

This manual describes the safety precautions for using the clamp-on probe and the clamp-on probe specifications. For details on its handling procedure, see the user's manual of the measuring instrument that the clamp-on probe will be used with.

5th Edition : December 2021 (YMI)  
All Rights Reserved, Copyright © 2015 Yokogawa Test & Measurement Corporation  
Printed in Japan

**YOKOGAWA** ◆

IM 96062-01EN  
5th Edition

## Checking the Package Contents

After receiving the product and opening the package, check the items described below. If the wrong items have been delivered, if items are missing, or if there is a problem with the appearance of the items, contact your nearest YOKOGAWA dealer. Check that the product that you have received is the same product that you ordered. For reference, the model name, suffix code, and specifications of the products are listed below.

### Clamp-on Probe

Model	Description
96062	Clamp-on Probe 100A
96064	Clamp-on Probe 500A

\* For products whose suffix code contains "Z," an exclusive manual may be included. Please read it along with the standard manual.

### Accessories

Name	Model or Component Number	Notes
Cable marker	-	6 pieces (3 x 2)
Manuals	IM 96062-01EN	This manual.
	IM 96062-92Z1	A manual for China.
	IM 00C01C01-01Z1	Safety manual (European languages)
	PIM 113-01Z2	Contact information of Yokogawa offices worldwide is provided.

\* The clamp-on probe comes with the these manuals. Please keep them in a safe place. The "-EN" in the manual number is the language code.

### Optional Accessories (Sold separately)

The following optional accessories are available for purchase separately. For information about ordering accessories, contact your nearest YOKOGAWA dealer.

Item	Model/Part No.	Min. Q'ty	Remark
Extension Code	98082	1	Only for 96062

## Safety Precautions

This product is designed to be used by a person with specialized knowledge. The general safety precautions described herein must be observed during all phases of operation. If the instrument is used in a manner not specified in this guide, the protection provided by the instrument may be impaired. YOKOGAWA assumes no liability for the customer's failure to comply with these requirements.

This manual is part of the product and contains important information. Store this manual in a safe place close to the instrument so that you can refer to it immediately. Keep this manual until you dispose of the instrument.

### The following symbols are used on this instrument.



Warning: handle with care. Refer to the user's manual or service manual. This symbol appears on dangerous locations on the instrument which require special instructions for proper handling or use. The same symbol appears in the corresponding place in the manual to identify those instructions.



Indicates a Instrument with double or reinforced insulation.



Indicates that this instrument can clamp on bare conductors.



Alternating current

### French



Avvertimento : À manipuler délicatement. Toujours se reporter aux manuels d'utilisation et d'entretien. Ce symbole a été apposé aux endroits dangereux de l'instrument pour lesquels des consignes spéciales d'utilisation ou de manipulation ont été émises. Le même symbole apparaît à l'endroit correspondant du manuel pour identifier les consignes qui s'y rapportent.



Équipement protégé par une double isolation ou une isolation renforcée.



Indicates that this instrument can clamp on bare conductors.



Courant alternatif

Failure to comply with the precautions below could lead to injury or death or damage to the instrument.

## WARNING

- This instrument is designed to measure the current. Do not use this instrument for anything other than as current measuring instrument.
- Do not use the instrument if there is a problem with its physical appearance.
- Never make measurement on a circuit in which the electrical potential exceeds AC 300 V in the measurement category III using 96062.
- Never make measurement on a circuit in which the electrical potential exceeds AC 600 V in the measurement category III using 96064.
- Do not operate the instrument in the presence of flammable gasses or vapors. Doing so is extremely dangerous.
- Do not make measurement when thunder rumbling. If the instrument is in use, stop the measurement immediately and remove the instrument from the measured object.
- Do not use the instrument if the instrument or your hands are wet. Otherwise, electrical shock accident may occur.
- The transformer jaws are made of metal and their tips are not completely insulated. Be especially careful about the possible shorting where the measured object has exposed metal parts.
- Always keep your fingers and hands behind the barrier on the instrument to avoid the possible shock hazard.
- Use insulated protective gears, such as insulated gloves, for your safety when using this instrument.

- Only qualified YOKOGAWA personnel may remove the covers and disassemble or alter the instrument.
- Do not install or use the instrument outdoors or in locations subject to rain or water.

## CAUTION

- Do not step on or pinch the cord to prevent the jacket of cord from being damaged.
- The output connector shall be removed or connected without clamping a conductor. Otherwise, it may cause a failure.
- Do not expose the instrument to direct sunlight, high temperatures, humidity or dew.
- Never give shocks, such as vibration or drop, which may damage the instrument.
- Use a damp cloth and detergent for cleaning the instrument. Do not use abrasives or solvents

### Operating Environment Limitations

This product is a Class A (for industrial environments) product. Operation of this product in a residential area may cause radio interference in which case the user will be required to correct the interference.

### French

## AVERTISSEMENT

- L'instrument est conçu pour mesurer l'intensité. Ne pas utiliser cet instrument à d'autres fins que celles de mesure de l'intensité.
- Ne pas utiliser l'instrument si son intégrité physique semble être compromise.
- Ne jamais effectuer de mesure de l'intensité sur un circuit dans lequel le potentiel électrique dépasse 300 V CA dans la catégorie de mesure III utilisant 96062.
- Ne jamais effectuer de mesure de l'intensité sur un circuit dans lequel le potentiel électrique dépasse 600 V CA dans la catégorie de mesure III utilisant 96064.
- Ne pas utiliser l'instrument en présence de gaz ou de vapeurs inflammables. Cela pourrait être extrêmement dangereux.
- Ne pas effectuer de mesure lorsque le tonnerre gronde. Si l'instrument est en cours d'utilisation, arrêter immédiatement la mesure et retirer l'instrument de l'objet mesuré.
- Ne pas utiliser l'instrument s'il est mouillé ou si vos mains sont mouillées. Sinon, un choc électrique peut se produire.
- Les mâchoires du transformateur sont composées de métal et leurs embouts ne sont pas totalement isolés. Il faut être particulièrement attentif à l'éventuelle réduction à laquelle l'objet mesuré a exposé les pièces métalliques.
- Les mains et les doigts doivent toujours rester derrière la barrière de l'instrument afin d'éviter un éventuel choc.
- Utiliser des équipements de protection isolés, tels que des gants isolés, pour votre sécurité lors de l'utilisation de cet instrument.
- Seul le personnel YOKOGAWA qualifié est habilité à retirer le capot et à démonter ou modifier l'instrument. Certains composants à l'intérieur de l'instrument sont à haute tension et par conséquent, représentent un danger.
- Do not install or use the instrument outdoors or in locations subject to rain or water.

## ATTENTION

- Ne pas marcher sur le cordon et ne pas le pincer afin d'éviter que la gaine du cordon ne soit endommagée.
- Le connecteur de sortie doit être retiré ou raccordé sans serrer un conducteur. Si cette condition n'est pas respectée, cela risque de générer une défaillance.
- Ne pas exposer l'instrument aux rayons directs du soleil, à des températures élevées, à l'humidité ou à la rosée.
- Ne jamais faire de chocs, tels que des vibrations ou des chutes, qui risqueraient d'endommager l'instrument.
- Utiliser un chiffon humide et du détergent pour nettoyer l'instrument. Ne pas utiliser de produits abrasifs ou de solvants.

### Limitations relatives à l'environnement opérationnel

Ce produit est un produit de classe A (pour environnements industriels). L'utilisation de ce produit dans une zone résidentielle peut entraîner une interférence radio que l'utilisateur sera tenu de rectifier.

## Conventions Used in This Manual

The notes and cautions in this manual are categorized using the following symbols.



Improper handling or use can lead to injury to the user or damage to the instrument. This symbol appears on the instrument to indicate that the user must refer to the user's manual for special instructions. The same symbol appears in the corresponding place in the user's manual to identify those instructions. In the manual, the symbol is used in conjunction with the word "WARNING" or "CAUTION."

### WARNING

Calls attention to actions or conditions that could cause serious or fatal injury to the user, and precautions that can be taken to prevent such occurrences.

### CAUTION

Describes precautions that should be observed to prevent minor or moderate injury, or damage to the instrument.

### Note

Calls attention to information that is important for proper operation of the instrument.



### French

Une manipulation ou une utilisation incorrectes risquent de blesser l'utilisateur ou d'endommager l'instrument. Ce symbole apparaît sur l'instrument pour indiquer à l'utilisateur qu'il doit se reporter au manuel de l'utilisateur afin d'y lire les instructions spécifiques correspondantes. Ce même symbole apparaît à la section correspondante du manuel de l'utilisateur pour signaler lesdites instructions. Dans le manuel de l'utilisateur, ce symbole est accompagné des termes AVERTISSEMENT et ATTENTION.

### AVERTISSEMENT

Attire l'attention sur des gestes ou des conditions susceptibles de provoquer des blessures graves (voire mortelles), et sur les précautions de sécurité pouvant prévenir de tels accidents.

### ATTENTION

Attire l'attention sur des gestes ou des conditions susceptibles de provoquer des blessures légères ou d'endommager l'instrument ou les données de l'utilisateur, et sur les précautions de sécurité susceptibles de prévenir de tels accidents.

## Waste Electrical and Electronic Equipment (WEEE)



(EU WEEE Directive valid only in the EEA\* and UK WEEE Regulation in the UK)  
 This product complies with the WEEE marking requirement. This marking indicates that you must not discard this electrical/electronic product in domestic household waste. When disposing of products in the EEA or UK, contact your local Yokogawa office in the EEA or UK respectively.  
 \* EEA: European Economic Area

## Authorized Representative in the EEA

Yokogawa Europe B. V. is Authorized Representative of Yokogawa Test & Measurement Corporation in the EEA for this Product. To contact Yokogawa Europe B. V., see the separate list of worldwide contacts, PIM 113-01Z2.

## Disposal

When disposing of this instrument, follow the laws and ordinances of the country or region where the product will be disposed of.

## Measurement Category:

To ensure safe operation of measuring instruments, IEC 61010 establishes safety standards for various electrical environments, categorized as O to .IV, and called measurement categories.

Measurement category O (Other)

Applies to measurement of circuits that are not directly connected to a main power source. This category applies to measurement of secondary electric circuits in equipment across a transformer.

Measurement category II

Applies to measurement of circuits, such as household electric appliances and portable electric tools, that are connected to low-voltage installations.

Measurement category III

Applies to measurement of facility circuits, such as distribution boards and circuit breakers.

Measurement category IV

Applies to measurement of power source circuits, such as entrance cables to buildings and cable systems, for low-voltage installations.

## Names of Parts

Transform Jaw Barrier Trigger Cable Output connector

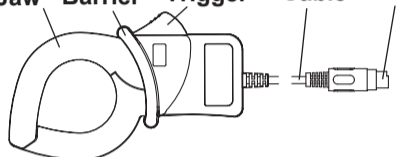

## Din Plug Pin Assignment

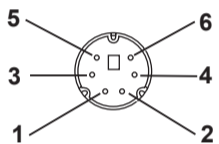

3: GND pin      5: Output signal pin  
 1, 2, 4 and 6: No use  
 \*This figure shows the pin assignment seeing the clamp sensor from output connector part. The figure of the pin assignment of connection terminal is symmetrical to above figure.

## Specifications

### 96062

Measureable conductor size	Max. $\phi$ 24 mm	
Measuring range	AC 0 to 100 Arms (141 A peak)	
Output voltage	AC 0 to 500 mVrms (5 mV/A)	
Accuracy (sine wave input)	Band width	$\pm 0.5\% \text{rdg} \pm 0.1 \text{ mV}$ (50/60 Hz)
	Phase	$\pm 1.0\% \text{rdg} \pm 0.2 \text{ mV}$ (40 Hz to 1 kHz)
Temperature & humidity range (guaranteed accuracy)	23 $\pm$ 5°C, 85%RH or less (no condensation)	
Rated voltage between circuit and ground	AC 300 Vrms Max.	
Operating temperature & humidity range	0 to 50°C, 85%RH or less (no condensation)	
Storage temperature & humidity range	-20 to 60°C, 90%RH or less (no condensation)	
Temperature coefficient	In the range of 0 to 50°C and the amount of change from 23°C is $\pm 0.5\% \text{rdg} \pm 0.1 \text{ mV}$ or less	
Maximum allowable input	AC 100 Arms continuous (50/60Hz)	
Influence of the conductor location	Within $\pm 0.5\% \text{rdg}$	
Influence of the external magnetic field	0.2 A equivalence or less (400 A/m, 50/60Hz)	
Output impedance	Approx. 11 $\Omega$	
Withstand voltage	AC 3.51 kVrms / 5 s Between jaw and case, case and output terminal, output terminal and jaw.	
Environmental condition	Altitude up to 2000 m, indoor use	
Recommended calibration period	1 year	
Dimension	60(W) $\times$ 100(H) $\times$ 26(D) mm (excluding projections)	
Cable length	Approx. 3m	
Output terminal	MINI DIN 6PIN	
Weight	Approx. 160g	
Accessory	Instruction manual, cable marker	
Safety standards	Compliant standards: EN 61010-1, EN 61010-2-032 Measurement category III (rated voltage between circuit and ground: 300Vrms) Pollution degree 2 <sup>1</sup>	
EMC	Compliant standards: EN 61326-1 Class A, EMC standards of Australia and New Zealand EN55011 Class A, Group 1 Korea Electromagnetic Conformity Standard ( 한국 전자파적합성기준 ) This product is a Class A (for industrial environment) product. Operation of this product in a residential area may cause radio interference in which case the user will be required to correct the interference. Immunity Influence (Performance degradation with self reset)	
Environmental standards <sup>2</sup>	EU RoHS Directive compliant	

- Pollution Degree applies to the degree of adhesion of a solid, liquid, or gas that deteriorates withstand voltage or surface resistivity. Pollution degree 2 applies to normal indoor atmospheres (with only non-conductive pollution).
- For conformity to environmental regulations and/or standards other than EU, contact your nearest YOKOGAWA office (PIM113-01Z2).

### 96064

Measureable conductor size	Max. $\phi$ 40 mm	
Measuring range	AC 0 to 500 Arms (707 A peak)	
Output voltage	AC 0 to 500 mVrms (1 mV/A)	
Accuracy (sine wave input)	Band width	$\pm 0.5\% \text{rdg} \pm 0.1 \text{ mV}$ (50/60 Hz)
	Phase	$\pm 1.0\% \text{rdg} \pm 0.4 \text{ mV}$ (40 Hz to 1 kHz)
Temperature & humidity range (guaranteed accuracy)	23 $\pm$ 5°C, 85%RH or less (no condensation)	
Rated voltage between circuit and ground	AC 600 Vrms Max.	
Operating temperature & humidity range	0 to 50°C, 85%RH or less (no condensation)	
Storage temperature & humidity range	-20 to 60°C, 90%RH or less (no condensation)	
Temperature coefficient	In the range of 0 to 50°C and the amount of change from 23°C is $\pm 0.5\% \text{rdg} \pm 0.1 \text{ mV}$ or less	
Maximum allowable input	AC 500 Arms continuous (50/60Hz)	
Influence of the conductor location	Within $\pm 0.5\% \text{rdg}$	
Influence of the external magnetic field	0.2 A equivalence or less (400 A/m, 50/60Hz)	
Output impedance	Approx. 2 $\Omega$	

Withstand voltage	AC 5.4 kVrms / 5 s Between jaw and case, case and output terminal, output terminal and jaw.
Environmental condition	Altitude up to 2000 m, indoor use
Recommended calibration period	1 year
Dimension	52(W) $\times$ 106(H) $\times$ 25(D) mm (excluding projections)
Cable length	Approx. 3m
Output terminal	MINI DIN 6PIN
Weight	Approx. 260g
Accessory	Instruction manual, cable marker
Safety standards	Compliant standards: EN 61010-1, EN 61010-2-032 Measurement category III (rated voltage between circuit and ground: 600Vrms) Pollution degree 2 <sup>1</sup>
EMC	Compliant standards: EN 61326-1 Class A EMC standards of Australia and New Zealand EN55011 Class A, Group 1 Korea Electromagnetic Conformity Standard ( 한국 전자파적합성기준 ) This product is a Class A (for industrial environment) product. Operation of this product in a residential area may cause radio interference in which case the user will be required to correct the interference. Immunity Influence (Performance degradation with self reset)
Environmental standards <sup>2</sup>	EU RoHS Directive compliant

- Pollution Degree applies to the degree of adhesion of a solid, liquid, or gas that deteriorates withstand voltage or surface resistivity. Pollution degree 2 applies to normal indoor atmospheres (with only non-conductive pollution).
- For conformity to environmental regulations and/or standards other than EU, contact your nearest YOKOGAWA office (PIM113-01Z2).

## External Dimensions

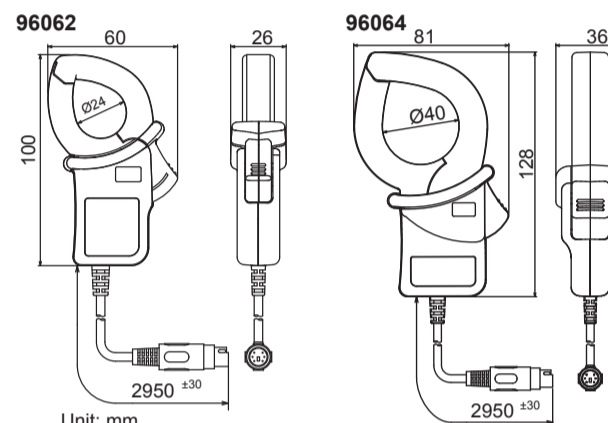

Unit: mm  
 Unless otherwise specified, tolerances are  $\pm 3\%$  (however, tolerances are  $\pm 0.3 \text{ mm}$  when below 10 mm).

## Measurement

### CAUTION

- Take sufficient care to avoid shock, vibration or excessive force when handling the instrument. Otherwise, precisely adjusted transformer jaws will be damaged.
- When transformer jaws do not fully close, never try to close them by force, but make them free to move and try again. If a foreign substance is stuck in the jaw tips, remove it.
- When making current measurements, keep the transformer jaws fully closed. Otherwise, accurate measurements cannot be taken.
- Maximum conductor size is as follows.  
 Model 96062 : 24 mm in diameter  
 Model 96064: 40 mm in diameter
- Hold the inserting part (except for the cable) and disconnect the Output connector from the measuring instrument so as not to cause a break in the cord.

## French

### ATTENTION

- Procéder avec suffisamment de soin pour éviter les chocs, les vibrations ou une force excessive lors de la manipulation de l'instrument. Si cette condition n'est pas respectée, les mâchoires du transformateur ajustées avec précision seront endommagées.
- Si les mâchoires du transformateur ne ferment pas totalement, ne jamais essayer de les fermer en forçant, mais les laisser libres et réessayer. Si une substance étrangère est bloquée dans les extrémités de la mâchoire, la retirer.
- "Lors de la prise de mesures d'intensité, maintenir les mâchoires du transformateur entièrement fermées. Si cette condition n'est pas respectée, il est impossible d'effectuer des mesures précises. La taille maximale du conducteur est la suivante.  
 Modèle 96062: 24 mm de diamètre  
 Modèle 96064: 40 mm de diamètre
- Maintenir la partie d'insertion (excepté pour le câble) et débrancher le connecteur de sortie de l'instrument de mesure afin de ne pas entraîner une rupture au niveau du cordon.

## Measurement procedures

- Connect the output connector to the Input terminal of the measuring instrument.
- Press the trigger to open the transformer jaws and clamp onto one conductor. The measured conductor shall be at the center of the jaws. When connecting a sensor with a power meter, match the arrow mark (power source to load), which is indicated on the transformer jaws, with the current flowing direction in order to synchronize the phases of measured current and output voltage.
- Ensure that the tips of transformer jaws are firmly closed.

