



**Short-tube
VA flow meter**

SGK 1-3



Assembly and operating Instructions

Short-tube VA flow meter SGK 1 - 3



Kirchner und Tochter

A. Kirchner & Tochter GmbH Dieselstraße 17 · D-47228 Duisburg
Fon: +49 2065 9609-0 · Fax: +49 2065 9609-22 Internet: www.kt-web.de · e-mail: info@kt-web.de
Version 2.3



Content

1. Foreword.....	3
2. Safety.....	3
2.1. Symbol and meaning.....	3
2.2. General safety directions and exemption from liability.....	3
2.3. Intended use.....	3
2.4. Special safety instructions concerning glass devices.....	4
2.5. Safety information for Operator and operating personnel.....	4
2.6. Regulations and guidelines.....	4
2.7. Notice as required by the hazardous materials directive.....	4
3. Transport and storage.....	4
4. Installation.....	5
4.1. Installation SGK.....	5
4.2. Parts (example: SGK, Model B).....	5
4.3. Preparations for assembly.....	6
4.4. SGK installation.....	6
5. Start-up.....	6
6. Readings in operation.....	7
7. Limit switches.....	7
7.1. MSK1/ MSK12/ MSKW.....	7
Connection of limit switches.....	8
Setting the limit switches.....	8
7.2. Limit switches RC10-14-N3/ RC15-14-N3.....	8
8. Maintenance.....	9
8.1. Cleaning the device.....	9
8.2. Replacement of measuring glass.....	9
9. Service.....	10
9.1. Disposal.....	10
10. Technical Data.....	11
Material.....	11
10.1. Dimensions.....	12
10.2. Design.....	13
10.3. Technical data of limit switches.....	13
MSK1, MSK12, MSKW.....	13
RC 10-14-N3/ RC 15-14-N3.....	14
Low-voltage directive.....	14



1. Foreword

These Installation and Operating Instructions are applicable to devices of Series SGK 1-3. Please follow all instructions and information given for installation, operation, inspection and maintenance. The Instructions form a component part of the device, and should be kept in an appropriate place accessible to the personnel in the vicinity of the location. Where various plant components are operated together, the operating instructions pertaining to the other devices should also be observed.

2. Safety

2.1. Symbol and meaning



Safety notice

This symbol is placed against all directions/information relating to occupational health and safety in these Installation and Operating Instructions, and draws attention to danger to life and limb. Such notices should be strictly observed.

2.2. General safety directions and exemption from liability

This document contains basic instructions for the installation, operation, inspection and maintenance of the flow monitor. Failure to comply with these instructions can lead to hazardous situations for Man and Beast and also to damage to property, for which Kirchner und Tochter disclaims all liability.

The Operator is required to rule out potentially hazardous situations through voltage and released media energy.

2.3. Intended use

The Series SGK 1-3 device is a short tube VA flow meter designed for liquids and gases, and for installation in switch panels.

Direction of flow is upwards, from bottom to top. Inlet and outlet are located in the horizontal, but optionally may also be in the vertical (see Model Types, Section 10.3). Installation should be carried out solely in accordance with these Instructions. The limit values pertaining to the device are given in Section 10 and should not be exceeded. Modifications or other alterations to the flow meter may only be carried out by Kirchner und Tochter. Details of the process product and the operating conditions are marked on the measuring glass.



2.4. Special safety instructions concerning glass devices



For safety reasons, we recommend fitting a protective shield in front of the measuring tube when starting up flow meters fitted with glass measuring tubes. The devices should not be operated where there is a risk of pressure surges (water hammer)!

To avoid glass breakage, all fitting work between measuring glass and heads inside the glass should be carried out by twisting and simultaneously pressing after having wetted the packing rings/gaskets.

2.5. Safety information for Operator and operating personnel

Authorized installation, operating, inspection and maintenance personnel should be suitably qualified for the jobs assigned to them, and should receive appropriate training and instruction.

2.6. Regulations and guidelines

In addition to the directions given in these Installation and Operating Instructions, observe the regulations, guidelines and standards, such as DIN EN, and, for specific applications, the codes of practice issued by DVGW (gas and water) and VdS (underwriters), or the equivalent national codes, and applicable national accident prevention regulations.

2.7. Notice as required by the hazardous materials directive

In accordance with the law concerning handling of waste (critical waste) and the hazardous materials directive (general duty to protect), we would point out that all flow meters returned to Kirchner und Tochter for repair are required to be free from any and all hazardous substances (alkaline solutions, acids, solvents, etc.).



Make sure that devices are thoroughly rinsed out to neutralize hazardous substances.

3. Transport and storage

Always use the original packing for transport, handling and storage. Protect the device against rough handling, impact, jolts, etc.



4. Installation

Variable area flow meters are only suitable for vertical installation, where the direction of flow is from bottom to top. For all other installation situations, appropriate pipe bends need to be fitted in the existing pipeline in order to ensure vertical flow through the device from below.

Before installing, remove all protective caps, transport locks and any foreign bodies found. Pay regard to the correct spacing and exact alignment of the pipes at the point of installation. For Type SGK: before installation, both free ends of the pipe additionally need to be provided with pipe fittings.

4.1. Installation SGK

4.2. Parts (example: SGK, Model B)

- 1 Head (here: for vertically outflowing medium, device model B)
- 2 Batching valve (here: at bottom, Model B)
- 3 Glass cone
- 4 Channel section for fastening the heads or batching valve, with glass cone, Item 3, fitted
- 5 G1/4" or G1/2" nut for fastening, for horizontally in- and outflowing medium
- 6 Nut M5 or M8 for fastening the heads, for vertically in- and outflowing medium
- 7 O-ring in Item 1 and 2 (not shown)¹⁾
- 8 Flat gaskets in Items 1 and 2 (not shown)¹⁾

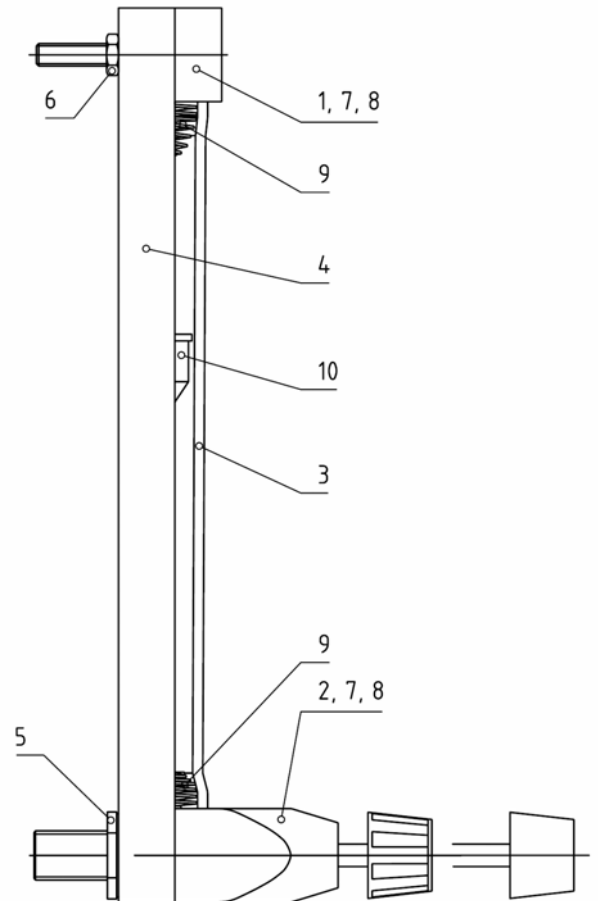

¹⁾ The glass cone is sealed off internally at either end by an O-ring and additionally protected against breakage by flat gaskets inserted in Items 1 and 2.



4.3. Preparations for assembly

The SGK flow meter consists of a channel section in which the tapered measuring glass is firmly held in place by the two connecting heads with or without integrated batching valve.

Preparatory work at the point of installation:

1. Shut off and secure the pipe system in accordance with regulations, and drain the pipeline.
2. Any control equipment, particularly in the case of gaseous media, should be located downstream of the measuring device.
3. If necessary, support the pipeline to prevent vibration from being transmitted to the measuring device.
4. Clean the pipelines leading to the device by blowing or flushing them out before connecting up the device.
5. Before installing, fit the two free ends of the pipe with appropriate connecting threaded joints (see Section 10.1). The heads with vertical pipe connection on the front of the switch panel are provided with internal threads.

Installation of the SGK requires a hole pattern on the switch panel in accordance with the Table, Section 10.2, that matches the selected model (to take up thread G and/or M on Items 5 and 6).

4.4. SGK installation

1. Remove the nuts (Items 5 and 6) on the back of the channel section, and position the device on the switch panel in the holes provided.
2. Then fasten the device to the switch panel by fitting the nuts on the back of the channel.
3. Connect the ends of the pipe at the installation point to the SGK device using appropriate sealing material.

5. Start-up

The device must be properly installed before it is started up.

1. Check all device connections.
2. To set the flow: pressurize the pipelines by slowly opening the shut-off valves (risk of glass breakage!). On liquid service: carefully evacuate the pipeline.
3. Check the leak-tightness of all components and, if necessary, tighten down threaded joints or screw connections.



6. Readings in operation

The flow value is read off from the scale on the glass cone at the top edge of the float. The measured-value readings are only correct when the operating condition at the measuring point (flowing medium, operating pressure and temperature) corresponds to the values marked on the measuring glass. If operating conditions should differ, the measured value must be corrected with the aid of the general float equation, which you will find in our technical documents.

You can also do the recalculation with the help of our conversion program given on our home page: www.kt-web.de, Section "Physical Basics".

7. Limit switches

7.1. MSK1/ MSK12/ MSKW

The limit switches consist of a limit switch (reed switch) that is switched over by the magnet integrated in the float. The limit switch is guided in a guide slot in the protective case and can be adjusted over the full measuring range. The reed switches have a bistable characteristic.

Uncontrolled current and voltage peaks can occur in the case of inductive or capacitive loads, e.g. from contactors or solenoid valves. Such peaks will also occur, depending on cable geometry, where cables exceed a certain length. We therefore recommend using an MSR contact protection relay, which is additionally available. This will increase the contact rating and prevent occurrence of inductive and capacitive peaks, thus ensuring long service life of the contacts.

Electrical data and limit values are specified in Section 10.4.



Connection of limit switches



Electrical connection of the device must be carried out in conformity with the relevant VDE regulations (or equivalent national standards) and in accordance with the regulations issued by the local power supply utility.

Disconnect the plant from supply before connecting the limit switch.

Provide a protective circuit for the switches in keeping with their capacity.

Connect line-side fuse elements matched to consumption.

Connect the cable using the supplied right-angle plug. Assigned are terminals 1 and 3. Earth and terminal 2 is not assigned. The circuit diagram for limit switches is shown in the Technical Data, Section 10.4 on page 13.

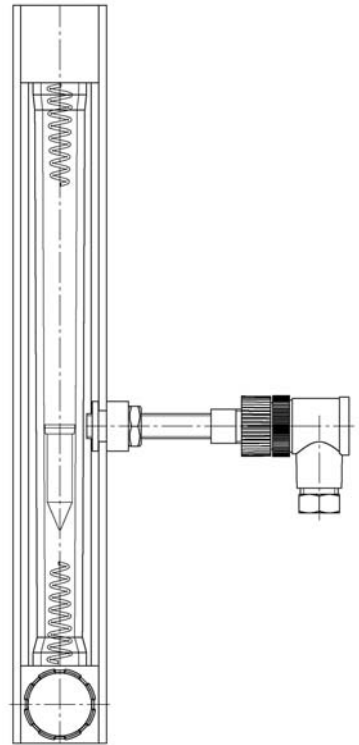

Setting the limit switches

Fasten the contact with right-angle plug on the channel section. The operating point is infinitely adjustable by sliding the contact along the channel. The contact is fastened by way of an M4 grub screw on the contact holder.

7.2. Limit switches RC10-14-N3/ RC15-14-N3

The limit switches, designed in the form of a ring, are located on the glass cone and can be shifted along the cone and locked in the required position.

Be aware of the safety information given in Section 7.

Cable connection is effected at the contact cable. The circuit diagram for the limit switches is shown under Technical Data, Section 10.4 on page 14.



8. Maintenance

To avoid risk of glass breakage, all assembly/dismantling procedures between measuring glass and heads in the glass should be carried out by simultaneous twisting and pressing the heads after previously having moistened the sealing rings. Close off and secure the pipe system according to regulations and drain the pipes before dismantling the device.

8.1. Cleaning the device

The device is maintenance-free. Should the glass cone become fouled, the device can be cleaned as follows:

1. Detach the device from the pipe ends at the installation location.
2. Detach the nuts, Items 6 and 5.
3. Remove the device from the switch panel.
4. Detach the channel section, Item 4, from the heads, Items 1 and 2, with the glass Item 3.
5. Remove by simultaneously twisting the heads, Items 1 and 2, and pulling them out of the glass cone.
6. Remove the float stop (helical springs), Item 9, from the glass cone. To avoid glass breakage and scratches, use pliers to simultaneously twist and pull the springs in the coiling direction.
7. Then proceed to clean the glass cone. Do not use aggressive cleaning agents (wire brush, scouring agent, alkaline solutions, acids, etc.).
8. When reinstalling, make sure the O-rings, Item 7, are undamaged. Replace if necessary.
9. Assembling the device and installing it in the switch panel are carried out in reverse order.

8.2. Replacement of measuring glass

1. To dismantle the device, proceed as described under Point 8.1.
The new measuring glass contains the appropriate float including the stops at the ends of the cone.
2. Replace the old cone with stops and float and re-install the device on the switch panel.



9. Service

All devices with defects or deficiencies should be sent direct to our repair department. To enable our customer service facility to deal with complaints and repairs as quickly as possible, you are kindly requested to coordinate the return of devices with our sales department, Tel. +49 2065-96090.

9.1. Disposal

Please help to protect our environment, and dispose of workpieces in conformity with current regulations or use them for some other purpose.



10. Technical Data

Device body

Connection	External/internal thread to DIN ISO 228 T1, optionally hose connector
Construction	A – Do, see table on design
Temp. resistance	80°C with NBR gaskets, 100°C with Viton gaskets
Working pressure	max. 10 bar, no pressure surges

Measuring cone

Scale	stove-enamelled scale
Scale length SGK 1-2	approx. 150 mm
Scale length SGK 3	approx. 220 mm
Accuracy class	1,6 to VDI/VDE 3513
Calibration	customer-specific calibration

10.1. Material

Strap, channel	Aluminium, black anodized
Connections	Standard: aluminium anodized or PVC, optionally 1.4571, PVDF; others on request
Gaskets	Standard NBR, optionally EPDM, Viton, others on request
Measuring cone	borosilicate glass
Float	Aluminium, PVC, 1.4571, optionally PP
Spindle	1.4571



10.2. Dimensions

	G in inch	Design	H	h	M	L	B	D	C
SGK 1	1/4	A1, A2, A0	247	220	-	ca. 22,5	27,5	30	85 [A1, A2 only]
SGK 2	1/4	A1, A2, A0	238	213	-	ca. 22,5	27,5	30	85 [A1, A2 only]
	1/4	B1, B0, C1, C0	242	211	M5	ca. 22,5	27,5	30	85 [B, C only]
	1/4i	DO	246	209	M5	ca. 22,5	27,5	30	-
SGK 3	1/2	A1, A2, A0	363	323	-	ca. 27	45	50	135 [A1, A2 only]
	1/2	B1, B0, C1, C0	363	320	M8	ca. 27	45	50	135 [B, C only]
	1/2i	DO	363	317	M8	ca. 27	45	50	-

all dimensions in mm

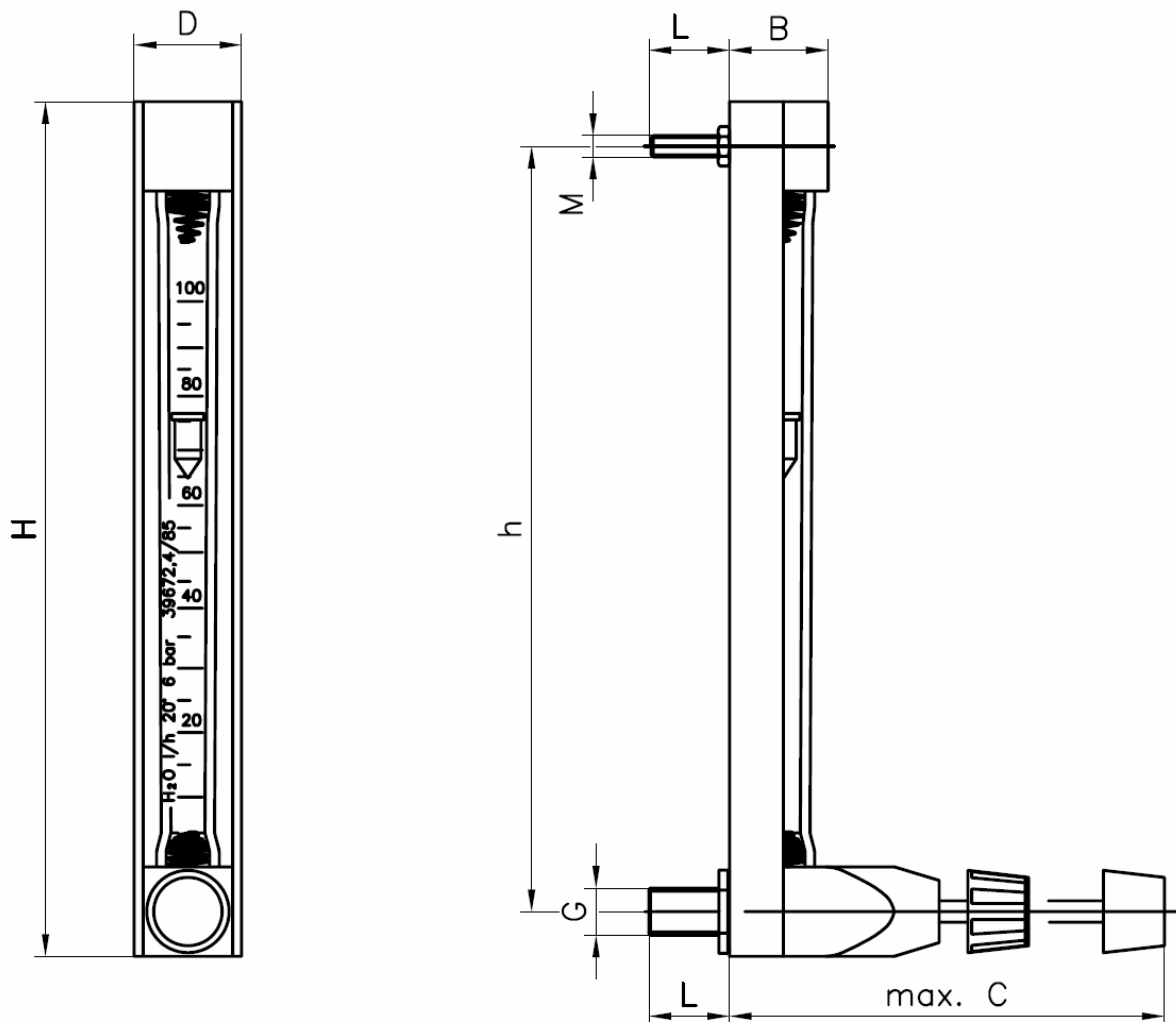



10.3. Design

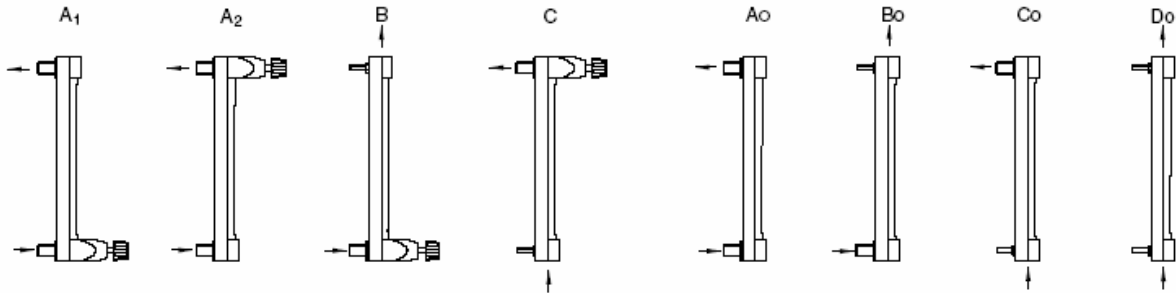

10.4. Technical data of limit switches

MSK1, MSK12, MSKW

Design	MSK1	MSK12
Voltage switched	50VAC/75VDC	50VAC/75VDC
Current switched	0,5A	0,5A
Contact rating	10W/VA	10W/VA
Dielectric strength	230VAC/400VDC	230VAC/400VDC
Temperature range	-20 bis +90°C	-20 bis +90°C
Switching function	normally closed contact	normally open contact
Connection		
Design	MSKW	
Voltage switched	50VAC/75VDC	
Current switched	0,5A	
Contact rating	5W/VA	
Dielectric strength	110VAC/200VDC	
Temperature range	-20 bis +90°C	
Switching function	change over contact	
Connection		

¹⁾ The deciding factor is the thermal endurance of the flow meter!
Connection via right angle plug M12x1



RC 10-14-N3/ RC 15-14-N3

	RC10-14-N3	RC15-14-N3
Rated voltage	8 V DC	8 V DC
Current consumption	1 mA/3 mA	1 mA/3 mA
Sweep rate	≤ 10 m/s	≤ 10 m/s
Self-inductance	≤ 120 μ H	≤ 70 μ H
Self-capacitance	≤ 90 nF	≤ 90 nF
Temperature range	-20 to +70 °C	-20 to +70 °C
Switching function	NAMUR bistable	NAMUR bistable
Connection		

Connection by way of a PVC cable (2 metres)

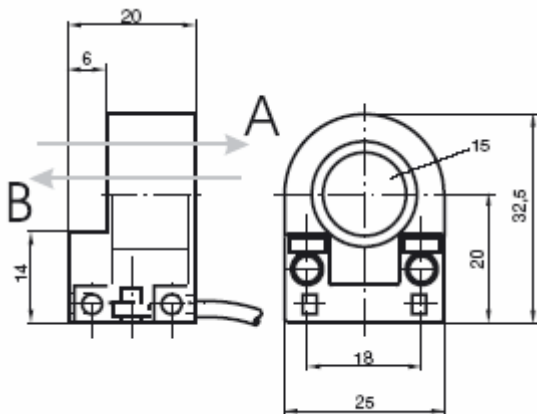

Low-voltage directive

Above 50 V AC/75 V DC, contacts are subject to the EU Low-Voltage Directive. The user is required to verify their use accordingly.



The Kirchner equipment has been tested in compliance with the applicable CE-regulations of the European Community. The respective declaration of conformity is available on request.

The KIRCHNER QM-System is certified in accordance with DIN-EN-ISO 9001:2008. The quality is systematically adapted to the continuously increasing demands. An appropriate declaration of conformity will be provided on request.