

# DIGITAL MULTIMETER 3435A

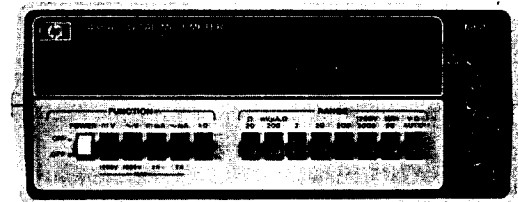
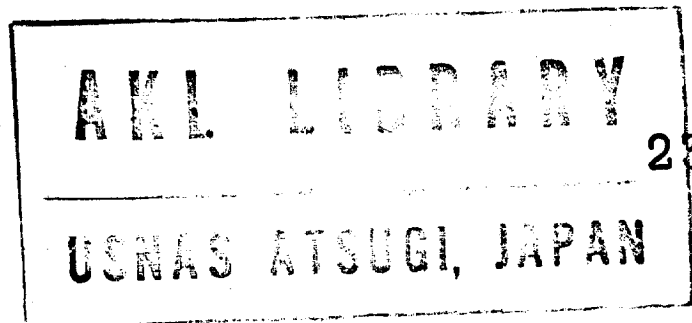

HEWLETT  PACKARD

## **COPYRIGHT AND DISCLAIMER NOTICE**

Copyright – Agilent Technologies, Inc. Reproduced with the permission of Agilent Technologies Inc. Agilent Technologies, Inc. makes no warranty of any kind with regard to this material including, but not limited to, the implied warranties of merchantability and fitness for a particular purpose. Agilent Technologies, Inc. is not liable for errors contained herein or for incidental or consequential damages in connection with the furnishing, performance, or use of this material or data.

# hp MANUAL CHANGES

MODEL 3435A

DIGITAL MULTIMETER

Manual Part No. 03435-90001

■ New or Revised Item

**CHANGE NO. 1 (PC 09-13868)** applies to serial numbers 1606A01051 and above.

Page 6-6, Table 6-4. Add "Table 6-5 Option 002 Miscellaneous Parts" to your manual after Table 6-4 as shown below.

Table 6-5. Option 002 Miscellaneous Parts.

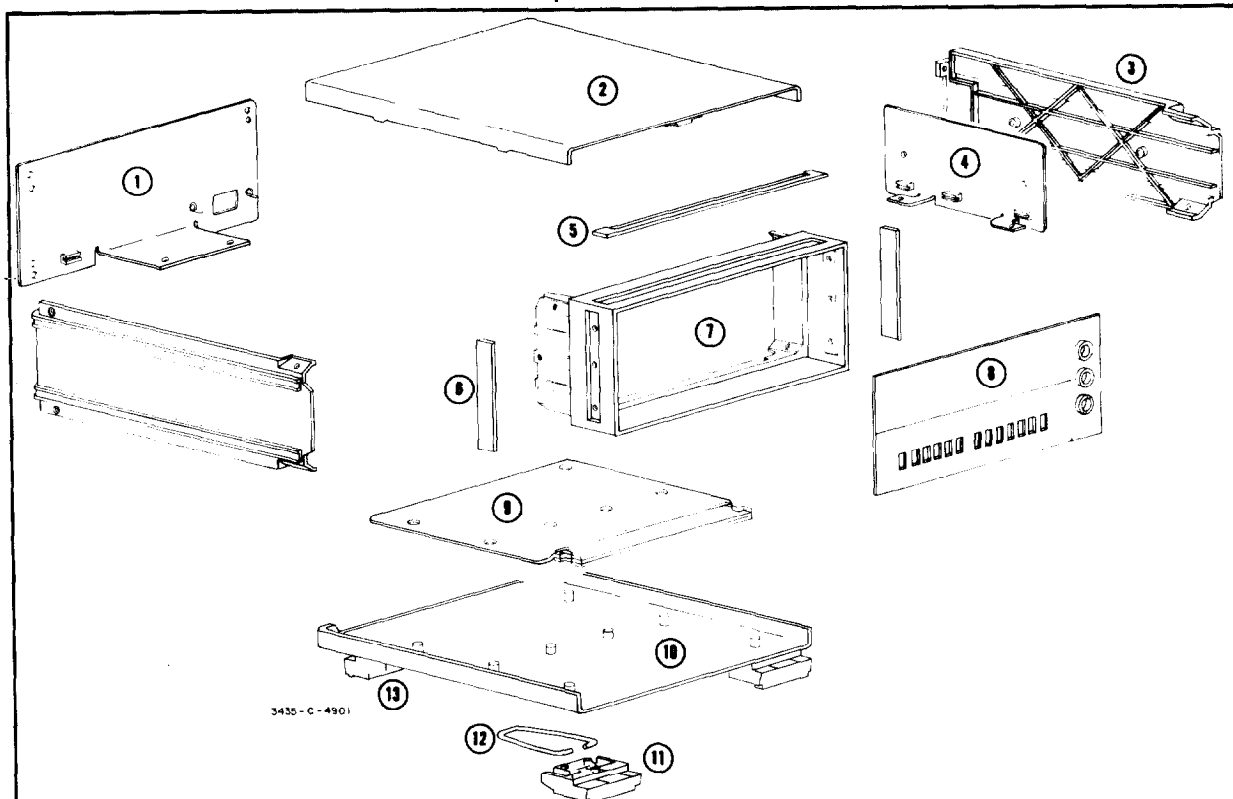

3435-C-4901

**Fastening Hardware**

| Index No. | -hp- Part No. | Description   | TQ | Description                | -hp- Part No. | TQ |
|-----------|---------------|---------------|----|----------------------------|---------------|----|
| 1         | 03435-00202   | Rear Panel    | 1  | Side shield screws         | 2360-0113     | 8  |
| 2         | 5040-7208     | Top Cover     | 1  | Grounding screws           | 2680-0128     | 1  |
| 3         | 5040-8210     | Side Cover    | 2  | Grounding lug              | 0360-0053     | 1  |
| 4         | 03435-00604   | Side Shield   | 2  | Back Panel Screws          | 2360-0199     | 6  |
| 5         | 5040-7203     | Top Trim      | 1  | Front Panel Screws         | 2510-0099     | 4  |
| 6         | 5001-0438     | Side Trim     | 2  | Transformer Screws         | 2360-0121     | 2  |
| 7         | 5020-8813     | Front Frame   | 1  | Center Screw (A1 PC Board) | 2360-0119     | 1  |
| 8         | 03435-00201   | Front Panel   | 1  | Bottom Shield Screws       | 2360-0113     | 8  |
| 9         | 03435-00603   | Bottom Shield | 1  | Top Cover Screws           | 2360-0199     | 6  |
| 10        | 5040-7209     | Bottom Cover  | 1  | Bottom Cover Screws        | 2360-0330     | 2  |
| 11        | 5040-7201     | Front Foot    | 2  | Square Plastic Washer      | 5040-7853     | 4  |
| 12        | 1460-1345     | Tilt Stand    | 2  |                            |               |    |
| 13        | 5040-7222     | Rear Foot     | 2  |                            |               |    |

18 November 1977

Supplement A for 03435-90001

## Errata.

Page 6-3, Table 6-3. Change the part number of A1J1 to 1251-4743.

Page 6-6, Table 6-4. Delete number ⑪, NON-skid pad.

**CHANGE NO. 2 applies to serial numbers 1706A02851 and above.**

Page 6-6, Table 6-4. Add label-caution, 7120-3530 to the Miscellaneous Parts list.

Page 6-3, Table 6-3. Change the part number and description of A1CR403, 404, 405 and 406 to 1901-0029, Diodes .75A 600 V.

**CHANGE NO. 3 applies to serial number 1606A03616 and above.**

Page 6-3/6-4, Table 6-3. Change the part number and description of the following parts as listed in Table CS-1.

Table CS-1 P/O Table 6-3.

|             |             |                    |
|-------------|-------------|--------------------|
| A1C109      | 0121-0451   | C-V 1.7/11 PF      |
| A1C112, 113 | 0180-0309   | C-F 4.7 UF 35 V    |
| A1R124      | 0698-4479   | R-F 14 K .01 1/8 W |
| A1R127, 128 | 0757-0449   | R-F 20 K .01 1/8 W |
| A1R129, 130 | 0757-0283   | R-F 2 K .01 1/8 W  |
| A1R123      | 2100-3211   | R-V 1 K .01        |
| A1          | 03435-66521 |                    |
| A2          | 03435-66522 |                    |

Page 6-6, Table 6-4. Add test lead set, 8120-2521 to the Miscellaneous Parts list. Change ⑩ to 03435-66521.

Page 7-11/7-12, Figure 7-6. Change the values of the following reference designators as shown in the Table CS-2.

Table CS-2.

|           |          |              |
|-----------|----------|--------------|
| C109      | 1.3-5 PF | <del>*</del> |
| C112, 113 | 4.7      |              |
| R124      | 14 K     |              |
| R127, 128 | 20 K     |              |
| R129, 130 | 1 K      |              |
| R123      | 1 K      |              |

Page 5-9/5-10, 7-8, 7-11/7-12, 7-13, 7-15/7-16. Change the -hp- part numbers for the A1 and A2 P.C. boards to 03435-66521 and 03435-66522 respectively.



**OPERATING AND SERVICE MANUAL**  
**MODEL 3435A**  
**DIGITAL MULTIMETER**

Serial Numbers 1606A00101 and Greater

**IMPORTANT NOTICE**

Any changes made in instruments manufactured after this printing will be found in a "Manual Changes" supplement supplied with this manual. Be sure to examine this supplement, if one exists for this manual, for any changes which apply to your instrument and record these changes in the manual.

**WARNING**

*To help minimize the possibility of electrical fire or shock hazards, do not expose this instrument to rain or excess moisture.*

Manual Part No. 03435-90001

Microfiche Part No. 03435-90051

ALL LIBRARY

23 JAN 1978

Copyright Hewlett-Packard Company 1976  
P.O. Box 301, Loveland, Colorado, 80537 U.S.A.

USIAS ATSUGI, JAPAN

Printed: July 1976



### **CERTIFICATION**

*Hewlett-Packard Company certifies that this instrument met its published specifications at the time of shipment from the factory. Hewlett-Packard Company further certifies that its calibration measurements are traceable to the United States National Bureau of Standards, to the extent allowed by the Bureau's calibration facility, and to the calibration facilities of other International Standards Organization members.*

### **WARRANTY AND ASSISTANCE**

This Hewlett-Packard product is warranted against defects in materials and workmanship for a period of one year from the date of shipment, except that in the case of certain components, if any, listed in Section I of this operating manual, the warranty shall be for the specified period. Hewlett-Packard will, at its option, repair or replace products which prove to be defective during the warranty period provided they are returned to Hewlett-Packard, and provided the proper preventive maintenance procedures as listed in this manual are followed. Repairs necessitated by misuse of the product are not covered by this warranty. **NO OTHER WARRANTIES ARE EXPRESSED OR IMPLIED, INCLUDING BUT NOT LIMITED TO THE IMPLIED WARRANTIES OF MERCHANTABILITY AND FITNESS FOR A PARTICULAR PURPOSE. HEWLETT-PACKARD IS NOT LIABLE FOR CONSEQUENTIAL DAMAGES.**

If this product is sold as part of a Hewlett-Packard integrated instrument system, the above warranty shall not be applicable, and this product shall be covered only by the system warranty.

Service contracts or customer assistance agreements are available for Hewlett-Packard products.

For any assistance, contact your nearest Hewlett-Packard Sales and Service Office. Addresses are provided at the back of this manual.

**TABLE OF CONTENTS**

| Section   | Page |
|---|------|
| I. GENERAL INFORMATION . . . . .                    | 1-1  |
| 1-1. Introduction . . . . .                         | 1-1  |
| 1-3. Description . . . . .                          | 1-1  |
| 1-5. Specifications . . . . .                       | 1-1  |
| 1-7. Instrument and Manual Identification . . . . . | 1-1  |
| 1-9. Options . . . . .                              | 1-3  |
| 1-12. Accessories . . . . .                         | 1-3  |
| 1-14. Safety Considerations . . . . .               | 1-4  |

| Section                                     | Page |
|---|------|
| II. INSTALLATION . . . . .                  | 2-1  |
| 2-1. Introduction . . . . .                 | 2-1  |
| 2-3. Initial Inspection . . . . .           | 2-1  |
| 2-5. Power Requirements . . . . .           | 2-1  |
| 2-7. Environmental Requirements . . . . .   | 2-1  |
| 2-9. Repackaging for Shipment . . . . .     | 2-1  |
| 2-13. Power Cords and Receptacles . . . . . | 2-1  |

| Section  | Page    |
|--|---------|
| III. OPERATING INSTRUCTIONS . . . . .                              | 3-1     |
| 3-1. INTRODUCTION . . . . .  | 3-1     |
| 3-3. AC Operation . . . . .  | 3-1     |
| 3-5. Battery Operation . . . . .                                   | 3-1     |
| 3-10. Overload/Overrange/Improper<br>Function Indication . . . . . | 3-1     |
| 3-13. Auto . . . . .   | 3-2     |
| 3-16. Input Terminals . . . . .                                    | 3-2     |
| 3-20. AC Voltage Measurements . . . . .                            | 3-2     |
| 3-22. DC Voltage Measurements . . . . .                            | 3-2     |
| 3-24. AC Current Measurements . . . . .                            | 3-3     |
| 3-26. DC Current Measurement . . . . .                             | 3-3     |
| 3-28. Resistance Measurements . . . . .                            | 3-4     |
| 3-30. Handle/Bail . . . . .  | 3-4     |
| 3-32. Option Decal . . . . .                                       | 3-4     |
| 3-34. Information Decal . . . . .                                  | 3-4     |
| 3-36. Amps Input Fuse Replacement . . . . .                        | 3-4     |
| 3-38. Multimeter Cleaning . . . . .                                | 3-5/3-6 |

| Section   | Page    |
|---|---------|
| IV. THEORY OF OPERATION . . . . .                                   | 4-1/4-2 |
| 4-1. Introduction . . . . .   | 4-1/4-2 |
| 4-3. Simplified Block Diagram Description<br>(Figure 4-1) . . . . . | 4-1/4-2 |

| Section                                | Page |
|--|------|
| V. MAINTENANCE . . . . .               | 5-1  |
| 5-1. Introduction . . . . .            | 5-1  |
| 5-3. Test Equipment Required . . . . . | 5-1  |
| 5-5. Performance Tests . . . . .       | 5-1  |

| Section  | Page |
|--|------|
| V. MAINTENANCE (Cont'd) . . . . .                              | 5-1  |
| 5-6. AC Voltage Accuracy Test . . . . .                        | 5-1  |
| 5-8. DC Voltmeter Accuracy Test . . . . .                      | 5-1  |
| 5-10. AC Ammeter Accuracy Test . . . . .                       | 5-2  |
| 5-11. DC Ammeter Accuracy Test . . . . .                       | 5-2  |
| 5-13. Ohms Accuracy Test . . . . .                             | 5-3  |
| 5-15. AC Normal-Mode Rejection Test . . . . .                  | 5-3  |
| 5-17. Effective Common-Mode<br>Rejection Test . . . . .        | 5-4  |
| 5-19. Adjustment Procedure . . . . .                           | 5-6  |
| 5-21. ① + 7 V Power Supply<br>Adjustment (R417) . . . . .      | 5-6  |
| 5-22. Battery Charge Voltage<br>Adjustment (R818) . . . . .    | 5-6  |
| 5-23. ② Clock Frequency<br>Adjustment (R9) . . . . .           | 5-6  |
| 5-24. ③ AC Zero Adjustment (R203) . . . . .                    | 5-6  |
| 5-25. ④ 29 Ohms Zero<br>Adjustment (R111) . . . . .            | 5-6  |
| 5-26. ⑤ DC Gain Adjustment (R403) . . . . .                    | 5-6  |
| 5-27. ⑥ Ohms Gain Adjustment (R119) . . . . .                  | 5-6  |
| 5-28. ⑦ AC Gain Adjustment (R123) . . . . .                    | 5-6  |
| 5-29. ⑧ 20 V Range, 20 kHz<br>Adjustment (R102) . . . . .      | 5-6  |
| 5-30. ⑨ 2 V Range, 20 kHz<br>Adjustment (R110) . . . . .       | 5-7  |
| 5-31. Power Requirement Modification<br>Instructions . . . . . | 5-7  |

| Section                             | Page |
|-------------------------------------|------|
| VI. REPLACEABLE PARTS . . . . .     | 6-1  |
| 6-1. Introduction . . . . .         | 6-1  |
| 6-4. Ordering Information . . . . . | 6-1  |
| 6-6. Non-Listed Parts . . . . .     | 6-1  |
| 6-8. Parts Changes . . . . .        | 6-1  |
| 6-10. Proprietary Parts . . . . .   | 6-1  |

| Section  | Page    |
|--|---------|
| VII. CIRCUIT DIAGRAMS . . . . .                        | 7-1     |
| 7-1. Introduction . . . . .                            | 7-1     |
| 7-3. Schematic Diagrams . . . . .                      | 7-1     |
| 7-5. Troubleshooting . . . . .                         | 7-1     |
| 7-7. Preliminary Troubleshooting . . . . .             | 7-1     |
| 7-13. Disassembly Procedure . . . . .                  | 7-2     |
| 7-15. General Troubleshooting<br>Information . . . . . | 7-3     |
| 7-21. Analog Troubleshooting . . . . .                 | 7-5/7-6 |
| 7-27. Digital Troubleshooting . . . . .                | 7-5/7-6 |

**APPENDIX**

Sales and Service Office

## LIST OF TABLES

| Table   | Page | Table                                      | Page |
|---|------|--|------|
| 1-1. Specifications . . . . .   | 1-1  | 5-6. DC Ammeter Accuracy Test . . . . .    | 5-4  |
| 1-2. General Information . . . . .  | 1-3  | 5-7. Ohms Accuracy Test . . . . .          | 5-4  |
| 1-3. Options . . . . .  | 1-3  | 6-1. Standard Abbreviations . . . . .      | 6-1  |
| 1-4. Accessories . . . . .  | 1-3  | 6-2. Code List of Manufacturers . . . . .  | 6-2  |
| 3-1. Improper Switch Combinations . . . . .                               | 3-1  | 6-3. Replaceable Parts . . . . .           | 6-3  |
| 5-1. Test Equipment Required . . . . .                                    | 5-0  | 6-4. Miscellaneous Parts . . . . .         | 6-6  |
| 5-2. AC Voltage Accuracy Test . . . . .                                   | 5-1  | 7-1. Simplified Performance Test . . . . . | 7-2  |
| 5-3. DC Voltage Accuracy Test . . . . .                                   | 5-2  | 7-2. AC Gain . . . . .                     | 7-2  |
| 5-4. AC Ammeter Accuracy Test, 200 $\mu$ A<br>thru 20 mA Ranges . . . . . | 5-3  | 7-3. DC Gain . . . . .                     | 7-2  |
| 5-5. AC Ammeter Accuracy Test, 200 mA<br>and 2000 mA Ranges . . . . .     | 5-3  | 7-4. Test Jumpers . . . . .                | 7-3  |
|   |      | 7-5. Test Pads . . . . .                   | 7-3  |
|   |      | 7-6. Digital Troubleshooting . . . . .     | 7-4  |

## LIST OF ILLUSTRATIONS

| Figure  | Page    | Figure   | Page      |
|---|---------|--|-----------|
| 2-1. Power Receptacles . . . . .  | 2-1     | 5-5. Ohms Accuracy Test . . . . .  | 5-4       |
| 3-1. Description on Controls and Connectors . . . . .                   | 3-0     | 5-6. AC Normal-Mode Rejection Test . . . . .   | 5-4       |
| 3-2. Battery Voltage Access Hole . . . . .                              | 3-1     | 5-7. Effective Common-Mode Rejection Test . . . . .  | 5-5       |
| 3-3. Overload Indication . . . . .                                      | 3-1     | 5-8. DC Gain Adjustment . . . . .  | 5-6       |
| 3-4. Multimeter Autoranging . . . . .                                   | 3-2     | 5-9. AC Gain Adjustment . . . . .  | 5-7/5-8   |
| 3-5. AC Voltage Measurement . . . . .                                   | 3-2     | 5-10. Line Voltage Configurations . . . . .  | 5-7/5-8   |
| 3-6. DC Voltage Measurements . . . . .                                  | 3-3     | 5-11. Adjustment Locator . . . . .   | 5-9/5-10  |
| 3-7. AC Current Measurements . . . . .                                  | 3-3     | 7-1. Functional Block Diagram . . . . .  | 7-3       |
| 3-8. DC Current Measurements . . . . .                                  | 3-4     | 7-2. Battery Charger Block Diagram . . . . .   | 7-4       |
| 3-9. Resistance Measurement . . . . .                                   | 3-4     | 7-3. Charge Current/Voltage . . . . .  | 7-5/7-6   |
| 3-10. Handle/Bail Positioning . . . . .                                 | 3-5/3-6 | 7-4. Simplified Analog Schematic . . . . .   | 7-7       |
| 3-11. Option Decal . . . . .  | 3-5/3-6 | 7-5. 3435A Input Switching, Input Amplifier and<br>Ohms Current Source Schematics . . . . .              | 7-9/7-10  |
| 3-12. Information Decal . . . . .                                       | 3-5/3-6 | 7-6. 3435A Post Amplifier, AC to DC Converter<br>and Analog to Digital Converter<br>Schematics . . . . . | 7-11/7-12 |
| 4-1. Simplified Block Diagram . . . . .                                 | 4-1/4-2 | 7-7. Display Schematic . . . . .   | 7-13      |
| 5-1. AC Voltage Accuracy Test . . . . .                                 | 5-1     | 7-8. Power Supply and Battery Charger<br>Schematics . . . . .  | 7-15/7-16 |
| 5-2. DC Voltmeter Accuracy Test . . . . .                               | 5-2     |  |           |
| 5-3. AC Ammeter Accuracy Test 200 $\mu$ A<br>thru 20 mA Range . . . . . | 5-2     |  |           |
| 5-4. DC Ammeter Accuracy Test . . . . .                                 | 5-3     |  |           |

## SECTION I GENERAL INFORMATION

### 1-1. INTRODUCTION.

1-2. This section contains general information concerning the -hp- Model 3435A Multimeter. Included is an instrument description, specifications, information about instrument and manual identification, option and accessory information, and safety considerations.

### 1-3. DESCRIPTION.

1-4. The -hp- Model 3435A is a 3½ digit, five function, autoranging multimeter. The functions are AC and DC Voltage, AC and DC Current and Ohms. All five functions have manually selectable ranges. AC and DC Voltage and Ohms functions may also be automatically ranged by depressing the AUTO pushbutton. Throughout the remain-

der of this manual, the -hp- Model 3435A Multimeter will be referred to as Multimeter.

### 1-5. SPECIFICATIONS.

1-6. Specifications for the Multimeter are listed in Table 1-1. These specifications are the performance standards or limits to which the Multimeter can be tested. Any changes in these specifications due to manufacturing changes, design or traceability to the National Bureau of Standards will be covered by an errata or change sheet. These specifications supersede any prior published specifications. Supplemental information in Table 1-2 is provided to describe general operating characteristics.

### 1-7. INSTRUMENT AND MANUAL IDENTIFICATION.

Table 1-1. Specifications.

| AC VOLTMETER  | DC VOLTMETER                   |             |        |          |     |         |      |         |       |         |        |        |               |                              |                |                              |                  |                               |   |        |             |          |            |       |           |        |           |         |           |          |          |       |                |        |                                |               |                               |
|---|--------------------------------|-------------|--------|----------|-----|---------|------|---------|-------|---------|--------|--------|---------------|------------------------------|----------------|------------------------------|------------------|-------------------------------|---|--------|-------------|----------|------------|-------|-----------|--------|-----------|---------|-----------|----------|----------|-------|----------------|--------|--------------------------------|---------------|-------------------------------|
| <p>AC Converter: Avg. Responding rms calibrated.</p> <table border="1" style="width: 100%; border-collapse: collapse; margin-bottom: 10px;"> <thead> <tr> <th style="width: 50%;">Ranges</th> <th style="width: 50%;">Max Display</th> </tr> </thead> <tbody> <tr> <td>200 mV</td> <td>199.9 mV</td> </tr> <tr> <td>2 V</td> <td>1.999 V</td> </tr> <tr> <td>20 V</td> <td>19.99 V</td> </tr> <tr> <td>200 V</td> <td>199.9 V</td> </tr> <tr> <td>1200 V</td> <td>1199 V</td> </tr> </tbody> </table> <p>Maximum Input: 1700 V (dc + peak ac), 10<sup>7</sup> volt - Hz max.</p> <p>Ranging: Automatic or manual.</p> <p>Sensitivity: 100 μV on 200 mV range.</p> <p>Accuracy: 1 year, 15° to 30°C @ 95% RH.</p> <p>Minimum Reading: 20 digits.</p> <table border="1" style="width: 100%; border-collapse: collapse; margin-bottom: 10px;"> <tbody> <tr> <td style="width: 50%;">30 Hz - 50 Hz</td> <td style="width: 50%;">± 1.5% of reading ± 3 digits</td> </tr> <tr> <td>50 Hz - 20 kHz</td> <td>± 0.3% of reading ± 3 digits</td> </tr> <tr> <td>20 kHz - 100 kHz</td> <td>± 1.5% of reading ± 10 digits</td> </tr> </tbody> </table> <p>Temperature Coefficient: 0° - 15°C and 30° - 55°C<br/>± (0.04% of reading + 0.2 digits) / °C.</p> <p>Input Impedance: Resistance: 5 meg Ω.<br/>Shunt Capacitance: &lt; 50 pF.</p> <p>Input Type: Floating.</p> <p>Response Time: 1.6 seconds to within 3 digits of final value on one range. Add 1.2 seconds for each range change.</p> | Ranges                         | Max Display | 200 mV | 199.9 mV | 2 V | 1.999 V | 20 V | 19.99 V | 200 V | 199.9 V | 1200 V | 1199 V | 30 Hz - 50 Hz | ± 1.5% of reading ± 3 digits | 50 Hz - 20 kHz | ± 0.3% of reading ± 3 digits | 20 kHz - 100 kHz | ± 1.5% of reading ± 10 digits | <table border="1" style="width: 100%; border-collapse: collapse; margin-bottom: 10px;"> <thead> <tr> <th style="width: 50%;">Ranges</th> <th style="width: 50%;">Max Display</th> </tr> </thead> <tbody> <tr> <td>± 200 mV</td> <td>± 199.9 mV</td> </tr> <tr> <td>± 2 V</td> <td>± 1.999 V</td> </tr> <tr> <td>± 20 V</td> <td>± 19.99 V</td> </tr> <tr> <td>± 200 V</td> <td>± 199.9 V</td> </tr> <tr> <td>± 1200 V</td> <td>± 1199 V</td> </tr> </tbody> </table> <p>Maximum Input: 1200 V (dc + peak ac).</p> <p>Ranging: Automatic or manual.</p> <p>Sensitivity: 100 μV on 200 mV range.</p> <p>Polarity: Automatically sensed and displayed.</p> <p>Accuracy: 1 Year 15° to 30°C @ 95% RH.</p> <table border="1" style="width: 100%; border-collapse: collapse; margin-bottom: 10px;"> <thead> <tr> <th style="width: 50%;">Range</th> <th style="width: 50%;">Specifications</th> </tr> </thead> <tbody> <tr> <td>200 mV</td> <td>± (0.1% of reading + 2 digits)</td> </tr> <tr> <td>2 V to 1200 V</td> <td>± (0.1% of reading + 1 digit)</td> </tr> </tbody> </table> <p>Temperature Coefficient: 0° - 15°C and 30° - 55°C<br/>± (.018% reading + 0.1 digit) / °C</p> <p>Input Resistance: 10 meg Ω ± 1%.</p> <p>Input Type: Floating.</p> <p>Normal Mode Rejection: 40 dB at 50 Hz and 60 Hz<br/>± .1 Hz.</p> <p>Effective Common Mode Rejection: With 1 kΩ<br/>unbalance is &gt; 120 dB at 50/60 Hz ± 0.1%.</p> <p>Response Time: &lt; 0.7 seconds to within 1 digit on one range. Add 1 second for each range change.</p> | Ranges | Max Display | ± 200 mV | ± 199.9 mV | ± 2 V | ± 1.999 V | ± 20 V | ± 19.99 V | ± 200 V | ± 199.9 V | ± 1200 V | ± 1199 V | Range | Specifications | 200 mV | ± (0.1% of reading + 2 digits) | 2 V to 1200 V | ± (0.1% of reading + 1 digit) |
| Ranges  | Max Display                    |             |        |          |     |         |      |         |       |         |        |        |               |                              |                |                              |                  |                               |   |        |             |          |            |       |           |        |           |         |           |          |          |       |                |        |                                |               |                               |
| 200 mV  | 199.9 mV                       |             |        |          |     |         |      |         |       |         |        |        |               |                              |                |                              |                  |                               |   |        |             |          |            |       |           |        |           |         |           |          |          |       |                |        |                                |               |                               |
| 2 V   | 1.999 V                        |             |        |          |     |         |      |         |       |         |        |        |               |                              |                |                              |                  |                               |   |        |             |          |            |       |           |        |           |         |           |          |          |       |                |        |                                |               |                               |
| 20 V  | 19.99 V                        |             |        |          |     |         |      |         |       |         |        |        |               |                              |                |                              |                  |                               |   |        |             |          |            |       |           |        |           |         |           |          |          |       |                |        |                                |               |                               |
| 200 V   | 199.9 V                        |             |        |          |     |         |      |         |       |         |        |        |               |                              |                |                              |                  |                               |   |        |             |          |            |       |           |        |           |         |           |          |          |       |                |        |                                |               |                               |
| 1200 V  | 1199 V                         |             |        |          |     |         |      |         |       |         |        |        |               |                              |                |                              |                  |                               |   |        |             |          |            |       |           |        |           |         |           |          |          |       |                |        |                                |               |                               |
| 30 Hz - 50 Hz   | ± 1.5% of reading ± 3 digits   |             |        |          |     |         |      |         |       |         |        |        |               |                              |                |                              |                  |                               |   |        |             |          |            |       |           |        |           |         |           |          |          |       |                |        |                                |               |                               |
| 50 Hz - 20 kHz  | ± 0.3% of reading ± 3 digits   |             |        |          |     |         |      |         |       |         |        |        |               |                              |                |                              |                  |                               |   |        |             |          |            |       |           |        |           |         |           |          |          |       |                |        |                                |               |                               |
| 20 kHz - 100 kHz  | ± 1.5% of reading ± 10 digits  |             |        |          |     |         |      |         |       |         |        |        |               |                              |                |                              |                  |                               |   |        |             |          |            |       |           |        |           |         |           |          |          |       |                |        |                                |               |                               |
| Ranges  | Max Display                    |             |        |          |     |         |      |         |       |         |        |        |               |                              |                |                              |                  |                               |   |        |             |          |            |       |           |        |           |         |           |          |          |       |                |        |                                |               |                               |
| ± 200 mV  | ± 199.9 mV                     |             |        |          |     |         |      |         |       |         |        |        |               |                              |                |                              |                  |                               |   |        |             |          |            |       |           |        |           |         |           |          |          |       |                |        |                                |               |                               |
| ± 2 V   | ± 1.999 V                      |             |        |          |     |         |      |         |       |         |        |        |               |                              |                |                              |                  |                               |   |        |             |          |            |       |           |        |           |         |           |          |          |       |                |        |                                |               |                               |
| ± 20 V  | ± 19.99 V                      |             |        |          |     |         |      |         |       |         |        |        |               |                              |                |                              |                  |                               |   |        |             |          |            |       |           |        |           |         |           |          |          |       |                |        |                                |               |                               |
| ± 200 V   | ± 199.9 V                      |             |        |          |     |         |      |         |       |         |        |        |               |                              |                |                              |                  |                               |   |        |             |          |            |       |           |        |           |         |           |          |          |       |                |        |                                |               |                               |
| ± 1200 V  | ± 1199 V                       |             |        |          |     |         |      |         |       |         |        |        |               |                              |                |                              |                  |                               |   |        |             |          |            |       |           |        |           |         |           |          |          |       |                |        |                                |               |                               |
| Range   | Specifications                 |             |        |          |     |         |      |         |       |         |        |        |               |                              |                |                              |                  |                               |   |        |             |          |            |       |           |        |           |         |           |          |          |       |                |        |                                |               |                               |
| 200 mV  | ± (0.1% of reading + 2 digits) |             |        |          |     |         |      |         |       |         |        |        |               |                              |                |                              |                  |                               |   |        |             |          |            |       |           |        |           |         |           |          |          |       |                |        |                                |               |                               |
| 2 V to 1200 V   | ± (0.1% of reading + 1 digit)  |             |        |          |     |         |      |         |       |         |        |        |               |                              |                |                              |                  |                               |   |        |             |          |            |       |           |        |           |         |           |          |          |       |                |        |                                |               |                               |

Table 1-1. Specifications (Cont'd).

| <b>AC CURRENT</b>  |  |   |   |                |               |                |              |                  |               |                  |                |                  |              |                  |               |                  |         |                                       |   |                                     |                              |   |               |   |             |                |                             |  |               |   |                      |             |              |             |              |               |   |              |                |                      |                                    |             |                                    |           |                          |                      |   |        |             |                   |                     |            |                |             |                |              |                |               |               |
|--|--|---|---|----------------|---------------|----------------|--------------|------------------|---------------|------------------|----------------|------------------|--------------|------------------|---------------|------------------|---------|---------------------------------------|---|-------------------------------------|------------------------------|---|---------------|---|-------------|----------------|-----------------------------|--|---------------|---|----------------------|-------------|--------------|-------------|--------------|---------------|---|--------------|----------------|----------------------|------------------------------------|-------------|------------------------------------|-----------|--------------------------|----------------------|---|--------|-------------|-------------------|---------------------|------------|----------------|-------------|----------------|--------------|----------------|---------------|---------------|
| <table border="1" style="width: 100%; border-collapse: collapse; margin-bottom: 10px;"> <thead> <tr> <th style="text-align: left;">Ranges</th> <th style="text-align: left;">Max Display</th> </tr> </thead> <tbody> <tr> <td>200 <math>\mu</math>A</td> <td>199.9 <math>\mu</math>A</td> </tr> <tr> <td>2 mA</td> <td>1.999 mA</td> </tr> <tr> <td>20 mA</td> <td>19.99 mA</td> </tr> <tr> <td>200 mA</td> <td>199.9 mA</td> </tr> <tr> <td>2000 mA</td> <td>1999 mA</td> </tr> </tbody> </table> <p>Maximum Input: 2A from &lt; 250 V source.<br/>                     Protection: 2A/250 V fuse (normal blow).<br/>                     Ranging: Manual only.<br/>                     Sensitivity: 100 nA on 200 <math>\mu</math>A range.<br/>                     Accuracy: With display of <math>\geq</math> 20 digits.<br/>                     1 year 15 to 30°C 95% RH.</p> <div style="text-align: center; margin: 10px 0;"> <p>Specifications</p> <table border="1" style="width: 100%; border-collapse: collapse;"> <thead> <tr> <th style="text-align: left;">Range</th> <th style="text-align: center;">30 Hz</th> <th style="text-align: center;">50 Hz</th> <th style="text-align: center;">10 kHz</th> </tr> </thead> <tbody> <tr> <td style="text-align: center;">2000 mA</td> <td style="text-align: center;"><math>\pm</math> 2% of reading<br/><math>\pm</math> 4 digits</td> <td colspan="2" style="text-align: center;"><math>\pm</math> 1.2% of reading<br/><math>\pm</math> 4 digits</td> </tr> <tr> <td style="text-align: center;">200 mA</td> <td colspan="2" style="text-align: center;"><math>\pm</math> 1.7% of reading<br/><math>\pm</math> 4 digits</td> <td style="text-align: center;"><math>\pm</math> 0.9% of reading<br/><math>\pm</math> 4 digits</td> </tr> <tr> <td style="text-align: center;">200 <math>\mu</math>A</td> <td colspan="3"></td> </tr> </tbody> </table> </div> <p>Temperature Coefficient: 0 - 15°C and 30 - 55°C<br/> <math>\pm</math> (0.05% of reading + 0.2 digits) / °C.<br/>                     Voltage Burden:</p> <table border="1" style="width: 100%; border-collapse: collapse; margin: 10px 0;"> <thead> <tr> <th style="text-align: left;">Range</th> <th style="text-align: left;">Max Burden at Full Scale</th> </tr> </thead> <tbody> <tr> <td>200 <math>\mu</math>A to 20 mA</td> <td>&lt; 220 mV</td> </tr> <tr> <td>200 mA</td> <td>&lt; 240 mV</td> </tr> <tr> <td>2000 mA</td> <td>&lt; 400 mV</td> </tr> </tbody> </table> <p>Input Type: Floating.<br/>                     Response Time: 1.6 seconds on any range to within 3 digits.</p>  | Ranges                                     | Max Display                             | 200 $\mu$ A                             | 199.9 $\mu$ A  | 2 mA          | 1.999 mA       | 20 mA        | 19.99 mA         | 200 mA        | 199.9 mA         | 2000 mA        | 1999 mA          | Range        | 30 Hz            | 50 Hz         | 10 kHz           | 2000 mA | $\pm$ 2% of reading<br>$\pm$ 4 digits | $\pm$ 1.2% of reading<br>$\pm$ 4 digits |                                     | 200 mA                       | $\pm$ 1.7% of reading<br>$\pm$ 4 digits |               | $\pm$ 0.9% of reading<br>$\pm$ 4 digits | 200 $\mu$ A |                |                             |  | Range         | Max Burden at Full Scale                  | 200 $\mu$ A to 20 mA | < 220 mV    | 200 mA       | < 240 mV    | 2000 mA      | < 400 mV      | <p>Polarity: Automatically sensed and displayed.<br/>                     Accuracy: 1 year, 15 to 30°C @ 95% RH.</p> <table border="1" style="width: 100%; border-collapse: collapse; margin: 10px 0;"> <thead> <tr> <th style="text-align: left;">Range</th> <th style="text-align: left;">Specifications</th> </tr> </thead> <tbody> <tr> <td>200 <math>\mu</math>A to 20 mA</td> <td><math>\pm</math> (0.3% of reading + 2 digits)</td> </tr> <tr> <td>2000 mA</td> <td><math>\pm</math> (0.6% of reading + 2 digits)</td> </tr> </tbody> </table> <p>Temperature Coefficient: 0 - 15°C and 30 - 55°C<br/> <math>\pm</math> (.028% of reading + 0.1 digits) / °C.<br/>                     Voltage Burden:</p> <table border="1" style="width: 100%; border-collapse: collapse; margin: 10px 0;"> <thead> <tr> <th style="text-align: left;">Range</th> <th style="text-align: left;">Max Burden at Full Scale</th> </tr> </thead> <tbody> <tr> <td>200 <math>\mu</math>A to 20 mA</td> <td>&lt; 220 mV</td> </tr> <tr> <td>200 mA</td> <td>&lt; 240 mV</td> </tr> <tr> <td>2000 mA</td> <td>&lt; 400 mV</td> </tr> </tbody> </table> <p>Input Type: Floating.<br/>                     Response Time: 0.7 seconds on one range to within 1 digit.</p> | Range        | Specifications | 200 $\mu$ A to 20 mA | $\pm$ (0.3% of reading + 2 digits) | 2000 mA     | $\pm$ (0.6% of reading + 2 digits) | Range     | Max Burden at Full Scale | 200 $\mu$ A to 20 mA | < 220 mV  | 200 mA | < 240 mV    | 2000 mA           | < 400 mV            |            |                |             |                |              |                |               |               |
| Ranges   | Max Display                                |   |   |                |               |                |              |                  |               |                  |                |                  |              |                  |               |                  |         |                                       |   |                                     |                              |   |               |   |             |                |                             |  |               |   |                      |             |              |             |              |               |   |              |                |                      |                                    |             |                                    |           |                          |                      |   |        |             |                   |                     |            |                |             |                |              |                |               |               |
| 200 $\mu$ A  | 199.9 $\mu$ A                              |   |   |                |               |                |              |                  |               |                  |                |                  |              |                  |               |                  |         |                                       |   |                                     |                              |   |               |   |             |                |                             |  |               |   |                      |             |              |             |              |               |   |              |                |                      |                                    |             |                                    |           |                          |                      |   |        |             |                   |                     |            |                |             |                |              |                |               |               |
| 2 mA   | 1.999 mA                                   |   |   |                |               |                |              |                  |               |                  |                |                  |              |                  |               |                  |         |                                       |   |                                     |                              |   |               |   |             |                |                             |  |               |   |                      |             |              |             |              |               |   |              |                |                      |                                    |             |                                    |           |                          |                      |   |        |             |                   |                     |            |                |             |                |              |                |               |               |
| 20 mA  | 19.99 mA                                   |   |   |                |               |                |              |                  |               |                  |                |                  |              |                  |               |                  |         |                                       |   |                                     |                              |   |               |   |             |                |                             |  |               |   |                      |             |              |             |              |               |   |              |                |                      |                                    |             |                                    |           |                          |                      |   |        |             |                   |                     |            |                |             |                |              |                |               |               |
| 200 mA   | 199.9 mA                                   |   |   |                |               |                |              |                  |               |                  |                |                  |              |                  |               |                  |         |                                       |   |                                     |                              |   |               |   |             |                |                             |  |               |   |                      |             |              |             |              |               |   |              |                |                      |                                    |             |                                    |           |                          |                      |   |        |             |                   |                     |            |                |             |                |              |                |               |               |
| 2000 mA  | 1999 mA                                    |   |   |                |               |                |              |                  |               |                  |                |                  |              |                  |               |                  |         |                                       |   |                                     |                              |   |               |   |             |                |                             |  |               |   |                      |             |              |             |              |               |   |              |                |                      |                                    |             |                                    |           |                          |                      |   |        |             |                   |                     |            |                |             |                |              |                |               |               |
| Range  | 30 Hz                                      | 50 Hz                                   | 10 kHz                                  |                |               |                |              |                  |               |                  |                |                  |              |                  |               |                  |         |                                       |   |                                     |                              |   |               |   |             |                |                             |  |               |   |                      |             |              |             |              |               |   |              |                |                      |                                    |             |                                    |           |                          |                      |   |        |             |                   |                     |            |                |             |                |              |                |               |               |
| 2000 mA  | $\pm$ 2% of reading<br>$\pm$ 4 digits      | $\pm$ 1.2% of reading<br>$\pm$ 4 digits |   |                |               |                |              |                  |               |                  |                |                  |              |                  |               |                  |         |                                       |   |                                     |                              |   |               |   |             |                |                             |  |               |   |                      |             |              |             |              |               |   |              |                |                      |                                    |             |                                    |           |                          |                      |   |        |             |                   |                     |            |                |             |                |              |                |               |               |
| 200 mA   | $\pm$ 1.7% of reading<br>$\pm$ 4 digits    |   | $\pm$ 0.9% of reading<br>$\pm$ 4 digits |                |               |                |              |                  |               |                  |                |                  |              |                  |               |                  |         |                                       |   |                                     |                              |   |               |   |             |                |                             |  |               |   |                      |             |              |             |              |               |   |              |                |                      |                                    |             |                                    |           |                          |                      |   |        |             |                   |                     |            |                |             |                |              |                |               |               |
| 200 $\mu$ A  |  |   |   |                |               |                |              |                  |               |                  |                |                  |              |                  |               |                  |         |                                       |   |                                     |                              |   |               |   |             |                |                             |  |               |   |                      |             |              |             |              |               |   |              |                |                      |                                    |             |                                    |           |                          |                      |   |        |             |                   |                     |            |                |             |                |              |                |               |               |
| Range  | Max Burden at Full Scale                   |   |   |                |               |                |              |                  |               |                  |                |                  |              |                  |               |                  |         |                                       |   |                                     |                              |   |               |   |             |                |                             |  |               |   |                      |             |              |             |              |               |   |              |                |                      |                                    |             |                                    |           |                          |                      |   |        |             |                   |                     |            |                |             |                |              |                |               |               |
| 200 $\mu$ A to 20 mA   | < 220 mV                                   |   |   |                |               |                |              |                  |               |                  |                |                  |              |                  |               |                  |         |                                       |   |                                     |                              |   |               |   |             |                |                             |  |               |   |                      |             |              |             |              |               |   |              |                |                      |                                    |             |                                    |           |                          |                      |   |        |             |                   |                     |            |                |             |                |              |                |               |               |
| 200 mA   | < 240 mV                                   |   |   |                |               |                |              |                  |               |                  |                |                  |              |                  |               |                  |         |                                       |   |                                     |                              |   |               |   |             |                |                             |  |               |   |                      |             |              |             |              |               |   |              |                |                      |                                    |             |                                    |           |                          |                      |   |        |             |                   |                     |            |                |             |                |              |                |               |               |
| 2000 mA  | < 400 mV                                   |   |   |                |               |                |              |                  |               |                  |                |                  |              |                  |               |                  |         |                                       |   |                                     |                              |   |               |   |             |                |                             |  |               |   |                      |             |              |             |              |               |   |              |                |                      |                                    |             |                                    |           |                          |                      |   |        |             |                   |                     |            |                |             |                |              |                |               |               |
| Range  | Specifications                             |   |   |                |               |                |              |                  |               |                  |                |                  |              |                  |               |                  |         |                                       |   |                                     |                              |   |               |   |             |                |                             |  |               |   |                      |             |              |             |              |               |   |              |                |                      |                                    |             |                                    |           |                          |                      |   |        |             |                   |                     |            |                |             |                |              |                |               |               |
| 200 $\mu$ A to 20 mA   | $\pm$ (0.3% of reading + 2 digits)         |   |   |                |               |                |              |                  |               |                  |                |                  |              |                  |               |                  |         |                                       |   |                                     |                              |   |               |   |             |                |                             |  |               |   |                      |             |              |             |              |               |   |              |                |                      |                                    |             |                                    |           |                          |                      |   |        |             |                   |                     |            |                |             |                |              |                |               |               |
| 2000 mA  | $\pm$ (0.6% of reading + 2 digits)         |   |   |                |               |                |              |                  |               |                  |                |                  |              |                  |               |                  |         |                                       |   |                                     |                              |   |               |   |             |                |                             |  |               |   |                      |             |              |             |              |               |   |              |                |                      |                                    |             |                                    |           |                          |                      |   |        |             |                   |                     |            |                |             |                |              |                |               |               |
| Range  | Max Burden at Full Scale                   |   |   |                |               |                |              |                  |               |                  |                |                  |              |                  |               |                  |         |                                       |   |                                     |                              |   |               |   |             |                |                             |  |               |   |                      |             |              |             |              |               |   |              |                |                      |                                    |             |                                    |           |                          |                      |   |        |             |                   |                     |            |                |             |                |              |                |               |               |
| 200 $\mu$ A to 20 mA   | < 220 mV                                   |   |   |                |               |                |              |                  |               |                  |                |                  |              |                  |               |                  |         |                                       |   |                                     |                              |   |               |   |             |                |                             |  |               |   |                      |             |              |             |              |               |   |              |                |                      |                                    |             |                                    |           |                          |                      |   |        |             |                   |                     |            |                |             |                |              |                |               |               |
| 200 mA   | < 240 mV                                   |   |   |                |               |                |              |                  |               |                  |                |                  |              |                  |               |                  |         |                                       |   |                                     |                              |   |               |   |             |                |                             |  |               |   |                      |             |              |             |              |               |   |              |                |                      |                                    |             |                                    |           |                          |                      |   |        |             |                   |                     |            |                |             |                |              |                |               |               |
| 2000 mA  | < 400 mV                                   |   |   |                |               |                |              |                  |               |                  |                |                  |              |                  |               |                  |         |                                       |   |                                     |                              |   |               |   |             |                |                             |  |               |   |                      |             |              |             |              |               |   |              |                |                      |                                    |             |                                    |           |                          |                      |   |        |             |                   |                     |            |                |             |                |              |                |               |               |
| <b>OHMMETER</b>  |  |   |   |                |               |                |              |                  |               |                  |                |                  |              |                  |               |                  |         |                                       |   |                                     |                              |   |               |   |             |                |                             |  |               |   |                      |             |              |             |              |               |   |              |                |                      |                                    |             |                                    |           |                          |                      |   |        |             |                   |                     |            |                |             |                |              |                |               |               |
| <table border="1" style="width: 100%; border-collapse: collapse; margin-bottom: 10px;"> <thead> <tr> <th style="text-align: left;">Ranges</th> <th style="text-align: left;">Max Display</th> </tr> </thead> <tbody> <tr> <td>20 <math>\Omega</math></td> <td>19.99 <math>\Omega</math></td> </tr> <tr> <td>200 <math>\Omega</math></td> <td>199.9 <math>\Omega</math></td> </tr> <tr> <td>2 k<math>\Omega</math></td> <td>1.999 k<math>\Omega</math></td> </tr> <tr> <td>20 k<math>\Omega</math></td> <td>19.99 k<math>\Omega</math></td> </tr> <tr> <td>200 k<math>\Omega</math></td> <td>199.9 k<math>\Omega</math></td> </tr> <tr> <td>2 M<math>\Omega</math></td> <td>1.999 M<math>\Omega</math></td> </tr> <tr> <td>20 M<math>\Omega</math></td> <td>19.99 M<math>\Omega</math></td> </tr> </tbody> </table> <p>Input Protection: 250 V rms.<br/>                     Ranging: Automatic, or manual.<br/>                     Sensitivity: 10 milliohm on 20 <math>\Omega</math> range.<br/>                     Accuracy: 1 year 15 to 30°C at 95% RH.</p> <table border="1" style="width: 100%; border-collapse: collapse; margin: 10px 0;"> <thead> <tr> <th style="text-align: left;">Range</th> <th style="text-align: left;">Specification</th> </tr> </thead> <tbody> <tr> <td>20 <math>\Omega</math></td> <td><math>\pm</math> (0.5% of reading + 10 digits)</td> </tr> <tr> <td>200 <math>\Omega</math> to 2 M<math>\Omega</math></td> <td><math>\pm</math> (0.2% of reading + 2 digits)</td> </tr> <tr> <td>20 M<math>\Omega</math></td> <td><math>\pm</math> (0.8% of reading + 2 digits)</td> </tr> </tbody> </table> <p>Temperature Coefficient: 0 - 15°C and 30 - 55°C.</p> <table border="1" style="width: 100%; border-collapse: collapse; margin: 10px 0;"> <thead> <tr> <th style="text-align: left;">Range</th> <th style="text-align: left;">Specifications</th> </tr> </thead> <tbody> <tr> <td>20 <math>\Omega</math> to 2 M<math>\Omega</math></td> <td><math>\pm</math> (0.04% of reading + 0.2 digits) / °C</td> </tr> <tr> <td>20 M<math>\Omega</math></td> <td><math>\pm</math> (.18% of reading + 0.2 digits) / °C</td> </tr> </tbody> </table> <p>Configuration: 2 wire.<br/>                     Open Circuit Voltage: &lt; 5 V max.<br/>                     Current through unknown:</p> <table border="1" style="width: 100%; border-collapse: collapse; margin: 10px 0;"> <thead> <tr> <th style="text-align: left;">Range</th> <th>20<math>\Omega</math></th> <th>200<math>\Omega</math></th> <th>2k<math>\Omega</math></th> <th>20k<math>\Omega</math></th> <th>200k<math>\Omega</math></th> <th>2M<math>\Omega</math></th> <th>20M<math>\Omega</math></th> </tr> </thead> <tbody> <tr> <td style="text-align: left;">Current</td> <td>5mA</td> <td>5mA</td> <td>500<math>\mu</math>A</td> <td>50<math>\mu</math>A</td> <td>5<math>\mu</math>A</td> <td>500nA</td> <td>50nA</td> </tr> </tbody> </table> <p>Response Time: 0.8 seconds to within 1 digit. Add 0.8 seconds for each range change.</p> | Ranges                                     | Max Display                             | 20 $\Omega$                             | 19.99 $\Omega$ | 200 $\Omega$  | 199.9 $\Omega$ | 2 k $\Omega$ | 1.999 k $\Omega$ | 20 k $\Omega$ | 19.99 k $\Omega$ | 200 k $\Omega$ | 199.9 k $\Omega$ | 2 M $\Omega$ | 1.999 M $\Omega$ | 20 M $\Omega$ | 19.99 M $\Omega$ | Range   | Specification                         | 20 $\Omega$                             | $\pm$ (0.5% of reading + 10 digits) | 200 $\Omega$ to 2 M $\Omega$ | $\pm$ (0.2% of reading + 2 digits)      | 20 M $\Omega$ | $\pm$ (0.8% of reading + 2 digits)      | Range       | Specifications | 20 $\Omega$ to 2 M $\Omega$ | $\pm$ (0.04% of reading + 0.2 digits) / °C | 20 M $\Omega$ | $\pm$ (.18% of reading + 0.2 digits) / °C | Range                | 20 $\Omega$ | 200 $\Omega$ | 2k $\Omega$ | 20k $\Omega$ | 200k $\Omega$ | 2M $\Omega$   | 20M $\Omega$ | Current        | 5mA                  | 5mA                                | 500 $\mu$ A | 50 $\mu$ A                         | 5 $\mu$ A | 500nA                    | 50nA                 | <p><b>DC CURRENT</b></p> <table border="1" style="width: 100%; border-collapse: collapse; margin-bottom: 10px;"> <thead> <tr> <th style="text-align: left;">Ranges</th> <th style="text-align: left;">Max Display</th> </tr> </thead> <tbody> <tr> <td><math>\pm</math> 200 <math>\mu</math>A</td> <td><math>\pm</math> 199.9 <math>\mu</math>A</td> </tr> <tr> <td><math>\pm</math> 2 mA</td> <td><math>\pm</math> 1.999 mA</td> </tr> <tr> <td><math>\pm</math> 20 mA</td> <td><math>\pm</math> 19.99 mA</td> </tr> <tr> <td><math>\pm</math> 200 mA</td> <td><math>\pm</math> 199.9 mA</td> </tr> <tr> <td><math>\pm</math> 2000 mA</td> <td><math>\pm</math> 1999 mA</td> </tr> </tbody> </table> <p>Maximum Input: 2A from &lt; 250 V source.<br/>                     Protection: 2A/250 V fuse (normal blow).<br/>                     Ranging: Manual only.<br/>                     Sensitivity: 10 nA on 200 <math>\mu</math>A range.</p> | Ranges | Max Display | $\pm$ 200 $\mu$ A | $\pm$ 199.9 $\mu$ A | $\pm$ 2 mA | $\pm$ 1.999 mA | $\pm$ 20 mA | $\pm$ 19.99 mA | $\pm$ 200 mA | $\pm$ 199.9 mA | $\pm$ 2000 mA | $\pm$ 1999 mA |
| Ranges   | Max Display                                |   |   |                |               |                |              |                  |               |                  |                |                  |              |                  |               |                  |         |                                       |   |                                     |                              |   |               |   |             |                |                             |  |               |   |                      |             |              |             |              |               |   |              |                |                      |                                    |             |                                    |           |                          |                      |   |        |             |                   |                     |            |                |             |                |              |                |               |               |
| 20 $\Omega$  | 19.99 $\Omega$                             |   |   |                |               |                |              |                  |               |                  |                |                  |              |                  |               |                  |         |                                       |   |                                     |                              |   |               |   |             |                |                             |  |               |   |                      |             |              |             |              |               |   |              |                |                      |                                    |             |                                    |           |                          |                      |   |        |             |                   |                     |            |                |             |                |              |                |               |               |
| 200 $\Omega$   | 199.9 $\Omega$                             |   |   |                |               |                |              |                  |               |                  |                |                  |              |                  |               |                  |         |                                       |   |                                     |                              |   |               |   |             |                |                             |  |               |   |                      |             |              |             |              |               |   |              |                |                      |                                    |             |                                    |           |                          |                      |   |        |             |                   |                     |            |                |             |                |              |                |               |               |
| 2 k $\Omega$   | 1.999 k $\Omega$                           |   |   |                |               |                |              |                  |               |                  |                |                  |              |                  |               |                  |         |                                       |   |                                     |                              |   |               |   |             |                |                             |  |               |   |                      |             |              |             |              |               |   |              |                |                      |                                    |             |                                    |           |                          |                      |   |        |             |                   |                     |            |                |             |                |              |                |               |               |
| 20 k $\Omega$  | 19.99 k $\Omega$                           |   |   |                |               |                |              |                  |               |                  |                |                  |              |                  |               |                  |         |                                       |   |                                     |                              |   |               |   |             |                |                             |  |               |   |                      |             |              |             |              |               |   |              |                |                      |                                    |             |                                    |           |                          |                      |   |        |             |                   |                     |            |                |             |                |              |                |               |               |
| 200 k $\Omega$   | 199.9 k $\Omega$                           |   |   |                |               |                |              |                  |               |                  |                |                  |              |                  |               |                  |         |                                       |   |                                     |                              |   |               |   |             |                |                             |  |               |   |                      |             |              |             |              |               |   |              |                |                      |                                    |             |                                    |           |                          |                      |   |        |             |                   |                     |            |                |             |                |              |                |               |               |
| 2 M $\Omega$   | 1.999 M $\Omega$                           |   |   |                |               |                |              |                  |               |                  |                |                  |              |                  |               |                  |         |                                       |   |                                     |                              |   |               |   |             |                |                             |  |               |   |                      |             |              |             |              |               |   |              |                |                      |                                    |             |                                    |           |                          |                      |   |        |             |                   |                     |            |                |             |                |              |                |               |               |
| 20 M $\Omega$  | 19.99 M $\Omega$                           |   |   |                |               |                |              |                  |               |                  |                |                  |              |                  |               |                  |         |                                       |   |                                     |                              |   |               |   |             |                |                             |  |               |   |                      |             |              |             |              |               |   |              |                |                      |                                    |             |                                    |           |                          |                      |   |        |             |                   |                     |            |                |             |                |              |                |               |               |
| Range  | Specification                              |   |   |                |               |                |              |                  |               |                  |                |                  |              |                  |               |                  |         |                                       |   |                                     |                              |   |               |   |             |                |                             |  |               |   |                      |             |              |             |              |               |   |              |                |                      |                                    |             |                                    |           |                          |                      |   |        |             |                   |                     |            |                |             |                |              |                |               |               |
| 20 $\Omega$  | $\pm$ (0.5% of reading + 10 digits)        |   |   |                |               |                |              |                  |               |                  |                |                  |              |                  |               |                  |         |                                       |   |                                     |                              |   |               |   |             |                |                             |  |               |   |                      |             |              |             |              |               |   |              |                |                      |                                    |             |                                    |           |                          |                      |   |        |             |                   |                     |            |                |             |                |              |                |               |               |
| 200 $\Omega$ to 2 M $\Omega$   | $\pm$ (0.2% of reading + 2 digits)         |   |   |                |               |                |              |                  |               |                  |                |                  |              |                  |               |                  |         |                                       |   |                                     |                              |   |               |   |             |                |                             |  |               |   |                      |             |              |             |              |               |   |              |                |                      |                                    |             |                                    |           |                          |                      |   |        |             |                   |                     |            |                |             |                |              |                |               |               |
| 20 M $\Omega$  | $\pm$ (0.8% of reading + 2 digits)         |   |   |                |               |                |              |                  |               |                  |                |                  |              |                  |               |                  |         |                                       |   |                                     |                              |   |               |   |             |                |                             |  |               |   |                      |             |              |             |              |               |   |              |                |                      |                                    |             |                                    |           |                          |                      |   |        |             |                   |                     |            |                |             |                |              |                |               |               |
| Range  | Specifications                             |   |   |                |               |                |              |                  |               |                  |                |                  |              |                  |               |                  |         |                                       |   |                                     |                              |   |               |   |             |                |                             |  |               |   |                      |             |              |             |              |               |   |              |                |                      |                                    |             |                                    |           |                          |                      |   |        |             |                   |                     |            |                |             |                |              |                |               |               |
| 20 $\Omega$ to 2 M $\Omega$  | $\pm$ (0.04% of reading + 0.2 digits) / °C |   |   |                |               |                |              |                  |               |                  |                |                  |              |                  |               |                  |         |                                       |   |                                     |                              |   |               |   |             |                |                             |  |               |   |                      |             |              |             |              |               |   |              |                |                      |                                    |             |                                    |           |                          |                      |   |        |             |                   |                     |            |                |             |                |              |                |               |               |
| 20 M $\Omega$  | $\pm$ (.18% of reading + 0.2 digits) / °C  |   |   |                |               |                |              |                  |               |                  |                |                  |              |                  |               |                  |         |                                       |   |                                     |                              |   |               |   |             |                |                             |  |               |   |                      |             |              |             |              |               |   |              |                |                      |                                    |             |                                    |           |                          |                      |   |        |             |                   |                     |            |                |             |                |              |                |               |               |
| Range  | 20 $\Omega$                                | 200 $\Omega$                            | 2k $\Omega$                             | 20k $\Omega$   | 200k $\Omega$ | 2M $\Omega$    | 20M $\Omega$ |                  |               |                  |                |                  |              |                  |               |                  |         |                                       |   |                                     |                              |   |               |   |             |                |                             |  |               |   |                      |             |              |             |              |               |   |              |                |                      |                                    |             |                                    |           |                          |                      |   |        |             |                   |                     |            |                |             |                |              |                |               |               |
| Current  | 5mA  | 5mA                                     | 500 $\mu$ A                             | 50 $\mu$ A     | 5 $\mu$ A     | 500nA          | 50nA         |                  |               |                  |                |                  |              |                  |               |                  |         |                                       |   |                                     |                              |   |               |   |             |                |                             |  |               |   |                      |             |              |             |              |               |   |              |                |                      |                                    |             |                                    |           |                          |                      |   |        |             |                   |                     |            |                |             |                |              |                |               |               |
| Ranges   | Max Display                                |   |   |                |               |                |              |                  |               |                  |                |                  |              |                  |               |                  |         |                                       |   |                                     |                              |   |               |   |             |                |                             |  |               |   |                      |             |              |             |              |               |   |              |                |                      |                                    |             |                                    |           |                          |                      |   |        |             |                   |                     |            |                |             |                |              |                |               |               |
| $\pm$ 200 $\mu$ A  | $\pm$ 199.9 $\mu$ A                        |   |   |                |               |                |              |                  |               |                  |                |                  |              |                  |               |                  |         |                                       |   |                                     |                              |   |               |   |             |                |                             |  |               |   |                      |             |              |             |              |               |   |              |                |                      |                                    |             |                                    |           |                          |                      |   |        |             |                   |                     |            |                |             |                |              |                |               |               |
| $\pm$ 2 mA   | $\pm$ 1.999 mA                             |   |   |                |               |                |              |                  |               |                  |                |                  |              |                  |               |                  |         |                                       |   |                                     |                              |   |               |   |             |                |                             |  |               |   |                      |             |              |             |              |               |   |              |                |                      |                                    |             |                                    |           |                          |                      |   |        |             |                   |                     |            |                |             |                |              |                |               |               |
| $\pm$ 20 mA  | $\pm$ 19.99 mA                             |   |   |                |               |                |              |                  |               |                  |                |                  |              |                  |               |                  |         |                                       |   |                                     |                              |   |               |   |             |                |                             |  |               |   |                      |             |              |             |              |               |   |              |                |                      |                                    |             |                                    |           |                          |                      |   |        |             |                   |                     |            |                |             |                |              |                |               |               |
| $\pm$ 200 mA   | $\pm$ 199.9 mA                             |   |   |                |               |                |              |                  |               |                  |                |                  |              |                  |               |                  |         |                                       |   |                                     |                              |   |               |   |             |                |                             |  |               |   |                      |             |              |             |              |               |   |              |                |                      |                                    |             |                                    |           |                          |                      |   |        |             |                   |                     |            |                |             |                |              |                |               |               |
| $\pm$ 2000 mA  | $\pm$ 1999 mA                              |   |   |                |               |                |              |                  |               |                  |                |                  |              |                  |               |                  |         |                                       |   |                                     |                              |   |               |   |             |                |                             |  |               |   |                      |             |              |             |              |               |   |              |                |                      |                                    |             |                                    |           |                          |                      |   |        |             |                   |                     |            |                |             |                |              |                |               |               |



**1-14. SAFETY CONSIDERATIONS.**

1-15. This Operating and Service Manual contains cautions and warnings alerting the user to hazardous operating and maintenance conditions. This information is flagged by a caution or warning heading and/or the symbol . The

 symbol appears on the front panel and is an international symbol meaning “refer to the Operating and Service Manual”. This symbol flags important operating instructions located in Section III. To ensure the safety of the operating and maintenance personnel and retain the operating condition of the instrument, these instructions must be adhered to.

## SECTION II INSTALLATION

### 2-1. INTRODUCTION.

2-2. This section contains information and instructions for the installation and shipping of the Multimeter. Included are initial inspection procedures, power and grounding requirements, environmental information, and instructions for repackaging the instrument for shipment.

### 2-3. INITIAL INSPECTION.

2-4. This instrument was carefully inspected both mechanically and electrically before shipment. It should be free of marks or scratches and in perfect electrical order upon receipt. To confirm this, the instrument should be inspected for physical damage in transit. Electrical performance should be tested using the performance test outlined in Section V. If there is damage or deficiency, see the warranty inside the front of this manual.

### 2-5. POWER REQUIREMENTS.

2-6. The Multimeter can be operated from any one of the ac power sources listed in Table 1-2. Before connecting the instrument to ac power, verify that the ac power source matches the power requirement of the instrument as marked on the option label affixed to the rear of the instrument. If the instrument is incompatible with the available power source, refer to Section V for Power Requirement Modification instructions.

### 2-7. ENVIRONMENTAL REQUIREMENTS.

2-8. The Multimeter will meet the specifications listed in Table 1-1 when the operating temperature is within the range of + 15°C to + 30°C. The instrument can be operated where the ambient temperature is within the range of 0°C to + 40°C and the relative humidity is less than 95%.

### WARNING

*To prevent potential electrical or fire hazard, do not expose equipment to rain or moisture.*

### 2-9. REPACKAGING FOR SHIPMENT.

2-10. The following paragraphs contain a general guide for repackaging the instrument for shipment. Refer to Paragraph 2-11 if the original container is to be used; 2-12 if it is not. If you have any questions, contact your nearest -hp- Sales and Service Office (See Appendix A for office locations).

### NOTE

*If the instrument is to be shipped to Hewlett-Packard for service or repair, attach a tag to the instrument identifying the owner and indicating*

*the service or repair to be accomplished. Include the model number and full serial number of the instrument. In any correspondence, identify the instrument by model number and full serial number.*

2-11. Place instrument in original container with appropriate packing material and seal well with strong tape or metal bands. If original container is not available, one can be purchased from your nearest -hp- Sales and Service Office.

2-12. If original container is not to be used, proceed as follows:

- Wrap instrument in heavy paper or plastic before placing in an inner container.
- Place packing material around all sides of instrument and protect front panel with cardboard strips.
- Place instrument and inner container in a heavy carton or wooden box and seal with strong tape or metal bands.

### 2-13. POWER CORDS AND RECEPTACLES.

2-14. Figure 2-1 illustrates the plug cap configurations that are available to provide ac power to the Multimeter. The -hp- part number shown directly below each plug cap drawing is the part number for the power cord set equipped with the appropriate mating plug for that receptacle. The appropriate power cord should be provided with each instrument. However, if a different power cord set is required, notify the nearest -hp- Sales and Service Office and a replacement cord will be provided. The instrument ac power input receptacle and cord set appliance coupler meet the safety specifications set by the International Commission on Rules for the Approval of Electrical Equipment (CEE 22).

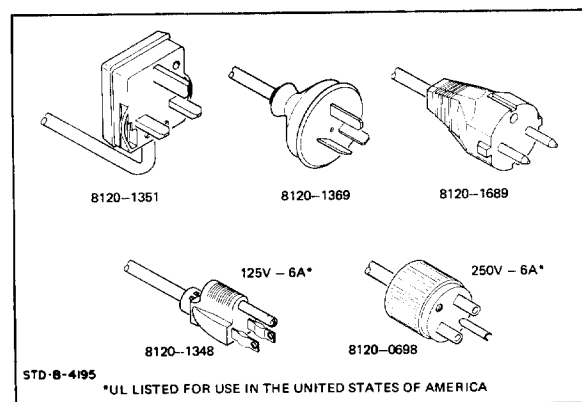

Figure 2-1. Power Receptacles.

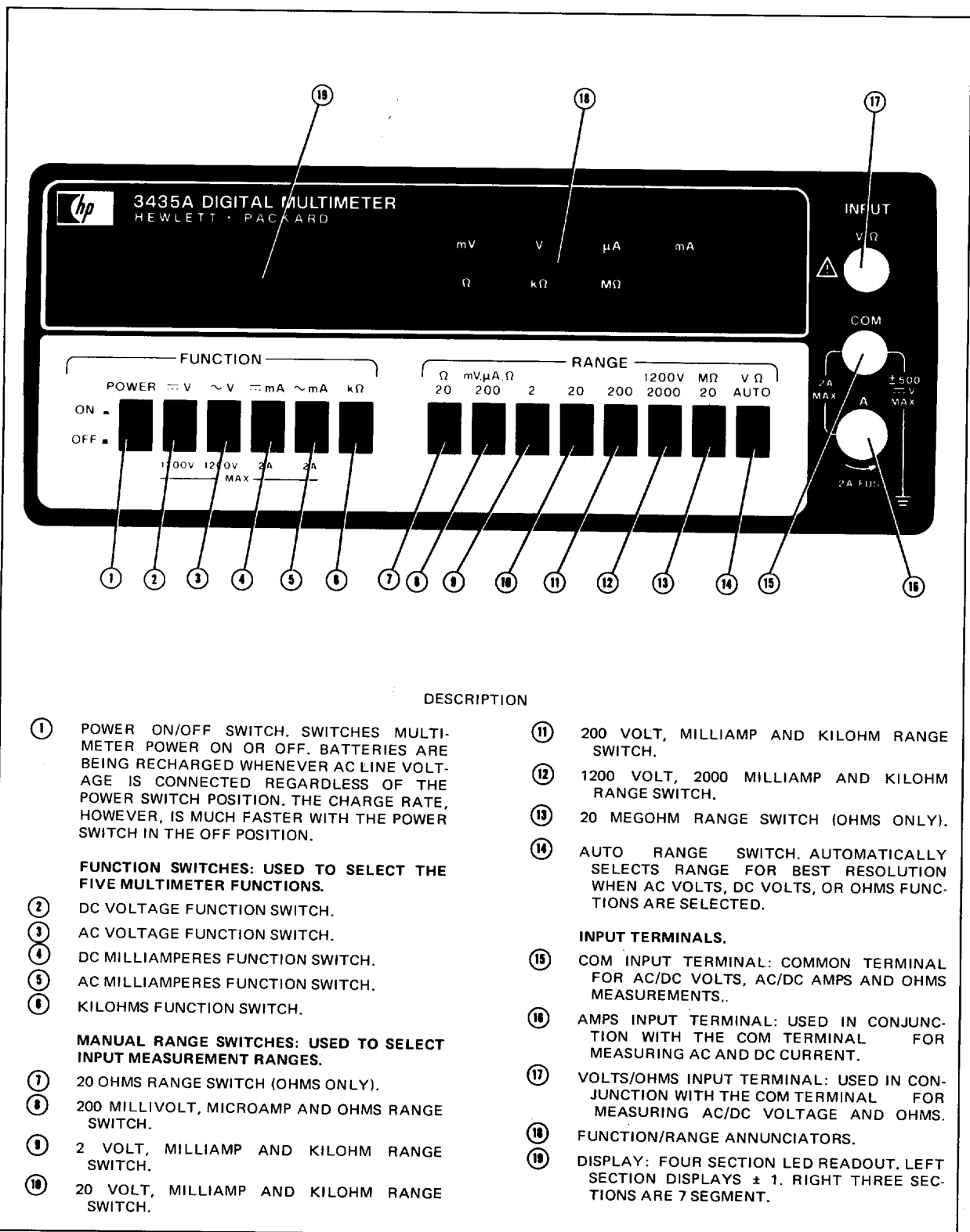

Figure 3-1. Description on Controls and Connectors.

## SECTION III OPERATING INSTRUCTIONS

### 3-1. INTRODUCTION.

3-2. This section contains instructions for operating the Multimeter. Measurements of ac and dc voltage, ac and dc current, and ohms are discussed. A description of the controls and connectors is given in Figure 3-1.

#### WARNING

*To prevent potential electrical or fire hazard, do not expose the Multimeter or its accessories to rain or moisture.*

### 3-3. AC Operation.

3-4. Before connecting the Multimeter to ac power, verify that the ac power source matches the power requirements of the Multimeter as marked on the option label affixed to the rear of the instrument. If the instrument is incompatible with the available power source, refer to Section V of this manual for power requirement modification instructions. After this verification, connect the proper ac power to the instrument and press the ON button. The instrument is ready for use.

### 3-5. Battery Operation.

**3-6. Recharging the Battery.** Before operating the Multimeter in the Battery Mode, ensure that the battery is charged. Connect the Multimeter to the proper ac line voltage and allow 12 hours for a full recharge with the POWER switch off (out). This provides a minimum operating time of 10 hours. A 4 hour recharge will allow an operating time of 8 hours. Operating the instrument with the proper ac line voltage connected and the POWER switch on, provides a full battery recharge in 16 hours.

#### NOTE

*Repeated partial charge cycles may result in a temporary loss of battery capacity. Normal capacity can be restored by fully charging the battery.*

**3-7. Low Battery Voltage.** The Multimeter will operate in Battery Mode when the battery voltage is greater than 5.6 V. This voltage is measured through the access hole on the bottom of the Multimeter. To accomplish this perform the following procedure:

- a. Disconnect ac line voltage.
- b. Select dcV function and 20 V range.

- c. Insert the V -  $\Omega$  test probe into the access hole as shown in Figure 3-2.

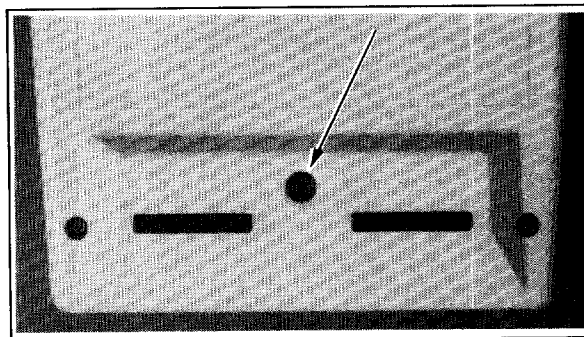

**Figure 3-2. Battery Voltage Access Hole.**

3-8. If the battery voltage drops below 5.6 volts, the Multimeter will automatically stop operating (blank display) to prevent damage to the battery. If this occurs, set the POWER switch to OFF and recharge the battery.

3-9. If the display has blanked due to low battery voltage, and there is a requirement to make one or two more measurements before recharging the battery, set the POWER switch to OFF for approximately 15 minutes and then make the measurement. This allows the battery to partially rejuvenate.

### 3-10. Overload/Overage/Improper Function Indication.

3-11. Figure 3-3 shows the display indication during overload, overrange, or an improper switch setting.

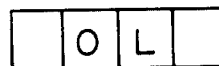

**Figure 3-3. Overload Indication.**

3-12. Table 3-1 lists improper switch combinations.

**Table 3-1. Improper Switch Combinations.**

| Function | Range          |                  |
|----------|----------------|------------------|
| ⎓ mA     | $\Omega$<br>20 | M $\Omega$<br>20 |
| ~ mA     | $\Omega$<br>20 | M $\Omega$<br>20 |
| ⎓ V      | $\Omega$<br>20 | M $\Omega$<br>20 |
| ~ V      | $\Omega$<br>20 | M $\Omega$<br>20 |
| ⎓ mA     | Auto           |                  |
| ~ mA     | Auto           |                  |

**3-13. Auto.**

3-14. Depressing the AUTO switch with acV, dcV or k $\Omega$  function selected sets the Multimeter in an automatic ranging mode. In this mode the Multimeter will *uprange* if the display reading increases above (+) or (-)  $\boxed{1999}$  and *downrange* if the display decreases below (+) or (-)  $\boxed{1180}$ . These numerical autoranging points are irrespective of decimal placement. The difference between the two autoranging points is called autoranging hysteresis. Figure 3-4 shows the autoranging points for dc voltage measurements from 0 to 1200 Vdc. Autoranging in other Multimeter functions is similar.

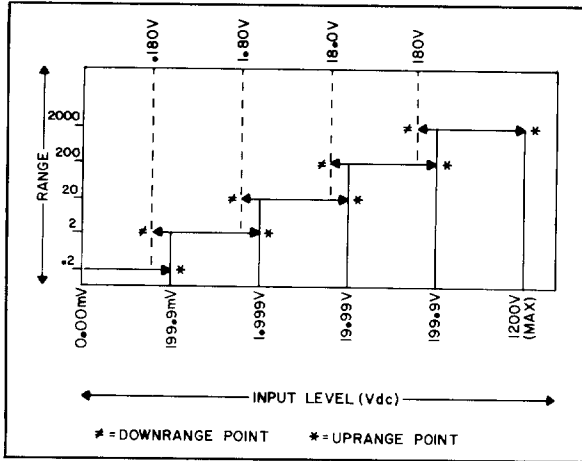

Figure 3-4. Multimeter Autoranging.

3-15. To release the AUTO switch depress one of the MANUAL RANGE switches.

**3-16. Input Terminals.**

3-17. **V $\Omega$  (Volts/Ohms).** The V $\Omega$  terminal is the *high* terminal for ac and dc voltage measurements. For ohms measurements, it is the positive (+) terminal.

3-18. **COM (Common).** The COM terminal is used for all five Multimeter functions. It is the negative (-) terminal for ohms measurements and it is the *low* terminal for ac and dc voltage and current measurements.



To avoid possible damage to the Multimeter circuitry, the voltage between COM and  $\perp$  (earth ground) must not exceed  $\pm 500$  Vdc.

3-19. **A (Amps).** The A terminal is the *high* terminal for ac and dc amps measurements. There is a 2 amp input protection fuse in series with this terminal.



The current function is protected by a fuse of 250 V rating. To avoid damage to the Multimeter, current sources having open circuit voltages greater than 250 V (dc + peak ac) must not be connected to the A (amps) input terminal.

**3-20. AC Voltage Measurements.**



To avoid possible damage to the Multimeter circuitry, the ac input voltage must not exceed 1700 V (dc + peak ac).

**3-21. Procedure:**

- a. Depress  $\sim$  V (ac volts).
- b. Depress proper manual range (200 mV to 1200 V) or depress AUTO for automatic range selection.
- c. Connect test leads from the Multimeter V $\Omega$  (high) and COM (low) terminals to the voltage under test as shown in Figure 3-5.

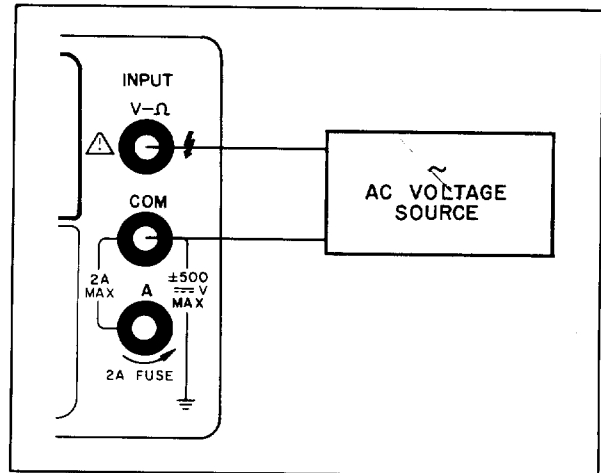

Figure 3-5. AC Voltage Measurement.

**3-22. DC Voltage Measurements.**



To avoid possible damage to the Multimeter circuitry, the dc input voltage must not exceed 1200 V (dc + peak ac).

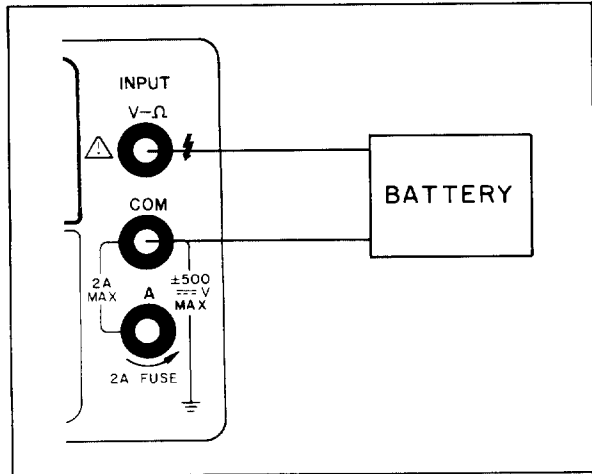

Figure 3-6. DC Voltage Measurements.

**3-23. Procedure:**

- a. Depress  $\text{---} \text{V}$  (dc volts).
- b. Depress proper manual range (200 mV to 1200 V) or depress AUTO for automatic range selection.
- c. Connect test leads from the Multimeter VΩ (high) and COM (low) terminals to the voltage under test as shown in Figure 3-6.

**3-24. AC Current Measurements.**

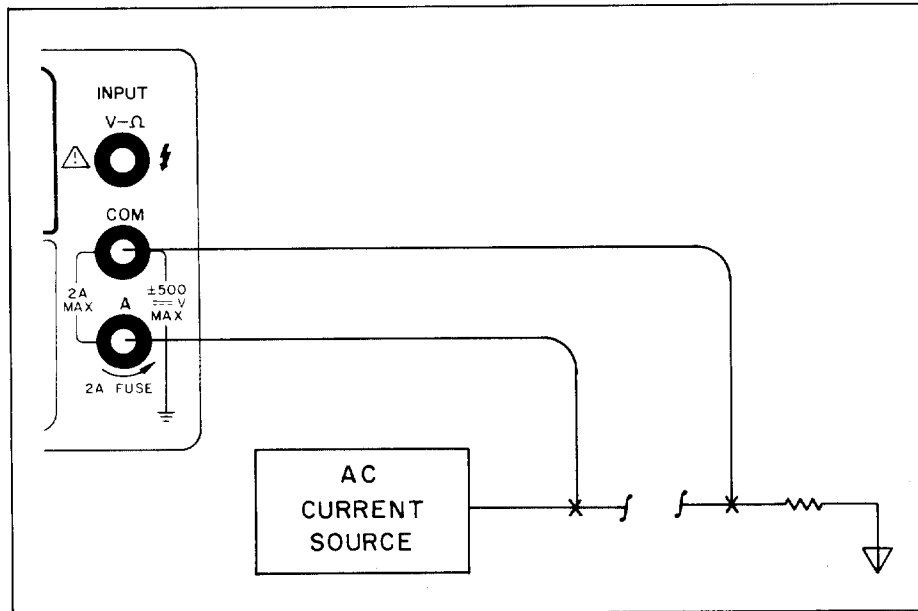

Figure 3-7. AC Current Measurement.



**CAUTION**

The current function is protected by a fuse of 250 V rating. To avoid damage to the Multimeter, current sources having open circuit voltages greater than 250 V (dc + peak ac) must not be connected to the A (amps) input terminal.

**3-25. Procedure:**

- a. Depress  $\sim \text{mA}$  (ac milliamperes).
- b. Depress proper manual range (200  $\mu\text{A}$  to 2000 mA).
- c. Connect test leads from the Multimeter A and COM terminals in series with the current under test as shown in Figure 3-7.

**3-26. DC Current Measurement.**



**CAUTION**

The current function is protected by a fuse of 250 V rating. To avoid damage to the Multimeter, current sources having open circuit voltages greater than 250 V (dc + peak ac) must not be connected to the A (amps) input terminal.

**3-27. Procedure:**

- a. Depress  $\text{---} \text{mA}$  (dc milliamperes).
- b. Depress proper manual range (200  $\mu\text{A}$  to 2000 mA).
- c. Connect test leads from the Multimeter A and COM terminals in series with the current under test as shown in Figure 3-8.

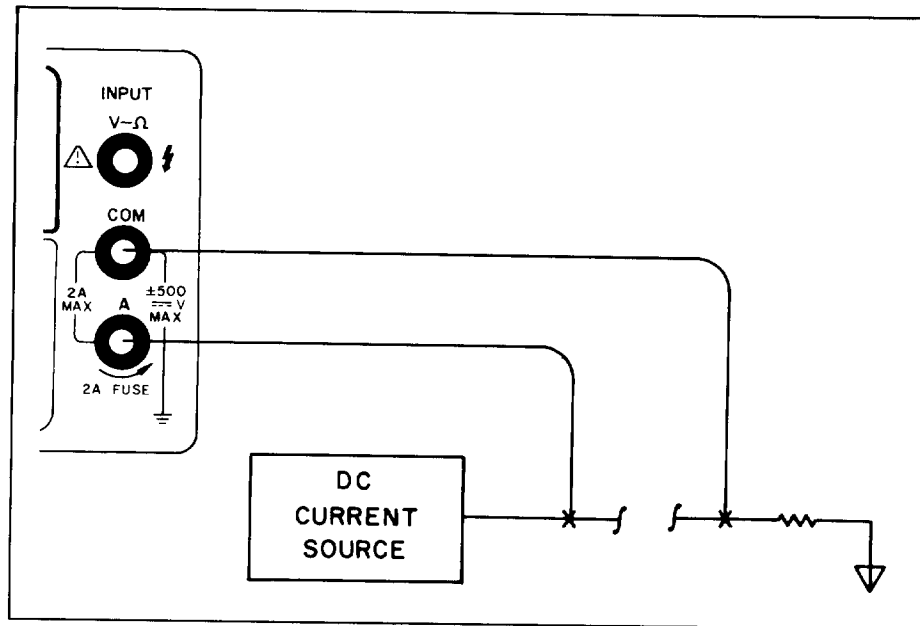

Figure 3-8. DC Current Measurements.

**3-28. Resistance Measurements.****3-29. Procedure:**

- a. Depress  $k\Omega$  (kilohms).
- b. Depress proper manual range ( $20\ \Omega$  to  $20\ M\Omega$ ).
- c. Connect test leads from the Multimeter  $V\Omega$  (+) and COM (-) terminals to the resistance under test as shown in Figure 3-9.

**NOTE**

*When making resistance measurements using the lower ohms ranges, consideration should be given to the resistance of the test leads. This potential measurement error can be eliminated by measuring the lead resistance and subtracting it from the combined resistance value of the test leads and the resistance under test.*

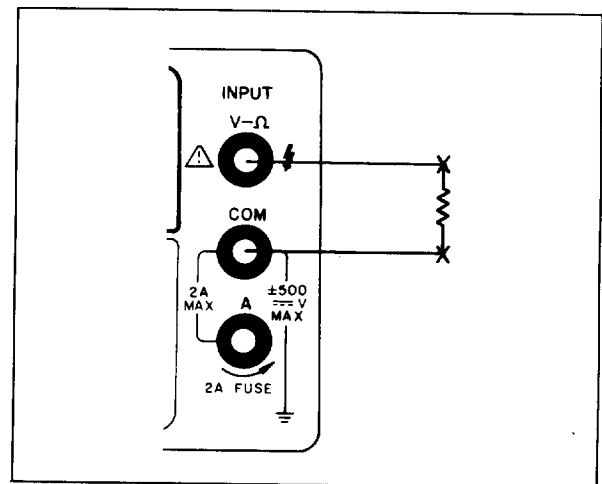

Figure 3-9. Resistance Measurement.

**3-30. Handle/Bail.**

3-31. The Multimeter display viewing angle is adjusted by rotating the Handle/Bail to a convenient position as shown in Figure 3-10.

**3-32. Option Decal.**

3-33. The option decal is affixed to the rear of the Multimeter. An example is shown in Figure 3-11.

**3-34. Information Decal.**

3-35. The information decal shown in Figure 3-12 is affixed to the underside of the Multimeter.

**3-36. Amps Input Fuse Replacement.**

3-37. The amps input is protected by a 2A 250 V fuse, -hp- Part Number 2110-0002. This fuse is easily replaced using the following procedure:

- a. Insert a coin or wide bladed screwdriver into the slots of the A input terminal.
- b. Press the color ring in and rotate it counterclockwise  $1/3$  turn.
- c. Remove and replace the blown fuse.

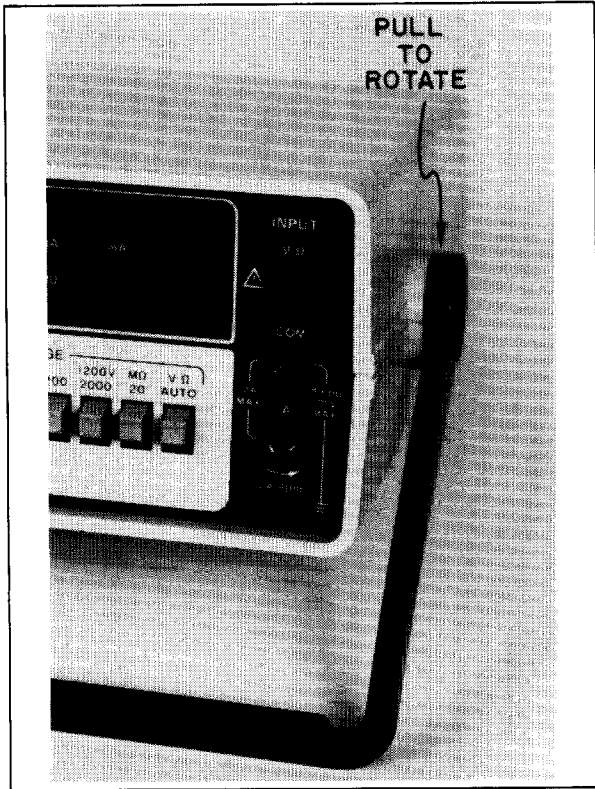

Figure 3-10. Handle/Bail Positioning.

3-38. Multimeter Cleaning.



Do not allow cleaning solvents, flux remover, or alcohol to come in contact with the Multimeter.

3-39. The Multimeter case and front panel should only be cleaned with a mild solution of soap and water and a soft cloth.

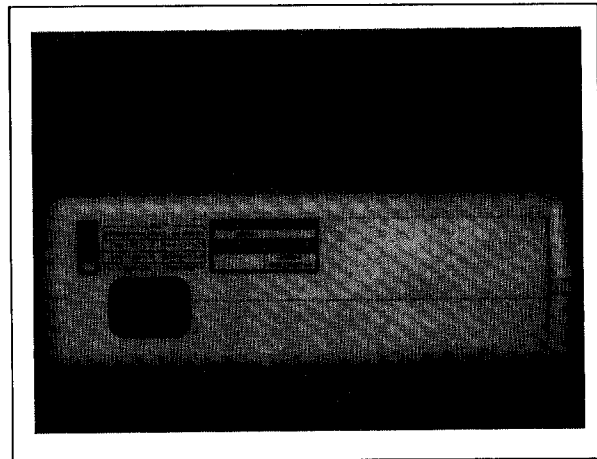

Figure 3-11. Option Decal.

**hp** 3435A DIGITAL MULTIMETER  
HEWLETT-PACKARD

**WARNING:** NO OPERATOR SERVICEABLE PARTS  
INSIDE. REFER TO QUALIFIED PERSONNEL ONLY.

**Ω (OHMS)**

- V ≈ 5 V ⇒ OPEN CIRCUIT.
- PROTECTION: ± 350 V ⇒ OR 250 VRMS.
- FOR BEST ACCURACY ON LOW RESISTANCE RANGES SUBTRACT LEAD RESISTANCE.

| RANGE  | I      | V 1K COUNTS |
|--------|--------|-------------|
| 20 Ω   | 5 mA   | 50 mV       |
| 200 Ω  | 5 mA   | 500 mV      |
| 2 kΩ   | 500 μA | 500 mV      |
| 20 kΩ  | 50 μA  | 500 mV      |
| 200 kΩ | 5 μA   | 500 mV      |
| 2 MΩ   | 500 nA | 500 mV      |
| 20 MΩ  | 50 nA  | 500 mV      |

**~ V (AC VOLTS)**

- MAXIMUM VOLTAGE: 1199 VRMS.
- MAXIMUM INPUTS: 500 V ⇒ 1700 V(⇒ & P ~), 10<sup>7</sup> V - Hz.
- FREQ RANGE: 30 Hz - 100 k Hz.
- CONVERTER: AVERAGE RESPONDING. CALIBRATED IN RMS.

**≡ V (DC VOLTS)**

MAXIMUM VOLTAGE:  
1199 V ⇒

**I (CURRENT) (MANUAL RANGE ONLY)**

I MAX: 1.999A (<math>< 250 \text{ V SOURCE}</math>).

| RANGE  | R     |
|--------|-------|
| 200 μA | 1 kΩ  |
| 2 mA   | 100 Ω |
| 20 mA  | 10 Ω  |
| 200 mA | 1 Ω   |
| 2 A    | 0.1 Ω |

**BATTERY**

| CHARGE TIME |          | RUN TIME |
|-------------|----------|----------|
| INST ON     | INST OFF | @25°C    |
| 2.5 HR.     | 1.5 HR   | 4 HR     |
| 16 HRS      | 12 HR.   | 10 HR    |

CONT CHG WILL NOT HARM BAT.  
5.6 - 6.4V BAT CONTACT BETWEEN RUBBER FEET.

**FUSES**

| FUNCTION  | VALUE               | LOCATION          |
|-----------|---------------------|-------------------|
| ~ LINE    | 125 mA/<br>250 V    | MAIN BD           |
| I BATTERY | 2A/250 V<br>2A/250V | A INPUT<br>BAT BD |

**AUTO RANGE**

UP RANGE  
2000 COUNTS

DOWN RANGE  
179 COUNTS

**SAMPLE RATE**

5/SEC AT 000

2/SEC AT 1999

**'OL' DISPLAY**

OFF SCALE INPUT OR  
IMPROPER SELECTION  
OF FUNCTION AND  
RANGE

NOTE: SHORTING COM TO A STOPS SAMPLING IN ≡ V (DC VOLTS) & ~ V (AC VOLTS).

Figure 3-12. Information Decal.

## SECTION IV THEORY OF OPERATION

### 4-1. INTRODUCTION.

4-2. This section contains the theory of operation for the Multimeter. Included are simplified block diagrams and descriptions of the function of each block.

### 4-3. Simplified Block Diagram Description (Figure 4-1).

4-4. **Input Switching.** The input switching block consists of the Function switches and the Range switches. These switches program the controller using a 3 line function code (FNA, FNB, FNC) and a 4 line range code (MRD, MRE, MRF, Auto).

4-5. **Input Amplifier.** The input amplifier is a multi-gain operational amplifier. It is used for all five input functions. The gain is selected by MOS FET switches which are controlled by the controller (U13) or by the manual range switches.

4-6. **Post Amplifier.** Ac and dc voltages are amplified by the post amplifier. The gain is x1 or x10 and is selected by MOS FET switches. The switching is controlled by the manual range switches or by the controller (U13).

4-7. **AC Converter.** The AC Converter is an average responding detector used in ac voltage and ac current measurements. The output of the AC Converter is a dc voltage equal to the rms value of the ac input voltage. In the ac current function, the input voltage to the converter is the ac voltage drop across the current shunts, times the gain of the input and post amplifiers.

4-8. **Ohms Current Source.** The ohms current source provides ohms reference voltage for the analog to digital

converter and it provides sense current to the "unknown resistance" for each of the 7 ohms ranges.

4-9. **Current Shunts.** The current shunts are used for ac and dc current measurements. The voltage drop across the shunt resistors is the input voltage to the input amplifier in the ac or dc milliams function.

4-10. **Analog to Digital Converter.** The analog to digital converter use the *dual slope integration technique* to translate analog input signals into digital timing pulses.

4-11. **Controller.** The controller processes range and function information and provides digital control to MOS FET switches in the input and post amplifiers and the analog to digital converter. The controller also converts the comparator output (run down time) into appropriate digit and segment drive voltages to operate the display.

4-12. **Display.** The display provides an annunciated digital readout of the input signal using light emitting diodes.

4-13. **Battery Charger.** The battery charger consists of a three cell rechargeable battery, a current limited charger circuit and a digitally controlled ac to dc converter. The battery charger circuitry operates whenever ac line voltage is connected.

4-14. **Power Supply.** The power supply provides dc voltages of +7, -7, -2, and  $V_{DISP}$  to the Multimeter circuitry.  $V_{DISP}$  will be equal to the battery voltage (5.6 V to 6.5 V) for standard configuration instruments.  $V_{DISP}$  will be  $6.4 \pm .2$  for Option 001 and 002 instruments.

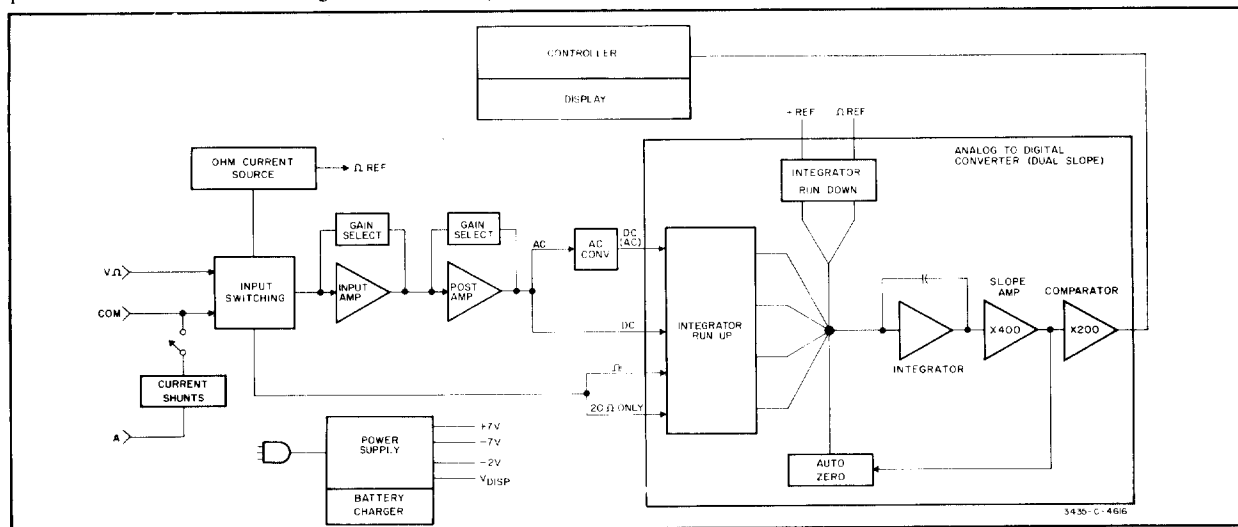

Figure 4-1. Simplified Block Diagram.

## **WARNING**

*These servicing instructions are for use by qualified personnel only. To avoid electrical shock, do not perform any servicing other than that contained in the operating instructions unless you are qualified to do so.*

---

Table 5-1. Test Equipment Required.

| Instrument Type                      | Required Characteristics   | Recommended Model  |
|--------------------------------------|--|--|
| Digital Volt/Ohmmeter                | DC Volts: 1 V, 10 V and 100 V range<br>Accuracy: $\pm 0.04\%$<br>Input Resistance: 10 M $\Omega$<br>Ohms: 20 k $\Omega$<br>Accuracy: $\pm 0.07\%$  | -hp- 3470 System;<br>-hp- 34702A Multimeter  |
| Digital Voltmeter                    | DC Volts: 5 digit resolution to 1 $\mu$ V on<br>100 mV dc range<br>Accuracy: $\pm 0.007\%$<br>AC Volts: 1 V and 10 V range<br>Frequency: 40 Hz to 20 kHz<br>Accuracy: 0.25%  | -hp- 3450B   |
| AC Calibrator/High Voltage Amplifier | Frequency: 20 Hz to 100 kHz<br>Output: 1 mV to 1000 V<br>Accuracy (mid band): $\pm 0.1\%$  | -hp- 745A/746A   |
| DC Standard                          | Output: 1 mV to 1000 V<br>Accuracy: $\pm 0.02\%$   | -hp- 740B  |
| Meter Calibrator                     | Output: 1 A<br>Accuracy: $\pm 0.1\%$   | -hp- 6920B   |
| Electronic Counter                   | Frequency: 50 and 60 Hz<br>Accuracy: $\pm 0.01\%$  | -hp- 5300A/5302A   |
| Power Supply                         | Output: 20 V, 1 A  | -hp- 6294A   |
| Resistor Decade Box                  | 10 $\Omega$ , 100 $\Omega$ , 1 k $\Omega$ , 10 k $\Omega$ , 100 k $\Omega$<br>and 1 M $\Omega$ steps<br>Accuracy: $\pm 0.005\%$  | General Radio<br>Mdl GR 1433-Z   |
| Resistors                            | 1 $\Omega \pm 0.02\%$<br>10 $\Omega \pm 0.01\%$<br>1 k $\Omega \pm 0.01\%$<br>10 k $\Omega \pm 0.01\%$<br>100 k $\Omega \pm 0.01\%$<br>1 M $\Omega \pm 0.01\%$<br>10 M $\Omega \pm 0.1\%$<br>22 k $\Omega \pm 1\%$ | G.R. 1440-9601<br>G.R. 1440-9611<br>G.R. 1440-9631<br>G.R. 1440-9641<br>G.R. 1440-9651<br>G.R. 1440-9661<br>0698-8194<br>0757-1087 |

## SECTION V MAINTENANCE

### 5-1. INTRODUCTION.

5-2. This section of the manual contains Performance Tests and Adjustment Procedures. The Performance Tests are designed to verify the critical specifications listed in Table 1-1. A Performance Test Card is at the end of this section for recording the results of the performance tests.

### 5-3. Test Equipment Required.

5-4. Equipment required for the Performance Tests and Adjustment Procedures is listed in Table 5-1, Recommended Test Equipment. Equipment that satisfies the critical specifications given in the table may be substituted for a recommended model.

### 5-5. PERFORMANCE TESTS.

#### 5-6. AC Voltage Accuracy Test.

5-7. An AC Calibrator and High Voltage Amplifier will be required for this test.



*To avoid possible damage to the Multimeter circuitry, the ac input voltage must not exceed 1700 V (dc + peak ac).*

- a. Set the Multimeter to ac V.
- b. Connect the AC Calibrator as shown in Figure 5-1.
- c. Check the ranges and frequencies listed in Table 5-2 for the tolerances indicated on all ranges through 200 V.

### WARNING

*Use extreme care when checking the following ranges. Establish all connections before turning on the high voltage source. When the tests are completed, turn off the high voltage before disconnecting any cables or test leads.*

- d. To check the 1200 V range, connect the AC Calibrator and High Voltage Amplifier to the Multimeter and check the tolerances indicated for the 1200 V range.

#### 5-8. DC Voltmeter Accuracy Test.

5-9. A DC Standard is required for this test.

- a. Set the Multimeter to measure dc volts.
- b. Connect the DC Standard to the VΩ and COM terminals as shown in Figure 5-2.
- c. Check all the ranges listed in Table 5-3 for the tolerances indicated.

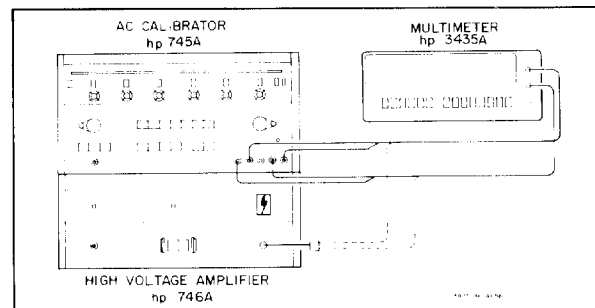

Figure 5-1. AC Voltage Accuracy Test.

Table 5-2. AC Voltage Accuracy Test.

| Range  | AC Standard Output | Test Frequency   | Multimeter Display Limits |
|--------|--------------------|------------------|---------------------------|
| 200 mV | 10 mV              | 30 Hz            | 9.5 to 10.5 mV            |
|        | 10 mV              | 50 Hz            | 9.7 to 10.3 mV            |
|        | 10 mV              | 1 kHz            | 9.7 to 10.3 mV            |
|        | 10 mV              | 10 kHz           | 9.7 to 10.3 mV            |
|        | 10 mV              | 20 kHz           | 9.7 to 10.3 mV            |
|        | 10 mV              | 50 kHz           | 8.8 to 11.2 mV            |
|        | 10 mV              | 100 kHz          | 8.8 to 11.2 mV            |
|        | 50 mV              | 30 Hz            | 49.0 to 51.1 mV           |
|        | 50 mV              | 50 Hz            | 49.5 to 50.5 mV           |
|        | 50 mV              | 20 kHz           | 49.5 to 50.5 mV           |
|        | 50 mV              | 100 kHz          | 48.2 to 51.7 mV           |
|        | 100 mV             | 30 Hz            | 98.2 to 101.8 mV          |
|        | 100 mV             | 50 Hz, 500 Hz    | 99.4 to 100.6 mV          |
|        | 100 mV             | 20 kHz           | 99.4 to 100.6 mV          |
| 100 mV | 100 kHz            | 97.5 to 102.5 mV |                           |
| 2 V    | 1 V                | 30 Hz            | .982 to 1.018 V           |
|        | 1 V                | 50 Hz, 1 kHz     | .994 to 1.006 V           |
|        | 1 V                | 20 kHz           | .994 to 1.006 V           |
|        | 1 V                | 100 kHz          | .975 to 1.025 V           |
| 20 V   | 10 V               | 30 Hz            | 9.82 to 10.18 V           |
|        | 10 V               | 50 Hz, 10 kHz    | 9.94 to 10.06 V           |
|        | 10 V               | 20 kHz           | 9.94 to 10.06 V           |
|        | 10 V               | 100 kHz          | 9.75 to 10.25 V           |
| 200 V  | 100 V              | 30 Hz            | 98.2 to 101.8 V           |
|        | 100 V              | 50 Hz, 15 kHz    | 99.4 to 100.6 V           |
|        | 100 V              | 20 kHz           | 99.4 to 100.6 V           |
|        | 100 V              | 100 kHz          | 97.5 to 102.5 V           |
| 1200 V | 1000 V             | 30 Hz            | 982 to 1018 V             |
|        | 1000 V             | 50 Hz, 1 kHz     | 994 to 1006 V             |
|        | 1000 V             | 10 kHz           | 994 to 1006 V             |

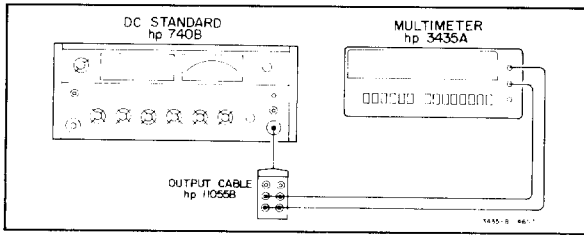

Figure 5-2. DC Voltmeter Accuracy Test.

**CAUTION**

To avoid possible damage to the Multimeter circuitry, the dc input voltage must not exceed 1200 V (dc + peak ac).

Table 5-3. DC Voltage Accuracy Test.

| Range  | DC Standard Output             | Multimeter Display Limits  |
|--------|--------------------------------|--|
| 200 mV | + 10 mV<br>+ 50 mV<br>- 100 mV | + 9.8 to + 10.2 mV<br>+ 49.7 to + 50.25 mV<br>- 99.7 to - 100.3 mV |
| 2 V    | - .1 V<br>+ .5 V<br>+ 1 V      | - .099 to - .101 V<br>+ .498 to + .502 V<br>+ .998 to + 1.002 V    |
| 20 V   | - 2 V<br>- 5 V<br>+ 10 V       | - 1.99 to - 2.01 V<br>- 4.98 to - 5.02 V<br>+ 9.98 to + 10.02 V    |
| 200 V  | + 20 V<br>- 50 V<br>- 100 V    | + 19.9 to + 20.1 V<br>- 49.8 to - 50.2 V<br>- 99.8 to - 100.2 V    |
| 1200 V | + 200 V<br>- 500 V<br>+ 1000 V | + 198 to + 201 V<br>- 498 to - 502 V<br>+ 998 to + 1002 V          |

**5-10. AC Ammeter Accuracy Test.**

a. Connect the equipment as shown in Figure 5-3 using the decade resistor box to select the value of  $R_A$ . Set the

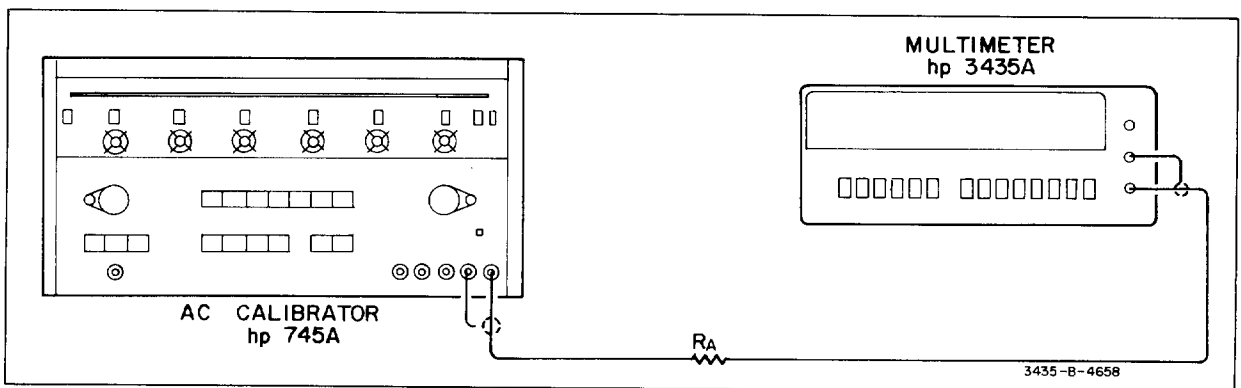

Figure 5-3. AC Ammeter Accuracy Test 200  $\mu$ A thru 20 mA Range.

Multimeter function to ac A ( $\sim$  A). Using the values of  $R_A$  and AC Calibrator outputs shown in Table 5-4, check the 200  $\mu$ A, 2 mA and 20 mA Multimeter ranges at the frequencies listed.

b. To check the 200 mA and 2000 mA ranges, it will be necessary to use an ac current source such as the Model 6920B Meter Calibrator. Disconnect the AC Calibrator and connect the 6920B in its place. Set 6920B OUTPUT SWITCH to OFF.

c. Set the 6920B function to AC and OUTPUT SWITCH to ON HOLD. Check the Multimeter 200 mA range at 20 mA, 50 mA, and 100 mA for the tolerances listed in Table 5-5. Return the OUTPUT SWITCH on the 6290B to OFF before changing any ranges.

d. Change the 6920B and Multimeter ranges to 2000 mA (2A). Set the calibrator OUTPUT switch to ON HOLD and check the Multimeter 2000 mA range at levels of 100 mA, 500 mA and 1000 mA for the tolerances listed in Table 5-5.

**5-11. DC Ammeter Accuracy Test.**

5-12. This test requires the use of a power supply, a DC Standard and a precision resistor listed in Table 5-6 (part numbers are given in Table 5-1) or a resistor decade box.

a. Connect the Multimeter and test equipment as shown in Figure 5-4.

b. Connect the 100 kilohm  $\pm$  0.01% resistor in the  $R_A$  position as shown.

c. Set the Multimeter function to DCA ( $\equiv$  A) and range to 200  $\mu$ A. Adjust the power supply output for a differential voltmeter reading of 1.000 V. The Multimeter should indicate 9.8 to 10.2  $\mu$ A.

d. Check all the Multimeter ranges, using the values of  $R_A$  and differential voltmeter readings shown in Table 5-6. The Multimeter display should indicate within the limits provided.

**Table 5-4. AC Ammeter Accuracy Test, 200  $\mu$ A thru 20 mA Ranges.**

| Range       | AC Calibrator Output Level | AC Calibrator Frequency | $R_A$ Value              | Current Level | Multimeter Display Limits                  |
|-------------|----------------------------|-------------------------|--------------------------|---------------|--|
| 200 $\mu$ A | 1 V                        | 30 Hz<br>50 Hz, 10 kHz  | 100 k $\Omega$ $\pm$ .1% | 10 $\mu$ A    | 9.4 to 10.6 $\mu$ A<br>9.5 to 10.5 $\mu$ A |
| 2 mA        | 10 V                       | 30 Hz<br>50 Hz, 10 kHz  | 100 k $\Omega$ $\pm$ .1% | .1 mA         | .094 to .106 mA<br>.095 to .105 mA         |
| 20 mA       | 10 V                       | 30 Hz<br>50 Hz, 10 kHz  | 10 k $\Omega$ $\pm$ 0.1% | 1 mA          | .94 to 1.06 mA<br>.95 to 1.05 mA           |

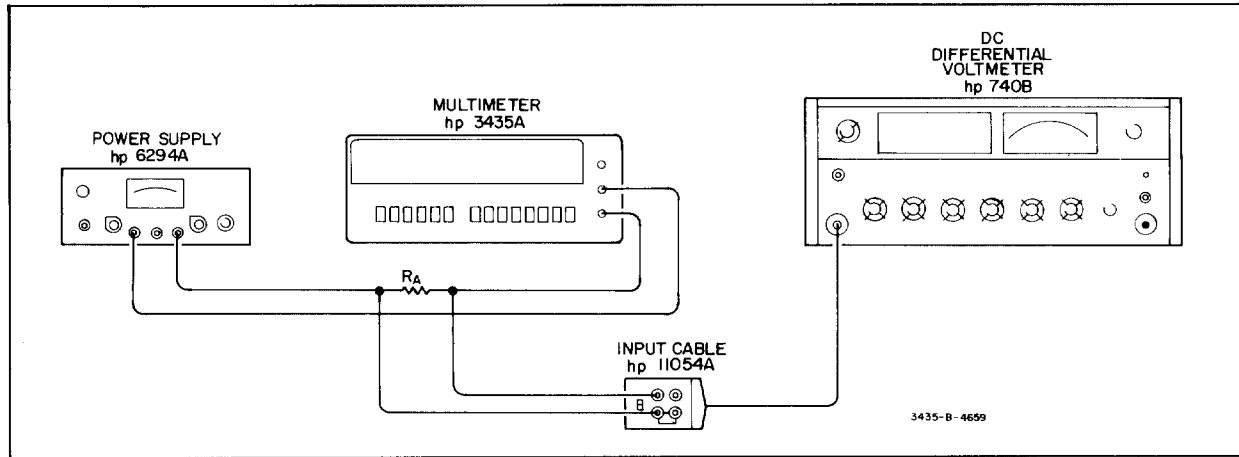

**Figure 5-4. DC Ammeter Accuracy Test.**

**Table 5-5.**

**AC Ammeter Accuracy Test, 200 mA and 2000 mA Ranges.**

| Range   | Output Meter Calibration | Multimeter Display Limits |
|---------|--------------------------|---------------------------|
| 200 mA  | 20 mA                    | 19.4 to 20.6 mA           |
|         | 50 mA                    | 49.1 to 50.9 mA           |
|         | 100 mA                   | 98.7 to 101.3 mA          |
| 2000 mA | 100 mA                   | 95 to 105 mA              |
|         | 500 mA                   | 490 to 510 mA             |
|         | 1000 mA                  | 984 to 1016 mA            |

**5-13. Ohms Accuracy Test.**

5-14. A precision resistive decade box will be required for this test. It should be calibrated and have a known accuracy of .005%.

- Connect the equipment as shown in Figure 5-5.
- Set the Multimeter function to OHMS ( $\Omega$ ) and check all the ranges in Table 5-7 using the decade box to supply the indicated resistances. The Multimeter display should indicate within the limits provided.

**5-15. AC Normal-Mode Rejection Test.**

5-16. AC normal-mode rejection is the ratio of the peak normal-mode voltage to the resultant error in reading.

$$NMR_{(db)} = 20 \log_{10} \frac{\text{Peak ac superimposed voltage}}{\text{Effect on reading (peak volts)}}$$

An AC Calibrator and Electronic Counter are required for this test.

- Connect the test equipment as shown in Figure 5-6. Do not connect the Multimeter at this time.
- Using the Electronic Counter as a monitor, adjust the AC Calibrator frequency to 60 Hz  $\pm$  0.1% (Period = 16650 to 16683  $\mu$ s).
- Set the Multimeter function to dcV ( $\equiv$ V) and range to 20 V. Short the Multimeter input and note the indication.
- Disconnect the short and connect the AC Calibrator to the Multimeter input. Adjust the Calibrator output to 7.07 V rms (10 V peak).
- The Multimeter indication should not vary more than 100 mV from the indication noted in Step C. This verifies a normal-mode rejection of greater than 40 dB.
- Repeat Steps c, d and e for an AC Calibrator output frequency of 50 Hz  $\pm$  0.1% as monitored by the Electronic Counter (Period = 1998 to 20020  $\mu$ s).

Table 5-6. DC Ammeter Accuracy Test.

| Range   | Current Level               | R <sub>A</sub>    | Differential VM Reading          | Multimeter Display Limits                              |
|---------|-----------------------------|-------------------|----------------------------------|--|
| 200 μA  | 10 μA<br>50 μA<br>100 μA    | 100 kΩ<br>± 0.01% | 1.0000 V<br>5.0000 V<br>10.000 V | 9.8 to 10.2 μA<br>49.6 to 50.4 μA<br>99.5 to 100.5 μA  |
| 2 mA    | .1 mA<br>.5 mA<br>1 mA      | 1 kΩ<br>± 0.01%   | .10000 V<br>.50000 V<br>1.0000 V | .098 to .102 mA<br>.496 to .503 mA<br>.995 to 1.005 mA |
| 20 mA   | 1 mA<br>5 mA<br>10 mA       | 1 kΩ<br>± 0.01%   | 1.0000 V<br>5.0000 V<br>10.000 V | .98 to 1.02 mA<br>4.96 to 5.04 mA<br>9.95 to 10.05 mA  |
| 200 mA  | 10 mA<br>50 mA<br>100 mA    | 10 Ω<br>± 0.01%   | .10000 V<br>.5000 V<br>1.0000 V  | 9.8 to 10.2 mA<br>49.6 to 50.4 mA<br>99.5 to 100.5 mA  |
| 2000 mA | 100 mA<br>500 mA<br>1000 mA | 1 Ω<br>± 0.02%    | .10000 V<br>.50000 V<br>1.0000 V | 97 to 103 mA<br>495 to 505 mA<br>992 to 1008 mA        |

Table 5-7. Ohms Accuracy Test.

| Range          | Standard Resistance                  | Multimeter Display Limits                              |
|----------------|--------------------------------------|--|
| 20 Ω           | 1 Ω<br>5 Ω<br>10 Ω                   | .89 to 1.11 Ω<br>4.87 to 5.13 Ω<br>9.85 to 10.15 Ω     |
| 200 Ω          | 10 Ω<br>50 Ω<br>100 Ω                | 9.8 to 10.2 Ω<br>49.7 to 50.3 Ω<br>99.6 to 100.4 Ω     |
| 2 kΩ           | 200 Ω (.2 k)<br>500 Ω (.5 k)<br>1 kΩ | .198 to .202 kΩ<br>.497 to .503 kΩ<br>.996 to 1.004 kΩ |
| 20 kΩ          | 2 kΩ<br>5 kΩ<br>10 kΩ                | 1.98 to 2.02 kΩ<br>4.97 to 5.03 kΩ<br>9.96 to 10.04 kΩ |
| 200 kΩ         | 20 kΩ<br>50 kΩ<br>100 kΩ             | 19.8 to 20.2 kΩ<br>49.7 to 50.3 kΩ<br>99.6 to 100.4 kΩ |
| 2000 kΩ (2 MΩ) | 200 kΩ<br>500 kΩ<br>1000 kΩ          | 198 to 202 kΩ<br>497 to 503 kΩ<br>996 to 1004 kΩ       |
| 20 MΩ          | 1 MΩ<br>5 MΩ<br>10 MΩ                | .97 to 1.03 MΩ<br>4.94 to 5.06 MΩ<br>9.90 to 10.10 MΩ  |

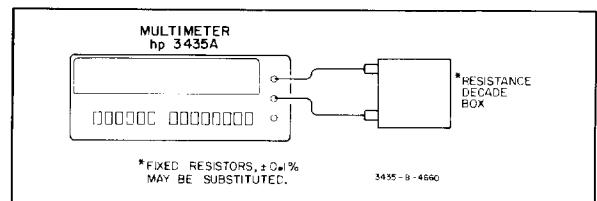

Figure 5-5. Ohms Accuracy Test.

input terminals. ECMR is normally measured in decibels and can be calculated by the following formula:

$$ECMR \text{ (dB)} = 20 \log_{10} \frac{\text{Peak common-mode voltage}}{\text{Effect on reading (peak volts)}}$$

- a. Connect a 1 kΩ resistor between the V/Ω and COM terminals.
- b. Set the Multimeter function to dcV (---V) and range to 200 mV. Note the Multimeter indication.
- c. Connect an AC Calibrator as shown in Figure 5-7 and set the output amplitude to 100 V at 60 Hz ± 1 Hz. (Period = 16650 to 16683 μs.)
- d. Note the Multimeter indication. The indication should not vary more than 0.1 mV from the reading noted in Step b. This verifies an ECMR of greater than 120 dB.
- e. Repeat Steps c and d with the AC Calibrator frequency set to 50 Hz ± 1%. (Period = 1998 to 20020 μs.)

**5-17. Effective Common-Mode Rejection Test.**

5-18. Effective Common-Mode Rejection (ECMR) is a measure of the ability of the Multimeter to reject dc voltages of equal amplitude applied simultaneously to both voltage

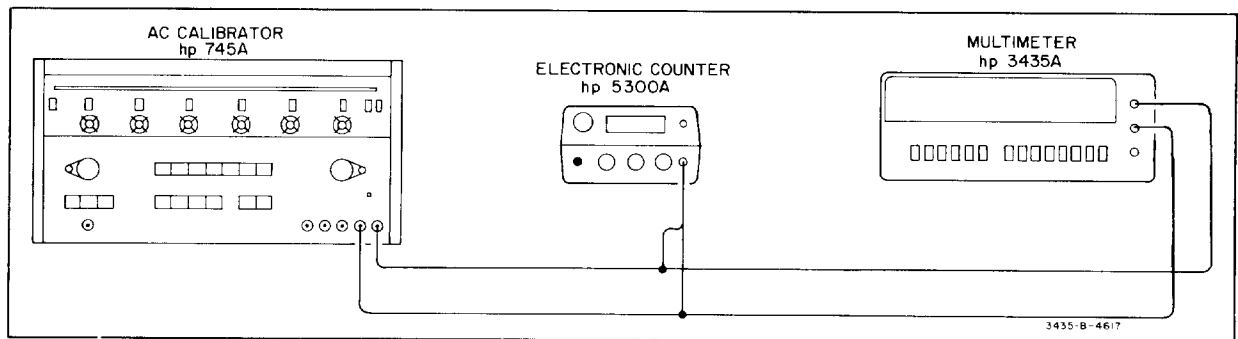

Figure 5-6. AC Normal-Mode Rejection Test.

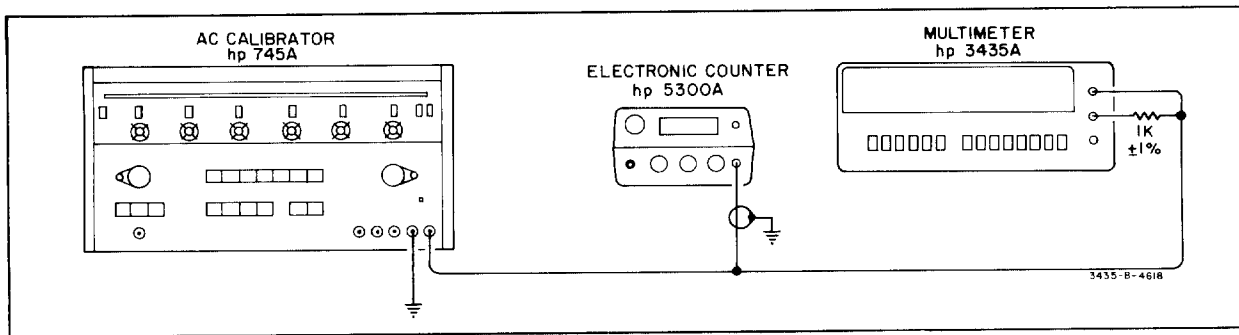

Figure 5-7. Effective Common-Mode Rejection Test.

**WARNING**

*These servicing instructions are for use by qualified personnel only. To avoid electrical shock, do not perform any servicing other than that contained in the operating instructions unless you are qualified to do so.*

**CAUTION**

*Wear clean cotton gloves when working on the main assembly circuit board or switches. Contamination of fingerprints on high impedance points on the main assembly will degrade the performance of the instrument. Nylon gloves should not be worn due to the possibility of static charge buildup.*

**CAUTION**

*The hybrid circuits in the Multimeter may be permanently damaged by static discharge from a hand or tool when the Multimeter is disassembled. The procedures below must be followed to prevent possible damage.*

1. Ground the hand while disassembling and working on the Multimeter. Conductive wristbands (-hp- Part No. 00970-67900) are available for this purpose.
2. Attach the Multimeter COM terminal to earth ground. Touch all tools to earth ground to remove static charges before using them on the Multimeter.
3. Use a soldering iron with a grounded tip.

**PRE-ADJUSTMENT PROCEDURES.**

**A. Disassembly Instructions.**

1. Remove the Multimeter Power Cord.
2. With the Multimeter in the inverted position, remove the four screws from the bottom cover.
3. Carefully return the Multimeter to the upright position with the front panel facing you.

**NOTE**

*Battery and charger circuitry are located in the top shell and are connected to the main PC assembly by an 8 lead cable. To avoid possible damage to the cable or connectors, remove top cover slowly.*

4. Remove the top shell vertically and place it at the right side of the lower shell in an inverted position. This will allow access to all internal adjustments while still being able to observe the display and change the switch settings.

**B. Turn-On Instructions.**

1. Connect the Multimeter ground jumper to earth ground.
2. Use ac line voltage to power the Multimeter while making adjustments.

**5-19. ADJUSTMENT PROCEDURE.**

5-20. Refer to foldout Figure 5-11 for the following adjustments.

**NOTE**

*Do not deviate from the adjustment sequence of this procedure.*

**5-21. ① + 7 V Power Supply Adjustment (R417).**

- Connect a dc Digital Voltmeter (DVM) to the + end of C407.
- Adjust R417 for a dc DVM reading of 7 volts.

**5-22. Battery Charge Voltage Adjustment (R818).**

- Disconnect ac line voltage.
- Lift one end of battery fuse F801 to open the battery circuit.
- Connect dc DVM to positive battery terminal.
- Connect ac line voltage and set the POWER switch to ON.
- Adjust R818 for a dc DVM reading of 7.2 volts.

**5-23. ② Clock Frequency Adjustment (R9).**

- Connect a 10 M $\Omega$  (10:1 divider) oscilloscope probe from the 5300A/5302A frequency counter input to JM2 on the Multimeter A1 PC assembly.
- Adjust R9 for a frequency counter reading of 9980 Hz to 10020 Hz (10 kHz  $\pm$  .2%).

**5-24. ③ AC Zero Adjustment (R203).**

- Set the Multimeter to acV, 20 V range.
- Connect a short across the V/ $\Omega$  to COM terminals.
- Adjust R203 for a Multimeter display reading of 00.0 V.

**5-25. ④ 29 Ohms Zero Adjustment (R111).**

- Set the Multimeter to k $\Omega$ , 20  $\Omega$  range.
- Connect a short across the V/ $\Omega$  to COM terminals.

**NOTE**

*Use a low resistance short comprised of heavy copper wire soldered across a double banana connector.*

- Adjust R111 for a Multimeter display reading of 0.00 ohms.

**5-26. ⑤ DC Gain Adjustment (R403).**

- Set the Multimeter to dcV, 20 V range.
- Set the 740B dc standard as follows:

|                |            |
|----------------|------------|
| Function       | Std        |
| Range          | 100 V      |
| Output voltage | 19.000 (V) |

- Connect the 740B output to the Multimeter input as shown in Figure 5-8.
- Adjust R403 for a Multimeter display reading of 19.00 V.

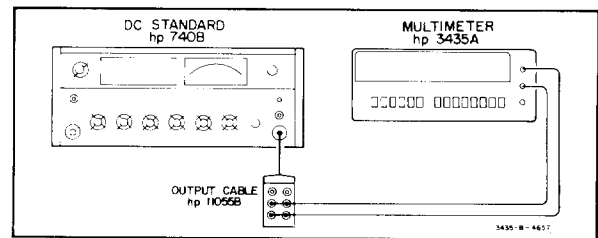

Figure 5-8. DC Gain Adjustment.

**5-27. ⑥ Ohms Gain Adjustment (R119).**

- Set the Multimeter to k $\Omega$ , 20 k $\Omega$  range.
- Set the GR 1433Z Decade Resistor to 19 k $\Omega$  and connect it across the V/ $\Omega$  to COM terminals.
- Adjust R119 for a Multimeter display reading of 19.00 k $\Omega$ .

**5-28. ⑦ AC Gain Adjustment (R123).**

- Set the Multimeter to acV, 20 V range.
- Set the 745A AC Calibrator as follows:

|                |                |
|----------------|----------------|
| Frequency      | 200 Hz         |
| Voltage range  | 100 V          |
| Output voltage | 19.0000 V (ac) |

- Connect the 745A to the Multimeter as shown in Figure 5-9.
- Adjust R123 for a Multimeter display reading of 19.00 V.

**5-29. ⑧ 20 V Range, 20 kHz Adjustment (R102).**

- Set the Multimeter to acV, 20 V range.

b. Set the 745A AC Calibrator as follows:

- Frequency 20 kHz
- Voltage range 100 V
- Output voltage 19.0000 V (ac)

c. Connect the 745A to the Multimeter as shown in Figure 5-9.

d. Adjust R102 for a Multimeter display reading of 19.00 V.

**5-30. ⑨ 2 V Range, 20 kHz Adjustment (R110).**

**5-31. POWER REQUIREMENT MODIFICATION INSTRUCTIONS.**

5-32. There are four different line voltage configurations available for the Multimeter. To change line voltage requirements, arrange resistors R421 through R425 to accommodate the desired line voltage as shown in Figure 5-10.

**NOTE**

*A jumper (short) may be substituted for the 2.7 ohm resistors (R421-R425).*

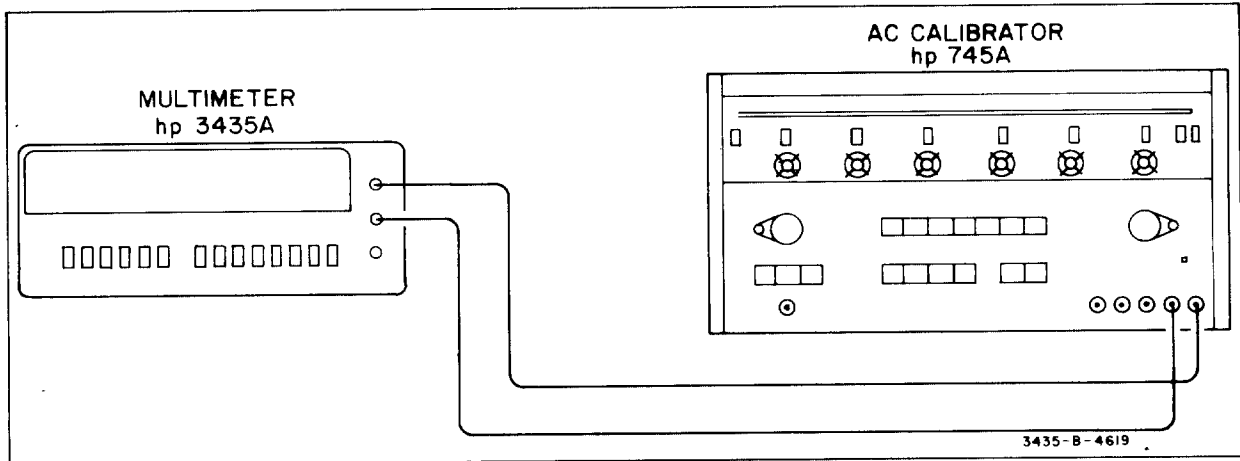

Figure 5-9. AC Gain Adjustment.

a. Set the 745A AC Calibrator as follows:

- Frequency 20 kHz
- Voltage range 10 V
- Output voltage 1.90000 V (ac)

b. Set the Multimeter to acV, 2 V range.

c. Connect the 745A to the Multimeter as shown in Figure 5-9.

d. Adjust R110 for a Multimeter display reading of 1.900 V.

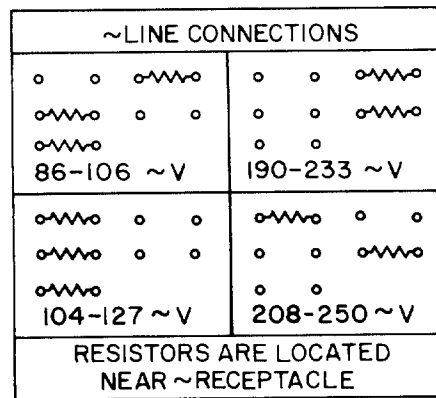
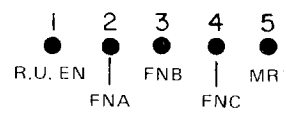
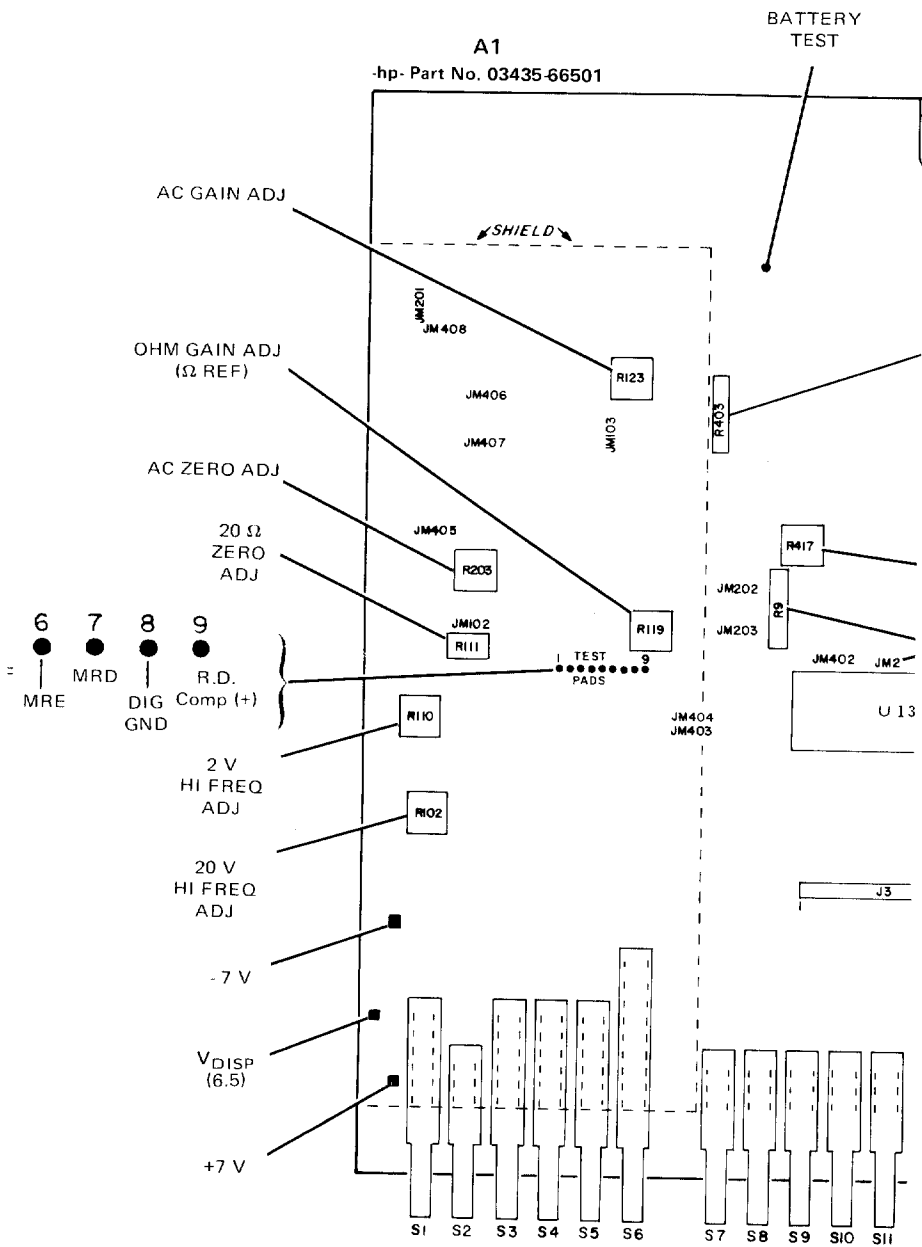
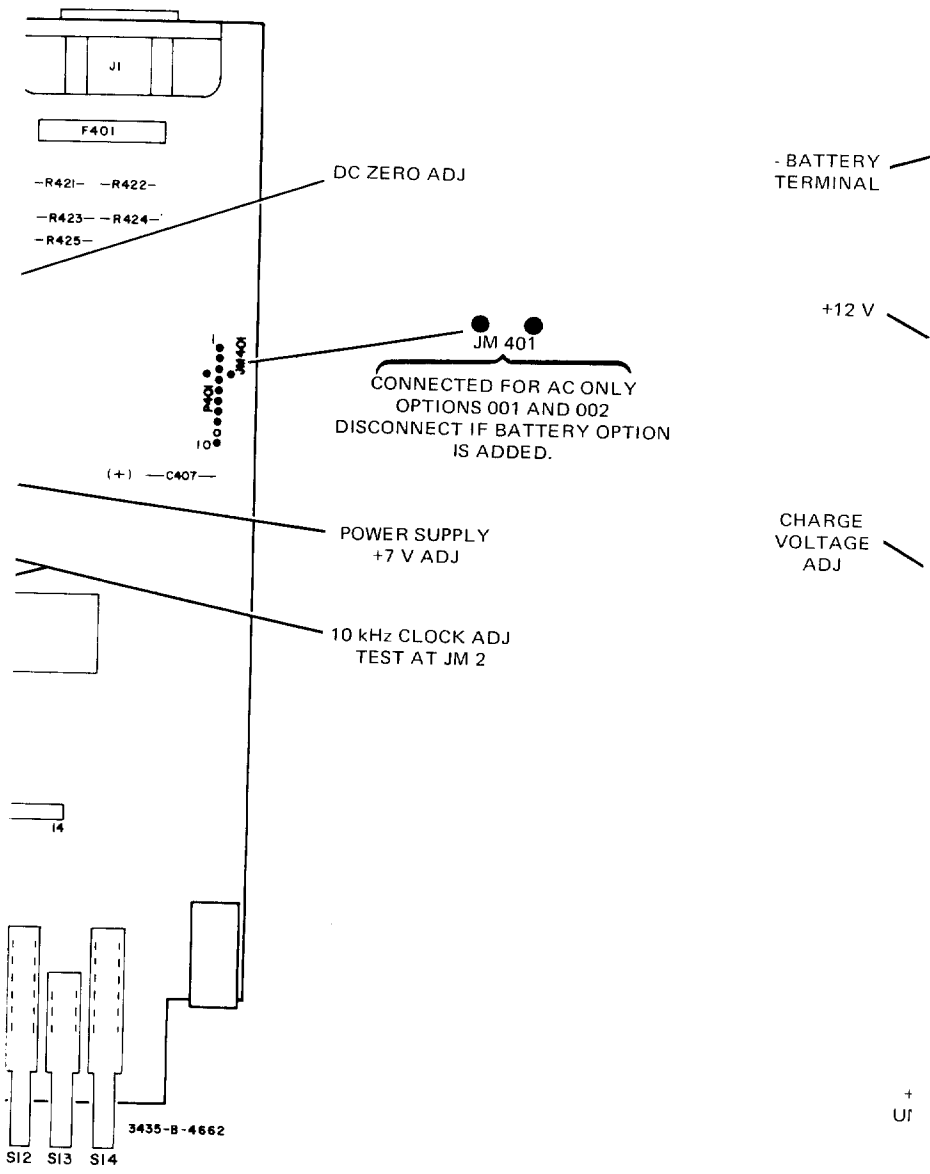

Figure 5-10. Line Voltage Configurations.







A3  
 -hp- Part No. 03435-66503

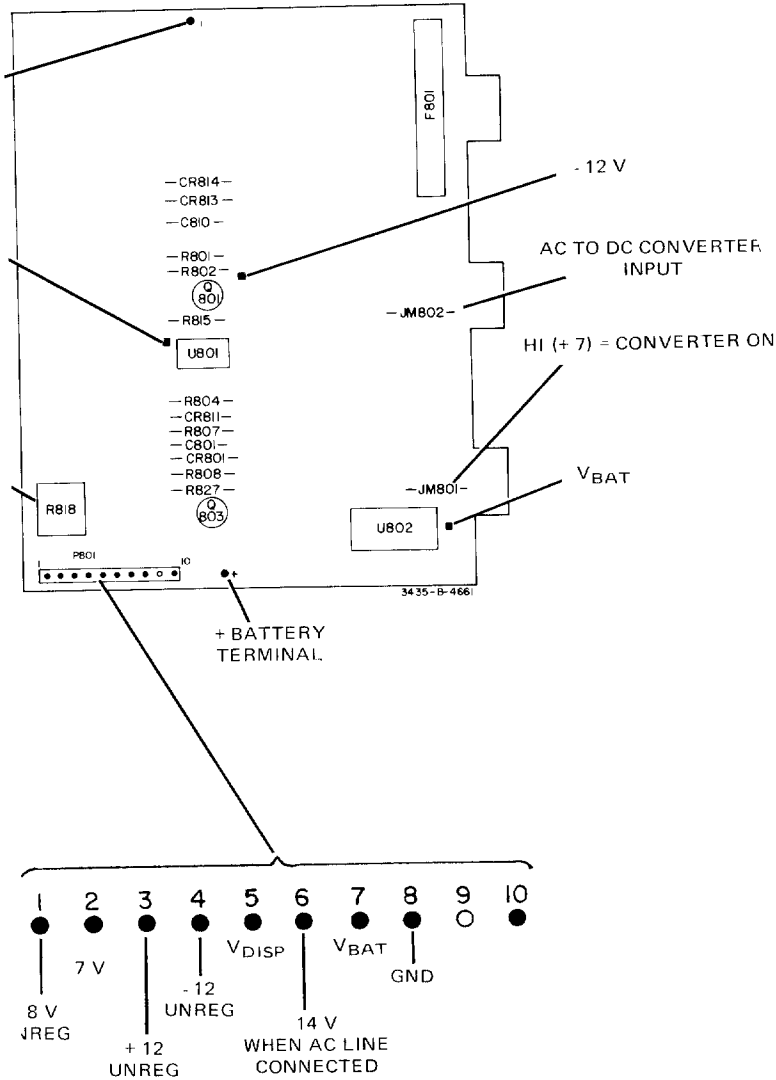

Figure 5-11. Adjustment Locator.  
 5-9/5-10

Multimeter

Date \_\_\_\_\_

Serial No. \_\_\_\_\_

**PERFORMANCE TEST CARD**

| Paragraph Number      | Test                   | Test Limit           | Test Result |
|-----------------------|------------------------|----------------------|-------------|
| 5-6                   | AC Voltage Accuracy    |                      |             |
|                       | 200 mV Range           |                      |             |
|                       | 10 mV   30 Hz          | 9.5 to 10.5 mV       | _____       |
|                       | 10 mV   50 Hz          | 9.7 to 10.3 mV       | _____       |
|                       | 10 mV   1 kHz          | 9.7 to 10.3 mV       | _____       |
|                       | 10 mV   10 kHz         | 9.7 to 10.3 mV       | _____       |
|                       | 10 mV   20 kHz         | 9.7 to 10.3 mV       | _____       |
|                       | 10 mV   50 kHz         | 8.8 to 11.2 mV       | _____       |
|                       | 10 mV   100 kHz        | 8.8 to 11.2 mV       | _____       |
|                       | 50 mV   30 Hz          | 49.0 to 51.1 mV      | _____       |
|                       | 50 mV   50 Hz          | 49.5 to 50.5 mV      | _____       |
|                       | 50 mV   20 kHz         | 49.5 to 50.5 mV      | _____       |
|                       | 50 mV   100 kHz        | 48.2 to 51.7 mV      | _____       |
|                       | 100 mV   30 Hz         | 98.2 to 101.8 mV     | _____       |
|                       | 100 mV   50 Hz, 500 Hz | 99.4 to 100.6 mV     | _____       |
|                       | 100 mV   20 kHz        | 99.4 to 100.6 mV     | _____       |
|                       | 100 mV   100 kHz       | 97.5 to 102.5 mV     | _____       |
|                       | 2 V Range              |                      |             |
|                       | 1 V   30 Hz            | .982 to 1.018 V      | _____       |
|                       | 1 V   50 Hz, 1 kHz     | .994 to 1.006 V      | _____       |
|                       | 1 V   20 kHz           | .994 to 1.006 V      | _____       |
|                       | 1 V   100 kHz          | .975 to 1.025 V      | _____       |
|                       | 20 V Range             |                      |             |
|                       | 10 V   30 Hz           | 9.82 to 10.18 V      | _____       |
|                       | 10 V   50 Hz, 10 kHz   | 9.94 to 10.06 V      | _____       |
|                       | 10 V   20 kHz          | 9.94 to 10.06 V      | _____       |
|                       | 10 V   100 kHz         | 9.75 to 10.25 V      | _____       |
|                       | 200 V Range            |                      |             |
|                       | 100 V   30 Hz          | 98.2 to 101.8 V      | _____       |
|                       | 100 V   50 Hz, 15 kHz  | 99.4 to 100.6 V      | _____       |
| 100 V   20 kHz        | 99.4 to 100.6 V        | _____                |             |
| 100 V   100 kHz       | 97.5 to 102.5 V        | _____                |             |
| 1200 V Range          |                        |                      |             |
| 1000 V   30 Hz        | 982 to 1018 V          | _____                |             |
| 1000 V   50 Hz, 1 kHz | 994 to 1006 V          | _____                |             |
| 1000 V   20 kHz       | 994 to 1006 V          | _____                |             |
| 5-8                   | DC Voltage Accuracy    |                      |             |
|                       | 200 mV Range           |                      |             |
|                       | + 10 mV                | + 9.8 to + 10.2 mV   | _____       |
|                       | + 50 mV                | + 49.7 to + 50.25 mV | _____       |
|                       | - 100 mV               | - 99.7 to - 100.3 mV | _____       |
|                       | 2 V Range              |                      |             |
|                       | - .1 V                 | - .099 to - .101 V   | _____       |
|                       | + .5 V                 | + .498 to + .502 V   | _____       |
|                       | + 1 V                  | + .998 to + 1.002 V  | _____       |
|                       | 20 V Range             |                      |             |
|                       | - 2 V                  | - 1.99 to - 2.01 V   | _____       |
|                       | - 5 V                  | - 4.98 to - 5.02 V   | _____       |
|                       | + 10 V                 | + 9.98 to + 10.02 V  | _____       |
|                       | 200 V Range            |                      |             |
|                       | + 20 V                 | +19.9 to + 20.1 V    | _____       |
| - 50 V                | - 49.8 to - 50.2 V     | _____                |             |
| - 100 V               | - 99.8 to - 100.2 V    | _____                |             |
| 1200 V Range          |                        |                      |             |
| + 200 V               | + 198 to + 201 V       | _____                |             |
| - 500 V               | - 498 to - 502 V       | _____                |             |
| + 1000 V              | + 998 to + 1002 V      | _____                |             |

**PERFORMANCE TEST CARD (CONT'd)**

| Paragraph Number | Test                | Test Limit               | Test Result                                |                |
|------------------|---------------------|--------------------------|--|----------------|
| 5-10             | AC Ammeter Accuracy |                          |  |                |
|                  | 200 $\mu$ A         |                          |  |                |
|                  | 10 $\mu$ A          | 30 Hz<br>50 Hz, 10 kHz   | 9.4 to 10.6 $\mu$ A<br>9.5 to 10.5 $\mu$ A | _____<br>_____ |
|                  | 2 mA                |                          |  |                |
|                  | .1 mA               | 30 Hz<br>50 Hz, 10 kHz   | .094 to .106 mA<br>.095 to .105 mA         | _____<br>_____ |
|                  | 20 mA               |                          |  |                |
|                  | 1 mA                | 30 Hz<br>50 Hz, 10 kHz   | .94 to 1.06 mA<br>.95 to 1.05 mA           | _____<br>_____ |
|                  | 200 mA              |                          |  |                |
|                  | 20 mA               | 60 Hz                    | 19.4 to 20.6 mA                            | _____          |
|                  | 50 mA               | 60 Hz                    | 49.1 to 50.9 mA                            | _____          |
|                  | 100 mA              | 60 Hz                    | 98.7 to 101.3 mA                           | _____          |
|                  | 2000 mA             |                          |  |                |
|                  | 100 mA              | 60 Hz                    | 95 to 105 mA                               | _____          |
|                  | 500 mA              | 60 Hz                    | 490 to 510 mA                              | _____          |
| 1000 mA          | 60 Hz               | 984 to 1016 mA           | _____                                      |                |
| 5-11             | DC Ammeter Accuracy |                          |  |                |
|                  | 200 $\mu$ A Range   |                          |  |                |
|                  | 10 $\mu$ A          |                          | 9.8 to 10.2 $\mu$ A                        | _____          |
|                  | 50 $\mu$ A          |                          | 49.6 to 50.4 $\mu$ A                       | _____          |
|                  | 100 $\mu$ A         |                          | 99.5 to 100.5 $\mu$ A                      | _____          |
|                  | 2 mA Range          |                          |  |                |
|                  | .1 mA               |                          | .098 to .102 mA                            | _____          |
|                  | .5 mA               |                          | .496 to .503 mA                            | _____          |
|                  | 1 mA                |                          | .995 to 1.005 mA                           | _____          |
|                  | 20 mA Range         |                          |  |                |
|                  | 1 mA                |                          | .98 to 1.02 mA                             | _____          |
|                  | 5 mA                |                          | 4.96 to 5.04 mA                            | _____          |
|                  | 10 mA               |                          | 9.95 to 10.05 mA                           | _____          |
|                  | 200 mA Range        |                          |  |                |
| 10 mA            |                     | 9.8 to 10.2 mA           | _____                                      |                |
| 50 mA            |                     | 49.6 to 50.4 mA          | _____                                      |                |
| 100 mA           |                     | 99.5 to 100.5 mA         | _____                                      |                |
| 2000 mA Range    |                     |                          |  |                |
| 100 mA           |                     | 97 to 103 mA             | _____                                      |                |
| 500 mA           |                     | 495 to 505 mA            | _____                                      |                |
| 1000 mA          |                     | 992 to 1008 mA           | _____                                      |                |
| 5-13             | Ohms Accuracy       |                          |  |                |
|                  | 20 $\Omega$ Range   |                          |  |                |
|                  | 1 $\Omega$          |                          | .89 to 1.11 $\Omega$                       | _____          |
|                  | 5 $\Omega$          |                          | 4.87 to 5.13 $\Omega$                      | _____          |
|                  | 10 $\Omega$         |                          | 9.85 to 10.15 $\Omega$                     | _____          |
|                  | 200 $\Omega$ Range  |                          |  |                |
|                  | 10 $\Omega$         |                          | 9.8 to 10.2 $\Omega$                       | _____          |
|                  | 50 $\Omega$         |                          | 49.7 to 50.3 $\Omega$                      | _____          |
|                  | 100 $\Omega$        |                          | 99.6 to 100.4 $\Omega$                     | _____          |
|                  | 2 k $\Omega$ Range  |                          |  |                |
|                  | 200 $\Omega$ (.2 k) |                          | .198 to .202 k $\Omega$                    | _____          |
|                  | 500 $\Omega$ (.5 k) |                          | .497 to .503 k $\Omega$                    | _____          |
|                  | 1 k $\Omega$        |                          | .996 to 1.004 k $\Omega$                   | _____          |
|                  | 20 k $\Omega$ Range |                          |  |                |
| 2 k $\Omega$     |                     | 1.98 to 2.02 k $\Omega$  | _____                                      |                |
| 5 k $\Omega$     |                     | 4.97 to 5.03 k $\Omega$  | _____                                      |                |
| 10 k $\Omega$    |                     | 9.96 to 10.04 k $\Omega$ | _____                                      |                |

**PERFORMANCE TEST CARD (CONT'd)**

| Paragraph Number | Test   | Test Limit  | Test Result   |
|------------------|--|---|---|
| 5-13<br>(Cont'd) | 200 k $\Omega$ Range<br>20 k $\Omega$<br>50 k $\Omega$<br>100 k $\Omega$<br><br>2000 k $\Omega$ Range<br>200 k $\Omega$<br>500 k $\Omega$<br>1000 k $\Omega$<br><br>20 M $\Omega$ Range<br>1 M $\Omega$<br>5 M $\Omega$<br>10 M $\Omega$ | 19.8 to 20.2 k $\Omega$<br>49.7 to 50.3 k $\Omega$<br>99.6 to 100.4 k $\Omega$<br><br>198 to 202 k $\Omega$<br>497 to 503 k $\Omega$<br>996 to 1004 k $\Omega$<br><br>.97 to 1.03 M $\Omega$<br>4.94 to 5.06 M $\Omega$<br>9.90 to 10.10 M $\Omega$ | _____<br>_____<br>_____<br><br>_____<br>_____<br>_____<br><br>_____<br>_____<br>_____ |
| 5-15             | AC Normal Mode Rejection at 50 and 60 Hz   | < 100 mV (40 dB)  | _____   |
| 5-17             | Effective Common Mode Rejection at 50 and 60 Hz  | < .1 mV (120 dB)  | _____   |



Table 6-2. Code List of Manufacturers.

| MFR NO. | MANUFACTURER'S CODE LIST                       | ADDRESS                 |
|---------|--|-------------------------|
| 00000   | U.S.A. COMMON                                  | ANY SUPPLIER OF USA     |
| 00160   | OHARA METAL PRODUCTS                           | SAN FRANCISCO CAL 94107 |
| 01121   | ALLEN BRADLEY CO.                              | MILWAUKEE WI 53212      |
| 01295   | TEXAS INSTRUMENT INC. SEMICONDUCTOR CMPNT DIV. | DALLAS TX 75231         |
| 01686   | RCL ELECTRONICS INC.                           | MANCHESTER NH 03102     |
| 02735   | RCA CORP. SOLID STATE DIV.                     | SOMMERVILLE NJ 08876    |
| 03888   | PYROFILM CORP.                                 | WHIPPANY NJ 07981       |
| 04713   | MOTOROLA SEMICONDUCTOR PRODUCTS                | PHOENIX AZ 85008        |
| 12954   | DICKSON ELECTRONICS CORP.                      | SCOTTSDALE AZ 85252     |
| 14140   | EDISON ELEK DIV MCGRAW-EDISON                  | MANCHESTER NH 03130     |
| 16299   | CORNING GLASS WORKS ELEC CMPNT DIV.            | RALEIGH NC 27604        |
| 17856   | SILICONIX INC.                                 | SANTA CLARA CA 95050    |
| 19701   | MEPCO/ELECTRA CORP.                            | MINERAL WELLS TX 76067  |
| 24546   | CORNING GLASS WORKS (BRADFORD)                 | BRADFORD PA 16701       |
| 27014   | NATIONAL SEMICONDUCTOR CORP.                   | SANTA CLARA CA 95051    |
| 28480   | HEWLETT-PACKARD CO. CORPORATE HQ               | PALO ALTO CA 94304      |
| 32997   | BOURNS INC TRIMPOT PROD DIV.                   | RIVERSIDE CA 92707      |
| 56289   | SPRAGUE ELECTRIC CO.                           | NORTH ADAMS MA 01247    |
| 71400   | BUSSMAN MFG DIV OF MCGRAW-EDISON CO.           | ST LOUIS MO 63017       |
| 72136   | ELECTRO MOTIVE MFG CO., INC.                   | WILLIMANTIC CT 06226    |
| 73138   | BECKMAN INSTRUMENTS INC HELIPOT DIV.           | FULLERTON CA 92634      |
| 74970   | JOHNSON E. F. CO.                              | WASECA MN 56093         |
| 84411   | TRW CAPACITOR DIV                              | OGALLALA NE 69153       |
| 91506   | AUGAT INC                                      | ATTLEBORO MA 02703      |
| 95121   | QUALITY COMPONENTS INC                         | ST MARYS PA 15857       |
| 98291   | SEAELECTRO CORP.                               | MAMARONECK NY 10544     |

Table 6-3 Replaceable Parts

| Reference Designation | HP Part Number | Qty | Description   | Mfr Code | Mfr Part Number    |
|-----------------------|----------------|-----|---|----------|--------------------|
| A1                    | 03435-66501    | 1   | MAIN PC ASSEMBLY  | 28480    | 03435-66501        |
| A1C1                  | 0150-0012      | 4   | CAPACITOR-FXD .01UF +-20% 1000WVDC CER                  | 56289    | C023A102J103MS38   |
| A1C2                  | 0160-2384      | 1   | CAPACITOR-FXD 120PF +-5% 500 WVDC MICA                  | 28480    | 0160-2384          |
| A1C3                  | 0160-0378      | 1   | CAPACITOR-FXD 27PF +-5% 500WVDC MICA                    | 28480    | 0160-0378          |
| A1C99                 | 0150-0014      | 1   | CAPACITOR-FXD 5000PF -100-0% 500WVDC CER                | 28480    | 0150-0014          |
| A1C100                | 0150-0012      | 4   | CAPACITOR-FXD .01UF +-20% 1000WVDC CER                  | 56289    | C023A102J103MS38   |
| A1C101                | 0150-0012      | 4   | CAPACITOR-FXD .01UF +-20% 1000WVDC CER                  | 56289    | C023A102J103MS38   |
| A1C102                | 0160-4418      | 1   | CAPACITOR-FXD 22 PF +-5% 500WVDC                        | 28480    | 0160-4418          |
| A1C103                | 0160-0336      | 2   | CAPACITOR-FXD 100PF +-1% 300WVDC MICA                   | 28480    | 0160-0336          |
| A1C104                | 0140-0234      | 1   | CAPACITOR-FXD 500PF +-1% 300WVDC MICA                   | 72136    | DM15F50TF0300WV1C  |
| A1C105                | 0160-0336      | 2   | CAPACITOR-FXD 100PF +-1% 300WVDC MICA                   | 28480    | 0160-0336          |
| A1C106                | 0160-2197      | 2   | CAPACITOR-FXD 10PF +-5% 300WVDC MICA                    | 28480    | 0160-2197          |
| A1C107                | 0160-0153      | 1   | CAPACITOR-FXD 1000PF +-10% 200WVDC                      | 56289    | 292P10292          |
| A1C108                | 0160-3847      | 6   | CAPACITOR-FXD .01UF +100-0% 25WVDC CER                  | 28480    | 0160-3847          |
| A1C109                | 0150-0059      | 1   | CAPACITOR-FXD 3.3PF +-25PF 500 WVDC CER                 | 28480    | 0150-0059          |
| A1C110                | 0160-2197      | 2   | CAPACITOR-FXD 10PF +-5% 300WVDC MICA                    | 28480    | 0160-2197          |
| A1C111                | 0140-0145      | 1   | CAPACITOR-FXD 22PF +-5% 500WVDC MICA                    | 72136    | DM15C220J0500WV1CR |
| A1C112                | 0180-0291      | 6   | CAPACITOR-FXD 1UF +-10% 35VDC TA                        | 56289    | 150D105X9035A2     |
| A1C113                | 0180-0291      | 1   | CAPACITOR-FXD 1UF +-10% 35VDC TA                        | 56289    | 150D105X9035A2     |
| A1C114                | 0180-0291      | 6   | CAPACITOR-FXD 1UF +-10% 35VDC TA                        | 56289    | 150D105X9035A2     |
| A1C115                | 0150-0044      | 4   | CAPACITOR-FXD 5.6PF +-5% 500WVDC TI                     | 95121    | TYPE OC            |
| A1C116                | 0150-0044      | 4   | CAPACITOR-FXD 5.6PF +-5% 500WVDC TI                     | 95121    | TYPE OC            |
| A1C117                | 0160-3847      | 6   | CAPACITOR-FXD .01UF +100-0% 25WVDC CER                  | 28480    | 0160-3847          |
| A1C118                | 0160-3847      | 6   | CAPACITOR-FXD .01UF +100-0% 25WVDC CER                  | 28480    | 0160-3847          |
| A1C119                | 0180-0291      | 6   | CAPACITOR-FXD 1UF +-10% 35VDC TA                        | 56289    | 150D105X9035A2     |
| A1C120                | 0180-0116      | 1   | CAPACITOR-FXD 6.8UF +-10% 35VDC TA                      | 56289    | 150D685X9035B2     |
| A1C121                | 0150-0012      | 4   | CAPACITOR-FXD .01UF +-20% 1000WVDC CER                  | 56249    | C023A102J103MS38   |
| A1C202                | 0160-0168      | 1   | CAPACITOR-FXD .1UF +-10% 200WVDC                        | 56289    | 292P10492          |
| A1C203                | 0150-0044      | 4   | CAPACITOR-FXD 5.6PF +-5% 500WVDC TI                     | 95121    | TYPE OC            |
| A1C204                | 0150-0044      | 4   | CAPACITOR-FXD 5.6PF +-5% 500WVDC TI                     | 95121    | TYPE OC            |
| A1C205                | 0170-0038      | 1   | CAPACITOR-FXD .22UF +-10% 200WVDC                       | 28480    | 0170-0038          |
| A1C400                | 0160-2055      | 1   | CAPACITOR-FXD .01UF +80 20% 100WVDC CER                 | 28480    | 0160-2055          |
| A1C401                | 0180-2851      | 1   | CAPACITOR-FXD 470UF +75 -10% 16VDC AL                   | 56289    | 500D447H016DF7     |
| A1C402                | 0160-3847      | 5   | CAPACITOR-FXD .01UF +100-0% 25WVDC CER                  | 28480    | 0160-3847          |
| A1C403                | 0180-2638      | 2   | CAPACITOR-FXD 220UF +75 -10% 35VDC AL                   | 56289    | 500D227H035DF7     |
| A1C404                | 0180-3847      | 5   | CAPACITOR-FXD .01UF 25V                                 | 28480    | 0180-3847          |
| A1C405                | 0180-2638      | 2   | CAPACITOR-FXD 220UF -75 -10% 35VDC AL                   | 56289    | 500D227H035DF7     |
| A1C406                | 0140-0198      | 1   | CAPACITOR-FXD 200PF +-5% 300WVDC MICA                   | 72136    | DM15F201J0300WV1CR |
| A1C407                | 0180-0291      | 6   | CAPACITOR-FXD 1UF +-10% 35VDC TA                        | 56289    | 150D105X9035A2     |
| A1C408                | 0160-0362      | 2   | CAPACITOR-FXD 510PF +-5% 300WVDC MICA                   | 28480    | 0160-0362          |
| A1C409                | 0180-0291      | 6   | CAPACITOR-FXD 1UF +-10% 35VDC TA                        | 56289    | 150D105X9035A2     |
| A1C410                | 0180-0228      | 1   | CAPACITOR-FXD 22UF +-10% 15VDC TA                       | 56289    | 150D226X9015B2     |
| A1CR1                 | 1901-0040      | 8   | DIODE-SWITCHING 30V 50MA 2NS DO-35                      | 28480    | 1901-0040          |
| A1CR100               | 1906-0023      | 1   | DIODE-MULTI FULL WAVE BRIDGE RECTIFIER                  | 04713    | MDA922-4           |
| A1CR101               | 1901-0376      | 2   | DIODE-GEN PRP 35V 50MA DO-7                             | 28480    | 1901-0376          |
| A1CR102               | 1901-0376      | 2   | DIODE-GEN PRP 35V 50MA DO-7                             | 28480    | 1901-0376          |
| A1CR103               | 1901-0040      | 8   | DIODE-SWITCHING 50V 500MA 30NS DO-7                     | 28480    | 1901-0040          |
| A1CR104               | 1901-0040      | 8   | DIODE-SWITCHING 50V 500MA 30NS DO-7                     | 28480    | 1901-0040          |
| A1CR105               | 1901-0029      | 3   | DIODE-PRW RECT 600V 750MA DO-29                         | 28480    | 1901-0029          |
| A1CR107               | 1901-0040      | 8   | DIODE-SWITCHING 50V 500MA 30NS DO-7                     | 28480    | 1901-0040          |
| A1CR108               | 1902-0554      | 1   | DIODE-ZNR 10V 5% DO-15 PD-IN TC=+.06%                   | 28480    | 1902-0554          |
| A1CR110               | 1901-0535      | 2   | DIODE-SCHOTTKY  | 28480    | 1901-0535          |
| A1CR111               | 1901-0535      | 2   | DIODE-SCHOTTKY  | 28480    | 1901-0535          |
| A1CR200               | 1901-0040      | 8   | DIODE-SWITCHING 50V 500MA 30NS DO-7                     | 28480    | 1901-0040          |
| A1CR201               | 1901-0040      | 8   | DIODE-SWITCHING 50V 500MA 30NS DO-7                     | 28480    | 1901-0040          |
| A1CR202               | 1901-0040      | 8   | DIODE-SWITCHING 50V 500MA 30NS DO-7                     | 28480    | 1901-0040          |
| A1CR203               | 1901-0040      | 8   | DIODE-SWITCHING 50V 500MA 30NS DO-7                     | 28480    | 1901-0040          |
| A1CR400               | 1902-1329      | 1   | DIODE-ZENER 6.95V                                       | 28480    | 1902-1329          |
| A1CR401               | 1901-0029      | 3   | DIODE-PRW RECT 600V 750MA DO-29                         | 28480    | 1901-0029          |
| A1CR402               | 1901-0029      | 3   | DIODE-PRW RECT 600V 750MA DO-29                         | 28480    | 1901-0029          |
| A1CR403               | 1901-0050      | 6   | DIODE-SWITCHING 80V 200MA 2NS DO-7                      | 28480    | 1901-0050          |
| A1CR404 - 408         | 1901-0050      | 6   | DIODE-SWITCHING 80V 200MA 2NS DO-7                      | 28480    | 1901-0050          |
| A1F401                | 2110-0318      | 1   | FUSE-.125A 250V SLOW-BLO 1.25 x .25                     | 08806    | A1H                |
| A1J1                  | 5040-8013      | 1   | AC POWER RECEPTACLE                                     | 28480    | 5040-8013          |
| A1J3                  | 1251-4390      | 2   | 14 PIN DISPLAY CONNECTOR, FEMALE                        | 28480    | 1251-4390          |
| A1J401                | 03435-61601    | 2   | CABLE ASSEMBLY W/CONNECTORS, P/O AIW2                   | 28480    | 03435-61601        |
| A1P401                | 1251-4401      | 3   | 10 PIN BATTERY CHARGER CONNECTOR, M (PIN 9 CLIPPED OUT) | 27264    | 22-04-2101         |
| A1Q1, Q2              | 1854-0071      | 5   | TRANSISTOR-NPN SI PD=300MW FT=200MHZ                    | 28480    | 1854-0071          |
| A1Q3 - Q6             | 1853-0016      | 4   | TRANSISTOR-PNP SI TO-92 PD=300MW                        | 28480    | 1853-0016          |
| A1Q17, Q18            | 1854-0071      | 5   | TRANSISTOR-NPN SI PD=300MW FT=200MHZ                    | 28480    | 1854-0071          |
| A1Q101                | 1854-0079      | 1   | TRANSISTOR-NPN 2N3439 SI                                | 02735    | 2N3439             |
| A1Q401                | 1854-0071      | 5   | TRANSISTOR-NPN SI PD=300MW FT=200MHZ                    | 28480    | 1854-0071          |
| A1Q402                | 1854-0039      | 1   | TRANSISTOR-NPN 2N3053 SI                                | 04713    | 2N3053             |
| A1Q403                | 1853-0012      | 1   | TRANSISTOR-PNP 2N2904A SI                               | 01295    | 2N2904A            |

Table 6-3 Replaceable Parts(Cont'd)

| Reference Designation | HP Part Number | Qty | Description                    | Mfr Code | Mfr Part Number     |
|-----------------------|----------------|-----|--------------------------------|----------|---------------------|
| A1R1, R2              | 0698-8767      | 3   | RESISTOR-FXD 200K OHM .5       | 28480    | 0698-8767           |
| A1R3, R4              | 0683-4735      | 2   | RESISTOR-FXD 47K 5% .25W       | 01121    | CB4735              |
| A1R5 - R7             | 0683-1025      | 4   | RESISTOR-1K 5% .25W            | 01121    | CB1025              |
| A1R8                  | 0698-4519      | 1   | RESISTOR-140K 1% .125W         | 24546    | C4-1/8-TO-1403-F    |
| A1R9                  | 2100-3094      | 1   | RESISTOR-TRMR 100K 10%         | 32997    | 3006P-1-104         |
| A1R10 - R13           | 0683-5115      | 4   | RESISTOR-510 5% .25W           | 01121    | CB5115              |
| A1R14 - R17           | 0683-2035      | 4   | RESISTOR-20K 5% .25W           | 01121    | CB2035              |
| A1R20                 | 0757-0437      | 4   | RESISTOR-4.75K 1% .125W        | 24546    | C4-1/8-TO-4751-F    |
| A1R100                | 0698-8717      | 1   | RESISTOR-4.78M 1% 1W           | 07716    | CEC-993-N330        |
| A1R101                | 0757-0437      | 3   | RESISTOR-4.75K 1% .125W        | 24546    | C4-1/8-TO-4751-F    |
| A1R102                | 2100-0558      | 1   | RESISTOR-TRMR 20K 10%          | 32997    | 3386P-Y46-203       |
| A1R103                | 0698-8716      | 1   | RESISTOR-8M 5% 2W              | 07716    | CCF-993-N330        |
| A1R106                | 0683-1065      | 1   | RESISTOR-10M 5% .25W           | 01121    | CB 1065             |
| A1R107                | 0683-0275      | 2   | RESISTOR-2.7 5% .25W           | 01121    | CB27G5              |
| A1R108                | 0698-4123      | 6   | RESISTOR-FXD 499 OHM 1% .125W  | 16299    | C4-1/8-TO-499R-F    |
| A1R109                | 0698-4202      | 1   | RESISTOR-8.87K 1% .125W        | 16299    | C4-1/8-TO-8871-F    |
| A1R110                | 2100-3211      | 1   | RESISTOR-TRMR 1K 10%           | 32997    | 3386P-Y46-102       |
| A1R111                | 2100-3566      | 1   | RESISTOR-V 100K                | 28480    | 2100-3566           |
| A1R112                | 0757-0472      | 4   | RESISTOR-200K 1% .125W         | 24546    | C4-1/8-TO-2003-F    |
| A1R113                | 0757-0410      | 2   | RESISTOR-301 1% .125W          | 24546    | C4-1/8-TO-301R-F    |
| A1R114                | 0757-0473      | 2   | RESISTOR-221K 1% .125W         | 24546    | C4-1/8-TO-2213-F    |
| A1R115                | 0698-3159      | 2   | RESISTOR-26.1K 1% .125W        | 16299    | C4-1/8-TO-2612-F    |
| A1R116                | 0698-8767      | 3   | RESISTOR-FXD 200K OHM .5       | 28480    | 0698-8767           |
| A1R117                | 0757-0437      | 3   | RESISTOR-4.75K 1% .125W        | 24546    | C4-1/8-TO-4751-F    |
| A1R118                | 0698-8768      | 3   | RESISTOR-FXD 100 OHM .5        | 28480    | 0698-8768           |
| A1R119                | 2100-3210      | 3   | RESISTOR-TRMR 10K 10%          | 32997    | 3386P-Y46-103       |
| A1R120                | 0698-4485      | 1   | RESISTOR-23.2K 1% .125W        | 24546    | C4-1/8-TO-2322-F    |
| A1R121                | 0757-0449      | 4   | RESISTOR-20K 1% .125W          | 24546    | C4-1/8-TO-2002-F    |
| A1R122                | 0698-3160      | 1   | RESISTOR-31.6K 1% .125W        | 16299    | C4-1/8-TO-3162-F    |
| A1R123                | 2100-3210      | 3   | RESISTOR-TRMR 10K 10%          | 32997    | 3386P-Y46-103       |
| A1R124                | 0757-0461      | 1   | RESISTOR-68.1K 1% .125W        | 24546    | C4-1/8-TO-6812-F    |
| A1R125                | 0757-0473      | 2   | RESISTOR-221K 1% .125W         | 24546    | C4-1/8-TO-2213-F    |
| A1R126                | 0683-1065      | 1   | RESISTOR-1M 5% .25W            | 01121    | CB1055              |
| A1R127, R128          | 0757-0465      | 2   | RESISTOR-100K 1% .125W         | 24546    | C4-1/8-TO-1003-F    |
| A1R129, R130          | 0757-0442      | 4   | RESISTOR-10K 1% .125W          | 24546    | C4-1/8-TO-1002-F    |
| A1R131                | 0698-8768      | 3   | RESISTOR-FXD 100 OHM .5        | 28480    | 0698-8768           |
| A1R132                | 0757-0442      | 4   | RESISTOR-10K 1% .125W          | 24546    | C4-1/8-TO-1002-F    |
| A1R201                | 0757-0410      | 2   | RESISTOR-301 1% .125W          | 24546    | C4-1/8-TO-301R-F    |
| A1R202                | 0757-0472      | 4   | RESISTOR-200K 1% .125W         | 24546    | C4-1/8-TO-2003-F    |
| A1R203                | 2100-3214      | 1   | RESISTOR-TRMR 100K 10%         | 32997    | 3386P-Y46-104       |
| A1R204                | 0698-4123      | 2   | RESISTOR-499 1% .125W          | 16299    | C4-1/8-TO-499R-F    |
| A1R205                | 0757-0472      | 4   | RESISTOR-200K 1% .125W         | 24546    | C4-1/8-TO-2003-F    |
| A1R206                | 0683-1025      | 4   | RESISTOR-1K 5% .25W            | 01121    | CB1025              |
| A1R207                | 0757-0472      | 4   | RESISTOR-200K 1% .125W         | 24546    | C4-1/8-TO-2003-F    |
| A1R208                | 0757-0449      | 4   | RESISTOR-20K 1% .125W          | 24546    | C4-1/8-TO-2002-F    |
| A1R209                | 0757-0270      | 1   | RESISTOR-249K 1% .125W         | 24546    | C4-1/8-TO-2493-F    |
| A1R210                | 0698-8769      | 1   | RESISTOR FXD 49.7K .1%         | 28480    | 0698-8769           |
| A1R211                | 0698-8396      | 1   | RESISTOR-500K .1% .25W         | 19701    | MF52C14-T2-5003-B   |
| A1R401                | 0698-4472      | 1   | RESISTOR-7.68K 1% .125W        | 24546    | C4-1/8-TO-7681-F    |
| A1R402                | 0698-6481      | 1   | RESISTOR-16.2K 1% .125W        | 24546    | NE55                |
| A1R403                | 2100-3056      | 1   | RESISTOR-TRMR 5K 10%           | 32997    | 3006P-1-502         |
| A1R404                | 0698-7646      | 1   | RESISTOR-31.6K 1% .125W        | 19701    | MF4C1/8-T9-3162-F   |
| A1R405                | 0698-3540      | 1   | RESISTOR-15.4K 1% .125W        | 16299    | C4-1/8-TO-1542-F    |
| A1R406                | 0757-0459      | 2   | RESISTOR-56.2K 1% .125W        | 24546    | C4-1/8-TO-5622-F    |
| A1R407                | 0698-3159      | 1   | RESISTOR-26.1K 1% .125W        | 16299    | C4-1/8-TO-2612-F    |
| A1R408                | 0698-8768      | 3   | RESISTOR-FXD 100 OHM .5        | 28480    | 0698-8768           |
| A1R409                | 0757-0442      | 4   | RESISTOR-10K 1% .125W          | 24546    | C4-1/8-TO-1002-F    |
| A1R410                | 0698-3332      | 1   | RESISTOR-80.6 1% .5W           | 24546    | NA6                 |
| A1R411, R412          | 0757-0449      | 4   | RESISTOR-20K 1% .125W          | 24546    | C4-1/8-TO-2002-F    |
| A1R413                | 0698-4842      | 1   | RESISTOR-124 1% .5W            | 24546    | NA6                 |
| A1R414                | 0757-0437      | 3   | RESISTOR-4.75K 1% .125W        | 24546    | C4-1/8-TO-4751-F    |
| A1R415                | 0757-0283      | 1   | RESISTOR-2K 1% .125W           | 24546    | C4-1/8-TO-2001-F    |
| A1R416                | 0757-0458      | 1   | RESISTOR 51.1K 1% .125W        | 24546    | C4-1/8-TO-5112-F    |
| A1R417                | 2100-3210      | 3   | RESISTOR-TRMR 10K 10%          | 32997    | 3386P-Y46-103       |
| A1R418                | 0698-4502      | 1   | RESISTOR-64.9K 1% .125W        | 24546    | C4-1/8-TO-6492-F    |
| A1R419                | 0698-3279      | 1   | RESISTOR-4.99K 1% .125W        | 16299    | C4-1/8-TO-4991-F    |
| A1R421 - R425 *       | 0683-0275      | 6   | RESISTOR-2.7 5% .25W           | 01121    | CB27G5              |
| A1R501                | 0698-5453      | 1   | RESISTOR-900 OHM .1% .125W     | 03888    | PME55-1/8-T2-900R-B |
| A1R502                | 0698-5456      | 1   | RESISTOR-90 OHM .1% .125W      | 24546    | NC55                |
| A1R503                | 0811-3433      | 1   | RESISTOR-9 OHM .1% 3W          | 01686    | T2B-79              |
| A1R504                | 0811-3455      | 1   | RESISTOR-FXD .9 OHM .1% 4W     | 28480    | 0811-3455           |
| A1R505                | 0811-3435      | 1   | RESISTOR-.1 OHM .1%            | 01686    | T2B-79              |
| A1S1                  | 3101-2129      | 1   | PUSHBUTTON SWITCH, (PUSH PUSH) |          |                     |
| A1S2                  | 3101-2130      | 7   | PUSHBUTTON SWITCH              |          |                     |
| A1S3 - S5             | 3101-2128      | 5   | PUSHBUTTON SWITCH              |          |                     |
| A1S6                  | 3101-2127      | 1   | PUSHBUTTON SWITCH              |          |                     |
| A1S7-S11              | 3101-2130      | 7   | PUSHBUTTON SWITCH              |          |                     |
| A1S12, S14            | 3101-2128      | 5   | PUSHBUTTON SWITCH              |          |                     |
| A1S13                 | 3101-2130      | 7   | PUSHBUTTON SWITCH              |          |                     |

\* A jumper (short) may be substituted for R421 through R425.

Table 6-3 Replaceable Parts(Cont'd)

| Reference Designation | HP Part Number | Qty | Description                                  | Mfr Code | Mfr Part Number    |
|-----------------------|----------------|-----|--|----------|--------------------|
| A1T401                | 9100-3494      | 1   | TRANSFORMER                                  | 28480    | 9100-3494          |
| A1U1                  | 1826-0340      | 1   | OPERATIONAL AMPLIFIER LF356                  | 28480    | 1826-0340          |
| A1U2                  | 1826-0043      | 4   | IC LM 307 OP AMP                             | 27014    | LM307H             |
| A1U3 - U6             | 1820-0223      | 4   | IC LM 301A OP AMP                            | 27014    | LM301AH            |
| A1U7 - U9             | 1826-0043      | 4   | IC LM 307 OP AMP                             | 27014    | LM307H             |
| A1U10                 | 1826-0010      | 1   | IC UA 723 V RGL TR                           | 07263    | 723HM              |
| A1U11                 | 1813-0070      | 1   | INPUT HYBRID                                 | 28480    | 1813-0070          |
| A1U12                 | 1813-0071      | 1   | INTEGR HYBRID                                | 28480    | 1813-0071          |
| A1U13                 | 1820-1742      | 1   | CONTROL CHIP                                 | 28480    | 1820-1742          |
| A1U14, U15            | 1820-1231      | 2   | IC - DIGITAL SN75492N                        | 01295    | SN75492N           |
| A1W2                  | 03435-61601    | 1   | BATTERY CABLE W/CONNECTORS                   | 28480    | 03435-61603        |
| A1W3                  | 8120-3455      | 1   | RIBBON CABLE, 14 LEAD                        | 28480    | 8120-3455          |
| A2                    | 03435-66502    |     | DISPLAY PC ASSEMBLY                          | 28480    | 03435-66502        |
| A2DS1 - DS7           | 1990-0404      | 7   | LED VISIBLE - ANNUNCIATORS                   | 28480    | 1990-0404          |
| A2DSM1                | 1990-0532      | 1   | DISPLAY-NUM SEG 5 (+ - 1)                    | 28480    | 1990-0532          |
| A2DSM2 - DSM4         | 1990-0531      | 3   | DISPLAY-NUM SEG 1                            | 28480    | 1990-0531          |
| A2J1                  | 1251-4390      | 2   | 14 PIN CONNECTOR, FEMALE                     | 28480    | 1251-4390          |
| A2R1, R2              | 0683-1115      | 14  | RESISTOR-110 5% .25W                         | 01121    | CB1115             |
| A2R3                  | 0683-2215      | 3   | RESISTOR-220 5% .25W                         | 01121    | CB2215             |
| A2R4 - R8             | 0683-1115      | 14  | RESISTOR-110 5% .25W                         | 01121    | CB1115             |
| A2R9, R10             | 0683-2215      | 3   | RESISTOR-220 5% .25W                         | 01121    | CB2215             |
| A2R19 - R25           | 0683-1115      | 14  | RESISTOR-110 5% .25W                         | 01121    | CB1115             |
| W3                    | 8120-2279      | 1   | CABLE-UNSHLD 26 AWG 14-CNDCT                 | 28480    | 8120-2279          |
| A3                    | 03435-66503    |     | BATTERY CHARGER PC ASSEMBLY                  | 28480    | 03435-66503        |
| BT801                 | 1420-0233      | 1   | 6 VOLT BATTERY PACK                          | 28480    | 1420-0233          |
| A3C801, C802          | 0160-3847      | 4   | CAPACITOR-FXD .01UF +100-0% 25WVDC CER       | 28480    | 0160-3847          |
| A3C803                | 0180-1743      | 1   | CAPACITOR-FXD .1UF +-10% 35VDC TA            | 56289    | 150D104X9035A2     |
| A3C805                | 0150-0084      | 1   | CAPACITOR-FXD .1UF +80-20% 100WVDC CER       | 28480    | 0150-0084          |
| A3C806                | 0160-2204      | 1   | CAPACITOR-FXD 100PF +-5% 300WVDC MICA        | 09023    | RD015F101J3C       |
| A3C807                | 0140-0195      | 1   | CAPACITOR-FXD 130PF +-5% 300WVDC MICA        | 72136    | DM15F131J0300WV1CR |
| A3C808                | 0180-0309      | 1   | CAPACITOR-FXD 4.7UF +-20% 10VDC TA           | 56289    | 150D475X0010A2     |
| A3C809, C810          | 0160-3847      | 4   | CAPACITOR-FXD .01UF -100-0% 25WVDC CER       | 28480    | 0160-3847          |
| A3CR801               | 1901-0040      | 9   | DIODE-SWITCHING 30V 50MA 2NS                 | 28480    | 1901-0040          |
| A3CR802               | 1902-3182      | 1   | DIODE-ZNR 12.1V 5%                           | 04713    | SZ 10939-206       |
| A3CR804 - CR811       | 1901-0040      | 9   | DIODE-SWITCHING 30V 50MA 2NS                 | 28480    | 1901-0040          |
| A3CR812 - CR815       | 1910-0034      | 4   | DIODE-GE 30V 80MA 8NS                        | 28480    | 1910-0034          |
| A3CR816, CR817        | 1901-0535      | 2   | DIODE-HOT CARRIER                            | 28480    | 1901-0535          |
| A3F801                | 2110-0002      | 1   | FUSE 2A 250V FAST-BLO                        | 71400    | AGC-2              |
| A3J801                | 03435-61601    | 1   | BATTERY CABLE W/CONNECTOR, P/O W2            | 28480    | 03435-61601        |
| A3P801                | 1251-4401      | 1   | 10 PIN MALE CONNECTOR<br>(PIN 9 CLIPPED OUT) | 27264    | 22-04-2101         |
| A3Q801                | 1853-0010      | 1   | TRANSISTOR-PNP SI TO-18                      | 28480    | 1853-0010          |
| A3Q802                | 1854-0063      | 1   | TRANSISTOR-NPN 2N3055 SI TO-3                | 28480    | 1854-0063          |
| A3Q803 - Q805         | 1854-0087      | 3   | TRANSISTOR-NPN SI PD=360MW                   | 28480    | 1854-0087          |
| A3R801                | 0683-3335      | 3   | RESISTOR-33K 5% .25W                         | 01121    | CB3335             |
| A3R802                | 0683-1515      | 1   | RESISTOR-150 5% .25W                         | 01121    | CB1515             |
| A3R803                | 0683-3325      | 3   | RESISTOR-3.3K 5% .25W                        | 01121    | CB3325             |
| A3R804                | 0757-0465      | 1   | RESISTOR-100K 1% .125W                       | 24546    | C4-1/8-TO-1003-F   |
| A3R805                | 0698-4508      | 1   | RESISTOR-78.7K 1% .125W                      | 24546    | C4-1/8-TO-7872-F   |
| A3R806                | 0698-3148      | 1   | RESISTOR-102K 1% .125W                       | 16299    | C4-1/8-TO-1023-F   |
| A3R807                | 0698-4518      | 1   | RESISTOR-137K 1% .125W                       | 24546    | C4-1/8-TO-1373-F   |
| A3R808                | 0698-1045      | 3   | RESISTOR-FXD 100K .05 1/4                    | 28480    | 0698-1045          |
| A3R809                | 0757-0479      | 2   | RESISTOR-392K 1% .125W                       | 19701    | MF4C1/8-TO-3923-F  |
| A3R810                | 0698-4431      | 1   | RESISTOR-2.05K 1% .125W                      | 16299    | C4-1/8-TO-2051-F   |
| A3R811                | 0812-0040      | 1   | RESISTOR-.27 5% 5W                           | 75042    | BW20-1/2-27/100-J  |
| A3R812                | 0683-1045      | 3   | RESISTOR-100K 5% .25W                        | 01121    | CB1045             |
| A3R813                | 0698-3279      | 1   | RESISTOR-4.99K 1% .125W                      | 16299    | C4-1/8-TO-4991-F   |
| A3R814                | 0698-3149      | 1   | RESISTOR-255K 1% .125W                       | 16299    | C4-1/8-TO-2553-F   |
| A3R815                | 0698-4531      | 1   | RESISTOR-267K 1% .125W                       | 24546    | C4-1/8-TO-2673-F   |
| A3R816, R817          | 0683-1055      | 2   | RESISTOR-1M 5% .25W                          | 01121    | CB1055             |
| A3R818                | 2100-0558      | 1   | RESISTOR-TRMR 20K 10%                        | 32997    | 3386F-Y46-203      |
| A3R819                | 0683-4755      | 1   | RESISTOR-4.7M 5% .25W                        | 01121    | CB4755             |
| A3R820                | 0757-0479      | 2   | RESISTOR-392K 1% .125W                       | 19701    | MF4C1/8-TO-3923-F  |
| A3R821, R822          | 0683-3335      | 3   | RESISTOR-33K 5% .25W                         | 01121    | CB3335             |
| A3R823                | 0683-1045      | 3   | RESISTOR-100K 5% .25W                        | 01121    | CB1045             |
| A3R824, R825          | 0683-3325      | 3   | RESISTOR-3.3K 5% .25W                        | 01121    | CB3325             |
| A3R826                | 0683-1005      | 1   | RESISTOR-10 5% .25W                          | 01121    | CB1005             |
| A3R827                | 0698-3268      | 1   | RESISTOR-11.5K 1% .125W                      | 16299    | C4-1/8-TO-1152-F   |
| A3T801                | 9100-3920      | 1   | PULSE TRANSFORMER                            | 28480    | 9100-0681          |
| A3U801                | 1826-0139      | 1   | IC MC 1458 OP AMP                            | 04713    | MC1458P1           |
| A3U802                | 1820-0944      | 1   | IC-DIGITAL CD4025AE CMOS                     | 02735    | CD4025AY           |
| A3U803                | 1820-0938      | 1   | IC-DIGITAL CD4027AE CMOS                     | 02735    | CD4027AY           |
| A3U804                | 1820-0949      | 1   | IC-DIGITAL CD4011AE CMOS                     | 02735    | CD4011AY           |

Table 6-4. Miscellaneous Parts.

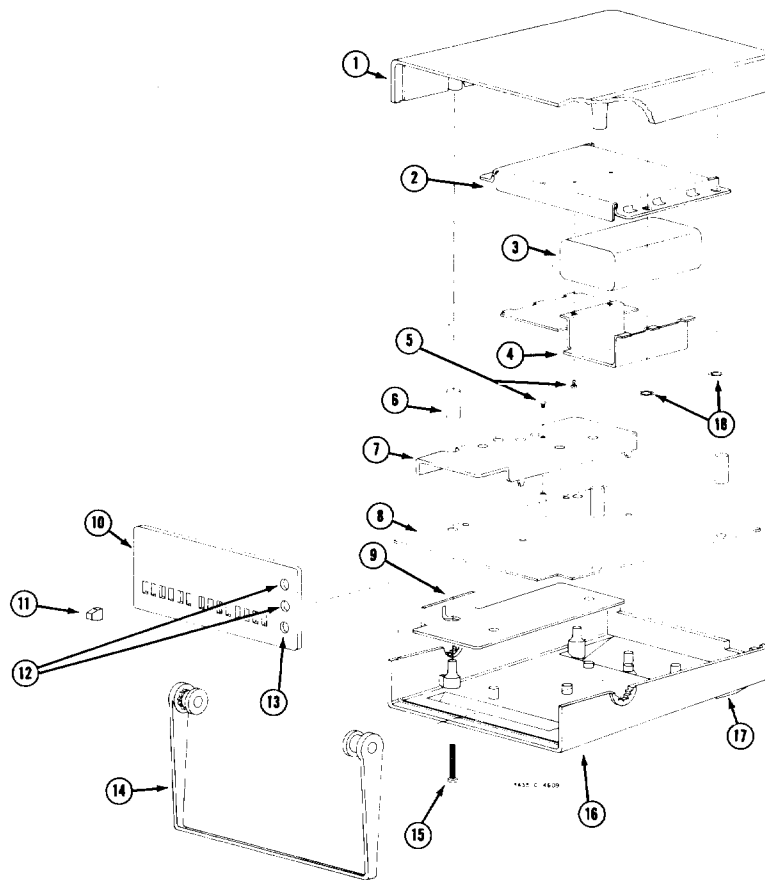

| INDEX NO. | -hp- PART NO. | DESCRIPTION                  | TQ |   |             |                                |   |
|-----------|---------------|------------------------------|----|---|-------------|--------------------------------|---|
| ①         | 5040-8085     | TOP SHELL                    | 1  | ⑪ | 0370-2873   | PUSHBUTTON KNOB (DARK GREY)    | 5 |
| ②         | 03435-00101   | BATTERY DECK                 | 1  | ⑪ | 0370-2917   | PUSHBUTTON KNOB (LIGHT BLUE)   | 1 |
| ③         | 1420-0233     | 6 VOLT BATTERY PAC           | 1  | ⑫ | 5040-7456   | BANANA JACK ASSY (J1, J2)      | 2 |
| ④         | 03435-01201   | BATTERY CLAMP                | 1  |   |             |                                |   |
| ⑤         | { 2360-0117   | 6 - 32 X 3/8                 | 3  |   | { 5060-7455 | AMPS INPUT FUSE HOLDER         | 1 |
|           | { 2360-0116   | 6 - 32 X 1/4                 | 1  |   | { 5040-8068 | FUSE SPRING HOLDER (NOT SHOWN) | 1 |
| ⑥         | 5040-8044     | POLYCARBONATE SPACER         | 4  | ⑬ | { 1460-1485 | FUSE SPRING (NOT SHOWN)        | 1 |
| ⑦         | 03435-00601   | A1 PC SHIELD (TOP)           | 1  |   | { 2110-0002 | AMPS INPUT FUSE (NOT SHOWN)    | 1 |
| ⑧         | 03435-66501   | A1 PC ASSEMBLY               | 1  | ⑭ | 5040-8058   | HANDLE/BAIL                    | 1 |
| ⑨         | 03435-00602   | BOTTOM SHIELD                | 1  | ⑮ | 2360-0137   | 6 - 32 X 1 3/4                 | 4 |
| ⑩         | 03435-00201   | FRONT PANEL                  | 1  | ⑯ | 03435-64401 | BOTTOM SHELL W/BOTTOM SHIELD   | 1 |
| ⑪         | 0370-2486     | PUSHBUTTON KNOB (LIGHT GREY) | 7  | ⑰ | 5040-7223   | NON-SKID PAD (FOOT)            | 2 |
| ⑫         | 0370-2625     | PUSHBUTTON KNOB (WHITE)      | 1  | ⑱ | 0510-0585   | PUSH-ON RETAINER               | 4 |

## SECTION VII CIRCUIT DIAGRAMS

### 7-1. INTRODUCTION.

7-2. This section of the manual contains troubleshooting information, simplified and complete schematic diagrams, and component locators.

### 7-3. SCHEMATIC DIAGRAMS.



*These servicing instructions are for use by qualified service personnel only. To avoid electrical shock, do not perform any servicing other than that contained in the operating instructions unless you are qualified to do so.*

7-4. The schematic diagrams, Figure 7-5 through 7-8 are a schematic representation of the Multimeter circuitry and its power supply. Figure 7-4 is a simplified schematic representation of the analog portion of the Multimeter.

### 7-5. TROUBLESHOOTING.

7-6. Troubleshooting procedures are performed after it is established that there is a failure in the Multimeter circuitry. Unless a failure is obvious, such as a blank display, refer to the Adjustment Procedures and Performance Checks in Section V before attempting to troubleshoot the Multimeter.



*The hybrid circuits in the Multimeter may be permanently damaged by static discharge from a hand or tool when the Multimeter is disassembled. The procedures below must be followed to prevent possible damage.*

1. *Ground the hand while disassembling and working on the Multimeter. Conductive wristbands (-hp- Part No. 00970-67900) are available for this purpose.*

2. *Attach the Multimeter COM terminal to earth ground. Touch all tools to earth ground to remove static charges before using them on the Multimeter.*

3. *Use a soldering iron with a grounded tip.*



*Wear clean cotton gloves when working on the circuit board. Contamination or fingerprints will reduce the accuracy of the Multimeter. Use low flux content solder (-hp- Part No. 8090-0512) when replacing components. Do not permit traces of flux to form on the circuit board. Observe precautions against static discharge. Do not use flux remover.*

### 7-7. Preliminary Troubleshooting.

7-8. **Front Panel Observations.** Without disassembling the Multimeter, failures can often be isolated by a simplified performance test and careful observance of display indications. This is especially true if the failure is a measurement error. Table 7-1 is a simplified performance test.

7-9. Record the results of the simplified performance test. Refer to Table 7-2 AC Gain and 7-3 DC Gain and Figure 7-1 Functional Block Diagram.

#### NOTE

*Circled letters (A) through (E) are reference points to aid in correlating between block, simplified, and complete schematic diagrams.*

7-10. Failure isolation between Input Amp and Post Amp can be evaluated by observing which particular ranges are in or out of specification.

Example 1:

|     |        |     |
|-----|--------|-----|
|     | 200 mV | IN  |
|     | 2 V    | IN  |
| acV | 20 V   | OUT |
|     | 200 V  | OUT |
|     | 1200 V | IN  |

The failure is probably associated with the input amp x .002 gain.

Example 2:

|     |        |     |
|-----|--------|-----|
|     | 200 mV | OUT |
|     | 2 V    | IN  |
| dcV | 20 V   | IN  |
|     | 200 V  | OUT |
|     | 1200 V | IN  |

The problem is probably associated with the post amp x 10 gain.

**Table 7-1. Simplified Performance Test.**

| Function | Range  | Input     | Multimeter Display Limits  |                             |
|----------|--------|-----------|----------------------------|-----------------------------|
| dcV      | 200 mV | 100 mVdc  | 99.7 to 100.3 mV           |                             |
|          | 2 V    | 1 Vdc     | .998 to 1.002 V            |                             |
|          | 20 V   | 10 Vdc    | 9.98 to 10.02 V            |                             |
|          | 200 V  | 100 Vdc   | 99.8 to 100.2 V            |                             |
| acV      | 200 mV | *100 mVac | 100 Hz<br>99.4 to 100.6 mV | 100 kHz<br>97.5 to 102.5 mV |
|          |        | *1 V Vac  | .994 to 1.006 V            | .975 to 1.025 V             |
|          | 20 V   | *10 Vac   | 9.94 to 10.06 V            | 9.94 to 10.06 V             |
|          |        | *100 Vac  | 99.4 to 100.6 V            | 97.5 to 102.5 V             |
|          | 1200 V | 1000 Vac  | 994 to 1006 V              |                             |
|          |        |           |                            |                             |
| kΩ       | 20 Ω   | 10 Ω      | 9.85 to 10.15 Ω            |                             |
|          | 2 kΩ   | 1 kΩ      | .996 to 1.004 kΩ           |                             |

\*Test at 100 Hz and 100 kHz.

**Table 7-2. AC Gain.**

| Range  | Input Voltage (A) | Input Amp (Gain) | Post Amp (Gain) | Post Amp Output (D) |
|--------|-------------------|------------------|-----------------|---------------------|
| 200 mV | .1 V              | .2               | x 10            | 200 mV              |
| 2 V    | 1 V               | .2               | x 1             | 200 mV              |
| 20 V   | 10 V              | .002             | x 10            | 200 mV              |
| 200 V  | 100 V             | .002             | x 1             | 200 mV              |
| 1200 V | 1 kV              | .0002            | x 1             | 200 mV              |

Example 2:

|        |     |
|--------|-----|
| 200 mV | OUT |
| 2 V    | IN  |
| 20 V   | OUT |
| 200 V  | IN  |
| 1200 V | IN  |

The failure is probably associated with the post amp x 10 gain.

7-12. The functional block diagram can be used to isolate failures as follows:

**Table 7-3. DC Gain.**

| Range  | Input Voltage (A) | Input Amp (Gain) | Post Amp (Gain) | Post Amp Output (C) |
|--------|-------------------|------------------|-----------------|---------------------|
| 200 mV | 100 mV            | X 1              | X 10            | 1 V                 |
| 2 V    | 1 V               | X 1              | X 1             | 1 V                 |
| 20 V   | 10 V              | X .1             | X 1             | 1 V                 |
| 200 V  | 100 V             | X .001           | X 10            | 1 V                 |
| 1200 V | 1000 V            | X .001           | X 1             | 1 V                 |

Example 1:

|      |     |
|------|-----|
| acV  | OUT |
| dcV  | OUT |
| Ohms | OUT |

The failure is probably associated with the input amp of the a to d converter.

Example 2:

|      |     |
|------|-----|
| acV  | OUT |
| dcV  | IN  |
| Ohms | IN  |

The failure is probably associated with the ac to dc converter.

7-11. 100 kHz frequency response failures are most often associated with the ac to dc converter or the post amp x 10 gain. This failure can also be isolated by recording and evaluating the ranges that are in or out of specification.

Example 1:

|        |     |
|--------|-----|
| 200 mV | OUT |
| 2 V    | OUT |
| 20 V   | OUT |
| 200 V  | OUT |
| 1200 V | OUT |

The failure is probably associated with the ac to dc converter.

**7-13. Disassembly Procedure.**

- a. Remove the Multimeter Power Cord.
- b. With the Multimeter in the inverted position, remove the four screws from the bottom cover.
- c. Carefully return the Multimeter to the upright position with the front panel facing you.

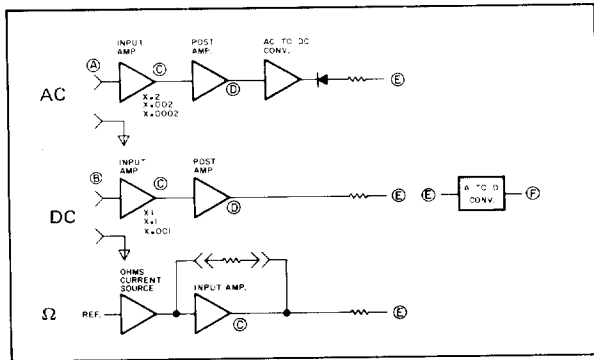

Figure 7-1. Functional Block Diagram.

**NOTE**

Battery and charger circuitry are located in the top shell and are connected to the main PC assembly by an 8 lead cable. To avoid possible damage to the cable or connectors, remove top cover slowly.

d. Remove the top shell vertically and place it at the right side of the lower shell in an inverted position. This will allow access to all internal adjustments while still being able to observe the display and change the switch settings.

**7-14. Visual Inspection.** Visually inspect the Multimeter for cracked or burned components, pinched or broken cables or corrosion contamination.

**7-15. General Troubleshooting Information.**

**7-16. Test Jumpers.** Test jumpers (JM) are strategically located on the A1 and A3 PC assemblies to aid in troubleshooting. In some locations JM's can be clipped open for circuit isolation. Table 7-4 lists the JM's and their function.

Table 7-4. Test Jumpers.

| JM Number | Voltage/Signal               | Usage  |
|-----------|------------------------------|--|
| JM 1      | External Hold                | Holds Display<br>Test Only   |
| JM 2      | 10 kHz Test                  |  |
| JM 102    | Input Amp Output             | Test Only  |
| JM 103    | Post Amp Output              |  |
| JM 201    | Slope Amp Output             |  |
| JM 202    | Comparator Output            |  |
| JM 203    | Run up Clock                 |  |
| JM 401    | V <sub>disp</sub> Supply     |  |
| JM 402    | V <sub>sub</sub> -2 V Supply |  |
| JM 403    | V <sub>sub</sub> -2 V Supply |  |
| JM 404    | V <sub>sub</sub> -2 V Supply |  |
| JM 405    | + 7 V Supply                 |  |
| JM 406    | + 7 V Supply                 | When Opened<br>disconnects V <sub>sub</sub> from U11, U12, U13<br>disconnects V <sub>sub</sub> from U11<br>disconnects V <sub>sub</sub> from U12<br>disconnects +7 V from U2, U3, U4, U5,<br>U6, U7, U12 |
| JM 407    | - 7 V Supply                 |  |
| JM 408    | - 7 V Supply                 | disconnects - 7 V from U5, U6, U7  |
| JM 801    | Converter Control Output     | opens converter control loop   |
| JM 802    | AC to DC Converter<br>Input  | disconnects input to the AC to<br>DC Converter   |

**NOTE**

The letter J etched on the A1 PC assembly denotes the JM designator on the schematics.

**7-17. Test Pads.** Logic control states (Hi = + 7 V, Low = 0 V) can be evaluated using the test pads. Table 7-5 lists the test pad by number and its associated function.

Table 7-5. Test Pads.

| No. | Usage   | No. | Usage                           |
|-----|---|-----|---------------------------------|
| 1   | Run Up Enable                                   | 6   | MRE Manual Range<br>Switch Code |
| 2   | FNA }<br>FNB } Function<br>FNC } Switch<br>Code | 7   | MRD Manual Range<br>Switch Code |
| 3   |   | 8   | Digital Ground                  |
| 4   |   | 9   | Run Down<br>Compensation (+)    |
| 5   | MRF Manual Range<br>Switch Code                 | 10  | No Connection                   |

**7-18. Power Supply and Battery Charger.** The power supply consists of three series regulators. The + 7 V supply is adjustable and provides a reference voltage to the - 7 V. + 7 V is the reference for the V<sub>disp</sub> supply if the battery option is not installed and JM 401 is connected.

7-19. Figure 7-2 is a block diagram of the battery charger circuitry. Figure 7-3 shows the relationship of charge voltage and current with the Multimeter off (fast charge) and on (slow charge).

**7-20. The V<sub>sub</sub> (- 2 V) Supply.** V<sub>sub</sub> is the substrate voltage for U11, U12, and U13. If this voltage is incorrect, individually opening JM 403, JM 404, and JM 402 while monitoring the V<sub>sub</sub> voltage will isolate the faulty integrated circuit.

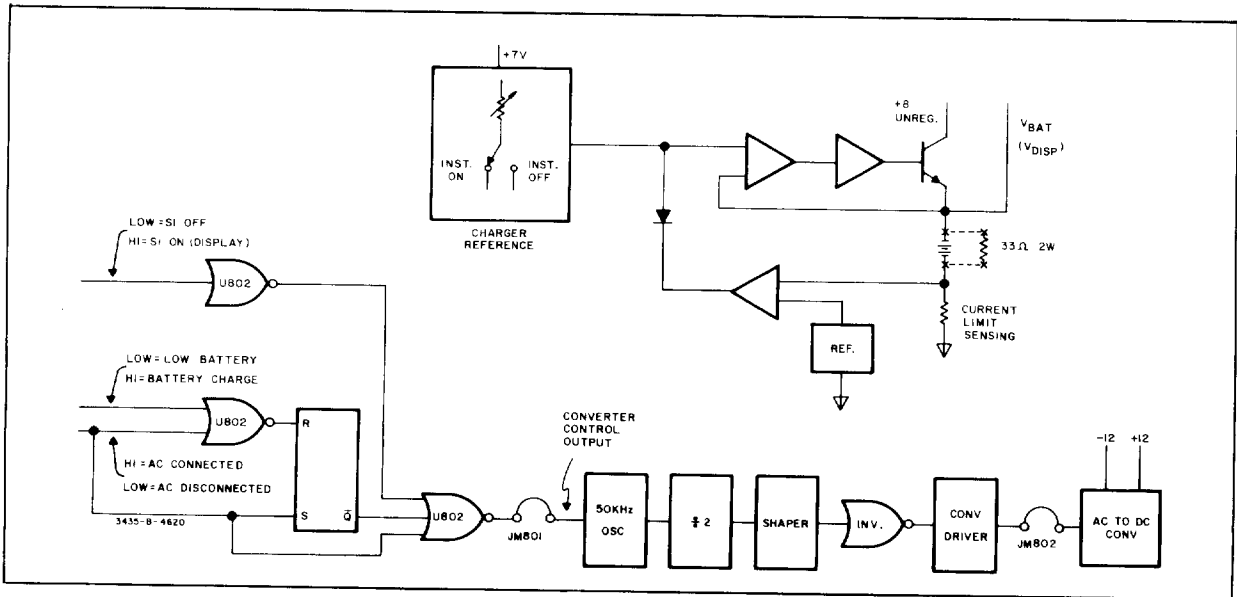

Figure 7-2. Battery Charger Block Diagram.

Table 7-6. Digital Troubleshooting.

| Function | Range   | R.U. EN | FNA | FNB | FNC | MRF | MRE | MRD | GND | R.D. Comp (+) |
|----------|---------|---------|-----|-----|-----|-----|-----|-----|-----|---------------|
| dc V     | 200 mV  | ⎓       | 1   | 1   | 0   | 0   | 0   | 0   | 0   | 1             |
|          | 2 V     |         | 1   | 1   | 0   | 0   | 0   | 1   | 0   | 1             |
|          | 20 V    |         | 1   | 1   | 0   | 0   | 1   | 1   | 0   | 1             |
|          | 200 V   |         | 1   | 1   | 0   | 1   | 1   | 1   | 0   | 1             |
|          | 1200 V  |         | 1   | 1   | 0   | 1   | 1   | 0   | 0   | 1             |
| ac V     | 200 mV  | 1       | 0   | 1   | 0   | 0   | 0   | 0   | 0   | 1             |
|          | 2 V     | 1       | 0   | 1   | 0   | 0   | 1   | 0   | 0   | 1             |
|          | 20 V    | 1       | 0   | 1   | 0   | 1   | 1   | 0   | 0   | 1             |
|          | 200 V   | 1       | 0   | 1   | 1   | 1   | 1   | 0   | 0   | 1             |
|          | 1200 V  | 1       | 0   | 1   | 1   | 1   | 0   | 0   | 0   | 1             |
| dc mA    | 200 μA  | 1       | 0   | 0   | 0   | 0   | 0   | 0   | 0   | 1             |
|          | 2 mA    | 1       | 0   | 0   | 0   | 0   | 0   | 1   | 0   | 1             |
|          | 20 mA   | 1       | 0   | 0   | 0   | 1   | 1   | 0   | 0   | 1             |
|          | 200 mA  | 1       | 0   | 0   | 1   | 1   | 1   | 0   | 0   | 1             |
|          | 2000 mA | 1       | 0   | 0   | 1   | 1   | 0   | 0   | 0   | 1             |
| ac mA    | 200 μA  | 0       | 0   | 0   | 0   | 0   | 0   | 0   | 0   | 1             |
|          | 2 mA    | 0       | 0   | 0   | 0   | 0   | 0   | 1   | 0   | 1             |
|          | 20 mA   | 0       | 0   | 0   | 0   | 1   | 1   | 0   | 0   | 1             |
|          | 200 mA  | 0       | 0   | 0   | 1   | 1   | 1   | 0   | 0   | 1             |
|          | 2000 mA | 0       | 0   | 0   | 1   | 1   | 0   | 0   | 0   | 1             |
| k Ω      | 20 Ω    | 1       | 1   | 1   | 0   | 1   | 0   | 0   | 0   | 1             |
|          | 200 Ω   | 0       | 1   | 1   | 0   | 0   | 0   | 0   | 0   | 1             |
|          | 2 kΩ    | 1       | 1   | 1   | 0   | 0   | 1   | 0   | 0   | 1             |
|          | 20 kΩ   | 1       | 1   | 1   | 0   | 1   | 1   | 0   | 0   | 1             |
|          | 200 kΩ  | 1       | 1   | 1   | 1   | 1   | 1   | 0   | 0   | 1             |
|          | 2000 kΩ | 1       | 1   | 1   | 1   | 1   | 0   | 0   | 0   | 1             |
|          | 20 MΩ   | 1       | 1   | 1   | 1   | 0   | 0   | 0   | 0   | 1             |

Measurements taken with V/Ω to COM shorted.  
 1 = 7 V  
 0 = 0 V  
 ⎓ = Clock

**7-21. Analog Troubleshooting.**

7-22. Failures in the analog circuitry can best be analyzed by studying the Simplified Schematic, Figure 7-4.

**7-23. Gain Verification.** Ac and dc gain for the input and post amplifiers can be verified by referring to Table 7-2 and 7-3. Apply the input voltages and verify the amplifier outputs with a oscilloscope at JM 102 (Input) and JM 103 (Post).

**7-24. Auto Zero Loop.** The auto zero loop can best be troubleshot by holding the loop closed. This is accomplished by the following procedure:

- a. Set the Multimeter for dcV function 2 V range.

- b. Connect a jumper (short) across the A (amps) to COM terminals.

7-25. The voltage at U12 pin 2 should be  $\pm 0.1$  V and should vary  $\pm 10$  mV as R203 is varied through its adjustment range.

7-26. The voltage at U2 pin 2 and U3 pin 3 should be  $< 20$  mV.

**7-27. Digital Troubleshooting.**

7-28. Troubleshooting the digit portion can best be accomplished using the Test Pads 1 through 9. Table 7-6 compares test pad voltages with changes in function and range switches.

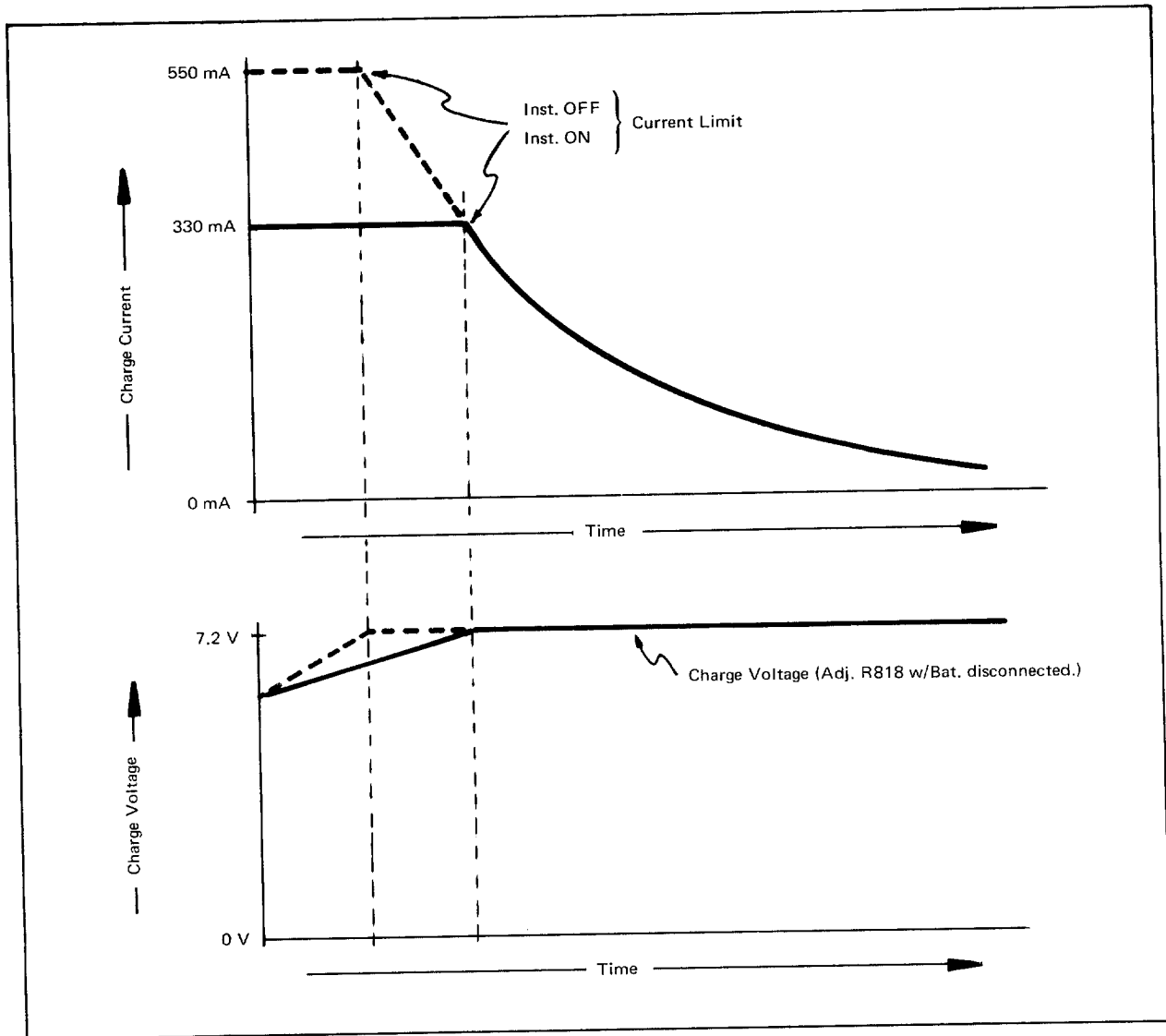
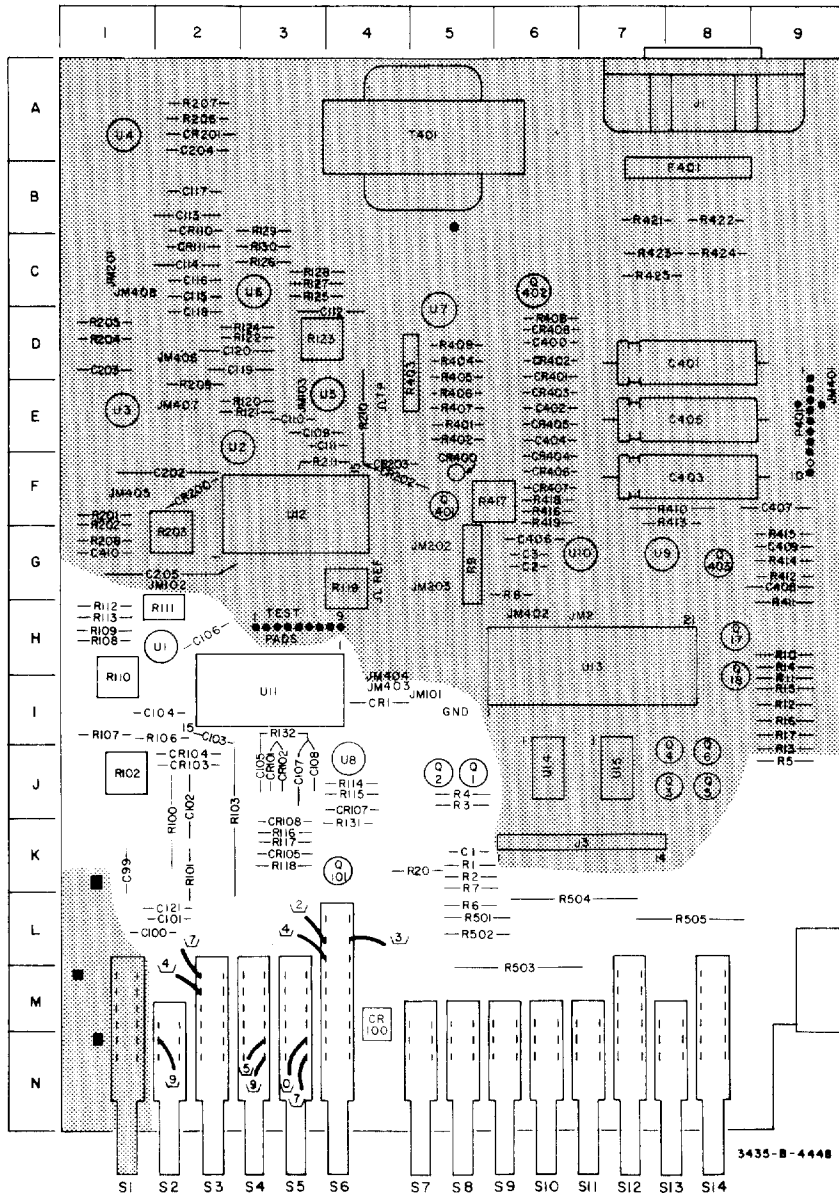

Figure 7-3. Charge Current/Voltage.



UNSHADED AREAS  
FOR THIS SCHEMATIC

A1 COMPONENT LOCATIONS

|     | C  | CR | R  |
|-----|----|----|----|
| 1   | K5 | I4 | K5 |
| 2   |    |    | K5 |
| 3   |    |    | J5 |
| 4   |    |    | J5 |
| 5   |    |    | J9 |
| 6   |    |    | L5 |
| 7   |    |    | K5 |
| 20  |    |    | K4 |
| 99  | K1 |    |    |
| 100 | L2 | M4 | K2 |
| 101 | L2 | J3 | K2 |
| 102 | J2 | J3 | J1 |
| 103 | I2 | J2 | J3 |
| 104 | I2 | J2 |    |
| 105 | J3 | K3 |    |
| 106 | H2 |    | I2 |
| 107 | J3 | J4 | I1 |
| 108 | J3 | K3 | H1 |
| 109 |    |    | H1 |
| 110 |    |    | I1 |
| 111 |    |    | H2 |
| 112 |    |    | H1 |
| 113 |    |    | H1 |
| 114 |    |    | J4 |
| 115 |    |    | J4 |
| 116 |    |    | K3 |
| 117 |    |    | K3 |
| 118 |    |    | K3 |
| 121 | L2 |    |    |
| 131 |    |    | K4 |
| 132 |    |    | I3 |
| 501 |    |    | L5 |
| 502 |    |    | L5 |
| 503 |    |    | M6 |
| 504 |    |    | L7 |
| 505 |    |    | L8 |

A1

hp- Part No. 03435-66501

AC VOLTS FUNCTION

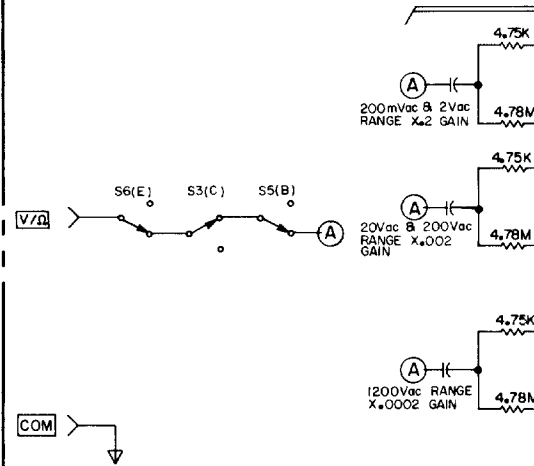

AMPS FUNCTION

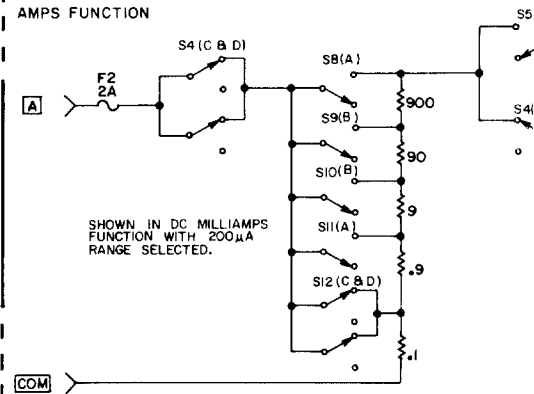

OHMS FUNCTION

SHOWN IN OHMS FUNCTION WITH  
2KΩ RANGE SELECTED.

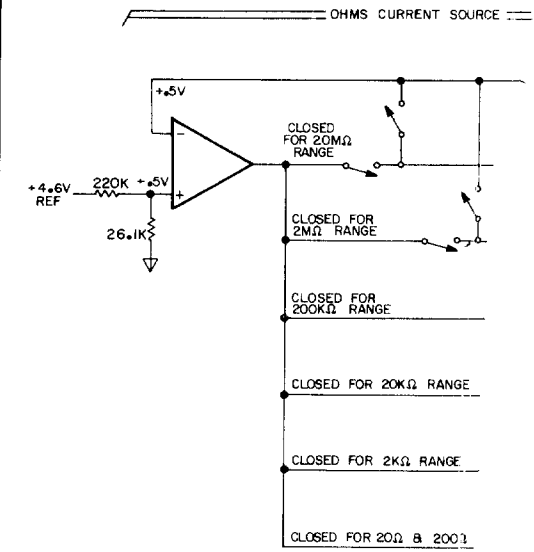

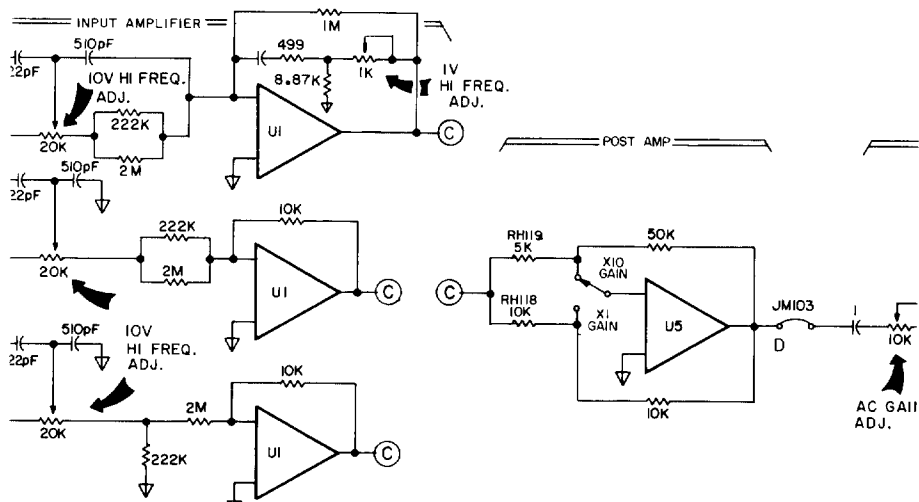

- b)  $\text{A (AC)}$
- c)  $\text{B (DC)}$

DC VOLTS FUNCTION

SHOWN IN dc VOLTS FUNCTION WITH 200mV RANGE SELECTED.

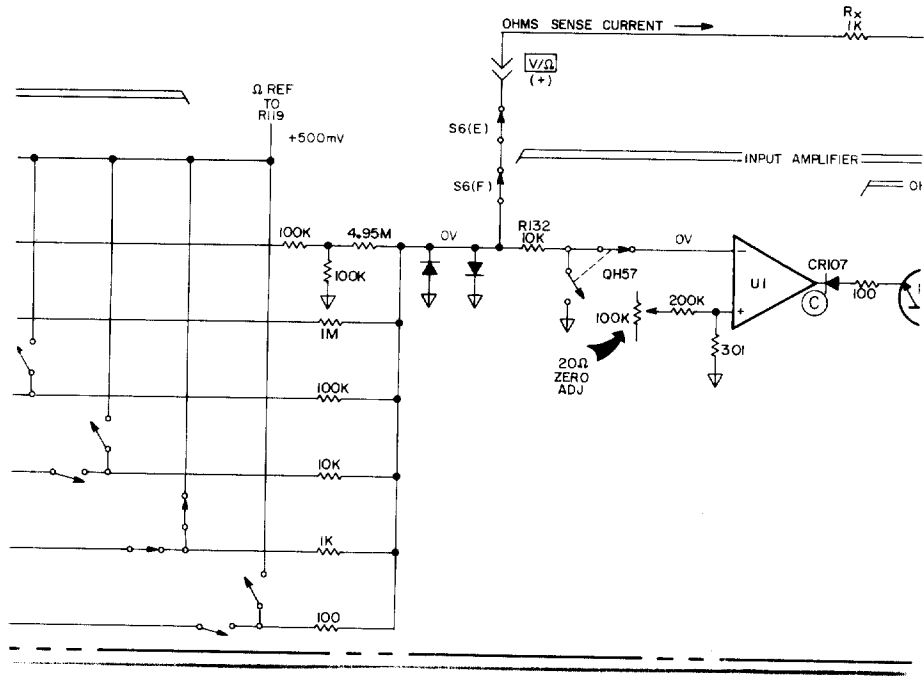
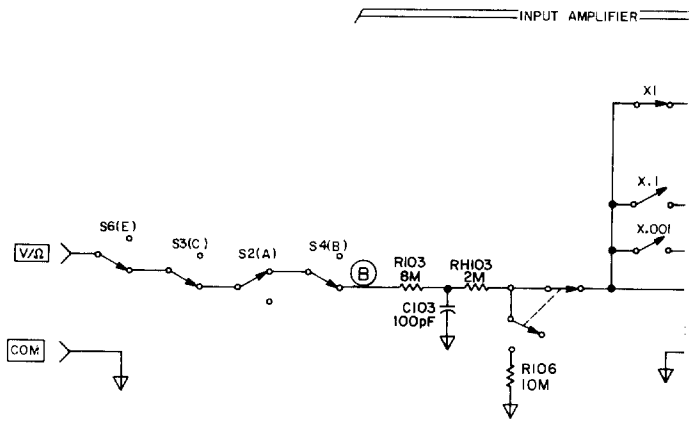

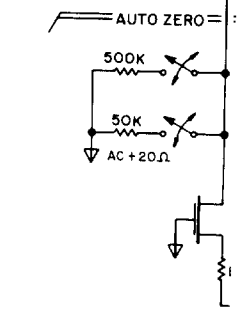
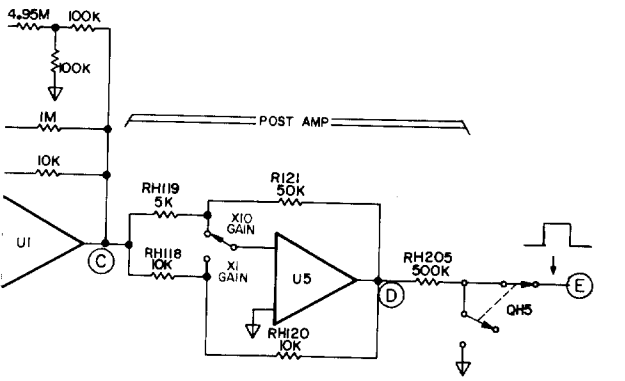
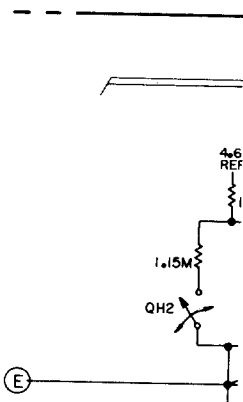
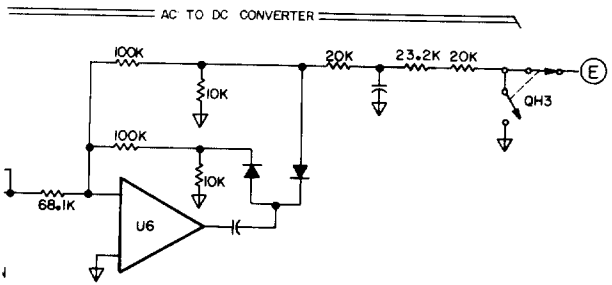

3435-E-4E

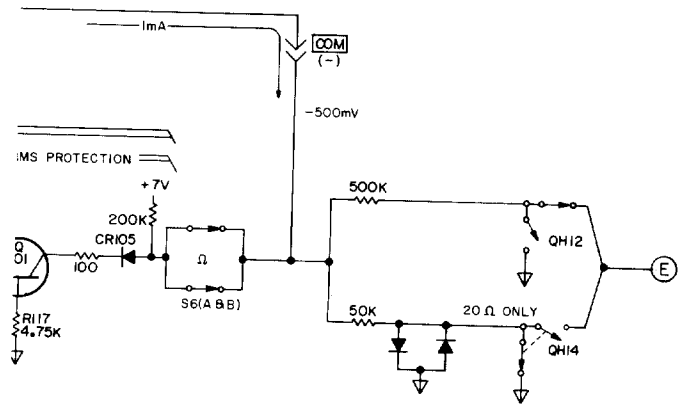

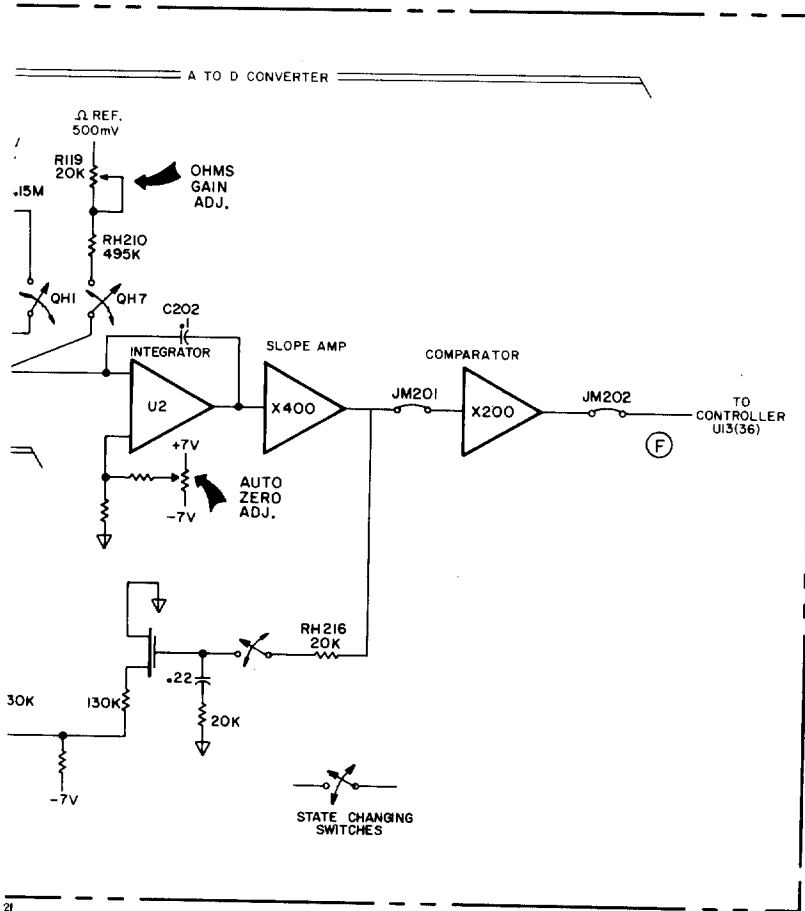

Figure 7-4. Simplified Analog Schematic.  
7-7

NOTE 1

THE SCHEMATIC IS SHOWN WITH DCV (FUNCTION) AND .2 V (RANGE) SELECTED. PROMINANT SCHEMATIC LINES SHOW THE SIGNAL PATH FOR THIS SWITCH SETTING.

NOTE 2

SWITCHES S2 THROUGH S14 ARE SCHEMATICALLY ORIENTED IN ASCENDING NUMERICAL ORDER FROM LEFT TO RIGHT. THIS ORIENTATION IS THE SAME AS THE PHYSICAL ORIENTATION OF THE ACTUAL SWITCHES AS THEY ARE VIEWED ON THE COMPONENT LOCATOR FIGURE 7-5. SWITCH SECTIONS ARE LABELED A THROUGH F ON THE SCHEMATIC AS SHOWN ON THE COMPONENT LOCATOR OF FIGURE 7-5.

NOTE 3

U11, U12, AND U13 ARE HYBRID INTEGRATED CIRCUITS. FINE LINE RESISTORS AND MOS FET SWITCHES WHICH ARE PART OF THE HYBRIDS ARE SHOWN ON THE SCHEMATIC FOR OPERATIONAL CLARIFICATION ONLY. THESE COMPONENTS ARE NOT INDIVIDUALLY SERVICEABLE.

NOTE 4

SIMPLIFIED SCHEMATIC REPRESENTATIONS OF MOS FET SWITCHES ARE USED FOR SCHEMATIC CLARITY. COMPARISONS OF THE SIMPLIFIED, ACTUAL AND FUNCTIONAL SCHEMATIC REPRESENTATIONS ARE AS FOLLOWS:

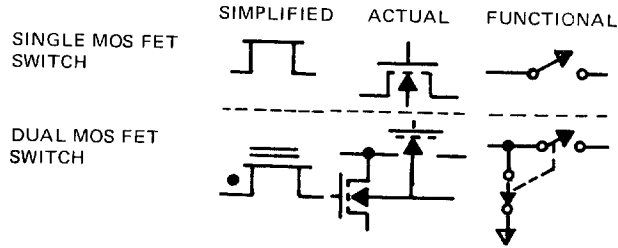

| RANGE             | CODE |      |      |      |
|-------------------|------|------|------|------|
|                   | MRD  | MRE  | MRF  | AUTO |
| 20 Ω (S7)         | 0    | 1    | 0    | 1    |
| 200 (S8)          | 0    | 0    | 0    | 1    |
| 2 (S9)            | 1    | 0    | 0    | 1    |
| 20 (S10)          | 1    | 1    | 0    | 1    |
| 200 (S11)         | 1    | 1    | 1    | 1    |
| 2000 (S12)        | 0    | 1    | 1    | 1    |
| 20 MΩ (S13)       | 0    | 0    | 1    | 1    |
| AUTO/MANUAL (S14) | OPEN | OPEN | OPEN | 0    |

| FUNCTION | CODE |     |     |
|----------|------|-----|-----|
|          | FNA  | FNB | FNC |
| DCV (S2) | 1    | 1   | 0   |
| ACV (S3) | 1    | 0   | 1   |
| DCI (S4) | 1    | 0   | 0   |
| ACI (S5) | 0    | 0   | 0   |
| Ω (S6)   | 1    | 1   | 1   |

1 = +7 V  
 0 = 0 V ( )  
 MRD = MANUAL RANGE LINE "D"  
 FNA = FUNCTION LINE "A"

**8 A I** MULTIMETER (03435-66501)

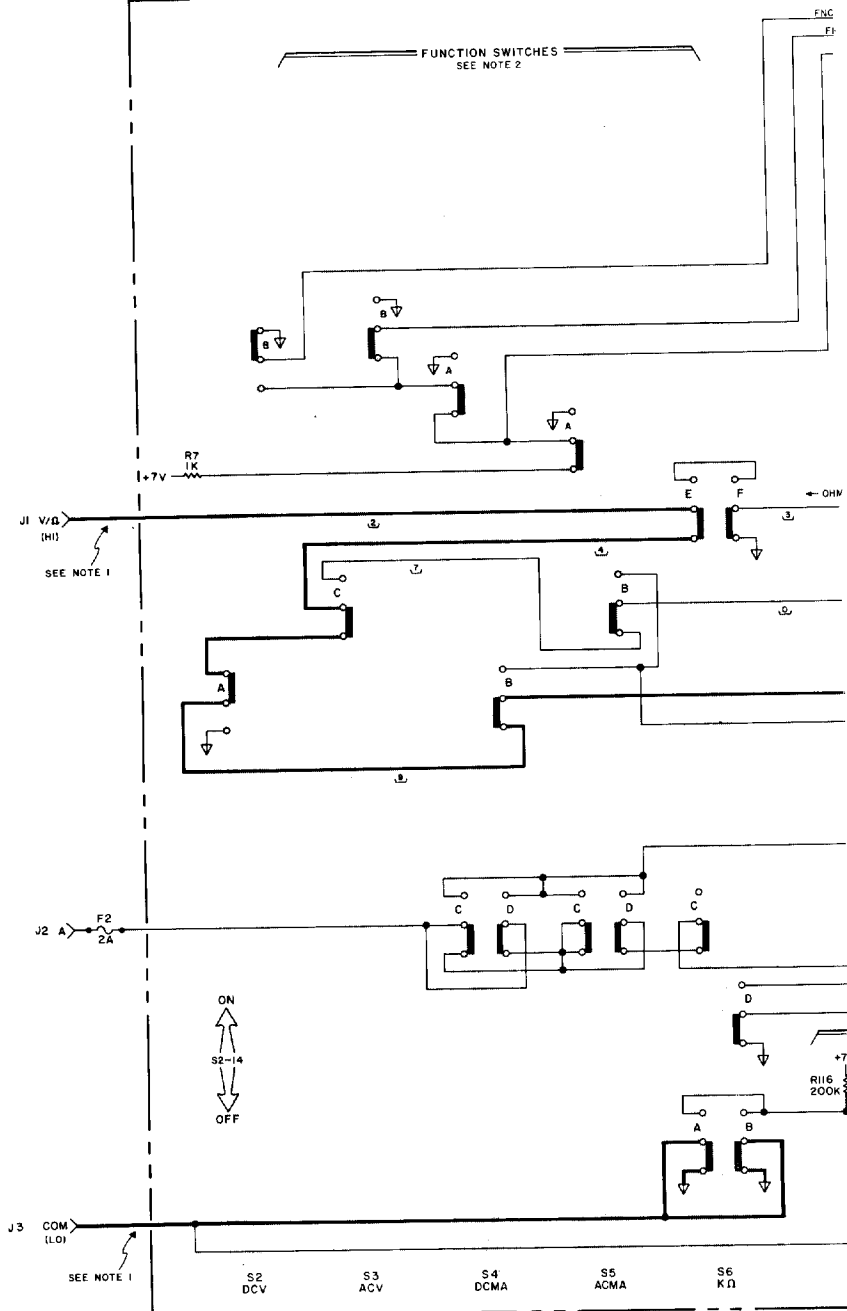

MANUAL SWITCHES  
SEE NOTE 2

B  
NA

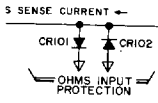
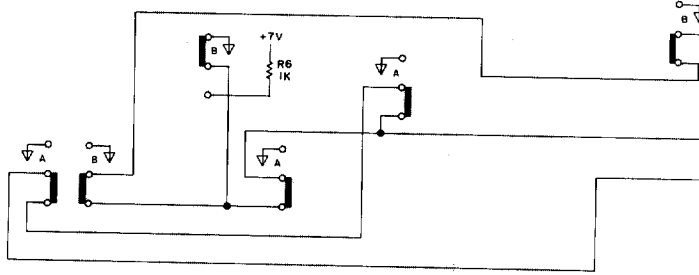

(A)

AC AND DC CURRENT SHUNTS

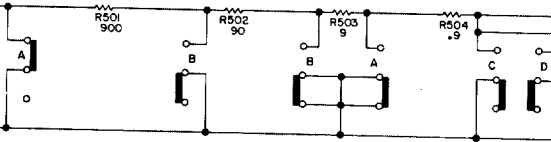
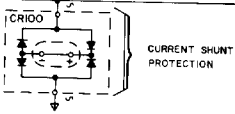
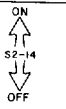

OHMS PROTECTION

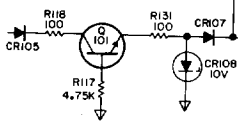

S7  
20 Ω ONLY

S8  
+2

S9  
2

S10  
20

S11  
200

S12  
2000

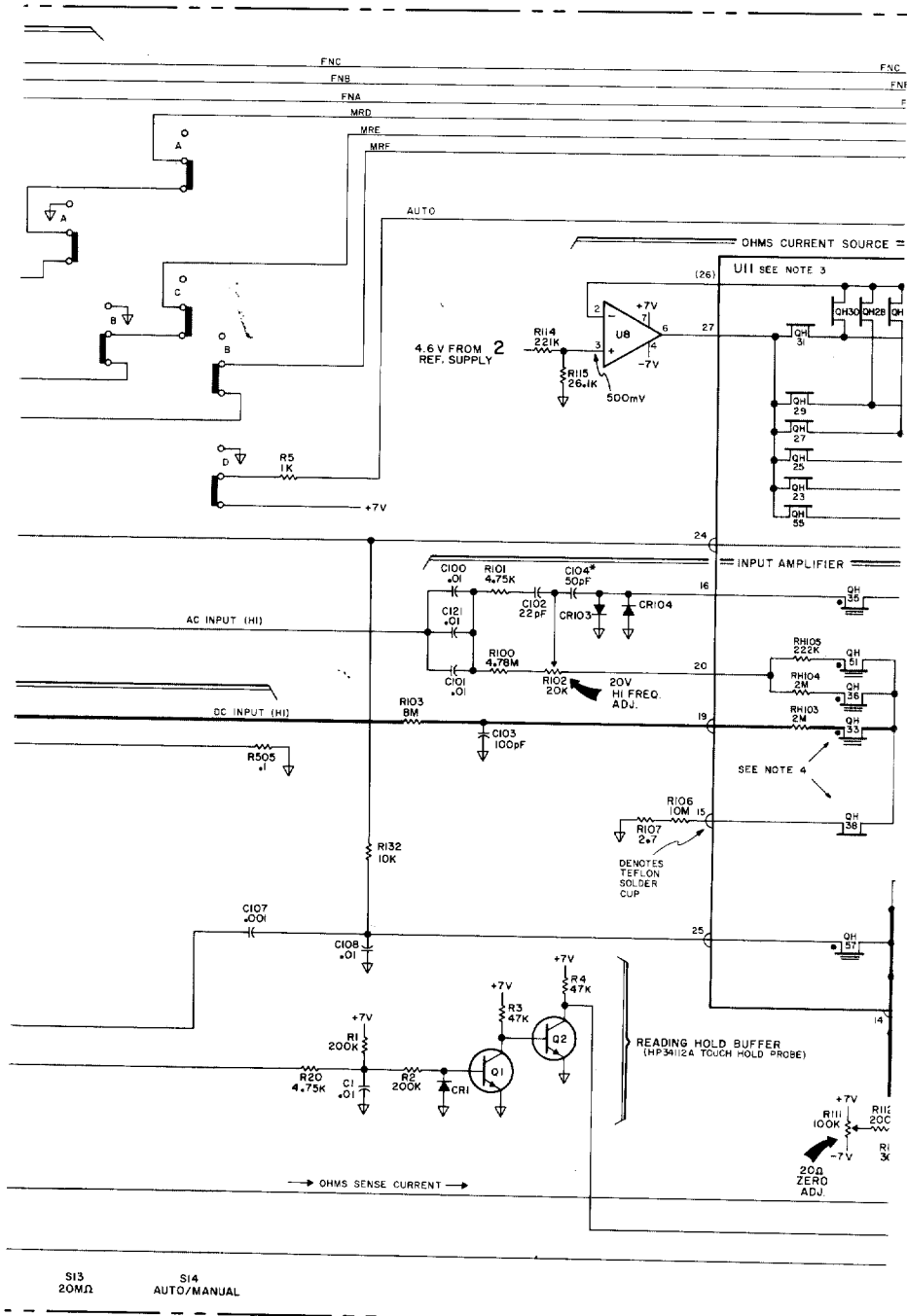

S13  
20Ω

S14  
AUTO/MANUAL

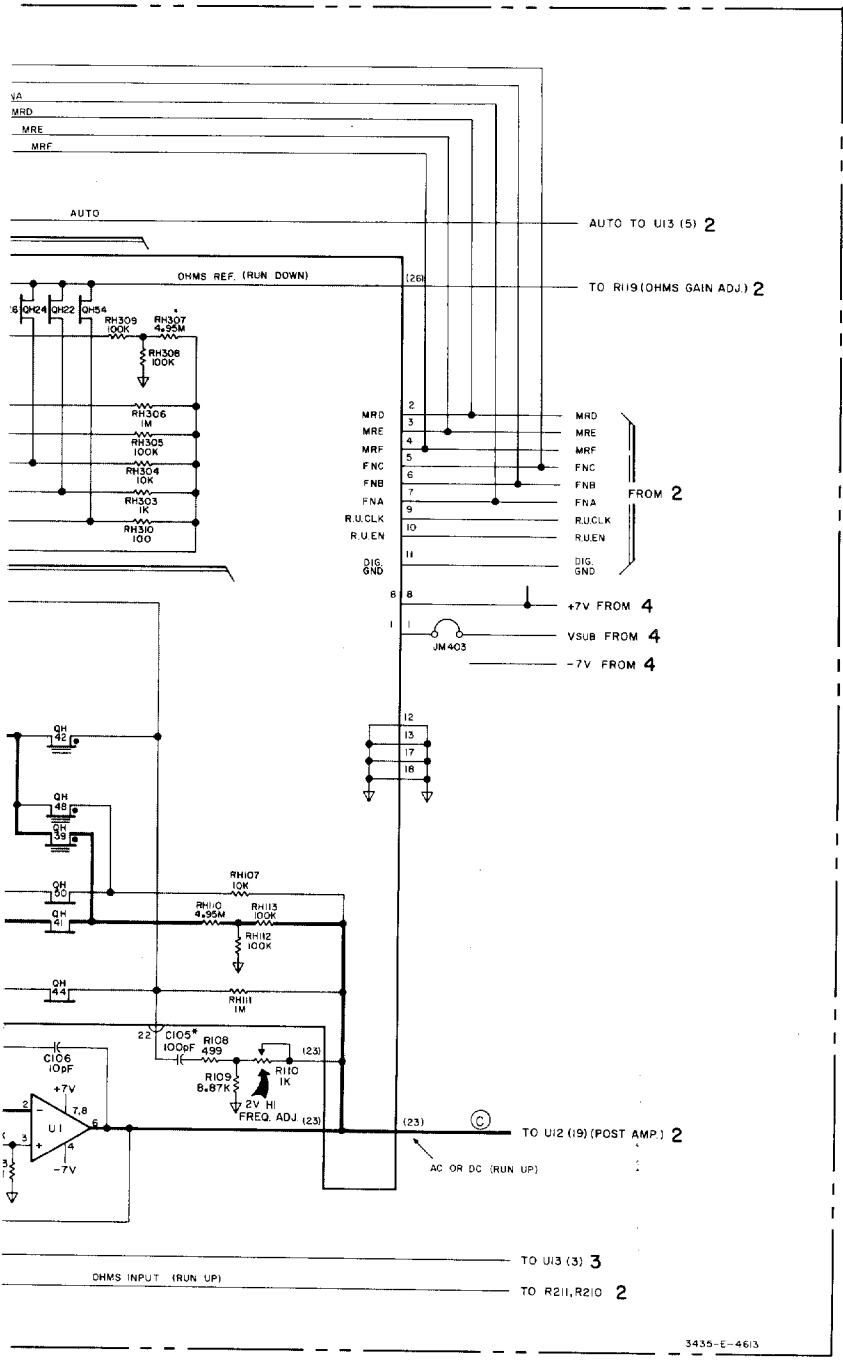
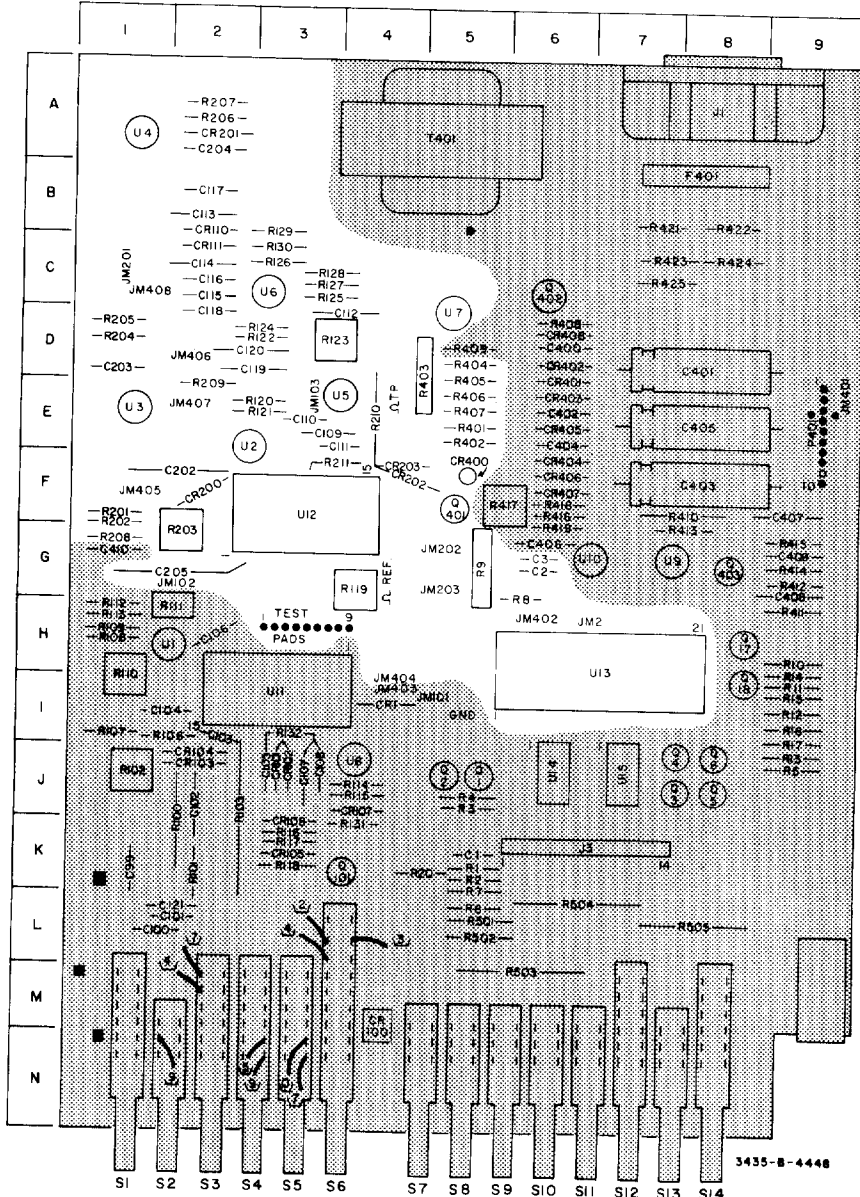

Figure 7-5. 3435A Input Switching, Input Amplifier and Ohms Current Source Schematic .

7-9/7-10

UNSHADED AREAS  
FOR THIS SCHEMATIC



A1

-hp- Part No. 03435-66501

A1 COMPONENT LOCATIONS

|     | C  | CR | R  | U  |
|-----|----|----|----|----|
| 2   | G6 |    |    | E2 |
| 3   | G6 |    |    | E1 |
| 4   |    |    |    | A1 |
| 5   |    |    |    | E3 |
| 6   |    |    |    | C3 |
| 8   |    |    | G6 |    |
| 9   |    |    | G5 |    |
| 12  |    |    |    | F3 |
| 13  |    |    |    | H7 |
| 109 | E3 |    |    |    |
| 110 | E3 | B2 |    |    |
| 111 | E3 | C2 |    |    |
| 112 | D2 |    |    |    |
| 113 | B2 |    |    |    |
| 114 | C2 |    |    |    |
| 115 | C2 |    |    |    |
| 116 | C2 |    |    |    |
| 117 | B2 |    |    |    |
| 118 | D2 |    |    |    |
| 119 | D2 |    | G4 |    |
| 120 | D2 |    | E3 |    |
| 121 |    |    |    | E3 |
| 122 |    |    |    | D3 |
| 123 |    |    |    | D3 |
| 124 |    |    |    | D3 |
| 125 |    |    |    | C3 |
| 126 |    |    |    | C3 |
| 127 |    |    |    | C3 |
| 128 |    |    |    | C3 |
| 129 |    |    |    | B3 |
| 130 |    |    |    | C3 |
| 200 |    | F2 |    |    |
| 201 |    | A2 | F1 |    |
| 202 | F2 | A2 | G1 |    |
| 203 | D1 | F4 | G2 |    |
| 204 | A2 |    | D1 |    |
| 205 | G2 |    | D1 |    |
| 206 |    |    | A2 |    |
| 207 |    |    | A2 |    |
| 208 |    |    | G1 |    |
| 209 |    |    | E2 |    |
| 210 |    |    | E4 |    |
| 211 |    |    | F3 |    |
| 400 |    | F5 |    |    |
| 401 |    |    | E5 |    |
| 402 |    |    | E5 |    |
| 403 |    |    | E4 |    |
| 404 |    |    | D5 |    |
| 405 |    |    | D5 |    |
| 406 |    |    | E5 |    |
| 407 |    |    | E5 |    |

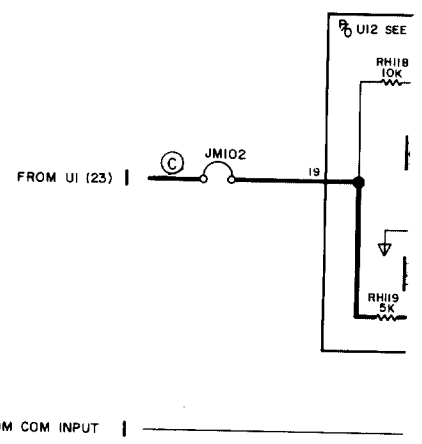
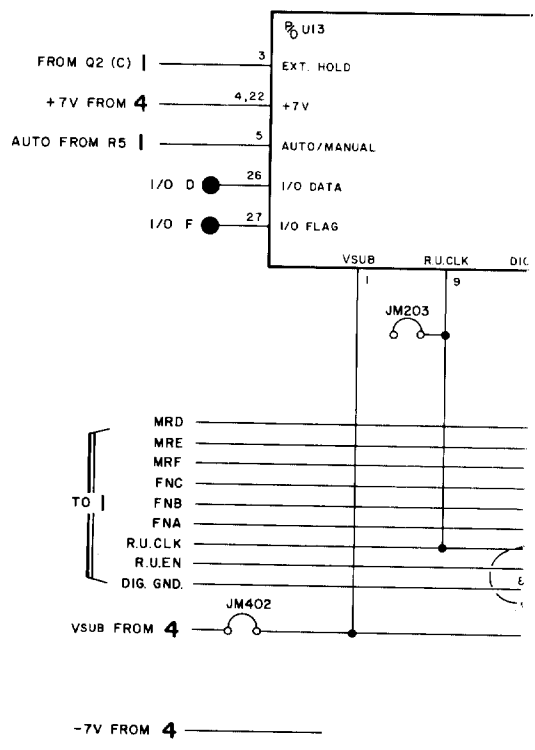

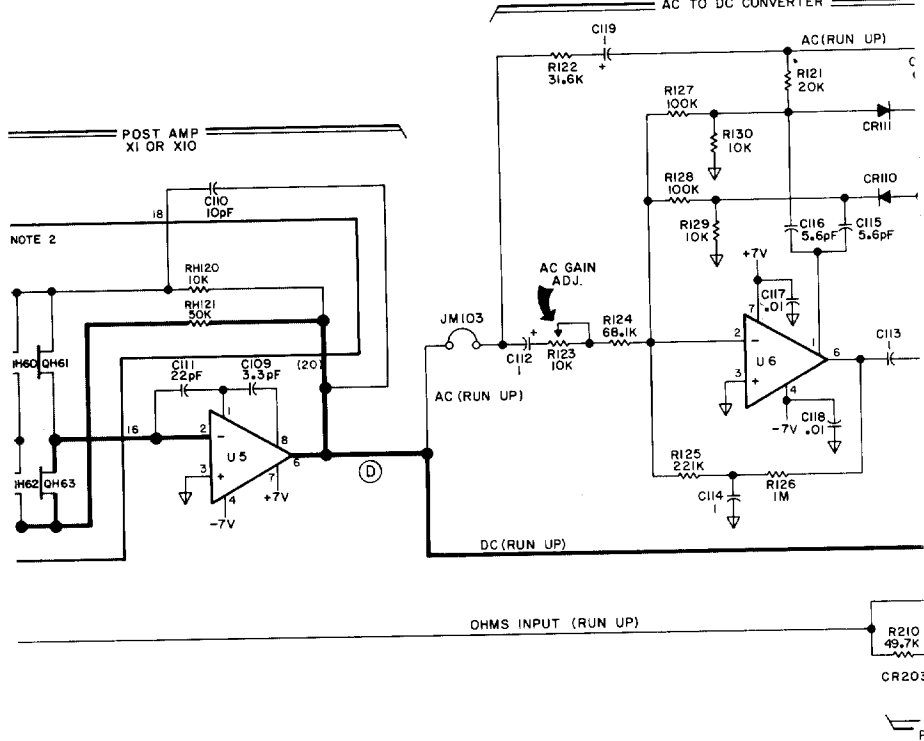
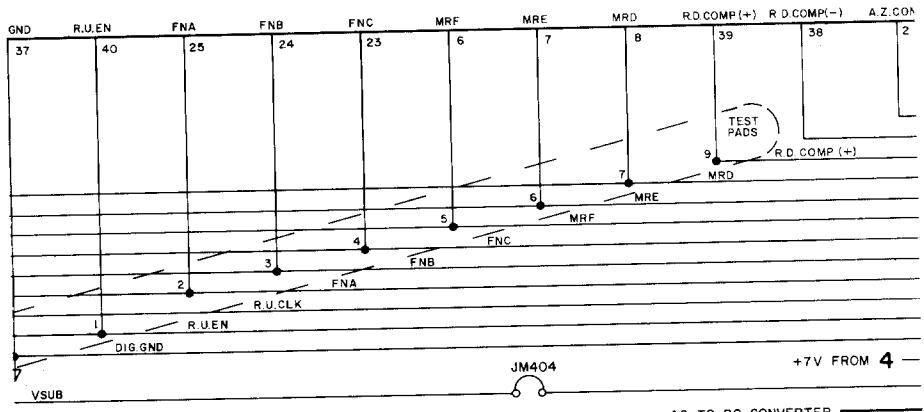

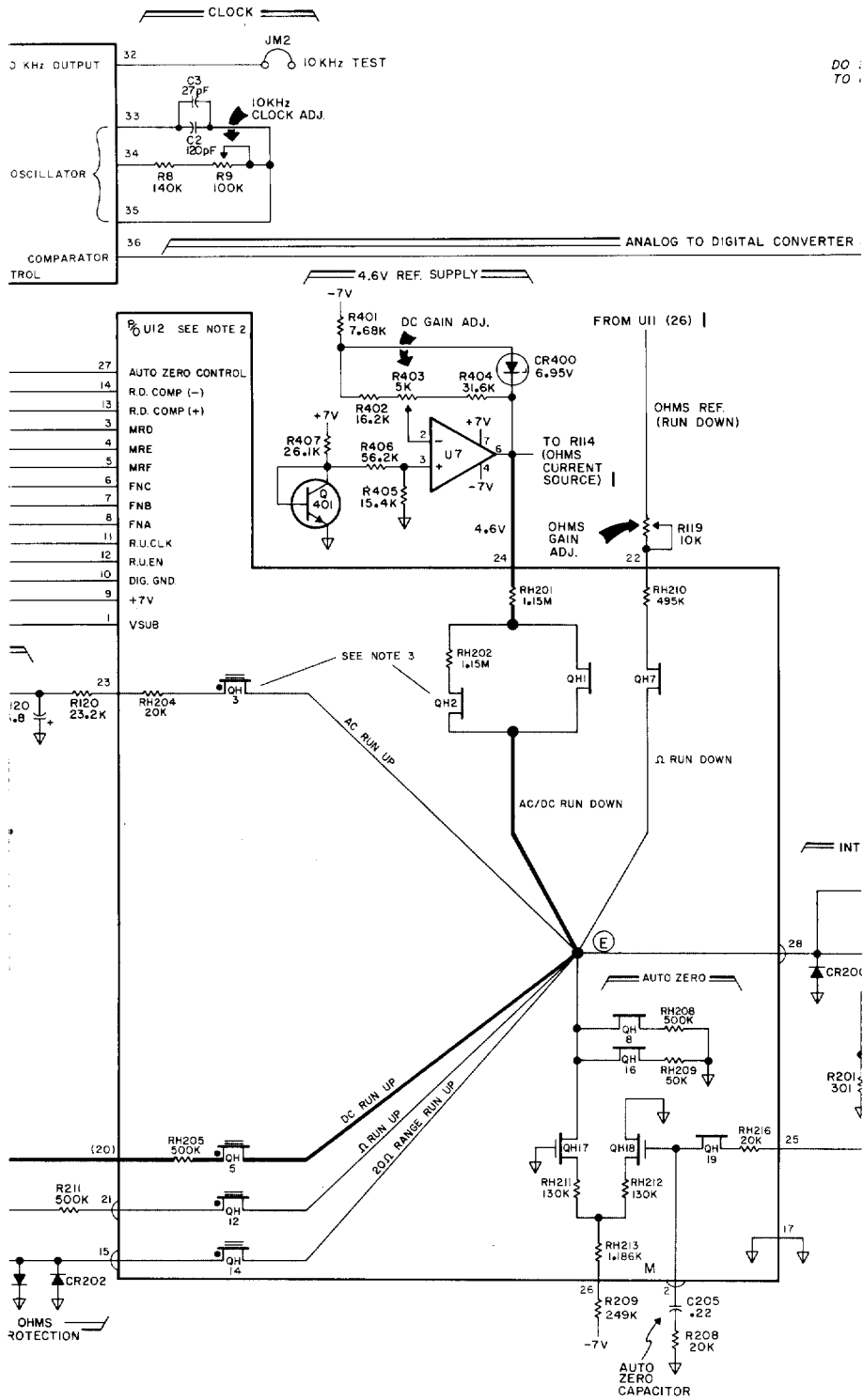

DO :  
TO :

— CAUTION —

NOT CONNECT TEST LEADS  
TO PIN 33, 34, OR 35.

NOTES

1. THE SCHEMATIC IS SHOWN WITH DCV (FUNCTION) AND  $\cdot 2V$  (RANGE) SELECTED. PROMINANT SCHEMATIC LINE SHOWS THE SIGNAL PATH FOR THIS SWITCH SETTING.
2. U11, U12, AND U13 ARE HYBRID INTEGRATED CIRCUITS. FINE LINE RESISTORS AND MOS FET SWITCHES WHICH ARE PART OF THE HYBRIDS ARE SHOWN ON THE SCHEMATIC FOR OPERATIONAL CLARIFICATION ONLY. THESE COMPONENTS ARE NOT INDIVIDUALLY SERVICEABLE.
3. SIMPLIFIED SCHEMATIC REPRESENTATIONS OF MOS FET SWITCHES ARE USED FOR SCHEMATIC CLARITY. COMPARISONS OF THE SIMPLIFIED, ACTUAL AND FUNCTIONAL REPRESENTATIONS ARE AS FOLLOWS:

|                       | SIMPLIFIED | ACTUAL | FUNCTIONAL |
|-----------------------|------------|--------|------------|
| SINGLE MOS FET SWITCH |            |        |            |
| DUAL MOS FET SWITCH   |            |        |            |

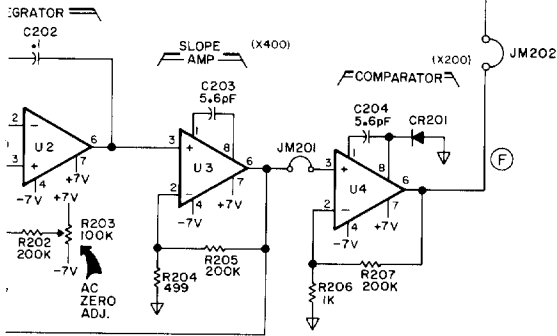

E-4615

2

Figure 7-6. 3435A Post Amplifier, AC to DC Converter and Analog to Digital Converter Schematic.

7-11/7-12

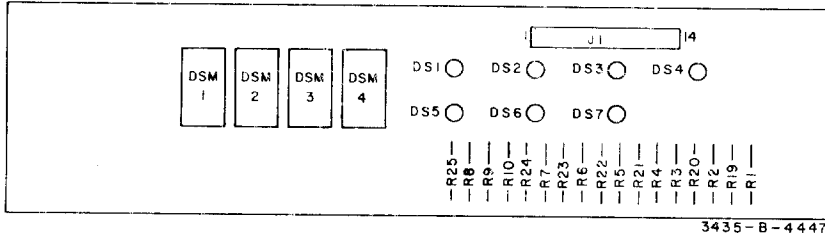

A2  
-hp- Part No. 03435-66502

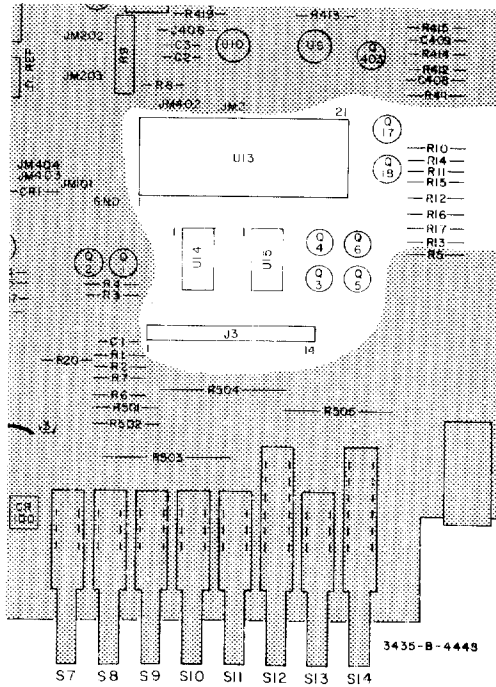

UNSHADED AREAS  
FOR THIS SCHEMATIC

A1  
-hp- Part No. 03435-66501

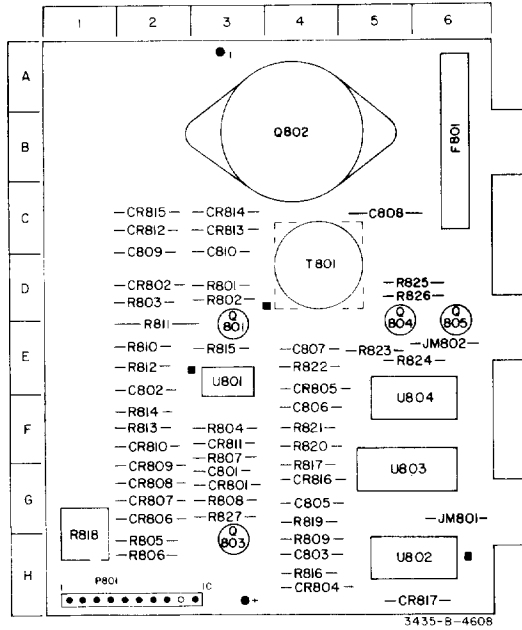

**A3**  
-hp- Part No. 03435-66503

**COMPONENT LOCATIONS**

|     | C  | CR | R  |
|-----|----|----|----|
| 801 | G3 | G3 | D3 |
| 802 | E2 | D2 | D3 |
| 803 | H4 |    | D2 |
| 804 |    | H4 | F3 |
| 805 | G4 | E4 | H2 |
| 806 | F4 | G2 | H2 |
| 807 | E4 | G2 | F3 |
| 808 | C5 | G2 | G3 |
| 809 | C2 | G2 | H4 |
| 810 | C3 | F2 | E2 |
| 811 |    | F3 | E2 |
| 812 |    | C2 | E2 |
| 813 |    | C3 | F2 |
| 814 |    | C3 | F2 |
| 815 |    | C2 | E3 |
| 816 |    | G4 | H4 |
| 817 |    | H5 | G4 |
| 818 |    |    | H1 |
| 819 |    |    | G4 |
| 820 |    |    | F4 |
| 821 |    |    | F4 |
| 822 |    |    | E4 |
| 823 |    |    | E5 |
| 824 |    |    | E5 |
| 825 |    |    | D5 |
| 826 |    |    | D5 |
| 827 |    |    | G3 |

**POWER SUPPLY JUMPERS**

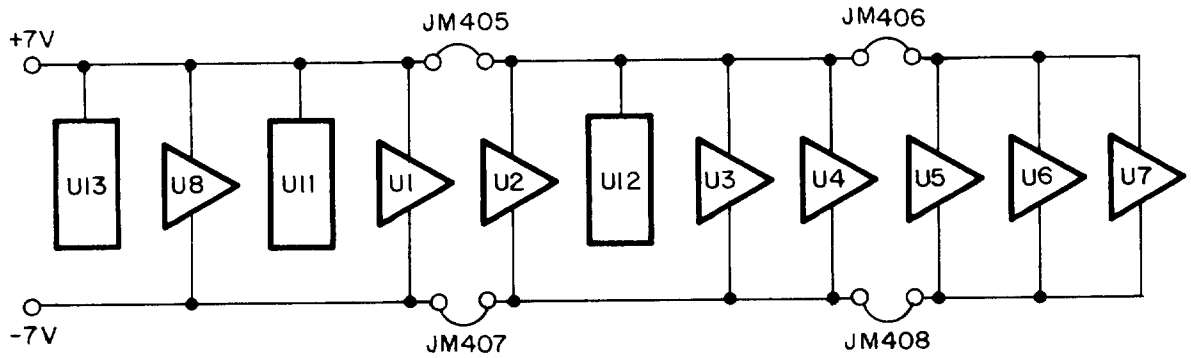

NOTE

JM 405 THROUGH JM 408 ARE NOT SHOWN ON THE SCHEMATIC DIAGRAMS.

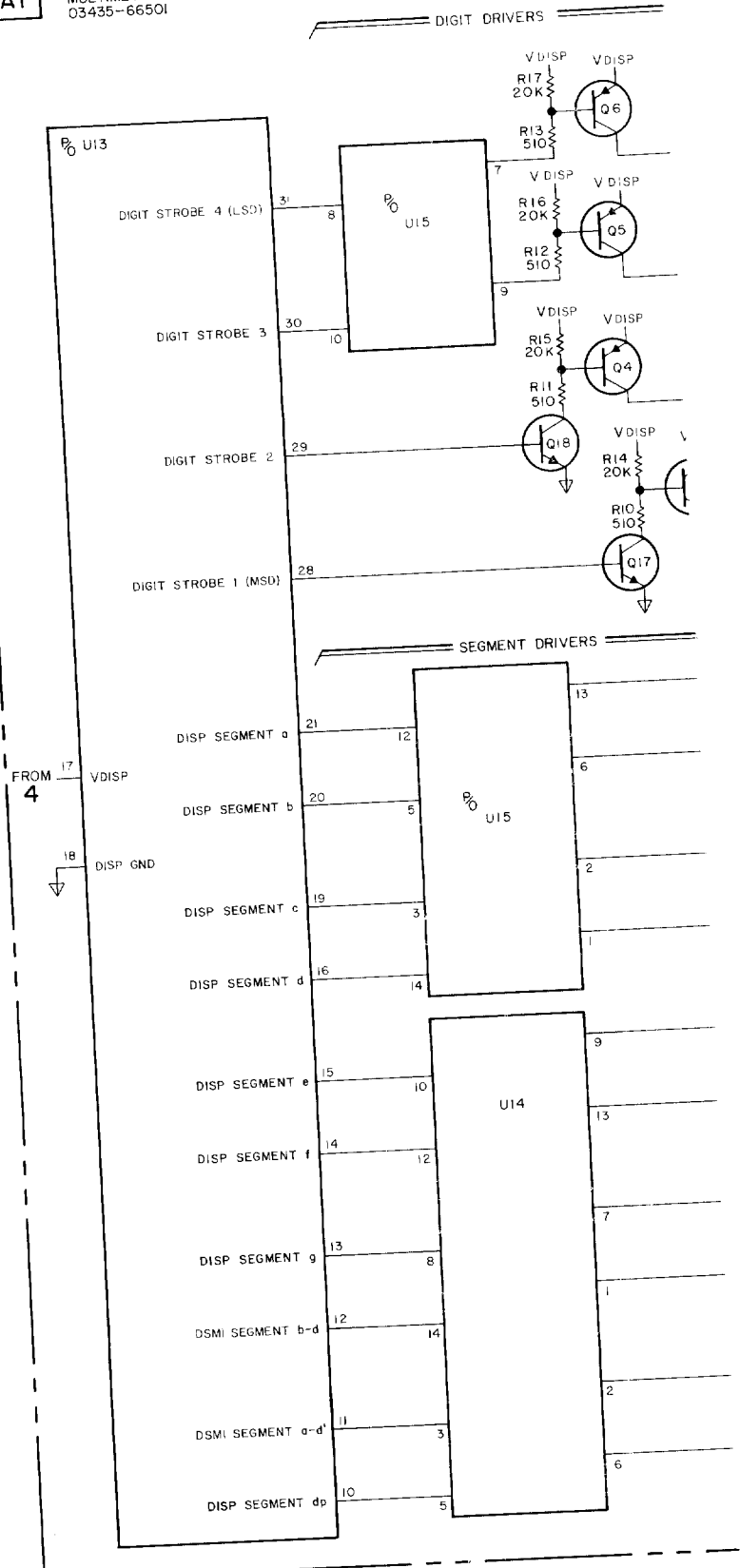

A2

DISPLAY  
03435-66502

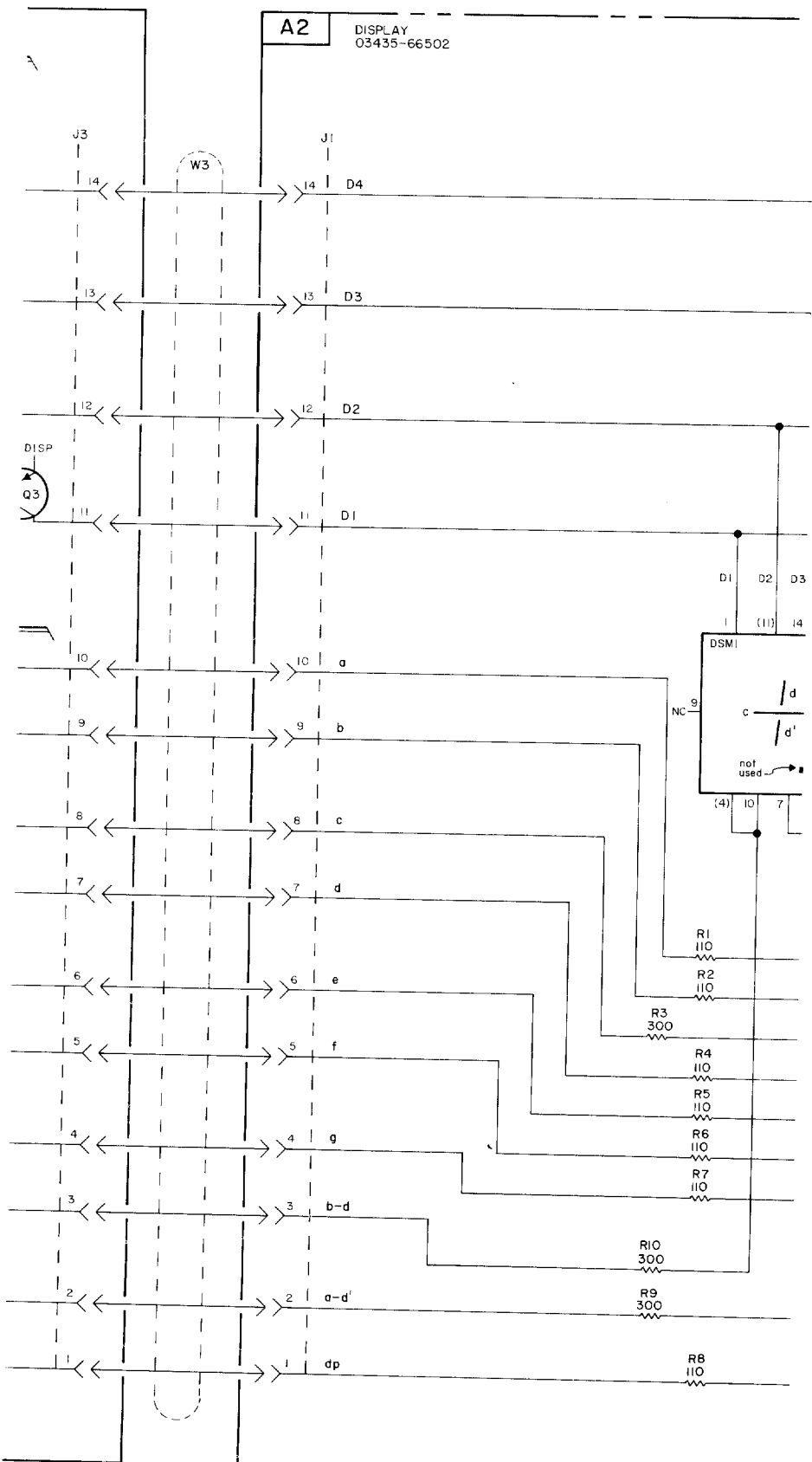

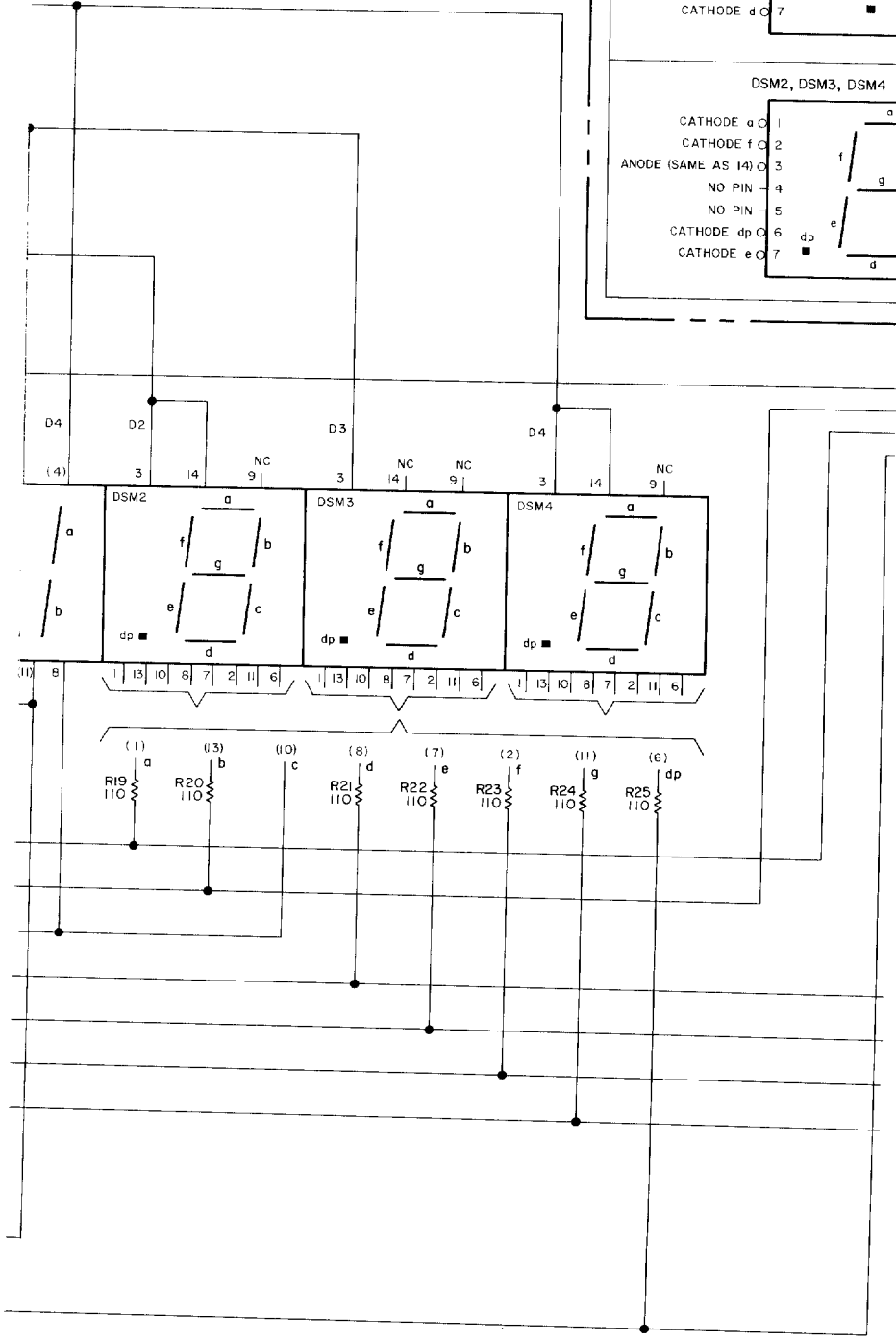
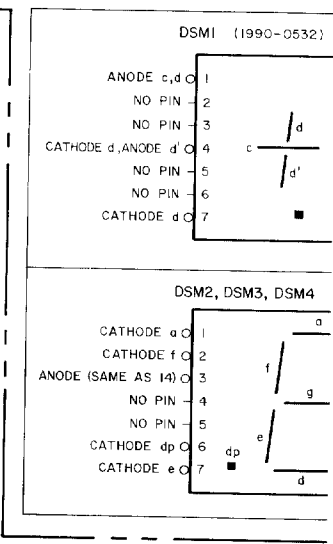

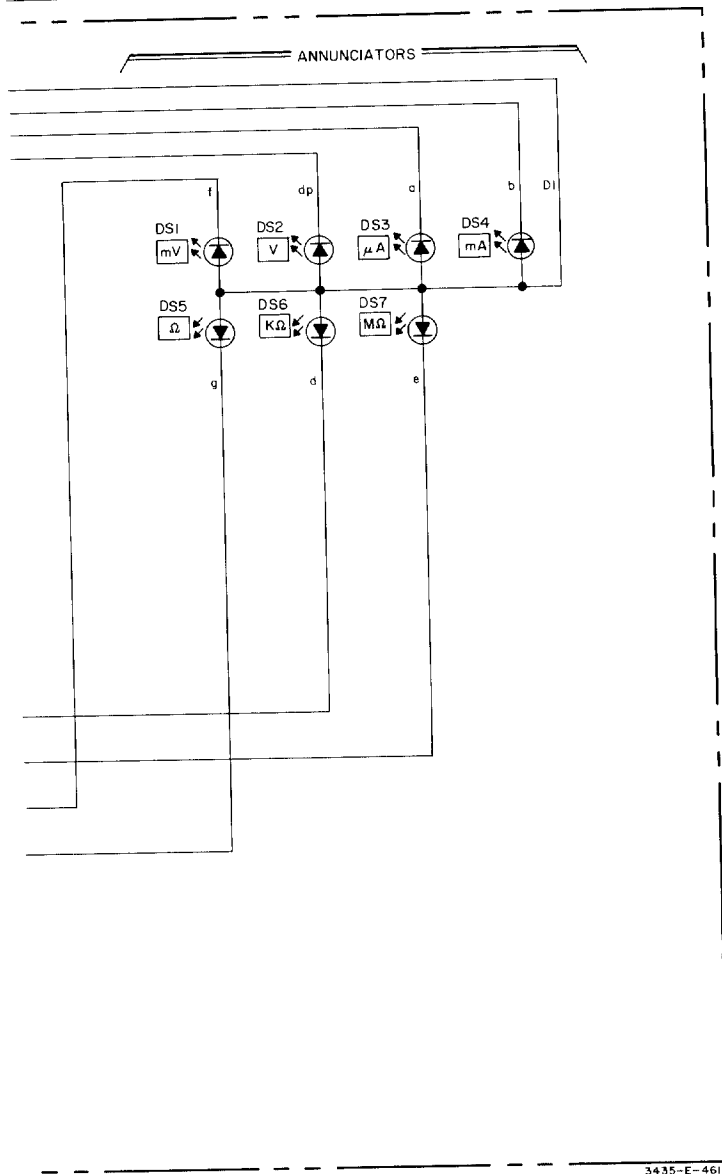
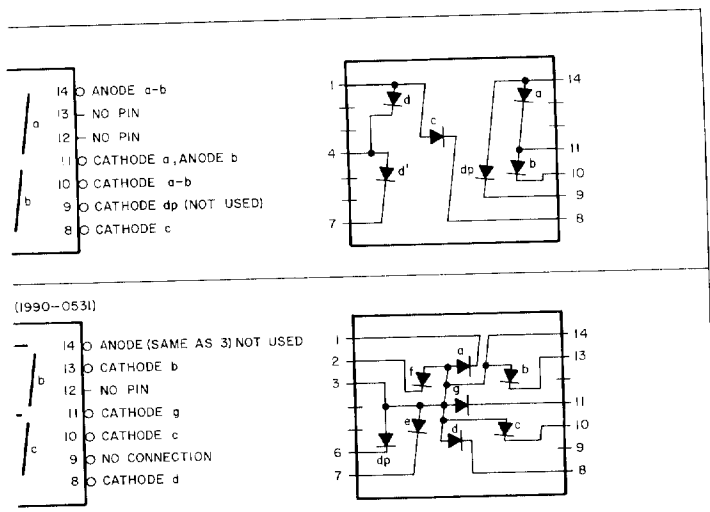

3

Figure 7-7. Display Schematic.  
7-13

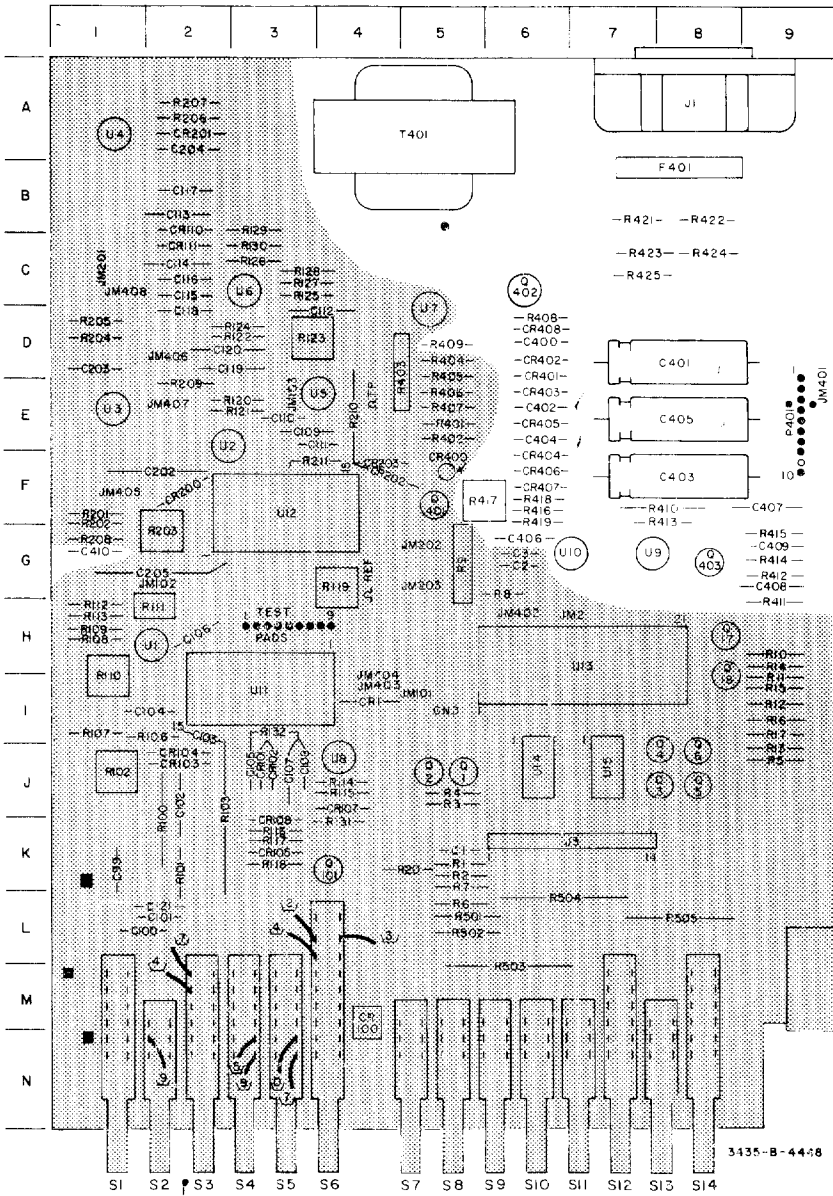

A1 COMPONENT LOCATIONS

|     | C  | CR | R  |
|-----|----|----|----|
| 400 | D6 |    |    |
| 401 |    | E6 |    |
| 402 | E6 | D6 |    |
| 403 |    | E6 |    |
| 404 | E6 | F6 |    |
| 405 |    | E6 |    |
| 406 | G6 | F6 |    |
| 407 | F9 | F6 |    |
| 408 | G9 | D6 | D6 |
| 409 | G9 |    | D5 |
| 410 | G1 |    | F8 |
| 411 |    |    | H9 |
| 412 |    |    | G9 |
| 413 |    |    | F8 |
| 414 |    |    | G9 |
| 415 |    |    | G9 |
| 416 |    |    | F6 |
| 417 |    |    | F5 |
| 418 |    |    | F6 |
| 419 |    |    | F6 |
| 421 |    |    | B7 |
| 422 |    |    | B8 |
| 423 |    |    | C7 |
| 424 |    |    | C8 |
| 425 |    |    | C7 |

UNSHADED AREAS  
FOR THIS SCHEMATIC

A1  
-hp- Part No. 03435-66501





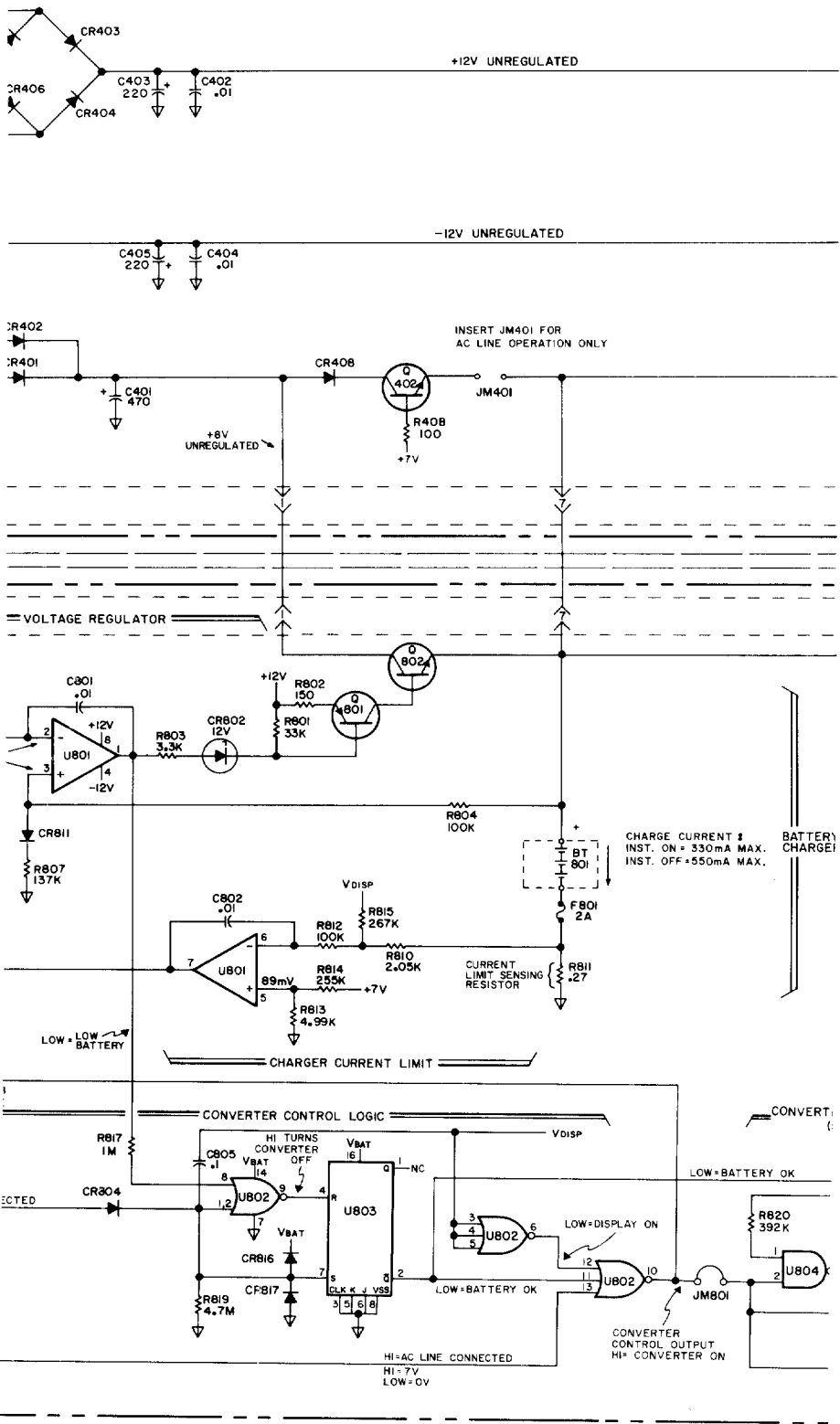

+12V UNREGULATED

-12V UNREGULATED

+8V UNREGULATED

VOLTAGE REGULATOR

CHARGE CURRENT 1  
INST. ON = 330mA MAX.  
INST. OFF = 550mA MAX.

BATTERY CHARGE

CURRENT LIMIT SENSING RESISTOR

LOW + LOW BATTERY

CHARGER CURRENT LIMIT

CONVERTER CONTROL LOGIC

CONVERTER CONTROL OUTPUT HI= CONVERTER ON

LOW-BATTERY OK

HI-AC LINE CONNECTED  
HI = 7V  
LOW = 0V



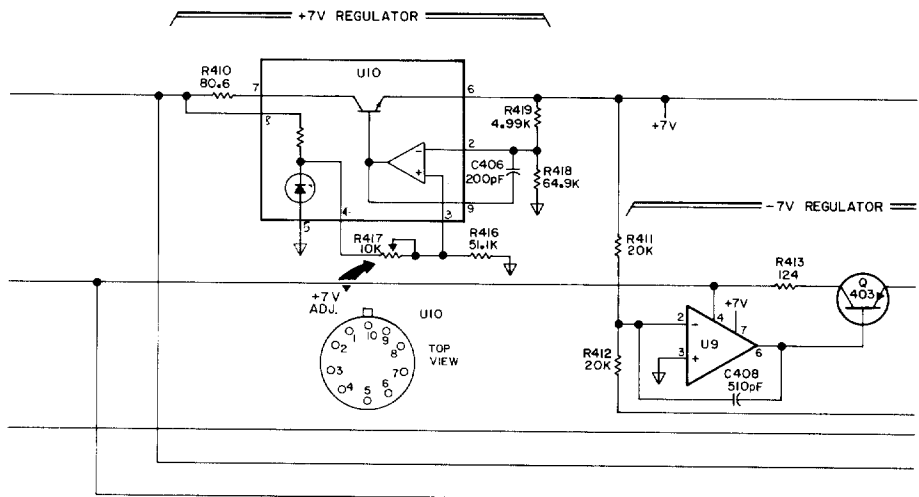

VBAT  
SEE NOTE 1

NOTE 1  
BATTERY VOLTAGE (VBAT) WILL VARY BETWEEN +5.6V AND +6.5V DEPENDING ON CHARGE STATUS OF THE BATTERY. THE DISPLAY VOLTAGE (VDIS) EQUALS VBAT WHEN SI IS ON AND AC LINE IS DISCONNECTED.

NOTE 2  
U802, U803, AND U804 ARE CMOS IC'S LOGIC HI=7V±2V AND LOGIC LOW=0V±1V.

NOTE 3  
U801 PINS 2 AND 3 BATTERY OPERATION = 3.4V. AC LINE OPERATION = 4.3V.

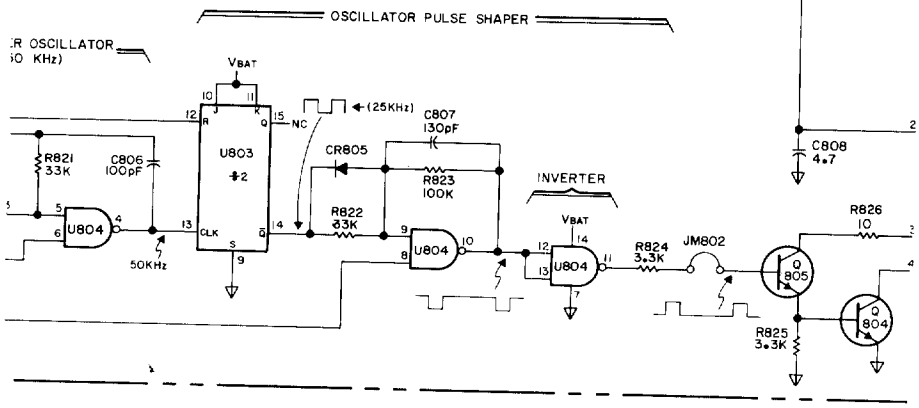



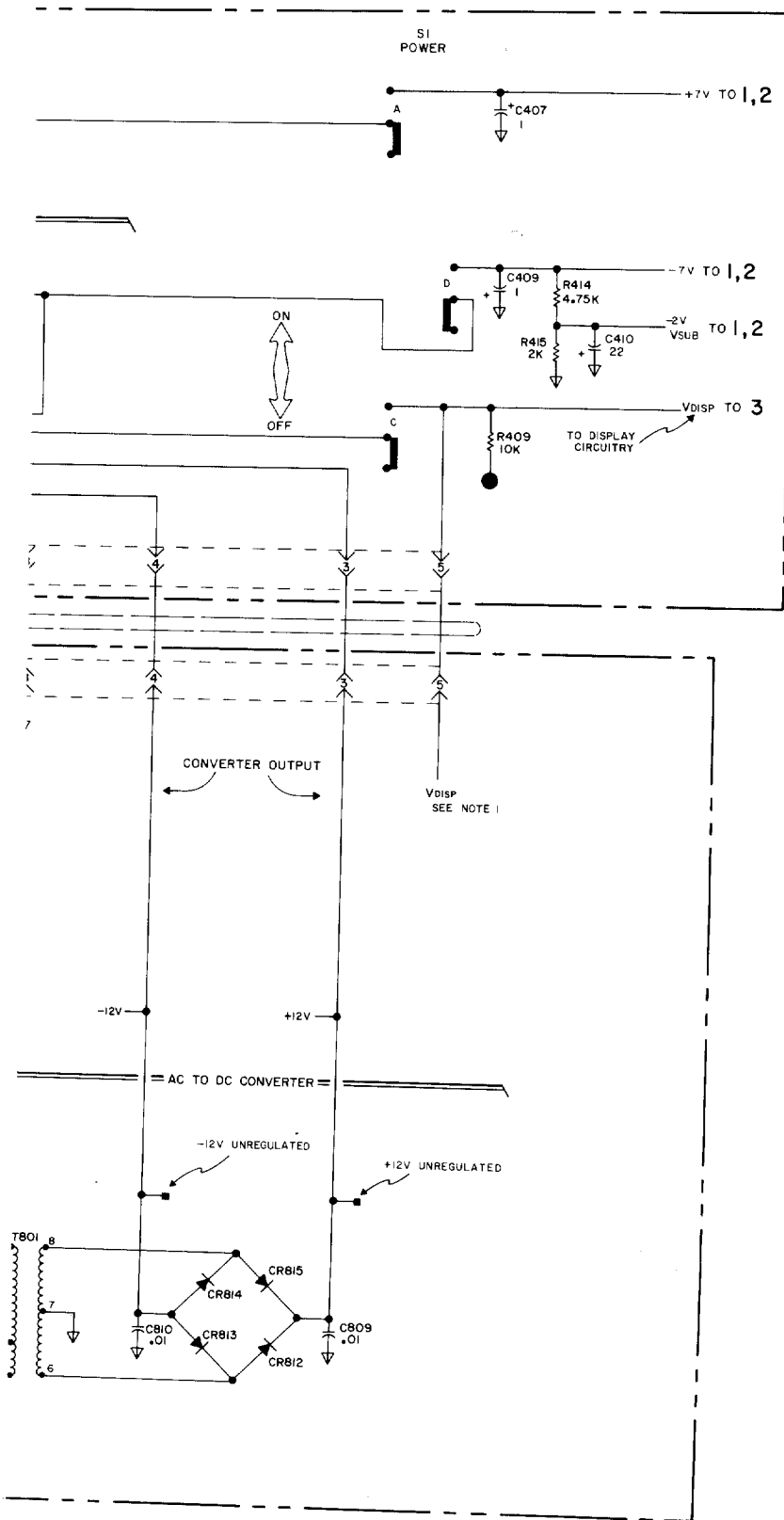

4

Figure 7-8. Power Supply and Battery Charger Schematic .  
7-15/7-16

