

Agilent Technologies 4073A Ultra Advanced Parametric Tester

System Specification - Revision 2.0

November 2000



Agilent Technologies
Innovating the HP Way

1. GENERAL DESCRIPTION

The Agilent Technologies 4073A Ultra Advanced Parametric Tester is the 4070 family's new flagship product and designed to perform outstanding precise/fast DC measurement as well as capacitance measurement, Flash memory cell testing, and other high-frequency applications. The system supports up to eight Source Monitor Units (SMUs). Each SMU is self-calibrating, and may be individually configured to force either current or voltage and simultaneously measure either voltage or current.

External instruments can be integrated into the system via the eight auxiliary input ports or 48 extended path input. The 48 extended path inputs allow the user to connect external signals directly to the DUT pins. A low-leakage switching matrix connects all of the inputs to fully guarded Kelvin output pins, customizable from 12 to 48 output pins. One special additional pin is dedicated as a chuck connection.

In addition, the 4073A has a high frequency switching matrix with integrated pulse generator control. The high frequency matrix is organized as two 3×24 matrices (6 inputs total), and furnished 1 TO 2 connectors may be used on each matrix pair to create one 3×48 matrix (3 inputs total). The system also has one 1.6 A ground unit.

Measurement Functions:

DC Current, DC Voltage, Capacitance and Conductance, Differential voltage, Pulse force

DC Measurements:

Spot, Sweep, Pulse, and Pulse Sweep
Measurement subsystem:

HRSMU (High Resolution SMU),
MPSMU (Medium Power SMU) and
HPSMU (High Power SMU)

Measurement range:

1 fA^*1 to 100 mA, $2 \text{ }\mu\text{V}$ to 100 V
(using the 2 low current SMU ports)
 100 fA to 1 A^{*2} , $2 \text{ }\mu\text{V}$ to 200 V^{*2}
(using the 6 standard SMU ports)

*1: Using optional HRSMU. Using MPSMU, 10
fA to 100 mA, $2 \text{ }\mu\text{V}$ to 100

*2: Using optional HPSMU. Using MPSMU,
100 fA to 100 mA, $2 \text{ }\mu\text{V}$ to 100 V

C/G Measurement: C/G, C/G-V

Measurement subsystem:

4284A

Test Frequencies:

1 KHz, 10 KHz, 100 KHz, 1 MHz

Measurement range:

1 fF to 100 nF, 0.1 nS to 7.5 mS

DC Bias Voltage: $\pm 40 \text{ V}$

Two terminal differential voltage

Measurement:

Measurement subsystem:

3458A

Measurement range:

$0.1 \text{ }\mu\text{V}$ to 100 V

High Frequency Pulse Force:

Supported pulse generators:

81110A (or 8110A) and 8114A

Maximum number of installable pulse generators:

$5 \times 81110\text{A}$ or 8110A

(without 8114A)

$4 \times 81110\text{A}$ or 8110A

(with $1 \times 8114\text{A}$)

$2 \times 81110\text{A}$ or 8110A

(with $2 \times 8114\text{A}$)

Pulse level (at open load):

$\pm 19\text{V}$ (81110A or 8110A), -49.9 V to
 $+ 50 \text{ V}$ (8114A)

Pulse period:

350 ns to 999 s (81110A or 8110A),

350 ns to 999 ms (8114A)

Pulse width:

50 ns to 999 ms (81110A or 8110A),

150 ns to 150 ms (8114A)

Pulse delay: 0 s to 998 ms

Transition time:

20 ns to 200 ms (81110A or 8110A),

65 ns (8114A)

Switching Matrix Measurement

Pins:

Between 12 and 48 pins (Note: One additional pin is dedicated for the prober chuck connection)

Switching Matrix Instrument Ports:

Up to 8 SMUs and one ground unit

8 auxiliary (AUX) ports

6 high frequency (HF) ports

48 extended paths

Pulse switch input / output ports

2. SWITCHING MATRIX SUBSYSTEM

Maximum DUT Pins:

48 output pins + 1 pin for prober chuck connection (triax connector)
 Only E3122A (High Resolution pin board) can be used for 4073A (Can't use E3121A)

Maximum number of Instrument Ports:

SMU Port in Test Head:
 8 SMU + 1 GNDU
 2 ports for low-current measurement (Non-Kelvin)
 4 ports (Kelvin)
 2 ports (Non-Kelvin)
 1 port for GNDU (Kelvin)

Auxiliary port:
 8 for external instruments (C-meter, Digital voltmeter, etc.)
 2 triaxial input ports (Force/Guard/Common, aux input ports 1 and 2)
 4 BNC two-pair input ports (Force/Common and Sense/Common, aux input ports 3 to 6)
 2 BNC input ports (Force/Common, aux input ports 7 and 8)

High frequency (HF) port:
 6 for pulse generator (81110A, 8110A or 8114A) or other external instruments.

HF ports 1 through 3 can access measurement pins 1 through 24, and HF ports 4 through 6 can access measurement pins 25 through 48 pins. The user has the option of connecting any of the following HF port pairs together via a 1 TO 2 ADAPTOR in order to access all (1 through 48) measurement pins: ports 1 and 4, ports 2 and 5, and ports 3 and 6.

Extended path:
 48 extended paths - The system provides one on/off relay for each path.

Pulse switch input/output ports:
 Please refer to the next section.

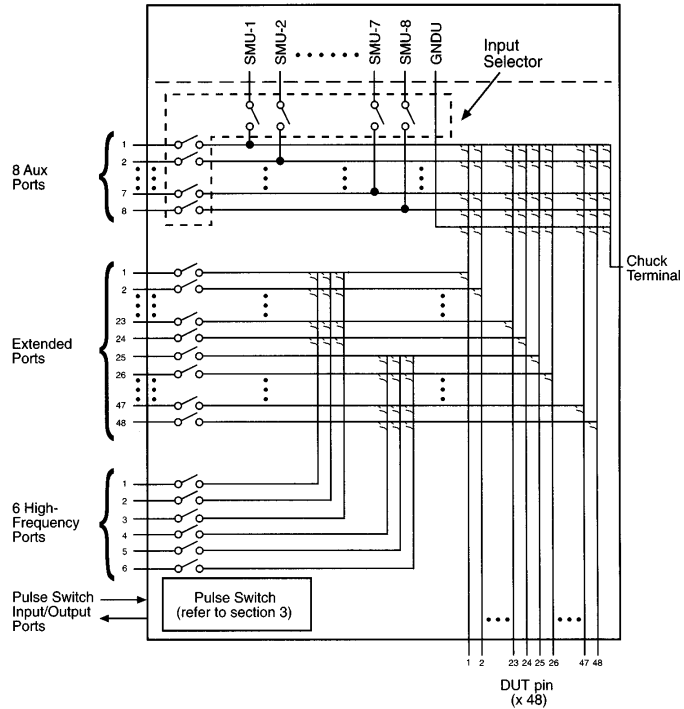

Test Head Circuit Diagram

Maximum Voltage at Each Port:

SMU port in Test Head: ± 200 V
 Auxiliary port: ± 200 V (port 1, and 2)
 ± 100 V (ports 3 to 8)

High frequency port:
 ± 100 V (between force and common of each HF port)
 ± 100 V (between two of forces of all HF ports)
 ± 100 V (between any force of HF ports and any force of extended paths)

Extended path:
 ± 100 V (between force and common of each extended path)
 ± 100 V (between any force of HF ports and any force of extended paths)

Maximum Current, Port to DUT Pin:

SMU port in Test Head: ± 1.0 A
 GNDU: ± 1.6 A
 Auxiliary port: ± 1.0 A
 High frequency port: ± 0.5 A
 Extended path: ± 0.5 A

Maximum Residual Resistance: through auxiliary port

Low current port: Force 1.0Ω
 Kelvin port: Force 1.0Ω
 Sense 2.5Ω
 Non-Kelvin: Force 1.0Ω

through high frequency port (supplemental characteristics): 2.0Ω

Maximum Stray Capacitance between DUT Pins (supplemental characteristics): 3 pF (between C meter ports)

Isolation Resistance (supplemental characteristics): Low Current (with Guard): $1 \times 10^{15} \Omega$

HF port bandwidth (@-3dB) (supplemental characteristics): 60 MHz (50Ω load impedance: from port to DUT pin, 3×24 configuration)

HF port cross talk between pins (supplemental characteristics): $\pm 2 \%$ ($5 \text{ k}\Omega$ load impedance: from port to DUT pin, 20 ns pulse transition time)

3. PULSE SWITCH

The pulse switch includes seven semiconductor switching relays, for reliable and direct control of pulse shaping by the pulse generator or CPU. The pulse switch is integrated into 4073A test head.

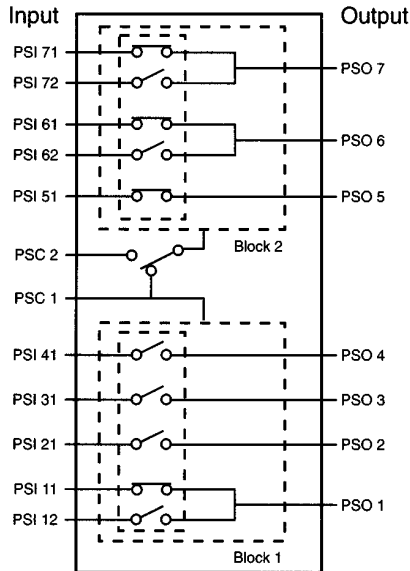

Pulse Switch

Number of blocks: 2

Number of switch of each block:

Block 1:

3 relays (make or break, selectable type) and 1 relay (transfer type to create multi-level pulse)

Block 2:

1 relay (make or break, selectable type) and 2 relays (transfer type to create multi-level pulse)

Control input port:

One input per each block (PSC1 and PSC2)

Control Method:

Both the PG and CPU can control all switches. PG or CPU control is independent for every block. In the case of PG control, block 1 can be controlled by the PSC1 input, and block 2 can be controlled by either PSC1 or PSC2 (selectable).

Mode of relay control:

Make or break, selectable type relay:

Normally open or Normally closed modes are selectable

Transfer type relay:

Normally open and Normally closed modes are not selectable

Maximum Voltage:

±60 V (between force and common of each switch)

±60 V (between PSI 21 and PSO 2, between PSI 31 and PSO 3, between PSI 41 and PSO 4, between PSI 51 and PSO 5)

±60 V (between PSI 11 (or PSI 12) and PSO 1, between PSI 11 and PSI 12, between PSI 61 (or PSI 62) and PSO 6, between PSI 61 and PSI 62, between PSI 71 (or PSI 72) and PSO 7, between PSI 71 and PSI 72)

Maximum Current:

±0.4 A (from input to output)

Residual resistance

(supplemental characteristics):

Nominal 2 Ω (from IN to OUT)

OFF capacitance

(supplemental characteristics):

80 pF (between IN and OUT: Vin-Vout = 0 V)

100 pF (force <-> common @ output of make or break, selectable type relay: Vin-Vout = 0 V)

Operating time of switching

(supplemental characteristics):

max. 2 ms

4. DC MEASUREMENT SUBSYSTEM

4.1 SMU (Source and Monitor Unit)

4.1.1 Voltage Source/Monitor Range, Resolution, and Accuracy

When using Low-Current Port-1 and Port-2 and HRSMU:

Full Scale Voltage Range	Resolution Force	Resolution Measure	Resolution Precision ADC	Force Accuracy \pm (%reading + %range + volt)	Measure Accuracy \pm (%reading + %range + volt)
± 2 V	100 μ V	100 μ V	2 μ V	$0.03\% + 0.035\% + (R_{mat} \times I_o)$	$0.02\% + 0.025\% + (R_{mat} \times I_o)$
± 20 V	1 mV	1 mV	20 μ V	$0.03\% + 0.02\% + (R_{mat} \times I_o)$	$0.02\% + 0.015\% + (R_{mat} \times I_o)$
± 40 V	2 mV	2 mV	40 μ V		
± 100 V	5 mV	5 mV	100 μ V		

When using MPSMU and HPSMU:

Full Scale Voltage Range	Resolution Force	Resolution Measure	Resolution Precision ADC	Force Accuracy \pm (%reading + %range + volt)	Measure Accuracy \pm (%reading + %range + volt)
± 2 V	100 μ V	100 μ V	2 μ V	$0.05\% + 0.05\% + (R_{mat} \times I_o)$	$0.04\% + 0.04\% + (R_{mat} \times I_o)$
± 20 V	1 mV	1 mV	20 μ V		
± 40 V	2 mV	2 mV	40 μ V		
± 100 V	5 mV	5 mV	100 μ V		
± 200 V ^{*1}	10 mV	10 mV	100 μ V		$0.045\% + 0.04\% + (R_{mat} \times I_o)$

*1: Using HPSMU

I_o = Output Current

R_{mat} = Residual Resistance of Matrix Port Force

Note: R_{mat} is different at each port.

Low Current Port (port-1, port-2): 1.0 Ω

Kelvin Port: 3 m Ω

Non-Kelvin Port (port-7, port-8): 1.0 Ω

When using prober chuck connection pin, add 0.1 Ω to R_{mat}

4.1.2 Current Source/Monitor Range, Resolution, and Accuracy

When using Low-Current Port-1 and Port-2 and HPSMU:

Full-scale Current Range	Resolution Force	Resolution Measure	Resolution Precision ADC	Force Accuracy ± (%reading + %range + amp)	Measure Accuracy ± (%reading + %range + amp)
±100 mA	5 µA	5 µA	100 nA	0.12% + [0.05 + (0.0001 × Vo)]%	0.1% + [0.04 + (0.0001 × Vo)]%
±10 mA	500 nA	500 nA	10 nA	0.06% + [0.04 + (0.0001 × Vo)]%	0.06% + [0.03 + (0.0001 × Vo)]%
±1 mA	50 nA	50 nA	1 nA	0.06% + [0.05 + (0.0001 × Vo)]%	0.06% + [0.04 + (0.0001 × Vo)]%
±100 µA	5 nA	5 nA	100 pA	0.07% + [0.04 + (0.0001 × Vo)]%	0.06% + [0.035 + (0.0001 × Vo)]%
±10 µA	500 pA	500 pA	10 pA	0.07% + [0.05 + (0.0001 × Vo)]%	0.06% + [0.04 + (0.0001 × Vo)]%
±1 µA	50 pA	50 pA	1 pA	0.12% + [0.04 + (0.0001 × Vo)]%	0.12% + [0.035 + (0.0001 × Vo)]%
±100 nA	5 pA	5 pA	100 fA	0.12% + [0.05 + (0.0001 × Vo)]% + (1 fA/V × Vo)	0.12% + [0.04 + (0.0001 × Vo)]% + (1 fA/V × Vo)
±10 nA	500 fA	500 fA	10 fA	1% + [0.05 + (0.0001 × Vo)]% + 3 pA + (1 fA/V × Vo)	1% + [0.04 + (0.0001 × Vo)]% + 3 pA + (1 fA/V × Vo)
±1 nA	50 fA	50 fA	10 fA	1% + [0.07 + (0.0001 × Vo)]% + 3 pA + (1 fA/V × Vo)	1% + [0.04 + (0.0001 × Vo)]% + 3 pA + (1 fA/V × Vo)
±100 pA	5 fA	5 fA	2 fA	4% + [0.4 + (0.0001 × Vo)]% + 500 fA + (1 fA/V × Vo)	4% + [0.12 + (0.0001 × Vo)]% + 500 fA + (1 fA/V × Vo)
±10 pA	1 fA	2 fA	1 fA	4% + [4.0 + (0.0001 × Vo)]% + 500 fA + (1 fA/V × Vo)	4% + [1.0 + (0.0001 × Vo)]% + 500 fA + (1 fA/V × Vo)

Note: The HPSMU cannot be connected to ports 1 or 2

When using Low-Current Port-1 and Port-2 and MPSMU:

Full Scale Current Range	Resolution Force	Resolution Measure	Resolution Precision ADC	Force Accuracy ± (%reading + %range + amp)	Measure Accuracy ± (%reading + %range + amp)
±100 mA	5 µA	5 µA	100 nA	0.12% + [0.1 + (0.0005 × Vo)]%	0.1% + [0.05 + (0.0005 × Vo)]%
±10 mA	500 nA	500 nA	10 nA		
±1 mA	50 nA	50 nA	1 nA		
±100 µA	5 nA	5 nA	100 pA		
±10 µA	500 pA	500 pA	10 pA	0.2% + [0.1 + (0.0005 × Vo)]% + (2 pA/100V × Vo)	0.2% + [0.05 + (0.0005 × Vo)]% + (2 pA/100V × Vo)
±1 µA	50 pA	50 pA	1 pA		
±100 nA	5 pA	5 pA	100 fA		
±10 nA	500 fA	500 fA	10 fA	1% + [0.1 + (0.0005 × Vo)]% + 3 pA + (2 pA/100V × Vo)	1% + [0.1 + (0.0005 × Vo)]% + 3 pA + (2 pA/100V × Vo)
±1 nA	50 fA	50 fA	10 fA		

Note: The HPSMU cannot be connected to ports 1 or 2

When using Standard Port-3 through Port-8:

Full Scale Current Range	Resolution Force	Resolution Measure	Resolution Precision ADC	Force Accuracy ± (%reading + %range + amp)	Measure Accuracy ± (%reading + %range + amp)
±1 A*1	50 µA	50 µA	1 µA	0.5% + [0.1 + (0.0005 × Vo)]%	0.5% + [0.05 + (0.0005 × Vo)]%
±100 mA	5 µA	5 µA	100 nA	0.12% + [0.1 + (0.0005 × Vo)]%	0.1% + [0.05 + (0.0005 × Vo)]%
±10 mA	500 nA	500 nA	10 nA		
±1 mA	50 nA	50 nA	1 nA		
±100 µA	5 nA	5 nA	100 pA		
±10 µA	500 pA	500 pA	10 pA		
±1 µA	50 pA	50 pA	1 pA	0.2% + [0.1 + (0.0005 × Vo)]% + (300 pA + 1000 pA/100V × Vo)	0.2% + [0.05 + (0.0005 × Vo)]% + (300 pA + 1000 pA/100V × Vo)
±100 nA	5 pA	5 pA	100 fA	1% + [0.1 + (0.0005 × Vo)]% + 3 pA + (300 pA + 1000 pA/100V × Vo)	1% + [0.1 + (0.0005 × Vo)]% + 3 pA + (300 pA + 1000 pA/100V × Vo)
±10 nA**	500 fA	500 fA	10 fA		
±1 nA**	50 fA	50 fA	10 fA		

Note: The HPSMU can be connected only to ports 3 and 4.

*1: Using HPSMU

** Supplemental characteristics when using Port-3 to Port-8

Maximum Output Voltage/Current:

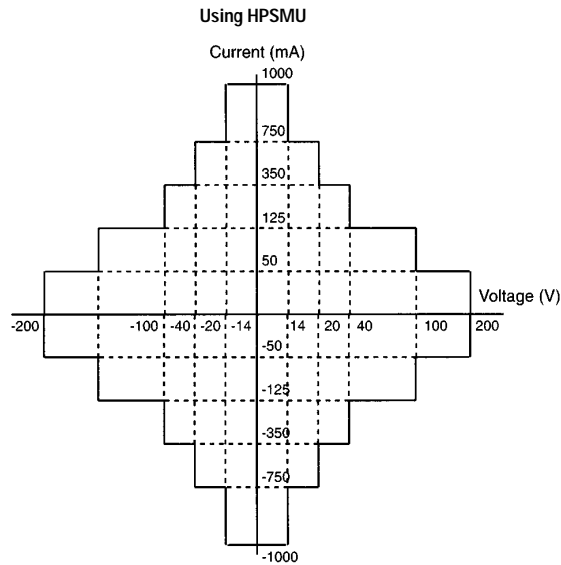
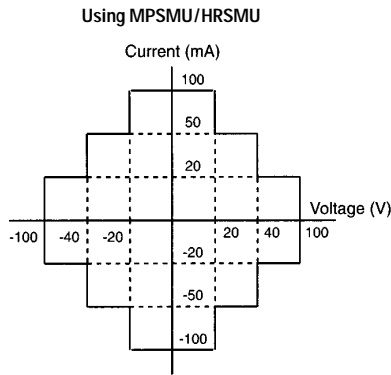

Over Current Range:

15% of range (0% for 100 mA range of MPSMU/HRSMU, 0% for 1 A range of HPSMU, 5% for 10 pA/100 pA range of HRSMU)

Over Voltage Range:

(V Force): 0% of range
 (V Measure): 10% of range
 (0% for 100 V range of MPSMU/HRSMU, 0% for 200 V range of HPSMU)

Current Compliance Setting Range:

1 pA to maximum current

In the following section,

Accuracy of converse polar current limit**:
 ±2% of range (100 nA to 1 A ranges)
 ±10% of range (10 pA to 10 nA ranges)

Maximum Capacitive Load:

≤ 1000pF
 Maximum Allowable Guard Capacitance:
 250 pF (between signal line and guard line outside of the matrix)
 Maximum Slew Rate: 0.2 V/µs

** Supplemental Characteristics

4.1.3 SMU configuration

Minimum configuration: 1 HRSMU and 2 MPSMUs (default configuration)

A maximum of 2 HRSMUs can be installed and can only be connected to ports 1 and 2. And a maximum of 2 HPSMUs can be installed and can only be connected to ports 3 and 4. The first HPSMU must be connected to port 3, and the second to port 4. The default configuration of the Agilent 4073A has 1 HRSMU (connected to port 2) and 2 MPSMUs (connected to ports 3 and 4). The following tables indicate the installation order for additional MPSMUs.

(1 HRSMU and no HPSMU are installed)

Port Number	Installed SMU	Installation order for additional SMUs
1	MPSMU	2
2	HRSMU	Default
3	MPSMU	Default
4	MPSMU	Default
5	MPSMU	1
6	MPSMU	3
7	MPSMU	4
8	MPSMU	5

(2 HRSMUs and no HPSMU are installed)

Port Number	Installed SMU	Installation order for additional SMUs
1	HRSMU	Optional HRSMU
2	HRSMU	Default
3	MPSMU	Default
4	MPSMU	Default
5	MPSMU	1
6	MPSMU	2
7	MPSMU	3
8	MPSMU	4

(1 HRSMU and 1 HPSMU are installed)

Port Number	Installed SMU	Installation order for additional SMUs
1	MPSMU	1
2	HRSMU	Default
3	HPSMU	Optional HPSMU
4	MPSMU	Default
5	MPSMU	Default
6	MPSMU	2
7	MPSMU	3
8	MPSMU	4

(2 HRSMUs and 1 HPSMU are installed)

Port Number	Installed SMU	Installation order for additional SMUs
1	HRSMU	Optional HRSMU
2	HRSMU	Default
3	HPSMU	Optional HPSMU
4	MPSMU	Default
5	MPSMU	Default
6	MPSMU	1
8	MPSMU	2

(1 HRSMU and 2 HPSMUs are installed)

Port Number	Installed SMU	Installation order for additional SMUs
1	MPSMU	Default
2	HRSMU	Default
3	HPSMU	Optional HPSMU
4	HPSMU	Optional HPSMU
5	MPSMU	Default
6	MPSMU	1
7	MPSMU	2

(2 HRSMUs and 2 HPSMUs are installed)

Port Number	Installed SMU	Installation order for additional SMUs
1	HRSMU	Optional HRSMU
2	HRSMU	Default
3	HPSMU	Optional HPSMU
4	HPSMU	Optional HPSMU
5	MPSMU	Default
6	MPSMU	Default

4.2 Ground Unit (GNDU)

This unit is used for ground when making measurements.

Output Voltage: 0 V
 Maximum current: ± 1.6 A
 Offset Voltage: ± 200 μ V
 Maximum Capacitance Load: 1 μ F**

** Supplemental Characteristics

4.3 Digital Volt Meter (Agilent 3458A)

Voltage Measurement Range, Resolution, and Accuracy

Full Scale Voltage Range	Resolution	Accuracy (% of reading + volt)
0.1 V	0.1 μ V	0.01% + 100 μ V
1 V	1 μ V	0.01% + 100 μ V
10 V	10 μ V	0.01% + 200 μ V
100 V	100 μ V	0.02% + 1 mV

at NPCL ≥ 1

5. CAPACITANCE MEASUREMENT

Accuracy is specified between any two output pins except chuck connection pin.

Measurement range:

1 fF to 1.2 nF and 10 nS to 7.5 mS (1MHz)

1 fF to 10 nF and 1 nS to 6.3 mS (100KHz)

1 fF to 100 nF and 0.1 nS to 6.3 mS (10KHz)

10 fF to 100 nF and 0.1 nS to 0.63 mS (1KHz)

Measurement frequency:

1 KHz, 10 KHz, 100 KHz, and 1MHz

DC Bias Voltage: $\pm 40V$

Measurement speed:

MEDIUM or LONG

Note: Above specifications are valid after calibration data measurement and offset cancel.

DC Bias Range and Accuracy

Full Scale Voltage Range	Force Accuracy \pm (%reading + %range + volt)
$\pm 40 V$	0.1% + 10 mV

Accuracy is specified between CMH and CML pins.

Test signal level: 30 mV (rms)

Bias Current Isolation Function: OFF

C/G Measurement Range, Resolution, and Accuracy

Frequency	C Range	C Accuracy % of reading + % of range	G Range	G Accuracy % of reading + % of range
1 MHz	10 pF**	$0.8\% + [1.0 + (0.6 \times Gm/63 \mu S)]\%$	63 μS	$0.8\% + [1.0 + (0.6 \times Cm/10 pF)]\%$
	100 pF	$0.8\% + [0.3 + (0.6 \times Gm/630 \mu S)]\%$	630 μS	$0.8\% + [0.3 + (0.6 \times Cm/100 pF)]\%$
	1 nF	$1.5\% + [0.2 + (1.7 \times Gm/6.3 mS)]\%$	6.3 mS	$1.3\% + [0.2 + (2.2 \times Cm/1 nF)]\%$
100 KHz	10 pF**	$0.4\% + [1.0 + (0.3 \times Gm/6.3 \mu S)]\%$	6.3 μS	$0.4\% + [1.0 + (0.4 \times Cm/10 pF)]\%$
	100 pF	$0.3\% + [0.3 + (0.3 \times Gm/63 \mu S)]\%$	63 μS	$0.3\% + [0.3 + (0.3 \times Cm/100 pF)]\%$
	1 nF	$0.3\% + [0.2 + (0.4 \times Gm/630 \mu S)]\%$	630 μS	$0.3\% + [0.2 + (0.4 \times Cm/1 nF)]\%$
	10 nF	$0.5\% + [0.2 + 1.0 \times (Gm/6.3 mS)]\%$	6.3 mS	$0.7\% + [0.2 + (0.8 \times Cm/10 nF)]\%$
10 KHz	100 pF	$0.3\% + [0.2 + (0.3 \times Gm/6.3 \mu S)]\%$	6.3 μS	$0.3\% + [0.2 + (0.3 \times Cm/100 pF)]\%$
	1 nF	$0.3\% + [0.1 + (0.3 \times Gm/63 \mu S)]\%$	63 μS	$0.3\% + [0.1 + (0.3 \times Cm/1 nF)]\%$
	10 nF	$0.3\% + [0.1 + (0.3 \times Gm/630 \mu S)]\%$	630 μS	$0.3\% + [0.1 + (0.3 \times Cm/10 nF)]\%$
	100 nF	$0.3\% + [0.1 + (1.0 \times Gm/6.3 mS)]\%$	6.3 mS	$0.7\% + [0.1 + (0.7 \times Cm/100 nF)]\%$
1 KHz	100 pF**	$0.4\% + [0.5 + (0.4 \times Gm/0.63 \mu S)]\%$	0.63 μS	$0.4\% + [0.5 + (0.4 \times Cm/100 pF)]\%$
	1 nF	$0.3\% + [0.1 + (0.3 \times Gm/6.3 \mu S)]\%$	6.3 μS	$0.3\% + [0.1 + (0.3 \times Cm/1 nF)]\%$
	10 nF	$0.3\% + [0.1 + (0.3 \times Gm/63 \mu S)]\%$	63 μS	$0.3\% + [0.1 + (0.3 \times Cm/10 nF)]\%$
	100 nF	$0.3\% + [0.1 + (0.3 \times Gm/630 \mu S)]\%$	630 μS	$0.3\% + [0.1 + (0.3 \times Cm/100 nF)]\%$

Gm is measured conductance.

Cm is measured capacitance.

Accuracy is specified between any DUT pins.

Stray capacitance between force and guard must be under 5 pF.

Accuracy of frequency: $\pm 0.1\%$

Test signal level: 30 mVrms \pm 5mVrms

When measurement speed is set to SHORT, add 0.25% to % of reading and 0.1% to % of range.

When Open/Short calibration at DUT pins are carried out, accuracy is same as above table. (Note: The length of cable from output pins must be less than 1 meter and capacitance to guard must be under 100 pF.)

** Supplemental Characteristics

6. PULSE FORCE UNIT

Supported pulse generators:

81110A (or 8110A) and 8114A

Maximum number of installable pulse generators:

5 × 81110A or 8110A (without 8114A)

4 × 81110A or 8110A (with 1 × 8114A)

2 × 81110A or 8110A (with 2 × 8114A)

Pulse Force Mode

Pulse Signal:

2-level and 3-level output

Burst Count:

10⁹ (max.) or infinite

Output mode: Normal mode or

Pattern mode

Normal mode

All pulse generators (up to 5) can force synchronously

Pattern mode

All pulse generator except a master pulse generator can force synchronously (more accurate pulse width and pulse delay than normal mode)

Note: Agilent 8114A does not support pattern mode

Load impedance:

999 KΩ (default), selectable from 2.5 Ω to 999 KΩ (Agilent 81110A or 8110A)

999 KΩ (default), selectable from 10 Ω to 999 KΩ (Agilent 8114A)

Pulse Setting Range

Pulse period:

Normal mode

Range: 350 ns to 999 s, Resolution: 4 digits (min. 100 ps) (81110A or 8110A)

Range: 350 ns to 999 ms, Resolution: 3 digits (min. 1 ns) (8114A)

Pattern mode

Range: 120 us to 999 s, Resolution: 4 digits (min. 100 ns) (81110A or 8110A)

Range: 120 ns to 999 ms, Resolution: 3 digits (min. 1 us) (8114A)

Pulse width:

Normal mode

Range: 50 ns to 999 ms, Resolution: 3.5 digits (min. 50 ps) (81110A)

Range: 50 ns to 999 ms, Resolution: 3 digits (min. 100 ps) (8110A)

Range: 150 ns to 150 ms, Resolution: 3 digits (min. 1 ns) (8114A)

Pattern mode

Range: 50 ns to 999 ms (81110A or 8110A in a master unit)

150 ns to 150 ms (8114A)

100 ns to 999 ms (81110A or 8110A in a slave units)

Resolution:

3 digits (min. 100 ps) (81110A or 8110A in a master unit)

3 digits (min. 1 ns) (8114A)
81110A or 8110A in a slave units,
 1×10^{-n} (at $1000 \times 10^{-n} < T$
 $=< 4000 \times 10^{-n}$)

2×10^{-n} (at $4000 \times 10^{-n} < T$
 $=< 8000 \times 10^{-n}$)

2.5×10^{-n} (at $8000 \times 10^{-n} < T$
 $=< 10000 \times 10^{-n}$)

T means the maximum value of (pulse width + delay time) among all the channels. For example, if T is 250 us, then according to above table, the resolution is 0.1 us (1×10^{-7}) because $T = 250 \times 10^{-6} = 2500 \times 10^{-7}$.

Pulse delay:

Normal mode

Range: 0 to 998 ms, Resolution: 3.5 digits (min. 5 ps) (81110A)

Range: 0 to 998 ms, Resolution: 3 digits (min. 10 ps) (8110A)

Range: 0 to 998 ms, Resolution: 3 digits (min. 10 ns) (8114A)

Pattern mode

Range: 0 to 998 ms

Resolution:

3 digits (min. 10 ps) (in a master unit)

In a slave units,

1×10^{-n} (at $1000 \times 10^{-n} < T$
 $=< 4000 \times 10^{-n}$)

2×10^{-n} (at $4000 \times 10^{-n} < T$
 $=< 8000 \times 10^{-n}$)

2.5×10^{-n} (at $8000 \times 10^{-n} < T$
 $=< 10000 \times 10^{-n}$)

T means pulse period specified in the Force_pg subprogram. If not specified, T is the maximum value of $1.1 \times (\text{pulse width} + \text{delay time} + 30 \text{ ns})$ among all specified PGs.

Transition time:

20 ns to 200 ms (81110A or 8110A)

65 ns (fixed) (8114A)

Pulse level (at open load):

81110A or 8110A:

±19 V (at 2 level)

±19 V (at 3 level) Restriction for “3-level pulse with one PG” output mode: the sum of the absolute values of both amplitudes cannot exceed 20 V.

8114A:

-49.9 V to +50 V (at 2 level)

-49.9 V to +50 V (at 3 level)

There is no “3-level pulse with one PG” output mode on the Agilent 8114A because it has only one Output.

81110A (8110A) + 8114A:

-49.9 V to +50 V (at 3 level)

Pulse level accuracy (at open load):

81110A or 8110A level:

± ((2 % of amplitude) + 150 mV)

8114A amplitude:

± ((2 % of amplitude) + 200 mV)

8114A baseline:

± ((2 % of baseline) + (1 % of amplitude) + 200 mV)

Pulse shape accuracy (at 50 Ω load impedance):

81110A width:

\pm (3 % of setting + 2 ns) or
 \pm (0.5 % of setting + 2 ns)*
(in normal mode, width \geq 50 ns)

81110A delay:

\pm (3 % of setting + 1 ns)
 \pm (0.5 % of setting + 1 ns)*
(in normal mode, width \geq 50 ns)

8110A width:

\pm (5 % of setting + 2 ns)
(in normal mode, width \geq 50 ns)

8110A delay:

\pm (5 % of setting + 1 ns)
(in normal mode)

81110A or 8110A transition:

(-10 % of setting) to (+10 % of setting + 20 ns) (transition time \geq 20 ns)

81110A or 8110A overshoot:

\pm (5 % of amplitude + 20 mV)
(transition time \geq 20 ns)

*: Supplemental characteristics after timing calibration

8114A width:

\pm (5 % of setting + 3.5 ns)
(width \geq 200 ns)

\pm (5 % of setting + 6.0 ns)
(width \geq 150 ns)

8114A delay:

\pm (5 % of setting + 1 ns)

8114A transition:

65 ns \pm 20 ns

8114A overshoot:

\pm (5 % of amplitude + 50 mV)

Pulse shape accuracy (at 5 K Ω load impedance: reference data):

Agilent 81110A or 8110A overshoot/ringing:

\pm (5 % of amplitude + 20 mV)

8114A overshoot/ringing:

(-8% of amplitude) to (+4% of amplitude)

81110A or 8110A transition time: \pm

(10 % of setting + 5 ns)

8114A transition time:

56 ns \pm 5 ns

Skew between pins: \pm 10 ns

7. SYSTEM CONTROLLER

Supported Computers:

HP 9000 Series 700 Model 745/132L and 745I, HP Visualize workstation C 3600

Operating System:

HP-UX 10.20 (Needs some patches for Year 2000. Please contact your local sales representative)

HP BASIC/UX, SICL or C/ANSI C, SICL

Required Memory:

64MB is required (128MB is recommended)

Required Disk:

2GB is required (4GB recommended)

Required HP-IB Interfaces:

Agilent recommends two external GP-IB interface card for use with:

Instruments controlled by 4073A TIS commands (e.g. 4284A, 3458A)

Automatic Wafer Prober

8. SYSTEM SOFTWARE

Standard 4073A software provides the following capabilities:

System Management

Control of subsystems (TIS Library)

Parameter measurement utility (PARA Library)

Off-line debugging

Interactive Debugging Panel (IDP)

(includes Test Algorithm Code Generating Function)

Probing pattern generation and wafer maps display (PPG, MAP)

Prober Control Library (Sample program): Electroglas, TEL, and TSK

Application program (Sample program): flash memory cell evaluation, charge pumping method

Automatic Diagnostics

9. AGILENT SEMICONDUCTOR PROCESS EVALUATION CORE SOFTWARE (SPECS)

Agilent SPECS is a test shell environment for Agilent 4070 series.

Input:

User interaction occurs via a windows-based graphical interface with spreadsheet-like operation.

Test plans require only four simple specifications: wafer, die, test, and probe.

Customization:

Agilent supplies basic development, engineering, and operator test shell frameworks, which users can tailor or modify to create entirely new frameworks.

Analysis & Output:

All data is output into a flat ASCII file which users can manipulate to allow for input into database software. In addition, the data management structure supports x-y graphs, histograms, and wafer maps.

UNIX:

Users have full access to the UNIX environment from within the test shell.

10. GENERAL SPECIFICATIONS

Accuracy is specified at:

- Temperature: 23 ± 5°C
- Humidity: 5% to 70% RH*2
- Warm up: at least 40 min.
- Within one hour after Self-Calibration
- Integration Time: Medium or Long (16PLC or longer)*3

*2: 5% to 60% RH (no condensing) for current measure accuracy of HRSMU in 10 p to 100 nA range and isolation resistance of low current port

*3: Long integration time for current measure accuracy of HRSMU in less than 1 nA range

Note: The temperature changes after calibration must be less than 3°C.

Power Requirement:

Nominal Line Voltage*4	Allowable Voltage Range	Required Maximum Current
200 Vac	180 – 220 Vac	20A
208 Vac	188 – 228 Vac	24A
220 Vac	198 – 242 Vac	20A
240 Vac	216 – 252 Vac	20A

*4: Line frequency must be 48 to 63 Hz

Operating Temperature Range:
5°C to 35°C

Operating Humidity range: 5% to 70%

Storage Temperature Range:
–20°C to 50°C (< 80% RH, no condensation)*5

Warm up time (minimum): 40 minutes
Regulatory Compliance

- EMC: EMC Directive 89/336/EEC, 93/68/EEC
- Safety: Low Voltage Directive 73/23/EEC, 93/68/EEC
CSA 1010, CSA Certified
SEMI S2/93

Dimensions:

System Cabinet =
600mm (W) by 900mm (D) by
1600mm (H)

Test Head =
640mm (W) by 642mm (D) by
400mm (H)

Weight:

System Cabinet:

250 kg (including 4284A, 3458A, 4 × 81110A, 8114A and system controller)

Test Head:

75 kg (including 4 SMUs and 48 pins)

*5: In case of unpacked system, –20°C to 60°C (< 90% RH, <12 hrs)

11. RECOMMENDED CONDITION FOR LOW CURRENT AND VOLTAGE MEASUREMENT

In addition to conditions in GENERAL SPECIFICATIONS, Agilent Technologies recommends that the following conditions should be satisfied for measuring precise low current and low voltage with Agilent 4073A.

Note: These conditions are not specified to guarantee a certain measurement performance.

Auto prober*6: TEL P8LC, P12XL
TSK UF200, UF300

Probe card*6: JEM (Japan Electronic Materials Co.)

Temperature: Within ± 1°C after calibration

Temperature change period:
≥ 10 minutes

Humidity: ≤ 50%

Warm up time: ≥ 60 minutes

Floor vibration: ≤ 1mG

Floor vibration frequency: ≥10Hz

Air cleanliness: ≤ class 10,000

Line voltage: Burst noise ≤ 1kV

Surge noise ≤ 1kV
This line voltage environment applies
EN61326–1

*6: Please contact your local sales representative regarding latest information on recommended prober and probe card

Agilent Technologies' Test and Measurement Support, Services, and Assistance

Agilent Technologies aims to maximize the value you receive, while minimizing your risk and problems. We strive to ensure that you get the test and measurement capabilities you paid for and obtain the support you need. Our extensive support resources and services can help you choose the right Agilent products for your applications and apply them successfully. Every instrument and system we sell has a global warranty. Support is available for at least five years beyond the production life of the product. Two concepts underlie Agilent's overall support policy: "Our Promise" and "Your Advantage."

Our Promise

Our Promise means your Agilent test and measurement equipment will meet its advertised performance and functionality. When you are choosing new equipment, we will help you with product information, including realistic performance specifications and practical recommendations from experienced test engineers. When you use Agilent equipment, we can verify that it works properly, help with product operation, and provide basic measurement assistance for the use of specified capabilities, at no extra cost upon request. Many self-help tools are available.

Your Advantage

Your Advantage means that Agilent offers a wide range of additional expert test and measurement services, which you can purchase according to your unique technical and business needs. Solve problems efficiently and gain a competitive edge by contracting with us for calibration, extra-cost upgrades, out-of-warranty repairs, and on-site education and training, as well as design, system integration, project management, and other professional engineering services. Experienced Agilent engineers and technicians worldwide can help you maximize your productivity, optimize the return on investment of your Agilent instruments and systems, and obtain dependable measurement accuracy for the life of those products.

By internet, phone, or fax, get assistance with all your test & measurement needs

Online assistance:

www.agilent.com/find/assist

Phone or Fax

United States:
(tel) 1 800 452 4844

Canada:
(tel) 1 877 894 4414
(fax) (905) 206 4120

Japan:
(tel) (81) 426 56 7832
(fax) (81) 426 56 7840

Australia:
(tel) 1 800 629 485
(fax) (61 3) 9272 0749

Asia Pacific:
(tel) (852) 3197 7777
(fax) (852) 2506 9284

Europe:
(tel) (31 20) 547 2000

Latin America:
(tel) (305) 267 4245
(fax) (305) 267 4286

New Zealand:
(tel) 0 800 738 378
(fax) 64 4 495 8950

Product specifications and descriptions in this document subject to change without notice.

Copyright ©2000 Agilent Technologies
Printed in USA 11/00

