

---

# Service Guide

Publication Number D8064-97006  
September 2007

© Copyright Agilent Technologies 2005-2007  
All Rights Reserved.

---

## 8000 Series Infiniium Oscilloscopes

## **COPYRIGHT AND DISCLAIMER NOTICE**

Copyright – Agilent Technologies, Inc. Reproduced with the permission of Agilent Technologies Inc. Agilent Technologies, Inc. makes no warranty of any kind with regard to this material including, but not limited to, the implied warranties of merchantability and fitness for a particular purpose. Agilent Technologies, Inc. is not liable for errors contained herein or for incidental or consequential damages in connection with the furnishing, performance, or use of this material or data.

---

## The Agilent Infiniium Oscilloscope Model 8000 Series at a Glance

### Ease of use with high performance

The Agilent Technologies Infiniium oscilloscopes combine unprecedented ease-of-use with high-performance digitizing oscilloscope functionality to simplify your design and analysis measurement tasks.

- Traditional oscilloscope front-panel interface provides direct access to the controls needed for most troubleshooting tasks.
- Touchscreen graphical user interface with menus, windows, dialogs, and toolbars provides easy access to dozens of configuration and analysis tools, ensuring you can set up and make the most complex measurements.
- Agilent DSO8064A offers 4 channels, 4 GSa/s sampling rate in 2-channel mode, 2 GSa/s sampling rate in 4-channel mode, 600 MHz bandwidth. The MSO8064A also includes 16 digital channels.
- Agilent DSO8104A offers 4 channels, 4 GSa/s sampling rate in 2-channel mode, 2 GSa/s sampling rate in 4-channel mode, 1 GHz bandwidth. The MSO8104A also includes 16 digital channels.

### Display shows waveforms and graphical user interface

- Graphical interface allows direct interaction with waveforms, including drag-and-drop positioning and instant waveform zoom
- Touchscreen display allows oscilloscope operation without an external pointing device
- Waveforms displayed in color, making correlation easy
- Current configuration parameters displayed near the waveform display and are color-coded to make identification easy
- Graphical interface menus and toolbars simplify complex measurement setups

### Horizontal controls set sweep speed and position

- Main sweep speeds from 200 ps/div to 20 s/div
- Delayed sweep speeds from 1 ps/div to main time base setting
- Intensified waveforms on main sweep window make it easy to see what will appear in delayed sweep window

### Acquisition and general controls start and stop the oscilloscope and do basic setup

- Run and stop controls for continuous or single-shot acquisitions
- Clear display before one or more acquisitions
- Default setup and Autoscale set initial configuration

### Hard disk drive and USB port for saving and restoring setups and measurement results

- Store measurement displays for inclusion in reports and test setup guides
- Store oscilloscope setups to repeat tests another time
- Hard disk stores oscilloscope operating system

### Trigger setup controls set mode and basic parameters

- Select Edge, Glitch, or Advanced Modes
- Choose input source and slope
- Set coupling for trigger
- Use graphical user interface to simplify configuration of pattern, state, delay, violation, and video triggers
- Use auxiliary trigger to increase triggering flexibility

### Vertical controls set input coupling, impedance, attenuation, and position

- AC or DC input coupling
- 1 M $\Omega$  or 50  $\Omega$  input impedance
- Input attenuation adjustable from 2 mV/div to 1 V/div (plus 2 V/div in 1 M $\Omega$ )
- Color-coded knobs make it easy to find the controls that affect each waveform

### Marker and quick measurements help measure waveform parameters

- Waveform markers A and B to check voltage and  $\Delta$ -time at any point on the displayed waveform
- Quick Meas executes up to four predefined measurements instantly

### Service Policy

The service policy of this oscilloscope requires replacing defective assemblies. Some assemblies can be replaced on an exchange basis. Items such as the vertical attenuators, which are subject to wear and tear based on frequency of use, are a maintenance item that may need occasional replacement.

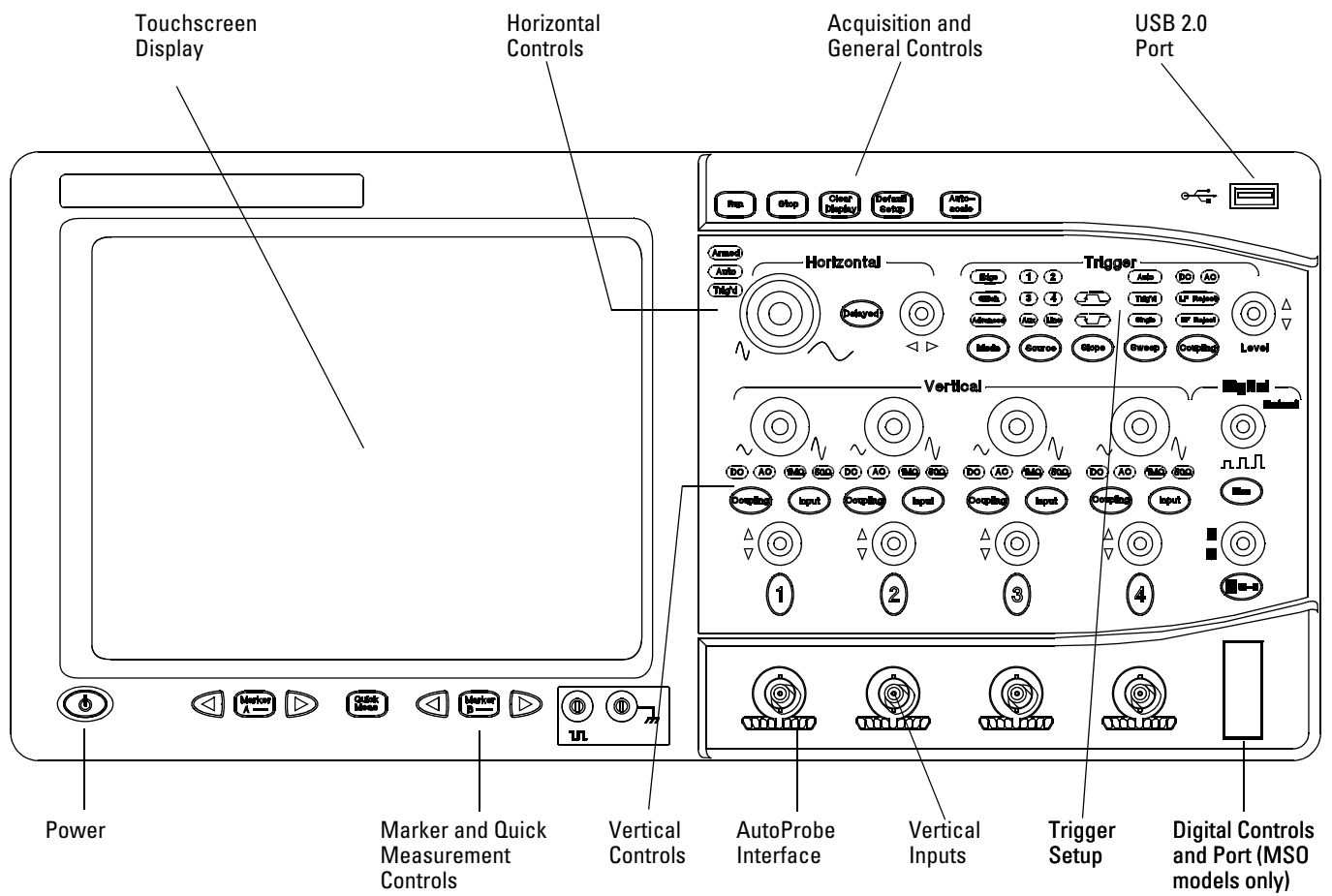

**8000 Series Oscilloscope Front Panel**

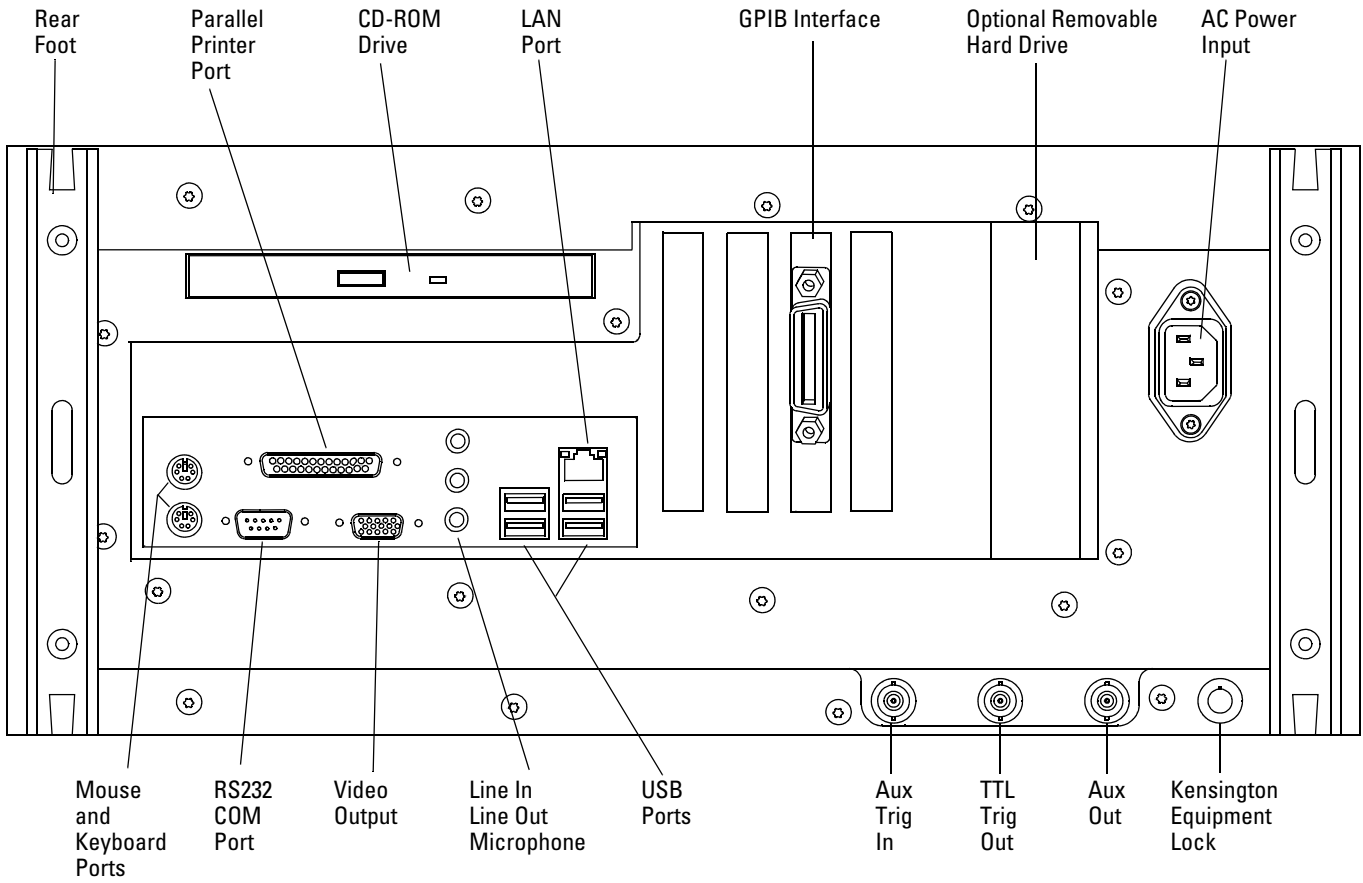

**8000 Series Oscilloscope Back Panel**

Note: Your instrument's back panel configuration may differ from this diagram.

---

## In This Book

This book provides the service documentation for the Agilent Technologies 8000-Series oscilloscopes. It is divided into eight chapters.

Chapter 1, “General Information,” provides general information and specifications.

Chapter 2, “Preparing for Use,” shows you how to prepare the oscilloscope for use.

Chapter 3, “Testing Performance,” gives performance tests.

Chapter 4, “Calibrating and Adjusting,” covers calibration and adjustment procedures, how to do them, and how often they need to be done.

Chapter 5, “Troubleshooting,” provides troubleshooting information.

Chapter 6, “Replacing Assemblies,” gives the procedures and techniques for replacing assemblies and other parts.

Chapter 7, “Replaceable Parts,” includes a list of exchange assemblies and other replaceable parts, part ordering information, and shipping information.

Chapter 8, “Theory of Operation,” briefly covers the internal operation of the oscilloscope.

At the back of the book you will find safety notices.



---

# Contents

## 1 General Information

- Instruments covered by this service guide 11
- To determine whether the oscilloscope is under warranty 12
- Accessories supplied 13
- Accessories available 14
- Options available 15
- Specifications & characteristics 16
- Environmental Conditions 17
-  Measurement Category 17
- Oscilloscope Dimensions 18

## 2 Preparing for Use

- To inspect package contents 20
- To connect power 22
- To connect the mouse, keyboard, LAN, printer, and GPIB cable 24
- To connect the standard 10073C probes 25
- To connect optional InfiniiMax oscilloscope probes 26
- To connect the digital probe 28
- Digital probe lead set 29
- To tilt the oscilloscope upward for easier viewing 31
- To turn on the oscilloscope 32
- To turn off the oscilloscope 32
- To verify basic oscilloscope operation 33
- Installing application programs on Infiniium 34
- Changing Windows System Settings 34
- To clean the oscilloscope 35

## 3 Testing Performance

- To test the DC calibrator 40
- To test input resistance 42
- To test single cursor voltage measurement accuracy with offset 43
- To test bandwidth 47
- To verify threshold accuracy 49
- To test time scale accuracy 59
- To test delta time measurement accuracy 61
- Performance Test Record 64

## 4 Calibrating and Adjusting

- To run the self calibration 69

## 5 Troubleshooting

- To install the fan safety shield 73
- To troubleshoot the oscilloscope 74
- Primary Trouble Isolation 76

## Contents

No Display Trouble Isolation	79
To check the backlight inverter voltages	81
To check the display board video signals	82
Power Supply Trouble Isolation	83
To check probe power outputs	85
To Check the keyboard	86
To check the LEDs	87
To check the motherboard, CPU, and RAM	88
To setup the BIOS	91
To troubleshoot the acquisition system	92
Software Revisions	94

## 6 Replacing Assemblies

To return the oscilloscope to Agilent Technologies for service	97
To remove and replace the top cover	98
To remove and replace the bottom sleeve	99
To disconnect and connect Mylar flex cables	101
To remove and replace the CD-ROM drive	102
To remove and replace the AutoProbe assembly	104
To remove and replace the internal digital input cable (MSO models only)	106
To remove and replace the backlight inverter board	107
To remove and replace the front panel assembly	108
To remove and replace the keyboard, touch screen, and flat-panel display assemblies	113
To remove and replace the acquisition board assembly	116
To remove and replace the PCI bridge board	117
To remove and replace the display board	119
To remove and replace the hard disk drive	120
To remove and replace the motherboard	122
To replace the Intel motherboard with the ADLINK motherboard	124
To remove and replace the power supply	131
To remove and replace the fan controller board	134
To remove and replace a fan	135
To remove and replace the probe power and control assembly	136

## 7 Replaceable Parts

Ordering Replaceable Parts	138
Power Cords	139
Exploded Views	140
Replaceable Parts List	145

## 8 Theory of Operation

Block-Level Theory	151
Attenuator Theory	155
Acquisition Theory	155

## Index

Instruments covered by this service guide 11  
Accessories supplied 13  
Options available 15  
Accessories available 14  
Specifications & characteristics 16

---

# General Information

This chapter of the *Agilent Technologies Infiniium Oscilloscope Service Guide* gives you general information about the oscilloscope. The following topics are covered in this chapter.

- Instruments covered by this guide
- Accessories
- Options
- Environmental category definitions
- Oscilloscope dimensions

---

## Instruments covered by this service guide

Oscilloscopes manufactured after the date this manual was released may be different from those described in this manual. The release date of this manual is shown on the title page. This manual will be revised as needed (when significant changes occur).

If you have an oscilloscope that was manufactured after the release of this manual, please check the Agilent Technologies website at [www.agilent.com](http://www.agilent.com) to see whether a newer version of this manual is available. You can perform a search for your oscilloscope's model number, go to its product page, and select Library.

### Year of Manufacture

You can determine the year the oscilloscope was manufactured by examining the serial number label that is affixed to the rear panel of the oscilloscope. The serial number is composed of two parts. The first part contains two letters and two numbers that signify the oscilloscope's county of origin and year date code. A year date code of "05" indicates that the oscilloscope was manufactured in 2005. The second part of the serial number contains a rolling number that is different for each oscilloscope.

**Table 1 -1**

---

**Oscilloscopes Covered by this Service Guide**

---

<b>Model</b>	<b>Description</b>
DSO8064A	Four-channel digitizing oscilloscope with 4 GSa/s sample rate in 2-channel mode, 2 GSa/s sample rate in 4-channel mode, 600 MHz bandwidth
MSO8064A	Four-channel digitizing oscilloscope with 4 GSa/s sample rate in 2-channel mode, 2 GSa/s sample rate in 4-channel mode, 600 MHz bandwidth, 16 digital channels.
DSO8104A	Four-channel digitizing oscilloscope with 4 GSa/s sample rate in 2-channel mode, 2 GSa/s sample rate in 4-channel mode, 1 GHz bandwidth.
MSO8104A	Four-channel digitizing oscilloscope with 4 GSa/s sample rate in 2-channel mode, 2 GSa/s sample rate in 4-channel mode, 1 GHz bandwidth, 16 digital channels.

The oscilloscope can be identified by the product number on the front or back panel.

## To determine whether the oscilloscope is under warranty

You can check your instrument's warranty status at [www.agilent.com](http://www.agilent.com). All you need is access to the world wide web and the instrument's model and serial numbers.

At the time this manual was published, the following step brought you to the “Infoline” web page on [www.agilent.com](http://www.agilent.com) where you can check instrument warranty status.

- 1 Direct your web browser to [www.agilent.com/find/warrantystatus](http://www.agilent.com/find/warrantystatus).**

If this URL no longer works because of changes to the [www.agilent.com](http://www.agilent.com) website, then search for “warranty status” at [www.agilent.com](http://www.agilent.com) to find the appropriate web page.

## Accessories supplied

### **Standard accessories supplied**

- Mouse, P/N 1150-7913
- Stylus, P/N 1150-7997
- Keyboard, P/N 1150-7809
- *User's Quick Start Guide*
- Accessory Pouch, P/N 54810-68701
- Front Panel Cover, P/N 54810-42201
- Power cord (see chapter 7, “Replaceable Parts,” for available power cords)
- (4) Agilent 10073C 10:1 passive probes

### **MSO standard accessories supplied**

- Probe Kit, P/N 54826-68701

---

## Accessories available

The following accessories are available for use with the Agilent Technologies Infiniium oscilloscope. Other accessories may be available. See your Agilent Technologies Sales Representative or visit [www.agilent.com](http://www.agilent.com).

**Table 1-1**

---

### 8000 Series Oscilloscope Accessories

---

1130A	1.5 GHz InfiniiumMax Differential and Single-Ended Probe Amplifier
E2669A	InfiniiumMax Connectivity Kit for Differential and Single-Ended Measurements
E2668A	InfiniiumMax Connectivity Kit for Single-Ended Measurements
E2675A	InfiniiumMax Differential Browser Probe Head
E2676A	InfiniiumMax Single-Ended Browser Probe Head
E2677A	InfiniiumMax Differential Solder-in Probe Head
E2678A	InfiniiumMax Differential and Single-Ended Socketed Probe Head
E2679A	InfiniiumMax Single-Ended Solder-in Probe Head
E2695A	InfiniiumMax Differential SMA Probe Head
1144A	800 MHz Active Probe Requires 1142A power supply
1145A	750 MHz 2-Channel, Low-Mass Active Probe Requires 1142A power supply
01144-61604	1:2 Probe Power Fan-Out To provide power for two 1144A or 1145A probes
1146A	10 kHz, 100 A AC/DC Current Probe
1147A	50 MHz, 50 A AC/DC Current Probe
1153A	200 MHz Differential Probe
1155A	750 MHz 2-Channel, Low-Mass Active Probe
1156A	1.5 GHz Active Probe
10070C	1:1 1 M $\Omega$ Passive Probe
10073C	10:1 2.2 M $\Omega$ Passive Probe
1162A	1:1 1 M $\Omega$ Passive Probe
1163A	10:1 500 $\Omega$ , Low-C Resistive Divider Passive Probe
1165A	10:1 10 M $\Omega$ Passive Probe
1171A	Low-Mass, Miniature 10:1 10 M $\Omega$ Passive Probe
10833A	GPIB cable, 1 m
10833B	GPIB cable, 2 m
10833C	GPIB cable, 4 m
10833D	GPIB cable, 0.5 m
54006A	6 GHz, 10:1 500 $\Omega$ or 20:1 1 k $\Omega$ Resistor Divider Probe
E2609B	Rackmount Kit
1184A	Testmobile with accessory drawer and tray for mouse/keyboard

---

## Options available

The following options are available for the Infiniium oscilloscope. Other options may be available. See your Agilent Technologies Sales Representative or visit [www.agilent.com](http://www.agilent.com) and perform a search for your oscilloscope's model number.

Table 1-2

---

### 8000 Series Oscilloscope Options

---

**Calibration Option**

A6J	ANSI Z540-Compliant Calibration
-----	---------------------------------

**Factory-Installed Instrument Options**

040	Increase acquisition memory to 8 M on half channel and 4 M on all channels
080	Increase acquisition memory to 16 M on half channel and 8 M on all channels.
160	Increase acquisition memory to 32 M on half channel and 16 M on all channels.
320	Increase acquisition memory to 64 M on half channel and 32 M on all channels.
640	Increase acquisition memory to 128 M on half channel and 64 M on all channels.

Note: Memory options are also available after oscilloscope purchase. See the "Customer-Installed Instrument Options" heading in this table.

002	EZJIT Jitter Analysis Software
003	High-Speed Serial Data Analysis Software with Clock Recovery
006	My Infiniium Integration Package
007	Low-Speed Serial Data Analysis Software for I2C and SPI
008	CAN Serial Data Analysis Software
009	InfiniiScan Event Identification Software
017	≥40 GB Removable Hard Disk Drive. Available on new oscilloscope purchase only. Replaces ≥40 GB internal hard disk drive with a ≥40 GB removable hard disk drive. Order the N5422A for additional hard disk drive cartridges that contain the full Windows operating system and oscilloscope application.

**Customer-Installed Instrument Options**

N5407A-040	Increase acquisition memory to 8 M on half channel and 4 M on all channels
N5407A-080	Increase acquisition memory to 16 M on half channel and 8 M on all channels.
N5407A-160	Increase acquisition memory to 32 M on half channel and 16 M on all channels.
N5407A-320	Increase acquisition memory to 64 M on half channel and 32 M on all channels.
N5407A-640	Increase acquisition memory to 128 M on half channel and 64 M on all channels.

Note: Memory options installed after oscilloscope purchase do not require opening the oscilloscope case.

E2681A	EZJIT Jitter Analysis Software
N5384A	High-Speed Serial Data Analysis Software with Clock Recovery
E2699A	My Infiniium Integration Package
N5391A	Low-Speed Serial Data Analysis Software for I2C and SPI

---

Chapter 1: General Information  
**Specifications & characteristics**

N5402A	CAN Serial Data Analysis Software
N5415A	InfiniiScan Event Identification Software
E2690B	Oscilloscope Tools for Advanced Jitter Analysis
N5397A	FPGA Dynamic Probe for Infiniium Mixed-Signal Oscilloscopes
N5392A	Ethernet Electrical Performance Validation and Compliance Software
N5395B	Ethernet Electrical Compliance Test Fixture
N5396A	Gigabit Ethernet Jitter Test Cable
N5416A	USB 2.0 Electrical Performance Validation and Compliance Software
E2646A	USB 2.0 SQiDD Test Fixture
N2649A	USB 2.0 High-Speed Test Fixture Set
E2625A	Communication Mask Test Kit
E2682A	Voice Control for Hands-Free Operation

---

## Specifications & characteristics

For complete specifications and characteristics, direct your web browser to [www.agilent.com](http://www.agilent.com) and perform a search for the oscilloscope's model number. Then select "Data Sheets" from the Library.

Specifications that are pertinent to each test are given in the "Testing Performance" chapter.

Specifications are valid after a 30 minute warm-up period, and within  $\pm 5^{\circ}\text{C}$  from the temperature at which the last self-calibration was performed.

---

## Environmental Conditions

### Overvoltage Category

This product is intended to be powered by MAINS that comply to Overvoltage Category II, which is typical of cord-and-plug connected equipment.

### Pollution Degree

The 80000 Series Oscilloscope may be operated in environments of Pollution Degree 2 (or Pollution Degree 1).

### Pollution Degree Definitions

Pollution Degree 1: No pollution or only dry, non-conductive pollution occurs. The pollution has no influence. Example: A clean room or climate controlled office environment.

Pollution Degree 2: Normally only dry non-conductive pollution occurs. Occasionally a temporary conductivity caused by condensation may occur. Example: General indoor environment.

Pollution Degree 3: Conductive pollution occurs, or dry, non-conductive pollution occurs which becomes conductive due to condensation which is expected. Example: Sheltered outdoor environment.

---

## Measurement Category



### Measurement Category

The 80000 Series oscilloscope is intended to be used for measurements in Measurement Category I.

### Measurement Category Definitions

Measurement category I is for measurements performed on circuits not directly connected to MAINS. Examples are measurements on circuits not derived from MAINS, and specially protected (internal) MAINS derived circuits. In the latter case, transient stresses are variable; for that reason, the transient withstand capability of the equipment is made known to the user.

Measurement category II is for measurements performed on circuits directly connected to the low voltage installation. Examples are measurements on household appliances, portable tools and similar equipment.

Measurement category III is for measurements performed in the building installation. Examples are measurements on distribution boards, circuit-breakers, wiring, including cables, bus-bars, junction boxes, switches, socket-outlets in the fixed installation, and equipment for industrial use and some other equipment, for example, stationary motors with permanent connection to the fixed installation.

Measurement category IV is for measurements performed at the source of the low-voltage installation. Examples are electricity meters and measurements on primary overcurrent protection devices and ripple control units.

### Transient Withstand Capability

The maximum transient withstand capability of this instrument is not specified. Do not apply more than 5 volts rms at the oscilloscope's vertical input BNC connectors.

---

## Oscilloscope Dimensions

**Figure 1-1**

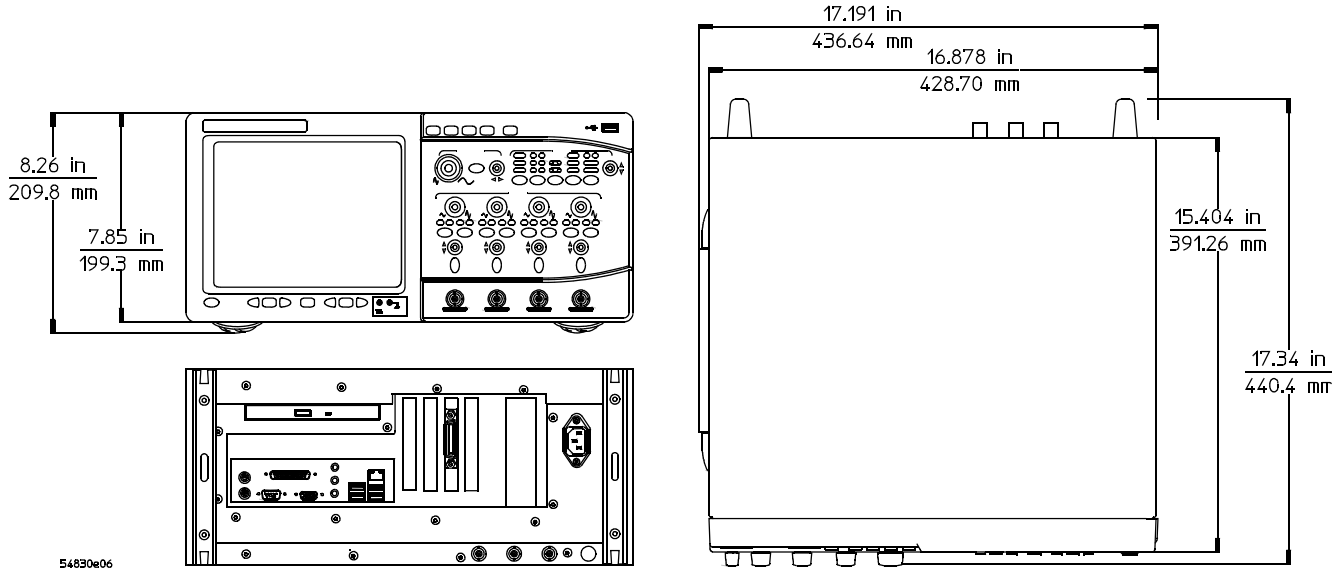

**8000 Series Oscilloscope Dimensions.**

---

To inspect package contents 20  
To connect power 22  
To connect the mouse, keyboard, LAN, printer, and GPIB cable 24  
To connect optional InfiniiMax oscilloscope probes 26  
To connect the digital probe 28  
Digital probe lead set 29  
To tilt the oscilloscope upward for easier viewing 31  
To turn on the oscilloscope 32  
To turn off the oscilloscope 32  
To verify basic oscilloscope operation 33  
Installing application programs on Infinium 34  
Changing Windows System Settings 34  
To clean the oscilloscope 35

---

# Setting Up the Oscilloscope

This chapter shows you how to set up your Infiniium oscilloscope, connect power and accessories, and verify general operation.

---

## To inspect package contents

- ❑ Inspect the shipping container for damage.

Keep a damaged shipping container or cushioning material until you have inspected the contents of the shipment for completeness and have checked the oscilloscope mechanically and electrically.
- ❑ Verify that you received the following items in the Infiniium Oscilloscope packaging.
  - Infiniium Oscilloscope
  - Mouse
  - Touchscreen Stylus
  - (4) 10073C 10:1 10 M $\Omega$  passive probes
  - Digital Probe Kit (MSO models only)
  - Accessory Pouch
  - Front Panel Cover
  - Keyboard
  - Power cord (See page 139)
  - *User's Quick Start Guide*

If anything is missing, contact your nearest Agilent Technologies Sales Office. If the shipment was damaged, contact the carrier, then contact the nearest Agilent Technologies Sales Office.
- ❑ Inspect the oscilloscope.
  - Contact your Agilent Technologies sales office if:
    - mechanical damage or a defect is apparent
    - the oscilloscope does not operate properly
  - If the shipping container is damaged, or the cushioning materials show signs of stress, notify the carrier and your Agilent Technologies Sales Office. Keep the shipping materials for the carrier's inspection. The Agilent Technologies Sales Office will arrange for repair or replacement at Agilent's option without waiting for claim settlement.

**Figure 2-1**  
**Package Contents for the 8000 Series Infiniium Oscilloscopes**

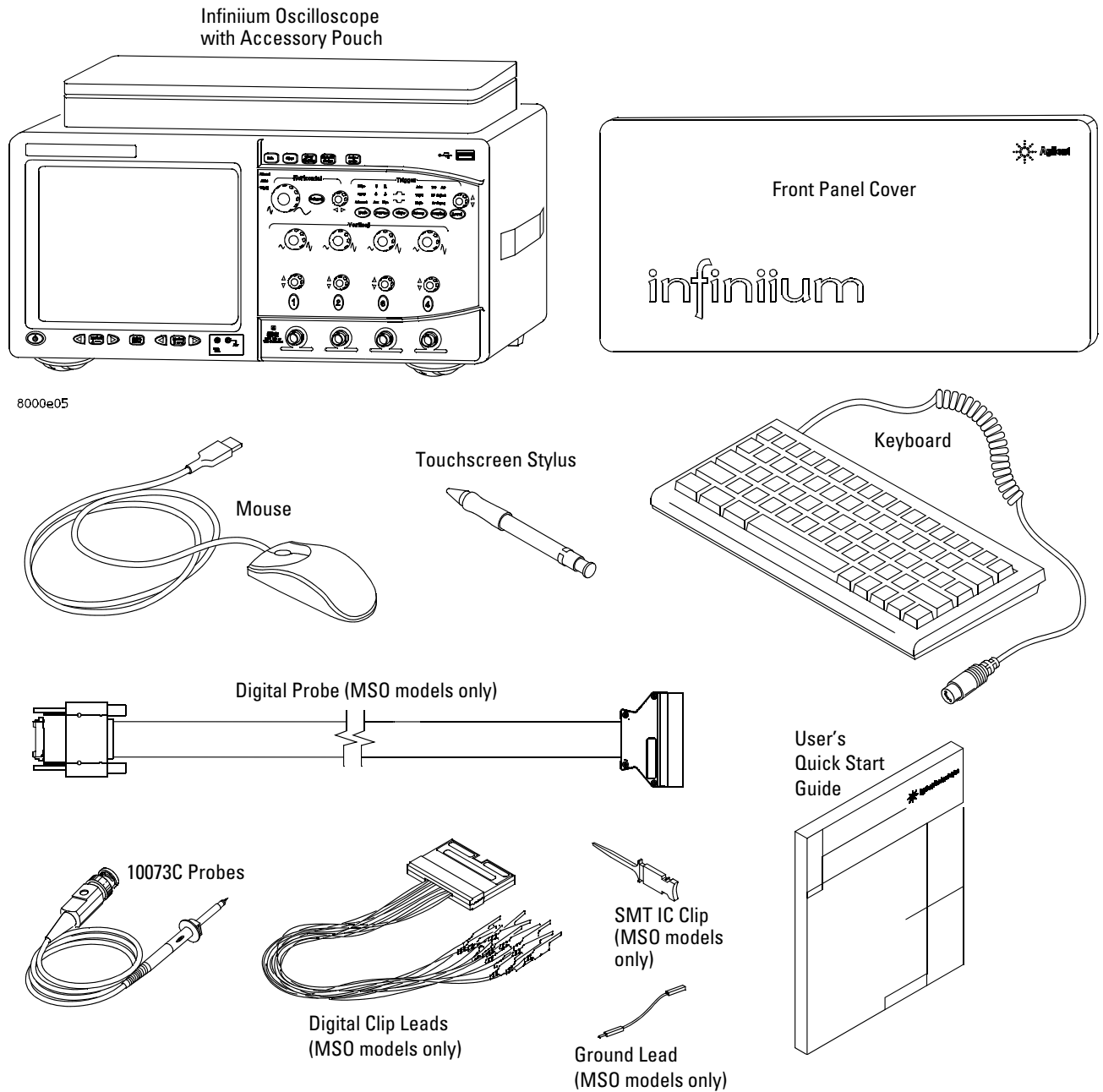

---

## To connect power

- 1 Position the oscilloscope where it will have sufficient clearance for airflow around the top, back, and sides.
- 2 Position the oscilloscope so that it is not difficult to unplug the power cord.

Figure 2-2

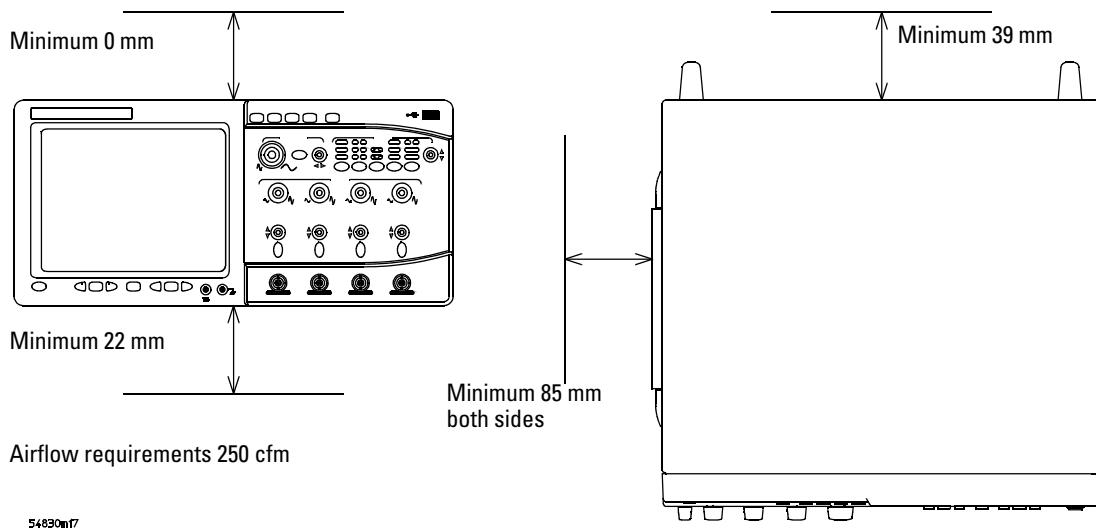

### Positioning the Infiniium Oscilloscope with Sufficient Clearance

- 3 Connect the power cord to the rear of the oscilloscope, then to a suitable AC voltage source (100 to 240 VAC  $\pm 10\%$ , 47 to 63 Hz, all models)  
8000 Series oscilloscope maximum power dissipation: 440 W.

**Figure 2-3**

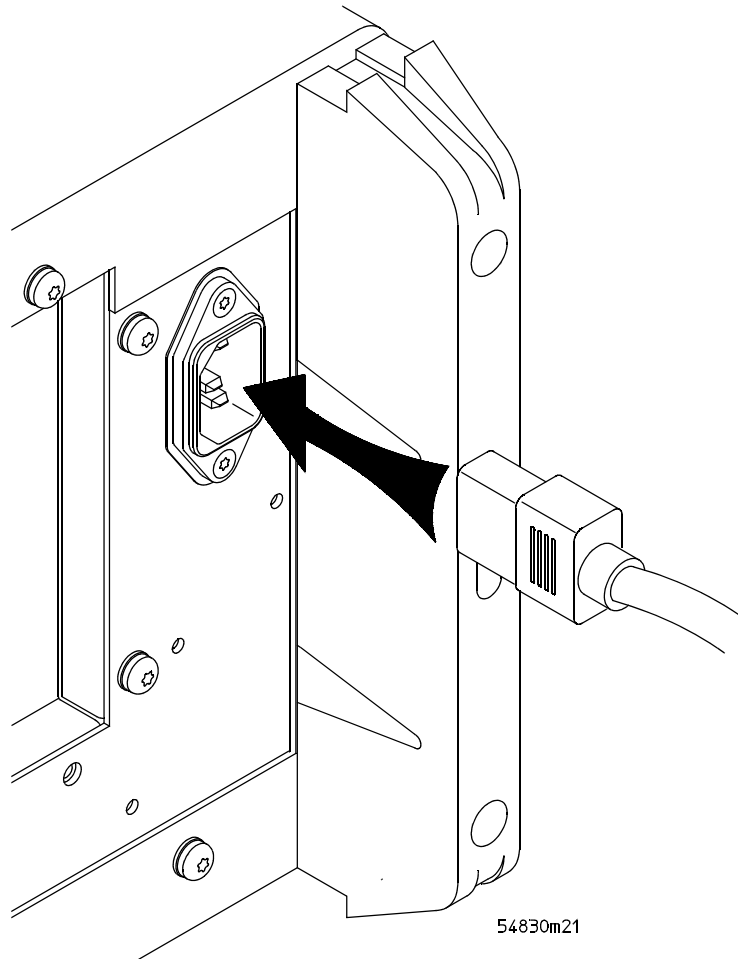

**Infiniium Oscilloscope Power Cord Connection**

The oscilloscope power supply automatically adjusts for line input voltages in the range 100 to 240 VAC. Therefore, you do not need to adjust an input line voltage setting. The power cord provided is matched by Agilent Technologies to the country of origin of the order.

- 4** Ensure that you have the correct line cord. See page 139.

---

## To connect the mouse, keyboard, LAN, printer, and GPIB cable

Mouse. Plug the mouse into the mouse connector on the back panel of the oscilloscope.

While you can operate many oscilloscope functions using only the front-panel keys and knobs, you will need the mouse to access advanced oscilloscope functions through the graphical interface, or to find out more about the oscilloscope through the built-in information system.

Keyboard. Plug the keyboard cable into the keyboard connector on the back panel of the oscilloscope.

A keyboard must be plugged into the oscilloscope before the Windows operating system has started booting.

LAN Cable. Connect your LAN cable to the RJ-45 connector on the back panel of the oscilloscope.

Depending on your building's LAN configuration, you may need to set up the oscilloscope's network configuration after connecting the LAN cable to the oscilloscope. If your building's network uses DHCP, many parameters will already be compatible. Before you set up the network configuration, you should exit the oscilloscope application. If you do not know how to setup the network, see your network administrator or use the Windows XP on-line help.

Printer Cable. If you have a USB printer, you will need to connect its cable to one of the four USB ports on the rear panel, or to the USB port on the front panel.

If you have a parallel printer, you will need to connect its parallel printer cable to the Parallel Printer connector on the oscilloscope.

GPIB Cable. If you will be controlling the oscilloscope through the GPIB, attach your GPIB cable to the GPIB connector on the rear of the oscilloscope.

Figure 2-4

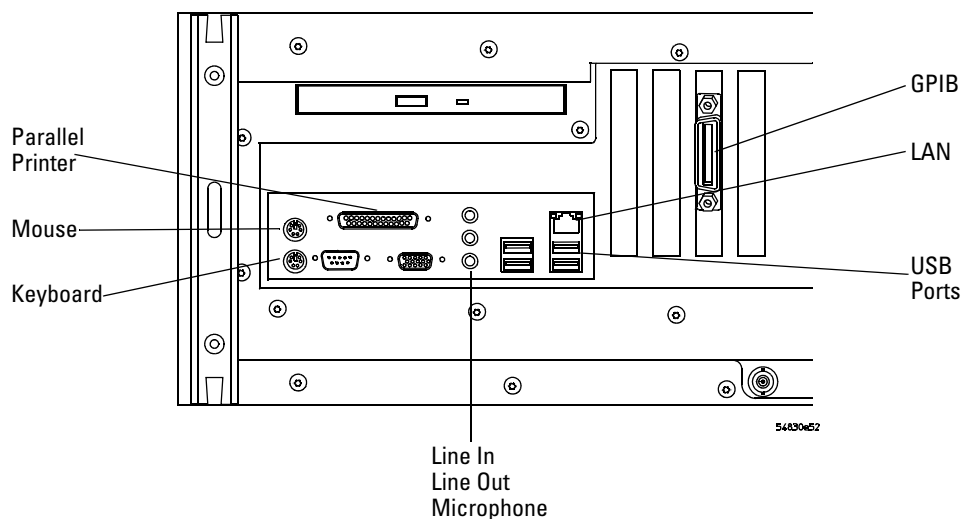

### Back Panel

Note: Your instrument's rear panel configuration may differ from this diagram. Connect the cables based on your instrument's configuration.

---

## To connect the standard 10073C probes

- 1 Attach the probe connector to the desired oscilloscope channel or trigger input. Rotate the BNC connector until it slides on easily and push it straight on. Rotate the locking ring until it latches into place.

Figure 2-5

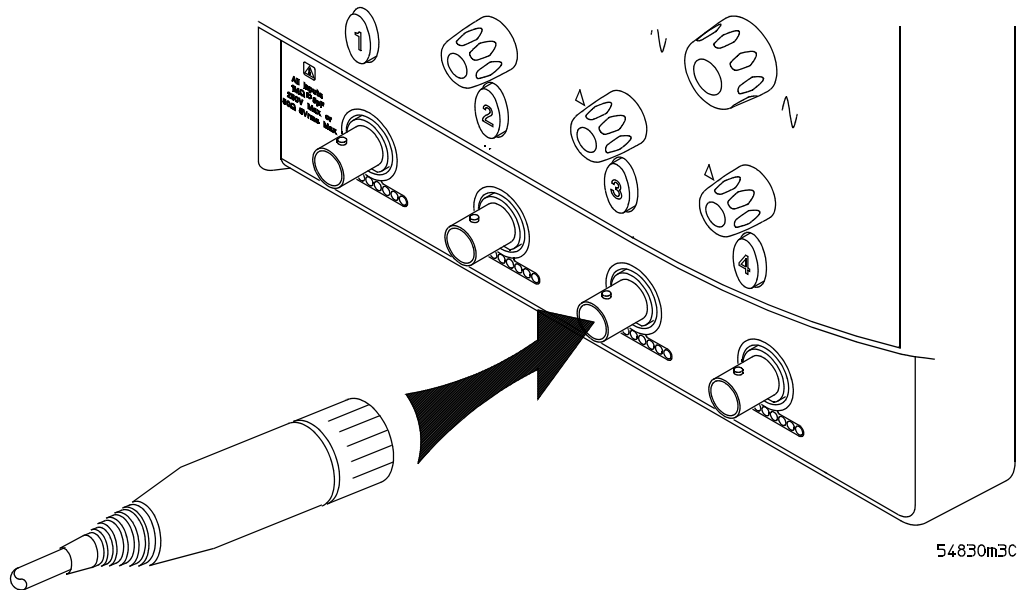

### Attaching the Probe Connector

- 2 Connect the probe to the circuit of interest using the browser or other probing accessories.
- 3 To disconnect the probe, rotate the locking ring counterclockwise so it unlocks, then pull the BNC connector body away from the front panel of the oscilloscope.

---

### CAUTION



Do not exceed the maximum input voltage rating. The maximum input voltage for 8000 Series oscilloscopes 50  $\Omega$  inputs is 5 Vrms, CAT I. Maximum voltage at 1 M $\Omega$  impedance is  $\pm 100$  V (DC + AC) [AC < 10 kHz], CAT I.

---

---

## To connect optional InfiniiMax oscilloscope probes

- 1 Attach the probe connector to the desired oscilloscope channel or trigger input. Push it straight on until it latches into place.

Figure 2-6

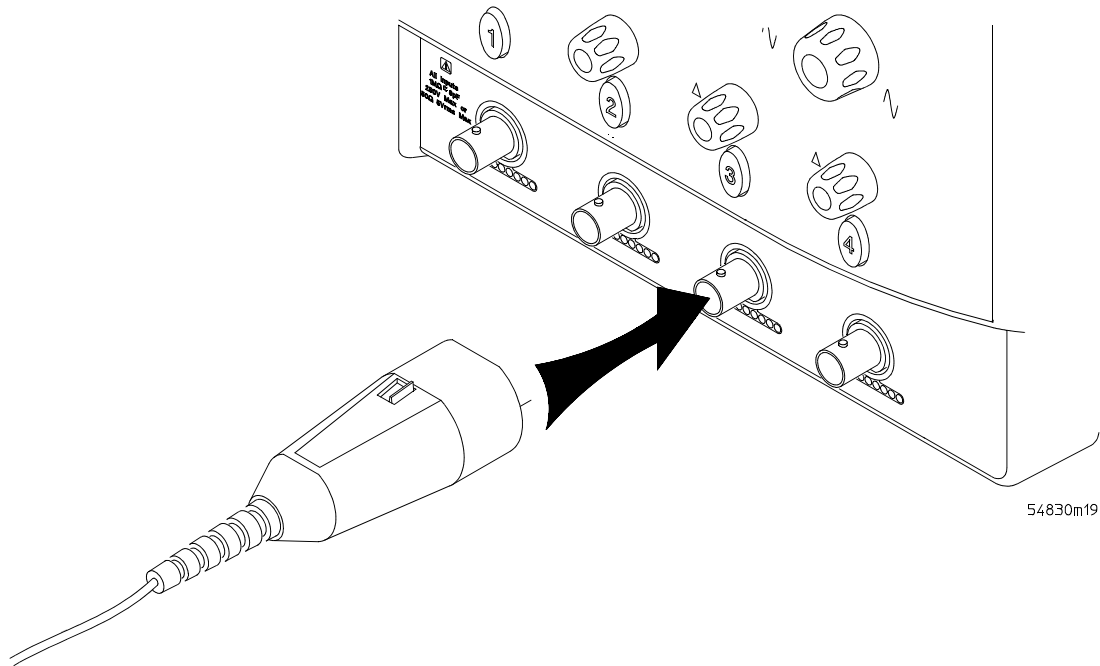

### Attaching the Probe Connector

- 2 Connect the probe to the circuit of interest using the browser or other probing accessories.

Figure 2-7

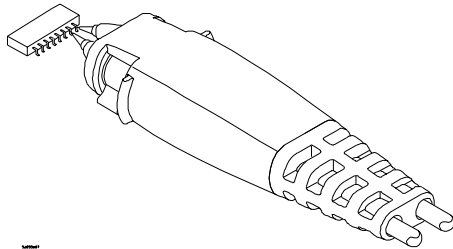

### Probing the Circuit

- 3 To disconnect the probe, push the small latch on top of the probe connector to the left, then pull the connector body away from the front panel of the oscilloscope without twisting it.

Figure 2-8

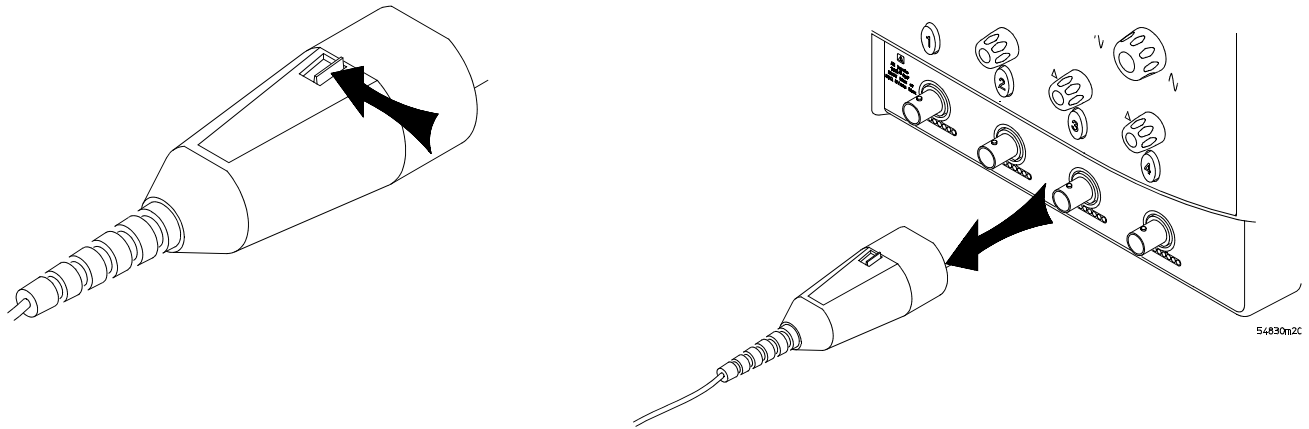

#### Disconnecting the Oscilloscope Probe

---

**CAUTION**

---

Do not attempt to twist the snap-on probes on or off the oscilloscope's BNC connector. Twisting the probe connector body will damage it.

---

**CAUTION**

For the 8000 series oscilloscopes do not exceed the maximum input voltage rating. The maximum input voltage for 50  $\Omega$  inputs is 5 Vrms, CAT I. Maximum voltage at 1 M $\Omega$  impedance is  $\pm 100$  V (DC + AC) [AC < 10 kHz], CAT I.

---

---

## To connect the digital probe

The Agilent Mixed-Signal Oscilloscopes (MSOs) are the only oscilloscopes to fully integrate 16 digital timing channels with the analog oscilloscope channels.

The digital clip lead marked clk (clock) is unused. All the other digital clip leads are used for the digital channels.

- 1 Push the small connector end of the digital cable with the tab key facing left into the digital connector.
- 2 Tighten both thumb screws.

Figure 2-9

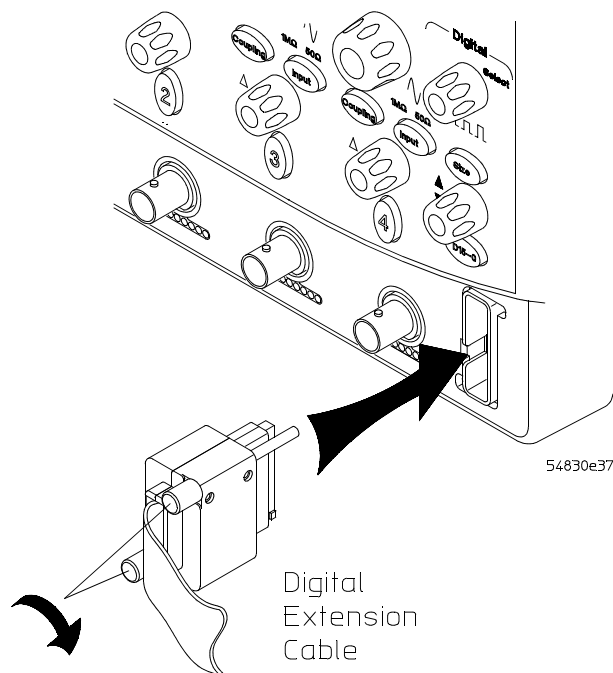

Connecting the Digital Cable to the Oscilloscope

## Digital probe lead set

The digital clip lead marked clk (clock) is unused. All the other digital clip leads are used for the digital channels.

The probe lead set has 16 digital channels with a ground lead for each channel.

**Figure 2-10**

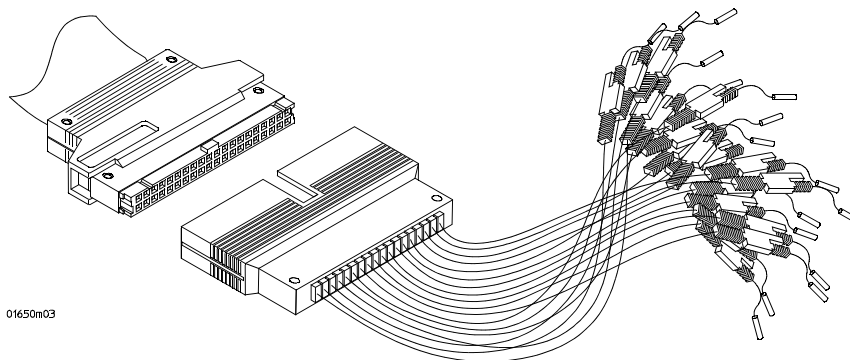

### Digital Probe Lead Set

If a 0.63 mm square pin or a 0.66 diameter round pin is installed on the circuit under test, the signal and ground leads can be directly connect to these pins. Otherwise, the IC clips can be used to connect to the circuit.

**CAUTION**



Do not exceed the maximum input voltage rating of  $\pm 40$  V peak, CAT I.

### Probe tip isolation network and equivalent load

The probe tips of the probe lead set contain an isolation network which serves to minimize the loading effect of the digital channels on the circuit under test. The isolation network schematic is shown in Figure 2-11.

**Figure 2-11**

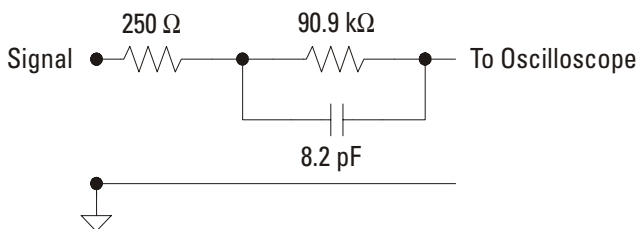

### Probe Tip Isolation Network

The loading effect of the probe tip on the circuit under test is represented by the circuit shown in the equivalent load schematic in Figure 2-12.

**Figure 2-12**

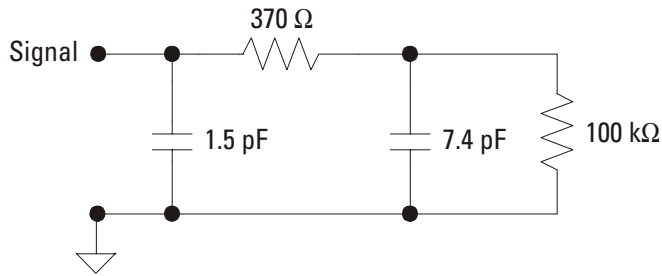

**Equivalent Load including oscilloscope**

**Direct connection through 40-pin connector**

The probe cable can also be directly plugged into various 40-pin connectors on the circuit board under test. This requires each signal pin of the 40-pin connector to have an isolation network (see Figure 2-11) on the circuit board. The pinout of the 40-pin connector is shown in Figure 2-13.

**Figure 2-13**

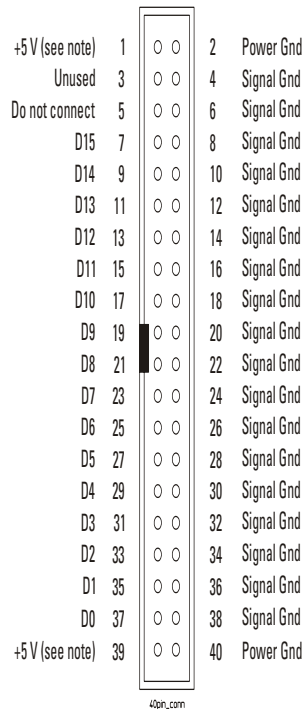

**40-pin Connector Pinout**

Note: +5 V is supplied by the oscilloscope to provide power for the demo board. DO NOT connect these pins to the circuit board under test.

**CAUTION**

Do not exceed the maximum input voltage rating of  $\pm 40$  V peak, CAT I. The isolation network (see Figure 2-11) must be used on all digital channels for this to be valid.

For more information on digital probing solutions, search for document number 5968-4632E on the Agilent Technologies web site at [www.agilent.com](http://www.agilent.com). This document is titled “Probing Solutions for Logic Analysis Systems.” It appears under the heading “Data Sheets, Demonstrations & Catalogs.”

---

## To tilt the oscilloscope upward for easier viewing

- 1 Lift up the front of the oscilloscope, grasp the wire bail near the center, and pull it down and forward until it latches into place.

**Figure 2-14**

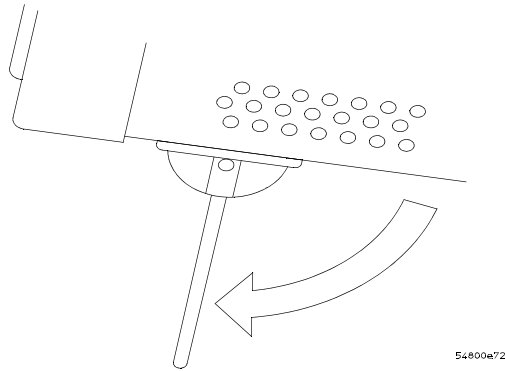

**Latching the Oscilloscope Front Feet**

---

## To turn on the oscilloscope

The first time that you turn on the oscilloscope, you will need to accept the Microsoft end user license agreement for Windows XP if prompted to do so.

- 1 Depress the power switch in the lower left corner of the oscilloscope front panel.

Figure 2-15

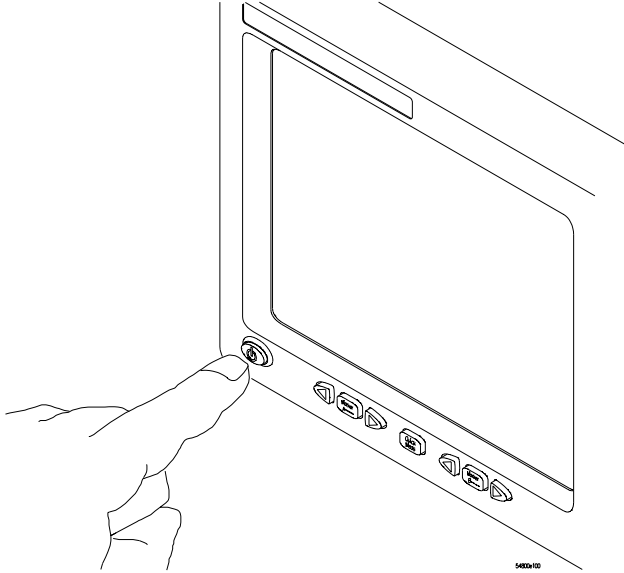

### Turning on the Oscilloscope

The oscilloscope boots-up and the oscilloscope display appears. Now the oscilloscope is ready to use.

- 2 Hook up all cables and accessories before applying power. You can connect and disconnect probes while the oscilloscope is turned on.

---

## To turn off the oscilloscope

- 1 Momentarily depress the power switch at the lower left corner of the oscilloscope front panel. The oscilloscope will go through a normal Windows shutdown process.

---

## To verify basic oscilloscope operation

- 1 Connect an oscilloscope probe to channel 1.
- 2 Attach the probe to the probe compensation output on the front panel of the oscilloscope.

Use a probe grabber tip so you do not need to hold the probe. The probe compensation output is marked with a square wave symbol.

Figure 2-16

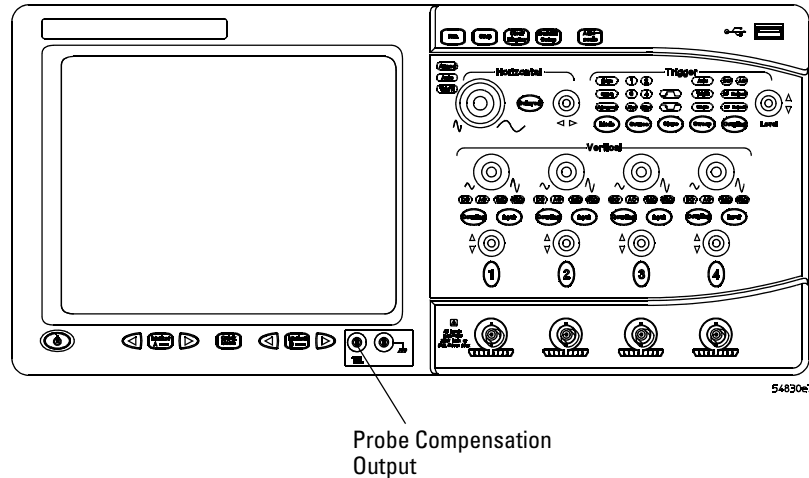

- 3 Press the Default Setup key on the front panel.  
The display will pause momentarily while the oscilloscope is configured to its default settings.
- 4 Press the Autoscale key on the front panel.  
The display will pause momentarily while the oscilloscope adjusts the sweep speed and vertical scale. You should then see a square wave with an amplitude of approximately 1.1 Vpp at about 700 to 800 Hz. If you do not see the waveform, ensure your power source is adequate, the oscilloscope is powered-on, and the probe is connected securely to the front-panel channel input BNC and to the probe calibration output.
- 5 Move the mouse around on the mouse surface and verify that the on-screen mouse pointer coincides with the mouse movement.

## Installing application programs on Infiniium

Infiniium is an open Windows system. This allows you to install your own application software. Agilent has verified that the following applications are compatible with the Infiniium oscilloscope application.

- Agilent Vector Signal Analysis
- Agilent VEE Pro
- Amherst Systems Oscilloscope Tools
- Microsoft Office 2000
- MathWorks MATLAB
- Mathsoft MathCad 2001i
- McAfee VirusScan
- Symantec Norton AntiVirus

Before installing any software, you should exit the oscilloscope application.

If you install an application other than those which Agilent has tested, it is possible that it could break the oscilloscope application. This would require you to reinstall the oscilloscope application. Refer to the *Infiniium Oscilloscope User's Quick Start Guide* for instructions on reinstalling the oscilloscope application.

---

## Changing Windows System Settings

Before changing any Windows System settings outside of the oscilloscope application you should **Exit** the oscilloscope application.

There are several Windows System settings that can be changed to suit your own personal preferences. However, there are some system settings that you should avoid changing because it will interfere with the proper operation of the oscilloscope.

- Do not change the Power Options.
- Do not change the System Properties Hardware Tab settings.
- Do not change the System Properties Advanced Tab settings.
- Do not change the Regional and Language Options Advanced Tab settings.
- Do not remove Fonts.
- Display Settings
  - Do not change or turn off the default screen saver. The screen saver turns off the display's backlights, extending their life.
  - Do not change the screen resolution or the color quality using the Control Panel Display Settings. You may modify display settings by double-clicking the Intel Graphics Media Accelerator Driver icon in the System tray.
  - Do not modify the Advanced settings.
- Do not use the Administrative Tools to enable or disable Internet Information Services (Web Server). Use the Infiniium Web Control dialog box to enable or disable the Web Server.

---

## To clean the oscilloscope

- Clean the oscilloscope with a soft cloth dampened with a mild soap and water solution.

---

### **CAUTION**

Do not use too much liquid in cleaning the oscilloscope. Water can enter the Infiniium front panel, damaging sensitive electronic components.



Testing Interval	38
Equipment Required	38
Self-Test Verification	38
Test Record	38
Operating Hints	38
Specifications	39
Performance Test Procedures	39
To test the DC calibrator	40
Procedure	40
To test input resistance	42
Procedure	42
To test time scale accuracy	59
Procedure	60
To test delta time measurement accuracy	61
Procedure	63
To test single cursor voltage measurement accuracy with offset	43
Procedure	43
To test bandwidth	47
Equivalent Time Test	47
Real Time Test	48
To verify threshold accuracy	49
Performance Test Record	64

---

# Testing Performance

The procedures in this section test measurement performance using performance specifications.

## Testing Interval

The performance test procedures may be performed for incoming inspection of the oscilloscope and should be performed periodically thereafter to ensure and maintain peak performance. The recommended test interval is yearly or every 2,000 hours of operation.

### Test Interval Dependencies

The test interval depends on frequency and severity of use and the environmental conditions under which the oscilloscope is used. In recording test results, you may find that the test interval could be shortened or lengthened; however, such a decision should be based on substantial quantitative data.

See Also

See Chapter 4, “Calibrating and Adjusting,” for information about the calibration cycle.

## Equipment Required

Equipment required for each test is listed in the test. Any equipment satisfying the critical specifications listed may be substituted for the recommended model. The procedures are based on the model or part number recommended.

## Self-Test Verification

To verify system operation with high confidence, without the test equipment and time required for performance tests, perform the self-tests. These internal tests verify many functions of the oscilloscope.

To run the self-tests, enable the graphical interface, then select Self Test from the Utilities menu. The Self Test drop down list box allows you to select oscilloscope Self Tests, Key and Knob Test, or LED Test. A message is displayed with the instruction to remove all inputs to the oscilloscope. During execution of the self-tests, the oscilloscope displays diagnostic messages indicating the status of each test.

If one of the self-tests fails, FAILED is displayed rather than PASSED, and a 16-bit diagnostic code is displayed. This code is used by factory service personnel when troubleshooting the main assembly. Failure of a self-test indicates an assembly failure. The assembly must be replaced before you attempt performance verification. For more troubleshooting information, refer to see “Troubleshooting” on page 71.

## Test Record

You can record the results of the performance tests in the Performance Test Record provided at the end of this chapter. The Performance Test Record lists the performance tests and provides an area to mark test results. You can use the results recorded at incoming inspection for later comparisons during periodic maintenance, troubleshooting, and after repairs or adjustments.

## Operating Hints

Some knowledge of operating the oscilloscope is helpful; however, these procedures are written so that little experience is necessary. The following two hints will speed progress

of the testing.

### Clear Display

When using many averages, it often takes awhile for a waveform display to stabilize after a change. When a control on the oscilloscope is changed, averaging automatically restarts. When just the input signal is changed, the oscilloscope must average new data with the old so it takes longer for the waveform to stabilize.

Press the Clear Display key while changing input signals. The oscilloscope will restart averaging and give a quick indication of the result of the signal change.

### Averaging

Averaging is used to assure a stable signal for measurements. It is not necessary to wait for complete stability of the signal (averaging complete), as long as the measurement is well within the limits of the test.

## Specifications

The specifications that apply to a particular test are given with the test procedure. For complete specifications and characteristics see the oscilloscope's datasheet. The datasheet can be viewed by directing your web browser to [www.agilent.com](http://www.agilent.com) and performing a search for the oscilloscope's model number. The datasheet will be in the "Library."

## Performance Test Procedures

Performance test procedures start with the next paragraph. Procedures may be done individually and in any order.

### **Let the oscilloscope Warm Up Before Testing**

Allow the oscilloscope to warm up for at least 30 minutes prior to beginning performance tests. Failure to allow warm-up may cause the oscilloscope to fail tests.

## Fluke MET/CAL Procedures

Fluke MET/CAL procedures are available for the 8000 Series oscilloscopes.

The MET/CAL badge with "PROCEDURES AVAILABLE" signifies that Fluke has created Warranted MET/CAL procedures to verify the performance of this instrument using MET/CAL metrology software. These procedures can be obtained from Fluke. Please see <http://www.fluke.com> and search for MET/CAL for more information.



## To test the DC calibrator

The Aux Out BNC on the back panel is used for self-calibration. Though calibrator accuracy is not specified in the performance specifications, it must be within limits in order to provide accurate self-calibration.

**Test Limits:** -2.4 v to +2.4 v, DC gain accuracy  $\pm 0.2\%$

### Equipment Required

Equipment	Critical Specifications	Recommended Model/Part
Digital Multimeter	0.1 mV resolution, better than 0.1% accuracy	Agilent 34401A
Cable	BNC	Agilent 10503A
Adapter	BNC (f) to banana (m)	Agilent 1251-2277

### Procedure

- 1 Connect the multimeter to the back panel Aux Out BNC.  
Use the BNC cable and the BNC to banana plug adapter.
- 2 Press Default Setup to set the oscilloscope to default conditions.
- 3 Select Calibration from the Utilities menu.
- 4 Select DC from the Aux Output drop-down list box.  
See Figure 3-1.

Figure 3-1

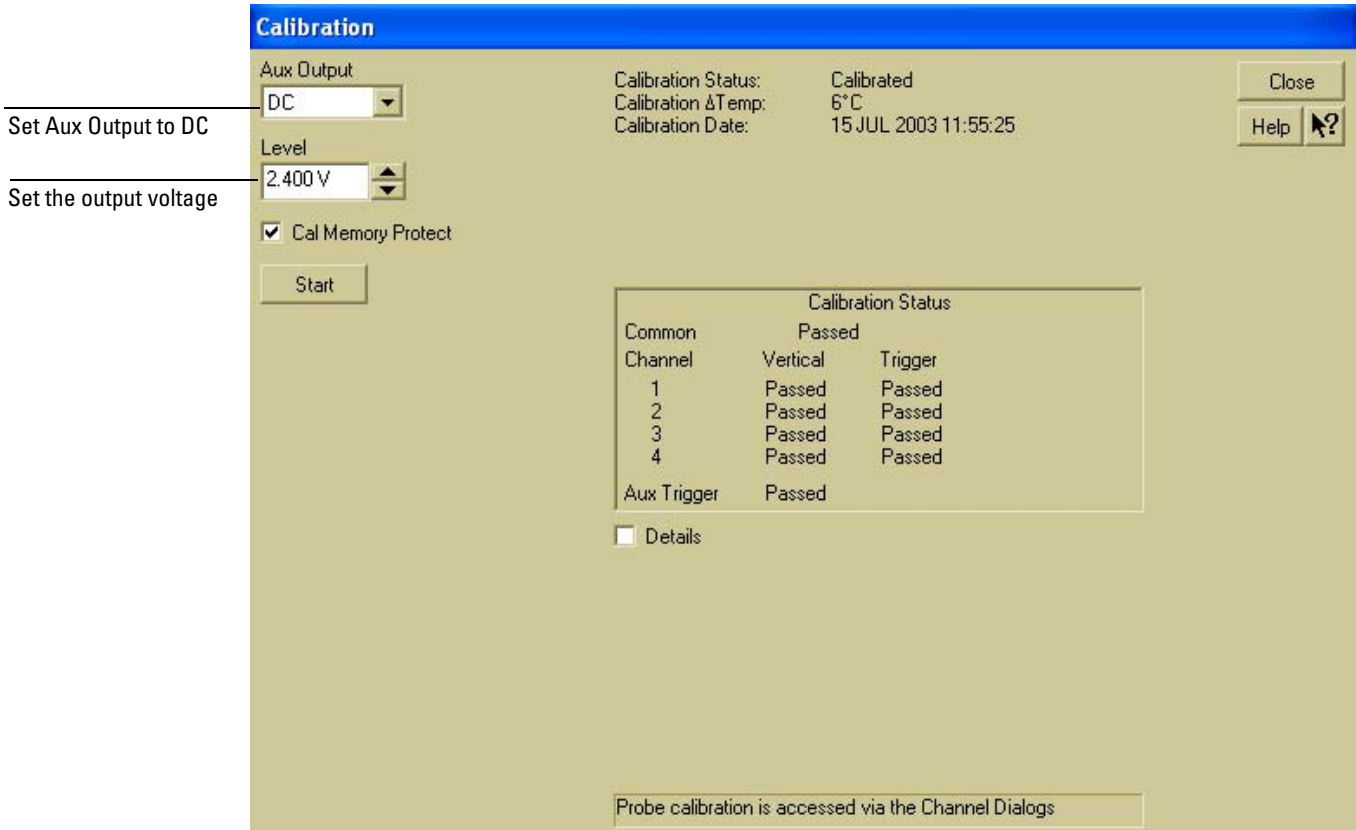

### Selecting DC in the Calibration Dialog

- 5 Set the DC output voltage to +2.400 V using the Level spin box or the numeric keypad dialog.

You can access the numeric keypad dialog by selecting (clicking on) the value in the Level box. Enter the values by selecting digits, signs, and exponents in the keypad. Select Close when finished.

- 6 The DVM should read near +2.400 V. Record the reading to four significant digits. V1 = \_\_\_\_\_.

- 7 Set the level to -2.400 V using the Level spin box or the numeric keypad dialog.

- 8 The DVM should read near -2.400 V. Record the reading. V2 = \_\_\_\_\_.

- 9 Subtract the second reading from the first reading, then divide the result by 4.8 V. For example, if V1 is +2.397 V and V2 is -2.395 V, then

$$\frac{V1-V2}{4.8 \text{ V}} = \frac{2.397 \text{ V}-(-2.395 \text{ V})}{4.8 \text{ V}} = 0.998$$

- 10 The final result should be between 0.998 and 1.002. Record the result in the "Performance Test Record" on page 64.

- 11 Select Close to exit the calibration menu.

**If the test fails**

Repair is necessary. See Chapter 5, "Troubleshooting."

---

## To test input resistance

This test checks the input resistance of the vertical inputs. A four-wire measurement is used to accurately measure the 50  $\Omega$  and 1 M $\Omega$  inputs.

**Specification:** 1 M $\Omega$   $\pm$ 1% and 50  $\Omega$   $\pm$ 1.5%

---

### Equipment Required

Equipment	Critical Specifications	Recommended Model/Part
Digital Multimeter	Measure resistance (4-wire) at better than $\pm$ 0.1% accuracy	Agilent 34401A
Cables (2)	BNC	Agilent 10503A
Adapter	BNC Tee (m)(f)(f)	Agilent 1250-0781
Adapters (2)	BNC (f) to dual banana (m)	Agilent 1251-2277

### Procedure

- 1 Set up the multimeter to make a four-wire resistance measurement.
- 2 Assemble the test cables.
  - a Use the two BNC-to-banana adapters to connect one end of each BNC cable to the four-wire resistance connections on the multimeter.
  - b Connect the free ends of the cables to the BNC tee.  
See Figure 3-2.

Figure 3-2

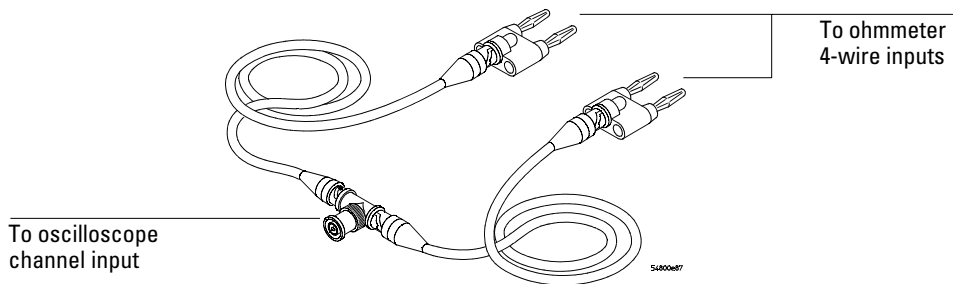

### Input Resistance Equipment Setup

- 3 Connect the male end of the BNC tee to the channel 1 input of the oscilloscope.
- 4 Press Default Setup to set the oscilloscope to default conditions.
- 5 Press the Input key for Channel 1 to select 1 M $\Omega$ , then 50  $\Omega$ , and verify resistance readings of 1 M $\Omega$   $\pm$ 10 k $\Omega$  and 50  $\Omega$   $\pm$ 0.75  $\Omega$  respectively.
- 6 Record the readings in the Performance Test Record.
- 7 Repeat steps 3 through 6 on the remaining channels, and on the external trigger of the oscilloscope.

## To test single cursor voltage measurement accuracy with offset

The single cursor accuracy specification is derived from the Dual Cursor and Offset accuracy specifications. By testing single cursor accuracy with offset, both Dual Cursor and Offset accuracies are tested at the same time. This eliminates the need to do separate tests for each specification.

This test verifies the voltage measurement accuracy of the oscilloscope. The measurement is made using dual-cursor automatic measurement so that offset errors are not a factor.

A power supply provides a reference voltage to check voltage measurement accuracy. The actual supply voltage is monitored for accuracy using a NIST-traceable voltmeter (especially at low voltages). A DC blocking capacitor and a BNC short are used to filter any noise generated by the power supply so it does not appear at the oscilloscope input.

### Specifications

- Gain Accuracy:  $\pm 1.25\%$  of full scale at full resolution channel scale
- Offset Accuracy:  $\pm(1.25\%$  of channel offset +  $2\%$  of full scale +  $1\text{ mV}$ ) at full-resolution scale
- Resolution: 8 bits, ( $0.4\%$  of full scale without averaging); or 12 bits, ( $0.024\%$  of full scale with 32 averages) at full resolution scale
- Dual Cursor Measurement:  $\pm(\text{gain accuracy} + \text{resolution})$
- Single Cursor Measurement:  $\pm(\text{gain accuracy} + \text{offset accuracy} + \text{resolution}/2)$

### Equipment Required

Equipment	Critical Specifications	Recommended Model/Part
Power Supply	7 mV to 30 VDC, 0.1 mV resolution	Agilent 6114A
Digital Multimeter (DMM)	Accuracy better than $\pm 0.1\%$ of reading	Agilent 34401A
Cables (2)	BNC	Agilent 10503A
Adapters (2)	BNC (f) to banana (m)	Pomona 1269
Adapters (2)	BNC tee (m)(f)(f)	Agilent 1250-0781
Blocking capacitor	0.18 $\mu\text{F}$	Agilent 10240B
Shorting cap	BNC	Agilent 1250-0929

### Procedure

- 1 Connect the equipment.  
 See Figure 3-3.
  - a Use a BNC-to-banana adapter to connect a BNC cable to the power supply.
  - b Connect a BNC tee to the other end of the cable and connect the tee to channel 1 of the oscilloscope.
  - c Connect another BNC cable to the tee at the oscilloscope and connect a BNC tee to the other end of the cable.
  - d Connect the blocking capacitor to the BNC tee and connect the BNC short to the blocking capacitor.
  - e Connect a BNC-to-banana adapter to the same BNC tee and connect the adapter to the DVM input.

**Figure 3-3**

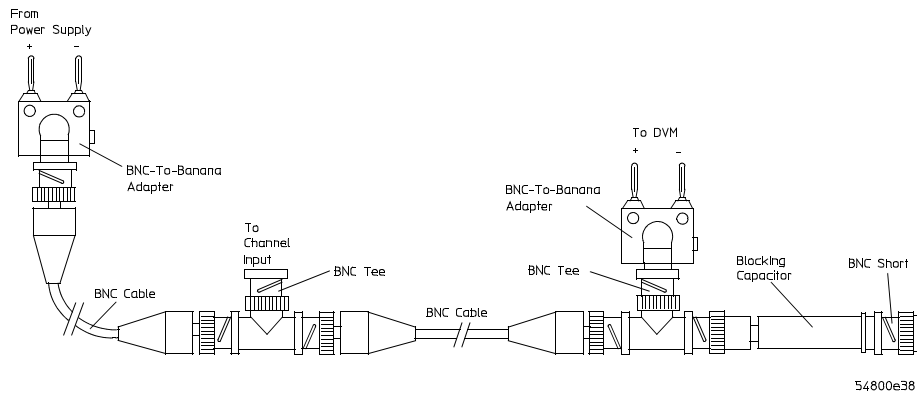

**Voltage Measurement Accuracy Equipment Setup**

- 2 Press Default Setup to set the oscilloscope to default conditions.
  - 3 Set all channels to DC using the Coupling key and to 1 M $\Omega$  input impedance using the Input key.
  - 4 Using the mouse, enable the graphical interface.
  - 5 Select Acquisition from the Setup menu.
  - 6 Select Equivalent Time sampling mode. Enable Averaging. Set the # of Averages to 32, using the numeric keypad dialog. Select Close.
- See Figure 3-4.

**Figure 3-4**

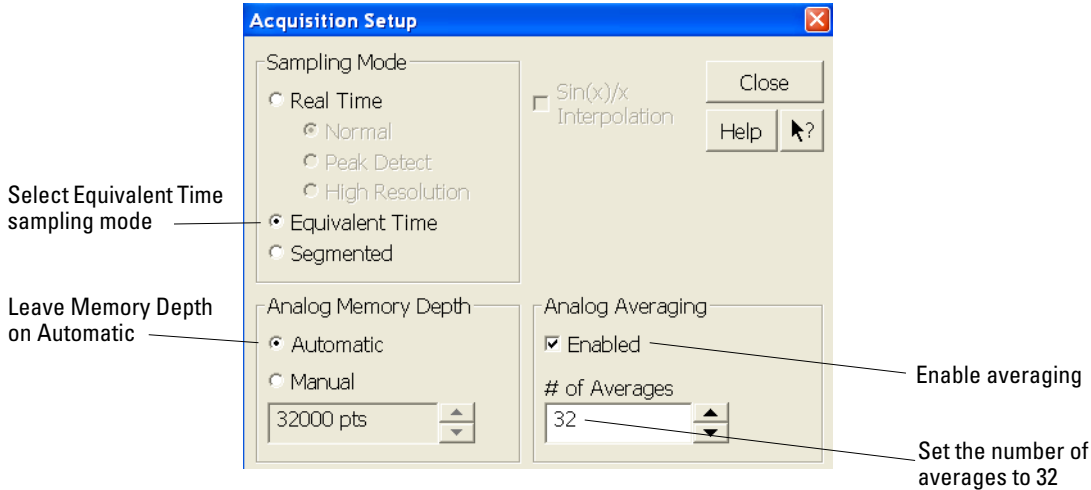

**Acquisition Setup for Voltage Accuracy Measurement**

- 7 Use the following table for steps 8 through 15.

Sensitivity (Volts/div)	Channel Offset	Vin (Supply)	Tolerance	Limits	
				Minimum	Maximum
5 V	17.5 V	35 V	+/- 1.52 V	33.48 V	36.52 V
2 V	7 V	14 V	+/- 609 mV	13.39 V	14.61 V
1.25 V	4.375 V	8.75 V	+/- 576 mV	8.17 V	9.33 V
500 mV	1.75 V	3.5 V	+/- 153 mV	3.35 V	3.65 V
250 mV	875 mV	1.75 V	+/- 142 mV	1.61 V	1.89 V
100 mV	350 mV	700 mV	+/- 31.4 mV	669 mV	731 mV
50 mV	175 mV	350 mV	+/- 16.2 mV	334 mV	366 mV
20 mV	70 mV	140 mV	+/- 7.08 mV	133 mV	147 mV
10 mV	35 mV	70 mV	+/- 4.04 mV	66 mV	74.0 mV
5 mV	17.5 mV	35 mV	+/- 2.52 mV	32.5 mV	37.5 mV

- 8 Select Vavg from the Voltage submenu of the Measure menu. Ensure that Channel 1 is selected in the "Enter Measurement Info" dialog and select OK.  
 See Figure 3-5.

**Figure 3-5**

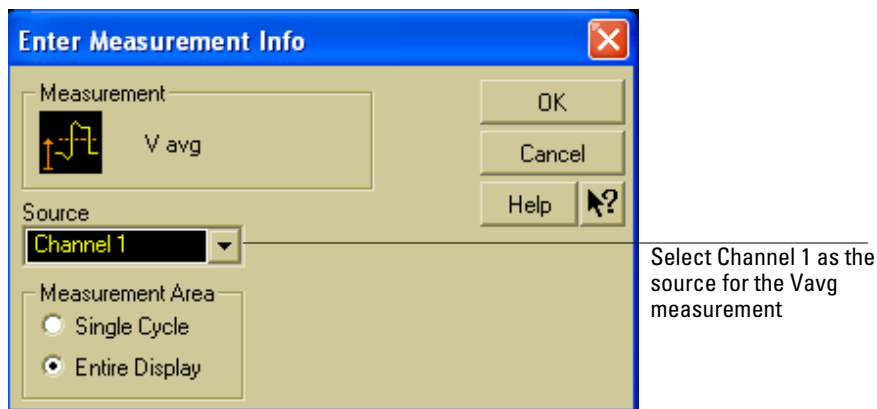

**Source Selection for Vavg Measurement**

- 9 Select Channel 1 from the Setup menu.
- 10 Set the sensitivity for Channel 1 to the volts/div value from the first row of the table in step 7. Set the Offset control to the offset value from the first row of the same table. Select Close.  
 See Figure 3-6.

Figure 3-6

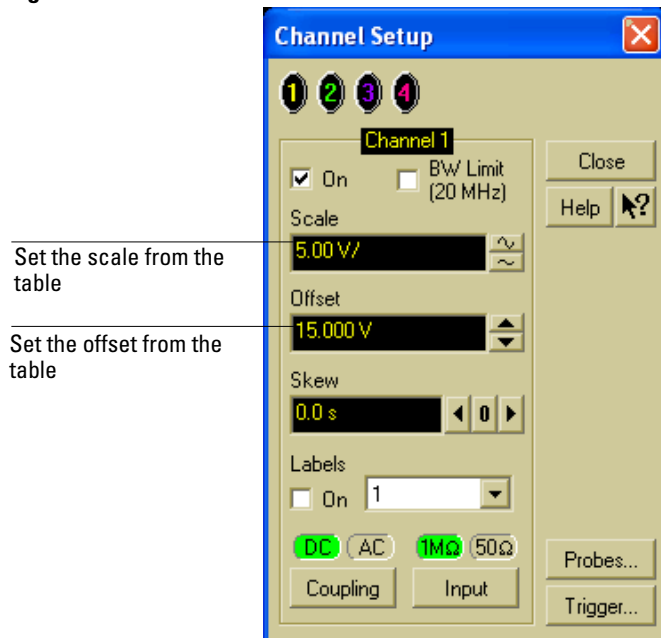

Vertical Scaling and Offset for Voltage Accuracy Measurement

**To Set Vertical Scale and Position**

You can also use the knobs to set the vertical scale and position, but it is usually easier to use the dialog box, particularly for the fine position setting.

- 11 With the supply disconnected from the channel input, note the  $V_{avg}$  mean reading. \_\_\_\_\_ V  
It may take a moment for this value to settle because of averaging.
- 12 Set the power supply voltage from the first line of the table. Use the voltmeter to adjust the power supply for the most accurate output.
- 13 Connect the power supply to the channel input and note the  $V_{avg}$  reading. \_\_\_\_\_ V  
Press Clear Display and wait a moment to read the value (so that averaging is complete).
- 14 Subtract the value in step 11 from the value in step 13. Record the difference in the Performance Test Record.
- 15 On the same channel, repeat steps 10 through 14 for the rest of the rows in the table.
- 16 With the channel keys, set the active channel OFF and the next ON.  
A channel is ON if its key is illuminated and OFF if it is not illuminated.
- 17 Move the BNC tee to the next channel and repeat steps 8 through 15 for that channel.
- 18 Repeat steps 8 through 17 for the rest of the channels.

**If the test fails**

Voltage measurement errors can be caused by the need for self-calibration. Before troubleshooting the oscilloscope, perform self-calibration. See "To run the self-calibration" in chapter 4, "Calibrating and Adjusting." If self-calibration fails to correct the problem, the cause may be the attenuator or main assembly.

---

## To test bandwidth

This test checks the bandwidth of the oscilloscope.

### Specification

Equivalent Time		Real Time	
MSO/DSO8064A	DC to $\geq 600$ MHz	MSO/DSO8064A	DC to $\geq 600$ MHz
MSO/DSO8104A	DC to $\geq 1$ GHz	MSO/DSO8104A	DC to $\geq 1$ GHz

---

### Equipment Required

Equipment	Critical Specifications	Recommended Model/Part
Signal Generator	1—1 GHz at $\approx 200$ mVrms	Agilent 8656B/8648A
Power Meter/Sensor	1—1 GHz $\pm 3\%$ accuracy	Agilent E4418B/8482A
Power Splitter	outputs differ by $< \pm 0.15$ dB	Agilent 11667A
Cable	Type N (m) 24 inch	Agilent 11500B
Adapter	Type N (m) to BNC (m)	Agilent 1250-0082

### Equivalent Time Test

- 1 Connect the equipment.
  - a With the N cable, connect the signal generator to the power splitter input. Connect the power sensor to one output of the power splitter.
  - b With an N-to-BNC adapter, connect the other splitter output to the channel 1 input.
- 2 Press Default Setup to set the oscilloscope to default conditions.
- 3 Select Acquisition from the Setup menu. Select Equivalent Time sampling mode. Enable averaging and set the # of Averages to 32. Select Close.
- 4 Set the vertical scale for Channel 1 to 100 mV/div using the knob. Select 50 $\Omega$  input impedance.
- 5 Set the sweep speed to 50 ns/div using the horizontal sweep speed knob.
- 6 Set the signal generator for 10 MHz at +5.0 dBm.

The signal on the oscilloscope screen should be about five cycles at six divisions amplitude.

#### Bandwidth Check Limits

Do not exceed 6 divisions when making the bandwidth check.

- 7 Select  $V_{\text{amptd}}$  from the Voltage submenu of the Measure menu.
- 8 After the measurement settles (when averaging is complete, about 10 seconds), note the  $V_{\text{amptd}}(1)$  reading at the bottom of the screen.  $V_{10\text{MHz}} = \underline{\hspace{2cm}}$  mV.
- 9 If using an 8482A Power Meter/Sensor, ensure that the power sensor calibration factors are loaded into the appropriate table of the E4418B Power Meter and that the table is turned on.

**To test bandwidth**

- 10** Change the signal generator output frequency to 600 MHz for the MSO/DSO8064A or 1 GHz for the MSO/DSO8104A and set the power meter Cal Factor % to the appropriate value from the calibration chart on the power sensor.

This step compensates the power meter reading for changes in the power sensor output at 500 MHz with respect to 10 MHz.

- 11** Adjust the signal generator output amplitude for a power reading as close as possible to 0.0 dB[REL]. Write down the actual reading. Reading = \_\_\_\_\_ dB [REL].

The reading on the power meter will be used to correct the final bandwidth value.

- 12** Set the sweep speed to 1 ns/div using the horizontal sweep speed knob.

- 13** After the measurement settles (averaging complete), note the  $V_{\text{amptd}(1)}$  reading.  
 $V_{600 \text{ MHz or } 1 \text{ GHz}} = \text{_____ mV}$

- 14** Calculate the response using the formula:

$$\text{response(dB)} = 20 \log_{10} \frac{V_{600 \text{ MHz or } 1 \text{ GHz}}}{V_{10 \text{ MHz}}} = 20 \log_{10} \text{_____} = \text{_____ dB}$$

For example:

$$20 \log_{10} \frac{487 \text{ mV}}{559 \text{ mV}} = 20 \log_{10} 0.871 = -1.19 \text{ dB}$$

- 15** Correct the result from step 14 with any difference in the power meter from step 11. Observe signs. For example:

Result from step 14 = -1.19 dB

Power meter reading = -0.5 dB(REL)

then true response = (-1.19) - (-0.5) = -0.69 dB

(\_\_\_\_\_) - (\_\_\_\_\_) = \_\_\_\_\_ dB

- 16** The result from step 15 should be between +3.0 dB and -3.0 dB. Record the result in the Performance Test Record.

- 17** Switch the power splitter from the channel 1 to the channel 2 input.

- 18** Turn off the current channel and turn on the next channel using the channel keys.

- 19** Repeat steps 4 through 18 for the remaining channels, setting the parameters of the channel being tested where appropriate.

**Real Time Test**

- 20** Select Acquisition from the Setup menu.

- 21** Select Real Time sampling mode, turn off Averaging, then select Close.

- 22** Repeat steps 4 through 19, testing all vertical channels with the upper frequency limit as follows:

Agilent MSO/DSO8064A; 600 MHz

Agilent MSO/DSO8104A; 1 GHz

**If the test fails**

Failure of the bandwidth test can be caused by a faulty attenuator or main assembly, or the need for high-frequency pulse response adjustment.

## To verify threshold accuracy

This test verifies the data channel threshold accuracy specifications of the Mixed Signal Oscilloscopes. The threshold voltage is the digital channel input voltage at which a bit transitions from logic 0 to logic 1 (low-to-high transition) or from logic 1 to logic 0 (high-to-low transition).

### Test Threshold Accuracy only on the Mixed-Signal Oscilloscopes (MSOs)

This test can only be performed on oscilloscope models that have digital channels.

#### Specification:

Threshold accuracy =  $\pm(100 \text{ mV} + 3\% \text{ of threshold setting})$ .

**When to Test** You should perform this test every 24 months or after 4000 hours of operation, whichever comes first.

**What to Test** Use these instructions to test the threshold accuracy of digital channels D15-D0.

**Verifying Test Results** After each threshold test, record the voltage reading in the Performance Test Record at the end of this chapter. If the voltage readings are within the limits in the Performance Test Record, the test passes.

**Let the Equipment Warm Up Before Testing** For accurate test results, let the test equipment and the oscilloscope warm up at least 30 minutes before testing.

#### Equipment Required

Equipment	Critical Specifications	Recommended Model/Part
Digital Multimeter	100 $\mu$ V resolution, DC voltage measurement accuracy better than $\pm 0.01\%$ of reading	Agilent 34401A
DC Signal Source	Voltage range $\pm 5.5 \text{ V}$ Voltage setting resolution $\pm 5 \text{ mV}$	Agilent 3631A or Fluke 5820A
Adapter	BNC Tee (m)(f)(f)	Agilent 1250-0781
Coaxial Cable (Qty. 2)	Length ~ 1 m BNC (m) connectors on both ends 50 $\Omega$ characteristic impedance	Agilent 8120-1840
Digital Cable Assembly	No substitute	Agilent 54826-61605 (Included in 54826-68701 logic probe kit)
Probe Tip Assembly	No substitute	Agilent 54838-61608
Probe Grounds (Qty. 5)	No substitute	Agilent 5959-9334
Adapter or BNC Breakout	BNC (f) to 20 AWG leads	Pomona 4969
Header Strip	$\geq 0.1 \text{ inch}$ (2.54 mm) spacing $\geq 32$ pins	Waldom Electronics 10-89-1161
Wire Strips (Qty. 2)	~1.5 inches (4 cm) in length 20 AWG	
Adapter	BNC (f) to dual banana	Agilent 1251-2277

## Connections

- 1 Construct a fixture using the BNC breakout and header strip as follows:
  - a Solder the pins of one side of the header strip together using one of the wire strips
  - b Solder the pins of the other side of the head strip together using the other wire strip.
  - c Solder the center (red) conductor of the BNC breakout to one side of the header strip.
  - d Solder the outer (black) conductor of the BNC breakout to the other side of the header strip.

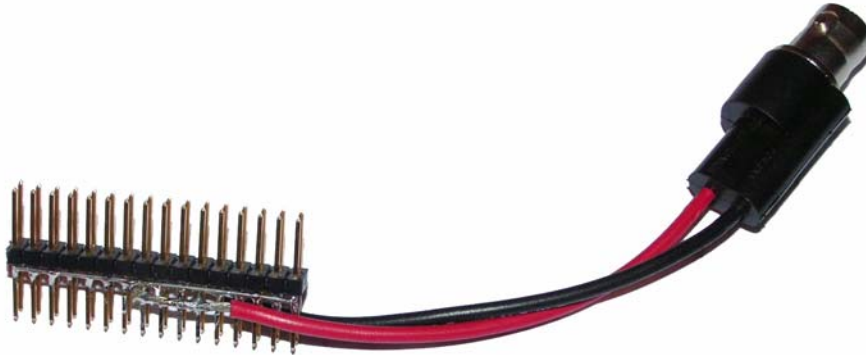

**Threshold Accuracy Test Fixture**

- 2 Connect the test system as shown below.
  - a Connect the signal leads of the probe tip assembly to the center (red) conductor side of the header strip.
  - b Connect the five ground leads of the probe tip assembly to the outer (black) conductor side of the header strip.

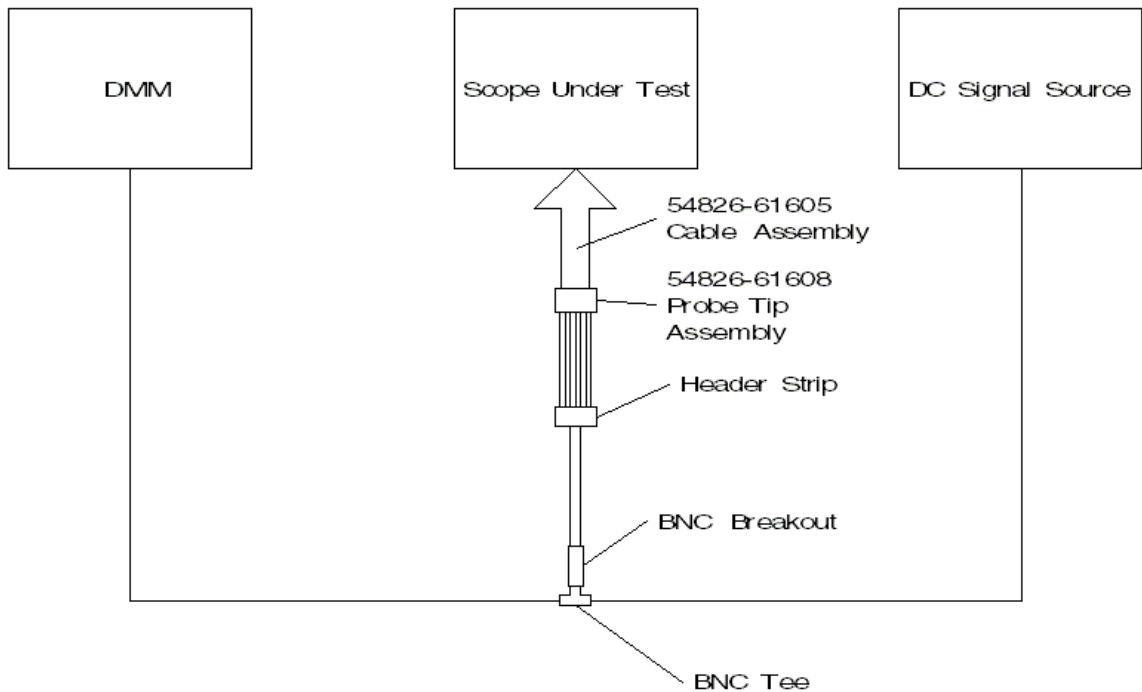

- 3 Power on the instruments and wait at least 30 minutes for the system to warm up before beginning this test.
- 4 Prepare the oscilloscope for test.
  - a Press the Default Setup button on the front panel.
  - b If the digital channels are not already displayed, press the D15-0 button on the lower right corner of the front panel.
  - c From the menu bar, select Setup and then select Digital...

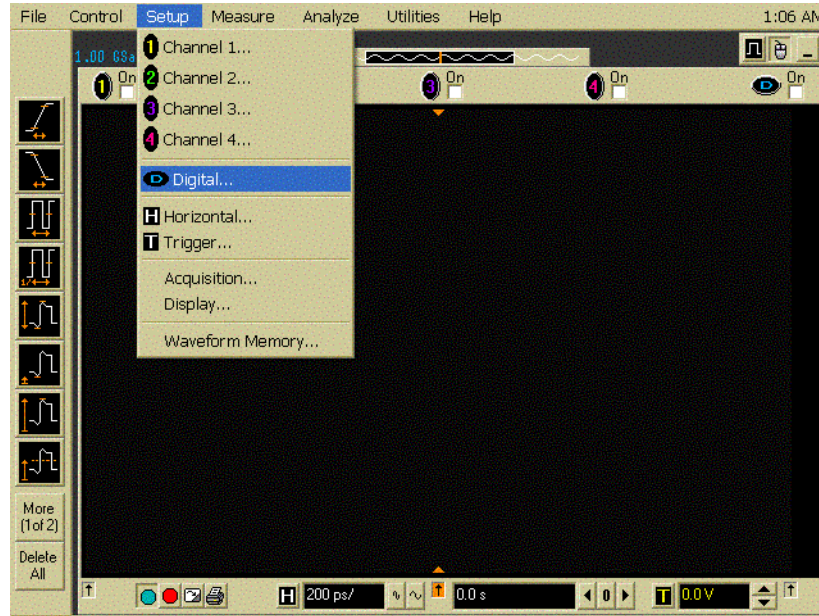

- d Ensure that Enable tab is selected. Ensure that the On checkboxes for all 16 bits have check marks.

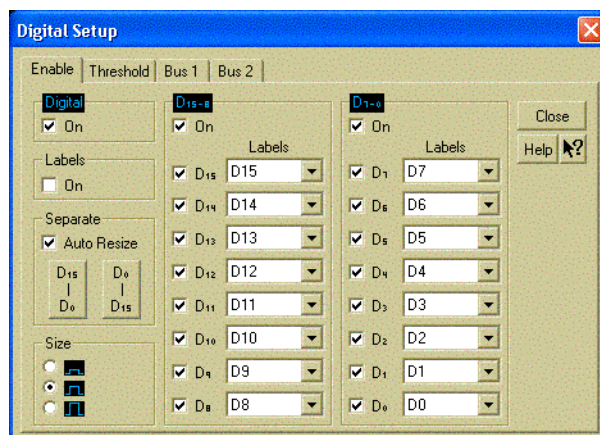

- e Close the Digital Setup window.

Chapter 3: Testing Performance  
**To verify threshold accuracy**

**f** Select Measure from the menu bar and then select Markers...

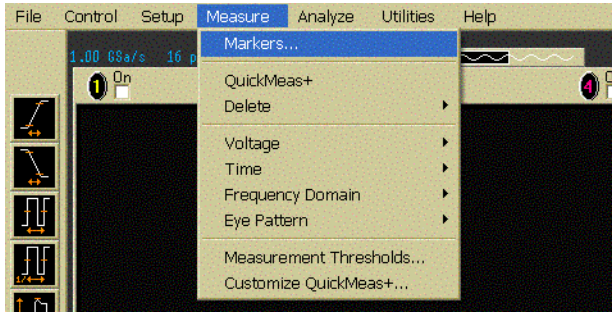

**g** Set the mode to Track Waveforms.

**h** Set the position of both markers to center screen by selecting the 0 buttons for each marker.

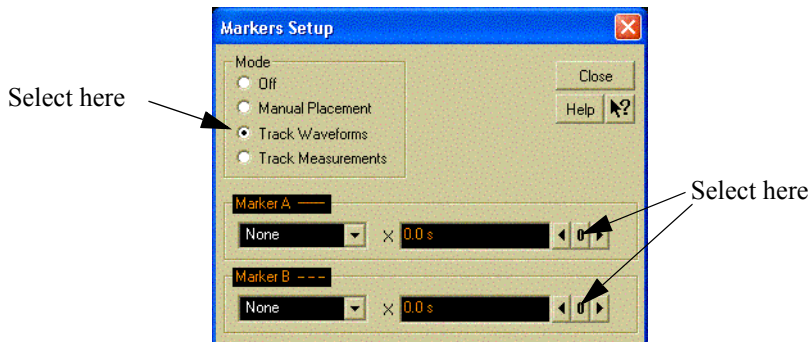

**i** Close the Marker Setup window.

**j** Display the states of the digital bits at the markers in both hexadecimal and binary forms by selecting the Logic tab in the marker display area at the bottom of the LCD display.

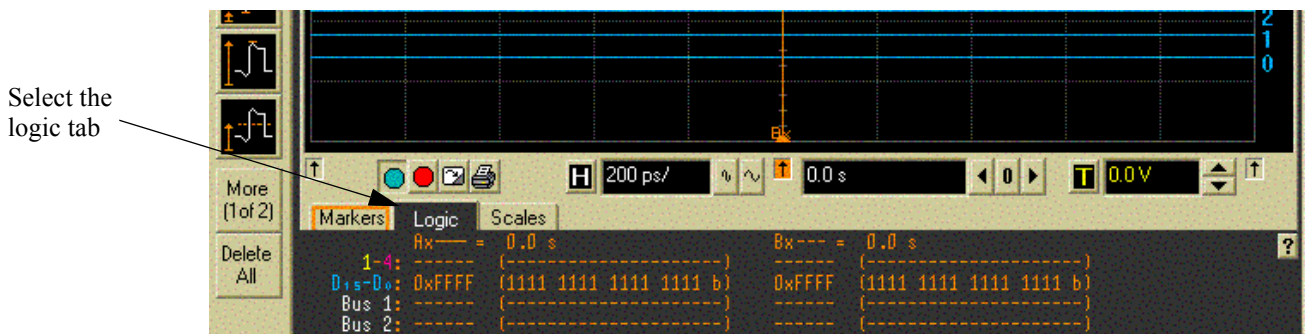

Note: The data in the left column shows the states of the digital inputs at the Cursor A position and the data in the right column shows the states of the digital inputs at the Cursor B position.

**k** Set the oscilloscope digital threshold to the value being tested (e.g. +5V, 0V or -5V) as follows:

From the menu bar, select Setup, then select Digital..., then select the Threshold tab. Make the following settings for both pods:

Set the Logic Family to User Defined.

Set the Threshold for both pods to the value being tested. Start with the first value of

“Oscilloscope Threshold Voltage Setting” in Table 1 on page 55.

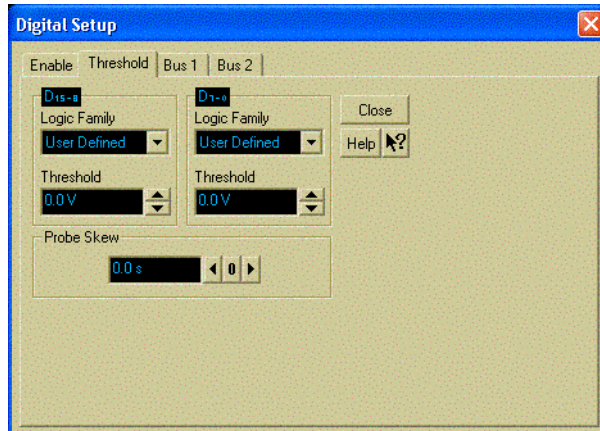

Close the Digital Setup dialog.

**1** Set the horizontal time scale.

Select the horizontal scale setting (near the bottom of the display).

In the Enter Scale dialog, enter either 200 or 500 and then select p.

- For MSO/DSO8064A models, enter 500 and then select p.
- For MSO/DSO8104A models, enter 200 and then select p.

Select horizontal scale setting

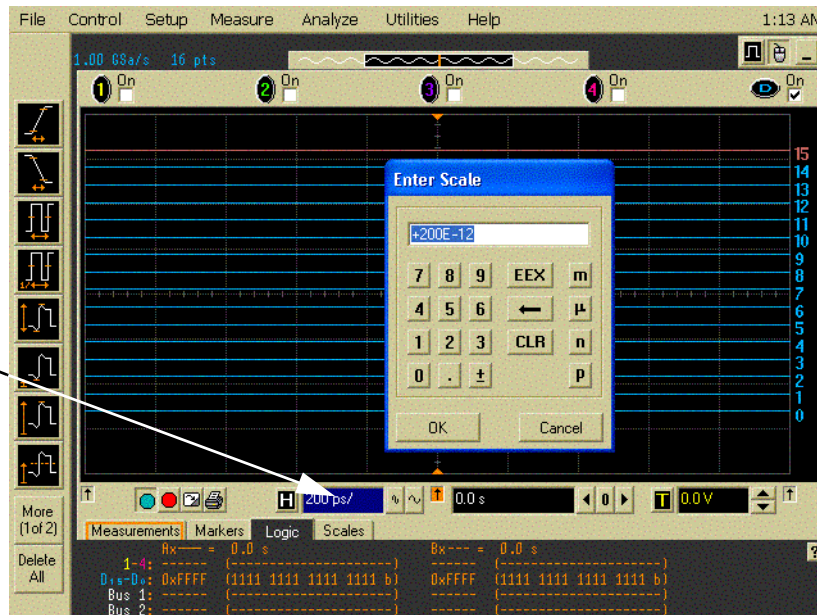

Chapter 3: Testing Performance  
To verify threshold accuracy

- 5 Set up the Acquisition system as follows:
  - a Select Setup from the menu bar, and then select Acquisition...



- b Set the analog memory depth.  
Select Manual in the Analog Memory Depth pane.  
Set the number of points to 16.

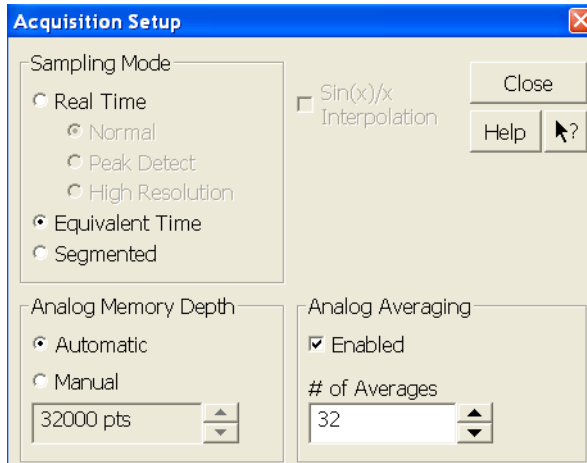

Note: Minimizing acquisition memory depth allows the oscilloscope to display changing inputs more quickly and this reduces the chance for making an error in this procedure.  
Close the Acquisition Setup dialog.

- c Select Setup from the menu bar, and then select Trigger.... Ensure that the trigger mode is set to Edge and Sweep is set to Auto.

## High-to-Low Transitions

- 1 Set the DC Signal Source voltage to the "Initial V1 Setting" as shown in the table below. The DC Signal Source voltage is referred to as "V1" throughout this procedure.

Oscilloscope Threshold Voltage Setting	Initial V1 Setting
+5V	5.35V
0V	200mV
-5V	-4.65V

Table 1: Oscilloscope Threshold Voltage Setting and Initial V1 Setting

Note: In this test, complete steps 2, 3 and 4 for the first threshold voltage setting in the table above. Then set the threshold voltage to the next value in the table and repeat steps 2, 3 and 4 for this threshold voltage setting. Finally, set the threshold voltage to the last value in the table and repeat steps 2, 3 and 4 for the last threshold voltage setting.

- 2 Check the logic display at the bottom of the screen to ensure that all bits are logic 1.

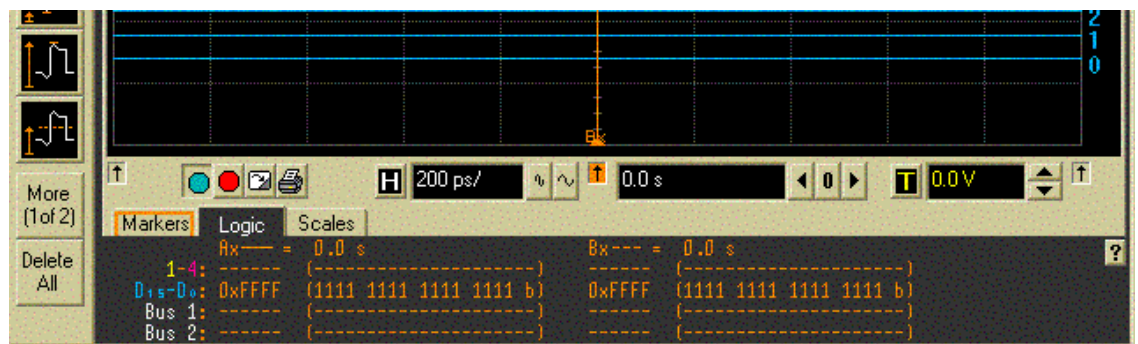

If this is not the case, check the following:

- Read the DMM to determine if the input voltage is correctly set to the "Initial V1 Setting" value shown in Table 1. Adjust the DC Signal Source voltage if necessary.
  - Check the oscilloscope's Digital set up to ensure that the logic threshold voltage is set to the "Oscilloscope Threshold Voltage Setting" value shown in Table 1, and ensure that the display of all bits is enabled.
  - Ensure that the oscilloscope is in Run mode.
  - Ensure that the oscilloscope trigger system is properly configured.
  - If the oscilloscope is set up correctly and the input voltage is accurately set to the initial V1 setting and at least one bit is displayed as 0, then either the oscilloscope is out of calibration or it is malfunctioning. If the oscilloscope has been powered on for at least 30 minutes, recalibrate the oscilloscope and retry this set up.
- 3 Perform the coarse threshold voltage search (to determine the measured threshold voltage within  $\pm 50\text{mV}$ .) You will repeatedly adjust the voltage until all bits change from logic 1 to logic 0. Record the voltage you applied just before all bits switched.
    - a Repeat the following steps until all displayed bits are logic 0:
      - Reduce V1 by 50mV and examine the logic display.
        - If all bits are 0, record the initial value of V1 (the value applied just before all bits switched) as the V2 value in Table 2 and proceed to the Fine Threshold Voltage search.
        - If at least one bit is still 1, reset the input voltage to the initial value of V1 shown in Table 1. This is done so that when V1 is reduced, a significant voltage transition occurs.
      - Reduce V1 by 100mV and examine the logic display.
        - If all bits are 0, record the previous value of V1 (the value at which at least one logic bit was still logic 1) as V2 in the table below. Proceed to the Fine Threshold Voltage search.

Chapter 3: Testing Performance  
**To verify threshold accuracy**

- If at least one bit is still logic 1, reset the input voltage to V1.
- Repeat these steps, decreasing V1 by an additional 50mV for each iteration of the procedure, until all bits are displayed as logic 0. Record the DMM measurement of the last voltage for which at least one bit was logic 1 as V2 in Table 2.

Threshold Voltage Setting	V2
+5V	
0V	
-5V	

Table 2: Threshold Voltage Setting and V2

**4 Perform the fine threshold voltage search (to determine the measured threshold voltage within  $\pm 5\text{mV}$ .)**

- a Repeat the following steps until all displayed bits are logic 0:**
- Reset V1 to the initial value shown in Table 1.
  - Reduce V1 to (V2 - 5mV), and examine the logic display.
    - If all bits are logic 0, stop the test and record the value displayed on the DMM in the Performance Test Record.
    - If at least one bit is still logic 1, reset V1 to the initial value shown in Table 1.
  - Reduce V1 to (V2 - 10mV), then examine the logic display.
    - If all bits are logic 0, then record the value displayed on the DMM in the Performance Test Record.
    - If at least one bit is still logic 1, reset V1 to the initial value shown in Table 1.
  - Repeat these steps, decreasing V1 by an additional 5mV for each iteration of the procedure, until all bits are displayed as logic 0. When all 16 bits have transitioned to logic 0, record the value displayed on the DMM in the Performance Test Record.

## Low-to-High Transitions

- 1 Set the DC Signal Source voltage to the "Initial V1 Setting" as shown in the table below. The DC Signal Source voltage is referred to as "V1" throughout this procedure.

Oscilloscope Threshold Voltage Setting	Initial V1 Setting
+5V	4.65V
0V	-200mV
-5V	-5.35V

Table 3: Oscilloscope Threshold Voltage Setting and Initial V1 Setting

Note: In this test, complete steps 2, 3 and 4 for the first threshold voltage setting in the table above. Then set the threshold voltage to the next value in the table and repeat steps 2, 3 and 4 for this threshold voltage setting. Finally, set the threshold voltage to the last value in the table and repeat steps 2, 3 and 4 entirely for the last threshold voltage setting.

- 2 Check the logic display at the bottom of the screen to ensure that all bits are logic 0. If this is not the case, check the following:
  - Read the DMM to determine if the input voltage is correctly set to the "Initial V1 Setting" value shown in Table 3. Adjust the DC Signal Source voltage if necessary.
  - Check the oscilloscope's Digital set up to ensure that the logic threshold voltage is set to the "Oscilloscope Threshold Voltage Setting" value shown in Table 3, and ensure that the display of all bits is enabled.
  - Ensure that the oscilloscope is in Run mode.
  - Ensure that the oscilloscope trigger system is properly configured.
  - If the oscilloscope is set up correctly and the input voltage is accurately set to the initial V1 setting and at least one bit is displayed as 1, then either the oscilloscope is out of calibration or it is malfunctioning. If the oscilloscope has been powered on for at least 30 minutes, recalibrate the oscilloscope and retry this set up.
- 3 Perform the coarse threshold voltage search (to determine the measured threshold voltage within  $\pm 50\text{mV}$ .) You will repeatedly adjust the voltage until all bits change from logic 0 to logic 1. Then you will record the voltage you applied just before all bits switched.
  - a Repeat the following steps until all displayed bits are logic 1:
    - Increase V1 by 50mV and examine the logic display.
      - If all bits are 1, record the initial value of V1 (the value applied just before all bits switched) as the V2 value in Table 4 and proceed to the Fine Threshold Voltage search.
      - If at least one bit is still 0, reset the input voltage to the initial value of V1 shown in Table 3. This is done so that when V1 is increased, a significant voltage transition occurs.
    - Increase V1 by 100mV and examine the logic display.
      - If all bits are 1, record the previous value of V1 (the value at which at least one logic bit was still logic 0) as V2 in the table below. Proceed to the Fine Threshold Voltage search.
      - If at least one bit is still logic 0, reset the input voltage to V1.
    - Repeat these steps, increasing V1 by an additional 50mV for each iteration of the procedure, until all bits are displayed as logic 1. Record the DMM measurement of the last voltage for which at

Chapter 3: Testing Performance  
**To verify threshold accuracy**

least one bit was logic 0 as V2 in Table 4.

Threshold Voltage Setting	V2
+5V	
0V	
-5V	

Table 4: Threshold Voltage Setting and V2

**4** Perform the fine threshold voltage search (to determine the measured threshold voltage within  $\pm 5\text{mV}$ .)

**a** Repeat the following steps until all displayed bits are logic 1:

- Reset V1 to the initial value shown in Table 3.
- Increase V1 to  $(V2 + 5\text{mV})$ , and examine the logic display.
  - If all bits are logic 1, stop the test and record the value displayed on the DMM in the Performance Test Record.
  - If at least one bit is still logic 0, reset V1 to the initial value shown in Table 3.
- Increase V1 to  $(V2 + 10\text{mV})$ , then examine the logic display.
  - If all bits are 1, then record the value displayed on the DMM in the Performance Test Record.
  - If at least one bit is still 0, reset V1 to the initial value shown in Table 3.
- Repeat these steps, increasing V1 by an additional 5mV for each iteration of the procedure, until all bits are displayed as logic 1. When all 16 bits have transitioned to logic 1, record the value displayed on the DMM in the Performance Test Record.

---

## To test time scale accuracy

### Description

TSA (time scale accuracy) refers to the absolute accuracy of the oscilloscope's time scale. Since TSA depends directly on the frequency of a crystal oscillator, it is comprised of two components; an initial accuracy component and an aging component. The initial accuracy component applies to the scope's accuracy on the date of its shipment to the customer. The aging component scales linearly from the scope's manufacture date and adds to the initial accuracy component.

### Specifications

TSA is published as a warranted specification, expressed by the following formula.

$$\text{TSA} \leq \pm(15 + 2 \cdot (\text{Years Since Manufacture})) \text{ ppm}$$

You can determine the year of manufacture from the oscilloscope's serial number. See "Year of Manufacture" on page 11.

This procedure verifies the maximum TSA specification for the oscilloscope.

---

### Equipment Required

Equipment	Critical Specifications	Recommended Model/Part
Synthesized sine wave source	Output Frequency: 10 MHz Output Amplitude: 0 dBm Frequency Resolution: 0.1 Hz	Agilent E8257 PSG
10 MHz frequency reference	Output Frequency: 10 MHz Output Amplitude: 0 dBm Absolute Freq. Error: < +-0.01 ppm	Symmetricom 58503B
RF cable	50 ohm characteristic impedance (no substitute) BNC (m) connectors Max Frequency: >= 50 MHz	Agilent 8120-1840
Adapters, assorted	3.5 mm (f) to Precision BNC (m) 3.5 mm (f) to 3.5 mm (f)	Agilent 54855-67604 Agilent 83059B

### Connections

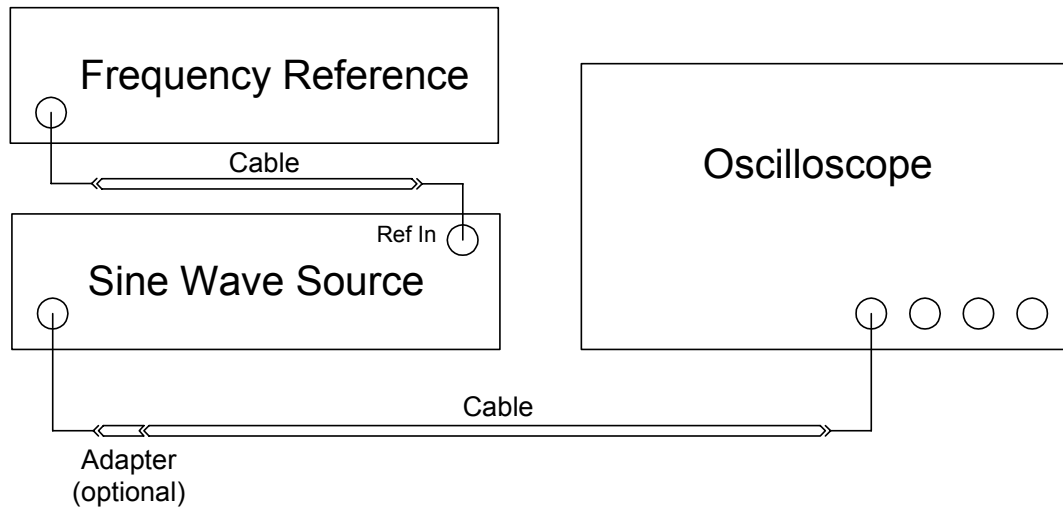

### Procedure

- 1 Configure the sine wave source to output a 0 dBm (600 mVpp) sine wave into 50 ohms with a frequency of 10.0002000 MHz.
- 2 Adjust source amplitude such that displayed sine wave is 600 mVpp.
- 3 Press the **Default Setup** key on the oscilloscope.
- 4 Set channel 1's vertical scale to 100 mV/div.
- 5 Set the oscilloscope sample rate to 100 kSa/s. (The resulting measurement will be aliased.)
- 6 Set the scope's horizontal scale to 10 ms/div.
- 7 Set the scope's input impedance to 50 ohms.
- 8 Set the measurement thresholds for all waveforms to a fixed voltage level of 0 V and  $\pm 20$  mV hysteresis.
- 9 Enable a frequency measurement on channel 1.
- 10 On the oscilloscope, press **Stop**.
- 11 Press **Clear Display**.
- 12 Press **Run**, wait until 10 acquisitions have accumulated, and then press **Stop**.
- 13 Convert the average frequency value to time scale error by subtracting 200 Hz and dividing by 10 Hz/ppm.
- 14 Record the time scale error value as well as the time (in years) since the oscilloscope was manufactured .
- 15 Compare the measured TSA value to the TSA test limits in the Performance Test Record and record the results.

---

## To test delta time measurement accuracy

### Description

DTMA (delta time measurement accuracy) refers to the accuracy of time delay measurements made between two edges of a sine wave acquired on a single scope channel. DTMA depends heavily on whether the waveform is averaged, and is expressed as both an absolute error (peak) and a standard deviation of multiple measurements (rms).

### Specifications

The DTMA specification is shown below. The periods measured by the oscilloscope must fall within the expected value of the period  $\pm$  the value shown in the table. Limits are shown in the Performance Test Record beginning on page 64.

	<b>Delta Time Measurement Accuracy (Maximum)</b>			
	<b><math>\geq 256</math> Averages</b>		<b>No Averaging</b>	
	<b>Absolute (ps peak)</b>	<b>Standard Deviation (ps rms)</b>	<b>Absolute (ps peak)</b>	<b>Standard Deviation (ps rms)</b>
<b>DSO8104 / MSO8104</b>	2.0	0.38	27	5.7
<b>DSO8064 / MSO8064</b>	4.0	1.2	30	6.8

Values apply to period measurements of 0.5 Vpp sine waves with frequencies equal to  $\frac{1}{2}$  the oscilloscope bandwidth at 100 mV/div using  $\geq 2$  GSa/s and sinx/x interpolation.

Chapter 3: Testing Performance  
**To test delta time measurement accuracy**

**Equipment Required**

Equipment	Critical Specifications	Recommended Model/Part
Sine wave source	Output Frequency: 50 MHz to 7 GHz Output Amplitude: -10 dBm to 10 dBm Absolute Frequency Error: < +-1 ppm Period Jitter: < 0.1 times the published typical period jitter of the oscilloscope under test when used with the specified band-pass filter.	Agilent E8257 PSG
Microwave cable assembly	50 ohm characteristic impedance (no substitute) 3.5 mm (m) connectors Max Frequency: >= 18 GHz	Agilent 8120-4948
Adapters, assorted	3.5 mm (f) to Precision BNC (m) 3.5 mm (f) to 3.5 mm (f) SMA (f) to BNC (m)	Agilent 54855-67604 Agilent 83059B Amphenol 901-165
500 MHz Band-pass Filter (for 8104 only)	Center Freq: 500 MHz Pass 3dB BW: 50 MHz Insertion Loss.: 2.1 dB Attn @ 400 MHz: 35 dB Attn @ 600 MHz: 35 dB	K&L Microwave 4LB40-500/T50-O/OP
300 MHz Band-pass Filter (for 8064 only)	Center Freq: 300 MHz Pass 3dB BW: 20 MHz Insertion Loss.: 3.3 dB Attn @ 260 MHz: 36 dB Attn @ 340 MHz: 36 dB	K&L Microwave 4LB40-300/T20-O/OP

**Connections**

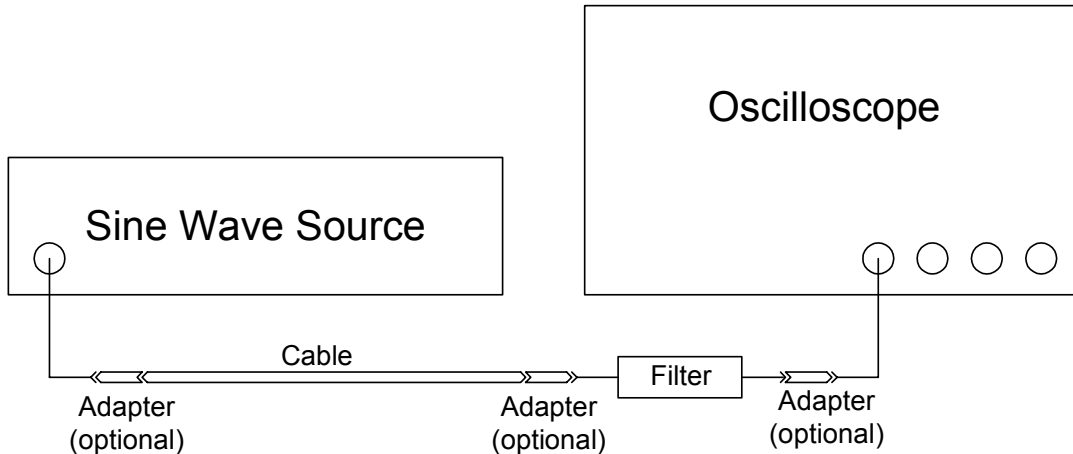

**Procedure**

- 1 Configure the sine wave source to output a 0 dBm (600 mVpp) sine wave into 50 ohms with a frequency that corresponds to the table below.

Oscilloscope Model	Sine Wave Frequency
8104	501 MHz
8064	301 MHz

- 2 Press the **Default Setup** key on the oscilloscope.
- 3 Set the scope's input impedance to 50 ohms.
- 4 Set the channel 1 vertical scale to 100 mV/div.
- 5 Set the scope's horizontal scale to 5 ns/div.
- 6 If necessary, adjust the trigger level until the oscilloscope triggers without auto-triggering.
- 7 Enable waveform averaging, with 16 averages.
- 8 Set the measurement thresholds for all waveforms to a fixed voltage level of 0 V and +- 20 mV hysteresis.
- 9 Enable a peak-to-peak voltage measurement on channel 1.
- 10 Connect the sine wave source through the appropriate band-pass filter to the oscilloscope's channel 1 input, as shown in the diagram above. The appropriate band-pass filter can be found from the table below for each scope model.

Oscilloscope Model	Band-pass Filter Center Frequency
8104	500 MHz
8064	300 MHz

- 11 Adjust the sine wave amplitude until the peak-to-peak voltage of the displayed channel 1 waveform equals 500 mV +- 5 mV. Press **Clear Display** after each adjustment to clear accumulated averages.
- 12 Turn off the peak-to-peak voltage measurement.
- 13 Set the number of waveform averages to 256.
- 14 Set the acquisition memory depth to 65536 points.
- 15 On the oscilloscope, press **Stop**.
- 16 Press **Clear Display**.
- 17 Press **Run**, wait until 256 averages have accumulated, and then press **Stop**.
- 18 Enable jitter mode.
- 19 Enable period measurements on channel 1 using rising edges.
- 20 Record the minimum, maximum, and standard deviation values for the period measurement on channel 1. Compare these values to the test limits for averaged mode DTMA shown in the Performance Test Record.
- 21 Disable waveform averaging.
- 22 Set the trigger mode to single.
- 23 Press **Clear Display**.
- 24 Press **Run**.
- 25 Record the minimum, maximum, and standard deviation values for the period measurement on channel 1. Compare these values to the test limits for non-averaged mode DTMA shown in the Performance Test Record.
- 26 Repeat steps 2 through 25 for channels 2, 3, and 4.

Performance Test Record

<h2 style="margin: 0;">Agilent Technologies</h2>		<b>Agilent 8000 Series Oscilloscopes</b>			
Model Number _____		Tested by _____			
Serial Number _____		Work Order No. _____			
Recommended Test Interval - 1 Year/2000 hours		Date _____			
Recommended next test date _____		Ambient temperature _____			
<b>Test</b>	<b>Limits</b>	<b>Results</b>			
	(Vmax - Vmin)/4.8 =Limits				
<b>DC Calibrator Amplitude</b>	1.000                      0.998 to 1.002	_____			
<b>Input Resistance</b>	50 Ω                      49.25 Ω to 50.75 Ω	<b>Channel 1</b>	<b>Channel 2</b>	<b>Channel 3</b>	<b>Chan 4/Ext</b>
	1 MΩ                      990 kΩ to 1.010 MΩ	_____	_____	_____	_____/____
		_____	_____	_____	_____/____
<b>Time Scale Accuracy</b>	<b>Limit</b> Limit is based on oscilloscope's age  TSA ≤ ± (15 + 2 * YrsSinceMfr) ppm	<b>Calculated TSA Spec</b>	<b>Measured time scale error</b>	<b>Pass/Fail</b>	
		_____	_____	_____	
<b>MS08064A, DS08064A Delta Time Measurement Accuracy</b>	<b>Limits</b>	<b>Results</b>			
	Averaged Mode DTMA	<b>Channel 1</b>	<b>Channel 2</b>	<b>Channel 3</b>	<b>Channel 4</b>
	Maximum (ps)              3326.2	_____	_____	_____	_____
	Minimum (ps)              3318.3	_____	_____	_____	_____
	Std. Deviation (ps rms)    1.2	_____	_____	_____	_____
	Non-Averaged Mode DTMA	<b>Channel 1</b>	<b>Channel 2</b>	<b>Channel 3</b>	<b>Channel 4</b>
	Maximum (ps)              3352.2	_____	_____	_____	_____
	Minimum (ps)              3292.3	_____	_____	_____	_____
Std. Deviation              6.8	_____	_____	_____	_____	
<b>MS08104A, DS08104A Delta Time Measurement Accuracy</b>	<b>Limits</b>	<b>Results</b>			
	Averaged Mode DTMA	<b>Channel 1</b>	<b>Channel 2</b>	<b>Channel 3</b>	<b>Channel 4</b>
	Maximum (ps)              1998.0	_____	_____	_____	_____
	Minimum (ps)              1994.0	_____	_____	_____	_____
	Std. Deviation              0.38	_____	_____	_____	_____
	Non-Averaged Mode DTMA	<b>Channel 1</b>	<b>Channel 2</b>	<b>Channel 3</b>	<b>Channel 4</b>
	Maximum (ps)              2023.0	_____	_____	_____	_____
	Minimum (ps)              1969.0	_____	_____	_____	_____
Std. Deviation (ps rms)    5.7	_____	_____	_____	_____	

Test	Limits			Results			
<b>Single Cursor Voltage Measurement Accuracy with Offset</b>	<b>Range</b>	<b>Supply</b>	<b>Limits</b>	<b>Channel 1</b>	<b>Channel 2</b>	<b>Channel 3</b>	<b>Channel 4</b>
	5 V/div	35 V	33.48 V to 36.52 V	_____	_____	_____	_____
	2 V/div	14 V	13.39 V to 14.61 V	_____	_____	_____	_____
	1.25 V/div	8.75 V	8.17 V to 9.33 V	_____	_____	_____	_____
	500 mV	3.5 V	3.35 V to 3.65 V	_____	_____	_____	_____
	250 mV	1750 mV	1.61 V to 1.89 V	_____	_____	_____	_____
	100 mV	700 mV	669 mV to 731 mV	_____	_____	_____	_____
	50 mV	350 mV	334 mV to 366 mV	_____	_____	_____	_____
	20 mV	140 mV	133 mV to 147 mV	_____	_____	_____	_____
	10 mV	70 mV	66.0 mV to 74.0 mV	_____	_____	_____	_____
5 mV	35 mV	32.5 mV to 37.5 mV	_____	_____	_____	_____	
<b>Bandwidth</b>			<b>Down from reference:</b>	<b>Channel 1</b>	<b>Channel 2</b>	<b>Channel 3</b>	<b>Channel 4</b>
	<b>Equivalent Time</b>						
	MSO/DSO8064A		<3.0 dB at 600 MHz	_____	_____	_____	_____
	MSO/DSO8104A		<3.0 dB at 1 GHz	_____	_____	_____	_____
<b>Real Time</b>							
MSO/DSO8064A		<3.0 dB at 600 MHz	_____	_____	_____	_____	
MSO/DSO8104A		<3.0 dB at 1 GHz	_____	_____	_____	_____	
<b>Digital Channels Threshold Accuracy (MSO models only)</b>	<b>±100 mV +3% of threshold setting</b>			<b>Results</b> _____ _____ _____ _____ _____ _____ _____ _____ _____ _____			
	<b>High-to-Low Transitions</b>						
	<b>Threshold Voltage</b>	<b>Limits</b>					
	5 V	4.750 V to 5.25 V					
	0 V	-100 mV to 100 mV					
	-5 V	-5.25 V to -4.75 V					
	<b>Low-to-High Transitions</b>						
	<b>Threshold Voltage</b>	<b>Limits</b>					
	5 V	4.750 V to 5.25 V					
	0 V	-100 mV to 100 mV					
-5 V	-5.25 V to -4.75 V						



Self Calibration Interval 68  
Calibration Procedures 68  
To run the self calibration 69

---

# Calibrating and Adjusting

This chapter provides the self-calibration procedure for the Agilent Technologies 8000 Series oscilloscope.

## Hardware Adjustments

There are no hardware adjustments required for the 8000 Series oscilloscope.

## Self Calibration Interval

The firmware calibration is the self cal (self calibration). Self calibration should be done every year, or every 2,000 hours of operation, whichever comes first.

The self calibration uses signals generated in the oscilloscope to calibrate channel sensitivity, offsets, and trigger parameters. You should run the self calibration

- yearly, or according to your periodic needs,
- when you adjust or replace the acquisition assembly or acquisition hybrids,
- when you replace the hard drive or any other assembly,
- when the delta temperature is more than  $\pm 5$  °C different than the last calibration, or
- after performing incoming performance verification and before performing outgoing performance verification.

The need for self calibration will also depend on the environment in which you use the oscilloscope.

## Calibration Procedures

The procedures start with the next paragraphs. Unless specified elsewhere, procedures must be followed in the order given. Display checks are optional and independent of other procedures.

---

**WARNING****SHOCK HAZARD!**

Read the Safety information at the back of this guide before performing adjustment procedures. Failure to observe safety precautions may result in electrical shock.

---

---

**WARNING****INJURY CAN RESULT!**

Install the fan safety shield (included in the Service Kit) if you remove the oscilloscope cover. Without this shield, the oscilloscope fan blades are exposed and can cause injury.

---

---

## To run the self calibration

---

### Equipment Required

---

Equipment	Critical Specifications	Recommended Model/Part
Adapters (2)	BNC (f) to BNC (m) right angle	Agilent 1250-0076
Cable	BNC 50 $\Omega$	Agilent 8120-1839

#### **Let the Oscilloscope Warm Up Before Running the Self Calibration**

The self calibration should only be done after the oscilloscope has run for 30 minutes at ambient temperature with the covers installed.

#### **Calibration time**

It will take approximately 45 minutes to run the self calibration on the oscilloscope, including the time required to change cables from channel to channel.

- 1 Select Calibration from the Utilities menu.
- 2 If the Cal Memory Protect box in the Calibration dialog is checked, select the check box to clear the check mark.

See Figure 4-1.

Figure 4-1

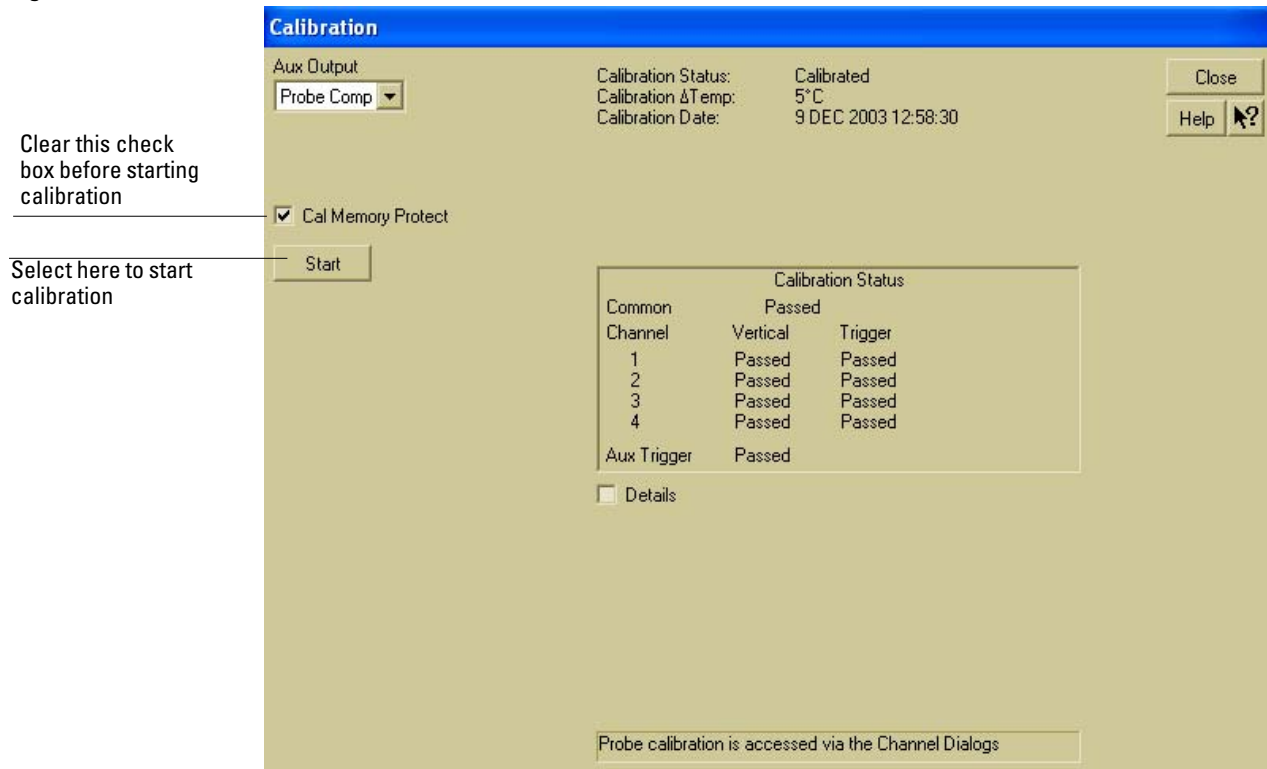

Calibration Dialog

**Clear Cal Memory Protect to Run self calibration**  
You cannot run self calibration if this box is checked.

- 3 Connect an adapter to each end of the cable.
- 4 Select Start, then follow the instructions on the screen.  
You will be asked first to disconnect all channels and the Aux Output (located on the rear panel of the oscilloscope), then to connect Aux Out to each channel and the auxiliary trigger in turn. After you complete each cable change, select OK in the dialog box to continue the calibration. The oscilloscope displays a Passed/Failed message as each calibration routine is completed.
- 5 Select Close.

**If calibration fails**  
Go to chapter 5 "Troubleshooting."

Safety	72
Tools Required	72
ESD Precautions	72
Keystroke Conventions	72
Default Setup	73
To install the fan safety shield	73
To troubleshoot the oscilloscope	74
Primary Trouble Isolation	76
No Display Trouble Isolation	79
Power Supply Trouble Isolation	83
To check probe power outputs	85
To Check the keyboard	86
To check the LEDs	87
To check the motherboard, CPU, and RAM	88
To check the display board video signals	82
To check the backlight inverter voltages	81
To setup the BIOS	91
To troubleshoot the acquisition system	92
Software Revisions	94

---

# Troubleshooting

This section provides troubleshooting information for the Agilent Technologies 8000 Series oscilloscope. The service strategy of this oscilloscope is replacement of defective assemblies.

## Safety

Read the Safety Summary at the front of this manual before servicing the oscilloscope. Before performing any procedure, review it for cautions and warnings.

---

### WARNING

#### SHOCK HAZARD!

Maintenance should be performed by trained service personnel aware of the hazards involved (for example, fire and electric shock). Lack of training and awareness of the hazards could result in electrical shock. When maintenance can be performed without power applied, the power cord should be removed from the oscilloscope.

---

---

### WARNING

#### MOVING PARTS HAZARD!

Use caution when working around the cooling fans when the cover has been removed from the oscilloscope. The cooling fan blades are exposed on one side and can be hazardous. Install the optional fan safety shield (Agilent Technologies P/N 54810-00601) to protect your fingers from the fan blades.

---

## Tools Required

You will need basic electronic troubleshooting tools, including a digital multimeter and a 100-MHz (or faster) oscilloscope.

See Chapter 6, “Replacing Assemblies,” if you need to remove and replace assemblies.

## ESD Precautions

When using any of the procedures in this chapter, you must use proper ESD precautions to protect the oscilloscope components from ESD damage. Failure to follow proper ESD control procedures may cause immediate failure or latent damage. Latent damage may result in equipment failure after a period of time. As a minimum, you should place the oscilloscope on a properly grounded ESD mat and wear a properly grounded ESD wrist strap when working on the oscilloscope.

## Keystroke Conventions

To guide you while setting up the oscilloscope, the following conventions are used to represent keystrokes and other interactions with the oscilloscope:

- When you need to issue a command through the graphical interface, the command will be phrased like this: “Select <command> from the <menu name> menu.”
- When you need to select an object on the graphical interface, the instructions will be phrased something like this: “Select the OK button.”
- When you need to press a key, the instructions will be phrased something like this: “Press the Run key.”

### Default Setup

A Default Setup is provided to ensure that the oscilloscope is in a known state. The default setup prevents previous setups from interfering with the next test. It also simplifies the oscilloscope setup procedure. Use the default setup when a procedure requires it.

- Press the Default Setup key to set the oscilloscope to the default state.

---

## To install the fan safety shield

- 1 Disconnect the oscilloscope power cord and remove the cover.  
See Chapter 6, “Replacing Assemblies,” if you need to remove and replace assemblies.
- 2 Clip the fan safety shield over the outside of the oscilloscope chassis next to the fans.  
See See Figure 5-1.

Figure 5-1

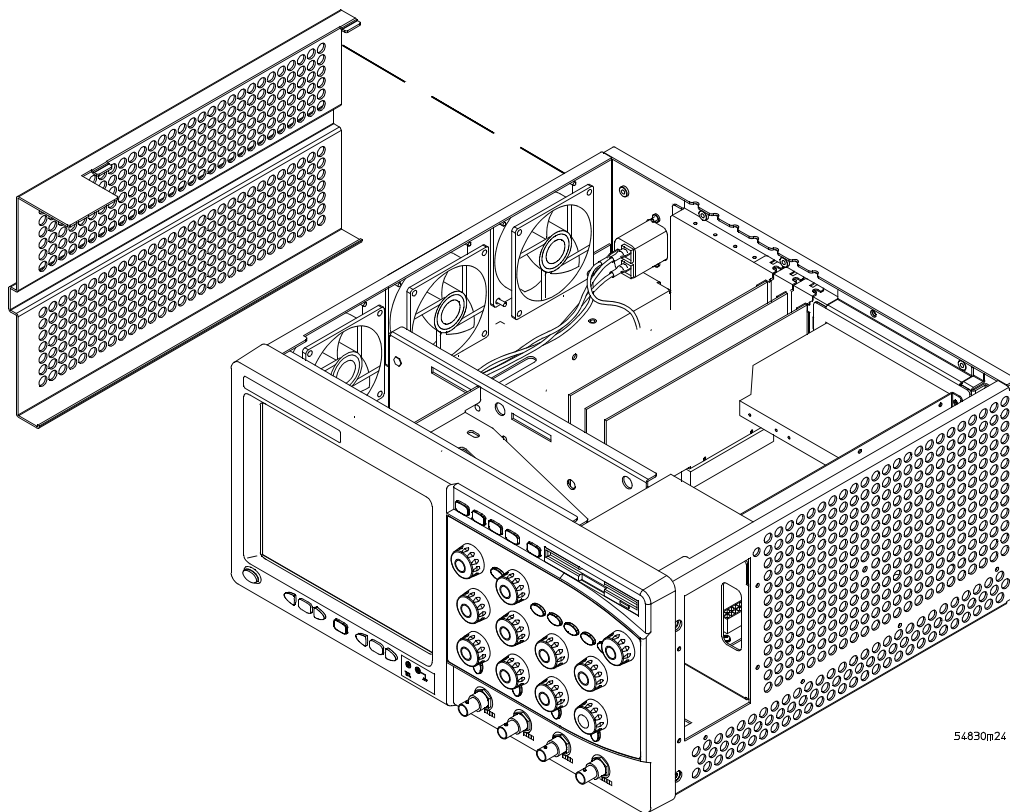

Installing the Fan Safety Shield

## To troubleshoot the oscilloscope

The troubleshooting procedure is used to isolate problems to a faulty assembly. When you find the faulty assembly, use the disassembly and assembly procedures in chapter 6 to replace the assembly.

The primary procedural tool in this section is the flowchart. The flowchart contains the entire troubleshooting path from a failed oscilloscope to a working one, and will direct you in an orderly manner through the possible failure symptoms. Reference letters on the flowcharts point to procedural steps that explain the brief instructions in the chart. Do not try to troubleshoot by following only the reference text because the text is not in the correct order for troubleshooting. Instead, simply follow the flowchart.

If you are unfamiliar with this oscilloscope, start with the Primary Trouble Isolation Flowchart on the next page.

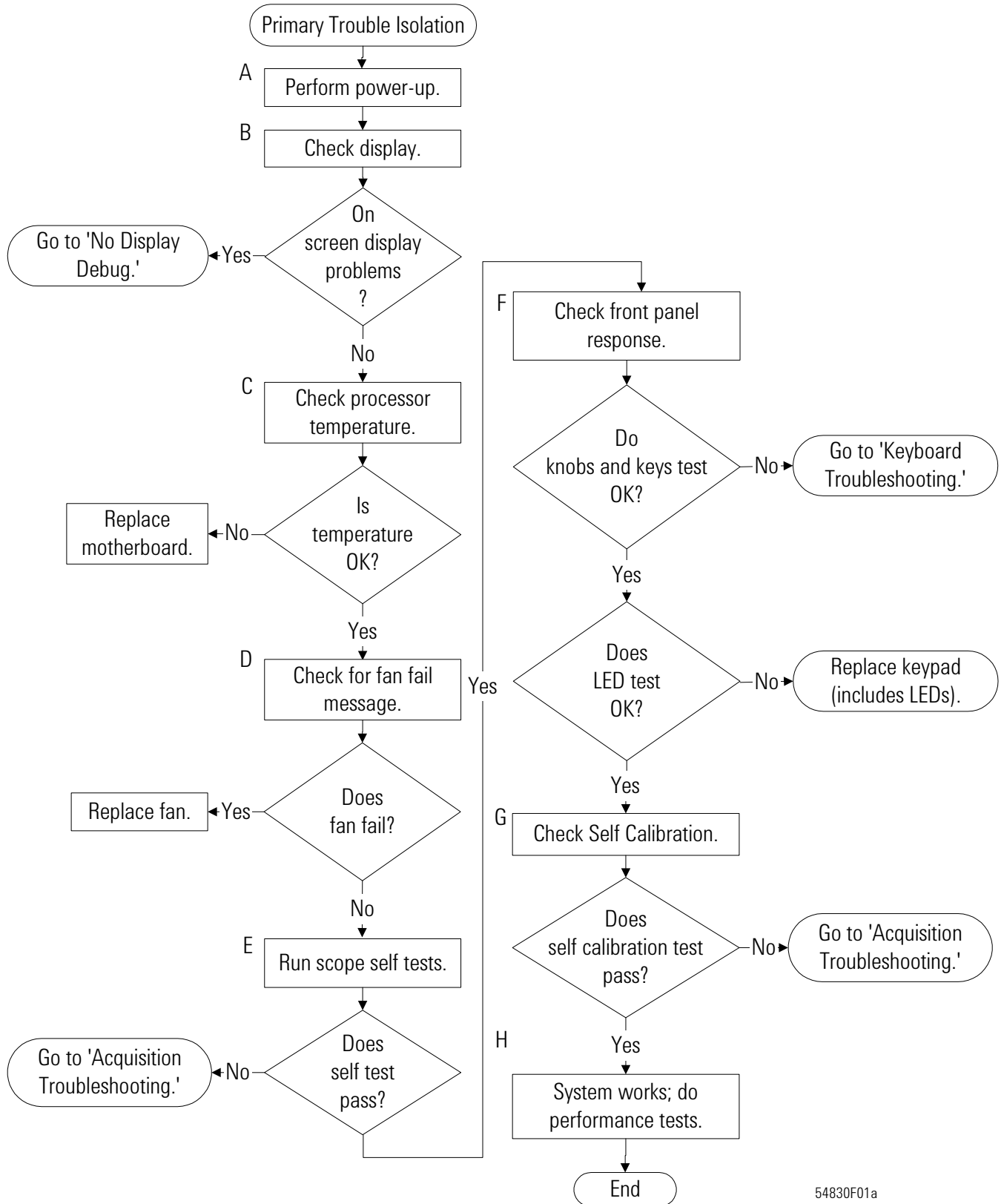

54830F01a

**Primary Trouble Isolation Flowchart**

## Primary Trouble Isolation

The actions in the Primary Trouble Isolation are done without disassembling the oscilloscope. Interaction of the front panel with the rest of the oscilloscope and other indicators are used to help identify the problem area.

A letter is assigned to boxes in the flowchart. The letter corresponds to a specific section in the reference text. Be sure to use the flowchart itself for your troubleshooting path.

### A Perform power-up.

#### 1 Power-on the oscilloscope.

A short time after the oscilloscope is turned on, the oscilloscope graticule is displayed on the screen. The screen should look similar to the next figure. The exact appearance may vary depending on the setup selected before the oscilloscope was turned off.

Figure 5-2

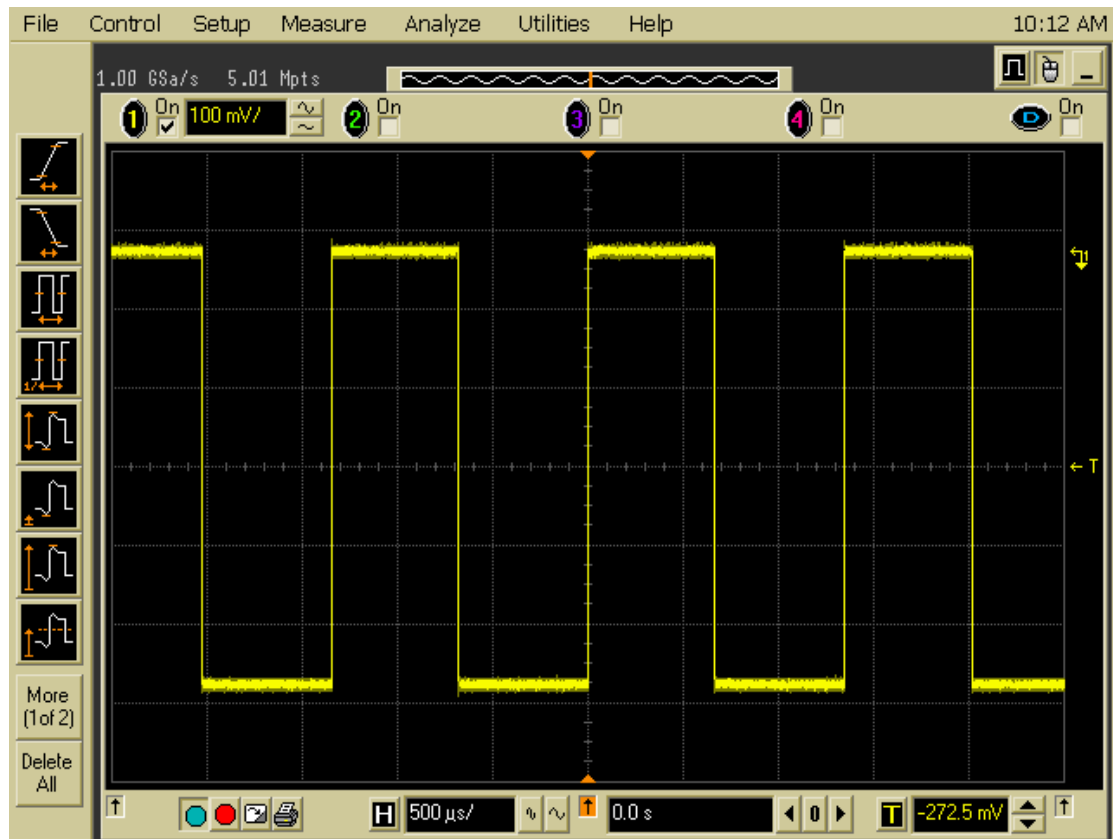

#### Power-on Display Default (Graphical Interface Disabled)

#### 2 Press the Default Setup key.

### B Check the display.

The display on the screen should be similar to the figure above. If there is no display on the oscilloscope flat-panel display after power-up, go to the No Display Trouble Isolation Flowchart otherwise go to step C.

**C Run oscilloscope self-tests.**

- 1 Select Self Test from the Utilities menu.
- 2 Select oscilloscope Self Tests from the Self Test drop down list box.
- 3 Select the Start Test button and follow the instructions on the screen.

If any of the Self Tests fail, go to the Acquisition Trouble Isolation troubleshooting flowchart later in this chapter for further troubleshooting. Otherwise, go to step D.

**D Check the front panel response by running the knob, key, and LED self tests.**

Use this procedure to verify correct keyboard operation.

- 1 Select Self Test from the Utilities menu.
- 2 Select Knob and Key from the Self Test drop down list box, then select Start.

A new window appears with a symbolic representation of the keyboard. See See Figure 5-3.

**Figure 5-3**

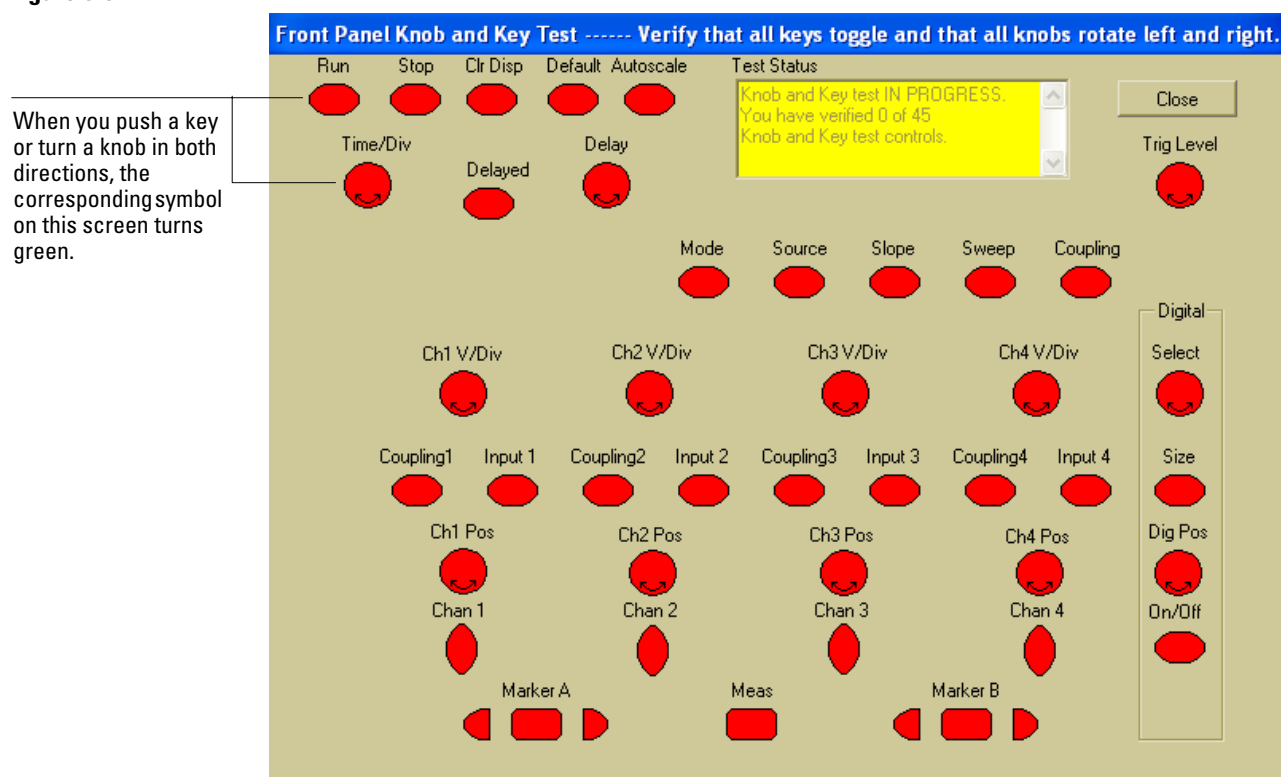

**Knob and Key Self Test Screen**

**3 Push each key on the keyboard until you have pushed all keys.**

When you push a key, the corresponding key symbol on the display should change from red to green.

**4 Turn each knob in both directions until you have turned all knobs.**

When you turn a knob in one direction, the corresponding knob symbol on the display should change from red to yellow. When you then turn the knob in the other direction, the knob symbol should change from yellow to green.

**5 When you are finished, select Close.**

If any of the knobs or keys do not work, see “To Check the keyboard” on page 86.

Chapter 5: Troubleshooting  
**Primary Trouble Isolation**

Use the following procedure to test the front-panel LED (light-emitting diode) indicators.

- 1 Enable the graphical interface.
- 2 Select Self Test from the Utilities menu.
- 3 Select LED from the Self Test drop-down list box, then select Start Test.

The LED test screen appears, which shows a symbolic representation of all front panel LED indicators. See See Figure 5-4.

**Figure 5-4**

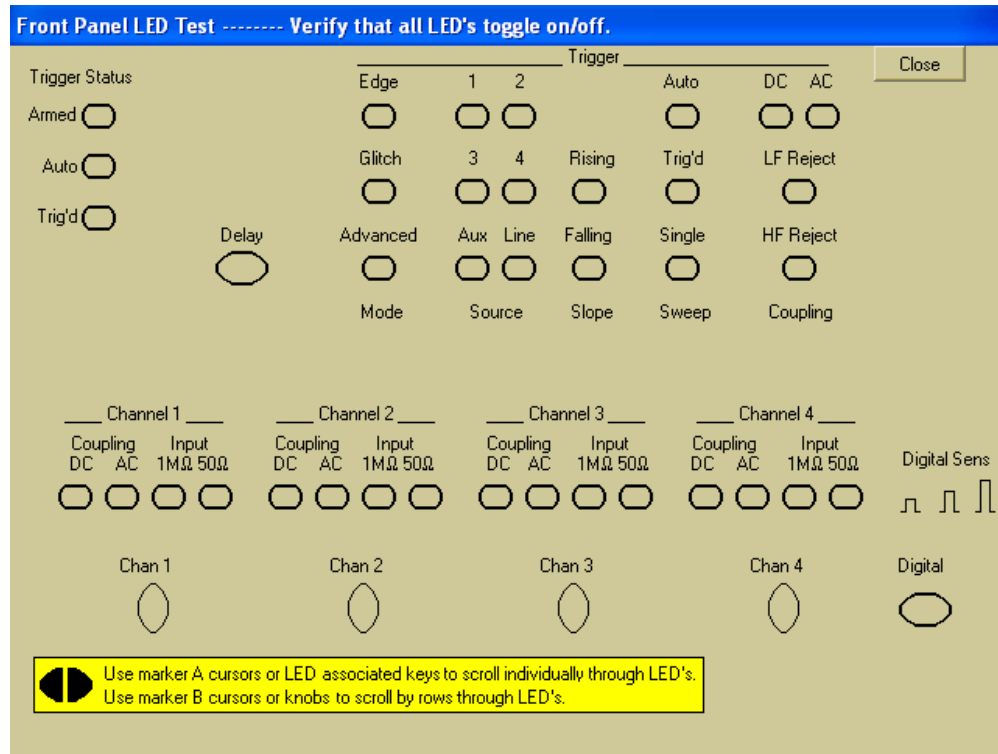

**LED Test Screen**

- 4 Push the Marker A left and right arrow keys to highlight each LED symbol in the test screen. Verify that the corresponding LEDs on the front panel are the only ones illuminated.

**Test by Rows**

You can use the Marker B arrow keys to test LEDs by row; however, in the event that two LED indicators are shorted together, there is a small chance that the test will not reveal the failure.

- 5 When you are finished, select Close.  
 If any of the LEDs do not work, see “To check the LEDs” on page 87.
  - 6 If both tests pass, go to step E.
- E Self Calibration**
- 1 Complete a self Calibration by following the procedures. See “Testing Performance” on page 37.
  - 2 If the calibration test fails, replace the acquisition assembly. If the calibration test passes, go to step F.
- F The system is operational. Performance test the oscilloscope. See “Testing Performance” on page 37.**

---

## No Display Trouble Isolation

This trouble isolation procedure helps isolate a problem to the assembly level when there is no display on the flat-panel liquid crystal display screen.

**A Remove the cabinet and install the fan safety shield.**

- 1 Disconnect the power cord from the oscilloscope. See Chapter 6, “Replacing Assemblies,” for instructions on removing the cabinet. Use care in handling the oscilloscope.
- 2 Install the optional fan safety shield, Agilent Technologies P/N 54810-00601, over the fans on the left side of the oscilloscope.

---

**WARNING**

**SHOCK HAZARD!**

The backlight inverter assembly, which is mounted at the front corner of the oscilloscope near the flat-panel display, operates at 900 V at turn on. DO NOT handle this assembly while it is in operation.

---

**WARNING**

**INJURY CAN RESULT!**

Once the cover is removed, the fan blades are exposed both inside and outside the chassis. Disconnect the power cable before working around the fan. Use extreme caution in working with the oscilloscope when the cover is removed. Install the fan safety shield (Agilent Technologies P/N 54810-00601) on the side of the chassis over the fan. Failure to observe these precautions may result in injury.

---

**B Check the fan connections.**

Verify that all fans are connected.

- 1 The oscilloscope fans connect to the fan controller board on the bottom deck A20.
  - 2 The CPU fan connects to the top side of the motherboard noted “CPU Fan.”
  - 3 The Power Supply fan is at the rear of the power supply.
  - 4 Connect the power cord and press the power switch on the front panel. Verify that all fans are running and that the front panel power switch LED is illuminated. These are indications that the power supply is functioning. If the fans and LED are off, go to the Power Supply Trouble Isolation flowchart. Otherwise go to step C.
- C** Connect an external monitor, cycle power, and observe the following oscilloscope power-on sequence. If the power-up on external monitor test fails go to step D.
- D** Replace Display Card (Agilent Technologies P/N 0960-2530). If the display is still having problems go to step E.
- E** Replace the motherboard assembly A19.

Chapter 5: Troubleshooting  
**No Display Trouble Isolation**

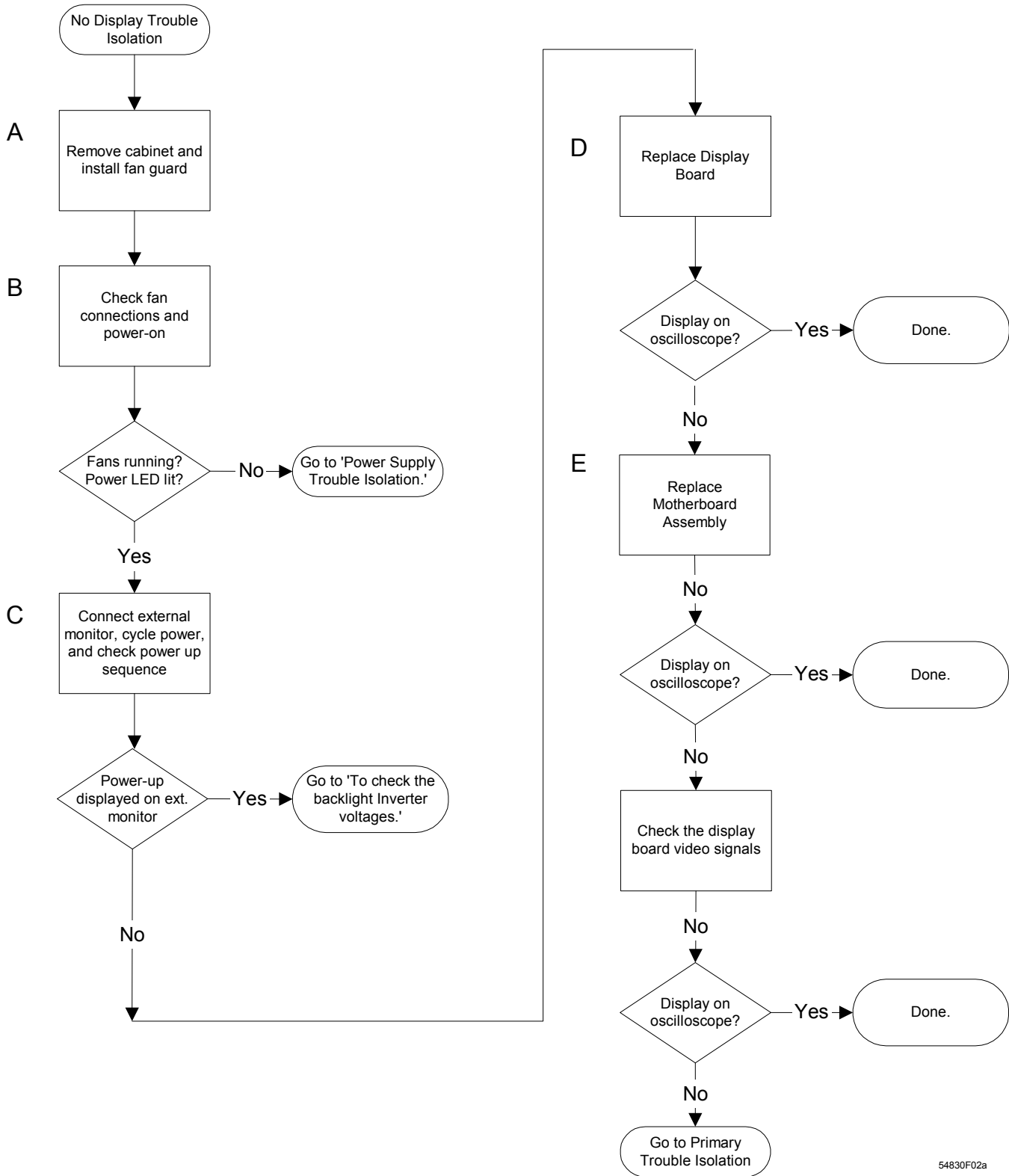

54830F02a

**No Display Trouble Isolation Flowchart**

---

## To check the backlight inverter voltages

The backlight inverter board A5 is located in the front-left corner of the oscilloscope (as you face the front panel).

- There is an input connector at one side of the board.
- There are two output connectors on the other end of the board, that power the two backlights which are inserted into the flat panel display.

The output voltage is approximately 300-450 V<sub>rms</sub>, 40 kHz (measured differentially between the two wires) when the backlight is illuminated. The voltage is approximately 1 kV before the backlight tube is illuminated. A red LED on the backlight inverter board illuminates when the output voltage is present.

When the backlight goes off (when the oscilloscope's operating system switches to screen saver mode) the voltage on pins 1 and 2 (with respect to ground) slowly decays to 0 V.

The outputs are controlled by the input. Notice that input pin 5 goes low to enable the output voltage. These pins can be reached at J1 on the display board A11 on systems that use the Intel motherboard, or on connector CN10 on systems that use the ADLINK motherboard.

**Table 5-5**

**Backlight Inverter Board Input Voltages**

---

Input Pin #	7	6	5	4	3	2	1
Backlight OFF	0 V	0 V	0 V	0 V	0 V	0 V	0 V
Backlight ON	5 V	0 V	2.5 V	0 V	0 V	12 V	12 V

---

## To check the display board video signals

(Note that systems that use the ADLINK M880 motherboard do not have a display board. The display board is integrated with the M880 motherboard.)

The video signals are checked on the 32-pin connector J2 on the display board A12. You can use an oscilloscope with a bandwidth of at least 100 MHz to verify the signals. Even-numbered pins are closest to the PC board. If the signals are not present, suspect the display card. If the signals are present and the backlights are on, suspect the flat-panel display as the problem. Note that CLK, A0, A1, A2, and A3 are Low Voltage Differential Signals (LVDS).

**Table 5-6**

**Video Signals**

Pin Number	Signal	Pin Number	Signal
1	NC	26	NC
2	CLK-	27	NC
3	CLK+	28	NC
4	GROUND	29	NC
5	A3-	30	NC
6	A3+	31	NC
7	GROUND	32	NC
8	A2-		
9	A2+		
10	GROUND		
11	A1-		
12	A1+		
13	GROUND		
14	A0-		
15	A0+		
16	NC		
17	NC		
18	NC		
19	NC		
20	NC		
21	GROUND		
22	GROUND		
23	+3.3 V		
24	+3.3 V		
25	+3.3 V		

**Power Supply Trouble Isolation**

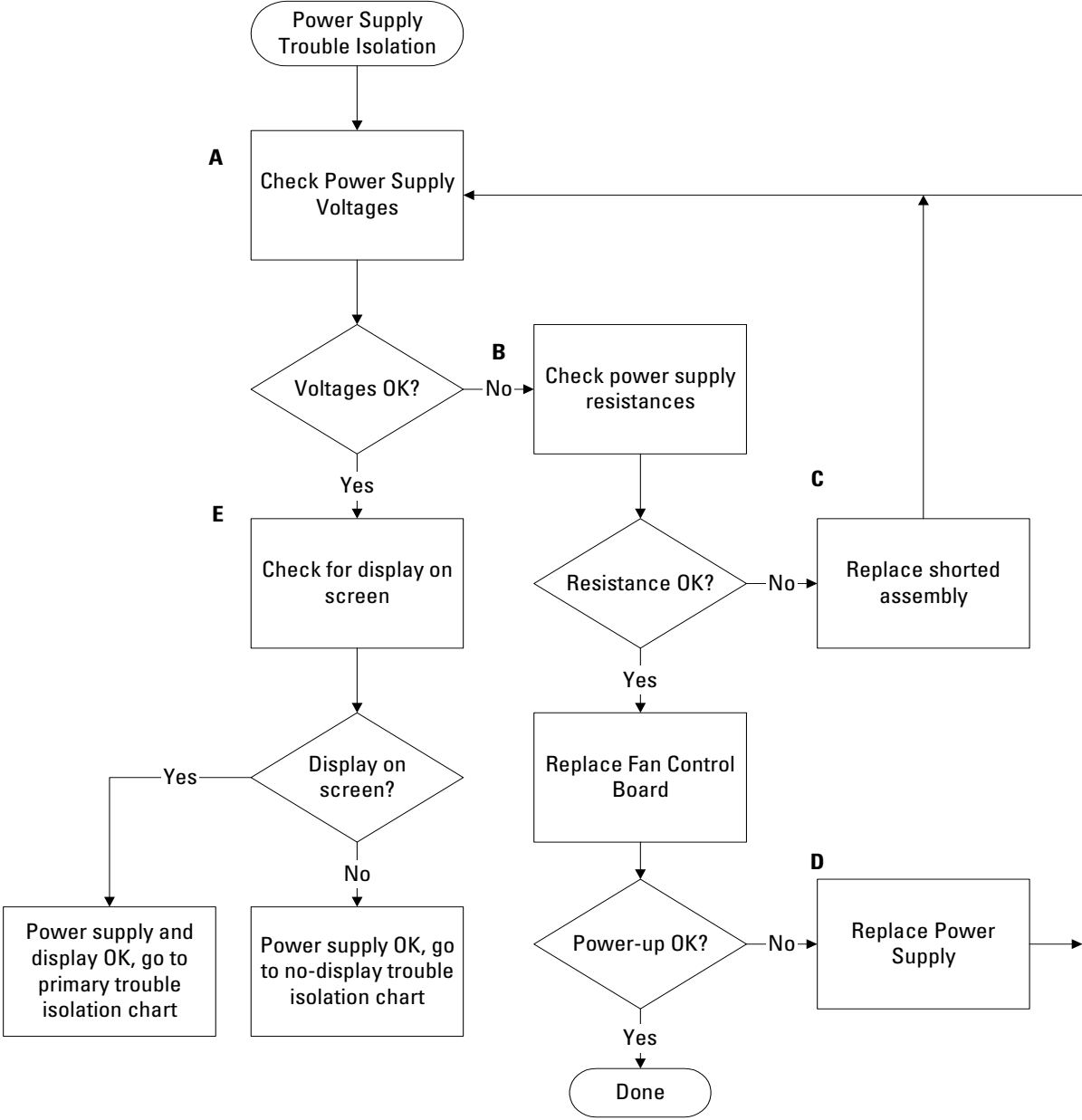

**Power Supply Trouble Isolation Flowchart**

These trouble isolation instructions help isolate the problem to the assembly level when the power supply is not operating. Because of advanced power supply protection features, the problem may not be with the supply itself, and therefore you will need to work through the procedure systematically to determine the source of the fault.

**A Check the power supply voltages.**

The power supply voltages are checked on the acquisition board, A13. See See Figure 5-7 for the location of these test points. Table 5-8 shows the allowable range of power supply voltages.

**Figure 5-7**

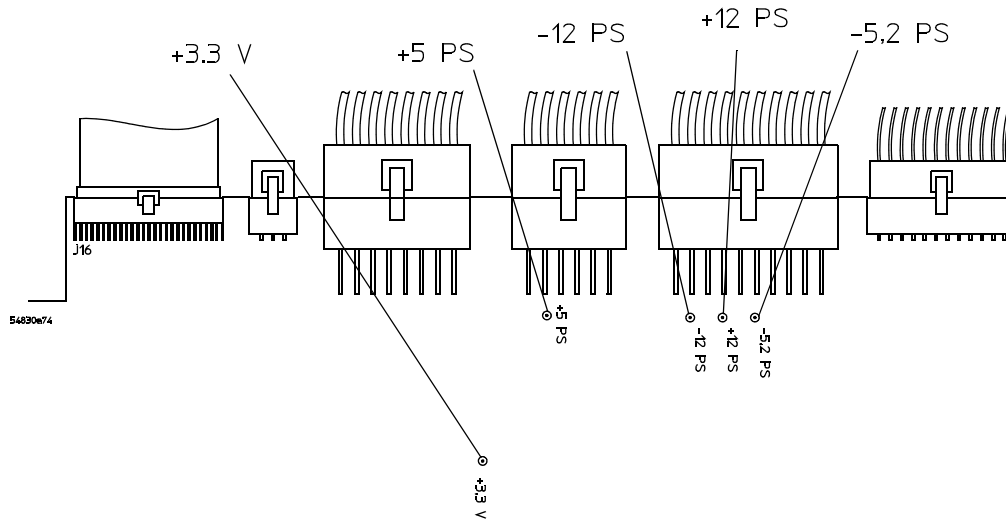

**Power Supply Voltage Test Locations (A13)**

**Table 5-8**

**Power Supply Voltage Limits**

Supply Voltage Specification	Limits
+5.1 V $\pm$ 0.1 V	+5.0 V to +5.2 V
-5.2 V $\pm$ 0.1 V	-5.1 V to -5.3 V
+12.1 V $\pm$ 0.3 V	+11.8 V to +12.4 V
-12.1 V $\pm$ 0.3 V	-11.8 V to -12.4 V
+3.3 V $\pm$ 0.1 V	+3.2 V to + 3.4 V

**B** Turn off the power and measure the power supply resistances to ground to check for shorted supply lines.

You can probe the test points on A13, shown in See Figure 5-7, for this resistance check.

**C** Replace any shorted assembly.

You can locate the shorted assembly by disconnecting assemblies from the power supply, one at a time.

**Reconnect Assemblies and Cables**

Reconnect all assemblies after testing. The oscilloscope must have all cables connected for correct power up.

**D** Replace the power supply.

**1** If there are no shorted assemblies, but the power supply will not power up correctly, replace the power supply. See Chapter 6, “Replacing Assemblies,” for an explanation of how to remove and replace the power supply.

**2** Re-assemble the oscilloscope and apply power.

**E** Check for the oscilloscope display on screen.

**1** You should see the oscilloscope display (See Figure 5-2). If not, see “No Display Trouble Isolation” on page 79.

**2** If you see the display, return to the Primary Trouble Isolation Flowchart.

---

## To check probe power outputs

Probe power outputs are on the front panel, surrounding each BNC input.

Use the table and figure to the right to check the power output at the connectors.

The +12 V and –12 V supplies come directly from the power supply, and the +3 V and –3 V supplies are developed in three-terminal regulators on the probe power & control assembly.

Measure the voltages with respect to the ground terminal on the front panel, located near the Aux Out BNC.

Do not attempt to measure voltages at pins 3 through 7.

Pin	Supply
1	+3V
2	–3V
3	Offset
4	Data
5 & ring	Probe ID
6	Clk
7	R <sub>p</sub>
8	–12 V
9	+12 V

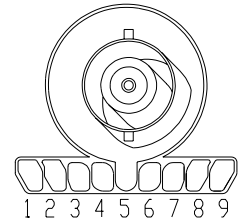

Any failure may be a problem with the probe power and control assembly, the AutoProbe flex cable W8, or the probe power and control cable W17.

## To Check the keyboard

Use this procedure only if you encounter key failures in the keyboard test procedure. If any knobs fail, replace the keyboard assembly.

- 1** Disconnect the power cord and remove the cover.
- 2** Remove the front panel assembly.  
See chapter 6 for instructions.
- 3** Remove the keyboard assembly and the cursor keyboard assembly from the front panel assembly. Partially re-assemble the front panel assembly, including the flat-panel display and lens, but omitting the keyboard and cursor keyboard. Re-attach the partial assembly to the chassis.  
Be sure to reconnect the display video cable and the backlight inverter cables. See chapter 6 for instructions on removing and disassembling the front panel.
- 4** Separate the elastomeric keypads from the cursor keyboard and keyboard assemblies.

---

### CAUTION

CONTAMINATION CAN CAUSE INTERMITTENT OPERATION!

Be careful not to contaminate the key side of the PC board or the keypads. Dust and fingerprints on these parts may cause intermittent key operation.

- 5** Set the cursor keyboard and keyboard assembly on an antistatic electrical insulated surface.
- 6** Connect the cursor keyboard cable to the keyboard assembly. Connect the keyboard cable to the oscilloscope interface board in the chassis.  
You may need to set the chassis on its side to allow proper routing of the cables without straining them.
- 7** Reconnect the power cable and apply power.
- 8** Enable the graphical interface, then start the keyboard test as described in the previous procedure.
- 9** Carefully short the PC board trace, with a paper clip or screwdriver, at each non-operating key (as determined by keyboard test), and look for an appropriate response on the display.
  - If the display responds as though a key were pressed, replace the elastomeric keypad.
  - If the display does not respond as though a key were pressed, replace the keyboard.
- 10** Re-assemble the oscilloscope.

## To check the LEDs

If you see a failure with the Auto or Trig'd LEDs, check the voltage at pin 6 of W12, with W12 disconnected from the keyboard. The voltage should be as follows:

- 0 V  $\pm$ 0.5 V when both LEDs are supposed to be off.
- 2.5 V  $\pm$ 0.5 V when Trig'd is supposed to be on and Auto is supposed to be off.
- 5.0 V  $\pm$ 0.5 V when both LEDs are supposed to be on.

If the voltages are not correct, the problem may be with keyboard cable W12, oscilloscope interface board A21, acquisition cable W3, or acquisition board A1. Try troubleshooting the acquisition system first to verify correct behavior before replacing any assemblies. If the voltages are correct but the LEDs do not light correctly, replace the keyboard assembly.

If you find a problem with the Armed LED, check pin 5 of W12 with the cable disconnected from the keyboard. The voltage should be as follows:

- 5.0 V  $\pm$ 0.5 V when Armed is supposed to be on.
- < 3.6 V  $\pm$ 0.5 V when Armed is supposed to be on.

Isolation is the same as for the Trig'd and Auto LEDs.

If you find any other failures, replace the keyboard assembly. If the front panel power indicator LED does not light, replace the cursor keyboard assembly.

## To check the motherboard, CPU, and RAM

This procedure verifies that the PC system board and the associated CPU and RAM are functioning. It assumes that the power supply, display board (when present), and an external monitor are functioning correctly.

- 1 Connect an external keyboard to the keyboard port.
- 2 Connect an external XGA monitor to the video output connector on the rear panel.
- 3 Hold down the Tab key on the external keyboard, then press the power button on the oscilloscope.
- 4 Verify that a message showing the Main Processor type, memory, CPU Brand, IDE Drives, etc. momentarily appears on the monitor. The message will only appear momentarily, then it will disappear.
- 5 If the message is displayed, you can assume that the PC system board, CPU, and RAM are functioning correctly.

If you need to run setup, press DEL. Otherwise, turn off the power and proceed with troubleshooting.

Figure 5-9

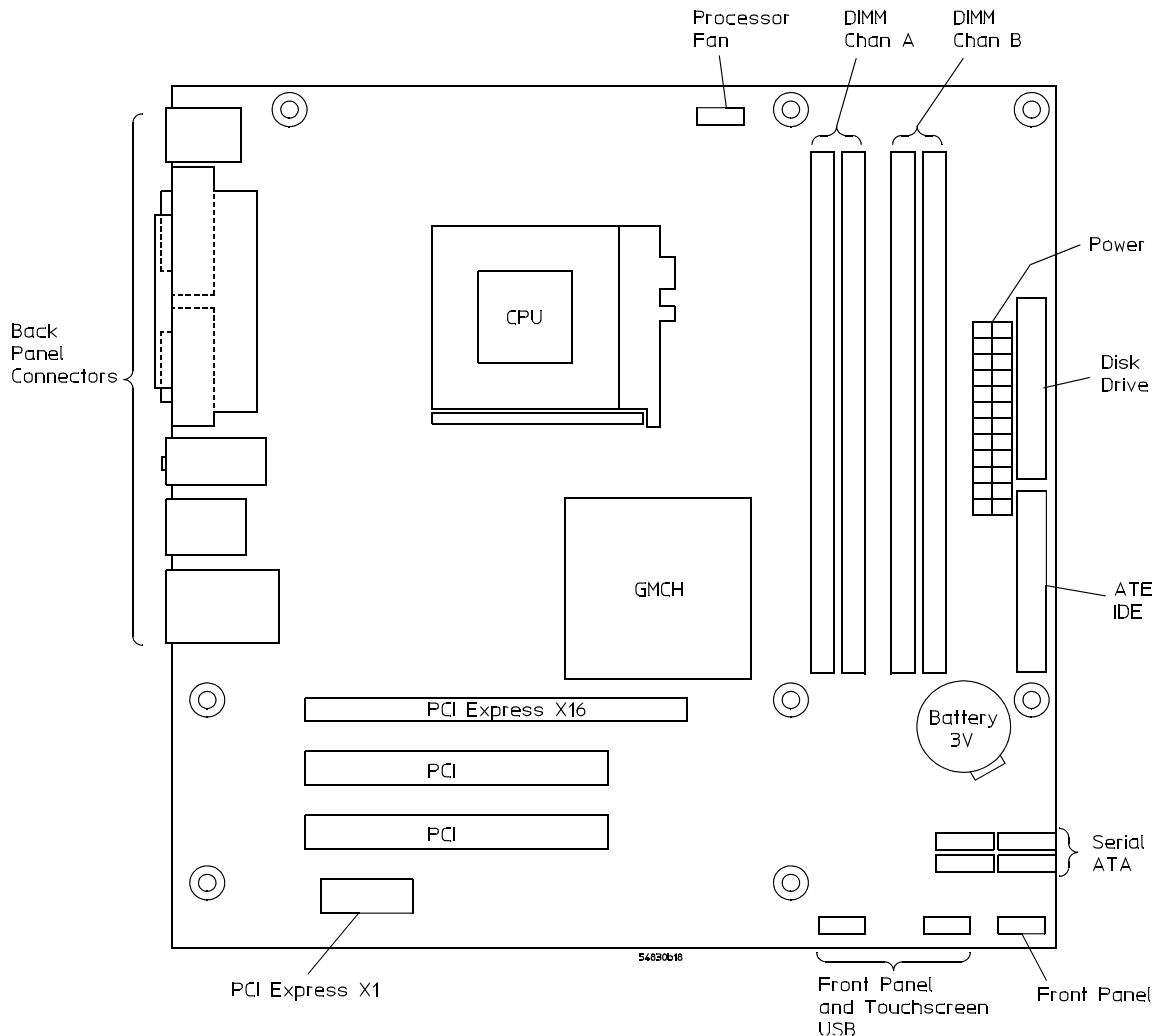

Figure 5-10: Intel D915GUX Motherboard:

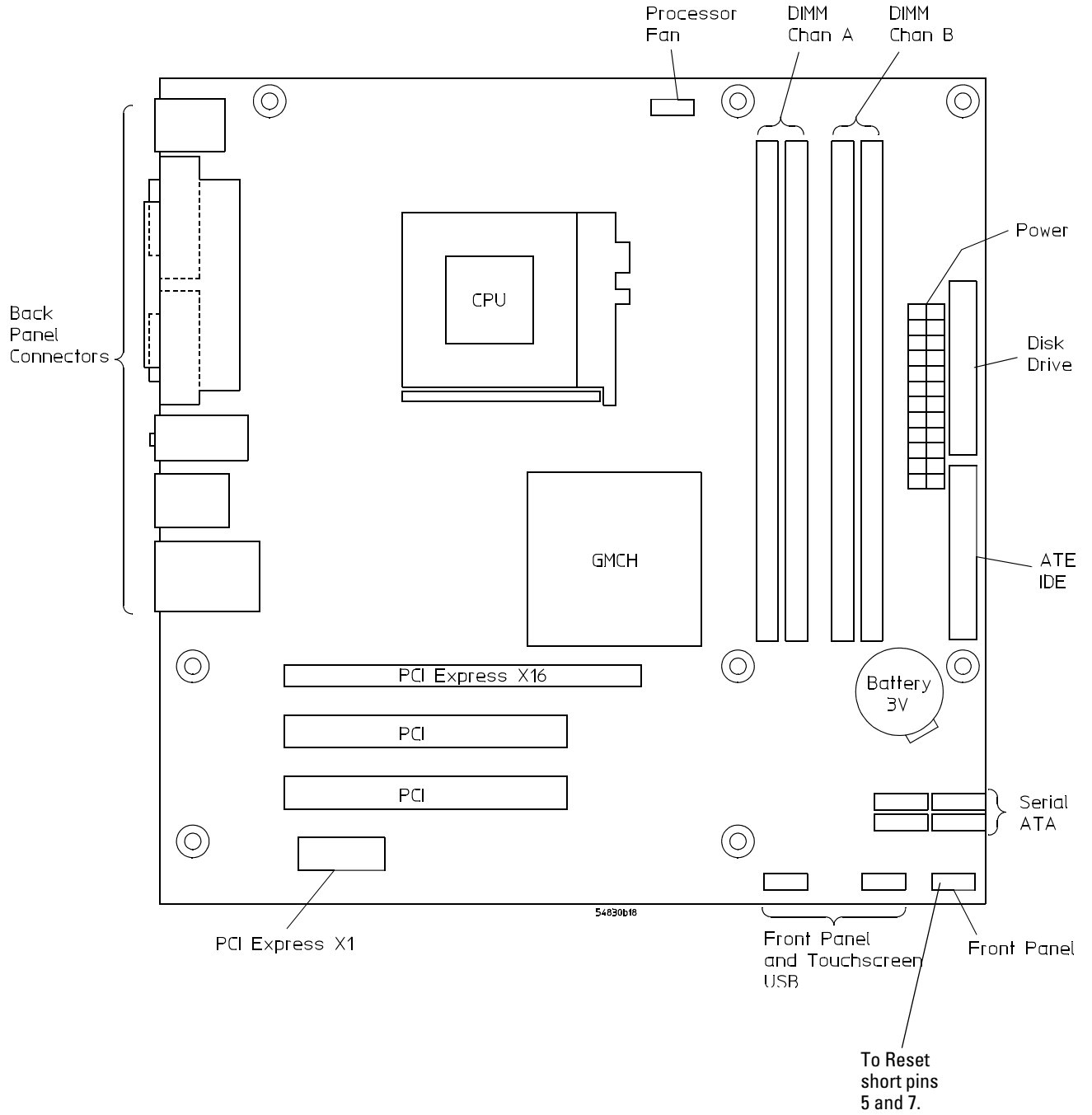
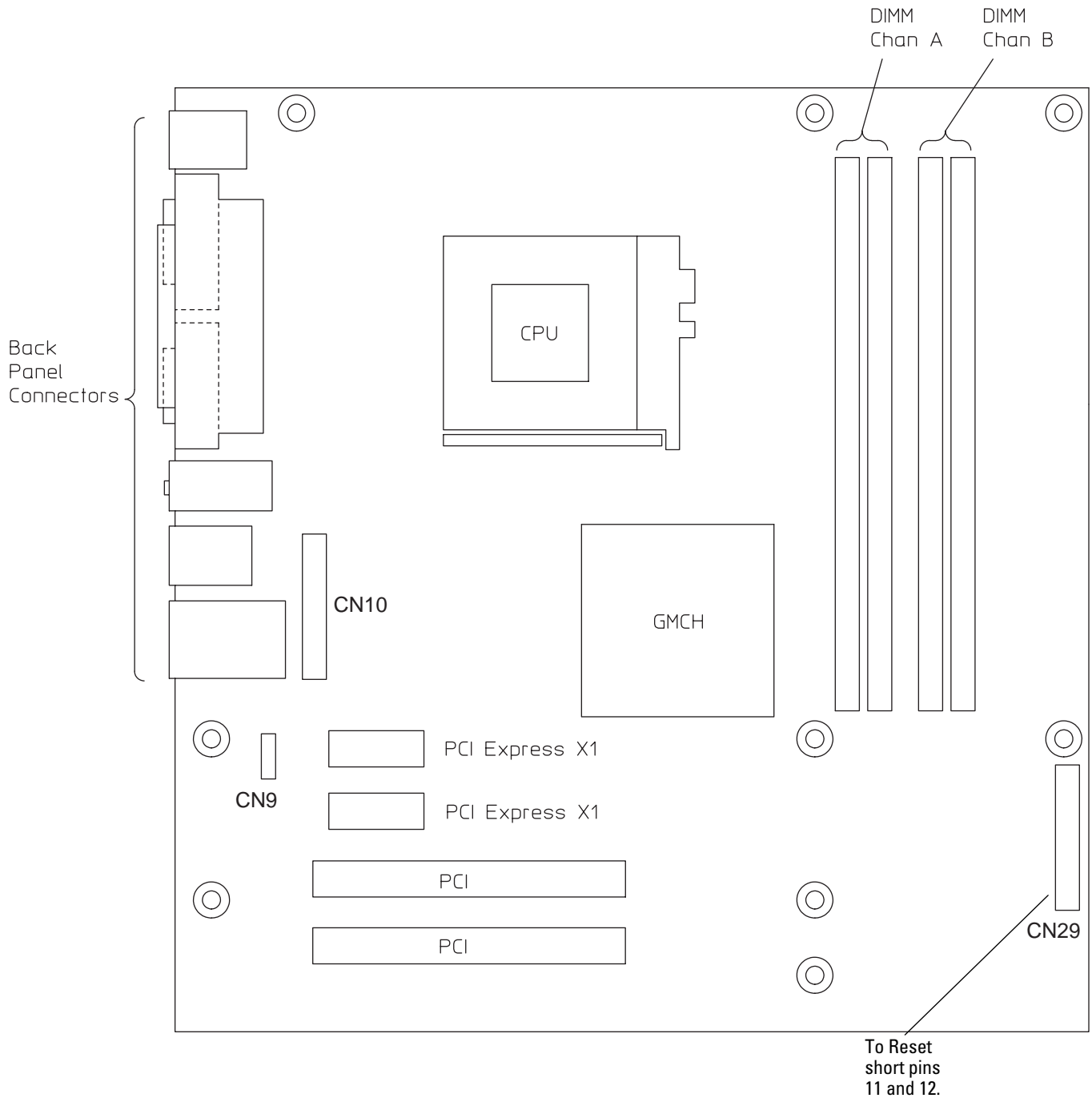

Figure 5-11 ADLINK M-880 Motherboard



## To setup the BIOS

If the BIOS settings become corrupt, the Infinium oscilloscope PC motherboard will not recognize the hard drive and the unit may not boot. The motherboard BIOS setup procedure is presented in the following pages.

### **Configure the Motherboard BIOS parameters.**

Use this procedure to set the motherboard BIOS.

- 1** Connect the power cable to the Infinium oscilloscope.
- 2** Connect the external keyboard to the rear panel.
- 3** Press the delete key when you see the following prompt on the bottom of the screen  
  
`Press TAB to Show POST screen, DEL to enter SETUP, F12 to select boot device.`  
  
Note: If you do not see the prompt, or the oscilloscope does not appear to be functioning, check the ribbon cable connectors. Otherwise, continue with the next step.
- 4** Go to **Load Optimized Defaults** (systems with the Intel motherboard) or go to **Load 8.4" LCD Defaults** (systems with the ADLINK motherboard) and press Enter key. Select **Y** to load the defaults, then press the Enter key.
- 5** Press F10 to save and exit the setup. Type "Y" to save changes.

## To troubleshoot the acquisition system

- 1 Select Self Test from the Utilities menu.
- 2 Select Start Self Test to run the test.

At the end of the self test the diagnostics box will show the results of each of the major group tests. If a group test fails, additional information will be shown with regards to the failure.

Figure 5-12

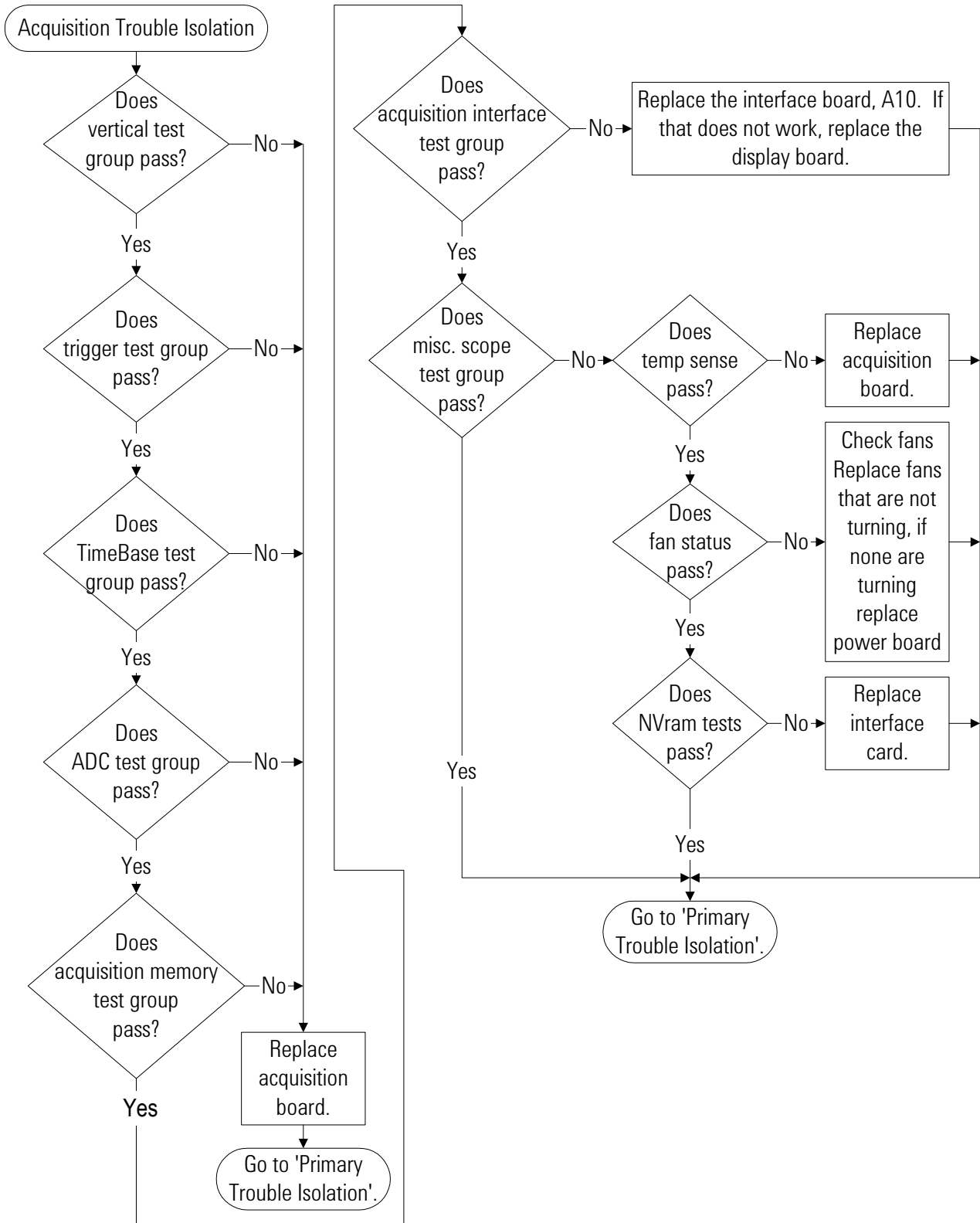

Acquisition Trouble Isolation

---

## Software Revisions

- Select About Infiniium... from the Help menu.

A dialog box appears showing the current version number for the oscilloscope software and built-in information system software. This information may be useful when contacting Agilent Technologies for further service information. See See Figure 5-13.

**Figure 5-13**

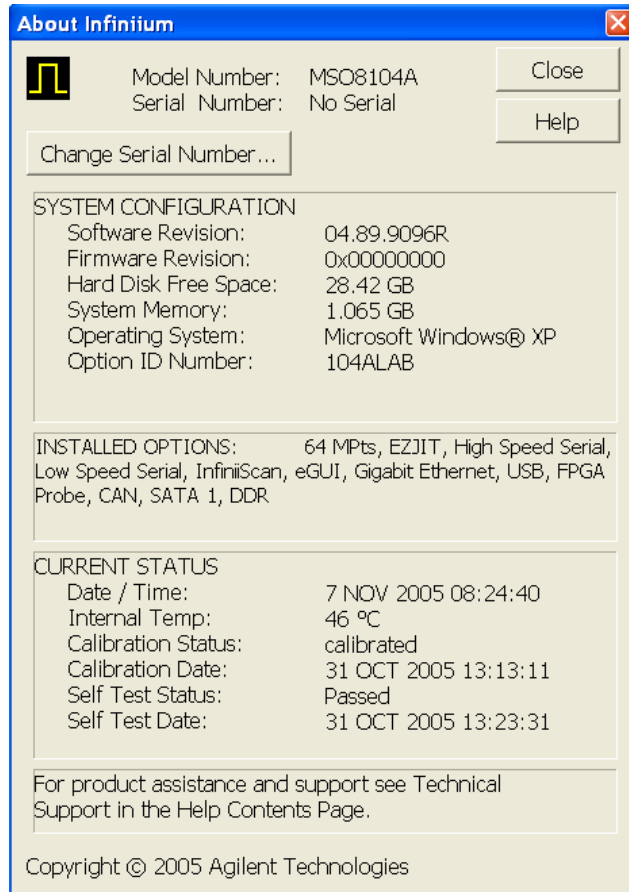

### About Infiniium... Information

ESD Precautions	96
Tools Required	96
To return the oscilloscope to Agilent Technologies for service	97
To remove and replace the top cover	98
To remove and replace the bottom sleeve	99
To disconnect and connect Mylar flex cables	101
To remove and replace the CD-ROM drive	102
To remove and replace the AutoProbe assembly	104
To remove and replace the internal digital input cable (MSO models only)	106
To remove and replace the backlight inverter board	107
To remove and replace the front panel assembly	108
To remove and replace the keyboard, touch screen, and flat-panel display assemblies	113
To remove and replace the acquisition board assembly	116
To remove and replace the PCI bridge board	117
To remove and replace the display board	119
To remove and replace the hard disk drive	120
To remove and replace the motherboard	122
To replace the Intel motherboard with the ADLINK motherboard	124
To remove and replace the power supply	131
To remove and replace the fan controller board	134
To remove and replace a fan	135
To remove and replace the probe power and control assembly	136

---

# Replacing Assemblies

Use the procedures in this chapter when removing and replacing assemblies and parts in the Agilent Technologies 8000 Series oscilloscope.

In general, the procedures that follow are placed in the order to be used to remove a particular assembly. The procedures listed first are for assemblies that must be removed first.

The graphics in this chapter are representative of the oscilloscope at the time of this printing. Your unit may look different.

## ESD Precautions

When using any of the procedures in this chapter, you must use proper ESD precautions to protect the oscilloscope components from ESD damage. Failure to follow proper ESD control procedures may cause immediate failure or latent damage. Latent damage may result in equipment failure after a period of time. As a minimum, you should place the oscilloscope on a properly grounded ESD mat and wear a properly grounded ESD wrist strap when working on the oscilloscope.

---

### CAUTION

**AVOID DAMAGE TO THE OSCILLOSCOPE!**

Failure to implement proper antistatic measures may result in damage to the oscilloscope.

## Tools Required

The following tools are required for these procedures.

- Torx drivers: T6, T8, T10, T15, T20
- Socket wrench: 5/8 inch
- Medium size (3/16-in) flat-blade screwdriver
- Nut Drivers: 3/16-in, 9/32-in, 5/16-in, 5/8-in
- Torque driver, 0.34 Nm (3 in-lb), 5 mm or 3/16-in hex drive
- Torque driver, 0.34 Nm (3 in-lb), Torx T6 drive

---

### CAUTION

**REMOVE POWER BEFORE REMOVING OR REPLACING ASSEMBLIES!**

Do not remove or replace any circuit board assemblies in this oscilloscope while power is applied. The assemblies contain components which may be damaged if the assembly is removed or replaced while power is connected to the oscilloscope.

---

### WARNING

**SHOCK HAZARD!**

To avoid electrical shock, adhere closely to the following procedures. Also, after disconnecting the power cable, wait at least three minutes for the capacitors on the power supply to discharge before servicing this oscilloscope. Hazardous voltages exist on the inverter for the display monitor while power is applied.

## To return the oscilloscope to Agilent Technologies for service

Before shipping the oscilloscope to Agilent Technologies, contact your nearest Agilent Technologies oscilloscope Support Center (or Agilent Technologies Service Center if outside the United States) for additional details. You can also visit [www.agilent.com](http://www.agilent.com) and follow the links for returning Test & Measurement equipment.

**1 Write the following information on a tag and attach it to the oscilloscope.**

- Name and address of owner
- Oscilloscope model number
- Oscilloscope serial number
- Description of the failure indications or service required.

**2 Remove all accessories from the oscilloscope.**

Accessories include all cables. Do not include accessories unless they are associated with the failure symptoms.

**3 Protect the oscilloscope by wrapping it in plastic or heavy paper.**

**4 Pack the oscilloscope in foam or other shock absorbing material and place it in a strong shipping container.**

You can use the original shipping materials or order materials from an Agilent Technologies Sales Office. If neither are available, place 8 to 10 cm (3 to 4 inches) of shock-absorbing material around the oscilloscope and place it in a box that does not allow movement during shipping.

**5 Seal the shipping container securely.**

**6 Mark the shipping container as FRAGILE.**

In any correspondence, refer to oscilloscope by model number and full serial number.

## To remove and replace the top cover

Use this procedure to remove and replace the top cover. The graphics in this chapter are representative of the oscilloscope at the time of this printing. Your unit may look different.

- 1 Disconnect the power cable.
- 2 Disconnect all oscilloscope probes and BNC input cables from the front panel.
- 3 Disconnect any other cables, such as mouse, keyboard, printer, or GPIB cables.
- 4 Remove the two Torx T20 screws securing the side handle.
- 5 Remove the four Torx T20 screws that secure the rear feet (two in each foot).
- 6 Remove the four Torx T20 screws that secure the top sleeve and the bottom sleeve to the chassis.
- 7 Place the unit so the bottom is facing up.
- 8 Remove the eight Torx T10 screws that secure the bottom sleeve to the chassis.
- 9 Set the unit on its bottom. Carefully slide the top cover off of the frame by pulling the front panel and the cover away from each other.
- 10 To replace the top cover, reverse the above procedure.

### CAUTION

PROPERLY TIGHTEN HANDLE AND SCREWS!  
Torque the side handle and rear feet screws to 2 Nm (18 in-lb).

Figure 6-1

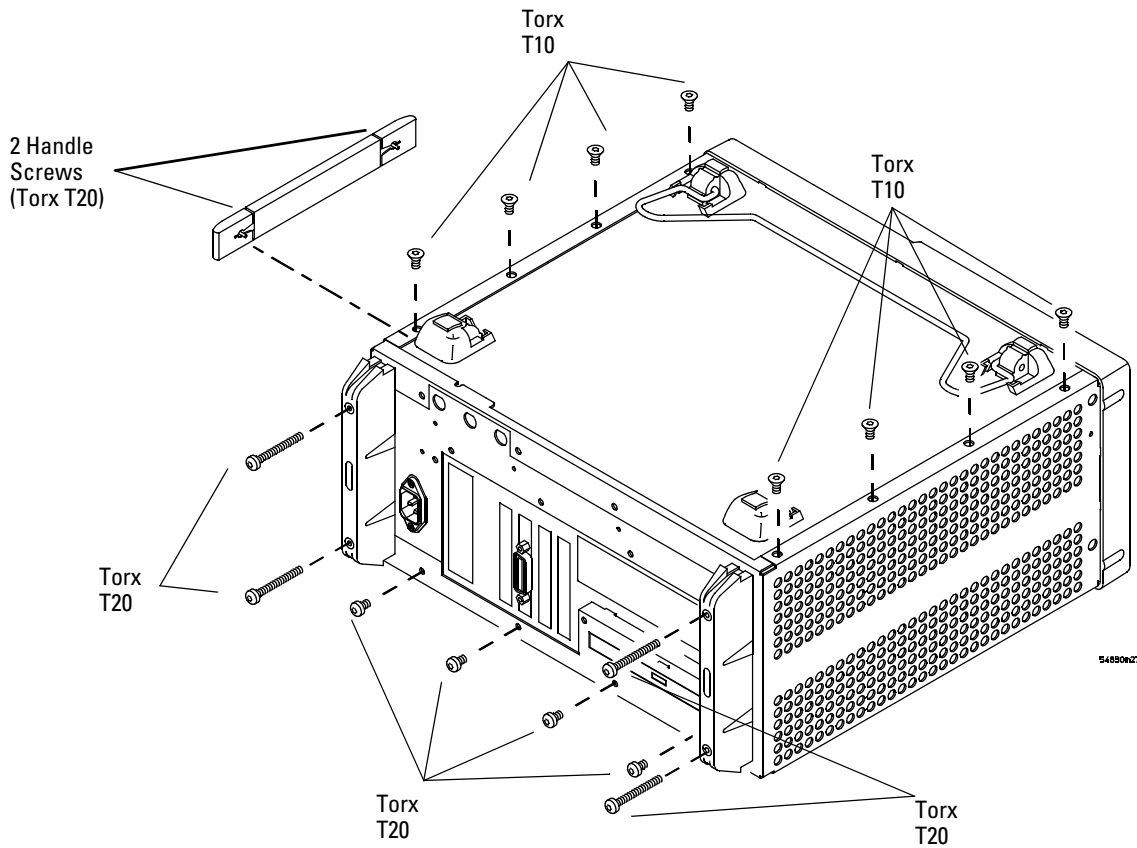

Top cover fasteners

---

## To remove and replace the bottom sleeve

Use this procedure to remove the bottom sleeve. The graphics in this chapter are representative of the oscilloscope at the time of this printing. Your unit may look different.

- 1 Disconnect the power cable.
- 2 Disconnect all oscilloscope probes and BNC input cables from the front panel.
- 3 Disconnect any other cables, such as mouse, keyboard, printer, or GPIB cables.
- 4 Place the unit so the bottom is facing up.
- 5 Remove the four Torx T20 screws that secure the rear feet (two in each foot).
- 6 Remove the eight Torx T10 screws that secure the bottom to the chassis.
- 7 Remove the four Torx T20 screws that secure the back panel to the chassis.

Figure 6-2

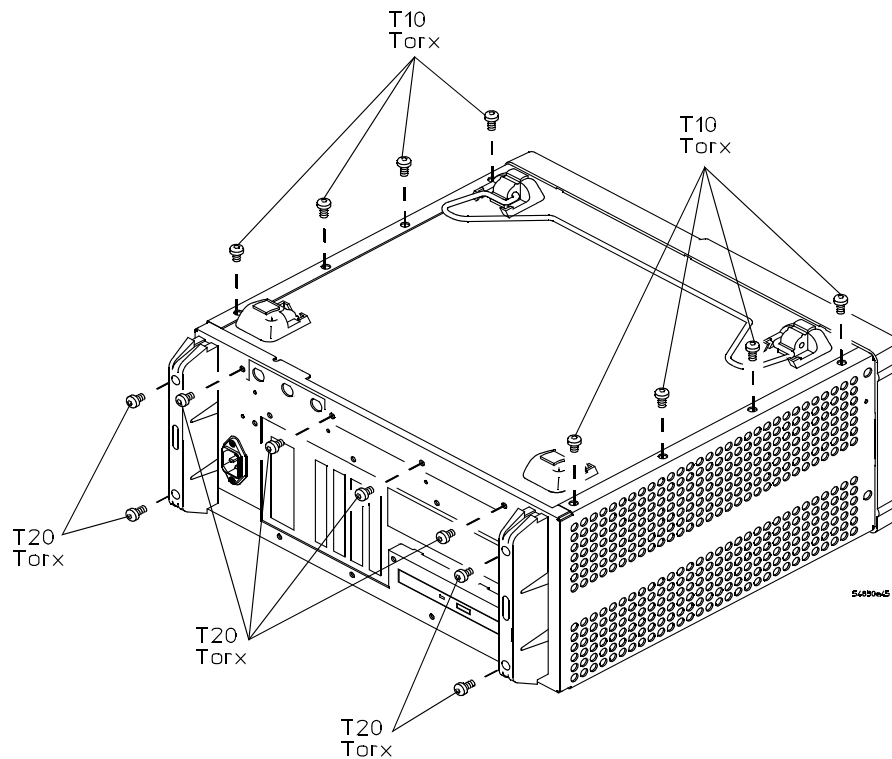

Bottom sleeve fasteners

- 8 Remove the two T20 handle screws to remove the handle.
- 9 Gently lift the bottom sleeve up and out. Be careful to not catch the feet on the chassis.

Figure 6-3

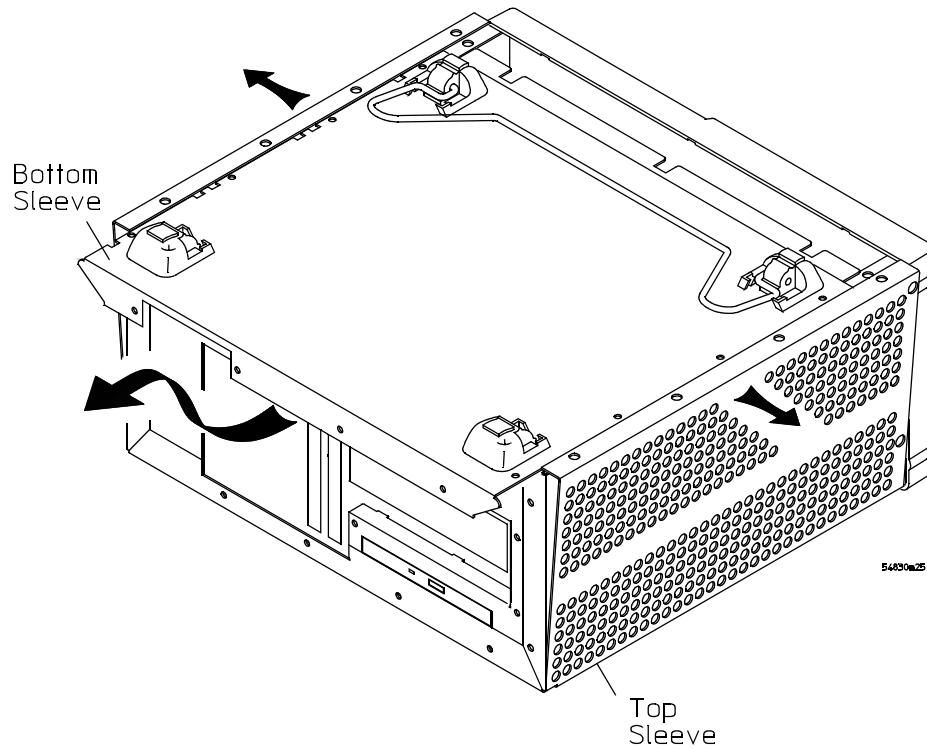

**Removing bottom sleeve**

- 10 To replace the bottom sleeve, reverse the above procedure.  
Be sure to keep ribbon cables out of the way when replacing the cover, particularly the flex cable and connector for the AutoProbe assembly at the bottom front of the oscilloscope.

---

## To disconnect and connect Mylar flex cables

Use this procedure when you are instructed to disconnect or connect a Mylar flex cable. Such cables and their connectors are fragile; mishandling may damage the cable or connector.

### To disconnect the cable

- 1 Pry up the retainer slightly at each end of the connector using a small flat-blade screwdriver. Do not force the retainer; it should remain attached to the body of the socket.
- 2 Gently pull the flex cable out of the connector.

Figure 6-4

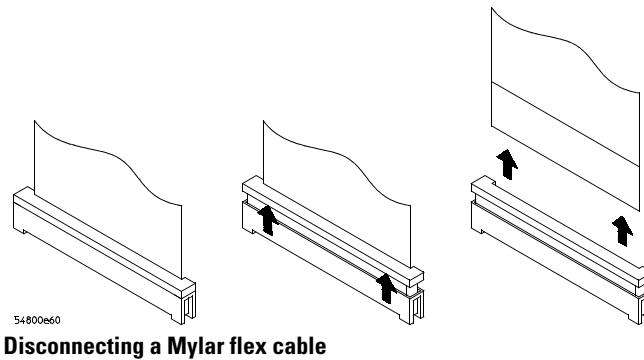

### To reconnect the cable

- 1 Ensure that the cable retainer is up, then insert the ribbon cable into the socket, making sure to observe polarity of the cable with respect to the connector.
- 2 Push the ends of the retainer down onto the connector body, using a small flat-blade screwdriver. The retainer should be flush with the connector body when you are finished.

Figure 6-5

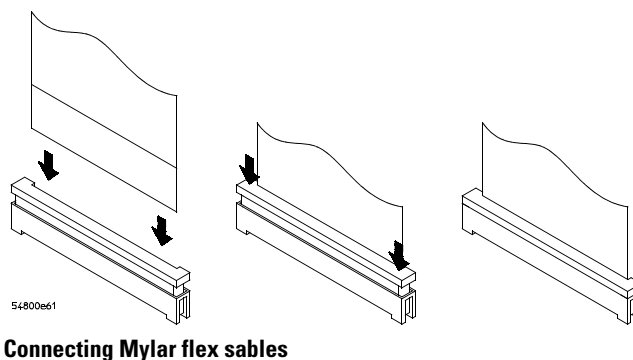

---

## To remove and replace the CD-ROM drive

Use this procedure to remove and replace the CD-ROM drive on units so equipped (newer units will not have internal CD-ROM drives; an optional external DVD drive will be available). When necessary, refer to other removal procedures. The graphics in this chapter are representative of the oscilloscope at the time of this printing. Your unit may look different.

- 1 Disconnect the power cable from the instrument and remove the top sleeve.
- 2 Remove the following cables:
  - SATA Cable
  - CD-ROM Power cable
- 3 Using a Torx T10 driver, remove the three CD-ROM support bracket screws holding the CD-ROM drive in place.  
When re-assembling, torque the three Torx T10 screws to 5 in-lb.
- 4 Using a T20 driver remove the back panel screw holding the CD-ROM drive in place.  
When re-assembling, torque the Torx T20 screw to 18 in-lb.
- 5 Move the CD-ROM drive back towards the front frame, then lift and pull to remove.

Figure 6-6

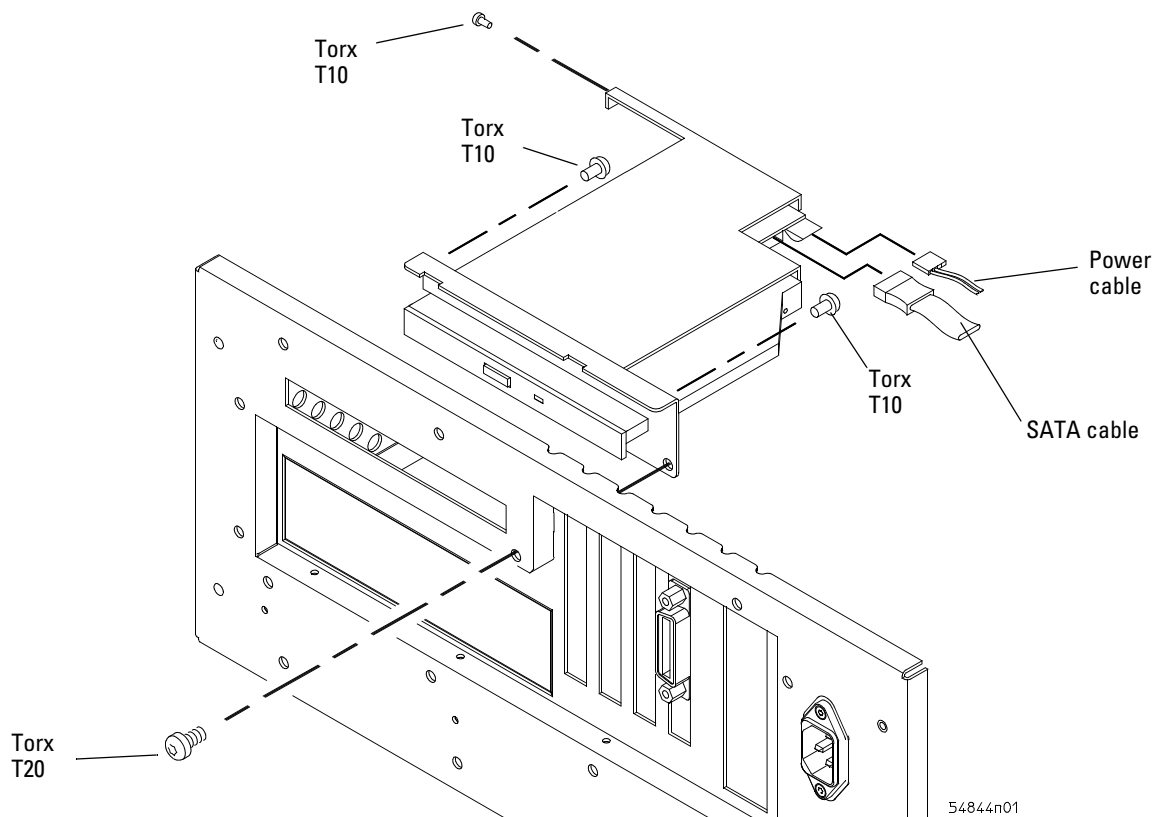

### Removing the CD-ROM assembly

- 6 Using a Torx T6 driver, remove the three screws securing the CD-ROM to the support bracket.  
When re-assembling, torque the three Torx T6 screws to 1.5 in-lb.
- 7 Using a Torx T10 driver, remove the two screws securing the CD-ROM adapter board to the support bracket.  
When re-assembling, torque the two Torx T6 screws to 1.5 in-lb.

Figure 6-7

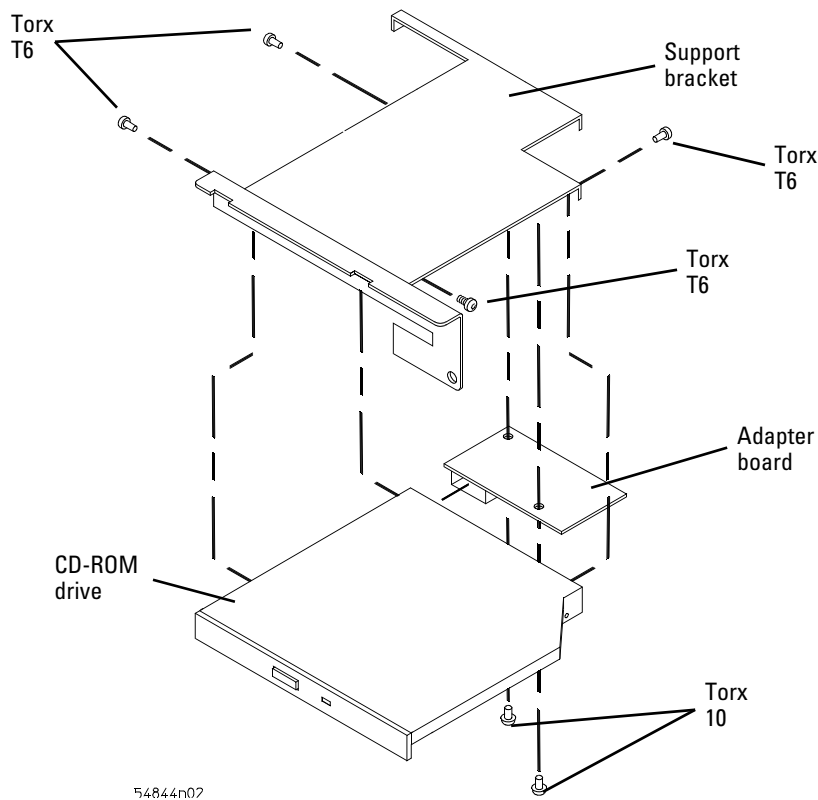

54844n07  
Removing the support bracket and adapter board

- 8 To replace the CD-ROM drive, reverse the above procedure.

---

## To remove and replace the AutoProbe assembly

Use this procedure to remove and replace the AutoProbe assembly. When necessary, refer to other removal procedures. The graphics in this chapter are representative of the oscilloscope at the time of this printing. Your unit may look different.

- 1 Disconnect the power cable and remove the top and bottom sleeves.
- 2 Remove the AutoProbe connector assembly, the subpanel, and the probe connector assembly that fits around the front-panel BNC connectors, by doing the following:
  - a Disconnect the mylar ribbon cable W8 from the Probe Power and Control Board, A9.  
See “To disconnect and connect Mylar flex cables” on page 101.

Figure 6-8

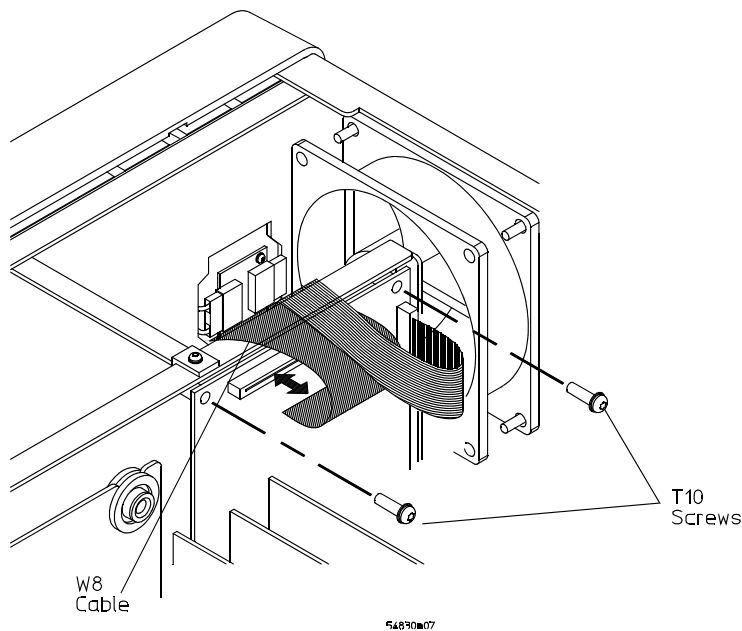

### Disconnecting W8

- b Locate the access hole in the front-panel assembly below and almost between channel two and channel three attenuators. See Figure 6-9.
- c Use a small screwdriver or other slender pointed object inserted through the access hole to push the AutoProbe assembly faceplate out.

Figure 6-9

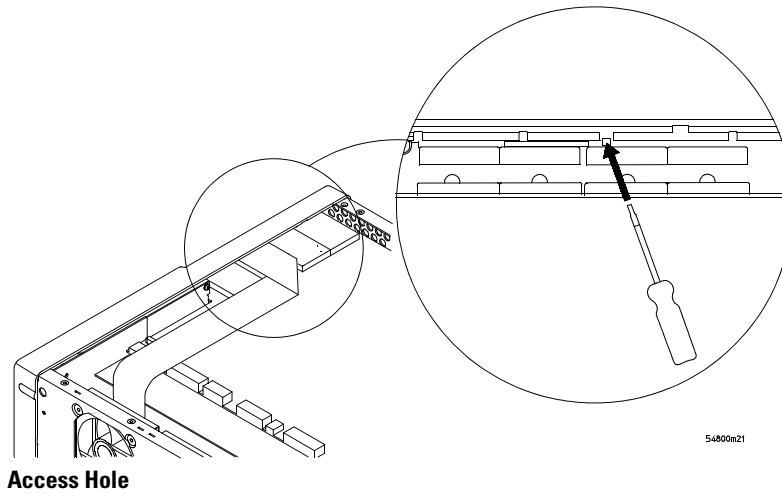

---

**CAUTION**

---

AVOID DAMAGE TO THE RIBBON CABLE AND FACEPLATE!  
Do not pry around the edge of the assembly. Doing so may damage the ribbon cable or faceplate.

- d Finish removing the AutoProbe assembly by feeding the mylar ribbon cable through the front panel slot.

Figure 6-10

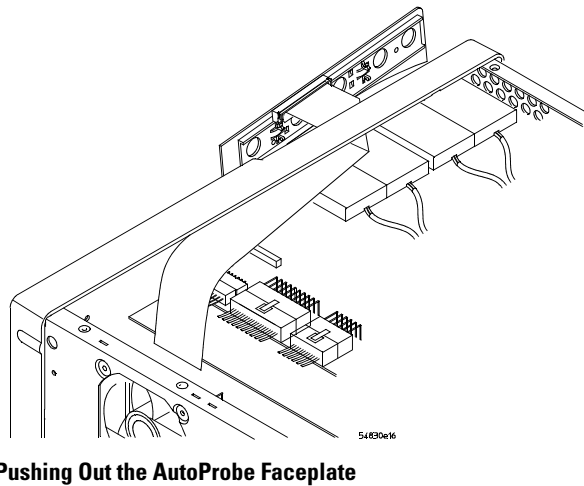

- 3 To replace the AutoProbe assembly, reverse the above procedure.

---

## To remove and replace the internal digital input cable (MSO models only)

Use this procedure to remove and replace the internal digital cable. When necessary, refer to other removal procedures. The graphics in this chapter are representative of the oscilloscope at the time of this printing. Your unit may look different.

- 1 Disconnect the power cable and remove the bottom sleeve.
- 2 Remove the AutoProbe board assembly from the front frame (see page 104).
- 3 Use a small screwdriver to remove the spring clip from the internal digital cable connector then disconnect the cable from the acquisition board.
- 4 Clip the tie wraps holding the digital cable and shield to the side of the chassis.
- 5 Using a Torx T10 driver remove the screw holding the internal digital cable to the front panel.

**Figure 6-11**

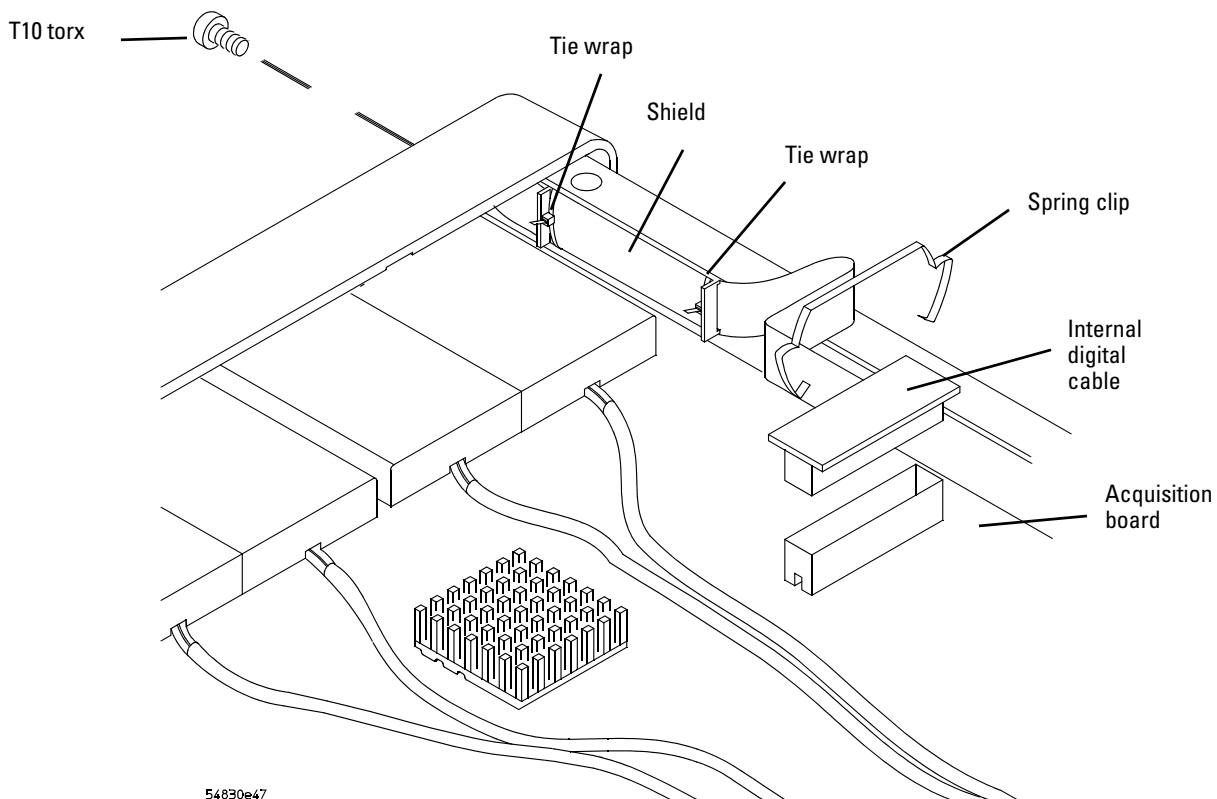

54830e47

### Removing the internal digital cable

- 6 Pull the internal digital cable out through the rear of the front panel.
- 7 To replace the internal digital cable, reverse the above procedure.

## To remove and replace the backlight inverter board

Use this procedure to remove and replace the backlight inverter board. When necessary, refer to other removal procedures. The graphics in this chapter are representative of the oscilloscope at the time of this printing. Your unit may look different.

### WARNING

#### SHOCK HAZARD!

The backlight inverter assembly, which is mounted at the front corner of the oscilloscope near the flat-panel display, operates at high voltages from 300-1 kV ac<sub>rms</sub>. DO NOT handle this assembly while it is in operation.

- 1 Disconnect the power cable and remove the top and bottom covers.
- 2 Disconnect the two backlight cables from the top of the backlight inverter board.
- 3 Disconnect the backlight primary cable from the bottom of the backlight inverter board.
- 4 Using a long Torx T10 driver, remove the two Torx T10 screws that secure the backlight inverter board to the chassis.
- 5 Lift the backlight inverter board out through the top of the chassis.
- 6 To replace the backlight inverter board, reverse this procedure.

Figure 6-12

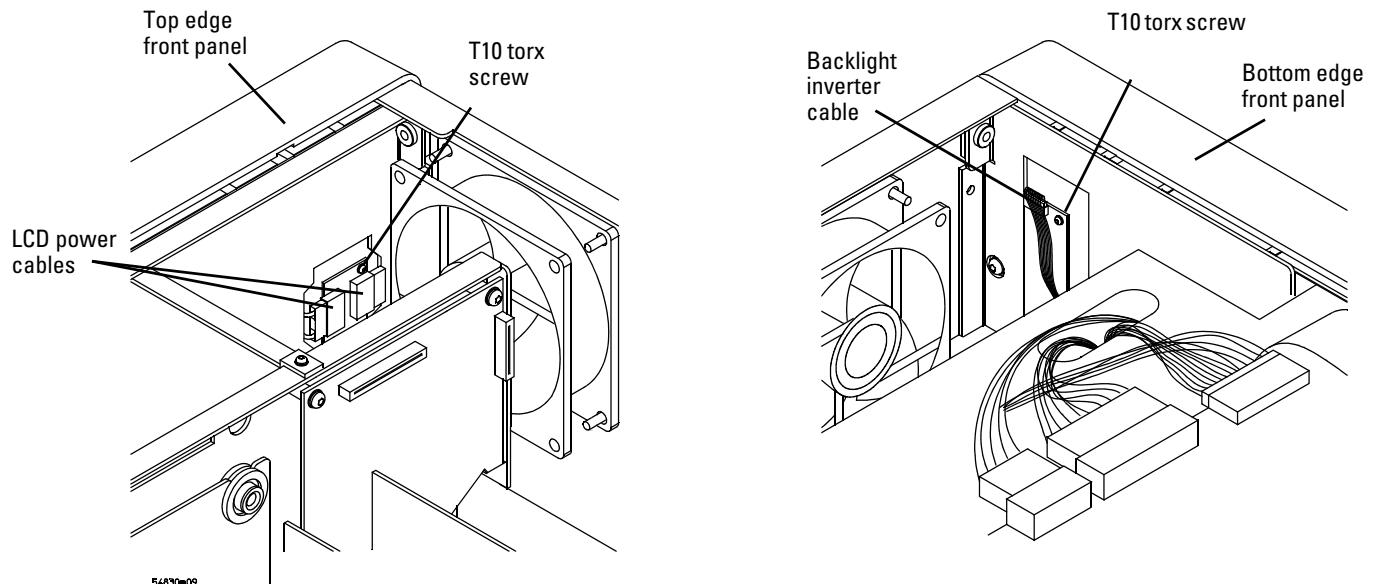

Removing the backlight inverter board

---

## To remove and replace the front panel assembly

Use this procedure to remove and replace the front panel assembly. When necessary, refer to other removal procedures. The graphics in this chapter are representative of the oscilloscope at the time of this printing. Your unit may look different.

- 1 Disconnect the power cable and remove top and bottom covers.
- 2 Remove the AutoProbe assembly and Mylar flex cable (see page 104).
- 3 Remove the internal digital cable if you have an MSO model oscilloscope (see page 106).
- 4 Use a 9/16 inch nut-driver to remove the hex nuts that secure the BNC connectors to the front panel.

**Figure 6-13**

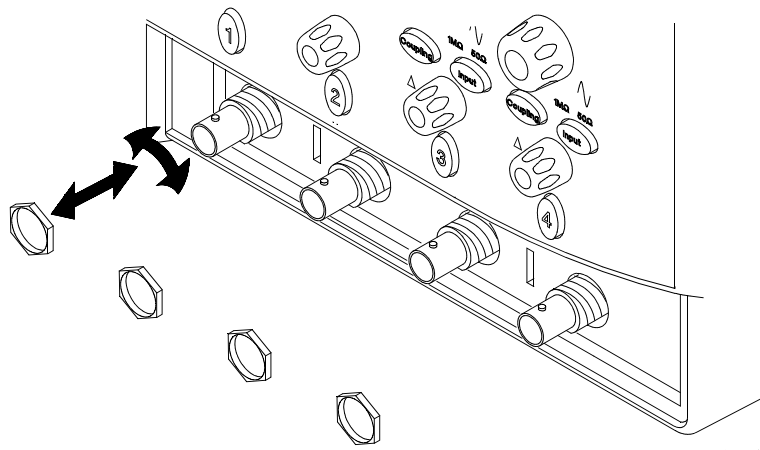

**Removing the BNC nuts**

- 5 Disconnect the backlight primary cable from the inverter board.
- 6 Disconnect the cal cable from J14 on the acquisition board.

Figure 6-14

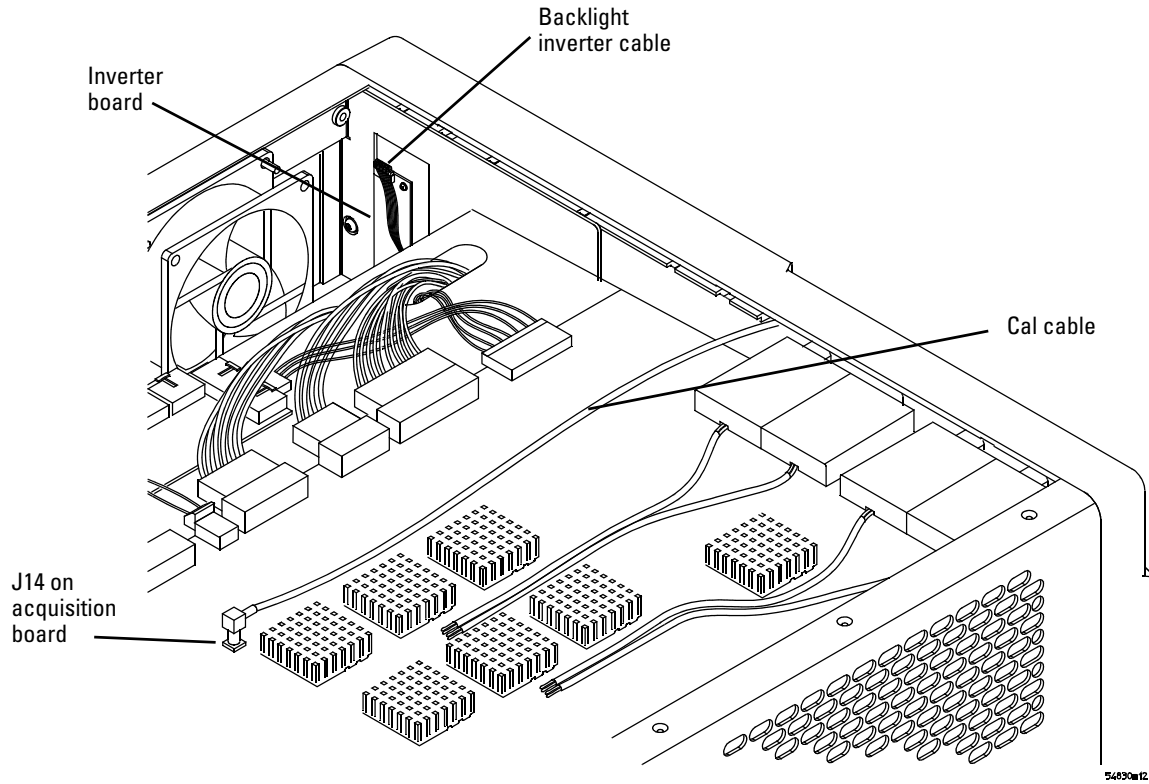

**Removing backlight primary cable and cal cable**

- 7 Disconnect the flat-panel display driver cable, and keyboard ribbon cable.
- 8 Disconnect the 2 USB cables from the motherboard.

**Figure 6-15**

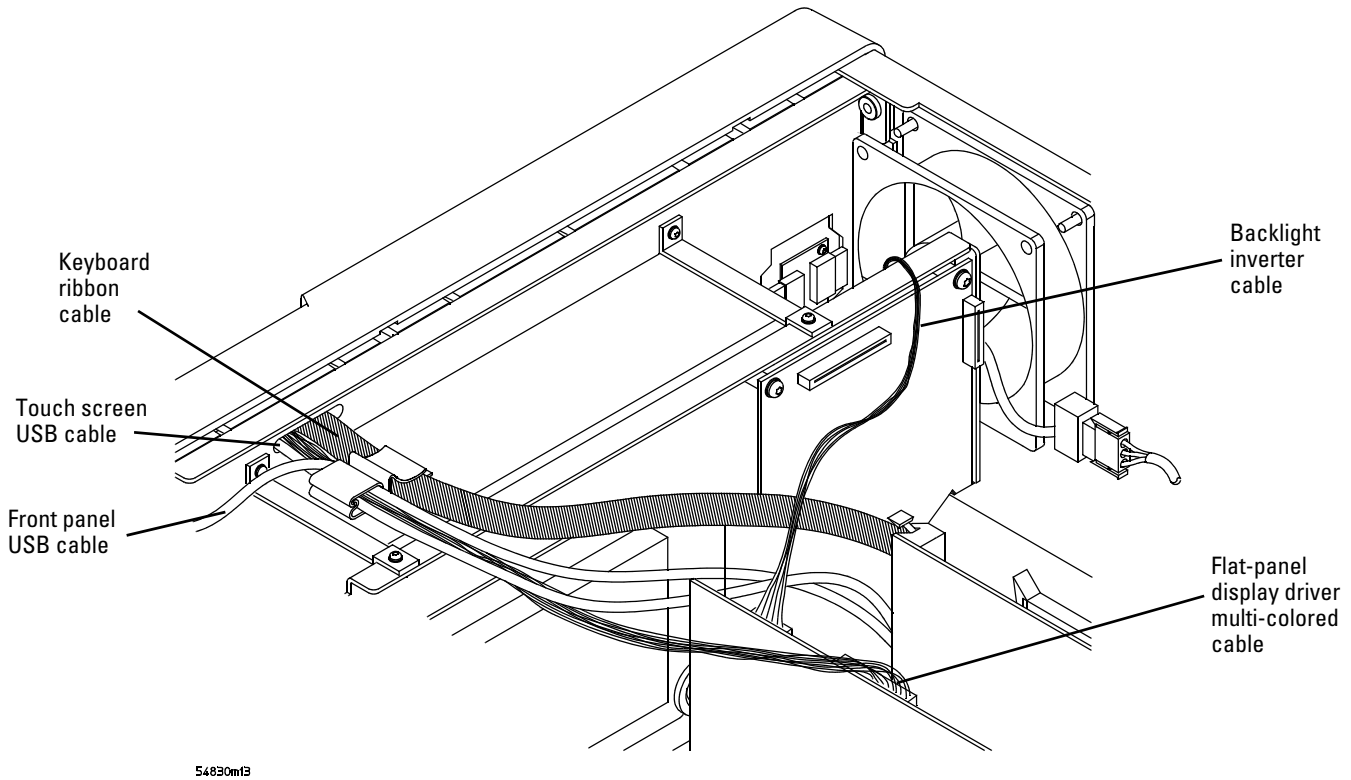

**Disconnecting the display driver cable, keyboard cable, and USB cables**

- 9 Remove the four Torx T15 screws that secure the chassis sides to the front panel assembly.
- 10 Remove the two Torx T15 screws that secure the chassis front to the front panel assembly.

Figure 6-16

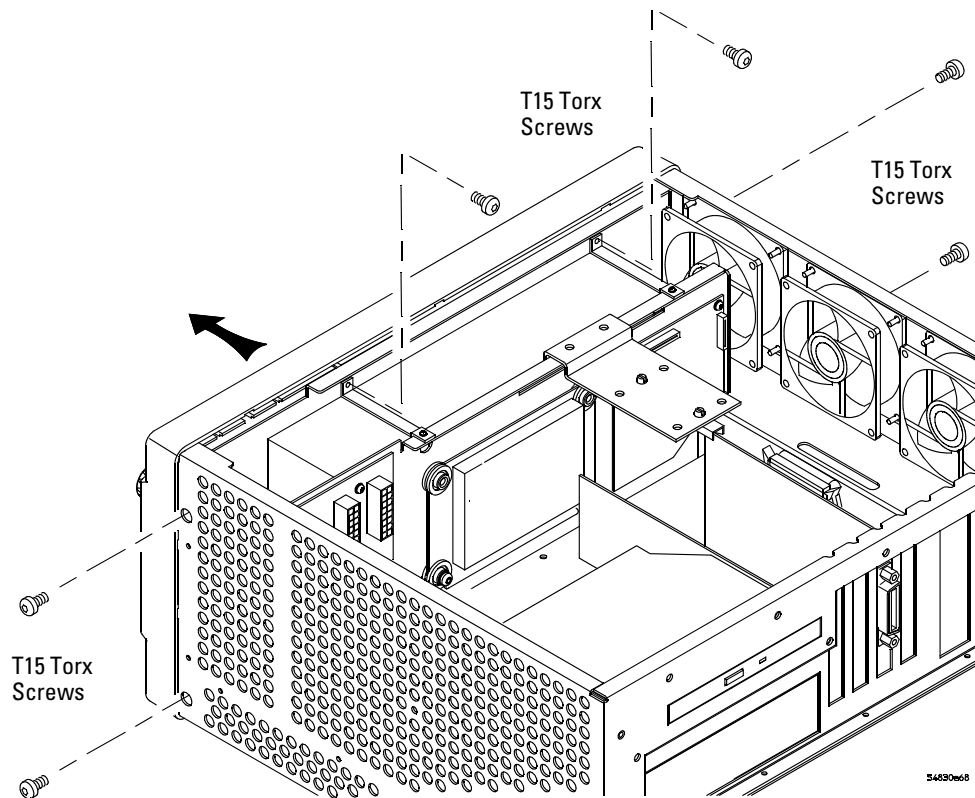

**Front panel side screws**

- 11 Pull the front panel assembly away from the chassis, being careful to feed the keyboard ribbon cable and display driver cable out through the slot in the front of the chassis and not to damage the backlight inverter board.
- 12 To replace the front panel assembly, reverse the above procedure.  
When reconnecting the USB cables align pin 1 (red wire) with the arrow on the motherboard as shown in See Figure 6-17.  
Be sure to torque the hex nuts for the BNC connectors and the T15 torx screws to 2 Nm (18 in-lb).

Figure 6-17

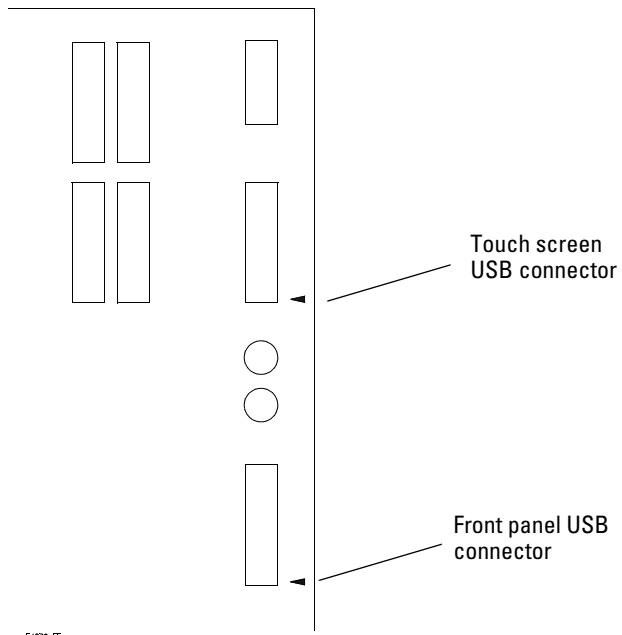

Connecting the USB cables to the motherboard

## To remove and replace the keyboard, touch screen, and flat-panel display assemblies

Use this procedure to disassemble and reassemble the front panel assembly, including the keyboard and flat-panel display. When necessary, refer to other removal procedures. The graphics in this chapter are representative of the oscilloscope at the time of this printing. Your unit may look different.

- 1 Disconnect the power cable and remove the top and bottom cover.
- 2 Remove the front panel assembly from the chassis (see page 108).
- 3 Remove the ten Torx T10 screws that secure the front panel cover plate to the front casting.

Figure 6-18

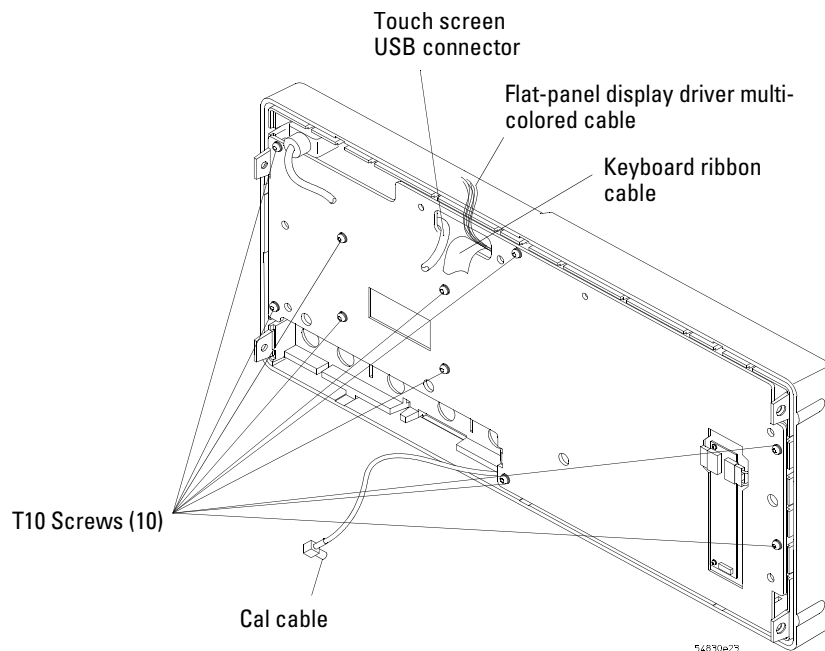

### Front panel cover plate screws

- 4 Carefully feed the front-panel keyboard ribbon cable through the cable access hole while separating the front panel cover plate from the front casting.

The display driver cable and touch screen USB cable remain attached to the cover plate.

#### **Keep Long Screws Separate for Re-assembly**

The four screws that fasten the keyboard to the front panel plate are longer than those around the perimeter of the plate. Keep them separate for re-assembly.

To remove and replace the keyboard, touch screen, and flat-panel display assemblies

- 5 To remove the main keyboard assembly, disconnect the cursor keyboard interconnect cable, pull off the knobs, and lift out the keyboard.

Figure 6-19

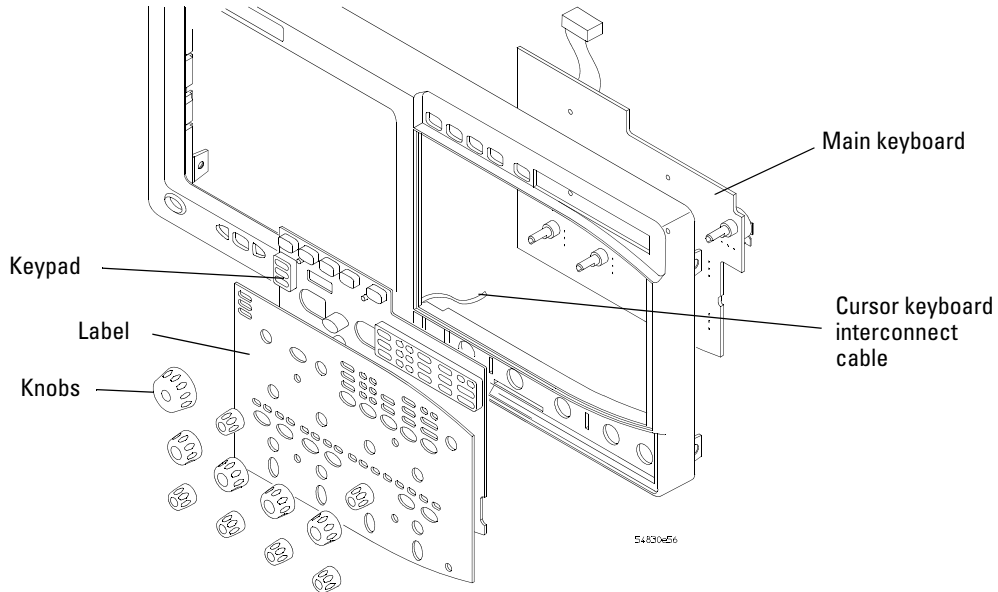

Removing the keyboard

- 6 To remove the touch screen assembly from the front-panel cover plate, remove the six T8 Torx fasteners.
- 7 To remove the flat-panel display assembly, remove the backlight inverter board (see page 107), then remove the four T8 Torx fasteners.

Figure 6-20

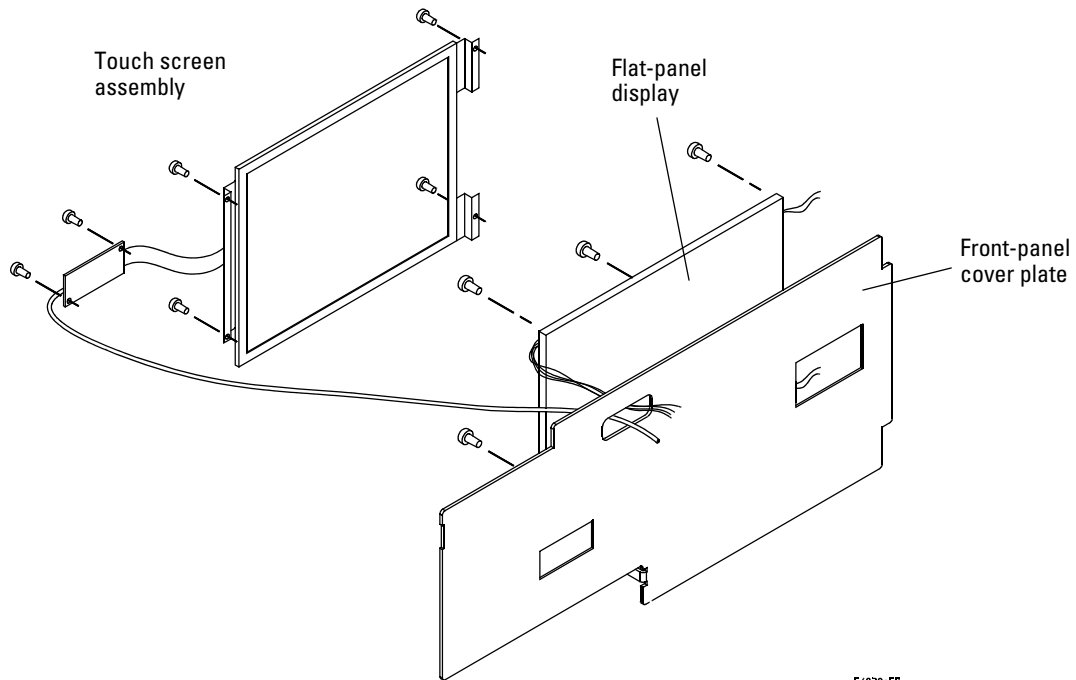

Removing the touch screen and flat-panel display

- 8 To remove the cursor keyboard, remove the two Torx T10 screws that secure the cursor keyboard bracket then lift the cursor keyboard directly out of the front casting.

Figure 6-21

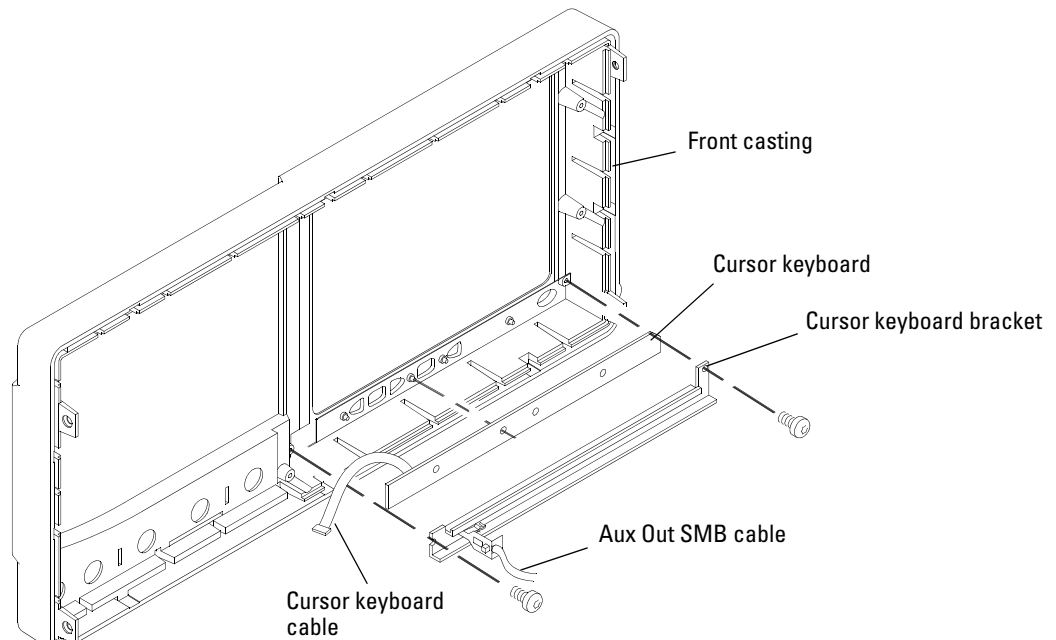

Removing the cursor keyboard

- 9 To reassemble the front panel assembly, reverse the above procedure. The cursor keyboard has holes that fit over locating pins in the front panel casting.

---

**CAUTION**

---

PREVENT GLASS BREAKAGE!

Use care when handling the touch screen and the flat-panel display to prevent glass breakage.

Inspect the inside surfaces of the touch screen and the flat-panel display closely for dust, smudges, and fingerprints. Viewing these with line-of-sight 45 degrees to the surface is the best method for seeing subtle flaws. Clean the surfaces of the touch screen with glass cleaner and lint-free lens paper before re-assembly. Clean the front of the FPD monitor by applying the glass cleaner to the lint-free lens paper or soft lens cloth. Do not apply glass cleaner directly to the FPD monitor.

## To remove and replace the acquisition board assembly

Use this procedure to remove and replace the acquisition assembly. When necessary, refer to other removal procedures. The graphics in this chapter are representative of the oscilloscope at the time of this printing. Your unit may look different.

- 1 Disconnect the power cable and remove the bottom cover.
- 2 Remove the AutoProbe assembly (see page 104).
- 3 Remove the hex nuts that secure the BNC connectors to the front panel.  
Use a 9/16" nut-driver to remove the hex nuts. See page 108.
- 4 Disconnect the three or four SMB cables from J13, J14, J15, and J16 from the acquisition board assembly.
- 5 Disconnect the following cables from the inside edge of the Acquisition assembly:
  - Power supply sense cable
  - Probe control cable
  - Power harness cable
  - Line sync cable
  - Acquisition cable
  - Internal digital cable (MSO model oscilloscopes only)These cables are attached to J5, J150, J6, J7, J9, J10, and J18 connectors. The J18 connector is near the CH4 attenuator.
- 6 Remove the 13 Torx T10 screws that secure the acquisition board to the chassis, then lift the board back from the front panel until the BNC connectors clear the panel. Lift the board away from the chassis.

Figure 6-22

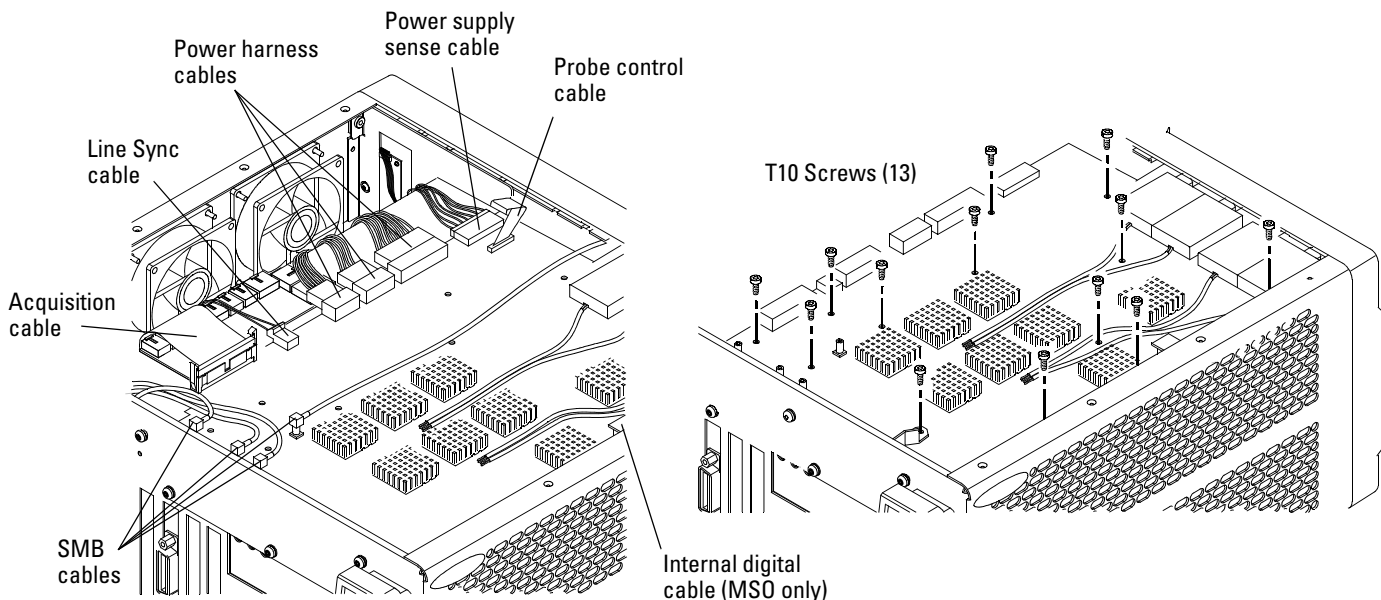

Removing the acquisition assembly

- 7 To re-install the acquisition board assembly, reverse the above procedure. Be sure to observe correct polarity for all cables and torque the BNC hex nuts to 2 Nm (18 in-lb).

---

## To remove and replace the PCI bridge board

Use this procedure to remove and replace the PCI bridge board. When necessary, refer to other removal procedures. The graphics in this chapter are representative of the oscilloscope at the time of this printing. Your unit may look different.

- 1 Disconnect the power cable and remove the top cover.
- 2 Remove the keyboard cable and the acquisition board cable from the PCI bridge board.
- 3 Remove the two Torx T10 screws that secure the PCI bracket assembly to the chassis.

**Figure 6-23**

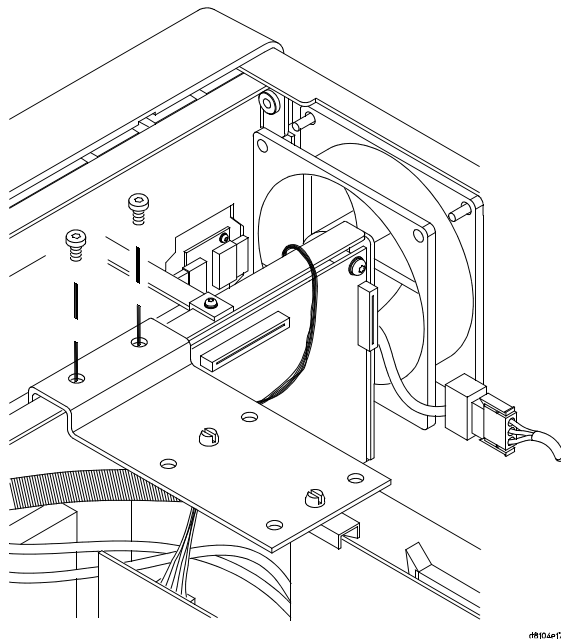

**To remove and replace the PCI bridge board**

- 4 Remove the Torx T10 screw that secures the PCI bridge board to the rear of the chassis.
- 5 Pull the board up to disengage it from the motherboard, then lift it up and out of the chassis.
- 6 To replace the board, reverse the removal procedure.

**Figure 6-24**

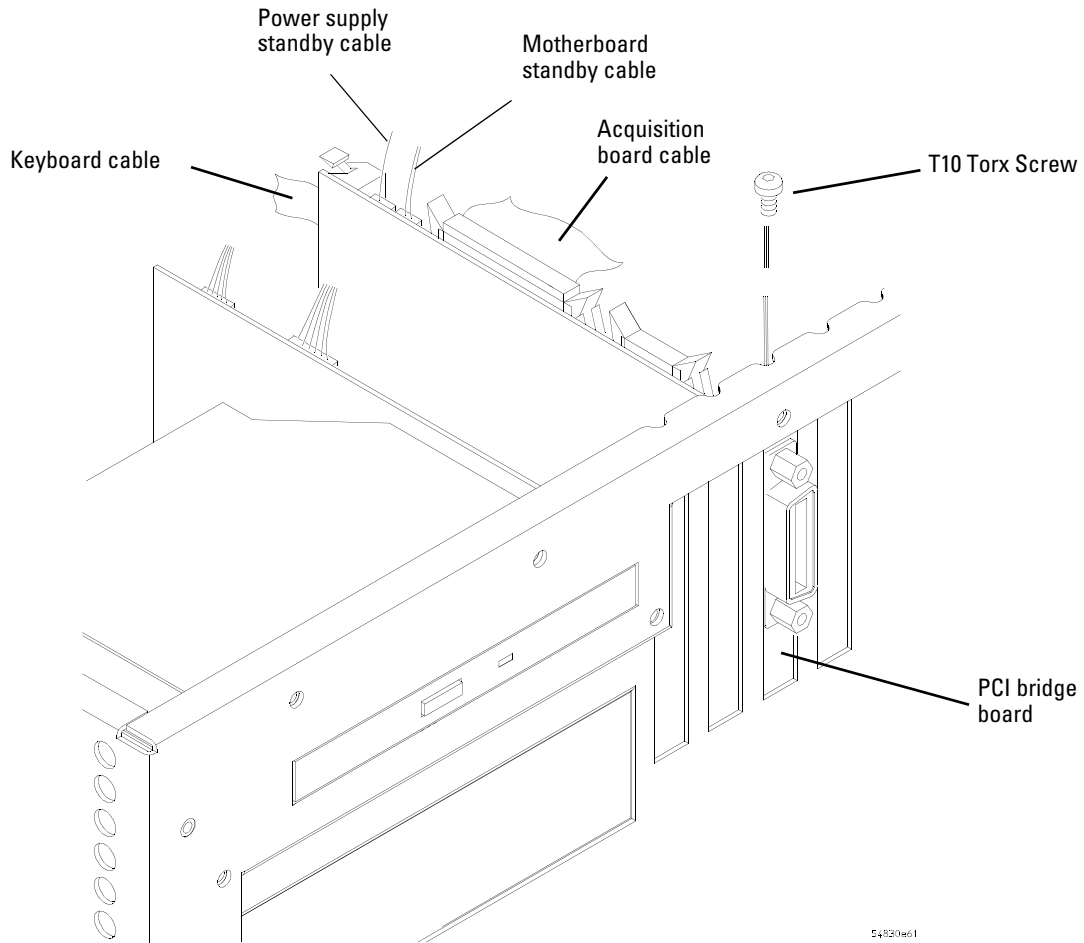

**Removing the PC interface and GPIB board**

---

## To remove and replace the display board

Use this procedure to remove and replace the display board. When necessary, refer to other removal procedures. The graphics in this chapter are representative of the oscilloscope at the time of this printing. Your unit may look different.

- 1 Disconnect the power cable and remove the top cover.
- 2 Disconnect these cables from the display board:
  - Backlight primary cable
  - Flat-panel display driver cable
- 3 Remove the Torx T10 screw that secures the display board to the chassis.

Figure 6-25

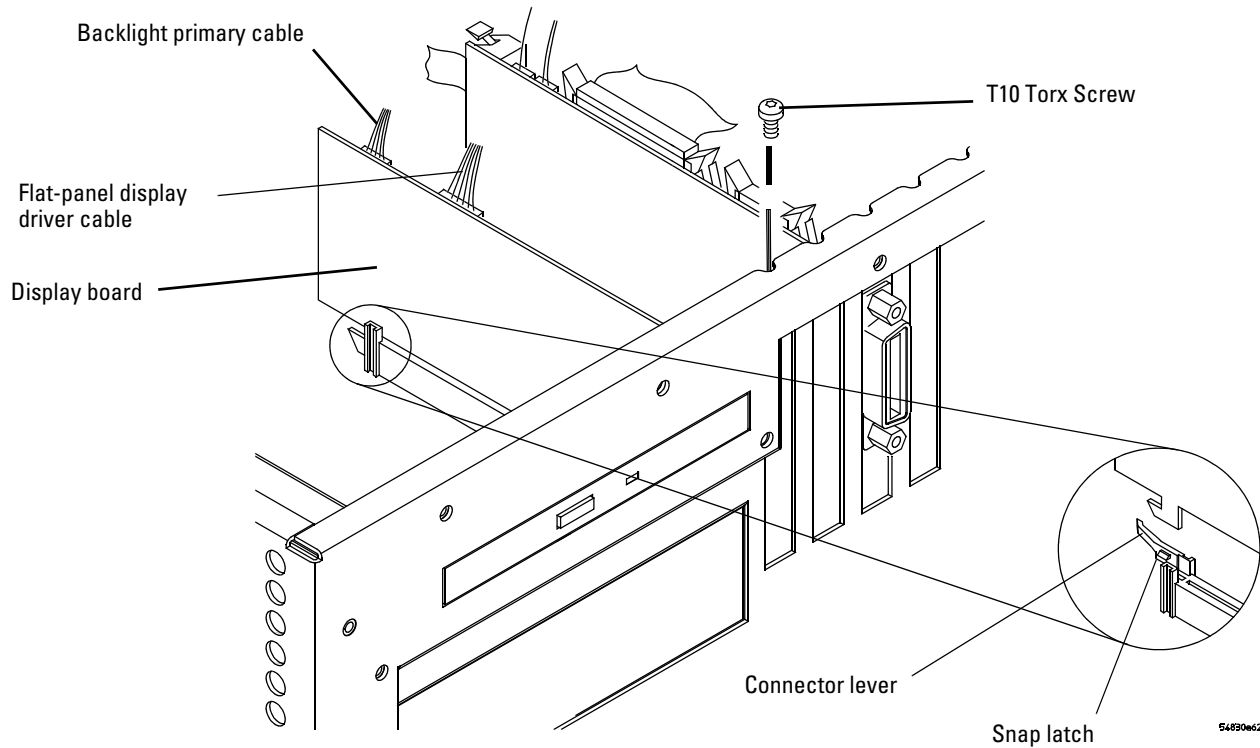

### Removing the display board

- 4 While pulling connector's lever back to release the latch, grasp the board at the top corners and pull it straight up until it is free of the card cage.
- 5 To replace the board, reverse the above procedure.  
Be sure to observe correct polarity on all cables when replacing the board.

## To remove and replace the hard disk drive

**No internal hard disk drive is installed in oscilloscopes that have option 017 installed.**

Use this procedure to remove and replace the hard disk drive. When necessary, refer to other removal procedures. The graphics in this chapter are representative of the oscilloscope at the time of this printing. Your unit may look different.

When replacing the hard disk drive, order the appropriate kit:

Oscilloscope Model Number	Hard Disk Drive Replacement Kit Part Number
5483xA/D, 5485xA and DSO80000A	54855-68704
DSO/MSO8000A, DSO80000B	D81004-68701

Instructions provided in the kit supercede the instructions in this chapter.

- 1 Disconnect the power cable and remove the top sleeve.
- 2 Remove the CD-ROM and hard drive cables from the cable clamps.

Figure 6-26

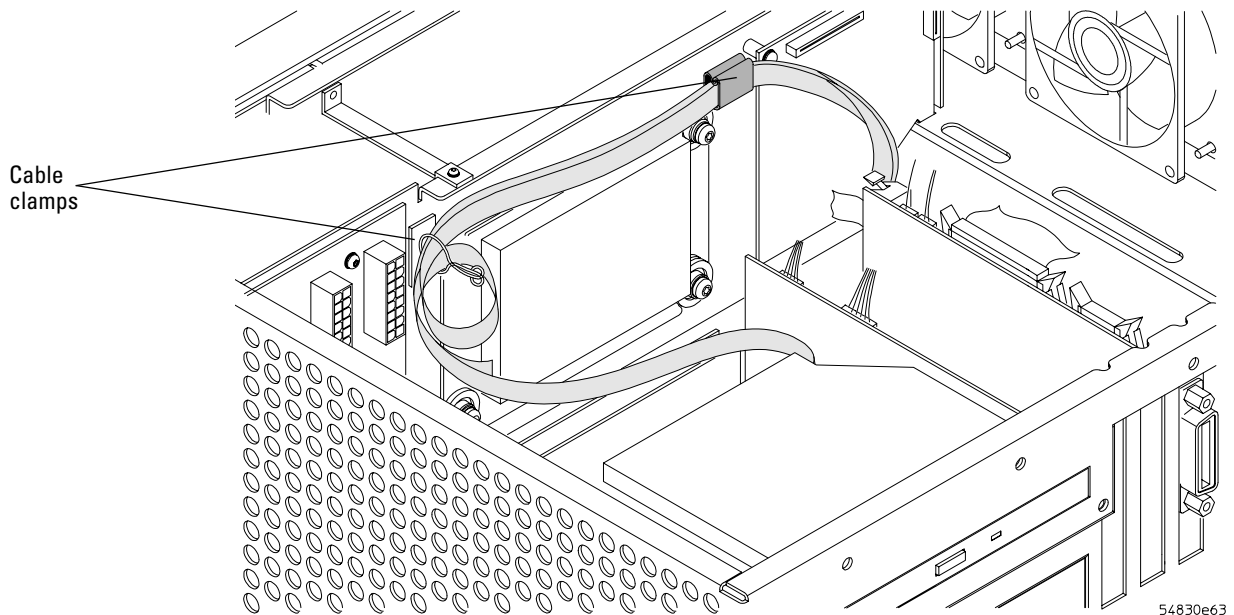

Removing cables from cable clamps

- 3 Remove the two Torx T20 screws holding the shock mount in place (See Figure 6-27).
- 4 Tilt the disk drive assembly forward and lift up to remove.

### CAUTION

DO NOT LET THE DISK DRIVE FALL!  
Support the drive while removing the screws so that the drive does not fall.

- 5 Remove the four Torx T10 screws holding the disk drive onto the shock mount.

Figure 6-27

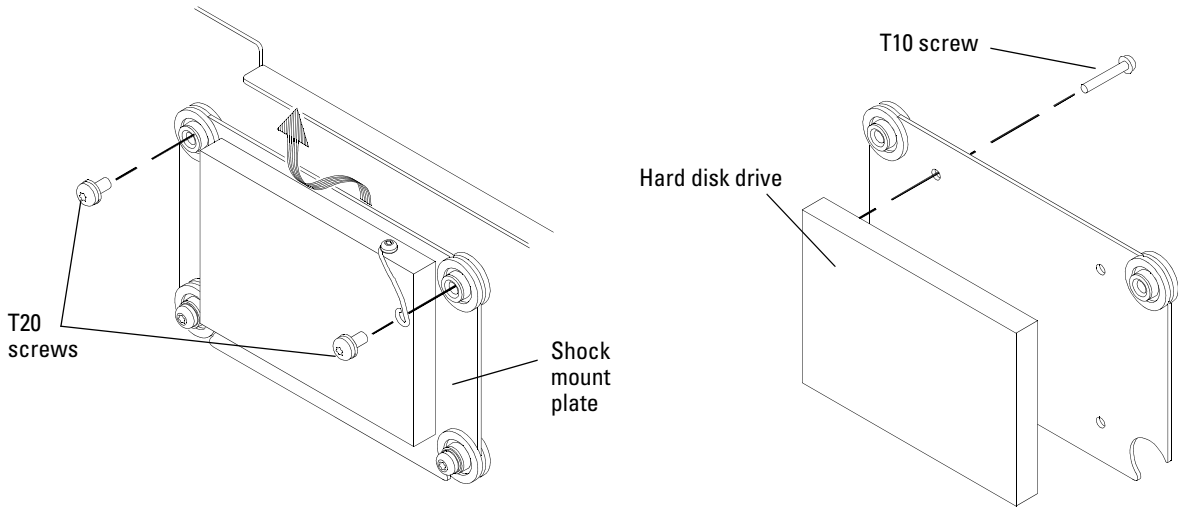

**Removing the hard disk drive**

**6** To replace the hard disk drive, reverse the above procedure.

**CAUTION**

**DO NOT OVERTIGHTEN THE SCREWS!**  
Do not overtighten the Torx T10 screws that secure the Hard Disk Drive to the bracket. Torque to 3 in-lb.

---

## To remove and replace the motherboard

Use this procedure to remove and replace the motherboard with the same brand (Intel or ADLINK). At some point after this manual was published it will become necessary to replace all Intel motherboards with ADLINK motherboards because the Intel motherboard is no longer available.

When necessary, refer to other removal procedures. The graphics in this chapter are representative of the oscilloscope at the time of this printing. Your unit may look different.

- 1 Disconnect the power cable and remove the top cover.
- 2 Remove the CD-ROM drive (see page 102).
- 3 Remove all cables from the PCI cards.
- 4 Remove all PCI cards from the motherboard (see page 117 for bracket removal).
- 5 Disconnect all cables from the motherboard.
- 6 Remove the six 5 mm port lock screws from the back panel connectors.
- 7 Remove the 5 short and 3 long Torx T10 screws holding the motherboard to the ATX tray.

Figure 6-28

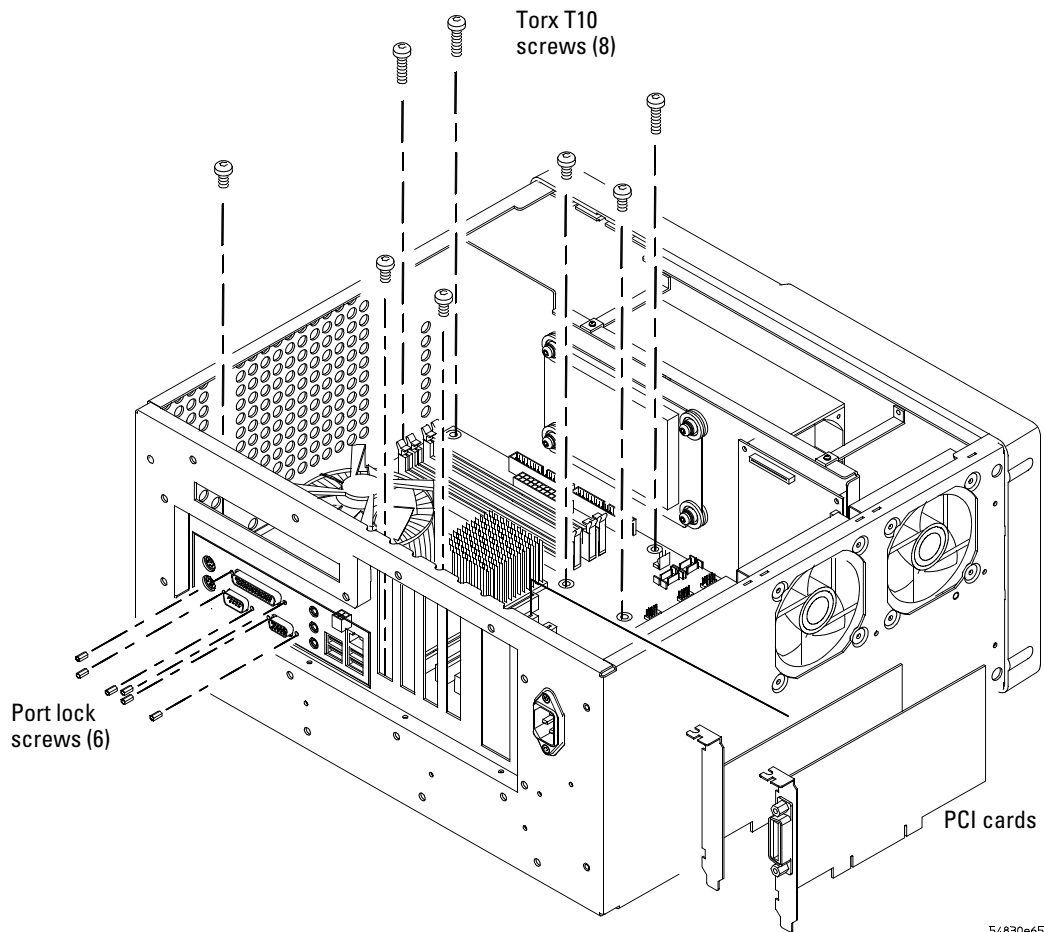

### Removing the motherboard

- 8 Lift the motherboard out of the tray.

- 9 To replace the motherboard assembly, reverse the above procedure.
- 10 Run the self test to verify the oscilloscope is operating properly.  
See “Self-Test Verification” on page 38.

---

## To replace the Intel motherboard with the ADLINK motherboard

When replacing an Intel motherboard with an ADLINK motherboard order the D8104-68700 M880 Motherboard Kit and follow these instructions.

- 1 Remove the CD-ROM drive using the instructions beginning on page 102.
- 2 Remove all cables from the PCI cards.
- 3 Remove all PCI cards from the motherboard.
- 4 Disconnect all cables from the motherboard.
- 5 Remove the six 5 mm port lock screws from the rear panel connectors.
- 6 Remove the 5 short and 3 long Torx T10 screws holding the motherboard to the ATX tray.

**Figure 6-29**

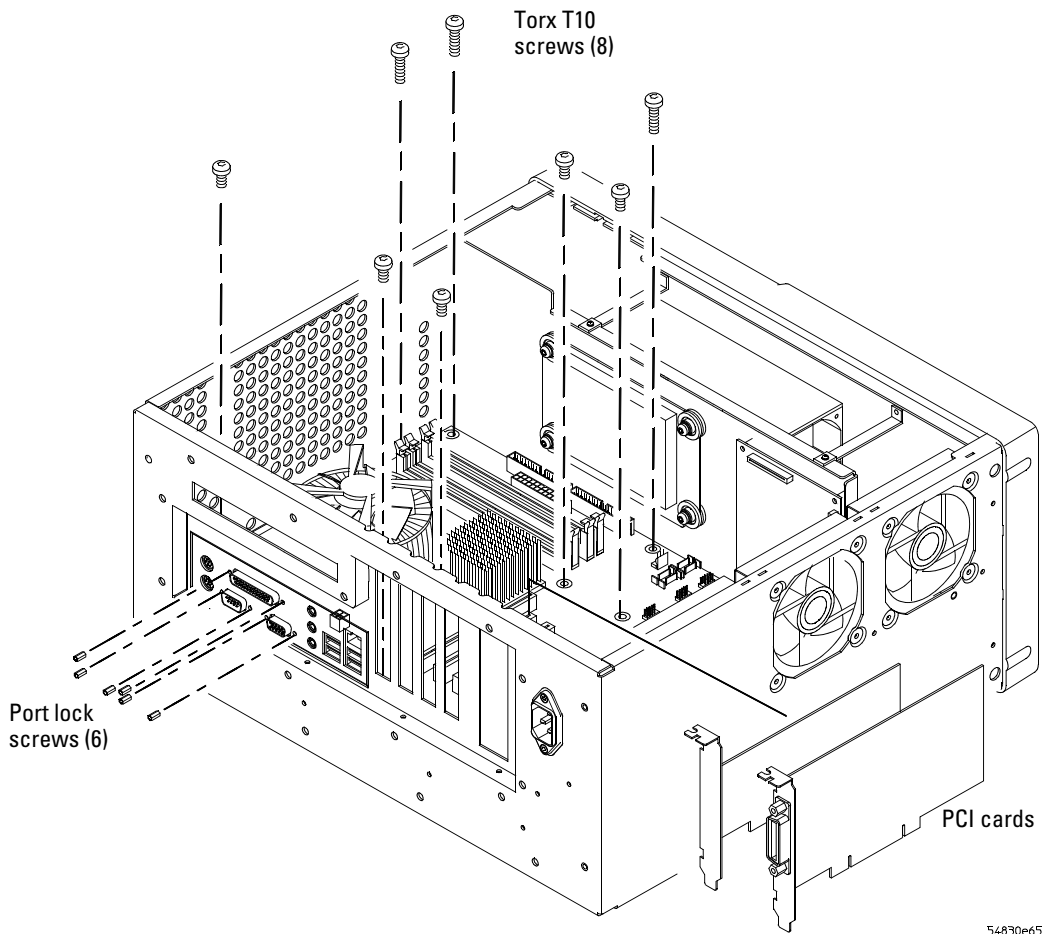

### Removing the motherboard

- 7 Remove the 8 T20 screws holding the tray to the rear panel.
- 8 Remove the 3 T10 screws holding the filler plate to rear panel and tray.
- 9 Remove the hard disk drive using the instructions beginning on page 120.
- 10 Lift tray with old motherboard from rear and slide to clear the rear panel clearing the three long standoffs under the tray remove the tray from the chassis.

- 11 Remove the AutoProbe board using the instructions beginning on page 104.
- 12 Using a 9/16" nut driver, remove the hex nuts that secure the BNC connectors to the front panel. (See See Figure 6-13 on page 108).
- 13 Remove the four Torx T15 screws that secure the chassis sides to the front panel assembly.

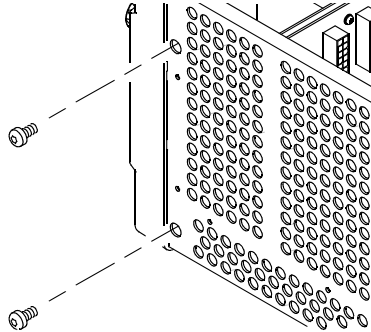
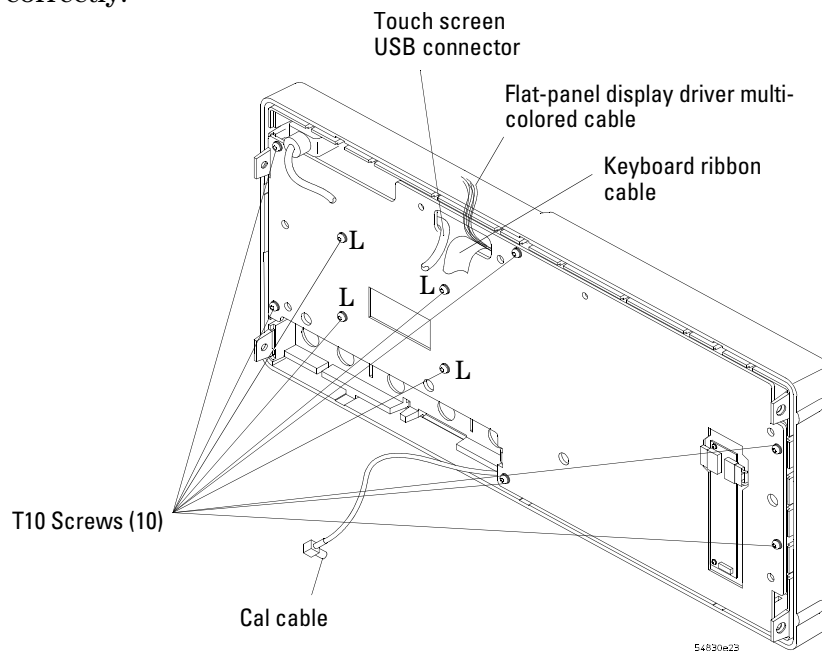

Figure 6-30

- 14 Remove the ten Torx T10 screws that secure the front panel cover plate to the front casting. The four screws marked "L" on the diagram are longer so be sure to re-assemble correctly.



**To replace the Intel motherboard with the ADLINK motherboard**

- 15 Turn the front panel cover plate over and remove the Touch Screen cable D8104-61604 and replace with D8104-61609. Route new cable through the hole. Secure with tape.

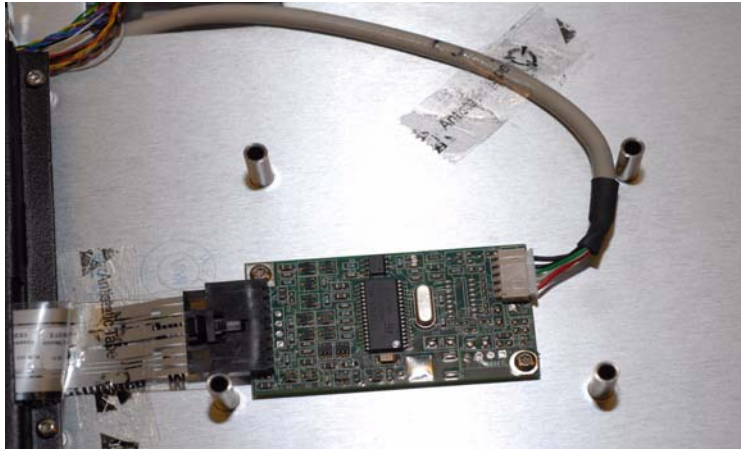

- 16 Turn front panel cover plate back over and re-assemble. When re-assembling, torque the ten Torx T10 screws to 5 in-lb.
- 17 Remove old Back Light cable D8104-61605 and replace with D8104-61607.



- 18 Pull back the Front Panel USB cover label and replace the old D8104-61602 USB cable with the new D8104-61608 cable.



- 19 Route cables through the chassis holes to prepare to reattach the front Panel assembly to the frame

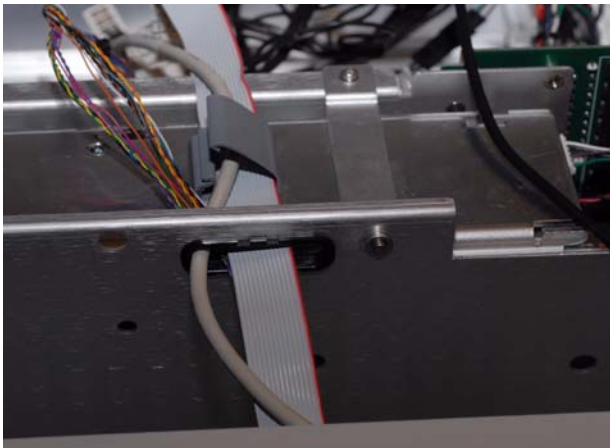

- 20 Re-install the Front Panel with four Torx T15 screws that secure the chassis sides to the front panel assembly. Torque the screws to 18 in-lb.
- 21 Using a 9/16" nut driver, install the five hex nuts that secure the BNC connectors to the front panel. Put the conical side of the nut toward the front-panel casting. Torque the hex nuts to 18 in-lb.
- 22 Reattach the AutoProbe to the mylar flex cable and pop the board back into place.
- 23 Using the new Motherboard Deck and new Motherboard:
- 24 Install the six 5 mm port lock screws securing the rear panel connectors.

- 25 Install the 5 short Torx T10 screws securing the motherboard to the deck.



- 26 Using the new Heat Sink and Fan Assembly attach the fan to the Motherboard and Deck. Connect the fan power cable to the fan CPU fan jack. Torque fan screws to 5 in-lb. Note: Do not use thermal grease on Heat Sink/Fan assembly. It comes with its own thermal type material.



- 27 Connect the new Motherboard Switch Cable to the motherboard.

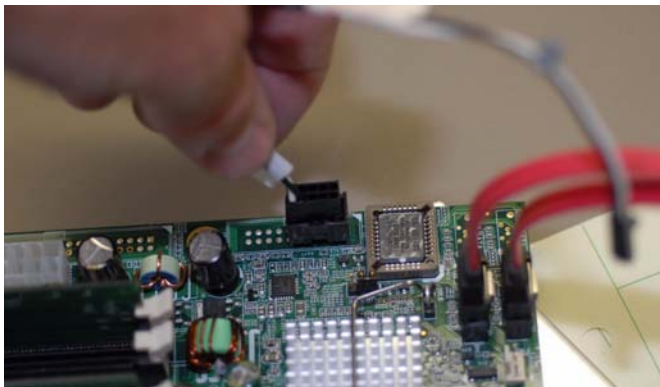

**28** Re-install the Motherboard assembly into the chassis:

- Install the 3 long Torx T10 screws and two short T10 into the tray holding the motherboard assembly to the frame chassis.

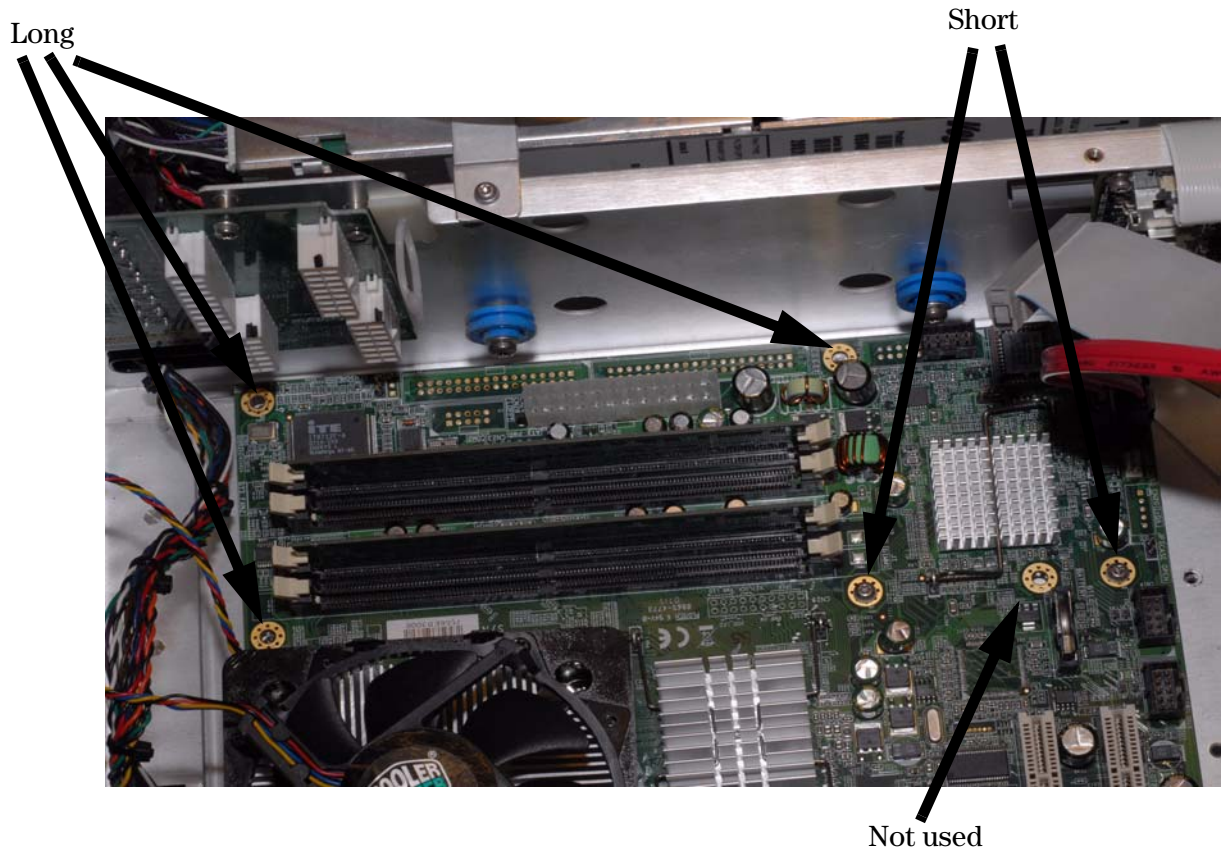

**29** Re-install eight short T20 screws in rear panel attaching deck to the frame chassis. Torque to 8 in-lb.

**30** Re-install three short T10 screws and filler plate to the rear panel. Torque to 5 in-lb.

**31** Re-install the Acquisition Interface PCI card into the slot marked GPIB on the rear panel.

**32** Connect new cables:

- a** Connect new display cable to motherboard.

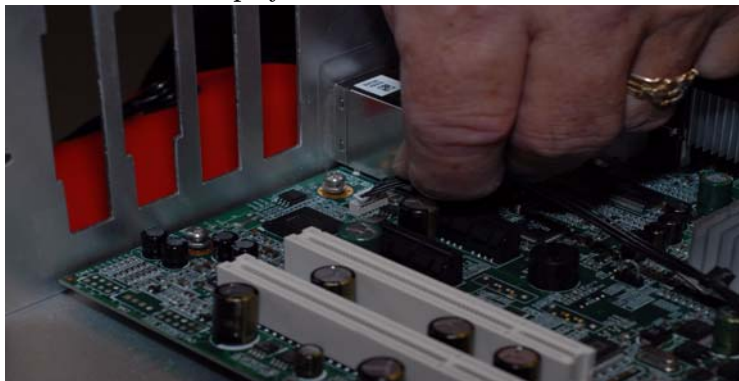

- b** Connect the two USB cables.

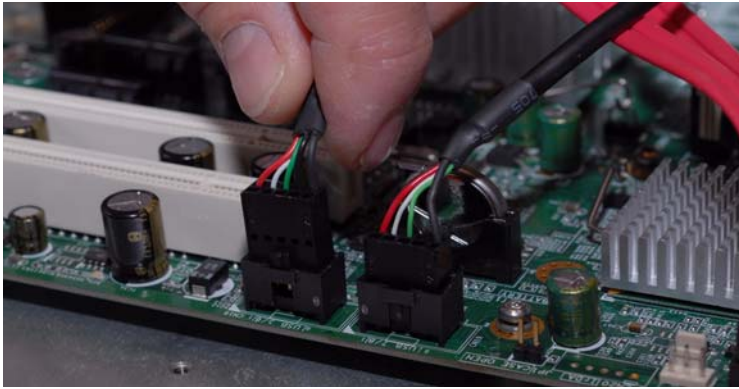

- c** Connect motherboard Switch cable to PCI card.



- 33** Replace the old USB cover label with the new one (part number D8104-94302 )provided in the kit.  
**34** Reconnect all other cables to their respective connectors.  
**35** Install all ISA slot filler plates.



- 36** Reinstall the hard drive according to the procedure that begins on page 120  
**37** Reinstall the CD-ROM drive according to the procedure that begins on page 102.  
**38** Re-dress all cables to their original positions, making sure they are in the appropriate tie downs and clamps.  
**39** Reinstall top cover, feet and handles.

---

## To remove and replace the power supply

Use this procedure to remove and replace the power supply. When necessary, refer to other removal procedures. The graphics in this chapter are representative of the oscilloscope at the time of this printing. Your unit may look different.

---

### WARNING

SHOCK HAZARD!

If the power supply is defective it could have a dangerous charge on some capacitors. This charge could remain for many days after removing power from the supply.

- 1 Disconnect the power cable and remove the top and bottom covers.
- 2 Disconnect the power sense cables from the acquisition board and the fan control board then feed them through the opening in the side of the bottom deck.

Figure 6-31

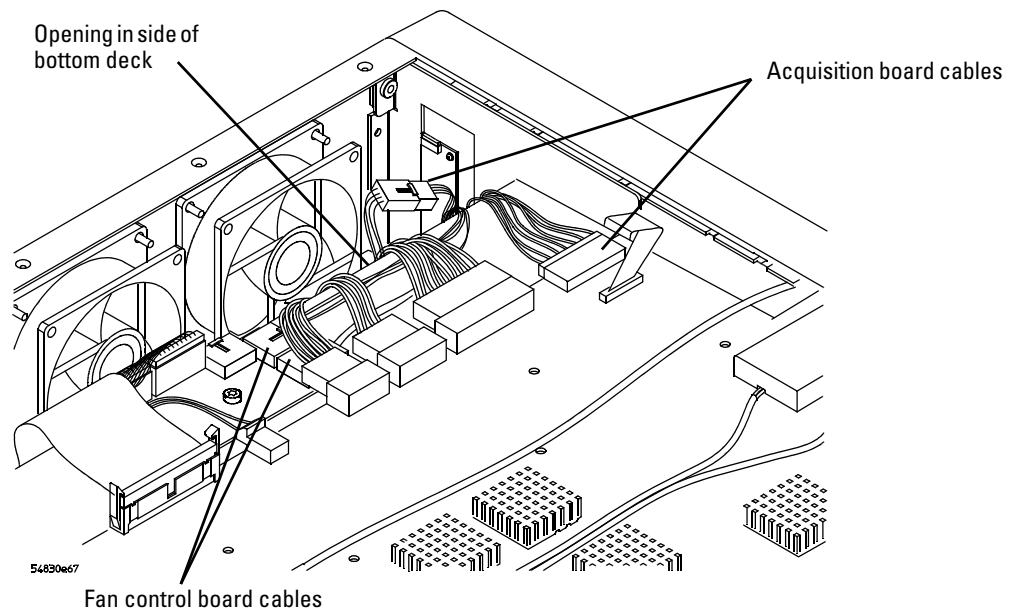

**Disconnecting cables from the bottom side of the frame**

3 Disconnect the following cables from the top side of the frame.

Figure 6-32

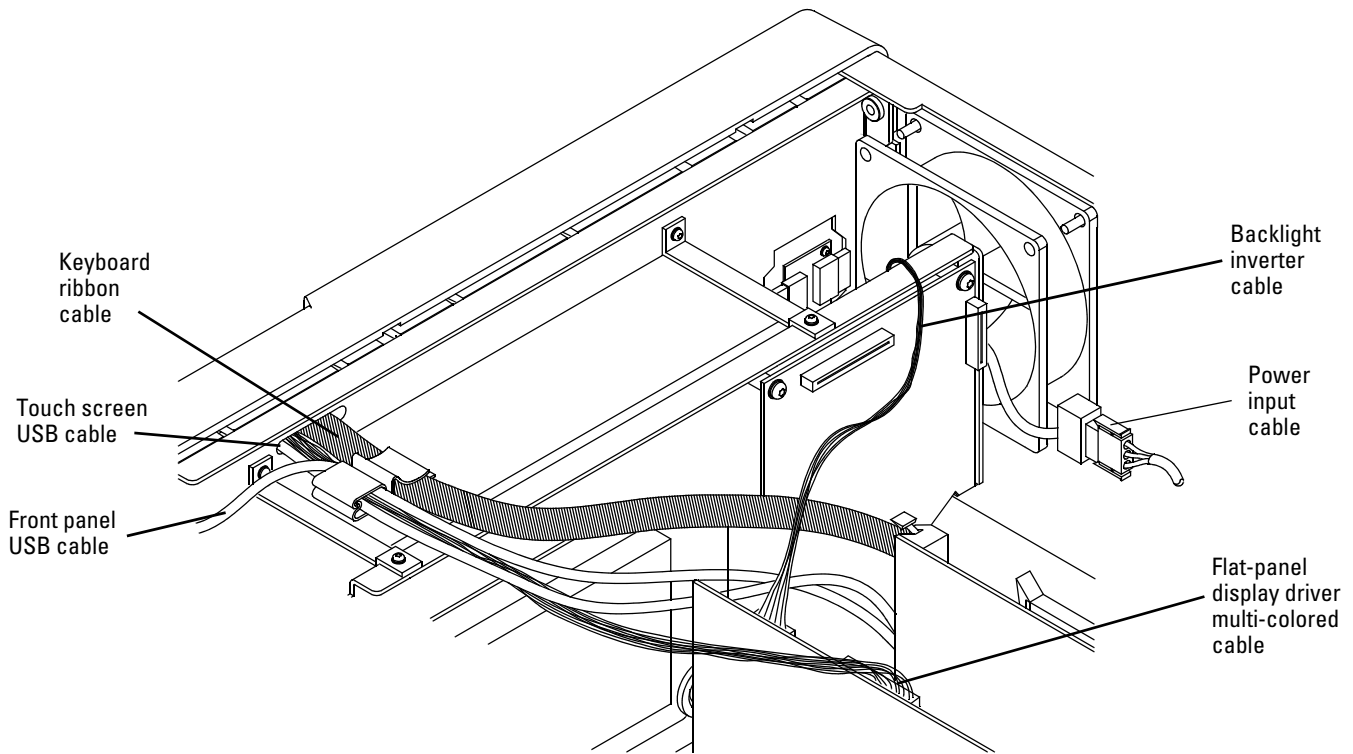

54830m13

Disconnecting cables from the top side of the frame

Figure 6-33

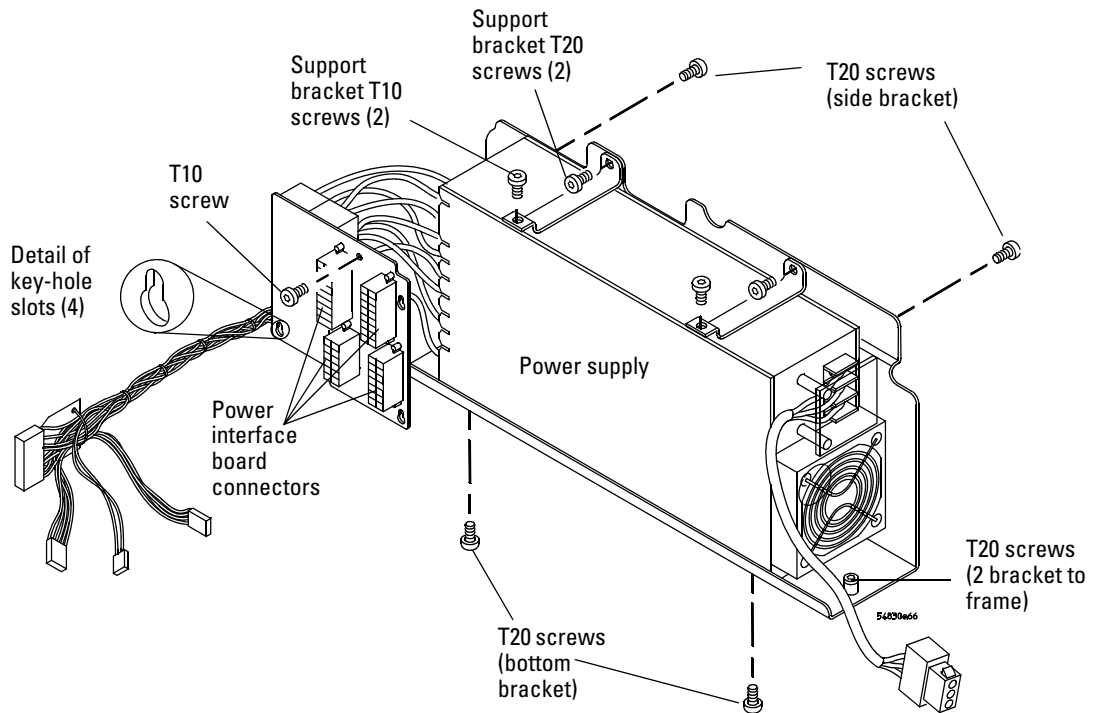

#### Removing the power supply and brackets

- 4 Disconnect the 4 cables from the power interface board connectors and remove the Torx T10 screw securing it to the frame.
- 5 Slide the power interface board up to remove it from the standoffs.  
Note the detail of the key-hole slots in See Figure 6-33.
- 6 Remove the two Torx T10 screws that hold the top support brackets to the chassis.  
When re-assembling, torque the two Torx T10 screws to 5 in-lb.
- 7 Remove the two Torx T20 screws that hold the top support brackets to the power supply bracket.  
When re-assembling, torque the Torx T20 screws to 18 in-lb.
- 8 Loosen the two Torx T20 screws at both ends of the power supply bracket that secure the bracket to the frame.  
These screws are part of the power supply bracket and can not be removed from the bracket.
- 9 Remove the power supply and power supply bracket from the chassis taking care to avoid damaging any of the cables.
- 10 Remove the two Torx T20 screws from the side of the power supply bracket.  
When re-assembling, torque the Torx T20 screws to 18 in-lb.
- 11 Remove the two Torx T20 screws from the bottom of the power supply bracket.  
When re-assembling, torque the Torx T20 screws to 18 in-lb.
- 12 Separate the power supply from the power supply bracket.
- 13 To replace the power supply, reverse the removal procedure.

---

## To remove and replace the fan controller board

Use this procedure to remove and replace the fan controller board. When necessary, refer to other removal procedures. The graphics in this chapter are representative of the oscilloscope at the time of this printing. Your unit may look different.

- 1** Disconnect the power cable and remove the bottom cover.
- 2** Disconnect the following cables from the fan control board.
  - Two fan power cables
  - Sense cable
  - Power harness cable
  - Control cable
  - Motherboard switch cable
- 3** Remove the two Torx T10 screws from the fan controller board.
- 4** Lift board out of chassis.
- 5** To re-install, reverse this procedure.

**Figure 6-34**

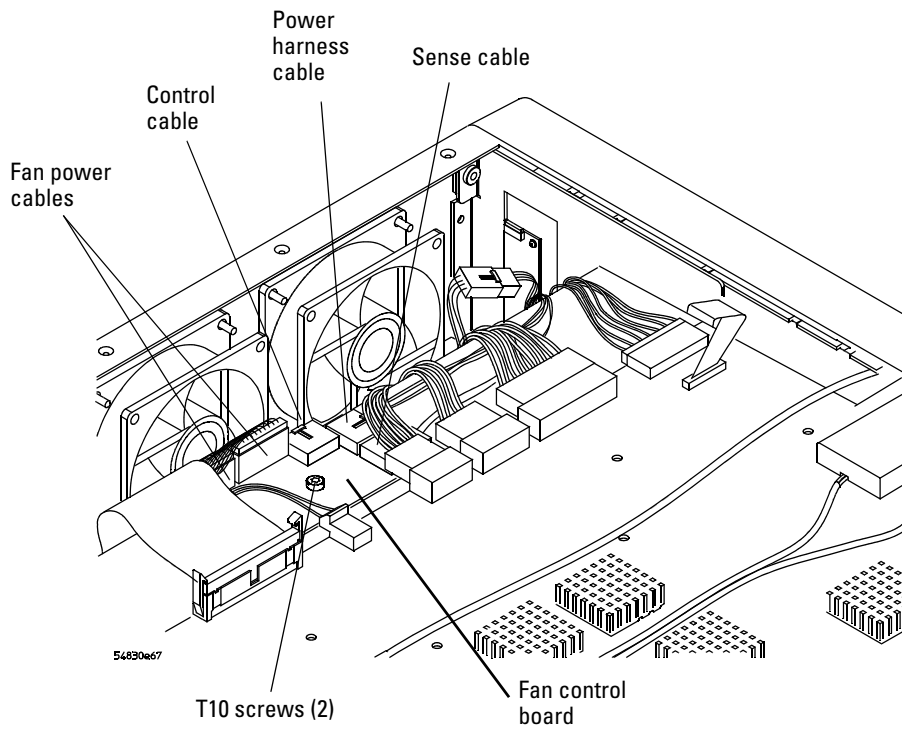

**Removing the fan controller board**

---

## To remove and replace a fan

Use this procedure to remove and replace a fan. When necessary, refer to other removal procedures. The graphics in this chapter are representative of the oscilloscope at the time of this printing. Your unit may look different.

---

### WARNING

AVOID INJURY!

The fan blades are exposed both inside and outside the chassis. Disconnect the power cable before working around the fan. Failure to observe these precautions may result in injury.

Use this procedure to remove and replace the fans. When necessary, refer to other removal procedures.

- 1 Disconnect the power cable and remove the top and bottom covers.
- 2 Disconnect the fan cable from the fan control board. See Figure 6-34.
- 3 Remove the four Torx T20 fan screws securing the fan to the chassis.

Figure 6-35

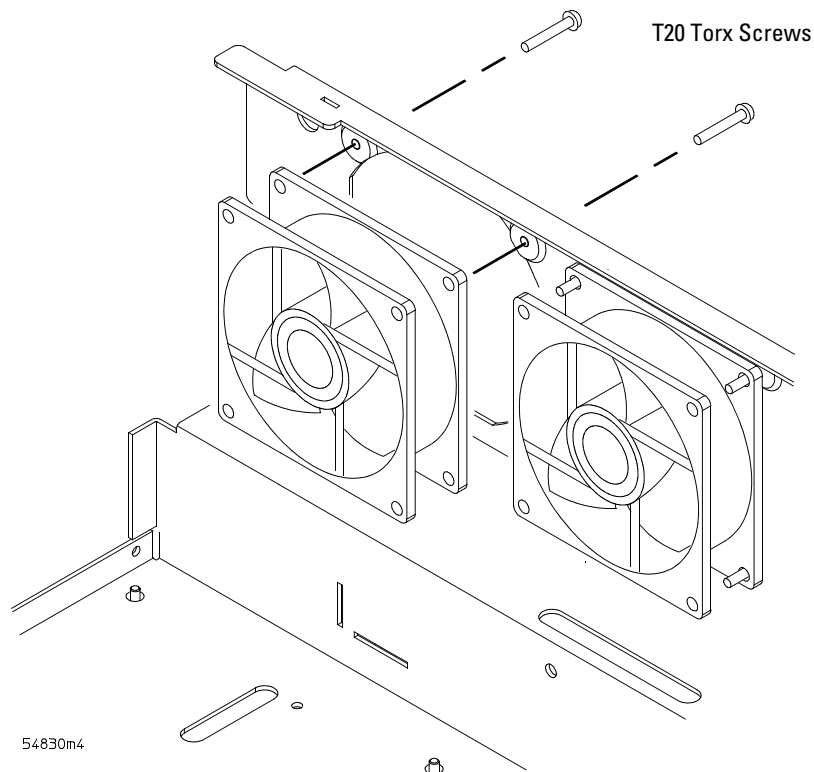

### Removing fan fasteners

---

### CAUTION

AVOID OVERHEATING THE OSCILLOSCOPE!

When replacing the fan, be sure the direction of the fan air flow is coming from the inside to the outside of the oscilloscope. Check the flow arrows on the fan and check for proper flow once power is applied to the oscilloscope. Improper air flow can overheat the oscilloscope.

- 4 To install the fan, reverse this procedure.

---

## To remove and replace the probe power and control assembly

Use this procedure to remove the probe power and control assembly. When necessary, refer to other removal procedures. The graphics in this chapter are representative of the oscilloscope at the time of this printing. Your unit may look different.

- 1 Disconnect the power cable and remove the top cover.
- 2 Disconnect the Mylar flex cable that connects the probe power and control assembly to the AutoProbe assembly.

The connector must be unlocked before you can remove the flex cable. See “To disconnect and connect Mylar flex cables” on page 101.

- 3 Disconnect the mylar flex cable from the probe power and control assembly.
- 4 Remove the two Torx T10 screws securing the probe power and control assembly to the chassis.

### **Avoid Interference with the Fan**

You may need to use a Torx key or stubby Torx driver to avoid interference with the fan.

- 5 Lift the probe power and control assembly out and away from the chassis.

**Figure 6-36**

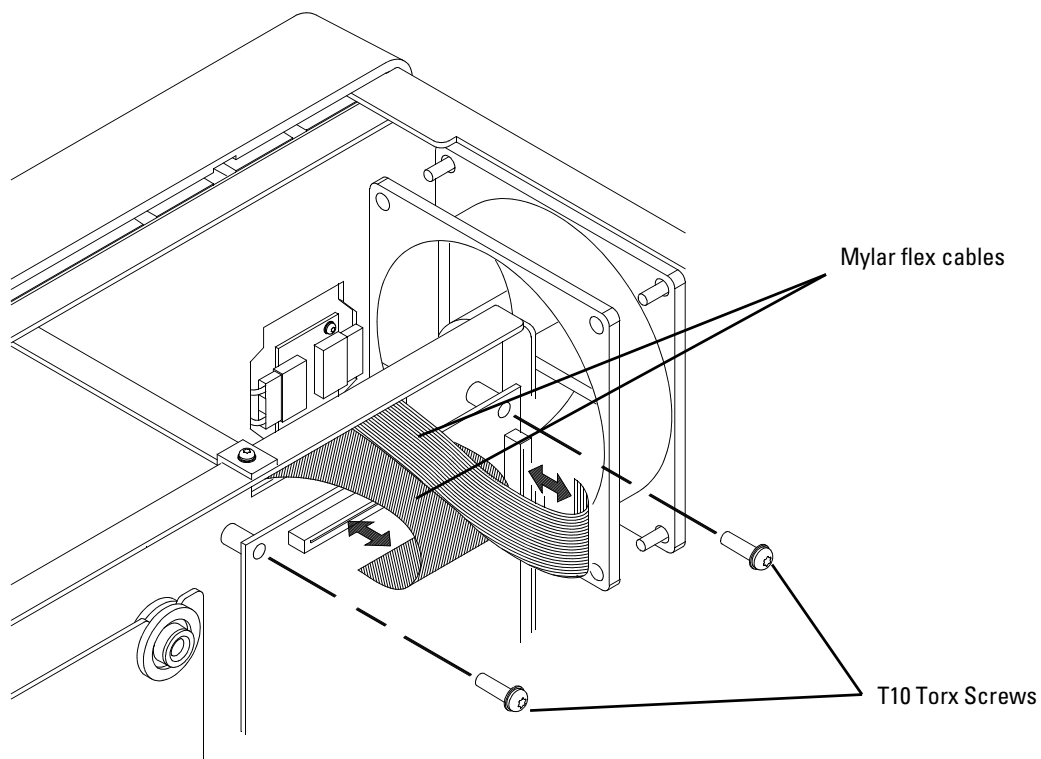

### **Remove the probe power and control assembly**

- 6 To replace the probe power and control assembly, reverse the above procedure.

When inserting the assembly, be sure the two tabs on the circuit board engage the two slots in the sheet metal. Also, be sure to carefully lock in the connector for the mylar flex cable when reattaching the cable. See “To disconnect and connect Mylar flex cables” on page 101.

Ordering Replaceable Parts 138  
    Listed Parts 138  
    Unlisted Parts 138  
    Direct Mail Order System 138  
    Exchange Assemblies 138  
Power Cords 139  
Exploded Views 140  
Replaceable Parts List 145

---

# Replaceable Parts

This chapter of the *Agilent Technologies Infiniium Oscilloscope Service Guide* includes information for ordering parts. Service support for this oscilloscope is replacement of parts to the assembly level. The replaceable parts include assemblies and chassis parts.

---

## Ordering Replaceable Parts

### Listed Parts

To order a part in the parts list, quote the Agilent Technologies part number, indicate the quantity desired, and address the order to the nearest Agilent Technologies Sales Office.

### Unlisted Parts

To order a part not listed in the parts list, include the oscilloscope part number, oscilloscope serial number, a description of the part (including its function), and the number of parts required. Address the order to the nearest Agilent Technologies Sales Office.

### Direct Mail Order System

Within the USA, Agilent Technologies can supply parts through a direct mail order system. There are several advantages to this system:

- Direct ordering and shipping from the Agilent Technologies parts center in California, USA.
- No maximum or minimum on any mail order. (There is a minimum amount for parts ordered through a local Agilent Technologies Sales Office when the orders require billing and invoicing.)
- Prepaid transportation. (There is a small handling charge for each order.)
- No invoices.

In order for Agilent Technologies to provide these advantages, please send a check or money order with each order.

Mail order forms and specific ordering information are available through your local Agilent Technologies Sales Office. Addresses and telephone numbers are located in a separate document shipped with the manuals.

### Exchange Assemblies













Some parts used in this oscilloscope have been set up for an exchange program. This program allows the customer to exchange a faulty assembly with one that has been repaired, calibrated, and performance-verified by the factory. The cost is significantly less than that of a new part. The exchange parts have a part number in the form XXXXX-695XX.

After receiving the repaired exchange part from Agilent Technologies, a United States customer has 30 days to return the faulty assembly. For orders not originating in the United States, contact the local Agilent Technologies service organization. If the faulty assembly is not returned within the warranty time limit, the customer will be charged an additional amount. The additional amount will be the difference in price between a new assembly and that of an exchange assembly.

## Power Cords

This oscilloscope is equipped with a three-wire power cord. The type of power cord plug shipped with the oscilloscope depends on the country of destination. The following figure shows option numbers of available power cords and plug configurations.

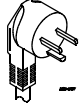
### Power Cords

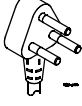
Plug Type	Cable Part Number	Plug Type	Cable Part Number
Opt 900 (U.K.) 	8121-1579	Opt 918 (Japan) 	8121-1603
Opt 901 (Australia) 	8121-1581	Opt 919 (Israel) 	8121-1662
Opt 902 (Europe) 	8121-1580	Opt 920 (Argentina) 	8121-1599
Opt 903 (U.S.A.) 	8121-1609	Opt 921 (Chile) 	8121-1600
Opt 906 (Switzerland) 	8121-1602	Opt 922 (China) 	8121-1606
Opt 912 (Denmark) 	8121-1601	Opt 927 (Thailand) 	8120-0674
Opt 917 (India) 	8121-1604	Opt 923 (South Africa) Opt 930 (Brazil) Opt 931 (Taiwan) Opt 932 (Cambodia)	8121-1641 8121-1613 8121-1637 8121-1633

## Exploded Views

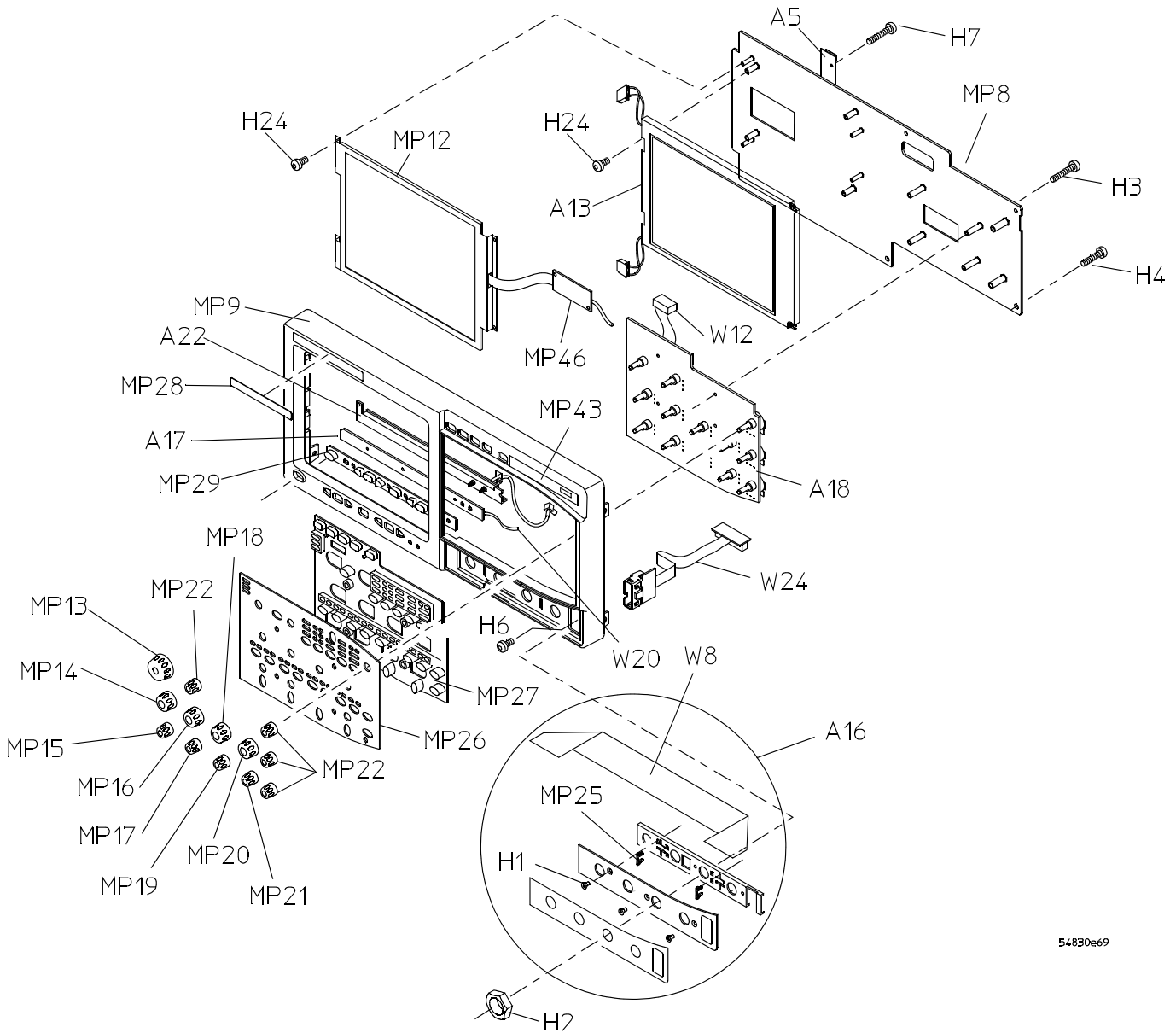

54830e69

Front Frame and Front Panel

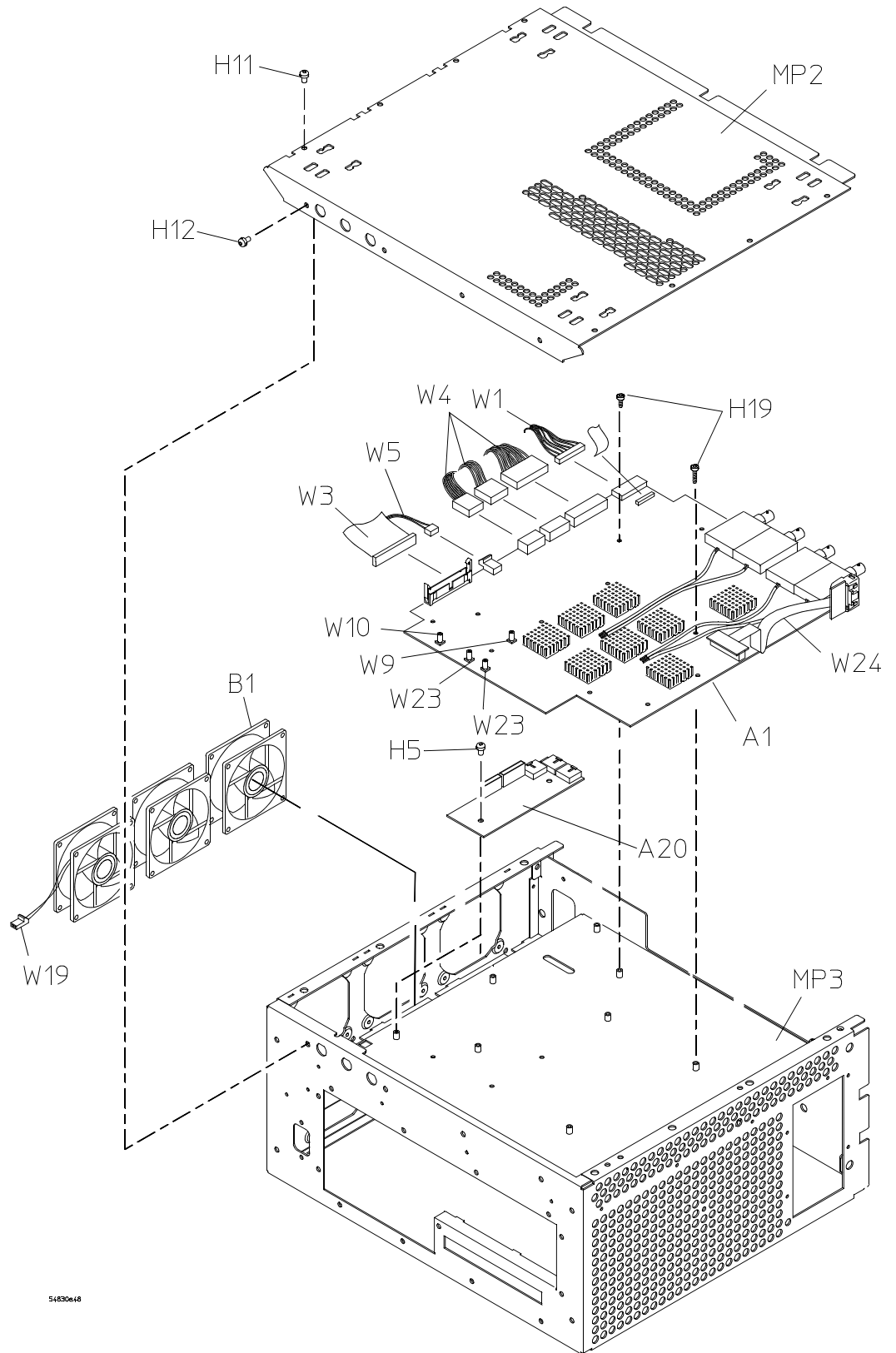

54830e48

Fan and Acquisition Assembly

Chapter 7: Replaceable Parts  
Exploded Views

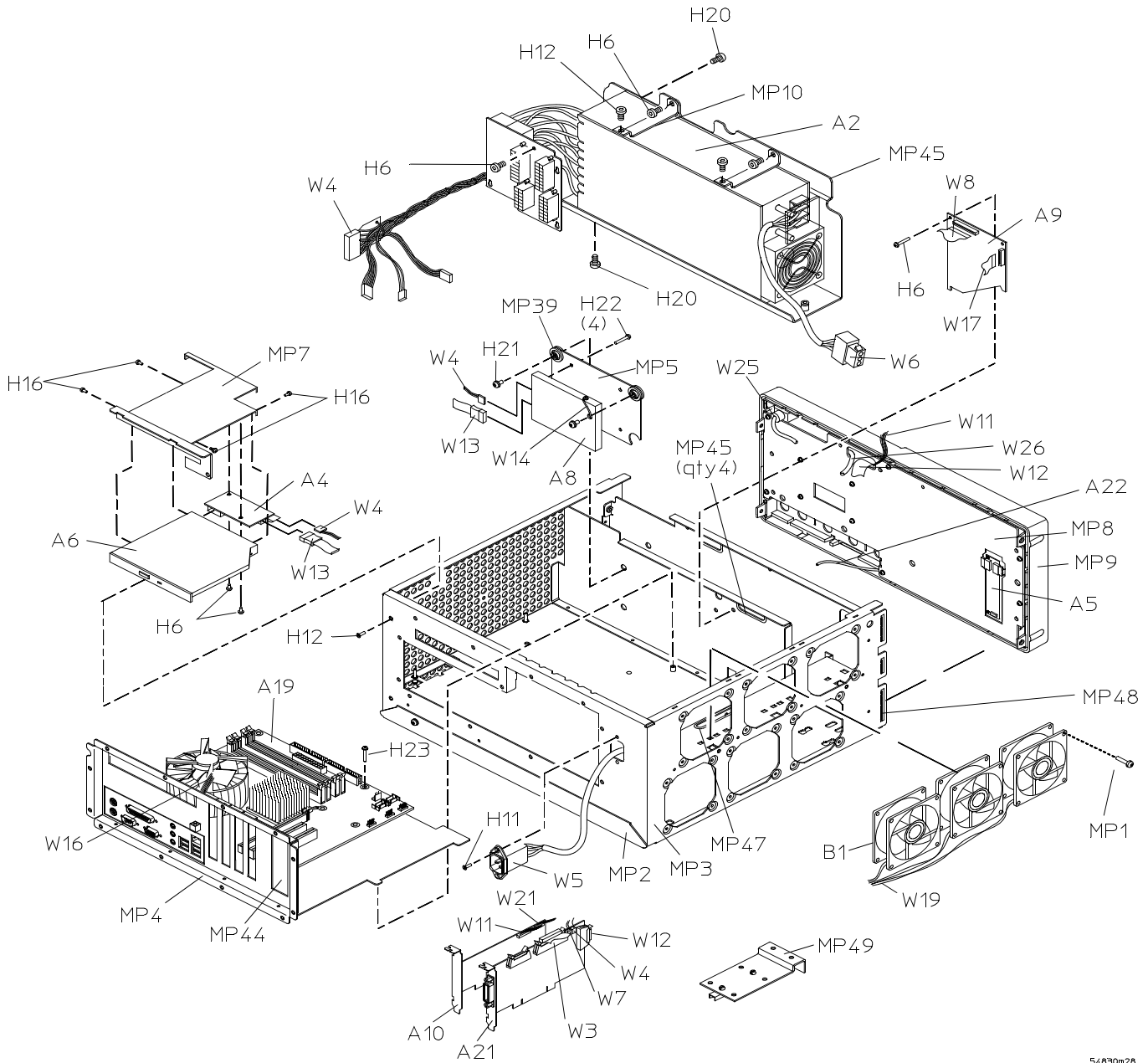

54830m28

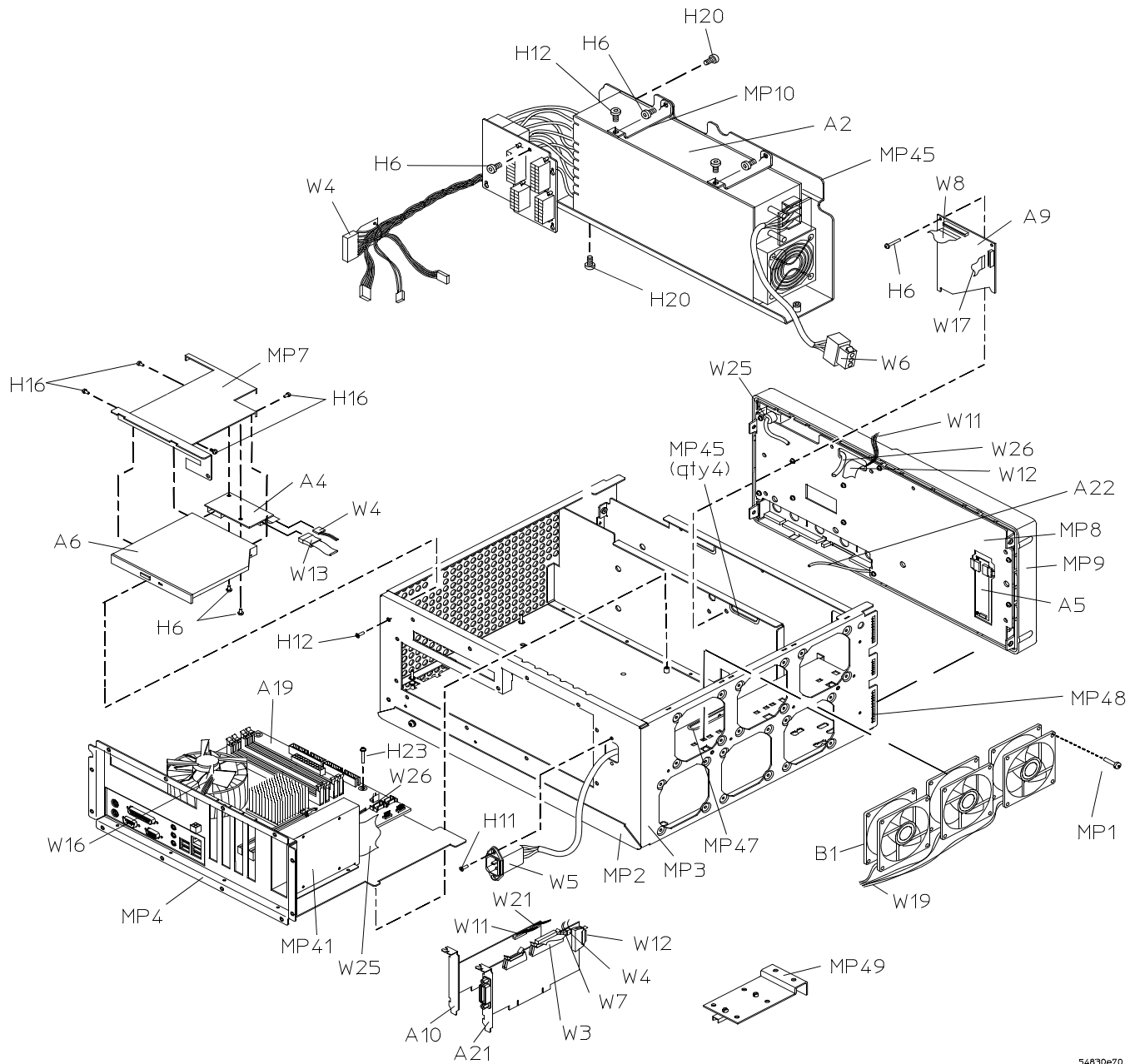

54890e70

Power Supply and PC Motherboard With Option 017

Chapter 7: Replaceable Parts  
Exploded Views

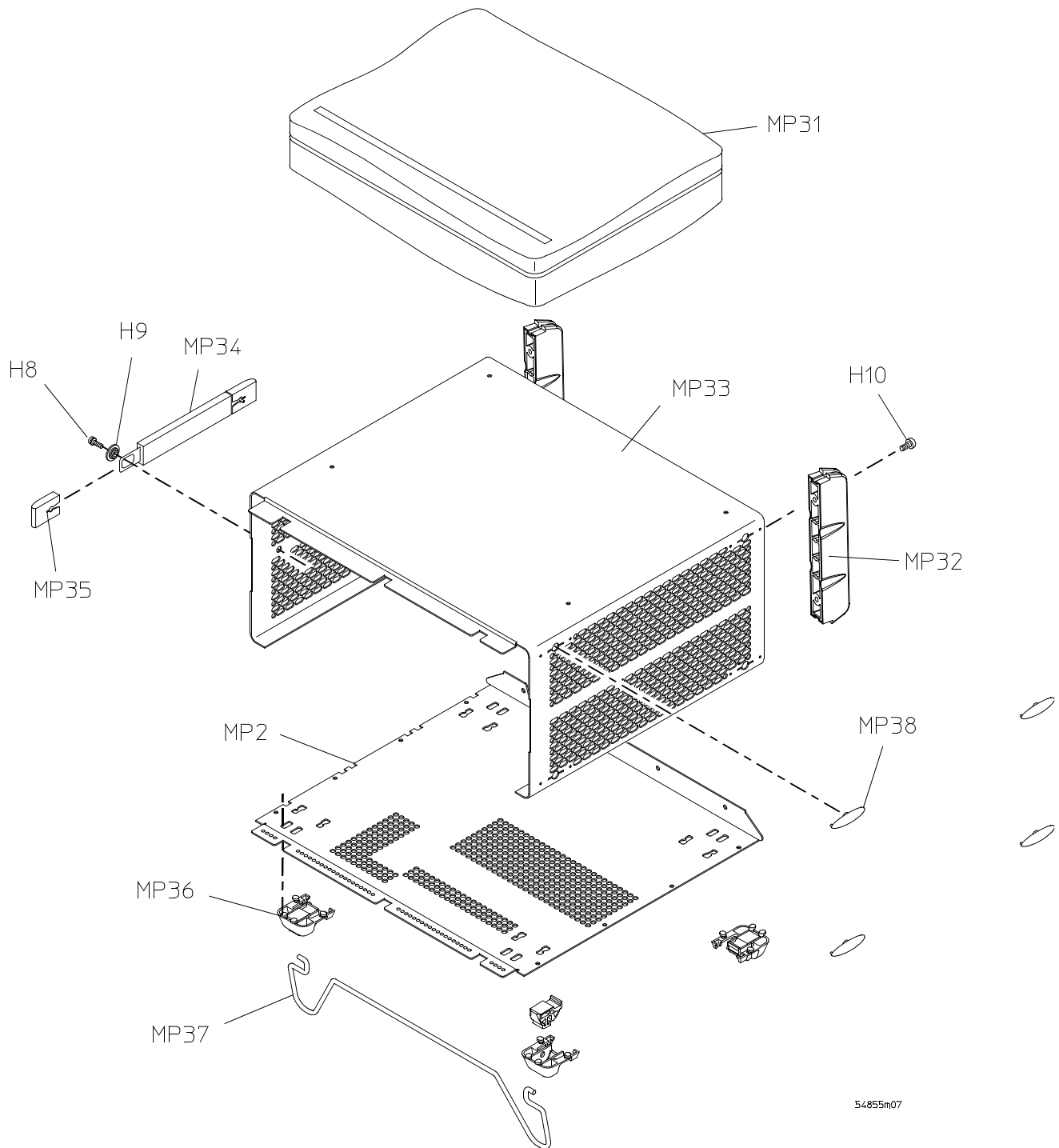

54855m07

**Sleeve and Accessory Pouch**

---

## Replaceable Parts List

The following table is a list of replaceable parts and is organized as follows:

- Exchange assemblies in alphanumeric order by reference designation.
- External chassis parts in alphanumeric order by reference designation. These parts are generally those that take the physical wear and tear of use.
- Internal parts in several categories. Each category is in alphanumeric order by reference designation. Replacing these parts generally requires opening the cabinet.

The information given for each part consists of the following:

- Reference designation.
- Agilent Technologies part number.
- Total quantity (Qty) in an oscilloscope or on an assembly. The total quantity is given once and at the first appearance of the part number in the list.
- Description of the part.

---

### Replaceable Parts

Ref. Des.	Agilent Part Number	Qty	Description
<b>Exchange Assemblies</b>			
A1	54831-66523	1	4-CH ACQUISITION ASSEMBLY (DSO8064A)
A1	54832-66523	1	4-CH ACQUISITION ASSEMBLY (DSO8104A)
A1	54831-66524	1	4-CH ACQUISITION ASSEMBLY (MSO8064A)
A1	54832-66524	1	4-CH ACQUISITION ASSEMBLY (MSO8104A)
<b>External Chassis Parts</b>			
MP13	54801-47403	1	KNOB 24 MM GRAY
MP14	54801-47408	1	KNOB 18 MM YELLOW
MP15	54801-47404	1	KNOB 12 MM YELLOW
MP16	54801-47409	1	KNOB 18 MM GREEN
MP17	54801-47405	1	KNOB 12 MM GREEN
MP18	54801-47410	1	KNOB 18 MM PURPLE
MP19	54801-47406	1	KNOB 12 MM PURPLE
MP 20	54801-47411	1	KNOB 18 MM PINK
MP21	54801-47407	1	KNOB 12 MM PINK
MP22	54801-47401	4	KNOB 12 MM GRAY
MP26	54832-94330	1	FRONT PANEL 4-CH LABEL (DSO models)
MP26	54838-94330	1	FRONT PANEL 4-CH LABEL (MSO models)
MP28	D8064-94301	1	LOGO LABEL (DSO8064A)
MP28	D8104-94301	1	LOGO LABEL (DSO8104A)
MP28	M8064-94301	1	LOGO LABEL (MSO8064A)
MP28	M8104-94301	1	LOGO LABEL (MSO8104A)
MP31	54810-68701	1	ACCESSORY POUCH
NOT SHOWN	54810-42201	1	FRONT PANEL COVER
MP32	5042-1798	2	REAR FEET
MP34	54810-44901	1	MOLD OVER HANDLE
MP35	54810-45001	2	END CAP HANDLE
MP36	54810-61001	4	BOTTOM FEET w/INSERT
MP37	54810-03702	1	TILT STAND
MP38	01680-41002	4	SIDE FOOT
MP43	D8104-94302	1	USB LABEL
W18	8120-1521	1	CABLE-POWER (standard 125V USA)

Chapter 7: Replaceable Parts  
**Replaceable Parts List**

---

**Replaceable Parts**

---

<b>Ref. Des.</b>	<b>Agilent Part Number</b>	<b>Qty</b>	<b>Description</b>
W18	8120-1703	1	CABLE-POWER (Option 900-UK)
W18	8120-0696	1	CABLE-POWER (Option 901-AUSTL)
W18	8120-1692	1	CABLE-POWER (Option 902-EUR)
W18	8120-2296	1	CABLE-POWER (Option 906-SWIT)
W18	8120-2957	1	CABLE-POWER (Option 912-DEN)
W18	8120-4600	1	CABLE-POWER (Option 917-AFRICA)
W18	8120-4754	1	CABLE-POWER (Option 918-JAPAN)
W18	8120-6799	1	CABLE-POWER (Option 919-ISRAEL)
W18	8120-6871	1	CABLE-POWER (Option 920-ARGENTINA)
W18	8120-6979	1	CABLE-POWER (Option 921-CHILE)
W18	8120-8377	1	CABLE-POWER (Option 922)
W18	8120-8871	1	CABLE-POWER (Option 927-THAILAND)
<b>Electrical Assemblies</b>			
A2	D8064-62601	1	POWER SUPPLY SUBASSEMBLY
A5	0950-4635	1	INVERTER BOARD
A13	2090-0911	1	LCD XGA DISPLAY
MP46	54858-66513	1	USB TOUCHSCREEN CONTROLLER BOARD, PROGRAMMED
A22	54857-61201	1	CAL BRACKET SUBASSEMBLY
<b>PC Motherboard</b>			
A4	0960-2522	1	CONVERTER CARD-ATAPI TO SATA
A6	0950-4741	1	CD ROM Drive
A8		1	HARD DISK DRIVE with SOFTWARE (NOT ON OPTION 017 REMOVABLE DRIVE) DSO/MSO8000A (with Intel motherboard): Part number D81004-68701 DSO/MSO8000A (with ADLINK motherboard): Part number D81004-68702 5483xA/D, 5485xA: Part number 54855-68704
Replace A19 motherboard with same type.			
A19	D81004-68703	1	MOTHERBOARD SUBASSEMBLY (Includes new deck and heat sink.)
A19	D81004-68809	1	MOTHERBOARD SUBASSEMBLY
A19	D8104-68700	1	MOTHERBOARD SUBASSEMBLY
<b>All Configurations</b>			
A9	54810-66506	1	PROBE INTERFACE BOARD
A12	0960-2530	1	DISPLAY BOARD (installed only with Intel motherboard)
A16	54832-68703	0	4-CH REPLACEMENT I/O KIT (DSO models)
A16	54838-68703	0	4-CH REPLACEMENT I/O KIT (MSO models)
A17	54826-66507	1	KEYBOARD - CURSOR
A18	54832-66504	1	KEYBOARD - 4CH (DSO models)
A18	54826-66504	1	KEYBOARD - 4CH (MSO models)
A20	D8064-66401	1	FAN CONTROLLER BOARD
A21	54855-66515	1	INTERFACE & GPIB BOARD
<b>Fans</b>			
B1	3160-4134	6	12 V FAN
<b>Internal Chassis Parts</b>			
H1	0515-2219	3	SCREW-MACH; M2.5 X 0.45 5MM-LG ; T8
H2	54503-25701	4	HEX NUT BNC
H3	0515-1025	3	SCREW-MACH; M3 X 0.5 26MM-LG; T10; WASHER
H4	0515-1410	4	SCREW-MACH; M3 X 0.5 20MM-LG; T10; PAN; WASHER
H5	0515-0430	13	SCREW-MACH; M3 X 0.5 6MM-LG; T10; PAN; WASHER

---

**Replaceable Parts**

---

<b>Ref. Des.</b>	<b>Agilent Part Number</b>	<b>Qty</b>	<b>Description</b>
H6	0515-0372	22	SCREW-MACH; M3 X 0.5 8MM-LG ; T10; WASHER
H7	0515-1246	2	SCREW-MACH; M3 X 0.5 6MM-LG PAN-HD; T10; PATCH LOCK
H8	5021-4302	4	SCREW MACH;M4X0.7 20MM-LG
H9	54801-24702	1	SPACER-STRAP HANDLE
H10	0515-2195	4	SCREW-MACH; M4 X 0.7 40MM-LG ; T20; WASHER
H11	0515-1103	10	SCREW-MACH M3 X 0.5 10MM-LG ; T10
H12	0515-0380	17	SCREW-MACH; M4 X 0.7 10MM-LG; T20 , PAN; WASHER:
H14	0515-0436	4	SCREW-MACH; M4 X 0.7 18MM-LG ; T20; WASHER (NOT ON OPTION 017)
H15	0515-0375	3	SCREW-MACHINE ASSEMBLY M3 X 0.5 16MM-LG
H16	0515-0365	6	SCREW-MACHINE ASSEMBLY M2 X 0.4 4MM-LG
H18	0515-2691	2	SCREW-MACH: M2.6 X 0.45 6MM-LG PAN-HD; T8; LOCK
H19	0515-4804	12	SCREW-MACH PAN-HD M3X0.5-THD 12.0-MM-LG
H20	0515-0433	2	SCREW-MACH; M4.0 X 0.70; 8 MM LONG; T20; WASHER
H21	0515-0383	4	SCREW-MACH; M4.0 X 0.70; 16 MM LONG; T20; WASHER
H22	0515-0374	4	SCREW-MACH; M3.0 X 0.50; 10 MM LONG; T10; WASHER
H23	0515-0666	1	SCREW-MACH; M3.0 X 0.50; 18 MM LONG; T10; WASHER
H24	0515-1940	4	SCREW-MACH; M2.5 X 0.45; 6 MM LONG; T8; LOCK
MP1	0624-1066	24	FAN SCREWS
MP2	D8064-04105	1	SLEEVE BOTTOM
MP3	D8064-60101	1	CHASSIS ASSEMBLY
MP4	D8104-60103	1	MOTHERBOARD TRAY
MP5	54857-01211	1	HARD DRIVE BRACKET (NOT ON OPTION 017)
MP7	D8104-01201	1	CD-ROM MOUNT BRACKET
MP8	D8104-04103	1	FRONT FRAME BACK PLATE
MP9	54832-40502	1	FRONT FRAME
MP10	54857-01215	2	SUPPORT BRACKET
MP12	D8104-01205	1	TOUCH SCREEN
MP25	54801-09101	2	SPRING STEEL
MP27	54831-41903	1	KEYPAD 4-CH (DSO models)
MP27	54831-41901	2	KEYPAD 4-CH (MSO models)
MP29	54826-41902	1	CURSOR KEYPAD
MP33	54810-04104	1	SLEEVE TOP
MP39	1520-0238	4	GROMET (NOT ON OPTION 017)
NOT SHOWN	7101-1123	1	REMOVEABLE HARD DRIVE FRAME AND CARRIER (WITH OPTION 017)
MP41	54857-01216	1	REMOVEABLE HARD DRIVE BRACKET (WITH OPTION 017)
MP42	1252-7017	4	RETAINER CLIP
MP44	54857-60201	1	ATX PANEL COVER
MP45	54857-01213	1	POWER SUPPLY BRACKET
MP46	0960-2535	1	USB CONTROLLER BOARD
MP47	8160-0950	1.5	RFI STRIP
NOT SHOWN	1400-3249	1	CABLE TIE
MP49	54857-01218	1	PCI BRACKET ASSEMBLY
<b>Cables</b>			
W1	D8064-61602	1	SENSE CABLE
W3	54826-61606	1	ACQUISITION SIGNAL CABLE

---

Chapter 7: Replaceable Parts  
**Replaceable Parts List**

---

**Replaceable Parts**

---

<b>Ref. Des.</b>	<b>Agilent Part Number</b>	<b>Qty</b>	<b>Description</b>
W4	D8064-61601	1	POWER HARNESS CABLE
W5	54810-61617	1	POWER INPUT/LINE SINC
W6	54810-61613	1	CABLE ASSEMBLY POWER SUPPLY
W7	54855-61624	1	MOTHERBOARD SWITCH CABLE
W8	54810-61606	1	AUTOPROBE INTERFACE CABLE
W11	54857-61613	1	DISPLAY CABLE
W12	54826-61601	1	KEYBOARD CABLE
W13	D8104-61603	2	SERIAL ATA CABLE (NOT ON OPTION 017)
W14	54810-61615	1	HARD DRIVE GROUND CABLE (NOT ON OPTION 017)
W17	54810-61604	1	PROBE POWER CABLE
W19	54855-61606	1	FAN CABLE
W20	54801-61626	1	KEYBOARD INTERCONNECT
W21	D8104-61605	1	BACKLIGHT POWER CABLE
W23	54801-61638	2	SMB CABLE BNC TTL & EXT. TRIGGER
W24	54826-61604	1	INTERNAL DIGITAL INPUT CABLE (MSO models)
W25	D8104-61602	1	FRONT PANEL USB CABLE
W26	D8104-61604	1	TOUCHSCREEN CABLE
W27	54857-61613	1	FLAT-PANEL DISPLAY DRIVER CABLE

Block-Level Theory	151
Power Supply Assembly	152
FPD Monitor Assembly	152
Acquisition System	152
Front Panel	152
Disk Drives	152
Attenuators	152
Motherboard	153
Display Board	153
Probe Power and Control	153
Attenuator Theory	155
Acquisition Theory	155
Acquisition Board	155
Acquisition Modes	156
Interface and GPIB Board (A21)	157

Figure 8-1

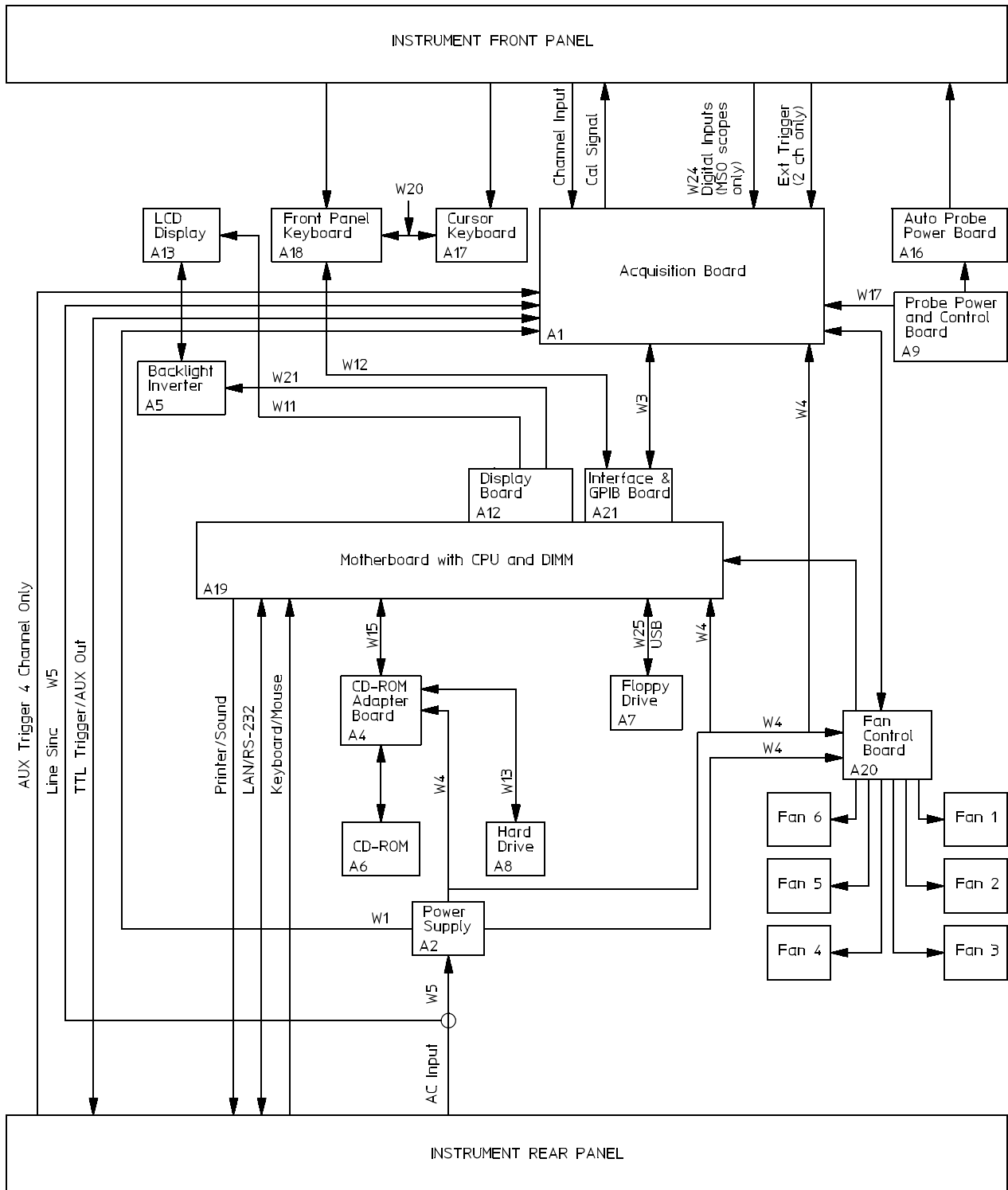

54830612

Oscilloscope Block Diagram

---

# Theory of Operation

This *Service Guide* supports troubleshooting the Agilent Technologies oscilloscopes to assembly level. Theory of operation is included only as supplemental information. It is not comprehensive enough for component-level troubleshooting.

---

## Block-Level Theory

### **The front panel provides:**

- Dedicated knobs and push buttons for major oscilloscope functions.
- An 8.4-inch (diagonal) color flat panel display with touchscreen for waveform display, measurement setup, instrument control, and graphical user interface.
- Front panel USB port.
- BNC connectors for channel input signals.
- AutoProbe interface for probe power and probe control.
- A connection for probe compensation.

### **The rear panel provides several connections:**

- The line power input.
- An GPIB connector, for connection to an oscilloscope controller.
- An RS-232 connection.
- A parallel printer connection.
- XGA monitor connection.
- Mouse and keyboard connections.
- LAN 10/100 connection.
- Auxiliary Input BNC (not on 2 channel oscilloscopes).
- Output BNC.
- TTL trigger output BNC.
- USB Interface.

The oscilloscope has several assemblies and four attenuators. Use the oscilloscope block diagram on the previous page for the following discussion.

### **Power Supply Assembly**

The AC input to the power supply is 100–240 VAC, +/-10%. Maximum input power is 440W. The AC input frequency is 47 to 63 Hz.

Filtered voltages of +5.1 V, -5.2 V, +12.2 V, 3.3 V, and -12.2 V are supplied and distributed throughout the oscilloscope.

### **FPD Monitor Assembly**

The Flat Panel Display (FPD) monitor is a thin film liquid-crystal display (TFT-LCD). This FPD is an 8.4-inch diagonal, 1024 by 768 pixel XGA color monitor. The assembly requires +3.3 V and +12 V from the power supply.

A twin fluorescent back light provides illumination for the LCD. The Backlight Inverter assembly converts the +12 V to +300-1000 volts (acrms) and drives the back light.

### **Acquisition System**

The acquisition system includes four attenuator assemblies on the acquisition board. The attenuators condition the signal, which is then digitized and stored by the acquisition board. The graphics board provides the system control interface from the motherboard, and also interfaces the acquisition board to the display board for display of the acquired data. More detailed theory on the acquisition system follows this top-level block theory.

### **Attenuators**

The attenuators provide the appropriate impedance matching and all the attenuation and gain selection for each input channel. The attenuators are part of the acquisition board.

### **Front Panel**

The front panel is read and controlled by a micro controller IC. This device contains a microprocessor, RAM, ROM, and a DUART for communication with the microprocessor on the main assembly. The micro controller is located on the keyboard and communicates with the system control circuitry through an RS-232 cable. It reads the keys and knobs and controls the LED indicators.

The elastomeric keypad has 30 keys, all dedicated to a single function to improve ease of use. A conductive element on the inside of each key shorts a gap on the underlying keyboard circuit. The keyboard controller detects this short and sends the proper keypress information to the system controller on the motherboard.

There are eleven dedicated knobs. Each knob controls a mechanical encoder. The output of the encoder is a 2-bit gray code that is read by the micro controller for direction and distance turned. A push button controls the power through a Remote Inhibit sense line that is routed to the power supply.

### **Disk Drives**

The hard disk drive is a high-capacity, shock-resistant unit. It is used to store the oscilloscope operating system and certain system configuration data.

The drive can also be used to store and recall oscilloscope setups and waveforms.

### **Motherboard**

The motherboard provides all system control and interface functions for the oscilloscope. It contains a CPU, ROM, and RAM; keyboard and mouse interfaces, serial and parallel interfaces, CDROM, hard disk drive interface, and PCI (Peripheral Component Interconnect) buses.

### **Display Board**

The Display Board controls the flat-panel display monitor. It translates the video signals from the motherboard's on-board video system to the Low Voltage Differential Signal (LVDS) signals that drive the FPD monitor. The display board also provides +12 V to the backlight inverter.

### **Probe Power and Control**

The Probe Power and Control board provides filtered, regulated power to the front-panel AutoProbe interface. It also provides serial communications capability, offset and probe detection and identification circuitry. All of these are interfaced to the probe through the conductive pads surrounding the BNC connectors. Using the facilities of this board, the Autoprobe interface can supply power for active probes, notify the oscilloscope operating system when a probe is connected or disconnected, identify the probe type to the oscilloscope operating system for automatic configuration, and communicate with the probe to support advanced probe functionality.

Figure 8-2

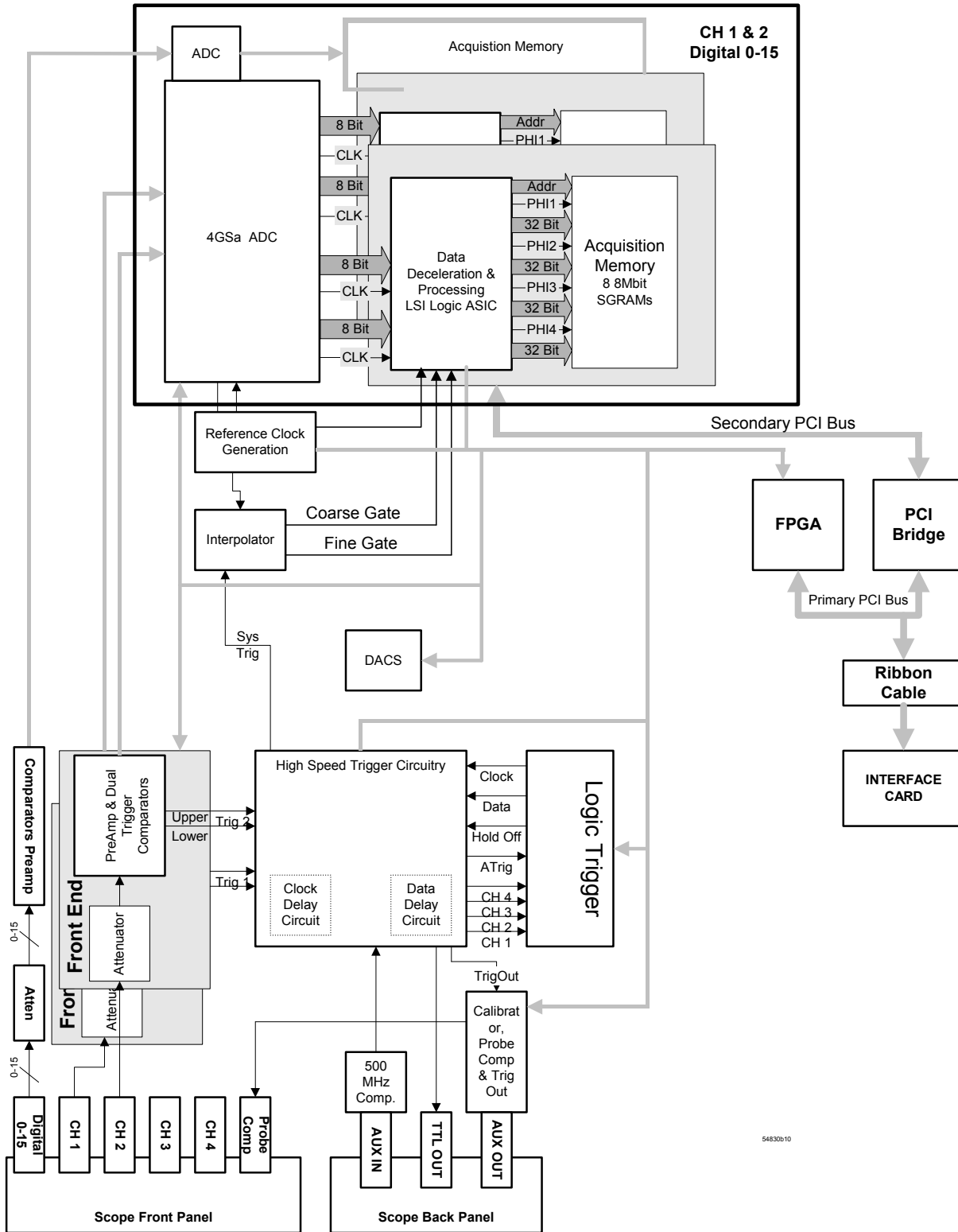

Acquisition Block Diagram

---

## Attenuator Theory

The channel input signals are conditioned by the channel attenuator assemblies. There are four completely independent attenuators on each assembly, but one channel can be routed in the preamp/multiplexer hybrid to drive both channel outputs for sample rate doubling purposes. Each channel contains passive attenuators, an impedance converter, and a programmable gain amplifier. There are two identical outputs for each channel: one to drive the ADC hybrids and one to drive the trigger circuitry.

After the passive attenuators, the signal is split into high-frequency and low-frequency components. Low-frequency components are amplified on the main assembly where they are combined with the offset voltage. The AC coupling is implemented in the low-frequency amplifier.

The high- and low-frequency components of the signal are recombined and applied to the input FET of the impedance converter. The FET provides a high impedance load for the input attenuators and a low impedance drive for a buffer, which drives 50  $\Omega$ .

---

## Acquisition Theory

The acquisition system includes two major sections. One is the acquisition board, which conditions, stores, and processes the input signals. The other is the A1 interface board, which provides the interface from the acquisition to the motherboard and display, and also interfaces the motherboard to the front-panel keyboard.

### Acquisition Board

The acquisition circuitry samples, digitizes, and stores the signals from the channel attenuators. The four channels are identical. The trigger signals synchronize acquisition through the trigger and time base circuitry. A reference oscillator and the time base provide the base sample rates.

**ADC** The Agilent Technologies Infiniium Oscilloscope ADC provides all of the sampling, digitizing, and high-speed waveform storage. Each ADC contains two 2 GSa/s ADCs. They can be run in phase to increase resolution, or out-of-phase to sample at 4 GSa/s. The ADC includes a delay-locked loop to synchronize the sample clock to the 125 MHz timebase reference clock. For sample rates < 2 GSa/s, data is decimated.

**Trigger** There are four main trigger circuits: Trigger Conditioning, Analog Comparators, a Trigger Multiplexer, and Logic Trigger. Trigger signals from the channel are fed to the analog trigger comparators and the trigger conditioning circuit. The trigger conditioning circuitry selects DC, ac, low-frequency reject, high-frequency reject, and noise reject (hysteresis) modes and sets the trigger levels. The trigger multiplexer selects the trigger modes, such as edge, glitch, and pattern trigger.

The channel triggers are sent to the Logic Trigger. The logic trigger provides the advanced triggering functions, such as holdoff, delay, and pattern duration and range. The data delay and clock delay timers are used to implement trigger functions that require timing between 1.5 and 20 ns.

The auxiliary trigger, which cannot be displayed on screen, is compared to the trigger level setting in a separate circuit. The line sync trigger line from the power supply is combined in a multiplexer with the TV trigger and the high frequency reject comparators before being sent to the analog trigger.

**Time Base** The time base provides the sample clocks and timing necessary for data acquisition. It primarily consists of a reference oscillator, time base IC, and trigger interpolator pulse stretcher.

- The 10 MHz oscillator provides the timebase reference.
- The time base has programmable dividers to provide the rest of the sample frequencies appropriate for the time range selected. The time base uses the time-stretched output of the interpolator pulse stretcher to time-reference the sampling to the trigger point. The time base has counters to control how much data is taken after the trigger event (post-trigger data). After enough pre-trigger samples have occurred, the time base IC sends a signal to the trigger multiplexer (ARM) indicating it is ready for the trigger event. When the trigger condition is satisfied, the trigger multiplexer sends a signal back to the time base (SYSTRIG). The time base IC then starts the post-trigger delay counter. When the countdown reaches zero, the sample clocks are stopped and the CPU is signaled that the acquisition is complete.
- The Interpolator Pulse Stretcher is a dual-slope integrator that acts as a time-interval stretcher. When the trigger system receives a signal that meets the programmed triggering requirements (SYSTRIG), it signals the time base. The time base then sends a pulse to the pulse stretcher. The pulse is equal in width to the time between the trigger (SYSTRIG) and the next sample clock. The pulse stretcher stretches this time by a factor of approximately 1000. Meanwhile, the time base hybrid runs a counter with a clock derived from the sample rate oscillator. When the interpolator indicates the stretch is complete, the counter is stopped. The count represents, with high accuracy, the time between the trigger and the first sample clock. The count is stored and used to place the recently acquired data in relationship to the trigger point.

**Calibration** The Calibration circuit provides several signals to the Probe Compensation and Aux Out outputs. Which signal is driven to the front panel depends on the current selection from the drop-down menu in the Calibration dialog box. Available signals for Aux Out include a 715 Hz probe compensation signal, a pulse representing the trigger event, the timebase clock, or a DC voltage in the range -2.5 to +2.5 V. The DC voltage is used for self-calibration, and is an output from a 16-channel DAC. The calibration signals are sent to an analog multiplexer, which selects the signal that will be sent to the front panel.

**Microprocessor Interface** The Microprocessor Interface provides control and interface between the system control and digital functions in the acquisition circuitry.

**Analog Interface** The Analog Interface provides analog control of functions in the acquisition circuitry. It is primarily DACs with accurate references and filtered outputs. The analog interface controls:

- Channel offsets
- Trigger levels
- Two logic trigger functions

### **Acquisition Modes**

The Agilent Technologies oscilloscopes provide two acquisition modes:

- full channel mode
- half channel mode

**Full Channel Mode** In this mode, the oscilloscope uses all the channel inputs.

**Half Channel Mode** In this mode, the oscilloscope only uses the odd channel inputs. The ADC hybrids for the channel 1 inputs are routed to both the channel 1 and channel 2 ADC hybrids. The hybrids are time-aligned to sample 90° out-of-phase to yield a sample rate of 4 GSa/s. Channel 3 and channel 4 are combined in the same way on four channel oscilloscopes.

### **Interface and GPIB Board (A21)**

The Interface Board (A21) has three primary functions:

- Interface the acquisition board to the motherboard system controller.
- Implement miscellaneous oscilloscope functions, including an RS-232 interface to the front-panel keyboard, a 32-bit timer, and non-volatile RAM.
- GPIB remote control interface.

The GPIB Interface provides IEEE-488.2 standard bus services for the oscilloscope. The card interfaces the bus to the motherboard system controller, allowing the system controller to receive and process GPIB commands and return data to the bus. The circuit consists of three main components. The GPIB controller provides an interface between the microprocessor system and the GPIB in accordance with IEEE 488 standards. An 8-bit data buffer and 8-bit control line buffer connect the GPIB controller to the GPIB bus. The GPIB is a 24-conductor shielded cable carrying 8 data lines, 8 control lines, 7 system grounds, and 1 chassis ground.

**Acquisition Board Interface** The interface to the acquisition board consists of 16 data lines, 10 address lines, a R/W line, and read and write strobes. A second read strobe is used for reading acquisition data; the address latches are not used when this strobe is active. Three lines are used to indicate run, trigger, and interpolator status; two control lines are used for trigger control and clocking.

There are two address ranges on the acquisition board; the first is used for reading acquisition data, while the second is used to access status and control elements of the board.

**Miscellaneous System Functions** An RS-232 interface is used to communicate with the front panel keyboard. The connector routes transmit and receive, power supply bias and inhibit signals, and keyboard power to the keyboard. The interface functionality is contained in the FPGA. The data rate is 19.2 KBaud, with 1 start bit, 8 data bits (LSB first), and one stop bit, no parity. The keyboard itself has a controller that transmits and receives data through this interface.

Non-Volatile RAM (NVRAM) on the oscilloscope graphics board provides high-speed access to oscilloscope configuration settings.



## A

accessories, 13, 14  
  supplied, 20, 21  
airflow requirements, 23  
application software, 34  
Autoscale, 33

## B

back panel connections, 24  
BNC connectors, 25, 27

## C

cables  
  power, 139  
  printer, 24  
calibration, 68  
  output, 33  
cautions  
  cleaning, 35  
  disconnecting probes, 27  
  environmental, 17  
  measurement category, 17  
checking the oscilloscope, 20  
cleaning the oscilloscope, 35  
clearance requirements, 23  
configuration  
  default, 33  
connecting  
  GPIB, 24  
  LAN card, 24  
  power, 23  
  printers, 24  
  probes, 25, 27  
contents  
  of oscilloscope package, 20  
controlling the oscilloscope, 24  
cord, power, 139

## D

default setup, 33  
dimensions, 18  
direct mail parts order, 138  
display board, 82

## E

environmental category, 17

## F

feet  
  using, 31

Fluke MET/CAL procedures, 39  
front panel  
  connections, 25, 27

## G

GPIB  
  connecting, 24

## I

inspecting the oscilloscope, 20  
Installing  
  application software, 34  
instrument controller, 24  
instrument options, 15

## L

LAN card, 24

## M

manuals, 20, 21  
measurements, 18  
motherboard, 88  
  ADLINK, 90  
  Intel, 89  
mouse, 24  
  verifying operation, 33

## O

operation  
  verifying, 33  
options available, 15  
oscilloscope  
  cleaning, 35  
  inspecting, 20  
oscilloscope feet, 31  
oscilloscope operation  
  verifying, 33  
oscilloscope probes, see probes

## P

package contents, 20, 21  
packing for return, 97  
parallel printers, 24  
parts  
  direct mail ordering, 138  
pointing device  
  connecting, 24  
  verifying operation, 33  
power  
  applying, 32

connecting, 23  
cords, 139  
requirements, 23  
turning off, 32

printer  
  cables, 24  
  connecting, 24  
probes  
  connecting, 27  
probes available, 14  
probing a circuit, 26

## R

replacing parts, 138  
returning the instrument, 97  
RJ-45 connector, 24  
  LAN card, 24

## S

screen saver, 34  
self-calibration, 68  
setup  
  default, 33  
specifications, 16  
standard accessories, 20, 21  
system settings, 34

## T

tilting the oscilloscope, 31

## V

verifying basic operation, 33  
view angle, changing, 31

## W

Windows system settings, 34

## Y

year of manufacture, 11



# Safety Notices

This apparatus has been designed and tested in accordance with IEC Publication EN 61010-1:2001, Safety Requirements for Measuring Apparatus, and has been supplied in a safe condition. This is a Safety Class I instrument (provided with terminal for protective earthing). Before applying power, verify that the correct safety precautions are taken (see the following warnings). In addition, note the external markings on the instrument that are described under "Safety Symbols."

## Warnings

- Before turning on the instrument, you must connect the protective earth terminal of the instrument to the protective conductor of the (mains) power cord. The mains plug shall only be inserted in a socket outlet provided with a protective earth contact. You must not negate the protective action by using an extension cord (power cable) without a protective conductor (grounding). Grounding one conductor of a two-conductor outlet is not sufficient protection.
- Only fuses with the required rated current, voltage, and specified type (normal blow, time delay, etc.) should be used. Do not use repaired fuses or short-circuited fuseholders. To do so could cause a shock or fire hazard.
- If you energize this instrument by an auto transformer (for voltage reduction or mains isolation), the common terminal must be connected to the earth terminal of the power source.
- Whenever it is likely that the ground protection is impaired, you must make the instrument inoperative and secure it against any unintended operation.
- Service instructions are for trained service personnel. To avoid dangerous electric shock, do not perform any service unless qualified to do so. Do not attempt internal service or adjustment unless another person, capable of rendering first aid and resuscitation, is present.
- Do not install substitute parts or perform any unauthorized modification to the instrument.

- Capacitors inside the instrument may retain a charge even if the instrument is disconnected from its source of supply.

- Do not operate the instrument in the presence of flammable gasses or fumes. Operation of any electrical instrument in such an environment constitutes a definite safety hazard.

- Do not use the instrument in a manner not specified by the manufacturer.

## To clean the instrument

If the instrument requires cleaning: (1) Remove power from the instrument. (2) Clean the external surfaces of the instrument with a soft cloth dampened with a mixture of mild detergent and water. (3) Make sure that the instrument is completely dry before reconnecting it to a power source.

## Safety Symbols



Instruction manual symbol: the product is marked with this symbol when it is necessary for you to refer to the instruction manual in order to protect against damage to the product.



Hazardous voltage symbol.



Earth terminal symbol: Used to indicate a circuit common connected to grounded chassis.

# Notices

© Agilent Technologies, Inc. 2005-2007

No part of this manual may be reproduced in any form or by any means (including electronic storage and retrieval or translation into a foreign language) without prior agreement and written consent from Agilent Technologies, Inc. as governed by United States and international copyright laws.

## Manual Part Number

D8064-97006, September 2007

## Print History

D8064-97000, November 2005  
D8064-97002, February 2006  
D8064-97006, September 2007

Agilent Technologies, Inc.  
1900 Garden of the Gods Road  
Colorado Springs, CO 80907 USA

## Restricted Rights Legend

If software is for use in the performance of a U.S. Government prime contract or subcontract, Software is delivered and licensed as "Commercial computer software" as defined in DFAR 252.227-7014 (June 1995), or as a "commercial item" as defined in FAR 2.101(a) or as "Restricted computer software" as defined in FAR 52.227-19 (June 1987) or any equivalent agency regulation or contract clause. Use, duplication or disclosure of Software is subject to Agilent Technologies' standard commercial license terms, and non-DOD Departments and Agencies of the U.S. Government will receive no greater than Restricted Rights as defined in FAR 52.227-19(c)(1-2) (June 1987). U.S. Government users will receive no greater than Limited Rights as defined in FAR 52.227-14 (June 1987) or DFAR 252.227-7015 (b)(2) (November 1995), as applicable in any technical data.

## Document Warranty

The material contained in this document is provided "as is," and is subject to being changed, without notice, in future editions. Further, to the maximum extent permitted by applicable law, Agilent disclaims all warranties, either express or implied, with regard to this manual and any information contained herein, including but not limited to the implied warranties of merchantability and fitness for a particular purpose. Agilent shall not be liable for errors or for incidental or consequential damages in connection with the furnishing, use, or performance of this document or of any information contained herein. Should Agilent and the user have a separate written agreement with warranty terms covering the material in this document that conflict with these terms, the warranty terms in the separate agreement shall control.

## Technology Licenses

The hardware and/or software described in this document are furnished under a license and may be used or copied only in accordance with the terms of such license.

## WARNING

A **WARNING** notice denotes a hazard. It calls attention to an operating procedure, practice, or the like that, if not correctly performed or adhered to, could result in personal injury or death. Do not proceed beyond a **WARNING** notice until the indicated conditions are fully understood and met.

## CAUTION

A **CAUTION** notice denotes a hazard. It calls attention to an operating procedure, practice, or the like that, if not correctly performed or adhered to, could result in damage to the product or loss of important data. Do not proceed beyond a **CAUTION** notice until the indicated conditions are fully understood and met.