

**INSTRUCTION MANUAL  
MODEL 9200B  
RF MILLIVOLTMETER**

**BOONTON**  
ELECTRONICS CORPORATION

Boonton Electronics Corporation  
25 Eastmans Road, PO Box 465  
Parsippany, NJ 07054-0465

## SAFETY SUMMARY

The following general safety precautions must be observed during all phases of operation and maintenance of this instrument. Failure to comply with these precautions or with specific warnings elsewhere in this manual violates safety standards of design, manufacture, and intended use of the instrument. Boonton Electronics assumes no liability for the customer's failure to comply with these requirements.

### THE INSTRUMENT MUST BE GROUNDED

To minimize shock hazard the instrument chassis and cabinet must be connected to an electrical ground. The instrument is equipped with a three conductor, three prong a.c. power cable. The power cable must either be plugged into an approved three-contact electrical outlet or used with a three-contact to a two-contact adapter with the (green) grounding wire firmly connected to an electrical ground at the power outlet.

### DO NOT OPERATE THE INSTRUMENT IN AN EXPLOSIVE ATMOSPHERE.

Do not operate the instrument in the presence of flammable gases or fumes.

### KEEP AWAY FROM LIVE CIRCUITS.

Operating personnel must not remove instrument covers. Component replacement and internal adjustments must be made by qualified maintenance personnel. Do not replace components with the power cable connected. Under certain conditions dangerous voltages may exist even though the power cable was removed, therefore; always disconnect power and discharge circuits before touching them.

### DO NOT SERVICE OR ADJUST ALONE.

Do not attempt internal service or adjustment unless another person, capable of rendering first aid and resuscitation, is present.

### DO NOT SUBSTITUTE PARTS OR MODIFY INSTRUMENT.

Do not install substitute parts or perform any unauthorized modification of the instrument. Return the instrument to Boonton Electronics for repair to ensure that the safety features are maintained.

### SAFETY SYMBOLS.



This safety requirement symbol (located on the rear panel) has been adopted by the International Electrotechnical Commission, Document 66 (Central Office) 3, Paragraph 5.3, which directs that an instrument be so labeled if, for the correct use of the instrument, it is necessary to refer to the instruction manual. In this case it is recommended that reference be made to the instruction manual when connecting the instrument to the proper power source. Verify that the correct fuse is installed for the power available, and that the switch on the rear panel is set to the applicable operating voltage.



The CAUTION sign denotes a hazard. It calls attention to an operation procedure, practice, or the like, which, if not correctly performed or adhered to, could result in damage to or destruction of part or all of the equipment. Do not proceed beyond a CAUTION sign until the indicated conditions are fully understood and met.



The WARNING sign denotes a hazard. It calls attention to an operation procedure, practice, or the like, which, if not correctly performed or adhered to, could result in injury or loss of life. Do not proceed beyond a WARNING sign until the indicated conditions are fully understood and met.



Indicates dangerous voltages.

## TABLE OF CONTENTS

### SECTION I - GENERAL INFORMATION

Paragraph	Page
1-1 Introduction . . . . .	1-1
1-2 Description . . . . .	1-1
1-4 Application . . . . .	1-2
1-6 Accessories . . . . .	1-2
1-9 Options . . . . .	1-3
1-11 Specifications . . . . .	1-3

### SECTION II - INSTALLATION

2-1 Introduction . . . . .	2-1
2-3 Unpacking . . . . .	2-1
2-5 Mounting . . . . .	2-1
2-7 Power Requirements . . . . .	2-1
2-10 Cable Connections . . . . .	2-1
2-13 Preliminary Checkout Procedure . . . . .	2-2

### SECTION III - OPERATION

3-1 Introduction . . . . .	3-1
3-3 Operating Controls, Indicators, and Connectors . . . . .	3-1
3-5 Operating Instructions . . . . .	3-1
3-7 Initial Conditions . . . . .	3-1
3-9 Programming Measurement Parameters . . . . .	3-1
3-12 Probe Selection . . . . .	3-1
3-14 Use of Numerical Keys . . . . .	3-1
3-16 CLEAR Key . . . . .	3-1
3-18 SELECT Keys . . . . .	3-1
3-20 Probe (Sensor) Select . . . . .	3-5
3-23 PROBE (Sens) Serial Number Recall . . . . .	3-6
3-25 MODE Selection . . . . .	3-6
3-28 REF LEVELS dB Selection . . . . .	3-6
3-32 Select Z <sub>0</sub> . . . . .	3-6
3-34 AVERAGE Function Selection . . . . .	3-6
3-37 X100 key . . . . .	3-7
3-39 Zeroing the Instrument . . . . .	3-7
3-41 Making Measurements . . . . .	3-7
3-43 Recall and Entry of Non-Volatile Memory Data Operation . . . . .	3-7
3-45 Recall and Entry of Instrument Gain Data . . . . .	3-7
3-47 Gain Factor Recall . . . . .	3-8
3-48 Instrument Gain Factory Entry . . . . .	3-8
3-49 Recall and Entry of Probe Data . . . . .	3-8
3-50 Probe (SENS) Serial Number Entry . . . . .	3-8
3-51 Probe Data Recall . . . . .	3-8
3-52 Probe Gain Factor and Gain Correction Entry . . . . .	3-8
3-54 Application Notes . . . . .	3-9
3-55 Overload Limits . . . . .	3-9
3-56 Connection Recommendations . . . . .	3-10
3-57 Low Level Measurements . . . . .	3-10
3-58 Temperature Effects . . . . .	3-10
3-59 Hum, Noise, and Spurious Pickup . . . . .	3-11
3-60 Recorder Output . . . . .	3-11
3-61 Correction Curve for Model 952003 50 Ω N Tee Adapter . . . . .	3-11
3-62 Correction Curve for Model 952007 75 Ω N Tee Adapter . . . . .	3-11

### SECTION IV - THEORY OF OPERATION

4-1 Introduction . . . . .	4-1
4-3 Functional Block Diagram Description . . . . .	4-1
4-10 Detailed Circuit Descriptions . . . . .	4-2
4-11 Probe Circuit . . . . .	4-2
4-14 Input PC Board Circuits . . . . .	4-2
4-23 Control PC Board Circuits . . . . .	4-6
4-30 Display PC Board Circuits . . . . .	4-9
4-36 Power Supply Circuits . . . . .	4-10

## SECTION V - MAINTENANCE

Paragraph	Page	
5-1	Introduction . . . . .	5-1
5-3	Safety Requirements . . . . .	5-1
5-5	Test Equipment Required . . . . .	5-1
5-7	Cleaning Procedure . . . . .	5-1
5-9	Removal and Replacement Procedures . . . . .	5-1
5-10	Instrument Covers . . . . .	5-1
5-11	Non-Volatile RAM Cell Replacement . . . . .	5-1
5-12	Inspection . . . . .	5-3
5-14	Performance Tests . . . . .	5-3
5-16	Preliminary Setup . . . . .	5-3
5-17	Automatic Zero Function Test . . . . .	5-3
5-19	Autoranging Mode Test . . . . .	5-3
5-21	Basic Instrument Accuracy Test . . . . .	5-6
5-23	dB Mode Check . . . . .	5-6
5-25	dB Reference Level Function Test . . . . .	5-6
5-27	Non-Volatile Ram Cell Test . . . . .	5-6
5-29	Probe SWR and Frequency Response Tests . . . . .	5-6
5-31	SWR Tests . . . . .	5-7
5-32	Frequency Response Tests . . . . .	5-7
5-34	Alternate Frequency Response and SWR Test Procedures . . . . .	5-8
5-36	Adjustments . . . . .	5-8
5-37	Power Supply Adjustments . . . . .	5-8
5-39	Input Module Calibration and Adjustments . . . . .	5-9
5-41	DC Calibration . . . . .	5-10
5-43	AC Calibration . . . . .	5-13
5-45	DC Recorder Calibration . . . . .	5-13
5-47	Troubleshooting . . . . .	5-13
5-48	Troubleshooting Concept . . . . .	5-13
5-49	Signature Analysis . . . . .	5-14
5-54	Trouble Localization . . . . .	5-14
5-55	Gaining Access to Internal Components . . . . .	5-14
5-56	Visual Inspection . . . . .	5-14
5-57	Use of Block Diagrams . . . . .	5-14
5-58	Systematic Troubleshooting . . . . .	5-14
5-59	Signature Analysis Free-Running Test Procedures . . . . .	5-19
5-61	Signature Analysis Programmed Test Procedures . . . . .	5-19
5-63	Non-Volatile Ram Circuit Test . . . . .	5-19

## SECTION VI - PARTS LIST

6-1	Introduction . . . . .	6-1
-----	------------------------	-----

## SECTION VII - SCHEMATIC DIAGRAMS

7-1	Table of Contents . . . . .	7-1
-----	-----------------------------	-----

## LIST OF ILLUSTRATIONS

Figure	Page	
1-1	Model 9200B . . . . .	1-7
1-2	Outline Dimensions . . . . .	2-2
2-1	Packing and Unpacking Diagram . . . . .	3-2
3-1	Model 9200B, Front View . . . . .	3-2
3-2	Model 9200B, Rear View . . . . .	3-2
3-3	Attachment of Model 952003 50 Ohm N Tee Adapter to Model 952001A Probe and Model 952014 50 Ohm Termination . . . . .	3-9
3-4	Correction Curves for Models 952003 and 952007 Type N Tee Adapters . . . . .	3-10
4-1	Functional Block Diagram . . . . .	4-1
4-2	Input PC Board Detailed Block Diagram . . . . .	4-3
4-3	Control PC Board Detailed Block Diagram . . . . .	4-7
4-4	Display PC Board Detailed Block Diagram . . . . .	4-11
4-5	Power Supply PC Board Detailed Block Diagram . . . . .	4-13
5-1	Instrument, Top Inside View . . . . .	5-1
5-2	Instrument, Bottom Inside View . . . . .	5-2
5-3	Non-Volatile RAM Cell Test and Connection Points . . . . .	5-7
5-4	RF Probe Frequency Response Test Setup . . . . .	5-8
5-5	Swept Frequency Response Test Setup . . . . .	5-9
5-6	Control PC Board Bit Switch Settings . . . . .	5-11
5-7	Input PC Board, Voltage and Waveform Data . . . . .	5-11

LIST OF TABLES

Table	Page
1-1	Specifications . . . . . 1-4
3-1	Operating Controls, Indicators and Connectors . . . . . 3-3
3-2	Examples of Channel 3 Measurements . . . . . 3-5
5-1	Maintenance Test Equipment . . . . . 5-2
5-2	Control Board Address Field Test . . . . . 5-16
5-3	Control Board Memory Decoding Test . . . . . 5-16
5-4	Control Board I/O Decoding Test . . . . . 5-17
5-5	Control Board ROM 0 Test . . . . . 5-17
5-6	Control Board ROM 1 Test . . . . . 5-17
5-7	Control Board 4A810 Test . . . . . 5-18
5-8	Control Board 4C10 Test . . . . . 5-19
5-9	Control Board 4D10 Test . . . . . 5-19
5-10	Display Visual Test . . . . . 5-20
5-11	Control Board Display Test . . . . . 5-20
5-12	Control Board Display Scan Test . . . . . 5-20
5-13	Keyboard Visual Test . . . . . 5-21
5-14	Control Board RAM Test . . . . . 5-21
5-15	Input Module Channel 1 0A10 Test . . . . . 5-22
5-16	Input Module Channel 1 0B10 Test . . . . . 5-22
5-17	Input Module Channel 1 0C10 Test . . . . . 5-23
5-18	Input Module Channel 1 0D10 Test . . . . . 5-23
5-19	Input Module Channel 2 1C10 Test . . . . . 5-24
5-20	Input Module Channel 2 1D10 Test . . . . . 5-24
6-1	Manufacturers Code Numbers . . . . . 6-1
6-2	Replaceable Parts . . . . . 6-2

APPENDIX A - IEEE-488 BUS INTERFACE OPTION 9200B-01B

Paragraph	Page
A-1	Description . . . . . A-1
A-4	Capability . . . . . A-1
A-6	Installation . . . . . A-1
A-8	Operation . . . . . A-1
A-9	Address Assignment . . . . . A-1
A-10	Message Terminator . . . . . A-1
A-11	Command Response . . . . . A-1
A-12	Operating States . . . . . A-2
A-13	Remote Programming . . . . . A-4
A-14	Bus Programming Syntax . . . . . A-4
A-19	Store/Recall Functions Syntax . . . . . A-5
A-21	Output Data Format . . . . . A-5
A-22	Hold Measurement Function Syntax . . . . . A-5
A-23	SRQ Function Syntax . . . . . A-5
A-24	Measurement Trigger Syntax . . . . . A-5
A-25	Typical Application . . . . . A-5
A-27	Use of Hold Measurement, Pull SRQ and Trigger Commands . . . . . A-6
A-30	Sealed System Operation . . . . . A-7
A-31	Theory of Operation . . . . . A-7
A-32	General . . . . . A-7
A-33	Detailed Description . . . . . A-7
A-38	Maintenance . . . . . A-9
A-39	General . . . . . A-9
A-40	Physical Inspection . . . . . A-9
A-41	Voltage Checks . . . . . A-9
A-42	Active-Device Substitution . . . . . A-9
A-43	Troubleshooting . . . . . A-9
A-44	Replaceable Parts . . . . . A-9
A-46	Schematics . . . . . A-9

APPENDIX B - INPUT CHANNEL 2 OPTION 9200A-03

Paragraph	Page
B-1	Description . . . . . B-1
B-3	Installation . . . . . B-1
B-5	Operation . . . . . B-1
B-9	Maintenance . . . . . B-1

APPENDIX C - MATE OPTION 9200B-06

Paragraph	Page
C-1 Description . . . . .	C-1
C-4 Mate Configuration . . . . .	C-1
C-8 Operation . . . . .	C-1
C-12 SETUP . . . . .	C-2
C-18 CLOSURE . . . . .	C-2
C-22 INITIATION . . . . .	C-2
C-28 RESULT FETCH . . . . .	C-3
C-33 DISCONNECT . . . . .	C-3
C-38 RESET . . . . .	C-3
C-43 SELF TEST . . . . .	C-3
C-47 STATUS COMMAND . . . . .	C-3
C-52 SOFTWARE CODES . . . . .	C-4
C-54 Maintenance . . . . .	C-4



Figure 1-1. Model 9200B RF Millivoltmeter.

SECTION I  
GENERAL INFORMATION

## 1-1. INTRODUCTION

This instruction manual provides general information, installation and operating instructions, theory of operation, maintenance instructions, and parts list for the Model 9200B RF Millivoltmeter.

## 1-2. DESCRIPTION

The Model 9200B is a microprocessor-based RF Millivoltmeter that is capable of measuring RF voltage levels from 200 microvolts to 3 volts over a frequency range from 10 kHz to 1.2 GHz.

The measured RF levels can be displayed directly in mV, dBV, dBmV, dBm (dB relative to 1 mW across any impedance between 5  $\Omega$  and 2506  $\Omega$ ) or dBW (dB relative to 1W across any impedance between 20  $\Omega$  and 2000  $\Omega$ ).

## 1-3. The instrument design features are:

a. Wide Frequency Range. The calibrated frequency range of the instrument is determined by the probe used with the instrument. The 952001A RF Probe supplied with the instrument provides calibrated indications from 10 kHz to 1.2 GHz, with uncalibrated response to beyond 8 GHz. An optional 952009 RF Sensor provides calibrated, 50  $\Omega$  terminated indications from 100 kHz to 2.5 GHz. The optional 952016 RF probe provides calibrated response from 10 Hz to 100 MHz.

b. Sensitivity and range linearization data for the probe supplied with the instrument is stored in non-volatile memory. If another probe is used with the instrument, data for this probe must be entered into non-volatile memory before using the probe. Data entry is a simple procedure, requiring only operation of an internal switch and entry of data through the front panel keys. No further calibration is necessary.

c. Voltage Range. The instrument has eight voltage measurement ranges from 1 mV to 3 volts full scale, arranged in a 1-3-10 sequence. In the dB measurement modes, it covers a range of 80 dB in 8 ranges, with 0.01 dB resolution. The measurement capability of the instrument can be extended to 300 volts at frequencies up to 700 MHz when the optional 952005 100:1 Voltage Divider is used and 300 volts for frequencies between 10 Hz and 20 MHz when the optional 952058 100:1 Voltage Divider is used.

d. True RMS Response. Waveform response of the instrument probe is true RMS for inputs below 30 mV, allowing accurate voltage measurements with all types of waveforms. Probe waveform response changes gradually as the input voltage is raised above 30 mV approaching peak-to-peak at the higher levels. The instrument shapes the response digitally to indicate RMS voltage, provided that the input is reasonably sinusoidal, as with CW or FM input signals.

e. Low Noise. The instrument has been designed and constructed to minimize noise from all sources. The probe cable is of a special low noise design; vigorous flexing causes only momentary, minor deflections on the most sensitive range of the instrument. The probes are insensitive to shock and vibration; even sharp tapping on the probe barrel causes no visible deflection on any range. Internal signal amplification occurs at approximately 94 Hz, thereby reducing susceptibility to 50 or 60 Hz fields. A low noise solid-state chopper is used.

f. Key Selection of Measurement Modes. A choice of measurement modes is available to the operator. Measurements in terms of mV, dBV, dBmV, dBm (dB relative to 1 mW across any impedance between 5  $\Omega$ s and 2500  $\Omega$ s) or dBW (dB relative to 1W across any impedance between 20  $\Omega$ s and 2000  $\Omega$ s) can be selected by merely pressing the appropriate front panel key. The keyboard also allows entry of dB reference levels and impedance values for these measurement modes.

g. Measured values are displayed on a 4 digit LED type readout with decimal points and minus sign. Annunciators associated with the display indicate the units of measurement. The result is clear, direct, unambiguous readout that minimizes the possibility of misinterpretation. The display is also used to show data being entered into non-volatile memory and to display data recalled from non-volatile memory. The display and annunciators blink on and off during data entry and recall to indicate that displayed values are not measured values.

h. A front panel meter provides relative RF level indications for peaking or nulling applications. A rear panel DC output supplies 10 volts full scale that is linear with voltage in the mV mode, or linear in dB over the entire 80 dB range in any of the dB modes.

i. Autoranging under control of the microprocessor eliminates the need for manual ranging by the operator. Alternately, a measurement range can be retained for measurements, if desired, by selecting a range hold mode through the IEEE-488 Bus when the instrument is so equipped. Application of input levels beyond the measurement capability of the instrument in the autorange mode or outside the selected range in the range hold mode results in an error indication on the display.

j. An automatic zeroing circuit eliminates the need for tedious, often inaccurate manual zeroing. With zero input to the probe, pressing the front panel ZERO key causes the microprocessor to compute and store zero corrections for each range, which are applied to subsequent readings. A logic transition is available at a rear panel connector for automatic turn off of a source during the automatic zeroing sequence.

## SECTION I GENERAL INFORMATION

k. Sensitivity and range linearization data for up to eight probes may be stored in the instrument non-volatile memory. Probe data is written into memory at the factory for probes ordered with the instrument. Probe data may also be written into memory quickly and easily in the field. A hard copy of stored data is provided under the top cover of the instrument. The microprocessor corrects measurements automatically in accordance with the stored probe data.

l. High/Low dB Limits. High and low dB limits can be entered through the IEEE-488 Bus when the instrument is so equipped. Rear panel TTL outputs provide remote indications of out-of-limit conditions.

m. Solid-state Chopper. Signal amplification in the instrument occurs at approximately 94 Hz. Input signals from the probe are converted into 94 Hz signals by a solid-state, low-level input modulator (chopper).

n. The instrument is designed for easy maintenance. Accessibility to all printed circuit boards is excellent. Connection facilities for signature analysis are incorporated and special diagnostic ROMs are available. Digital circuit troubles can be localized rapidly and accurately using the signature-analysis maintenance technique, thereby reducing instrument downtime.

o. GPIB Option. A full function GPIB can be installed in the 9200B. This interface allows remote operation of all front panel controls, except the line switch. Individual voltage and dB ranges may be selected and selectively zeroed. Listen/talk address and message termination characters are set by a rear panel bit switch.

p. MATE Option. An internal TMA is available that allows the 9200B to respond to CILL commands.

### 1-4. APPLICATION

1-5. The instrument can be used for the following applications:

a. Measurement of transistor parameters.

b. SWR and return loss measurements with directional couplers, reflection coefficient bridges and slotted lines.

c. Gain and loss measurements of wide-band amplifiers.

d. Adjustment of tuned circuits in narrow-band amplifiers.

e. Adjustment, performance measurements and parameter evaluation of RF filters.

f. Measurement of SWR, return loss and attenuation of RF attenuators.

g. Measurement of output levels of signal generators, adjustment of baluns, harmonic distortion measurements of RF signals and adjustment of RF circuits for minimum voltage (null) or maximum voltage (peak).

### 1-6. ACCESSORIES

1-7. The following accessories are supplied with the instrument:

a. 41-2A Sensor/Probe Interconnecting Cable (5 ft.) (M/M).

b. 952001A RF Probe. Probe with low-noise cable and connector assembly for measurements from 10 kHz to 1.2 GHz. Refer to Table 1-1 for input resistance and capacitance.

c. 952002 50  $\Omega$  BNC Adapter. Used for measurements up to 1.2 GHz in a 50  $\Omega$  system.

d. 952004 Probe Tip. Removable probe tip with grounding-clip lead; for use up to approximately 100 MHz.

e. 952005 100:1 Voltage Divider. Attenuates input signal by a factor of  $100 \pm (1 + f_{MHz}/200)\%$ , permitting measurements up to 300 V, and extending the rms measuring range to 3 V; also increases input resistance by a factor of 1000 to 3000, depending upon input level. Operates from 50 kHz to 700 MHz. Maximum input potential, 1000 VDC plus peak AC.

1-8. The following accessories are optional and may be ordered:

a. 41-2A/10 Sensor/Probe Interconnecting Cable (10 ft.) (M/M).

b. 41-2A/20 Sensor/Probe Interconnecting Cable (20 ft.) (M/M).

c. 41-2A/50 Sensor/Probe Interconnecting Cable (50 ft.) (M/M).

d. 41-2A/100 Sensor/Probe Interconnecting Cable (100 ft.) (M/M).

e. 950000 Rack Mtg. Kit, Single. Mounts one unit left or right of blank panel in 19 inch rack. 5.25 inches high.

f. 950001 Rack Mtg. Kit, Dual. Mounts two units side by side in 19 inch rack. 5.25 inches high.

g. 950002 Single Rack Mounting Kit. Kit for mounting one 9200B as one-half of a module in a standard 19-inch rack.

h. 950029 Transit Case.

i. 952003 50  $\Omega$  Tee Adapter. Type N Tee connector used with 952014 termination, it permits connection into a 50 ohm line.

j. 952006 75  $\Omega$  BNC Adapter. Used for measurements up to 500 MHz in a 75 ohm system.

k. 952007 75  $\Omega$  Tee Adapter. Type-N Tee connector; used with 952015 termination it permits connection into a 75 ohm line.

l. 952008 Unterminated BNC Adapter (Female). Used for coaxial connection up to approximately 100 MHz, or to 400 MHz when fed from a 50 ohm source in an electrically short system.

SECTION I  
GENERAL INFORMATION

1-8. (Continued)

- m. 952009 50  $\Omega$  Sensor. 50  $\Omega$  terminated sensor for voltage and power measurements, 100 kHz to 2.5 GHz.
- n. 952011-2 50  $\Omega$  Accessory Kit. For Model 952001A Probe. Consist of Models 952003, 952005, 952008, 952013, and Model 952014 50  $\Omega$  Type N Male Termination.
- o. 952012-2 75  $\Omega$  Accessory Kit. For Model 952000 Probe. Consist of Models 952005, 952007, 952008, 952013, and Model 952015 75  $\Omega$  Type N Male Termination.
- p. 952013 Accessory Case. For use with the 952001A probe and accessories.
- q. 952016 Low Frequency Probe. 10 Hz to 100 MHz. Overload protection, 10 VAC and 50 VDC.
- r. 952058 100:1 Divider. For use with 952016 Low Frequency Probe; frequency range 10 Hz to 20 MHz.

1-9. OPTIONS

1-10. The following options are available:

- a. -01B IEEE 488 Bus Interface. Duplicates all front panel functions except on/off power switch. In addition individual voltage and dB ranges may be selected and selectively zeroed.
- b. -03 Input Channel 2. Allows display of either channel 1 or channel 2, or channel 3 which is channel 1 minus channel 2, expressed in dB. Includes second 952004 Probe Tip and 952002 50  $\Omega$  BNC Adapter.
- c. -06 MATE. Internal TMA. Requires -01B Option.
- d. -11 Low Frequency Version. Includes the 952016 Low frequency Probe, 952002 50  $\Omega$  BNC Adapter, 952008 unterminated BNC Adapter, and the 952058 100:1 Divider.
- e. -12 Dual Channel Low Frequency Version. Includes two 952016 Low frequency Probes, two 952002 50  $\Omega$  BNC Adapters, two 952008 unterminated BNC Adapters, and two 952058 100:1 Dividers.

1-11. SPECIFICATIONS

1-12. Specifications are listed in Table 1-1.

SECTION I  
GENERAL INFORMATION

TABLE 1-1. SPECIFICATIONS

**VOLTAGE RANGE:** 200  $\mu$ V to 3V in 8 ranges (300 V to 700 MHz with Divider).  
Indications down to 50  $\mu$ V.

**VOLTAGE DISPLAY:** 1,000, 3,000, 10,00, 30,00, 100,0, 300,0, 1000 and 3000 mV fs.

**dB RANGE:** 80 dB in 8 ranges, 0.01 dB resolution.

**dB DISPLAY:** dBmV (0 dB equivalent to 1 mV), dBV (0 dB equivalent to 1 V), dBm (0 dB equivalent to voltage drop generated when 1 mW is dissipated in selectable  $Z_0$  reference), dB $r$  (0 dB equivalent to any desired dB reference level) or dBw (dB relative to 1W across any impedance between 20  $\Omega$  and 2000  $\Omega$ ).

**$Z_0$  Impedance:** Any value from 20 to 2000  $\Omega$ .

**Reference dB Offset:** Any offset can be keyboard selected to 0.01 dB resolution provided that the available display range of  $\pm 99.99$  dB is not exceeded.

**RANGING:** Autoranging, plus hold-on-range. Individual ranges may be commanded via bus interface option.

**FREQUENCY RANGE:** 10 kHz to 1.2 GHz, Model 952001A Probe; 100 kHz to 2.5 GHz, optional Model 952009 Sensor. 10 Hz to 100 MHz when the optional Model 952016 Probe is used.

**WAVEFORM RESPONSE:** RMS to 30 mV, calibrated in rms of a sinewave above 30 mV (RMS to 3 V and 700 MHz with Divider).

**CREST FACTOR:**

Direct Input:	Level	300 $\mu$ V	1 mV	3 mV	10 mV	30 mV
	C.F.	140	42	14	4.2	1.4
With Divider:	Level	30 mV	100 mV	300 mV	1 V	3 V
	C.F.	140	42	14	4.2	1.4

**INPUT CONFIGURATION:**

**Probe:** Model 952001A, button center conductor, 1/2-20 threaded ground shell (supplied).

**Probe Tip:** For Model 952001A, probe, needle tip, ground clip lead, Model 952004 (supplied).

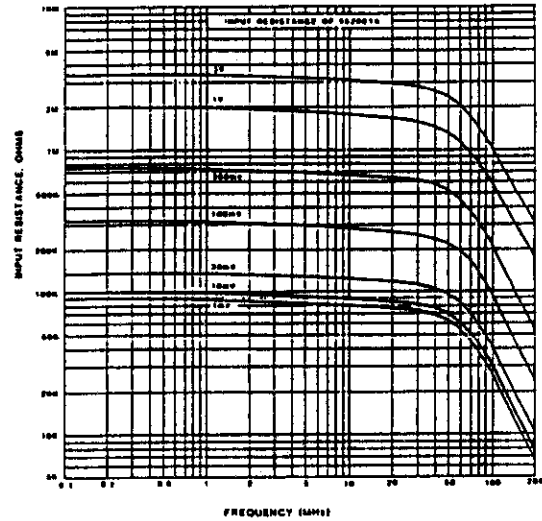

83181300A

INPUT RESISTANCE VS, FREQUENCY,  
MODEL 952001A

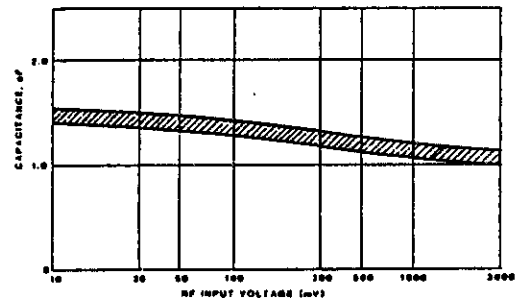

INPUT CAPACITANCE VS, INPUT VOLTAGE,  
MODEL 952001A RF PROBE

**Adapter:** Model 952002 50  $\Omega$  terminated BNC female, for use with the Model 952001A Probe. (Supplied).

**Input Impedance:** Refer to the graphs.

**MAXIMUM AC INPUT:** 10 V, all frequencies and ranges.

**MAXIMUM DC INPUT:** 200 V, all ranges.

**RECORDER OUTPUT:** 10 V fs proportional to indicated voltage (voltage mode) over each range; 8 V equivalent to 0 dBm regardless of  $Z_0$  (dB modes) with a sensitivity of 1 V per 10 dB change over the entire range.

**ACCURACY:** The maximum uncertainty is the sum of the uncertainties listed in sections A, B and C.

TABLE 1-1. SPECIFICATIONS (CONT.)

A. Basic Uncertainty:

Voltage Level	mV	dBV, dBmV, dBm
3 mV - 3000 mV	1% rdg = 1 count	see curve
1 mV - 3 mV	2% rdg = 2 counts	
0.2 mV - 1 mV	3% rdg = 3 counts	

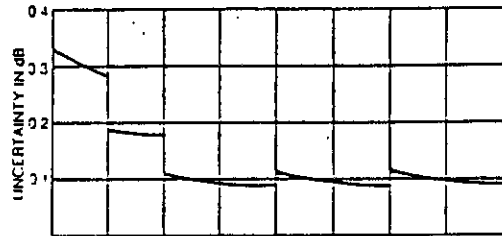

dBV	-10	0	10	20	30	40	50	60	70
dBm	-70	-60	-50	-40	-30	-20	-10	0	10
dBm	-57	-47	-37	-27	-17	-7	3	13	23

MODEL 9200B UNCERTAINTY VS. INPUT LEVEL  
FOR dBV, dBmV, AND dBm.

B. Frequency Effect:

Model 952001A Probe with Model 952002 50  $\Omega$   
BNC Adapter or Model 952003 Tee Adapter.

Frequency	mV	dBV, dBmV, dBm
1 MHz (cal freq)	0	0
10 kHz - 100 MHz	1% rdg	0.09 dB
100 MHz - 1 GHz	3% rdg	0.27 dB
1 GHz - 1.2 GHz	7% rdg	0.63 dB

Model 952003 Tee Adapter  
1.2 GHz - 2.0 GHz 7%  $\pm$  0.01%/mV

SWR: 1.05 to 300 MHz, 1.10 to 1 GHz,  
1.15 to 1.2 GHz

Model 952009 Terminated Voltage Sensor.

Frequency	mV	dBV, dBmV, dBm
1 MHz (cal freq)	0	0
100 kHz - 1 GHz	1% rdg	0.09 dB
1 GHz - 2 GHz	3% rdg	0.27 dB
2 GHz - 2.5 GHz	5% rdg	0.45 dB

SWR: 1.05 to 2 GHz, 1.10 to 2.5 GHz,

Model 952016 Low Frequency Probe with Model  
952002 BNC Adapter.

Frequency	mV	dBV, dBmV, dBm
1 MHz (cal freq)	0	0
50 Hz - 20 MHz	1% rdg	0.09 dB
20 Hz - 50 Hz	2% rdg	0.17 dB
10 Hz - 100 MHz	5% rdg	0.45 dB

SWR: 1.05 to 100 MHz.

Model 952016 Low Frequency Probe with Model  
952058 100:1 Divider.

Frequency	mV	dBV, dBmV, dBm
1 MHz (cal freq)	0	0
1 MHz - 20 MHz	5% rdg	0.45 dB
50 Hz - 1 MHz	3.5% rdg	0.31 dB
20 Hz - 50 Hz	4.5% rdg	0.40 dB
10 Hz - 20 Hz	7.5% rdg	0.68 dB

Model 952001A Probe with Model 952006 75  $\Omega$   
BNC Adapter.

Frequency	mV	dBV, dBmV, dBm
1 MHz (cal freq)	0	0
10 kHz - 100 MHz	1% rdg	0.09 dB
100 MHz - 300 MHz	3% rdg	0.27 dB
300 MHz - 500 MHz	6% rdg	0.54 dB

SWR: 1.05 to 150 MHz, 1.10 to 300 MHz,  
1.20 to 500 MHz

Model 952001A Probe with Model 952007 75  $\Omega$   
Tee Adapter.

Frequency	mV	dBV, dBmV, dBm
1 MHz (cal freq)	0	0
10 kHz - 100 MHz	1% rdg	0.09 dB
100 MHz - 700 MHz	3% rdg	0.27 dB
700 MHz - 1 GHz	7% rdg	0.63 dB

SWR: 1.05 to 150 MHz, 1.10 to 750 MHz,  
1.25 to 1 GHz

SECTION I  
GENERAL INFORMATION

TABLE 1-1. SPECIFICATIONS (CONT.)

C. Temperature Effect:  
Model 952001A Probe or Model 952009 Sensor  
at 10 kHz to 1.2 GHz.

Temp	mV		dBV, dBmV, dBm	
	Inst	Probe/ Sensor	Inst	Probe/ Sensor
21°C - 25°C	0	0	0	0
18°C - 30°C	0	1% rdg	0	0.09 dB
10°C - 40°C	1% rdg	3% rdg	0.09 dB	0.26 dB
0°C - 55°C	2% rdg	7% rdg	0.18 dB	0.63 dB

**LINE STABILITY:** Less than 0.2% rdg with  $\pm 10\%$  line voltage change at reference line conditions of 115 to 120 V, 50 to 400 Hz. Usable after 5 min. warmup.

**ZERO:** Automatic, operated by panel key switch.

**DISPLAY:** 4 digit LED display of voltage or dB. Auxiliary analog display, uncalibrated, proportional to voltage (voltage mode) or dB (dB modes).

**ANNUNCIATORS:** LEDs indicate V, mV, dBV, dBmV, dBm, dBw, dBc and X100. Also shows use of channel 1 (CH1), channel 2 (CH2) or channel 3 (CH3) with option -03 where CH3=CH1-CH2 in dB. Indicate IEEE-488 bus activity (LSN, ATN, REM and TLK) with option -01B.

**ENVIRONMENTAL PERFORMANCE:**  
Operating Temperature: 0° C to +55° C.

Storage Temperature: -55° C to +75° C.

**Classification:** Conforms to the requirements of Mil-T28800C for Type II, Class 5, Style E equipment.

**POWER:** 100, 120, 220, 240 V  $\pm 10\%$ , 50-400 Hz; 24 VA.

**WEIGHT:** 10 lbs. (4.54 kg) approx.

**DIMENSIONS:** 5.85 in (14.9 cm) high, 8.3 in (21.1 cm) wide, and 12.27 in (30.1 cm) deep.

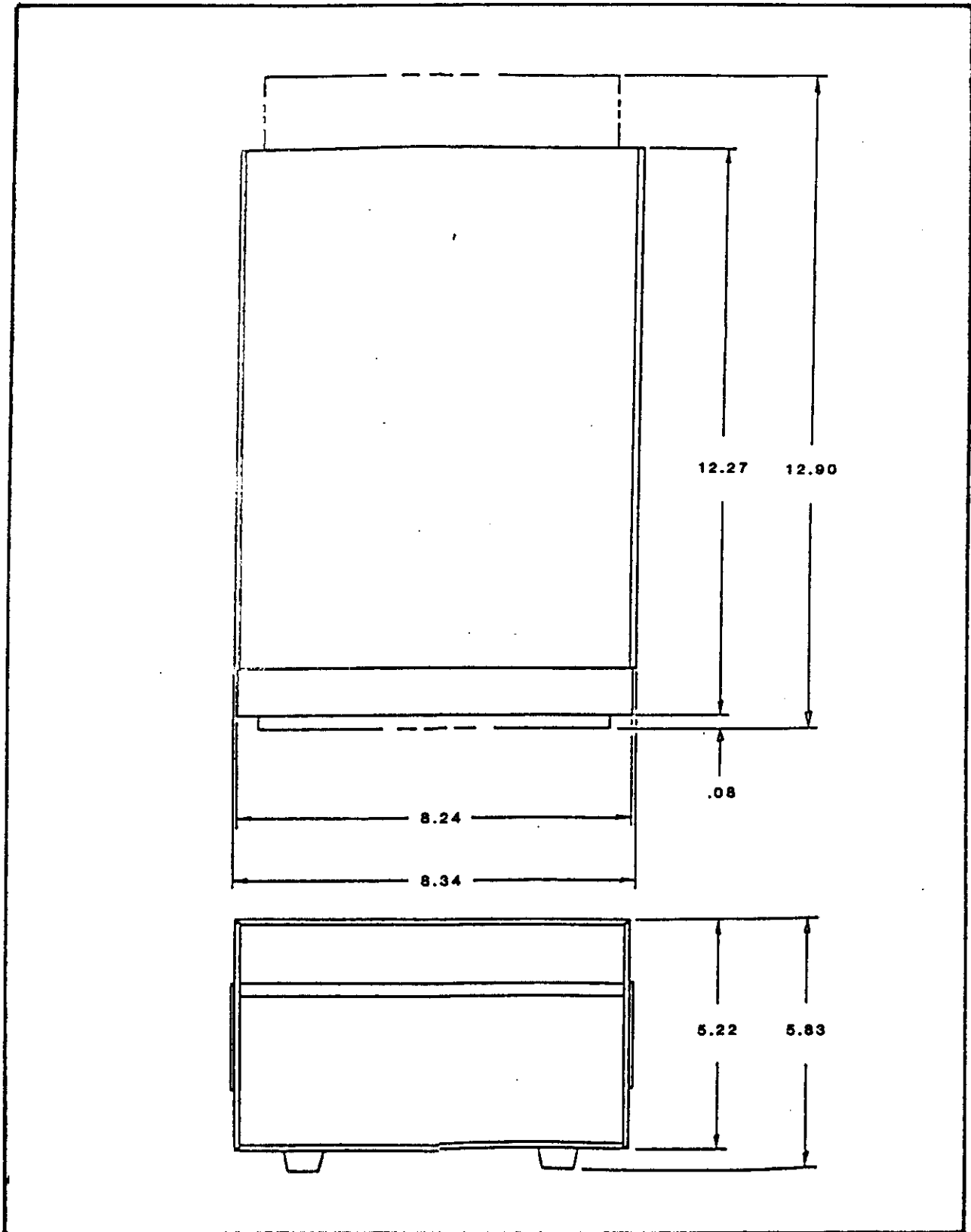

Figure 1-2. Outline Dimensions.

SECTION 11  
INSTALLATION

2-1. INTRODUCTION

2-2. This section contains the installation instructions for the Model 9200B RF Millivoltmeter and includes the unpacking, mounting, power requirements, power fail protection, cable connections, and the preliminary checkout procedure.

2-3. UNPACKING

2-4. The instrument is shipped complete and is ready to use upon receipt. Unpack the instrument from its shipping container and inspect it for damage that may have occurred during shipment. Refer to Figure 2-1.

NOTE

Save the packing material and container for possible use in reshipment of the instrument.

2-5. MOUNTING

2-6. For bench mounting, choose a clean, sturdy, uncluttered mounting surface. For rack mounting, an accessory kit is provided with the instrument that provides mounting ears and rear supports. The rack mounting kit contains the required hardware and instructions.

2-7. POWER REQUIREMENTS

2-8. The instrument has a tapped power transformer and two line voltage selection switches which permit operation from 100, 120, 220 and 240 volt  $\pm 10\%$ , 50 to 60 Hz, single phase AC power sources. Power consumption is approximately 100 VA.

CAUTION

Always make certain that the line voltage selector switches are set to the correct positions most nearly corresponding to the voltage of the available AC power source, and that a fuse of the correct rating is installed in the fuse holder before connecting the instrument to any AC power source.

2-9. Set the line voltage selector switches, located on the rear panel to the appropriate positions as indicated on the LINE VOLTAGE SELECT chart located next to the switches. Check that the line fuse is correct for the selected power source.

VOLTAGE	FUSE
100/120 V	0.3 A MDL (SB)
220/240 V	0.2 A MDL (SB)

2-10. CABLE CONNECTIONS

2-11. Cable connections required depend on the use and what options are installed. A line cord and voltage probe are supplied with the instrument, a second voltage probe is supplied with option 9200B-03. Any other cables required must be supplied by the user.

2-12. Cable connections that may be required are as follows:

a. PROBE CHNL 1 Input. Front panel connector that provides a means for connecting probe to the instrument channel 1 input.

b. J1 IEEE-488 Bus connector. Rear panel connector that provides a means for connecting to the IEEE-488 Bus interconnection when the 9200B-01B option is installed.

c. P3 Status Output connector. Rear panel connector that provides signal outputs for input disconnect during zeroing operations and high and low dB limit signals. Pin connections are as follows:

Connector Pin	Signal
1	Common
2	Not used
3	Logic high indicates zeroing operation.
4	Logic low if measured value is within dB limits; logic high if measured value is above high dB limit.
5	Logic low if measured value is within dB limits; logic high if measured value is below low dB limit.

d. RECORDER Output connector. Rear panel RECORDER connector (type BNC) provides an analog DC voltage that is linear with voltage over each decade range in the mV measurement mode, or linear in dB over the entire 80 dB range in any of the dB modes. Output impedance is approximately 9000 ohms. Maximum current capability is 1 milliampere into 1000 ohms. Full scale DC voltage for each range in the mV mode is 10 volts. Output voltage in all dB modes is as follows:

Measured dBV	Output Voltage
+10	10 volts
0	9 volts
-10	8 volts
-20	7 volts
-30	6 volts
-40	5 volts
-50	4 volts
-60	3 volts
-70	2 volts

e. CHNL1 and CHNL 2 Input connectors. Rear panel connectors that provide a means for connecting probes to instrument CHNL 1 or CHNL 2, when the 9200B-03 or 9200B-12 options are installed.

2-13. PRELIMINARY CHECKOUT PROCEDURE

2-14. The preliminary check verifies that the instrument is operational and should be performed before the instrument is placed into use. Refer to Section V for the Performance Tests.

**SECTION 11  
INSTALLATION**

2-15. Perform the preliminary checkout as follows:

- a. Connect the power cord to the instrument and the desired power source. Refer to paragraph 2-7 for proper power application.
- b. Set the LINE switch to ON.
- c. Check operation of the LED display and the numerical keys by pressing the following keys in the sequence indicated and noting the LED display:

Press	Display	Press	Display
CLR	0000	5	0045
●	0000.	6	0456
0	000.0	7	4567
1	00.01	CLR	0000
2	0.012	8	0008
3	0123	9	0089
CLR	0000	CHS	-0089
4	0004		

d. Connect the probe that is marked Channel 1 to the front panel PROBE CHNL 1 input connector.

e. Enter measurement parameters by pressing the following keys:

- 1 SELECT CHNL
- 0 REF LEVEL dB
- MODE dBm
- 50 SELECT Z<sub>0</sub>

f. Check to see that the dBm and CH1 annunciators are lighted.

g. With zero input to the probe, press the ZERO key. The instrument will go through an automatic zeroing cycle. During the zeroing cycle the display will show cccc; in approximately 18 seconds, the display will return and show cc 3, indicating that zeroing is complete and the input level is underrange.

**NOTE**

The 9200B will display eight error codes, as follows:

- cc 1 Entry too small
- cc 2 Entry too large
- cc 3 Measurement underrange
- cc 4 Measurement overrange
- cc 5 Zero acquisition out of range - excessive negative offset (hardware malfunction, e.g., input connector polarity reversed, or negative chopper offset).
- cc 6 Zero acquisition out of range - excessive positive offset (input too large).
- cc 7 Channel 3 over/underrange
- cc 8 Probe (sensor) serial number is not in instrument's memory.

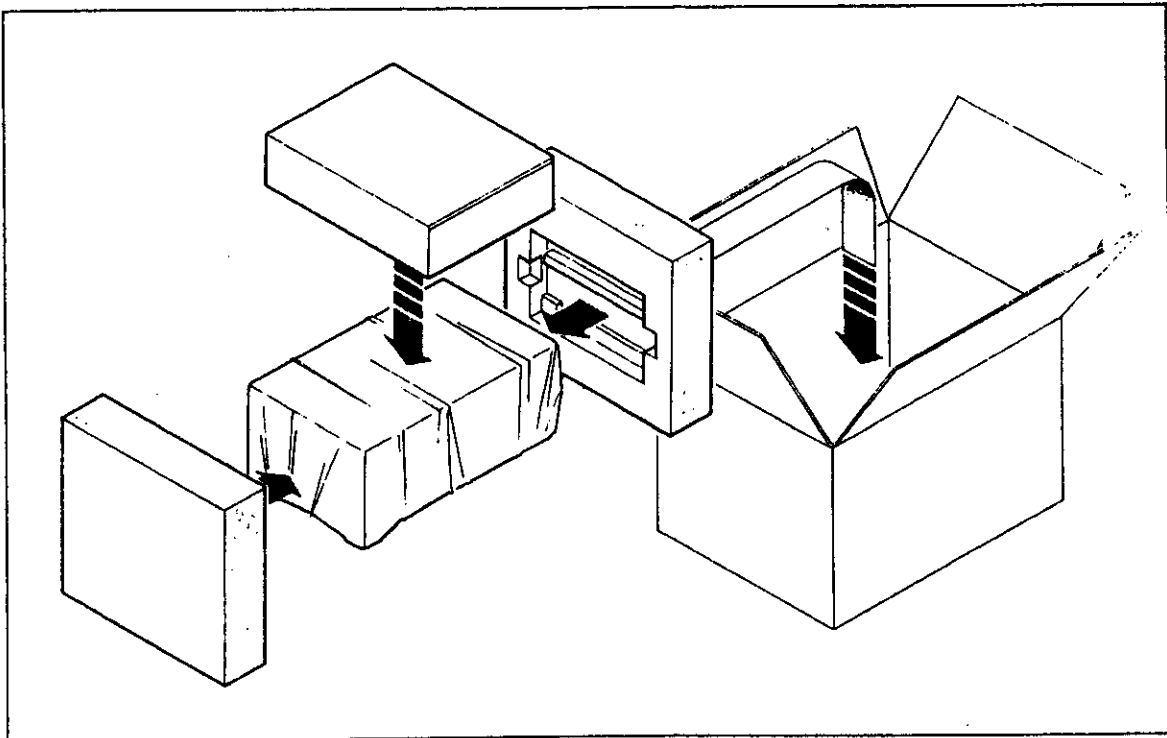

Figure 2-1. Packing and Unpacking Diagram.

SECTION III  
OPERATION

## 3-1. INTRODUCTION

3-2. Section III contains the operating controls, indicators, and connectors descriptions and functions, initial conditions, and operating instructions for the instrument.

## 3-3. OPERATING CONTROLS, INDICATORS, AND CONNECTORS

3-4. The controls, indicators, and connectors used during operation of the instrument are listed in Table 3-1 and shown in Figures 3-1 and 3-2.

## 3-5. OPERATING INSTRUCTIONS

3-6. The operating instructions for the instrument are as follows:

- a. Initial conditions.
- b. Programming Measurement Parameters.
- c. Zeroing the instrument.
- d. Making Measurements.
- e. Recall and Entry of Instrument Non-Volatile Memory Data Operations.
- f. Application Notes.

## 3-7. Initial Conditions.

3-8. Initialize the instrument as follows:

- a. Connect the power cord to the instrument and the desired power source. Refer to paragraph 2-7 for proper power application.
- b. Set the LINE ON power switch to ON.
- c. Wait several seconds then depress the INIT key.

## 3-9. Programming Measurement Parameters.

3-10. Measurement parameters for each channel of the instrument are entered into the microprocessor through the front panel keyboard. To eliminate the need for repeated reprogramming, parameters entered through the keyboard are stored in non-volatile memory, and the stored parameters are unaffected by instrument turn OFF and turn ON. It is important to remember that the last used parameters are stored in the instrument because these stored parameters could cause what appear to be erroneous indications when subsequent measurements that require different parameters are made. Measurement parameters may be changed at any time. The following keys may be used to recall the last entered value for the corresponding functions: AVERAGE SEL, SELECT PROBE SELECT  $Z_0$ , SELECT CHNL, and REF LEVEL dB.

## NOTE

Entered measurement parameters apply only to the channel in use at the time that the para-

meter entries were made. If the instrument is equipped with the second channel option (option 9200B-03), different measurement parameters may be entered for channel 1 and channel 2. When either channel is selected thereafter, measurement parameters that have been entered for that channel are invoked automatically by the microprocessor.

3-11. When the instrument is in store or recall mode, the LED display and annunciators blink on and off to alert the operator to the fact that the displayed value is not a measured value, but a value that has been recalled from instrument memory or that is to be entered into memory.

## 3-12. Probe Selection.

3-13. The Model 9200B is supplied with either the Model 952001A high impedance probe or the Model 952009 50  $\Omega$  sensor as ordered for channel 1 (and channel 2, option 9200B-03 if ordered).

## 3-14. Use of Numerical Keys.

3-15. The numerical keys are used to enter values for SELECT, PROBE SELECT, AVERAGING CONSTANT,  $Z_0$  and REF LEVEL dB functions. When any numerical key is pressed, the microprocessor interrupts the measurement operation to accept new data. Numerical values are entered in normal sequence and keyed-in values enter the instrument display from right to left. Up to four digits, plus decimal point and minus sign, can be entered; entries exceeding four digits are ignored. Pressing the decimal point key places a decimal point after the right most digit in the instrument display. Pressing the CHS key changes the sign of the entry (plus becomes minus, or minus becomes plus); the plus sign is not displayed. If an error is made during entry of numerical values, press the CLR key and repeat the data entry process. When the instrument display shows the desired numerical value, pressing the applicable SELECT or dB REF LEVEL key will cause the microprocessor to store the keyed-in value and return automatically to the measurement cycle.

## 3-16. CLEAR key.

3-17. If an error is made in keying in a numeric entry pressing the CLEAR key will clear the display to all zeros and the value may be re-keyed. Additionally, the CLEAR key may be used to clear to zero the value stored for dB reference by pressing the CLEAR key followed by the REF LVL dB key. During IEEE-488 Bus operations, the CLEAR key is used as the Return to Local key, whereby pressing it returns control of the instrument to the front panel.

## 3-18. SELECT Keys.

3-19. The SELECT keys are used by the operator to specify the number of the measurement channel and the probe.

SECTION III  
OPERATION

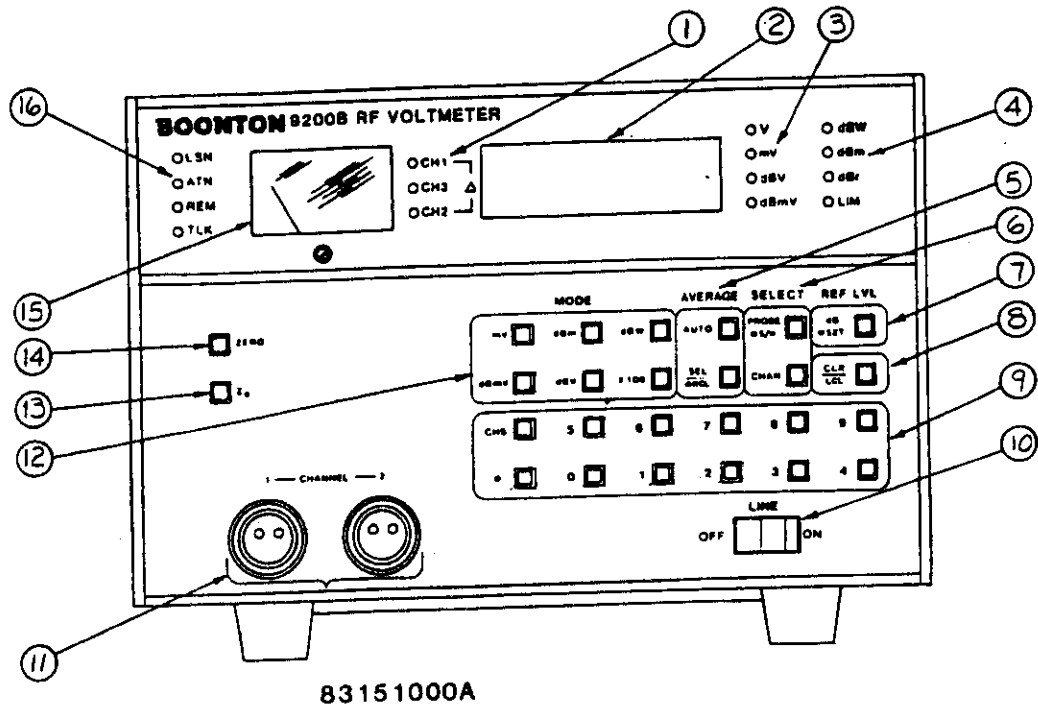

Figure 3-1. Model 9200B, Front View.

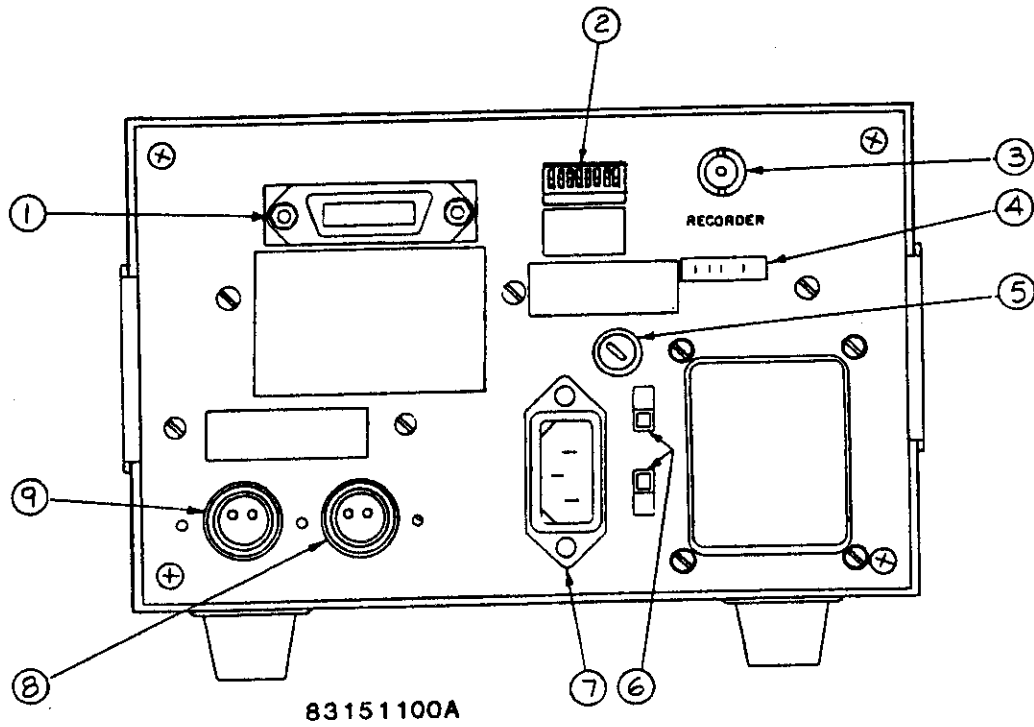

Figure 3-2. Model 9200B, Rear View.

TABLE 3-1. OPERATING CONTROLS, INDICATORS, AND CONNECTORS

Control, Indicator, or Connector	Figure and Index No.	Function
CH1, CH3 and CH2 annunciators	3-1, 1	Indicates which channel has been selected for use.
LED display	3-1, 2	Four digit LED display with minus sign and decimal point; provides numeric indication of measured voltage or dB level, or data entered or recalled through keyboard, or error messages.
V, mV, dBV and dBmV annunciators	3-1, 3	Indicate measurement units.
dBm, dBw, dB <sub>r</sub> , and LIM annunciators	3-1, 4	Indicate whether displayed measurement values in dB modes are absolute (dBm) or relative (dB <sub>r</sub> ) values.
AVERAGE keys	3-1, 5	
AUTO		Selects automatic averaging operation.
SEL ●RCL		Provides means for entering or recalling range averaging constant.
SELECT keys	3-1, 6	
PROBE ●S/N		Provide means for entering or recalling probe number or serial number.
CHAN		Provides means for entering or recalling channel number (CHNL).
REF LEVEL key	3-1, 7	Provides means for entering or recalling a dB reference level.
dB ●SET		
CLR Key LCL	3-1, 8	Provides means for clearing incorrect digit(s) entry, clearing dB calibration factor and dB Ref level to zero, and returns to local under bus operation provided local lockout (LLO) is not active.
Numeric, decimal point and CHS keys	3-1, 9	Provide means for entering signed numeric data.
LINE switch	3-1, 10	Controls application of AC line power to instrument.
PROBE connectors	3-1, 11	Provides means for connecting probes to input channels of instrument.
MODE keys	3-1, 12	Provide means for selecting display indication mode (mV, dBm, dBmV, dBV, dBw or X100).
Z <sub>0</sub> key	3-1, 13	Provides means for entering or recalling reference impedance for dB mode measurements.
ZERO key	3-1, 14	Provides means for automatic acquisition and storage of zero corrections for each range.
Meter	3-1, 15	Provides relative indication of voltage or dB for peaking and nulling operations.
LSN, ATN, REM and TLK annunciators	3-1, 16	Provide indication of activity when IEEE 488 bus interface option 9200B-01B is in use.

SECTION III  
OPERATION

TABLE 3-1. OPERATING CONTROLS, INDICATORS, AND CONNECTORS (Continued)

Control, Indicator, or Connector	Figure and Index No.	Function
J1 connector	3-2, 1	Option: provides IEEE 488 bus connections when option 9200B-01B is installed.
S1 switch	3-2, 2	Option: used to set address of instrument and termination characters when IEEE 488 bus option 9200B-01B is installed.
RECORDER connector	3-2, 3	Provides analog DC output, which is proportional to measured voltage or dB level, for application to recorder.
P3 connector	3-2, 4	Provides logic signal outputs for input disconnect during zeroing, high dB limit and low dB limit.
Fuseholder	3-2, 5	AC line fuseholder.
Line Voltage Selector Switches	3-2, 6	Selects the desired operating voltage.
AC power connector	3-2, 7	AC power connector.
REAR CHNL 2 connectors	3-2, 8	Provides means for rear connection to input channel 2.
REAR CHNL 1 connectors	3-2, 9	Provides means for rear connection to input channel 1.

3-19. (Continued).

NOTE

Selecting a channel also selects probe data and measurement parameters that had been entered into non-volatile memory for that channel and PROBE (SENS).

a. The basic instrument contains only one measurement channel. This channel is designated channel 1 and the front and rear panel CHANNEL connector provides the input to this channel. An option is available for the addition of a second measurement channel. When this option (option 9200B-03) is included, the additional measurement channel is designated channel 2.

b. To further enhance the usefulness of the instrument, a channel 3 operation may be exercised if the instrument is equipped with option 9200B-03. The indication in channel 3 mode is, the Display equals:

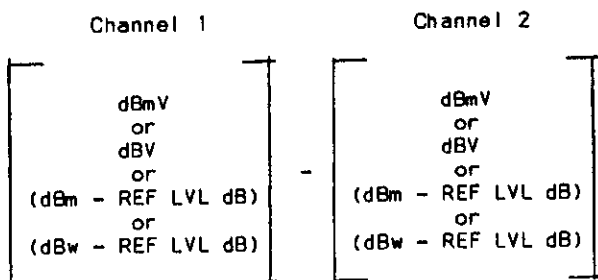

The dB mode operative for each channel in channel 3 operation is the last dB mode chosen for that channel prior to selection of channel 3 operation. This is true even if the mV mode is chosen prior to channel 3 selection. Mixed modes are also possible, that is, either channel may be operating in any of its modes (mV, dBmV, dBV dB or dBw). If either or both channels are operating in the dB mode, the REF LEVEL dB function is also operative. Examples of channel 3 operation are listed in Table 3-2.

c. Channel 1 measurements, channel 2 measurements or the channel 3 function can be selected using the numerical keys and the SELECT CHNL key.

Example: To select the channel 1 input for measurement:

<u>Press</u>	<u>Display</u>
1	0001
SELECT CHNL	Reverts to measurement.

Example: To select a reference impedance of 50 ohms:

<u>Press</u>	<u>Display</u>
5	0005
0	0050
SELECT Z <sub>0</sub>	Reverts to measurement.

TABLE 3-2. EXAMPLES OF CHANNEL 3 MEASUREMENTS

Channel 1						
Meas. No.	Input	Mode	Z <sub>0</sub>	REF LEVEL dB	Display	
1	1000 mV	mV	-	0	1000 mV	
2		dBmV	-	0	60.00 dBmV	
3		dBV	-	0	00.00 dB	
4		dBm	50	0	13.01 dBm	
5		dBm	50	5	8.01 dBm	
6		dB	50	5	8.01 dB	
7		mV	50	5	1000 mV	
8		mV	50	5	1000 mV	

Channel 2						
Meas. No.	Input	Mode	Z <sub>0</sub>	REF LEVEL dB	Display	Channel 3 Display
1	1000 mV	mV	-	0	1000 mV	(See Note)
2		dBmV	-	0	60.00 dBmV	00.00 dB
3		dBmV	-	0	60.00 dBmV	-60.00 dB
4		dBm	50	0	13.01 dBm	00.00 dB
5		dBm	50	0	13.01 dBm	-05.00 dB
6		dBmV	50	0	60.00 dBmV	-51.99 dB
7		dBmV	50	0	60.00 dBmV	-51.99 dB
8		mV	50	0	1000 mV	-51.99 dB

NOTES:

For No. 1 measurement, the channel 3 indication is a function of previously selected dB modes, unknown at this time.

For No. 2 measurement, the channel 3 indication = 60 dBmV - 60 dBmV = 0 dB.

For No. 3 measurement, the channel 3 indication = 0 dBV - 60 dBmV = -60 dB.

For No. 4 measurement, the channel 3 indication = 13.01 dBm - 13.01 dBm = 0 dB.

For No. 5 measurement, the channel 3 indication = (13.01 dBm - 5 dB) dB - 13.01 dBm = -5 dB.

For No. 6 measurement, the channel 3 indication = (13.01 dBm - 5 dB) dB - 60 dBmV = -51.99 dB.

For No. 7 and No. 8 measurements, the channel 3 indication is the same as for the No. 6 measurement because if the mV mode was chosen for channel 1 and/or channel 2 prior to channel 3 selection, that channel will revert to the dB mode used prior to selection of the mV mode.

## 3-20. Probe (Sensor) Select.

3-21. The Model 9200B can accommodate data storage for up to eight probes or sensors. The desired probe is selected by pressing N (N: digit 1 thru 8) and SELECT PROBE keys. The data for N Probe (if previously stored see Section 4-33) will now be used in the measurement process. The probe number for data in effect can be recalled by pressing the SELECT PROBE key. The display will show the probe number. The serial number of each

probe (sensor) is also stored in the instrument's memory and can be recalled by pressing the ●, SELECT PROBE keys. This is helpful in assuring that the correct probe has been installed and selected. If the probe (sensor) number is not known, the correct data can be recalled by entering the last four digits of the probe (sensor) serial number followed by pressing the ●, SELECT PROBE keys. The correct data and probe number will now be matched to the probe in use.

SECTION III  
OPERATION

3-22. If a particular probe (sensor) is desired with a particular channel this is obtained by selecting the channel first followed by the probe selection (e.g. 1 CHNL, 1 PROBE). Whenever Channel 1 is now selected Probe 1 is also selected.

3-23. PROBE (SENS) Serial Number Recall.

3-24. To recall the serial number of a probe, first select the probe (N, PROBE), then press ●, PROBE keys. The display will now show the serial number for the probe selected. PROBE (SENS) serial number entry is covered in Section 4-33.

3-25. MODE Selection.

3-26. The MODE keys enable the operator to select the desired measurement mode. When the MODE mV key is pressed, measurement values are displayed in millivolts. When the MODE dBmV key is pressed, measured levels are displayed in dB referred to 1 millivolt. When the MODE dBV key is pressed, measured levels are displayed in dB referred to 1 volt. When the MODE dBm key is pressed (and a 0 dB reference level has been entered), measured levels are displayed in dB referred to the voltage that produces 1 milliwatt in the selected  $Z_0$  reference impedance (the  $Z_0$  value must be entered through the keyboard). When the MODE dBw key is pressed (and a 0 dB reference level has been entered), measured levels are displayed in dB referred to the voltage that produces 1 watt in the selected  $Z_0$ . The displayed numerical values may be expressed as follows:

$$dB = 20 \log \frac{e_{\text{measured}}}{e_{\text{reference}}}$$

$$\text{For dBm, } e_{\text{reference}} = (Z_0 \times 10^{-3})^{1/2}$$

$$\text{For dBw, } e_{\text{reference}} = (Z_0)^{1/2}$$

3-27. In the dB mode, entering a dB reference level other than 0 causes lighting of the dBm annunciator and displayed dB mode measurement values represent dB with respect to the selected reference level. Resolution of the instrument in any dB mode is 0.01 dB.

3-28. REF LEVELS dB Selection.

3-29. The following standard reference levels are operative in the dB modes:

Mode	Level (0 dB)	Annunciator
dBmV	1 mV	dBmV
dBV	1 V	dBV
dB( $Z_0$ )	dB( $Z_0 \times 10^{-3}$ ) <sup>1/2</sup>	dBm
dBw( $Z_0$ )	dB( $Z_0$ ) <sup>1/2</sup>	dBw

3-30. Entering a number other than 0 into the REF LEVEL dB results in this number becoming the reference level for the dB mode. The display will indicate reference level and the dBm annunciator will be activated. The dB reference level affects the dB mode only. The dB reference level may be entered while any mode is being used, but the result of the entry will be apparent only when returning to the dB mode.

3-31. It is possible to select the present dB level as the dB reference level by pressing the ● and REFERENCE LEVEL dB keys.

a. To display dBm to a reference level of -15.3 dB:

Press	Display	Annunciators	
		dBm	dBm
MODE dBm	Measurement	ON	OFF
CLR	0000	ON	OFF
REF LEVEL dB	dB Measurement	ON	OFF
1	0001	ON	OFF
5	0015	ON	OFF
●	0015.	ON	OFF
3	015.3	ON	OFF
CHS	-015.3	ON	OFF
REF LEVEL dB	dB Measurement	ON	ON

NOTE

Maximum display capability for dBm is  $\pm 99.99$  dB.

b. To return to a dBm measurement:

Press	Display	Annunciators	
		dBm	dBm
0 or CLR	0000	ON	ON
dB REF LEVEL	dB Measurement	ON	OFF

3-32. Select  $Z_0$ .

3-33. The SELECT  $Z_0$  key enables the operator to enter a desired reference impedance for dB mode measurements. (When the MODE dBm key is pressed, measured input levels are displayed in dBm referred to the voltage that produces 1 milliwatt of power in the selected reference impedance.) Valid  $Z_0$  values are 5 through 2500 ohms.

Example: To select a reference impedance of 50 ohms:

Press	Display
5	0005
0	0050
SELECT $Z_0$	Reverts to measurement.

3-34. AVERAGE Function Selection.

3-35. To reduce the effects of noise, spurious components, etc. at lower levels, the Model 9200B employs signal averaging. The amount of averaging is a function of signal level, being highest on the lowest ranges and least on the highest ranges. When the instrument is first turned on a set of default values is assigned as follows:

fs LEVEL	RANGE	CONSTANT
3000 mV	7	1
1000 mV	6	1
300 mV	5	1
100 mV	4	1
30 mV	3	2
10 mV	2	4
3 mV	1	20
1 mV	0	80

3-36. Increasing or decreasing these values may be accomplished by pressing N (N=1 to 127) and then the AVERAGE SELECT key. This new constant will now be in effect on all ranges and will remain in effect until changed by entering a different value, or until the AVERAGE AUTO key is pressed or the instrument is turned OFF/ON after which the default values will again be in effect. The value of the constant in effect can be recalled by pressing the  $\odot$ , AVERAGE SEL keys. The default values when in the AUTO mode cannot be recalled.

## NOTE

Some early production models allow the average to be set on individual ranges. If a new average is selected it will be in effect only on the range that the instrument was on when it was selected, all other operations remain the same. To test for this operation press the  $\odot$ , AVERAGE SEL keys. If the constant listed for that range (refer to paragraph 3-35) is returned on the display, the instrument has the older software. If 0 is returned on the display, the instrument has the updated software.

## 3-37. X100 Key.

3-38. The X100 key is used with the 952005 100:1 Voltage Divider. By pressing the X100 key when the 952005 Divider is installed on a probe, the display is corrected to read the true voltage or dB and is active in all voltage and dB modes. This saves the operator from making a mental correction or recalculating dB by hand. The X100 function can be used independently on both channels and the X100 annunciator will light to inform the operator that the channel selected is in the X100 mode. To return to the X1 mode, press the X100 key.

## 3-39. Zeroing the Instrument.

3-40. For greatest accuracy, especially on the more sensitive ranges, the instrument must be zeroed. To eliminate the need for tedious and often inaccurate manual zeroing, the instrument incorporates an automatic zeroing capability. When automatic zeroing is initiated, the microprocessor reads, averages and stores zero corrections for each measurement range of the instrument and applies the proper zero correction for the range in use for all subsequent measurements. Zero corrections are most important on the more sensitive ranges of the instrument. During instrument warmup periods and during use in environments with varying ambient temperatures, the instrument should be zeroed frequently if measurements are being made on the lower ranges. To zero the instrument, proceed as follows:

## CAUTION

Never press the ZERO key with a signal applied to the probe. To do so will result in erroneous zero corrections and inaccurate subsequent measurements. If the input exceeds normal zero offsets, error flag cc 6 will be displayed when automatic zeroing is initiated; remove the input signal and re-zero the instrument.

a. Remove all input signal to the probe. This can be done by unscrewing the probe tip until the tip just breaks contact with the internal connection, leaving the metal shell engaged with the probe body threads. Alternatively, the probe tip can be removed and a Model 952002 50  $\Omega$  adapter connected in its place.

b. Press the ZERO key. The automatic zeroing cycle takes approximately 18 seconds; the microprocessor computes and stores zero corrections during this this period. When the ZERO key is pressed, a logic signal is activated at rear panel connector J3; this signal can be used to initiate turn-off of the device to which the instrument probe is connected if such operation is desired. When zeroing is complete, the instrument display shows cc 3 in all dB modes, indicating input underrange. In the mV mode, the underrange indication does not appear; the instrument display shows the "zero condition". This is composed of residual noise and offsets and, ideally, should show + and - excursions of similar amplitude less than 100 counts.

## 3-41. Making Measurements.

3-42. Once the instrument has been programmed and zeroed, it is ready for voltage or dB level measurements. Merely connect the probe to the source whose voltage or dB level is to be measured; the measured level will be displayed directly.

## 3-43. Recall and Entry of Non-Volatile Memory Data Operation.

## NOTE

Factory entered data is shown on a hard copy stored under the top cover of the instrument.

3-44. Instrument and probe data is entered in to the instrument non-volatile memory depending on what options and probes are ordered with the instrument. Field entry of data is not required unless the stored data is destroyed, data accuracy becomes questionable, or if another probe is to be used with the instrument.

## 3-45. Recall and Entry of Instrument Gain Data.

3-46. Instrument Gain Data. The front end of the instrument input module is a balanced-input DC amplifier with seven decade ranges with nominal full-scale inputs of 20 microvolts to 20 volts. The output is an unbalanced DC with a 2.5 volt full-scale value for each range; the DC is converted into a proportional digital value. One manual gain adjustment, potentiometer R44, adjusts the gain of all ranges by the same amount; this adjustment is factory set during instrument calibration. Individual range adjustments are accomplished through software correction or adjustment, which is also determined during instrument calibration. The software corrections are stored in the instrument non-volatile memory. A gain factor associated with the recorder DC output is also stored in memory.

## SECTION III OPERATION

3-47. Gain Factor Recall. Recall the instrument gain factors stored for each channel of the instrument as follows:

- a. Set the control board bit switch to mode 1. Refer to Figure 5-1.
- b. Using the instrument keyboard, select the channel for which gain factors are to be recalled. For example: to select channel 1, press the 1 and SELECT CHNL keys.
- c. Press the MODE dBw key. The instrument display will show approximately 1185; this is the recorder output gain factor.
- d. Using the keyboard keys, select the range to be checked. For example: to select range 0, press the 0 and MODE dBV keys.
- e. Press the REF LEVEL dB key. The instrument display will indicate the gain factor stored for the selected channel and range; this value should be in the vicinity of 1000.
- f. Repeat steps c and e for each of the remaining ranges to be checked.
- g. After all desired gain factors have been recalled, reset the control board bit switch to mode 0.

3-48. Instrument Gain Factor Entry. Correct or reintroduce an instrument gain factor as follows:

- a. Set the control board bit switch to mode 1.
- b. Using the keyboard keys, select the channel for which gain factor correction or reintroduction is required. For example: to select channel 2, press the 2 and SELECT CHNL keys.
- c. Using the keyboard keys, select the range for which the gain factor is to be corrected or reintroduced. For example: to select range 2, press the 2 and MODE dBV keys.
- d. Using the keyboard keys, enter the desired gain factor as a REF LEVEL dB value. For example: to enter a gain factor of 1023, press the 1, 0, 2 and 3 numeric keys, then press the REF LEVEL dB key.
- e. Press the REF LEVEL dB key a second time. The instrument display will indicate the entered gain factor value.
- f. Repeat steps c through e for each of the remaining ranges for which entry of a gain factor is desired.
- g. Upon completion of gain factor entries, reset the control board bit switch to mode 0.

3-49. Recall and Entry of Probe Data.

3-50. Probe (SENS) Serial Number Entry. Enter the probe serial number as follows:

- a. Set the control board bit switch to MODE 2. Refer to Figure 5-2.

- b. Select the probe (SENS) number (1 through 8) with N, PROBE keys.

- c. Enter the probe (SENS) serial number with digit keys N, N, N, N and depress the AVERAGE AUTO key.

- d. Set the control board bit switch to MODE 0 (OPERATE MODE).

- e. The probe (SENS) serial number can be recalled by pressing the ●, PROBE keys.

3-51. Probe Data Recall. Recall stored probe data as follows:

- a. Set the control board bit switch to mode 0.
- b. Using the keyboard keys, select the probe for which stored probe data is to be recalled. For example: if stored data for the 1 probe is to be recalled, press the 1 and SELECT PROBE keys.
- c. Set the control board bit switch to mode 2.
- d. Using the keyboard keys, select the range for which the probe gain factor is desired. For example: if the gain factor for range 0 is to be recalled, press the 0 and MODE dBV keys.
- e. Press the REF LEVEL dB key. The instrument display will show the stored gain factor (approximately 5000) for the selected range.
- f. Press the MODE dBw key. The instrument display will show a down-scale correction (generally 0 on range 0).
- g. Repeat steps d through f for each of the other ranges for which the stored gain factor is to be recalled.
- h. Set the control board bit switch to mode 0.

3-52. Probe Gain Factor and Gain Correction Entry.

3-53. Probe (sensor) data cannot be entered for a probe (SENS) number which is not accommodated by the control board bit switch setting for N PROBE (SENS) capability. If this is attempted, the instrument will display an error message. If the instrument was originally supplied with 2 probes and it is desired to enter data (or calibrate) for a third, bit switches 4, 5 and 6 will have to be set for 3 probe capability with the new data entered for probe 3. Refer to Figure 5-4 for the bit switch settings for 1 through 8 probe (sensor) capabilities. Proceed as follows:

- a. Using the keyboard keys, select the probe for which the data is to be entered. For example: if the data to be entered applies to probe 1, press the 1 and PROBE (SENS), SELECT PROBE keys.

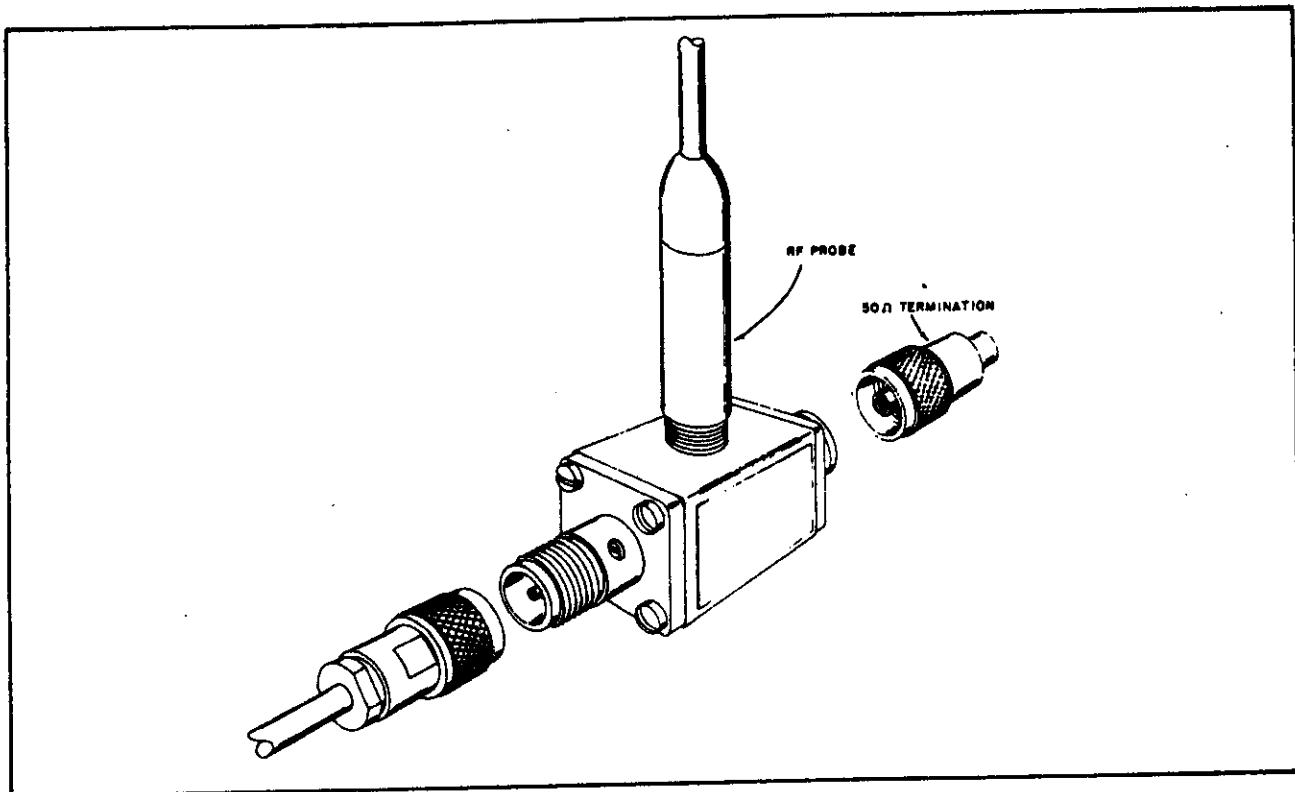

Figure 3-3. Attachment of Model 952003 50 Ohm N Tee Adapter to Model 952001A Probe and Model 952014 50 Ohm Termination.

3-53. (Continued).

- b. Set the control board bit switch to mode 2.
- c. Using the keyboard keys, select the range for which a probe gain factor entry is to be made. For example: If the probe gain factor for range 0 is to be entered, press the 0 and MODE dBV keys.
- d. Using the numerical keys, enter the probe gain factor for the selected range; then, press the REF LEVEL dB key. For confirmation of correct probe gain factor entry, press the REF LEVEL dB key a second time; the stored probe gain factor for the selected range will appear on the instrument display.
- e. Repeat steps c and d for each of the other instrument ranges for which probe gain factors are to be entered.
- f. Select the instrument range for which the probe gain correction is to be entered. For example: If the probe gain correction for range 2 is to be entered, press the 2 and MODE dBV keys.
- g. Using the numerical keys, enter the probe gain correction for the selected range, then press the MODE X100 key. For confirmation of

correct probe gain correction entry, press the MODE X100 key a second time; the stored gain correction for the selected range will appear on the instrument display.

- h. Repeat steps f and g for each of the other instrument ranges for which probe gain corrections are to be entered.

- i. Upon completion of data entry, reset the control board bit switch to mode 0.

### 3-54. Application Notes.

#### 3-55. Overload Limits.

- a. The Model 952001A RF Probe supplied with the instrument is overload protected to 10 volts AC and 400 volts DC. Exceeding these limits may result in permanent damage.
- b. The Model 952002 50  $\Omega$  BNC Adapter supplied with the instrument should not be subjected to continuous overload of more than 10 volts (DC + RMS AC) in order to avoid excessive heating of the terminating resistor.
- c. Where voltages above the specified overload limits are likely to be encountered, use the Model 952005 100:1 Voltage Divider. Maximum rating of the voltage divider is 1000 volts (DC + peak AC).

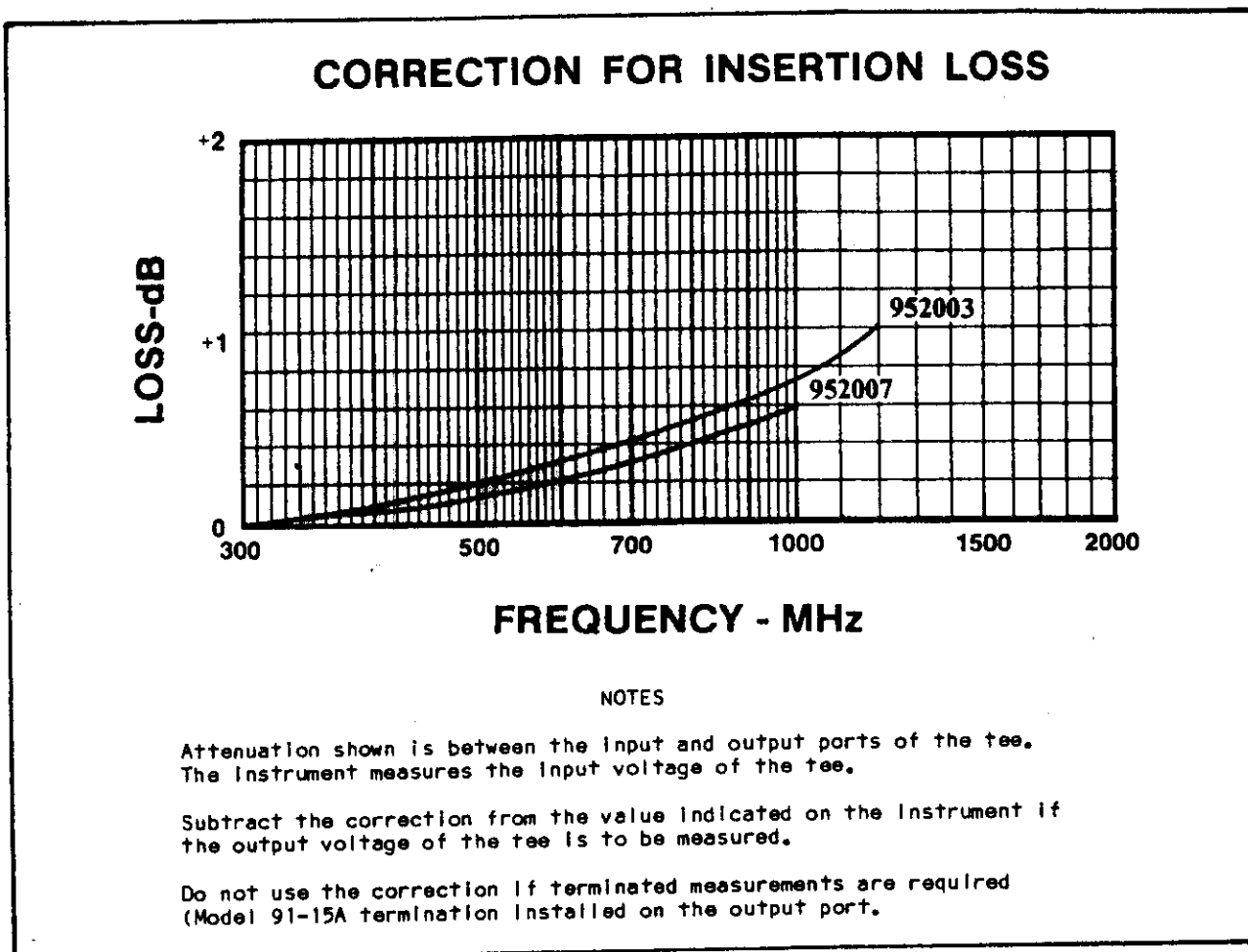

Figure 3-4. Correction Curves for Models 952003 and 952007 Type N Tee Adapters.

3-55. (Continued).

d. The terminated Model 952009 RF Probe is overload protected to 4 volts AC and 400 volts DC. Exceeding these limits may result in permanent damage.

3-56. Connection Recommendations.

a. The Model 952001A probe is equipped with a detachable tip and ground lead. For measurement of signals below approximately 100 MHz, this tip provides a convenient means for making both signal and ground connections.

b. For frequencies above 100 MHz, the probe tip should not be used because the series impedances of the connection will affect the voltage level at the probe and cause an error in measurement. For high impedance voltage measurements, connection should be made directly to the center contact of the RF probe, with the ground connection kept as short as possible. For matched impedance measurements, one of the various terminated adapters, tee adapter or Model 952009 Probe should be used Refer to Figure 3-3.

3-57. Low Level Measurements.

a. The Instrument will provide reliable, reproducible measurements of signal levels as low as 200 microvolts. Useful indications extend down to 50  $\mu$ V. Zeroing of the Instrument is essential when using the lower ranges in order to achieve the specified accuracy. Zeroing is also strongly recommended for all ranges up to 30 millivolts. Refer to paragraph 3-39 for the zeroing procedure.

3-58. Temperature Effects.

a. The accuracy specifications for the Instrument apply over a temperature range of 0°C to 50°C. Outside these limits, operation of the Instrument is possible, but appreciable inaccuracies can be expected; however, no permanent change in probe characteristics will result from any reasonably high or low temperature exposure.

b. It should be noted that inaccuracies of measurement resulting from temperature effects may occur shortly after soldering to the RF probe tip, or measuring with the probe in the vicinity of heat sources such as resistors, heat sinks and so forth.

3-58. (Continued).

c. When making low level measurements (below approximately 2 millivolts), it is important to make sure that the probe has attained a uniform temperature throughout its body. A temperature gradient between the inside and outside of the probe can generate a small thermal voltage that may add to the DC output of the detector diodes.

3-59. Hum, Noise and Spurious Pickup.

a. When measuring low level signals, precautions should always be taken to avoid the possibility of measurement errors resulting from hum, noise or stray RF pickup. Although all low frequency hum and noise are attenuated at the input, unwanted high level signals could still possibly cause errors. In some cases it may be necessary to provide extra shielding around the probe connection to reduce stray pickup. Some typical sources of spurious radiation are induction or dielectric heating units, diathermy machines and local radio transmitters.

3-60. Recorder Output.

a. The DC output provided at the rear panel RECORDER connector may be used to drive an XY recorder for swept measurements, or a strip chart recorder for monitoring applications. Refer to Section II, paragraph 2-12.

3-61. Correction Curve for Model 952003 50  $\Omega$  N Tee Adapter.

a. When using the optional Model 952003 50  $\Omega$  N Tee Adapter, the input voltage to the adapter is indicated directly on the instrument. To obtain the correct output voltage from the adapter, subtract the correction shown in Figure 3-4 from the input voltage, in dB, indicated on the instrument. Corrections are not required if the Model 952003 is terminated in 50  $\Omega$ .

3-62. Correction Curve for Model 952007 75  $\Omega$  N Tee Adapter.

a. When using the optional Model 952007 75  $\Omega$  N Tee Adapter, the input voltage to the adapter is indicated directly on the instrument. To obtain the correct output voltage from the adapter, subtract the correction shown in Figure 3-4 from the input voltage, in dB, indicated on the instrument. Corrections are not required if the Model 952007 is terminated in 75  $\Omega$ .

SECTION IV  
THEORY OF OPERATION

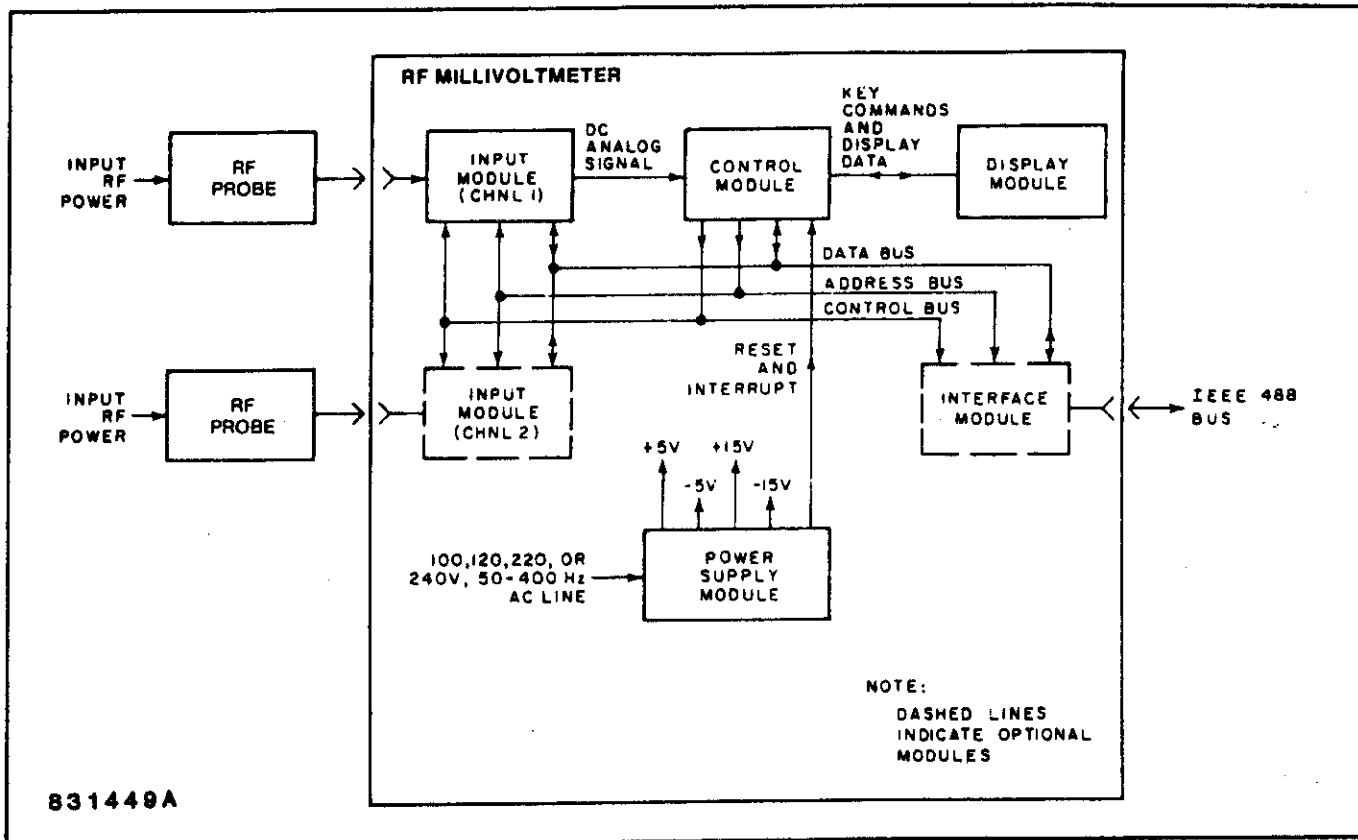

Figure 4-1. Functional Block Diagram.

4-1. INTRODUCTION

4-2. The Model 9200B is capable of measuring RF voltage levels from 200 microvolts to 3 volts. The instrument is completely solid-state and employs a microprocessor for versatility and convenience of use. The microprocessor is controlled by a permanently stored internal program. Desired operating parameters are entered by means of a front-panel keyboard. Use of a microprocessor permits automation of numerous functions, such as zeroing, range selection, unit conversion, dB limit testing, relative dB measurements, etc. Measured values are displayed directly on a 4 digit LED display in terms of V, mV, dBmV, dBV, dBm, dBw or dB<sub>r</sub> (relative dB). Annunciators associated with the display indicate the unit of measurement. An analog meter is also provided for relative voltage measurements; this feature simplifies such operations as nulling and peaking. A DC voltage that is proportional to the measured value is available at a rear-panel connector.

4-3. FUNCTIONAL BLOCK DIAGRAM DESCRIPTION  
(Refer to Figure 4-1.)

4-4. Probe. RF levels to be measured are applied to an external probe, which connects to the CHANNEL connector on the front panel of the instrument. The probes convert the applied RF voltage to a DC voltage. The DC voltage is supplied to the input module of the instrument.

4-5. Input Module. The input module receives the DC voltage developed by the probe. Operating under control of the control module, the input module converts the DC voltage to an AC voltage, amplifies this AC voltage, converts it to an analog DC voltage and converts this to a digital signal. If the autoranging function of the instrument has been selected, the gains of the amplifiers in the input module are adjusted automatically by the control module to accommodate any voltage level within the range of the instrument. The digital output signal of the input module is supplied to the control module for additional processing; an analog DC output signal is developed from the digital signal and this analog DC signal is applied to the analog meter in the display module for relative voltage measurements and to a rear panel connector for application to a peripheral recorder.

## SECTION IV THEORY OF OPERATIONS

**4-6. Control Module.** The control module consists primarily of a preprogrammed microprocessor. The microprocessor accepts and stores measurement parameter commands entered through the front panel keyboard, and controls operation of the internal circuits of the instrument in accordance with its program and keyed-in commands. The microprocessor performs measurement value corrections based on stored zero corrections and stored gain and range linearization factors, unit conversions based on selected measurement modes and dB limit determination. The microprocessor also performs key-initiated automatic zeroing. The processed digital signal, which defines the final measurement value, is applied to a data bus and to the display module.

**4-7. Display Module.** The display module contains the keyboard and LED display circuits. Parameters to be used for measurements can be entered at any time through the keyboard and can also be recalled for checking. Keyed-in values are read and stored by the microprocessor and keyed-in numerical values are shown on the display during parameter entry. Computed voltage levels are processed by the microprocessor in accordance with the keyed-in data; the digital values representing the final computer measurement values are decoded by the display module circuits to produce a direct LED readout of measured values and to activate the proper annunciators.

**4-8. Power Supply Module.** The power supply module provides all DC voltages required for operation of the internal circuits of the instrument. It also provides a reset signal to the control module when power is applied and an interrupt signal if an undervoltage condition is detected. The power supply module can be powered from a 100, 120, 220 or 240 volt, 50 to 400 Hz, AC power source.

**4-9. Optional Modules.** Refer to Figure 4-1. The following options are available:

a. The interface module (option -01B) provides an IEEE 488 bus interface for remote control of instrument operation and for remote access to measured values.

b. A second input module (option -03) can be added to the instrument to permit measurement of voltage levels at two locations without the need for repeated switching of probe connections. The second input module also permits display of the difference between the levels at the two locations, expressed in dB.

### 4-10. DETAILED CIRCUIT DESCRIPTIONS

**4-11. Probe Circuits.** The RF probes used with the instrument convert RF to DC. The RF voltage applied to the probes is rectified by a full-wave detector that employs factory-selected diodes with special characteristics, including low capacitance and controlled thermal offsets. The resulting DC voltage is a function of the applied RF voltage.

**4-12.** A full-wave detector, unlike a single-diode detector, permits measurement of highly asymmetric waveforms without substantial error. When a voltage of asymmetric waveform is impressed on a single-diode detector circuit, whether or not the portion of the waveform that turns on the diode is restricted to the square-law region of the diode's characteristic, the recovered DC voltage is dependent upon the phase of the input voltage. Consider a positive pulse of low duty cycle applied to the anode of a diode detector. The recovered DC voltage is a function of the polarity, amplitude and duration of the pulse. If the pulse is inverted, it drives the diode into a reverse bias condition and the recovered DC voltage is zero. A full-wave detector circuit, on the other hand, yields an equal amount of DC irrespective of the polarity of the input pulse. The average voltage of a pulse obviously does not depend upon the phase of the pulse. The response of a single diode detector, square law characteristic notwithstanding, cannot reflect this; a full-wave detector circuit does.

**4-13.** Probe response is true RMS for inputs below 30 mV. Above this voltage level, the probe response gradually changes, approaching peak-to-peak at the higher voltage levels, however, the voltage data is digitally shaped in the instrument to indicate RMS voltage, provided that the input is reasonably sinusoidal as is the case with CW and FM signals. The body of the probe has been designed and fabricated to eliminate any cavity resonance effects within the calibrated frequency range and to minimize noise. The DC output voltage from the probe is applied to the CHANNEL connector of the instrument through a low-noise probe cable.

**4-14. Input PC Board Circuits.** Refer to Figure 4-2. The input printed circuit board receives from the probe a DC voltage that is a function of the RF voltage level being measured. Under control of the control board circuits, it provides amplification and signal processing required to develop an analog DC voltage and a digital signal that are both proportional to the input RF voltage level. The input DC voltage from the probe is balanced in form and may vary from microvolts to volts, depending upon the input RF voltage level. The input printed circuit board must provide amplification with a wide range of gain, low offset voltage and low noise; therefore, the input DC voltage is converted to an AC voltage which is amplified and the amplified AC voltage is converted to a DC analog signal and to a digital signal.

**4-15.** The input DC voltage is converted to an AC voltage by a chopper module, which plugs in to the input printed circuit board. The chopper is composed of solid-state switches IC1a through IC1d in a balanced arrangement, operating at a frequency of approximately 94 Hz to minimize AC line and line-related component interaction. The chopper drive signal is derived from the output of an astable multivibrator, which is

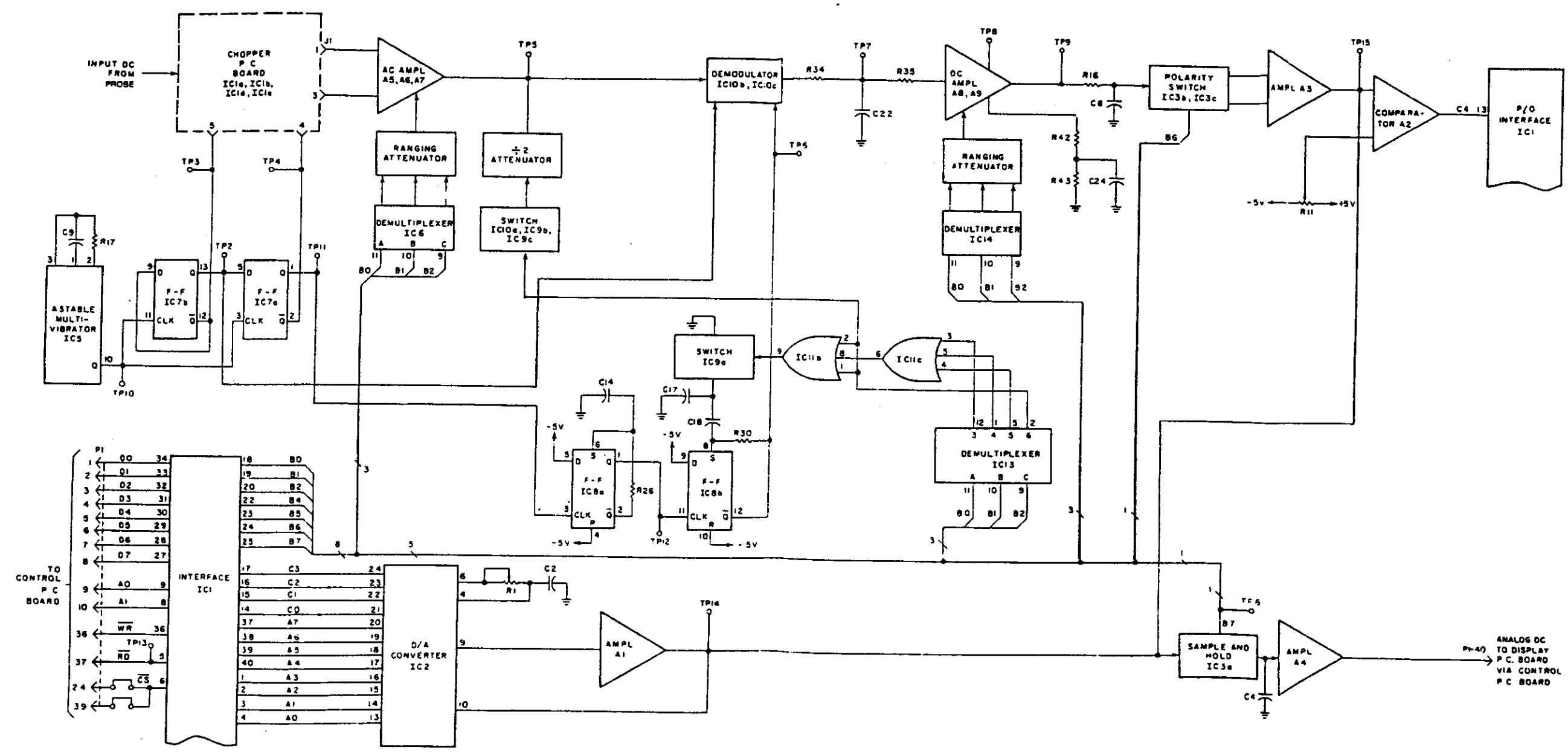

831450B

Figure 4-2. Input PC Board  
Detailed Block Diagram

## 4-15. (Continued).

completely independent of line frequency. The use of a solid-state chopper eliminates many of the problems, such as contact wear and contamination, associated with electro-mechanical choppers. The chopper supplies a balanced AC signal of approximately 94 Hz to the input amplifier.

4-16. Amplification of the balanced 94 Hz AC signal from the chopper is accomplished by an input amplifier composed of low-noise operational amplifiers A5, A6 and A7. A balanced arrangement with degenerative feedback for stabilization and gain control is employed. The input AC signal is amplified by 500, 50, 5 or 0.5, depending upon the instrument range. Demultiplexer IC6, under control of the control printed circuit board, adjust the degenerative feedback in accordance with the range selected by the microprocessor to provide the required gain switching. An attenuator at the output of the input amplifier provides attenuation of 5 for the highest range only; on all other ranges its attenuation is 1. This attenuator is switched into the circuit on the highest range through solid-state switches IC10a, IC9b and IC9c. Demultiplexer IC13 decodes digital signals that define the range and activates the solid-state switches on the highest instrument range.

4-17. The amplified 94 Hz signal is converted to a DC analog signal by means of a demodulator circuit that operates in synchronism with the chopper. The demodulator consists essentially of a sample-and-hold switch, composed of solid-state switches IC10b and IC10c and associated circuitry. Switches IC10b and IC10c are controlled by the 94 Hz drive signals from flip-flops IC8a and IC8b. The sampling point and period of the sample-and-hold circuit have been chosen to minimize switching products and noise and to vary signal averaging in accordance with the signal level. Switch IC9a adjusts operating parameters automatically in accordance with the instrument range; it is activated through gates IC11b and IC11c and demultiplexer IC13 on the four higher ranges.

4-18. The DC output voltage of the sample-and-hold circuit is amplified by integrated circuits A8, IC14, A9 and associated circuitry. Integrated circuit IC14 is a demultiplexer that decodes microprocessor-supplied digital signals that define the selected range and adjusts an attenuator circuit accordingly; the gain of the amplifier is 125, 12.5 or 1.25, depending upon the selected range. The full-scale output voltage of the amplifier is 2.5 volts nominal on each range.

4-19. The output voltage of integrated circuit A9 is usually unipolar and positive, however, during automatic zeroing, it may be positive or negative, depending upon small DC offsets. Because some of the following circuits operate only with unipolar signals, a polarity switch is required. This polarity switch, which consists of solid-state

switches IC3b and IC3c, operates under control of the microprocessor on the control printed circuit board, which tests for polarity. The DC voltage is routed through the polarity switch to the appropriate input of operational amplifier A3 so that the DC output from this amplifier is always negative. This negative output voltage is applied to a comparator circuit.

4-20. Comparator A2 operates in conjunction with the microprocessor on the control printed circuit board and D/A converter IC2 to convert the DC output signal of amplifier A3, which is proportional to the input RF voltage, to a digital signal that can be processed by the microprocessor. D/A converter IC2 is supplied with successive half-level digital signals (full-scale/2, full-scale/4, etc.) by the microprocessor. D/A converter IC2 converts these digital signals to a DC analog voltage that is supplied through amplifier A1 to comparator A2, where it is compared with the DC signal from amplifier A3. The difference signal from comparator A2 is supplied to the microprocessor through interface IC1 so that the microprocessor can monitor the results of the comparison and adjust the digital signal accordingly. The digital signal is adjusted by the microprocessor until the two input signals applied to comparator A2 are equal. The resulting digital signal then defines the DC level being measured. This digital signal is then processed (zero correction, unit conversion, etc.) by the microprocessor before application to the LED display circuits of the instrument.

4-21. After the digital signal has been fully processed by the microprocessor, it is supplied by the microprocessor to D/A converter IC2, which now converts the processed digital signal to a corresponding DC analog voltage that is used to drive the front-panel meter and the recorder output of the instrument. This DC analog voltage from D/A converter IC2 is supplied through amplifier A1 to sample-and-hold switch IC3a, which is closed at this time by a control signal from the microprocessor. The analog DC voltage from the sample-and-hold circuit is applied to the front-panel meter and the recorder output.

4-22. All interfacing between the input printed circuit board and the microprocessor is accomplished through interface IC1, an input/output device that operates under control of the microprocessor. When signal RD is activated by the microprocessor, data is transferred from the input printed circuit board to the microprocessor, provided that signal CS to interface IC1 is also active; when signals WR and CS are both activated by the microprocessor, data is transferred from the microprocessor to the input printed circuit board. Data flows between the input printed circuit board and the microprocessor over the eight-line bidirectional data bus. Routing of data through the interface is controlled by the address signals supplied to the interface by the microprocessor.

SECTION IV  
THEORY OF OPERATIONS

4-23. Control PC Board Circuits. Refer to Figure 4-3. Operation of the instrument is controlled by a microprocessor on the control printed circuit board. The control printed circuit board is organized around a central processing unit (CPU), associated memories, input/output ports and a 40-line bus. A stored program, in conjunction with key-entered commands, enables the microprocessor to perform a variety of functions, including the following:

- a. Analog to digital conversion
- b. Zero determination
- c. Zero correction
- d. Ranging
- e. Signal processing
- f. Binary to BCD conversion
- g. dB conversion
- h. dB reference conversion
- i. dB limit testing

4-24. Integrated circuit IC3 is the microprocessor CPU. It is an 8-bit unit that operates at a clock frequency of 2 MHz, generated by integrated circuits IC1a through IC1c and associated circuitry. The operating program for the microprocessor is stored in integrated circuits IC6 and IC7, which are programmable read-only memories (PROMs). RAM IC8 provides temporary storage of data during operation of the instrument. It also stores certain measurement parameters such as probe data, key-entered parameters, etc. Lithium-type battery BT1, which has an anticipated life of 10 years, supplies power to RAM IC8 during power-down of the instrument to enable retention of data in memory. During normal operation, RAM IC8 is powered by transistor Q1. Integrated circuit IC16 is an I/O port which interfaces with the following:

- a. An 8-bit switch used to set the mode of operation, number of channels and number of probes.
- b. A test socket (J3) used in signature analysis.
- c. A connector (P3) for output of status information.

4-25. The CPU receives and transmits data over an 8-line data bus. A 15-line bus is used for addressing and a control bus is used for various control functions. When the instrument is turned off, signal RESET is activated by the power supply circuits and the microprocessor is reset to the start of the operating program; when the instrument is next turned on and DC voltages have reached the correct operating levels, the RESET signal is deactivated by the power supply circuits and the microprocessor begins to execute the stored program instructions. Instructions are retrieved from storage by the CPU in accordance with the address code developed at its output. Decoder IC4 enables the appropriate PROM (IC6 or IC7) and the instruction contained in the memory location defined by the address on address lines A0 through A11 is read and transmitted to the CPU over the data bus. The CPU then executes this instruction.

4-26. During the measurement process, the CPU must retrieve data from storage and from the input and display printed circuit boards; it must store temporary calculation values; and it must output data to the input and display printed circuit boards. To retrieve data from memory, the storage device and memory location are defined by the address supplied by the CPU and signals  $\overline{MREQ}$  and  $\overline{RD}$  are activated. Integrated circuit IC4 decodes three of the address bits to activate signal  $\overline{CS}$  at RAM IC8 through gates IC9a and IC9c. Signal OE at RAM IC8 is activated through gate IC15d and data stored at the location specified by the remaining address bits are transmitted over the data bus to the CPU or to other circuits connected to the data bus. To access data developed by circuits outside the control printed circuit board, the CPU activates signals  $\overline{TORQ}$  and  $\overline{RD}$  along with the appropriate address lines. Decoder IC14 decodes three address bits to develop enabling signal  $\overline{CS}$  for interface IC16, integrated circuit IC18, or interface IC1 on the input printed circuit board, as specified by the three address bits; and gate IC15b activates signal  $\overline{RD}$  for the read function. If integrated circuit IC18 is enabled, keyed-in commands from the display circuit board, which had been stored in integrated circuit IC18, are transmitted over the data bus. If integrated circuit IC16 is enabled, input data from connector J3, bit switch S1 or power supply connector P4, as determined by address bits A0 and A1, is supplied through interface IC16 to the data bus. If interface IC1 on the input printed circuit board is enabled, data generated on the input printed circuit board is transmitted over the data bus through interface IC1.

4-27. To write data into memory, the CPU activates signal  $\overline{WR}$  and the address lines that define the storage device and storage location. Decoder IC4 decodes three address bits to enable signal  $\overline{CS}$  at RAM IC8, signal  $\overline{WR}$  enables the write function of RAM IC8 through inverter IC1d and gate IC9b, and data on the data bus is written into memory at the location specified by the remaining address lines. To output data to circuits outside the control printed circuit board, signal  $\overline{TORQ}$  is activated by the CPU in addition to the previously mentioned signals. Signals  $\overline{TORQ}$  and  $\overline{WR}$  activate the write enable signal to the device defined by the address bits. Decoder IC14 decodes three address bits to select the appropriate device (interface IC16, interface IC18 or interface IC1 on the input printed circuit board). Data on the data bus is then transferred to the selected device. If interface IC16 is selected, this data is transferred through interface IC16 to connector P3 or J3, as determined by address bits A0 and A1. The output to connector P3 consists of dB out-of-limit signals and an input-disconnect signal, which is activated when the automatic zeroing function is initiated. The output data on connector J3 is used in signature analysis checks. If interface IC18 is selected, the data on the data bus are written into storage in interface IC18 for application to the display printed circuit board. These data are subsequently

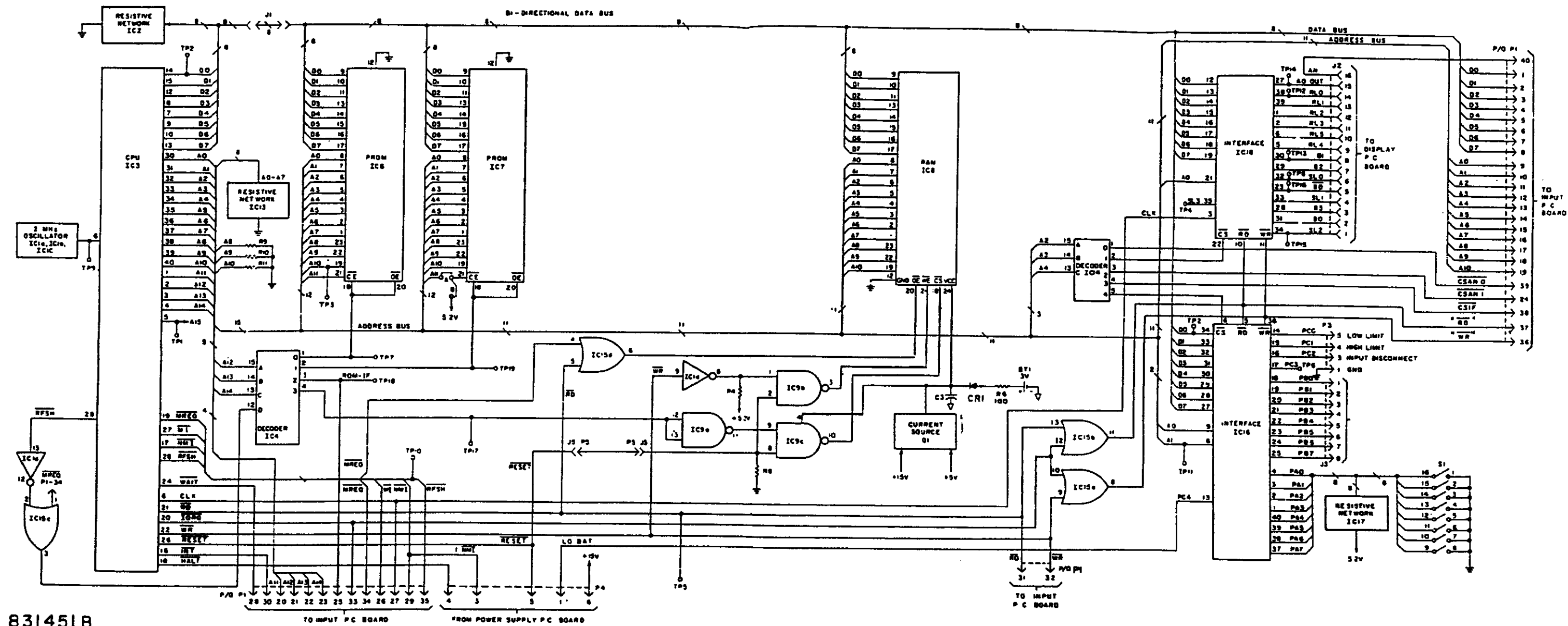

831451B

Figure 4-3. Control PC Board Detailed Block Diagram

4-27. (Continued).

clocked out of storage to activate the LED display and annunciators on the display printed circuit board. If interface ICI on the input printed circuit board is selected, data on the data bus are transferred through the interface to control various functions on the input printed circuit board.

4-28. Connector J1 is included in the data bus on the control printed circuit board to facilitate signature analysis checks of the microprocessor circuits. When connector J1 is pulled out, the data bus is disconnected from the CPU and the CPU executes successive NOPs for free-running signature analysis checks.

4-29. The CPU receives two control signals directly from the power supply printed circuit board. If the power supply voltage should drop during operation, or on equipment turn-off, signal **NMI** is activated by the power supply circuits; the CPU, on receipt of this signal, activates signal **HALT**, thereby halting further execution of the program. Signal **HALT** is applied back to the power supply printed circuit board, where it latches signal **RESET** in the active state. Signal **RESET**, in turn, causes the microprocessor to return to the starting point of the program. When the power supply voltage rises to a level approximately 150 millivolts below its nominal value, either as a result of correction of the undervoltage condition or of power turn-on, signal **RESET** is deactivated to permit execution of the stored program by the microprocessor.

4-30. Display PC Board Circuits. Refer to Figure 4-4. The display printed circuit board contains the instrument LED display, analog meter, annunciators, keyboard and control circuits for these items. It interfaces directly with the control printed circuit board. When any keyboard key is pressed, the microprocessor on the control printed circuit board interrupts the normal measurement process and accepts and stores the key-entered commands; the microprocessor also supplies digital data to the display printed circuit board to cause keyed-in numerical values to appear on the LED display. The microprocessor resumes the normal measurement process when any of the terminator keys (LIMITS dB, SELECT REF LEVEL dB) is pressed. Upon completion of the measurement by the microprocessor, measurement values are supplied to the display printed circuit board.

4-31. Operation of the display printed circuit board is controlled by the microprocessor through integrated circuit IC18 on the control printed circuit board, provides the following functions:

a. A RAM for storage of microprocessor output data to the display printed circuit board.

b. A first-in, first-out RAM which accepts and stores input information (up to 8 key commands) from the display printed circuit board.

c. Scan signals for both the LED display and the keyboard.

4-32. The LED display consists of four 7-segment displays, which provide a display capacity of four digits with decimal points and a fifth display which is capable of displaying a minus sign. Each display consists of individual anodes for each segment that makes up the display, the decimal point and a common cathode. The character that appears on the display is determined by the activated anodes at the time that the common cathode is scanned. The individual displays and the associated annunciators are scanned in sequence. The display duty cycle is 12.5%; that is, each digit or annunciator of the instrument is on 12.5% of the time.

4-33. Digital information for the LED display and annunciators is developed by the microprocessor and is stored in the output RAM contained in integrated circuit IC18 on the control printed circuit board. Digital information that defines display and annunciator row selection is supplied to 8-channel demultiplexer IC2. The output lines of demultiplexer IC2 are activated in sequence, based on the input digital codes. The signal on the active output line of demultiplexer IC2 is applied through resistive network IC5 to display driver IC7 and the display driver supplies driving power for the corresponding display and the corresponding annunciator row. At the same time, digital data that define the display segments and annunciators that are to be activated are supplied to decoder IC1. The binary-coded input is decoded by decoder IC1 and the output lines of the decoder are activated in accordance with this decode. The outputs of the decoder activate the individual anodes of the selected display and the individual annunciators in the active annunciator row, thereby providing the appropriate instrument display. A decimal-point signal is applied through transistor Q1, when appropriate, to cause a decimal point to be displayed to the right of the character on the active display.

4-34. Demultiplexer IC2 also supplies scanning signals to the keyboard. As each of its first five output lines is activated in sequence, a scan signal is applied to an individual row of the keyboard through an inverter. If any key in the row being scanned is pressed, a signal is supplied to one of the column output lines to the RAM in integrated circuit IC18 on the control printed circuit board and the key command is stored in the RAM. Key selection is defined by a combination of the row scan signal and the column output line. The RAM can store up to a maximum of eight key commands and it delivers this stored information to the microprocessor when it is read. Actuation of more than eight key commands without a read causes the RAM to be cleared.

## SECTION IV THEORY OF OPERATIONS

4-35. Analog DC voltage proportional to the measured RF voltage level is supplied from the control printed circuit board to the front-panel meter to provide a relative indication of measured RF voltage for peaking and nulling applications. The DC analog voltage is also supplied to rear-panel connector P1. This signal can be used to drive an external recorder.

4-36. Power Supply Circuits. Refer to Figure 4-5. Power supply printed circuit board A7 performs the following functions:

a. Converts 100, 120, 220 or 240 volt, 50 to 400 Hz, AC line power to +5, +5.2, -5, +15 and -15 volt DC for system operation.

b. Generates a power-up signal for the microprocessor when supply voltage levels reach the proper values for system operation.

c. Activates an interrupt signal to the microprocessor when supply voltage levels drop to values too low for reliable operation.

4-37. Input AC line power is supplied to the primary of power transformer T1 on the main chassis through fuse F1, LINE switch S1 and a voltage-selector printed circuit card. The voltage-selector printed circuit card provides a convenient way to change the primary winding connections of power transformer T1 to accommodate the various AC line voltages.

4-38. Power transformer T1 steps down the AC line voltage. Two separate secondary windings drive bridge rectifiers CR1 and CR2.

The DC output voltage of rectifier CR1 is filtered by capacitors C1 and C2, and is then supplied to regulators IC2 and IC3, which develop +15 volts and -15 volts DC, respectively. A regulated -5 volt output is derived from the regulated -15 volt supply by regulator IC5. The DC voltage developed by rectifier CR2 is filtered by capacitor C3 and drives regulator IC4 to develop the +5.2 volt DC output. Potentiometer R5 provides means for adjusting the +5.2 volt output.

4-39. The raw +15 volt DC supply also drives regulator IC1, which produces +5 volts to power integrated circuits A1 and IC6 and generate a DC reference voltage at the junction of resistors R7 and R8. Comparator A1a monitors the output voltage of the +5.2 volts regulated supply to develop a power-up signal on turn-on and an interrupt signal for under-voltage or power-down conditions. When the instrument is turned on, comparator A1a develops a positive output pulse when the output voltage of the +5.2 volts regulated supply reaches a level approximately 150 millivolts below the nominal output voltage. This positive pulse clocks flip-flop IC6 to deactivate signal RESET to the microprocessor on the control printed circuit board. When the output voltage of the +5.2 volts regulated supply drops below the reliable usable level during instrument operation or during instrument shutdown, comparator A1a switches its output level to a logic low, thereby activating signal NMI to the microprocessor. The microprocessor then activates signal HALT, which reset flip-flop IC6, thereby latching signal RESET low to ensure resetting of the microprocessor to the start of its program.

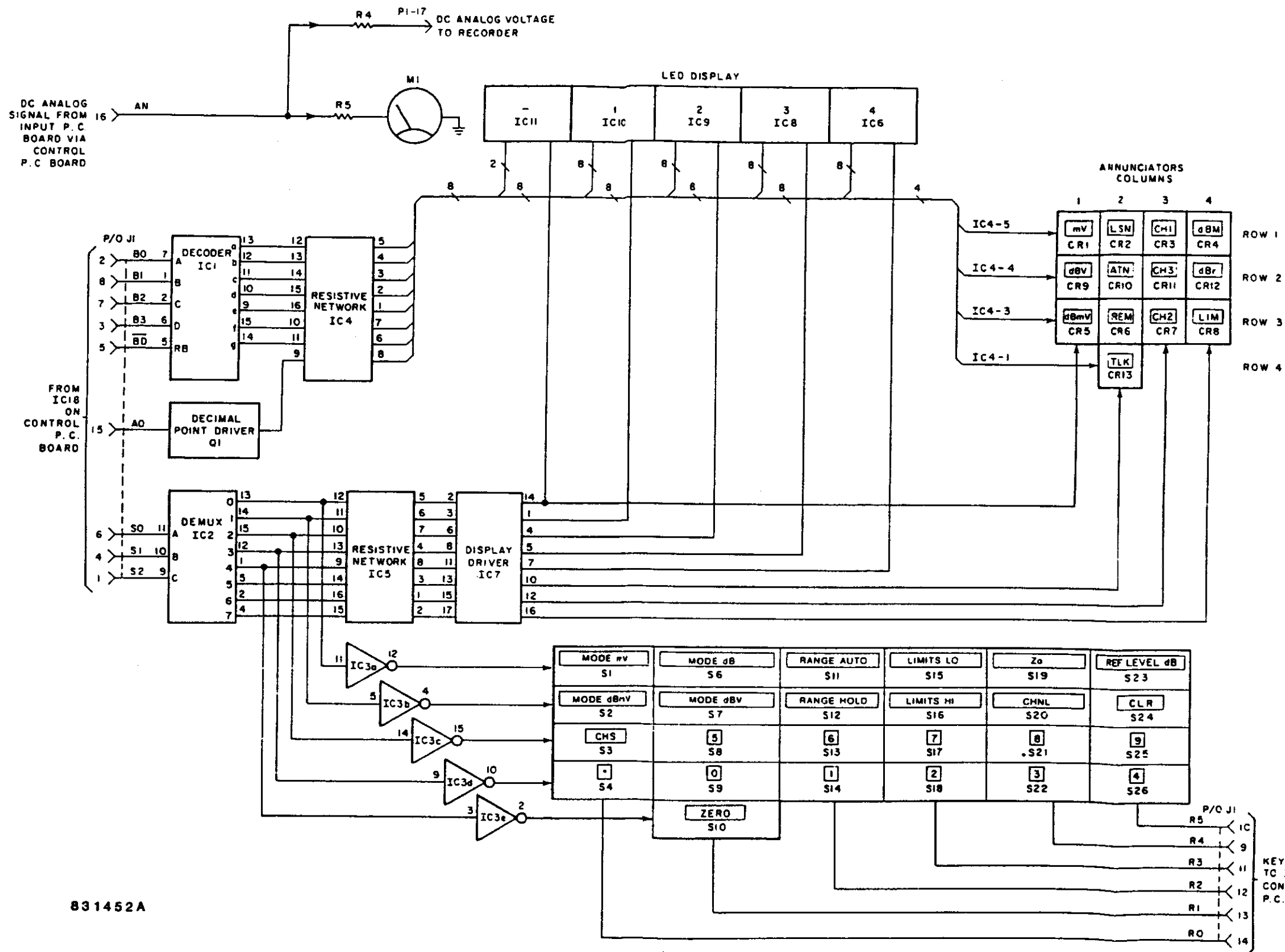

831452A

Figure 4-4. Display PC Board Detailed Block Diagram

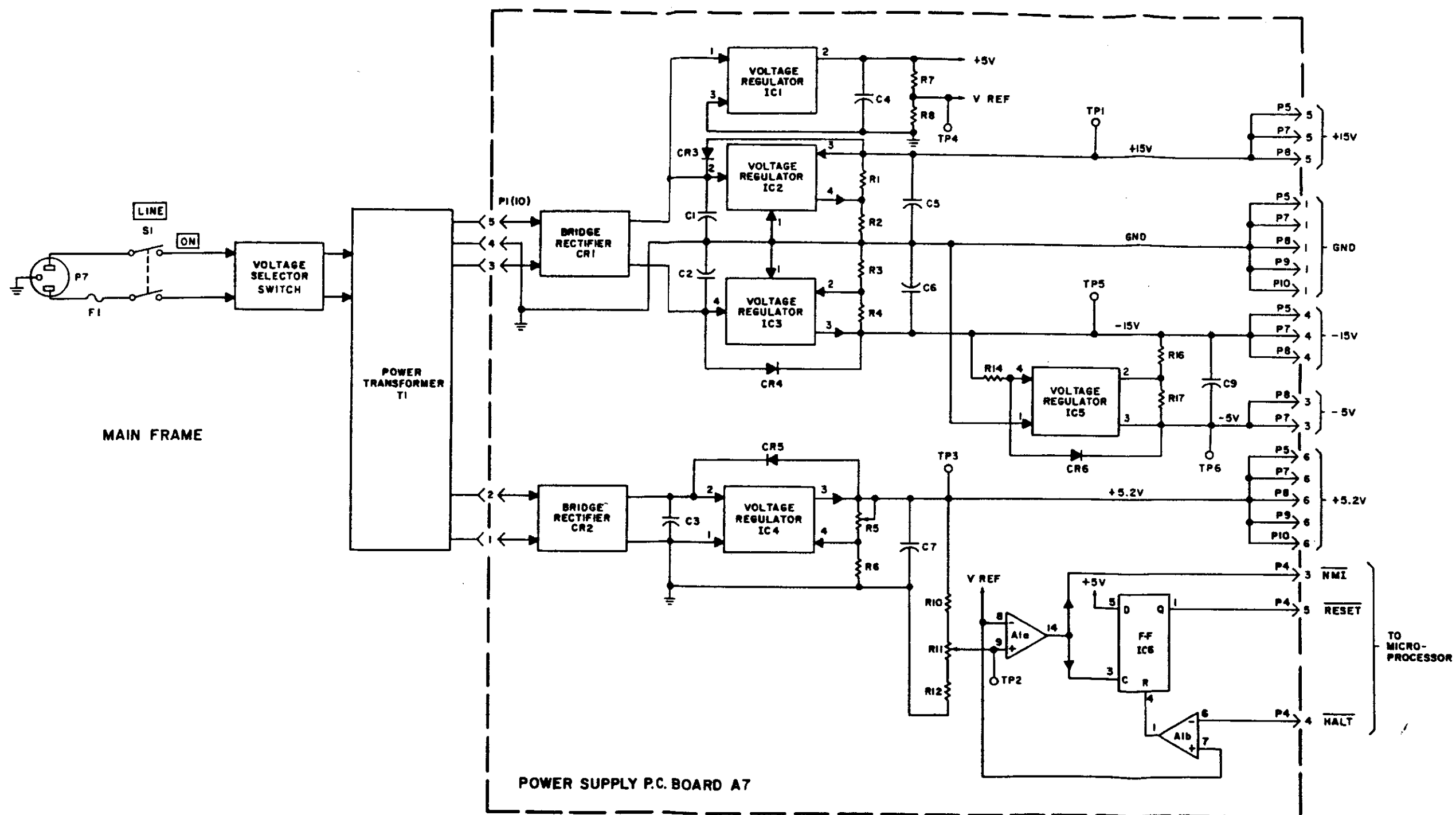

831453A

Figure 4-5. Power Supply PC Board  
Detailed Block Diagram

SECTION V  
MAINTENANCE

## 5-1. INTRODUCTION

5-2. This section contains the safety requirements, test equipment required, cleaning procedures, removal and replacement procedures, inspection procedures, performance tests, adjustment procedures, and troubleshooting for the Model 9200B.

## 5-3. SAFETY REQUIREMENTS

5-4. Although this instrument has been designed in accordance with international safety standards, general safety precautions must be observed during all phases of operation and maintenance of the instrument. Failure to comply with the precautions listed in the Safety Summary located in the front of this manual could result in serious injury or death. Service and adjustments should be performed only by qualified service personnel.

## 5-5. TEST EQUIPMENT REQUIRED

5-6. Test equipment required for the performance tests, adjustments, and troubleshooting is listed in Table 5-1.

## 5-7. CLEANING PROCEDURE

5-8. Cleaning. Painted surfaces can be cleaned with a commercial, spray-type window cleaner or with a mild soap and water solution.

**CAUTION**

Avoid the use of chemical cleaning agents which might damage the plastics used in the instrument. The recommended cleaning agents is a solution of 1% mild detergent and 99% water.

5-9. REMOVAL AND REPLACEMENT PROCEDURES  
Refer to Figure 5-1 and 5-2.

5-10. Instrument Covers. Remove the instrument covers as follows:

- a. Disconnect the power cord and all signal cables from the instrument.
- b. Remove the two screws located at the rear of the cover.
- c. Slowly lift the cover up and to the rear.
- d. Turn the instrument over and remove the bottom cover in the same manner as the top cover was removed.
- e. To replace the covers reverse the removal procedure.

5-11. Non-Volatile RAM Cell Replacement. Refer to Figure 5-3. The replacement time for the cell is expected to be 10 years from the time of manufacture. This is the shelf life of the cell. If the cell replacement is

needed, restoration of all instrument calibration data will be required. Replace the cell as follows:

**CAUTION**

Use care to avoid shorting the leads of the replacement cell. Shorting will cause discharge of the cell and result in reduced cell lifetime.

- a. Remove all power from the instrument.
- b. Remove the instrument covers.
- c. Remove the control printed circuit board from the instrument.
- d. Remove the insulating shields from the non-volatile RAM section.
- e. Disconnect the positive lead of the defective cell by cutting the lead.
- f. Unsolder the defective cell using a low-wattage soldering iron and remove excess solder from the mounting holes.
- g. Install the replacement cell, observing cell polarity.
- h. Solder the negative terminal of the cell first. Then, as quickly as possible, solder the positive terminal.
- i. Check the non-volatile RAM current by measuring the voltage across resistor R6. The voltage should be less than 525 microvolts.
- j. Measure the voltage at pin 24 of integrated circuit IC8. This voltage should be approximately 3 volts.
- k. Reassemble the shields on the control printed circuit board. Install the control printed circuit board in the instrument.

l. Replace the instrument covers.

## 5-12. INSPECTION

5-13. If an equipment malfunction occurs, perform a visual inspection of the instrument. Inspect for signs of damage caused by excessive shock, vibration, or overheating, such as broken wires, loose hardware and parts, loose electrical connections, electrical shorts, cold solder connections, or accumulations of dirt and other foreign matter. Correct any problems discovered, then perform the performance tests to verify that the instrument is operational. If a malfunction persists or the instrument fails any of the performance tests, refer to the adjustment procedures. After the instrument has been adjusted, perform the performance tests again to verify instrument operation. If the instrument can not be adjusted, or fails the performance tests refer to the troubleshooting procedure.

SECTION V  
MAINTENANCE

TABLE 5-1. MAINTENANCE TEST EQUIPMENT		
EQUIPMENT	SPECIFICATIONS	SUGGESTED MODEL
Signal Generator	AM - FM, 0.15 to 520 MHz, -50 to +19 dBm	Boonton Electronics Model 1020
Digital Multimeter	4 1/2 Digit $\pm 0.08\%$ rdg	Data Precision 1450
Oscilloscope	100 MHz Dual Channel	Hewlett-Packard 1740A
RF Millivoltmeter Calibrator	60 $\mu$ V to 3000 mV Uncertainty $\leq \pm 0.5\%$ rdg	Boonton Electronics Model 26A
Signature Analyzer	Start, stop, clock inputs, data probe, max clock freq 10 MHz	Hewlett-Packard 5004A
Controller		Hewlett-Packard HP9825 or HP 85
Calibration Tape and Diagnostic ROM Kit		Boonton Electronics
Range Calibrator	9 $\mu$ V to 4.5 V $\pm 0.15\%$	Boonton Electronics Model 2500
NOTE		
The following additional items are required for only for RF probe SWR and frequency response checks.		
Signal Generator:		
125 kHz to 175 MHz	AM/FM .125 to 175 MHz -130 to +23 dBm	Boonton Electronics Model 103C/D
450 kHz to 520 MHz	AM/FM .45 to 520 MHz -130 to +13 dBm	Boonton Electronics Model 102E/F
10 MHz to 1400 MHz	1 to 1400 MHz, 200 kHz to 500 MHz Sweep width 50s -80 to +10 dBm	Wavetek Model 2001
Slotted Line Detector		General Radio 900 LB  Boonton Electronics Model 9200B
Power Splitter		Weinschel Model 1870A or Hewlett-Packard 11850A
Calibrated RF Microwattmeter	-60 to +10 dBm 100 kHz to 18 GHz, 1.2% rdg	Boonton Electronics Model 4200
Sweep Generator		Wavetek 2001
SWR Autotester	10-4000 MHz 50 $\Omega$ 40 dB directivity	Wiltron 63N50
Oscilloscope	DC to >2 MHz Horz & Vert Bandwidth 50 $\mu$ V to 5 V/Div $\pm 2\%$ DC to 1 MHz	Tektronix 5110 (with two 5A20 vertical amplifiers
Standard 1.2:1 Mismatch	DC to 18 GHz 1.20 $\pm$ .10 max	Maury 2562C

## 5-14. PERFORMANCE TESTS

5-15. The performance tests should be performed about every 12 months or after the instrument has been repaired. The performance tests may also be performed when the instrument is first received to verify performance.

## 5-16. Preliminary Setup.

a. Turn on the instrument and calibrator and allow sufficient warmup time. If either unit had been stored at ambient temperatures substantially different from the ambient temperature at the test facility, make sure enough time is allowed for each device to reach ambient temperature.

b. A 1 MHz low-impedance voltage calibration source, such as the Boonton Electronics Corporation Model 26A RF Millivoltmeter Calibrator and a DC voltmeter or oscilloscope capable of measuring 0 to +10 volts is required.

c. The Model 26A RF Millivoltmeter Calibrator is designed to operate into a high impedance load, such as the Model 952001 RF Probe. If the instrument is fitted with the Model 952009 RF Sensor, which has a built in 50  $\Omega$  termination, it will be necessary to modify the output circuit of the Model 26A, as follows:

1. Disconnect AC power to the Model 26A.
2. Remove the bottom cover by removing the securing screw at the rear and then sliding the cover to the rear.
3. Remove the TNC-50  $\Omega$  termination from the tee adapter at the output of the calibrator.
4. Replace the cover, re-power and proceed as follows:
  - d. Set the calibrator output to zero. Attach the channel 1 RF probe to the front panel SENSOR connector on the instrument and connect the probe input to the calibrator using an open circuit BNC Model 91-6G adapter supplied with the calibrator.
  - e. Key in the following measurement parameters through the instrument keyboard:
 

```
1 SELECT CHNL
1 PROBE (SENS)
MODE mV
0 REF LEVEL dB
```

## NOTE

Maintain the measurement parameters specified above for each of the following tests unless specifically directed otherwise.

## 5-17. Automatic Zero Function Test.

5-18. Check the automatic zeroing function of the instrument, proceed as follows:

a. Ascertain that the signal input to the probe is zero. (Press the white 0 key on the calibrator.)

b. Press the ZERO key on the instrument and ascertain that the following results are obtained:

1. The logic signal level at pin 3 of rear-panel connector P3 should switch from a logic low to a logic high when the ZERO key is pressed. It should remain high throughout the zeroing period and it should return to a logic low at the end of the zeroing period.

2. The instrument display should display cccc for approximately 18 seconds after the ZERO key is pressed. At the end of the zeroing period, the display should show cc 3 for all dB modes, or a residual reading for the mV mode.

## NOTE

In the mV mode, the residual reading after zeroing is composed of random noise and residual offsets. It should ideally show plus and minus excursions of less than 100 counts.

## 5-19. Autoranging Mode Test.

5-20. Check the autoranging function of the instrument, set the calibrator to each of the values listed below and ascertain that the instrument display agrees with each input level within  $\pm 2\%$ :

3000 mV	30 mV
1000 mV	10 mV
300 mV	3 mV
100 mV	1 mV

## 5-21. Basic Instrument Accuracy Test.

5-22. Check the basic accuracy of the instrument, proceed as follows:

- a. With zero input to the probe (white 0 button on the calibrator pressed), zero the instrument by pressing the ZERO key.
- b. Press the MODE mV key after zeroing has been completed.
- c. Set the output level of the calibrator to each of the following full-scale levels in succession and ascertain that the instrument display agrees within the accuracy shown:

## Full Scale Values

Voltage Levels	Accuracy of Indication
3000 mV	$\pm 1\% \pm 1$ count $\pm$ calibrator uncertainty
1000 mV	$\pm 1\% \pm 1$ count $\pm$ calibrator uncertainty
300 mV	$\pm 1\% \pm 1$ count $\pm$ calibrator uncertainty
100 mV	$\pm 1\% \pm 1$ count $\pm$ calibrator uncertainty
30 mV	$\pm 1\% \pm 1$ count $\pm$ calibrator uncertainty
10 mV	$\pm 1\% \pm 1$ count $\pm$ calibrator uncertainty
3 mV	$\pm 1\% \pm 1$ count $\pm$ calibrator uncertainty
1 mV	$\pm 2\% \pm 2$ count $\pm$ calibrator uncertainty

d. Set the output level of the calibrator to 1000 millivolts. Then, set the output level of the calibrator to each of the following values in succession and ascertain that the instrument display agrees with the applied level within the tolerance shown.

SECTION V  
MAINTENANCE

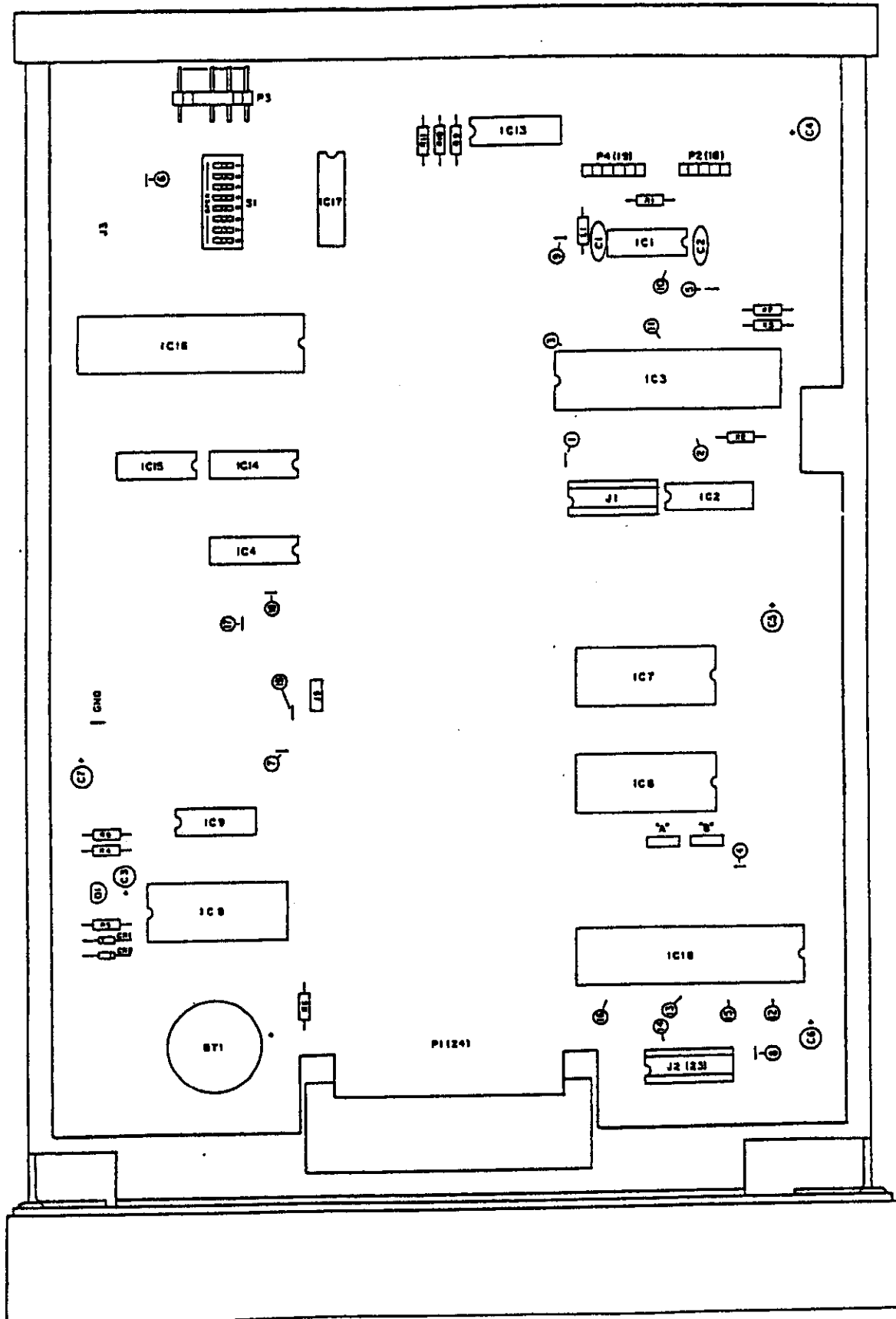

Figure 5-1. Instrument, Top inside view.

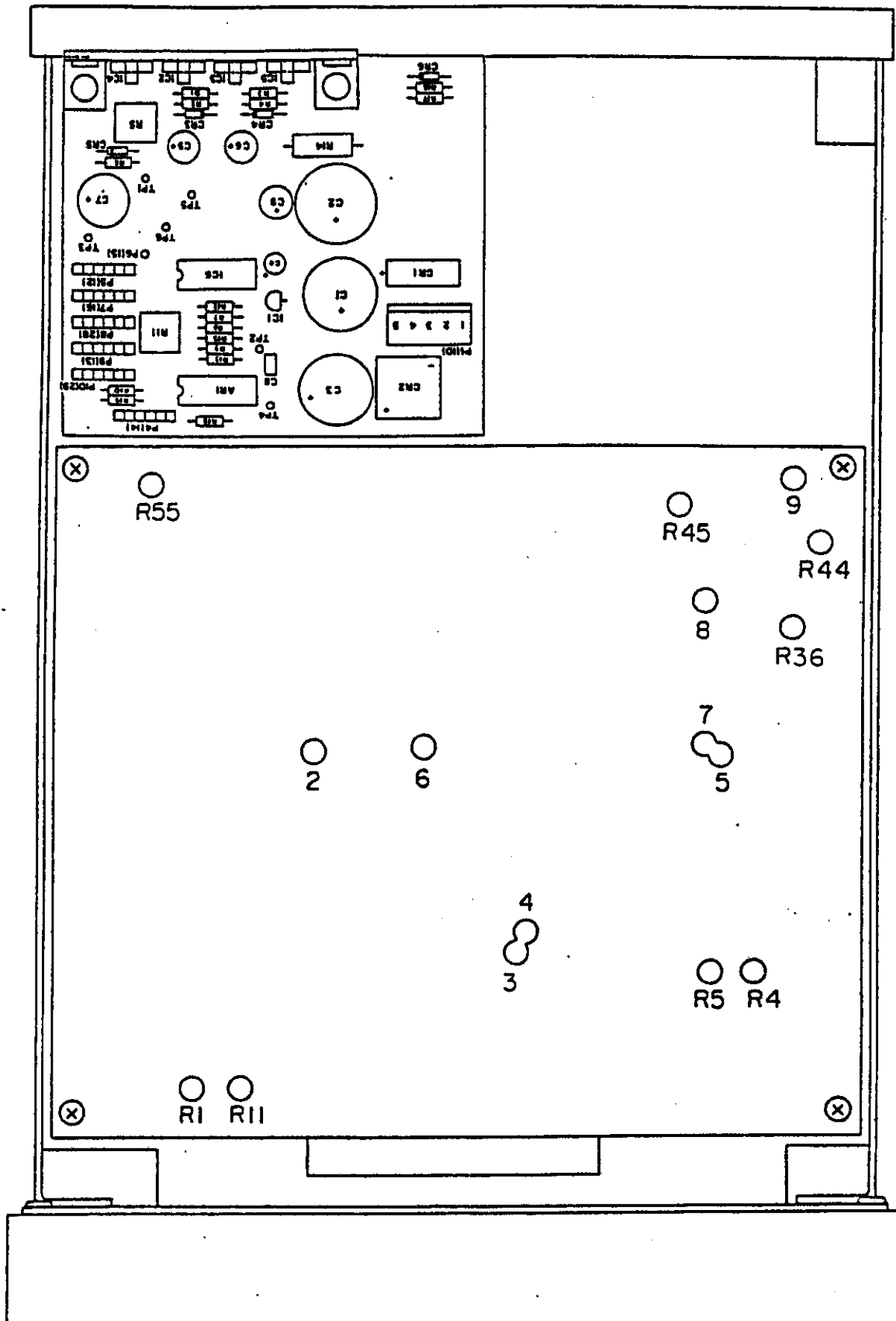

Figure 5-2. Instrument, Bottom inside view.

**SECTION V  
MAINTENANCE**

5-22. (Continued).

**Downscale Values**

Voltage Levels	Accuracy of Indication
1000 mV	$\pm 1\%$ $\pm 1$ count $\pm$ calibrator uncertainty
900 mV	$\pm 1\%$ $\pm 1$ count $\pm$ calibrator uncertainty
800 mV	$\pm 1\%$ $\pm 1$ count $\pm$ calibrator uncertainty
700 mV	$\pm 1\%$ $\pm 1$ count $\pm$ calibrator uncertainty
600 mV	$\pm 1\%$ $\pm 1$ count $\pm$ calibrator uncertainty
500 mV	$\pm 1\%$ $\pm 1$ count $\pm$ calibrator uncertainty
400 mV	$\pm 1\%$ $\pm 1$ count $\pm$ calibrator uncertainty
300 mV	$\pm 1\%$ $\pm 1$ count $\pm$ calibrator uncertainty

5-23. dB Mode Check.

5-24. Check the dB modes of operation as follows:

a. Press the following keys:

1 (or 2) SELECT CHNL  
MODE mV  
50 SELECT Z<sub>0</sub>  
0 REF LEVEL dB

b. Set the calibrator output to 1000 mV. The indication on the instrument display should be 1000 mV  $\pm 2\%$ .

c. Press the MODE dBmV key. The indication on the instrument display should be 60.00  $\pm 0.18$  dBmV.

d. Press the MODE dBV key. The indication on the instrument display should be 00.00  $\pm 0.18$  dBV.

e. Press the MODE dBm key. The indication on the instrument display should be 13.01  $\pm 0.18$  dBm.

5-25. dB Reference Level Function Test.

5-26. Check the dB reference level function as follows:

a. Set the output level of the calibrator to 1000 mV.

b. Press the MODE dBm key and ascertain that the instrument display indicates approximately 13 dB.

c. Enter a +13 dB reference level by pressing the following keys:

1  
3  
REF LEVEL dB

d. Ascertain that the instrument display now indicates approximately 0 dBm. Both the dBm annunciator and the dBm annunciator should be lighted.

e. Reset the instrument to indicate dBm by pressing the following keys:

0 (or CLR)  
REF LEVEL dB

f. Ascertain that the instrument display again indicates approximately 13 dB. The dBm annunciator should be lighted and the dBm annunciator should be off.

5-27. Non-Volatile RAM Cell Test.

5-28. Test the Non-Volatile RAM cell as follows:

**CAUTION**

The following test procedure must be adhered to strictly; otherwise, instrument data stored in the non-volatile memory will be lost. Do not attempt to take measurements other than those specified. Take all necessary precautions to ensure that no terminals are shorted to another terminal or to common (ground).

**NOTE**

The load imposed on the cell by the non-volatile RAM is 5.25  $\mu$ A or less. With this load, the cell has a rated life of at least 100,000 hours, which is greater than 10 years.

a. Secure power and remove covers.

b. Connect a digital multimeter between the cell positive terminal and ground, ensuring that the cell is not shorted to ground at any time.

c. Observe the digital multimeter indication; it should be approximately 3 volts with input power to the instrument turned off. If the indications is much lower than 3 volts, replace the cell in accordance with the procedures in paragraph 5-11.

5-29. Probe SWR and Frequency Response Tests.

5-30. The RF probe and probe accessories used with the instrument can be checked for SWR and frequency response using the procedures in the following paragraphs. If an RF probe should exhibit out-of-tolerance performance in these tests, do not attempt to repair the probe; return it to the factory for repair or adjustment.

5-31. SWR Test.

5-32. Perform the test as follows:

a. Connect a slotted line to a signal source of the desired frequency range, and terminate the slotted line with the accessory device to be tested (i.e., Model 952003 50  $\Omega$  N Tee Adapter and Model 952014 50  $\Omega$  N Termination, or Model 952002 50  $\Omega$  BNC Adapter).

b. Connect the RF probe and RF voltmeter to the accessory being tested. The RF probe supplies a perturbation for which the accessory has been designed and the RF voltmeter permits the test level to be set to the desired value.

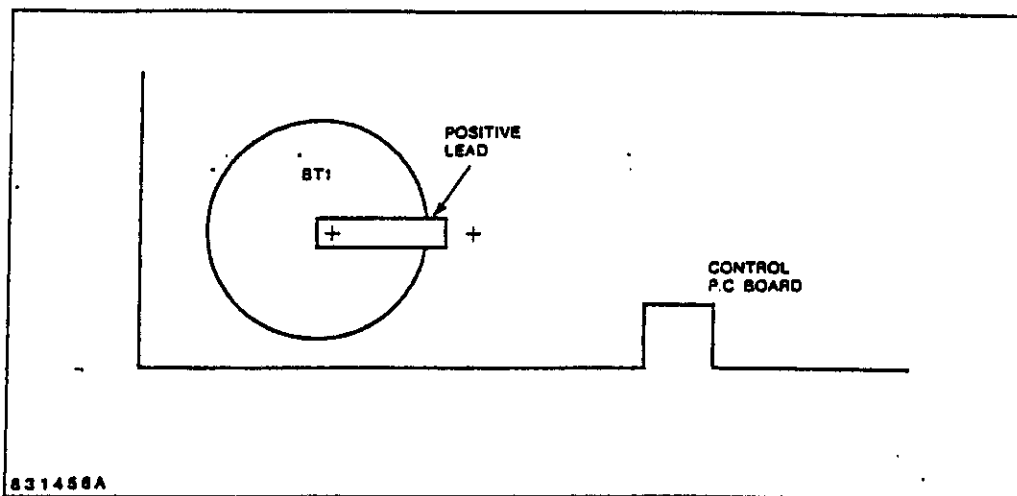

Figure 5-3. Non-Volatile RAM Cell Test and Connection Points.

5-31. (Continued).

c. Move the carriage of the slotted line to a point of minimum voltage, then to a point of maximum voltage. Record the minimum and maximum voltage values.

d. The SWR is the ratio of the maximum and minimum voltages.

e. Repeat the SWR measurement at other frequencies and levels, as required.

5-32. Frequency Response Tests.

5-33. The most accurate method of measuring the frequency response of the RF probe is through use of micropotentiometers, electrothermic AC-DC transfer instruments and attenuator-thermoelement voltmeters. Users who have such instruments available will be familiar with their use. Another method, with an accuracy compatible with the accuracy of the instrument, uses a point-by-point frequency scan in conjunction with a power splitter and calibrated RF microwattmeter. To use this method, proceed as follows:

a. Connect the equipment as shown in Figure 5-5.

b. Set the frequency of the signal generator to 10 MHz, and adjust the signal generator output to the desired test level. If the response is to be measured at only one level, a test voltage of 100 millivolts is recommended.

c. Disable the output of the signal generator momentarily and zero the RF microwattmeter.

d. Restore the signal generator output level and note the reading on the RF microwattmeter. Record the frequency of the signal generator and the indication on the RF millivoltmeter.

e. Change the signal generator output frequency, in whatever increments are desired, through the range of 10 to 1200 MHz, holding the reference reading on the RF microwattmeter constant. Record the frequency and RF millivoltmeter indication for each test frequency.

f. Reverse the output ports of the power splitter and repeat steps b through e.

g. Average the two readings obtained for each test frequency to obtain the correct RF voltmeter reading.

h. Further refinements can be made by filtering the output of the signal generator and measuring the complex reflection coefficients of the RF microwattmeter, accessory under test and all ports of the power splitter. The usual corrections can then be made. These procedures are not usually necessary and should be performed only if the additional accuracy is warranted.

5-34. Alternate Frequency Response and SWR Test Procedure.

5-35. An alternate method of measuring both the frequency response and SWR (in terms of the reflection coefficient), with somewhat reduced accuracy, uses a sweep generator, SWR bridge, external leveling of the generator, power splitter and sensitive oscilloscope. Perform the procedure as follows:

a. Connect the equipment as shown in Figure 5-5.

b. Disconnect the RF probe cable from the oscilloscope and connect it temporarily to an RF millivoltmeter. Adjust the output control of the sweep generator to provide an RF millivoltmeter indication of 100 millivolts at a fixed frequency of 100 MHz. Then, restore the original RF probe connection to the oscilloscope.

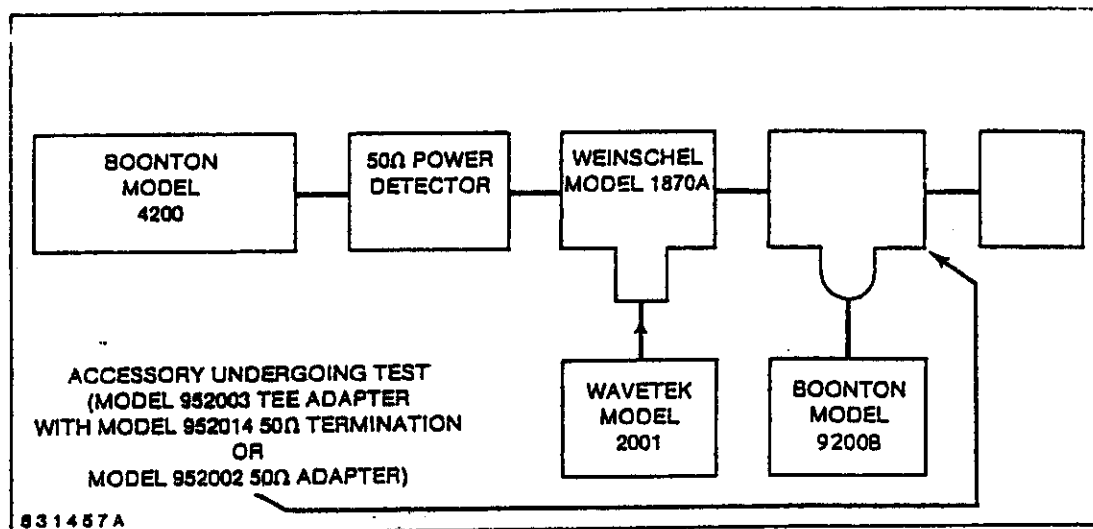

Figure 5-4. RF Probe Frequency Response Test Setup.

5-35. (Continued).

c. Calibrate one of the vertical input amplifiers of the oscilloscope for a sensitivity of 100 microvolts per division. Calibrate the other vertical input amplifier so that a change from 100 millivolts to 90 millivolts applied to the input of the RF probe under test will produce a vertical deflection of 1 division. This can be done easily with a Boonton Model 26A RF Millivoltmeter Calibrator; connect the RF probe temporarily to the output of the RF millivoltmeter calibrator, adjust the output of the RF millivoltmeter calibrator to 100 millivolts and 90 millivolts alternately and adjust the sensitivity of the second vertical amplifier for a deflection of 1 division.

d. The SWR channel may be zeroed with a 50Ω termination ( $SWR < 1.02$ ) before connecting the mismatch termination. Substitute the standard 1.2:1 mismatch termination for the accessory under test and calibrate the graticule of the oscilloscope for the SWR of 1.2. Reconnect the accessory and probe.

e. Adjust the limits on the three bands of the sweep generator for coverage from 10 to 1200 MHz. Study the traces of both the frequency-response and SWR (return loss).

f. Reverse the output ports of the power splitter and repeat steps d and e.

g. Note that the permissible error for the frequency response trace expands with frequency. For the most meaningful results, mark the graticule with a grease pencil to show the maximum permissible errors for the various frequency bands, as determined with a calibrated signal of 1 MHz, and at levels above and below the selected test level. Note also that the recovered DC from the RF

probe, which is applied to the second vertical input amplifier, will vary as the square of the RF input level for test levels of 30 millivolts or less. Above 30 millivolts, RF to DC conversion gradually changes from square law to linear and approaches a peak-to-peak rectifier at an input of 3 volts.

5-36. ADJUSTMENTS

5-37. Power Supply Adjustments.

5-38. Perform the adjustments as follows:

a. Connect the digital voltmeter between common and test point TP3. The voltage indication should be  $5.20 \pm 0.002$  volts. Adjust potentiometer R5 on the power supply board as required to obtain the specified indication.

b. Connect the digital voltmeter between test points TP2 and TP4. The voltage indication should be  $150 \pm 10$  millivolts. (The polarity of the reading will depend on how the test probes are connected.) Adjust potentiometer R11 on the power supply board as required to obtain the specified indication.

c. Connect the digital voltmeter between test point TP1 and common. The voltage indication should be  $+15 \pm 0.6$  volts.

d. Connect the digital voltmeter between test point TP5 and common. The voltage indication should be  $-15 \pm 0.6$  volts.

e. Connect the digital voltmeter between test point TP6 and common. The voltage indication should be  $-5 \pm 0.2$  volts.

5-39. Input Module Calibration and Adjustments.



**SECTION V  
MAINTENANCE**

5-42. (Continued).

- b. Set 2500 to RANGE 0, depress 0, dBV, allow instrument time to settle, 18.43, mode dBmV, AVERAGE SELECT, REF LEVEL dB.
- c. Set 2500 to RANGE 1, depress 1, dBV, settle, AVERAGE SELECT, REF LEVEL dB.
- d. Set 2500 to RANGE 2, depress 2, dBV, settle, AVERAGE SELECT, REF LEVEL dB.
- e. Set 2500 to RANGE 3, depress 3, dBV, settle, AVERAGE SELECT, REF LEVEL dB.
- f. Set 2500 to RANGE 4, depress 4, dBV, settle, AVERAGE SELECT, REF LEVEL dB.
- g. Set 2500 to RANGE 5, depress 5, dBV, settle, AVERAGE SELECT, REF LEVEL dB.
- h. Set 2500 to RANGE 6B, depress 6, dBV, settle, AVERAGE SELECT, REF LEVEL dB.
- i. Remove 2500. Set control board bit switch to OPERATE MODE.

5-43. AC Calibration.

5-44. The AC calibration procedure consists of the following: channel selection, probe selection, shaping table selection and three adjustments for each range. Perform the adjustment as follows:

- a. Connect the probe to the Model 26A Calibrator and allow both the calibrator and the Model 9200B to warm up for at least one-half hour. Depress the ZERO button on the Model 26A. On the Model 9200B, select Channel 1 or Channel 2, as required and probe number.

**NOTE**

When calibrating the Model 952009 sensor, the internal 50Ω shunt on the output of the Model 26A Calibrator must first be disconnected.

- b. Select the proper shaping table by setting the bit switch Figure (4-3) to CALIBRATE MODE 2 and pressing 0, SELECT Z<sub>0</sub>, for Model 952001 High Impedance Probe; or 1, SELECT Z<sub>0</sub>, for Model 952009 50Ω Voltage Probe. Leave the control board bit switch in CALIBRATE MODE 2 for subsequent operations.

**NOTE**

The result of any adjustment or correction can be determined at any time by returning the control board bit switch to the OPERATE MODE and pressing MODE mV keys. Return to CALIBRATE MODE 2 if further calibration is to be done.

- c. Clear previous midscale and downscale corrections by pressing:

0 MODE dBV, 0, MODE dBw, 0,  
MODE X100 (CLEARS RANGE 0)

1 MODE dBV, 0, MODE dBw, 0,  
MODE X100 (CLEARS RANGE 1)

2 MODE dBV, 0, MODE dBw, 0,  
MODE X100 (CLEARS RANGE 2)

3 MODE dBV, 0, MODE dBw, 0,  
MODE X100 (CLEARS RANGE 3)

4 MODE dBV, 0, MODE dBw, 0,  
MODE X100 (CLEARS RANGE 4)

5 MODE dBV, 0, MODE dBw, 0,  
MODE X100 (CLEARS RANGE 5)

6 MODE dBV, 0, MODE dBw, 0,  
MODE X100 (CLEARS RANGE 6)

**NOTE**

Pressing N and then MODE dBV selects range N. Pressing 0 and then MODE dBw clears midscale correction. Pressing 0 and then MODE X100 clears downscale correction.

- d. Zero the Model 9200B by pressing 0, MODE dBV, MODE mV, ZERO. Wait for the completion of the zeroing process (digit display blanks, then returns). If the zero indication is not less than ±50 counts, repeat zero until this is obtained. In step e which follows, the instrument should be re-zeroed, if necessary, just prior to adjusting each of the three lowest ranges.

- e. To adjust the full scale gain, set the Model 26A and 9200B as follows:

MODEL 26A	MODEL 9200B	MODEL 9200B DISPLAY
0.7 mV	0,MODE dBV, 7,,0,0,MODE dBmV, (WAIT) [1], AVERAGE SEL, REF LEVEL dB	≈5000 [2]
2.1 mV	1,MODE dBV, 2,1,,0,0,MODE dBmV, (WAIT), AVERAGE SEL, REF LEVEL dB	≈5000
7 mV	2,MODE dBV, 7,0,,0,0,MODE dBmV, (WAIT), AVERAGE SEL, REF LEVEL dB	≈5000
24 mV	3,MODE dBV, 2,4,,0,0,MODE dBmV, (WAIT), AVERAGE SEL, REF LEVEL dB	≈5000
100 mV	4,MODE dBV, 9,9,,9,9,MODE dBmV, (WAIT), AVERAGE SEL, REF LEVEL dB	≈5000
700 mV	5,MODE dBV, 7,0,,0,0,MODE dBmV, (WAIT), AVERAGE SEL, REF LEVEL dB	≈5000
3000 mV	6,MODE dBV, 3,0,,0,0,MODE dBmV, (WAIT), AVERAGE SEL, REF LEVEL dB	≈5000

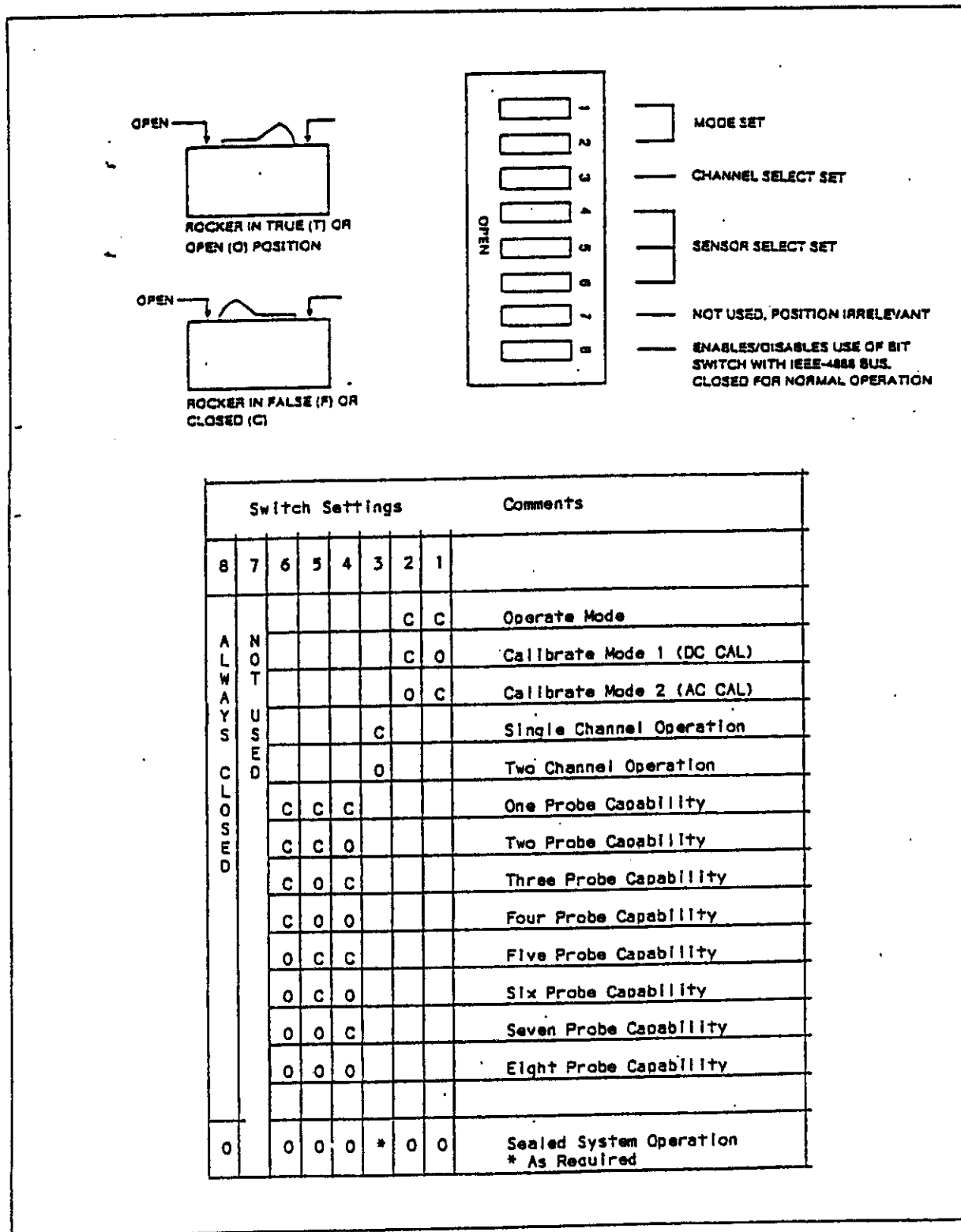

Figure 5-6. Control PC Board Bit Switch Settings.

SECTION V  
MAINTENANCE

5-44. (Continued).

- (1) Allow sufficient time for display to settle.
- (2) An indication between 4500 and 5500 is probably normal.

f. After each range adjustment above, the quality of the adjustment may be examined by setting the bit switch on the control board to OPERATE MODE and pressing the MODE mV and RANGE AUTO keys; the indication should agree with the Input (Model 26A setting) within several counts. If closer agreement is desired, either repeat the procedure for that range or manually adjust the gain factor for that range by pressing:

X,X,X,X, REF LEVEL dB

EXAMPLE: After the normal routine, the indication for the 100 mV range is 99.8 (0.2% low). Set the bit switch to CALIBRATE MODE 2 and recall the gain factor by pressing 4, MODE dBV, REF LEVEL dB.

A gain factor of 5040 is displayed. The desired change is +0.2%. Increase the gain factor by 0.2% ( $\approx 10$ ) to 5050 and enter by pressing:

5,0,5,0, REF LEVEL dB

Recheck in the OPERATE MODE.

g. Midscale Correction. In step c all the midscale corrections were set to 0 (no correction), and for the majority of probes this is quite satisfactory if it is found that a midscale correction is desirable it may be introduced as follows:

MODEL 26A	MODEL 9200B
1.5 mV	1, MODE dBV, X,X,X, MODE dBw
5 mV	2, MODE dBV, X,X,X, MODE dBw
15 mV	3, MODE dBV, X,X,X, MODE dBw
60 mV	4, MODE dBV, X,X,X, MODE dBw
300 mV	5, MODE dBV, X,X,X, MODE dBw
1500 mV	6, MODE dBV, X,X,X, MODE dBw

h. The midscale correction will also effect the full scale indication, but to a lesser degree. Full scale may be readjusted as was outlined in step e. This will, however, effect the midscale correction again. Moreover, there is not a one-to-one relationship between the counts entered for the midscale correction and the correction which results.

i. If one does not wish to readjust full scale, enter the number of counts that midscale is in error; this will result in under-correction for midscale but will disturb full scale the least.

j. If the greatest accuracy is desired and full scale will be readjusted, enter three times the counts by which midscale is in error.

EXAMPLE: The 3000 mV range having just been calibrated is reading 3000 mV. However, 1500

(midscale) is reading 1497; the error here is three counts. Correct as follows:

CORRECTION (AUTO)	AFTER CORRECTION		COMMENT
	MID	FULL	
0	1497	3000	No midscale correction
3	1498	3001	No full scale adjustment
9(3 x 3)	1501	3004	No full scale adjustment
9(3 x 3)	1499	3000	Full scale re-adjusted

k. Downscale Correction. To correct downscale indications, proceed as follows:

MODEL 26A	MODEL 9200B
0.21 mV	0, MODE dBV X,X,X, MODE X100
1.0 mV	1, MODE dBV X,X,X, MODE X100
2.4 mV	2, MODE dBV X,X,X, MODE X100
10 mV	3, MODE dBV X,X,X, MODE X100
30 mV	4, MODE dBV X,X,X, MODE X100
210 mV	5, MODE dBV X,X,X, MODE X100
1000 mV	6, MODE dBV X,X,X, MODE X100

l. Again, there is not a one-to-one relationship between the value entered and the correction which results. For these corrections, enter a value which is twice the desired correction. Downscale corrections have no effect on full scale indications. The reverse is not true however; therefore, full scale adjustment (and midscale corrections, if used) should be made prior to downscale corrections.

m. Calibration Check. Finally, check the results of calibration at the following levels:

SCALE	RANGE	INPUT
Full	6	3000 mV
Mid	6	1500 mV
Down	6	1000 mV
Full	5	700 mV
Mid	5	300 mV
Down	5	210 mV
Full	4	100 mV
Mid	4	60 mV
Down	4	30 mV
Full	3	24 mV
Mid	3	15 mV
Down	3	10 mV
Full	2	7 mV
Mid	2	5 mV
Down	2	2.4 mV
Full	1	2.1 mV
Mid	1	1.5 mV
Down	1	1.0 mV
Full	0	0.7 mV
Mid	0	0.5 mV
Down	0	0.21 mV

## 5-44. (Continued).

n. All indications should fall well within the uncertainties specified in the Performance Specifications of Section I, Table 1-3.

## NOTE

Because of range overlap it is possible in some instances to get an indication on two adjacent ranges for the same input level. Generally the indication near full scale (as opposed to downscale on the next higher range) will be the more accurate.

## 5-45. DC Recorder Calibration.

## 5-46. Perform the adjustment as follows:

- a. Set control board bit switch to OPERATE MODE. If the instrument is equipped with channel 2 (option 9200B-03), temporarily remove option to gain access to R55 on channel 1 (accessible through hole in channel 1 cover).
  - b. Connect DMM to recorder BNC connector on rear panel. Connect RF Probe to channel to be calibrated and to the 26A. Set 26A to ZERO. On 9200B, depress 1 channel (2 channel if 2nd channel is to be calibrated), N, PROBE, 0, REF LEVEL dB, dBw, mV, ZERO.
  - c. After ZERO cycle is completed, set 26A to 1000 mV. DMM should read 10 V for display of 100 mV  $\pm 0.1\%$ . If not, set control board bit switch to CALIBRATE MODE 1. Depress dBw. Display should read approximately 1170. Perform the following: [Display Indication  $\div$  (100  $\times$  DMM Indication)]  $\times$  the number located in dBw.
- EXAMPLE: Display reads 1000. DMM reads 9.96. dBw reads 1163. [1000  $\div$  (100  $\times$  9.96)]  $\times$  1163 = 1168.
- d. With control board bit switch in CALIBRATE MODE 1, depress the number calculated above (i.e., 1168) followed by dBw. Set control board bit switch to OPERATE MODE. Depress X100. Check DMM for accuracy indicated above. Set 26A for 300 mV. Adjust R55 for DMM to read 3 V for 300 mV display.

EXAMPLE: Display reads 0299. DMM reads 2.97. Adjust DMM to read 2.99. Full scale and down scale adjustment interact so re-check full scale and down scale until accuracy is obtained. Set control board bit switch to OPERATE MODE when complete.

## 5-47. TROUBLESHOOTING

5-48. Troubleshooting Concept. A technique called signature analysis has been devised to deal with microprocessor based systems. The troubleshooting procedures in this section are based on signature analysis techniques.

5-49. Signature Analysis. Long, complex data streams are present in microprocessor based, bus oriented systems. In signature analysis, with the system operating at normal

speed, these data streams are compressed into concise, easy-to-interpret readouts (signatures) measured at pertinent nodes. By choosing or generating appropriate measuring periods or windows, these signatures become unique; one and only one signature occurs at each node if operation is normal. Using signature analysis, it is possible to proceed through the instrument in an orderly fashion until a faulty signature is obtained. Generally, at that point, it is possible to identify one component as the most probable cause of the malfunction.

5-50. Signature analysis checks are of two basic types: "free running" and "stimulated" or programmed. In free-running checks, the data bus between the microprocessor and the system is opened and an instruction that will cause the microprocessor to free-run is forced. The microprocessor then runs through its address field repeatedly. Free-running checks may be used to check the following:

- a. Microprocessor address output.
- b. Memory select decoding.
- c. I/O select decoding.
- d. ROM program.

5-51. In the stimulated mode, the data bus between the microprocessor and the system bus is left intact and programs provided in a special ROM are invoked to conduct the desired tests. In this instrument, the stimulated mode is used to check the following:

- a. RAM operation.
- b. Display functions and scanning.
- c. Keyboard.
- d. I/O ports.

5-52. In this instrument, programmed signature analysis tests are activated by setting a bit switch, located at the rear of the control printed circuit board, to the number associated with the particular test. In using signature analysis, free-running tests should be performed first to ascertain that the microprocessor is putting out a normal address field, that the memory and I/O decoding is correct and that the ROM contents are normal. When correct signatures have been obtained for all free-running tests, the programmed tests may be performed.

5-53. The signature analysis technique is applicable only to the digital section of the instrument. Some sections of the instrument employ both analog and digital circuits. The input module, for example, receives a DC analog signal, amplifies the analog signal and converts it to a digital signal; the power supply uses both digital and analog circuitry to develop the voltages necessary for instrument operation. The discussion of these hybrid sections in Section III of this manual will be helpful in maintenance and servicing.

## SECTION V MAINTENANCE

### 5-54. Trouble Localization.

**5-55. Gaining Access to Internal Components.** To gain access to internal components of the instrument for maintenance or adjustment, remove the top and bottom covers by removing the securing screw at the rear of each cover and then sliding the cover to the rear. Figure 5-1 and 5-2 shows the location of major assemblies. To gain access to these assemblies, proceed as follows:

a. **Input Module.** To gain access to parts on the input module, remove four screws (one in each corner) and lift off the cover.

b. **Display Module.** To gain access to the display module, remove the top and bottom covers, then remove the four screws that attach the front top and bottom trim strips, and remove the top and bottom trim strips and the front panels.

**5-56. Visual Inspection.** With the instrument covers removed, inspect all assemblies for foreign material, unseated integrated circuits, transistors or connectors for broken leads, scorched components, loose screws and any other evidence of electrical or mechanical malfunction.

**5-57. Use of Block Diagrams.** By studying the detailed theory of operation in Section III together with the associated block diagrams, it may be possible to isolate the cause of an instrument malfunction to a particular block.

**5-58. Systematic Troubleshooting.** If visual inspection and block diagram analysis do not localize the source of an instrument malfunction, proceed with module troubleshooting as follows:

a. **Power Supply.** With normal input power applied to the instrument, check the power supply output voltages at each module power connector. Correct power supply voltages are shown on the applicable schematic diagrams. If an abnormal voltage is encountered, disconnect the module connector from the module and note whether the power supply output voltage becomes normal; if it does, the problem is probably not in the power supply but in the disconnected module. If, on the other hand, the abnormal voltage condition remains, work backward through the power supply circuits, comparing voltages with those shown on the power supply printed circuit board schematic diagram Figure 8-6. By analyzing abnormal indications, it should be possible to localize the problem to one or more components in the power supply.

b. **Input Module.** With a 700 mV signal applied to the probe, compare waveforms and voltages with those shown in Figure 5-7. Correct indications will essentially eliminate the input module as the source of an instrument malfunction; however, incorrect indications will not necessarily localize the problem to the input module because the input module depends on proper operation of the control module for such functions as ranging,

analog-to-digital conversion and recorder and meter output. If incorrect indications are obtained, localization of the problem using an oscilloscope and digital voltmeter may be a long and tedious process; a simpler approach may be to proceed with signature analysis.

c. **Display Module.** Proper operation of the display module is generally self-evident. Incorrect operation does not necessarily mean that the problem is in the display module; the control module may be malfunctioning. The simplest and quickest way to check the display module is by performing the visual and signature analysis checks specified in paragraph 5-58 and 5-61.

d. **Control Module.** If normal indications are obtained in checking the power supply, input and display modules of a malfunctioning instrument, the problem must be in the control module; however, it is very unlikely that this situation will occur because it is virtually impossible for the input and display modules to operate properly if the control module is malfunctioning. Signature analysis is the best way to localize a problem in the control module.

### 5-59. Signature Analysis Free-Running Test Procedures.

**5-60.** To make free-running signature analysis tests, proceed as follows:

#### CAUTION

Make certain that power is off before attempting to perform steps a, b and f of the following procedure. Failure to observe this caution may result in the loss or destruction of data stored in the non-volatile RAM.

#### NOTE

Prior to any signature analysis checks, note and record the settings of bit switch. Restore these switch settings upon completion of the signature analysis checks.

a. With power off, remove the data bus connector P1 on the control printed circuit board from socket J1 and disconnect jumper from connector J5. Do not remove any of the control printed circuit board PROMs.

b. Refer to Tables 5-2 through 5-6 for detailed information for the free-running tests. For each test, set the signature analyzer controls and make signature analyzer connections as specified in the applicable table.

#### NOTE

For instruments containing PROMs with codes differing from those referred to in the various signature analysis tables, contact the Boonton Service Dept. for correct signatures.

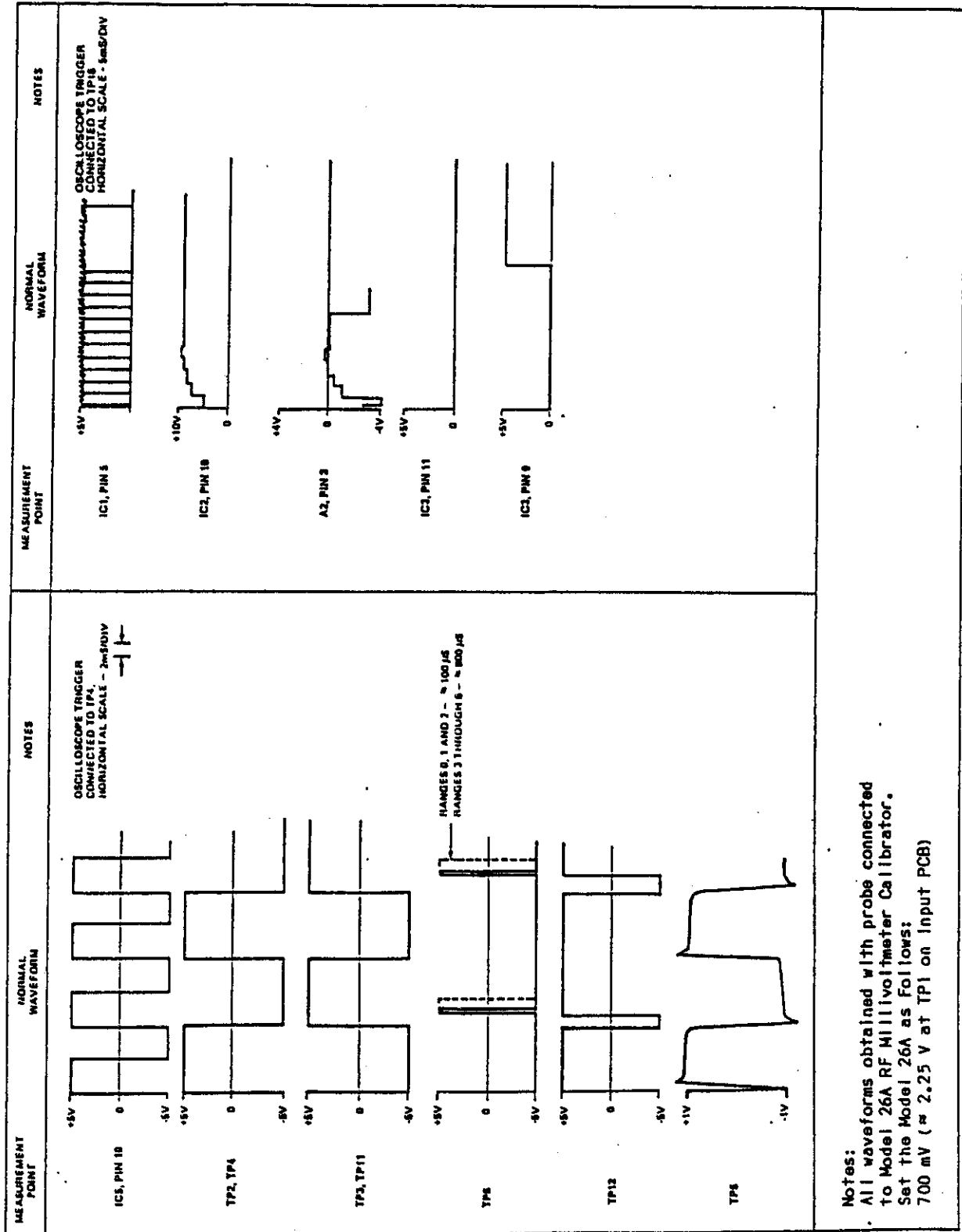





Figure 5-7. Input PC Board, Voltage and Waveform Data.

SECTION V  
MAINTENANCE



5-60. (Continued).

c. After setting and connecting the signature analyzer, apply power to the instrument. Touch the signature analyzer probe to the specified measurement points and compare the signatures obtained with those specified in the table. An incorrect signature is evidence of malfunction.

d. If an incorrect signature is noted, try replacing the integrated circuit(s) most intimately associated with the point at which the incorrect signature was obtained. For example, an incorrect signature in the address field would point to integrated circuit IC3 on the control printed circuit board, but the problem could be caused by any other integrated circuit or component tied to that address line.

TABLE 5-2. CONTROL BOARD ADDRESS FIELD TEST(1)											
Function	Signature Analyzer		Bit Switch(2)					Item	Measurement Point	Signature	
	Switch Setting	Connection Point	1	2	3	4	5				6
START		TP1									
STOP		TP1									
CLK		TP5									
			Any setting						Common +5V	0000	
									A0	IC3, pin 30	H335
									A1	IC3, pin 31	C113
									A2	IC3, pin 32	7090
									A3	IC3, pin 33	0772
									A4	IC3, pin 34	C4C3
									A5	IC3, pin 35	AA08
									A6	IC3, pin 36	7211
									A7	IC3, pin 37	A3C1
									A8	IC3, pin 38	7707
									A9	IC3, pin 39	577A
									A10	IC3, pin 40	HH86
									A11	IC3, pin 1	89F1
									A12	IC3, pin 2	AC99
									A13	IC3, pin 3	PCF3
									A14	IC3, pin 4	1180
									A15	IC3, pin 5	755U

(1) This test checks the output of the proper address field by CPU IC3; however, any item connected to an address line could be responsible for an incorrect signature on that line.  
(2) 0 = open.

TABLE 5-3. CONTROL BOARD MEMORY DECODING TEST(1)											
Function	Signature Analyzer		Bit Switch(2)					Item	Measurement Point	Signature	
	Switch Setting	Connection Point	1	2	3	4	5				6
START		TP1									
STOP		TP1									
CLK		TP5									
			Any setting						Common +5V	0000	
									<u>CS0</u>	IC4, pin 1	FU4U
									<u>CS1</u>	IC4, pin 2	A207
									<u>CS2</u>	IC4, pin 3	H6A3
									<u>CS3</u>	IC4, pin 4	HU34
									<u>CS4</u>	IC4, pin 5	H24U

(1) This test checks decoding for selection of memory integrated circuits.  
(2) 0 = open.

5-60. (Continued).

e. A signature of 0000 is obtained with the signature analyzer probe connected to common (ground). Some other items that will produce this signature are:

1. A node stuck at logic 0.
2. A node at the signature analyzer clock frequency.

f. A signature of 755U or 7A70 is obtained with the signature analyzer probe connected to +5 volts. Some other items that will produce the same signatures are:



1. A node stuck at logic 1.

2. Any signal with a specific relationship to the clock signal. If the clock signal is signal RD from the microprocessor, signals IORQ, WR and RFSH are examples of signals that will produce these signatures.



g. Upon completion of the free-running checks, turn power off. Then, reinstall data bus connector P1 in socket J1 on the control pcb and reinstall jumper at connector J5.

NOTE

If programmed signature analysis tests are to be performed, leave jumper disconnected from connector J5.

TABLE 5-4. CONTROL BOARD I/O DECODING TEST[1]														
Function	Signature Analyzer		Bit Switch[2]					Measurement Point	Signature					
	Switch Setting	Connection Point	1	2	3	4	5			6	7	8	Item	
START		TP1												
STOP		TP1												
CLK		TP5	Any setting					Common	0000					
								+5V	755U					
								<u>CS0</u>	IC14, pin 1	17UH				
								<u>CS1</u>	IC14, pin 2	7375				
								<u>CS2</u>	IC14, pin 3	253H				
								<u>CS3</u>	IC14, pin 4	8059				
								<u>CS4</u>	IC14, pin 5	PAOU				

[1] This test checks decoding for selection of I/O integrated circuits.  
[2] 0 = open

TABLE 5-5. CONTROL BOARD ROM 0 TEST[1]														
Function	Signature Analyzer		Bit Switch					Measurement Point	Signature					
	Switch Setting	Connection Point	1	2	3	4	5			6	7	8	Item	
START		TP7												
STOP		TP7												
CLK		TP5	Any setting					Common	0000					
								+5V	826P					
								D0	IC6, pin 9	P642				
								D1	IC6, pin 10	C111				
								D2	IC6, pin 11	5AC6				
								D3	IC6, pin 13	P470				
								D4	IC6, pin 14	4624				
								D5	IC6, pin 15	2P41				
								D6	IC6, pin 16	9456				
								D7	IC6, pin 17	UF62				

[1] This test checks the program content of ROM 0. (IC6)

SECTION V  
MAINTENANCE

TABLE 5-6. CONTROL BOARD ROM 1 TEST(1)											
Function	Signature Analyzer		Bit Switch					Item	Measurement Point	Signature	
	Switch Setting	Connection Point	1	2	3	4	5				6
START		TP19									
STOP		TP19									
CLK		TP5									
			Any setting						Common +5V	0000	
									D0	IC7, pin 9	P1AA
									D1	IC7, pin 10	P01P
									D2	IC7, pin 11	U865
									D3	IC7, pin 13	6A31
									D4	IC7, pin 14	A2CP
									D5	IC7, pin 15	HC35
									D6	IC7, pin 16	61U4
									D7	IC7, pin 17	H189

(1) This test checks the program content of ROM 1 (IC7).

TABLE 5-7. CONTROL BOARD 4A810 TEST(1)													
Function	Signature Analyzer		Bit Switch(2)					Item	Measurement Point	Signature			
	Switch Setting	Connection Point	1	2	3	4	5				6	7	8
START		TP6											
STOP		TP6											
CLK		TP5											
			C	C	C	C	C	C	C	C			
											Common +5V	0000	
										PB0	J3, pin 1	0000	
										PB1	J3, pin 2	0000	
										PB2	J3, pin 3	0000	
										PB3	J3, pin 4	0000	
										PB4	J3, pin 5	0000	
										PB5	J3, pin 6	0000	
										PB6	J3, pin 7	0000	
										PB7	J3, pin 8	0000	
			O	C	C	C	C	C	C	C	PB0	J3, pin 1	4F7C
			C	O	C	C	C	C	C	C	PB1	J3, pin 2	4F7C
			C	C	O	C	C	C	C	C	PB2	J3, pin 3	4F7C
			C	C	C	O	C	C	C	C	PB3	J3, pin 4	4F7C
			C	C	C	C	O	C	C	C	PB4	J3, pin 5	4F7C
			C	C	C	C	C	O	C	C	PB5	J3, pin 6	4F7C
			C	C	C	C	C	O	C	C	PB6	J3, pin 7	4F7C
			C	C	C	C	C	C	O	C	PB7	J3, pin 8	4F7C

(1) This test checks operation of ports A and B of the control module I/O port; the function of the bit switch is checked collaterally.

(2) O = open; C = closed

5-61. Signature Analysis Programmed Test Procedures.

NOTE

Perform the free-running signature analysis tests before proceeding with programmed tests. Signature analyzer connection points are on control board.

A Boonton Electronics diagnostic ROM kit, Part No. 96100301A is required for programmed signature analysis tests. This diagnostic ROM is included in Calibration Tape and Diagnostic ROM Kit part number 96200101A.

5-62. Use the following general procedure for each of the specified programmed signature analysis tests:

- a. Turn off power to the instrument.
- b. Remove ROMs IC6 and IC7 from their sockets on the control board, and remove the Interface board (if option 9200B-01B is installed). Refer to Figures 8-4 and A-2.
- c. Install a Boonton Electronics diagnostic ROM in the socket from which ROM IC6 was removed, being careful to observe proper pin 1 orientation.
- d. Check to see that connector P1 on the control board is connected to connector J1 and that connector P5 is connected to connector J5.
- e. Turn on input power to the instrument.
- f. Perform the test procedures specified in Tables 5-7 through 5-20. For each of the programmed signature analysis tests, make signature analyzer connections and switch settings as listed in the appropriate table. Then, set the bit switch on the control board as specified, connect the signature analyzer probe to the specified measurement points, and compare the signatures obtained on the signature analyzer with those listed in the table.
- g. Note that in each signature analysis test the signature analyzer probe is first checked on common (ground) and then on +5 volts. If the specified signatures are not obtained for these checks, do not proceed further; subsequent signatures cannot possibly be correct. Recheck all signature analyzer connections and switch settings.
- h. Both visual and signature analysis tests are provided for the display and keyboard of the instrument. Make the visual check first; it is fast and simple. If the visual check is satisfactory, the signature analysis test may be omitted.

i. If an incorrect signature is obtained at any point, replace the integrated circuit (or other active device) most intimately associated with the node at which the incorrect signature is obtained. If the signature is still incorrect after all active devices have been checked, all passive devices connected to that node should be suspect.

j. At the completion of all programmed signature analysis tests, turn off power to the instrument, remove the Boonton Electronics diagnostic ROM from the control board, and install ROMs IC6 and IC7 in their sockets on the control board and the interface board, ensuring that proper pin 1 orientation is observed.

k. Restore bit switch on the control board to the settings recorded at the start of signature analysis tests.

5-63. Non-Volatile RAM Circuit Test.

5-64. Test the Non-Volatile RAM as follows:

NOTE

Leave Boonton Electronics diagnostic ROM, part number 961003, installed on the control board as for the programmed signature analysis tests. Make sure that connector P5 on the control board is connected to connector J5.

- a. With power applied to the instrument, set all eight segments of the bit switch on the control board to the open position.
- b. Observe the instrument display. It should provide an error indication (cccc) initially.
- c. Turn input power off, then back on. If the non-volatile RAM is operating properly, the instrument display will show 1111.
- d. Repeat step c several times. The instrument display should always show 1111, not the error indication.
- e. Upon completion of this test, turn off input power to the instrument, remove the diagnostic ROM from the control board, and install integrated circuits IC6 and IC7 in their sockets on the control board and the interface board (if option 9200B-01B is installed), making certain that proper pin 1 orientation is observed.

SECTION V  
MAINTENANCE

TABLE 5-8. CONTROL BOARD 4C10 TEST(1)										
Function	Signature Analyzer		Bit Switch(2)					Item	Measurement Point	Signature
	Switch Setting	Connection Point	1	2	3	4	5			
START		TP6								
STOP		TP6								
CLK		TP5								
			0	C	C	C	C	C	C	0
								PC0	IC16, pin 14	5437
								PC1	IC16, pin 15	CCA9
								PC2	IC16, pin 16	1788
								PC3	IC16, pin 17	7C88
									Common +5V	0000 7C88



(1) This test checks the operation of part of port C of the control board I/O port.  
(2) 0 = open; C = closed

TABLE 5-9. CONTROL BOARD 4D10 TEST(1)										
Function	Signature Analyzer		Bit Switch(2)					Item	Measurement Point	Signature
	Switch Setting	Connection Point	1	2	3	4	5			
START		TP6								
STOP		TP6								
CLK		TP5								
			C	0	C	C	C	C	C	0
								PC4	IC16, pin 13	0000131
								PC4	IC16, pin 13	C35P141
									Common +5V	0000 58UA



(1) This test checks the operation of part of port C on the control board I/O port.  
(2) 0 = open; C = closed  
(3) Line voltage = 120 volts  
(4) Line voltage = 90 volts

TABLE 5-10. DISPLAY VISUAL TEST										
Bit Switch(1)		Instrument Display								
1	2 3 4 5 6 7 8									
0	0 C 0 0 C C 0	In succession: All zeros All ones through all nines All decimal points All left-most annunciators All left-most-1 annunciators All left-most-2 annunciators All right-most annunciators and - sign Repeat of above								

NOTE: If this visual check produces satisfactory results, there is no need to perform the associated signature analysis check.  
(1) 0 = open; C = closed

TABLE 5-11. CONTROL BOARD DISPLAY TEST(1) (ROM 950004)											
Function	Signature Analyzer		Bit Switch(2)					Item	Measurement Point	Signature	
	Switch Setting	Connection Point	1	2	3	4	5				6
START		TP6									
STOP		TP6									
CLK		TP5									
			0	0	C	0	0	C	C	0	
									D0	Common	0000
									D1	+5V	F72F
									D2	IC3, pin 14	94F8
									D3	IC3, pin 15	PH9U
									D4	IC3, pin 12	83FF
									D5	IC3, pin 8	4A1H
									D6	IC3, pin 7	H1P5
									D7	IC3, pin 9	F3A7
										IC3, pin 10	P85F
										IC3, pin 13	5536

(1) This test checks output of digital information to the display. The signature analysis gate in this test is quite lengthy (approximately 8 seconds); hold the signature analyzer probe on each test point for at least one complete window (approximately 20 seconds).  
 (2) 0 = open; C = closed

TABLE 5-12. CONTROL BOARD DISPLAY SCAN TEST(1)											
Function	Signature Analyzer		Bit Switch(2)					Item	Measurement Point	Signature	
	Switch Setting	Connection Point	1	2	3	4	5				6
START		TP4									
STOP		TP4									
CLK		TP8									
			0	0	C	0	0	C	C	0	
									S0	Common	0000
									S1	+5V	000U
									S2	IC18, pin 32	0000
									S3	IC18, pin 33	0005
										IC18, pin 34	0003
										IC18, pin 35	000U

(1) This test checks the control board display I/O chip for output of encoded scan data.  
 (2) 0 = open; C = closed



SECTION V  
MAINTENANCE

TABLE 5-13. KEYBOARD VISUAL TEST(1)		
Bit Switch(2) 1 2 3 4 5 6 7 8	Press Keyboard Key	Instrument Display
C C 0 C C C C 0	MODE mV	0
	MODE dB	1
	RANGE AUTO	2
	LIMITS dB LO	3
	SELECT Z <sub>0</sub>	4
	REF LEVEL dB	5
	MODE dBmV	8
	MODE dBV	9
	RANGE HOLD	10
	LIMITS dB HI	11
	SELECT CHNL	12
	CLR	13
	CHS	16
	5	17
	6	18
	7	19
	8	20
	9	21
	●	24
	0	25
	1	26
	2	27
	3	28
	4	29
	(SENS) PROBE	32
	ZERO	33



(1) This test is partly keyboard and partly control board because the I/O chip (IC18) for the display board resides on the control board.  
 (2) 0 = open; C = closed

TABLE 5-14. CONTROL BOARD RAM TEST(1)													
Function	Signature Analyzer Switch Setting	Connection Point	Bit Switch(2)					Measurement Point	Signature				
			1	2	3	4	5			6	7	8	
START		TP6											
STOP		TP6											
CLK		TP5						Common	0000				
								+5V	2915				
			0	C	C	C	C	C	C	0	PB0	J3, pin 1	5PPA
											PB1	J3, pin 2	77UU
											PB2	J3, pin 3	5PPA
											PB3	J3, pin 4	77UU
											PB4	J3, pin 5	5PPA
											PB5	J3, pin 6	77UU
											PB6	J3, pin 7	5PPA
											PB7	J3, pin 8	77UU

(1) This test writes bit patterns into each byte of the RAM, reads each byte and outputs it to the test socket at the rear of the control board where it is checked with the signature analyzer probe. While not completely exhaustive, this test will disclose most RAM failures.  
 (2) 0 = Open; C = Closed



TABLE 5-15. INPUT MODULE CHANNEL 1 OAI0 TEST(1)													
Function	Signature Switch Setting	Analyzer Connection Point(3)	Bit Switch(2)								Item	Measurement Point	Signature
			1	2	3	4	5	6	7	8			
START		TP6											
STOP		TP6											
CLK		TP5											
			C	O	O	C	C	C	C	O	PA0	IC1, pin 4	485P
											PA1	IC1, pin 3	1A33
											PA2	IC1, pin 2	F85P
											PA3	IC1, pin 1	5H7U
											PA4	IC1, pin 40	OFF1
											PA5	IC1, pin 39	F10C
											PA6	IC1, pin 38	9091
											PA7	IC1, pin 37	4P81
												Common	0000
												+5V	876P

(1) This test checks the operation of I/O port A of the input module; correct signatures depend on proper functioning of both the control board and the input module.  
 (2) O = open; C = closed  
 (3) Signature analyzer connection points are on the control board; measurement points are on input module board.



TABLE 5-16. INPUT MODULE CHANNEL 1 OBIO TEST(1)													
Function	Signature Switch Setting	Analyzer Connection Point(3)	Bit Switch(2)								Item	Measurement Point	Signature
			1	2	3	4	5	6	7	8			
START		TP6											
STOP		TP6											
CLK		TP5											
			O	O	O	C	C	C	C	O	PB0	IC1, pin 18	485P
											PB1	IC1, pin 19	1A33
											PB2	IC1, pin 20	F85P
											PB3	IC1, pin 21	5H7U
											PB4	IC1, pin 22	OFF1
											PB5	IC1, pin 23	F10C
											PB6	IC1, pin 24	9091
											PB7	IC1, pin 25	4P81

(1) This test checks the operation I/O port B of the input module; correct signatures depend on proper functioning of both the control board and the input module.  
 (2) O = open; C = closed  
 (3) Signature analyzer connection points are on the control board; measurement points are on input module board.



SECTION V  
MAINTENANCE

TABLE 5-17. INPUT MODULE CHANNEL 1 OCIO TEST(1)													
Function	Signature Analyzer Switch Setting	Connection Point(3)	Bit Switch(2)								Measurement Point	Signature	
			1	2	3	4	5	6	7	8			Item
START		TP6											
STOP		TP6											
CLK		TP5										Common	0000
											+5V		5064
											PC0	IC1, pin 14	6U01
											PC1	IC1, pin 15	671U
											PC2	IC1, pin 16	CFH2
											PC3	IC1, pin 17	121H



(1) This test checks the operation of part of I/O port C on the input module; correct signatures depend on proper operation of both the input module and the control board.  
 (2) 0 = open; C = closed  
 (3) Signature analyzer connection points are on the control board; measurement points are on input module board.

TABLE 5-18. INPUT MODULE CHANNEL 1 ODIO TEST(1)													
Function	Signature Analyzer Switch Setting	Connection Point(3)	Bit Switch(2)								Measurement Point	Signature	
			1	2	3	4	5	6	7	8			Item
START		TP6											
STOP		TP6											
CLK		TP5										Common	0000
											+5V		23HC(4)
													(or)
													5C43(4)
											P80	A5J3, pin 1	0000(4)
											P80	A5J3, pin 1	7H97(5)

(1) This test checks part of I/O port C of the input module for channel 1.  
 (2) 0 = open; C = closed  
 (3) Signature analyzer connection points and measurement points are on control board.  
 (4) Signature obtained with range calibrator connected to channel 1 input and range calibrator set to zero and  $R_s = 300k$ .  
 (5) Signature obtained with range calibrator connected to channel 1 input and range calibrator set to range 5 and  $R_s = 300k$ .

TABLE 5-19. INPUT MODULE CHANNEL 2 ICIO TEST(1)													
Function	Signature Analyzer		Bit Switch(2)								Measurement		
	Setting	Connection Point(3)	1	2	3	4	5	6	7	8	Item	Point	Signature
START		TP6											
STOP		TP6											
CLK		TP5											
			0	C	0	0	C	C	C	0	PC0	Common +5V	0000 5064
											PC1	IC1, pin 14	6U01
											PC2	IC1, pin 15	671U
											PC3	IC1, pin 16	CFH2
												IC1, pin 17	121H

(1) This test checks the operation of I/O port C of Input module 2. Correct signatures depend on proper operation of both the control board and Input module 2.  
 (2) 0 = open; C = closed  
 (3) Signature analyzer connection points are on the control board; measurement points are on input module board.

TABLE 5-20. INPUT MODULE CHANNEL 2 IOIO TEST(1)													
Function	Signature Analyzer		Bit Switch(2)								Measurement		
	Setting	Connection Point(3)	1	2	3	4	5	6	7	8	Item	Point	Signature
START		TP6											
STOP		TP6											
CLK		TP5											
			C	0	0	C	C	C	C	0	PB0	Common +5V	0000 P951(4) (or) 1088
											PB0	A5J3, pin 1	0000(4)
												A5J3, pin 1	7H97(5)

(1) This test checks part of I/O port C of the channel 2 input module.  
 (2) 0 = open; C = closed  
 (3) Signature analyzer connection points and measurement points are on control board.  
 (4) Signature obtained with range calibrator connected to channel 2 input, and range calibrator set to zero and  $R_s = 300k$ .  
 (5) Signature obtained with range calibrator connected to channel 2 input, and range calibrator set to range 5 and  $R_s = 300k$ .

SECTION VI  
PARTS LIST

## 6-1. INTRODUCTION

Table 6-2. Replaceable Parts, list all the replaceable parts and includes; the reference symbol, description, Mfr., Mfr's Part No.,

and the BEC Part No. Table 6-1. Manufacturer's Federal Supply Code Numbers, list the manufacturer's federal supply numbers.

TABLE 6-1. Manufacturer's Federal Supply Code Numbers

NUMBER	NAME	NUMBER	NAME
00853	Sangamo Electric	31918	ITT Schadow, Inc.
01121	Allen Bradley	32575	AMP
01295	Texas Instruments	33297	NEC
02114	Ferroxcube Corp.	33883	RMC
02735	RCA Solid State Div.	34335	Advanced Micro Devices
03888	Pyrofilm (KDI)	34649	Intel Corp.
03911	Clairex	50316	Mini Systems, Inc.
04222	AVX Ceramics Company	51406	Murata Corp. of America
04713	Motorola Semiconductor	51640	Analog Devices, Inc.
04901	Boonton Electronics	52464	OKI
06383	Panduit Corp.	52769	Sprague Goodman
06665	Precision Monolithics	53507	Robleyco
06776	Robinson Nugent, Inc.	54420	Dage - MTI
07263	Fairchild Semiconductor	54426	Buss Fuses
11961	Semicon	54473	Panasonic
13812	Dialco Div. of Ampere	55153	Dielectric Labs
14752	Electro Cube, Inc.	55285	Bergquist Co.
15542	Mini Circuits	56289	Sprague Electric Co.
17117	Electronic Molding	56708	Zilog, Inc.
18178	Vactec	59474	Jeffers Electronics, Inc.
18324	Signetics Corp.	61637	Kemet-Union Carbide
19505	Applied Eng'r. Products	71450	CTS Corp.
20307	Arco - Micronics	73138	Beckman Instr., Hellipot Div.
21604	Buckeye Stamping	78189	Shakeproof Div., Illinois Tool Co.
24226	Gowanda Electronics	78277	Sigma
25441	Power Group	79963	Zierick
26863	All States Plastics	81073	Grayhill
27014	National Semiconductor	90372	Wakefield
27264	Molex, Inc.	91168	Elmenco
27735	F-Dyne Electronics	95275	Vitramon Capacitors
27802	Vectron Labs	95721	Quality Components
28480	Hewlett-Packard Corp.	98291	Seallectro Corp.
31781	EDAC	54217	United Chemicon, Inc.
31827	Budwig		

SECTION VI  
PARTS LIST

TABLE 6-2. REPLACEABLE PARTS

09245200A		COMMON CHASSIS		9200B	
REFERENCE DESIGNATOR	DESCRIPTION	FED. CODE	MANUFACTURER PART NUMBER	QTY	BEC PART NUMBER
A2(2)	PWA DISPLAY	04901	04235801A	1	04235801A
A3(7)	(C) PWA CONTROL	04901	04223400E	1	04223400E
A7(5)	(C) PWA POWER SUPPLY	04901	04223100C	1	04223100C
A6(12)	(C) PWA INPUT	04901	04223001B	1	04223001B
W12	(C) CABLE ASSY PS TO DISPLAY	04901	57114200D	1	57114200D
W13	(C) CABLE ASSY PS TO CONTROL	04901	57114400C	1	57114400C
W14	(C) CABLE ASSY PS -CONTROL #2	04901	57114500C	1	57114500C
W16	(C) CABLE ASSY PS TO INPUT	04901	57114300C	1	57114300C
W21	(C) CABLE ASSY PS TO INTERFACE	04901	57114700C	1	57114700C

04235801A		PWA DISPLAY			
REFERENCE DESIGNATOR	DESCRIPTION	FED. CODE	MANUFACTURER PART NUMBER	QTY	BEC PART NUMBER
C3-4	CAP EL 10uF 20% 25V	34217	SM-25-VB-10-M	2	283336000
CR1-15	LED RED DIFF 5032-4684	28480	HLMP-1301	15	536024000
IC1	IC 74C48 BCD 7 SEG DECODER	27014	MM74C48N	1	534214000
IC2	IC 4051B 8 CHAN MULT/DEMULPL	02735	CD4051BE	1	534139000
IC3	IC 4049A HEX BUFF	02735	CD4049AE	1	534172000
IC4	PES NETWORK 100 OHM 2% 1.8W	01121	3168101	1	345021000
IC5	PES NETWORK 4.7K 2% 1.8W	01121	3168472	1	345020000
IC6	DISPLAY NUMERIC 5082-7653	28480	5082-7653	1	536809000
IC7	IC 8867 DRIVER	27014	DS8867N	1	534215000
IC8-11	DISPLAY NUMERIC 5082-7653	28480	5082-7653	4	536809000
J1	SOCKET IC 16 PIN	06776	ICH-163-S3-G	1	473042000
M1	NETEP MARKED	NOOTEC	00-700-093	1	554335000
P1	CONNECTOR 6 PIN STRAIGHT POLAR	27264	22-04-2061	1	477327000
P2	HEADUP 2 PIN RT ANGLE	06333	HFAS100-2-C	1	477367000
Q1	TRANS NPN 2N5039 BLUE	04713	2N5039	1	528047000
P4	PES MF 3.07K 1% 1/4W	19701	5043ED9Y090F	1	341392000
P5	PES MF 3.97K 1% 1/4W	19701	5043ED9A070F	1	341391000
P6	PES MF 15.0K 1% 1/4W	19701	5043ED13Y00F	1	341417000
P7	PES MF 4.75K 1% 1/4W	19701	5043ED4K750F	1	341365000
S1-26	SWITCH PUSHBUTTON SPST	31913	210272	26	465230000
XIC6	SOCKET IC 14 PIN	06776	ICH-143-S3-G	1	473019000
XIC8-11	SOCKET IC 14 PIN	06776	ICH-143-S3-G	4	473019000

04223400E		(C) PWA CONTROL			
REFERENCE DESIGNATOR	DESCRIPTION	FED. CODE	MANUFACTURER PART NUMBER	QTY	BEC PART NUMBER
BT1	CELL LITHIUM 3V	54473	BT-BR2725-1HB	1	556007000
C1	CAP HIGH 430pF 1% 500V	14655	CO13FD431F03	1	200037000
C2	CAP HIGH 100pF 5% 500V	14655	CH05FD101J03	1	200001000
C3	CAP TANT 15uF 10% 20V	56289	1960156Y9020YA1	1	283227000
C4-7	CAP EL 10uF 20% 25V	34217	SM-25-VB-10-M	4	283336000
CR1-2	DIODE SIG 1N914	01295	1N914	2	570052000
IC1	IC 7404 HEX INVERTER	01295	SN7404N	1	534042000
IC2	PES NETWORK 4.7K 2% 1.8W	01121	3168472	1	345020000
IC3	IC 280-CPU-PS	56708	280-CPU-PS	1	534159000
IC4	IC 74LS42 4-10 DECODER	01295	SN74LS42N	1	574210000
IC8	IC MSM5128-20-RS RAM 2K X 8	52464	MSM5128-20-PS	1	534304000
IC9	IC 4011 QUAD 2 INPUT NAND	02735	CD4011NE	1	534022000
IC13	PES NETWORK 4.7K 2% 1.8W	01121	3168472	1	345020000
IC14	IC 74LS42 4-10 DECODER	01295	SN74LS42N	1	574210000
IC15	IC 74LS32 QUAD 2 INPUT OR	01295	SN74LS32N	1	574168000

TABLE 6-2. REPLACEABLE PARTS

04223400E		(G) PWA CONTROL			
REFERENCE DESIGNATOR	DESCRIPTION	FED. CODE	MANUFACTURER PART NUMBER	QTY	REC PART NUMBER
IC16	IC 8255APC PERIPH INTERFACE	34335	AM8255APC	1	534171000
IC17	RES NETWORK 4.7K 2% 1.8W	01121	3166472	1	345620000
IC18	IC 8279-2 KEYBD/DISP INTERFACE	33297	UPD8279C-2	1	534211000
JB	CONNECTOR 2 PIN STRAIGHT	27264	22-03-2021	1	477361000
JA	CONNECTOR 2 PIN STRAIGHT	27264	22-03-2021	1	477361000
J1-2	SOCKET IC 16 PIN	06776	ICN-163-S3-G	2	473042000
J5	CONNECTOR 2 PIN STRAIGHT	27264	22-03-2021	1	477361000
L1	INDUCTOR 15uH 10%	24226	10M152K	1	400373000
P8	SHUNT 2 CIRCUIT	27264	15-38-1024	1	483253000
PA	SHUNT 2 CIRCUIT	27264	15-38-1024	1	483253000
P1	SHUNT 8 CIRCUIT	32575	435704-2	1	483226000
P2	(G) CONNECTOR 5 PIN RT ANG MOD	04901	47733300A	1	47733300A
P3	(G) CONNECTOR 5 PIN RT ANG MOD	04901	47733200B	1	47733200B
P4	(G) CONNECTOR 6 PIN RT ANG MOD	04901	47733100A	1	47733100A
P5	SHUNT 2 CIRCUIT	27264	15-38-1024	1	483253000
Q1	TRANS NPN 2N3904	04713	2N3904	1	528071000
R1	RES MF 332 OHM 1% 1/4W	19701	5043ED332R0F	1	341250000
R2-3	RES MF 10.0K 1% 1/4W	19701	5043ED10K00F	2	341400000
R4-5	RES MF 5.11K 1% 1/4W	19701	5043ED5K110F	2	341368000
R6	RES MF 100 OHM 1% 1/4W	19701	5043ED100R0F	1	341200000
R7	RES MF 10.0K 1% 1/4W	19701	5043ED10K00F	1	341400000
R8	RES MF 5.11K 1% 1/4W	19701	5043ED5K110F	1	341368000
R9-11	RES MF 4.75K 1% 1/4W	19701	5043ED4K750F	3	341365000
S1	SWITCH ROCKER 8PST DIP	01073	76S808	1	465225000
XIC3	SOCKET IC 40 PIN	06776	ICN-406-S4-TG	1	473052000
XIC6-8	SOCKET IC 24 PIN	06776	ICN-246-S4-G	3	473043000
XIC16	SOCKET IC 40 PIN	06776	ICN-406-S4-TG	1	473052000
XIC18	SOCKET IC 40 PIN	06776	ICN-406-S4-TG	1	473052000
XS1	SOCKET IC 16 PIN	06776	ICN-163-S3-G	1	473042000
04223100C		(G) PWA POWER SUPPLY			
REFERENCE DESIGNATOR	DESCRIPTION	FED. CODE	MANUFACTURER PART NUMBER	QTY	REC PART NUMBER
A13(2)	(G) HEAT SINK ASSEMBLY	04901	04223200B	1	04223200B
AR1	IC J39 QUAD COMPARATOR	27014	LM339N	1	535018000
C1-2	CAP EL 2200uF -10%+50% 35V	57582	KSMH-2200-35	2	283351000
C3	CAP EL 4700uF -10%+50% 16V	54217	SM-25-VB-100-M	1	283352000
C4	CAP EL 10uF 20% 25V	54217	SM-25-VB-10-M	1	283336000
C5-6	CAP EL 100uF 20% 25V	54217	SM-25-VB-100-M	2	283334000
C7	CAP EL 1000uF -10%+50% 10V	56289	513D108M0100G4	1	283329000
C8	CAP CER 3300pF 10% 100V	61637	C052K332K1X5CA	1	224296000
C9	CAP EL 100uF 20% 25V	54217	SM-25-VB-100-M	1	283334000
CR1	DIODE BRIDGE KBP-02	15281	KBP02	1	532013000
CR2	DIODE BRIDGE VS-248 6A 200 PIV	27777	VS-248	1	532014000
CR3-6	DIODE SIG 1N4001	04713	1N4001	4	530151000
IC1	IC 78L05 VOLT REG	07263	UA78L05AWC	1	535044000
IC6	IC 40138 DUAL FLIP FLOP	02735	CD4013BE	1	534205000
P1	HEADER 5 PIN STRAIGHT	06383	HP55156-5-D	1	477345000
P4-5	CONNECTOR 6 PIN STRAIGHT POLAR	27264	22-04-2061	2	477327000
P7-10	CONNECTOR 6 PIN STRAIGHT POLAR	27264	22-04-2061	4	477327000
R1	RES MF 10.0K 1% 1/4W	19701	5043ED10K00F	1	341400000
P2	RES MF 4.99K 1% 1/4W	19701	5043ED4K990F	1	341367000
R3	RES MF 2.21K 1% 1/4W	19701	5043ED2K210F	1	341333000
R4	RES MF 12.7K 1% 1/4W	19701	5043ED12K70F	1	341410000
R5	RES VAR 500 OHM 10% 0.5W	73138	72PR300	1	311305000
R6-8	RES MF 4.99K 1% 1/4W	19701	5043ED4K990F	3	341367000
R9	RES MF 1.00K 1% 1/4W	19701	5043ED1K000F	1	341300000
R10	RES MF 453 OHM 1% 1/4W	19701	5043ED453R0F	1	341263000
R11	RES VAR 100 OHM 10% 0.5W	73138	72PR100	1	311409000
R12	RES MF 464 OHM 1% 1/4W	19701	5043ED464R0F	1	341264000

SECTION VI  
PARTS LIST

TABLE 6-2. REPLACEABLE PARTS

04223100C

(G) PWA POWER SUPPLY

REFERENCE DESIGNATOR	DESCRIPTION	FED. CODE	MANUFACTURER PART NUMBER	QTY	BEC PART NUMBER
R13	RES MF 100K 1% 1/4W	19701	5043ED100K0F	1	341500000
R14	RES COMP 330 OHM 5% 1W	01121	GB3315	1	302087000
R15	RES MF 5.11K 1% 1/4W	19701	5043ED5K110F	1	341368000
R16	RES MF 2.21K 1% 1/4W	19701	5043ED2K210F	1	341333000
R17	RES MF 2.80K 1% 1/4W	19701	5043ED2R8000F	1	341343000
R18	RES MF 5.11K 1% 1/4W	19701	5043ED5K110F	1	341368000
R19	RES MF 51.1K 1% 1/4W	19701	5043ED51K10F	1	341468000

04223001B

(G) PWA INPUT

REFERENCE DESIGNATOR	DESCRIPTION	FED. CODE	MANUFACTURER PART NUMBER	QTY	BEC PART NUMBER
AR1	IC 301A OP AMP	27014	LM301AN	1	535012000
AR2	IC 311N OP AMP COMPARATOR	27014	LM311N	1	535034000
AR3	IC 301A OP AMP	27014	LM301AN	1	535012000
AR4	IC 3140 OP AMP	02735	CA3140AE	1	535050000
AR5-6	(G) IC 356B OP AMP SELECTED	04901	535062000	2	535062000
AR7	(G) IC SELECTED LF356 OPAMP	04901	535079000	1	535079000
AR8-9	IC 3140 OP AMP	02735	CA3140AE	2	535050000
C1	CAP CER 33pF 5% 1000V	56289	10TCC-Q33	1	224139000
C2	CAP EL 10uF 20% 25V	S4217	SM-25-VB-10-M	1	283336000
C3	CAP CER 33pF 5% 1000V	56289	10TCC-Q33	1	224139000
C4	CAP PE 0.01uF 10% 80V	56289	192P1039R8	1	234092000
C5	CAP CER 150pF 10% 600V	16546	CE-151	1	224314000
C6-7	CAP CER 33pF 5% 1000V	56289	10TCC-Q33	2	224139000
C8	CAP CER 1000pF 10% 600V	16546	CE-102	1	224310000
C9	CAP MICA 1500pF 1% 500V	14655	CD19FD152F	1	200531000
C12	CAP CER 0.01uF 100V	33883	BT 25U	1	224119000
C13	CAP CER 68pF 10% 600V	16546	DTZ-68	1	224312000
C14	CAP PE 0.01uF 10% 80V	56289	192P1039R8	1	234092000
C15	CAP CER 0.01uF 100V	33883	BT 25U	1	224119000
C16	CAP CER 68pF 10% 600V	16546	DTZ-68	1	224312000
C17	CAP CER 2200pF 10% 250V	16546	CF-222	1	224309000
C18	CAP PE 0.01uF 10% 80V	56289	192P1039R8	1	234092000
C19	CAP CER 330pF 10% 600V	16546	CE-331	1	224313000
C20	CAP PP 0.1uF 10% 100V	27735	PP11-.1-10-100	1	234148000
C22	CAP PP 0.1uF 10% 100V	27735	PP11-.1-10-100	1	234148000
C23	CAP CER 33pF 5% 1000V	56289	10TCC-Q33	1	224139000
C25	CAP CER 33pF 5% 1000V	56289	10TCC-Q33	1	224139000
C26	CAP CER 1000pF 10% 600V	16546	CE-102	1	224310000
C27-34	CAP EL 10uF 20% 25V	S4217	SM-25-VB-10-M	8	283336000
C35	CAP CER 150pF 10% 600V	16546	CE-151	1	224314000
C36	CAP EL 100uF 20% 25V	S4217	SM-25-VB-100-M	1	283334000
C37	CAP CER 1000pF 10% 600V	16546	CE-102	1	224310000
IC1	IC 8255APC PERIPH INTERFACE	34335	AM8255APC	1	534171000
IC2	IC 565 D/A CONVERTER 12 BIT	51640	AD565AJD	1	421034000
IC3	IC 4053B TRPL DECDR/DEMULTPXR	04713	MC14053BCP	1	534207000
IC5	IC 4047A MULTIVIB (RCA ONLY)	02735	CD4047AE	1	534229000
IC6	IC 4051B MULTIPLEXER RCA ONLY	02735	CD4051BE	1	534209000
IC7-8	IC 4013B DUAL FLIP FLOP	02735	CD4013BE	2	534205000
IC9-10	(G) IC 4016B QUAD SWITCH	02735	CD4016BE	2	534218000
IC11	IC 4075B TPPL 2 INPUT OR	02735	CD4075BE	1	534206000
IC13-14	IC 4051B MULTIPLEXER RCA ONLY	02735	CD4051BE	2	534209000
P2	(G) CONNECTOR 6 PIN RT ANG MOD	04901	47733100A	1	47733100A
R1	RES VAP 100 OHM 10% 0.5W	73139	72PR100	1	311408000
R2	RES MF 2.67K 1% 1/4W	19701	5043ED2K670F	1	341341000
R3	RES MF 1.00K 1% 1/4W	19701	5043ED1K000F	1	341300000
R4	RES MF 100 OHM 1% 1/4W	19701	5043ED100R0F	1	341200000
R5	RES MF 10.0K 1% 1/4W	19701	5043ED10K00F	1	341400000
R6	RES MF 5.11K 1% 1/4W	19701	5043ED5K110F	1	341368000
R7	RES MF 10.0K 1% 1/4W	19701	5043ED10K00F	1	341400000
R8	RES MF 9.25K 1% 1/4W	19701	5043ED9K250F	1	341368000
R9	RES MF 10.0K 1% 1/4W	19701	5043ED10K00F	1	341400000

TABLE 6-2. REPLACEABLE PARTS

04223001W		(G) PWA INPUT			
REFERENCE DESIGNATOR	DESCRIPTION	FED. CODE	MANUFACTURER PART NUMBER	QTY	BEC PART NUMBER
R10	RES COMP 3.0M 5% 1/4W	01121	C83055	1	343646000
R11	RES VAR 50K 10% 0.5W	73139	72PR50K	1	311393000
R12-13	RES MF 1.00M 1% 1/4W	14674	5043ED1M000F	2	341600000
R14	RES MF 237K 1% 1/4W	19701	5043ED237K0F	1	341336000
R15	RES MF 249K 1% 1/4W	19701	5043ED249K0F	1	341538000
R16	RES MF 12.1K 1% 1/4W	19701	5043ED12K10F	1	341408000
R17	RES MF 806K 1% 1/4W	19701	5043ED806K0F	1	341587000
R18-19	RES COMP 12M 5% 1/4W	01121	C81265	2	343708000
R20	RES MF 1.82K 1% 1/4W	19701	5043ED1K820F	1	341325000
R21	RES MF 20.0K 1% 1/4W	19701	5043ED20K00F	1	341429000
R22	RES MF 221K 1% 1/4W	19701	5043ED221K0F	1	341533000
R23	RES MF 1.00M 1% 1/4W	14674	5043ED1M000F	1	341600000
P25	RES MF 1.00M 1% 1/4W	14674	5043ED1M000F	1	341600000
R26-28	RES MF 100K 1% 1/4W	19701	5043ED100K0F	3	341500000
R30	RES MF 100K 1% 1/4W	19701	5043ED100K0F	1	341500000
R32	RES MF 9.09K 1% 1/4W	19701	5043ED9K090F	1	341392000
R34	RES MF 10.0K 1% 1/4W	19701	5043ED10K00F	1	341400000
P35	RES MF 5.11K 1% 1/4W	19701	5043ED5K110F	1	341368000
R36	RES VAR 10K 10% 0.5W	73139	72PR10K	1	311328000
P37	RES MF 3.92K 1% 1/4W	19701	5043ED3K920F	1	341357000
R38	RES MF 7.87K 1% 1/4W	19701	5043ED7K870F	1	341386000
R39	RES MF 80.6K 1% 1/4W	19701	5043ED80K60F	1	341487000
R40	RES MF 806K 1% 1/4W	19701	5043ED806K0F	1	341587000
R42	RES MF 7.50K 1% 1/4W	19701	5043ED7K500F	1	341384000
R44	RES VAR 200K 10% 0.5W	73139	72PR200K	1	311401000
R45	RES VAR 10K 10% 0.5W	73139	72PR10K	1	311328000
P47	RES MF 3.92K 1% 1/4W	19701	5043ED3K920F	1	341357000
R48	RES MF 909K 1% 1/4W	19701	5043ED909K0F	1	341592000
P49-52	RES MF 47.5K 1% 1/4W	19701	5043ED47K50F	4	341465000
P53	RES MF 100K 1% 1/4W	19701	5043ED100K0F	1	341500000
P54	RES MF 200K 1% 1/4W	19701	5043ED200K0F	1	341529000
R55	RES VAR 10K 10% 0.5W	73139	72PR10K	1	311328000
RT1	THERMISTOR 50 OHM 10%	00241	LB15J1-M	1	325007000
X14	SOCKET IC 6 PIN	06776	ICN-063-S3TG	1	473054000
XAR4-7	SOCKET IC 8 PIN	06776	ICN-083-S3-G	4	473041000
XIC1	SOCKET IC 40 PIN	06776	ICN-406-S4-TG	1	473052000
XIC2	SOCKET IC 24 PIN	06776	ICN-246-S4-G	1	473043000
XIC6	SOCKET IC 16 PIN	06776	ICN-163-S3-G	1	473042000
XIC9-10	SOCKET IC 14 PIN	06776	ICN-143-S3-G	2	473019000
092169008		RES NETWORK INPUT			
REFERENCE DESIGNATOR	DESCRIPTION	FED. CODE	MANUFACTURER PART NUMBER	QTY	BEC PART NUMBER
R29	RES MF 54.9K 1% 1/3W	19701	5063JD54K90F	1	338471000
R31	RES MF 54.9K 1% 1/3W	19701	5063JD54K90F	1	338471000
P33	RES MF 2.10K 1% 1/3W	19701	5063JD2K100F	1	338331000
34222502A		CHOPPER MODULE			
REFERENCE DESIGNATOR	DESCRIPTION	FED. CODE	MANUFACTURER PART NUMBER	QTY	BEC PART NUMBER
A4	PWA CHOPPER DUROID	04901	04216102A	1	04216102A

SECTION VI  
PARTS LIST

TABLE 6-2. REPLACEABLE PARTS

04216102A		PWA CHOPPER DUROID			
REFERENCE DESIGNATOR	DESCRIPTION	FED. CODE	MANUFACTURER PART NUMBER	QTY	BEC PART NUMBER
C1-2	CAP PP 0.1UF 10% 100V	27735	PP11-1-10-100	2	234148000
IC1	(G) IC SELECTED QUAD SWITCH	04901	534223000	1	534223000
P1	TERMINAL .040 OD .270 LG .062M	98291	229-1071-230	1	510038000
P2/1-2/2	CONNECTOR PIN	71279	460-1521-02-03-00	2	477400000
R3	RES MF 51.1K 1% 1/4W	19701	5043ED51K10F	1	341468000
P4-5	RES VAR 25K 10% 0.5W	73139	72PR25K	2	311400000
R6	RES MF 51.1K 1% 1/4W	19701	5043ED51K10F	1	341468000
NIC1	SOCKET IC 14 PIN	91506	714HGID	1	473056000
04235601A		(G) REAR PANEL UNIT			
REFERENCE DESIGNATOR	DESCRIPTION	FED. CODE	MANUFACTURER PART NUMBER	QTY	BEC PART NUMBER
P7	CONNECTOR LINE CORD	82389	EAC309	1	477281000
S2	SWITCH DUAL SLIDE DPDT-DPDT	82389	47206LFR	1	465279000
09245400A		REAR PANEL ASSY			
REFERENCE DESIGNATOR	DESCRIPTION	FED. CODE	MANUFACTURER PART NUMBER	QTY	BEC PART NUMBER
F1	FUSE 0.3 AMP 250V MDL	54426	MDL 0.3	1	545507000
J10	CONNECTOR 3 CIRCUIT	06383	CE156F24-3-C	1	479394000
J13	CONNECTOR PIN FEMALE	27264	0206-1231	1	479320000
J20	CONN COAX BNC	54420	UG-625/U	1	479123000
T1	TRANSFORMER POWER	04901	44609100A	1	44609100A
04223200B		(G) HEAT SINK ASSEMBLY			
REFERENCE DESIGNATOR	DESCRIPTION	FED. CODE	MANUFACTURER PART NUMBER	QTY	BEC PART NUMBER
IC2	IC 79MGUIC VOLT REG POS	07263	UA79MGUIC	1	535042000
IC3	(G) IC 79MGUIC MODIFIED	04901	53509700A	1	53509700A
IC4	IC 79GUIC VOLT REG	07263	UA79GUIC	1	535055000
IC5	(G) IC 79MGUIC MODIFIED	04901	53509700A	1	53509700A
46528900B		(G) SWITCH CABLE UNIT			
REFERENCE DESIGNATOR	DESCRIPTION	FED. CODE	MANUFACTURER PART NUMBER	QTY	BEC PART NUMBER
S1	SWITCH ROCKER DPDT	13812	572-2121-0103-010	1	465289000

TABLE 6-2. REPLACEABLE PARTS

57114200D		(G) CABLE ASSY PS TO DISPLAY			
REFERENCE DESIGNATOR	DESCRIPTION	FED. CODE	MANUFACTURER PART NUMBER	QTY	BEC PART NUMBER
J12	CONNECTOR SHELL 6 CIR	27264	22-01-2061	1	479376000
J17	CONNECTOR SHELL 6 CIR	27264	22-01-2061	1	479376000
57114400C		(G) CABLE ASSY PS TO CONTROL			
REFERENCE DESIGNATOR	DESCRIPTION	FED. CODE	MANUFACTURER PART NUMBER	QTY	BEC PART NUMBER
J13	CONNECTOR SHELL 6 CIR	27264	22-01-2061	1	479376000
J18	CONNECTOR 5 CIR	27264	22-01-2051	1	479377000
57114500C		(G) CABLE ASSY PS -CONTROL #2			
REFERENCE DESIGNATOR	DESCRIPTION	FED. CODE	MANUFACTURER PART NUMBER	QTY	BEC PART NUMBER
J14	CONNECTOR SHELL 6 CIR	27264	22-01-2061	1	479376000
J19	CONNECTOR SHELL 6 CIR	27264	22-01-2061	1	479376000
57114300C		(G) CABLE ASSY PS TO INPUT			
REFERENCE DESIGNATOR	DESCRIPTION	FED. CODE	MANUFACTURER PART NUMBER	QTY	BEC PART NUMBER
J16	CONNECTOR SHELL 6 CIR	27264	22-01-2061	1	479376000
J21	CONNECTOR SHELL 6 CIR	27264	22-01-2061	1	479376000
57114700C		(G) CABLE ASSY PS TO INTERFACE			
REFERENCE DESIGNATOR	DESCRIPTION	FED. CODE	MANUFACTURER PART NUMBER	QTY	BEC PART NUMBER
J23	CONNECTOR SHELL 6 CIR	27264	22-01-2061	1	479376000
J31	CONNECTOR 5 CIR	27264	22-01-2051	1	479377000
920052000		CABLE FLAT UNIT			
REFERENCE DESIGNATOR	DESCRIPTION	FED. CODE	MANUFACTURER PART NUMBER	QTY	BEC PART NUMBER
J24	CONNECTOR 40 PIN	04963	3464-0001	1	479379000
J26	CONNECTOR 40 PIN	04963	3464-0001	1	479379000
J28-29	CONNECTOR 40 PIN	04963	3464-0001	2	479379000

SECTION VI  
PARTS LIST

TABLE 6-2. REPLACEABLE PARTS

920046008		(G) CABLE UNIT 16 PIN			
REFERENCE DESIGNATOR	DESCRIPTION	FED. CODE	MANUFACTURER PART NUMBER	QTY	BEC PART NUMBER
P13-14	CONNECTOR 16 PIN DIP	04953	3416-0000	2	477289000

04216600A		(G) CABLE ASSY FLAT KIT			
REFERENCE DESIGNATOR	DESCRIPTION	FED. CODE	MANUFACTURER PART NUMBER	QTY	BEC PART NUMBER
W17	(G) CABLE UNIT 16 PIN	04901	920046008	1	920046008
W20	CABLE FLAT UNIT	04901	920052000	1	920052000

09171301A		PWA PROBE			
REFERENCE DESIGNATOR	DESCRIPTION	FED. CODE	MANUFACTURER PART NUMBER	QTY	BEC PART NUMBER
C2-3	CAP CER CHIP 1000pF 10% 50V	61637	C1210C102K5XAH	2	224286000
R1-2<SEL>	RES CHIP 63 OHM 5% 1/8W	01121	BCD68R0J	2	33990007A
R1-2<SEL>	RES CHIP 62 OHM 5% 1/8W	01121	BCD62R0J	2	33990006A
R1-2<SEL>	RES CHIP 75 OHM 5% 1/8W	01121	BCD75R0J	2	33990008A
R1-2<SEL>	RES CHIP 82 OHM 5% 1/8W	01121	BCD82R0J	2	33990009A
R1-2<SEL>	RES CHIP 91 OHM 5% 1/8W	01121	BCD91R0J	2	33990010A
R1-2<SEL>	RES CHIP 91 OHM 5% 1/8W	01121	BCD91R0J	2	33990005A
R1-2<SEL>	RES CHIP 56 OHM 5% 1/8W	01121	BCD56R0J	2	33990004A
R1-2<SEL>	RES CHIP 51 OHM 5% 1/8W	01121	BCD51R0J	2	33990001A
R1-2<SEL>	RES CHIP 10 OHM 5% 1/8W	01121	BCD10R0J	2	33990002A
R1-2<SEL>	RES CHIP 24 OHM 5% 1/8W	01121	BCD24R0J	2	33990003A
R1-2<SEL>	RES CHIP 33 OHM 5% 1/8W	01121	BCD33R0J	2	339900021A
P3-4	RES CHIP 1K 5% 1/8W	01121	BCD1001J	2	339900021A

09171201A		PROBE PWA/CONTACT ASSY			
REFERENCE DESIGNATOR	DESCRIPTION	FED. CODE	MANUFACTURER PART NUMBER	QTY	BEC PART NUMBER
C1	CAP CER 1400pF 20% 100V	55153	D018U142M1PX	1	224126000
CRI-2	DIODE SELECTED IT/F530022	04901	530181000	2	530181000

TABLE 6-2. REPLACEABLE PARTS

99201511A		92008-01B			
MODEL: 9200B-01B					
REFERENCE DESIGNATOR	DESCRIPTION	FED. CODE	MANUFACTURER PART NUMBER	QTY	BEC PART NUMBER
A23(A0)	PWA INTERFACE	04901	04223500A	1	04223500A
IC6(A5)	IC EPROM PROG 439AB 9200-01B	04901	53443900B	1	53443900B
IC7(A5)	IC EPROM PROG 440AB 9200-01B	04901	53444000B	1	53444000B
U8(A23)	IC EPROM PROG 441AB 9200-01B	04901	53444100B	1	53444100B
99201524A		92008-01B-06			
MODEL: 9200B-06					
REFERENCE DESIGNATOR	DESCRIPTION	FED. CODE	MANUFACTURER PART NUMBER	QTY	BEC PART NUMBER
A23(A0)	PWA INTERFACE	04901	04223500A	1	04223500A
IC6(A5)	IC EPROM PROG 430AB 9200B-06	04901	53443000B	1	53443000B
IC7(A5)	IC EPROM PROG 431AB 9200-06	04901	53443100B	1	53443100B
U8(A23)	IC EPROM PROG 432AB 9200-06	04901	53443200B	1	53443200B
U14(A23)	IC 82C54 TIMER	34371	CF92C54	1	53441000A

SECTION VII  
SCHEMATIC DIAGRAMS

7-1. TABLE OF CONTENTS

Figure		Page
7-1	Main Frame A1, Schematic Diagram . . . . .	7-3/7-4
7-2	Display Board A2, Schematic and Component Location Diagram . . . . .	7-5/7-6
7-3	Chopper Board A4, Schematic and Component Location Diagram . . . . .	7-7/7-8
7-4	Control Board A5, Schematic and Component Location Diagram, Sheet 1 of 2 . . . . .	7-9/7-10
7-5	Control Board A5, Schematic, Sheet 2 of 2 . . . . .	7-11/7-12
7-6	Input Module Board A6, Schematic and Component Location Diagram, Sheet 1 of 2 . . . . .	7-13/7-14
7-7	Input Module Board A6, Schematic, Sheet 2 of 2 . . . . .	7-15/7-16
7-8	Power Supply Board A7, Schematic and Component Location Diagram . . . . .	7-17/7-18
7-9	Options, Schematic Diagram . . . . .	7-19/7-20

A1 MAIN FRAME

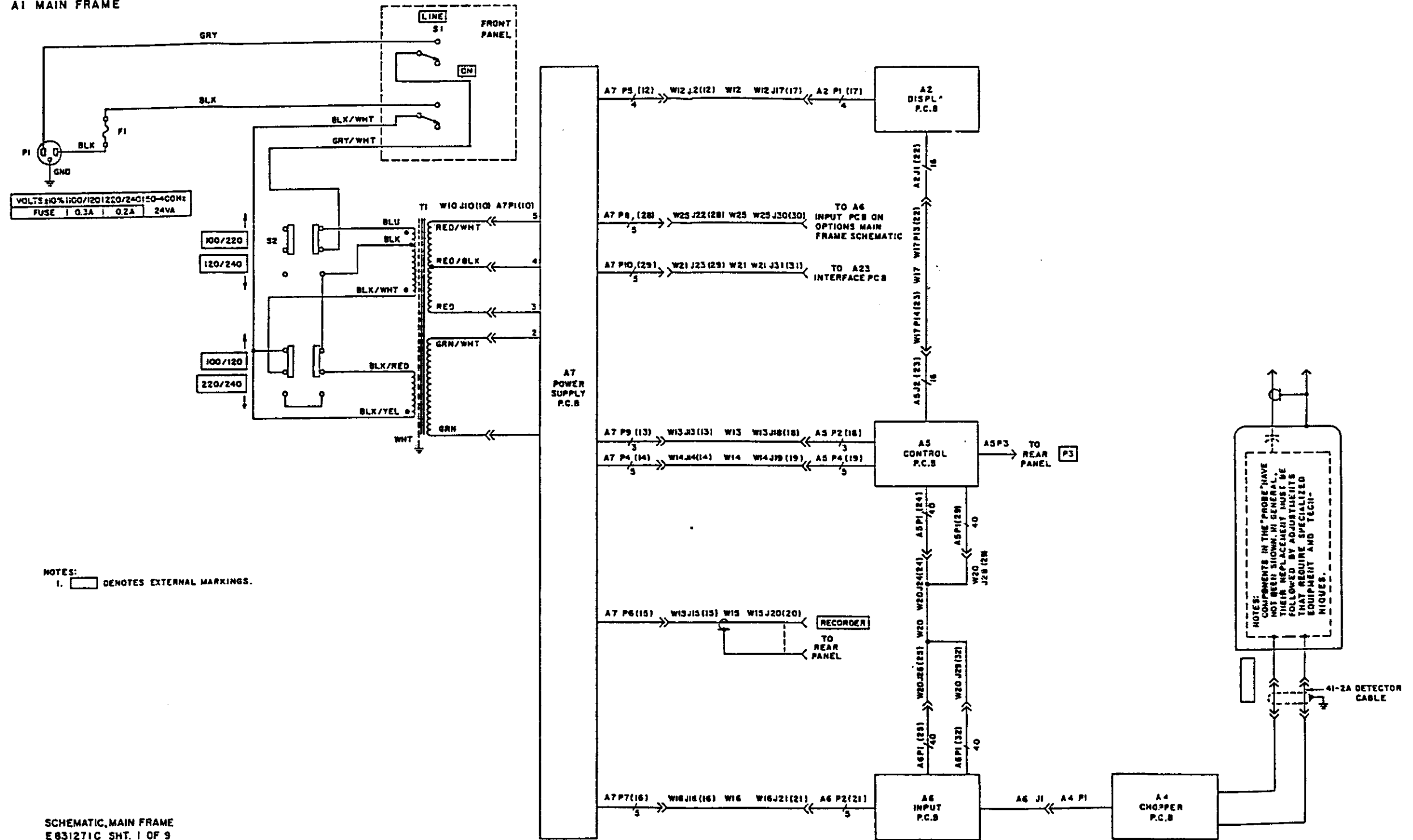

SCHEMATIC, MAIN FRAME  
E 831271C SHT. 1 OF 9

Figure 7-1. Main Frame A1,  
Schematic Diagram

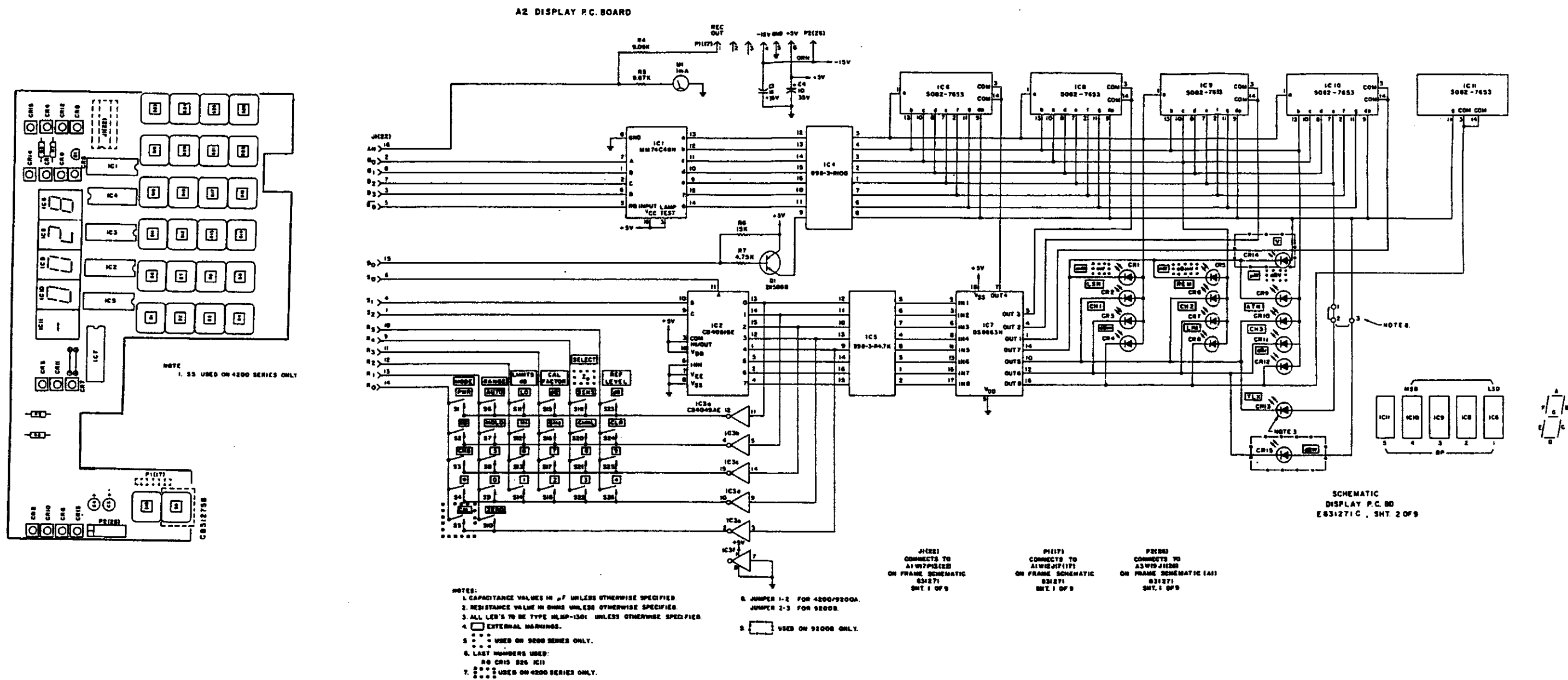
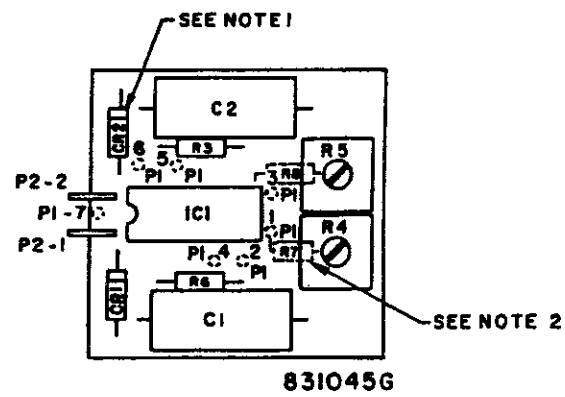
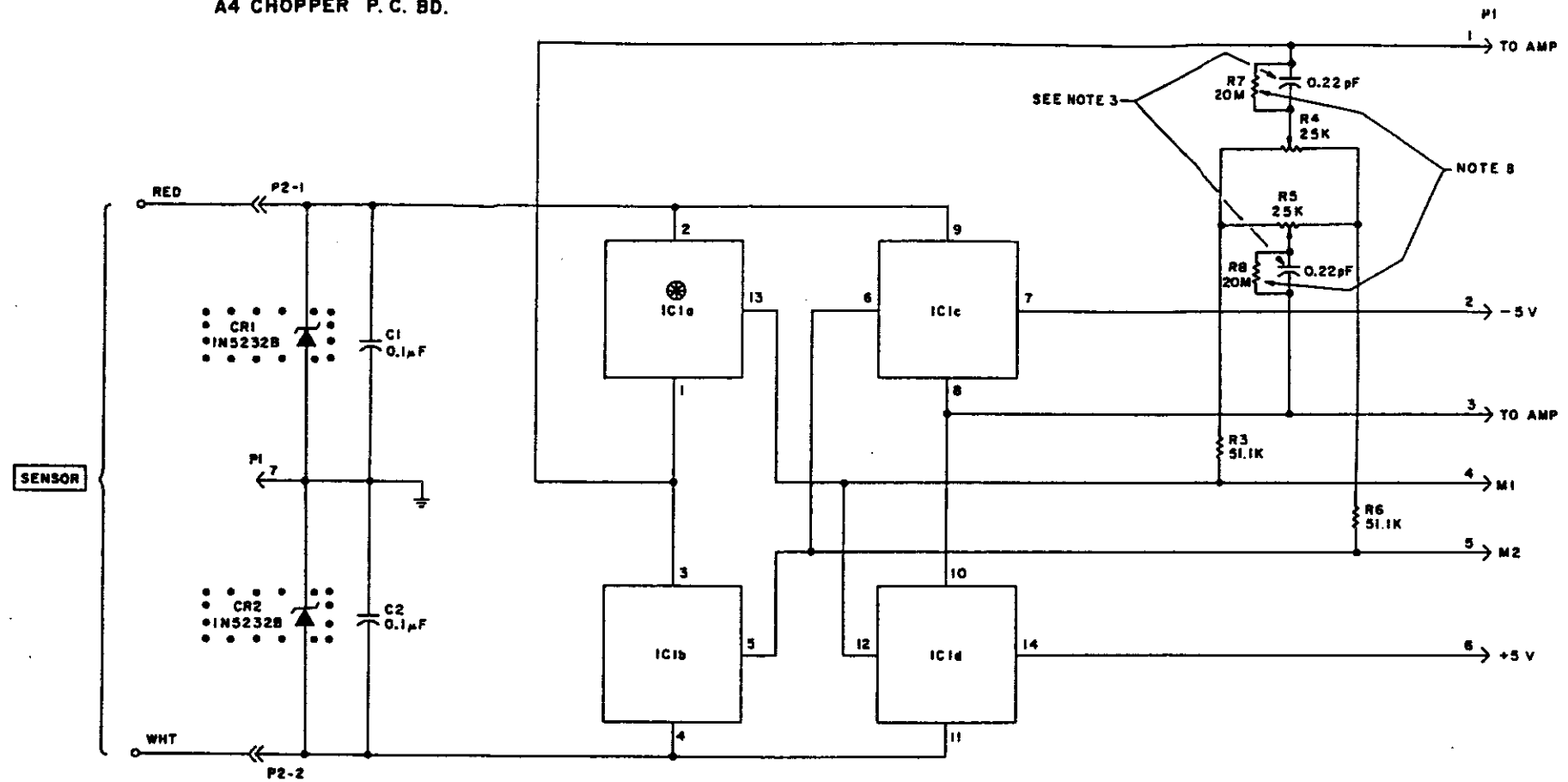

Figure 7-2. Display Board A2, Schematic and Component Location Diagram  
7-5/7-6

A4 CHOPPER P.C. BD.



NOTE  
1. CR1 AND CR2 USED ON 92E-S5 ONLY.  
2. R7 AND R8 USED WITH 4210-7E AND 4210-8E ONLY.



P1  
CONNECTS TO  
A6 J1  
ON FRAME SCHEMATIC  
831271  
SHT. 1 OF 7  
AND  
A6 J1  
ON OPTION FRAME  
SCHEMATIC  
831099  
AND  
A2 J2  
ON FRAME SCHEMATIC  
831170  
SHT. 1 OF 3

NOTES:

1. RESISTANCE VALUES IN OHMS.
2. ● SELECTED VALUE.
3. CAPACITANCE IS PART OF P.C. BD. CIRCUITRY.
4. □ EXTERNAL MARKING.
5. LAST NUMBERS USED:  
R 8
6. NUMBERS NOT USED:  
R1, R2
7. ● ● ● USED ON 92E-S5 ONLY.  
● ● ●
8. RES R7, R8 USED ONLY WITH 4210-7E  
AND 4210-8E SENSORS.

SCHEMATIC, CHOPPER P.C. BD.  
D831271 D SHT. 4 OF 9

Figure 7-3. Chopper Board A4, Schematic and Component Location Diagram

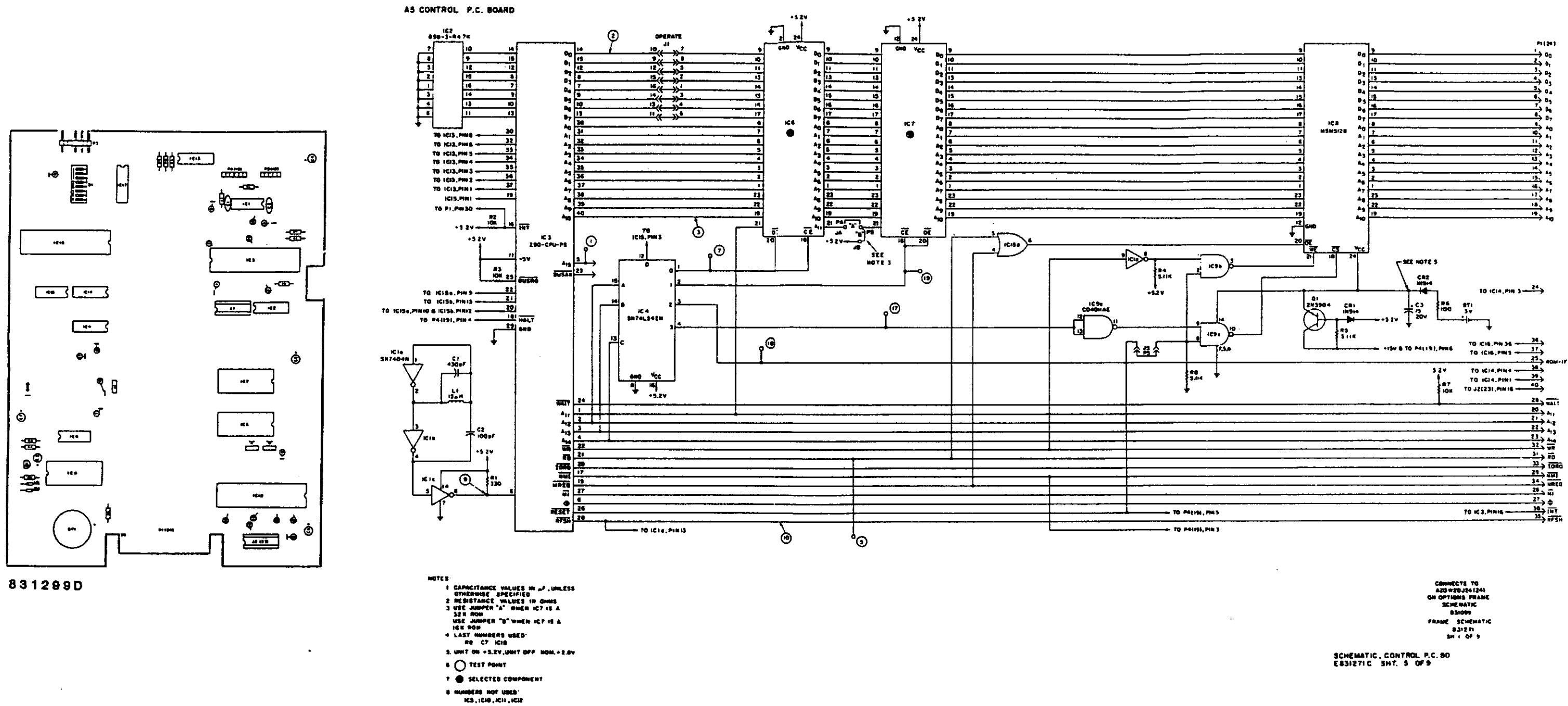

831298D

Figure 7-4. Control Board A5, Schematic and Component Location Diagram, Sheet 1 of 2

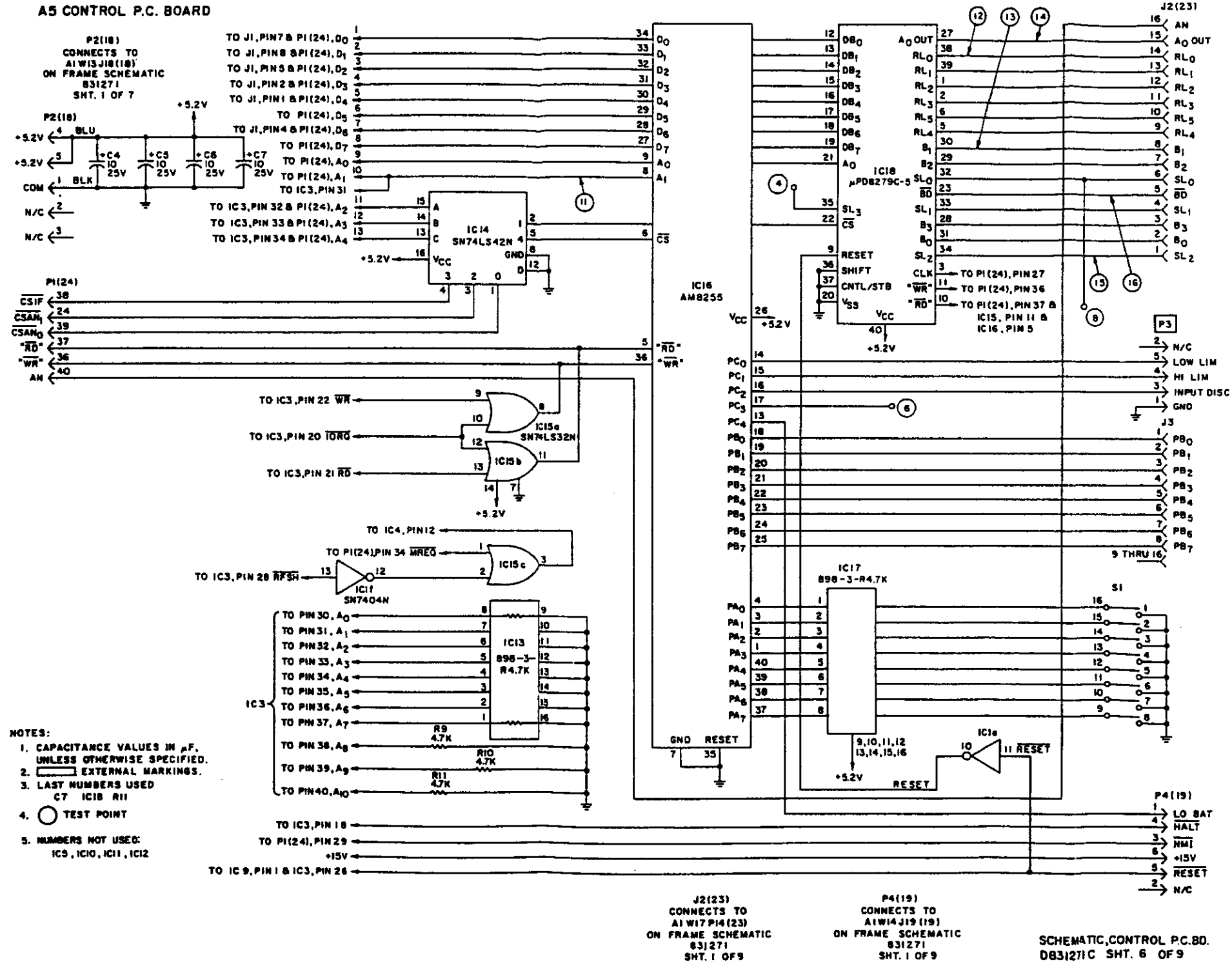

Figure 7-5. Control Board A5, Schematic, Sheet 2 of 2  
7-11/7-12

TEST POINT

13

14

15

16

WAVEFORM



ALL 2ms/DIV 4200  $\approx$  2.5mV INPUT  
9200  $\approx$  700mV INPUT TRIGGER AT TP 16

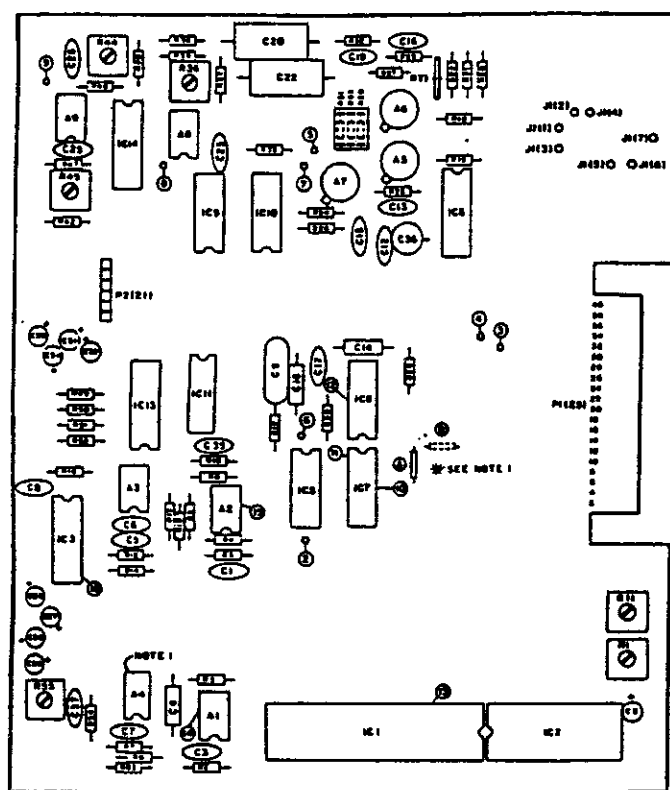

NOTES:  
1. CHANNEL 1 ADD JUMPER (B)  
CHANNEL 2 ADD JUMPER (A)  
REMOVE (B) & AS AMPLIFIER.

831276B

A6 INPUT MODULE P.C. BD.

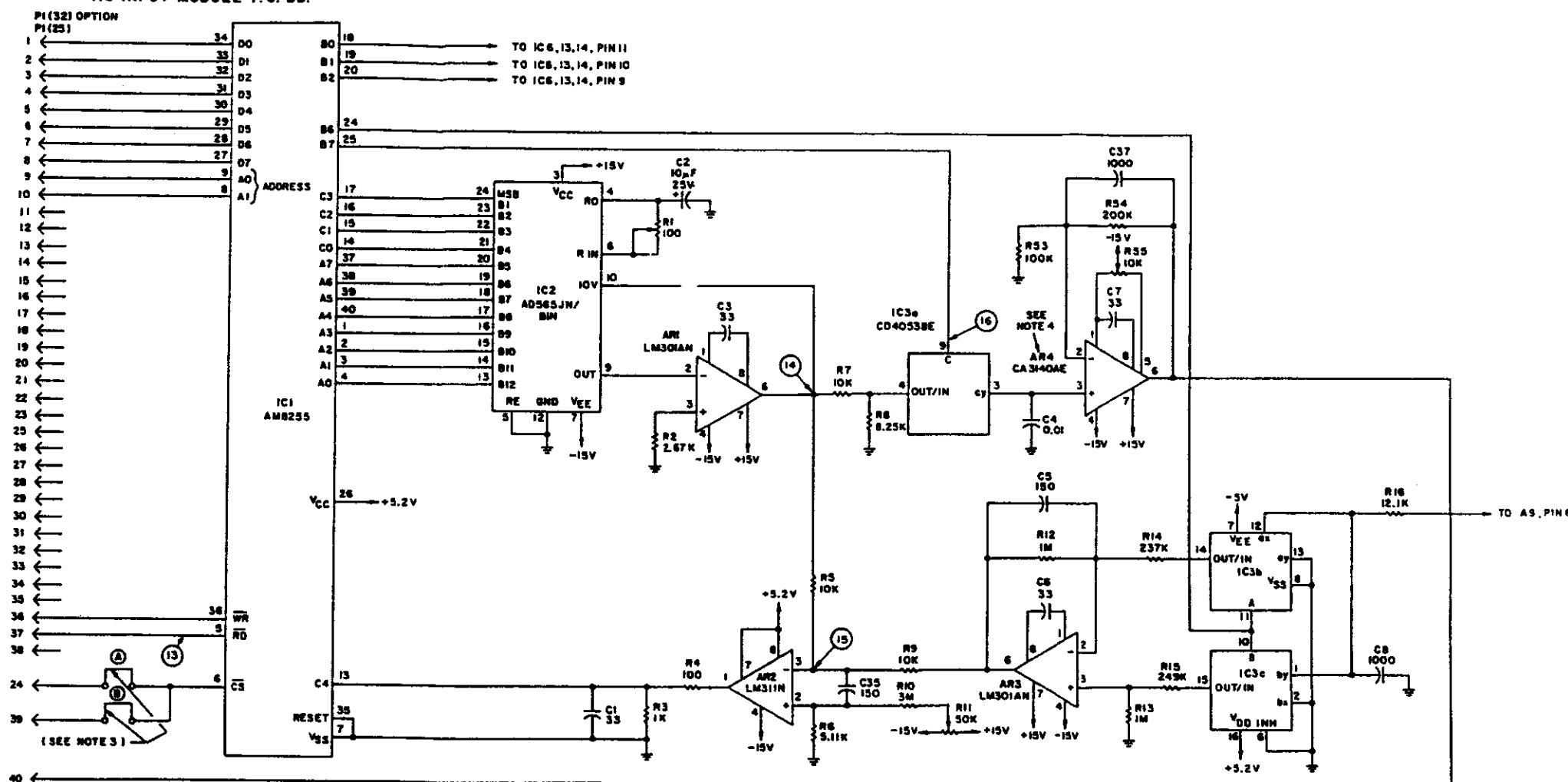

NOTES  
1. CAPACITANCE VALUES IN  $\mu$ F, UNLESS OTHERWISE SPECIFIED.  
2. RESISTANCE VALUES IN OHMS, UNLESS OTHERWISE SPECIFIED.  
3. CHANNEL 1 ADD JUMPER (B) ONLY. CHANNEL 2 ADD JUMPER (A) REMOVE (B)

4. AM NOT USED ON CHANNEL 2.  
5. (A) TEST POINT.

P1(25) CONNECTS TO A1WB J25(25) ON FRAME SCHEMATIC 831271 SMT. 1 OF 9

P1(32) CONNECTS TO A20W20J29(32) ON OPTION FRAME SCHEMATIC 831099

SCHEMATIC, INPUT MODULE P.C. BD. D831271A SHT. 7 OF 9

Figure 7-6. Input Module Board A6, Schematic and Component Location Diagram, Sheet 1 of 2

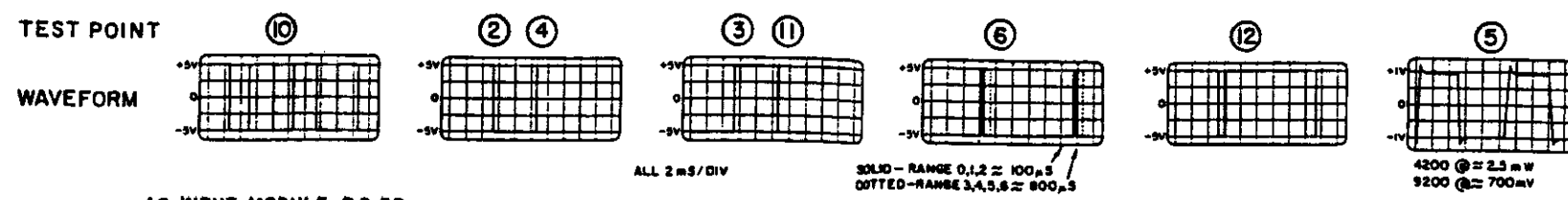

A6 INPUT MODULE P.C.B.D.

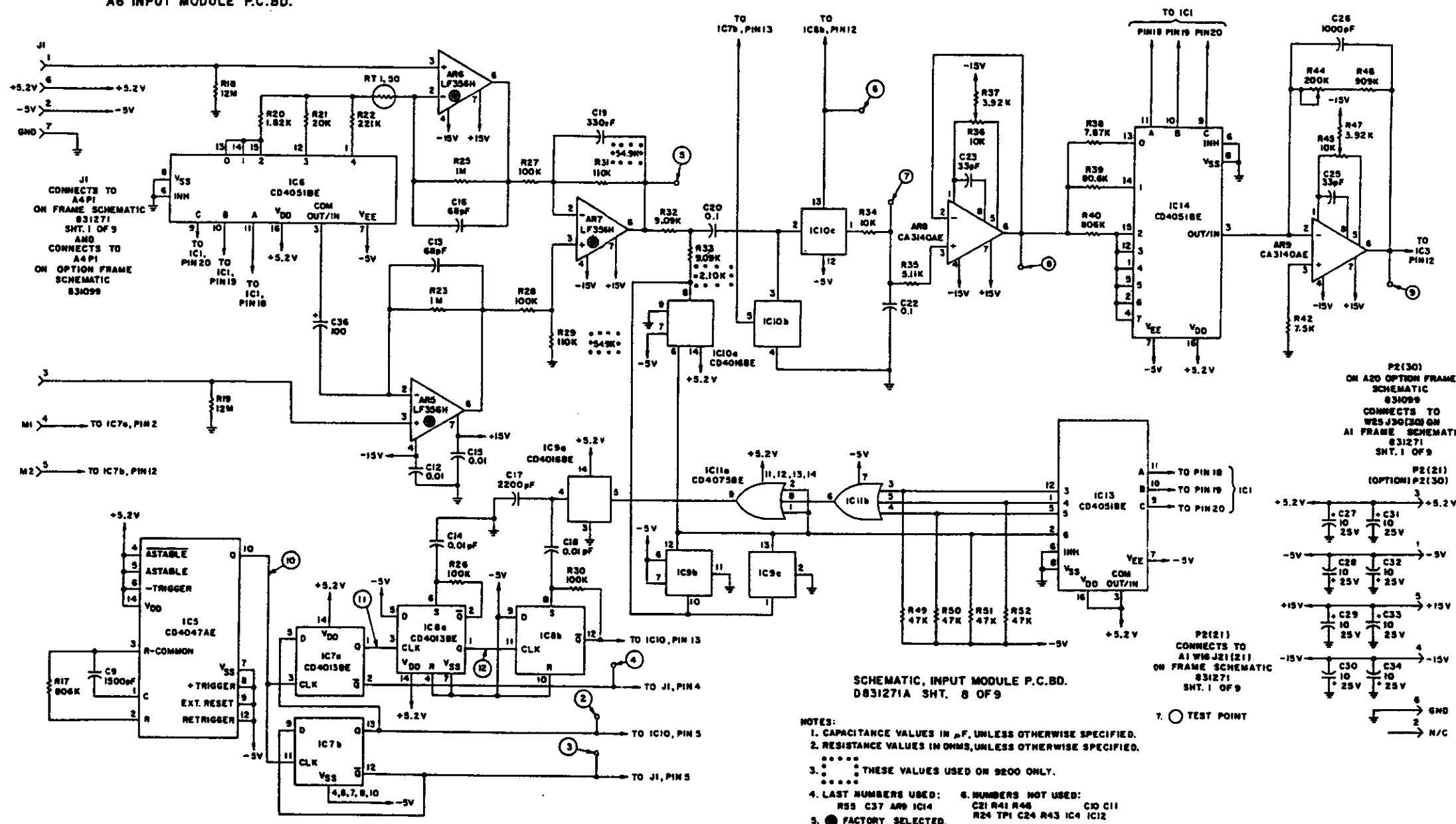
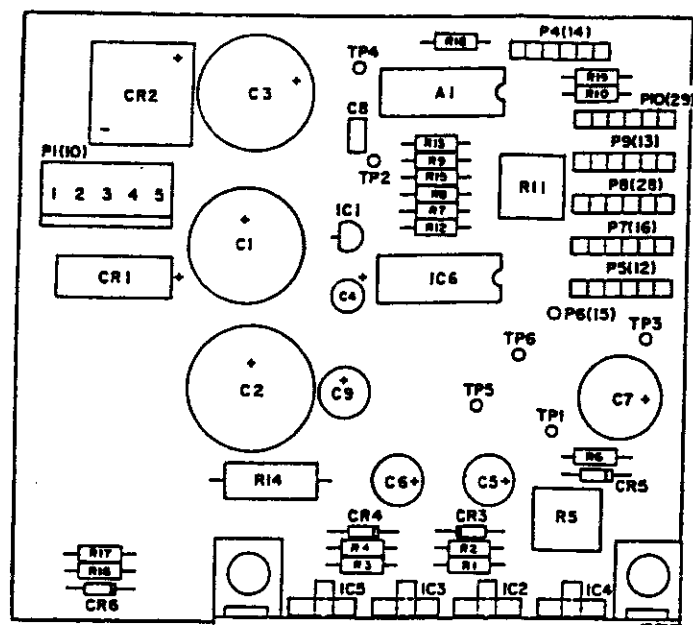

Figure 7-7. Input Module Board A6, Schematic, Sheet 2 of 2



831273B

P1 (10)  
CONNECTS TO  
A1 J10 (10)  
ON FRAME SCHEMATIC  
831271  
SHT. 1 OF 9

P5 (12)  
CONNECTS TO  
A1 W12 J12 (12)  
ON FRAME SCHEMATIC  
831271  
SHT. 1 OF 9

P4 (14)  
CONNECTS TO  
A1 W14 J14 (14)  
ON FRAME SCHEMATIC  
831271  
SHT. 1 OF 9

P6 (15)  
CONNECTS TO  
A1 W15 J15 (15)  
ON FRAME SCHEMATIC  
831271  
SHT. 1 OF 9

P7 (16)  
CONNECTS TO  
A1 W16 J16 (16)  
ON FRAME SCHEMATIC  
831271  
SHT. 1 OF 9

P9 (13)  
CONNECTS TO  
A1 W13 J13 (13)  
ON FRAME SCHEMATIC  
831271  
SHT. 1 OF 9

P8 (28)  
CONNECTS TO  
A1 W25 J22 (28)  
ON FRAME SCHEMATIC  
831271  
SHT. 1 OF 9

P10 (29)  
CONNECTS TO  
A1 W21 J23 (29)  
ON FRAME SCHEMATIC  
831271  
SHT. 1 OF 9

A7 POWER SUPPLY P.C. BD.

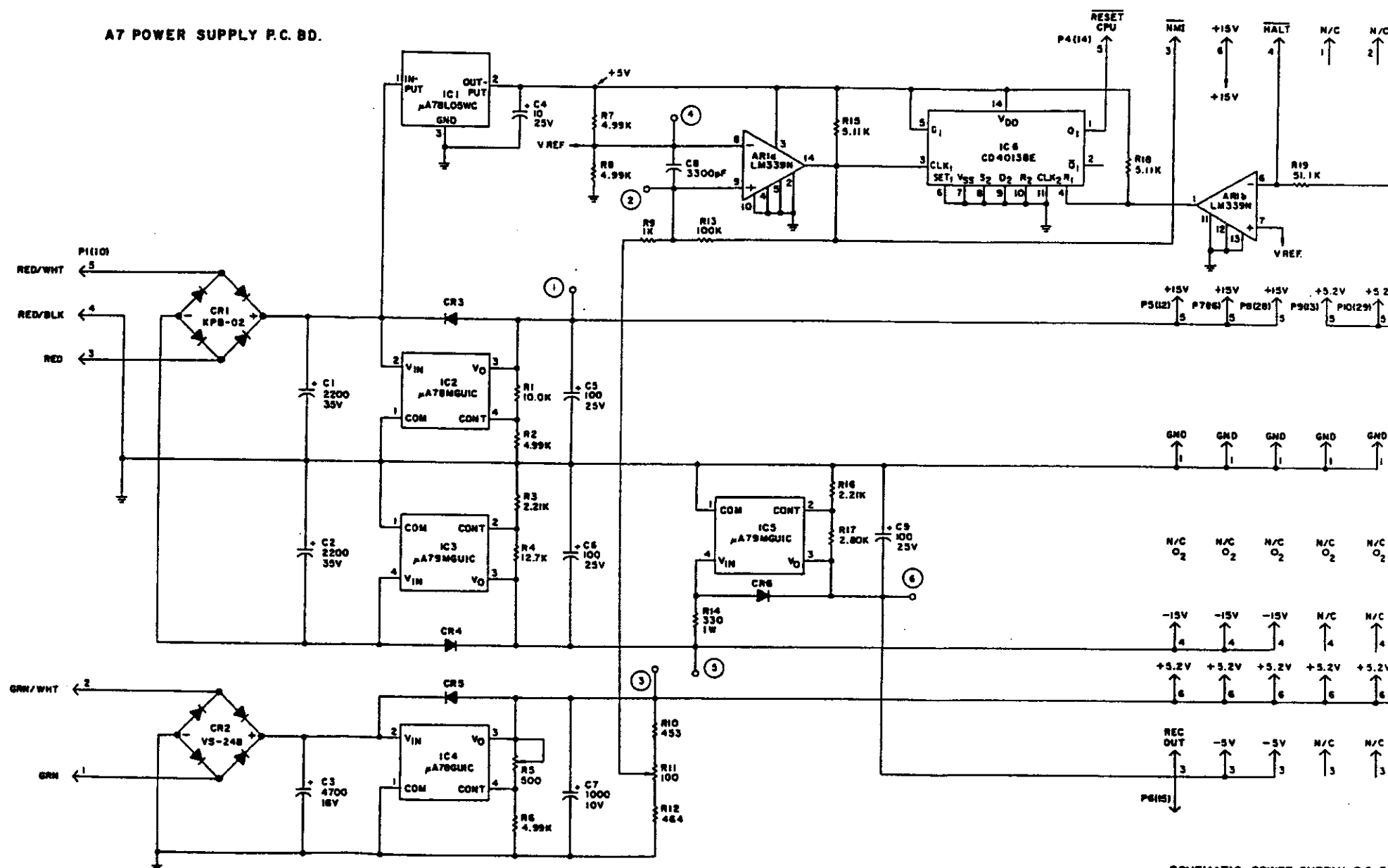

SCHEMATIC, POWER SUPPLY P.C. BD.  
E 831271 B SHT. 9 OF 9

- NOTES:
1. ALL CAPACITANCE VALUES IN  $\mu$ F, UNLESS OTHERWISE SPECIFIED.
  2. ALL RESISTANCE VALUES IN OHMS.
  3.  $\bigcirc$  TEST POINT
  4. LAST NUMBERS USED:  
R19 C9
  5. NUMBERS NOT USED:  
P2 P3

Figure 7-8. Power Supply Board A7, Schematic and Component Location Diagram

A20 MAIN FRAME

92008-01B

92008-03

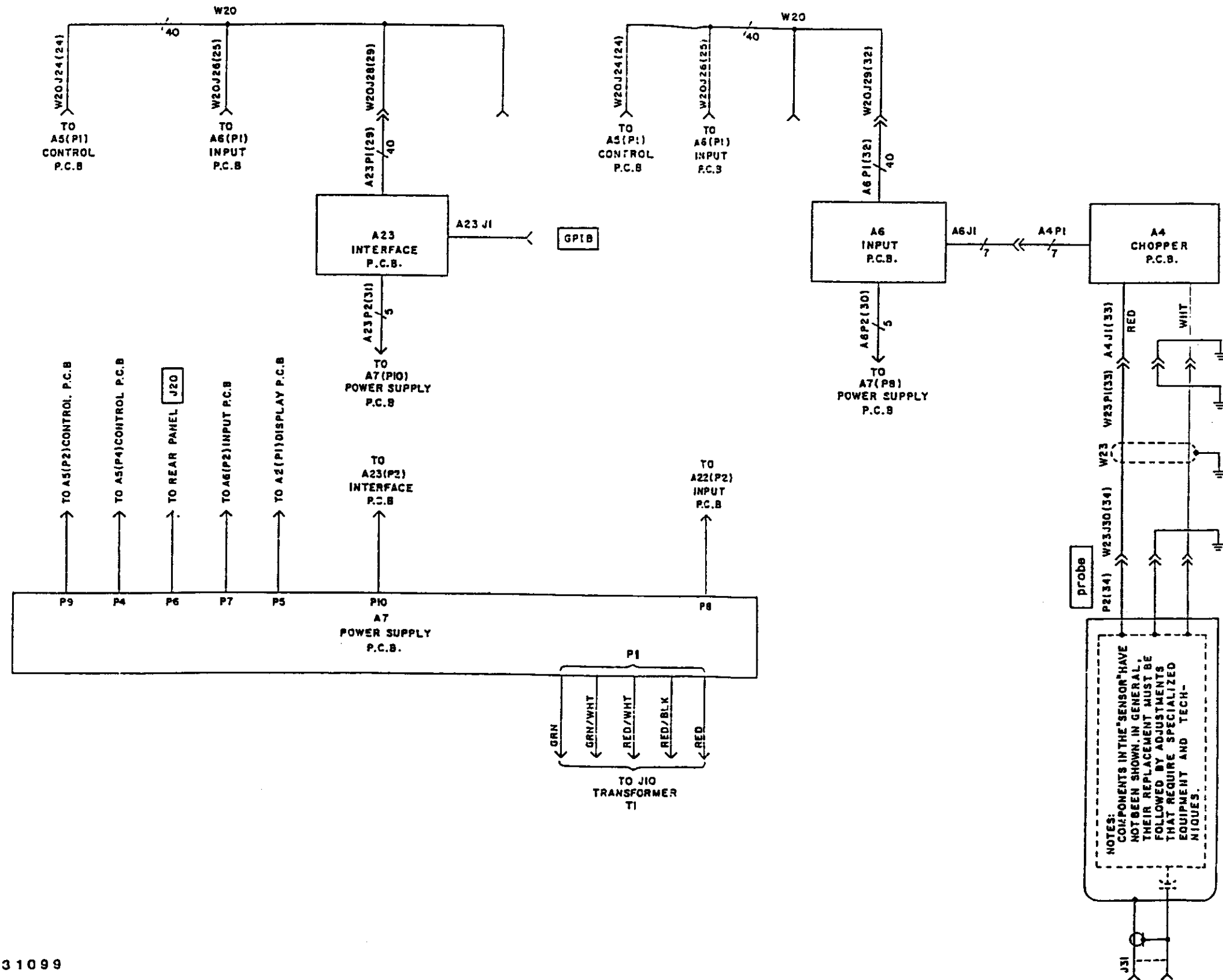

831099

Figure 7-9. Options, Schematic Diagram

APPENDIX A  
IEEE-488 BUS INTERFACE  
OPTION 9200B-01B

A-1. DESCRIPTION.

A-2. The IEEE-488 (GPIB) bus interface option permits external control of the instrument and data capture by a wide variety of compatible controllers. The instrument may be operated with other GPIB-compatible devices to achieve specific test automation goals, with no specialized control interface requirements for proper electrical operation.

A-3. Although no standard GPIB interface data formats have yet been established, certain common practices are achieving de-facto standard status. These practices have been adhered to in the design of the 9200B-01B option interface formats and delimiters, thereby assuring the user of format compatibility with almost all controllers.

A-4. CAPABILITY.

A-5. Certain subsets of full GPIB functions are specified in the IEEE-488 1978 Standard. The Model 9200B-01B option includes the following capabilities:

- SH1 SOURCE HANDSHAKE complete capability
- AH1 ACCEPTOR HANDSHAKE complete capability
- T6 BASIC TALKER, SERIAL POLL, UNADDRESS IF MLA, NO TALKER ONLY capability
- TE0 NO EXTENDED TALKER capability
- L4 BASIC LISTENER, UNADDRESS IF MTA, NO LISTENER ONLY capability
- LE0 NO EXTENDED LISTENER capability
- SR1 SERVICE REQUEST capability
- RL1 REMOTE-LOCAL capability, LOCAL LOCKOUT capability
- PP0 NO PARALLEL POLL capability
- DC0 NO DEVICE CLEAR capability
- DT1 DEVICE TRIGGER capability
- CO NO CONTROLLER capability

MLA = My Listen Address  
MTA = My Talk Address

A-6. INSTALLATION.

A-7. Option 9200B-01B consists of interface board A23. Electrical interconnections are shown in Figure 7-9. To install the interface board, proceed as follows:

- a. Turn off power to the instrument.
- b. Remove the screw that secures the top cover of the instrument and slide the top cover back and off.

c. Cut the cable tie in the instrument that holds the extra power plug (the plug with two blue wires and one black wire).

d. Remove the six screws that fasten the control board and replace them with the six mounting posts supplied with the -01B package.

e. Position the interface board in the instrument so that the mounting holes in the interface board line up with the mounting posts in the instrument. Attach the interface board to the mounting posts with six 4-40 screws and lockwashers supplied with the interface board.

f. Connect the 40 pin ribbon connector to the front edge connector of the interface board.

g. Connect the power plug in the instrument to the 4-pin brown connector on the interface board.

A-8. OPERATION.

A-9. Address Assignment. Before using the instrument in the GPIB, it must be assigned a unique address. This address is set using the five right-most sections of rear-panel address switch S1 in accordance with Table A-1.

A-10. Message Terminator. Positions 6 and 7 of the rear-panel switch S1 permit a choice of message terminators, as shown in Table A-2.

A-11. Command Response. In addition to Talk and Listen Address commands, the instrument responds to the following:

a. Address Commands (Response if Listen Addressed).

Mnemonic	Name	Function
GTL	Go To Local	Enables panel control
GET	Group Execute Trigger	Trigger a measurement

b. Listen Address Group.

Mnemonic	Name	Function
UNL	Unlisten	De-address as listener

c. Talk Address Group.

Mnemonic	Name	Function
UNT	Untalk	De-address as talker

*Decimal Address	Talk Code	Listen Code	Switch Setting				
			5	4	3	2	1
0	@	SP	0	0	0	0	0
1	A	!	0	0	0	0	1
2	B	"	0	0	0	1	0
3	C	#	0	0	0	1	1
4	D	\$	0	0	1	0	0
5	E	%	0	0	1	0	1
6	F	&	0	0	1	1	0
7	G	'	0	0	1	1	1
8	H	(	0	1	0	0	0
9	I	)	0	1	0	0	1
10	J	*	0	1	0	1	0
11	K	+	0	1	0	1	1
12	L	,	0	1	1	0	0
13	M	-	0	1	1	0	1
14	M	.	0	1	1	1	0
15	N	/	0	1	1	1	1
16	O	0	1	0	0	0	0
17	P	1	1	0	0	0	1
18	Q	2	1	0	0	1	0
19	R	3	1	0	0	1	1
20	S	4	1	0	1	0	0
21	T	5	1	0	1	0	1
22	U	6	1	0	1	1	0
23	V	7	1	0	1	1	1
24	X	8	1	1	0	0	0
25	Y	9	1	1	0	0	1
27	[	;	1	1	0	1	1
28	\	<	1	1	1	0	0
29		=	1	1	1	0	1
30	^	>	1	1	1	1	0

\*Address 31 (11111) will not be recognized and should not be used.

SWITCH		MESSAGE TERMINATOR
7	6	
Off	Off	EOI
Off	On	CR*
On	Off	LF*
On	On	CR LF*

\*With or without EOI

A-11. (Continued).

d. Unencoded Commands.

Mnemonic	Name	Function
IFC	Interface Clear	Initialize interface
REN	Remote Enable	Permits remote operation

A-12. Operating States. The instrument operates in two separate states, whether in local or remote control. One state is the measurement state, during which the instrument performs and displays measurements; the other state is the data entry/recall state, which is operative during number entry or after recall of stored information. When operating on the bus, it is important to remember that the instrument can send only that information which appears on the front panel display. When the instrument is in the store or recall mode, the LED display and annunciators blink on and off to indicate that the displayed value is not a measured value.

a. Measurement Mode Functions. The following functions change the measurement mode of the instrument:

Keyname	GPIB	Function
MODE mV	P	Displays measured voltage
MODE dBmV	B	Displays measured dBmV
MODE dBV	V	Displays measured dBV
MODE dBW	W	Displays measured dBW

Command	Arm	Disarm	Description
Q	1Q	0Q	Hold command: the last reading, or the last keyboard entry, will remain on the display. The instrument will continue to read probe input, but will not update the display. The instrument cycle time will be greatly reduced because of the measurement-cycle overhead that is not executed during the hold command.
S	1S	0S	Service request command: the service request will be issued by the instrument upon completion of a measurement.
	2S		SRQ on settled reading
J	1J	0J	Raw-data command: the instrument will not average or smooth any of the measurements.
U	1U	0U	Limit command: the instrument will issue a service request if any limit is exceeded. If a limit is exceeded and a service request is issued, the U command must be rearmed to become operational again.
T			Trigger command: this command, identical with the IEEE-488 group execute trigger, initiates a measurement cycle.

INTERFACE CLEAR and DEVICE disarm all the above commands.

A-12. (Continued).

b. Command Functions. Table A-3 describes command functions.

Keyname	GPiB	Function
MODE dBm	D	Displays measured dB
RANGE AUTO	A	Sets autorange mode
RANGE HOLD	0	Sets range hold mode
X100	OK	Sets X1 mode
	1K	Sets X100 mode
SEL AVERAGE	0F	Sets auto average
	nF	Sets select average (n = 1-127)

c. Service Request Status Codes. Service request status is defined by a five-bit code, as defined in Table A-4.

BIT					Meaning
4	3	2	1	0	
X	X	X	0	1	Ch 1 low limit exceeding
X	X	X	1	0	Ch 1 high limit exceeding
X	0	1	X	X	Ch 2 low limit exceeding
X	1	0	X	X	Ch 2 high limit exceeding

d. Data Entry/Recall Functions. These functions enable entry or retrieval of numeric constants used by the instrument. Operation reverts to the measuring state after data storage.

Keyname	GPiB	Function
LIMITS dB LO	L	Low limit value in dB
LIMITS dB HI	H	High limit value in dB
SELECT CHNL	N	Selects channel number
dB REF LEVEL dB	R	dB reference level for dB modes
SELECT Z <sub>0</sub>	I	Impedance reference for 1 mW
SELECT PROBE	X	Selects probe number

e. Special Functions. Special functions include the automatic zeroing and clear functions.

Keyname	GPiB	Function
ZERO	Z	Initiate an automatic zeroing cycle
CLR	C	Clear numeric entry to zero

APPENDIX A  
OPTION 9200B-01B

A-12. (Continued).

f. IEEE-488 Bus Command Extensions. The following functions are added to bus operation:

Name	GPIB	Function
ADR.ZERO	Y	Zero selected ranges (0-7)
SET RANGE	G	Set to selected range (0-7)

These commands must be preceded by an appropriate argument. The argument for Y is the span of ranges to be zeroed; for example: 26Y specifies zeroing of ranges 2 through 6. If only one range is to be zeroed, the argument must begin and end with the same code (e.g., 11Y to zero only range 1). The argument for G is the range number (0 = 1 mV to 7 = 3000 mV for 9200B probes) to be set.

g. Bus Availability. When the Model 9200B is sent a string, it does not normally tie up the bus while responding to the string; other bus communications are possible during the interval. The 9200B can inform the controller when it is finished by use of the Service Request (see A-12d, above), if this is desired.

The Model 9200B can, however, be made to lock up the bus while it is responding to a string - if such action is desired - by sending it two strings in succession (even if the second string is only a Null command).

Example: A "zero" command: wrt 716,"Z"  
Followed by a "talk" command: red 716,A,B,C

A-13. REMOTE PROGRAMMING.

NOTE

It is assumed that the user is acquainted with GPIB principles and terminology. Refer to the controller instruction manual for the syntax needed to create specific bus commands and addressing sequences. All examples given apply to the HP 9825 calculator.

A-14. Bus Programming Syntax. The bus programming syntax mirrors the front-panel keystroke sequence closely. Each key has been assigned an alphanumeric character, and sending that character is equivalent to pressing that front-panel key. The resulting operation is indistinguishable from local control.

Numerical values are translated by the GPIB interface so that commonly observed formats may be used. Fixed formats and floating-point formats may both be used. These representations are converted to their equivalent fixed-point values, and the sign information is post-fixed automatically, thereby ensuring that natural notations for numbers will be accepted by the instrument.

A-15. Suppose that it is desired to set the instrument to the mV mode. The HP 9825 calculator could be programmed: wrt 716,"P"

The "wrt" instructs the calculator to send data on the bus to one or more listeners. The number following is the address information; 7 is the calculator address and 16 is the instrument address. (All examples in this appendix will use 16 as the instrument address, although any valid address can be assigned to the instrument.) When the calculator interprets the first part of the line, it will assert the ATN line to signify that commands or addresses will be sent on the bus. Following that, it will send three bytes or characters: Unlisten, the calculator Talk Address and the instrument Listen Address. This information will configure both the calculator and the instrument for the data transfer. After the last command byte has been accepted, ATN will be released to the false state by the calculator. All information on the bus is interpreted as data in this mode. While in the data mode, the calculator will send the character "P" to the instrument. At this instrument, this will be interpreted as equivalent to pressing the MODE mV key and that function will be executed. Because there is no more data to be sent, the calculator will send a delimiter (the preselected message terminator, see Table A-2). The instrument recognizes the message terminator as an end-of-message signal and returns to the bus idle condition.

A-16. The preceding discussion of the sending of a single programming byte serves to illustrate two important points: every data transfer is preceded by a command/address preamble and each transfer is terminated by a message terminator (see Table A-2). In the preceding example, six characters were sent on the bus; only one was a programming byte.

A-17. The measurement mode functions (P, B, A, O, V, D, W) and the special functions (Z & C) do not expect any numeric value. These functions all are executed as received. For example: the following will program dBmV and autorange mode:

```
wrt 716,"BA"  
or  
wrt 716,"AB"
```

Note that the sequence is unimportant, except that each function is executed in the order it is received on the bus.

A-18. Suppose that the instrument is to be zeroed automatically and then asked to send the reading in the mV and RANGE AUTO modes. The HP 9825 calculator could be instructed as follows:

```
wrt 716,"APZ"  
red 716,V,S,Y
```

The automatic zeroing cycle time is approximately 18 seconds. Until zeroing is completed, the instrument is unable to respond with new data. The first line of the preceding instructions sets the operating mode and initiates the zeroing cycle. The last line reads the response from the instrument. The instrument response consists of three numeric values: the first value is the

A-18. (Continued).

front panel reading, the second is a status value (normally zero) and the third is the range. These three numbers will be stored in the calculator variable (storage locations) V, S and Y. Note that each data transmission from the instrument consists of three values. When the status value is non-zero, indicating an error condition, the data value will be set to zero. The program will normally test the status value to assure valid operating conditions.

A-19. Store/Recall Functions Syntax. The general syntax for store/recall functions is the same as the front panel sequence; if a numeric value immediately precedes the function, that value will be stored; otherwise, the existing stored value will be recalled to the front panel. These functions (L, H, N, R, I, X) thus operate in a dual mode.

A-20. Suppose that it is desired to store the current voltage level in dB into the dB reference so that all future readings will be referred to the current value. Allowance must be made for the possibility that the current value is a dB relative value. To do this, the current dB value must be read, the existing dB reference must be recalled, the true dB value must be computed and this value must be stored into dB reference. The calculator could be instructed as follows:

```
red 716,V,S,A
wrt 716,"R"
red 716,X,S,A
V+X+Y
wrt 716,Y,"R"
```

Note that R is used twice in the program, the first time to obtain the existing value for the dB reference and the second time to store the computed value. Also, note that the two read statements (red) each fetch a different value; the first value is the voltage value in dB and the second is the dB reference.

A-21. Output Data Format. The data output of the instrument consists of a string containing voltage measurement mode, channel in use, front panel display, status of measurement and the range code. The following format is used:

```
abcdsdEsd,S,R,(cr)(lf)
```

Where:

ab = mode (MV = voltage in mV; DM = dBmV mode;  
DR = dB reference mode; DV = dBV mode;  
DB = dB mode; DW = dBW n and E) (?)  
c = channel (A = 1; B = 2; C = 3)  
s = sign (+ or -)  
dddd = data (four digits, each digit 0 through 9)  
Esd = exponent, sign, digit  
, = data delimiter  
S = status digit:  
0 = no error  
1 = entry too small  
2 = entry too large  
3 = measurement underrange  
4 = measurement overrange

5 = zero acquisition out of range  
- excessive negative offset  
(hardware malfunction, e.g.,  
input connector polarity reversed;  
negative chopper offset)

6 = zero acquisition out of range  
- excessive positive offset  
(input too large)

7 = channel 3 over/under range

R = range digit

0 = 1 mV

1 = 3 mV

2 = 10 mV

3 = 30 mV

4 = 100 mV

5 = 300 mV

6 = 1000 mV

7 = 3000 mV

cr = carriage return

lf = line feed

A-22. Hold Measurement Function Syntax. The hold measurement function will hold the current instrument measurement and prevent another measurement until otherwise commanded. The syntax for hold is IQ and for unhold (return to normal measuring) is OQ.

NOTE

If a command is sent during the hold measurement mode, the instrument display will not return to the previous measurement displayed.

A-23. SRQ Function Syntax. The controller can command the instrument to pull the SRQ line true after each measurement. The syntax for this command is 1S, 2S, to command the instrument not to pull the SRQ line true after each measurement, the syntax is 0S. To command the instrument to pull the SRQ line true after each settled reading the syntax is 2S.

A-24. Measurement Trigger Syntax. A T command on the interface bus will force an instrument measurement. This command is identical to the IEEE-488 bus Group Execute Trigger command.

A-25. Typical Application. Suppose that it is desired to measure insertion loss or gain with an instrument equipped with option 92008-03, where channel 2 measures input voltage and channel 1 measures output voltage. The program shown below will request reference conditions and wait for the user to set them up. Following establishment of the reference, the program will loop on insertion loss/gain measurements. Each measurement is triggered by the user. Zeroing is prompted in the local mode at the beginning of the program. Reading errors, should they occur, will be signalled by a double beep from the calculator; normal measurements will give a single beep. There will be one print line per measurement. The reference value is not printed in this example.

Program Variable Usage:

P: = voltage measurement value

S: = status value

Z: = dummy input for prompts

R: = range value

APPENDIX A  
OPTION 9200B-01B

A-25. (Continued).

Program Statements	Comments
0: cll 7	Clear interface
1: ent"zero chl,2",Z	Prompt for zeroing
2: rem 7	Enable remote
3: wrt 716, "1NAOR2NAOR3N"	0 dB ref, auto-set ch 3
4: ent"ref measure",Z	Prompt to set up ref
5: red 716,P,S,R	Read ref value, status
6: if S>0;dsp"error", S;beep, gto4	Test status
7: wrt 716,"1N",P,"R3N"	Set ch 1 dB ref = P
8: beep;ent "measure",Z	Prompt for measurement
9: red 716,P,S,R	Read measurement, status
10: if S>0;dsp"error",S; beep; wait 100; gto8	Test status
11: prt P, "dB"; gto8	Print measurement
12: end	

A-26. The program in the preceding paragraph also measures reflection coefficient if channel 1 measures reflected voltage and channel 2 measures incident voltage. The reference conditions are established with a short at the test port of the directional coupler.

A-27. Use of Hold Measurement Command (Q), Trigger Command (T) and Measurement-Complete-SRQ Commands (V). An example of the use of these commands using an HP Model 85 controller, BEC Model 1020 generator and the BEC Model 9200B RF Voltmeter follows:

Statement	Comment
10 I TOSCHK	Program name
20 REMOTE 7 @ CLEAR	Enable remote; clear display
30 OUTPUT 703 ;"1N 501GR0000SAD"	Set model 9200B; ch 1, sensor 1, $Z_0 = 50 \Omega$ , 0 reference dB, no hold indication, no measurement-complete- SRQ, auto range mode, dB display mode
40 OUTPUT 702 ;"1MH0L00N"	Set model 1020; 1 MHz, output level of 0 dBm, output on
50 OUTPUT 703;"1Q"	Set model 9200B to hold-indication mode

60 OUTPUT 702 ;"OL-10"	Set model 1020 to -10 dBm level
70 ENTER 703; A	Read model 9200B; store in A
80 PRINT A	Print model 9200B indications (A)
90 DISP"PRESS CONTINUE FOR T C COMMAND"	Display prompt on model 85
100 PAUSE @ BEEP	Stop program; issue beep (press continue)
110 OUTPUT 703; "T"	Send T (trigger command to model 9200B
120 ENTER 703; A	Read model 9200B indication; store in A
130 PRINT A	Print model 9200B indication
140 OUTPUT 703;"0Q"	Set model 9200B for no hold-indication auto range mode, dB mode
150 DISP"PRESS CONTINUE FOR 1S COMMAND"	Display prompt on model 85
200 PAUSE @ BEEP	Stop program; issue beep
210 OUTPUT 702;"0L0"	Set model 1020 to dBm output
220 WAIT 1000	Wait 1 second for settled indication on 9200B
230 ON INTR 7 GOTO 290	If interrupt occurs, branch to 290
240 OUTPUT 703;"1S"	Set model 9200B to issue an SRQ at completion of measure- ment
250 WAIT 200	Wait 0.2 seconds
260 ENABLE INTR 7;8	Enable SRQ interrupt in model 85
270 ON TIMER# 1,5000 GOTO 370	If no interrupt is received in 5 seconds, branch to 370
280 GOTO 280	Wait for interrupt (or escape after 5 seconds - step 270)
290 OUTPUT 703;"0S"	At interrupt, set model 9200B to no- measurement-complete SRQ
295 WAIT 200	Wait 0.2 seconds
300 S=SPOLL(703)	Store result of serial poll of model 9200B in S

A-27. (Continued).

Statement	Comment
310 IF BIT(S,6)<>1 THEN GOTO 370	If bit 6 (SRQ bit) of model 9200B service request byte does not =1, go to 370
320 PRINT "MEAS-COMP-SRQ"	If bit 6 does =1 (SRQ bit) print "MEAS-COMP-SRQ"
340 DISP"PRESS CONTINUE FOR OS COMMAND"	Display prompt on model 85
350 PAUSE @ BEEP	Stop program; issue beep
360 GOTO 260	Go to 260
370 PRINT"NO MEAS- COMP-SRQ"	There has been no service request
380 PRINT "DONE"	Check is complete; print "DONE"
390 END	

A-28. In the above example, the addresses of the devices are:

Device	Address
HP Model 85B	7
BEC Model 1020	7
BEC Model 9200B	2

A-29. The sequence of events in the example program are as follows:

HP Model 85 Controller	Comments
RUN	The model 9200B will read the signal generator level of approximately 0 dBm and this will be printed by the model 85B; the model 1020 will change its level to -10 dBm, but the model 9200B will not change its indication since it is in the hold-indication mode; program stops at pause and waits for continue on model 85.
CONTINUE	This issues a T (trigger) command to the model 9200B, which now changes to approximately -10 dBm; this is printed by the model 85. The program stops and waits for continue.
CONTINUE	This initiates a sequence in which the measurement-complete-SRQ is enabled.
CONTINUE	This initiates a sequence in which the measurement-complete-SRQ has been disabled.

A-30. Sealed System Operation. When in sealed system operation (selected by the control board bit switch) the instrument will power up in the operate mode but, by the use of the proper GPIB commands this instrument can be placed in the DC or AC modes to allow calibration of the instrument over the bus without removal from the system rack. The GPIB commands are:

Operate Mode	"80m"
Calibrate Mode 1 (DC Cal)	"81m"
Calibrate Mode 2 (AC Cal)	"82m"

A-31. THEORY OF OPERATION.

A-32. General. Interface board A23 is a microprocessor-driven data interface which converts IEEE 488 bus compatible signals into control codes that operate the internal control bus of the instrument. It also converts instrument data into IEEE 488 compatible signals for use on the bus. All data transfers are handled by source and acceptor protocols defined by IEEE-488-1975.

A-33. Detailed Description. (See Figure A-1) All data manipulation and IEEE-488 bus management are controlled by CPU A23U7 in conjunction with a micro-program stored in PROM A23U8. All data transfer is handled in parallel to parallel mode by adapter A23U16. Latch A23U15 handles transfer of bit switch data that defines the instrument address and message termination characters to the instrument data bus. BI-directional buffers A23U17 and A23U18 handle data and control signal transfers, respectively, between adapter A23U16 and the interface buses. The Ram memory A23U11 is used by the CPU for temporary storage of program variables during program execution. A23U14 the program timer is only used by the -06 MATE option for timing required under CIL operation. A23U1 and A23U2 the programmable peripheral interfaces form a "mailbox" for data transfer between the instrument and interface address, control, and data buses.

A-34. When the instrument is turned on, or when the supply voltage goes low, the supply voltage supervisor A23U5 keeps the reset line active until the power supply voltage has reached its nominal voltage value, thereby resetting the CPU A23U7 and clearing the adapter A23U16.

A-35. Instrument address and message termination character data that is preset by bit switch A23S1 is supplied to latch A23U15. To read the switch data, address bits AB4, AB5, and control signal TORD are activated producing signal BSW and enabling the latch output. The switch data is then transferred through the latch to the interface data bus.

A-36. To read incoming interface control signals, the CPU activates signals TORD and sets address bit AB4 low. The interface control signal port of adapter A23U16 is selected through address bits AB0, AB1, and AB2. Adapter A23U16 is enabled through decoder A23U12. Because signal TORD is

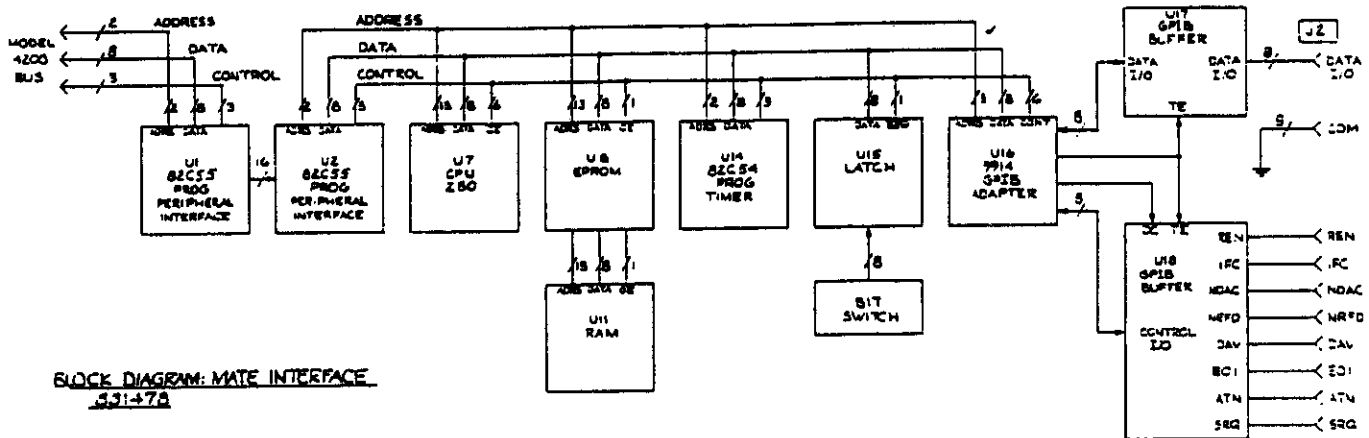

Figure A-1. IEEE-488 Bus Interface Option 9200B-01B Block Diagram

A-36. (Continued).

active, signal TE supplied by the adapter to buffer A23U18 is inactive and this buffer is set up for data transfer from the interface control signal bus to the control signal port of adapter A23U16. Incoming interface control signals are transferred through buffer A23U18 and adapter A23U16 to the instrument data bus. Clocking of adapter operations is controlled by the clock signal ZCLK which is generated by A23U4b and divided by A23U6. ZCLK also supplies the required clock to the CPU A23U7. Interface control signal transfer in the opposite direction is achieved by reversing the states of signals TORD and TOWR. An active TOWR causes signal TE to buffer A23U18 to become active, thereby reversing the direction of data flow through the buffer. Interface control signals from the interface data bus are then written onto the interface control bus through adapter A23U16 and buffer A23U18.

A-37. To handle data transfers between the interface data bus and the interface connector A23J2, adapter A23U16 is similarly enabled through decoder A23U12 by low address bit AB4. Address bits A0, A1, and A2 are set to select the data port of adapter A23U16, and signals TOWR and TORD specify the write and read functions. If data is to be written to the interface connector A23J2 signal TOWR is activated, thereby activating signal TE to buffer A23U17. Data on the interface data bus is then transferred through adapter A23U16 and buffer A23U17 to connector A23J2. For data transfers from connector A23J2 to the interface data bus, signal TORD is inactive and signal TOWR is active. Signal TE to buffer A23U17 is deactivated by adapter A23U16 to reverse the direction of data transfer through the buffer.

A-38. MAINTENANCE.

A-39. General. The interface board does not operate alone, but rather in conjunction with the Model 9200B. If interface operation becomes abnormal it should first be determined if the 9200B operates normally without the interface. If it does, proceed according to the following paragraphs.

A-40. Physical Inspection. Check the interface board visually for loose or broken connectors, unseated IC's, foreign material, etc.

A-41. Voltage Checks. With the board installed in the 9200B, and all connectors in place, check the supply - and IC - voltages according to the values shown on the schematic diagrams, Figures A-2, A-3, and A-4.

A-42. Active-Device Substitution. All the active devices are socketed, making replacement simple. Replace each device, one at a time, and check for restoration of proper performance by the instrument.

A-43. Troubleshooting. An oscilloscope, while not the most useful tool for troubleshooting bus-oriented microprocessor systems, still may be used to determine activity or lack of activity on the address, data and control lines.

A-44. REPLACEABLE PARTS.

A-45. Table A-5 lists all the replaceable parts and includes; Reference Symbol, Description, Mfr., Mfr's Part No., and the BEC Part No.

A-46. SCHEMATICS.

A-47. Refer to Figures A2, A3, and A4 for the schematics for the 9200B-01B Option.

TABLE A-5. REPLACEABLE PARTS.

04223500A		PWA INTERFACE			
REFERENCE DESIGNATOR	DESCRIPTION	FED. CODE	MANUFACTURER PART NUMBER	QTY	BEC PART NUMBER
A	CONNECTOR 2 PIN STRAIGHT	27264	22-03-2021	1	477361000
B	CONNECTOR 2 PIN STRAIGHT	27264	22-03-2021	1	477361000
C1	CAP MICA 47PF 5% 300V	20307	DMS-EC470J	1	205018000
C2	CAP TANT 10UF 10% 35V	56299	1960106X903PE4	1	293353000
C3	CAP CER 0.1UF 20% 50V	04222	SR215E104MAA	1	224268000
C6	CAP EL 10UF 20% 25V	64217	SM-25-V8-10-M	1	293356000
C7-12	CAP CER 0.1UF 20% 50V	04222	SR215E104MAA	6	224268000
J2	CONNECTOR 24 PIN (GP1B)	32575	552230-1	1	479350000
P1	(G) CONNECTOR 5 PIN RT ANG MOD	04901	47733300A	1	47733300A
R1	RES MF 1.00M 1% 1/4W	14674	5043ED1M000F	1	341600000
R2	RES MF 20.5 OHM 1% 1/4W	19701	5043ED20R50F	1	341130000
R3-4	RES MF 4.75K 1% 1/4W	19701	5043ED4K750F	2	341365000
RA1	RES NETWORK 4.7K 2% 1.8W	01121	3168472	1	345020000
RA2	RES NETWORK 22K 2% 1.7W	01121	4088223	1	34504412A
S1	SWITCH DIP SPST 8 CKT PIANO	LAMB	BT-8-2	1	46529908A
U1-2	IC 82C55 INTERFACE	34371	CP82C55A	2	53441100A
U3-4	IC 74HC04 HEX INVERTER	02735	CD74HC04E	2	53442504A
U5	IC 7705 SUPPLY VOLTAGE SUPVP	01295	TL7705ACP01295	1	53442200A
U6	IC 74HC74 DUAL D TYPE FLO	02735	CD74HC74E	1	53442502A
U7	IC 280C CPU CMOS	TOSHIB	TMP284C00AP	1	53440900A
U9-10	IC 74HC32 QUAD 2 INPUT OR	02735	CD74HC32E	2	53442501A
U11	IC 5564 8Kx8 RAM CMOS 28 DIP	TOSHIB	TC5564PL-15	1	534403000
U12	IC 74HC139 DUAL 2-4	02735	CD74HC139E	1	53442500A
U15	IC 74HC240 OCTAL BUS	02735	CD74HC240E	1	53442503A
U16	IC 9914ANL IEEE BUS PROCESSOR	01295	TM9914ANL	1	534288000
U17	IC 75160 IEEE BUS TRANSCEIVER	01295	SN75160BN	1	534286000
U18	IC 75161 IEEE BUS TRANSCEIVER	01295	SN75161BN	1	534287000
XU1-2	SOCKET IC 40 PIN	06776	ICN-406-S4-TG	2	473052000
XU3-4	SOCKET IC 14 PIN	06776	ICN-143-S3-G	2	473019000
XU5	SOCKET IC 8 PIN	06776	ICN-083-S3-G	1	473041000
XU6	SOCKET IC 14 PIN	06776	ICN-143-S3-G	1	473019000
XU7	SOCKET IC 40 PIN	06776	ICN-406-S4-TG	1	473052000
XU8	SOCKET IC 28 PIN	06776	ICN-286-S4-TG	1	473044000
XU9-10	SOCKET IC 14 PIN	06776	ICN-143-S3-G	2	473019000
XU11	SOCKET IC 28 PIN	06776	ICN-286-S4-TG	1	473044000
XU12	SOCKET IC 16 PIN	06776	ICN-163-S3-G	1	473042000
XU14	SOCKET IC 24 PIN	06776	ICN-246-S4-G	1	473043000
XU15	SOCKET IC 20 PIN	06776	ICN-203-S3-G	1	473065000
XU16	SOCKET IC 40 PIN	06776	ICN-406-S4-TG	1	473052000
XU17-18	SOCKET IC 20 PIN	06776	ICN-203-S3-G	2	473065000
Y1	CRYSTAL 3.579545 MHz	EDMAR	MDC035A	1	547035000



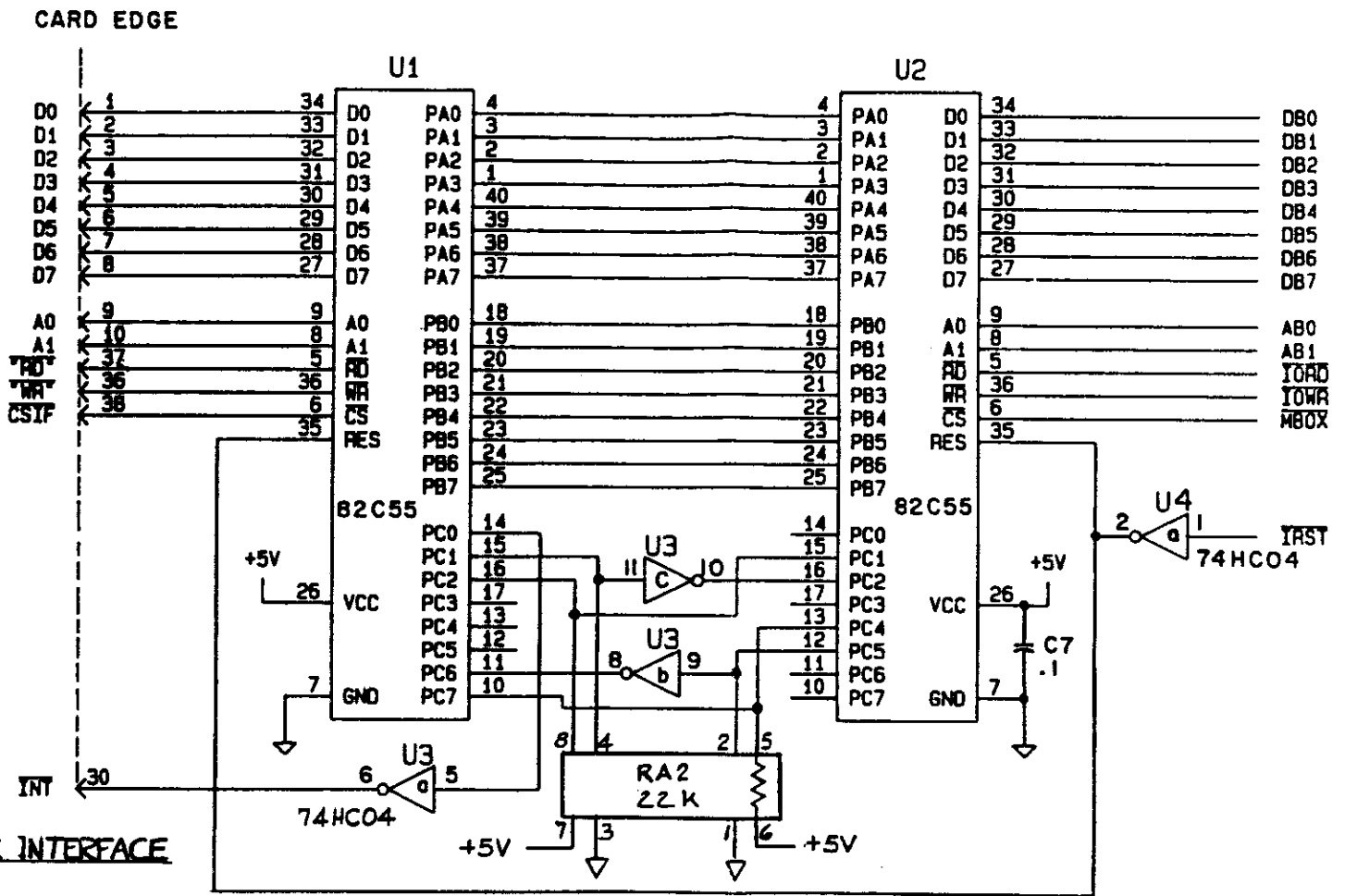
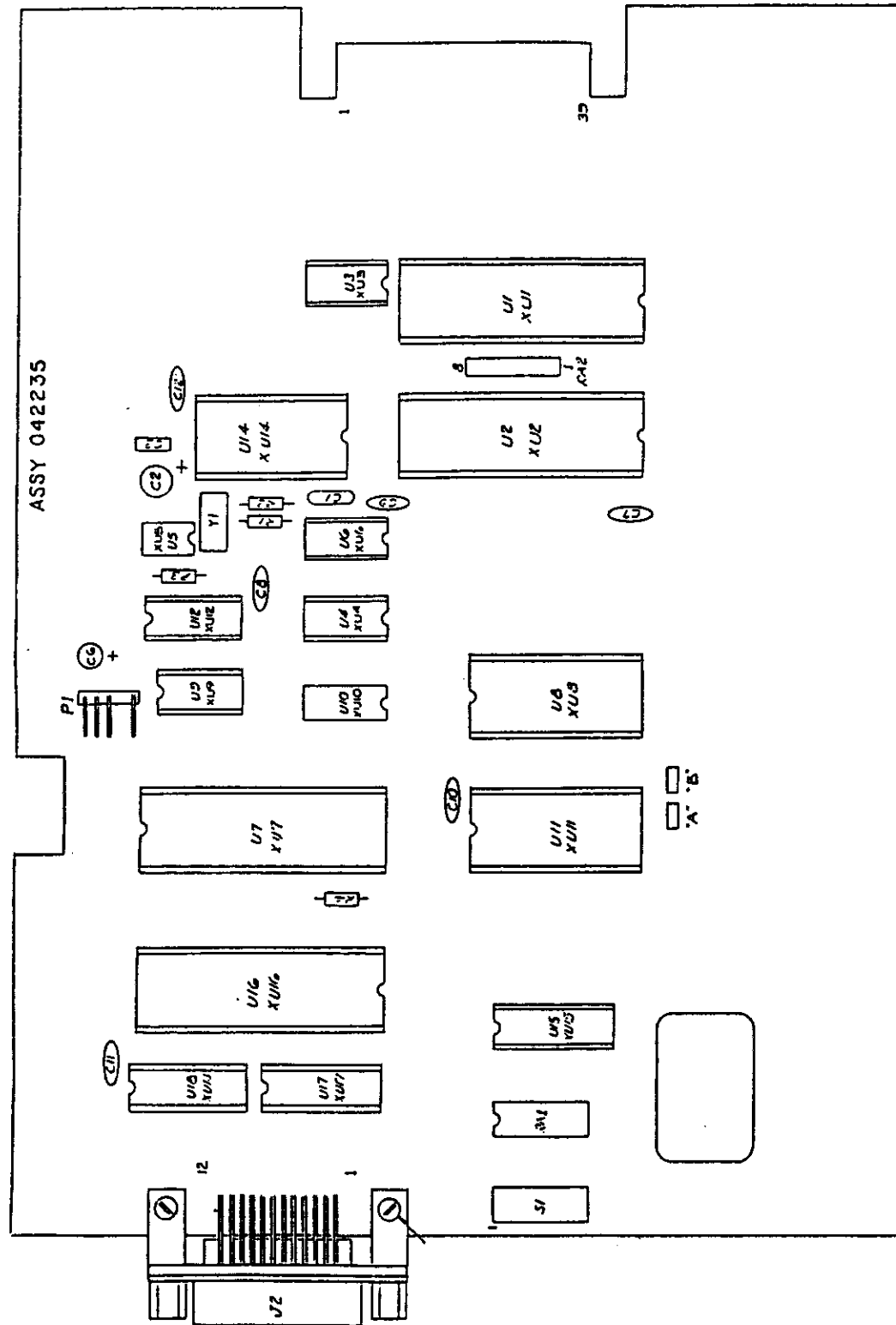

SCHMATIC MATE INTERFACE  
831459 OIA

- NOTES:**
1. CAPACITOR VALUES IN UF UNLESS OTHERWISE SPECIFIED.
  2. RESISTANCE VALUES IN OHMS UNLESS OTHERWISE SPEC.
  3. USE JUMPER "A" WHEN U11 IS A 2K ROM.  
USE JUMPER "B" WHEN U11 IS A 8K ROM.
  4. LAST NUMBER USED: R8, C12, U18, J4  
NUMBERS NOT USED: R5, R6, R7; C4, C5; U13.

Figure A-2. A23 Interface PC Board Schematic  
and Component Location Diagram  
Sheet 1 of 3

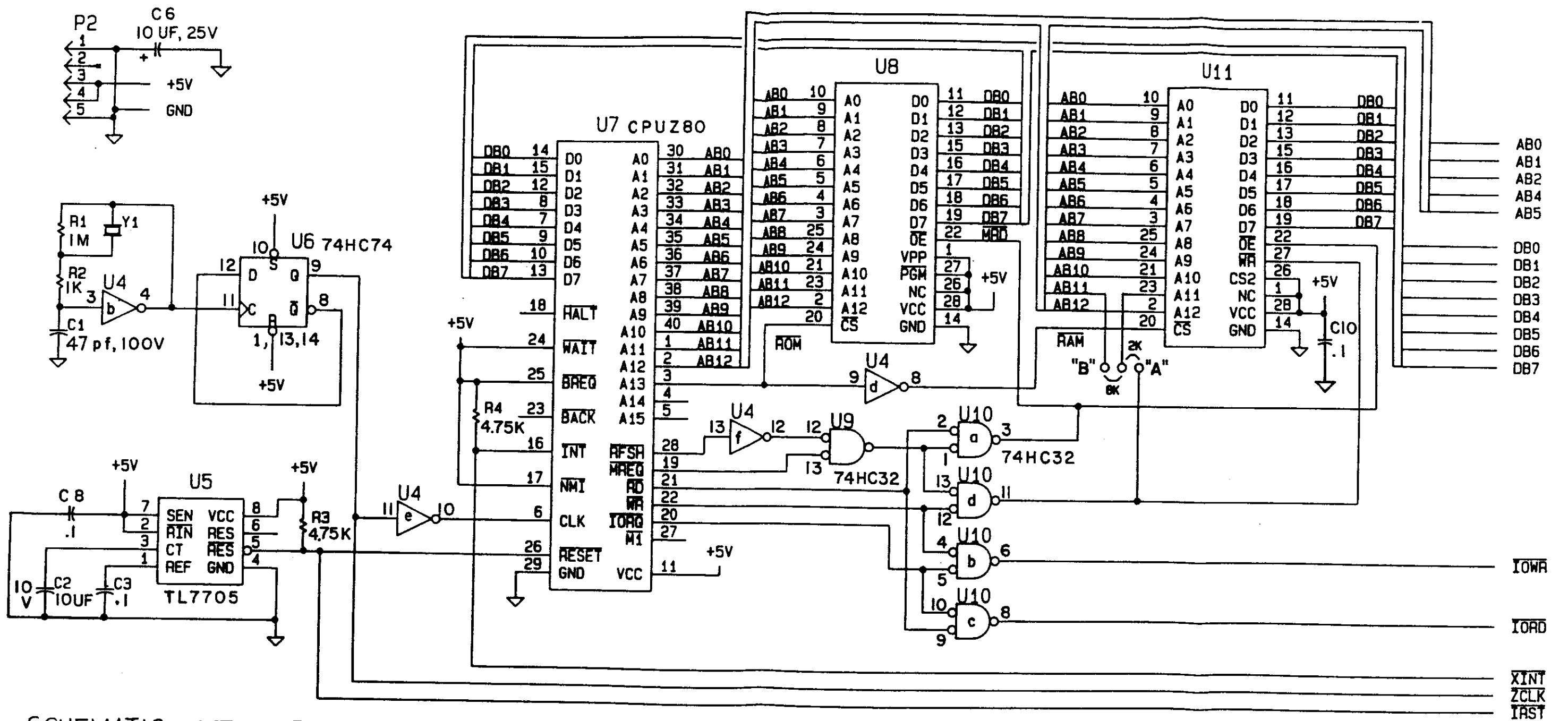

SCHEMATIC, MATE INTERFACE  
83145902A

Figure A-3. A23 Interface PC Board Schematic  
Sheet 2 of 3

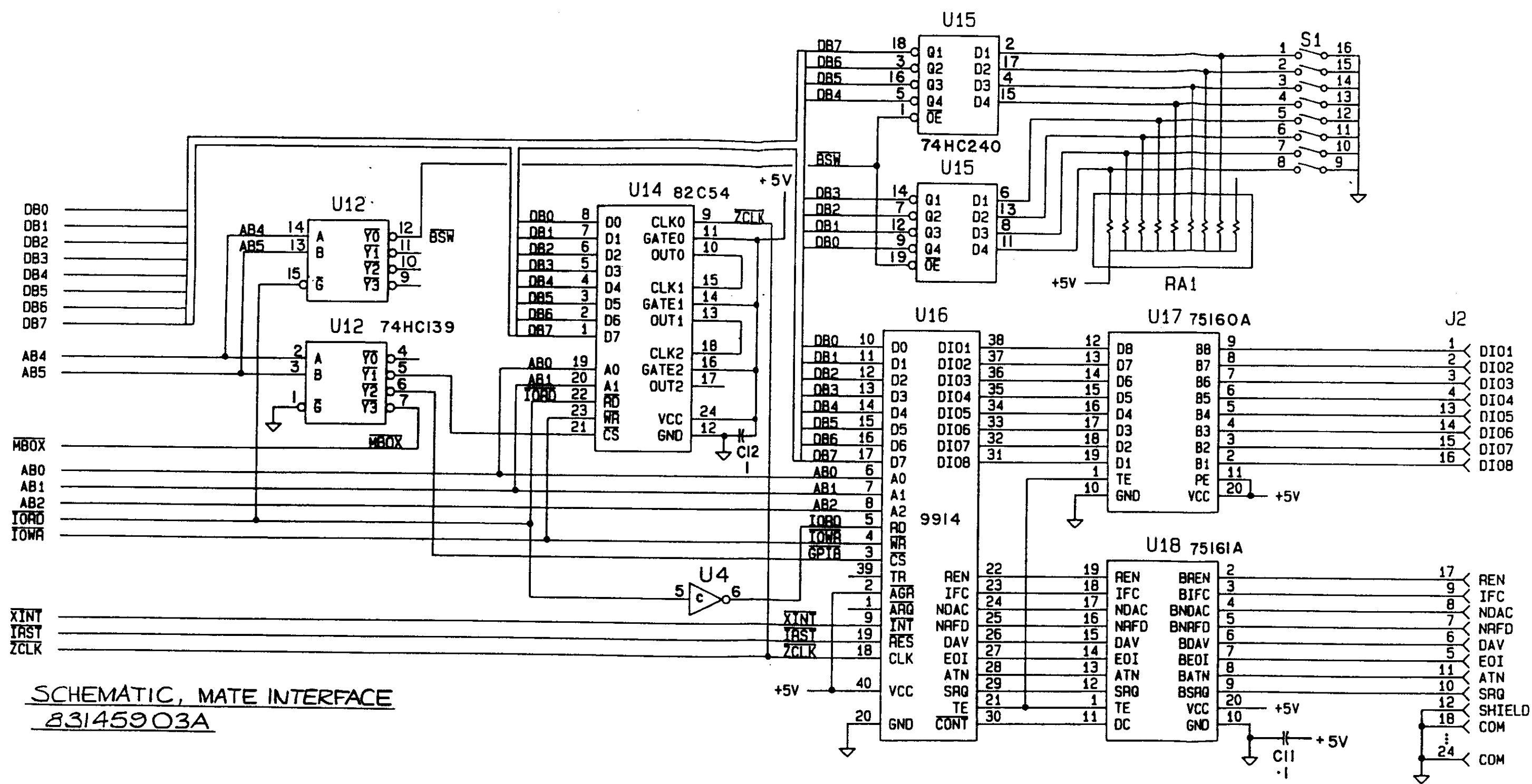

SCHEMATIC, MATE INTERFACE  
83145903A

Figure A-4. A23 Interface PC Board Schematic  
Sheet 3 of 3

APPENDIX B  
INPUT CHANNEL 2  
OPTION 9200B-03

B-1. DESCRIPTION.

B-2. Option 9200B-03 provides an additional measurement channel (channel 2) that is identical to channel 1 except for mounting. With this option installed, measurements may be made on each channel individually, or both channels can be monitored automatically and their difference in dB displayed. This option consists of a second input module, complete with chopper, that connects to the 40-line bus and has its own power connector. Connections are shown in Figure 7-9.

B-3. INSTALLATION AND REMOVAL.

B-4. To install and remove the input channel 2 option, proceed as follows:

- a. Turn the instrument bottom up. Remove the screws that secure the bottom cover and slide the bottom cover back and off.
- b. Install the rear input connector at the left side of the rear panel.
- c. Dress the cable from the rear input connector down the left side frame of the instrument (as viewed from the bottom of the instrument) and across the front sub-panel. The cable will run below the module being installed.
- d. Remove the bottom trim strip from the instrument by removing the two screws that secure it to the sub-panel. Install the second channel front panel input connector observing the same orientation as the channel 1 connector. Secure the cable grounding lug under the left binder-head screw that holds the connector mounting bracket to the sub-panel. Run the wire from the rear connector and chopper through the open slot in the sub-panel and wire the input connector the same as channel 1. Re-install the bottom trim strip.
- e. Install the channel 2 input module and secure it to the side frames of the instrument with the four screws supplied with the option.
- f. Remove the four corner screws that secure the channel 2 input module cover and remove the cover.
- g. Plug the channel 2 chopper into the channel 2 input module, seating the chopper firmly.
- h. Connect the 40 pin ribbon cable connector to the front edge connector of the channel 2 input module.
- i. Connect the power cable supplied to the power supply (position B) with the black lead on the right side (as viewed from the bottom of the instrument) and to the input module (rear) with the black lead on the right.

NOTE

Avoid reversal of the two ends of this cable; there is lead trans-position.

j. Install the channel 2 input module cover that was removed in step f.

k. Replace the bottom cover removed in step a.

l. To remove the channel 2 input module, reverse the above procedure.

B-5. OPERATION.

B-6. When option 9200B-03 is installed, each input channel may be operated independently with its own probe. Probe data and measurement parameters stored in the instrument non-volatile memory for each of the two input channels are selected automatically when the associated channel is selected.

NOTE

When programming measurement parameters for a channel, the channel number must be the first item selected.

B-7. Channel 1 and channel 2 operating procedures are basically the same as those described in Section III of this manual. A channel 3 mode of operation may also be selected. In the channel 3 mode, the input levels to channels 1 and 2 are both monitored, and the difference between the two inputs, (in dB referred to channel 2), is shown on the instrument display. The following parameters selected for channels 1 and 2 prior to selection of the channel 3 mode remain operative for channel 3 mode operation:

- a. Autoranging or range hold (for each channel).
- b. Limits (for each channel)
- c. dB reference levels (for each channel)
- d. Zeroing

B-8. When channel 3 mode has been selected, the following keys are inactive:

- a. ZERO
- b. MODE mV
- c. MODE dBm (instrument is automatically in this mode).
- d. X100
- e. REF LEVEL dB
- f. AVERAGE SELECT

The recorder output in channel 3 mode is a function of channel 1 dB only.

B-9. MAINTENANCE.

B-10. The procedures used to isolate malfunctions to the channel 2 input module are similar to those described for the channel 1 input module in Section V of this manual. Signature analysis techniques are used to isolate defective parts on the channel 2 input module. For convenience, the signature analysis information for the channel 2 input module is included in Section V.

APPENDIX C  
INTERNAL TMA (MATE)  
OPTION 9200B-06

C-1. DESCRIPTION.

C-2. The 9200B-06 option provides IEEE-488 programming syntax which conforms to MATE System Control Interface Standard. The protocol is the CIIIL subset of the ATLAS control language.

C-3. The 9200B-06 option consists of the following items:

- a. A23U8, P/N 53443200B replaces the existing A23U8 P/N 53444100B.
- b. A23U14, P/N 53441000A.
- c. A51C6, P/N 53443000B replaces the existing A51C6 P/N 53443900B.
- d. A51C7, P/N 53443100B replaces the existing A51C7 P/N 53444000B.

C-4. MATE CONFIGURATION.

C-5. The 9200B-06 option allows two main modes of operation, selected by Bit Switch 8 of the Interface Board Bit Switch, S1.

	Bit Switch No.								Operating Mode
	8	7	6	5	4	3	2	1	
C	-	-	-	-	-	-	-	-	Native (non-MATE) IEEE-488 control
O	-	-	-	-	-	-	-	-	MATE compatible IEEE-488 control

C = closed (Logic 0)  
O = open (logic 1)  
- = as required

C-4. The MATE/native mode selection is made during power-on initialization. To change mode, the instrument must be turned off before Bit Switch 8 is changed. When power is re-applied, the new mode will be in effect.

C-5. When the 9200B-06 powers up in the MATE compatible mode, the active channel is set to the following conditions:

- a. Millivolt Mode
- b. Autorange Mode
- c. High dB Limit = 99.99
- d. Low dB Limit = -99.99
- e. Raw data flag cleared

C-6. While the 9200B-01B is in IEEE-488 LOCAL mode, all panel functions are available to the operator. This includes all of the conditions preset during power-up. When the system controller places the 9200B-01B into the REMOTE mode, the above initializations will be restored. All panel controls are inoperative while the 9200B-01B is in REMOTE mode.

C-7. The 9200B-01B option supports two-channel operation if the second-channel hardware is installed. Attempts to access a non-existent channel will generate an illegal channel error message. The first channel is addressed as :CH0 or :CH00, and the second as :CH1 or :CH01.

C-8. OPERATION.

C-9. Users of this option must be familiar with the mate standard. Only the specific CIIIL commands and protocols applicable to the 9200B are discussed in this appendix.

C-10. A MATE measurement consists of the following operations:

- a. SETUP FNC command
- b. CLOSURE CLS command
- c. INITIATION INX command
- d. RESULT FETCH FTH command
- e. DISCONNECT OPN command
- f. RESET RST command

C-11. Each of the first three steps (SETUP, CLOSURE and INITIATION) must be done in that sequence. An error message will be generated if the requisite prior steps have not been successfully performed.

C-12. SETUP.

C-13. The SETUP command syntax is as follows:

FNC ACS VOLT :CHn (optional limits) <cr><lf>

where :CHn = :CH0, :CH00, :CH1, or :CH01  
<cr> = ascii return, <lf> = ascii line-feed

C-14. If no optional limits are sent, the default values will be set:

Maximum voltage = 3,000 Volts  
Minimum voltage = 0,000 Volts  
Maximum frequency = 1,200 Gigahertz  
Maximum delay time = 3,000 seconds

C-15. Each limit may be optionally set within the FNC command string. Any limit not set will retain its default value:

Command	Comment
SRX VOLT value	Max voltage: range = Vmin to 3,000 Volts
SRN VOLT value	Min voltage: range = 0 Volts to Vmax
SET VOLT AUTO	Leave max = 3 volts, and min = 0 volts
SET FREQ value	Max frequency: range = 0 to 1.2 GHz

Note: value = ascii numeric string, fixed or floating point.

APPENDIX C  
OPTION 92008-06

C-16. If no error is detected while parsing the FNC string, the active channel will be set as determined by the :CHn modifier, and the limit values will be effective until a new SETUP or a RESET occurs.

C-17. The following messages may be generated while parsing the SETUP command:

- a. No error: <sp><cr><lf>
- b. Unrecognized operand: F07HFV0n (MOD): ILLEGAL NOUN/NOUN MOD, zzz<cr><lf>
- c. Operand out of sequence: F07HFV0n (MOD): ILLEGAL zzz PROGRAMMED H.F. VOLTMETER <cr><lf>
- d. Missing operand(s) at end of command: F07HFV0n (MOD): ILLEGAL SYNTAX PROGRAMMED H.F. VOLTMETER <cr><lf>
- e. Improper channel command: F07HFV0n (DEV): ILLEGAL CHANNEL PROGRAMMED H.F. VOLTMETER <cr><lf>
- f. Maximum voltage out of allowable range: F07HFV0n (DEV): ILLEGAL MAXIMUM PROGRAMMED H.F. VOLTMETER <cr><lf>
- g. Minimum voltage out of allowable range: F07HFV0n (MOD): ILLEGAL MINIMUM PROGRAMMED H.F. VOLTMETER <cr><lf>
- h. Frequency limit out of allowable range: F07HFV0n (DEV): ILLEGAL FREQUENCY PROGRAMMED H.F. VOLTMETER <cr><lf>
- i. Maximum delay time out of allowable range: F07HFV0n (MOD): ILLEGAL MAXTIME PROGRAMMED H.F. VOLTMETER <cr><lf>

Notes:

1. <sp> = ascii space.
2. n = 0 or 1.
3. zzz = unrecognized or illegal operand, truncated to 20 char.
4. Errors b, c and d are general syntax errors, and may occur during any improperly constructed command string. In the sections that follow they will be termed "syntax errors", and will not be separately shown.

C-18. CLOSURE.

C-19. After successful SETUP, the 92008 must be CLOSED. The command syntax is:

CLS :CHn<cr><lf>

C-20. The channel number must agree with the current active channel, as set by the FNC command string. If it does not, an illegal channel message will be generated.

C-21. In addition to syntax errors, the following messages may be generated:

- a. No error: <sp><cr><lf>
- b. Improper channel command: F07HFV0n (DEV): ILLEGAL CHANNEL PROGRAMMED H.F. VOLTMETER <cr><lf>

c. Instrument not SETUP: F07HFV0n (MOD): H.F. VOLTMETER NOT SETUP <cr><lf>

C-22. INITIATION.

C-23. Each measurement must be INITIATED before any result can be obtained. The command syntax is:

INX VOLT <cr><lf>

C-24. If no error condition is encountered while parsing the above command, the 92008 computes the time required to complete the measurement and places the time in the output buffer. The output buffer is enabled, and the controller is expected to read this value and use it to determine its I/O timeout limit.

C-25. A measurement is then initiated. During this time, the 92008 is able to accept the follow-on FTH command string, but will not return data until the measurement is complete.

C-26. A special case for INX is created when Maximum Voltage (SRX VOLT) is set to zero. This is used to trigger an autozero cycle. The time required to complete the autozero cycle, including MAXT, will be returned. The SRX limit remains at zero, so it is necessary to perform a new SETUP after an autozero cycle. The result phase (FTH) after autozero is always zero, unless an error is encountered.

C-27. In addition to syntax errors, the following messages may be generated:

- a. No error: <sp>ddd<cr><lf>
- b. Instrument not SETUP: F07HFV0n (MOD): H.F. VOLTMETER NOT SETUP <cr><lf>
- c. Instrument not CLOSED: F07HFV0n (MOD): H.F. VOLTMETER NOT CONNECTED <cr><lf>

Note: d = ascii numeric digit (0 - 9)

C-28. RESULT FETCH.

C-29. The measurement value is requested by the command:

FTH VOLT <cr><lf>

C-30. The instrument will determine if a settled reading was possible within the settling time limit reported to the controller during the INX command. The measurement value is tested against the maximum and minimum limits established during the SETUP command. If no errors occur, the reading is loaded into the output buffer; otherwise, an error message is loaded.

C-31. Execution of the FTH command also returns the 92008 to CLOSED and not-INITIATED status. Any number of successive INX - FTH measurement cycles may be performed while still CLOSED.

C-32. In addition to syntax errors, the following messages may be generated:

- a. No error: <sp>0,ddddEsd<cr><lf>
- b. Instrument not SETUP: F07HFV0n (MOD): H,F, VOLTMETER NOT SETUP <cr><lf>
- c. Instrument not CLOSED: F07HFV0n (MOD): H,F, VOLTMETER NOT CONNECTED <cr><lf>
- d. Measurement not INITIATED: F07HFV0n (MOD): MEASUREMENT NOT INITIATED <cr><lf>
- e. Measurement did not settle: F05HFV0n (DEV): MEASUREMENT TIMEOUT <cr><lf>
- f. Measurement exceeded maximum limit: F00HFV0n (DEV): MEASURED VOLTAGE GREATER THAN MAXIMUM <cr><lf>
- g. Measurement less than minimum limit: F01HFV0n (DEV): MEASURED VOLTAGE LESS THAN MINIMUM <cr><lf>

Notes: s = exponent sign, +/-

C-33. DISCONNECT.

C-34. The 9200B may be logically disconnected from the test system by the command:

OPN :CHn<cr><lf>

C-35. The channel identification must agree with the currently active channel; otherwise an illegal channel error will be generated. The channel must have been SETUP prior to issuing this command.

C-36. After execution of the OPN command, it is necessary to send the CLS command prior to INX and FTH commands.

C-37. In addition to syntax errors, the following messages may be generated:

- a. No error: <sp><cr><lf>
- b. Improper channel command: F07HFV0n (DEV): ILLEGAL CHANNEL PROGRAMMED H,F, VOLTMETER <cr><lf>
- c. Instrument not SETUP: F07HFV0n (MOD): H,F, VOLTMETER NOT SETUP <cr><lf>

C-38. RESET.

C-39. The RESET command addresses a specific channel, clears any pending error messages and sets the 9200B to not-SETUP status. The syntax is:

RST ACS VOLT :CHn<cr><lf>

C-40. An illegal channel error message is generated if the channel addressed does not exist.

C-41. The IEEE-488 bus command DCL (Device Clear) will perform a RESET on the currently active channel.

C-42. In addition to syntax errors, the following messages may be generated:

- a. No error: <sp><cr><lf>
- b. Improper channel command: F07HFV0n (DEV): ILLEGAL CHANNEL PROGRAMMED H,F, VOLTMETER <cr><lf>

C-43. SELF TEST.

C-44. Two self-test commands are recognized by the 9200B, but the same internal test is done for both. The test is a check-sum verification of the 9200B program memory. The command syntax is:

CNF<cr><lf> or IST<cr><lf>

C-45. Each of these commands also does an implied RESET, returning the 9200B to not-SETUP status, and clearing any pending errors prior to self-test.

C-46. In addition to syntax errors, the following messages may be generated:

- a. No error: <sp><cr><lf>
- b. Checksum error, CNF command: F07HFV0n (DEV): CONFIDENCE TEST FAILURE <cr><lf>
- c. Checksum error, IST command: F07HFV0n (DEV): BIT TEST FAILURE RAM/ROM <cr><lf>

C-47. STATUS COMMAND.

C-48. Messages in the output buffer must be enabled prior to being sent to the controller. Except after an INX or FTH command, which implicitly enable the output buffer, the STA command must be sent to access the current message. When the STA command is received by the 9200B, the no-error message is loaded unless an error message is already present, and the buffer is enabled. A subsequent talk command on the IEEE-488 bus will cause the message to be sent to the controller.

C-49. Any error message in the output buffer prevents further loading of the buffer until the message is sent over the bus, or a RESET occurs.

C-50. The syntax for the STATUS command is:

STA<cr><lf>

C-51. If no error message exists in the output buffer, the following message is generated:

- a. No errors: <sp><cr><lf>

C-52. SOFTWARE CODES.

C-53. The display will indicate the week and year code of the software version installed in the instrument for approximately two seconds after the instrument is turned on.

Example: 0885

Indicates week 8 year 1985.

APPENDIX C  
OPTION 92008-06

C-54. MAINTENANCE.

C-55. To perform any of the maintenance procedures outlined in Section V of the 92008 Manual, set Interface Board Bit Switch 8 for native mode operation. This will allow IEEE-488 access to instrument calibration functions. Restore the MATE configuration after maintenance procedures are complete.

# WARRANTY

Boonton Electronics Corporation warrants its products to the original Purchaser to be free from defects in material and workmanship and to operate within applicable specifications for a period of one year from date of shipment, provided they are used under normal operating conditions. This warranty does not apply to active devices that have given normal service, to sealed assemblies which have been opened, or to any item which has been repaired or altered without our authorization.

We will repair or, at our option, replace at no charge any of our products which are found to be defective under the terms of this warranty. Except for such repair or replacement, we will not be liable for any incidental damages or for any consequential damages, as those terms are defined in Section 2-715 of the Uniform Commercial Code, in connection with products covered by this warranty.

**BOONTON**  
**ELECTRONICS CORPORATION**

25 EASTMANS ROAD  
PARSIPPANY, NJ 07054-0465 USA  
PHONE: (973) 386-9696  
FAX: (973) 386-9191