

Agilent 34401A Multimeter



COPYRIGHT AND DISCLAIMER NOTICE

Copyright – Agilent Technologies, Inc. Reproduced with the permission of Agilent Technologies Inc. Agilent Technologies, Inc. makes no warranty of any kind with regard to this material including, but not limited to, the implied warranties of merchantability and fitness for a particular purpose. Agilent Technologies, Inc. is not liable for errors contained herein or for incidental or consequential damages in connection with the furnishing, performance, or use of this material or data.

Copyright © 1991-2000
Hewlett-Packard Company
All Rights Reserved.

Printing History

Edition 1, November 1991
Edition 2, March 1992
Edition 3, June 1992
Edition 4, February 1996
Edition 5, March 2000

New editions are complete revisions of the manual. Update packages, which are issued between editions, may contain additional information and replacement pages which you merge into the manual. The dates on this page change only when a new edition is published.

Trademark Information

Windows, Windows 95, and Windows NT are registered trademarks of Microsoft Corp.

Certification

Hewlett-Packard (HP) certifies that this product met its published specifications at the time of shipment. HP further certifies that its calibration measurements are traceable to the United States National Institute of Standards and Technology (formerly National Bureau of Standards), to the extent allowed by that organization's calibration facility, and to the calibration facilities of other International Standards Organization members.

Warranty

This HP product is warranted against defects in materials and workmanship for a period of three years from date of shipment. Duration and conditions of warranty for this product may be superceded when the product is integrated into (becomes a part of) other HP products. During the warranty period, HP will, at its option, either repair or replace products which prove to be defective. The warranty period begins on the date of delivery or on the date of installation if installed by HP.

Warranty Service

For warranty service or repair, this product must be returned to a service facility designated by HP. For products returned to HP for warranty service, the Buyer shall prepay shipping charges to HP and HP shall pay shipping charges to return the product to the Buyer. However, the Buyer shall pay all shipping charges, duties, and taxes for products returned to HP from another country.

Limitation of Warranty

The foregoing warranty shall not apply to defects resulting from improper or inadequate maintenance by the Buyer, Buyer-supplied products or interfacing, unauthorized modification or misuse, operation outside of the environmental specifications for the product, or improper site preparation or maintenance.

The design and implementation of any circuit on this product is the sole responsibility of the Buyer. HP does not warrant the Buyer's circuitry or malfunctions of HP products that result from the Buyer's circuitry. In addition, HP does not warrant any damage that occurs as a result of the Buyer's circuit or any defects that result from Buyer-supplied products.

To the extent allowed by local law, HP makes no other warranty, expressed or implied, whether written or oral with respect to this product and specifically disclaims any implied warranty or condition of merchantability, fitness for a particular purpose or satisfactory quality.

For transactions in Australia and New Zealand: The warranty terms contained in this statement, except to the extent lawfully permitted, do not exclude, restrict, or modify and are in addition to the mandatory statutory rights applicable to the sale of this product.

Exclusive Remedies

To the extent allowed by local law, the remedies provided herein are the Buyer's sole and exclusive remedies. HP shall not be liable for any direct, indirect, special, incidental, or consequential damages (including lost profit or data), whether based on warranty, contract, tort, or any other legal theory.

Notice

The information contained in this document is subject to change without notice.

To the extent allowed by local law, HP makes no warranty of any kind with regard to this material, including, but not limited to, the implied warranties of merchantability and fitness for a particular purpose.

To the extent allowed by local law, HP shall not be liable for errors contained herein or for incidental or consequential damages in connection with the furnishing, performance, or use of this material. No part of this document may be photocopied, reproduced, or translated to another language without the prior written consent of HP.

Restricted Rights

The Software and Documentation have been developed entirely at private expense. They are delivered and licensed as "commercial computer software" as defined in DFARS 252.227-7013 (Oct 1988), DFARS 252.211-7015 (May 1991), or DFARS 252.227-7014 (Jun 1995), as a "commercial item" as defined in FAR 2.101(a), or as "restricted computer software" as defined in FAR 52.227-19 (Jun 1987) (or any equivalent agency regulation or contract clause), whichever is applicable. You have only those rights provided for such Software and Documentation by the applicable FAR or DFARS clause or the HP standard software agreement for the product involved.

Safety Information

Do not install substitute parts or perform any unauthorized modification to the product. Return the product to an HP Sales and Service Office for service and repair to ensure that safety features are maintained.

Safety Symbols

Warning

Calls attention to a procedure, practice, or condition, that could possibly cause bodily injury or death.

Caution

Calls attention to a procedure, practice, or condition that could possibly cause damage to equipment or permanent loss of data.



Earth ground symbol.



Chassis ground symbol.



Refer to the manual for specific Warning or Caution information to avoid personal injury or equipment damage.



Hazardous voltages may be present.

Warning

No operator serviceable parts inside. Refer servicing to service-trained personnel.

Warning

For continued protection against fire, replace the line fuse only with a fuse of the specified type and rating.

Power-On and Reset State

1

Specifications

2

Quick Start

3

Menu Tutorial

4

Calibration Procedures

5

Theory of Operation

6

Service

7

Replaceable Parts

8

Backdating

9

Schematics

The parameters marked with a bullet (•) are stored in *non-volatile* memory. The factory settings are shown.

Measurement Configuration AC Filter Autozero • Continuity Threshold Function Input Resistance Integration Time Range Resolution	Power-On/Reset State 20 Hz (medium filter) On • 10 Ω DC volts 10 M Ω (<i>fixed for all dcV ranges</i>) 10 PLCs Autorange 5½ digits, slow mode
Math Operations Math State, Function Math Registers • dBm Reference Resistance	Power-On/Reset State Off, Null All registers are cleared • 600 Ω
Triggering Operations Reading Hold Threshold Samples Per Trigger Trigger Delay Trigger Source	Power-On/Reset State 0.10% of range 1 sample Automatic Delay Auto Trigger
System-Related Operations • Beeper Mode • Comma Separators Display Mode Reading Memory	Power-On/Reset State • On • On On Off (cleared)
Input/Output Configuration • Baud Rate • GPIB Address • Interface • Language • Parity	Power-On/Reset State • 9600 baud • 22 • GPIB (IEEE-488) • SCPI • Even (7 data bits)
Calibration • Calibration State	Power-On/Reset State • Secured

Contents

The Front Panel at a Glance	2
The Front-Panel Menu at a Glance	3
Display Annunciators	4
The Rear Panel at a Glance	5
In This Book	6
Chapter 1 – Specifications	11
Chapter 2 – Quick Start	27
Chapter 3 – Menu Tutorial	47
Chapter 4 – Calibration Procedures	59
Chapter 5 – Theory of Operation	91
Chapter 6 – Service	109
Chapter 7 – Replaceable Parts	125
Chapter 8 – Backdating	137
Chapter 9 – Schematics	143

Note: *Unless otherwise indicated, this manual applies to all serial numbers.*

The Agilent Technologies 34401A is a 6½-digit, high-performance digital multimeter. Its combination of bench-top and system features makes this multimeter a versatile solution for your measurement needs now and in the future.

Convenient Bench-Top Features

- Highly visible vacuum-fluorescent display
- Built-in math operations
- Continuity and diode test functions
- Hands-free, Reading Hold feature
- Portable, ruggedized case with non-skid feet

Flexible System Features

- GPIB (IEEE-488) interface and RS-232 interface
- Standard programming languages: SCPI, Agilent 3478A, and Fluke 8840
- Reading rates up to 1000 readings per second
- Storage for up to 512 readings
- Limit testing with pass/fail signals
- Optional *34812A BenchLink Meter Software* for Microsoft® Windows™

Warning

The procedures in this manual are intended for use by qualified, service-trained personnel only.

Agilent 34401A Multimeter

The Front Panel at a Glance

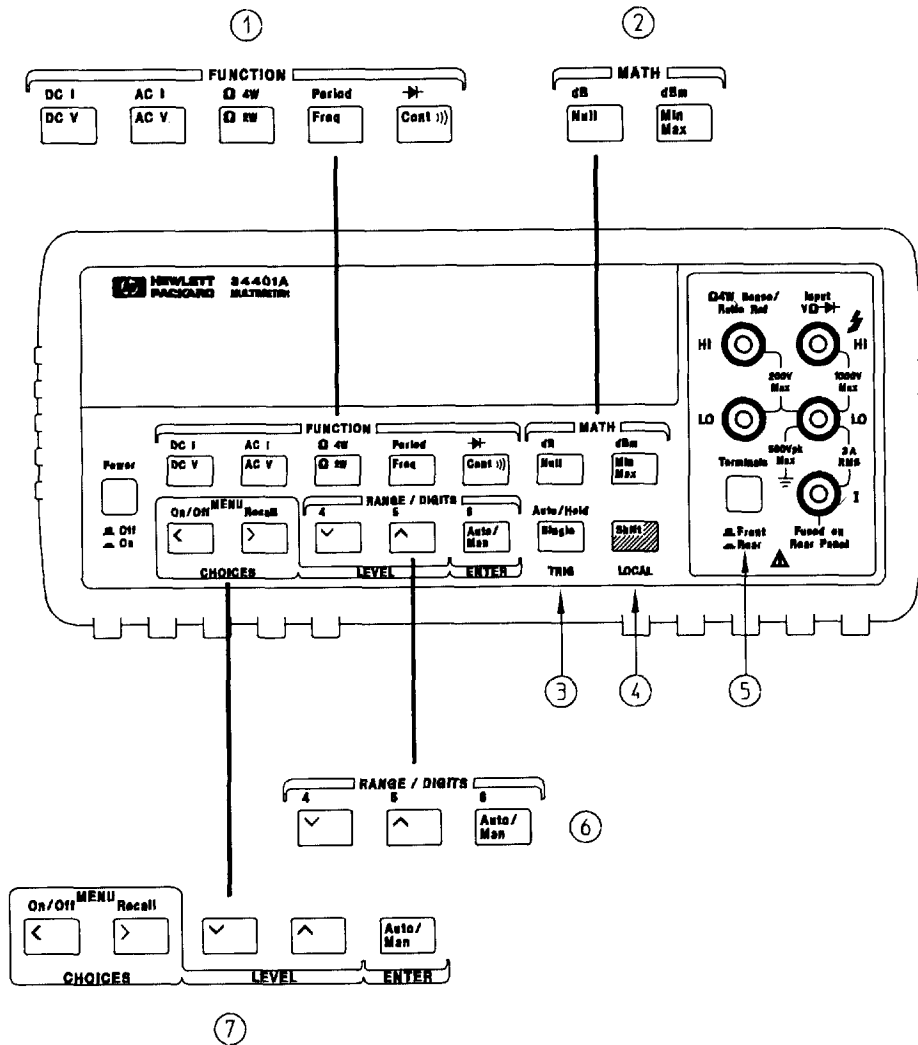

- | | |
|---|---|
| 1 Measurement Function keys | 5 Front / Rear Input Terminal Switch |
| 2 Math Operation keys | 6 Range / Number of Digits Displayed keys |
| 3 Single Trigger / Autotrigger / Reading Hold key | 7 Menu Operation keys |
| 4 Shift / Local key | |

The Front-Panel Menu at a Glance

The menu is organized in a top-down tree structure with three levels.

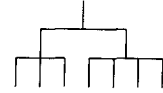

To turn on menu press:



To move left or right



To move up or down

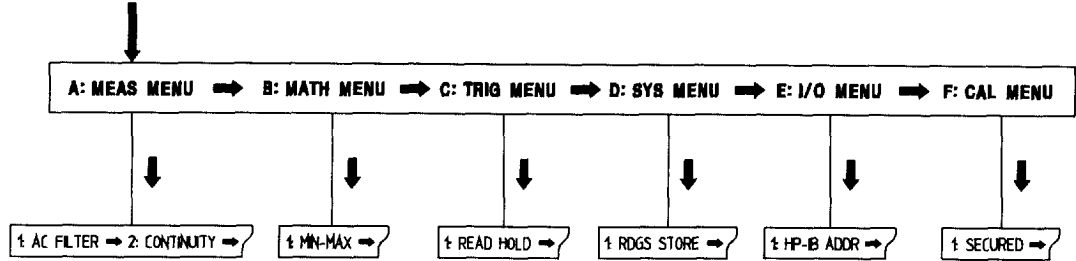

To enter command press:



A: MEASUREMENT MENU

1: AC FILTER → 2: CONTINUITY → 3: INPUT R → 4: RATIO FUNC → 5: RESOLUTION

B: MATH MENU

1: MIN-MAX → 2: NULL VALUE → 3: dB REL → 4: dBm REF R → 5: LIMIT TEST → 6: HIGH LIMIT → 7: LOW LIMIT

C: TRIGGER MENU

1: READ HOLD → 2: TRIG DELAY → 3: N SAMPLES

D: SYSTEM MENU

1: RDGS STORE → 2: SAVED RDGS → 3: ERROR → 4: TEST → 5: DISPLAY → 6: BEEP → 7: COMMA → 8: REVISION

E: Input / Output MENU

1: HP-IB ADDR → 2: INTERFACE → 3: BAUD RATE → 4: PARITY → 5: LANGUAGE

F: CALIBRATION MENU*

1: SECURED → [1: UNSECURED] → [2: CALIBRATE] → 3: CAL COUNT → 4: MESSAGE

* The commands enclosed in square brackets ([]) are "hidden" unless the multimeter is UNSECURED for calibration.

Display Annunciators

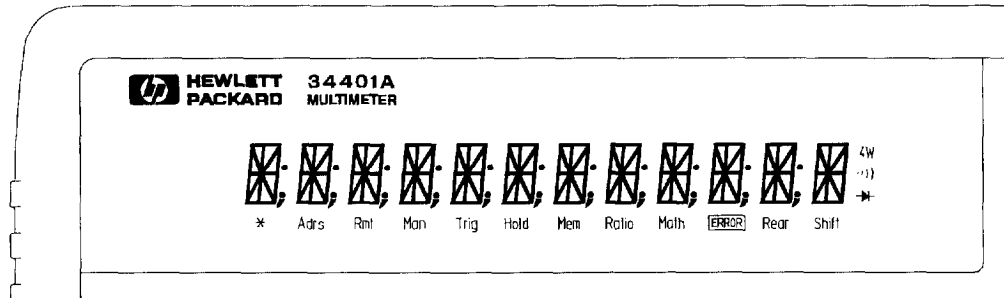

*	Turns on during a measurement.
Adrs	Multimeter is addressed to listen or talk over the HP-IB interface.
Rmt	Multimeter is in remote mode (remote interface).
Man	Multimeter is using manual ranging (autorange is disabled).
Trig	Multimeter is waiting for a single trigger or external trigger.
Hold	Reading Hold is enabled.
Mem	Turns on when reading memory is enabled.
Ratio	Multimeter is in dcv:dcv ratio function.
Math	A math operation is enabled (null, min-max, dB, dBm, or limit test).
ERROR	Hardware or remote interface command errors are detected.
Rear	Rear input terminals are selected.
Shift	"Shift" key has been pressed. <i>Press "Shift" again to turn off.</i>
4W	Multimeter is in 4-wire ohms function.
·)	Multimeter is in continuity test function.
▶	Multimeter is in diode test function.

To review the display annunciators, hold down the key as you turn on the multimeter.

The Rear Panel at a Glance

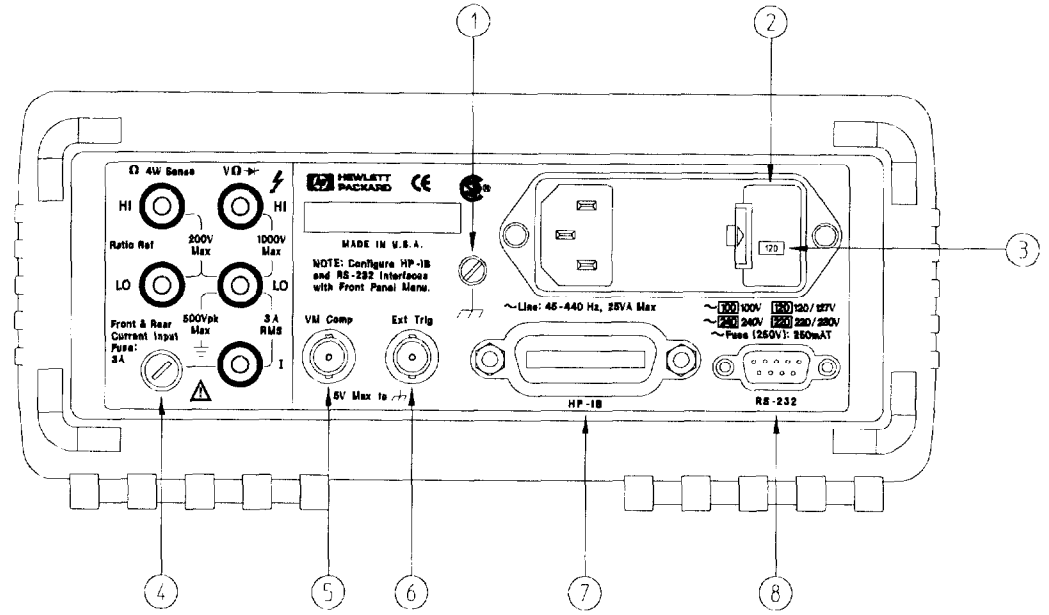

- | | |
|-------------------------------------|--|
| 1 Chassis Ground | 5 Voltmeter Complete Output Terminal |
| 2 Power-Line Fuse-Holder Assembly | 6 External Trigger Input Terminal |
| 3 Power-Line Voltage Setting | 7 HP-IB (IEEE-488) Interface connector |
| 4 Front and Rear Current Input Fuse | 8 RS-232 interface connector |

Use the front-panel Input / Output Menu to:

- Select the HP-IB or RS-232 interface (see chapter 4 in the "User's Guide").
- Set the HP-IB bus address (see chapter 4 in the "User's Guide").
- Set the RS-232 baud rate and parity (see chapter 4 in the "User's Guide").

In This Book

Specifications Chapter 1 lists the multimeter's specifications and describes how to interpret these specifications.

Quick Start Chapter 2 prepares the multimeter for use and helps you get familiar with a few of its front-panel features.

Menu Tutorial Chapter 3 introduces you to the front-panel menu and steps you through several simple menu examples.

Calibration Procedures Chapter 4 provides a detailed description of the multimeter's calibrations and adjustments.

Theory of Operation Chapter 5 describes each functional block in the multimeter.

Service Chapter 6 provides guidelines for returning your multimeter to Hewlett-Packard for servicing, or for servicing it yourself.

Replaceable Parts Chapter 7 contains a detailed parts list of the multimeter.

Backdating Chapter 8 describes the procedures involved with back issues of this manual.

Schematics Chapter 9 provides the multimeter's schematics.

If you have questions relating to the operation of the HP 34401A, call 1-800-452-4844 in the United States, or contact your nearest Hewlett-Packard Sales Office.

If your HP 34401A fails within three years of purchase, HP will repair or replace it free of charge. Call 1-800-258-5165 ("Express Exchange") in the United States, or contact your nearest Hewlett-Packard Sales Office.

Contents

Chapter 1 Specifications

DC Characteristics	12
AC Characteristics	14
Frequency and Period Characteristics	16
General Information	18
Product Dimensions	19
To Calculate Total Measurement Error	20
Interpreting Multimeter Specifications	22
Configuring for Highest Accuracy Measurements	25

Chapter 2 Quick Start

To Prepare the Multimeter for Use	29
If the Multimeter Does Not Turn On	30
To Adjust the Carrying Handle	32
To Measure Voltage	33
To Measure Resistance	33
To Measure Current	34
To Measure Frequency (or Period)	34
To Test Continuity	35
To Check Diodes	35
To Select a Range	36
To Set the Resolution	37
To Make Null (Relative) Measurements	38
To Store Minimum and Maximum Readings	39
To Make dB Measurements	40
To Make dBm Measurements	41
To Trigger the Multimeter	42
To Make dcv:dcv Ratio Measurements	43
Front-Panel Display Formats	44
To Rack Mount the Multimeter	45

Chapter 3 Menu Tutorial

Front-Panel Menu Reference	49
A Front-Panel Menu Tutorial	51
Menu Examples	53

Contents**Chapter 4 Calibration Procedures**

Hewlett-Packard Calibration Services	61
Calibration Interval	61
Time Required for Calibration	61
Automating Calibration Procedures	62
Recommended Test Equipment	63
Test Considerations	64
Performance Verification Tests	65
Zero Offset Verification	67
Gain Verification	69
Optional AC Performance Verification Tests	72
Calibration Security Code	73
Calibration Count	75
Calibration Message	75
Calibration Procedures	76
Aborting a Calibration in Progress	76
Zero Adjustment	77
Gain Adjustment	79
Optional Gain Calibration Procedures	82
Understanding the AC Signal Filter	85
Understanding Resolution	86
Error Messages	89

Chapter 5 Theory of Operation

Block Diagram	93
Front/Rear Selection	94
Function Switching	95
DC Amplifier	96
Ohms Current Source	98
AC Circuit	99
A-to-D Converter	101
Floating Logic	103
Earth-Referenced Logic	105
Power Supplies	106
Front Panel	107

Chapter 6 Service

- Operating Checklist 111
- Types of Service Available 112
- Repackaging for Shipment 113
- Electrostatic Discharge (ESD) Precautions 114
- Surface Mount Repair 114
- To Replace the Power-Line Fuse 114
- To Replace The Current Input Fuses 115
- To Connect Pass/Fail Output Signals 115
- Troubleshooting Hints 117
- Self-Test Procedures 120

Chapter 7 Replaceable Parts

- To Order Replaceable Parts 126
- Backdating and Part Changes 126
- Replaceable Parts: 34401-66501 (Main Assembly) 127
- Replaceable Parts: 34401-66512 (Display Assembly) 133
- Replaceable Parts: HP 34401A Mainframe 134
- Manufacturer's List 135

Chapter 8 Backdating 137

Chapter 9 Schematics

- Mechanical Disassembly 9-3
- Component Locator Diagram – Main Board (34401-66501) 9-5
- Component Locator Diagram – Front Panel (34401-66512) 9-6
- HP 34401A Block Diagram 9-7
- Front/Rear Selection Schematic 9-8
- Function Switching Schematic 9-9
- DC Amplifier and Ohms Schematic 9-10
- AC Circuit Schematic 9-11
- A/D Converter Schematic 9-12
- Floating Logic Schematic 9-13
- Earth-Referenced Logic Schematic 9-14
- Power Supplies Schematic 9-15
- Front-Panel Display Schematic 9-16

Contents

Specifications

Chapter 1 Specifications
DC Characteristics

■ **DC Characteristics**

Accuracy Specifications ± (% of reading + % of range) [1]

Function	Range [3]	Test Current or Burden Voltage	24 Hour [2] 23°C ± 1°C	90 Day 23°C ± 5°C	1 Year 23°C ± 5°C	Temperature Coefficient /°C 0°C – 18°C 28°C – 55°C
DC Voltage	100.0000 mV		0.0030 + 0.0030	0.0040 + 0.0035	0.0050 + 0.0035	0.0005 + 0.0005
	1.000000 V		0.0020 + 0.0006	0.0030 + 0.0007	0.0040 + 0.0007	0.0005 + 0.0001
	10.00000 V		0.0015 + 0.0004	0.0020 + 0.0005	0.0035 + 0.0005	0.0005 + 0.0001
	100.0000 V		0.0020 + 0.0006	0.0035 + 0.0006	0.0045 + 0.0006	0.0005 + 0.0001
	1000.000 V		0.0020 + 0.0006	0.0035 + 0.0010	0.0045 + 0.0010	0.0005 + 0.0001
Resistance [4]	100.0000 Ω	1 mA	0.0030 + 0.0030	0.008 + 0.004	0.010 + 0.004	0.0006 + 0.0005
	1.000000 kΩ	1 mA	0.0020 + 0.0005	0.008 + 0.001	0.010 + 0.001	0.0006 + 0.0001
	10.00000 kΩ	100 μA	0.0020 + 0.0005	0.008 + 0.001	0.010 + 0.001	0.0006 + 0.0001
	100.0000 kΩ	10 μA	0.0020 + 0.0005	0.008 + 0.001	0.010 + 0.001	0.0006 + 0.0001
	1.000000 MΩ	5 μA	0.002 + 0.001	0.008 + 0.001	0.010 + 0.001	0.0010 + 0.0002
	10.00000 MΩ	500 nA	0.015 + 0.001	0.020 + 0.001	0.040 + 0.001	0.0030 + 0.0004
	100.0000 MΩ	500 nA // 10 MΩ	0.300 + 0.010	0.800 + 0.010	0.800 + 0.010	0.1500 + 0.0002
DC Current	10.00000 mA	< 0.1 V	0.005 + 0.010	0.030 + 0.020	0.050 + 0.020	0.002 + 0.0020
	100.0000 mA	< 0.6 V	0.01 + 0.004	0.030 + 0.005	0.050 + 0.005	0.002 + 0.0005
	1.000000 A	< 1 V	0.05 + 0.006	0.080 + 0.010	0.100 + 0.010	0.005 + 0.0010
	3.000000 A	< 2 V	0.10 + 0.020	0.120 + 0.020	0.120 + 0.020	0.005 + 0.0020
Continuity	1000.0 Ω	1 mA	0.002 + 0.010	0.008 + 0.020	0.010 + 0.020	0.001 + 0.002
Diode Test	1.0000 V	1 mA	0.002 + 0.010	0.008 + 0.020	0.010 + 0.020	0.001 + 0.002
DC:DC Ratio	100 mV to 1000 V		(Input Accuracy) + (Reference Accuracy)			
			<i>Input Accuracy</i> = accuracy specification for the HI-LO input signal. <i>Reference Accuracy</i> = accuracy specification for the HI-LO reference input signal.			

Transfer Accuracy (typical)

$$\frac{\text{(24 hour \% of range error)}}{2}$$

Conditions:

- Within 10 minutes and ± 0.5°C.
- Within ±10% of initial value.
- Following a 2-hour warm-up.
- Fixed range between 10% and 100% of full scale.
- Using 6½ digit slow resolution (100 PLC).
- Measurements are made using accepted metrology practices.

Measuring Characteristics

DC Voltage

Measurement Method:	Continuously integrating, multi-slope III A/D converter.
A/D Linearity:	0.0002% of reading + 0.0001% of range
Input Resistance:	
0.1 V, 1 V, 10 V ranges	Selectable 10 M Ω or >10 G Ω [11]
100 V, 1000 V ranges	10 M Ω \pm 1%
Input Bias Current:	< 30 pA at 25°C
Input Terminals:	Copper alloy
Input Protection:	1000 V on all ranges

Resistance

Measurement Method:	Selectable 4-wire or 2-wire ohms. Current source referenced to LO input.
Max. Lead Resistance: (4-wire ohms)	10% of range per lead for 100 Ω , 1 k Ω ranges. 1 k Ω per lead on all other ranges.
Input Protection:	1000 V on all ranges

DC Current

Shunt Resistor:	0.1 Ω for 1A, 3A. 5 Ω for 10 mA, 100 mA
Input Protection:	Externally accessible 3A, 250 V fuse Internal 7A, 250 V fuse

Continuity / Diode Test

Response Time:	300 samples/sec with audible tone
Continuity Threshold:	Adjustable from 1 Ω to 1000 Ω

DC:DC Ratio

Measurement Method:	Input HI-LO / Reference HI-LO
Input HI-LO	100 mV to 1000 V ranges
Reference HI-Input LO	100 mV to 10 V ranges (autoranged)
Input to Reference	Reference LO to Input LO voltage < 2 V Reference HI to Input LO voltage < 12V

Measurement Noise Rejection

60 Hz (50 Hz) [5]

DC CMRR	140 dB
---------	--------

Integration Time

100 PLC / 1.67s (2s)
10 PLC / 167 ms (200 ms)
1 PLC / 16.7 ms (20 ms)
0.2 PLC / 3 ms (3 ms)
0.02 PLC / 400 μ s (400 μ s)

Normal Mode Rejection [6]

60 dB [7]
60 dB [7]
60 dB [7]
0 dB
0 dB

Operating Characteristics [8]

Function	Digits	Readings/s	Additional Noise Error
DCV, DCI, and Resistance	6½	0.6 (0.5)	0% of range
	6½	6 (5)	0% of range
	5½	60 (50)	0.001% of range
	5½	300	0.001% of range [10]
	4½	1000	0.01% of range [10]

System Speeds [9]

Function Change	26/sec
Range Change	50/sec
Autorange Time	<30 ms
ASCII readings to RS-232	55/sec
ASCII readings to HP-IB	1000/sec
Max. Internal Trigger Rate	1000/sec
Max. External Trigger Rate to Memory	1000/sec
Max. External Trigger Rate to HP-IB	900/sec

Autozero OFF Operation

Following instrument warm-up at calibration temperature \pm 1°C and <10 minutes, add 0.0002% range additional error + 5 μ V.

Settling Considerations

Reading settling times are affected by source impedance, cable dielectric characteristics, and input signal changes.

Measurement Considerations

HP recommends the use of Teflon® or other high-impedance, low-dielectric absorption wire insulation for these measurements.

- [1] Specifications are for 1-hour warm-up at 6½ digits.
- [2] Relative to calibration standards.
- [3] 20% overrange on all ranges, except 1000 Vdc, 3 A range.
- [4] Specifications are for 4-wire ohms function, or 2-wire ohms using Math Null. Without Math Null, add 0.2 Ω additional error in 2-wire ohms function.
- [5] For 1 k Ω unbalance in LO lead.
- [6] For power-line frequency \pm 0.1%.
- [7] For power-line frequency \pm 1%, subtract 20 dB. For \pm 3%, subtract 30 dB.
- [8] Readings speeds for 60 Hz and (50 Hz) operation, Autozero Off.
- [9] Speeds are for 4½ digits, Delay 0, Autozero OFF, and Display OFF. Includes measurement and data transfer over HP-IB.
- [10] Add 20 μ V for dc volts, 4 μ A for dc current, or 20 m Ω for resistance.
- [11] For these ranges, inputs beyond \pm 17V are clamped through 100 k Ω (typical).

Teflon is a registered trademark of E.I. duPont deNemours and Co.

■ AC Characteristics

Accuracy Specifications ± (% of reading + % of range) [1]

Function	Range [3]	Frequency	24 Hour [2] 23°C ± 1°C	90 Day 23°C ± 5°C	1 Year 23°C ± 5°C	Temperature Coefficient/°C 0°C – 18°C 28°C – 55°C
True RMS AC Voltage [4]	100.0000 mV	3 Hz – 5 Hz	1.00 + 0.03	1.00 + 0.04	1.00 + 0.04	0.100 + 0.004
		5 Hz – 10 Hz	0.35 + 0.03	0.35 + 0.04	0.35 + 0.04	0.035 + 0.004
		10 Hz – 20 kHz	0.04 + 0.03	0.05 + 0.04	0.06 + 0.04	0.005 + 0.004
		20 kHz – 50 kHz	0.10 + 0.05	0.11 + 0.05	0.12 + 0.05	0.011 + 0.005
		50 kHz – 100 kHz	0.55 + 0.08	0.60 + 0.08	0.60 + 0.08	0.060 + 0.008
		100 kHz – 300 kHz [6]	4.00 + 0.50	4.00 + 0.50	4.00 + 0.50	0.20 + 0.02
	1.000000 V to 750.000 V	3 Hz – 5 Hz	1.00 + 0.02	1.00 + 0.03	1.00 + 0.03	0.100 + 0.003
		5 Hz – 10 Hz	0.35 + 0.02	0.35 + 0.03	0.35 + 0.03	0.035 + 0.003
		10 Hz – 20 kHz	0.04 + 0.02	0.05 + 0.03	0.06 + 0.03	0.005 + 0.003
		20 kHz – 50 kHz	0.10 + 0.04	0.11 + 0.05	0.12 + 0.05	0.011 + 0.005
50 kHz – 100 kHz [5] 100 kHz – 300 kHz [6]		0.55 + 0.08 4.00 + 0.50	0.60 + 0.08 4.00 + 0.50	0.60 + 0.08 4.00 + 0.50	0.060 + 0.008 0.20 + 0.02	
True RMS AC Current [4]	1.000000 A	3 Hz – 5 Hz	1.00 + 0.04	1.00 + 0.04	1.00 + 0.04	0.100 + 0.006
		5 Hz – 10 Hz	0.30 + 0.04	0.30 + 0.04	0.30 + 0.04	0.035 + 0.006
		10 Hz – 5 kHz	0.10 + 0.04	0.10 + 0.04	0.10 + 0.04	0.015 + 0.006
	3.00000 A	3 Hz – 5 Hz	1.10 + 0.06	1.10 + 0.06	1.10 + 0.06	0.100 + 0.006
		5 Hz – 10 Hz	0.35 + 0.06	0.35 + 0.06	0.35 + 0.06	0.035 + 0.006
		10 Hz – 5 kHz	0.15 + 0.06	0.15 + 0.06	0.15 + 0.06	0.015 + 0.006

Additional Low Frequency Errors (% of reading)

Frequency	AC Filter		
	Slow	Medium	Fast
10 Hz – 20 Hz	0	0.74	—
20 Hz – 40 Hz	0	0.22	—
40 Hz – 100 Hz	0	0.06	0.73
100 Hz – 200 Hz	0	0.01	0.22
200 Hz – 1 kHz	0	0	0.18
> 1 kHz	0	0	0

Additional Crest Factor Errors (non-sinewave) [7]

Crest Factor	Error (% of reading)
1 – 2	0.05%
2 – 3	0.15%
3 – 4	0.30%
4 – 5	0.40%

Sinewave Transfer Accuracy (typical)

Frequency	Error (% of range)
10 Hz – 50 kHz	0.002%
50 kHz – 300 kHz	0.005%

Conditions:

- Sinewave input.
- Within 10 minutes and ± 0.5°C.
- Within ±10% of initial voltage and ±1% of initial frequency.
- Following a 2-hour warm-up.
- Fixed range between 10% and 100% of full scale (and <120 V).
- Using 6½ digit resolution.
- Measurements are made using accepted metrology practices.

Measuring Characteristics

Measurement Noise Rejection [8]

AC CMRR 70 dB

True RMS AC Voltage

Measurement Method: AC-coupled True RMS – measures the ac component of input with up to 400 Vdc of bias on any range.

Crest Factor: Maximum 5:1 at full scale

AC Filter Bandwidth:

Slow 3 Hz – 300 kHz

Medium 20 Hz – 300 kHz

Fast 200 Hz – 300 kHz

Input Impedance: 1 M Ω \pm 2%, in parallel with 100 pF

Input Protection: 750 V rms all ranges

True RMS AC Current

Measurement Method: Direct coupled to the fuse and shunt. AC-coupled True RMS measurement (measures the ac component only).

Shunt Resistor: 0.1 Ω for 1 A and 3 A ranges

Burden Voltage: 1 A range: < 1 V rms

3 A range: < 2 V rms

Input Protection: Externally accessible 3A, 250 V fuse
Internal 7A, 250 V fuse

Settling Considerations

Applying >300 V rms (or >1 A rms) will cause self-heating in signal-conditioning components. These errors are included in the instrument specifications. Internal temperature changes due to self-heating may cause additional error on lower ac voltage ranges. The additional error will be less than 0.02% of reading and will generally dissipate within a few minutes.

Operating Characteristics [9]

Function	Digits	Reading/s	AC Filter
ACV, ACI	6½	7 sec/reading	Slow
	6½	1	Medium
	6½	1.6 [10]	Fast
	6½	10	Fast
	6½	50 [11]	Fast

System Speeds [11], [12]

Function or Range Change	5/sec
Autorange Time	<0.8 sec
ASCII readings to RS-232	50/sec
ASCII readings to HP-IB	50/sec
Max. Internal Trigger Rate	50/sec
Max. External Trigger Rate to Memory	50/sec
Max. External Trigger Rate to HP-IB/RS-232	50/sec

- [1] Specifications are for 1-hour warm-up at 6½ digits, Slow ac filter, sinewave input.
- [2] Relative to calibration standards.
- [3] 20% overrange on all ranges, except 750 Vac, 3 A range.
- [4] Specifications are for sinewave input >5% of range. For inputs from 1% to 5% of range and <50 kHz, add 0.1% of range additional error. For 50 kHz to 100 kHz, add 0.13% of range.
- [5] 750 Vac range limited to 100 kHz or 8x10⁷ Volt-Hz.
- [6] Typically 30% of reading error at 1 MHz.
- [7] For frequencies below 100 Hz, slow AC filter specified for sinewave input only.
- [8] For 1 k Ω unbalance in LO lead.
- [9] Maximum reading rates for 0.01% of ac step additional error. Additional settling delay required when input dc level varies.
- [10] For External Trigger or remote operation using default settling delay (Delay Auto).
- [11] Maximum useful limit with default settling delays defeated.
- [12] Speeds are for 4½ digits, Delay 0, Display OFF, and Fast AC filter.

■ Frequency and Period Characteristics

Accuracy Specifications ± (% of reading) [1]

Function	Range [3]	Frequency	24 Hour [2] 23°C ± 1°C	90 Day 23°C ± 5°C	1 Year 23°C ± 5°C	Temperature Coefficient/°C 0°C – 18°C 28°C – 55°C
Frequency, Period [4]	100 mV	3 Hz – 5 Hz	0.10	0.10	0.10	0.005
	to	5 Hz – 10 Hz	0.05	0.05	0.05	0.005
	750 V	10 Hz – 40 Hz	0.03	0.03	0.03	0.001
		40 Hz – 300 kHz	0.006	0.01	0.01	0.001

Additional Low-Frequency Errors (% of reading) [4]

Frequency	Resolution		
	6½	5½	4½
3 Hz – 5 Hz	0	0.12	0.12
5 Hz – 10 Hz	0	0.17	0.17
10 Hz – 40 Hz	0	0.2	0.2
40 Hz – 100 Hz	0	0.06	0.21
100 Hz – 300 Hz	0	0.03	0.21
300 Hz – 1 kHz	0	0.01	0.07
> 1 kHz	0	0	0.02

Transfer Accuracy (typical)
0.0005% of reading

Conditions:

- Within 10 minutes and ± 0.5°C.
- Within ±10% of initial value.
- Following a 2-hour warm-up.
- For inputs > 1 kHz and > 100 mV.
- Using 6½ digit slow resolution (1 second gate time).
- Measurements are made using accepted metrology practices.

Measuring Characteristics

Frequency and Period

Measurement Method: Reciprocal-counting technique.
 AC-coupled input using the ac voltage measurement function.
 Voltage Ranges: 100 mV rms full scale to 750 V rms.
 Gate Time: Auto or manual ranging.
 10 ms, 100 ms, or 1 sec

Settling Considerations

Errors will occur when attempting to measure the frequency or period of an input following a dc offset voltage change. The input blocking RC time constant must be allowed to fully settle (up to 1 sec) before the most accurate measurements are possible.

Measurement Considerations

All frequency counters are susceptible to error when measuring low-voltage, low-frequency signals. Shielding inputs from external noise pickup is critical for minimizing measurement errors.

Operating Characteristics [5]

Function	Digits	Reading/s
Frequency,	6½	1
Period	5½	9.8
	4½	80

System Speeds [5]

Configuration Rates	14/sec
Autorange Time	<0.6 sec
ASCII readings to RS-232	55/sec
ASCII readings to HP-IB	80/sec
Max. Internal Trigger Rate	80/sec
Max. External Trigger Rate to Memory	80/sec
Max. External Trigger Rate to HP-IB/RS-232	80/sec

- [1] Specifications are for 1-hour warm-up at 6½ digits.
- [2] Relative to calibration standards.
- [3] 20% overrange on all ranges, except 750 Vac range.
- [4] Input > 100 mV.
 For 10 mV input, multiply % of reading error x10.
- [5] Speeds are for 4½ digits, Delay 0, Display OFF, and Fast AC filter.

■ General Information

General Specifications

Power Supply:	100 V / 120 V / 220 V / 240 V \pm 10%.
Power Line Frequency:	45 Hz to 66 Hz and 360 Hz to 440 Hz. Automatically sensed at power-on.
Power Consumption:	25 VA peak (10 W average)
Operating Environment:	Full accuracy for 0°C to 55°C Full accuracy to 80% R.H. at 30°C
Storage Environment:	-40°C to 70°C
Rack Dimensions (HxWxD):	88.5 mm x 212.6 mm x 348.3 mm
Weight:	3.6 kg (8 lbs)
Safety:	Designed to CSA 231, UL 1244, IEC 1010-1 (1990)
EMI:	CISPR 11, IEC 801, MIL-461C (data on file)
Vibration and Shock:	MIL-T-28800E Type III, Class 5 (data on file)
Warranty:	3 years standard

Accessories Included

Test Lead Kit with probes, alligator, and grabber attachments.
User's Guide, Service Guide, test report, and power cord.

Triggering and Memory

Reading HOLD Sensitivity:	0.01%, 0.1%, 1%, or 10% of reading
Samples per Trigger:	1 to 50,000
Trigger Delay:	0 to 3600 sec (10 μ s step size)
External Trigger Delay:	< 1 ms
External Trigger Jitter:	< 500 μ s
Memory:	512 readings

Math Functions

Null, Min/Max/Average, dB, dBm, Limit Test (with TTL output).
dBm reference resistances: 50, 75, 93, 110, 124, 125, 135, 150,
250, 300, 500, **600**, 800, 900, 1000, 1200, or 8000 ohms.

Standard Programming Languages

SCPI (*Standard Commands for Programmable Instruments*)
HP 3478A Language Emulation
Fluke 8840A, Fluke 8842A Language Emulation

Remote Interface

HP-IB (IEEE-488.1, IEEE-488.2) and RS-232C

■ Product Dimensions

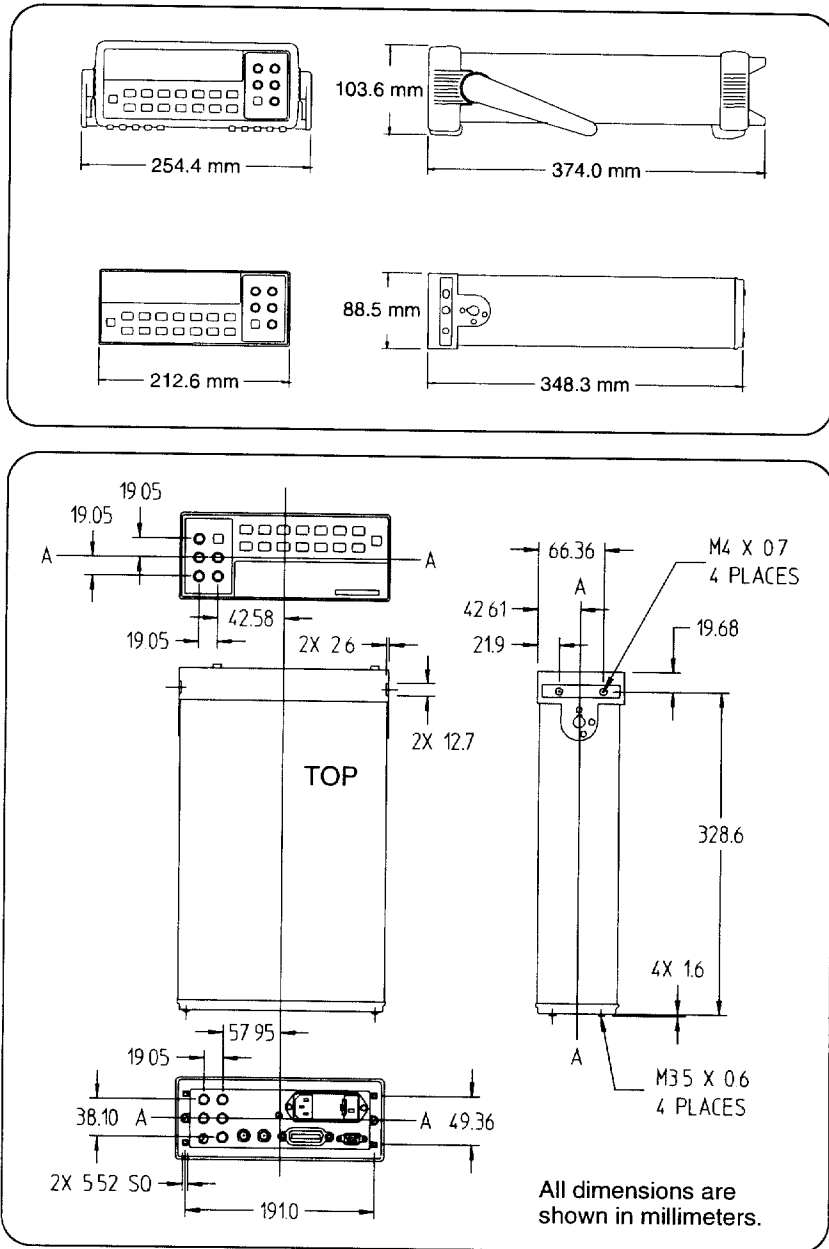

To Calculate Total Measurement Error

Each specification includes correction factors which account for errors present due to operational limitations of the multimeter. This section explains these errors and shows how to apply them to your measurements. Refer to “Interpreting Multimeter Specifications,” starting on page 22, to get a better understanding of the terminology used and to help you interpret the multimeter’s specifications.

The multimeter’s accuracy specifications are expressed in the form: (*% of reading + % of range*). In addition to the reading error and range error, you may need to add additional errors for certain operating conditions. Check the list below to make sure you include *all* measurement errors for a given function. Also, make sure you apply the conditions as described in the footnotes on the specification pages.

- If you are operating the multimeter outside the $23^{\circ}\text{C} \pm 5^{\circ}\text{C}$ temperature range specified, apply an additional *temperature coefficient error*.
- For dc voltage, dc current, and resistance measurements, you may need to apply an additional *reading speed error* or *autozero OFF error*.
- For ac voltage and ac current measurements, you may need to apply an additional *low frequency error* or *crest factor error*.

Understanding the “% of reading” Error The *reading error* compensates for inaccuracies that result from the function and range you select, as well as the input signal level. The reading error varies according to the input level on the selected range. This error is expressed in percent of reading. The following table shows the reading error applied to the multimeter’s 24-hour dc voltage specification.

Range	Input Level	Reading Error (% of reading)	Reading Error Voltage
10 Vdc	10 Vdc	0.0015	$\leq 150 \mu\text{V}$
10 Vdc	1 Vdc	0.0015	$\leq 15 \mu\text{V}$
10 Vdc	0.1 Vdc	0.0015	$\leq 1.5 \mu\text{V}$

Understanding the “% of range” Error The *range error* compensates for inaccuracies that result from the function and range you select. The range error contributes a constant error, expressed as a percent of range, *independent* of the input signal level. The following table shows the range error applied to the multimeter’s 24-hour dc voltage specification.

Range	Input Level	Range Error (% of range)	Range Error Voltage
10 Vdc	10 Vdc	0.0004	≤ 40 μV
10 Vdc	1 Vdc	0.0004	≤ 40 μV
10 Vdc	0.1 Vdc	0.0004	≤ 40 μV

Total Measurement Error To compute the total measurement error, add the reading error and range error. You can then convert the total measurement error to a “percent of input” error or a “ppm (part-per-million) of input” error as shown below.

$$\% \text{ of input error} = \frac{\text{Total Measurement Error}}{\text{Input Signal Level}} \times 100$$

$$\text{ppm of input error} = \frac{\text{Total Measurement Error}}{\text{Input Signal Level}} \times 1,000,000$$

Error Example

Assume that a 5 Vdc signal is input to the multimeter on the 10 Vdc range. Compute the total measurement error using the 90-day accuracy specifications: ±(0.0020% of reading + 0.0005% of range).

$$\begin{aligned} \text{Reading Error} &= 0.0020\% \times 5 \text{ Vdc} &&= 100 \mu\text{V} \\ \text{Range Error} &= 0.0005\% \times 10 \text{ Vdc} &&= 50 \mu\text{V} \\ \text{Total Error} &= 100 \mu\text{V} + 50 \mu\text{V} &&= \pm 150 \mu\text{V} \\ &&&= \pm 0.0030\% \text{ of } 5 \text{ Vdc} \\ &&&= \pm 30 \text{ ppm of } 5 \text{ Vdc} \end{aligned}$$

Interpreting Multimeter Specifications

This section is provided to give you a better understanding of the terminology used and will help you interpret the multimeter's specifications.

Number of Digits and Overrange

The “number of digits” specification is the most fundamental, and sometimes, the most confusing characteristic of a multimeter. The number of digits is equal to the maximum number of “9’s” the multimeter can measure or display. This indicates the number of *full digits*. Most multimeters have the ability to overrange and add a partial or “ $\frac{1}{2}$ ” digit.

For example, the HP 34401A can measure 9.99999 Vdc on the 10 V range. This represents six full digits of resolution. The multimeter can also overrange on the 10 V range and measure up to a maximum of 12.00000 Vdc. This corresponds to a $6\frac{1}{2}$ -digit measurement with 20% overrange capability.

Sensitivity

Sensitivity is the minimum level that the multimeter can detect for a given measurement. Sensitivity defines the ability of the multimeter to respond to small changes in the input level. For example, suppose you are monitoring a 1 mVdc signal and you want to adjust the level to within $\pm 1 \mu\text{V}$. To be able to respond to an adjustment this small, this measurement would require a multimeter with a sensitivity of at least $1 \mu\text{V}$. You could use a $6\frac{1}{2}$ -digit multimeter *if* it has a 1 Vdc or smaller range. You could also use a $4\frac{1}{2}$ -digit multimeter with a 10 mVdc range.

For ac voltage and ac current measurements, note that the smallest value that can be measured is different from the sensitivity. For the HP 34401A, these functions are specified to measure down to 1% of the selected range. For example, the multimeter can measure down to 1 mV on the 100 mV range.

Resolution

Resolution is the numeric ratio of the maximum displayed value divided by the minimum displayed value on a selected range. Resolution is often expressed in percent, parts-per-million (ppm), counts, or bits. For example, a 6^{1/2}-digit multimeter with 20% overrange capability can display a measurement with up to 1,200,000 counts of resolution. This corresponds to about 0.0001% (1 ppm) of full scale, or 21 bits including the sign bit. All four specifications are equivalent.

Accuracy

Accuracy is a measure of the “exactness” to which the multimeter’s measurement uncertainty can be determined *relative to* the calibration reference used. Absolute accuracy includes the multimeter’s relative accuracy specification plus the known error of the calibration reference relative to national standards (such as the U.S. National Institute of Standards and Technology). To be meaningful, the accuracy specifications must be accompanied with the conditions under which they are valid. These conditions should include temperature, humidity, and time.

There is no standard convention among multimeter manufacturers for the confidence limits at which specifications are set. The table below shows the probability of non-conformance for *each specification* with the given assumptions.

Specification Criteria	Probability of Failure
Mean ± 2 sigma	4.5%
Mean ± 3 sigma	0.3%
Mean ± 4 sigma	0.006%

Variations in performance from reading to reading, and instrument to instrument, decrease for increasing number of sigma for a given specification. This means that you can achieve greater actual measurement precision for a specific accuracy specification number. The HP 34401A is designed and tested to meet performance better than mean ±4 sigma of the published accuracy specifications.

Transfer Accuracy

Transfer accuracy refers to the error introduced by the multimeter due to noise and short-term drift. This error becomes apparent when comparing two nearly-equal signals for the purpose of “transferring” the known accuracy of one device to the other.

24-Hour Accuracy

The 24-hour accuracy specification indicates the multimeter’s relative accuracy over its full measurement range for short time intervals and within a stable environment. Short-term accuracy is usually specified for a 24-hour period and for a $\pm 1^{\circ}\text{C}$ temperature range.

90-Day and 1-Year Accuracy

These long-term accuracy specifications are valid for a $23^{\circ}\text{C} \pm 5^{\circ}\text{C}$ temperature range. These specifications include the initial calibration errors plus the multimeter’s long-term drift errors.

Temperature Coefficients

Accuracy is usually specified for a $23^{\circ}\text{C} \pm 5^{\circ}\text{C}$ temperature range. This is a common temperature range for many operating environments. You must add additional temperature coefficient errors to the accuracy specification if you are operating the multimeter outside a $23^{\circ}\text{C} \pm 5^{\circ}\text{C}$ temperature range (the specification is per $^{\circ}\text{C}$).

Configuring for Highest Accuracy Measurements

The measurement configurations shown below assume that the multimeter is in its power-on or reset state. It is also assumed that manual ranging is enabled to ensure proper full scale range selection.

DC Voltage, DC Current, and Resistance Measurements:

- Set the resolution to 6 digits (you can use the 6 digits slow mode for further noise reduction).
- Set the input resistance to greater than 10 G Ω (for the 100 mV, 1 V, and 10 V ranges) for the best dc voltage accuracy.
- Use 4-wire ohms for the best resistance accuracy.
- Use Math Null to null the test lead resistance for 2-wire ohms, and to remove interconnection offset for dc voltage measurements.

AC Voltage and AC Current Measurements:

- Set the resolution to 6 digits.
- Select the slow ac filter (3 Hz to 300 kHz).

Frequency and Period Measurements:

- Set the resolution to 6 digits.

Quick Start

Quick Start

One of the first things you will want to do with your multimeter is to become acquainted with its front panel. We have written the exercises in this chapter to prepare the multimeter for use and help you get familiar with some of its front-panel operations.

The front panel has two rows of keys to select various functions and operations. Most keys have a *shifted* function printed in *blue* above the key. To perform a shifted function, press **Shift** (the **Shift** annunciator will turn on). Then, press the key that has the desired label above it. For example, to select the dc current function, press **Shift** **DC V** .

If you accidentally press **Shift** , just press it again to turn off the **Shift** annunciator.

The rear cover of this book is a fold-out Quick Reference Guide. On this cover you will find a quick summary of various multimeter features.

To Prepare the Multimeter for Use

The following steps help you verify that the multimeter is ready for use.

1 Check the list of supplied items.

Verify that you have received the following items with your multimeter. If anything is missing, contact your nearest Hewlett-Packard Sales Office.

- One test lead kit.
- One power cord.
- This *Service Guide*.
- One *User's Guide*.
- One folded *Quick Reference* card.
- Certificate of Calibration.

2 Connect the power cord and turn on the multimeter.

The front-panel display will light up while the multimeter performs its power-on self-test. The HP-IB bus address is displayed. Notice that the multimeter powers up in the *dc voltage* function with autoranging enabled.

*To review the power-on display with all annunciators turned on, hold down **Shift** as you turn on the multimeter.*

3 Perform a *complete self-test*.

The *complete self-test* performs a more extensive series of tests than those performed at power-on. Hold down **Shift** as you press the Power switch to turn on the multimeter; *hold down the key for more than 5 seconds*. The self-test will begin when you release the key.

If the self-test is successful, "PASS" is displayed. If the self-test is not successful, "FAIL" is displayed and the **ERROR** annunciator turns on.

If the Multimeter Does Not Turn On

Use the following steps to help solve problems you might encounter when turning on the multimeter. If you need more help, see chapter 6 for instructions on returning the multimeter to Hewlett-Packard for service.

1 Verify that there is ac power to the multimeter.

First, verify that the multimeter's Power switch is in the "On" position. Also, make sure that the power cord is firmly plugged into the power module on the rear panel. You should also make sure that the power source you plugged the multimeter into is energized.

2 Verify the power-line voltage setting.

The line voltage is set to the proper value for your country when the multimeter is shipped from the factory. Change the voltage setting if it is not correct. The settings are: 100, 120, 220, or 240 Vac (for 230 Vac operation, use the 220 Vac setting).

See the next page if you need to change the line-voltage setting.

3 Verify that the power-line fuse is good.

The multimeter is shipped from the factory with a 250 mA fuse installed. This is the correct fuse for all line voltages.

See the next page if you need to replace the power-line fuse.

To replace the 250 mA fuse, order HP part number 2110-0817.

1 Remove the power cord. Remove the fuse-holder assembly from the rear panel.

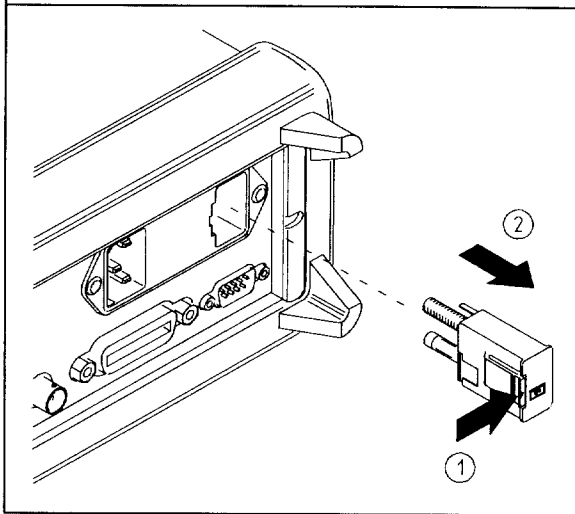

2 Remove the line-voltage selector from the assembly.

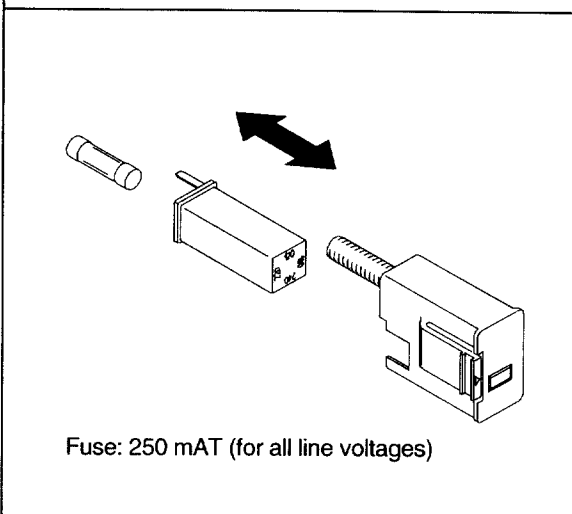

3 Rotate the line-voltage selector until the correct voltage appears in the window.

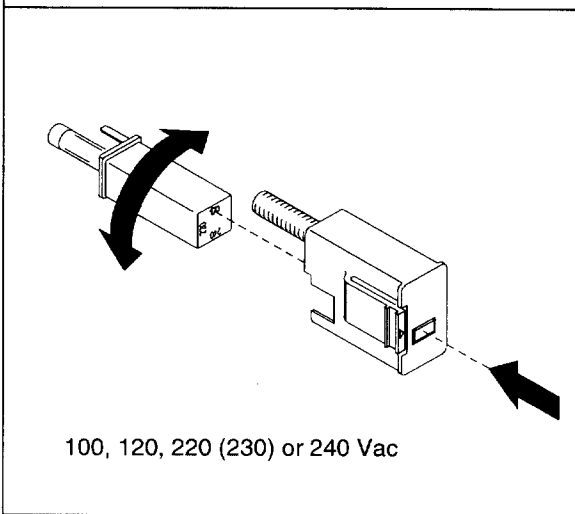

4 Replace the fuse-holder assembly in the rear panel.

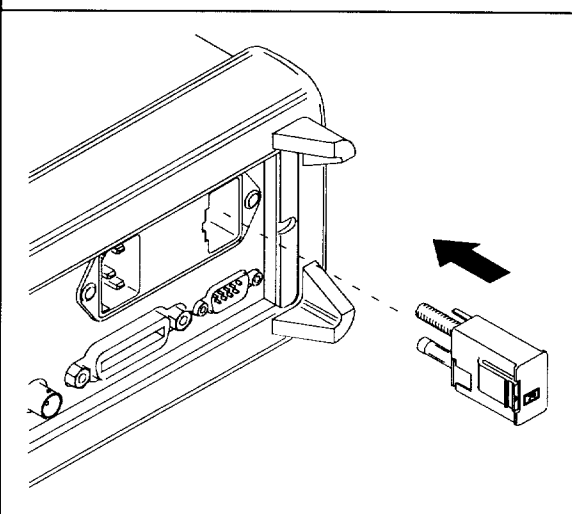

Verify that the correct line voltage is selected and the power-line fuse is good.

To Adjust the Carrying Handle

To adjust the position, grasp the handle by the sides and *pull outward*. Then, rotate the handle to the desired position.

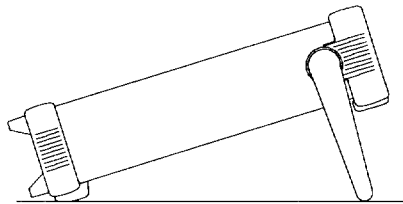
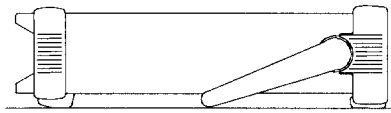

Bench-top viewing positions

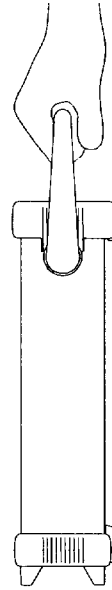

Carrying position

To Measure Voltage

Ranges: 100 mV, 1 V, 10 V, 100 V, 1000 V (750 Vac)
Maximum resolution: 100 nV (on 100 mV range)
AC technique: true RMS, ac-coupled

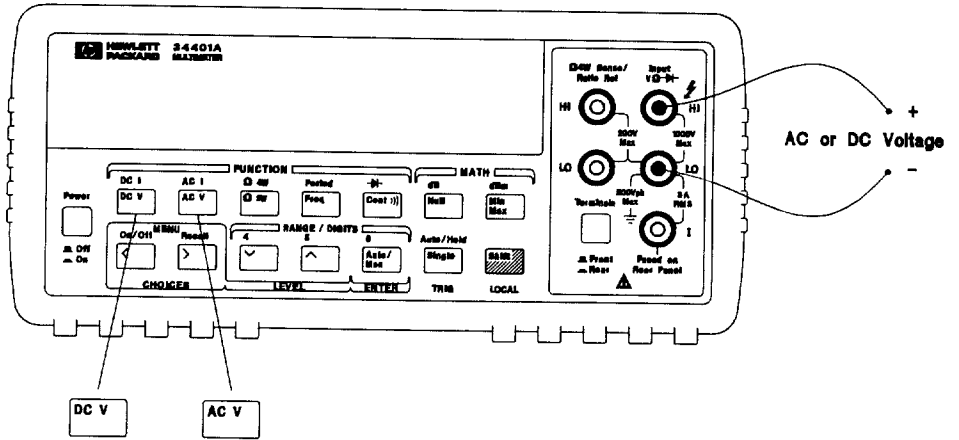

To Measure Resistance

Ranges: 100 Ω, 1 kΩ, 10 kΩ, 100 kΩ, 1 MΩ, 10 MΩ, 100 MΩ
Maximum resolution: 100 μΩ (on 100 ohm range)

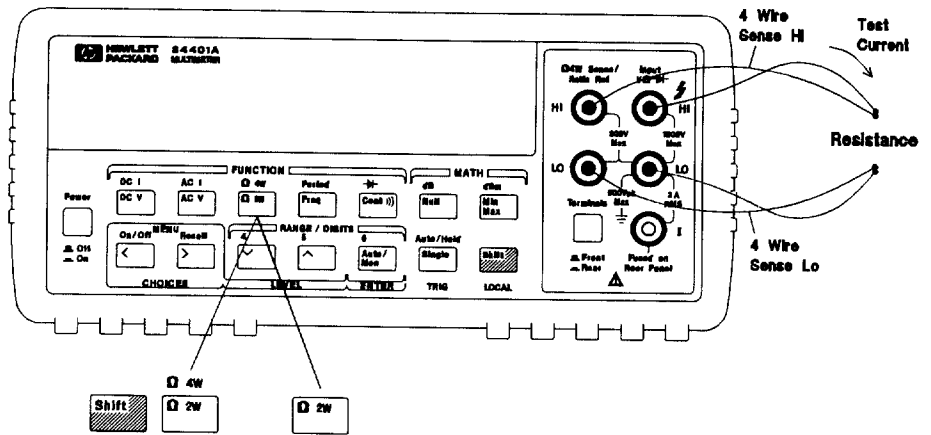

To Measure Current

Ranges: 10 mA (dc only), 100 mA (dc only), 1 A, 3 A
Maximum resolution: 10 nA (on 10 mA range)
AC technique: true RMS, ac-coupled

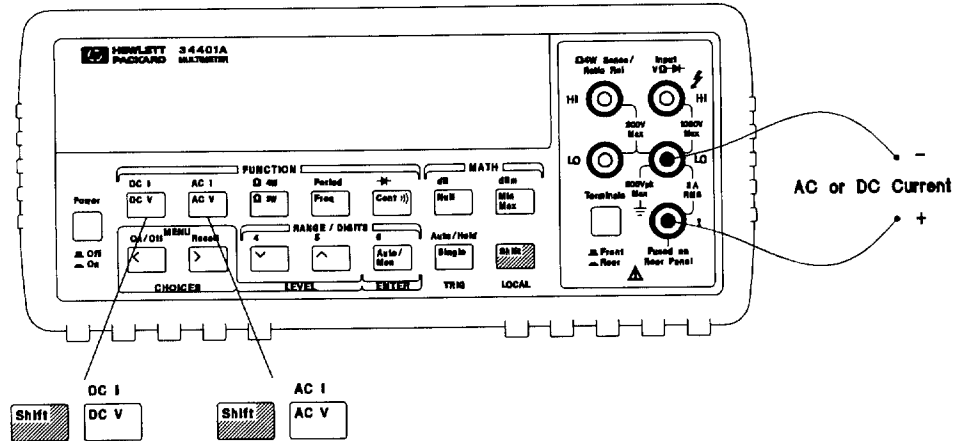

To Measure Frequency (or Period)

Measurement band: 3 Hz to 300 kHz (0.33 sec to 3.3 μ sec)
Input signal range: 100 mVac to 750 Vac
Technique: reciprocal counting

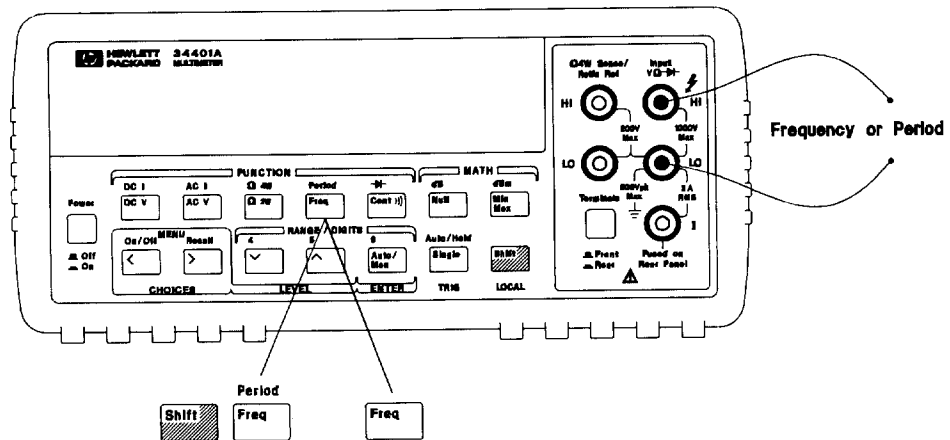

To Test Continuity

Test current source: 1 mA
 Maximum resolution: 0.1 Ω (range is fixed at 1 kohm)
 Beeper threshold: 1 Ω to 1000 Ω (beeps below adjustable threshold)

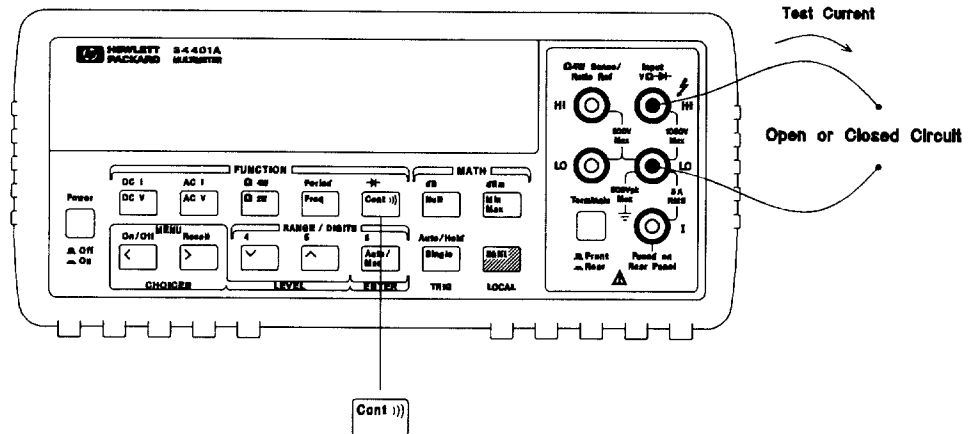

To Check Diodes

Test current source: 1 mA
 Maximum resolution: 100 μV (range is fixed at 1 Vdc)
 Beeper threshold: 0.3 volts $\leq V_{\text{measured}} \leq$ 0.8 volts (not adjustable)

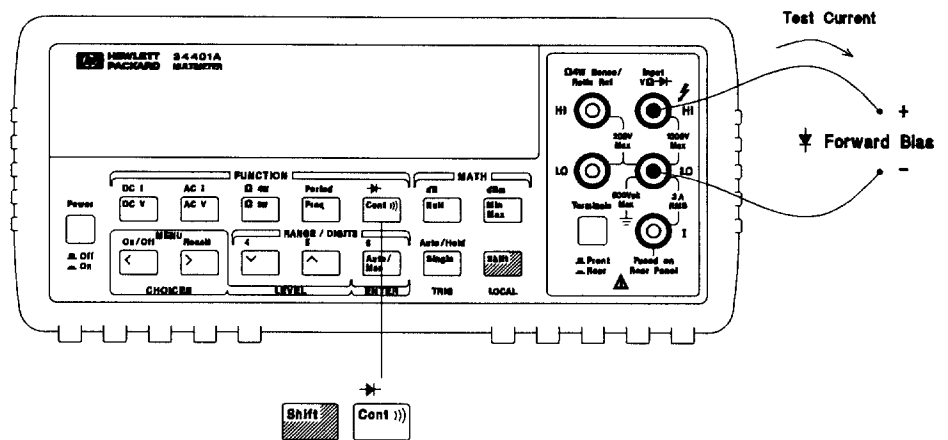

To Select a Range

You can let the multimeter automatically select the range using *autoranging* or you can select a fixed range using *manual ranging*.

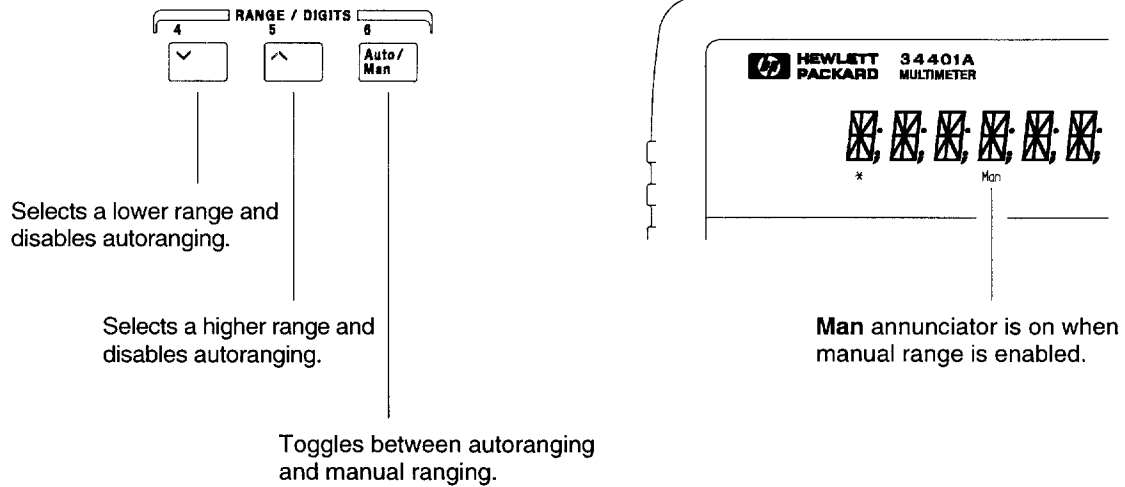

- Autoranging is selected at power-on and after a remote interface reset.
- Autorange thresholds:
 - Down range at <10% of range
 - Up range at >120% of range
- If the input signal is greater than the present range can measure, the multimeter will give an *overload* indication (“OVL D”).
- For frequency and period measurements from the front panel, ranging applies to the signal’s input *voltage*, not its frequency.
- The range is fixed for continuity (1 k Ω range) and diode (1 Vdc range).

Ranging is local to the selected function. This means that you can select the ranging method (auto or manual) for each function independently. When manually ranging, the selected range is local to the function; the multimeter remembers the range when you switch between functions.

To Set the Resolution

You can set the display resolution to 4½, 5½, or 6½ digits either to optimize measurement speed or noise rejection. In this book, the most significant digit (leftmost on the display) is referred to as the “½” digit, since it can only be a “0” or “1.”

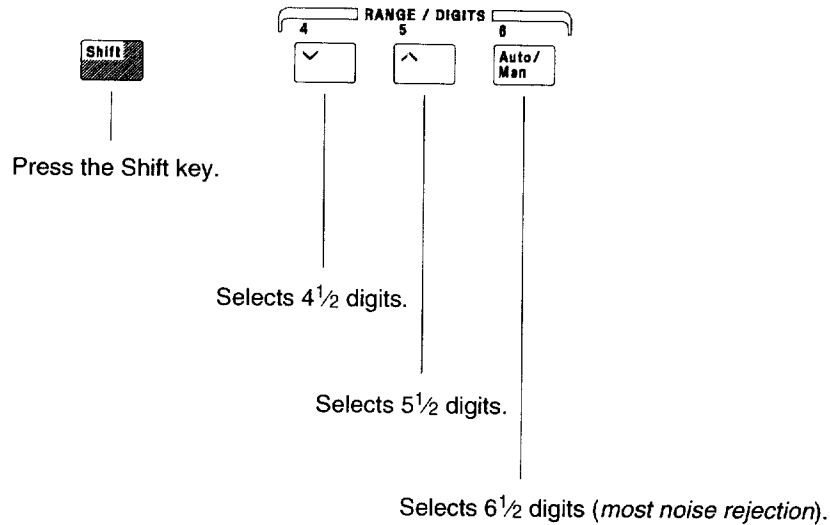

- The resolution is set to 5½ digits at power-on and after a remote interface reset.
- The resolution is fixed at 5½ digits for continuity and diode tests.
- You can also vary the number of digits displayed using the arrow keys (however, the integration time is not changed).

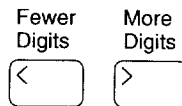

Resolution is local to the selected function. This means that you can select the resolution for each function independently. The multimeter remembers the resolution when you switch between functions.

To Make Null (Relative) Measurements

Each null measurement, also called *relative*, is the difference between a stored null value and the input signal.

Result = *reading* - *null value*

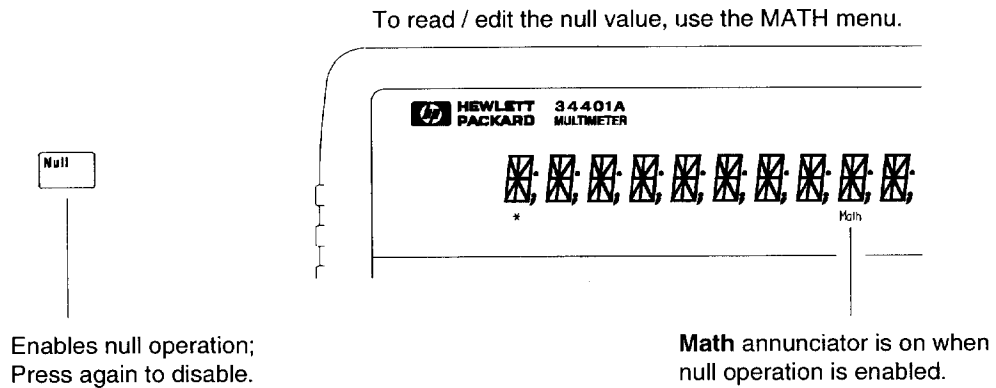

- You can make null measurements with any function except continuity, diode, or ratio. The null operation is local to the selected function; when you change functions, null is disabled.
- To null the test lead resistance for more accurate two-wire ohms measurements, short the ends of the test leads together and then press **Null** .
- The first reading taken after you press **Null** is stored as the null value in the Null Register. Any previously stored value is replaced with the new value.
- After enabling null, you can edit the stored null value by pressing **Shift** **>** (Menu Recall). This takes you to the “NULL VALUE” command in the MATH MENU (*only if null is enabled*). Go down to the “parameter” level, and then edit the displayed value.
- The null register is cleared when you change functions, turn null off, turn off the power, or perform a remote interface reset.

To Store Minimum and Maximum Readings

You can store the minimum and maximum readings during a series of measurements. The following discussion shows how to read the minimum, maximum, average, and reading count.

To read the minimum, maximum, average, and count, use the MATH menu.

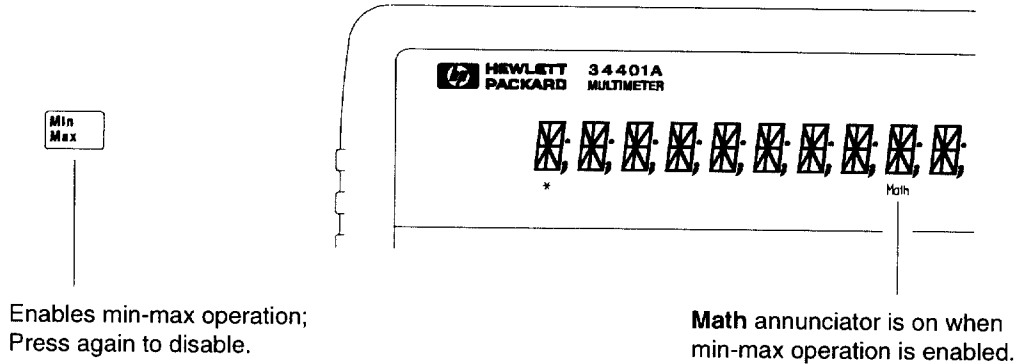

- You can use min-max with any function except continuity or diode test. The min-max operation is local to the selected function; when you change functions, min-max is disabled.
- After enabling min-max, you can read the stored minimum, maximum, average, and count by pressing **Shift** **>** (Menu Recall). This takes you to the "MIN-MAX" command in the MATH MENU (*only if min-max is enabled*). Go down to the "parameter" level, and then read the values by pressing **<** or **>**.
- The stored values are cleared when you turn min-max off, turn off the power, or perform a remote interface reset.
- The average is of all readings taken since min-max was enabled (not just the average of the stored minimum and maximum). The count is the total number of readings taken since min-max was enabled.

To Make dB Measurements

Each dB measurement is the difference between the input signal and a stored relative value, with both values converted to dBm.

$$dB = \text{reading in dBm} - \text{relative value in dBm}$$

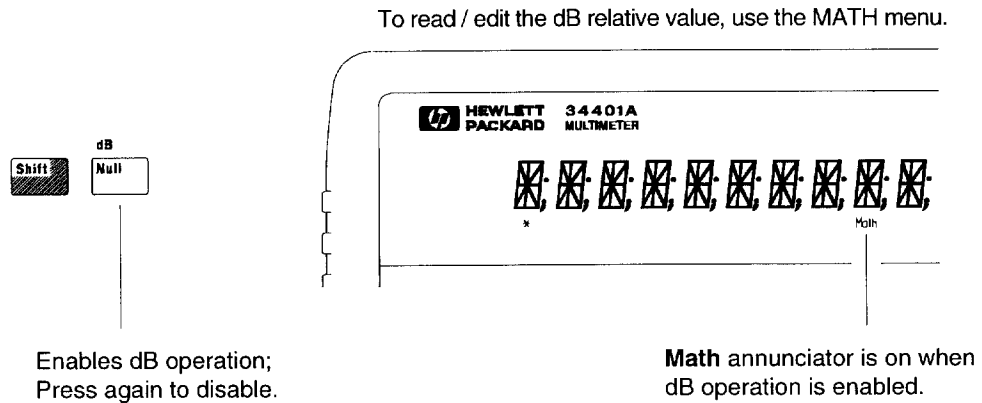

- Select **DC V** or **AC V**.
- The first reading taken after you enable dB measurements is converted to dBm and is stored as the relative value in the dB Relative Register. Any previously stored value is replaced with the new value.
- After enabling dB operations, you can edit the relative value by pressing **Shift** **>** (Menu Recall). This takes you to the “dB REL” command in the MATH MENU (*only if dB is enabled*). Go down to the “parameter” level, and then edit the value displayed.
- The register is cleared when you change functions, turn dB off, turn off the power, or perform a remote interface reset.

To Make dBm Measurements

The dBm operation calculates the power delivered to a resistance referenced to 1 milliwatt.

$$dBm = 10 \times \text{Log}_{10} (\text{reading}^2 / \text{reference resistance} / 1 \text{ mW})$$

To read / edit the dBm reference resistance, use the MATH menu.

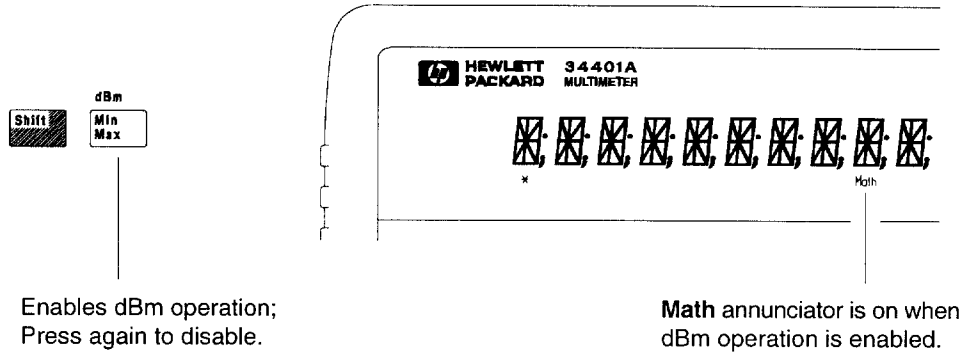

- Select **DC V** or **AC V**.
- The factory setting for the reference resistance is 600 Ω. To select a different value, press **Shift** **>** (Menu Recall) after enabling dBm operations. This takes you to the “dBm REF R” command in the MATH MENU (*only if dBm is enabled*).

Go down to the “parameter” level, and then select a value: 50, 75, 93, 110, 124, 125, 135, 150, 250, 300, 500, **600**, 800, 900, 1000, 1200, or 8000 ohms.

- The reference resistance is stored in *non-volatile* memory, and *does not* change when power has been off or after a remote interface reset.

To Trigger the Multimeter

You can trigger the multimeter from the front panel using *single trigger* or *auto trigger*.

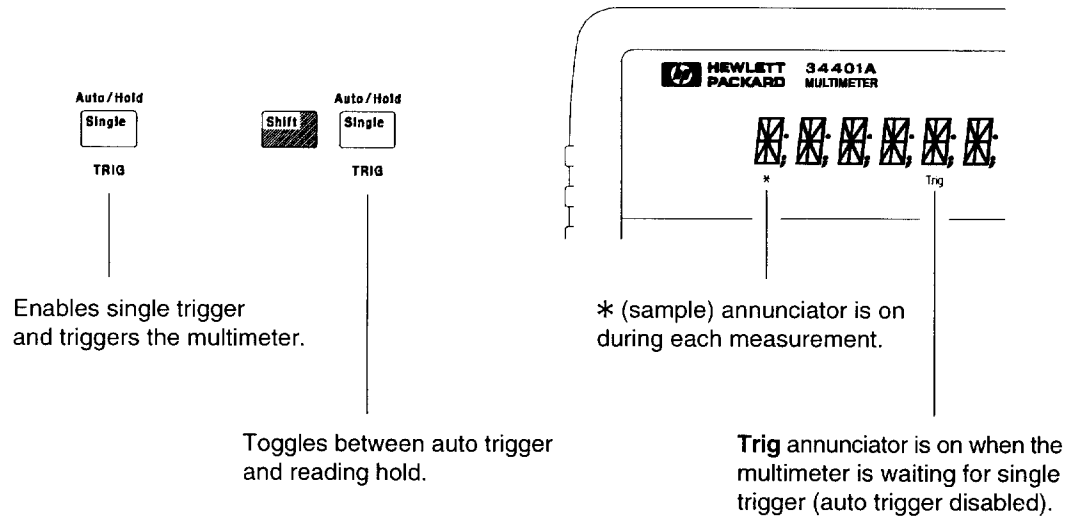

- Auto triggering is enabled when you turn on the multimeter. Notice that the * (sample) annunciator turns on during each measurement.
- Single triggering takes one reading each time you press **Single** and then waits for the next trigger. Continue pressing this key to trigger the multimeter.

Using an External Trigger

The external trigger mode is also enabled by pressing **Single**. It is like the single trigger mode except that you apply a trigger pulse to the rear-panel Ext Trig terminal. The multimeter is triggered on the negative edge of a TTL pulse.

The front-panel **Single** key is disabled when in remote.

To Make dcv:dcv Ratio Measurements

To calculate a ratio, the multimeter measures a dc reference voltage applied to the **Sense** terminals and the voltage applied to the **Input** terminals.

$$\text{Ratio} = \frac{\text{dc signal voltage}}{\text{dc reference voltage}}$$

To enable ratio measurements, use the MEAS menu.

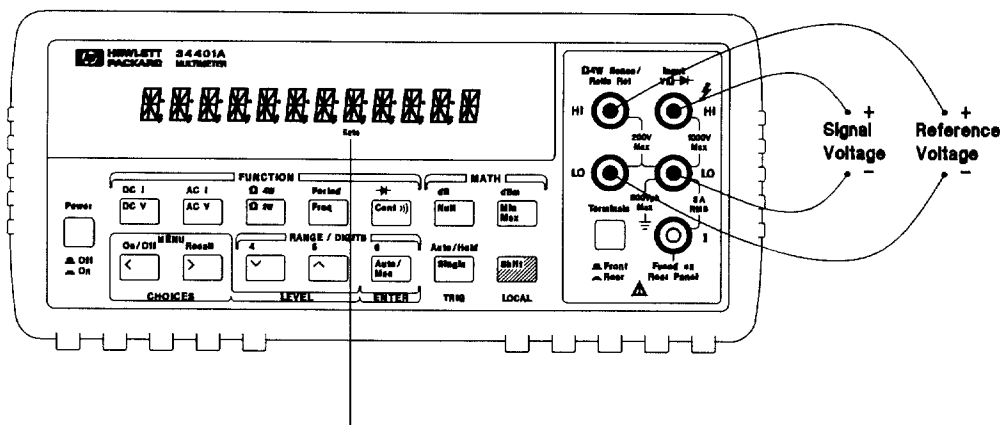

Ratio annunciator is on when ratio measurements are enabled.

- At the **Sense** terminals, the reference voltage measurement function is always *dc voltage* and has a maximum measurable input of ± 12 Vdc. Autoranging is automatically selected for reference voltage measurements on the **Sense** terminals.
- The **Input LO** and **Sense LO** terminals must have a common reference and cannot have a voltage difference greater than ± 2 volts.
- The specified measurement range applies *only* to the signal connected to the **Input** terminals. The signal on the **Input** terminals can be any dc voltage up to 1000 volts.

Front-Panel Display Formats

-H.DDD,DDD EFFF

Front-panel display format.

- Negative sign or blank (positive)
- H "1/2" digit (0 or 1)
- D Numeric digits
- E Exponent (m, k, M)
- F Measurement units (VDC, OHM, HZ, dB)

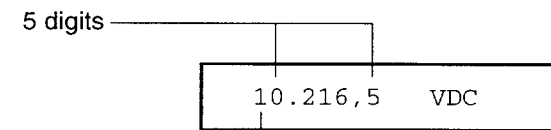

This is the 10 Vdc range, 5^{1/2} digits are displayed.

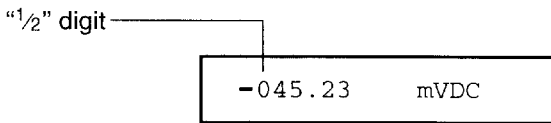

This is the 100 mVdc range, 4^{1/2} digits are displayed.

113.325,6 OHM

This is the 100 ohm range, 6^{1/2} digits are displayed.

OVL.D mVDC

This is an overload indication on the 100 mVdc range.

To Rack Mount the Multimeter

You can mount the multimeter in a standard 19-inch rack cabinet using one of three optional kits available. Instructions and mounting hardware are included with each rack-mounting kit. Any HP *System II* instrument of the same size can be rack-mounted beside the HP 34401A.

Remove the carrying handle, and the front and rear rubber bumpers, before rack-mounting the multimeter.

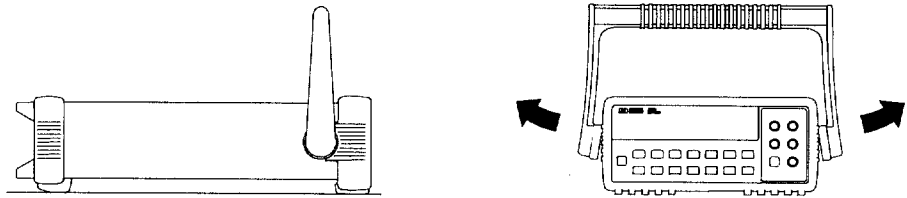

To remove the handle, rotate it to the vertical position and pull the ends outward.

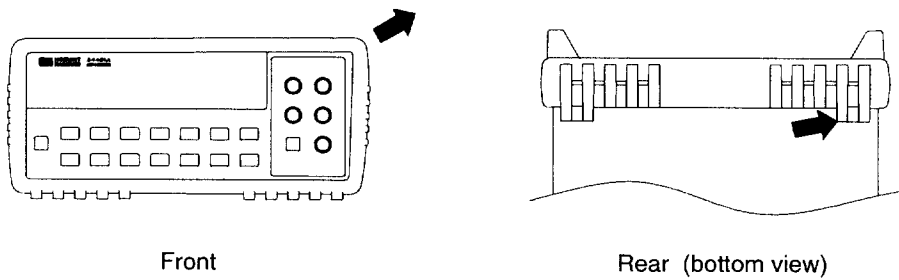

Front

Rear (bottom view)

To remove the rubber bumper, stretch a corner and then slide it off.

Chapter 2 Quick Start
To Rack Mount the Multimeter

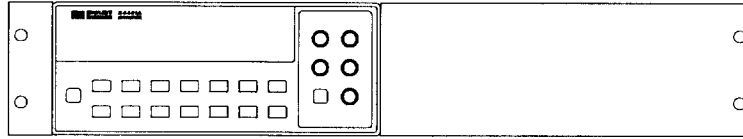

To rack mount a single instrument, order adapter kit 5062-3972.

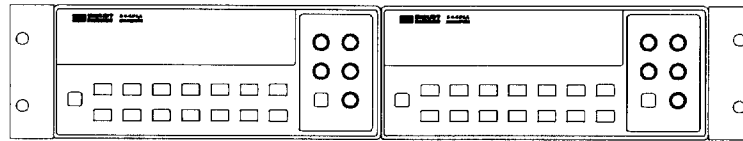

To rack mount two instruments side-by-side, order lock-link kit 5061-9694 and flange kit 5062-3974.

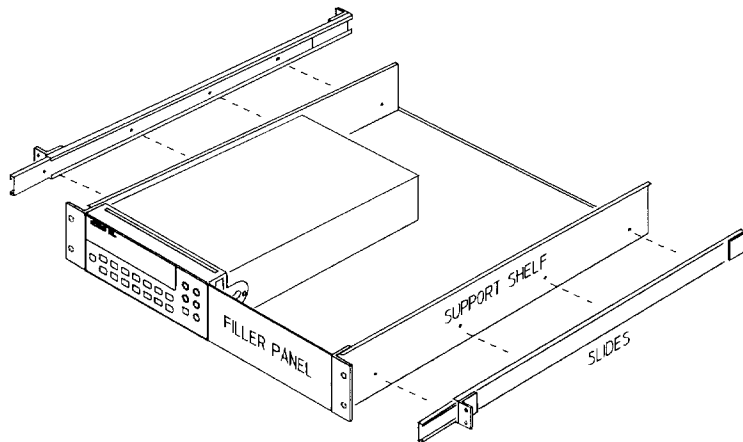

To install one or two instruments in a sliding support shelf, order shelf 5062-3996, and slide kit 1494-0015 (for a single instrument, also order filler panel 5062-4022).

Menu Tutorial

Menu Tutorial

By now you should be familiar with the FUNCTION and RANGE / DIGITS groups of front-panel keys. You should also understand how to make front-panel connections for the various types of measurements. If you are not familiar with this information, we recommend that you read chapter 2, "Quick Start," starting on page 27.

This chapter introduces you to the front panel menu. It describes each menu and takes you step-by-step through calibration examples. See chapter 3, "Features and Functions" in the *User's Guide* for a complete discussion of the multimeter's capabilities and operation.

Front-Panel Menu Reference

A: MEASurement MENU

1: AC FILTER ➔ 2: CONTINUITY ➔ 3: INPUT R ➔ 4: RATIO FUNC ➔ 5: RESOLUTION

1: AC FILTER	Selects the slow, medium, or fast ac filter.
2: CONTINUITY	Sets the continuity beeper threshold (1 Ω to 1000 Ω).
3: INPUT R	Sets the input resistance for dc voltage measurements.
4: RATIO FUNC	Enables the dcv:dcv ratio function.
5: RESOLUTION	Selects the measurement resolution.

B: MATH MENU

1: MIN-MAX ➔ 2: NULL VALUE ➔ 3: dB REL ➔ 4: dBm REF R ➔ 5: LIMIT TEST ➔ 6: HIGH LIMIT ➔ 7: LOW LIMIT

1: MIN-MAX	Recalls the stored minimum, maximum, average, and reading count.
2: NULL VALUE	Recalls or sets the null value stored in the null register.
3: dB REL	Recalls or sets the dBm value stored in the dB relative register.
4: dBm REF R	Selects the dBm reference resistance value.
5: LIMIT TEST	Enables or disables limit testing.
6: HIGH LIMIT	Sets the upper limit for limit testing.
7: LOW LIMIT	Sets the lower limit for limit testing.

C: TRIGger MENU

1: READ HOLD ➔ 2: TRIG DELAY ➔ 3: N SAMPLES

1: READ HOLD	Sets the reading hold sensitivity band.
2: TRIG DELAY	Specifies a time interval which is inserted before a measurement.
3: N SAMPLES	Sets the number of samples per trigger.

D: SYStem MENU

1: RDGS STORE ➔ 2: SAVED RDGS ➔ 3: ERROR ➔ 4: TEST ➔ 5: DISPLAY ➔ 6: BEEP ➔ 7: COMMA ➔ 8: REVISION

1: RDGS STORE	Enables or disables reading memory.
2: SAVED RDGS	Recalls readings stored in memory (up to 512 readings).
3: ERROR	Retrieves errors from the error queue (up to 20 errors).
4: TEST	Performs a complete self-test.
5: DISPLAY	Enables or disables the front-panel display.
6: BEEP	Enables or disables the beeper function.
7: COMMA	Enables or disables a comma separator between digits on the display.
8: REVISION	Displays the multimeter's firmware revision codes.

E: Input / Output MENU

1: HP-IB ADDR ➔ 2: INTERFACE ➔ 3: BAUD RATE ➔ 4: PARITY ➔ 5: LANGUAGE

1: HP-IB ADDR	Sets the HP-IB bus address (0 to 31).
2: INTERFACE	Selects the HP-IB or RS-232 interface.
3: BAUD RATE	Selects the baud rate for RS-232 operation.
4: PARITY	Selects even, odd, or no parity for RS-232 operation.
5: LANGUAGE	Selects the interface language: SCPI, HP 3478, or Fluke 8840/42.

F: CALibration MENU*

1: SECURED ➔ [1: UNSECURED] ➔ [2: CALIBRATE] ➔ 3: CAL COUNT ➔ 4: MESSAGE

1: SECURED	The multimeter is secured against calibration; enter code to unsecure.
1: UNSECURED	The multimeter is unsecured for calibration; enter code to secure.
2: CALIBRATE	Performs complete calibration of present function; must be UNSECURED.
3: CAL COUNT	Reads the total number of times the multimeter has been calibrated.
4: MESSAGE	Reads the calibration string (up to 12 characters) entered from remote.

* The commands enclosed in square brackets ([]) are "hidden" unless the multimeter is UNSECURED for calibration.

A Front-Panel Menu Tutorial

This section is a step-by-step tutorial which shows how to use the front-panel menu. We recommend that you spend a few minutes with this tutorial to get comfortable with the structure and operation of the menu.

The menu is organized in a top-down tree structure with three levels (*menus*, *commands*, and *parameters*). You move down or up the menu tree to get from one *level* to the next. Each of the three levels has several horizontal *choices* which you can view by moving left or right .

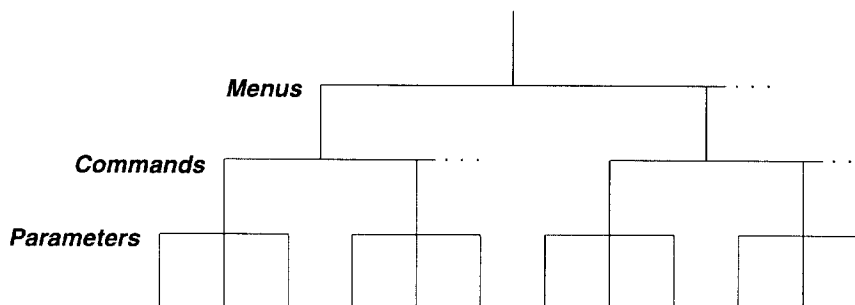

- To *turn on* the menu, press Shift Menu On/Off .
- To *turn off* the menu, press Shift Menu On/Off , or press any of the function or math keys on the top row of front-panel keys.
- To *execute* a menu command, press Enter .
- To *recall* the last menu command that was executed, press Shift Recall .

MESSAGES DISPLAYED DURING MENU USE

TOP OF MENU You pressed \uparrow while on the “menus” level; this is the top level of the menu and you cannot go any higher.

To turn off the menu, press $\text{Shift} \leftarrow$ (Menu On/Off). To move across the choices on a level, press \leftarrow or \rightarrow . To move down a level, press \downarrow .

MENUS You are on the “menus” level. Press \leftarrow or \rightarrow to view the choices.

COMMANDS You are on the “commands” level. Press \leftarrow or \rightarrow to view the command choices within the selected menu group.

PARAMETER You are on the “parameter” level. Press \leftarrow or \rightarrow to view and edit the parameter for the selected command.

MENU BOTTOM You pressed \downarrow while on the “parameter” level; this is the bottom level of the menu and you cannot go any lower.

To turn off the menu, press $\text{Shift} \leftarrow$ (Menu On/Off). To move up a level, press \uparrow .

CHANGE SAVED The change made on the “parameter” level is saved. This is displayed after you press Auto/Man (Menu Enter) to execute the command.

MIN VALUE The value you specified on the “parameter” level is too small for the selected command. The minimum value allowed is displayed for you to edit.

MAX VALUE The value you specified on the “parameter” level is too large for the selected command. The maximum value allowed is displayed for you to edit.

EXITING MENU You will see this message if you turn off the menu by pressing $\text{Shift} \leftarrow$ (Menu On/Off) or a front-panel function/math key. You did not edit any values on the “parameter” level and changes were NOT saved.

NOT ENTERED You will see this message if you turn off the menu by pressing $\text{Shift} \leftarrow$ (Menu On/Off) or a front-panel function/math key. You did some editing of parameters but the changes were NOT saved. Press Auto/Man (Menu Enter) to save changes made on the “parameter” level.

NOT RELEVANT The selected math operation is NOT valid for the function in use.

Menu Example 1

The following steps show you how to turn on the menu, move up or down between levels, move across the choices on each level, and turn off the menu. In this example, you will unsecure the multimeter for calibration.

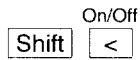

1 Turn on the menu.

You enter the menu on the “menus” level. The MEAS MENU is your first choice on this level.

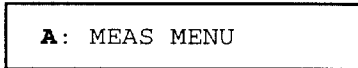

2 Move across to the CAL MENU choice on this level.

There are six menu group choices available on the “menus” level. Each choice has a letter prefix for easy identification (A: , B: , etc.).



3 Move down to the “commands” level within the CAL MENU.

Either SECURED or UNSECURED is the first command on this level. If SECURED is displayed, you must unsecure the multimeter so that calibrations can be performed.





4 Move down to the “parameters” level.

The multimeter will wait for the security code to be entered.

```
^000000 CODE
```

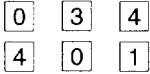

5 Unsecure the multimeter by entering the security code.

The security code is set to “HP034401” when the multimeter is shipped from the factory. The security code is stored in *non-volatile* memory, and *does not* change when power has been off or after a remote interface reset.



Use and to move left or right between digits. Use or to increment or decrement numbers.

If you have not changed the security code from its factory setting, you can unsecure the multimeter by entering “034401” from the front panel. Only the last six characters are recognized from the front panel and they must be numeric characters only.

```
^034401 CODE
```

We recommend that you use a unique SECURE code for each multimeter to obtain the maximum benefit from the electronic calibration security features of the multimeter.

To secure the multimeter again, return to the parameter level of the UNSECURED command and enter a new security code.

For further information on the calibration security features of the multimeter, see “Calibration Security Code” on page 73.

Menu Example 2

Some commands in the menu require that you enter a numeric parameter value. The following steps show you how to enter a number in the menu. In this example, you will set the calibration value to 0.0 volts. *For this example you must apply a short between HI-LO Sense and HI-LO Input.*

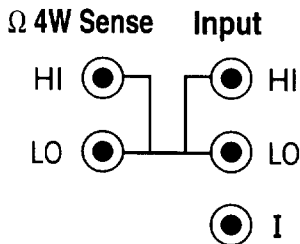

Caution *Completing this example will perform a zero calibration. Refer to chapter 4, "Calibration Procedures," before attempting this example.*

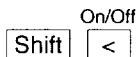

1 Turn on the menu.

You enter the menu on the "menus" level. The MEAS MENU is your first choice on this level.

A: MEAS MENU



2 Move across to the CAL MENU choice on this level.

There are six menu group choices available on the "menus" level. Each choice has a letter prefix for easy identification (**A:** , **B:** , etc.).

F: CAL MENU



3 Move down to the “commands” level within the CAL MENU.

Either SECURED or UNSECURED is the first command on this level. To perform a calibration, UNSECURED must be displayed. If SECURED is displayed, see example 1 in this chapter to unsecure for calibration.

1: UNSECURED



4 Move across to the CALIBRATE command on this level.

There are four command choices available in the CAL MENU. Each choice on this level has a number prefix for easy identification (1: , 2: , etc.).

2: CALIBRATE



5 Move down to edit the CALIBRATE VALUE parameter.

The calibration value should read 100.000,0 mVDC when you come to this point in the menu for the first time (when set to 100 mVdc range). For this example, you will set the calibration value to 0.0 volts.

^ 100.000,0 mVDC

When you see the flashing “^” on the left side of the display, you can abort the edit and return to the “commands” level by pressing .



6 Move the flashing cursor over to edit the first digit.

Notice that the leftmost digit is flashing.

100.000,0 mVDC



7 Decrement the first digit until “0” is displayed.

You decrement or increment each digit independently. Neighboring digits are not affected.

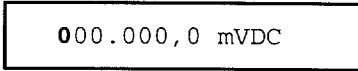

8 Move the flashing cursor over to the “units” location.

Notice that the units are flashing on the right side of the display.

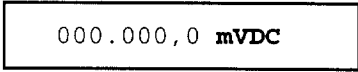

9 Increase the displayed number by a factor of 10.

Notice that the position of the decimal point changes and the displayed number increases by a factor of 10.

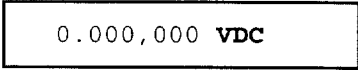

10 Save the change and turn off the menu.

The multimeter beeps and displays a message to show that the change is now in effect. You are then exited from the menu.

The zero offset calibration procedure determines new calibration constants for each function and range. Separate calibration is required for the front and rear terminals.

Calibration
Procedures

Calibration Procedures

- Hewlett-Packard Calibration Services 61
- Calibration Interval 61
- Time Required for Calibration 61
- Automating Calibration Procedures 62
- Recommended Test Equipment 63
- Test Considerations 64
- Performance Verification Tests 65
- Zero Offset Verification 67
- Gain Verification 69
- Optional AC Performance Verification Tests 72
- Calibration Security Code 73
- Calibration Count 75
- Calibration Message 75
- Calibration Procedures 76
- Aborting a Calibration in Progress 76
- Zero Adjustment 77
- Gain Adjustment 79
- Optional Gain Calibration Procedures 82
- Understanding the AC Signal Filter 85
- Understanding Resolution 86
- Error Messages 89

The performance verification tests use the multimeter's specifications listed in chapter 1, "Specifications," starting on page 11.

Closed-Case Electronic Calibration The multimeter features closed-case electronic calibration since there are no internal mechanical adjustments required. The multimeter automatically prompts you for the required full-scale input when performing a range calibration. The multimeter measures the applied input and calculates correction factors based upon the input reference value you specify. The new correction factors are stored in non-volatile memory until the next calibration adjustment is performed. (Non-volatile memory does not change when power has been off or after a remote interface reset.)

Hewlett-Packard Calibration Services

When your multimeter is due for calibration, contact your local Hewlett-Packard Service Center for a low-cost recalibration. The HP 34401A Multimeter is supported on automated calibration systems which allow Hewlett-Packard to provide this service at competitive prices. Calibrations to MIL-STD-45662 are also available at competitive prices.

Calibration Interval

The multimeter should be calibrated on a regular interval determined by the measurement accuracy requirements of your application. A 90-day interval is recommended for the most demanding applications, while a 1-year or 2-year interval may be adequate for less demanding applications. Hewlett-Packard does not recommend extending calibration intervals beyond 2 years for any application.

Whatever calibration interval you select, Hewlett-Packard recommends that complete re-adjustment should always be performed at the calibration interval. This will increase your confidence that the HP 34401A will remain within specification for the next calibration interval. This criteria for re-adjustment provides the best measure of the multimeter's long-term stability. Performance data measured using this method can easily be used to extend future calibration intervals.

Time Required for Calibration

The HP 34401A can be automatically calibrated under computer control. With computer control you can perform the complete calibration procedure and performance verification tests in less than 20 minutes. Manual calibrations using a multi-function calibrator will take approximately 40 minutes.

Automating Calibration Procedures

You can automate the complete verification and adjustment procedures outlined in this chapter if you have access to programmable standards, such as a multi-function calibrator. You can program the instrument configurations specified for each test over the remote interface. You can then enter readback verification data into a test program and compare the results to the appropriate test limit values.

If you are using the HP 34401A in the Fluke 8840A/8842A emulation mode, you cannot use the Fluke calibration commands. You must use the SCPI calibration commands described in chapter 4 of the HP 34401A User's Guide.

You can also adjust the multimeter from the remote interface. Remote adjustment is similar to the local front-panel procedure. You can use a computer to perform the adjustment by first selecting the required function and range. The calibration value is sent to the multimeter and then the calibration is initiated over the remote interface. The multimeter must be unsecured prior to initiating the calibration procedure.

For further details on programming the multimeter, see chapter 3 and chapter 4 in the *HP 34401A User's Guide*.

Recommended Test Equipment

The test equipment recommended for the performance verification and adjustment procedures is listed below. If the exact instrument is not available, use the accuracy requirements shown to select substitute calibration standards.

Application	Recommended Equipment	Accuracy Requirements
Zero Calibration	None	4-terminal short using ONLY copper interconnections.
DC Voltage	Fluke 5700A	<1/5 dmm 24 hour spec ± 1 pmm linearity
DC Current	Fluke 5700A/5725A	<1/5 dmm 24 hour spec
Resistance	Fluke 5700A	<1/5 dmm 24 hour spec
AC Voltage	Fluke 5700A/5725A	<1/5 dmm 24 hour spec
AC Current	Fluke 5700A/5725A	<1/5 dmm 24 hour spec
Frequency	HP 3325A	<1/5 dmm 24 hour spec

A suggested alternate method would be to use the HP 3458A 8½ digit Digital Multimeter to measure less accurate yet stable sources. The output value measured from the source can be entered into the HP 34401A Multimeter as the target calibration value.

Test Considerations

To ensure proper instrument operation, verify that you have selected the correct power-line voltage prior to attempting any test procedure in this chapter. See chapter 2, “Quick Start,” for more information.

Ensure that all measurement terminal connections (both front panel and rear panel) are removed while the multimeter’s internal self-test is being performed. Errors may be induced by ac signals present on the multimeter’s input terminals during a self-test. Long test leads can also act as an antenna causing pick-up of ac signals.

For optimum performance, all test procedures should comply with the following recommendations:

- Assure that the calibration ambient temperature is stable and between 18°C and 28°C.
- Assure ambient relative humidity is less than 80%.
- Allow a 2-hour warm-up period before verification or adjustment.
- Use only copper connections to minimize thermal offset voltages.
- Use shielded twisted Teflon® insulated cable to minimize high resistance errors.
- Keep cables as short as possible.
- Allow 5 minutes after handling input connections for thermal offset voltage settling.

Because the multimeter is capable of making highly accurate measurements, you *must* take special care to ensure that the calibration standards and test procedures used do not introduce additional errors. Ideally, the standards used to test and calibrate the multimeter should be an order of magnitude *more accurate* than each multimeter range full scale error specification.

For dc voltage, dc current, and resistance measurements, you should take care to ensure that the calibrator’s “0” output is correct. If necessary, the multimeter measurements can be referenced to the calibrator’s “0” output using the multimeter’s front-panel NULL function. You will need to repeat this procedure for each range of the measuring function being verified.

Performance Verification Tests

You can perform three different levels of performance verification tests:

- **Self-Test** A series of internal verification tests that give a high confidence that the multimeter is operational.
- **Quick Verification** A combination of the internal self-tests and selected verification tests.
- **Performance Verification Tests** An extensive set of tests that are recommended as an acceptance test when you first receive the multimeter or after performing adjustments.

Self-Test

A brief power-on self-test occurs automatically whenever you turn on the multimeter. This limited test assures that the multimeter is capable of operation.

To perform a complete self-test, including over 25 tests, hold down the **[Shift]** key as you press the Power switch to turn on the multimeter; *hold down the key for more than 5 seconds* (a complete description of these tests can be found in chapter 6.) The multimeter meter will automatically perform the complete self-test procedure when you release the key. The self-test will complete in approximately 20 seconds.

You can perform many tests individually (or all tests at once) using the TEST command in the SYS MENU. You can also perform a self-test from the remote interface. For further information, see chapter 3 in the *HP 34401A User's Guide*.

- If the self-test is successful, "PASS" is displayed on the front panel.
- If the self-test fails, "FAIL" is displayed and the **ERROR** annunciator turns on. If repair is required, see chapter 6, "Service," for further details.
- If all tests pass, you can have a high confidence (90%) that the multimeter is operational.

Quick Performance Check

The quick performance check is a combination of internal self-test and an abbreviated performance test (specified by the letter **Q** in the performance verification tests). This test provides a simple method to achieve high confidence in the multimeter's ability to functionally operate and meet specifications. These tests represent the absolute minimum set of performance checks recommended following any service activity. Auditing the multimeter's performance for the quick check points (designated by a **Q**) verifies performance for "normal" accuracy drift mechanisms. *This test does not check for abnormal component failures.*

To perform the quick performance check, do the following:

- Perform a complete self-test.
- Perform only the performance verification tests indicated with the letter **Q**.

If the multimeter fails the quick performance check, adjustment or repair is required.

Performance Verification Tests

The performance verification tests are recommended as acceptance tests when you first receive the multimeter. The acceptance test results should be compared against the 90-day test limits. You should use the 24-hour test limits only for verification within 24 hours after performing the adjustment procedure. After acceptance, you should repeat the performance verification tests with the next calibration interval.

If the multimeter fails performance verification, adjustment or repair is required.

ALL configurations shown assume that the multimeter starts from its power-on or remote reset state.

Zero Offset Verification

This procedure is used to check the zero offset performance of the multimeter. Verification checks are only performed for those functions and ranges with unique offset calibration constants. A low-thermal EMF four-terminal short is applied to the input of the multimeter. Measurements are checked for each function and range as described in the procedure below.

Zero Offset Verification Procedure

Configuration: 6½ digit (slow or fast resolution – MEAS MENU)

- 1 Make sure you have read “Test Considerations” on page 64.
- 2 Apply a 4-wire short (copper) across the **Input HI-LO** and **Sense HI-LO** terminals as shown below (front or rear terminal).

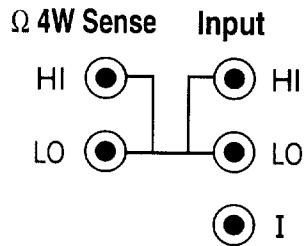

- 3 Select the shorted terminal set (front or rear) with the front/rear switch. *Separate zero offset calibration constants are stored for the front and rear input terminals.*
- 4 Select each function and range in the order shown in the table on the next page. Compare measurement results to the appropriate test limits shown in the table.

Chapter 4 Calibration Procedures
Zero Offset Verification

Input (Front/Rear)	Function	Quick Check	HP 34401A Range	Error From Nominal		
				24 hour	90 day	1 year
Open Open Open Open	DC Current	Q	10 mA 100 mA 1 A 3 A	$\pm 1 \mu\text{A}$ $\pm 4 \mu\text{A}$ $\pm 60 \mu\text{A}$ $\pm 600 \mu\text{A}$	$\pm 2 \mu\text{A}$ $\pm 5 \mu\text{A}$ $\pm 100 \mu\text{A}$ $\pm 600 \mu\text{A}$	$\pm 2 \mu\text{A}$ $\pm 5 \mu\text{A}$ $\pm 100 \mu\text{A}$ $\pm 600 \mu\text{A}$
Short Short Short Short Short	DC Volts	Q	100 mV 1 V 10 V 100 V 1000 V	$\pm 3 \mu\text{V}$ $\pm 6 \mu\text{V}$ $\pm 40 \mu\text{V}$ $\pm 600 \mu\text{V}$ $\pm 6 \text{mV}$	$\pm 3.5 \mu\text{V}$ $\pm 7 \mu\text{V}$ $\pm 50 \mu\text{V}$ $\pm 600 \mu\text{V}$ $\pm 10 \text{mV}$	$\pm 3.5 \mu\text{V}$ $\pm 7 \mu\text{V}$ $\pm 50 \mu\text{V}$ $\pm 600 \mu\text{V}$ $\pm 10 \text{mV}$
Short Short Short Short Short Short Short	2-Wire Ohms[1] and 4-Wire Ohms	Q	100 Ω 1 k Ω 10 k Ω 100 k Ω 1 M Ω 10 M Ω 100 M Ω	$\pm 3 \text{m}\Omega$ $\pm 5 \text{m}\Omega$ $\pm 50 \text{m}\Omega$ $\pm 500 \text{m}\Omega$ $\pm 10 \Omega$ $\pm 100 \Omega$ $\pm 10 \text{k}\Omega$	$\pm 4 \text{m}\Omega$ $\pm 10 \text{m}\Omega$ $\pm 100 \text{m}\Omega$ $\pm 1 \Omega$ $\pm 10 \Omega$ $\pm 100 \Omega$ $\pm 10 \text{k}\Omega$	$\pm 4 \text{m}\Omega$ $\pm 10 \text{m}\Omega$ $\pm 100 \text{m}\Omega$ $\pm 1 \Omega$ $\pm 10 \Omega$ $\pm 100 \Omega$ $\pm 10 \text{k}\Omega$

[1] For 2-wire ohms, these errors assume you are using Math Null. Without Math Null, an additional 200 m Ω of error must be added.

Q: Quick performance verification test points.

Caution Zero offset calibration using a multifunction calibrator is NOT recommended. The calibrator and cabling offset can be large and unstable causing poor offset calibration of the HP 34401A or any multimeter.

Note These offset tests should be verified for both the front and the rear input terminals.

Gain Verification

This procedure is used to check the “full scale” reading calibration of the multimeter. Verification checks are performed only for those functions and ranges with unique gain calibration constants. Begin verification by selecting a measuring function and range. *Make sure you have read “Test Considerations” on page 64.*

Gain Verification Test (DC V, Resistance, DC I)

Configuration: 6½ digit (slow or fast resolution – MEAS MENU)

Select each function and range in the order shown below. Compare measurement results to the appropriate test limits shown in the table. (Be certain to allow for appropriate source settling.)

Input (Front)	Function	Quick Check	HP 34401A Range	Error From Nominal		
				24 hour	90 day	1 year
100 mV 1 V 10 V -10 V 100 V 1000 V	DC Volts		100 mV	±6 μV	±7.5 μV	±8.5 μV
			1 V	±26 μV	±37 μV	±47 μV
		Q	10 V	±190 μV	±250 μV	±400 μV
			10 V	±190 μV	±250 μV	±400 μV
		Q	100 V	±2.6 mV	±4.1 mV	±5.1 mV
			1000 V	±26 mV	±45 mV	±55 mV
100 Ω 1 kΩ 10 kΩ 100 kΩ [2] 1 MΩ [2] 10 MΩ [2] 100 MΩ [2]	2-Wire Ohms[1] and 4-Wire Ohms		100 Ω	±6 mΩ	±12 mΩ	±14 mΩ
			1 kΩ	±25 mΩ	±90 mΩ	±110 mΩ
			10 kΩ	±250 mΩ	±900 mΩ	±1.1 Ω
			100 kΩ	±2.5 Ω	±9 Ω	±11 Ω
			1 MΩ	±30 Ω	±90 Ω	±110 Ω
		Q	10 MΩ	±1.6 kΩ	±2.1 kΩ	±4.1 kΩ
			100 MΩ	±310 kΩ	±810 kΩ	±810 kΩ
10 mA 100 mA 1 A 2 A	DC Current		10 mA	±1.5 μA	±5 μA	±7 μA
			100 mA	±14 μA	±35 μA	±55 μA
		Q	1 A	±560 μA	±900 μA	±1.1 mA
			3 A	±2.6 mA	±3.0 mA	±3.0 mA

[1] For 2-wire ohms, these errors assume you are using Math Null. Without Math Null, an additional 200 mΩ of error must be added.

[2] Use shielded twisted pair Teflon® insulated cables to reduce settling and noise errors.

Q: Quick performance verification test points.

Gain Verification**Gain Verification Test (AC V)**

Configuration: AC volts

6½ digit

AC FILTER slow (MEAS MENU)

- 1 Make sure you have read “Test Considerations” on page 64.
- 2 Select each function and range in the order shown below.
Compare measurement results to the appropriate test limits shown in the table. (Be certain to allow for appropriate source settling.)

Input (Front)	Input Frequency	Quick Check	HP 34401A Range	Error From Nominal		
				24 hour	90 day	1 year
10 mV	1 kHz		100 mV	±34 µV	±45 µV	±46 µV
100 mV	1 kHz		100 mV	±70 µV	±90 µV	±100 µV
100 mV	50 kHz	Q		±150 µV	±160 µV	±170 µV
1 V	1 kHz		1 V	±600 µV	±800 µV	±900 µV
1 V	50 kHz			±1.4 mV	±1.6 mV	±1.7 mV
10 V	1 kHz		10 V	±6 mV	±8 mV	±9 mV
10 V	50 kHz	Q		±14 mV	±16 mV	±17 mV
10 V	10 Hz			±6 mV	±8 mV	±9 mV
100 V	1 kHz	Q	100 V	±60 mV	±80 mV	±90 mV
100 V	50 kHz			±140 mV	±160 mV	±170 mV
750 V	1 kHz		750 V	±450 mV	±600 mV	±675 mV
750 V [1]	50 kHz			±1.05 V	±1.2 V	±1.275 V

[1] Some calibrators may have difficulty driving the multimeter and cable load at this V-Hz output. Use short, low capacitance cable to reduce calibration loading. Verification can be performed at >195 Vrms. New test limits can be computed from the accuracy specification shown in chapter 1 for the actual test conditions used.

Q: Quick performance verification test points.

Caution The 50 kHz ac voltage test points may fail performance verification if the internal shields have been removed and reinstalled. See the “Gain Adjustment,” on page 79, for further information on how to recalibrate the ac voltage function.

AC Gain Verification Test (AC I)

Configuration: AC current
 6½ digit
 AC FILTER slow (MEAS MENU)

- 1 Make sure you have read “Test Considerations” on page 64.
- 2 Select each function and range in the order shown below. Compare measurement results to the appropriate test limits shown in the table. (Be certain to allow for appropriate source settling.)

Input (Front)	Input Frequency	HP 34401A Range	Error From Nominal		
			24 hour	90 day	1 year
1A	1 kHz	1A	±1.4 mA	±1.4 mA	±1.4 mA
2A	1 kHz	3A	±4.8 mA	±4.8 mA	±4.8 mA



Gain Verification Test (Frequency)

Configuration: Frequency
 6½ digit

- 1 Make sure you have read “Test Considerations” on page 64.
- 2 Select each function and range in the order shown below. Compare measurement results to the appropriate test limits shown in the table. (Be certain to allow for appropriate source settling.)

Input (Front)	Input Frequency	Quick Check	HP 34401A Range	Error From Nominal		
				24 hour	90 day	1 year
10 mV [1] 1 V	100 Hz 100 kHz	Q	100 mV 1 V	±0.06 Hz ±6 Hz	±0.1 Hz ±10 Hz	±0.1 Hz ±10 Hz

[1] Using a coaxial input cable.
Q: Quick performance verification test points.

Optional AC Performance Verification Tests

These tests are *not* intended to be performed with every calibration. They are provided as an aid for verifying additional instrument specifications. There are no adjustments for these tests; they are provided for performance verification only.

Configuration: AC volts
 6½ digit
 AC FILTER slow (MEAS MENU)

- 1 Make sure you have read “Test Considerations” on page 64.
- 2 Select each function and range in the order shown below. Compare measurement results to the appropriate test limits shown in the table. (Be certain to allow for appropriate source settling.)

Input (Front)	Input Frequency	HP 34401A Range	Error From Nominal		
			24 hour	90 day	1 year
1 V	20 Hz	1 V	±600 µV	±800 µV	±900 µV
1 V	1 kHz	1 V	±600 µV	±800 µV	±900 µV
1 V	20 kHz	1 V	±600 µV	±800 µV	±900 µV
1 V	50 kHz	1 V	±1.4 mV	±1.6 mV	±1.7 mV
1 V	100 kHz	1 V	±6.3 mV	±6.8 mV	±6.8 mV
1 V	300 kHz	1 V	±45 mV	±45 mV	±45 mV
10 V	1 kHz	10 V	±6 mV	±8 mV	±9 mV
1 V	1 kHz	10 V	±2.4 mV	±3.5 mV	±3.6 mV
100 mV	1 kHz	10 V	±12 mV	±13 mV	±13 mV

Calibration Security Code

This feature allows you to enter a security code (electronic key) to prevent accidental or unauthorized calibrations of the multimeter. When you first receive your multimeter, it is secured. Before you can adjust calibration constants you *must* unsecure the meter by entering the correct security code. See example 1 in chapter 3, “Menu Tutorial,” starting on page 53.

- The security code is set to “HP034401” when the multimeter is shipped from the factory. The security code is stored in *non-volatile* memory, and *does not* change when power has been off or after a remote interface reset.
- To secure the multimeter from the remote interface, the security code may contain up to 12 alphanumeric characters as shown below. The first character *must* be a letter, but the remaining characters can be letters or numbers. You do not have to use all 12 characters but the first character must always be a letter.

A _ _ _ _ _ _ _ _ _ _ _ _ _ _ (12 characters)

- To secure the multimeter from the remote interface so that it can be unsecured from the front panel, use the eight-character format shown below. The first two characters must be “HP” and the remaining characters must be numbers. Only the last six characters are recognized from the front panel, but all eight characters are required. (To unsecure the multimeter from the front panel, omit the “HP” and enter the remaining numbers as shown on the following pages.)

H P _ _ _ _ _ _ _ _ (8 characters)

If you forget your security code, you can disable the security feature by adding a jumper inside the multimeter, and then entering a new code. See the procedure on the following page for more information.

To Unsecure the Multimeter Without the Security Code

To unsecure the meter without the correct security code, follow the steps below. Chapter 9, "Schematics," contains the schematics associated with this procedure. See example 1 in chapter 3, "Menu Tutorial," starting on page 53, for an example of entering the security code. Also see "Electrostatic Discharge (ESD) Precautions" on page 114 before beginning this procedure.

- 1 Disconnect the power cord.
- 2 Disconnect *all* input connections (both front and rear terminals).
- 3 Remove the instrument cover. There are two rear panel screws and one screw on the bottom cover (see the mechanical disassembly drawing on page 9-3.)
- 4 Remove the internal metal shields, push the top shield to the side, and then lift out (see the mechanical disassembly drawing on page 9-3.)
- 5 Connect the power cord and turn on the multimeter.
Be careful not to touch the power line connections.
- 6 Apply a short between the two exposed metal pads on JM500 (located between U500 and U506). The exposed metal pads are outlined with a small rectangular silkscreen. (See the component locator drawing for the 34401-66501 Main PC Board on page 9-5.)
- 7 While maintaining the short, enter any valid unsecure code. The multimeter is now unsecured.
- 8 Remove the short at JM500.
- 9 Reassemble the multimeter.

Now you can enter a new security code. Be sure you take note of the new security code.

Calibration Count

The calibration count feature provides an independent “serialization” of your calibrations. You can determine the number of times that your multimeter has been calibrated. By monitoring the calibration count, you can determine whether an unauthorized calibration has been performed. Since the value increments by one for each calibration, a complete calibration increases the value by approximately 35 counts.

- The calibration count is stored in *non-volatile* memory and *does not* change when power has been off or after a remote interface reset. Your multimeter was calibrated before it left the factory. When you receive your multimeter, read the calibration count to determine its value.
- The calibration count increments up to a maximum of 32,767 after which it wraps around to 0. There is no way provided to program or reset the calibration count. It is an independent electronic calibration “serialization” value.

Calibration Message

You can use the calibration message feature to record calibration information about your multimeter. For example, you can store such information as the last calibration date, the next calibration due date, the multimeter’s serial number, or even the name and phone number of the person to contact for a new calibration.

You can record information in the calibration message only from the remote interface. You can read the message from either the front-panel menu or the remote interface.

- The calibration message may contain up to 40 characters. The multimeter can display up to 12 characters of the message on the front panel; any additional characters are truncated.
- The calibration message is stored in *non-volatile* memory, and *does not* change when power has been off or after a remote interface reset.

Calibration Procedures

Before beginning any adjustment procedures, the multimeter *must* be in the “UNSECURED” state. To unsecure the multimeter, see “Calibration Security Code” on page 73. Each adjustment should be followed by a performance verification check for added confidence. We recommend that you always adhere to the following general procedure.

- Make sure you have read “Test Considerations” on page 64.
- Unsecure the multimeter as outlined in “Calibration Security Code” on page 73.
- Perform the Zero Adjustment Procedure.
- Perform the Gain Adjustment Procedure.
- Perform the Verification Tests.
- Secure the multimeter.
- Note the new secure code and calibration count in your maintenance records for future reference.

Aborting a Calibration in Progress

Sometimes it may be necessary to abort a calibration after the procedure has already been initiated. You can abort a calibration at any time by pressing any front-panel key (except `[Shift]`). When performing a calibration from the remote interface, you can abort a calibration by issuing a remote interface device clear message or by pressing the front-panel LOCAL key. Pressing the front/rear switch during a calibration will also abort the calibration in progress.

Zero Adjustment

Each time you perform a zero adjustment, the multimeter stores a new set of offset correction constants for every measurement function and range. Separate offset correction constants are stored for the front and rear input terminals. The multimeter will sequence through all required functions and ranges automatically and store new zero offset calibration constants. All offset corrections are determined automatically. *You may not correct a single range or function without re-entering ALL zero offset correction constants automatically. This feature is intended to save calibration time and improve zero calibration consistency.*

Caution Never turn off the multimeter during Zero Adjustment. This may cause ALL calibration memory to be lost.

4

Zero Adjustment Procedure

The automatic zero adjustment procedure takes about 5 minutes to complete for each terminal set calibrated (front or rear terminal).

Follow the steps outlined below. Review “Test Considerations” on page 64 before beginning this test. Also see example 2 in chapter 3, “Menu Tutorial,” starting on page 55, for an example of how to initiate a zero calibration.

- 1 Select the DC V function and apply a 4-wire short (copper) across the **Input HI-LO** and **Sense HI-LO** terminals as shown below (front or rear terminal).

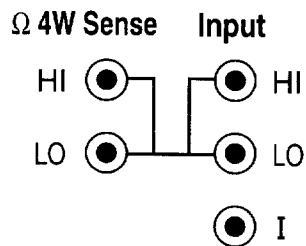

Zero Adjustment

Zero Adjustment

(continued)

- 2 Select the shorted terminal set (front or rear terminal) with the front/rear switch. *Separate calibration constants are stored for the front and rear input terminals.*
- 3 Turn on the menu () and then use or to select **F: CAL MENU**.
- 4 Use to move down to the “commands” level and select **2. CALIBRATE**.
- 5 Use to move down to the “parameters” level and then set the input value to *000.0000 mV*.
- 6 Execute the command by pressing .
ENTER
- 7 Perform the Zero Offset Verification tests (see page 67) to check zero calibration results .
- 8 Repeat steps 1 through 7 for the other input terminal set (front or rear terminal).

Gain Adjustment

The multimeter stores a *single* new gain correction constant each time this procedure is followed. The gain constant is computed from the calibration value entered for the calibration command and from measurements made automatically during the adjustment procedure.

Most measuring functions and ranges have gain adjustment procedures. Only the 100 M Ω range and the ac current, continuity, and diode test functions *do not* have gain calibration procedures. The gain calibration value may be entered through the front panel menu or over the remote interface. See example 2 in chapter 3, “Menu Tutorial,” starting on page 55, for an example of how to enter calibration values.

Adjustments for each function should be performed ONLY in the order shown in the performance verification table. See “Performance Verification Tests” earlier in this chapter for the tables used for gain adjustments.

Gain Adjustment Considerations

- The zero adjustment procedure *must* have been recently performed prior to beginning any gain adjustment procedures.
- The optional -10 Vdc, 500 Vdc, and 10 mA calibrations should be performed *only* after servicing the multimeter’s a-to-d converter or after replacing network U101 or calibration RAM U505. Refer to the “Optional Gain Calibration Procedures” section starting on page 82 for further details.
- When performing a 4-wire ohms gain adjustment, a new gain correction constant is *also stored* for the corresponding 2-wire ohms measurement range. If desired, the 2-wire gain can be adjusted separately *after* the 4-wire ohms gain calibration is completed.
- AC voltage gain calibration relies on a previous calibration of the dc voltage function. Failure to do so can cause significant calibration errors.

Never turn off the multimeter during a Gain Adjustment. This may cause calibration memory for the present function to be lost.

Gain Adjustment**Valid Gain Adjustment Input Values**

Gain adjustment can be accomplished using the following input values.

Function	Range	Valid Calibration Input Values
DC V	100 mV to 100 V 1000 V	0.9 to 1.1 x Full Scale 900 V to 1050 V
Ω 2W, Ω 4W	100 Ω to 10 M Ω	0.9 to 1.1 x Full Scale
DC I	10 mA to 1 A 3 A	0.9 to 1.1 x Full Scale 1 A to 3.03 A
AC V [1]	100 mV to 100 V 750 V	0.9 to 1.1 x Full Scale 195 V to 770 V
Frequency	Any	Any Input > 100 mV rms, 1 kHz – 100 kHz

[1] Valid frequencies are as follows: 1 kHz \pm 10% for the 1 kHz calibration, 45 kHz – 100 kHz for the 50 kHz calibration, and 10 Hz \pm 10% for the 10 Hz calibration.

Gain Adjustment Procedure

Adjustment for each function should be performed *only* in the order shown in the performance verification table. See “Performance Verification Tests,” starting on page 65, for the performance verification tables used for gain adjustments.

Review the “Test Considerations” (page 64) and “Gain Adjustment Considerations” (page 79) sections before beginning this test.

- 1 Select a function to be adjusted. Refer to the appropriate gain verification table (see pages 69 through 71).
- 2 Apply the input signal shown in the “Input” column of the appropriate verification table. *Always complete tests in the same order as shown in the appropriate verification table.*

Chapter 4 Calibration Procedures
Gain Adjustment

- 3 Turn on the menu (**Shift** **<**) and then use **<** or **>** to select **F: CAL MENU**.
- 4 Use **↓** to move down to the “commands” level and select **2. CALIBRATE**.
- 5 Use **↓** to move down to the “parameters” level and then set the calibration value for the present input value.
- 6 Execute the command by pressing **Auto/Man** .
ENTER
- 7 Perform the appropriate Gain Verification Test to check the calibration results.
- 8 Repeat steps 1 through 7 for each gain verification test point shown in the tables. *Each range in the gain adjustment procedure takes less than 20 seconds to complete.*

Optional Gain Calibration Procedures

The optional calibrations in this section are used to enhance the performance of your HP 34401A Multimeter. These calibrations are normally performed at the factory. These adjustments should be performed following the repair of your multimeter. You *are not* required to perform these adjustments at any other interval.

-10 Vdc Adjustment Procedure

The -10 Vdc calibration electronically corrects the multimeter's a-to-d converter linearity characteristic. *This adjustment should ONLY be performed after servicing the a-to-d converter or replacement of the calibration RAM (U505).*

Configuration: DC volts
6½ digit (slow resolution , NPLC 100 – MEAS MENU)

- 1** Perform the +10 V dc gain adjustment procedure. Note the multimeter's reading immediately following the +10 V calibration.
- 2** Manually reverse the multimeter's input connections and allow time for thermal offset voltages to settle (usually about 1 minute).
- 3** Enter the + 10 V reading noted in step 1 above with the “ - ” sign for the -10 V calibration value.
- 4** Check that the -10 V reversed input is within the following limits:
0 ± 30 µV of the +10 V input reading.

500 Vdc Adjustment Procedure

The 500 Vdc calibration electronically corrects the multimeter's 100:1 divider network (U101) linearity characteristic for minimum error. This adjustment should be performed *only* after replacement of the divider network U101 or the calibration RAM U505.

This calibration procedure is available starting with firmware Revision 3 (REV 03-01-01).

Inputs from 450 V to 550 V are valid for this procedure. A failure to complete this procedure correctly will generate error 725, "500V DC correction out of range".

Configuration: DC volts
1000 V range
6½ digit (slow or fast resolution – MEAS MENU)

- 1 Perform the complete dc Volts gain calibration procedure.
- 2 Apply +500 Vdc to the input terminals.
- 3 Enter the CALibration MENU as shown in steps 3 through 6 of the "Gain Adjustment Procedure" section on page 80. Enter the exact known value for the +500 Vdc input as shown in step 5.
- 4 Check that the multimeter reads within the following limits of the applied input after the calibration has completed: 0 ± 6 mVdc.

1/100th Scale AC Adjustment Procedure

This calibration procedure is used to enhance the ac volts and ac current measurement accuracy for <1/100th scale inputs. The single calibration generates a correction constant used for all ranges of the ac volts and ac current measuring functions. This adjustment should be performed after servicing ac section circuits or after replacement of the calibration RAM U505.

This calibration procedure is available starting with firmware Revision 2 (REV 02-01-01).

Inputs from 9 mA to 11 mA are valid for this procedure. A failure to complete this procedure correctly will generate error 736, “AC rms 100th scale linearity correction out of range”.

Configuration: AC current
1 A range
6½ digit (slow or fast resolution – MEAS MENU)
AC FILTER slow (MEAS MENU)

- 1 Perform the complete ac volts gain calibration procedure.
- 2 Apply 10 mA, 1 kHz ac to the current input terminals.
- 3 Enter the CALibration MENU as shown in steps 3 through 6 of the “Gain Adjustment Procedure” section on page 80. Enter the exact known value for the 10 mA ac input as shown in step 5.
- 4 Check that the multimeter reads within the following limits of the applied input after the calibration has completed: $0 \pm 400 \mu\text{A}$ ac.

Understanding the AC Signal Filter

The multimeter uses three different ac filters which enable you to either optimize low frequency accuracy or achieve faster ac settling times. The multimeter selects the *slow*, *medium*, or *fast* filter based on the input frequency that you specify.

Applies to ac voltage and ac current measurements only.

Input Frequency	AC Filter Selected	Settling Time
3 Hz to 300 kHz	Slow filter	7 seconds / reading
20 Hz to 300 kHz	Medium filter (default)	1 reading / second
200 Hz to 300 kHz	Fast filter	10 readings / second

- The ac filter selection is stored in *volatile* memory; the multimeter selects the *medium* filter (20 Hz) when power has been off or after a remote interface reset.
- *Front-Panel Operation:* Select from the menu the slow filter (3 Hz), medium filter (**20 Hz**), or fast filter (200 Hz). *The default is the medium filter.*

1: AC FILTER (**MEAS MENU**)

- *Remote Interface Operation:* Specify the lowest frequency expected in the input signal. The multimeter selects the appropriate filter based on the frequency you specify (see table above). The **CONF**igure and **MEAS**ure? commands select the 20 Hz filter.

DETEctor: BANDwidth {3|20|200|MINimum|MAXimum}

Understanding Resolution

Resolution is expressed in terms of *number of digits* the multimeter can measure or display. You can set the resolution to 4, 5, or 6 *full digits*, plus a “1/2” digit which can only be a “0” or “1”. To increase measurement accuracy and improve noise rejection, select 6^{1/2} digits. To increase measurement speed, select 4^{1/2} digits.

Applies to all measurement functions. The resolution for the math operations (null, min-max, dB, dBm, limit test) is the same as the resolution for the measurement function in use.

The correspondence between the number of digits selected and the resulting integration time (in *power line cycles*) is shown below. The autozero mode is set indirectly when you set the resolution.

Resolution Choices	Integration Time
Fast 4 Digit	0.02 PLC
* Slow 4 Digit	1 PLC
Fast 5 Digit	0.2 PLC
* Slow 5 Digit (<i>default</i>)	10 PLC
* Fast 6 Digit	10 PLC
Slow 6 Digit	100 PLC

* These settings configure the multimeter just as if you had pressed the corresponding “DIGITS” keys from the front panel.

Resolution is local to the selected function. This means that you can select the resolution for each function independently. The multimeter remembers the resolution when you switch between functions.

Chapter 4 Calibration Procedures

Understanding Resolution

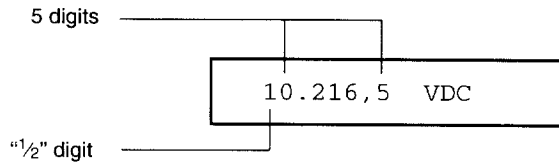

This is the 10 Vdc range, 5½ digits are displayed.

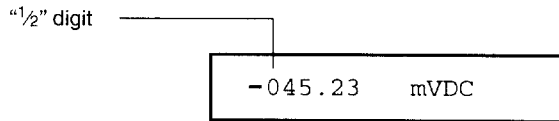

This is the 100 mVdc range, 4½ digits are displayed.

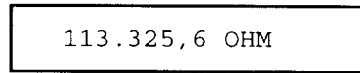

This is the 100 ohm range, 6½ digits are displayed.

- The resolution is stored in *volatile* memory; the multimeter sets the resolution to 5½ digits (for all functions) when power has been off or after a remote interface reset.
- The resolution is fixed at 5½ digits for continuity and diode tests.
- For dc and resistance measurements, changing the number of digits does more than just change the resolution of the multimeter. It also changes the *integration time*, which is the period the multimeter's analog-to-digital (A/D) converter samples the input signal for a measurement.
- For ac measurements, the resolution is actually fixed at 6½ digits. If you select 4½ digits or 5½ digits, the multimeter "masks" one or two digits. The only way to control the reading rate for ac measurements is by setting a trigger delay.
- For ratio measurements, the specified resolution applies to the signal connected to the **Input** terminals.

Resolution
(continued)

- *Front-Panel Operation:* Select either the slow or fast mode for each resolution setting. *The default mode is 5 digits slow.*

5: RESOLUTION (MEAS MENU)

See also "To Set the Resolution," on page 37.

- *Remote Interface Operation:* You can set the resolution using the following commands.

```
CONFigure:<function> {<range>|MIN|MAX|DEF}, {<resolution>|MIN|MAX|DEF}
MEASure:<function>? {<range>|MIN|MAX|DEF}, {<resolution>|MIN|MAX|DEF}
<function>:RESolution {<resolution>|MIN|MAX}
```

Specify the resolution in the same units as the measurement function, *not in number of digits*. For example, for dc volts, specify the resolution in volts. For frequency, specify the resolution in hertz.

```
CONF:VOLT:DC 10,0.001      4½ digits on the 10 Vdc range
MEAS:CURR:AC? 1,1E-6       6½ digits on the 1 A range
CONF:FREQ 1 KHZ,0.1 Hz    1000 Hz input, 0.1 Hz resolution
VOLT:AC:RES 0.05          50 mV resolution on the ac function
```

Error Messages

The following tables are abbreviated lists of multimeter's error messages. They are intended to include errors which are likely to be encountered during the procedures described in this chapter. For a more complete list of error messages and descriptions, see chapter 5 in the *HP 34401A User's Guide*.

System Error Messages

Error	Error Message
-330	Self-test failed
-350	Too many errors
501	Isolator UART framing error
502	Isolator UART overrun error
511	RS-232 framing error
512	RS-232 overrun error
513	RS-232 parity error
514	Command allowed only with RS-232
521	Input buffer overflow
522	Output buffer overflow
531	Insufficient memory
532	Cannot achieve requested resolution

Self-Test Error Messages

Error	Error Message
601	Front panel does not respond
602	RAM read/write failed
603	A/D sync stuck
604	A/D slope convergence failed
605	Cannot calibrate rundown gain
606	Rundown gain out of range
607	Rundown too noisy
608	Serial configuration readback failed
609	DC gain x1 failed
610	DC gain x10 failed
611	DC gain x100 failed
612	Ohms 500 nA source failed
613	Ohms 5 uA source failed
614	DC 1000 V zero failed
615	Ohms 10 uA source failed
616	DC current sense failed
617	Ohms 100 uA source failed
618	DC high voltage attenuator failed
619	Ohms 1 mA source failed
620	AC rms zero failed
621	AC rms full scale failed
622	Frequency counter failed
623	Cannot calibrate precharge
624	Unable to sense line frequency
625	I/O processor does not respond
626	I/O processor failed self-test

For further descriptions of the self-test procedures, refer to "Self-Test Procedures" in chapter 6.

Error Messages**Calibration Error Messages**

Error	Error Message
605	Cannot calibrate rundown gain
606	Rundown gain out of range
701	Cal security disabled by jumper
702	Cal secured
703	Invalid secure code
704	Secure code too long
705	Cal aborted
706	Cal value out of range
707	Cal signal measurement out of range
708	Cal signal frequency out of range
709	No cal for this function or range
720	Cal DCV offset out of range
721	Cal DCI offset out of range
722 [1]	Cal RES offset out of range
723 [1]	Cal FRES offset out of range
725 [2]	500V DC correction out of range
730	Precharge DAC convergence failed
731	A/D turnover correction out of range
732	AC flatness DAC convergence failed
733	AC low frequency convergence failed
734	AC low frequency correction out of range
735	AC rms converter noise correction out of range
736 [2]	AC rms 100th scale linearity correction out of range
740 [3]	Cal checksum failed, secure state
741 [3]	Cal checksum failed, string data
742 [3]	Cal checksum failed, DCV corrections
743 [3]	Cal checksum failed, DCI corrections
744 [3]	Cal checksum failed, RES corrections
745 [3]	Cal checksum failed, FRES corrections
746 [3]	Cal checksum failed, AC corrections
747 [3]	Cal checksum failed, HP-IB address
748 [3]	Cal checksum failed, internal data

[1] RES is the 2-wire ohms function. FRES is the 4-wire ohms function.

[2] Available starting with firmware Revision 2 (REV 02-01-01).

[3] This error may be generated if you turn off the power during a calibration. Recalibration is required to clear the error. If the error persists, a hardware failure of U505 may have occurred.

Theory of
Operation

Theory of Operation

This chapter is organized to provide descriptions of the circuitry contained on each schematic shown in chapter 9. A block diagram overview is provided in this chapter followed by more detailed descriptions of the circuitry contained in the schematics chapter.

- Block Diagram 93
- Front/Rear Selection 94
- Function Switching 95
- DC Amplifier 96
- Ohms Current Source 98
- AC Circuit 99
- A-to-D Converter 101
- Floating Logic 103
- Earth-Referenced Logic 105
- Power Supplies 106
- Front Panel 107

The self-test procedures are described in chapter 6.

Block Diagram

Referring to the block diagram on page 9-7, you will notice that the multimeter's circuitry is divided into two major blocks: the *floating circuitry* and the *earth (ground) referenced circuitry*. All measurement, control, and display functions are contained in the floating section. This section contains the input switching, function selection, and measurement circuitry. It also contains the multimeter's main CPU.

All measurement setup and a-to-d conversion is performed in the floating section. Each measuring function converts the input to a dc voltage between ± 12 volts. The ADC (a-to-d conversion) changes the dc voltage into a digital representation. This digital information is used by the main CPU to calculate the reading. Data stored at the time of calibration is recalled and used to correct the measurement data. The corrected reading is then formatted and sent to the front-panel processor for display. The corrected reading can also be sent to the earth referenced I/O processor for output to the remote interface.

The earth referenced circuitry consists of a processor configured as a slave to the main CPU. This processor establishes external I/O communications with the main CPU through an optically-isolated serial communication link. The earth referenced processor provides the HP-IB (IEEE-488) and RS-232 interfaces. It also handles external trigger and voltmeter complete handshake signaling.

Separate power supplies are provided for the floating and earth referenced sections. The front panel operates from the floating section with its logic common different from the floating CPU logic common.

Front/Rear Selection

Referring to the front/rear schematic on page 9-8, the purpose of this circuitry is to select either the front terminals or the rear terminals (via switch S1). The output of S1 is connected to the Function Switching schematic (see page 9-9). Input protection circuitry designed to protect the measuring circuits from high-energy transients such as electrostatic discharge or power-line transients is also shown.

The double fused (F101, F102) current input is designed to protect against potential catastrophic damage caused by accidental input connection across high VA sources beyond the 250 V rating of the rear-panel current input fuse. U110 bootstraps out the offset current errors caused by the leakage current of CR100. CR100 clamps the current input to protect R120 and R121 from excessive overloads.

Caution *Only the front panel or rear panel current input is fused with F101 and F102 as selected by the front/rear switch S1. The unselected input is not fused through F101 and F102.*

Function Switching

The purpose of the Function Switching section (schematic shown on page 9-9) is to connect the **Input HI** terminal to the various measuring functions. This is accomplished through K101, K102, K103, and K104. In addition, the connections of the 4-wire ohms **HI Sense** and **LO Sense** inputs are shown. Shunt selection (ranging) and voltage sensing are also shown for the current function. The table below shows the state of each relay for each measuring function. Relay K101 opens momentarily during each range or function change. All relay coils are driven from U150.

Function	K101	K102	K103	K104	Sense at:
0.1 V – 10 Vdc	Closed	Set	Set	Set [1]	U101-5
100 V – 1000 Vdc	Closed	Set	Reset	Set	U102-12
2-Wire Ohms	Closed	Reset	Set	Reset [2]	U101-5
4-Wire Ohms	Closed	Reset	Set	Reset [2]	[3]
AC Voltage	Closed	Set	Reset	Reset	AC_IN
Frequency/Period	Closed	Set	Reset	Reset	AC_IN
3 A, 1A DC I	Closed	Reset	Set	Reset	U101-10
100 mA, 10 mA DC I	Closed	Set	Set	Reset	U101-10
3A, 1A AC I	Closed	Reset	Set	Set	AC_IN

[1] K104 will be reset when input resistance is selected to >10,000 M Ω through the menu.

[2] K104 will be set for the 100 M Ω range.

[3] Configurations shown are for the current source output (HI) terminal. The measurement sense is accomplished through the Sense HI / Sense LO terminals.

DC Amplifier

The DC Amplifier circuit (schematic shown on page 9-10) is used by every measuring function except frequency and period. Analog switch U101B selects various input signals for measurement by the ADC. Switch U101B has three sources which can be dynamically selected: *measure customer input* (MC), *measure zero input* (MZ), and *precharge* (PRE). The MC state is the actual input measurement. The MZ state measures internal offset voltages which are also present in the MC measurement. The final measurement result is computed from MC-MZ. The PRE state is used to “precharge” internal capacitances to reduce charge injection to the input terminal from the dynamic switching of MC and MZ. Autozero off disables the dynamic switching of the amplifier input. However, a new MZ value is automatically taken whenever a new function or range is selected, even if autozero is turned off. [1]

In the dc voltage function, ranging is accomplished through both input relay switching (K101–K104) and solid state switching (U101). As a result, the input to the ADC has the same nominal 10V value for a full scale input on each range. The dc input op amp is comprised of source follower dual FET U104, amplifier U106, and associated bias circuitry. The feedback resistors U102C and switches U101C select non-inverting amplifier gains of x1, x10, and x100 for the dc input amplifier circuit. Amplifier output ADIN drives the dc input to the a-to-d converter for all measuring functions.

DCV Range	U102A Divider	U101 Input	Amplifier Gain	ADC Input
100 mV		Pin 5	x100	10 V
1 V		Pin 5	x10	10 V
10 V		Pin 5	x1	10 V
100 V	1/100	Pin 8	x10	10 V
1000 V	1/100	Pin 8	x1	10 V

[1] The output of the input amplifier will continue to cycle from a 0 V (MZ) level to the MC amplified input level during autozero operation. Autozero can be disabled from the remote interface or suspended using the TRIGGER SINGLE configuration from the front panel.

DC Amplifier

In the DC current function, a current is applied between the **Input I** and **LO** terminals. Ranging is accomplished by relay K102 and amplifier gain switching in U101. Since a known resistor (the shunt resistor) is connected between these terminals, a voltage proportional to the unknown current is generated. The voltage sensed at R121 is measured by the multimeter's dc circuitry. The table below illustrates the dc current measuring function configurations.

DCI Range	Shunt Resistor	U101-10 Input	Amplifier Gain	ADC Input
3A	0.1 Ω	300 mV	x10	3V
1A	0.1 Ω	100 mV	x100	10V
100 mA	5.1 Ω	510 mV	x10	5.1V
10 mA	5.1 Ω	51 mV	x100	5.1V

Resistance measurements are made by applying a known current through an unknown resistance. The resulting voltage drop across the unknown resistance is then measured by the multimeter's dc circuitry. The 100 M Ω range is measured using the known internal 10 M Ω resistance (U102A) in parallel with the unknown input resistance while applying the 500 nA current source. The result is computed from the measured data. The internal 10 M Ω resistance is determined whenever a zero calibration is performed.

In the 2-wire ohms function, the voltage drop is measured across the **Input HI** and **Input LO** terminals. In the 4-wire ohms function, the voltage is measured across the **HI Sense** and **LO Sense** terminals. Lead resistances in series with the current source (**Input HI-LO**) are not part of the final measurement. However, they do reduce the available current source compliance voltage for the resistor under test. The ohms current source will become non-linear when the compliance voltage limit is exceeded. The full scale voltage developed across the unknown resistor and the dc amplifier gain for each resistance range are tabulated below.

Ohms Range	Voltage Across R	Amplifier Gain	ADC Input
100 Ω	100 mV	x100	10 V
1 k Ω to 100 k Ω	1 V	x10	10 V
1 M Ω	5 V	x1	5 V
10 M Ω	5 V	x1	5 V
100 M Ω	4.5 V	x1	4.5 V

Ohms Current Source

The ohms current source (schematic shown on page 9-10) flows from the **Input HI** terminal to the **Input LO** terminal for both the 2-wire and 4-wire ohms functions. Each current value is generated by forcing a stable, precise voltage across a stable resistance. The value of the current becomes part of the range gain constant stored during calibration.

The +7 V reference voltage is used to generate a stable reference current with U201A. R201 and R202 are the resistance references for the current sources as shown in the table below. The IREF current is used to produce a precise voltage drop across the 28.57 k Ω resistor in U102D-4. The IREF generated using R202 produces an approximate 5 V drop across the 28.57 k Ω resistor. The IREF generated using R201 produces an approximate 0.5 V drop. This voltage is used to force a reference voltage across the selected current source range resistor (5 k Ω , 50 k Ω , 500 k Ω , 1 M Ω) by U201B. The resulting precision current flows through JFET Q202 and protection circuit Q203 to Q211, and CR202 to relay K102 where it is switched to the **Input HI** terminal for ohms measurements.

The protection circuits are designed to protect the ohms current source from inadvertently applied voltages in excess of ± 1000 V. Protection from large positive voltages is provided by the reverse breakdown voltage of CR202. Protection from large negative voltages is provided by the sum of the collector to base breakdown voltages of Q203, Q205, Q207, and Q209. Bias for these transistors is provided by Q211 and R203 to R206 while negative overvoltages are applied.

Ohms Range	Current	Open Circuit Voltage	Compliance Limit	Reference	Isource R U102D
100 Ω	1 mA	9 V	2.5 V	R202	5 k Ω
1 k Ω	1 mA	9 V	2.5 V	R202	5 k Ω
10 k Ω	100 μ A	9 V	4 V	R202	50 k Ω
100 k Ω	10 μ A	9 V	4 V	R202	500 k Ω
1 M Ω	5 μ A	9 V	8 V	R202	1 M Ω
10 M Ω	500 nA	14 V	10 V	R201	1 M Ω
100 M Ω [1]	500 nA [1]	5 V		R201	1 M Ω

[1] Measured in parallel with the internal 10 M Ω resistor.

AC Circuit

Referring to the schematic shown on page 9-11, the multimeter uses a true RMS ac-to-dc converter to measure ac voltages and currents. The ac-to-dc converter changes the input ac voltage to a dc voltage. All voltage ranging is performed in the ac circuit so that the input to the multimeter's dc circuitry (AC_OUT) is nominally 2 Vdc for a full scale ac input. The dc amplifier is always configured for x1 gain in ac functions (voltage, current, frequency, and period). Relay K104 connects the ac circuit to either the **Input HI** terminal or to R121, the current function voltage sense point. Note that the input to the ac circuit may contain a dc bias from the applied ac signal.

Input coupling capacitor C301 blocks the dc portion of the input signal. Only the ac component of the input signal is measured by the multimeter. The ac circuit voltage ranging comprises two gain stages U301 and U305/U312. The voltage gains for each stage are tabulated below.

Function	Range	1st Stage	2nd Stage	ADC Input
ACV, Freq, or Period	100 mV	x0.2	x100	2 Vdc
	1 V	x0.2	x10	2 Vdc
	10 V	x0.2	x1	2 Vdc
	100 V	x0.002	x10	2 Vdc
	700 V	x0.002	x1	1.4 Vdc
ACI	3 A	x0.2	x10	0.6 Vdc
	1 A	x0.2	x100	2 Vdc

The 1st stage is a compensated attenuator implementing a gain of x0.2 or x0.002 as selected by U304A and U304B. Each voltage range has a unique 50 kHz frequency response correction produced by a programmable variable capacitor connected across R304.

The programmable capacitance is implemented by varying the signal level across a compensating capacitor. In the x0.2 configuration, low frequency gain is set by R301, R302, and R304. The variable gain element U302/U303 essentially varies the value of C306 from 0 to 1 times its value in 256 steps. The exact gain constant is determined during the 50 kHz ac voltage range calibration procedure. In the x0.002 configuration, low frequency gain is set by R301, R302, and R303. The variable gain element U302/U303 essentially varies the value of C305 plus C306 from 0 to 1 times their value in 256 steps. The exact gain constant is determined during the 50 kHz ac voltage range calibration procedure.

The second stage is made up of two amplifiers (U305 and U312) each configured for a fixed gain of x10. Overall 2nd stage gains of x1, x10, and x100 are produced by routing the 1st stage output either around, or through one or both amplifiers as shown in the table below.

2nd Stage Gain	U306A	U306B	U306C	U306D	U304C
x1	ON	OFF	OFF	OFF	OFF
x10	OFF	ON	OFF	ON	OFF
x100	OFF	OFF	ON	ON	ON

The output of the 2nd stage is connected to the rms-to-dc converter stage. Any residual dc offset from the amplifier stages is blocked by capacitor C316. Buffer U307 drives the input to the rms-to-dc converter as well as the frequency comparator (U310A) input. The rms-to-dc converter has two selectable averaging filters (C318 and C318 plus C321) for the analog computer circuit of U308. The two analog averaging filters together with digital filters running in the main CPU implement the three selectable ac filters: slow, medium, and fast. The faster analog filter (using C318) is used for all AC V, AC I, and frequency or period autoranging. The slower analog filter is used only with the slow and medium ac filter choices.

In frequency or period measurements, U310A generates a logic signal (FREQIN) for every input zero crossing. The ac sections FREQRNG dc output is measured directly by the main CPU's 10-bit ADC during frequency or period measurements. This lower resolution measurement is sufficient to perform voltage ranging decisions for these functions. The frequency comparator output is disabled during ac voltage and current measurements by U310B forcing U310A's input to -15 volts.

A-to-D Converter

The analog-to-digital converter (ADC) is used to change dc voltages into digital information (schematic shown on page 9-12). The circuitry consists of an integrator amplifier (U402 and U420), current steering switch U411, resistor network U102E, voltage reference U403, ADC controller U501, and residue ADC U500.

The ADC method used by the HP 34401A is called *multislope III*. It is based on patented Hewlett-Packard ADC technology. Multislope III is a charge balancing continuously integrating analog-to-digital converter. The ADC charge balancing algorithm is always running, even when the multimeter is not triggered. The input voltage continuously forces charge onto the integrator capacitors C400 and C401 through U102E-R16.

Switches U411A and U411B steer fixed positive or negative reference currents onto the integrator capacitor to cancel, or balance, the accumulated input charge. The level shifted (R403 and R406) output of the integrator is checked every 2.66 μs by the U501 COMP input. Logic state machines in U501 control the U411 current steering to continuously seek an approximate 2.5 V level on the integrator amplifier output, FLASH. If the ADC input voltage ADIN is between ± 15 V, the integrator output (FLASH) will remain within the 0 V to 5 V range of the U500 on chip ADC. An input greater than +15 V may cause the integrator output (U402-6) to saturate at about -18 V. An input less than -15 V may cause U402 to saturate with an output of about +18 V. The U500 ADC input (FLASH) is clamped to 0 V or 5 V by R405 and CR403 to protect U500.

The integrator amplifier is formed by U402 and U420. Resistors R420 and R421 affect the amplifier stability. Amplifier oscillation may occur if their values are incorrect. Amplifier U420 improves the offset voltage characteristics of integrator amplifier U402.

Each analog-to-digital conversion begins when the multimeter is triggered. The ADC starts by clearing the integrator slope count in U501. At the end of the integration period, the slope count is latched. The slope count provides the most significant bits of the input voltage conversion. The least significant bits are converted by the on chip ADC of CPU U500.

The instrument precision voltage reference is U403. Resistor R409 provides a stable bias current for the reference zener diode. R408 and CR404 provide a bias to assure that the reference zener biases to +7 V during power up. IC U400A amplifies the voltage reference to +10 V while amplifier U401A inverts the +10 V reference to -10 V. The reference voltages force precision slope currents for the integrating ADC through U102E-R17, R18. Amplifier U401B provides a precise +5 V reference for the U500 on chip ADC.

Floating Logic

Referring to the schematic shown on page 9-13, the floating common logic controls operation of the entire instrument. All measurement control and bus command interpretation is performed in the main CPU, U500. The front panel and earth referenced processors operate as slaves to U500. The floating common logic is comprised of the main CPU U500, custom gate array U501, the program ROM U502, RAM U503, calibration EERAM U505, and the 12 MHz clock oscillator U405. Power-on reset is provided to the main CPU by voltage regulator U553.

The main CPU, U500, is a 16-bit micro controller incorporating such features as receive and transmit serial ports, timer/counter ports, an 8-bit pulse width modulated DAC port, and selectable input 10-bit successive approximation a-to-d converter ports. A conventional address/data bus is used to transfer data between the CPU and external ROM and RAM. When the address latch enable (ALE) signal goes high, address data is present on the address/data bus. Custom gate array U501 latches the address data and decodes the correct chip enable (low true) for external ROM and RAM accesses and for read/write accesses to the internal registers of U501. The system memory map is shown below.

0000H – 1FF7H	U503 8k x 8 RAM
1FF8H – 1FFFH	U501 Gate Array
2000H – FFFFH	U502 Program ROM

Program ROM U502 contains four 64k x 8 banks of data. Banks are selected by controlling the A16 and A17 ROM address bits directly from CPU port bits.

Custom gate array U501 performs address latching and memory map decoding functions as discussed above. In addition, U501 contains a variety of internal read/write registers. The read (XRD) and write (XWR) signals transfer data out of and in to U501 when it is addressed. There are four internal registers in U501: an internal configuration register, an 8 bit counter register, a serial transmit/receive register, and an internal status register.

The counter register is used to capture either ADC slope count at the COMP input or frequency count at the FREQIN input. The COMP input functions as both a clocked comparator and the slope counter input for the ADC. In both cases the counter register captures the lower 8 bits of a 24-bit counter. The upper 16 bits of the count are captured by the SYNC input to U500. The serial register is used to send and receive serial data bytes from the main CPU to the 40 bit (5 x 8 bits) measurement configuration register comprised of U309, U311, U150, and U101 or to communicate with the front panel processor. The serial register is multiplexed to these two circuits. The transmission rate is selected to 1.5 M bits/second for the measurement configuration registers and to 93.75 k bits/second for communication with the front panel processor. The general serial interface is a 3-bit interface as shown below.

U501 Internal Signal	Measurement Configuration Signals	Front Panel Signals
Serial Clock	SERCK	XFPSK
Data OUT (send)	SERDATO	FPDI
Data IN (receive)	SERRBK	FPDO

Serial data is received simultaneously as serial data is clocked out. The measurement configuration readback data (SERRBK) is only checked during self-test operation. Front panel data is exchanged in both directions whenever a byte is sent from U501. The measurement configuration register data is strobed to outputs by U500 signal SERSTB. Interrupts from the front panel are detected by U501 and signaled to the processor by CHINT. The processor line FPINT signals the front panel processor that U501 has data to send.

The gate array (U501) internal status register reports a serial port busy bit and 4 bits of time interpolation data. The time interpolation data is used to extend the time counting resolution of processor U500 during ADC conversions and frequency measurements.

The multimeter's calibration correction data are stored in a 128 x 16 bit non-volatile electrically erasable RAM, EERAM U505. The EERAM read/write data is accessed by a 4-bit serial protocol controlled by U500.

Earth-Referenced Logic

The main processor has an on chip 10-bit successive approximation ADC with two selectable inputs: FLASH and FREQRNG. The FLASH input is used to sample the residual charge on the main integrating ADC output of U402. The FREQRNG input is used to make voltage ranging decisions concurrent with frequency or period measurements.

The main CPU's pulse width modulated DAC outputs a 0 V to 5 V dc level after filtering the 23 kHz output with R507 and C512. This level is used to adjust the precharge amplifier offset voltage in U101. Port bits are also configured to detect the front/rear input switch position (FXR0) and to measure the input power line frequency (LSENSE). Frequencies from 55 Hz to 66 Hz are measured as 60 Hz. All other input frequencies are assumed to be 50 Hz.

The main CPU communicates with the earth referenced processor U700 through an optically isolated (U506 and U704) asynchronous serial link. Data is sent in an 11-bit frame at a rate of 187.5 k bits/second. When the RS-232 interface is selected, data is sent across the isolated link at 93.75 k bits/second. The 11-bit data frame is configured for one start bit, eight data bits, one control bit, and one stop bit.

Earth-Referenced Logic

The earth referenced logic circuits (schematic shown on page 9-14) provide all rear panel input/output capability. Microprocessor U700 handles HP-IB (IEEE-488) control through bus interface chip U701 and bus receiver/driver chips U702 and U703. The RS-232 interface is also controlled through U700. RS-232 transceiver chip U706 provides the required level shifting to approximate ± 9 volt logic levels through on-chip charge-pump power supplies using capacitors C708 and C709. Communication between the earth referenced logic interface circuits and the floating measurement logic is accomplished through an optically-isolated bi-directional serial interface. Isolator U506 couples data from U700 to microprocessor U501. Isolator U704 couples data from U501 to microprocessor U700.

Power Supplies

Referring to the schematic shown on page 9-15, the multimeter uses two types of power supplies: *floating supplies* and *earth referenced supplies*. The floating supply outputs are ± 18 Vdc, +5 Vdc, and a 5 Vrms center tapped filament supply for the vacuum fluorescent display. The earth referenced circuits are powered from a single +5 Vdc supply.

The ac mains are connected by module P1. This module includes the functions of mains connection, on/off switching, and line voltage selection (100/120/220/240). The multimeter automatically configures for the applied line frequency by counting the frequency of the output of clamp circuit CR554, R555, C555 (LSENSE).

The 5 volt floating supply is produced by bridge rectifier CR552, filter capacitor C556, and regulator U553. The reset output of U553 will change to logic LO when the unregulated dc input to the regulator falls below 5.5 volts. XPONRST is the instrument master hardware reset signal. This supply powers all floating logic. Relay drive circuits are also powered from this supply.

The floating ± 18 volt supplies are produced by bridge rectifier CR551, filter capacitors C551 and C553, and regulators U551 and U552. These supplies are used to power all measuring circuits. In addition, the vacuum fluorescent display is driven from the ± 18 volt supplies. A separate winding of T1 provides a center tapped 5 Vrms filament supply for the display. Bias circuit CR556, R556, and C559 generates the required cathode dc bias for the display filament supply.

The 5 volt earth referenced supply is produced by rectifier CR751, C752, and regulator U751. This supply is earth referenced by the screw which mounts the PC board to the instrument chassis. The HP-IB (IEEE-488) and RS-232 interfaces along with other input/output circuits are powered from this supply.

Front Panel

The front panel circuits (schematic shown on page 9-16) consist of vacuum fluorescent display control, display high voltage drivers, and keyboard scanning. Communication between the front panel and floating logic circuits is accomplished through a 4-wire bidirectional serial interface. The main CPU, U500, can cause a hardware reset to processor U600 by signal IGFPRES. The front panel logic operates from +13 volts (logic 0) and +18 volts (logic 1). The four serial communication signals are level shifted by comparator U602 from the floating logic 0 V to 5 V levels to the 13 V to 18 V levels present on the front panel assembly. The front panel logic low supply (+13 volts) is produced by the +18 volt supply and 4.7 V zener CR606. Level shift outputs for the front panel receive data are clamped to the 13 volt supply VLB.

Display anode and grid voltages are +18 volts for an “on” segment and -18 volts for an “off” segment. The -12 V cathode bias for the display is provided by filament winding center tap bias circuit CR556, R556, and C559 on the power supply schematic (see page 9-15). Keyboard scanning is accomplished through a conventional scanned row-column key matrix. Keys are scanned by outputting data to shift register U601 to poll each key column for a key press. Row read-back data are parallel loaded into shift register U601 and shifted back into processor U600 for decoding and communication to the floating logic circuits.



Service

Service

This chapter discusses the procedures involved for returning a failed multimeter to Hewlett-Packard for service or repair. Subjects covered include the following:

- Operating Checklist *111*
- Types of Service Available *112*
- Repackaging for Shipment *113*
- Electrostatic Discharge (ESD) Precautions *114*
- Surface Mount Repair *114*
- To Replace the Power-Line Fuse *114*
- To Replace the Current Input Fuses *115*
- To Connect the Pass/Fail Output Signals *115*
- Troubleshooting Hints *117*
- Self-Test Procedures *120*

Operating Checklist

Before returning your multimeter to Hewlett-Packard for service or repair, check the following items:

Is the multimeter inoperative?

- Verify that the ac power cord is connected to the multimeter.
- Verify that the front-panel Power switch is depressed.
- Verify that the power-line fuse is good.
- Verify the power-line voltage setting.

See "To Prepare the Multimeter for Use" on page 29.

Does the multimeter fail self-test?

- Verify that the correct power-line voltage is selected.

See "To Prepare the Multimeter for Use" on page 29.

- Remove all measurement connections to the multimeter.

Ensure that all measurement terminal connections (both front and rear terminals) are removed while the self-test is performed. Errors may be induced by ac signals present on the multimeter input terminals during self-test. Long test leads can act as an antenna causing pick-up of ac signals.

Is the multimeter's current input inoperative?

- Verify that the rear panel 3 A, 250 V current fuse is functional.
- Verify that the internal 7 A, 250 V high-interrupt fuse is functional.

See "To Replace the Current Input Fuses" on page 115.

Types of Service Available

If your multimeter fails within three years of original purchase, Hewlett-Packard will repair or replace it free of charge. If your unit fails after your three year warranty expires, HP will repair or replace it at a very competitive price. HP will make the decision locally whether to repair or replace your unit.

Standard Repair Service (Worldwide)

Contact your nearest HP Service Center. They will arrange to have your multimeter repaired or replaced.

Express Exchange Service (U.S. only)

You can receive a replacement HP 34401A via overnight shipment for short downtime.



1 Call 1-800-258-5165 and ask for “Express Exchange.”

- You will be asked for your shipping address and a credit card number to guarantee return of your failed multimeter.
- If you do not return your failed multimeter within 45 days, your credit card will be billed for a new HP 34401A.
- If you choose not to supply a credit card number, you will be asked to send your failed unit to a designated HP Service Center. After the failed unit is received, HP will send your replacement unit.

2 HP will immediately send a replacement HP 34401A to you via overnight shipment.

- The replacement unit will have a different serial number than your failed unit.
- If you can not accept a new serial number for the replacement unit, use the *Standard Repair Service* option described above.

Chapter 6 Service

Repackaging for Shipment

- If your failed unit was “in-warranty,” your replacement unit will continue the warranty time clock to the end of your three year standard warranty. You *will not* be billed for the replacement unit as long as the failed unit is received by HP.
- If your three year warranty has expired, HP will bill you for the HP 34401A exchange price — less than a new unit price. HP warrants exchange units against defects for 90 days.

Repackaging for Shipment

For the *Express Exchange Service* described on the previous page, return your failed HP 34401A to the designated HP Service Center using the shipping carton of the exchange unit. A shipping label will be supplied. HP will notify you when your failed unit has been received.

If the instrument is to be shipped to HP for service or repair, be sure to:

- Attach a tag to the multimeter identifying the owner and indicating the required service or repair. Include the instrument model number and full serial number.
- Place the multimeter in its original container with appropriate packaging material.
- Secure the container with strong tape or metal bands.

If the original shipping container is not available, place your unit in a container which will ensure at least 4 inches of compressible packaging material around all sides for the multimeter. Use static-free packaging materials to avoid additional damage to your unit.

Hewlett-Packard recommends that you always insure shipments.

Electrostatic Discharge (ESD) Precautions

Almost all electrical components can be damaged by electrostatic discharge (ESD) during handling. Component damage can occur at electrostatic discharge voltages as low as 50 volts.

The following guidelines will help prevent ESD damage when servicing the multimeter or any electronic device.

- Disassemble instruments *only* in a static-free work area.
- Use a conductive work area to dissipate static charge.
- Use a conductive wrist strap to dissipate static charge accumulation.
- Minimize handling.
- Keep replacement parts in original static-free packaging.
- Remove all plastic, styrofoam, vinyl, paper, and other static-generating materials from the immediate work area.
- Use *only* anti-static solder suckers.

Surface Mount Repair

Surface mount components should *only* be removed using soldering irons or desoldering stations *expressly* designed for surface mount components. *Use of conventional solder removal equipment will almost always result in permanent damage to the printed circuit board and will void your Hewlett-Packard factory warranty.*

To Replace the Power-Line Fuse

The power-line fuse is located within the multimeter's fuse-holder assembly on the rear panel (see page 31). For all power-line voltages, you must use a 250 mA slow-blow fuse (HP part number 2110-0817).

To Replace the Current Input Fuses

The front and rear current input terminals are protected by two series fuses. The first fuse is a 3 A, 250 Vac, fast-blow fuse and is located on the rear panel. To replace this fuse, order HP part number 2110-0780.

A second fuse is located inside the multimeter to provide an additional level of current protection. This fuse is a 7 A, 250 Vac, high-interrupt rated fuse (HP part number 2110-0614). To replace this fuse, you must remove the multimeter's case by loosening three screws (see the mechanical disassembly drawing on page 9-3).

To Connect the Pass/Fail Output Signals

The RS-232 connector on the multimeter's rear panel is a 9-pin connector (DB-9, male connector). When the RS-232 interface *is not* selected (IEEE-488 interface is selected), the internal pass and fail TTL output signals (limit testing) may be connected to the RS-232 connector. The pass and fail signals are low true and indicate the Math Pass/Fail Limit Test result for the *next* reading to be output to the HP-IB interface. The signals are active low for approximately 2 ms for each reading taken.

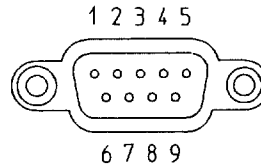

RS-232 Connector

Pin Number	Input/Output	Description
1	Output	* Limit Test Pass
2	Input	Receive Data (RxD)
3	Output	Transmit Data (TxD)
4	Output	Data Terminal Ready (DTR)
5	-	Signal Ground (SG)
6	Input	Data Set Ready (DSR)
9	Output	* Limit Test Fail

* TTL output is available only after installing two jumpers inside the multimeter.

Pass/Fail Output
(continued)

Installation Procedure

The assembly drawings and schematics are located in chapter 9, "Schematics."

- 1 Unscrew the two rear bezel captive screws (see the mechanical disassembly drawing on page 9-3).
- 2 Remove one screw from bottom cover (see the mechanical disassembly drawing on page 9-3).
- 3 Slide the metal cover off of the chassis (see the mechanical disassembly drawing on page 9-3).
- 4 Install JM710 and JM711 located adjacent to the power supply connector, P751. A bare wire may be used if a 0 ohm surface mount resistor is not available. (See the component locator diagram for the 34401-66501 Main PC Board on page 9-5.)
- 5 Reassemble the multimeter. Make sure to reinstall the bottom cover screw.

Do not use the RS-232 interface if you have configured the multimeter to output pass/fail signals on pins 1 and 9. Internal components on the interface circuitry may be damaged.

Troubleshooting Hints

This section provides a brief check list of common failures. Before troubleshooting or repairing the multimeter, make sure the failure is in the instrument rather than any external connections. Also make sure that the instrument is accurately calibrated. The multimeter's circuits allow troubleshooting and repair with basic equipment such as a 6½-digit multimeter and a 100 MHz oscilloscope.

Caution *This instrument contains CMOS integrated circuits which are susceptible to failure due to electrostatic discharge. Refer to the "Electrostatic Discharge (ESD) Precautions" section earlier in this chapter for further handling precautions.*

Unit is inoperative

- Verify that the ac power cord is connected to the multimeter.
- Verify that the front-panel Power switch is depressed.
- Verify that the power-line fuse is good.
- Verify the power-line voltage setting.

See "To Prepare the Multimeter for Use" on page 29.

Unit reports an error between 740 and 748

These errors may be produced if you accidentally turn off power to the unit during a calibration or while changing a non-volatile state of the instrument. Recalibration or resetting the state should clear the error. If the error persists, a hardware failure of U505 may have occurred.

Unit fails self-test

Verify that the correct power-line voltage setting is selected. Also, ensure that all measurement terminal connections (both front panel and rear terminals) are removed while the self-test is performed. Errors may be induced by ac signals present on the multimeter input terminals during self-test. Long test leads can act as an antenna causing pick-up of ac signals.

Troubleshooting Hints
(continued)

Current input is inoperative

- Verify that the rear panel 3 A, 250 V current fuse is functional.
- Verify that the internal 7 A, 250 V high-interrupt fuse is functional.

Power supply problems

Check that the input to the supply voltage regulator is at least 1 V greater than its output. Circuit failures can cause heavy supply loads which may pull down the regulator output voltage.

Some circuits produce their own local power supplies from the main supplies. Be sure to check that these local supplies are active. In particular, the ADC (analog-to-digital converter), ac, and front panel sections have local supplies. Always check that the power supplies are free of ac oscillations using an oscilloscope.

Failure of the analog voltage reference U403 will cause many self-test failures. Be certain that U403 is seated properly in its socket.

Check the main supply voltages as shown below.

Power Supply	Minimum	Maximum
+5 Ground Ref.	4.75 V	5.25 V
+5 Floating	4.75 V	5.25 V
+18 Floating	18.0 V	20.0 V
-18 Floating	-17.0 V	-19.1 V
+7REF Floating	6.45 V	7.35 V
+5REF Floating	4.75 V	5.25 V

Readings indicate OVERLOAD

An overload is caused when the gain and offset corrected reading result is greater than the full scale value (or less than the full scale value) for the present measuring function and range. This can be caused by incorrect calibration, saturated (railed) dc input amplifier, or by failure of the a-to-d converter. Overload can also be caused if the current source value is too large in the ohms function. In ac functions, overload will also be generated if the output of the rms-to-dc converter U308 is greater than 2 Vdc for sinewave inputs > 20 Hz.

Readings are inaccurate

Inaccurate readings are normally caused by either invalid calibration or by non-linear measuring circuits. If recalibration does not correct the inaccuracies, the amplifier or solid state switches may be causing measurement non-linearities. Non-linear operation of the ohms current source due to failure of Q202 to Q211 may cause reading inaccuracies in the ohms function. If the input to the ADC is shown to be linear, check the ± 10 V reference voltages. Check switch U411, U420, and U402 for proper operation.

Readings show excessive noise

Reading noise is usually caused by the dc input amplifier or the a-to-d converter circuitry. Remember that it is normal for the most sensitive measuring ranges to show more noise than the least sensitive ranges. Verify that the multimeter fails to meet its zero input specifications. Low frequency ac measurements will experience more noise than higher frequency inputs. Verify that the multimeter fails to meet ac specifications. Ensure that the correct ac filter is selected for the applied input signal frequency.

If calibration constants become corrupted, it is possible for the multimeter to generate noisy results without a hardware failure. Perform a new zero offset calibration and gain calibration before attempting to service the instrument.

Readings indicate zero with any input applied

A constant zero reading is normally caused when either the output of the dc input amplifier is stuck at a fixed level (like 0 volts) or when the a-to-d converter integrator amplifier U402 is stuck at a fixed level.

Self-Test Procedures

Power-On Self-Test

Each time the multimeter is powered on, a small set of self-tests are performed. These tests check that the minimum set of logic and measurement hardware are functioning properly. The power-on self-tests are listed below in the order they are executed. For a more complete description of each test, see the description in the following section, "Self-Test Descriptions" (see below).

- Test 701, checks that the calibration security disable jumper is removed.
- Self-test 624, determines the correct power-line frequency for the measurement section.
- Copy secured calibration constants from calibration ram U505 to working ram U503. *Errors 740 through 748 may be reported during this operation.*
- Self-test 625, establishes communication with the I/O processor U700.
- Self-test 601, establishes communication with the front panel U600.
- Self-test 603, checks that the ADC logic is functioning U501.
- Self-test 604, checks that the ADC analog hardware is functioning.
- Self-test 626, checks that U700 passed its self-test.

Self-Test Descriptions

This section provides a brief description for each internal self-test procedure including purpose, test setup, and failure criteria. Erroneous self-test failures may occur when the power line voltage is improperly set. Errors may also be produced by ac signals present on the multimeter input terminals (front or rear) during self-test. Long test leads can act as an antenna causing pick-up of ac signals.

Failing a self-test procedure indicates that parts of the multimeter are not functioning properly and need to be serviced. Passing self-test gives a better than 90% confidence that the HP 34401A hardware is operational. However, passing self-test does not guarantee that the multimeter will produce accurate results. Only performance verification can ensure the accuracy of measurement results.

Self-test procedures are numbered in the order in which they are executed. The order is designed to build confidence from a small kernel towards progressively more complex internal configurations.

Many individual self-test procedures may be executed from the front panel by selecting the desired test number from the parameter list of the TEST command (in the SYS MENU).

Note K101 is always open during self-test so that signals present on the input terminals are disconnected. However, ac signals may still feed through K101 causing self-test failures as mentioned earlier in this section.

- 601 Front panel does not respond** The main CPU U500 attempts to establish serial communications with the front panel processor U600. During this test, U600 turns on all display segments. Communication must function in both directions for this test to pass.
- 602 RAM read/write failed** This test writes and reads a 55_H and AA_H checker board pattern to each address of ram U503. Any incorrect readback will cause a test failure. This error is only readable from the remote interface.
- 603 A/D sync stuck** The main CPU issues an A/D sync pulse to U500-38 and to U501 where ADC slope counters are latched. A failure is detected when a sync interrupt is not recognized and a subsequent time-out occurs.
- 604 A/D slope convergence failed** The dc section is configured to the measure zero state (MZ) in the 10 V range. This test checks whether the ADC integrator produces nominally the same number of positive and negative slope decisions ($\pm 10\%$) during a 20 ms interval.
- 605 Cannot calibrate rundown gain** This test checks the nominal gain between the integrating ADC and the U500 onchip ADC. This error is reported if the procedure can not run to completion due to a hardware failure.
- 606 Rundown gain out of range** This test checks the nominal gain between the integrating ADC and the U500 onchip ADC. The nominal gain is checked to $\pm 10\%$ tolerance.

- 607** **Rundown too noisy** This test checks the gain repeatability between the integrating ADC and the U500 onchip ADC. The gain test (606), is performed eight times. Gain noise must be less than ± 64 lsb's of the U500 onchip ADC.
- 608** **Serial configuration readback failed** This test re-sends the last 5 byte serial configuration data for the measurement sections. The data is then clocked back into U501 and compared against the original 5 bytes sent. A failure occurs if the data do not match.
- 609** **DC gain x1 failed** This test configures for the 10 V dc range. The dc amplifier gain is set to x1. The measure customer (MC) input is selected to the internal TSENSE source which produces 0.6 volts. A 20 ms ADC measurement is performed and checked against a limit of $0.6 \text{ V} \pm 0.3 \text{ V}$.
- 610** **DC gain x10 failed** This test configures for the 1 V dc range. The dc amplifier gain is set to x10. The measure customer (MC) input is selected to the internal TSENSE source which produces 0.6 volts. A 20 ms ADC measurement is performed and checked against a limit of $0.6 \text{ V} \pm 0.3 \text{ V}$.
- 611** **DC gain x100 failed** This test configures for the 100 mV dc range. The dc amplifier gain is set to x100. The measure customer (MC) input is selected to the internal TSENSE source which produces 0.6 volts. A 20 ms ADC measurement is performed and checked for a +overload response.
- 612** **Ohms 500 nA source failed** This test configures to the 10 V dc range with the internal 10 M 100:1 divider U102A connected across the input. The 500 nA ohms current source is connected to produce a nominal 5 V signal. A 20 ms ADC measurement is performed and the result is checked against a limit of $5 \text{ V} \pm 1 \text{ V}$.
- 613** **Ohms 5 uA source failed** This test configures to the 10 V dc range with the internal 10 M 100:1 divider U102A connected across the input. The 5 μA ohms current source is connected. The compliance limit of the current source is measured. A 20 ms ADC measurement is performed and the result is checked against a limit of $7.5 \text{ V} \pm 3 \text{ V}$.
- 614** **DC 1000 V zero failed** This test configures to the 1000 V dc range with no input applied. A 20 ms ADC measurement is performed and the result is checked against a limit of $0 \text{ V} \pm 5 \text{ mV}$.

- 615** **Ohms 10 μ A source failed** This test configures to the 10 V dc range with the internal 10 M 100:1 divider U102A connected across the input. The 10 μ A ohms current source is connected. The compliance limit of the current source is measured. A 20 ms ADC measurement is performed and the result is checked against a limit of $7.5 \text{ V} \pm 3 \text{ V}$.
- 616** **DC current sense failed** This test configures to the 3 A dc range. A 20 ms ADC measurement is performed and the result is checked against a limit of $0 \text{ A} \pm 5 \text{ A}$. This test confirms that the dc current sense path is functional. The test limit is set wide because K101 does not open the current input during self-test. This test should catch a dc current sense failure without causing false failures when current inputs are applied during self-test.
- 617** **Ohms 100 μ A source failed** This test configures to the 10 V dc range with the internal 10 M 100:1 divider U102A connected across the input. The 100 μ A ohms current source is connected. The compliance limit of the current source is measured. A 20 ms ADC measurement is performed and the result is checked against a limit of $7.5 \text{ V} \pm 3 \text{ V}$.
- 618** **DC high voltage attenuator failed** This test configures to the 1000 V dc range. The 500 nA ohms current source is connected to produce a nominal 5 V signal. A 20 ms ADC measurement is performed and the result is checked against a limit of $5 \text{ V} \pm 1 \text{ V}$.
- 619** **Ohms 1 mA source failed** This test configures to the 10 V dc range with the internal 10 M 100:1 divider U102A connected across the input. The 1 mA ohms current source is connected. The compliance limit of the current source is measured. A 20 ms ADC measurement is performed and the result is checked against a limit of $7 \text{ V} \pm 3.5 \text{ V}$.
- 620** **AC rms zero failed** This test configures for the 100 mV ac range with the ac input grounded through K103. The internal residual noise of the ac section is measured and checked against a limit of -10 mV to 70 mV at the output of the rms-to-dc converter.
- 621** **AC rms full scale failed** This test configures for the 100 mV ac range. The 1 mA ohms current source is switched on to charge the ac input capacitor C301. This produces a pulse on the output of the rms-to-dc converter which is sampled 100 ms after the current is applied. A 20 ms A/D measurement is performed and checked against a limit of $10 \text{ V} \pm 8 \text{ V}$ into the ADC.

- 622** **Frequency counter failed** This test configures for the 100 mV ac range. This test immediately follows test 621. With C301 holding a charge from test 621 the ac input is now switched to ground with K103. This produces a positive pulse on the input to the frequency comparator U310A. While C301 discharges, the ENAB FREQ bit is toggled four times to produce a frequency input to the counter logic in U501. A failure occurs if the counter can not measure the frequency input.
- 623** **Cannot calibrate precharge** This test configures to the 100 V dc range with no input applied. The ADC is configured for 200 ms measurements. The U500 pulse width modulated (PWM) DAC output (C512) is set to about 4 volts. A reading is taken in with U101 in the MC state. A second reading is taken in the PRE state. The precharge amplifier voltage offset is calculated. The U500 DAC output is set to about 1.5 volts and the precharge offset is measured again. The gain of the offset adjustment is calculated. This test assures a precharge amplifier offset adjustment is achievable.
- 624** **Unable to sense line frequency** This test checks that the LSENSE logic input to U500 is toggling. If no logic input is detected, the instrument will assume 50 Hz line operation for all future measurements.
- 625** **I/O processor does not respond** This test checks that communications can be established between U500 and U700 through the optically isolated (U506 and U704) serial data link. Failure to establish communication in either direction will generate an error.
- 626** **I/O processor failed self-test** This test causes the earth referenced processor U700 to execute an internal, ram test. Failure will generate an error.



Replaceable Parts

Replaceable Parts

This section contains information for ordering replacement parts for your HP 34401A Multimeter. The parts lists are divided into the following groups.

- 34401-66501 Main PC Assembly (A1) *page 127*
- 34401-66512 Front-Panel Display PC Assembly (A2) *page 133*
- HP 34401A Mainframe Replaceable Parts *page 134*
- Manufacturer's List *page 135*

Parts are listed in the alphanumeric order according to their schematic reference designators. The parts lists include a brief description of the part with the applicable HP part number and manufacturer part number.

To Order Replaceable Parts

You can order replaceable parts from Hewlett-Packard using the HP part number or directly from the manufacturer using the manufacturer's part number. Note that not all parts listed in this chapter are available as field-replaceable parts. To order replaceable parts from HP, do the following:

- 1 Contact your nearest HP Sales Office or HP Service Center.
- 2 Identify parts by their HP part number shown in the replaceable parts lists.
- 3 Provide the instrument model number and serial number.

Backdating and Part Changes

Always refer to chapter 8, "Backdating," before attempting repair or before ordering replacement parts. Parts changes are documented in the backdating chapter.

Chapter 7 Replaceable Parts
34401-66501 – Main PC Assembly (A1)

■ **34401-66501 – Main PC Assembly (A1)**

Reference Designation	HP Part Number	Qty	Part Description	Mfr. Code	Mfr. Part Number
C100	0160-6839	1	Capacitor-Fxd 470 pF ±2% 630 V	28480	0160-6839
C101-C103	0160-6842	3	Capacitor-Fxd 220 pF ±2% 630 V	28480	0160-6842
C104	0160-6497	36	Capacitor-Fxd 0.1 uF ±10% 50 V	04222	12065C104KAT A
C105	0160-6731	3	Capacitor-Fxd 1000 pF ±10% 50 V	04222	12061C102KAT A
C106-C107	0160-5967	4	Capacitor-Fxd 100 pF ±5% 50 V	04222	08051A101JAT A
C108	0160-6736	7	Capacitor-Fxd 0.01 uF ±10% 50 V	04222	12061C103KAT A
C109	0160-8156	1	Capacitor-Fxd 0.01 uF ±20% 1 kV	56289	C023A102J103M S38-CDH
C110	0160-6497		Capacitor-Fxd 0.1 uF ±10% 50 V	04222	12065C104KAT A
C111	0160-5967		Capacitor-Fxd 100 pF ±5% 50 V	04222	08051A101JAT A
C113	0160-6497		Capacitor-Fxd 0.1 uF ±10% 50 V	04222	12065C104KAT A
C120	0160-6497		Capacitor-Fxd 0.1 uF ±10% 50 V	04222	12065C104KAT A
C150	0160-6497		Capacitor-Fxd 0.1 uF ±10% 50 V	04222	12065C104KAT A
C151	0160-6736		Capacitor-Fxd 0.01 uF ±10% 50 V	04222	12061C103KAT A
C152	0160-6731		Capacitor-Fxd 1000 pF ±10% 50 V	04222	12061C102KAT A
C210	0160-5954	4	Capacitor-Fxd 220 pF ±5% 50 V	04222	08051A221JAT A
C212	0160-6497		Capacitor-Fxd 0.1 uF ±10% 50 V	04222	12065C104KAT A
C301	0160-6778	1	Capacitor-Fxd 0.22 uF ±10% 400 V	14752	210BE224K
C302	0160-7605	1	Capacitor-Fxd 1.8 pF ±13.89% 1.5 kV	04222	MA30SA1R8CAA
C303	0160-6098	1	Capacitor-Fxd 680 pF ±5% 50 V	04222	12061A681JAT A
C304	0160-5973	1	Capacitor-Fxd 6.8 pF ±7.35% 50 V	04222	08051A6R8DAT A
C305	0160-6096	1	Capacitor-Fxd 470 pF ±5% 50 V	04222	12061A471JAT A
C306	0160-5972	1	Capacitor-Fxd 5.6 pF ±8.93% 50 V	04222	08051A5R6DAT A
C307	0160-5967		Capacitor-Fxd 100 pF ±5% 50 V	04222	08051A101JAT A
C308-C310	0160-6497		Capacitor-Fxd 0.1 uF ±10% 50 V	04222	12065C104KAT A
C311-C312	0180-4116	6	Capacitor-Fxd 22 uF ±20% 20 V	28480	0180-4116
C313	0160-5955	1	Capacitor-Fxd 68 pF ±5% 50 V	04222	08051A680JAT A
C314-C315	0160-6497		Capacitor-Fxd 0.1 uF ±10% 50 V	04222	12065C104KAT A
C316	0160-5892	2	Capacitor-Fxd .22 uF ±10% 63 V	28480	0160-5847
C317	0160-6729	2	Capacitor-Fxd 3300 pF ±10% 50 V	04222	12061C332KAT A
C318	0160-5892		Capacitor-Fxd 0.22 uF ±10% 63 V	28480	0160-5847
C319-C320	0160-6497		Capacitor-Fxd 0.1 uF ±10% 50 V	04222	12065C104KAT A
C322-C323	0180-4116		Capacitor-Fxd 22 uF ±20% 20 V	28480	0180-4116
C324	0160-5959	2	Capacitor-Fxd 33 pF ±5% 50 V	04222	08051A330JAT A
C326	0160-6731		Capacitor-Fxd 1000 pF ±10% 50 V	04222	12061C102KAT A
C327	0160-5959		Capacitor-Fxd 33 pF ±5% 50 V	04222	08051A330JAT A
C400-C402	0160-5954		Capacitor-Fxd 220 pF ±5% 50 V	04222	08051A221JAT A
C403-C404	0160-6497		Capacitor-Fxd 0.1 uF ±10% 50 V	04222	12065C104KAT A
C407-C410	0160-6497		Capacitor-Fxd 0.1 uF ±10% 50 V	04222	12065C104KAT A
C411	0180-3744	1	Capacitor-Fxd 4.7 uF ±20% 10 V	28480	0180-3744
C441-C442	0160-6736		Capacitor-Fxd 0.01 uF ±10% 50 V	04222	12061C103KAT A
C449	0160-6736		Capacitor-Fxd 0.01 uF ±10% 50 V	04222	12061C103KAT A
C500-C503	0160-6497		Capacitor-Fxd 0.1 uF ±10% 50 V	04222	12065C104KAT A
C504-C505	0160-6736		Capacitor-Fxd 0.01 uF ±10% 50 V	04222	12061C103KAT A

Chapter 7 Replaceable Parts
34401-66501 – Main PC Assembly (A1)

Reference Designation	HP Part Number	Qty	Part Description	Mfr. Code	Mfr. Part Number
C506	0160-6497		Capacitor-Fxd 0.1 uF ±10% 50 V	04222	12065C104KAT A
C512	0180-4228	2	Capacitor-Fxd 47 uF ±20% 10 V	28480	0180-4228
C551	0180-4433	2	Capacitor-Fxd 1000 uF ±20% 50 V	28480	0180-4433
C552	0180-3751	3	Capacitor-Fxd 1 uF ±20% 35 V	28480	0180-3751
C553	0180-4433		Capacitor-Fxd 1000 uF ±20% 50 V	28480	0180-4433
C554	0180-3751		Capacitor-Fxd 1 uF ±20% 35 V	28480	0180-3751
C555	0160-6497		Capacitor-Fxd 0.1 uF ±10% 50 V	04222	12065C104KAT A
C556	0180-4435	1	Capacitor-Fxd 2200 uF ±20% 25 V	28480	0180-4435
C557	0180-4116		Capacitor-Fxd 22 uF ±20% 20 V	28480	0180-4116
C558	0160-6497		Capacitor-Fxd 0.1 uF ±10% 50 V	04222	12065C104KAT A
C559	0180-4116		Capacitor-Fxd 22 uF ±20% 20 V	28480	0180-4116
C700-C703	0160-6497		Capacitor-Fxd 0.1 uF ±10% 50 V	04222	12065C104KAT A
C704	0160-6729		Capacitor-Fxd 3300 pF ±10% 50 V	04222	12061C332KAT A
C705	0160-6096		Capacitor-Fxd 470 pF 50 V	04222	08051A221JAT A
C706	0180-4228		Capacitor-Fxd 47 uF ±20% 10 V	28480	0180-4228
C707-C711	0160-6497		Capacitor-Fxd 0.1 uF ±10% 50 V	04222	12065C104KAT A
C751	0160-6497		Capacitor-Fxd 0.1 uF ±10% 50 V	04222	12065C104KAT A
C752	0180-4434	1	Capacitor-Fxd 4700 uF ±20% 25 V	28480	0180-4434
C753	0180-3751		Capacitor-Fxd 1 uF ±20% 35 V	28480	0180-3751
CR100	1901-0638	1	Diode-Full-Wave Bridge 100V 4A	71744	KBU4B
CR103	1902-1565	3	Diode-Zener 4.7V 5% TO-236	28480	1902-1565
CR201	1902-1565		Diode-Zener 4.7V 5% TO-236	28480	1902-1565
CR202	1901-1378	1	Diode-HV Rectifier 1.6KV 500 mA	71744	GP10Y
CR203	1902-1592		Diode-Zener 5.1V 5% TO-236	28480	1902-1565
CR302-CR303	1906-0291	10	Diode-Dual 70V 100 mA TO-236AA	04713	MBAV99
CR304-CR307	1902-1541	6	Diode-Zener 3.3V 5% TO-236	04713	BZX84C3V3
CR401-CR402	1902-1541		Diode-Zener 3.3V 5% TO-236	04713	BZX84C3V3
CR403-CR404	1906-0291		Diode-Dual 70V 100 mA TO-236AA	04713	MBAV99
CR551-CR552	1906-0407	3	Diode-Full-Wave Bridge 400V 1A	71744	DF04S
CR553	1906-0291		Diode-Dual 70V 100 mA TO-236AA	04713	MBAV99
CR554	1902-1542	1	Diode-Zener 6.2V 5% TO-236	04713	BZX84C6V2
CR555-CR556	1902-1609	2	Diode-Zener 6.2V 5% PD=1.5W	04713	1SMB5920B
CR701-CR705	1906-0291		Diode-Dual 70V 100 mA TO-236AA	04713	MBAV99
CR751	1906-0407		Diode-Full-Wave Bridge 400V 1A	71744	DF04S
E100-E101	1970-0212	2	Tube Electron Surge Arrestor 1500V/10A	28480	1970-0212
E700	9164-0173	1	Alarm-Audible 25 V	28480	9164-0173
F101	2110-0780	1	Fuse (metric) 3A 250V FE UL	75915	235003
F102	2110-0614	1	Fuse (inch) 7A 250V NTD FE UL	75915	314007
FC101	2110-0869	1	Fuseholder-Horizontal PC Mnt 6.3A 250V	28480	2110-0869
FC102	2110-0565	1	Fuseholder Cap 12A Max For UL	28480	2110-0565
J701	1252-2161	1	Connector-Rect 24-CKT 24-Contact	00779	554923-2
J702-J703	1250-1884	2	Connector-RF BNC Fem 50-Ohm	00779	227161-6

Chapter 7 Replaceable Parts
34401-66501 – Main PC Assembly (A1)

Reference Designation	HP Part Number	Qty	Part Description	Mfr. Code	Mfr. Part Number
J704	1252-2266	1	Connector-Rect D-Submin 9-Ckt 9-Contact	00779	748959-1
JM501	0699-1503	5	Resistor-Fxd 0 CWM	91637	CRCW1206000J
JM551-JM553	0699-1503		Resistor-Fxd 0 CWM	91637	CRCW1206000J
JM751	0699-1503		Resistor-Fxd 0 CWM	91637	CRCW1206000J
K101	0490-1914	1	Relay-Reed 2A 500 Vdc 5 Vdc-Coil	71707	3200-0121
K102-K104	0490-1789	3	Relay 2C 5 Vdc-Coil 3A 220 Vdc	28480	0490-1789
L101	9140-1244	2	Inductor-Fixed 1 mH $\pm 5\%$ 3.4W	28480	9140-1244
L102-L104	9140-1238	5	Inductor-Fixed 10 uH $\pm 5\%$ 2.8W	24226	SM3-102J
L106	9140-1244		Inductor-Fixed 1 mH $\pm 5\%$ 3.4W	28480	9140-1244
L110-L111	9140-1238		Inductor-Fixed 10 uH $\pm 5\%$ 2.8W	24226	SM3-102J
L401-L403	9170-1431	4	Core-Shielding Bead	28480	9170-1431
L404	9170-1506	1	Core-Shielding Bead	28480	9170-1506
L501	9170-1431		Core-Shielding Bead	28480	9170-1431
P101-P102	34401-62101	2	Input Jack Assy	28480	34401-62101
P500	1252-4484	1	Connector Post Type 12-Contact	27264	52007-1210
P551	1252-4488	1	Connector Post Type 8-Contact	27264	26-64-4080
P751	1252-4487	1	Connector Post Type 3-Contact	27264	26-64-4030
PCB1	34401-26501	1	Printed Circuit Board-Blank	28480	34401-26501
Q104	1855-0752	2	Transistor J-FET N-Chan D-Mode	27014	MMBF4392
Q150-Q153	1854-1014	4	Transistor NPN SI PD=350 mW Ft=100 MHz	04713	MMBT6429
Q201	1855-0752		Transistor J-FET N-Chan D-Mode	27014	MMBF4392
Q202	1855-0863	1	Transistor J-FET P-Chan D-Mode	27014	MMBF5461SEL
Q203-Q210	1853-0727	8	Transistor PNP SI SOT-23	04713	MMBT6520L
Q211	1855-0865	1	Transistor J-FET N-Chan D-Mode	27014	MMBF4117A
Q301	1855-0800	1	Transistor MOSFET N-Chan E-Mode	04713	MTD3055EL
R101-R102	0699-1327	3	Resistor 1M $\pm 1\%$.125W	28480	0699-1327
R103	0699-1380	5	Resistor 3.16K $\pm 1\%$.125W	28480	0699-1380
R104-R111	0699-3409	8	Resistor 13K $\pm 5\%$ 1W	91637	CRCW2512-133J
R112-R113	0699-1330	5	Resistor 100K $\pm 1\%$.125W	28480	0699-1330
R114-R117	0699-1423	17	Resistor 215 $\pm 1\%$.125W	28480	0699-1423
R118	0699-1380		Resistor 3.16K $\pm 1\%$.125W	28480	0699-1380
R119	0699-1423		Resistor 215 $\pm 1\%$.125W	28480	0699-1423
R120	0699-1514	1	Resistor .1 $\pm 1\%$ 5W MFS	01686	LO-5-.1-1-RP
R121	0699-3413	1	Resistor 5 $\pm 0.1\%$.125W	11502	CM60T13 5OHMS0.1
R122	0699-1329	4	Resistor 6.19K $\pm 1\%$.125W	28480	0699-1329
R124	0699-1329		Resistor 6.19K $\pm 1\%$.125W	28480	0699-1329
R126-R127	0699-1398	8	Resistor 21.5K $\pm 1\%$.125W	28480	0699-1398

7

Chapter 7 Replaceable Parts
34401-66501 – Main PC Assembly (A1)

Reference Designation	HP Part Number	Qty	Part Description	Mfr. Code	Mfr. Part Number
R130	0699-1394	2	Resistor 14.7K ±1% .125W	28480	0699-1394
R131	0699-1398		Resistor 21.5K ±1% .125W	28480	0699-1398
R150	0699-1391	9	Resistor 10K ±1% .125W	28480	0699-1391
R151	0699-1427	2	Resistor 316 ±1% .125W	28480	0699-1427
R160-R161	0686-4715	2	Resistor 470 ±5% .5W CC	01121	EB4715
R170-R176	0699-3406	14	Resistor 24K ±5% 1W	91637	CRCW2512-243J
R180-R186	0699-3406		Resistor 24K ±5% 1W	91637	CRCW2512-243J
R196	0699-1391		Resistor 10K ±1% .125W	28480	0699-1391
R197	0699-1389	3	Resistor 8.25K ±1% .125W	28480	0699-1389
R201	0699-3404	1	Resistor 400K ±1% .125W	28480	0699-3404
R202	0699-4416	1	Resistor 40K ±1% Radial	28480	0699-4416
R203-R206	0699-1332	4	Resistor 196K ±1% .125W	28480	0699-1332
R207	0699-1377	5	Resistor 2.37K ±1% .125W	28480	0699-1377
R290	0699-1374		Resistor 1.78K ±1% .125W	28480	0699-1374
R301-R302	0699-2469	2	Resistor 500K ±0.25% .25W	28480	0699-2469
R303	0699-1307	1	Resistor 1.96K ±0.1% .1W	28480	0699-1307
R304	0699-0481	1	Resistor 200K ±1% .1W	28480	0699-0481
R305	0699-1374		Resistor 1.78K ±1% .125W	28480	0699-1374
R306	0699-1423		Resistor 215 ±1% .125W	28480	0699-1423
R307	0699-1374		Resistor 1.78K ±1% .125W	28480	0699-1374
R308	0699-1423		Resistor 215 ±1% .125W	28480	0699-1423
R309	0699-1329		Resistor 6.19K ±1% .125W	28480	0699-1329
R310	0699-1360	1	Resistor 46.4 ±1% .125W	28480	0699-1360
R311-R312	0699-1412	3	Resistor 75K ±1% .125W	28480	0699-1412
R313	0699-1329		Resistor 6.19K ±1% .125W	28480	0699-1329
R314	0699-1398		Resistor 21.5K ±1% .125W	28480	0699-1398
R315	0699-1327		Resistor 1M ±1% .125W	28480	0699-1327
R316	0699-1423		Resistor 215 ±1% .125W	28480	0699-1423
R317	0699-1406	2	Resistor 42.2K ±1% .125W	28480	0699-1406
R318	0699-1318	12	Resistor 1K ±1% .125W	28480	0699-1318
R319	0699-1398		Resistor 21.5K ±1% .125W	28480	0699-1398
R320	0699-1427		Resistor 316 ±1% .125W	28480	0699-1427
R321	0699-1382	1	Resistor 3.83K ±1% .125W	28480	0699-1382
R322	0699-1412		Resistor 75K ±1% .125W	28480	0699-1412
R323-R324	0699-1398		Resistor 21.5K ±1% .125W	28480	0699-1398
R325-R326	0699-1423		Resistor 215 ±1% .125W	28480	0699-1423
R327	0699-1389		Resistor 8.25K ±1% .125W	28480	0699-1389
R403	0699-1399	1	Resistor 8.25K ±1% .125W	28480	0699-1319
R405	0699-1380		Resistor 3.16K ±1% .125W	28480	0699-1380
R406	0699-1330	6	Resistor 100 ±1% .125W	28480	0699-1415
R407-R408	0699-1318		Resistor 1K ±1% .125W	28480	0699-1318
R409	0699-1372	1	Resistor 1.47K ±1% .125W	28480	0699-1372
R420	0699-1389		Resistor 8.25K ±1% .125W	28480	0699-1389
R421	0699-1318		Resistor 1K ±1% .125W	28480	0699-1318
R422	0699-1360		Resistor 46.4 ±1% .125W	28480	0699-1360

Chapter 7 Replaceable Parts
34401-66501 – Main PC Assembly (A1)

Reference Designation	HP Part Number	Qty	Part Description	Mfr. Code	Mfr. Part Number
R430	0699-1503	1	Resistor Zero Ohm	28480	0699-1503
R440	0699-1406		Resistor 42.2K ±1% .125W	28480	0699-1406
R441	0699-1394		Resistor 14.7K ±1% .125W	28480	0699-1394
R442	0699-2127	1	Resistor 36.5K ±1% .125W	28480	0699-2127
R449	0699-1415	1	Resistor 100 ±1% .125W	28480	0699-1415
R501	0699-1318		Resistor 1K ±1% .125W	28480	0699-1318
R502	0699-1330		Resistor 100K ±1% .125W	28480	0699-1330
R503	0699-1423		Resistor 215 ±1% .125W	28480	0699-1423
R504	0699-1391		Resistor 10K ±1% .125W	28480	0699-1391
R505-R506	0699-1386	2	Resistor 5.62K ±1% .125W	28480	0699-1386
R507	0699-1391		Resistor 10K ±1% .125W	28480	0699-1391
R508-R509	0699-1318		Resistor 1K ±1% .125W	28480	0699-1318
R510-R511	0699-1391		Resistor 10K ±1% .125W	28480	0699-1391
R512-R517	0699-1423		Resistor 215 ±1% .125W	28480	0699-1423
R518	0699-1391		Resistor 10K ±1% .125W	28480	0699-1391
R551	0699-1424	2	Resistor 237 ±1% .125W	28480	0699-1424
R552	0699-2431	1	Resistor 3.32K ±1% .125W	28480	0699-2431
R553	0699-1424		Resistor 237 ±1% .125W	28480	0699-1424
R554	0699-1380		Resistor 3.16K ±1% .125W	28480	0699-1380
R555	0699-1406	1	Resistor 42.2K ±1% .125W	28480	0699-1406
R556	0699-1391		Resistor 10K ±1% .125W	28480	0699-1391
R701	0699-3408	1	Resistor 1K ±5% 1W	91637	CRCW2512-102J
R702	0699-1398		Resistor 21.5K ±1% .125W	28480	0699-1398
R703	0699-1391		Resistor 10K ±1% .125W	28480	0699-1391
R704	0699-1330		Resistor 100K ±1% .125W	28480	0699-1330
R705	0699-1318		Resistor 1K ±1% .125W	28480	0699-1318
R706	0699-3407	1	Resistor 100 ±5% 1W	91637	CRCW2512-101J
R707-R708	0699-1318		Resistor 1K ±1% .125W	28480	0699-1318
R709	0699-1380		Resistor 3.16K ±1% .125W	28480	0699-1380
R720	0699-1374		Resistor 1.78K ±1% .125W	28480	0699-1374
R750-R751	0699-1318		Resistor 1K ±1% .125W	28480	0699-1318
RV100-RV102	0837-0382	3	Diode-Varistor 1.1KV	28480	0837-0382
S1	3101-3162	1	Switch-Pushbutton .4A 25 VAC/VDC	71468	603296
U101	1SK6-0001	1	Switch Chip	28480	1SK6-0001
U102	1NB4-5035	1	Resistor Network	28480	1NB4-5035
U103	1826-2420	5	IC-OP Amp LP Dual 8-Pin	24355	AD706JR
U104	1855-0864	1	Transistor-JFET Dual	27014	NPDSU406
U105	1826-2558	3	IC-OP Amp WB Sgl 8-Pin	04713	MC34081BD
U106	1826-1925	2	IC-OP Amp Low-Noise Sgl 8-Pin	06665	OP-27GS
U110	1826-2558		IC-OP Amp WB Sgl 8-Pin	04713	MC34081BD
U150	1820-8937	1	IC Gate-Array CMOS	27014	SCX6B04AKP
U153	1826-2420		IC-OP Amp LP Dual 8-Pin	24355	AD706JR

7

Chapter 7 Replaceable Parts
34401-66501 – Main PC Assembly (A1)

Reference Designation	HP Part Number	Qty	Part Description	Mfr. Code	Mfr. Part Number
U201	1826-2420		IC-Op Amp LP Dual 8-Pin	24355	AD706JR
U301	1826-2436	1	IC-Op Amp Wideband 8-pin	27014	LF356M
U302	1826-2339	1	IC-Converter D/A 8-Bit CMOS	24355	AD7524JR
U303	1826-2437	3	IC-Op Amp Wideband 8-Pin	27014	LF357M
U304	1826-1985	1	IC Analog Switch 4 SPST 16-P-SOIC	17856	DG411DY
U305	1826-2437		IC-Op Amp Wideband 8-Pin	27014	LF357M
U306	1826-1609	1	IC-Analog Switch 4 SPST 16-P-SOIC	17856	DG211DY
U307	1826-2558		IC-Op Amp WB Sgl 8-Pin	04713	MC34081BD
U308	1826-2445	1	IC-Converter RMS/DC 16-P-SOIC MISC	24355	AD637JR
U309	1820-5790	2	IC-Shf-Rgstr CMOS/74HC Synchro	18324	74HC4094D
U310	1826-1572	1	IC-Comparator PRCN Dual 8-Pin	18324	LM393D
U311	1820-5790		IC-Shf-Rgstr CMOS/74HC Synchro	18324	74HC4094D
U312	1826-2437		IC-Op Amp Wideband 8-Pin	27014	LF357M
U400-U401	1826-2420		IC-Op Amp LP Dual 8-Pin	24355	AD706JR
U402	1826-1991	1	IC-Op Amp HS Single 8-Pin	24355	AD711JR
U403	1826-1249	1	IC-V Rgltr-V-Ref-Fxd 6.8/7.1V	28480	1826-1249
U404	1820-5937	1	IC-FF CMOS/74AC D-Type Pos-Edge-Trig	27014	74AC74SC
U405	1813-0827	1	Clock-Oscillator-XTAL 12.0MHZ 0.01%	28480	1813-0827
U411	1820-4346	1	IC Muxr/Data-Sel CMOS/74HC 2-to-1-Line	18324	74HC4053D
U420	1826-1925		IC-Op Amp Low-Noise Sgl 8-Pin	06665	OP-27GS
U500	1820-1479	1	IC-MCU Embedded 80C196 PLCC68S	34649	N80C196KB
U501	1820-8907	1	IC Gate-Array CMOS	27014	SCX6206AK0
U502	34401-88861	1	Prog EPROM (1818-5187)	28480	34401-88861
(See above)	1818-5187	1	IC 2M OTP ROM 150-ns CMOS	34335	AM27C020-155JC
U503	1818-4777	1	IC CMOS 262144 (256K) STAT RAM 70-ns	28480	1818-4777
U505	1818-5236	1	IC 4K EEPROM 500-ns CMOS2	7014N	M93C66M8
U506	1990-1552	2	Opto-Isolator LED-IC Gate IF=10 mA-Max	28480	HCPL-2211-300
U551	1826-2465	1	IC V Rgltr-Adj-Pos 1.2/37V	27014	LM317T-LB01
U552	1826-2463	1	IC V Rgltr-Adj-Neg 1.2/37V	27014	LM337T-LB01
U553	1826-2461	1	IC V Rgltr-Fxd-Pos 4.75/5.25V	27014	LM2925T-LB01
U700	34401-88842	1	Micro Proc (1821-0015)	28480	34401-88842
(See above)	1821-0015	1	IC-8-Bit MCU w/8K EPROM & Prgmbl Cntr	34649	N87C51FA
U701	1820-6974	1	IC-GPIB Controller IEEE-488 1975/78	01295	TMS9914AFNL
U702	1820-6176	1	IC-Interface HPIB Octal Data XCVR	01295	SN75ALS160DW
U703	1820-6175	1	IC-Interface XCVR Bipolar Bus Octl	01295	SN75ALS162DW
U704	1990-1552		Opto-Isolator LED-IC Gate	28480	HCPL-2211-300
U705	1820-6470	1	IC-Schmitt-Trigger CMOS/74HCT	18324	74HCT14D
U706	1820-7662	1	IC-Interface Drvr/Rcvr Bipolar Dual	28480	1820-7662
U751	1826-2464	1	IC V Rgltr-Fxd-Pos 4.8/5.2V	27014	LM340T-5-LB01
US403	1200-1672	1	Socket-IC-DIP 4 Contact Dip-Sldr	06776	SBL-041-SP122-TG30
XF102	2110-0690	1	Fuseholder-Bipin-Socket 16A 250V UL	28480	2110-0690
Y701	0410-4009	1	Crystal-Quartz 12.0 MHz	28480	0410-4009

Chapter 7 Replaceable Parts
34401-66512 – Display Assembly (A2)

■ **34401-66512 – Display Assembly (A2)**

Reference Designation	HP Part Number	Qty	Part Description	Mfr. Code	Mfr. Part Number
C602	0160-5945	3	Capacitor-Fxd 0.01uF 50 V	04222	08055C103KAT A
C603-C605	0160-6497	10	Capacitor-Fxd 0.1uF 25 V	04222	12065C104KAT A
C606-C607	0160-5947	2	Capacitor-Fxd 100OpF 50 V	04222	08055C102KAT A
C608-C609	0160-5945		Capacitor-Fxd 0.01uF 50 V	04222	08055C103KAT A
C610-C615	0160-6497		Capacitor-Fxd 0.1uF 25 V	04222	12065C104KAT A
C616-C617	0180-3751	2	Capacitor-Fxd 1uF 35 V TA	S0545	NRS105M35R8
C618	0160-6497		Capacitor-Fxd 0.1uF 25 V	04222	12065C104KAT A
CR601	1906-0291	1	Diode-70V 100MA	04713	BAV99LT1
CR603	1902-1542	1	Diode-Zener 6.2V 5%	04713	BZX84C6V2
L601	9170-1431	1	Core-Shielding Bead	6352	HF50ACB-453215
M600*	33120-00611	1	Shield-ESD	28480	33120-00611
PCB1	34401-26512	1	Printed Circuit Board - Blank	28480	34401-26512
Q601	1854-1037	1	Transistor NPN SI TO-236AA PD=350MW	04713	MMBT3904LT1
R601	0699-1391	6	Resistor 10K ±1% .125W TKF TC=0±100	2M627	MCR18-F-X-1002
R602	0699-1399	2	Resistor 23.7K 1%	2M627	MCR18-F-X-2372
R603-R604	0699-1391		Resistor 10K ±1% .125W TKF TC=0±100	2M627	MCR18-F-X-1002
R605-R608	0699-1423	4	Resistor 215 ±1% .125W TKF TC=0±100	2M627	MCR18-F-X-2150
R609-R610	0699-1391		Resistor 10K ±1% .125W TKF TC=0±100	2M627	MCR18-F-X-1002
R611-R612	0699-1330	2	Resistor 100K ±1% .125W TKF TC=0±100	2M627	MCR18-F-X-1003
R613	0699-1399		Resistor 23.7K 1%	2M627	MCR18-F-X-2372
R614-R617	0699-1344	4	Resistor 10 ±1% .125W TKF TC=0±100	2M627	MCR18-F-X-10R0
R618	0699-1378	1	Resistor 2.61K 1%	2M627	MCR18-F-X-2611
R619	0699-1391		Resistor 10K ±1% .125W TKF TC=0±100	2M627	MCR18-F-X-1002
U601	1826-2264	1	IC-Power Management	04713	MC34064D-5
U602	34401-88813	1	Programmed 1820-8905 8-Bit MCU	28480	34401-88813
U603	1820-5330	1	IC-75518 Interface Driver, Bipolar	01295	SN75518FN
U604	1820-5562	1	IC-MC74HC02AD	01295	SN74HC02D
U605	1820-4966	1	IC-MC74HC74AD	01295	SN74HC74D
U606	2090-0296	1	Display - Vacuum Fluorescent	11908	CP3033A
U607	1826-1528	1	IC 339 Comparator	27014	LM339M
U608	1820-6756	1	74HC299-Shift Register 8 Bit Parallel	04713	MC74HC299D
U609	1826-1402	1	IC-Voltage Regulator 4.8/5.2V	04713	MC78L05ACD
W601	34401-61602	1	Cable Assembly, 8.8L	28480	34401-61602
Y601	0410-4009	1	Crystal 12MHz +1-0.8%	00830	PBRC-12.0BRN07

* M600 is shipped as a single part which breaks apart into two shields; you will use only one half of the part.

7

Chapter 7 Replaceable Parts
HP 34401A Mainframe

■ **HP 34401A Mainframe**

Reference Designation	HP Part Number	Qty	Part Description	Mfr. Code	Mfr. Part Number
A1	34401-66501	1	Main PC Assembly	28480	34401-66501
A2	34401-66512	1	Front-Panel and Display PC Assembly	28480	34401-66512
CVR1	34401-84101	1	Instrument Cover	28480	34401-84101
FRM1	34401-80101	1	Chassis	28480	34401-80101
KIT1	5180-6661	1	Standard Test Lead Kit	28480	5180-6661
KIT2*	34401-80010	1	Fuse Kit	28480	34401-80010
MNL1	34401-90100	1	English Manual Set (User's & Service)	28480	34401-90100
MP1	03478-88304	1	Rear Panel	28480	03478-88304
MP2	34401-40201	1	Front Panel/Bezel Assembly	28480	34401-40201
MP3	34401-43701	1	Power-On Push Rod	28480	34401-43701
MP4	34401-43702	1	Front/Rear Terminal Push Rod	28480	34401-43702
MP5	34401-45001	1	Carrying Handle	28480	34401-45001
MP6-MP7	34401-45002	2	Terminal Latch	28480	34401-45002
MP8	34401-49301	1	Window-Front-Panel Display	28480	34401-49301
MP9	34401-81902	1	Flubber Keys-Front Panel	28480	34401-81902
MP10*	34401-86201	1	Power Module/Fuse Drawer and Fuse	28480	34401-86201
MP11-MP12	34401-86000	2	Bumpers (Front/Rear) & Power Mod Cvr	28480	34401-86000
SCW1-SCW8	0515-0433	8	Screw-M4 X 0.7 8mm-Lg Pan-Hd	28480	0515-0433
SHD1	34401-00603	1	Shield-Top	28480	34401-00603
SHD2	34401-00602	1	Shield-Bottom	28480	34401-00602
T901	9100-4972	1	Transformer-Power	28480	9100-4972
Exchange Unit	34401-69201	1	Rebuilt HP 34401A Unit for Exchange	28480	34401-69201

* For serial numbers prior to 3146A31949, use a 125 mA fuse (p/n 2110-0894) for 220 or 240 Vac operation; for all other serial numbers, use a 250 mA fuse (p/n 2110-0817) for all line voltages.

Chapter 7 Replaceable Parts
Manufacturer's List

■ **Manufacturer's List**

Mfr. Code	Manufacturer's Name	Manufacturer's Address	Zip Code
00779	AMP Inc	Harrisburg, PA U.S.A.	17111
01121	Allen-Bradley Co Inc	El Paso, TX U.S.A.	79935
01295	Texas Instruments Inc	Dallas, TX U.S.A.	75265
01686	RCL Electronics Inc	Northbrook, IL U.S.A.	60062
04222	AVX Corp	Great Neck, NY U.S.A.	11021
04713	Motorola Inc	Roselle, IL U.S.A.	60195
06352	TDK Corporation of America	Skokie, IL U.S.A.	60076
06665	Precision Monolithics Inc	Santa Clara, CA U.S.A.	95054
06776	Robinson Nugent Inc	New Albany, IN U.S.A.	47150
09922	Burndy Corp	Norwalk, CT U.S.A.	06856
11502	IRC Inc	Boone, NC U.S.A.	28607
14752	Electro Cube Inc	San Gabriel, CA U.S.A.	91776
16428	Cooper Industries Inc	Houston, TX U.S.A.	77210
17856	Siliconix Inc	Santa Clara, CA U.S.A.	95054
18324	Signetics Corp	Sunnyvale, CA U.S.A.	94086
24226	Gowanda Electronics Corp	Gowanda, NY U.S.A.	14070
24355	Analog Devices Inc	Norwood, MA U.S.A.	02062
27014	National Semiconductor Corp	Santa Clara, CA U.S.A.	95052
27264	Molex Inc	Lisle, IL U.S.A.	60532
28480	Hewlett-Packard Company – Corporate	Palo Alto, CA U.S.A.	94304
34335	Advanced Micro Devices Inc	Sunnyvale, CA U.S.A.	94086
34649	INTEL Corp	Santa Clara, CA U.S.A.	95054
50088	SGS-Thomson Microelectronics Inc	Phoenix, AZ U.S.A.	85022
56289	Sprague Electric Co	Lexington, MA U.S.A.	02173
71468	ITT Corp	New York, NY U.S.A.	10022
71707	COTO Wabash	Providence, RI U.S.A.	02907
71744	General Instrument Corp	Clifton, NJ U.S.A.	07012
75915	Littelfuse Inc	Des Plaines, IL U.S.A.	60016
76381	3M Co	St. Paul, MN U.S.A.	55144
85480	Brady W H Co	Milwaukee, WI U.S.A.	53209
91637	Dale Electronics Inc	Columbus, NE U.S.A.	68601
2M627	Rohm Corporation	Kyoto 615, Japan	
S0545	NEC Electronics Inc	Mountain View, CA U.S.A.	94043

7



Backdating



Backdating

The table below lists all HP 34401A changes with prior serial numbers. This information is provided for backdating purposes only.

Approx. Effected Serial Numbers	Delete or Modify Part	Reference Designation	HP Part Number	Part Description	Effected Schematic
From 3146A64641 and Below	Modify Modify	A1U700 A1U502	34401-88842 34401-88861	IC-PRGMD Programmed EPROM	None None
From 3146A59641 and Below (See Note 1)	Delete Add	A2 A2	34401-66512 34401-66502	Display PC Assembly Display PC Assembly	Pg 9-5, 9-16 Pg 9-5, 9-16
From 3146A57986 and Below	Modify	A1C109	0150-0012	Capacitor .01uF 1kV	None
From 3146A54259 to 3146A37782	Modify Modify	A1U700 A1U502	34401-88832 34401-88851	IC-PRGMD Programmed EPROM	None None
From 3146A37781 to 3146A22602	Modify	A1U502	34401-88841	Programmed EPROM	None
From 3146A30500 and Below	Modify Modify	A1R207 A1CR203	0699-1386 1902-1565	Resistor 5.62K \pm 1% Diode-Zener 4.7V	None None
From 3146A26599 and Below	Modify Modify Modify	A1Y701 A2JM600 A2JM601	0410-2356 34401-00611 34401-00611	Crystal-Quartz 12.0 MHz Shield-ESD Shield-ESD	None None None
From 3146A23999 and Below (See Note 2) [Rev A 34401-66501]	Delete Modify Modify Delete Delete Delete Delete Modify Delete Modify Modify Modify	A1C111 A1C316 A1C318 A1C402 A1JM501 A1R327 A1R403 A1R422 A1R430 A1U102 A1U500	0160-5967 0160-5847 0160-5847 0160-5954 0699-1503 0699-1398 0699-1319 0699-1360 0699-1348 34401-67901 1820-6721	Capacitor-Fxd 100 pF \pm 5% Capacitor-Fxd 22 uF \pm 10% Capacitor-Fxd 22 uF \pm 10% Capacitor-Fxd 220 pF \pm 5% 50V Resistor Zero Ohms Resistor 21.5K \pm 1% .125W Resistor 12.1K \pm 1% Resistor 46.4K \pm 1% .125W Resistor 14.7 ohm \pm 1% Custom Resistor Network IC - 16 bit MCU	None None None None None None Pg 9-12 None Pg 9-12 None None None None
From 3146A22601 to 3146A06790	Modify	A1U502	34401-88823	Programmed EPROM	None
From 3146A06789 to 3146A03336	Modify	A1U502	34401-88821	Programmed EPROM	None
From 3146A03335 and Below	Modify	A1U502	34401-8881	Programmed EPROM	None

Note 1: The 34401-66502 parts list, component locator, and schematic are included on the following pages.

- Note 2:**
- Remove C111 from pin 4 of U101B and ground on the schematic on page 9-9.
 - Remove R327 from the schematic on page 9-11 and reconnect net directly to pin 15 of U304D.
 - Remove C402 from pin 2 of U402 and ground on the schematic on page 9-12.
 - Remove R422 from the schematic on page 9-12.
 - Remove JM501 from the schematic on page 9-13 and connect pin 26 to pin 1 of U503.

Chapter 8 Backdating
HP 34401A Multimeter

34401-66502 Display Assembly Replaceable Parts List

Reference Designation	HP Part Number	Qty	Part Description	Mfr. Code	Mfr. Part Number
C600-C601	0160-6497	4	Capacitor-Fxd 0.1 uF ±10% 50 V	04222	12065C104KAT A
C602-C604	0180-3751	3	Capacitor-Fxd 1 uF ±20% 35 V	28480	0180-3751
C605	0160-6736	3	Capacitor-Fxd 0.01 uF ±10% 50 V	04222	12061C103KAT A
C608-C609	0160-6497		Capacitor-Fxd 0.1 uF ±10% 50 V	04222	12065C104KAT A
C620-C621	0160-6731	2	Capacitor-Fxd 1000 pF ±10% 50 V	04222	12061C102KAT A
C622-C623	0160-6736		Capacitor-Fxd 0.01 uF ±10% 50 V	04222	12061C103KAT A
CR600	1902-1544	1	Diode-Zener 10V 5% TO-236 Pd=.35W	04713	BZX84C10
CR601	1906-0291	2	Diode-Dual 70V 100 mA	04713	MBAV99
CR603	1906-0291		Diode-Dual 70V 100 mA	04713	MBAV99
CR604-CR605	1906-0337	4	Diode-Dual 60V 200 mA2	84801	906-0337
CR606	1902-1565	1	Diode-Zener 4.7V 5%	28480	1902-1565
CR608-CR609	1906-0337		Diode-Dual 60V 200 mA	28480	1906-0337
M600*	33120-00611	1	Shield-ESD	28480	33120-00611
PCB1	34401-26502	1	Printed Circuit Board - Blank	28480	34401-26502
R600	0699-1322	1	Resistor 68.1K ±1% .125W	28480	0699-1322
R602	0699-1378	1	Resistor 2.61K ±1% .125W	28480	0699-1378
R603	0699-1399	1	Resistor 23.7K ±1% .125W	28480	0699-1399
R604	0699-1398	1	Resistor 21.5K ±1% .125W	28480	0699-1398
R605-R606	0699-1330	6	Resistor 100K ±1% .125W	28480	0699-1330
R609-R611	0699-1396	3	Resistor 17.8K ±1% .125W	28480	0699-1396
R620-R623	0699-1423	4	Resistor 215 ±1% .125W	28480	0699-1423
R640-R641	0699-1330		Resistor 100K ±1% .125W	28480	0699-1330
R643-R644	0699-1330		Resistor 100K ±1% .125W	28480	0699-1330
RP601	1810-1360	1	Network-Res 16-SMD 10.0K Ohm x 8	91637	SOMC-1603-103G
U600	1820-8985	1	IC-MCU w/FIP Driver	28480	1820-8985
U601	1820-5805	1	IC-Shf-Rgtsr CMOS/74HC Bidir	01295	SN74HC194DW
U602	1826-1528	1	IC-Comparator LP Quad	27014	LM339M
U603	2090-0296	1	Display-Vacuum Fluorescent	28480	2090-0296
W601	34401-61602	1	Cable Assy 8.8"L 0.236/0.157" Strip	28480	34401-61602

* M600 is shipped as a single part which breaks apart into two shields; you will use only one half of the part.

34401-66502 Display Assembly Component Locator

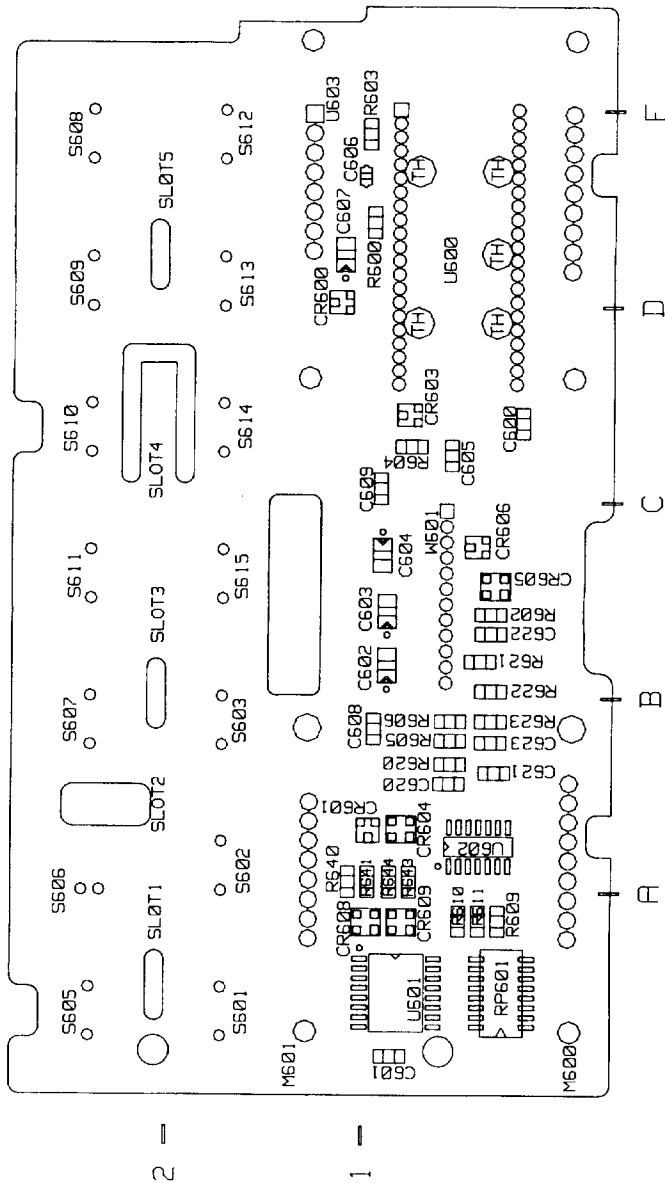

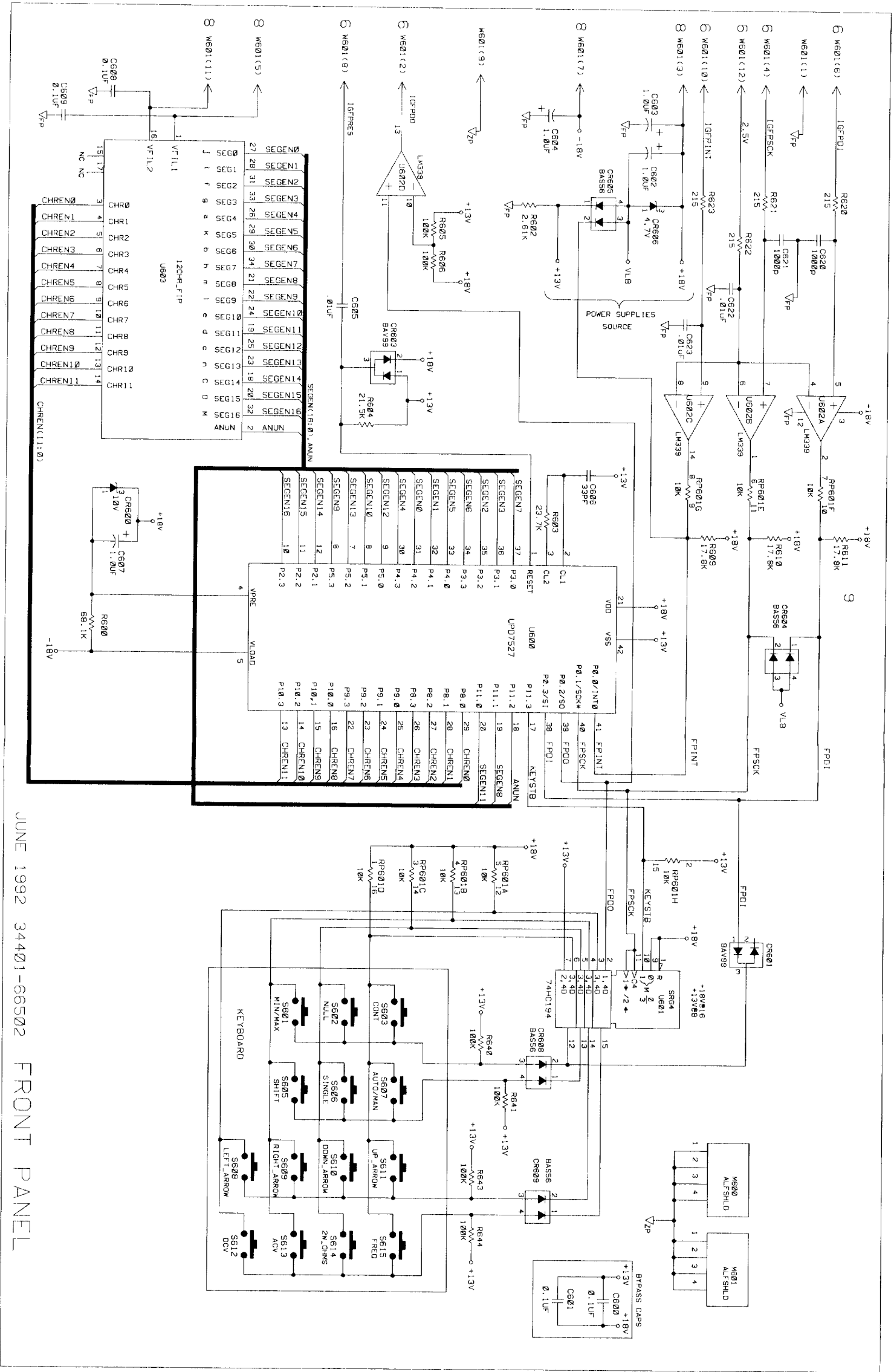

JUNE 1992 34401-66502 FRONT PANEL

34401-66502 Schematic
141



Schematics

Schematics

- Mechanical Disassembly *9-3*
- Component Locator Diagram – Main Board (34401-66501) *9-5*
- Component Locator Diagram – Front Panel (34401-66512) *9-6*
- HP 34401A Block Diagram *9-7*
- Front/Rear Selection Schematic *9-8*
- Function Switching Schematic *9-9*
- DC Amplifier and Ohms Schematic *9-10*
- AC Circuit Schematic *9-11*
- A/D Converter Schematic *9-12*
- Floating Logic Schematic *9-13*
- Earth-Referenced Logic Schematic *9-14*
- Power Supplies Schematic *9-15*
- Front-Panel Display Schematic *9-16*

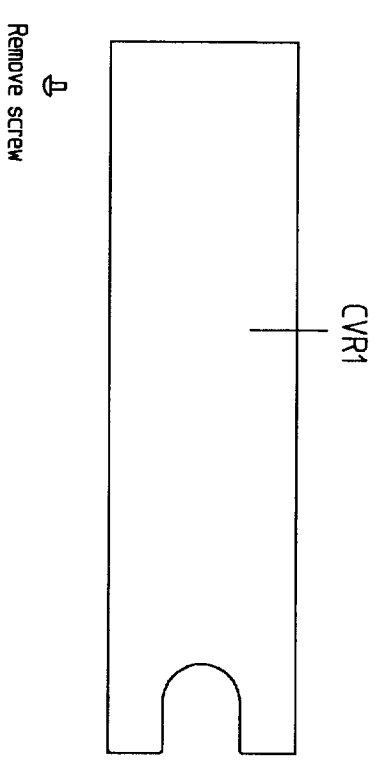
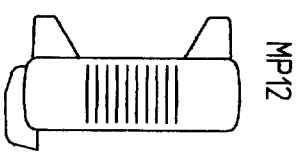

Basic Disassembly

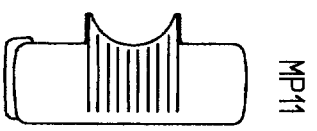
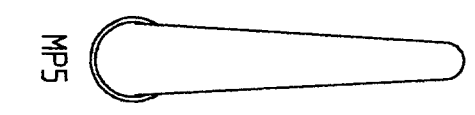
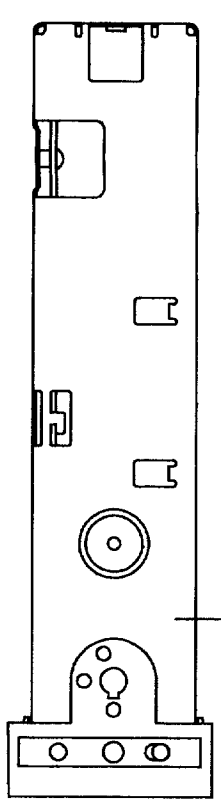

Removal of Shields

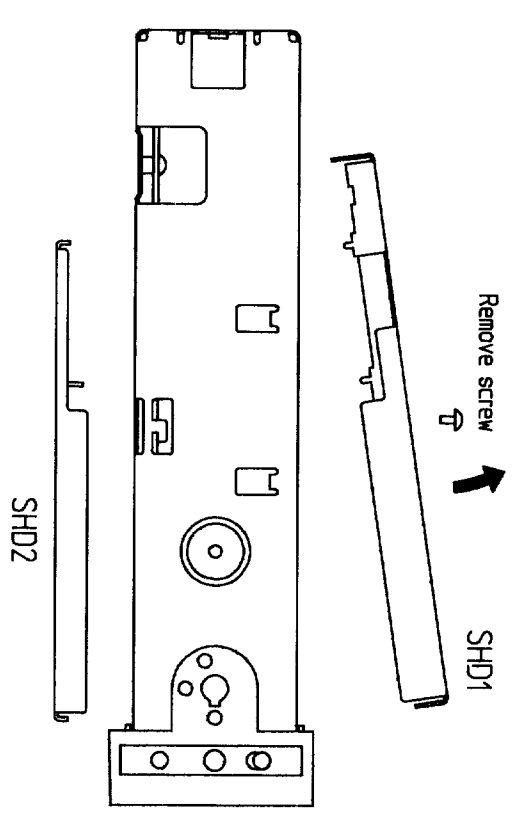

Transformer wire to Power Module connections

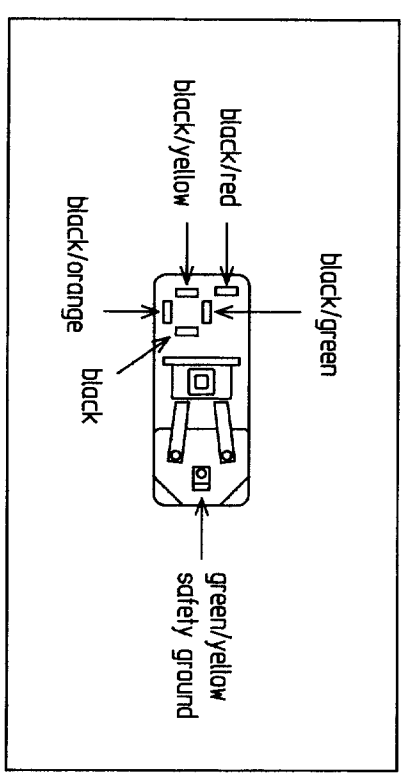

Mechanical Disassembly

Removal of Front Panel

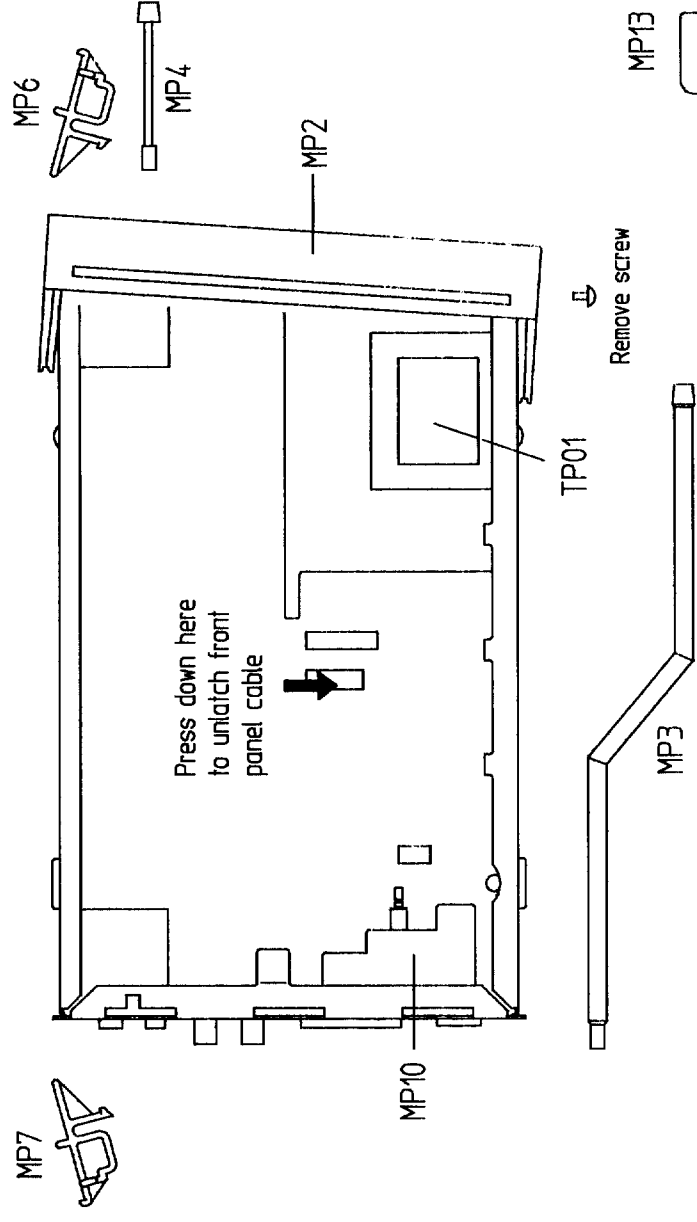

Disassembly of Front Panel

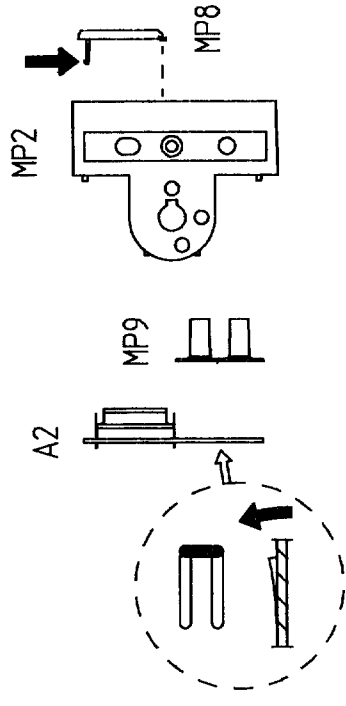

Removal of PC Assembly from Chassis

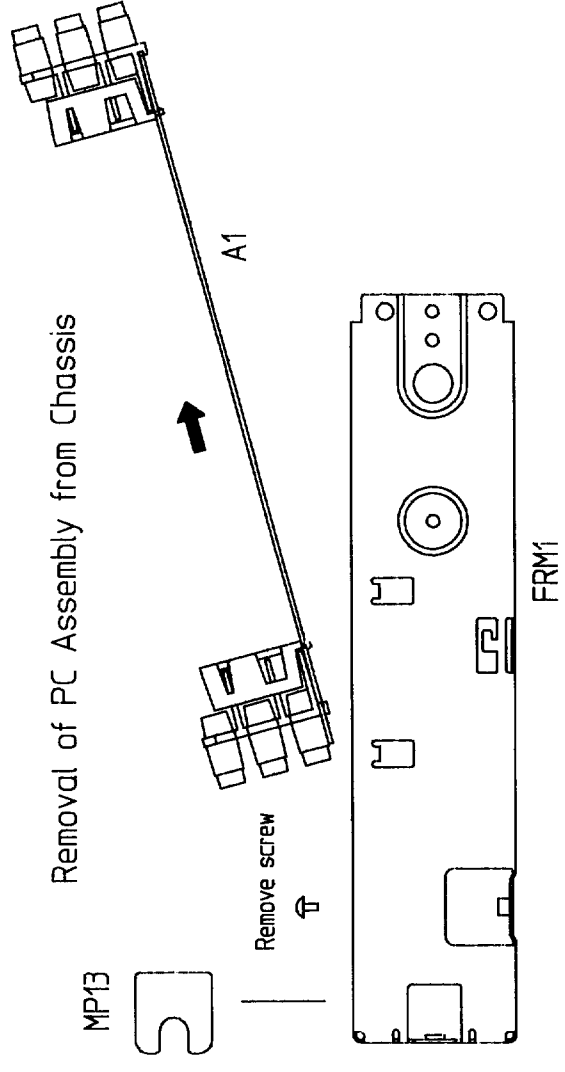

Mechanical Disassembly

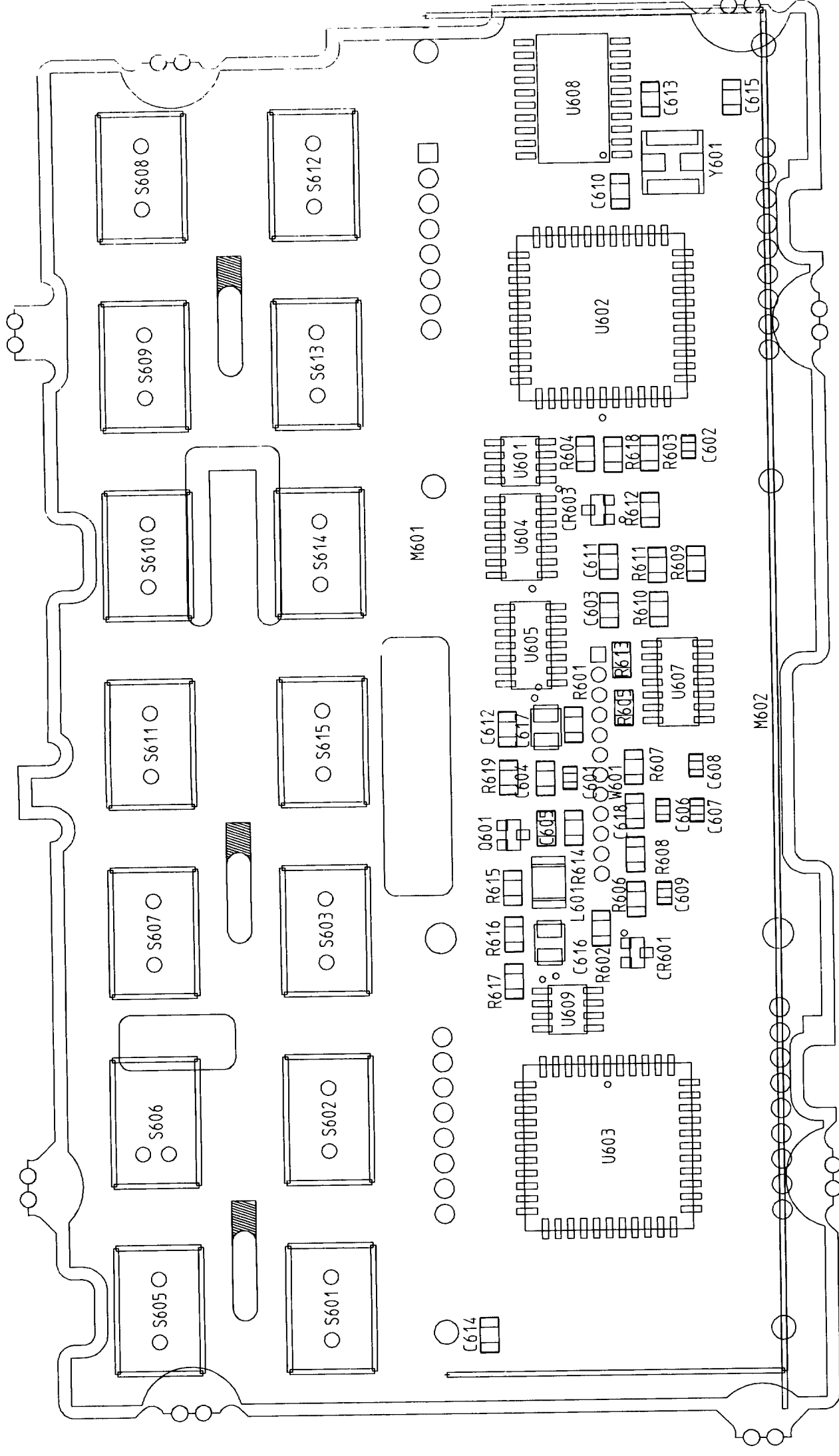

34401-66512 REV A

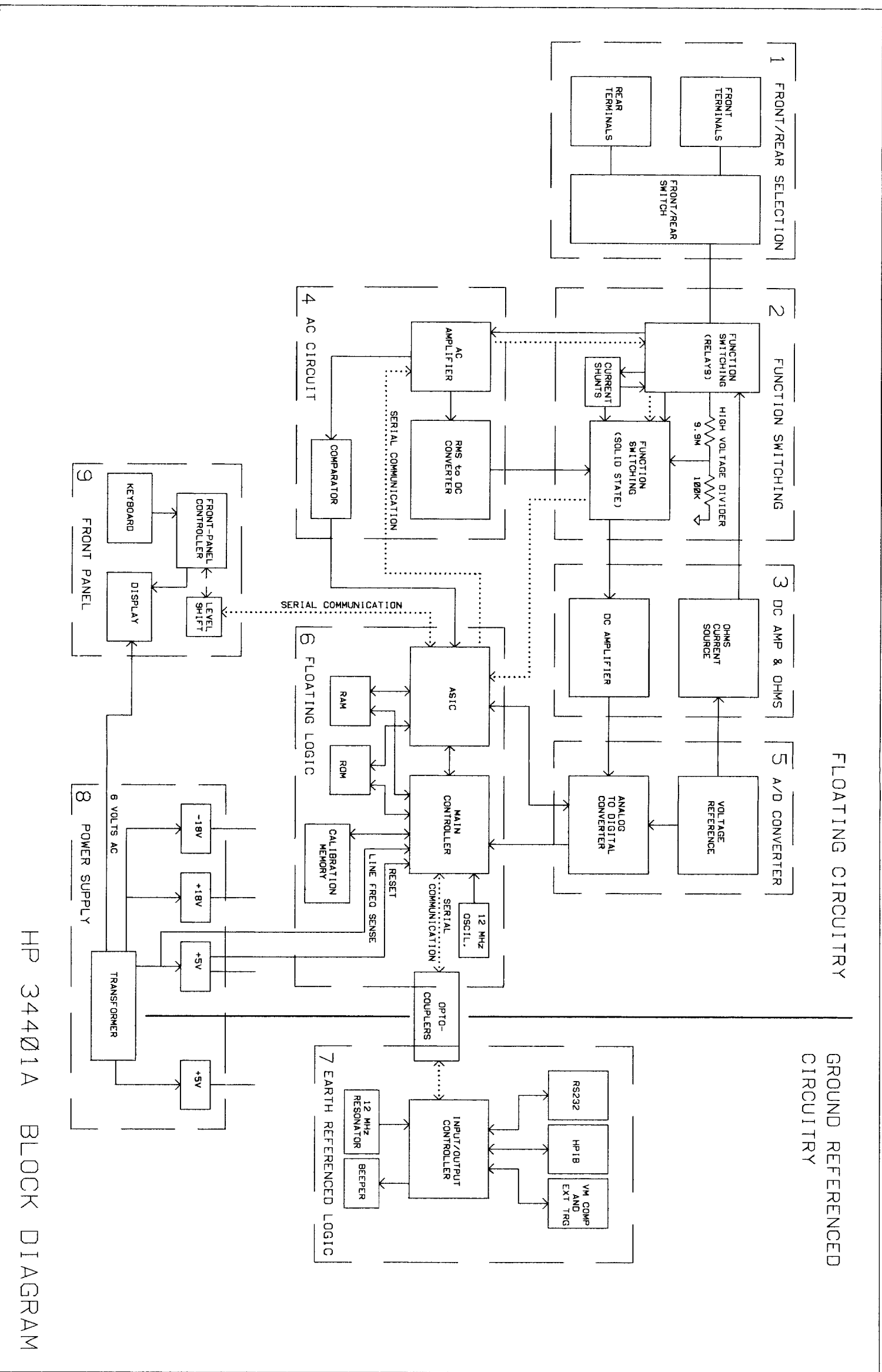

HP 34401A BLOCK DIAGRAM

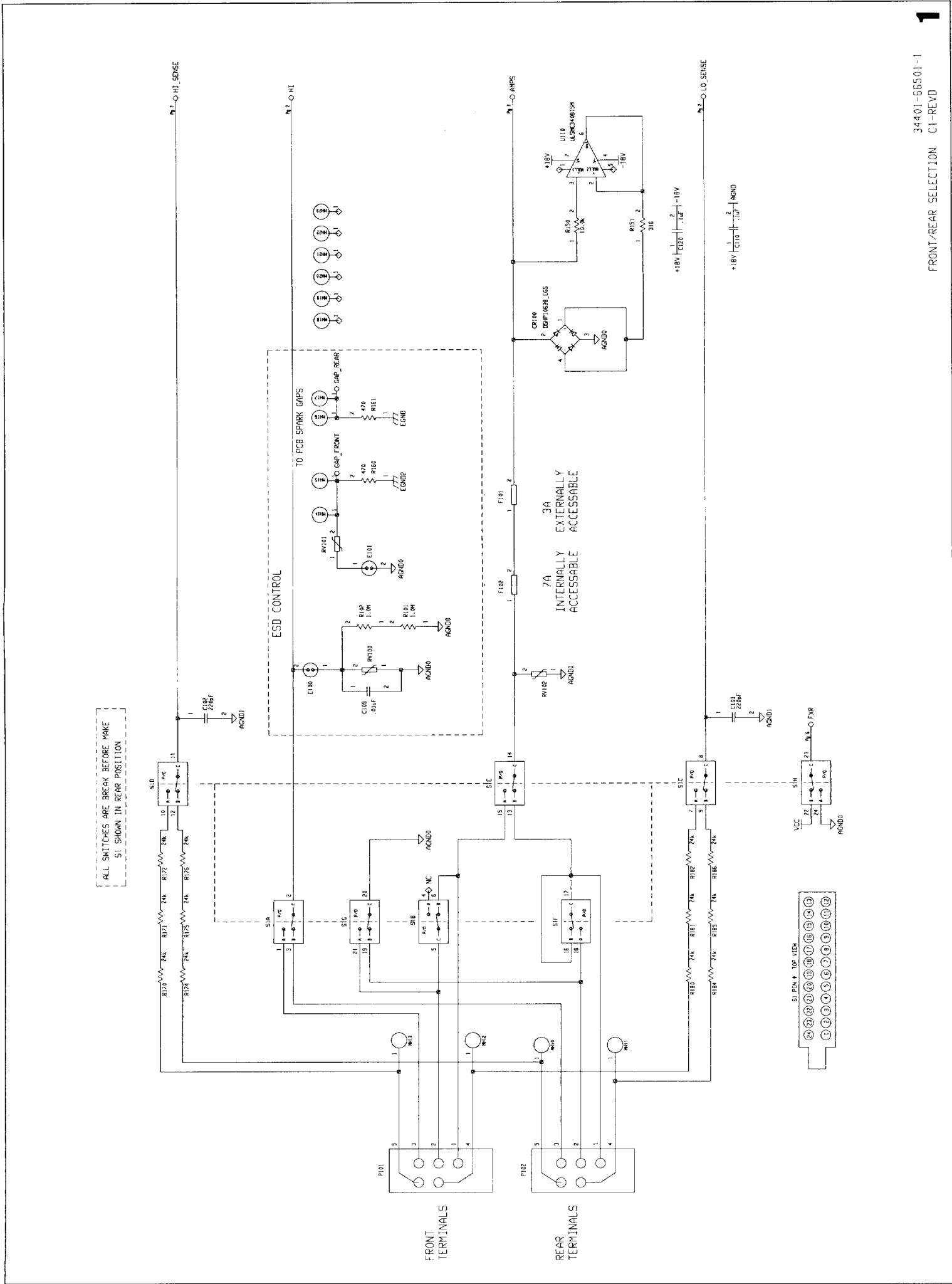

See "Function Switching" on page 95 for more information.

Function	K101	K102	K103	K104	Sense at:
0.1 V – 10 Vdc	Closed	Set	Set	Set [1]	U101-5
100 V – 1000 Vdc	Closed	Set	Reset	Set	U102-12
2-Wire Ohms	Closed	Reset	Set	Reset [2]	U101-5
4-Wire Ohms	Closed	Reset	Set	Reset [2]	[3]
AC Voltage	Closed	Set	Reset	Reset	AC_IN
Frequency/Period	Closed	Set	Reset	Reset	AC_IN
3 A, 1A DC I	Closed	Reset	Set	Reset	U101-10
100 mA, 10 mA DC I	Closed	Set	Set	Reset	U101-10
3A, 1A AC I	Closed	Reset	Set	Set	AC_IN

[1] K104 will be reset when input resistance is selected to >10,000 M Ω through the menu.

[2] K104 will be set for the 100 M Ω range.

[3] Configurations shown are for the current source output (HI) terminal. The measurement sense is accomplished through the Sense HI / Sense LO terminals.

See "DC Amplifier" on page 96 and "Ohms Current Source" on page 98 for more information.

DCV Range	U102A Divider	U101 Input	Amplifier Gain	ADC Input
100 mV		Pin 5	x100	10 V
1 V		Pin 5	x10	10 V
10 V		Pin 5	x1	10 V
100 V	1/100	Pin 8	x10	10 V
1000 V	1/100	Pin 8	x1	10 V

DCI Range	Shunt Resistor	U101-10 Input	Amplifier Gain	ADC Input
3A	0.1 Ω	300 mV	x10	3V
1A	0.1 Ω	100 mV	x100	10V
100 mA	5.1 Ω	510 mV	x10	5.1V
10 mA	5.1 Ω	51 mV	x100	5.1V

Ohms Range	Voltage Across R	Amplifier Gain	ADC Input
100 Ω	100 mV	x100	10 V
1 k Ω to 100 k Ω	1 V	x10	10 V
1 M Ω	5 V	x1	5 V
10 M Ω	5 V	x1	5 V
100 M Ω	4.5 V	x1	4.5 V

Ohms Range	Current	Open Circuit Voltage	Compliance Limit	Reference	Isource R U102D
100 Ω	1 mA	9 V	2.5 V	R202	5 k Ω
1 k Ω	1 mA	9 V	2.5 V	R202	5 k Ω
10 k Ω	100 μ A	9 V	4 V	R202	50 k Ω
100 k Ω	10 μ A	9 V	4 V	R202	500 k Ω
1 M Ω	5 μ A	9 V	8 V	R202	1 M Ω
10 M Ω	500 nA	14 V	10 V	R201	1 M Ω
100 M Ω [1]	500 nA [1]	5 V		R201	1 M Ω

[1] Measured in parallel with the internal 10 M Ω resistor.

See "AC Circuit" on page 99 for more information.

Function	Range	1st Stage	2nd Stage	ADC Input
ACV, Freq, or Period	100 mV	x0.2	x100	2 Vdc
	1 V	x0.2	x10	2 Vdc
	10 V	x0.2	x1	2 Vdc
	100 V	x0.002	x10	2 Vdc
	700 V	x0.002	x1	1.4 Vdc
ACI	3 A	x0.2	x10	0.6 Vdc
	1 A	x0.2	x100	2 Vdc

2nd Stage Gain	U306A	U306B	U306C	U306D	U304C
x1	ON	OFF	OFF	OFF	OFF
x10	OFF	ON	OFF	ON	OFF
x100	OFF	OFF	ON	ON	ON

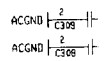
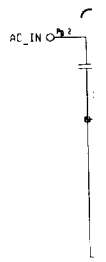

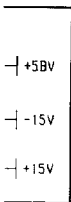
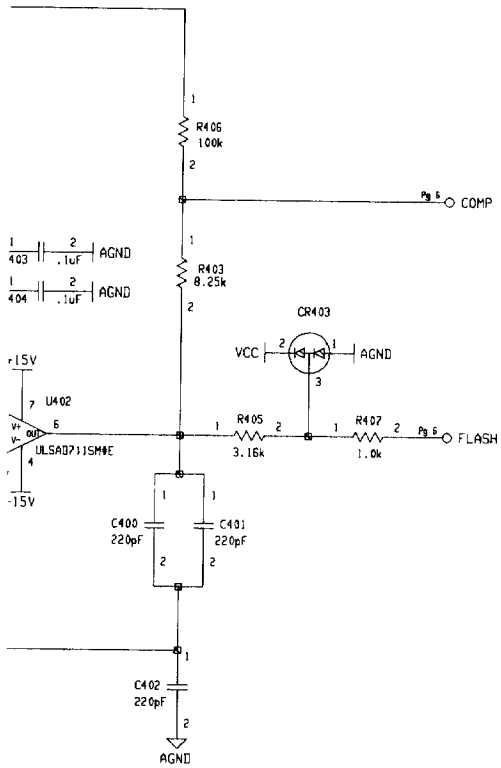

A/D CONVERTER 34401-66501-1 **5**
 C1-REVD

A/D Converter Schematic
 9-12

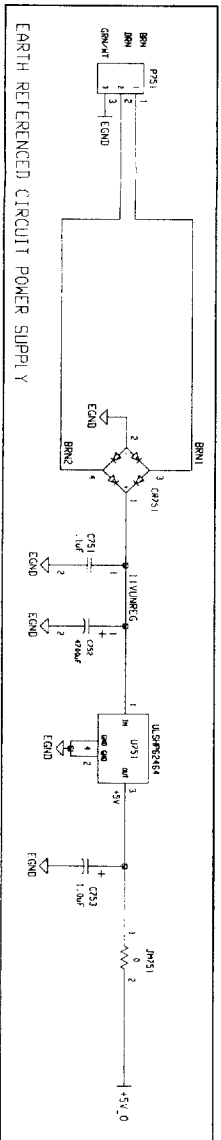
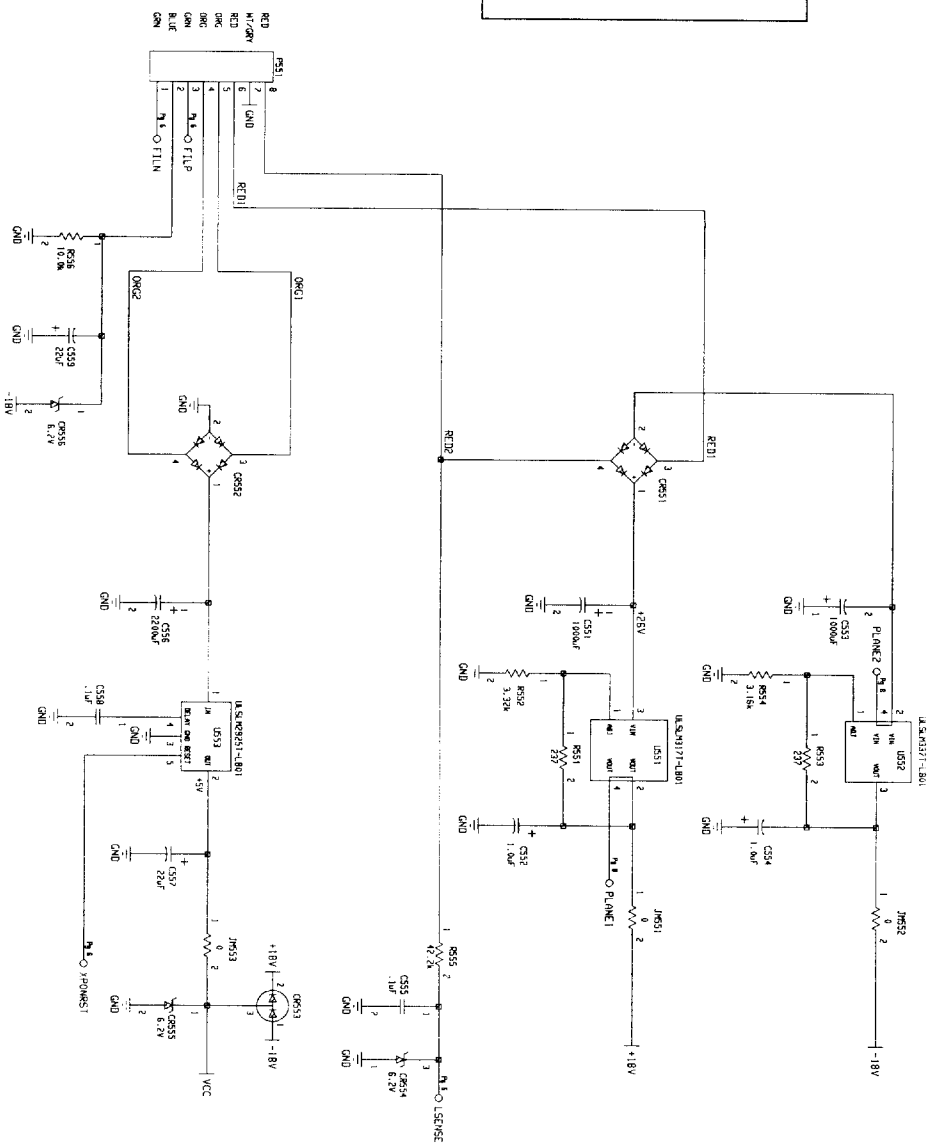
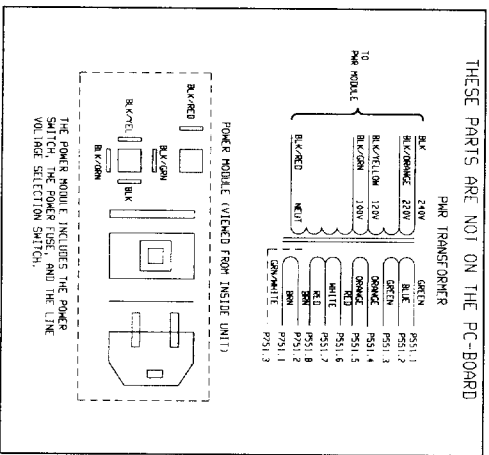
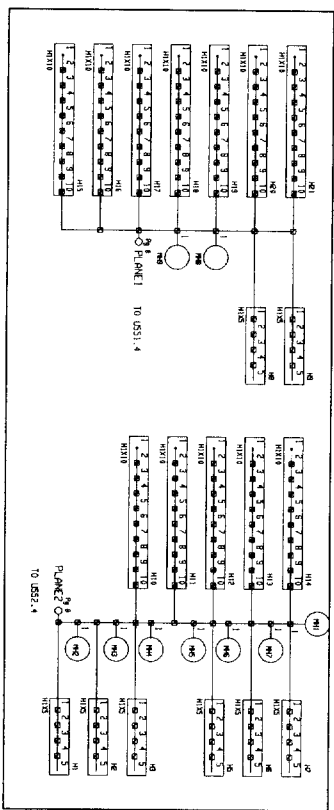

POWER SUPPLIES 34401-66501-1
C1-REV D

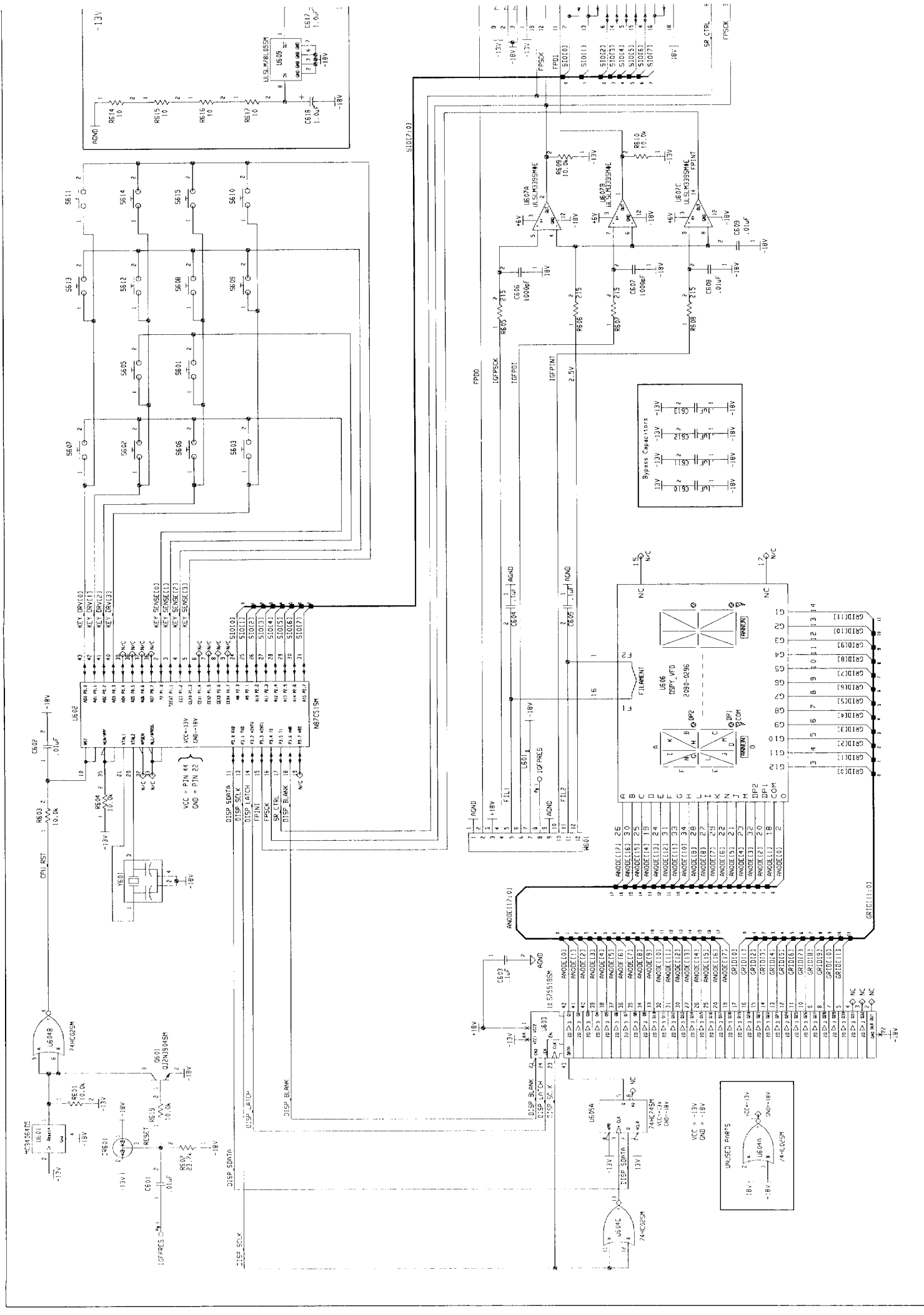

Manual Update

In order to maintain a consistent appearance across all Hewlett-Packard products, the colors on the following instruments have been changed. This update lists the changes to each product as a result of the color change. Please refer to this update when ordering replacement parts.

HP 34401A Multimeter

For Instruments with Serial Numbers >US36010000

Old HP Part Number	New HP Part Number	Reference Designation	Part Description
34401-84101	34401-84111	CVR1	Cover
34401-80101	34401-80111	FRM1	Chassis
03478-88304	34401-88304	MP1	Rear Panel / Bezel Assembly
34401-40201	34401-40211	MP2	Front Panel / Bezel Assembly
34401-43701	34401-43711	MP3	Power-On Push Rod
34401-43702	34401-43712	MP4	Front / Rear Push Rod
34401-45001	34401-45011	MP5	Carrying Handle
34420-49301	34420-49311	MP8	Window, Front-Panel Display
34401-81902	34401-81912	MP9	Flubber Keys-Front Panel
34401-86000	34401-86010	MP11-MP12	Bumpers (Front / Rear) & Power Mod Cvr
34401-69201	N/A	Exchange unit	Rebuilt HP 34401A Unit for Exchange
N/A	34401-69211	Exchange unit <i>(old color unit)</i>	<i>(for all Serial numbers with prefix 3146A)</i>
		Exchange unit <i>(new color unit)</i>	Rebuilt HP 34401A Unit for Exchange <i>(for all Serial numbers >US36010000)</i>

HP 34420A Nano Volt / Micro Ohm Meter

For Instruments with Serial Numbers >US36000100

Old HP Part Number	New HP Part Number	Reference Designation	Part Description
34401-84101	34401-84111	CVR1	Cover
34420-80101	34420-80111	FRM1	Chassis
03478-88304	34401-88304	MP1	Rear Panel / Bezel Assembly
34420-40201	34420-40211	MP2	Front Panel / Bezel Assembly
34401-43701	34401-43711	MP3	Power-On Push Rod
34401-86000	34401-86010	MP4	Bumpers (Front / Rear) & Power Mod Cvr
34401-45001	34401-45011	MP5	Carrying Handle
34420-49301	34420-49311	MP8	Window, Front-Panel Display
34420-81902	34420-81912	MP9	Flubber Keys-Front Panel
N/A	34420-69211	Exchange unit	Rebuilt HP 34420A Unit for Exchange <i>(for all serial numbers)</i>

© Copyright Hewlett-Packard Company 1996
Printed in U.S.A. September 1996 E0996



34420-90201

HP 33120A Function Generator / Arbitrary Waveform Generator
For Instruments with Serial Number >US36001000

Old HP Part Number	New HP Part Number	Reference Designation	Part Description
33120-84101	33120-84111	CVR1	Cover
33120-80101	33120-80111	FRM1	Chassis
03478-88304	34401-88304	MP1	Rear Panel / Bezel Assembly
33120-40201	33120-40211	MP2	Front Panel / Bezel Assembly
34401-43701	34401-43711	MP3	Power-On Push Rod
34401-45001	34401-45011	MP5	Carrying Handle
33120-49301	33120-49311	MP8	Window, Front-Panel Display
33120-81901	33120-81911	MP9	Flubber Keys-Front Panel
33120-87401	33120-87411	MP15	Knob
34401-86000	34401-86010	MP11-MP13	Bumpers (Front/Rear) & Power Mod Cvr
33120-69201	N/A	Exchange unit	Rebuilt HP 33120A Unit for Exchange
		<i>(old color unit)</i>	<i>(For Serial numbers <US34003500)</i>
33120-69202	N/A	Exchange unit	Rebuilt HP 33120A Unit for Exchange
		<i>(old color unit)</i>	<i>(For Serial numbers >US34003500 & <US36001000)</i>
N/A	33120-69213	Exchange unit	Rebuilt HP 33120A Unit for Exchange (with Opt. 001)
			<i>(for all Serial numbers)</i>
N/A	33120-69212	Exchange unit	Rebuilt HP 33120A Unit for Exchange
		<i>(new color unit)</i>	<i>(For Serial numbers >US36001000)</i>

Rack Mounting Kits

The part numbers for the new Rack Mounting Kits for the HP 34401A, 34420A, and 33120A are listed below.

- To rack mount a single instrument, order:
 Adapter Kit: 5063-9240
- To rack mount two instruments side-by-side, order:
 Lock-Link Kit: 5061-9694
 Flange Kit: 5063-9212
- To install one or two instruments in a sliding support shelf, order:
 Shelf: 5063-9255
 Slide Kit: 1494-0015
 (for a single instrument, also order filler panel 5002-3999)

Manual Update

The following changes apply to the manuals listed below. To update your manual, cut along the dashed lines below and place the information on the appropriate page.

- HP 33120A Service Guide (part number 33120-90013)
- HP 34401A Service Guide (part number 34401-90013)
- HP 34420A Service Guide (part number 34420-90010)

Change 1: Applies to all three manuals listed above.

Add the following information to the bottom of the *Page 1*:

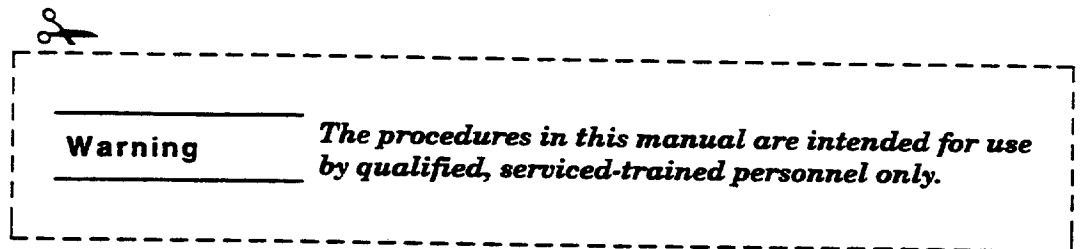

Change 2: Applies to the HP 34401A and HP 34420A Only.

HP 34401A Service Guide (Page 74): Add the following information in the left-hand column next to *Step #5*.

HP 34420A Service Guide (Page 84): Add the following information in the left-hand column next to *Step #4*.

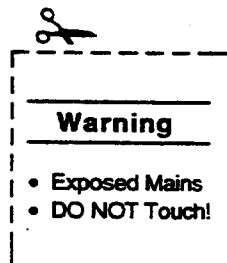

Copyright © Hewlett-Packard Company 1997
Printed in U.S.A. April 1997 E0497



34401-90096

Front-Panel Menu Reference

The menu is organized in a top-down tree structure with three levels.

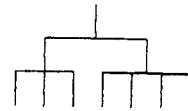

To turn on menu press:



To move
left or right



To move
up or down

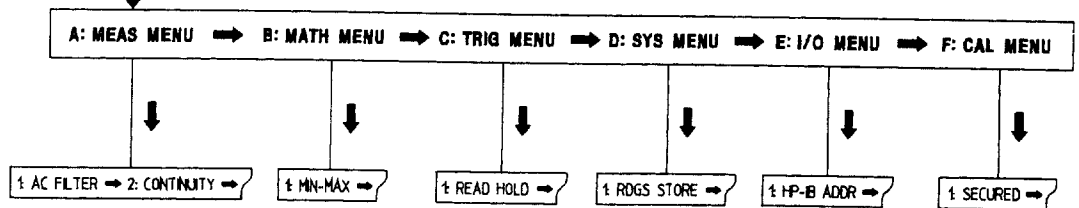

To enter command press:



A: MEASurement MENU

1: AC FILTER → 2: CONTINUITY → 3: INPUT R → 4: RATIO FUNC → 5: RESOLUTION

B: MATH MENU

1: MIN-MAX → 2: NULL VALUE → 3: dB REL → 4: dBm REF R → 5: LIMIT TEST → 6: HIGH LIMIT → 7: LOW LIMIT

C: TRIGger MENU

1: READ HOLD → 2: TRIG DELAY → 3: N SAMPLES

D: SYStem MENU

1: RDGS STORE → 2: SAVED RDGS → 3: ERROR → 4: TEST → 5: DISPLAY → 6: BEEP → 7: COMMA → 8: REVISION

E: Input / Output MENU

1: HP-IB ADDR → 2: INTERFACE → 3: BAUD RATE → 4: PARITY → 5: LANGUAGE

F: CALibration MENU*

1: SECURED → [1: UNSECURED] → [2: CALIBRATE] → 3: CAL COUNT → 4: MESSAGE

* The commands enclosed in square brackets ([]) are "hidden" unless the multimeter is UNSECURED for calibration.