

NOTE

The Fluke Model 5440B/AF is a Direct Voltage Calibrator which is very similar to the Fluke Model 5440B with the following functional differences:

1. The Procedure Storage Module is not included with the 5440B/AF.
2. The rear output capability is not included with the 5440B/AF.

Standard features of the 5440B such as boost mode operation and 60 mA output capability on $\pm 11V$ and $\pm 22V$ ranges are included in the 5440B/AF.

5440B/AF

DIRECT VOLTAGE CALIBRATORS

Operator Manual

P/N 765602
January 1987

©1987, John Fluke Mfg. Co., Inc., all right reserved. Litho in U.S.A.



The Fluke Corporation is pleased to hereby grant GIDEP (Government-Industry Data Exchange Program) permission to reproduce the manuals listed in the attachment. Permission is granted on the condition that you legibly reproduce on the copies the legend "Reproduced With Permission".

It is our understanding from your request dated January 23, 2001, that the purpose for copying these manuals is to include them in the GIDEP database, and that the material won't be copied for any other purpose.

Thank you for your cooperation, and for your interest in Fluke.

Sincerely,

**Beverly A. Summers
Paralegal
Fluke Corporation
Intellectual Property Law Dept.
Direct: (425) 446-5770 [voice]
(425) 446-5117 [fax]
beverly.summers@fluke.com [e-mail]**

WARNING



HIGH VOLTAGE

is used in the operation of this equipment

DEATH ON CONTACT

may result if personnel fail to observe safety precautions

TO AVOID ELECTRICAL SHOCK HAZARD, THE OPERATOR SHOULD NOT ELECTRICALLY CONTACT THE OUTPUT HI OR SENSE HI TERMINALS OF THE INSTRUMENT. DURING NORMAL OPERATION OR SYSTEM SELF TEST, LETHAL VOLTAGES OF UP TO 1100V DC MAY BE PRESENT ON THESE TERMINALS. IN THE EVENT OF MULTIPLE INSTRUMENT FAILURES, LETHAL VOLTAGES OF UP TO 1400V DC MAY BE PRESENT ON THESE TERMINALS.

Never work on the instrument unless there is another person nearby who is familiar with the operation and hazards of the equipment and who is competent in administering first aid. When the technician is aided by operators, he must warn them about dangerous areas.

Whenever possible, the power supply to the equipment must be shut off before beginning work on the equipment. Take particular care to ground every capacitor likely to hold a dangerous potential. When working inside the equipment, after the power has been turned off, always ground every part before touching it.

Be careful not to contact high-voltage connections for the line power ac input connections when installing or operating this equipment.

Whenever the nature of the operation permits, keep one hand away from the equipment to reduce the hazard of current flowing through vital organs of the body.



FIRST AID FOR ELECTRIC SHOCK

RESCUE

FREE VICTIM FROM CONTACT WITH LIVE CONDUCTOR QUICKLY. AVOID CONTACT WITH EITHER LIVE CONDUCTOR OR VICTIM'S BODY.

Shut off high voltage at once and ground circuit. If high voltage cannot be turned off quickly, ground circuit.

An ax with a dry wooden handle may be used to cut high voltage line. Use extreme caution to avoid resulting electric flash.

If circuit cannot be broken or grounded, use a dry board, dry clothing, or other nonconductor to free victim.

SYMPTOMS

NEVER ACCEPT ORDINARY AND GENERAL TESTS FOR DEATH.

Symptoms of electric shock may include unconsciousness, failure to breathe, absence of pulse, pallor, and stiffness, as well as severe burns. **WHENEVER VICTIM IS NOT BREATHING PROPERLY, GIVE ARTIFICIAL RESPIRATION.**

TREATMENT

START ARTIFICIAL RESPIRATION IMMEDIATELY.

Perform artificial respiration at scene of accident, unless victim's or operator's life is endangered. **IN THIS CASE ONLY**, remove victim to safe location nearby. If new location is more than a few feet away, give artificial respiration while victim is being moved.

After starting artificial respiration, continue without loss of rhythm for at least **FOUR HOURS**, or until victim is breathing without help. If you have to change operators while giving artificial respiration, do so without losing rhythm of respiration.

AFTER VICTIM REVIVES

Be prepared to resume artificial respiration, as he may stop breathing again.

When victim is **COMPLETELY CONSCIOUS**, give him a stimulant (**NOT AN ALCOHOLIC DRINK**) such as a teaspoonful of aromatic spirits of ammonia in a small glass of water, hot coffee, or hot tea.

Keep victim warm and lying down until he has been conscious for at least fifteen minutes.

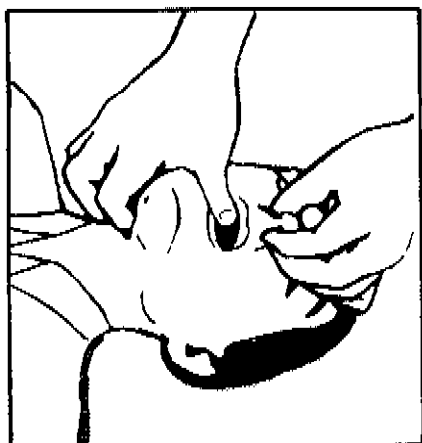

POSITION VICTIM

Place victim in face-upward position and kneel close to his ear.

CLEAR THROAT

Turn head to one side and quickly wipe out any fluid, mucus, or foreign body from mouth and throat with fingers.

OPEN AIR PASSAGE

Tilt head back and extend neck to open air passage.

LIFT JAW FORWARD

Place thumb in victim's mouth and grasp jaw firmly. Lift jaw forward to pull tongue out of air passage. Do not attempt to hold or depress tongue.



PINCH NOSTRILS CLOSED

With other hand pinch nostrils closed to prevent air leak.

FORM TIGHT SEAL WITH LIPS

Rescuer's wide-open mouth completely surrounds and seals open mouth of victim. This is not a kissing or puckered position — mouth of rescuer must be wide-open.

BLOW

Exhale firmly into victim's mouth until chest is seen to lift. This can be seen by rescuer without difficulty.



REMOVE MOUTH AND INHALE

During this time, rescuer can hear and feel escape for air from lungs. Readjust position if air does not flow freely in and out of victim's lungs.

Continue at a rate of 12 to 20 times per minute.

Breathing should be normal in rate with only moderate increase in volume, so that rescue breathing can be continued for long periods without fatigue. Do not breathe too forcibly or too large a volume if victim is an infant or small child.

Table of Contents

SECTION	TITLE	PAGE
1	INTRODUCTION	1-1
1-1.	GENERAL DESCRIPTION	1-1
1-2.	THE CALIBRATOR IN AN INSTRUMENT CLUSTER	1-2
1-3.	With an Amplifier (5440B Only)	1-2
1-4.	In an Automated Calibration Workstation	1-3
1-5.	THE 732A DIRECT VOLTAGE REFERENCE STANDARD AND THE DIRECT VOLTAGE MAINTENANCE PROGRAM	1-3
1-6.	ACCESSORIES	1-4
1-7.	THE MANUAL SET	1-5
1-8.	SPECIFICATIONS	1-5
1-9.	INTERPRETING SPECIFICATIONS	1-9
1-10.	Accuracy and Uncertainty	1-9
1-11.	Absolute Uncertainty	1-10
1-12.	Relative Uncertainty	1-10
1-13.	Stability	1-10
2	INSTALLATION AND FAMILIARIZATION	2-1
2-1.	INTRODUCTION	2-1
2-2.	UNPACKING AND INSPECTION	2-1
2-3.	PLACEMENT AND RACK-MOUNTING	2-1
2-4.	CONNECTING TO LINE VOLTAGE	2-2
2-5.	Line Voltage Selection	2-2
2-6.	Ground Connection	2-2
2-7.	Fuse Replacement	2-2
2-8.	FRONT AND REAR PANEL FEATURES	2-2
2-9.	The POWER Key	2-9
2-10.	The OUTPUT STATE Keys	2-9
2-15.	The Soft Keys and Menus	2-10
2-16.	The DATA ENTRY Keys	2-12
2-17.	The EDIT OUTPUT Keys	2-12
2-18.	The MEMORY CONTROL Keys (5440B Only)	2-12
2-19.	The RESET Key	2-12
2-20.	CALIBRATION CONNECTIONS	2-13
2-21.	Recommended Cable and Connector Types	2-13
2-22.	OUTPUT and DIVIDER Connections	2-13
2-23.	SENSE Connections	2-13
2-24.	GUARD Connections	2-14
2-27.	CHANGING FROM FRONT TO REAR OUTPUTS	2-15

TABLE OF CONTENTS

SECTION	TITLE	PAGE
2-28.	INSTRUMENT MESSAGES	2-16
2-29.	SERVICE INFORMATION	2-17
3	FRONT PANEL OPERATION	3-1
3-1.	INTRODUCTION	3-1
3-2.	PRELIMINARY PROCEDURES	3-1
3-3.	Power-Up	3-1
3-4.	Warm-Up	3-2
3-5.	Internal Calibration	3-2
3-6.	External Calibration	3-9
3-7.	SELECTING A VOLTAGE OUTPUT	3-9
3-8.	Entering a Voltage	3-9
3-9.	Editing a Voltage	3-10
3-10.	SELECTING A DIVIDED VOLTAGE OUTPUT	3-10
3-11.	Procedure	3-10
3-12.	Considerations	3-11
3-13.	DISPLAYING UUT ERROR	3-11
3-14.	Basic Error Display	3-11
3-15.	Entering Tolerances	3-12
3-16.	Converting UUT Specifications	3-12
3-17.	SETTING OUTPUT LIMITS	3-13
3-18.	Setting Current Limits	3-13
3-19.	Setting Voltage Limits	3-13
3-20.	Voltage Monitoring	3-14
3-21.	SELECTING A BOOST OUTPUT (5440B ONLY)	3-14
3-22.	Voltage Boost Output	3-14
3-23.	Current Boost Output	3-15
3-24.	SETTING COMMUNICATION PARAMETERS	3-16
3-25.	PRINTING DATA	3-16
3-26.	Printing a Header	3-16
3-27.	Printing UUT Calibration Results	3-17
3-28.	Printing Internal Calibration Constants	3-18
3-29.	Printing Stored Procedures (5440B Only)	3-18
3-30.	PERFORMING SELF-TESTS	3-18
3-31.	Digital Sel-Test	3-19
3-32.	Analog Self-Test	3-19
3-33.	High Voltage Self-Test	3-20
3-34.	CREATING AND EDITING PROCEDURES (5440B ONLY)	3-20
3-35.	Creating a Procedure	3-21
3-36.	Executing a Procedure	3-21
3-37.	Editing a Procedure	3-21
3-41.	Exiting a Procedure	3-22
3-42.	Clearing Internal Memory	3-22
3-43.	STORING PROCEDURES (5440B ONLY)	3-23
3-44.	Transferring from Module to Internal Memory	3-23
3-45.	Transferring from Internal Memory to Module	3-23
3-46.	EXTERNAL CALIBRATION PROCEDURE	3-24
4	REMOTE OPERATION	4-1
4-1.	INTRODUCTION	4-1
4-2.	IEEE-488 INTERFACE FUNCTIONS	4-1

TABLE OF CONTENTS

SECTION	TITLE	PAGE
4-3.	CONNECTING THE CALIBRATOR TO THE BUS	4-1
4-4.	Setting the IEEE-488 Address	4-1
4-5.	Connecting IEEE-488 Cables	4-2
4-6.	IEEE-488 Bus Restrictions	4-2
4-7.	REMOTE AND LOCAL STATES	4-2
4-8.	Local States	4-2
4-9.	Remote States	4-3
4-13.	NOTATION AND SYNTAX CONVENTIONS	4-4
4-14.	INCOMING CHARACTER TRANSFORMATIONS	4-4
4-15.	CALIBRATOR STATEMENT	4-4
4-16.	Message Sequence	4-10
4-17.	DEVICE DEPENDENT MESSAGES	4-10
4-18.	Response Messages	4-11
4-19.	Setup Status Report	4-12
4-20.	Long Term Operation Report	4-12
4-21.	Remote Error Report	4-14
4-22.	SRQ and Serial Poll	4-14
4-25.	Device Dependent Message Summary Table	4-16
5	THE RS-232-C INTERFACE	5-1
5-1.	INTRODUCTION	5-1
5-3.	CONNECTING TO THE RS-232-C PORT	5-2
5-4.	Configuring the RS-232-C Shorting Plug	5-2
5-5.	Setting the Baud Rate	5-2
5-6.	RS-232-C Accessory Cables	5-3
5-7.	RS-232-C OPERATION	5-3
6	OPTIONS AND ACCESSORIES	6-1
6-1.	INTRODUCTION	6-1
6-2.	OPTIONAL REAR PANEL OUTPUT TERMINALS (5442A ONLY)	6-1
6-3.	ADDITIONAL PROCEDURE STORAGE MODULE (5440B ONLY)	6-1
6-4.	LOW THERMAL EMF PLUG-IN CABLES	6-1
6-5.	LOW THERMAL EMF SPADE-LUG CABLES	6-1
6-6.	ACCESSORY CABLES	6-1
6-7.	1780 RS-232-C Cable	6-2
6-8.	5205A Interface Cable (5440B Only)	6-2
6-9.	5220A Interface Cable (5440B Only)	6-2
6-10.	Armored IEEE-488 Interface Cables (Y8021, Y8022, Y8023)	6-2

List of Tables

TABLE	TITLE	PAGE
1-1.	Features and Capabilities	1-2
1-2.	Accessories and Other Calibration Equipment	1-4
1-3.	General Specifications	1-5
1-4.	Physical and Environment Specifications	1-8
2-1.	Standard Equipment	2-2
2-2.	Line Fuse Values	2-5
2-3.	Front Panel Controls, Indicators, and Connectors	2-5
2-4.	Rear Panel Controls, Indicators, and Connectors	2-7
2-5.	Power-Up Default Settings	2-9
2-6.	Instrument Messages	2-19
3-1.	Summary of Operations	3-1
3-2.	Soft Key Menus	3-3
3-3.	Voltage Boost Default Settings	3-15
3-4.	Current Boost Default Settings	3-15
4-1.	Interface Functions	4-2
4-2.	IEEE-488 Interface Messages and IFC Command Line	4-5
4-3.	Calibrator Notation and Syntax Conventions	4-6
4-4.	Responses to Calibrator Request Messages	4-12
4-5.	Setup Status Codes	4-13
4-6.	Long-Term Operation State Codes	4-13
4-7.	5440B/5442A Device Dependent Messages	4-16
5-1.	RS-232-C Specifications	5-1

List of Illustrations

FIGURE	TITLE	PAGE
Frontispiece	5440 Series Direct Voltage Calibrator	viii
1-1.	Outline Dimensions	1-1
2-1.	Front Panel Controls, Indicators, and Connectors	2-3
2-2.	Rear Panel Controls, Indicators, and Connectors	2-4
2-3.	Alphanumeric Display Examples	2-7
2-4.	Keys Which Call Up Soft-Key Menus	2-10
2-5.	Soft Keys	2-11
2-6.	External Sense Connections	2-14
2-7.	Proper External Guard Connections	2-16
2-8.	Changing From Front to Rear Terminals	2-18
3-1.	Example Header Listing	3-11
3-2.	Example Results Listing	3-11
3-3.	Example Calibration Constants Listing	3-12
3-4.	Example Stored Procedure Listing	3-12
3-5.	External Calibration Connections	3-19
4-1.	IEEE-488 Connector	4-3
4-2.	Syntax Diagram Interpretation	4-6
4-3.	Calibrator Statement Syntax	4-7
4-4.	Calibrator Software Viewed From the IEEE-488 Interface	4-10
4-5.	Calibrator Response Message Syntax	4-11
4-6.	SRQ Mask and Serial Poll Status Byte	4-15
5-1.	RS-232-C Shorting Plug	5-2

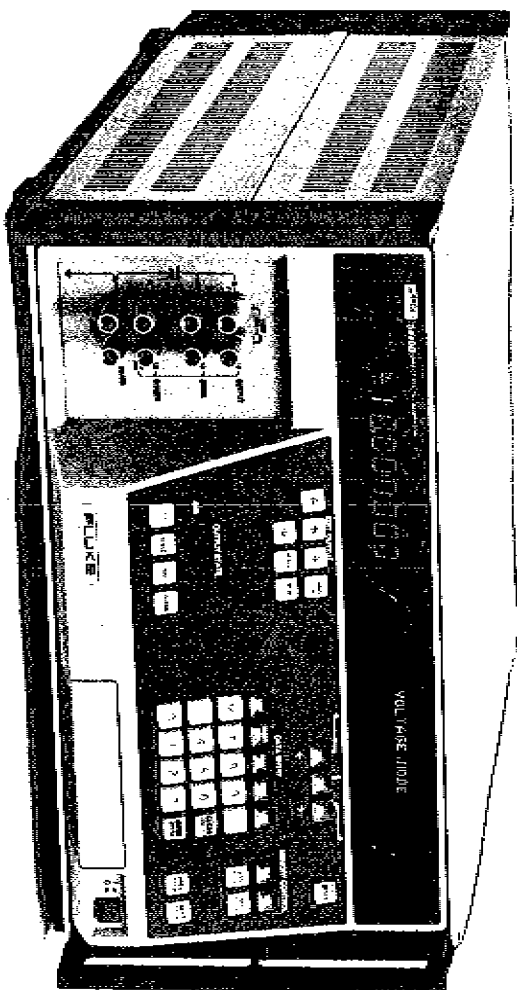

Frontpiece. 5440 Series Direct Voltage Calibrator

Section 1

Introduction

GENERAL DESCRIPTION

1-1.

The 5440 Series Direct Voltage Calibrators are programmable or stand-alone dc voltage calibrators with an output voltage range of -1100V dc to +1100V dc and uncertainty of three to four parts per million (referred to national standards). Designed for use in production environments as well as in calibration laboratories, the 5440 Series Calibrators operate without degradation of uncertainty specifications over a temperature range of $\pm 5^{\circ}\text{C}$ from the calibration temperature. The 5440 Series can accurately calibrate meters of up to 7-1/2 digits.

The 5440 Series are convenient to operate. The front panel is tilted to make data entry easy, and the two vacuum fluorescent displays are easy to read. A numeric Output Display shows the output value; a separate, 40-character, Alphanumeric Display indicates the operating mode, displays menus of operating features, prompts for entries, and shows other instrument messages.

The 5440 Series are equipped with features that simplify operation. Special features include:

- You can preset output voltage and current limits, and can preset tolerance limits for the unit under test.
- An automatic Internal Calibration procedure corrects for drift in internal offsets and resistor ratios.
- A display-prompted, semi-automatic External Calibration procedure corrects for long-term reference drift.
- Output voltage and current levels are automatically monitored.
- Output settings can be entered directly with the keyboard and can be incremented and decremented with convenient front panel controls.
- Automatic self-tests check the Calibrator's status and diagnose internal faults.
- The IEEE-488 bus address and RS-232-C baud rate can be set from the front panel keyboard.

There are two models in the 5440 Series: the 5440B and the 5442A. Each model's features and capabilities are summarized in Table 1-1.

INTRODUCTION
THE CALIBRATOR IN AN INSTRUMENT CLUSTER

Table 1-1. Features and Capabilities

FEATURE	5440B	5442A	DESCRIPTION
Voltage Output	Yes	Yes	Provides a selectable dc voltage through the OUTPUT terminals.
Divider Output	Yes	Yes	Provides high-resolution output from -2.2V to +2.2V dc at the DIVIDER terminals.
Boost Output	Yes	No	Provides a current or high-voltage output by using the 5440B to drive a Fluke 5220A Transconductance Amplifier or Fluke 5205A Precision Power Amplifier.
Editing	Yes	Yes	Allows you to edit and modify the selected output value, and automatically calculates the error of the unit under test in percent or parts per million (ppm).
Menus and Soft Keys	Yes	Yes	Menus of operating features are called up by front panel keys; the soft keys are used to make selections within these menus.
Procedure Storage Module	Yes	No	Non-volatile storage of sequences of up to 60 Calibrator settings to semi-automate your calibration procedures.
IEEE-488 Interface	Yes	Yes	Allows you to interface the Calibrator with other IEEE-488-compatible instruments, such as an instrument controller, for remote operation.
RS-232-C Interface	Yes	Yes	Allows you to interface the Calibrator with a serial printer or monitor for printing or displaying your calibration procedures and test results.
Rear Output Terminals	Yes	Optional	Allows you to connect the equipment under test to output terminals on the rear panel of the Calibrator. Convenient for systems applications.

THE CALIBRATOR IN AN INSTRUMENT CLUSTER

1-2.

The 5440 Series Calibrators are well suited to operating as part of an instrument cluster or as part of a Fluke Automated Calibration Workstation. A few of the possible combinations of instruments you may wish to use with your 5440B or 5442A are described in the following paragraphs.

With an Amplifier (5440B Only)

1-3.

You may wish to use the 5440B with a power amplifier or transconductance amplifier. The 5440B may be used to drive a Fluke 5205A Precision Power Amplifier or a Fluke 5220A Transconductance Amplifier. In these configurations, the meter to be calibrated is connected to the amplifier's output terminals; operation is controlled from the Calibrator, using either the front panel or remote control.

In an Automated Calibration Workstation

1-4.

The 5440B and 5442A are also used in Computer-Aided Benchtop Clusters and Fluke Automated Calibration Workstations, such as the Model 7405A. In these configurations, the 5440B or 5442A is supplemented with extensive calibration software.

All clusters and workstations are upwardly compatible. This means that you can buy a single 5440B or 5442A now, and add additional instruments and software as your needs grow. Your Calibrator will remain an integral part of your system. Your Fluke Sales Engineer can give you more information on expanding your calibration equipment.

THE 732A DIRECT VOLTAGE REFERENCE STANDARD AND THE DIRECT VOLTAGE MAINTENANCE PROGRAM

1-5.

You can maintain the traceability of your 5440 Series Calibrator to national voltage standards with the Fluke 732A Direct Voltage Reference Standard. The 732A is a solid-state reference standard which provides significant performance improvements in stability, ruggedness, and transportability over standard cells. Its low, stable, and predictable drift rate allows accurate extrapolation of the output voltage over long time intervals.

The 732A can be directly certified by a higher-level laboratory, such as with the Fluke Direct Voltage Maintenance Program (DVMP). The advantages of the DVMP include:

- Traceability for your calibration laboratory to the U.S. national standard volt with significant cost reduction over direct U.S. National Bureau of Standards (NBS) calibration.
- Uncertainty of your 732A within a few tenths of a ppm.
- Complies with MIL-STD-45662.
- Saves you from investing in redundant hardware; your equipment never needs to leave your laboratory.
- Avoids the possibility of accidental loading and destruction as with saturated standard cells.

Four services are offered under the DVMP, separately or in combination:

1. Calibration of the 732A prior to delivery and shipment under power.
2. Certification of output and drift rate of the 732A prior to delivery with shipment under power.
3. Certification of your laboratory 10V reference on site, using a Fluke-owned 732A transfer standard.
4. Certification of additional laboratory references at the same site.

Your Fluke Sales Engineer can give you additional information and help you tailor a program to fit your needs and applications.

ACCESSORIES

1-6.

Accessories and other useful calibration instruments are listed in Table 1-2.

Table 1-2. Accessories and Other Calibration Equipment

ACCESSORIES	DESCRIPTION
5440B-7001	Additional Procedure Storage Module Stores up to 60 5440B front panel settings Non-Volatile EAROM Self Contained
5440B-7002	Low Thermal EMF Plug-In Cables 3 special-length cables with shielded leads Used in conjunction with 732A/752A/845AR
5440B-7003	Low Thermal EMF Spade-Lug Cables 3 special-length cables with shielded leads Used in conjunction with 732A/752A/845AR
Y8021	IEEE-488 Compatible Cables (Armored) 1m, 2m, and 4m lengths
Y8022	
Y8023	
Y5001	Interface Cable for 5205A
Y5002	Interface Cable for 5220A
Y1709	RS-232-C Cable for 1780A Display
INSTRUMENT	DESCRIPTION
732A	DC Reference Standard 10V, 1.018V, and 1V Reference Standard Used with 752A and 845AR to calibrate 5440 Series
752A	Reference Divider 10:1 and 100:1 voltage division capability Used with 732A and 845AR to calibrate 5440 Series
845AR	High Impedance Voltmeter, Null Detector Used with 732A and 752A to calibrate 5440 Series
5205A	Precision Power Amplifier Increases 5440B load current to 100 mA Increases 5440B voltage output to 1500V Controlled from 5440B Requires Y5001 Cable
5220A	Transconductance Amplifier 2A to 20A output capability Controlled from 5440B Requires Y5002 Cable
1780A	Infotouch Display, RS-232-C interface Lists calibration results Lists internal calibration constants

THE MANUAL SET

1-7.

The 5440B and 5442A are documented by a set of manuals and tutorials. The 5440 Series Operator Manual gives you information on setting up the Calibrator, operating the front panel, and using the remote control and print-out capabilities. The 5440 Series Quick Reference Guide gives you a quick reference to 5440 Series remote control commands. The 5440 Series Service Manual provides complete service information, including the theory of operation, troubleshooting procedures, external calibration procedures, and general service procedures.

The 5440 Series Getting Started Guide explains how to set up the Calibrator and presents a few sample operations. This is especially useful to the first-time user.

This Operator Manual gives you all the information necessary for daily operation of the Calibrator. The information is arranged as follows:

- Section 1 explains the general concept and specifications of the Calibrator and describes its use with other equipment.
- Section 2 explains how to set up the Calibrator and prepare it for operation. Section 2 also familiarizes you with the front and rear panel features.
- Section 3 explains how to operate the Calibrator from the front panel.
- Section 4 explains how to set up the IEEE-488 interface and operate the Calibrator via remote control.
- Section 5 explains how to set up the RS-232-C interface for printing or displaying data.

SPECIFICATIONS

1-8.

General specifications for the 5440 Series Calibrators are shown in Table 1-3, and physical and environmental specifications are shown in Table 1-4. Outline dimensions are shown in Figure 1-1.

Table 1-3. General Specifications

Specifications apply to 5440B and 5442A unless otherwise noted.				
Output Voltage: 0 to 1100V				
Output Current: (See Resolution Specification)				
5440B:				
Output Uncertainty Compared to Calibration Standards, ±5°C				
RANGE	UNCERTAINTY SPECIFICATION: ±(PPM OF OUTPUT + MICROVOLTS)			
	30 DAYS	90 DAYS	180 DAYS	1 YEAR
0V to 11V	1.5 + 5 μV	2.0 + 5 μV	2.5 + 5 μV	3.5 + 5 μV
11V to 22V	1.5 + 8 μV	2.0 + 8 μV	2.5 + 8 μV	3.5 + 8 μV
22V to 275V	2.5 + 100 μV	3.5 + 100 μV	4.5 + 100 μV	6.0 + 100 μV
275V to 1100V	2.5 + 400 μV	3.5 + 400 μV	4.5 + 400 μV	6.0 + 400 μV
DIVIDED OUTPUT				
0-220 mV	4 + 0.5 μV	5 + 0.5 μV	6.5 + 0.5 μV	10 + 0.5 μV
0.22-2.2V	3 + 1 μV	4.5 + 1.0 μV	6 + 1.0 μV	8 + 1.0 μV

**INTRODUCTION
SPECIFICATIONS**

Table 1-3. General Specifications (cont)

5442A: Output Uncertainty Compared to Calibration Standards, $\pm 5^{\circ}\text{C}$				
RANGE	UNCERTAINTY SPECIFICATION: \pm(PPM OF OUTPUT + MICROVOLTS)			
	30 DAYS	90 DAYS	180 DAYS	1 YEAR
0V to 11V	2.5 + 5 μV	3.0 + 5 μV	4.5 + 5 μV	6.5 + 5 μV
11V to 22V	2.5 + 8 μV	3.0 + 8 μV	4.5 + 8 μV	6.5 + 8 μV
22V to 275V	3.0 + 100 μV	3.5 + 100 μV	5.0 + 100 μV	7.0 + 100 μV
275V to 1100V	3.0 + 400 μV	4.0 + 400 μV	5.5 + 400 μV	8.0 + 400 μV
DIVIDED OUTPUT				
0-220 mV	6 + 0.5 μV	7 + 0.5 μV	9 + 0.5 μV	12 + 0.5 μV
0.22-2.2V	4 + 1 μV	6 + 1.0 μV	8 + 1.0 μV	11 + 1.0 μV
Uncertainty of Calibration Standards (Fluke 732A and 752A) Compared to National Standards				
RANGE	UNCERTAINTY OF STANDARDS			
0V to 11V	1.5 PPM			
11V to 22V	1.5 PPM			
22V to 275V	1.7 PPM			
275V to 1100V	2.0 PPM			
0V to 220 mV	4.0 PPM			
0.22 to 2.2V	2.0 PPM			
Output Stability				
Specifications apply for initial stabilizations of two hours, constant ambient temperature of $\pm 1^{\circ}\text{C}$, constant line voltage, constant load, and measurement bandwidth of 0.1 Hz to 1 Hz.				
RANGE	\pm(PPM OF SETTING + FLOOR)			
	10 MINUTES	24 HOURS	30 DAYS*	
0V to 11V	0.2 + 2 μV	0.3 + 3 μV	0.5 + 3 μV	
11V to 22V	0.2 + 3 μV	0.4 + 4 μV	0.5 + 4.5 μV	
22V to 275V	0.3 + 40 μV	0.3 + 50 μV	1.0 + 60 μV	
275V to 1100V	0.3 + 200 μV	0.3 + 200 μV	1.0 + 300 μV	
DIVIDED OUTPUT				
0 mV to 220 mV	0.5 + 0.2 μV	0.5 + 0.2 μV	2 + 0.3 μV	
0.22V to 2.2V	0.5 + 0.2 μV	0.5 + 0.5 μV	2 + 0.7 μV	
*For best results, use internal calibration for periods exceeding one day.				
Temperature Coefficient of Output				
These specifications apply for ambient temperatures outside the $\pm 5^{\circ}\text{C}$ range of the uncertainty specifications listed earlier.				
RANGE	\pm(PPM OF SETTING) PER $^{\circ}\text{C}$			
	0-10$^{\circ}\text{C}$	10-30$^{\circ}\text{C}$	30-40$^{\circ}\text{C}$	40-50$^{\circ}\text{C}$
0V to 11V	0.15 ppm	0.1 ppm	0.4 ppm	1.0 ppm
11V to 22V	0.15 ppm	0.1 ppm	0.4 ppm	1.0 ppm
22V to 275V	0.2 ppm	0.2 ppm	0.6 ppm	1.5 ppm
275V to 1100V	0.2 ppm	0.2 ppm	1.0 ppm	1.5 ppm
DIVIDED OUTPUT				
0-220 mV	0.5 ppm	0.5 ppm	0.5 ppm	1.2 ppm
0.22-2.2V	0.5 ppm	0.5 ppm	0.5 ppm	1.2 ppm

Table 1-3. General Specifications (cont)

LINEARITY			
These specifications apply for the ambient temperature range of 15°C to 30°C within ±5°C of the external calibration temperature.			
RANGE		±PPM OF OUTPUT + MICROVOLTS)	
0 mV to 220 mV		0.5 ppm + 0.2 μ V	
0.22V to 2.2V		0.7 ppm + 0.3 μ V	
0V to 11V		0.5 ppm + 1.5 μ V	
11V to 22V		0.5 ppm	
22V to 275V		0.5 ppm + 40 μ V	
275V to 1110V		1.0 ppm	
RESOLUTION			
RANGE	RESOLUTION	MAXIMUM SETTING	MAXIMUM LOAD OR OUTPUT RESISTANCE
0V to 11V	1 μ V	11.000000V	60 mA
11V to 22V	1 μ V	22.000000V	60 mA
22V to 275V	10 μ V	275.000000V	25 mA
275V to 1100V	100 μ V	1100.0000V	25 mA
DIVIDED OUTPUT			
0 to 220 mV	0.01 μ V	220.00000 mV	495 Ω
0.22V to 2.2V	0.1 μ V	2.2000000V	450 Ω
OUTPUT NOISE			
RANGE	BANDWIDTH		
	0.1 HZ TO 10 HZ	10 HZ TO 10 KHZ	
0 mV to 220 mV	0.1 μ V	5 μ V	
0.22V to 2.2V	0.2 μ V	15 μ V	
0V to 11V	1.5 μ V	30 μ V	
11V to 22V	3.0 μ V	50 μ V	
22V to 275V	35 μ V	150 μ V	
275V to 1100V	100 μ V	300 μ V	
Output Settling Time			
Time to settle within a given uncertainty band of final value, for a change in programmed output within a given range.			
RANGE	±PARTS PER MILLION OF CHANGE*		
	3 SECONDS	5 SECONDS	10 SECONDS
0 mV to 220 mV, 0.22V to 2.2V, 0V to 11V, and 11V to 22V	7 ppm	2 ppm	0.5 ppm
22V to 275V 275V to 1110V	7 ppm	2 ppm	3 ppm
*Add 0.5 seconds for any change in range up to 22V, 1.0 second for a change from 22V up, and 0.5 seconds for a change from STBY to OPER.			

**INTRODUCTION
SPECIFICATIONS**

Table 1-4. Physical and Environmental Specifications

Line Power Requirements			
NOMINAL SETTING	VOLTAGE LIMITS	FUSE	TYPICAL POWER
100V	90-110V	2A/250V	84 watts when in standby at nominal line, 145 watts when in 1100V range 25 mA output and high line
110V	99-121V	2A/250V	
115V	103.5-126.5V	2A/250V	
120V	108-132V	2A/250V	
200V	180-220V	1A/250V	
220V	198-242V	1A/250V	
230V	207-253V	1A/250V	
240V	216-264V	1A/250V	

Line Regulation
Less than ± 0.1 ppm of range for a line voltage change $\pm 10\%$ of nominal.

Temperature and Humidity

CONDITION	TEMPERATURE	% RELATIVE HUMIDITY (NON-CONDENSING)
Non-Operating	-40°C to +75°C 0°C to +50°C	Not controlled $\leq 95\% \pm 5\%$
Operating	0 to 30°C +30 to +40°C +40 to +50°C ²	$\leq 95\% \pm 5\%$ ¹ $\leq 75\% \pm 5\%$ $\leq 45\% \pm 5\%$

Notes: ¹ Accuracy degradation above 80% R.H.
² Instrument accuracy is degraded above 40°C due to loss of oven regulation.

Altitude
Non-Operating 0-12,200m (40,000 feet)
Operating 0-3,050m (10,000 feet)

Vibration

FREQUENCY	FORCE FREQUENCY	DOUBLE AMPLITUDE
5-15 Hz	0.7G at 15 Hz	0.06 in
15-25 Hz	1.3G at 25 Hz	0.04 in
25-55 Hz	3G at 55 Hz	0.02 in

Shock: 18 shocks, 20G, 1/2 sinewaves.
Size: 61cm L x 43cm W x 24cm H (24.0in L x 17.0in W x 8.75in H).
Weight: 30.2 kg (66.4 lb)
Warranty: 1 year, parts and labor (see specific warranty policy).
Compliance with External Standards
ANSI C39.5 Dec 1980
IEC 348 Second Edition 1978
EMI/RFI Review Standards
FCC Rules Part 15, Subpart J
VDE 0871
MIL STD 461B
EMI/RFI Conducted Emissions
VDE 0871
FCC Part 15 J Class
CISPR 11
Radiated EMI/RFI Emissions
Meets or exceeds all VDE and FCC requirements.

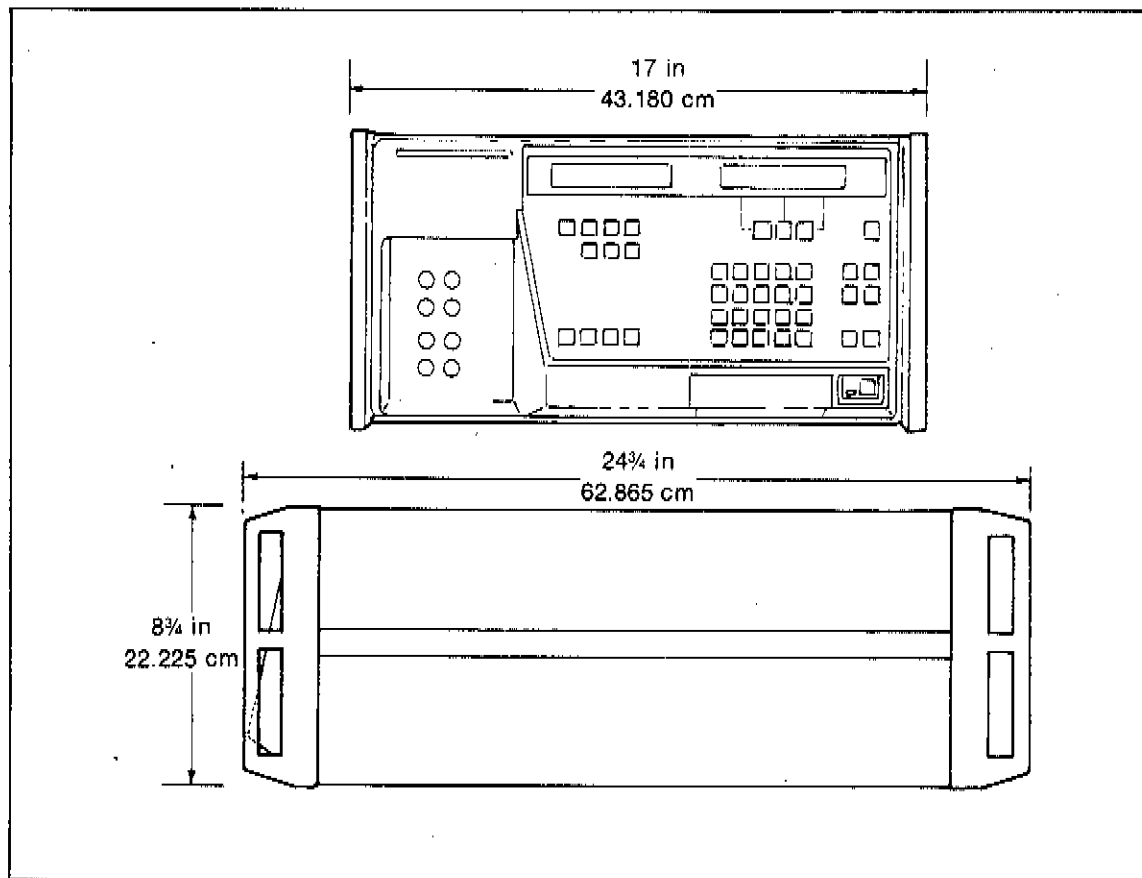

Figure 1-1. Outline Dimensions

INTERPRETING SPECIFICATIONS

1-9.

An industry-wide standard for specifications has not yet been accepted. Therefore, the following paragraphs provide information to help you understand the general specifications in Table 1-3.

Interpreting specifications involves translating the general data provided by the manufacturer (Fluke, in this case) into the specific data you require. The translation process varies according to the type of specifications and the number of independent contributions to the final result. Independent contributions include the range, uncertainty, stability, traceability, etc.

Accuracy and Uncertainty

1-10.

Specifications for calibration instruments include a statement describing their freedom from error, usually expressed as a percentage or absolute value. This freedom from error is frequently expressed as "accuracy." However, a more useful expression of error is "uncertainty," which is the allowed deviation from a known value.

Uncertainty is equal to one minus the percent of accuracy. To illustrate, a soap which is 99.9% pure ("accurate") is 0.1% impure ("uncertain"). Whereas accuracy is typically a large number, uncertainty is typically a small number.

An uncertainty specification can be difficult to interpret because it may be expressed using three different types of statements, which can be combined in several different ways:

INTRODUCTION SPECIFICATIONS

- Percent of output
- Percent of full scale
- Number expressed in units (e.g., microvolts)

Uncertainty specifications are further obscured through the use of various terms like percent or parts per million (or ppm) and the use of various units (like μV).

Absolute Uncertainty

1-11.

Absolute (or "total") uncertainty refers to the deviation of a calibrator's output from a national standard (the national standard volt, in this instance). Absolute uncertainty provides a direct measure of the calibrator's traceability to national standards.

Absolute uncertainty is the combination of two main factors: the uncertainty of the calibrator itself (the relative uncertainty), and the uncertainty of the reference standard used to calibrate the calibrator (the reference standard's traceability). In addition, absolute uncertainty must include the uncertainty added by the calibrator's drift over time (its "stability"), as well as the drift of the reference standard over time.

The 5440 Series Calibrators are normally calibrated with the 732A Direct Voltage Reference Standard. In this case, the absolute uncertainty specifications of the 5440 Series Calibrators must include the uncertainty of the 732A.

Relative Uncertainty

1-12.

Relative uncertainty specifications describe the uncertainty of the calibrator itself. They do not include the uncertainty of the standards used to calibrate the calibrator.

The benefit of relative uncertainty specifications is that they let you calculate a calibrator's absolute uncertainty when the calibrator is calibrated with other than the manufacturers' specified standards. If you use a set of standards different from those recommended by the manufacturer, you will need to know what contribution the standards make to the final specification of absolute uncertainty.

Table 1-3 presents the 5440 Series specifications so that you will easily be able to discern both the absolute and relative specifications of the calibrator, depending on your needs.

Stability

1-13.

Whereas absolute uncertainty refers to the deviation from a national standard, stability refers to the shifts that occur over time. Generally, a good precision source requires good stability.

The 5440 Series has a 30-day stability of $1.5 \text{ ppm} + 3 \mu\text{V}$. This means its uncertainty will not be degraded by more than $\pm(1.5 \text{ ppm} + 3 \mu\text{V})$ over a period of 30 days from the last external calibration, provided the 5-minute Internal Calibration procedure is performed the day of the measurement. The sources of the 5440 Series' stability include their internal reference, d/a converter, and precision dc amplifier.

The stability of the reference standards (e.g., the 732A Reference Standard used to calibrate the 5440 Series) also contribute uncertainty due to their own drift. This uncertainty depends upon the length of time between the calibration of the standard and the use of the standard to calibrate the calibration instrument.

Section 2

Installation and Familiarization

WARNING

THE 5440 SERIES CALIBRATORS ARE CAPABLE OF SUPPLYING LETHAL VOLTAGES. READ THIS SECTION BEFORE OPERATING THE INSTRUMENT.

INTRODUCTION

2-1.

This section provides instructions for installing your Calibrator and introduces you to its operating features. Read this section before operating the instrument or proceeding to the other sections.

UNPACKING AND INSPECTION

2-2.

The Calibrator is shipped in a foam-packed container to prevent damage during shipping. Special instructions for inspection and claims are included in the shipping container. Check the shipping order against the contents of the container and report any damage or shortage to the place of purchase or to the nearest Fluke Technical Service Center. (A list of Fluke Technical Service Centers is located at the back of this manual.) The equipment you should receive with your Calibrator is listed in Table 2-1.

If you need to reship your Calibrator, use the original container. If the original container is not available, a new container can be ordered from Fluke. When ordering a container, please indicate the Calibrator's model and serial number.

PLACEMENT AND RACK-MOUNTING

2-3.

The Calibrator can be used either on your bench or mounted in a standard width, 24-inch deep equipment rack. For bench top use, the Calibrator is equipped with non-marring feet. To rack-mount the Calibrator, use the 5440 Series Rack-Mount Kit, Model M08-205-600. The Rack-Mount Kit includes installation instructions. The 24-inch Rack Slide Kit (M00-280-610) may be used with the Rack Mount Kit for rack slide installations.

CAUTION

Damage caused by overheating will occur if the area around the fan is restricted or the air filter becomes clogged with dust. Keep the area around the fan clear of walls or rack enclosures. Refer to the 5440 Series Service Manual for air filter maintenance procedures.

INSTALLATION AND FAMILIARIZATION
CONNECTING TO LINE VOLTAGE

Table 2-1. Standard Equipment

EQUIPMENT	FLUKE PART NUMBER
Direct Voltage Calibrator	739680 (5440B) or 739698 (5442A)
Line Power Cord	363481
Operator Manual	751966
Service Manual	751974
Getting Started Guide	752014
IEEE-488 Reference Card	752006
Certificate of Calibration	No part number

CONNECTING TO LINE VOLTAGE **2-4.**

The Line Power Label on the rear panel of your Calibrator shows the instrument's line voltage range as it was set at the factory. It also gives the correct fuse rating for that voltage. Your Calibrator arrives from the factory with the line voltage specified at the time of purchase.

Line Voltage Selection **2-5.**

You can set the Calibrator to operate from eight different line voltages (from 50 Hz to 60 Hz). The line voltage selection is set using three switches located inside the Calibrator. To change the line voltage setting, refer to the 5440 Series Service Manual.

Ground Connection **2-6.**

WARNING

TO AVOID SHOCK HAZARD OR INSTRUMENT DAMAGE, CONNECT THE CALIBRATOR LINE POWER GROUND TO EARTH GROUND. THE CONNECTION CAN BE MADE BY USING THE FACTORY-SUPPLIED, THREE-CONDUCTOR LINE POWER CORD. DO NOT USE A TWO-CONDUCTOR EXTENSION CORD; THIS WILL BREAK THE GROUND CONNECTION.

To correctly ground the Calibrator, use the factory-supplied, three-conductor line power cord. Do not use two-conductor line power cords in the power line (e.g., a two-wire extension cord), as this will create a safety hazard.

Fuse Replacement **2-7.**

The required current rating of the input line power fuse depends on the line voltage setting of your Calibrator. Fuse ratings are listed in Table 2-2 for each voltage setting. The line fuse rating is also given on the rear panel Line Power Label.

FRONT AND REAR PANEL FEATURES **2-8.**

Front panel controls, indicators, and connectors are shown in Figure 2-1 and are described in Table 2-3. The front panel keys are described in the following headings.

Rear panel controls, indicators, and connectors are shown in Figure 2-2 and are described in Table 2-4. Changing from front to rear terminals requires an internal operation; refer to the 5440 Series Service Manual for instructions. (The REAR ANALOG OUTPUT terminals are optional on the 5442A.)

INSTALLATION AND FAMILIARIZATION
FRONT AND REAR PANEL FEATURES

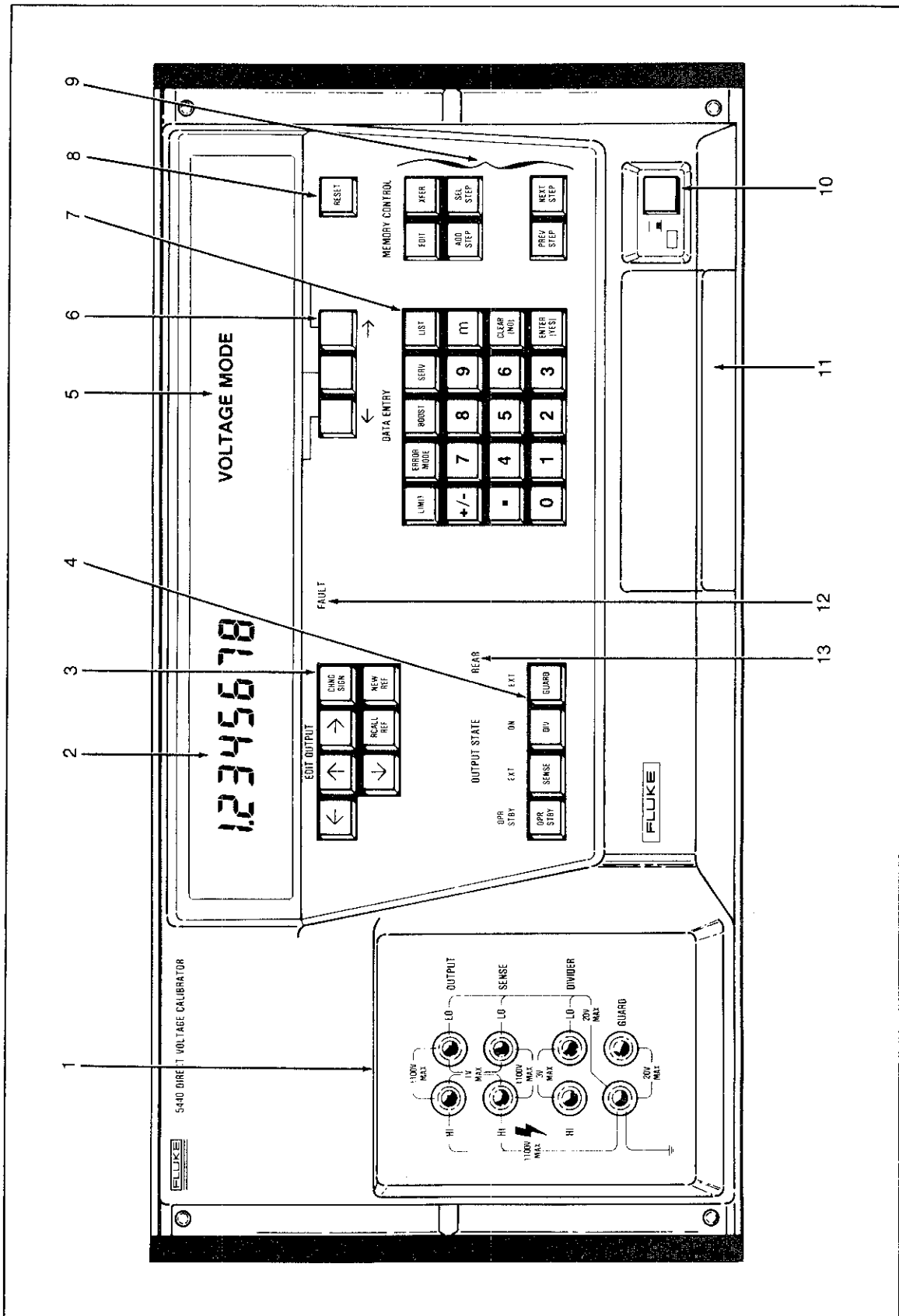

Figure 2-1. Front Panel Controls, Indicators, and Connectors

INSTALLATION AND FAMILIARIZATION
FRONT AND REAR PANEL FEATURES

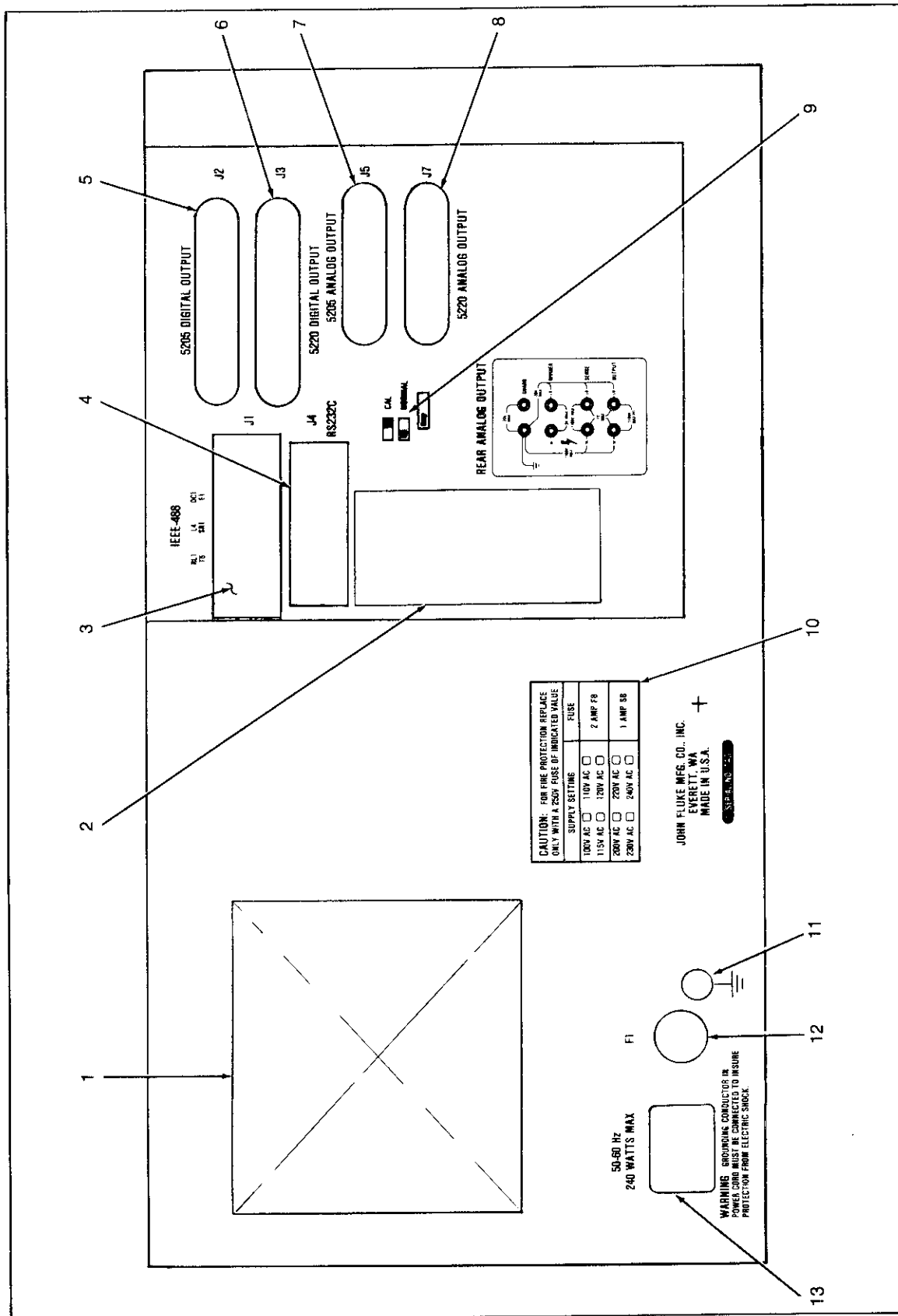

Figure 2-2. Rear Panel Controls, Indicators, and Connectors

INSTALLATION AND FAMILIARIZATION
FRONT AND REAR PANEL FEATURES

Table 2-2. Line Fuse Values

LINE VOLTAGE	FUSE VALUE
100V	AGC 2 A
110V	AGC 2 A
115V	AGC 2 A
120V	AGC 2 A
200V	MDX 1 A
220V	MDX 1 A
230V	MDX 1 A
240V	MDX 1 A

Table 2-3. Front Panel Controls, Indicators, and Connectors

ITEM	NAME	DESCRIPTION
1	Output Terminals	Binding post connectors for calibration connections.
	OUTPUT	Connectors for output voltages from -1100V to +1100V. (Enabled when the OPR indicator is on and the DIV indicator is off.)
	SENSE	Connectors for sensing at the load when external sense is selected (EXT indicator on above SENSE key). Disabled when internal sense is selected (EXT indicator off above SENSE key).
	DIVIDER	Connectors for high-resolution output voltages between +2.2V and -2.2V. Enabled when the OPR indicator is on and the Divider feature is selected (DIV indicator on). High output impedance (450Ω on the 2V range, 495Ω on the 0.2V range).
	GUARD	Connector for the internal guard.
	GROUND	Connector for earth (chassis) ground.
2	Output Display	An eight-digit, vacuum-fluorescent display with unit annunciators and a bright-digit cursor. In Voltage Mode, the display shows the voltage present at the source terminals when OPR (operate) is selected. In Boost operation, the display shows the output of the boost instrument.
3	EDIT OUTPUT Keys	Seven keys used to edit the output shown on the Output Display. Also used to store or recall the reference value which is used in Error Mode to calculate UUT error. Normally used with Error Mode.
	← →	Moves the bright-digit cursor left or right.
	↑ ↓	Increments or decrements the value of the bright digit. Press and hold to repeat.
	CHGN SIGN	Toggles the polarity of the output.
	RCALL REF	Recalls the stored Error Mode reference value.
	NEW REF	Stores the displayed output value as the new Error Mode reference value.

INSTALLATION AND FAMILIARIZATION
FRONT AND REAR PANEL FEATURES

Table 2-3. Front Panel Controls, Indicators, and Connectors (cont)

ITEM	NAME	DESCRIPTION
4	<p>OUTPUT STATE Keys and Indicators</p> <p>OPR/STBY</p> <p>SENSE</p> <p>DIV</p> <p>GUARD</p>	<p>Four keys which control the state of the output terminals. The indicators above the keys show the states selected.</p> <p>Toggles the output state between Standby (STBY indicator on) and Operate (OPR indicator on). The selected output voltage is not applied to the output terminals until Operate is selected. The default state is Standby.</p> <p>Toggles between external sense (EXT indicator on) and internal sense (EXT indicator off). See description of SENSE terminals.</p> <p>Toggles the Divider feature on or off. Used for high resolution at low voltages. When the Divider feature is selected (DIV indicator lit) and the OPR indicator is lit, the output voltage appears at the DIVIDER terminals instead of the OUTPUT terminals. The selected output must be between -2.2V and 2.2V.</p> <p>Toggles between internal and external guard. In internal guard (the normal condition), the GUARD terminal is internally connected to OUTPUT LO. In external guard (EXT indicator on), the GUARD terminal is disconnected from OUTPUT LO to allow for external guard connection.</p>
5	Alphanumeric Display	<p>A vacuum-fluorescent dot matrix display, with two lines of 20 characters each. Used to display four types of messages (examples are shown in Figure 2-3):</p> <ol style="list-style-type: none"> 1. Activity in Progress. Indicates Voltage Mode, Internal Calibration steps, etc. 2. Soft Key Labels. Displays menu choices which can be selected by pressing the soft keys directly below the Alphanumeric Display. 3. Digit Entry Prompt. Displays the present value of internal parameters and prompts you to enter new numeric values. 4. Error Message. Shows that an error has occurred and gives instructions when appropriate.
6	Soft Keys	<p>Three unlabeled keys used to select menu choices and set internal parameters. Menu choices are displayed in the Alphanumeric Display by pressing the LIMIT, ERROR MODE, SVCE, or LIST keys (and the BOOST, EDIT, or XFR keys on the 5440B.) Pressing the soft key directly below a menu choice selects that choice. When a cursor is displayed in the Alphanumeric Display, pressing the soft keys moves the cursor.</p>
7	DATA ENTRY Keys	<p>The top row of keys are used to select soft-key menus. The other 15 keys are keys used to enter data and select menus. (The BOOST key is unlabeled on the 5442A and has no function.)</p>

Table 2-3. Front Panel Controls, Indicators, and Connectors (cont)

ITEM	NAME	DESCRIPTION
8	RESET Key	Sets the Calibrator to the power-up default state. The key can be used during front panel operation and remote operation.
9	MEMORY CONTROL Keys (5440B Only)	Six keys used to store and edit sequences of Calibrator settings ("procedures").
	EDIT	Selects a soft-key menu for editing the procedure stored in internal memory.
	XFR	Selects a soft-key menu for transferring a procedure between internal memory and the Procedure Storage Module.
	ADD STEP	Adds the present setting as the last step in the procedure stored in internal memory.
	SEL STEP	Prompts for and recalls a step from internal memory.
	NEXT STEP	Recalls the first step from internal memory. When pressed again, recalls the next step.
	PREV STEP	Calls up the previous step from internal memory.
10	POWER	Push-on, push-off switch used to apply line power to the Calibrator. The indicator is lit when power is on.
11	Procedure Storage Module (5440B Only)	Provides non-volatile storage of up to 60 Calibrator settings.
12	FAULT Indicator	When on, indicates the Calibrator is not operational.
13	REAR Output Indicator	When on, shows that the Calibrator has been set to provide its output voltage to the REAR ANALOG OUTPUT terminals (optional on the 5442A).

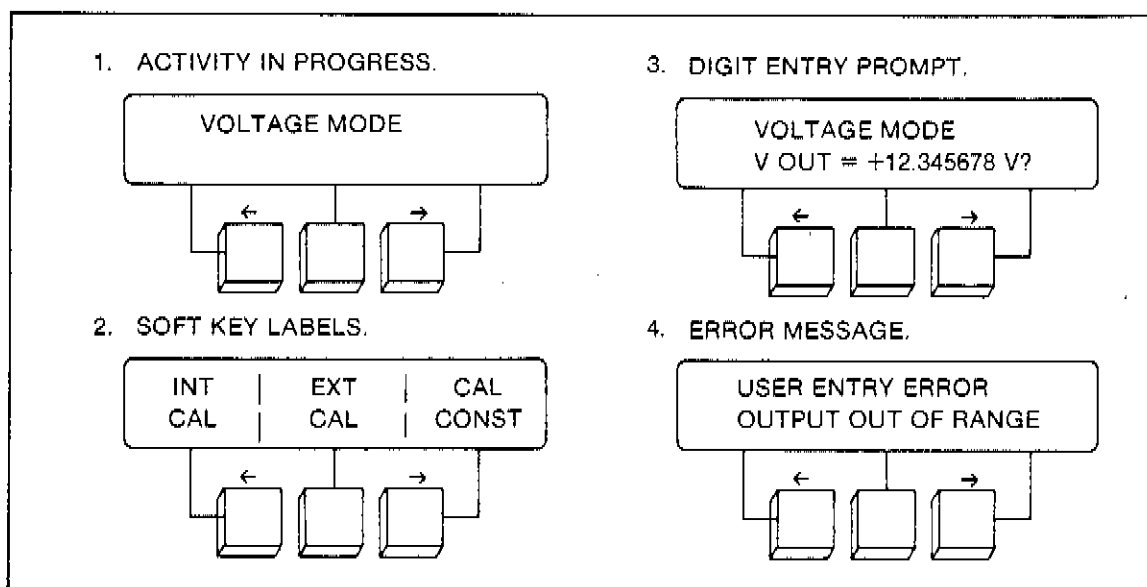

Figure 2-3. Alphanumeric Display Examples

INSTALLATION AND FAMILIARIZATION
FRONT AND REAR PANEL FEATURES

Table 2-4. Rear Panel Controls, Indicators, and Connectors

ITEM	NAME	DESCRIPTION
1	Air Filter and Fan	The fan provides a constant, cooling airflow to the Calibrator. The air filter ensures that the airflow is free from dust and debris.
2	REAR ANALOG OUTPUT Terminals	Provides all the functions of the front panel output terminals. The Calibrator must be internally configured to select either front or rear outputs. (See Section 3.) The front and rear outputs are mutually exclusive. (The rear outputs are optional on the 5442A.)
3	IEEE-488 Connector, J1	Standard IEEE-488 interface connector. Refer to Section 4 for information on how to make connections to the IEEE-488 bus.
4	RS-232-C Connector, J4	Female RS-232-C connector with covered housing.
5	5205A Digital Connector, J2 (5440B only)	Precision Power Amplifier cable connector for digital signals. Used during Voltage Boost operation.
6	5220A Digital Connector, J3 (5440B only)	Transconductance Amplifier cable connector for digital signals. Used during Current Boost operation.
7	5205A Analog Connector, J5 (5440B only)	Precision Power Amplifier cable connector for analog signals. Used during Voltage Boost operation.
8	5220A Analog Connector, J7 (5440B only)	Transconductance Amplifier cable connector for analog signal. Used during Current Boost operation.
9	CAL/NORMAL Switch	Enables or disables the External Calibration capability of the Calibrator. Normally disabled and sealed.
10	Line Power Label	Shows the factory-set line voltage and appropriate fuse rating for your Calibrator.
11	Earth Ground Connector	A screw post and knurled nut for connecting the chassis to earth ground. (The chassis is normally connected to the earth ground by the three-conductor line power cord.)
12	F1 (Fuse Holder)	Line power fuse holder. Refer to the Line Power Label for fuse ratings.
13	Line Power Connector	Three prong connector for the line power cord.
-	RS-232-C Shorting Plug	Allows you to reconfigure the RS-232-C port using jumpers. (Refer to Section 5 for instructions.) The plug is accessible when the I/O cover plate is removed.

The POWER Key

2-9.

The POWER key turns on the Calibrator. At power-up, the Calibrator assumes the default settings shown in Table 2-5.

The OUTPUT STATE Keys

2-10.

The four front panel OUTPUT STATE keys are OPR/STBY, SENSE, DIV, and GUARD. These keys control the state of the output terminals, as the following paragraphs explain.

OPR/STBY

2-11.

WARNING

HAZARDOUS VOLTAGE MAY EXIST AT THE OUTPUT AND SENSE TERMINALS FOR UP TO 3 SECONDS AFTER THE CALIBRATOR IS SWITCHED FROM OPR TO STBY. USE CAUTION TO AVOID ELECTRIC SHOCK OR EQUIPMENT DAMAGE.

The OPR/STBY key toggles the state of the output source terminals (the OUTPUT or DIVIDER terminals) between operate (OPR) and standby (STBY). When OPR is selected, the Calibrator applies its output voltage to the output source terminals. When STBY is selected, the front panel SENSE HI and OUTPUT HI terminals are disconnected from active internal circuitry. The indicators above the OPR/STBY key indicate the selected state.

In STBY, the output source terminals are still internally connected to a 1 μ F capacitor in parallel with a 1 M Ω resistor. Therefore, during high-voltage operation, the output voltage may take up to three seconds to drop to a safe level after the Calibrator has been placed in STBY.

STBY is selected when the Calibrator is first powered-up or reset. For safety, the Calibrator also trips to STBY when a voltage is selected above 22V (or below -22V) if the Calibrator was previously set to a voltage between -22V and 22V.

SENSE

2-12.

The SENSE key toggles between internal and external sensing. Internal sensing is used for two-wire calibration connections; external sensing is used for four-wire calibration connections.

Table 2-5. Power-Up Default Settings

PARAMETER	VALUE/STATUS
Output Voltage	0 mV dc
Error Mode Reference	0 mV dc
Voltage Limits	+1100V dc, -1100V dc
Current Limits	\pm 65 mA
Tolerance	0% of Reading
	0 μ V Floor
Instrument Status	Voltage Mode
	Standby
	Internal Sensing
	Divider Feature OFF
	Error Mode OFF

INSTALLATION AND FAMILIARIZATION

FRONT AND REAR PANEL FEATURES

When internal sensing is selected, the SENSE terminals are disabled. When external sensing is selected, a special sensing circuit in the Calibrator compensates for lead losses. This proprietary circuit is called High-Impedance Sensing (HZs™) and it corrects for up to 2Ω in the sense leads. External sensing is indicated by the EXT indicator above the SENSE key.

DIV

2-13.

The DIV key toggles the Divider feature on and off. The Divider feature provides high-resolution, low-noise output voltages between -2.2V and +2.2V.

When the DIV indicator is off, normal output voltages are directed to the OUTPUT terminals. When the DIV indicator is on, output voltages are directed to the DIVIDER terminals. The DIVIDER terminals use an internal 10:1 and 100:1 voltage divider to improve the resolution and noise characteristics of the Calibrator. The output impedance of the DIVIDER terminals is about 500Ω.

The Divider feature is discussed in detail in Section 3 under the heading, "Selecting a Divided Voltage Output." Divider connections are explained later in this section.

GUARD

2-14.

The GUARD key toggles the GUARD terminal between internal and external guard. When external guard is selected, the EXT indicator is lit above the GUARD key.

The GUARD terminal is connected to the internal chassis guard. In internal guard (the normal condition), the GUARD is internally connected to the OUTPUT LO terminal to provide shielding against electrostatic interference.

External guard is used to prevent error caused by ground loops. In external guard, the GUARD terminal is disconnected from the OUTPUT LO terminal and left floating to allow for external connection. External guard connections are explained later in this section.

The Soft Keys and Menus

2-15.

The soft keys are used with the dark-grey keys shown in Figure 2-4 to select operating features in the Calibrator. Pressing any one of the keys in Figure 2-4 causes a menu to be displayed in the Alphanumeric Display. Menu choices can then be selected by pressing the "soft keys", the three dark-grey keys below the Alphanumeric Display. Pressing the soft key directly below a menu choice selects that choice.

The menus that can be called up are illustrated in Figure 2-5. Note that some menu choices call up additional menus, which present additional choices. Soft key operations are explained in detail in Section 3.

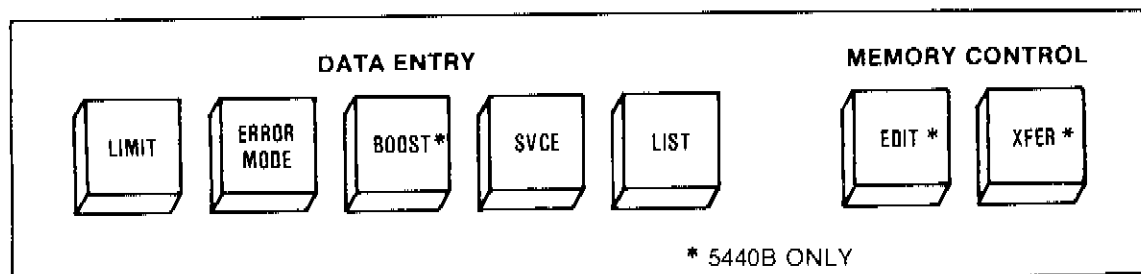
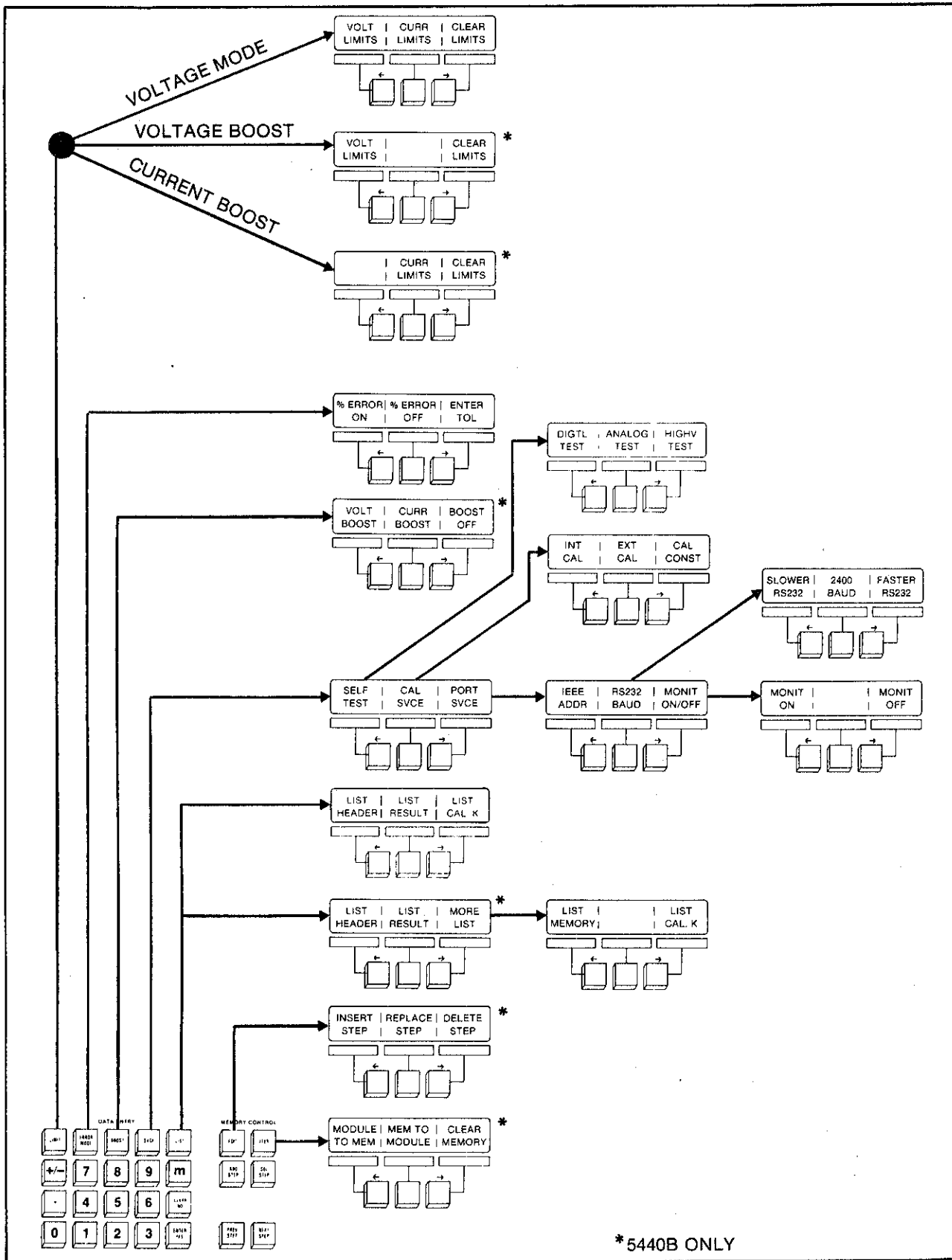

Figure 2-4. Keys Which Call Up Soft-key Menus

INSTALLATION AND FAMILIARIZATION
FRONT AND REAR PANEL FEATURES



* 5440B ONLY

Figure 2-5. Soft Keys

INSTALLATION AND FAMILIARIZATION

FRONT AND REAR PANEL FEATURES

Note that the BOOST key on the 5440B is replaced by a blank key on the 5442A. This blank key has no function in the 5442A; pressing it causes the 5442A to display the message, "FUNCTION NOT IMPLEMENTED".

The DATA ENTRY Keys

2-16.

The DATA ENTRY keys have two functions. The top, dark-grey row of keys is used to select soft-key menus. The other keys are used to set the output voltage and other parameters, such as voltage and current limits or the RS-232-C baud rate.

The white DATA ENTRY keys are used to enter numeric values. As keys are pressed, the corresponding value is displayed on the Alphanumeric Display. (The "m" key toggles the displayed units multiplier, when applicable.) The ENTER(YES) key selects the displayed value as the new parameter. (In Voltage Mode, the ENTER(YES) key also stores this value as the reference which is used in Error Mode to calculate the error of the unit under test). The ENTER(YES) key is also used to answer "yes" when the Alphanumeric Display prompts for verification or operator action.

The CLEAR(NO) key cancels the numeric keyboard entry. It also answers "no" to prompts and clears error messages and menus from the Alphanumeric Display.

The EDIT OUTPUT Keys

2-17.

The EDIT OUTPUT keys are normally used in conjunction with the Error Mode feature. The Error Mode feature calculates and displays the error of the unit under test (UUT) relative to a stored reference value.

The EDIT OUTPUT keys are used to change the value of the Calibrator output. The output is usually edited so that the UUT displays the nominal calibration value. The EDIT OUTPUT keys are also used to recall or set a new reference value against which the UUT reading is compared. The Error Mode feature is explained in more detail in Section 3 under the heading, "Displaying UUT Error."

The MEMORY CONTROL Keys (5440B Only)

2-18.

The MEMORY CONTROL keys let you save front panel Calibrator settings for quick recall at a later time. The settings are saved as a "procedure," which consists of a numbered sequence of steps. Each step contains the output value, test mode, output state, voltage/current/tolerance limits, and Error Mode information. As a procedure is created, it is stored in internal memory. The procedure may then be transferred to the non-volatile memory in the Procedure Storage Module.

Operation of the MEMORY CONTROL keys is explained in detail in Section 3 under the headings, "Creating and Editing Procedures" and "Storing Procedures."

The RESET Key

2-19.

The RESET key initializes the Calibrator to its power-up default settings. The key also aborts tasks such as External Calibration, Internal Calibration, self-testing, printing, etc. The RESET key does not modify the procedure stored in internal memory. When the RESET key is pressed, your instrument's model number (5440B or 5442A) and software version level flashes on the Alphanumeric Display.

CALIBRATION CONNECTIONS

2-20.

WARNING

THE 5440 SERIES CALIBRATORS ARE CAPABLE OF SUPPLYING LETHAL VOLTAGES. AVOID MAKING CONNECTIONS TO THE OUTPUT TERMINALS WHEN ANY VOLTAGE IS PRESENT. PLACING THE INSTRUMENT IN STANDBY MAY NOT BE ENOUGH TO AVOID SHOCK HAZARD, SINCE THE OPR/STBY BUTTON MAY BE PRESSED ACCIDENTALLY. SET THE OUTPUT FOR ZERO VOLTS AS WELL AS TO STANDBY BEFORE CHANGING CONNECTIONS.

The Calibrator has two types of outputs. In the Voltage Mode, the Calibrator output is a dc voltage at the OUTPUT terminals (or at the DIVIDER terminals if the Divider feature is selected). In Boost operation, the Calibrator output is a dc reference voltage used to drive a boost instrument; the Calibrator's reference voltage output appears at the 5205A or 5220A Analog Connectors on the rear panel.

The following paragraphs discuss considerations regarding Voltage Mode connections. Boost operation connections are discussed in Section 3 under the heading, "Selecting a Boost Output."

Recommended Cable and Connector Types

2-21.

Calibration connections may be made to the output terminals using banana-type connectors, terminal lugs, or bare wire. (Bare wire is not recommended due to shock hazard.) To avoid errors due to thermovoltic voltages (thermal emfs), use conductors and connectors made of copper or materials that generate small thermal emfs when joined to copper. Avoid using nickel-plated connectors. Optimum connections may be made using the Fluke 5440A-7002 Low Thermal EMF Plug-In Cables, which are constructed with well-shielded copper wire and copper connectors.

OUTPUT and DIVIDER Connections

2-22.

In the Voltage Mode, the input of the unit under test (UUT) is normally connected to the Calibrator's OUTPUT terminals. For high-resolution voltages between $-2.2V$ and $+2.2V$, using the DIVIDER feature, the UUT is connected instead to the Calibrator's DIVIDER terminals.

SENSE Connections

2-23.

CAUTION

To prevent loss of regulation and possible damage to the Calibrator, ensure that the polarity of the SENSE terminals is correct when connecting them to the load.

When the Calibrator is used with low-impedance UUTs, a voltage drop occurs across the test leads which can cause significant error. This error can be eliminated by using the Calibrator's external sense feature.

Low-impedance UUTs, including some digital voltmeters, can draw enough current to affect the accuracy of voltages presented to the load. Consider the fact that typical test leads of AWG-20 wire have a lead resistance of 12 milliohms per foot, or a total of 72 milliohms for a pair of leads 3-feet long. To limit the lead drop error to less than 0.1 ppm, it is necessary that the lead resistance be greater than 10 million times the resistance of the test leads, or greater than 720 k Ω .

INSTALLATION AND FAMILIARIZATION

CALIBRATION CONNECTIONS

When the Calibrator is used with high-impedance UUTs, the test leads cause no appreciable error. In such cases, connect the UUT to the Calibrator with a single pair of leads and set the Calibrator to internal sense (EXT indicator off).

When using the Calibrator with low-impedance UUTs, connect one pair of test leads between the Calibrator's OUTPUT terminals and the UUT terminals, and a second set of test leads between the Calibrator's SENSE terminals and the UUT terminals. (See Figure 2-6.) **USE CARE TO OBSERVE THE SAME POLARITY FOR OUTPUT AND SENSE LEADS.** Then toggle the Calibrator's SENSE key to external sense (EXT indicator on).

NOTE

The external sense feature (and consequently, the SENSE terminals) cannot be used with DIVIDER output voltages. Attempting to do so will degrade the accuracy of the DIVIDER output.

GUARD Connections

2-24.

The Calibrator has an internal guard circuit to shield the Calibrator's circuitry from electrostatic interference. To provide this shielding, the guard circuit (which is accessible at the GUARD terminal) must be connected to the OUTPUT LO terminal.

The guard circuit can be connected to the OUTPUT LO terminal either internally or externally. How the connection is made depends whether the UUT has floating or grounded inputs.

Internal Guard Connections

2-25.

When calibrating UUTs with floating inputs, the guard circuit should be connected internally. The following configuration usually gives the best results:

1. Toggle the GUARD key to internal guard (EXT indicator off). This internally connects the GUARD terminal to the OUTPUT LO terminal.

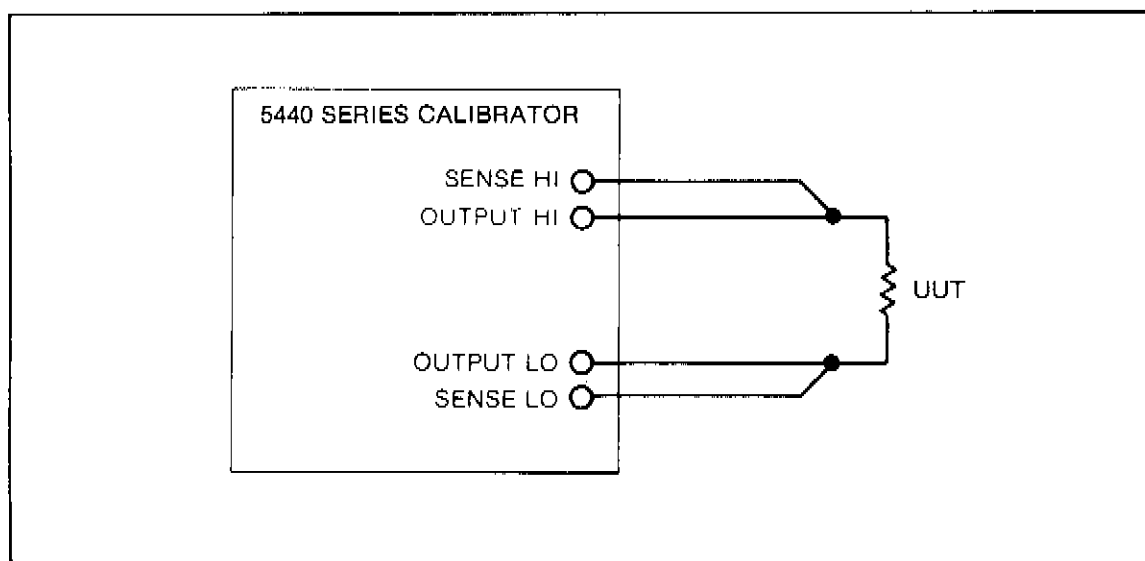

Figure 2-6. External Sense Connections

2. Connect the shorting link between the chassis GROUND terminal and the GUARD terminal. The Calibrator is shipped with a shorting link in this configuration.

External Guard Connections

2-26.

When calibrating a UUT with a grounded input, the guard circuit should be connected externally to avoid errors due to ground current loops. This connection is made as follows:

1. Toggle the GUARD key to external guard (EXT indicator on). This internally disconnects the GUARD terminal from the OUTPUT LO terminal.
2. Remove the shorting link between the GUARD terminal and the GROUND terminal on the Calibrator.
3. Connect the GUARD terminal on the Calibrator to the low terminal on the UUT.

Ground current loops occur when a difference in potential exists between the line power ground of the UUT and line power ground of the Calibrator. If the guard was connected internally to the OUTPUT LO terminal, the difference in potentials would cause a circulating ground current to flow in the lead connecting the Calibrator OUTPUT LO terminal to the low terminal of the UUT. This current could cause errors in the Calibrator output voltage.

The external guard connection eliminates this problem by establishing a direct connection between the Calibrator guard and the ground on the UUT, which eliminates the ground current in the low lead connecting the two instruments. This configuration is illustrated in Figure 2-7.

CHANGING FROM FRONT TO REAR OUTPUTS

2-27.

The rear panel analog output terminals (standard on the 5440B and optional on the 5442A) duplicate all of the front panel terminals and provide for banana-plug connections. The Calibrator can be internally configured for use with either the front or rear panel terminals. The 5440B is configured at the factory for use with the front panel terminals.

NOTE

The Rear Panel Output Option for the 5442A (5442A-01) must be installed at a Fluke Service Center.

To configure the Calibrator for rear analog output connections, proceed as follows:

WARNING

TO AVOID ELECTRICAL SHOCK, DISCONNECT ALL POWER FROM THE CALIBRATOR BEFORE OPENING THE INSTRUMENT CASE. WAIT 4 SECONDS FOR ANY OUTPUT VOLTAGE TO DECAY. USE CAUTION TO AVOID SHOCK FROM ANY CHARGE STORED IN THE POWER SUPPLY.

INSTALLATION AND FAMILIARIZATION
INSTRUMENT MESSAGES

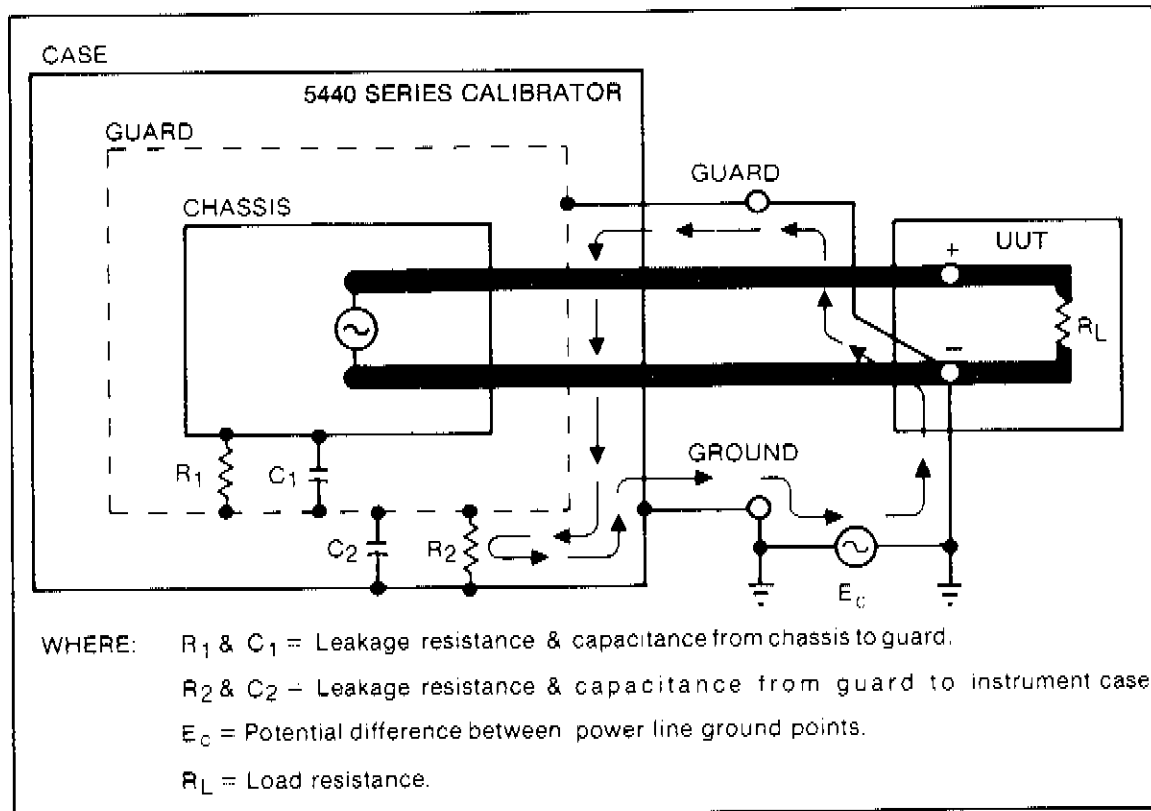

Figure 2-7. Proper External Guard Connections

1. Disconnect the line power cord from the Calibrator.
2. Remove the top outer cover from the instrument. (Three screws are located along the front edge and five screws are located along the back edge.)
3. Remove the top inner cover by removing the four screws from each side.
4. Remove the A4 Output Printed Circuit Assembly (PCA) from motherboard connectors J9, J0, and J11, pulling the PCA by its card extractors. (See Figure 2-8.)
5. Insert the A4 Output PCA into the adjacent card slot towards the rear. (The slot is labeled REAR OUTPUT, and has connectors J12, J13, and J14.) Press the PCA firmly into the motherboard connectors.
6. Reinstall the top inner and outer covers.

INSTRUMENT MESSAGES

2-28.

The Calibrator has extensive diagnostic and monitoring capabilities. Any time an error or other fault condition is detected, the Calibrator displays a message in the Alphanumeric Display. Table 2-7 lists the messages that can be caused by operator error either from the front panel or over the IEEE-488 interface.

The top line of a message typically indicates the general type of error or fault. The second line typically indicates more specific information or suggests a course of action. Pressing any key clears the message from the display.

You may be able to perform some routine service procedures yourself, rather than returning the Calibrator to a Service Center. Refer to the 5440 Series Service Manual.

SERVICE INFORMATION

2-29.

Every Fluke 5440 Series Direct Voltage Calibrator is warranted for a period of 1 year from the date of delivery to the original purchaser. The warranty is located at the front of this manual.

Factory-authorized service, including calibration, is available at Fluke Technical Service Centers. A list of Technical Service Centers is provided at the back of this Manual.

For in-warranty service and/or calibration, return your Calibrator to the nearest Technical Service Center. For instruments that are beyond the warranty period, an estimate of the repairs will be provided on request.

Fluke also has a Module Exchange Program to speed service. Your Fluke Sales Engineer can give you more information on the program. The program is currently limited to the continental United States.

You may be able to perform some routine service procedures yourself, rather than returning the Calibrator to a Service Center. Refer to the 5440 Series Service Manual.

INSTALLATION AND FAMILIARIZATION
CHANGING FROM FRONT TO REAR TERMINALS

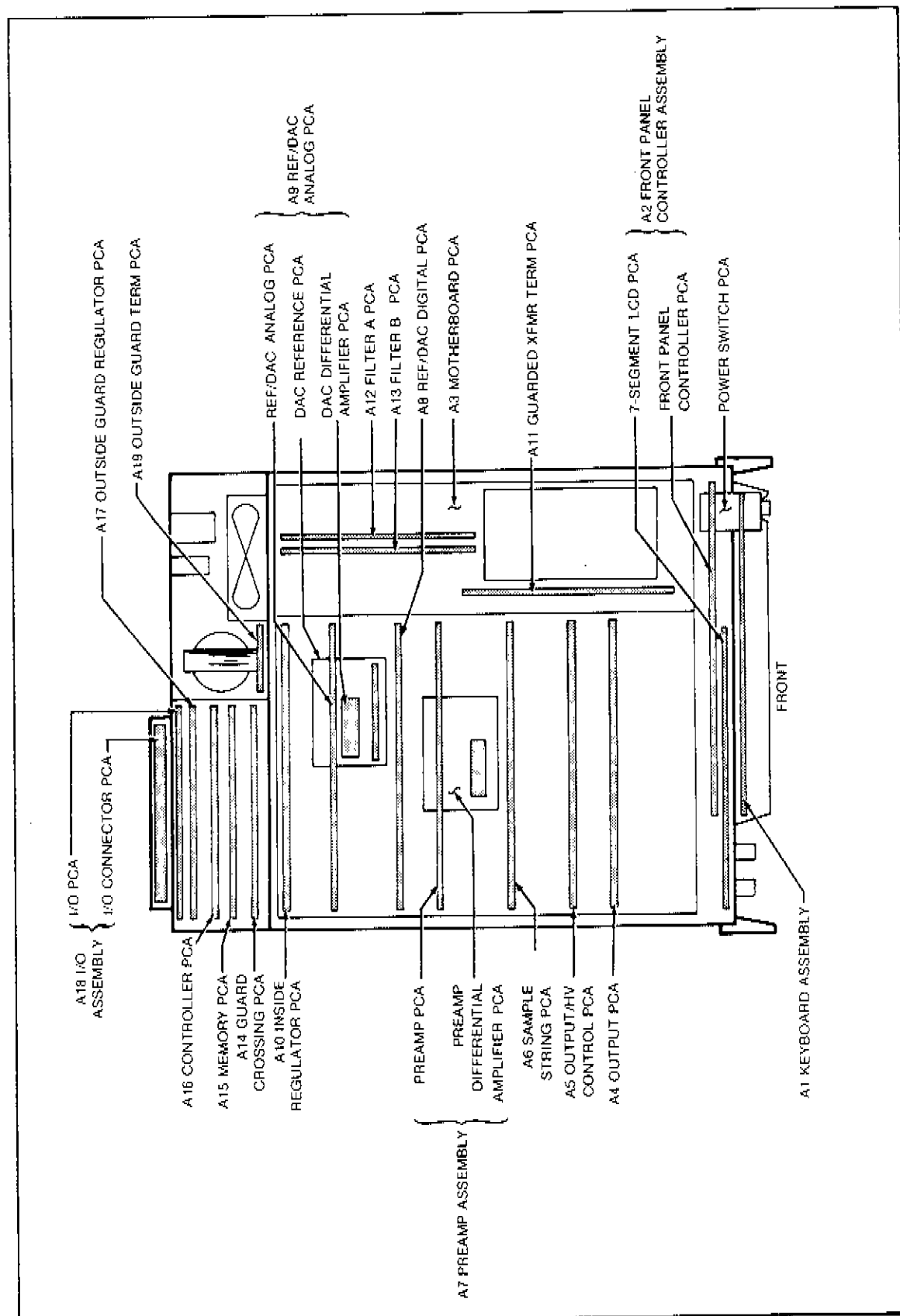

Figure 2-8. Changing from Front to Rear Terminals

Table 2-6. Instrument Messages

5440 SERIES MESSAGE		COMMENTS
ALPHANUMERIC DISPLAY	IEEE-488 REPORT	
BOOST INTERF ERROR CHECK REAR CONNECTOR	144	The wrong type instrument is connected to the Boost Interface.
BOOST INTERF ERROR MISSING REAR CABLE	145	No instrument is connected to the Boost Interface.
BOOST INTERF ERROR VOLTAGE TRIP	146	Voltage boost trip.
BOOST INTERF ERROR CURRENT TRIP	147	Current boost trip.
IEEE488 REMOTE ERROR SOURCE HANDSHAKE	152	IEEE-488 interface source handshake error.
IEEE488 REMOTE ERROR EXPECTING TERMINATOR	153	IEEE-488 interface terminator error. The Calibrator received a carriage return (CR) without a line feed (LF).
IEEE488 REMOTE ERROR EXPECTING SEPARATOR	154	IEEE-488 interface separator error. The Calibrator received a Statement from which a separator was missing.
IEEE488 REMOTE ERROR EXPECTING HEADER	155	IEEE-488 interface header error. The Calibrator received a Statement with an invalid header.
IEEE488 REMOTE ERROR EXPECTING NUMBER	156	IEEE-488 interface numeric error. The Calibrator received a statement with an invalid numeric string.
IEEE488 REMOTE ERROR BUFFER OVERFLOW	157	IEEE-488 interface buffer overflow. The Calibrator received a Statement with more than 127 characters.
IEEE488 REMOTE ERROR BAD CHARACTER	158	IEEE-488 interface character error. The Calibrator received an invalid character.
RS232C SERIAL ERROR	160	The printer port handshake timed out. This means that the handshake on the RS-232-C interface was not completed.
USER ENTRY ERROR NUMBER OUT OF RANGE	168	A numeric parameter entered at the front panel was not within the allowable range for that parameter.
USER ENTRY ERROR OUTPUT OUT OF RANGE	169	An output was entered at the front panel that was not within the output entry limits for that operating mode.
USER ENTRY ERROR LIMITS OUT OF RANGE	170	A limit was entered at the front panel that was not within the allowable maximums and minimums for that limit.
USER ENTRY ERROR DIVIDER OUT OF RANGE	171	The DIV (OUTPUT STATE) key was used incorrectly.

**INSTALLATION AND FAMILIARIZATION
INSTRUMENT MESSAGES**

Table 2-6. Instrument Messages (cont)

5440 SERIES MESSAGE		COMMENTS
ALPHANUMERIC DISPLAY	IEEE-488 REPORT	
USER ENTRY ERROR IN OUTPUT TERMINAL	172	The SENSE OUTPUT STATE key was used incorrectly.
USER ENTRY ERROR IN OUTPUT TERMINAL	173	The GUARD OUTPUT STATE key was used incorrectly.
USER ENTRY ERROR INSTRUMENT IS BUSY	175	A command was entered, from the front panel, that is not allowed in the present instrument state.
STORAGE MODULE ERROR CANNOT READ MODULE	None	Data could not be read from the Procedure Storage Module.
STORAGE MODULE ERROR CANNOT WRITE MODULE	None	Data could not be written into the Procedure Storage Module.
SEQUENCING ERROR MUST XFR MOD TO MEM	None	There is no test sequence in sequence memory.
SEQUENCING ERROR NO SUCH STEP NUMBER	None	The step number selected is not in sequence memory.
SEQUENCING ERROR SEQ MEMORY IS FULL	None	Sequence memory is full.
SEQUENCING ERROR BAD STEP IN SEQ MEM	None	There is a bad step in sequence memory.

Section 3

Front Panel Operation

INTRODUCTION

3-1.

This section presents instructions for operating the Calibrator from the front panel. Preliminary information regarding power-up, warm-up, and calibration is followed by instructions for each type of operation that can be performed. For reference, the types of operations are summarized in Table 3-1. Soft key operations are summarized in Table 3-2. For a description of the Calibrator's controls, indicators, and connectors, refer to Section 2.

WARNING

BEFORE OPERATING THE CALIBRATOR, FIRST READ SECTION 2 TO ENSURE THE CALIBRATOR IS SAFELY GROUNDED AND CORRECTLY INSTALLED.

PRELIMINARY PROCEDURES

3-2.

The following paragraphs provide information about procedures which should be performed before operating the Calibrator.

Power-Up

3-3.

When the Calibrator is powered-up, all front-panel indicators light up (except for the FAULT indicator), and the three microprocessors in the instrument perform a quick self-test. The indicators then turn off and the display segments light up. About a second later, the rear microprocessor becomes operational and only the STBY indicator remains lit, indicating the Calibrator is in Standby. The Output Display shows "+00000.000mV", and the Alphanumeric Display shows "VOLTAGE MODE".

Table 3-1. Summary of Operations

OPERATION	PARAGRAPH
Preliminary Procedures	3-2
Selecting a Voltage Output	3-7
Selecting a Divided Voltage Output	3-10
Displaying UUT Error	3-13
Setting Output Limits	3-17
Selecting a Boost Output (5440B Only)	3-21
Setting Communication Parameters	3-24
Printing Data	3-25
Performing Self-Tests	3-30
Creating and Editing Procedures (5440B Only)	3-34
Storing Procedures (5440B Only)	3-43
External Calibration Procedure	3-46

FRONT PANEL OPERATION

PRELIMINARY PROCEDURES

At power-up, the Calibrator resets to the default settings shown in Table 2-4, in Section 2. The Calibrator also resets to the default power-up settings when the RESET key is pressed.

Warm-Up

3-4.

After the Calibrator is turned on, it must be allowed to warm up for a minimum of 2 hours to ensure that the output meets the specifications listed in Section 1.

If the Calibrator is turned off after it has warmed up, it must be warmed up for a minimum of twice the time it was turned off (up to a maximum of 2 hours of warm up) before the output is stable again. For example, if the calibrator is turned off for 10 minutes, it must be warmed up for a minimum of 20 minutes.

Internal Calibration

3-5.

Internal Calibration is a quick, automatic procedure that enhances the Calibrator's output accuracy. The Calibrator measures its internal voltages and then calculates and stores calibration constants to correct the output for zero and gain shift errors. Once initiated by the operator, the procedure is performed automatically. The procedure takes approximately 5 minutes.

It is recommended that Internal Calibration be performed at the following times:

1. Daily after warm-up, or if the room temperature makes a long-term change larger than $\pm 5^{\circ}\text{C}$.
2. Within 10 minutes prior to performing External Calibration.

Experience has shown that the 5440 Series are extremely stable and that little, if any, correction is made by frequent Internal Calibration. If the Calibrator is operated in a stable environment, it may be found that daily calibration is unnecessary. If the operating environment changes temperature by more than $\pm 5^{\circ}\text{C}$ during the day, more frequent Internal Calibration may be beneficial. The interval may be adjusted to suit your operating environment.

To perform Internal Calibration, proceed as follows:

1. Ensure the Calibrator has warmed up.
2. Disconnect all cables from the front panel terminals and the rear panel ANALOG OUTPUT TERMINALS.
3. In sequence, press the SVCE key, the CAL SVCE soft key, and the INT CAL soft key. The Calibrator will display "REMOVE OUTPUT LEADS & PROCEED WITH INTCAL?"
4. Press the ENTER(YES) key.

The Calibrator then proceeds automatically, indicating each step in the Alphanumeric Display as it is performed. To abort the Internal Calibration procedure, press the RESET key.

While Internal Calibration is being performed, the internal measurements taken during the procedure can be printed via the RS-232-C interface. (See "Printing Data,"

Table 3-2. Soft Key Menus

FRONT PANEL KEY NAME	OPERATING MODE	SOFT KEY NAME	FUNCTION
LIMIT	VOLTAGE MODE	VOLT LIMITS	<p>Press to enter new voltage limits. The following message appears in the Alphanumeric Display:</p> <p>V LIM = +1100.000 V V LIM = -1100.000 V?</p> <p>where the two numbers are the last voltage limits set. The cursor is at the most significant digit of the upper field. Press the center soft key to move the cursor from one field to the other.</p> <p>The m (DATA ENTRY) key toggles the units between V and mV.</p> <p>The +/- (DATA ENTRY) key is ignored.</p> <p>The largest entry allowed is 1100V.</p>
		CURR LIMITS	<p>Press to enter a new current trip point. The following message appears in the Alphanumeric Display:</p> <p>CURR LIM = ±65 mA?</p> <p>where the number is the last current trip point entered.</p> <p>The cursor is at the most significant digit.</p> <p>The m (DATA ENTRY) key toggles the units between A and mA.</p> <p>The +/- (DATA ENTRY) key is ignored because the current trip entry is an absolute value.</p> <p>The largest entry allowed is 65 mA for outputs ≤ 22V and 27.5 mA for outputs > 22V.</p>
	VOLTAGE BOOST	CLEAR LIMITS	<p>Press to set the limits to the default value.</p> <p>Press to enter new voltage limits. The following message appears in the Alphanumeric Display:</p> <p>V LIM = +1500.000 V V LIM = -1500.000 V?</p> <p>where the two numbers are the last voltage limits set. The cursor is at the most significant digit of the upper field. Press the center key to move the cursor from one field to the other.</p>
		VOLT LIMITS	<p>Press to set the limits to the default value.</p> <p>Press to enter new voltage limits. The following message appears in the Alphanumeric Display:</p> <p>V LIM = +1500.000 V V LIM = -1500.000 V?</p> <p>where the two numbers are the last voltage limits set. The cursor is at the most significant digit of the upper field. Press the center key to move the cursor from one field to the other.</p>

FRONT PANEL OPERATION
SOFT KEY MENUS

Table 3-2. Soft Key Menus (cont)

FRONT PANEL KEY NAME	OPERATING MODE	SOFT KEY NAME	FUNCTION
	VOLTAGE BOOST (cont)	VOLT LIMITS (cont)	The m (DATA ENTRY) key toggles the units between V and mV. The +/- (DATA ENTRY) key is ignored. The largest value allowed is 1500V.
		(blank)	No function.
		CLEAR LIMITS	Press to set the limits to the default value.
LIMIT (cont)	CURRENT BOOST	(blank)	No function.
		CURR LIMITS	Press to enter new current limits. The following message appears in the Alphanumeric Display: CURR LIM = +20.000 A CURR LIM = -20.000 A? Where the two numbers are the last voltage limits set. The cursor is at the most significant digit of the upper field. Press the center soft key to move the cursor from one field to the other. The m (DATA ENTRY) key toggles the units between A and mA. The +/- (DATA ENTRY) key is ignored. The largest value allowed is 20A.
		CLEAR LIMITS	Press to set the limits to the default value.
		%ERROR ON	Press to display the deviation of the actual output from the stored error reference value as a percentage. If the deviation is less than 0.1%, the error is displayed in parts per million.
		%ERROR OFF	Press to stop displaying the percentage error.
ERROR MODE	N/A	ENTER TOL	Press to enter the percentage of error and the tolerance floor. One of the following messages appears in the Alphanumeric Display. ENTER TOLERANCE +/- (.00123% +5.00 uV)? ENTER TOLERANCE +/- (.00123% +5.00 uA)?

Table 3-2. Soft Key Menus (cont)

FRONT PANEL KEY NAME	OPERATING MODE	SOFT KEY NAME	FUNCTION	
ERROR MODE (cont)	N/A	ENTER TOL (cont)	where the number expressed in percent is the percentage and the number expressed in volts or amperes is the tolerance floor. Use the center soft key to move the cursor from one data field to the other. Once the data has been entered, the error message is displayed whether the %ERROR ON key has been pressed or not. If the error is less than the tolerance, then a PASS message appears in the lower right corner of the error display. If the error is greater than the tolerance, then a FAIL message appears in the lower right corner of the error display. Tolerance is computed according to the following formula: $T = \pm \{ (\text{percentage} X \text{error reference}) / 100 + \text{tolerance floor} \}$	
BOOST (5-440B Only)	N/A	VOLT BOOST	Press to select Voltage Boost operation.	
		CURR BOOST	Press to select Current Boost operation.	
		BOOST OFF	Press to select Voltage Mode operation.	
SVCE	N/A	SELF TEST	DIGTL TEST	Press to start the Digital Self-test. Press RESET to stop the test.
			ANALOG TEST	Press to start the Analog Self-test. Press RESET to stop the test.
		HIGH V TEST	WARNING	
			TO AVOID SHOCK HAZARD DURING THE HIGH VOLTAGE SELF TEST, NEVER MAKE ELECTRICAL CONTACT WITH THE OUTPUT HI OR SENSE HI TERMINALS OF THE 5440A.	
			Press to start the High Voltage Self-Test. Press RESET to stop the test.	
		CAL SVCE	INT CAL	Press to start the Internal Calibration procedure.
			EXT CAL	Press to start the External Calibration. This is a semi-automatic procedure. The Calibrator prompts the technician.
CAL CONST		Press to display the calibration constants. The calibrator displays calibration constant 00. Repeatedly press the ENTER(YES) key to display the rest of the calibration constants in numerical sequence. Press CLEAR(NO) key to exit this function.		

FRONT PANEL OPERATION
SOFT KEY MENUS

Table 3-2. Soft Key Menus (cont)

FRONT PANEL KEY NAME	OPERATING MODE	SOFT KEY NAME	FUNCTION	
SVCE (cont)	N/A	IEEE ADDR	Press to display or change the IEEE-488 Interface address of the Calibrator. Numbers from 00 through 30 can be entered. The default value is 07. The m,., and +/- DATA ENTRY keys are ignored.	
			SLOWER RS232	Press to select a slower baud rate in the center display.
			RS232 BAUD	Press to select dddd as the baud rate (where dddd is three to four digits of the baud rate).
		PORT SVCE	FASTER BAUD	Press to select a faster baud rate in the center display.
			MONIT ON	Press to print information via the RS-232-C port during Internal Calibration procedures and Analog Self-tests.
			MONIT ON/OFF	No function.
LIST	N/A	MONIT OFF	Press to inhibit printing information during Internal Calibration procedures and Analog Self-tests.	
		LIST HEADER	Press to print the appropriate header via the RS-232-C port. See Section 5 for definitions of the header formats.	
		LIST RESULT	Press to print a summary of a calibration step via the RS-232-C port. See Section 5 for a definition of the results format.	
		MORE LIST	LIST MEMORY (5440B Only)	Press to print a summary of each step stored in sequence memory via the RS-232-C port. The parameters printed for each step are as follows: Output value Limits (voltage and/or current as appropriate) Tolerance specification
			(blank)	No function.
			LIST CAL. K	Press to print the calibration constants via the RS-232-C port.

Table 3-2. Soft Key Menus (cont)

FRONT PANEL KEY NAME	OPERATING MODE	SOFT KEY NAME	FUNCTION
		INSERT STEP	<p>Press to transfer the contents of the Procedure Storage Module to internal memory. The following message appears in the Alphanumeric Display.</p> <p>INSERT PRESENT SETUP BEFORE MEM STEP 0 ? where the number is the sequence step number. Use the (DATA ENTRY) keys to change this step number.</p> <p>The m,., and +/- DATA ENTRY keys are ignored.</p>
EDIT (5440B Only)	N/A	REPLACE STEP	<p>Press to replace the front panel setup stored at the displayed sequence memory step number with the current front panel setup. The following message appears on the Alphanumeric Display.</p> <p>REPLACE MEM STEP 0 WITH PRESENT SETUP? where the number is the sequence step number. Use the DATA ENTRY keys to change this step number.</p> <p>The m,., and +/- DATA ENTRY keys are ignored.</p>
		DELETE STEP	<p>Press to delete the front panel setup stored at the displayed sequence memory step number. The following message appears on the Alphanumeric Display.</p> <p>DELETE STEP 0 FROM SEQUENCE IN MEMORY? where the number is the sequence step number. Use the DATA ENTRY keys to change this step number.</p> <p>The m,., and +/- DATA ENTRY keys are ignored.</p>

FRONT PANEL OPERATION
SOFT KEY MENUS

Table 3-2. Soft Key Menus (cont)

FRONT PANEL KEY NAME	OPERATING MODE	SOFT KEY NAME	FUNCTION
		MODULE TO MEM	<p>Press to transfer the contents of the Procedure Storage Module to the sequence memory. The following message appears in the Alphanumeric Display.</p> <p>PRESS YES FOR MODULE TO OVERWRITE MEMORY?</p> <p>Press the ENTER(YES) (DATA ENTRY) key to transfer the contents of the Procedure Storage Module to internal memory.</p> <p>Press the CLEAR(NO) (DATA ENTRY) key to exit the function without transferring data.</p>
XFER (5440B Only)	N/A	MEM TO MODULE	<p>Press to transfer the contents of internal memory to the Procedure Storage Module. The following message appears in the Alphanumeric Display.</p> <p>DO YOU REALLY WANT COPY MEM TO MODULE?</p> <p>Press the ENTER(YES) (DATA ENTRY) key to transfer the contents of internal memory to the Procedure Storage Module.</p> <p>Press the CLEAR(NO) (DATA ENTRY) key to exit the function without transferring data.</p>
		CLEAR MEMORY	<p>Press to clear internal memory. The following message appears on the Alphanumeric Display.</p> <p>DO YOU REALLY WANT TO CLEAR SEQ IN MEM?</p> <p>Press the ENTER(YES) (DATA ENTRY) key to clear internal memory. Press the CLEAR(NO) (DATA ENTRY) key to exit the function without clearing internal memory.</p>

later in this section.) After Internal Calibration is complete, the Internal Calibration constants can be read from the front panel, printed or displayed via the RS-232-C interface, or sent over the IEEE-488 interface.

External Calibration

3-6.

External Calibration is a semi-automatic procedure which compares the Calibrator's output to traceable voltage standards and corrects the output for long-term drift of the internal voltage reference. External Calibration should be performed at intervals of 30 days to 1 year, depending upon the level of accuracy you wish to maintain.

In the External Calibration procedure, the Calibrator's output is compared to external reference standards in each output voltage range. The Calibrator then calculates and stores calibration constants. These corrections are applied automatically when the Calibrator is used. After External Calibration is complete, the calibration constants can be read from the front panel, printed via the RS-232-C interface, or sent over the IEEE-488 interface.

Instructions for the External Calibration procedure are given at the end of this section. External Calibration is also available at Fluke Technical Service Centers.

SELECTING A VOLTAGE OUTPUT

3-7.

The following paragraphs describe how to set the Calibrator to output a voltage from -1100V to +1100V dc.

Entering a Voltage

3-8.

To select a voltage output, proceed as follows:

1. Ensure the Calibrator is displaying "VOLTAGE MODE" on the Alphanumeric Display. If necessary, press the RESET key to obtain this display.
2. Enter the numerical value of the desired voltage using the numeric DATA ENTRY keys. The value may be any floating point integer of up to eight digits. As you enter the numeric value, the second line of the Alphanumeric Display displays the message "V OUT= xxxxxxxx V ?", where xxxxxxxx is the value you are entering. The \pm key changes the polarity of the output value as it appears in the Alphanumeric Display.
3. Next, press the ENTER(YES) key to cause that value to appear on the Output Display. If you have made an error or want a different voltage, press the CLEAR(NO) key and start over.
4. Set the OPR/STBY (Operate/Standby) key to operate (OPR indicator on). The voltage shown in the Output Display will then appear at the OUTPUT terminals.

In the following example, the Calibrator is set to output 10.000000V dc:

1. With the Alphanumeric Display showing "VOLTAGE MODE", press the 1 and 0 keys. The second line of the Alphanumeric Display will then read:

"V OUT= + 10.000000 V?"

FRONT PANEL OPERATION

SELECTING A DIVIDED VOLTAGE OUTPUT

2. Press the ENTER(YES) key.
3. When you are ready to use the output voltage of the Calibrator, press the OPR/STBY key so that the OPR indicator is on.

NOTE

As a safety feature, the Calibrator trips to standby when you enter a voltage greater than 22V (or less than -22V) from a level below 22V (or above -22V).

When not actually using the voltage output, set the Calibrator to standby. As an added precaution, set the Calibrator's output to zero volts.

Editing a Voltage

3-9.

The EDIT OUTPUT arrow keys allow you to increase or decrease the output voltage of the Calibrator. This feature is normally used to null the reading of a unit under test (UUT) to determine the error of the UUT using the Calibrator's Error Mode feature.

To edit an output voltage, use the right-arrow and left-arrow EDIT OUTPUT keys to position the bright-digit cursor underneath the digit to be changed. Use the up-arrow and down-arrow keys to increase or decrease the value of that digit. Use the CHNG SIGN key to change the polarity of the output voltage.

In the following example, the output voltage is changed (edited) from 10.000000V dc to 10.000004V dc:

1. With the Output Display showing +10.000000V, use the right-arrow EDIT OUTPUT key to position the bright-digit cursor on the right-most digit.
2. Press the up-arrow EDIT OUTPUT key four times. The Output Display will now show +10.000004V.

SELECTING A DIVIDED VOLTAGE OUTPUT

3-10.

The Divider feature provides output voltages from -2.2V to +2.2V dc with improved resolution and noise characteristics. The voltages are obtained using an internal 10:1 and 100:1 voltage divider. The divided output voltage appears at the DIVIDER terminals.

NOTE

The external sense feature (and the EXTERNAL SENSE leads) cannot be used with Divider output voltages. Attempting to do so will degrade the accuracy of the Divider output.

Procedure

3-11.

Divider voltages are selected the same as other output voltages, except that the Divider feature must be enabled:

1. Connect the instrument to be calibrated to the DIVIDER terminals of the Calibrator.

2. Press the DIVIDER key so that the corresponding "ON" indicator is on.
3. Enter a voltage from -2.2V to +2.2V dc using the DATA ENTRY keys. As you enter the numeric value, the second line of the Alphanumeric Display displays the message "V OUT= xxxxxxxx V ?", where xxxxxxxx is the value you are entering. Then press the ENTER(YES) key.
4. Set the OPR/STBY key to Operate (OPR indicator on). The voltage shown in the Output Display will appear at the DIVIDER terminals.

Considerations

3-12.

The DIVIDER terminals have an output impedance of 450 Ω for the 2V range and 495 Ω for the 0.2V range. Any current drawn will degrade the accuracy of the divided output voltage. Therefore, divided output voltages are suitable only for calibrating high-impedance voltmeters.

The possible degradation of the accuracy of the output voltage can be easily calculated. The loading error is equal to the output impedance of the Calibrator, divided by the input (shunting) impedance of the meter. For example, if you are calibrating a meter with a 10 M Ω input impedance on the 2V range, then the error would be $450\Omega / 10M\Omega = -45$ ppm. On the 0.2V range the error would be $459\Omega / 10M\Omega = -49.5$ ppm.

The previous example shows a typical worst-case situation. Most voltmeters that require the accuracy provided by the Calibrator's divided output voltages have impedances in the 1000 M Ω range. This reduces the typical loading error to 0.45 ppm.

DISPLAYING UUT ERROR

3-13.

The Calibrator can calculate and display the deviation of the unit under test (UUT) relative to a stored reference. Errors below 1000 ppm (parts per million) are displayed in ppm; errors of 0.1% or more are displayed in percent.

The Calibrator can also display the error of the UUT as a pass or fail result, comparing the error to a user-specified tolerance. The tolerance is entered as the allowable deviation (in percent of output) plus the tolerance floor (in microvolts). Once a tolerance has been entered, the Calibrator automatically displays the deviation in ppm or percent and displays a PASS or FAIL message.

The Calibrator's output is automatically stored as the reference when the ENTER(YES) key is pressed to enter an output. At any time, the present output of the Calibrator can also be stored as a new reference by pressing NEW REF key. The stored reference can be recalled by pressing the RCALL REF key.

Typically, the Calibrator is set to a nominal voltage (e.g., 1.0000000V) with the DATA ENTRY keys. In this case, the UUT might give a reading of 1.0000055V. The EDIT OUTPUT keys are then used to adjust the Calibrator's output until the UUT reads the nominal voltage (1.0000000V). The Calibrator then displays the UUT's error in percent or ppm (and as PASS or FAIL, if tolerances have been specified).

Basic Error Display

3-14.

To obtain a display of the UUT's error, press the ERROR MODE key and then press the %ERROR ON soft key. The deviation error is displayed following the message "VOLTAGE MODE ERR =" on the Alphanumeric Display.

FRONT PANEL OPERATION

DISPLAYING UUT ERROR

To disable the error display, press the ERROR MODE key, then press the %ERROR OFF soft key.

The following example shows how to display the error in percent or ppm:

1. Using the DATA ENTRY keys, enter 10.000000V, press ENTER(YES), and set the Calibrator to OPR.
2. Use the EDIT OUTPUT keys to obtain a reading on the UUT of 10.000000V (the nominal value). If the UUT displayed 9.942V, the Calibrator output required to obtain a UUT reading of 10.000V would be approximately 10.058600V.
3. Press the ERROR MODE key, then press the %ERROR ON soft key. The Alphanumeric Display then reads:

VOLTAGE MODE

ERR = xxxxx

where xxxxx is the deviation in percent or ppm. (If the UUT originally read 9.942V, the error would be approximately -.58600%.)

Entering Tolerances

3-15.

To enter a tolerance, proceed as follows:

1. Press the ERROR MODE key, then press the ENTER TOL soft key. The message "ENTER TOLERANCE \pm (.)0000% +00.0 μ V?" appears on the Alphanumeric Display.
2. Use the DATA ENTRY keys to enter the percent of output and tolerance floor. The center soft key moves the cursor between the percent of output and the floor specification.

After the tolerance has been entered, proceed to null the UUT reading as usual.

Converting UUT Specifications

3-16.

When entering tolerances, you may need to convert the UUT's published specifications into the units used by the Calibrator. For example, consider a UUT whose accuracy on the 10V range is specified as \pm (0.001% of input plus 0.002% of range). The percent of input (0.001%) can be entered directly as the percent of output. However, the range value (0.002%) must be converted into microvolts for the floor value. In this case, 0.002% converts to 200 μ V (0.002% of 10V is 200 μ V). The tolerance can then be entered as follows:

1. Press the ERROR MODE key, then press the ENTER TOL soft key.
2. Using the numeric DATA ENTRY keys, enter ".001" (the percent of output).
3. Press the center soft key.
4. Using the numeric DATA ENTRY keys, enter "200" (the floor in μ V).
5. Press the ENTER(YES) key.

SETTING OUTPUT LIMITS

3-17.

The Calibrator has an output limit feature to help prevent accidental damage to UUTs from overcurrent and overvoltage conditions. This feature allows you to preset the maximum allowable output voltage (both positive and negative) and current. The power-up default limits are $\pm 1100\text{V}$ and $\pm 65\text{ mA}$ for normal Voltage Mode operation. In Voltage Boost and Current Boost operation (5440B only), the default limits are $\pm 1500\text{V}$ and $\pm 20\text{A}$, respectively.

Setting Current Limits

3-18.

The current limit setting is applied to both positive and negative voltages. If an output exceeds the current limit, the Calibrator trips to standby after a programmed delay of 4 seconds. The delay allows time for the output to settle and internal capacitors to charge. After the 4-second delay, the Calibrator begins again to sample the output current at 1-second intervals.

CAUTION

Because of the programmed delay, some instruments may not be adequately protected from overcurrent conditions.

The maximum transient output current is about 80 mA. (The actual current value depends on the load impedance and output voltage.) This value is fixed by current limiting circuitry in the Calibrator.

To set the output current limit, press the LIMIT key, then press the CURR LIMIT soft key. The message "VOLTAGE MODE CURR LIM = $\pm 65.0\text{mA}$?" appears on the Alphanumeric Display, with the cursor on the "6" digit. Use the DATA ENTRY keys to change the displayed value. The m key changes the units of the displayed value between milliamperes and amperes. Alternatively, use the two outer soft keys to position the cursor on the digit to be changed, then enter the new digit using the DATA ENTRY keys. After changing the current limit value, press the ENTER(YES) key to enter that value as the new current limit.

In the following example, the current limit is set to 10.5 mA:

1. Press the LIMIT key, then press the CURR LIMITS soft key.
2. Using the numeric DATA ENTRY keys, enter "10.5".
3. Press the ENTER(YES) key.

Setting Voltage Limits

3-19.

The voltage limits can be set individually for positive and negative output voltages. Once voltage limits have been set, the Calibrator does not allow you to enter a voltage that would exceed those limits. If you attempt to enter a voltage that is beyond those limits, the message "USER ENTRY ERROR OUTPUT OUT OF RANGE" appears on the Alphanumeric Display.

NOTE

Voltage limits and output voltage monitoring are separate functions.

Voltage Monitoring

3-20.

In addition to the limits feature, the Calibrator has an internal analog-to-digital converter which periodically monitors the output voltage. If the measured voltage differs more than 5% from the selected voltage, the Calibrator returns to standby and the Alphanumeric Display shows an error message ("UNDERVOLTAGE" or "OVERVOLTAGE"). This monitor does not test for accuracy; it checks that the Calibrator is functioning and serves as a safety monitor. The monitor delays 4 seconds following any programmed change in the output voltage or following a change from standby to operate.

The monitor alternately checks the output current and output voltage. Therefore, shorting the Calibrator's output may result in either a UNDERVOLTAGE or OVERCURRENT error message, depending when the short occurs. (A short results in undervoltage due to the Calibrator's current limiting circuitry.)

SELECTING A BOOST OUTPUT (5440B ONLY)

3-21.

WARNING

BOOST OPERATION PRODUCES VOLTAGES AND CURRENTS ABOVE THOSE NORMALLY AVAILABLE. THE POTENTIAL RISK OF INJURY OR FATAL ACCIDENT IS GREATER THAN THAT OF NORMAL OPERATION.

Boost operation provides output voltages up to $\pm 1500\text{V}$, or current outputs up to 20A, using the Calibrator to drive a Fluke 5205A Precision Power Amplifier or Fluke 5220A Transconductance Amplifier. The Calibrator's Output Display shows the voltage or current output of the amplifier, not the output of the Calibrator itself.

Voltage Boost Output

3-22.

For Voltage Boost operation, the Calibrator is connected to the Fluke 5205A Precision Power Amplifier. The Calibrator/Power Amplifier combination has an output voltage range of -1500V to -100V and $+100\text{V}$ to $+1500\text{V}$. The maximum load current is 100 mA. The default parameters for Voltage Boost operation are given in Table 3-3.

To use the Voltage Boost feature, proceed as follows:

1. Connect the 5205A to the two rear panel Calibrator connectors labeled 5205A using the Fluke Y5001 Interface Cable.
2. Connect the UUT to the output of the 5205A.
3. Press the BOOST key, then press the VOLT BOOST soft key. If the amplifier is not correctly connected to the Calibrator, the message "BOOST INTERF ERROR CHECK REAR CONNECTOR" appears on the Alphanumeric Display.
4. Use the DATA ENTRY keys to select the desired voltage output from the 5205A. When the Output Display shows the desired output, press the ENTER(YES) key.
5. Set the OPR/STBY key to operate (OPR indicator on). The reference voltage is now applied to the inputs of the 5205A and the resulting high voltage is available at its output.

Table 3-3. Voltage Boost Default Settings

PARAMETER	VALUE/STATUS
Output Voltage	100V dc
Error Mode Reference	0 mV dc
Voltage Limits	+1500V dc, -1500V dc
Tolerance	0% of Reading
	0 μ V Floor
Instrument Status	Standby

All other Calibrator operations are the same for Voltage Boost operation as for Voltage Mode operation, except that the maximum allowable output voltage limits are increased to $\pm 1500V$ dc (at the Amplifier's output) and the current limit feature is disabled.

In the following example, in which the Calibrator is connected to a 5205A, an output of $\pm 1500V$ dc is selected:

1. Press the BOOST key, then press the VOLT BOOST soft key.
2. Using the DATA ENTRY keys, enter "1500".
3. Press the ENTER(YES) key.

Current Boost Output

3-23.

In Current Boost operation, the Calibrator is connected to the Fluke 5220A Transconductance Amplifier. The Calibrator-Transconductance Amplifier combination can produce currents up to 20A with a compliance voltage of 4V. The default parameters for Current Boost operation are given in Table 3-4.

To use the Current Boost feature, proceed as follows:

1. Connect the 5205A to the two rear panel Calibrator connectors labeled 5220A using the Fluke Y5002 Interface Cable.
2. Connect the UUT to the output of the 5220A.
3. Press the BOOST key, then press the CURR BOOST soft key. If the amplifier is not correctly connected to the calibrator, the message "BOOST INTERF ERROR CHECK REAR CONNECTOR" appears on the Alphanumeric Display.

Table 3-4. Current Boost Default Settings

PARAMETER	VALUE/STATUS
Output Current	0A dc
Error Mode Reference	0A dc
Current Limits	$\pm 20A$ dc
Tolerance	0% of Reading
	0 μ V Floor
Instrument Status	Standby

FRONT PANEL OPERATION

PRINTING DATA

4. Use the DATA ENTRY keys to select the current output desired from the 5220A. When the Output Display shows the desired current output from the 5220A, press the ENTER(YES) key.
5. Set the OPR/STBY key to operate (OPR indicator on). The reference voltage is now applied to the inputs of the 5220A and the resulting current is available at its output.

All other Calibrator operations are the same for Current Boost operation as for Voltage Mode operation, except that the maximum allowable current limit is increased to $\pm 20A$ (at the Amplifier's output) and the voltage limit feature is disabled.

In the following example, in which the Calibrator is connected to a 5220A, an output of 10A is selected:

1. Press the BOOST key, then press the CURR BOOST soft key.
2. Using the numeric DATA ENTRY keys, enter "10".
3. Press the ENTER(YES) key.

SETTING COMMUNICATION PARAMETERS

3-24.

The calibrator has two interfaces, the IEEE-488 interface and the RS-232-C interface. The IEEE-488 interface is used to operate the Calibrator from a remote instrument controller. Complete instructions for IEEE-488 operation are given in Section 4, including instructions for setting the Calibrator's bus address.

The RS-232-C interface is used to print out or display calibration and self-test results on a serial printer or video monitor. Instructions for connecting a printer or monitor to the its RS-232-C interface are given in Section 5, including setting the Calibrator's baud rate and configuring the Calibrator's RS-232-C connector wiring. Instructions for printing and displaying data are given in the previous paragraphs on Printing Data. (Instructions for printing self-test results are given in the 5440 Series Service Manual.)

PRINTING DATA

3-25.

The Calibrator allows you to print the calibration results of your UUT (with a preformatted header), listings of stored procedures (5440B only), the Calibrator's internal calibration constants, and the results of the analog and high voltage self-tests. (Refer to the 5440 Series Service Manual for information on printing self-test results.)

Before any printing can take place, a printer with a serial interface must be connected to the RS-232-C port, and the Calibrator's baud rate must be set. Procedures for connecting a printer and setting the baud rate are contained in Section 5.

Printing a Header

3-26.

The header is normally printed before printing the UUT's calibration results. The header provides space to write in the date, the type of equipment tested, operator ID, and other information. Figure 3-1 shows what the header looks like.

To print the header, press the LIST key, then press the LIST HEADER soft key. The message "VOLTAGE MODE" will appear briefly on the Alphanumeric Display,

```

JOHN FLUKE MFG. CO., INC.                               5440 UUT RESULTS
-----
DATE..... OPERATOR.....
INSTRUMENT..... SERIAL NO.....
  
```

Figure 3-1. Example Header Listing

```

JOHN FLUKE MFG. CO., INC.                               5440 UUT RESULTS
-----
DATE..... OPERATOR.....
INSTRUMENT..... SERIAL NO.....
-----
STEP   OUTPUT   REFERENCE   TOLERANCE SPEC   % ERROR
-----
01    +1.0000012 V  +1.0000000 V  +.00100%+2.000uV  -1.2000PPM
02    +12.000200 V  +12.000000 V
03    +13.000030 V  +13.000000 V                                -2.3000PPM
04    +14.022340 V  +14.000000 V  +.00100%+2.000uV  -.1595%   FAIL
05    +15.005000 V  +15.000000 V  +.00100%+2.000uV  -333.30PPM FAIL
  
```

Figure 3-2. Example Results Listing

followed by the message "...PRINTING...". The Calibrator then returns to its previous operating mode.

Printing UUT Calibration Results

3-27.

The Calibrator can print the results of a calibration step when calibrating a UUT. The printed data includes the reference voltage of the Calibrator (the intended UUT nominal), the output needed to achieve a nominal reading on the UUT, the tolerance specification, and the UUT error. (If tolerance limits have been set, a PASS/FAIL indication is also listed.) Each step must be printed individually as it is completed.

Figure 3-2 shows an example of what the calibration results would look like after performing and printing the results of several calibration steps. The header is printed first, in a separate step.

To print a calibration step, press the LIST key, then press the LIST RESULT soft key. The message "VOLTAGE MODE" will appear briefly on the Alphanumeric Display, followed by the message "...PRINTING...". The Calibrator then returns to its previous operating mode.

Printing Internal Calibration Constants

3-28.

The Calibrator can print the calibration constants obtained during the Internal Calibration procedure. Figure 3-3 shows an example listing of the calibration constants.

To print the calibration constants, press the LIST key, then press the MORE LIST soft key. After the second menu appears, press the "LIST CAL. K" soft key. The message "VOLTAGE MODE" will appear briefly on the Alphanumeric Display, followed by the message "...PRINTING...". The Calibrator then returns to its previous operating mode.

Printing Stored Procedures (5440B Only)

3-29.

The 5440B can print a listing of the procedure stored in its internal memory. The listing contains the step number, output limits, and Calibrator state. An example listing is shown in Figure 3-4.

To print a stored procedure, press the LIST key, then the MORE LIST soft key, then the LIST MEMORY soft key. The message "VOLTAGE MODE" will appear briefly on the Alphanumeric Display, followed by the message "...PRINTING...". The Calibrator returns to the previous operating mode after the procedure has been printed.

PERFORMING SELF-TESTS

3-30.

The Calibrator's self-tests functionally test the three types of circuits within the instrument (digital, analog, and high voltage). The self-tests provide a measure of confidence in the operation of the Calibrator. Self-tests are also useful for troubleshooting the Calibrator. (Refer to the 5440 Series Service Manual for information on troubleshooting with the self-test features.)

Self-tests should be performed on a routine basis or when the operation of the Calibrator is in question. The following paragraphs describe how to initiate the self-tests.

JOHN FLUKE MFG. CO., INC.		5440 CALIBRATION DATA		
CONSTANT	10V RANGE	20V RANGE	250V RANGE	1000V RANGE
Gain	+5.54313609 mV	+1.0862640 mV	+13.577998 mV	+54.311978 mV
2V Gain		+1.0862762 mV		
.2V Gain		+1.0862863 mV		
+Offset	+4.8645389 mV	+9.7681830 mV	+122.47198 mV	+490.39426 mV
-Offset	+5.5948529 mV	+11.149847 mV	+139.00318 mV	+555.53586 mV
Gain Shift	-.0 PPM	-.0 PPM	-.0 PPM	-.0 PPM
Resolution ratio: 7292		A/D gain: +.2813 mV		

Figure 3-3. Example Calibration Constants Listing

JOHN FLUKE MFG. CO., INC.		5440 SEQUENCE LISTING	
DATE _____		OPERATOR _____	
STEP	OUTPUT	LIMITS	STATE
01	+1.000000 V	+2.000000 V -2.000000 V +5.00mA	STBY DIV TOL SPEC:+.00100%+2.000uV
02	+12.000000 V	+100.00000 V -100.00000 V +20.0mA	STBY
03	+13.000000 V	+100.00000 V -100.00000 V +20.0mA	STBY EXTGRD Z ERROR ON
04	+14.000000 V	+1100.0000 V -1100.0000 V +25.0mA	STBY TOL SPEC:+.00100%+2.000uV
05	+15.000000 V	+1100.0000 V -1100.0000 V +25.0mA	STBY EXTSENS TOL SPEC:+.00100%+2.000uV

Figure 3-4. Example Stored Procedure Listing

Digital Self-Test

3-31.

To initiate the Digital Self-Test, press the SVCE key, then the SELF TEST soft key, then the DIGITL TEST soft key. The message "PERFORMING DIGITAL SELF-TEST. WAIT" will appear on the Alphanumeric Display.

If a fault is found in the digital circuits, the self-test stops and an error message appears on the Alphanumeric Display. Record the error message and contact a qualified service technician or the nearest Fluke Service Center for repairs.

Analog Self-Test

3-32.

Use the following procedure to initiate the Analog Self-Test:

1. Press the SVCE key, then the SELF TEST soft key.
2. Press the ANALOG TEST soft key. The following message will appear on the Alphanumeric Display:

REMOVE OUTPUT LEADS

& DO ANALOG TEST ?

3. Remove all output connections (front and rear panel) from the output terminals of the Calibrator.
4. After removing the output leads, press the ENTER(YES) key to start the Analog Self-Test. The following messages appear sequentially on the Alphanumeric Display.

INTERNAL CALIBRATION

**FRONT PANEL OPERATION
CREATING AND EDITING PROCEDURES**

A TO D. WAIT.

PERFORMING ANALOG

SELF-TEST. WAIT.

If a fault in the analog circuitry is found, the self-test stops and an error message appears on the Alphanumeric Display. Record the error message and contact a qualified service technician or the nearest Fluke Service Center for repairs.

High Voltage Self-test

3-33.

WARNING

LETHAL VOLTAGES ARE PRESENT ON THE OUTPUT OR SENSE TERMINALS DURING THE HIGH VOLTAGE SELF-TEST. TO AVOID SHOCK HAZARD, DO NOT MAKE CONTACT WITH THESE TERMINALS DURING THE HIGH VOLTAGE SELF-TEST.

Use the following procedure to initiate the High Voltage Self-Test:

1. Press the SVCE key, then the SELF TEST soft key.
2. Press the HIGH V TEST soft key. The following message will appear on the Alphanumeric Display:

REMOVE OUTPUT LEADS&

DO HIGH VOLT TEST ?

3. Remove all output connections (front and rear panel) from the output terminals of the Calibrator.
4. After removing the output leads, press the ENTER(YES) key to start the High Voltage Self-Test. The following messages appear sequentially on the Alphanumeric Display.

INTERNAL CALIBRATION

A TO D. WAIT.

DOING HIGH VOLTAGE

OUTPUT TEST. WAIT.

If a fault is found in the high voltage circuits, the self-test stops and an error message appears on the Alphanumeric Display. Record the error message and contact a qualified service technician or the nearest Fluke Service Center for repairs.

CREATING AND EDITING PROCEDURES (5440B ONLY)

3-34.

The 5440B lets you store and edit a sequence of up to 60 Calibrator settings for quick recall at a later time. The sequences (referred to as procedures) can shorten redundant calibration procedures to a few key strokes. This feature is especially useful in production environments.

A procedure is created, edited, and executed in internal, volatile memory. It can then be transferred to non-volatile memory in the removable Procedure Storage Module. A procedure can also be transferred back to internal memory, from the Procedure Storage Module, for execution or editing.

Each step in a procedure contains the selected output value, the mode (Voltage Mode, Current Boost, or Voltage Boost), the output state (OPR or STBY), voltage/current/tolerance limits, and Error Mode information (Error Mode on or off).

Creating a Procedure

3-35.

A calibration procedure is created by adding one step at a time. Each step is added by configuring the Calibrator as desired using the front panel controls, and then pressing the ADD STEP key. The first step is stored in internal memory as step 1 (S01), the second as 2 (S02), the third as step 3 (S03), and so on. The step number is displayed in the Alphanumeric Display.

For example, to create a sequence of steps to output 1V, 2V, 3V, and 4V, proceed as follows:

1. In sequence, press the 1, ENTER, OPR, and ADD STEP keys.
2. In sequence, press the 2, ENTER, and ADD STEP keys.
3. In sequence, press the 3, ENTER, and ADD STEP keys.
4. In sequence, press the 4, ENTER, and ADD STEP keys.

The complete state of the Calibrator is stored at each step. Before pressing the ADD STEP key, you can set current and voltage limits, the allowed tolerance, or any other parameter for that particular step, including the Error Mode or Boost operation.

Executing a Procedure

3-36.

Once a procedure is stored in internal memory, it is recalled using the NEXT STEP, PREV STEP, or SEL STEP keys. When a step is recalled, the Calibrator assumes the settings stored with that step.

To start a procedure at step 1, press the NEXT STEP key. To proceed to subsequent steps, press the NEXT STEP again. To recall previous steps, press the PREV STEP key.

To jump to another step in the procedure, press the SEL STEP key. The message "SETUP CALIBRATOR WITH STEP 0 OF SEQ MEM?" will appear on the Alphanumeric Display. Then, enter the desired step number using the DATA ENTRY key, and press the ENTER(YES) key.

Editing a Procedure

3-37.

Procedures stored in internal memory can be altered using the MEMORY CONTROL keys. These keys allow you to insert additional steps in the procedure, to change the instrument settings for any step, and to delete any step from the procedure.

Inserting a Step

3-38.

To insert a new step in the procedure, proceed as follows:

1. Set the Calibrator to the configuration desired for the new step.

FRONT PANEL OPERATION
CREATING AND EDITING PROCEDURES

2. Press the EDIT key, then the INSERT STEP soft key. The message "INSERT PRESENT SETUP AT SEQ MEM STEP 0 ?" will appear on the Alphanumeric Display.
3. Enter the step number for the new step. (For example, to insert a step between steps 3 and 4, enter the number 4.) The present configuration is then stored at the step number you just entered, and all subsequent step numbers are automatically increased by 1. (For example, what was step 4 becomes step 5, what was step 5 becomes step 6, and so on.)

Changing a Step

3-39.

To change the Calibrator settings for a particular step in a procedure, proceed as follows:

1. Press the SEL STEP key.
2. Using the DATA ENTRY keys, enter the number of the step to be changed, and press the ENTER(YES) key. The Calibrator will assume the settings of the selected step.
3. Change the Calibrator settings as desired.
4. Press the EDIT key, then the REPLAC STEP soft key. To guard against accidental changes, the message "REPLACE MEM STEP 0 WITH PRESENT SETUP ?" appears on the Alphanumeric Display.
5. Using the DATA ENTRY keys, reenter the number of the step and press the ENTER(YES) key.

Deleting a Step

3-40.

To delete a step from a procedure, proceed as follows:

1. Press the EDIT key, then press the DELETE STEP soft key. The message "DELETE STEP 0 FROM SEQUENCE IN MEMORY?" will appear on the Alphanumeric Display.
2. Enter the number of the step you want to delete and press the ENTER(YES) key.

Exiting a Procedure

3-41.

To exit a procedure, press the RESET key. This causes the Calibrator to return to the power-up default settings.

During a procedure, you can reconfigure the Calibrator using the front panel keys. When the Calibrator is reconfigured in this way, the step number appears in the Alphanumeric Display without the leading "S". The stored procedure is not altered unless the EDIT memory features are used.

Clearing Internal Memory

3-42.

The procedure stored in internal memory can be cleared (deleted) from memory as follows:

1. Press the XFR key, then the CLEAR MEMORY soft key. The message "DO YOU REALLY WANT TO CLEAR SEQ IN MEM?" will appear on the Alphanumeric Display.

2. Press the ENTER(YES) key.

STORING PROCEDURES (5440B ONLY)

3-43.

For long-term storage, a procedure created in internal memory can be transferred to the non-volatile memory of the Procedure Storage Module.

NOTE

5440B instruments with serial numbers equal to or greater than 4105000 have the 60 mA output capability. Below that number, the output capability is 25 mA. Another way to determine the output capability is to select a current limit greater than 25 mA and less than or equal to 65 mA. If the 5440B accepts the current limit, it has the 60 mA capability. If a program is written into the memory module from a 5440B with the 60 mA capability and that memory module is later used to program a 5440B with only 25 mA capability, the program will be rejected. To avoid this situation, program a current limit of 25 mA or less into the memory module.

Transferring from Internal Memory to Module

3-44.

To transfer a procedure from internal memory to the Procedure Storage Module, proceed as follows:

1. Press the XFR key, then press the MEM TO MODULE soft key. The message "DO YOU REALLY WANT TO COPY MEM TO MODULE?" will appear on the Alphanumeric Display.
2. Press the ENTER(YES) key.

NOTE

The memory module is equipped with a write protect switch. If the switch is placed in the ON (Write protect) position, and an attempt is made to transfer memory to module, the following error message will appear:

**STORAGE MODULE ERROR
CANNOT WRITE MODULE**

Transfer may be accomplished by removing the module from the socket, switching the WRITE PROTECT switch off, replacing the module and repeating the transfer sequence.

Transferring from Module to Internal Memory

3-45.

To transfer a procedure from the Procedure Storage Module back to internal memory, proceed as follows:

1. Press the XFR key, then press the MODULE TO MEM soft key. The message "DO YOU REALLY WANT TO COPY MODULE TO MEM?" will appear on the Alphanumeric Display.
2. Press the ENTER(YES) key.

FRONT PANEL OPERATION
EXTERNAL CALIBRATION PROCEDURE

NOTE

If the Calibrator has been powered-up with the Memory Module WRITE PROTECT switch in the OFF position, and the switch is then changed to the ON position, an attempt to transfer data from Module to Memory will result in the following error message:

*STORAGE MODULE ERROR
BAD STEP IN SEQ MEM*

To complete the transfer from Module to Memory it will be necessary to return the WRITE PROTECT switch to the OFF position or to momentarily switch off the line power and power-up the Calibrator with the WRITE PROTECT switch in the On position if WRITE PROTECT is required.

EXTERNAL CALIBRATION PROCEDURE

3-46.

External Calibration is a semi-automatic procedure which compares the Calibrator's output to traceable voltage standards and corrects the Calibrator's output for long-term drift of the internal voltage reference. The recommended procedure uses the Fluke 732A Direct Voltage Reference Standard and the Fluke 752A Reference Divider to establish the necessary voltage standards which are then compared to the Calibrator with the Fluke 845A Null Detector.

External Calibration should be performed at an interval from 30 days to 1 year, depending upon the level of accuracy you wish to maintain.

The principal function of External Calibration is to correct for any shift in the Calibrator's internal voltage reference. A second function is to correct for long-term drift in the internal voltage divider resistors used for the 2.0V and 0.2V divided output ranges. All other time and temperature dependent changes in the Calibrator are corrected by the Internal Calibration procedure.

An abbreviated External Calibration procedure ("10V Cal") may be used following Internal Calibration to complete the calibration of all ranges except the 0.2V and 2.0V ranges. The abbreviated procedure is performed by comparing the Calibrator's output at 10V to the 732A Reference Standard, generating a calibration factor, and then applying the same correction factor to all ranges to correct for reference voltage shift.

The External Calibration procedure is arranged so that the 10V range is calibrated first, followed by the 20V, 0.2V, 2.0V, 250V, and 1100V ranges. If the full calibration procedure is used, each range is compared against the calibration standards and a correction factor is determined for that range. If the abbreviated procedure is to be used, calibration of all ranges except 10V is skipped in the procedure, and the 10V range correction factor is applied.

To perform External Calibration, proceed as follows:

1. Perform the Internal Calibration procedure described earlier in this section, under the heading "Preliminary Procedures."

NOTE

Ensure the Calibrator has warmed up before performing Internal Calibration.

FRONT PANEL OPERATION
EXTERNAL CALIBRATION PROCEDURE

2. Connect the test equipment as shown in Figure 3-5.
3. Turn on the Calibrator and all test equipment and ensure that the 2 hour warm-up period has been satisfied before performing the calibration procedure.
4. Adjust the zero setting on the 845A Null Detector. Calibrate the 752A Reference Divider. Set the 752A for the 10V range.
5. Remove the decal covering the CAL/NORMAL switch, and set the CAL/NORMAL switch on the rear panel of the Calibrator to the CAL position.
6. Initiate External Calibration by pressing the following sequence of keys and soft keys: SVCE, CAL SVCE, EXT CAL. The following message will appear on the Alphanumeric Display:

PERFORM EXTERNAL
CALIBRATION?

7. Press the ENTER(YES) key. The following message will appear on the Alphanumeric Display:

CONNECT OUTPUT
FOR 10 VOLT EXT CAL?

8. Press the ENTER(YES) key. The following message will appear on the Alphanumeric Display:

EXT CAL OF 10V RANGE
STD V=10.00000V?

9. If the voltage reference standard is not exactly 10V, the exact value may be entered at this time with the numeric DATA ENTRY keys. When the Alphanumeric Display indicates the correct voltage, press the ENTER(YES) key. The following message will appear on the Alphanumeric Display:

EDIT OUTPUT VOLTAGE,
PUSH ENTER WHEN NULL

10. Set the OPR/STBY key to Operate (OPR indicator on). Switch the 845A Null Detector to OPR and adjust the output voltage of the Calibrator using the EDIT OUTPUT keys to obtain a null indication on the Null Detector.

11. Switch the null detector to ZERO and press the ENTER(YES) key. The following message will appear on the Alphanumeric Display:

EXT CAL OF 20V RANGE
STD V =10.00000V?

12. At this point the decision may be made whether to perform the complete calibration procedure or the abbreviated procedure. To perform the complete calibration procedure, follow the prompting of the Alphanumeric Display to calibrate each range as follows:
 - a. Set the 752A range for the STD V indicated and press the ENTER(YES) key.
 - b. Set the Calibrator to OPR and edit for null.
 - c. Press the ENTER(YES) key and go to the next range.
13. To perform the abbreviated procedure, when the display prompts for the 20V range as above, press the CLEAR(NO) key. The Calibrator will then prompt:

CONNECT DIVIDER OUT

FOR 2V & .2V EXTCAL?

14. Again press the CLEAR(NO) key. The Calibrator will then prompt:

CONNECT OUTPUT FOR

HI VOLT EXT. CAL?

15. Again press the CLEAR(NO) key. The Calibrator will then prompt:

WRITING TO NV MEMORY

WAIT

NOTE

Writing the calibration constants into memory takes about 35 to 40 seconds, after which the Calibrator returns to 0.0V output, standby, and Voltage Mode. If the complete calibration procedure is run, it concludes in the same way: The Calibrator writes the calibration constants into memory and returns to Standby as soon as the calibration of the 1100V range is completed.

16. Set the CAL/NORMAL switch to the NORMAL position and cover the switch with a certification decal.

Section 4

Remote Operation

INTRODUCTION

4-1.

This section describes how to operate the Calibrator using the IEEE-488 Interface. The programmer should read and thoroughly understand the information in Section 3 (local operation) as well as the information in this section before attempting to program the Calibrator.

The Calibrator is completely programmable using the IEEE-488 interface. IEEE-488 messages duplicate the function of all front panel controls except the 5440B memory features. (Memory features are not available for the 5442A.) The Calibrator is designed in accordance with the IEEE Standard 488-1978 and 1980 supplement, for use with any IEEE-488 controller.

IEEE-488 INTERFACE FUNCTIONS

4-2.

The IEEE-488 interface functions supported by the Calibrator are listed in Table 4-1.

CONNECTING THE CALIBRATOR TO THE BUS

4-3.

The following steps must be taken to connect the Calibrator to the IEEE-488 interface bus:

1. Set the IEEE-488 bus address of the Calibrator. (Instructions are given below.)
2. Connect the proper cables between the instruments on the bus.
3. Comply with the IEEE-488 bus restrictions.

The following paragraphs describe the procedures you will use to complete the above steps.

Setting the IEEE-488 Address

4-4.

The IEEE-488 bus address is entered from the front panel as a value between 0 and 30. The address is stored in nonvolatile memory. The default bus address is 7.

To set the IEEE-488 bus address of the Calibrator, use the following procedure:

1. Press the SVCE (DATA ENTRY) key, then the PORT SERV soft key, then the IEEE ADDR soft key.
2. The following message appears on the Alphanumeric Display:

REMOTE OPERATION
REMOTE AND LOCAL STATES

Table 4-1. Interface Functions

INTERFACE FUNCTION	COMMENTS
SH1	Complete source handshake capabilities
AH1	Complete acceptor handshake capabilities
RL1	Complete remote local capabilities
T6	Basic talker, Serial poll. Unaddressed if MLA.
TE0	No extended talker capabilities
L4	Basic listener, unaddressed if MLA
LE0	No extended listener capabilities
SR1	Complete service request capabilities
PP0	No parallel poll capabilities
DC1	Complete device clear capabilities
DT0	No device trigger capabilities
C0	No controller capabilities
E1	Open collector output

SELECT IEEE-488 BUS ADDRESS = 07 ?

Address 07 is the default setting. If a different address is stored in nonvolatile memory, that address will be displayed.

3. Enter the new IEEE-488 address using the numerical (DATA ENTRY) keys. The new address will appear on the Alphanumeric Display. The address can be any decimal value from 00 through 30.
4. Press ENTER(YES). The new IEEE-488 address is set, and stored in nonvolatile memory.

Connecting IEEE-488 Cables 4-5.

The IEEE-488 connector on the rear panel mates with any IEEE Standard 488-1978 cable. The pin-outs of the rear panel IEEE-488 connector are shown in Figure 4-1.

The IEEE-488 interface cable accessories are listed in the Section 7. Combinations of these cables can be used if their configuration meets the IEEE-488 cable restrictions.

IEEE-488 Bus Restrictions 4-6.

The following restrictions apply to all IEEE-488 systems:

1. A maximum of 15 devices can be connected in a single IEEE-488 Bus system.
2. The total length of cable used in one IEEE-488 Bus system must not exceed 20 meters or 2 meters times the number of devices in the system, whichever is less.

REMOTE AND LOCAL STATES 4-7.

The Calibrator operates in four different states: Local, Local With Lockout, Remote, and Remote With Lockout. The state in which the Calibrator operates is determined by the Calibrator front panel controls and the IEEE-488 interface controller.

Local States 4-8.

In both of the local states, the Calibrator is controlled by front panel operation. While in the local states, the Calibrator has the following characteristics:

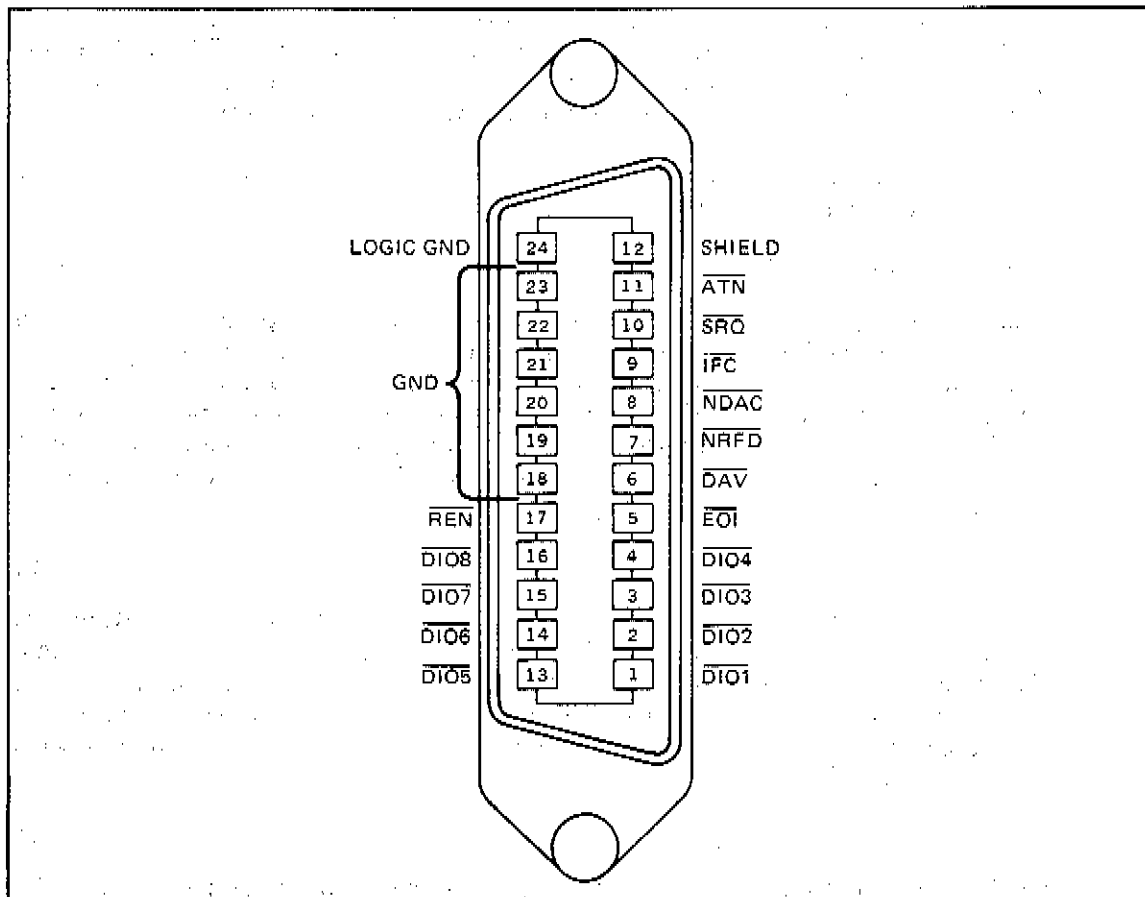

Figure 4-1. IEEE-488 Connector

1. The only difference between operation in the two local states is the remote state to which control is transferred when the correct My Listen Address (MLA) is sent while the REN command line is true.
 - a. If the Calibrator is in the Local State, the Remote State is enabled.
 - b. If the Calibrator is in the Local With Lockout State, the Remote State With Lockout State is enabled.
2. The Calibrator still handshakes statements over the IEEE-488 interface but the data is ignored and discarded.
3. If the Calibrator is correctly addressed to talk and has data to send (DAV true), it transmits the information even with the REN command line false. If the Calibrator does not have data to transmit, DAV will be false and no data transfers can occur.

Remote States

4-9.

There are two remote states, Remote and Remote with Lockout. In both remote states, the Calibrator is controlled by the IEEE-488 interface, and a remote message appears on the Alphanumeric Display. In remote, the Calibrator sends a Return to Local command any time a front panel key is pressed (unless Remote With Lockout is selected).

REMOTE OPERATION NOTATION AND SYNTAX CONVENTIONS

The only observable difference between the two states is the message that appears on the Alphanumeric Display. In the Remote State, the message REMOTE CONTROL appears in the Alphanumeric Display. In the Remote With Lockout State, the message REMOTE WITH LOCKOUT appears in the Alphanumeric Display.

The REN command line must remain true during program data transfer, or the Calibrator will handshake but ignore the data.

Timing Considerations 4-10.

Timing is an important consideration when writing calibration programs. How much wait time must be allowed to insure that an instrument has executed a message, and the output of that instrument has settled? The Calibrator has an "output settled" bit in the Serial Poll Status Byte (described later in this section) that can generate an interrupt (SRQ) to notify the controller when the Calibrator output has settled within $\pm 5\%$. If the output voltage is not changed (for example, if SOUT 1V is set twice), the second command does not generate an SRQ.

Input Buffer 4-11.

All statements received by the Calibrator from the IEEE-488 interface are stored in a 127-character input buffer. If the Calibrator receives a statement that has more than 127 characters, a "statement too large" error is flagged and the input buffer is cleared. If statements are being sent to the Calibrator faster than the Calibrator can process them, the Calibrator stops the three-wire handshake at Ready For Data Hold off when the input buffer fills.

IEEE-488 Interface Messages and IFC Command Line 4-12.

The IEEE-488 interface messages and the IFC command line are defined in Table 4-2.

NOTATION AND SYNTAX CONVENTIONS 4-13.

Notation and syntax conventions are used in this section. The notation conventions add clarity to the descriptions. The syntax conventions define the grammar of program statements for the Calibrator. Table 4-3 defines the notation and syntax conventions used in this section. Figure 4-2 shows how to interpret syntax diagrams.

INCOMING CHARACTER TRANSFORMATIONS 4-14.

The Calibrator processes all incoming data from the IEEE-488 interface through the following transformations:

1. Bit 8 (DIO8) is ignored so that all data in the Calibrator is 7-bit ASCII only.
2. All lower case characters are changed to upper case.
3. All ASCII characters less than character 32 (space) are discarded, except for characters 10 (LF) and 13 (CR).

CALIBRATOR STATEMENT 4-15.

A Calibrator statement is the minimum executable device dependent message string that can be sent to the Calibrator. No execution takes place until the Calibrator receives a complete statement ended by a terminator. Figure 4-3 shows the syntactical construction allowed for Calibrator statements. In addition to this syntax structure, Calibrator statements must meet the following semantic rules:

Table 4-2. IEEE-488 Interface Messages and IFC Command Line

INTERFACE MNEMONIC	MESSAGE/COMMAND LINE NAME	COMMENTS
DCL	Device Clear	DCL clears the input/output data buffers, unasserts service request, and resets the Calibrator to the power on reset state.
GET	Group Execute Trigger	Handshaken but ignored.
GTL	Go To Local	GTL transfers control of the Calibrator from one of the remote states to one of the local states. See the Remote And Local States material earlier in this section.
IFC	Interface Clear	IEEE-488 Command Line that goes true (1) to place the interface in the idle state.
LLO	Local Lockout	LLO transfers remote/local control of the Calibrator. See the Remote And Local material earlier in this section.
SDC	Selected Device Clear	SDC must be preceded by the correct MLA. If the ATN command line is true, SDC clears the input/output data buffers, unasserts service request, and resets the Calibrator to the power on reset state.
SPE	Serial Poll Enable	If the ATN command line is true, SPE configures the Calibrator for serial poll.
SPD	Serial Poll Disable	If the ATN command line is true, SPD disables serial poll.
PPU	Parallel Poll Unconfigure	Handshaken but ignored.
TCT	Take Control	Handshaken but ignored.
SCG	Secondary Command Group	Handshaken but ignored.

1. A statement must be less than 127 characters in length including the SR2 or SR3 components (counted as one character) of the terminator.
2. A header can have a maximum of five characters.
3. A numeric value must meet the following rules:
 - a. The mantissa must have less than eight significant digits.
 - b. The exponent must be less than two significant digits.
 - c. An integer must be less than 256.
 - d. The absolute value of a numeric must be greater than 1E-12 and less than 1E8.

**REMOTE OPERATION
CALIBRATOR STATEMENT**

Breaking rule 1 causes the Input Buffer to clear when the maximum character limit is reached. Breaking rules 2 or 3 causes the entire statement to be ignored.

Table 4-3. Calibrator Notation and Syntax Conventions

NOTATION/ SYNTAX	MEANING
NOTATION CONVENTIONS	
CR	Carriage Return
LF	Line Feed
SPACE	Space Character
SYNTAX CONVENTIONS	
::=	The symbol to the left of the syntax notation is defined by the symbol(s) to the right of the syntax notation.
< >	The symbol between the brackets can be expanded (modified or defined). Symbols not enclosed by these brackets cannot be expanded.
{ }	The symbol(s) between the brackets can be repeated zero or more times.
[]	The symbol(s) between the brackets is optional.
	The symbols on either side of the syntax notation are logically ORed.

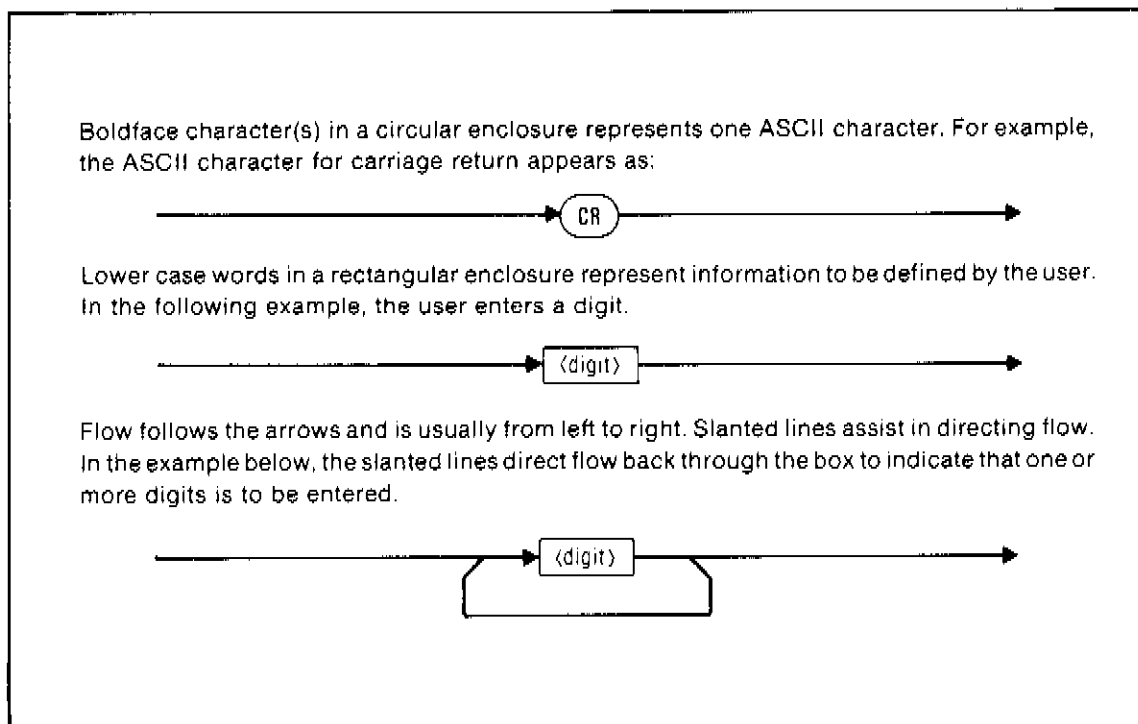

Figure 4-2. Syntax Diagram Interpretation

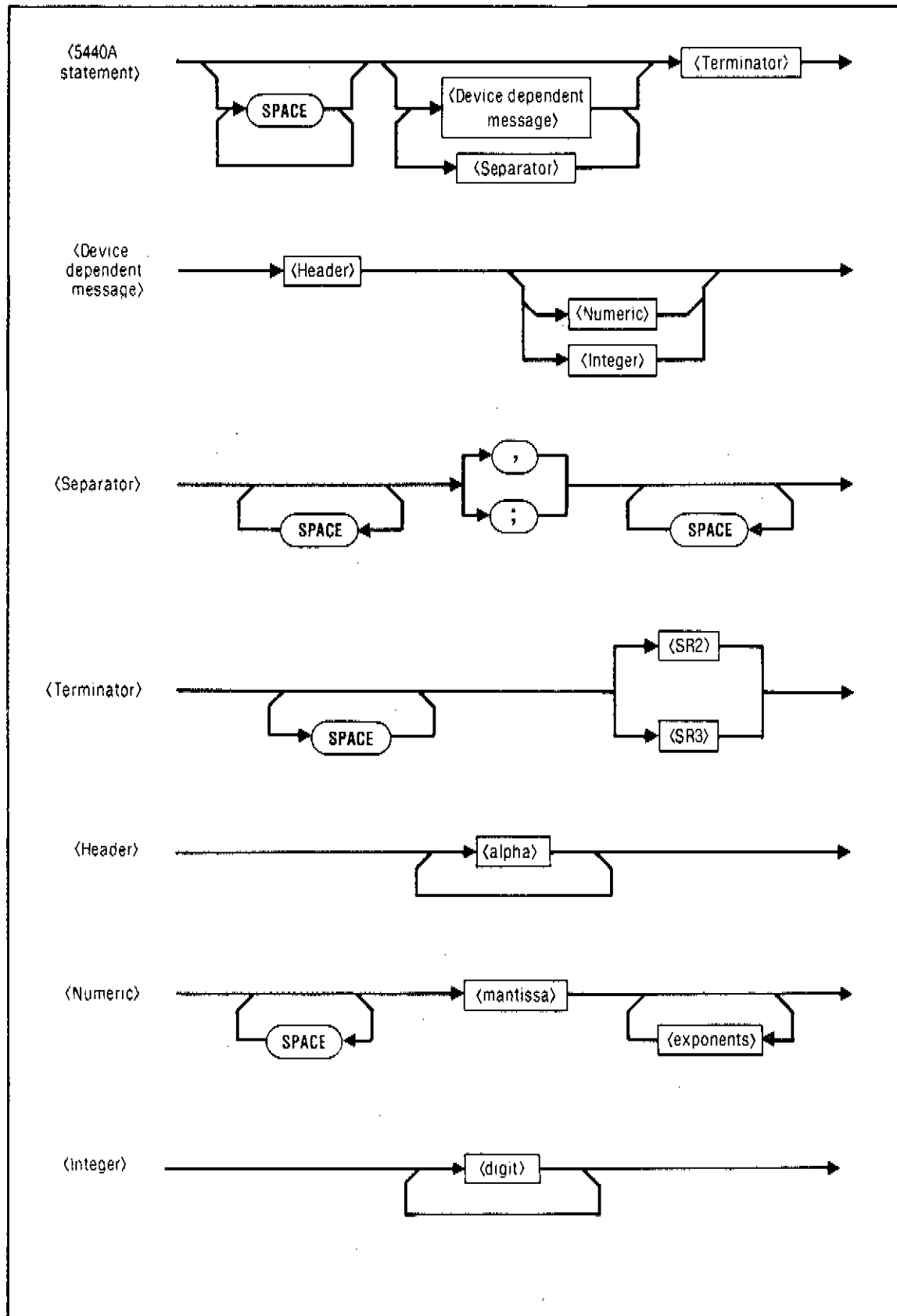

Figure 4-3. Calibrator Statement Syntax

**REMOTE OPERATION
CALIBRATOR STATEMENT**

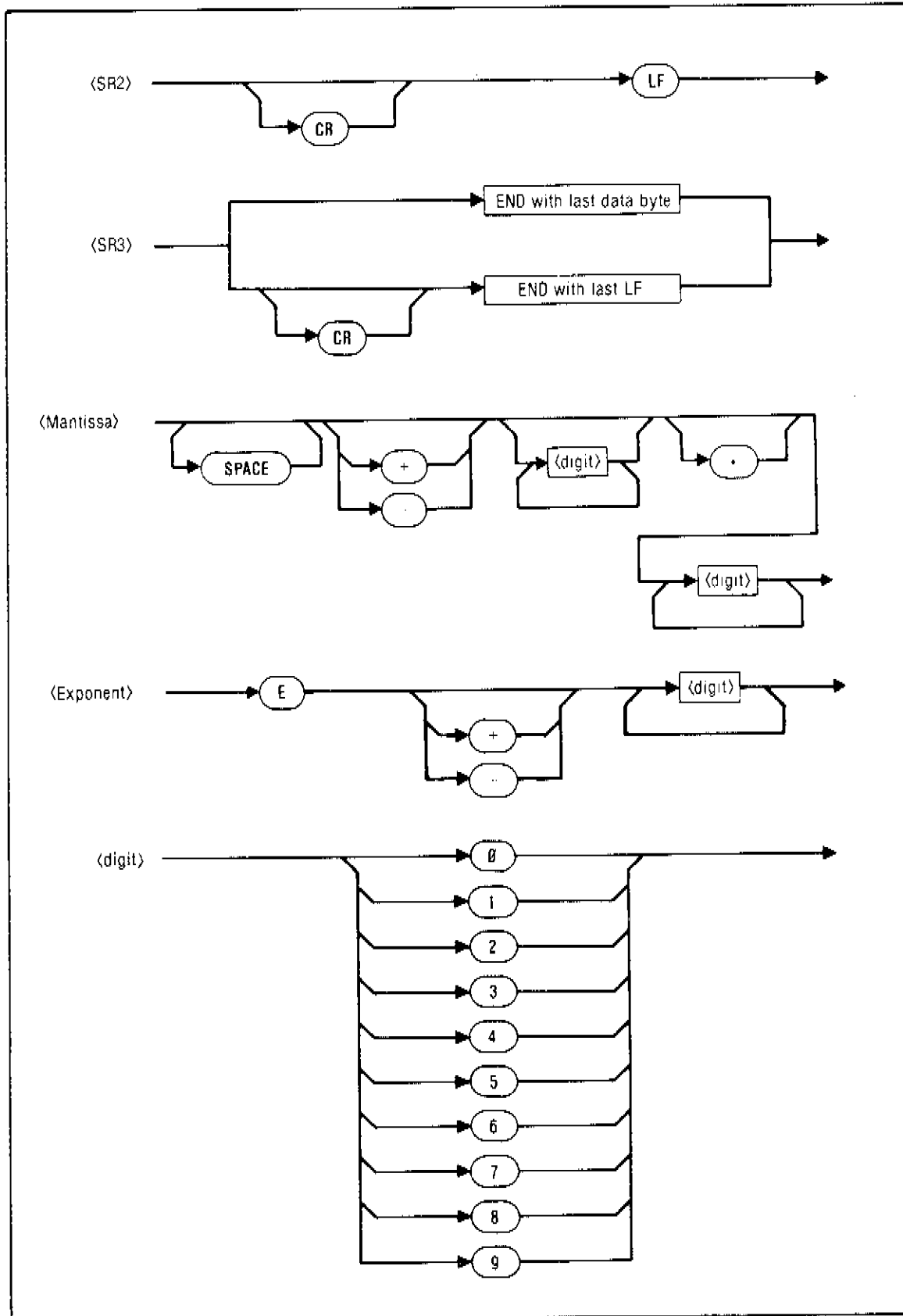

Figure 4-3. Calibrator Statement Syntax (cont)

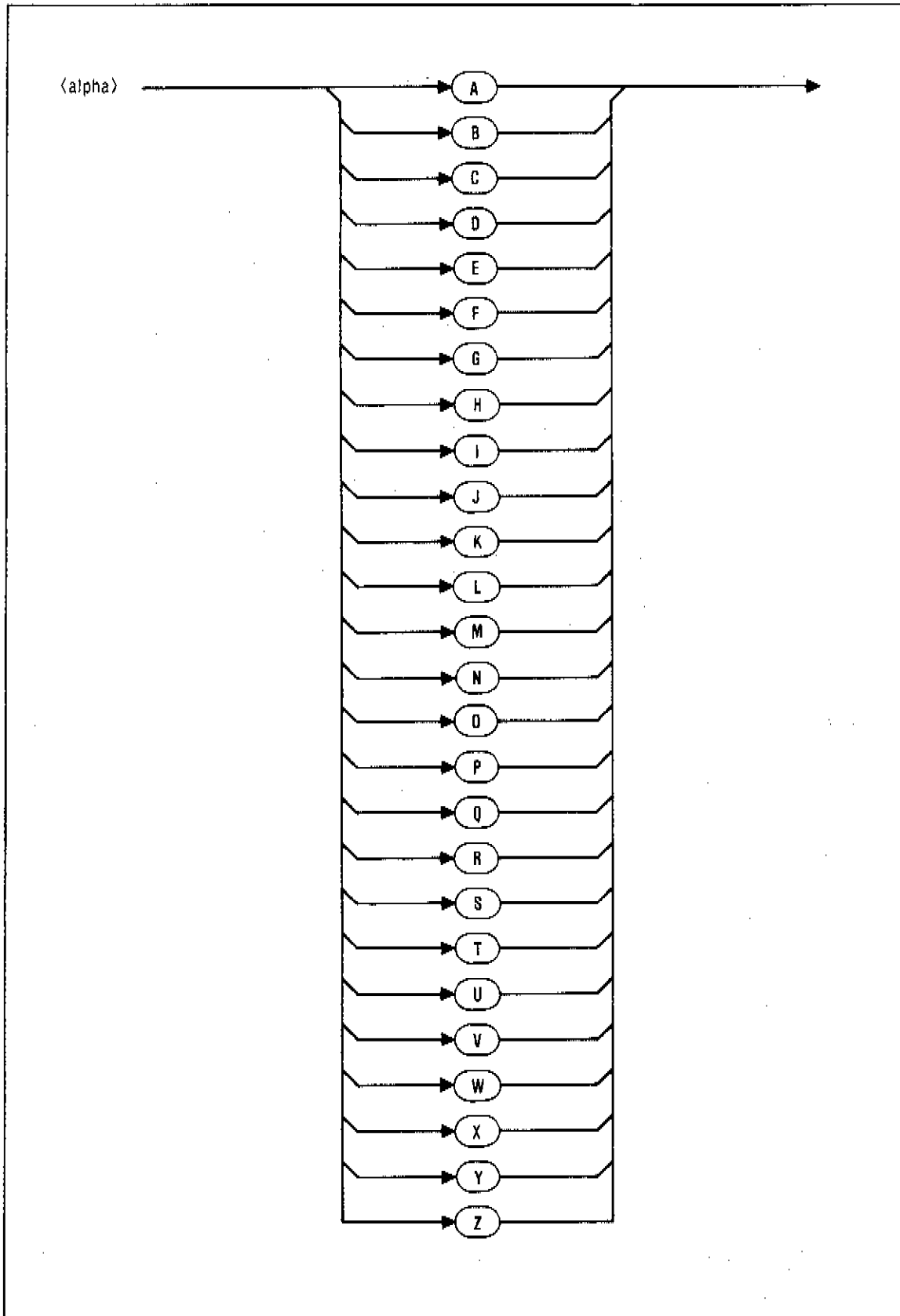

Figure 4-3. Callibrator Statement Syntax (cont)

Message Sequence

4-16.

The sequence of messages in a Calibrator statement is not important, but the messages contained in a statement or the sequence of statements can be important to specific applications.

To understand this, the general structure of Calibrator software must be examined. As Figure 4-4 shows, the software can be viewed from the IEEE-488 interface as having a foreground loop and a background loop with the Setup Status Byte in between. Messages received and sent via the IEEE-488 interface are processed by the foreground loop. Processing takes the same amount of time for every message received. Calibrator setup data, such as the output, is written on the Setup Status Byte immediately.

When the background loop sees that the setup status byte has changed, it begins to alter the Calibrator hardware. Meanwhile, the foreground loop continues to communicate with the IEEE-488 interface. Some operations take the background loop a relatively long time to complete. For example, it takes approximately 10 seconds to change the output level from +1100V to -1100V.

Now the original description of timing considerations can be explained more precisely. The sequence in which messages are arranged within Calibrator statements is unimportant (since the foreground loop processes all messages at the same rate), but the messages contained in a statement or the sequence of statements can be important to specific applications. For example, when the Calibrator output is set above +22V or below -22V, the Calibrator trips to standby as a safety precaution (from high voltages). So, the Operate (OPER) message must be included in the same statement with the Set Output (SOUT) message (for outputs above +22V or below -22V) or the OPER message must be included in the statement following the SOUT message.

DEVICE DEPENDENT MESSAGES

4-17.

The device dependent messages duplicate the Calibrator front panel control functions and report the status of the Calibrator over the IEEE-488 interface. Each message is described in the table at the end of this section.

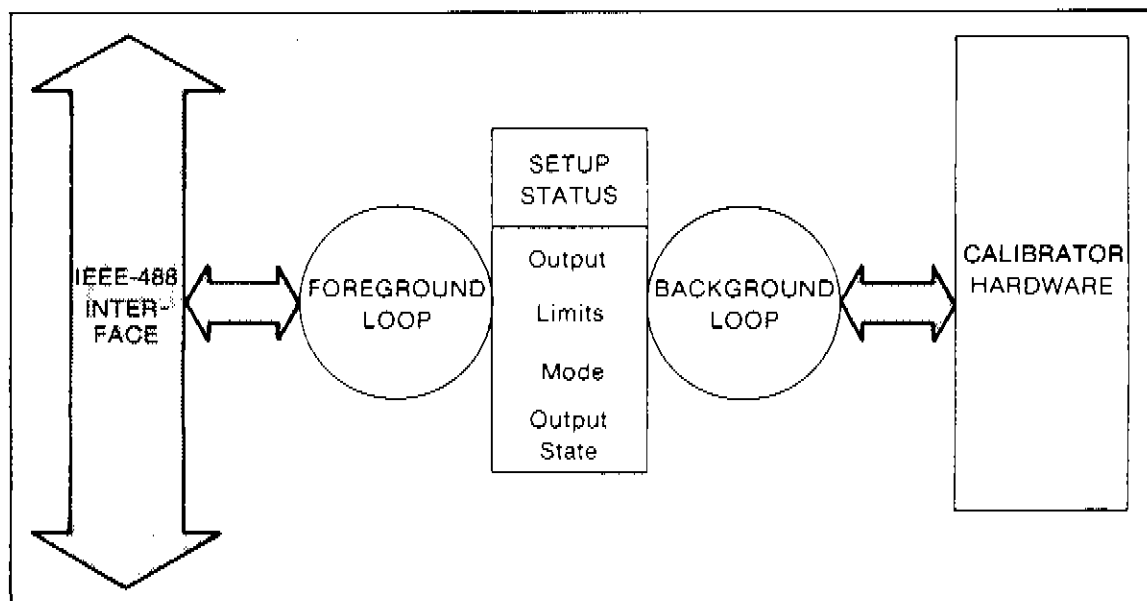

Figure 4-4. Calibrator Software Viewed from the IEEE-488 Interface

The device dependent messages can be divided into two categories: those messages that request a response and those that demand a certain action from the Calibrator (e.g., Set Output). Responses occur in the same order in which the requests were ordered. The following paragraphs provide general information about responses and specific information about the Setup Status Report, the Long Term Operation Report, the Remote Error Report, and the SRQ and Serial Poll operations.

Response Messages

4-18.

The Calibrator sends a message in response to a query message. Responses to messages are sent in the same order that the queries were received. Figure 4-5 shows the syntax of Calibrator response messages. Table 4-4 lists the specific responses to all Calibrator query messages.

The following rules apply to Calibrator response messages:

1. One response is generated for each statement containing queries.
2. One parameter is generated for all request messages except Get Volt Limit (GVLM) and Get Current Limit (GCLM). GCLM can have one or two parameter(s) generated, depending upon the number of limits programmed. GVLM always sends two parameters.
3. The separator is set by the Set Separator (SSEP) message to be either a comma (,) or a semi-colon (;). The default separator is a comma (,).
4. The terminator is set by the Set Terminator (STRM) message. The default terminator is CR END with the last LF .

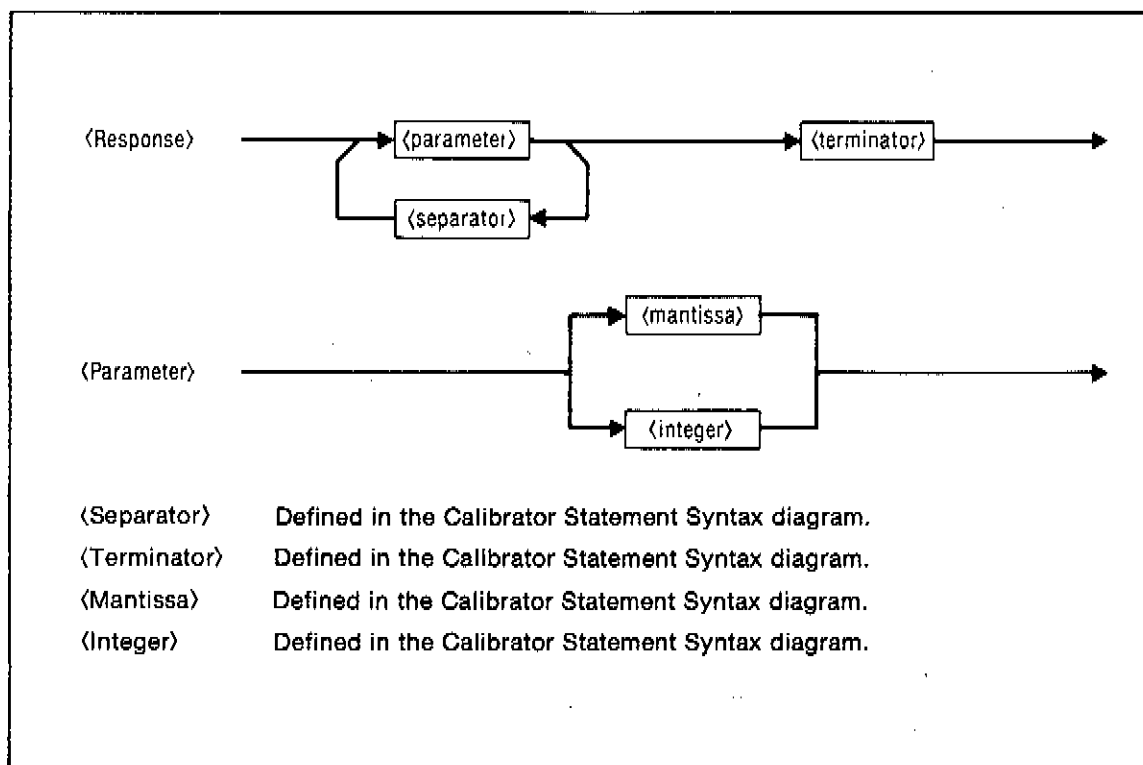

Figure 4-5. Calibrator Response Message Syntax

REMOTE OPERATION
DEVICE DEPENDENT MESSAGES

5. Once a statement with a request message has been received, the Calibrator will not execute additional statements until the Calibrator has sent the response message on the IEEE-488 interface (which should be input by the controller).
6. A mantissa cannot have more than eight significant digits.
7. Integer values must be less than 256.

Setup Status Report

4-19.

When a Get Status (GSTS) message is received, the Calibrator reads the Setup Status Byte and sends the current setup as the sum of the codes shown in Table 4-5. For example, if the Calibrator is in the Voltage Mode using internal sense in Operate, the response would be the number 49 followed by a terminator.

Long Term Operation Report

4-20.

When the Get Doing (GDNG) message is received, the Calibrator sends an integer that indicates which part of what long term operation is being executed. Table 4-6 lists the possible response integers and the corresponding states.

Table 4-4. Responses to Calibrator Request Messages

REQUEST MESSAGE	RESPONSE MESSAGE STRUCTURE
GBDR	<integer>
GCAL	<mantissa>
GCLM Voltage Mode Voltage Boost Mode Current Boost Mode	<mantissa> not allowed <mantissa> (separator) <mantissa>
GDNG	<integer>
GEPF	<integer>
GERR	<mantissa>
GFLR	<mantissa>
GOUT	<mantissa>
GPCT	<mantissa>
GPRF	<mantissa>
GSEP	<integer>
GSPB	<integer>
GSRQ	<integer>
GSTS	<integer>
GTRM	<integer>
GVLM Voltage Mode Voltage Boost Mode Current Boost Mode	<mantissa> (separator) <mantissa> <mantissa> (separator) <mantissa> not allowed
GVRS	<mantissa>

Table 4-5. Setup Status Codes

CODE	CONDITION
1	Voltage Mode*
2	Current Boost Mode*
4	Voltage Boost Mode*
8	Divider on
16	Internal Sense/Not External Sense
32	Operate/Not Standby
64	Internal guard shorted to low
128	Rear Output active

*Mutually exclusive modes

Table 4-6. Long-Term Operation State Codes

CODE	STATE
0	Idle, no state active.
16	Internal calibration, calibrating the Analog to Digital Converter.
32	Internal calibration, zeroing the +10V range.
33	Internal calibration, zeroing the -10V range.
34	Internal calibration, zeroing the +20V range.
35	Internal calibration, zeroing the -20V range.
36	Internal calibration, zeroing the +250V range.
37	Internal calibration, zeroing the -250V range.
38	Internal calibration, zeroing the +1000V range.
39	Internal calibration, zeroing the -1000V range.
48	Internal calibration, gain shift measurement +10V.
49	Internal calibration, gain shift measurement +20V.
50	Internal calibration, gain shift measurement +high voltage.
51	Internal calibration, gain shift measurement -high voltage.
52	Internal calibration, gain shift measurement -20V.
53	Internal calibration, gain shift measurement -10V.
64	External calibration, 10V standard entry. Entry of standard voltage or skip to next range expected.
65	External calibration, 20V standard entry. Entry of standard voltage or skip to next range expected.
66	External calibration, 250V standard entry. Entry of standard voltage or skip to next range expected.
67	External calibration, 1000V standard entry. Entry of standard voltage or skip to next range expected.
68	External calibration, 2V divider standard entry. Entry of standard voltage or skip to next range expected.
69	External calibration, 0.2V divider standard entry. Entry of standard voltage or skip to next range expected.
80	External calibration, 10V null. Increment output, skip to next range, or null expected.
81	External calibration, 20V null. Increment output, skip to next range, or null expected.

REMOTE OPERATION
DEVICE DEPENDENT MESSAGES

Table 4-6. Long-Term Operation State Codes (cont)

CODE	STATE
82	External calibration, 250V null. Increment output, skip to next range, or null expected.
83	External calibration, 1000V null. Increment output, skip to next range, or null expected.
84	External calibration, 2V divider null. Increment output, skip to next range, or null expected.
85	External calibration, 0.2V divider null. Increment output, skip to next range, or null expected.
96	Internal calibration, measuring the n1/n2 ratio.
112	Digital self test, main microprocessor.
113	Digital self test, front panel microprocessor.
114	Digital self test, guard microprocessor.
128	Analog self test, low voltage.
129	Analog self test, high voltage.
130	Analog self test, oven testing.
208	Printing to the printer.
224	Writing to the non-volatile memory.
240	Resetting.

Remote Error Report

4-21.

When an error occurs, the Calibrator sets the appropriate remote error flag. When any remote error flag is set true (1), the Error Condition bit of the Serial Poll Status Byte is set true (1). If the Error Condition bit of the SRQ Mask is also true, then an SRQ interrupt is generated on the IEEE-488 interface.

The IEEE-488 interface controller sends a Get Error (GERR) message to read the error condition. When the GERR message is received, the Calibrator resets all the remote error flags and sends the error status on the IEEE-488 interface as one to three digits followed by a terminator where the digit(s) is the error code. Section 2 provides additional information about operator error codes. The Troubleshooting section of the 5440 Series Service Manual provides additional information about all error codes.

SRQ and Serial Poll

4-22.

All devices connected to the IEEE-488 bus that have SRQ capability can request service from the interface controller. A controller with serial poll capability can then respond by polling the devices one at a time. Polling causes each device to send the binary equivalent of its Serial Poll Status Byte and to clear the Request for Service bit of the Serial Poll Status Byte.

Figure 4-6 shows the Serial Poll Status Byte and the SRQ Mask for the Calibrator. Note that only one bit position is used to request for service; all other bit positions indicate specific events or are not used at all. When one of these events occurs, the corresponding bit position in the Serial Poll Status Byte is set true (1). If the same bit position is true (1) in the SRQ Mask, then the Request for Service bit position in the Serial Poll Status Byte is set true (1) which requests service by the controller. If the bit position in the SRQ Mask for that event is false (0), then the Request for Service bit

position is not affected by the event. For example, bit position 32 of the SRQ Mask must be true (1) for the Calibrator to be able to generate an SRQ interrupt when an error condition occurs.

The Serial Poll Status Byte

4-23.

The following paragraphs provide information about each bit position of the Serial Poll Status Byte (Figure 4-6) that is used. The controller can look at the Serial Poll Status Byte by either serial polling or by sending the Get Serial Poll Byte (GSPB) message. The Calibrator returns the decimal equivalent of the Serial Poll Status Byte.

The Request for Service bit requests service from the controller when set true (1). The bit is reset to 0 by a serial poll.

The Error Condition bit is set true (1) to indicate that an error condition has occurred. The bit position is set false (0) when the controller uses the Get Error (GERR) message to read the error condition. A Request for Service (RSV) is generated on transition from the no error condition to the error condition. The error message can be interpreted using the information in the Error Status Reporting Format.

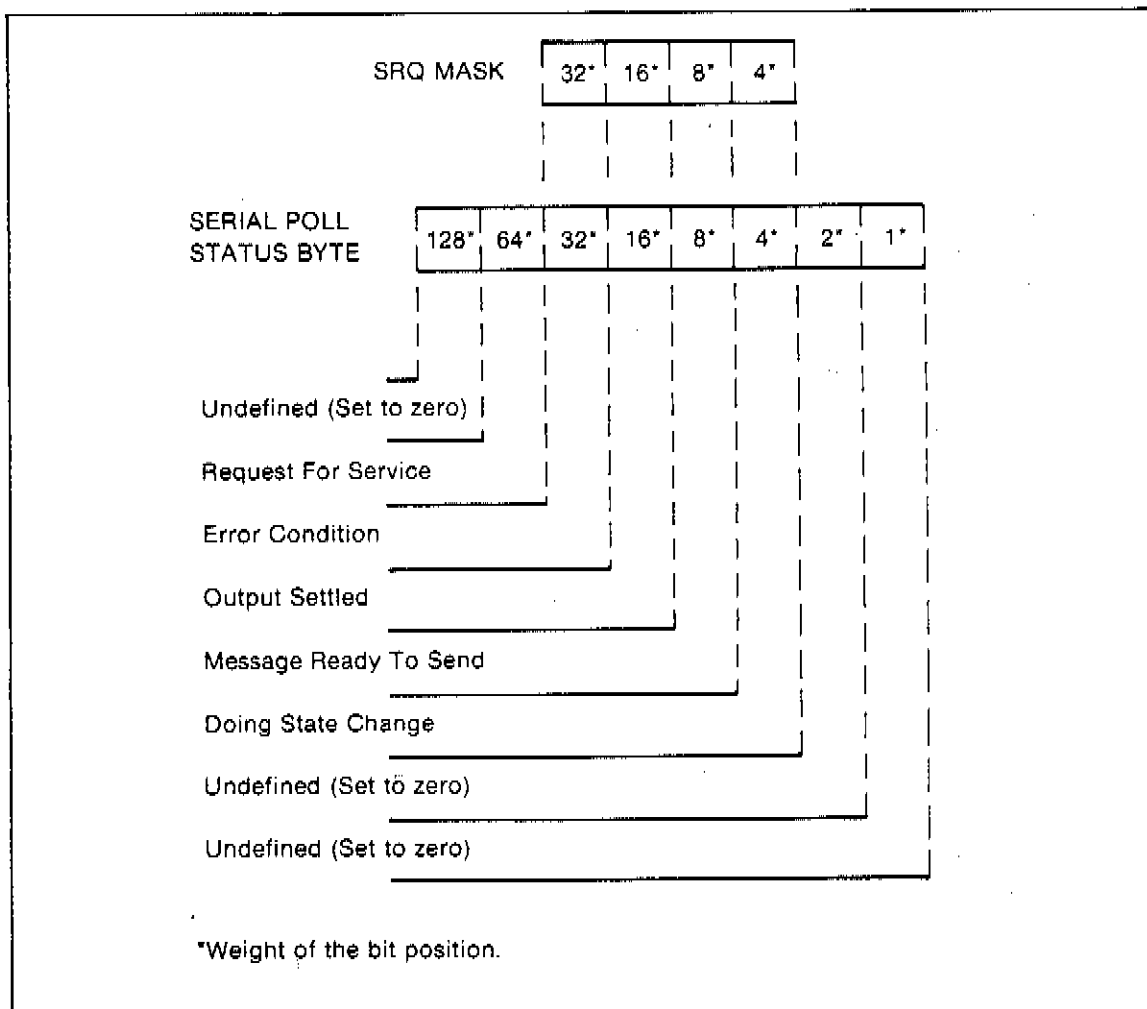

Figure 4-6. SRQ Mask and Serial Poll Status Byte

**REMOTE OPERATION
DEVICE DEPENDENT MESSAGES**

The Output Settled bit is set true (1) when the Calibrator output settles within $\pm 5\%$. The bit is set false (0) when the Calibrator output is changing, but it is the transition to true that causes the SRQ interrupt. To correctly use this feature, prepare the system in advance to wait for the SRQ interrupt.

NOTE

An SRQ is only generated when the output changes. For example, if the output is set at 1V and the user sends 1V over the IEEE-488 interface, no SRQ is generated.

The Message Ready to Send bit is set true (1) when the Calibrator is ready to send a message in response to a query message from the IEEE-488 interface. The bit is set false (0) when the message is sent. If another message is waiting to be sent, the bit is immediately set true (1) and the Request for Service bit is set true (1). This insures that there is a separate SRQ for each message waiting to be sent.

The Doing State Change bit is set true (1) whenever the Calibrator changes its present doing state. A doing state is part of a long term operation such as an Internal Calibration. The bit is set false (0) when the IEEE-488 interface controller sends the Get Doing (GDNG) message and a Request for Service is generated on the transition from a zero to a one.

The SRQ Mask

4-24.

In order for a bit position of the Serial Poll Status Byte to affect the Request for Service bit (and thereby request service from the IEEE-488 interface controller), the corresponding bit position of the SRQ Mask must be true (1). For example, bit position 32 of the SRQ Mask must be true (1) for the Calibrator to be able to generate an SRQ interrupt when an error condition occurs. The bit positions of the SRQ Mask can all be set false (0) or can be individually set true (1) using the Set Service Request (SSRQ) message.

Device Dependent Message Summary Table

4-25.

Table 4-7 lists and defines all the device dependent messages for the Calibrator.

Table 4-7. 5440B/5442A Device Dependent Messages

MESSAGE	COMMENT
RESET RESET	The statement being executed is aborted and the Calibrator enters the state described for the RESET key in Section 3.
SET SEPARATOR AND TERMINATOR Set Separator SSEP (integer)	Have the Calibrator recognize the ASCII character(s) defined by the numeric as symbols that separate device dependent messages in Calibrator statements. The default separator is a comma (.). The (numeric) can be one of two digits: 0 = , 1 = ;

Table 4-7. 5440B/5442A Device Dependent Messages (cont)

MESSAGE	COMMENT
Get Separator GSEP Set Terminator STRM (integer) Get Terminator GTRM	Have the Calibrator send the selected terminator on the IEEE-488 interface. Terminate messages sent from the Calibrator with the terminator symbol defined by the numeric as follows (CR END occurred with the last LF is the default terminator): 0 = END occurred with the last data byte 1 = CR END occurred with the last LF 2 = END occurred with the last LF 3 = CR LF 4 = LF Have the Calibrator send the selected terminator in the IEEE-488 interface.
MODE SELECTION Boost Current BSTC Boost Current BSTV Boost Off BSTO	Same as pressing the BOOST (DATA ENTRY) key and the CURR BOOST soft key: enable Current Boost operation. Disable Voltage Boost Mode and Voltage Mode operation. Same as pressing the BOOST (DATA ENTRY) key and the VOLT BOOST soft key: enable Voltage Boost operation. Disable Current Boost and Voltage Mode operation. Disable boost operation. Enable Voltage Mode operation.
OUTPUT Set Output SOUT (numeric) Get Output GOUT Increment Output INCR (numeric) Set Reference SREF Get Reference GREF	Set the Calibrator output to the value of (numeric). The units are amps in Current Boost Mode and volts in both Voltage Mode and Voltage Boost Mode. SOUT does not set the reference. To set the reference use SOUT (numeric) followed by SREF. Have the Calibrator send the output value on the IEEE-488 interface. Add the (numeric) to the output value. Store the current output as the error mode reference. Set the Calibrator output to the error mode reference.
OUTPUT STATE Operate OPER Standby STBY	Same as pressing the OPR/STANDBY (OUTPUT STATE) key so that it is lit: the output of the Calibrator is available at the appropriate terminals. Same as pressing the OPR/STANDBY (OUTPUT STATE) key so that it is not lit: the output of the Calibrator is removed from the output terminals.

**REMOTE OPERATION
DEVICE DEPENDENT MESSAGES**

Table 4-7. 5440B/5442A Device Dependent Messages (cont)

MESSAGE	COMMENT
External Sense ESNS (cont)	Same as using the SENSE (OUTPUT STATE) key so that it is lit: the Calibrator uses the external sensing circuit.
Internal Sense ISNS	Same as pressing the SENSE (OUTPUT STATE) key so that it is not lit: the Calibrator uses the internal sense circuit.
External Guard EGRD	Same as pressing the GUARD (OUTPUT STATE) key so that it is lit: the Calibrator uses the external guard circuit.
Internal Guard IGRD	Same as pressing the GUARD (OUTPUT STATE) key so that it is not lit: the Calibrator uses the internal guard circuit.
Enable Divider DIVY	Turn on the output divider.
Disable Divider DIVN	Turn off the output divider.
LIMIT	
Set Voltage Limit SVLM (numeric)	<p>Same as pressing the LIMIT (DATA ENTRY) key then the VOLT LIMITS soft key: the voltage limit is set to the value of the (numeric).</p> <p>During Voltage Mode or Voltage Boost Mode operation, one entry is made to set the positive voltage limit and one entry is made to set the negative voltage limit. The polarity of (numeric) determines which limit is set.</p> <p>Set Voltage Limits is not recognized during Current Boost Mode operation.</p>
LIMIT Get Voltage Limit GVLM	Have the Calibrator send the voltage limit(s) on the IEEE-488 interface.
Set Current Limit SCLM (numeric)	<p>Same as pressing the LIMIT (DATA ENTRY) key then the CURR LIMITS soft key: the current limit is set to the value of the (numeric).</p> <p>During Voltage Mode operation, the current limit is a current trip specification which is the absolute value of the (numeric).</p> <p>During Current Boost Mode operation, one entry is made to set the positive limit and one entry is made to set the negative entry. The polarity of (numeric) determines which limit is set.</p> <p>Set Current Limits is not recognized during Voltage Boost Mode Operation.</p>
Get Current Limit GCLM	Have the Calibrator send the current limit(s) on the IEEE-488 interface.

Table 4-7. 5440B/5442A Device Dependent Messages (cont)

MESSAGE	COMMENT
<p>ERROR</p> <p>Set Tolerance Floor SFLR <numeric></p> <p>Get Tolerance Floor GFLR</p> <p>Set Percent of Reference SPRF <numeric></p> <p>Get Percent of Reference GPRF</p> <p>Get Percent Error GPCT</p>	<p>Same as pressing the ERROR MODE (DATA ENTRY) then the ENTER TOL soft key: the tolerance floor is set to the fractional value of the <numeric>.</p> <p>Have the Calibrator send the tolerance floor on the IEEE-488 interface.</p> <p>The percentage of error specification is set to the value of <numeric>.</p> <p>Have the Calibrator send the percent of reference on the IEEE-488 interface.</p> <p>Have the Calibrator send the calculated percent error of the Calibrator output from the reference on the IEEE-488 interface as a fraction.</p>
<p>STATUS AND ERROR REPORTING (see the Report Format material)</p> <p>Get Status GSTS</p> <p>Get Error GERR</p> <p>Get Version GVRS</p> <p>Get Doing State GDNG</p> <p>Get % Error Pass/Fail GEPF</p>	<p>Have the Calibrator send the setup status on the IEEE-488 interface in the Setup Status Report Format.</p> <p>Have the Calibrator send the error status on the IEEE-488 interface. See Section 2 for additional error code information.</p> <p>Have the Calibrator send the version number of the Calibrator software on the IEEE-488 interface. The version number is sent in the format dd.dd where dd.dd is the software version number.</p> <p>Have the Calibrator report what it's doing during long operations. A long operation is any operation that takes more than 5 seconds.</p> <p>Have the Calibrator send the % Error Pass/Fail on the IEEE-488 interface as a 1 for pass or a 0 for fail.</p>
<p>CALIBRATION</p> <p>Calibration Internal CALI</p> <p>Calibration External CALE</p> <p>Calibration Standard CSTD <numeric></p> <p>Calibrator Nulled CNUL</p> <p>Calibration Skip Range CSKP</p> <p>Get Calibration Constant GCAL <integer></p>	<p>Start the Internal Calibration Procedure.</p> <p>Start the External Calibration Procedure.</p> <p>The calibration standard voltage for the external calibration is the value of the <numeric>.</p> <p>The calibrator is nulled with the external voltage standard.</p> <p>Skip the present external calibration range.</p> <p>Have the Calibrator send the calibration constant identified by <numeric> on the IEEE-488 interface.</p>

**REMOTE OPERATION
DEVICE DEPENDENT MESSAGES**

Table 4-7. 5440B/5442A Device Dependent Messages (cont)

MESSAGE	COMMENT																																
<p>SELF TESTS</p> <p>Test Analog TSTA</p> <p>Test Digital TSTD</p> <p>Test High Voltage TSTH</p>	<p>Execute the Analog Self-test. If the test fails, the Calibrator generates an error code on the IEEE-488 interface. If the test passes, there is no response. [The result returned by the GDNG (Get Doing State) query at the completion of the self test will be instrument idle.]</p> <p>Execute the Digital Self-test. If the test fails, the Calibrator generates an error code on the IEEE-488 interface. If the test passes, there is no response. [The result returned by the GDNG (Get Doing State) query at the completion of the self test will be instrument idle.]</p> <p style="text-align: center;">WARNING</p> <p style="text-align: center;">TO AVOID SHOCK HAZARD DURING THE HIGH VOLTAGE SELF TEST, NEVER MAKE ELECTRICAL CONTACT WITH THE OUTPUT HI OR SENSE HI TERMINALS OF THE CALIBRATOR.</p> <p>Execute the High Voltage Self-test. If the test fails, the Calibrator generates an error code on the IEEE-488 interface. If the test passes, there is no response. [The result returned by the GDNG (Get Doing State) query at the completion of the self test will be instrument idle.]</p>																																
<p>BAUD RATE</p> <p>Set Baud Rate SBDR (integer)</p> <p>Get Baud Rate GBDR</p>	<p>Set the Calibrator baud rate to the value of the integer where the integer can be any decimal number from 0 through 12:</p> <table border="1" data-bbox="713 1258 1383 1510"> <thead> <tr> <th>INTEGER</th> <th>BAUD RATE</th> <th>INTEGER</th> <th>BAUD RATE</th> </tr> </thead> <tbody> <tr> <td>0</td> <td>50</td> <td>7</td> <td>600</td> </tr> <tr> <td>1</td> <td>75</td> <td>8</td> <td>1200</td> </tr> <tr> <td>2</td> <td>110</td> <td>9</td> <td>1800</td> </tr> <tr> <td>3</td> <td>134.5</td> <td>10</td> <td>2400</td> </tr> <tr> <td>4</td> <td>150</td> <td>11</td> <td>4800</td> </tr> <tr> <td>5</td> <td>200</td> <td>12</td> <td>9600</td> </tr> <tr> <td>6</td> <td>300</td> <td></td> <td></td> </tr> </tbody> </table> <p>Send the Calibrator baud rate on the IEEE-488 interface.</p>	INTEGER	BAUD RATE	INTEGER	BAUD RATE	0	50	7	600	1	75	8	1200	2	110	9	1800	3	134.5	10	2400	4	150	11	4800	5	200	12	9600	6	300		
INTEGER	BAUD RATE	INTEGER	BAUD RATE																														
0	50	7	600																														
1	75	8	1200																														
2	110	9	1800																														
3	134.5	10	2400																														
4	150	11	4800																														
5	200	12	9600																														
6	300																																
<p>MONITOR</p> <p>Monitor Yes MONY</p> <p>Monitor No MONN</p>	<p>Turn the RS-232-C monitor on. All internal calibration and analog test data is sent out on the RS-232-C interface.</p> <p>Turn the RS-232-C monitor off.</p>																																

Table 4-7. 5440B/5442A Device Dependent Messages (cont)

MESSAGE	COMMENT
<p>SERVICE REQUEST Set Service Request SSRQ <integer></p>	<p>Set the positions in the SRQ Mask (see the SRQ and Serial Poll material in this section) to generate an interrupt on the conditions defined by the <integer>. The integer is the sum of the following codes (the default value is 0):</p> <ul style="list-style-type: none"> 0 = Never generate an interrupt. 4 = Interrupt doing a long term operation (5 seconds or longer). 8 = Interrupt when the requested message is ready to send. 16 = Interrupt when the output is settled. 32 = Interrupt when there is an error condition.
<p>Recall Service Request GSRQ</p>	<p>Have the Calibrator send the SRQ Mask on the IEEE-488 interface.</p>
<p>Get Serial Poll Status Byte GSPB</p>	<p>Have the Calibrator send the decimal equivalent of Serial Poll Status Byte. Also see the SRQ and Serial Poll material in this section.</p>

Section 5

The RS-232-C Interface

INTRODUCTION

5-1.

This section describes how to setup and use the Calibrator's RS-232-C interface. The RS-232-C interface is designed in accordance with the EIA standard RS-232-C. The RS-232-C interface allows you to print or display the Calibrator's Internal Calibration results, self-test results, and other data, using a standard printer or video monitor.

RS-232-C SPECIFICATIONS

5-2.

The RS-232-C specifications for the Calibrator are listed in Table 5-1.

Table 5-1. RS-232-C Specifications

FUNCTION	COMMENTS
Signal Configuration	Modem, full duplex
Serial Output	Pin 3 on the rear panel RS-232-C connector
Serial Input	Pin 2 on the rear panel RS-232-C connector
Data Terminal Ready (DTR-handshake line)	Pin 20 on the rear panel RS-232-C connector DTR-handshake line must be set true in order for the Calibrator to transmit serial information. At present this is accomplished by tying DTR to DSR on the shorting plug located on the rear panel. The DTR signal may be also used as a "ready" signal from the user's printer but the user must cut the wire that connects pins 4 and 11 on the shorting plug.
Data Set Ready (DSR-handshake line)	Pin 6 on the rear panel RS-232-C connector The DSR output is used to indicate that the Calibrator is connected.
Signal Ground	Pin 7 on the rear panel RS-232-C connector
Chassis (earth ground)	Pin 1 on the rear panel RS-232-C connector The user may change the pin location by rewiring the shorting plug.
Stall and Unstall	Supported. The Stall command (DC3 or 13 HEX) can be sent by the printer to stop the Calibrator data output until the Unstall command DC1 or 11 HEX) is received.

CONNECTING TO THE RS-232-C PORT

5-3.

The following steps must be taken to connect the Calibrator to a printer or video terminal using the RS-232-C port. Each of these steps is explained in the next paragraphs.

1. Properly configure the RS-232-C Shorting plug.
2. Set the baud rate.
3. Select the proper RS-232-C cable.

Configuring the RS-232-C Shorting Plug

5-4.

The RS-232-C Shorting Plug connects the rear panel RS-232-C Connector to the RS-232-C interface circuitry in the Calibrator. The shorting plug allows you to reconfigure the pin-outs of the RS-232-C Connector to make it compatible with certain printers.

Figure 5-1 shows how the RS-232-C Shorting Plug is wired at the factory. It may be necessary to change some of the wires in the Shorting Plug in order for a particular printer to work properly with the Calibrator.

Setting the Baud Rate

5-5.

The Calibrator can be set to any one of the following baud rates: 50, 75, 110, 134, 150, 200, 300, 600, 1200, 1800, 2400, 4800, or 9600 baud. The baud rate of the Calibrator is set to 2400 at the factory. To set a new baud rate, use the following procedure:

1. Press the SVCE (DATA ENTRY) key, then press the PORT SERV soft key, and then press the RS232 BAUD soft key.

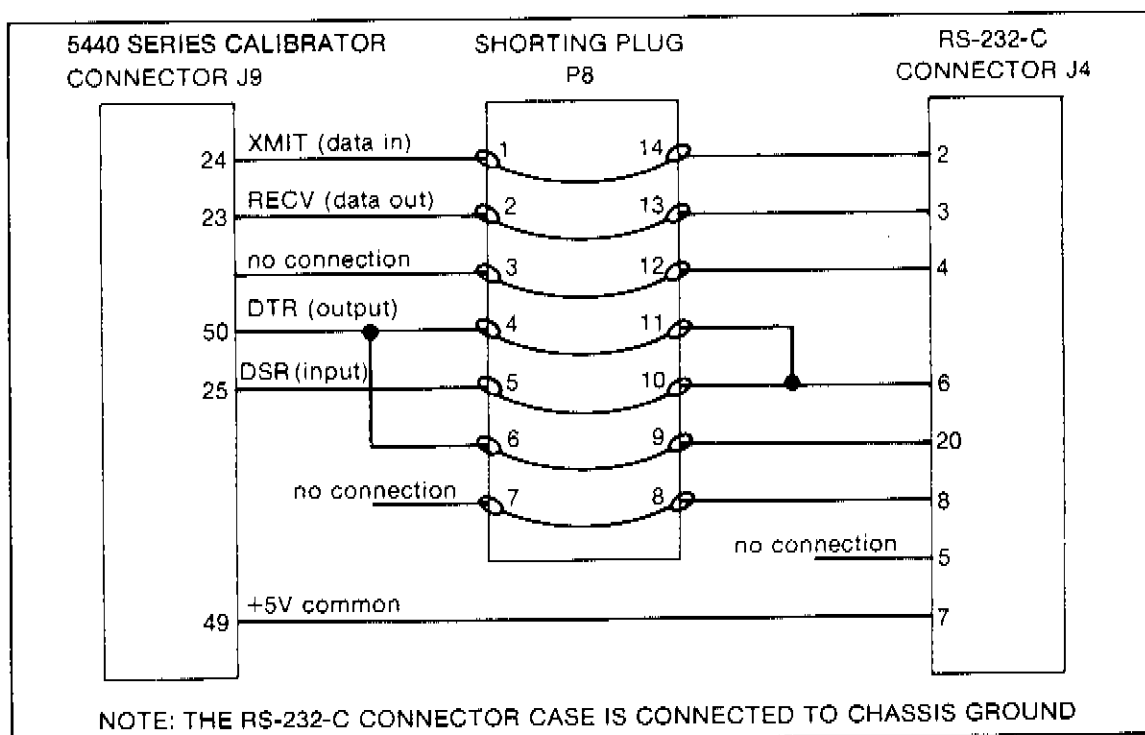

Figure 5-1. RS-232-C Shorting Plug

- The following menu appears on the Alphanumeric Display:

SLOWER 2400 FASTER

RS232 BAUD RS232

The default baud rate stored in nonvolatile memory is 2400. If another rate is stored, that rate will be displayed.

- To increase the baud rate, press the soft key directly below the FASTER menu heading on the Alphanumeric Display. To decrease the baud rate, press the soft key directly below the SLOWER menu heading on the Alphanumeric Display. The new baud rate is updated as you press the soft keys and appears in the upper center of the Alphanumeric Display.
- Press the center soft key. The following message appears on the Alphanumeric Display:

WRITING TO NV MEMORY WAIT

- When the Calibrator returns to its previous operating state, the new baud rate has been set, and stored in non-volatile memory.

RS-232-C Accessory Cables

5-6.

There are several RS-232-C accessory cables that are designed to be used with the Calibrator and other Fluke equipment. Cables are listed with other accessories in Section 1.

RS-232-C OPERATION

5-7.

Once the printer or monitor is properly connected to the Calibrator (and the baud rate has been set), the Calibrator sends data to the peripheral device. Sections 3 and 4 describe front panel and IEEE-488 operations that affect the type of data sent on the RS-232-C interface. Example printouts are shown in Section 3.

RS-232-C DATA FORMAT

5-8.

The data format for the RS-232-C interface is as follows:

BIT	DESCRIPTION
0	Start Bit
2-9	Data Bits (eight)
-	No parity bit
10	Stop Bit

Section 6

Options and Accessories

INTRODUCTION

6-1.

This section describes the options and accessories that are available for the 5440 Series Calibrators. Options are supported by simplified schematics in text and by the complete schematics in Section 10.

OPTIONAL REAR PANEL OUTPUT TERMINALS (5442A ONLY)

6-2.

The 5442A-01 Rear Panel Output Terminals option allows you to make calibration connections from the rear panel of the 5442A. This is especially useful when connecting instruments in systems applications.

Installation requires access to the interior of the Calibrator and should be performed only at Fluke Service Centers.

ADDITIONAL PROCEDURE STORAGE MODULE (5440B ONLY)

6-3.

The 5440A-7001 Additional Procedure Storage Module provides additional non-volatile storage for calibration sequences you have written. Additional storage modules allow you to build a library of calibration procedures for your needs.

LOW THERMAL EMF PLUG-IN CABLES

6-4.

The 5440A-7002 Low Thermal EMF Plug-In Cables are three special-length, shielded cables. The cables are constructed to minimize thermal emf in the connections between the Calibrator output and the input of the device the Calibrator is driving.

The cables should be stored in an area that is free from potential contaminants (e.g., dust, grease, excessive humidity, etc.). To prolong the life of the cables, store the cables in loose coils, not bundles.

LOW THERMAL EMF SPADE-LUG CABLES

6-5.

The 5440A-7003 Low Thermal EMF Spade-lug Cables come in three sizes. They are similar to the Low Thermal EMF Plug-In Cables, except that they have spade-lugs terminators instead of plug-in terminators.

ACCESSORY CABLES

6-6.

Several accessory cables are available to connect the Calibrator to specific devices. Each cable is described below.

OPTIONS AND ACCESSORIES
ACCESSORY CABLES

1780 RS-232-C Cable

6-7.

The Y1707 Cable is two meters long and is intended to connect the Calibrator to the Fluke 1780A Infotouch Display. The cable connects to the RS-232-C interface on the Calibrator.

5205A Interface Cable (5440B Only)

6-8.

The Y5001 Interface Cable connects 5440B to the Fluke 5205A Precision Power Amplifier for voltage boost operation. The cable is 0.7 meters long and has two connectors at each end. At each end, one connector is for digital control signals and one connector is for the analog reference voltage output from the Calibrator.

5220A Interface Cable (5440B Only)

6-9.

The Y5002 Interface Cable connects the 5440B to the Fluke 5220A Transconductance Amplifier current boost operation. The cable is 0.7 meters long and has two connectors at the 5440B end and a single connector at the 5220A end. Digital control signals are carried over one cable, and the analog reference voltage output of the Calibrator is carried over the other cable.

Armored IEEE-488 Interface Cables (Y8021, Y8022, Y8023)

6-10.

These three cables connect the Calibrator to any IEEE-488 compatible device. The cables provide three different lengths: 1 meter for the Y8021, 2 meters for the Y8022, and 4 meters for the Y8023.