

1550

MegOhmMeter

Calibration Manual

Limited Warranty and Limitation of Liability

Each Fluke product is warranted to be free from defects in material and workmanship under normal use and service. The warranty period is two years and begins on the date of shipment. Parts, product repairs, and services are warranted for 90 days. This warranty extends only to the original buyer or end-user customer of a Fluke authorized reseller, and does not apply to fuses, disposable batteries, or to any product which, in Fluke's opinion, has been misused, altered, neglected, contaminated, or damaged by accident or abnormal conditions of operation or handling. Fluke warrants that software will operate substantially in accordance with its functional specifications for 90 days and that it has been properly recorded on non-defective media. Fluke does not warrant that software will be error free or operate without interruption.

Fluke authorized resellers shall extend this warranty on new and unused products to end-user customers only but have no authority to extend a greater or different warranty on behalf of Fluke. Warranty support is available only if product is purchased through a Fluke authorized sales outlet or Buyer has paid the applicable international price. Fluke reserves the right to invoice Buyer for importation costs of repair/replacement parts when product purchased in one country is submitted for repair in another country.

Fluke's warranty obligation is limited, at Fluke's option, to refund of the purchase price, free of charge repair, or replacement of a defective product which is returned to a Fluke authorized service center within the warranty period.

To obtain warranty service, contact your nearest Fluke authorized service center to obtain return authorization information, then send the product to that service center, with a description of the difficulty, postage and insurance prepaid (FOB Destination). Fluke assumes no risk for damage in transit. Following warranty repair, the product will be returned to Buyer, transportation prepaid (FOB Destination). If Fluke determines that failure was caused by neglect, misuse, contamination, alteration, accident, or abnormal condition of operation or handling, including overvoltage failures caused by use outside the product's specified rating, or normal wear and tear of mechanical components, Fluke will provide an estimate of repair costs and obtain authorization before commencing the work. Following repair, the product will be returned to the Buyer transportation prepaid and the Buyer will be billed for the repair and return transportation charges (FOB Shipping Point).

THIS WARRANTY IS BUYER'S SOLE AND EXCLUSIVE REMEDY AND IS IN LIEU OF ALL OTHER WARRANTIES, EXPRESS OR IMPLIED, INCLUDING BUT NOT LIMITED TO ANY IMPLIED WARRANTY OF MERCHANTABILITY OR FITNESS FOR A PARTICULAR PURPOSE. FLUKE SHALL NOT BE LIABLE FOR ANY SPECIAL, INDIRECT, INCIDENTAL OR CONSEQUENTIAL DAMAGES OR LOSSES, INCLUDING LOSS OF DATA, ARISING FROM ANY CAUSE OR THEORY.

Since some countries or states do not allow limitation of the term of an implied warranty, or exclusion or limitation of incidental or consequential damages, the limitations and exclusions of this warranty may not apply to every buyer. If any provision of this Warranty is held invalid or unenforceable by a court or other decision-maker of competent jurisdiction, such holding will not affect the validity or enforceability of any other provision.

Fluke Corporation
P.O. Box 9090
Everett, WA 98206-9090
U.S.A.

Fluke Europe B.V.
P.O. Box 1186
5602 BD Eindhoven
The Netherlands

Visit Fluke's web site at: www.fluke.com

Table of Contents

Title	Page
Introduction	1
Contacting Fluke	2
Symbols	2
Safety Information.....	3
Required Equipment.....	4
Performance Test Procedure.....	5
Button Test.....	5
Display Test	5
Flash Test	6
Charging Test.....	6
Insulation Accuracy Test.....	6
Output Voltage Test	7
Short Circuit Current Test.....	7
Voltage Measurement Accuracy	8
Calibration Procedure	8
Interface Connection	8
Instrument Setup	9
Normalizing the HV Probe and Digital Multimeter.....	9
HV Calibration.....	10
Current Calibration.....	10
Charge Calibration	10
Additional Procedures	11
Battery Calibration (Calibrate Battery).....	11
Install Default Opvars (Default Opvars).....	11
Dump Opvars (Dump Opvars).....	11
Dump Raw ADC Readings (Diagnostics).....	11
Battery Replacement Procedure	11
Disassembly	12
Re-assembly	13
Replacing the Guard Fuse	14
Cleaning.....	15
Replacement Parts/Accessories	15
Specifications	16
General Specifications	16
Electrical Specifications.....	17

List of Tables

Table	Title	Page
1.	Symbols	2
2.	Required Equipment	4
3.	Insulation Accuracy Test	6
4.	Output Voltage Test.....	7
5.	Short Circuit Current Test.....	7
6.	Voltage Measurement Test	8
7.	Replacement Parts.....	15

List of Figures

Figure	Title	Page
1.	Display	5
2.	IR Port on the MegOhmMeter	8
3.	1550 Disassembly	13
4.	Replacing the Guard Fuse	14

MegOhmMeter

Introduction

Warning

- **The information provided in this manual is for qualified personnel only.**
- **To avoid electrical shock or injury, do not perform the verification tests or calibration procedures described in this manual unless qualified to do so.**
- **Before using or servicing the MegOhmMeter, refer to Safety Information.**

The *Calibration Manual* for the 1550 MegOhmMeter (hereafter referred to as "the MegOhmMeter") provides the following information.

- Fluke Contact Information
- Precautions and Safety Information
- Performance Test Procedures
- Calibration Procedure
- Battery Replacement Procedure
- Replaceable Parts/Accessories
- Specifications

For complete operating instructions and additional safety information, refer to the *1550 Users Manual* P/N 1642871.

Contacting Fluke

To contact Fluke for product information, operating assistance, service, or to get the location of the nearest Fluke distributor or Service Center, call:

1-888-99FLUKE (1-888-993-5853) in U.S.A.

1-800-36-FLUKE (1-800-363-5853) in Canada

+31-402-678-200 in Europe

+81-3-3434-0181 Japan

+65-738-5655 Singapore

+1-425-446-5500 from other countries

Address correspondence to:











Fluke Corporation	Fluke Europe B.V.
P.O. Box 9090,	P.O. Box 1186,
Everett, WA 98206-9090	5602 BD Eindhoven
USA	The Netherlands

Visit Fluke's web site at: www.fluke.com.

Symbols

Symbols on the MegOhmMeter and in the manual are explained in Table 1.

Table 1. Symbols

	Conforms to European Union standards.
	Underwriter' Laboratories, Inc.
	TÜV Product Services. Technischer Überwachungs Verein.
	Conforms to Canadian Standards Association requirements.
	Risk of danger. Important information. See Manual.
	Potentially hazardous voltage
	Fuse
	Equipment protected by double or reinforced insulation.
	Interference is present. Displayed value might be outside of specified accuracy.
	Recycle
	Do not mix with solid waste stream. Dispose using a qualified recycler or hazardous material handler.
CAT III	Overvoltage (Installation) Category III, Pollution Degree 2 per IEC1010-1 refers to the level of Impulse Withstand Voltage protection provided. Typical locations include: mains, wall outlets, main distribution levels connected closer to the supply system but less than the primary supply system (CAT IV)

Safety Information

In this manual, a **Warning** identifies conditions and actions that pose hazard(s) to the user, a **Caution** identifies conditions and actions that may damage the MegOhmMeter or the test instruments.

⚠ ⚠ Warning

Before and after testing, confirm that the MegOhmMeter does not indicate the presence of a hazardous voltage. If the MegOhmMeter beeps continuously and a hazardous voltage is shown on the display, disconnect test leads and remove power from the circuit under test.

⚠ ⚠ Warning: Read Before Using the MegOhmMeter

To avoid possible electric shock or personal injury:

- Use the MegOhmMeter only as specified in this manual or the protection provided by the MegOhmMeter might be impaired.
- Do not disconnect the test leads before a test has been completed and the test voltage at the terminals has returned to zero. This ensures that any charged capacitance is fully discharged.
- Ensure there is no power to the circuit under test and that all circuit capacitances are fully discharged prior to testing with this instrument.
- Avoid working alone or around explosive gas, vapor or dust.
- Do not use the MegOhmMeter in a wet environment.
- Inspect the test leads for damaged insulation or exposed metal. Check test lead continuity. Replace damaged leads.
- Do not use the MegOhmMeter if it looks damaged.
- Take care when working above 30 V ac rms, 42 V ac peak and 60 V dc. Such voltages pose a shock hazard.
- When using the probes, keep fingers behind the finger guards.
- Measurements can be adversely affected by impedances of additional operating circuits connected in parallel.
- Place test leads in proper input terminals.
- Do not use the MegOhmMeter with any parts or cover removed.
- Disconnect the test leads from the circuit under test and from the MegOhmMeter before changing the fuse.
- Use only Fluke approved replacement fuses, parts, and accessories as specified in this manual.
- Do not use the MegOhmMeter if the safety shutter is impaired in any way. The safety shutter prevents access to the test terminals and charger terminals at the same time.
- There are no user replaceable parts inside the instrument.
- Use the guard terminal only as specified in the Users Manual. Do not allow other accessories or foreign objects to come into contact with the guard terminal as safety may be compromised.

Required Equipment

Equipment required to perform the procedures in this manual is listed in Table 2. If the recommended models are not available, equipment with equivalent specifications may be substituted.

⚠⚠ Warning

Repair or servicing should be performed only by qualified personnel.

⚠ Caution

Do not attempt to use the 5500A, 5520A, or other standard calibrator for insulation and continuity resistance tests. Calibrator damage will result.

Table 2. Required Equipment

Equipment	Minimum Required Characteristics	Recommended Model
HV Probe	6 kV, $\pm 1\%$ (1000:1 Divider)	Fluke 80k-6
Digital Multimeter	500 mVdc to 1V: $\pm 0.02\%$	Agilent 3458A
¹Load with Guard Terminal	Resistances 200 k Ω , $\pm 1.25\%$, 500 V 500 k Ω , $\pm 1.25\%$, 500 V 1 M Ω , $\pm 1.25\%$, 1 kV 2.5 M Ω , $\pm 1.25\%$, 2.5 kV 5 M Ω , $\pm 1.25\%$, 5 kV 1 G Ω , $\pm 1.25\%$, 5 kV 100 G Ω , $\pm 5\%$, 500 V 200 G Ω , $\pm 5\%$, 1 kV 500 G Ω , $\pm 5\%$, 2.5 kV 1 T Ω , $\pm 5\%$, 5 kV	Combinations of: Welwyn F Series, Welwyn MFP2 Series And Vishay HTS-523
²Capacitors w/ Bleeder Resistors	0.1 μ F, $\pm 5\%$, 500 V, Polypropylene 1 μ F, $\pm 5\%$, 2.5 kV, Polypropylene	
Calibrator	DC current: 2 mA Accuracy: $\pm 1.25\%$ DC Voltage: 0 - 550 V Accuracy: $\pm 0.005\%$ AC Voltage: 0 - 240 V, 60 Hz Accuracy: $\pm 1.25\%$	Fluke 5520A
AC Hi-pot Tester	3 kV @ 20 mA	Instek GPT-705
IR Transceiver and Cable		Fluke IR 120
Lab Supply	12 Vdc with 2 Amp capability	
Personal computer	IBM compatible, with Microsoft Windows	
<p>1. Resistors must have a voltage coefficient consistent with the test voltage used. 2. Can use (3) each, 0.033 μF, 2 kV capacitors in series and (8) each, 8 μF, 450 V capacitors in series to obtain required values. The 0.033 μF capacitors should have a 33 MΩ bleeder resistor across each capacitor. The 8 μF capacitors should have a 15 MΩ bleeder resistor across each capacitor.</p>		

Performance Test Procedure

⚠ ⚠ Warning

To avoid electric shock hazard, do not contact the output terminals while performing the following procedures. There are potentially dangerous voltages at the MegOhmMeter output terminals when the MegOhmMeter is in the MΩ TEST function.

The following performance tests ensure that the MegOhmMeter, referred to as “the UUT” (Unit Under Test) in this section of the manual, is in proper operating condition and meets the published accuracy specifications. If the UUT fails any of the performance test steps, repair is needed. Refer to Contacting Fluke for service information.

Button Test

Operate each of the front panel buttons in turn. All buttons should have a similar feel and tactile click when operated.

Display Test

Turn the UUT on several times while observing the display during power up. Compare the display with the example in Figure 1. Check all segments for clarity and contrast.

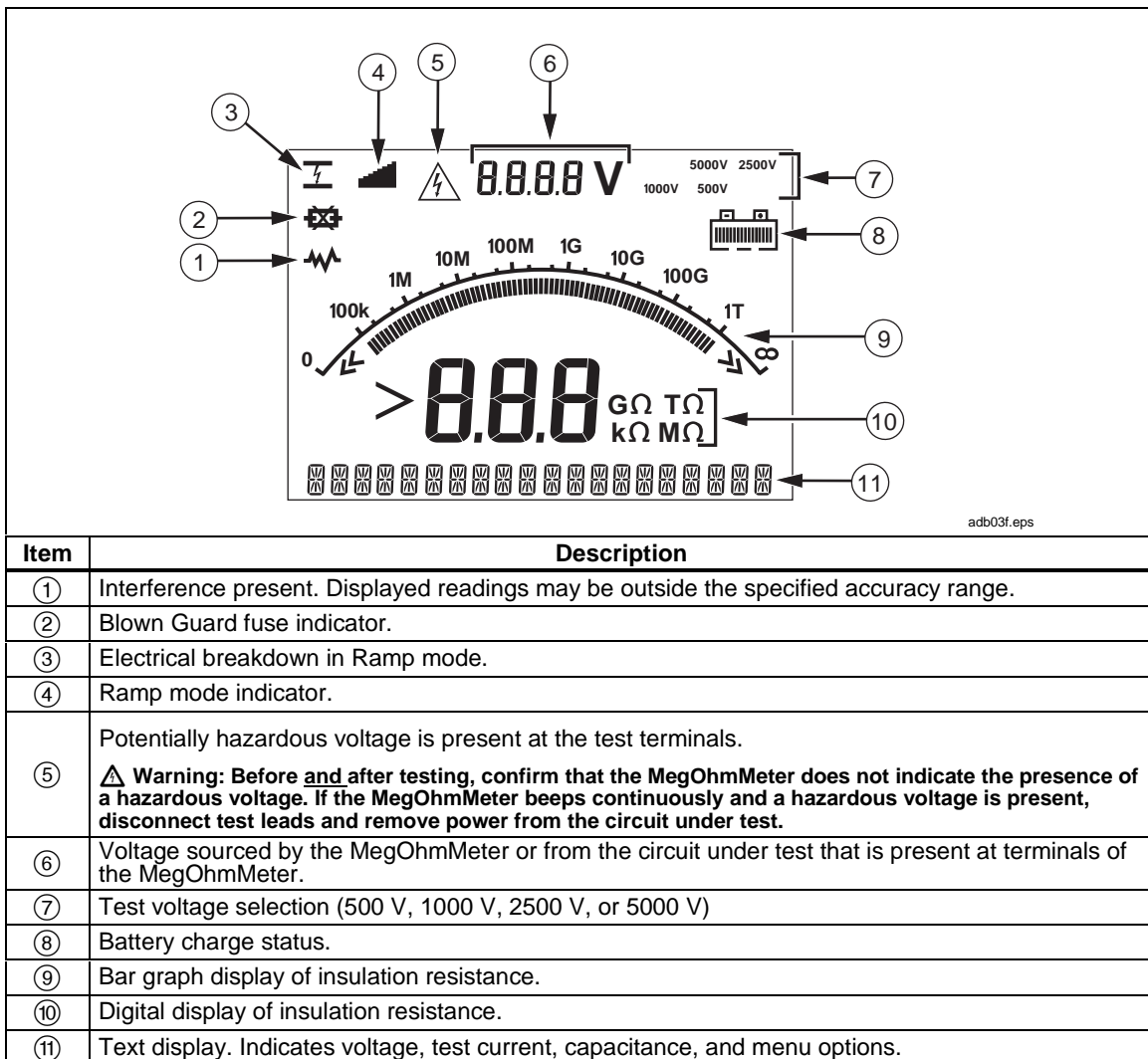

Figure 1. Display

Flash Test

Connect an AC hi-pot tester between the black LV charger socket and the neutral/live wire of the UUT mains inlet lead. Perform a flash test at 3 kV ac. No breakdown or flashover shall occur.

Charging Test

1. With the MegOhmMeter switched off, connect a mains supply to the AC supply receptacle and check that the UUT display shows **Charging**.
2. Disconnect the mains supply and check that the UUT turns off.
3. Connect a 12 Vdc, 2 A lab supply to the LV charger lead and check that the UUT display shows **Charging**.
4. Disconnect the supply and check that the UUT turns off.

Insulation Accuracy Test

Using the various resistances shown in Table 3, perform the UUT insulation accuracy test. Push  to start or discontinue a test.

Notes

- For best results, allow for settling of up to 60 seconds when measuring high-value resistances (100 GΩ and above) and take care to avoid stray currents. Perform the test on a conductive work surface that is connected to the UUT's GUARD terminal and the load GUARD terminal.
- Motion/body capacitance can affect the stability of the reading at higher resistances. When taking the measurements above 1 GΩ, remain as motionless as possible.

The capacitance reading is obtained by pressing  after a test has started.

Table 3. Insulation Accuracy Test

Step	Voltage Range	Resistance	UUT Display Limits	
			Minimum	Maximum
1	500 V	100 GΩ	80 GΩ	120 GΩ
2	500 V	1 GΩ	0.95 GΩ	1.05 GΩ
3	500 V	500 kΩ	475 kΩ	525 kΩ
4	500 V	200 kΩ	190 kΩ	210 kΩ
5	1kV	200 GΩ	160 GΩ	240 GΩ
6	1kV	1 GΩ	0.95 GΩ	1.05 GΩ
7	1kV	1 MΩ	0.95 MΩ	1.05 MΩ
8	2.5 kV	500 GΩ	400 GΩ	600 GΩ
9	2.5 kV	1 GΩ	0.95 GΩ	1.05 GΩ
10	2.5 kV	2.5 MΩ	2.37 MΩ	2.63 MΩ
11	5 kV	1 TΩ	0.80 TΩ	1.20 TΩ
12	5 kV	1 GΩ	0.95 GΩ	1.05 GΩ
13	5 kV	5 MΩ	4.75 MΩ	5.25 MΩ
14	500 V	0.1 uF	0.05 uF	0.15 uF
15	2.5 kV	1 uF	0.82 uF	1.18 uF

Output Voltage Test

In Table 4 the UUT output voltage is checked with various loads applied. In this test a voltmeter with a high-voltage probe must be connected to the load resistor to measure the UUT output voltage.

Table 4. Output Voltage Test

Step	1550 Voltage Range	Load Resistor	Reading Limits	
			Minimum	Maximum
1	500 V	500 k Ω	500 V	550 V
2	500 V	No Load	500 V	550 V
3	1 kV	1 M Ω	1000 V	1100 V
4	1 kV	No Load	1000 V	1100 V
5	2.5 kV	2.5 M Ω	2500 V	2750 V
6	2.5 kV	No Load	2500 V	2750 V
7	5 kV	5 M Ω	5000 V	5500 V
8	5 kV	No Load	5000 V	5500 V

Short Circuit Current Test

To verify the UUT short circuit current, use the following procedure:



1. Connect an ammeter between the UUT + and - terminals.
2. Turn the UUT on and allow to startup.
3. Wait for **Test Voltage** to appear on the display and set the test voltage to 5000 V by pushing .
4. Push  and note that the ammeter reading is within the reading limits referred to in Table 5.
5. Push  to discontinue the test.

Table 5. Short Circuit Current Test

Step	1550 Voltage Range	Reading Limits	
		Minimum	Maximum
1	5000 V	1.20 mA	1.80 mA

Voltage Measurement Accuracy

To verify voltage measurement accuracy of the Live Circuit Warning function, apply the voltages listed in Table 6 to the + and - terminals of the UUT. Verify that:

- The UUT reading is within the display limits of Table 6.
- The UUT is beeping at a 1-second interval.
- ⚠ is flashing on the display.

Table 6. Voltage Measurement Test

Step	Voltage Source Output	UUT Display	UUT Tone	UUT Display Limits	
				Minimum	Maximum
1	-34 Vdc	Flashing Hazard	Beeps	30 V	38 V
2	240 Vac, 60 Hz	Flashing Hazard	Beeps	226 V	254 V

Calibration Procedure

The MegOhmMeter should be calibrated yearly to ensure compliance with its specifications.

Interface Connection

Calibration is performed through software using a computer and IR (infrared) adapter, refer to Figure 2.

Connect the infrared adapter with the interface cable to a COM port of the computer. Place the IR 120 Infrared Communications Adapter so that the lens is aimed at the UUT IR Port. The IR 120 may be placed up to 1 meter from the UUT.

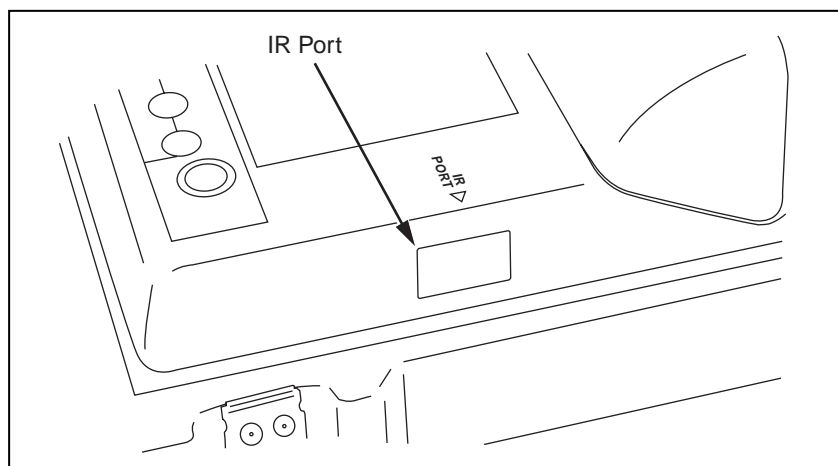

Figure 2. IR Port on the MegOhmMeter

adb04f.eps

Instrument Setup

Turn the MegOhmMeter on and wait for **Test Voltage** to appear on the display. From the computer terminal, activate the HyperTerminal program from the Windows Start menu. Set the communications settings to:

Bits per second (Baud) = 9600

Data bits = 8

Parity = None



Stop bits = 1

Flow control = None

The calibration menu can now be displayed by typing “homer” on the terminal. The following menu options will be displayed:

```
----> Calibrate HV Output and Measurement
      Calibrate Current Measurement
      Calibrate Charge Measurement
      Calibrate Battery Status
      Install Default Opvars
      Dump Opvars
      Dump Raw ADC Readings
```

⚠ Caution

The UUT  and  keys or the \uparrow and \downarrow keys of the terminal, are used for moving the cursor to the desired menu option. **Do not push the terminal ENTER key for any of these options at this time.**

⚠⚠ Warning

While performing the following procedures, the equipment and user can be exposed to dangerous high voltage when the UUT is in the “Calibrate HV Output and Measurement” mode.

Normalizing the HV Probe and Digital Multimeter

1. Connect the HV probe and digital multimeter to the 5520A **NORMAL** output terminals, observing polarity. Manually set the multimeter for a range that has a 10 M Ω input impedance (e.g., 100 V) and provides a maximum resolution for a 500 mV and 5000 mV input.
2. Set the 5520A output to 506 V and note the digital multimeter reading. Record this value.
3. Set the 5520A output to 1000 V and note the voltmeter reading. If the error is $> 0.025\%$ from the nominal value, calculate the error from nominal into a percentage. Multiply 5005 V by this percentage and algebraically add to 5005 V. Record this value.
4. Set the 5520A to standby and disconnect the HV probe and digital multimeter.

HV Calibration

1. Connect the HV probe and digital multimeter to the output terminals of the UUT, observing polarity.
2. Go to the main calibration menu as described in “Instrument Setup”. Using the terminal \uparrow and \downarrow key, move the cursor to “Calibrate HV Output and Measurement” option.
3. Press the **ENTER** terminal key. The UUT momentarily displays **HV OFFSET** then flashes Δ with PWM 0075, while emitting a beep at 1-second intervals.
4. Use the \uparrow and \downarrow keys on the terminal to modify the UUT output value to as close as possible to the value recorded in step 2 of “Normalizing the HV Probe and Digital Multimeter”. The nominal value for this adjustment is between 502 and 510 V.
5. Press the **ENTER** terminal key. The UUT now increases its output to nominally 5000 V.
6. Use the \uparrow and \downarrow keys on the terminal to modify the UUT output value to as close as possible to the value obtained in step 3 of “Normalizing the HV Probe and Digital Multimeter”. The nominal value for this adjustment is between 5000 V and 5010 V.
7. Press the **ENTER** terminal key. The HV generation and measurement functions are now calibrated.
8. Disconnect the HV probe and digital multimeter from the UUT.

Current Calibration

1. Go to the main calibration menu as described in Instrument Setup. Using the terminal \uparrow and \downarrow keys, move the cursor to the “Calibrate Current Measurement” option.
2. Attach a current source to the LO and GUARD terminals of the UUT, connecting the current source LO to UUT GUARD terminal.
3. Press the **ENTER** terminal key.
4. Apply 2 mAdc to the UUT.
5. Press the **ENTER** terminal key. The calibration takes a few seconds.
6. The current measurement is now calibrated. Disconnect the current source.

Charge Calibration

1. Go to the main calibration menu as described in Instrument Setup, and use the terminal \uparrow and \downarrow keys to move the cursor to the “Calibrate Charge Measurement” option.
2. Press the **ENTER** terminal key.
3. Attach a current source to the LO and GUARD terminals of the UUT, connecting the current source LO to UUT Guard.
4. Apply 2 mAdc to the UUT.
5. Press the **ENTER** terminal key. The Calibration takes about 40 Seconds. The charge/capacitance measurement function is now calibrated.
6. Put the 5520A in standby. To restore normal operation, cycle the power off and back on.

This completes the Calibration Procedure.

Additional Procedures

Note

The following additional procedures are used during factory calibration and repair but should not be performed in the field. They are included for information only.

Battery Calibration (Calibrate Battery)

Battery calibration **should not** be performed, as it requires disconnecting the battery and replacing it with a power supply. The battery calibration was performed during the measurement PCB test.

Install Default Opvars (Default Opvars)

Do not use. This option installs default values into all of the opvars (**O**perational **V**ariables for calibration stored in non-volatile memory). Full re-calibration is required after this command including battery re-calibration.

Dump Opvars (Dump Opvars)

This option causes the opvars and current settings to be displayed on the terminal. The opvars may be useful for fault finding.

Dump Raw ADC Readings (Diagnostics)

This option displays the raw readings from the three ADC channels: voltage, current, and charge. The first column displays the current range, which may also be incremented using 'S' or SCROLL. This feature can be useful to identify faults with the input circuitry.

Battery Replacement Procedure

Warning

To avoid electrical shock or personal injury, remove the test leads and any input signals before opening the case or replacing the battery or fuse. To prevent damage or injury, install ONLY batteries or fuses specified for the product.

Caution

Do not attempt to repair or service the MegOhmMeter unless qualified to do so and you have the relevant calibration, performance test, and service information.

Note

This instrument contains a lead-acid battery. Do not mix with the solid waste stream. Spent batteries should be disposed of by a qualified recycler or hazardous materials handler. Contact your authorized Fluke Service Center for disposal and recycling information.

Storing rechargeable lead-acid batteries in a low-charged state could lead to reduced life and/or damage. Fully charge the battery before storing for extended periods and check, the charge at regular intervals.

The MegOhmMeter is powered by 12 V lead acid battery, Fluke P/N 1669932. The battery can be recharged using the AC power cord or the DC charger leads that are shipped with the MegOhmMeter.

Fully charging the battery typically takes 12 hours. Avoid charging in extremes of temperature. Recharge the battery if the MegOhmMeter has been stored for extended periods.

If the battery needs to be replaced, refer to Figures 3 and use the following procedure to replace the battery.

Disassembly

⚠ Caution

Disassembly must be performed using proper ESD handling techniques. Place the unit on an anti-static mat and use a grounded wrist strap during the following procedure.

1. Disconnect the test leads from any live source and power off the MegOhmMeter. Remove the mains supply cable and LV charging leads from the instrument.
2. With the case latched, turn the unit over and place the instrument on a level surface with feet up.
3. Remove the 4 screws and feet from the Rotomould case. This frees the entire electronic chassis from the case and cover.
4. Set the unit upright, unsnap the case latches and open the cover. Remove the instrument chassis from the case and set it on the anti-static mat so that the instrument panel and LCD are face down.
5. Unscrew and remove the two chassis standoffs that protrude from the battery-mounting bracket.
6. Remove the two screws at each end of the battery bracket assembly.
7. To gain access to the battery connections, rotate the battery as shown in Figure 3.
8. Remove the positive and negative sleeved connectors from the battery. Take note of how the battery and the unit are assembled. It will be necessary for reassembly.

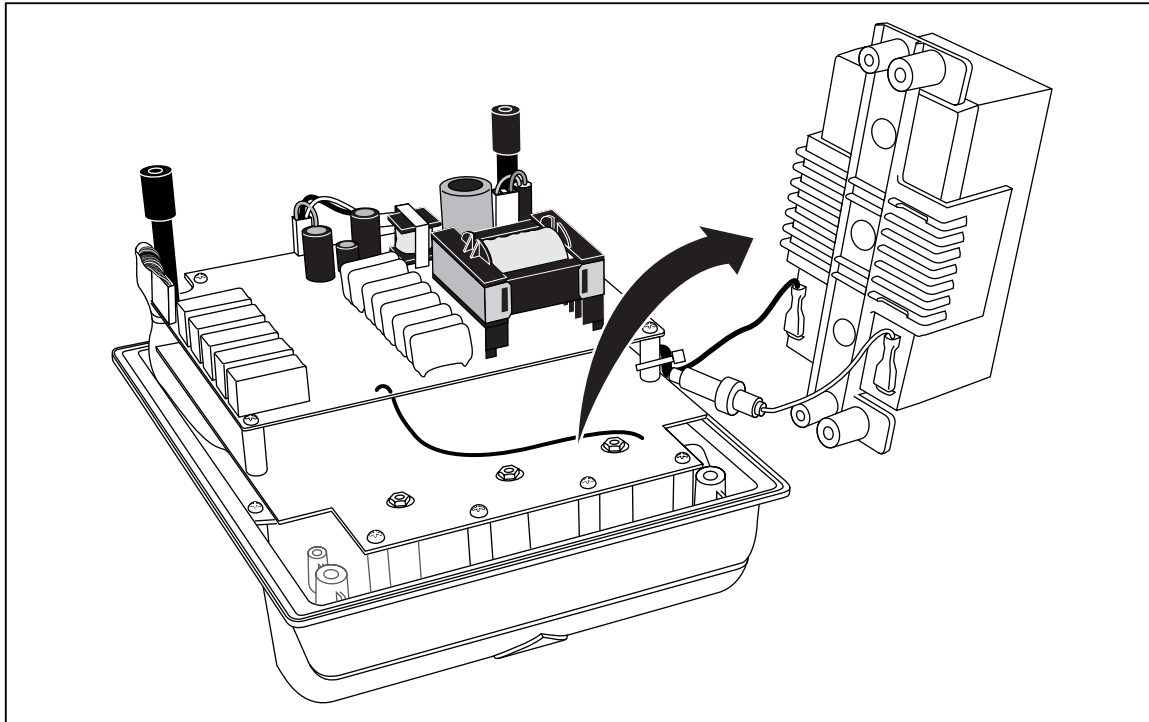

aep1.eps

Figure 3. 1550 Disassembly

Re-assembly

1. Place the new battery assembly in position, and attach sleeved connectors to the battery, observing correct polarity.
2. Reverse steps 2 through 6 of the disassembly procedure to re-assemble the MegOhmMeter.

Replacing the Guard Fuse

⚠⚠ Warning

To avoid electric shock, personal injury or damage to the MegOhmMeter:

- Replace the fuse in accordance with the following procedure, using **ONLY** the replacement fuse specified in Replacement Parts.
- Disconnect the test leads and / or any connectors.

To replace the Guard fuse (refer to Figure 4):

1. Turn off the MegOhmMeter.
2. Rotate the safety shutter toward the top of the MegOhmMeter to expose the power supply connections and Guard fuse receptacle.
3. Remove the fuse holder by using a standard-blade screwdriver to turn the fuse holder counter clockwise until it unlocks.
4. Lift out the fuse holder and remove the fuse from the fuse holder.
5. Install the new fuse and drop the fuse holder back into the MegOhmMeter.
6. Tighten and lock the fuse holder by turning it clockwise with the screwdriver.

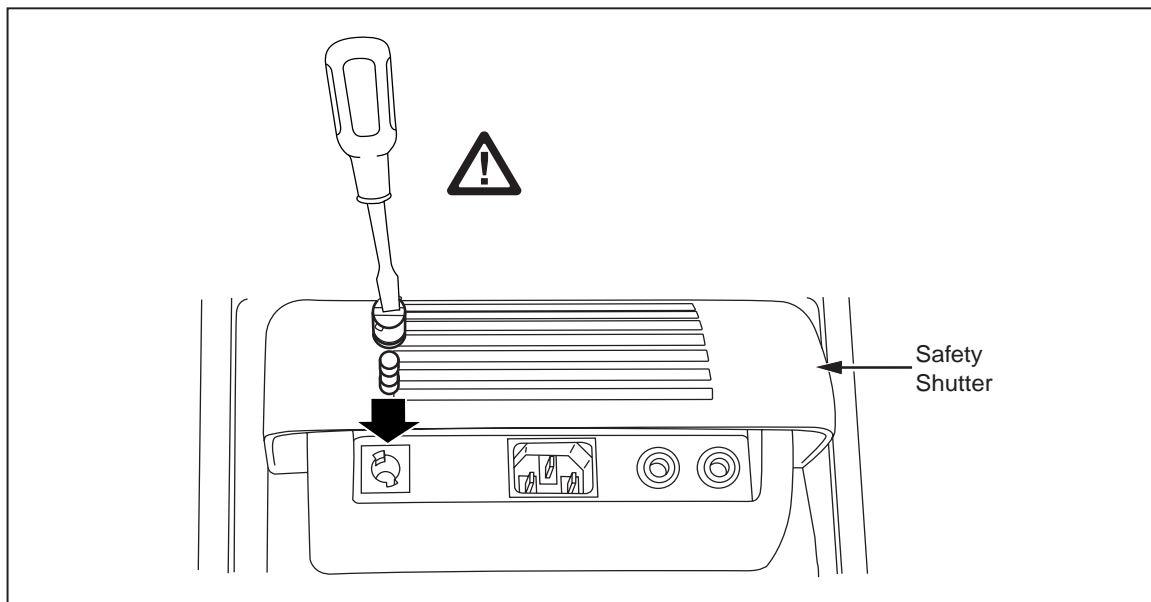

Figure 4. Replacing the Guard Fuse

adb12f.eps

Cleaning

Warning

To avoid possible electric shock or personal injury, remove excess water from the cloth before cleaning the MegOhmMeter to ensure that water does not enter any terminal.

Periodically wipe the case with a damp cloth and mild detergent. Do not use abrasives or solvents to clean the MegOhmMeter.

Replacement Parts/Accessories

Replacement parts are listed in Table 7.

Table 7. Replacement Parts

Parts	Part Number
Test Cable Red	1642584
Test Cable Black	1642591
Test Cable Green	1642600
Test Clip Red	1642617
Test Clip Black	1642621
Test Clip Green	1642639
Carry Case	1642656
 Guard Fuse, 100 mA, 250 V, Type F (Fast) to IEC127	1642663
IR20, IRDA Adapter and Cable	1642688
Rotomould Base & Cover	1642859
Living Hinge for Rotomould Case	1670893
Battery and Housing Assembly	1669932
Latch for Rotomould Case	1670887
AC Power Cord (S. Africa)	1552363
AC Power Cord (Australia)	658641
AC Power Cord (UK)	769455
AC Power Cord (Continental Europe)	789422
AC Power Cord (North America)	284174
Soft Carrying Case	1642658
DC Charger Cable	1642695
 Charger Fuse, 5 A, 1.5-in X 0.25-inch, Quick Blow (Fast) Fuse	1643479
CD ROM (Includes QuickLink HVT Communication Software and Users Manuals [English, French, German, Spanish])	1989912

Specifications

General Specifications

Display	75 mm x 105 mm	
Power	12 V lead-acid rechargeable battery. Yuasa NP2.8-12	
Charger Input (AC)	85 V to 250 V ac 50/60 Hz 50 VA	
Charger Input (DC)	10 to 15 V dc, 30 VA	
△ Guard Fuse	HBC 100 mA, 250 V, Type F (Fast) to IEC127	
△ Charger Fuse	5 A, 1.5-in x 0.25-in quick blow (F) fuse	
Dimensions (H x W x L)	170 mm x 242 mm x 330 mm (6.7 in. x 9.5 in. x 13.0 in.)	
Weight	4 Kg (8.8 lbs.)	
Temperature (operating)	-20 °C to 40 °C (-4 °F to 104 °F)	
Temperature (storage)	-20 °C to 65 °C (-4 °F to 149 °F)	
Humidity	80 % to 31 °C decreasing linearly to 50 % at 40 °C	
Altitude	2000 m	
Enclosure Sealing	IP40	
Input Overload Protection	600 V to earth ground	
Electromagnetic Compatibility	EN 61326	
Certifications	UL, CE, CSA, TÜV	
Safety Compliance	EN 61010, EN 61557 Parts 1 and 2 IEC 61010-1, CAT III V 600, Pollution Degree 2	
Typical Battery Charge Capability Note At higher temperatures, the battery requires charging more frequently.	Test Voltages	Number of Tests
	500 V	3600
	1 kV	3200
	2.5 kV	2500
	5 kV	1500

Electrical Specifications

Accuracy is specified for 1 year after calibration at operating temperatures of 0 °C to 35 °C. For operating temperatures between -20 °C to 0 °C and 35 °C to 40 °C, these tolerances double.

Insulation		
Test Voltage (DC)	Insulation Resistance Range	Accuracy (+/- reading)
500 V	< 200 kΩ 200 kΩ to 10 GΩ 10 GΩ to 100 GΩ > 100 GΩ	unspecified 5% 20% unspecified
1000 V	< 200 kΩ 200 kΩ to 20 GΩ 20 GΩ to 200 GΩ > 200 GΩ	unspecified 5% 20% unspecified
2500 V	< 200 kΩ 200 kΩ to 50 GΩ 50 GΩ to 500 GΩ > 500 GΩ	unspecified 5% 20% unspecified
5000 V	<200 kΩ 200 kΩ to 100 GΩ 100 GΩ to 1 TΩ >1 TΩ	unspecified 5% 20% unspecified
Bar Graph Range:		0 to 1 TΩ
Insulation Test Voltage Accuracy:		-0 %, +10 % at 1 mA load current
Induced ac Mains Current Rejection:		2 mA maximum
Charging Rate for Capacitive Load:		5 seconds per μF

Leakage Current Measurement	
Range	Accuracy
1 nA to 2 mA	+/- (5 % + 2 nA)
Capacitive Measurement	
Range	Accuracy
0.01 μF to 15.00 μF	+/- (15 % of reading + 0.03 μF)
Timer	
Range	Resolution
0 to 99 minutes	Setting: 1 minute Indication: 1 second
Live Circuit Warning	
Warning range: 30 V to 600 V ac/dc, 50/60 Hz Voltage accuracy: +/- (5 % + 2 V)	

