

OWNER'S MANUAL

Electronic Balometer[®] with APM 150 Meter



ALNOR[®]
A TSI[®] Company

TABLE OF CONTENTS

General Description	2
Safety	2
Getting Started	3
Installing Batteries	3
Preparing the Instrument	3
Hood Attachment	3
Alternate Hood Installation	5
Standards	6
Flow Resistance	6
Temperature	7
Atmospheric Pressure	7
Attaching the Optional Probes (175, 275, 220B)	7
Clearing the Memory	7
The Display	8
Detailed Operation	8
A. APM 150 Keypad and Menus	10
The APM 150 Keypad	10
Primary Key Functions	10
Secondary Key Functions	11
Menu Selections	11
Menu Items	11
B. Using the APM 150	12
Basic Functions	12
To Change Units	12
To Hold a Reading (For storage or printing)	12
Measurement Modes	12
Volume Selection	12
Data Storage	13
Troubleshooting	14
Maintenance	15

GENERAL DESCRIPTION

The Alnor Electronic Balometer system with the APM 150 meter is designed to measure supply or exhaust air flow from diffusers or grills in HVAC systems. The assembly consists of a meter, nylon hood, handles, and a base. The meter has a digital readout of volume flow and temperature when used with a Balometer base. The range of measurement spans from 50 to 2000 CFM (85 to 3400 m³/h or 24 to 945 l/s) and 32°F to 122°F (0°C to 50°C). The meter sums and averages air flow up to 100 points.

Functions are selected through a 7-key pad on the APM 150. In addition, the user can choose from among many menu-driven items for added measuring flexibility. Options such as units of measurement and time-constant settings can also be selected.

The APM 150 displays measurement results on a liquid-crystal display (LCD), with additional display segments for memory locations and units of measure.

The instrument's memory can hold 100 readings of velocity, volume, or temperature. For convenience, memory can be organized into sections called "pages." All data is saved in battery-backed memory.

Readings can be printed during operation by an optional printer, or can be saved for subsequent downloading. The RS232-C serial connection attaches the APM 150 to a printer or personal computer.

The adjustable tilt mechanism allows the user to comfortably read the meter from a wide range of angles.

The APM 150 meter can be disconnected and removed from the base and used with a variety of Alnor probes.

Three replaceable AA size batteries power the instrument. An automatic shut-off can be enabled by the user to increase battery life.

SAFETY

DANGER

- When using the instrument to check air flow in an elevated workplace, make certain that you can safely raise and hold the instrument while making measurements. This is especially important when you are working on a ladder.
- Avoid catching attachments in moving machinery.

- Use the instrument only for measurements using air.
- Avoid any corrosive or other dangerous or explosive gas mixtures.

NOTICE

Please dispose of used batteries in a responsible manner.

GETTING STARTED

Installing Batteries

The APM 150 uses three (3) AA size non-rechargeable batteries. The unit is shipped with batteries not installed. You will find the batteries in the instrument package.



Figure 1—Front view

To install the batteries:

- Loosen the battery cover screw on the front of the instrument.
- Slide the cover left and lift it out. (Fig. 1)
- Install the batteries over the pull strap, taking care to observe each battery's polarity.
- Replace the cover and tighten the screw.

Note: When the batteries become low, the LCD will show [LO B A E E] above the reading. From that point, you will have about one hour of normal use left. If [B A E E] comes on continuously and replaces the reading, the battery voltage is too low for accurate measurements and the meter will turn itself off.

Always keep a replacement set of new batteries available.

Preparing the Instrument

The meter is shipped with its auto shut-off feature enabled. This setting will automatically turn the unit off after a twenty minute period of key-pad inactivity. To disable this feature, follow the instructions in the menu selections (see page 11).

Before removing any parts from the carrying case, the arrangement of the various items should be noted so that repacking can be done easily. See Figures 2 and 3.

If your instrument is equipped with more than one hood, the frame channels needed to support other sizes are stored under the base of the Electronic Balometer inside the accessory case. The extra hoods are stored around the Electronic Balometer base.

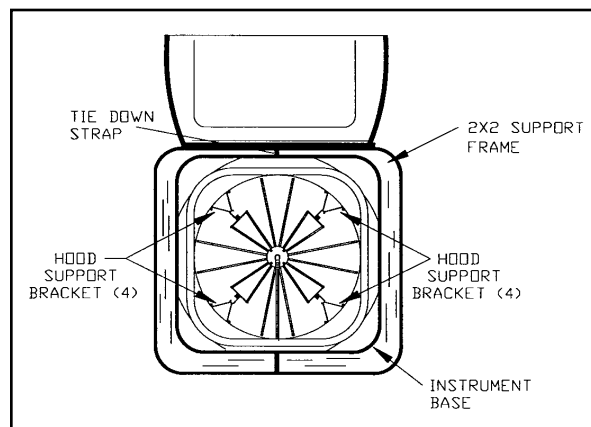

Figure 2—Top view of carry case

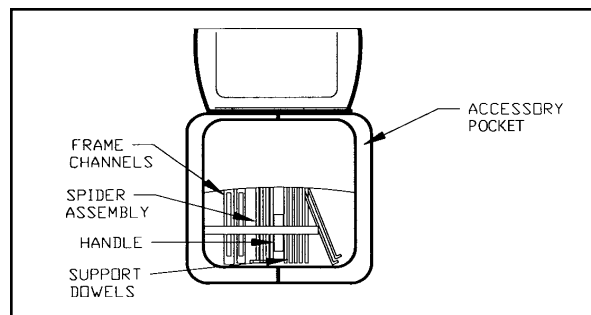

Figure 3—Unpacking accessory case

Hood Attachment

- Step 1: Remove the tie down straps at the two locations shown in Figure 2.
- Step 2: Holding the 2 ft x 2 ft (600 x 600 mm) hood frame, gently lift the entire instrument assembly and set it to the side of the carrying case.

Step 3: The accessory case, located underneath the Electronic Balometer, is now exposed. Lift the pull tab and pull back to expose the accessory items. See Figure 3. Remove the spider assembly, support dowels and handle from the case. Figure 3 also shows the packing position of the accessory frame channel pieces. If installing a different hood size, remove these pieces at this time.

Note: *The APM 150 Electronic Balometer system comes from the factory with a 2 ft. x 2 ft. (600 x 600 mm) nylon hood installed on the base. The following steps will complete the preparation of the Electronic Balometer for use with this hood. If a different hood size is required for first time use, go to the section titled ALTERNATE HOOD INSTALLATION.*

Step 4: Unfold the spider assembly mechanism. See Figure 4. This mechanism will now be inserted into the four hood support brackets located in each corner of the base. Grasp one of the wire formed legs in each hand. Insert each of the legs into the center hole of the hood support brackets. Grasp the remaining two legs and insert them into the center holes of the remaining hood support brackets. If it is later found that the hood is not held as tautly as required, the spider assembly can be moved upward to compensate.

Step 5: Place the four support dowels on the spider assembly mechanism as shown in Figure 4. The aluminum tips on the dowels should be facing up. If a 2 x 4 or 3 x 3 (600 x 1200 or 900 x 900 mm) hood set is to be used, the set of 8 inch (200 mm) long dowels must be added to either end of the long dowels.

Step 6: Raise the hood up until it is taut. Insert a support dowel into one of the corners of the frame nearest to you. Take care to ensure that the support dowel is not pressing against the hood material. Insert a second support dowel into the remaining corner close to you. Lift up the far side of the hood. Pressing firmly

down on the support dowel, move the dowel into the third corner. Finally, pressing down on the last dowel, insert it into the remaining corner.

Step 7: If desired, install the detachable handle next, as shown in Figure 4.

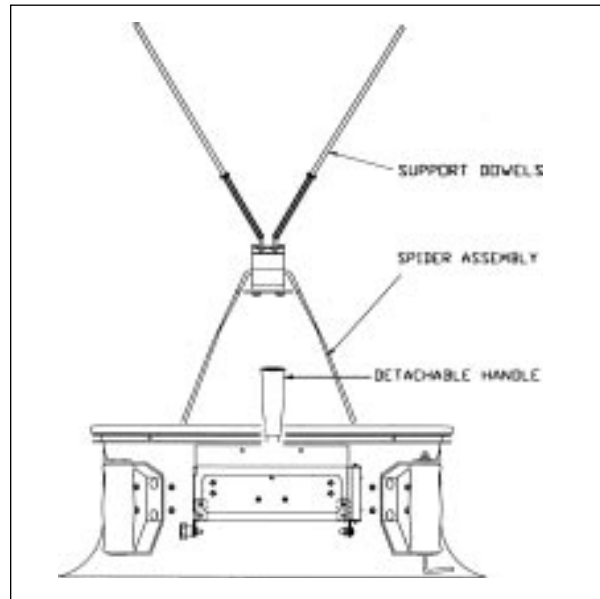

Figure 4—Instrument assembly

CAUTION Make a habit of checking the tightness of this handle each time before use. Be sure it does not loosen while the instrument is being used or while it is being carried from place to place.

Step 8: Verify that the sensor connector is attached to the meter. If it is not attached, line up the key as shown in Figure 5 and firmly press the connector into the meter. Tighten the connector by rotating the knurled ring.

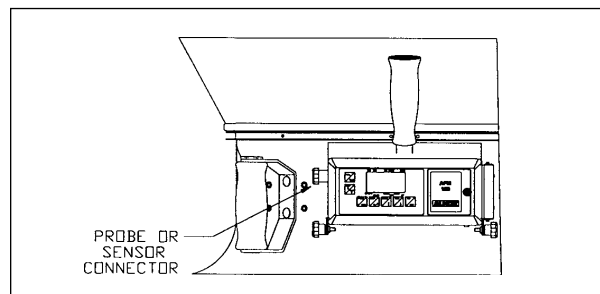

Figure 5—Sensor connector attachment

Step 9: Verify that the handle hold button connector is plugged into the sensor module as shown in Figure 6.

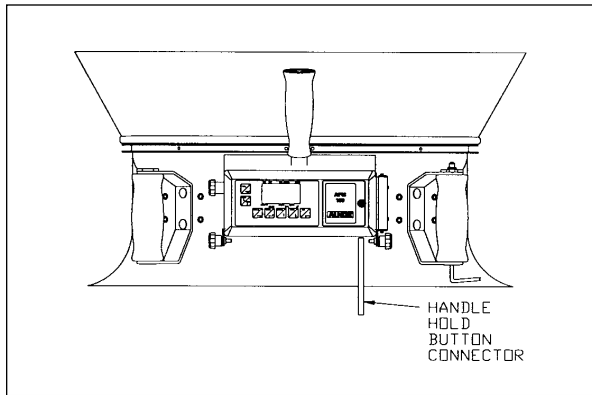

Figure 6—Hold button connector attachment

Step 10: The meter may be tilted for convenient viewing by loosening the tilt release knobs located under the meter. Adjust the meter to the desired angle and tighten the knobs.

See Figure 7 for various ways to hold the Electronic Balometer.

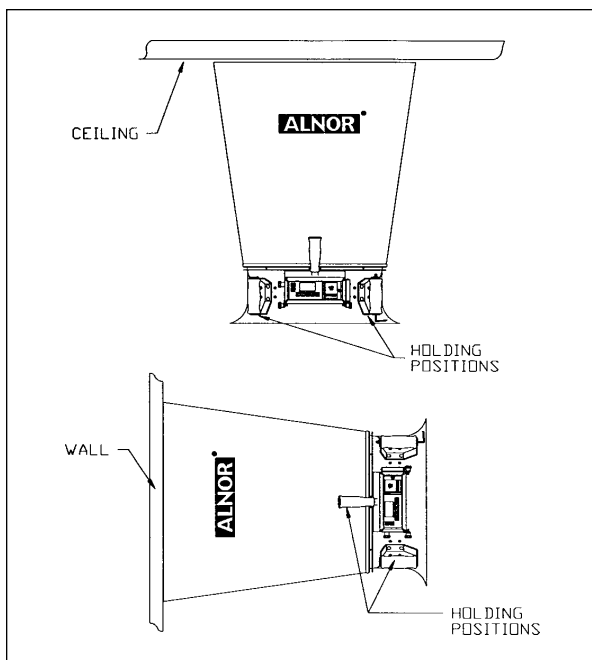

Figure 7—Holding Balometer for measurement

To begin using the APM 150 Electronic Balometer system, proceed to Keypad and Menu selections.

Tip: Before using the Electronic Balometer, allow the unit to warm up for 15 minutes to achieve best possible accuracy (Deactivate Auto Shut-off.) The meter may be turned on before the hood is set up to minimize waiting time before taking measurements.

Alternate Hood Installation

Refer to Figures 8 through 11 to determine the frame channels needed to assemble any of the standard sized frames. Select the pieces required for the frame size desired and assemble with the aid of the appropriate figure. Each channel is labeled with its number for easy identification. Several sections (numbers 1, 3, and 4) consist of a straight channel portion (each a different length) and a corner piece. This corner piece has an eyelet and slot arrangement which mates with a similar eyelet and slot at the end of the straight portion of the channel pieces (see Figure 12). These pieces can be slid together and are self locking by means of a retention spring. The arrangement forms a rugged frame which is additionally strengthened when the hood is attached.

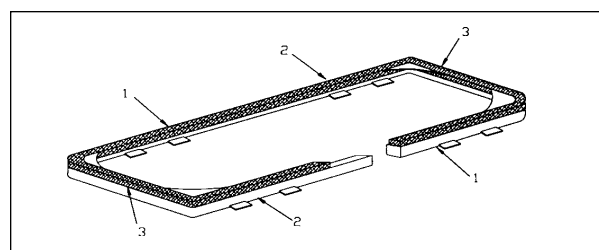

Figure 8—1' x 4' Frame (305 x 1220 mm)

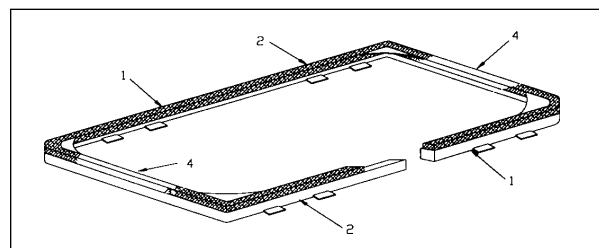

Figure 9—2' x 4' Frame (610 x 1220 mm)

The number 1 and 5 channels also have a wing nut at the straight end which will mate with an angle and studs on the ends of numbers 2, 5 and 6 to form the longer frame sides (see Figure 13).

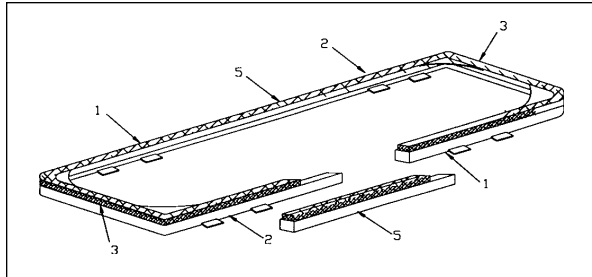

Figure 10—1' x 5' Frame (305 mm x 1525 mm)

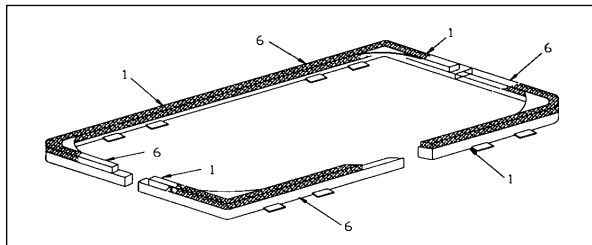

Figure 11—3' x 3' Frame (915 mm x 915 mm)

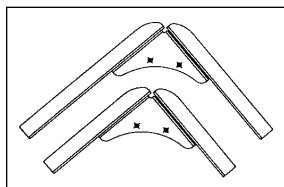

Figure 12—Frame corner assembly

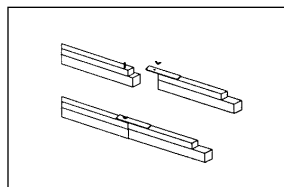

Figure 13—Frame side assembly

Each hood is constructed in a trapezoidal shape, sewn together so that one open end forms a square attachment to the base, and the other forms a square or rectangle large enough to fit its matching frame assembly. Around each end of the hood, an elastic “shock” cord has been sewn into the hood. This cord is of a size such that it can be pushed into the open side of the U-shaped channels of the frame and around the top of the base.

In general, attach a hood to the frame first, and then to the base unit. By stretching around the corners the cord is slightly reduced in diameter and is easier to press into the channel.

Note: *The hood corners should always be aligned with the corners of the base, near the hood support brackets. The base has rivets located in the corners which can be used as a guide for aligning the hood corners.*

Standards

All Balometers or hoods are calibrated to some standard. Different manufacturers or calibration facilities may use standards or methods that are different from those used at Alnor Instrument Company. Alnor uses laminar flow elements as the standard to calibrate Balometers. These are devices that are made up of a very fine honeycomb mesh. The pressure drop across a laminar flow element is approximately linear with the flow going through the element. Alnor Balometers are calibrated using a standard two by two foot square diffuser. Other manufacturers may use orifice plates or nozzles and may not use a diffuser.

When using proportional balancing techniques, these differences will not be important. However, when comparing Balometers against other hoods, or when comparing Balometers calibrated at Alnor with other calibration facilities, these differences may be important. It is not unusual to see air flow calibration differences on the order of 5% because of different standards.

Flow Resistance

All capture hoods cause flow resistance on the air handling system. Just as different diffuser styles have their own characteristic flow resistance, so do capture hoods. This added resistance reduces the true amount of air exiting the diffuser. *In the majority of cases, this error is less than or equal to the accuracy of the instrument.* Proportional balancing techniques will also assist in making these effects negligible.

To determine if the flow resistance effects are important, perform duct traverses to determine the volume rate exiting a diffuser both with and without the capture hood in place. The difference

between the volume rate with and without the capture hood in place is the flow resistance effect for that diffuser.

To determine a flow resistance correction factor for use with similar diffusers and duct configurations, use the volume rates as determined from the duct traverses both with and without the hood as follows.

$$V_{\text{hood}} = \text{Flow rate with the hood in place}$$

$$V_{\text{no hood}} = \text{Flow rate without the hood in place}$$

$$CF = V_{\text{no hood}} / V_{\text{hood}}$$

$$V_{\text{measured}} = \text{Volume rate as displayed by the capture hood}$$

$$V_{\text{corrected}} = \text{Volume rate corrected for the flow resistance of the capture hood}$$

$$V_{\text{corrected}} = CF \times V_{\text{measured}}$$

Temperature

The temperature readout on the APM 150 meter indicates general trends in the air temperature coming from a diffuser. The Electronic Balometer has a temperature sensor located inside an aluminum housing behind the meter. Because of the mass of the housing, the Electronic Balometer will show a lag in temperature reading from actual if the air temperature is changing. The time response of the temperature channel depends on the amount of flow passing through the Balometer. For flows under 200 CFM (100 l/s, 340 m³/h), the temperature time response is in the order of minutes. For fast measurements of air flow temperature, the Alnor 175 or 275 probe is recommended. To compare the temperature reading of the Electronic Balometer to a standard, the air flow temperature must remain constant to within 0.25 degrees C.

Atmospheric Pressure

Above 500 CFM (250 l/s, 850m³/h), large changes in atmospheric pressure can affect readings from the Balometer. The correct value is inversely proportional to the atmospheric pressure. A change in atmospheric pressure of -3% will require the display to be multiplied by +3%. See Appendix E for additional information.

Note: When using the Balometer, make sure that a complete seal is made around the diffuser. Any leaks will cause measurable errors.

Attaching the Optional Probes (175, 275 and 220B)

Refer to page 9 on removing the meter from the base.

To attach the probe for measuring air velocity:

- Make sure the meter is off before attaching or detaching a probe.
- Remove the protective cap from the probe and save for re-storing the probe later.
- Attach the 12-pin connector on the probe to the probe port on the meter.
- Turn the connector clockwise to tighten.

Depending on the connected sensing device, you will have a choice of available units.

Sensing Device	Available Units
Balometer Hood	l/s, m ³ /h, cfm, °F, °C
Thermo-anemometer Probe	l/s, m ³ /h, cfm, kmh, m/s, mph, fps, fpm, °F, °C
220B Relative Humidity Probe	RH, °F, °C

Clearing the Memory

If this is the first time you are using the APM 150 meter, clear the memory before using the instrument.

Clearing the memory is done with the following steps:

- Push **CLR** until [E 1 r] appears.
- Push ↑ until [H E 5] appears.
- Push ↓ to clear memory.

The meter starts in **RUN** mode. It will display measurement values associated with the unit last used. If the value is **OVERRANGE** the display will show [o r]; similarly if the instrument is measuring an **UNDERRANGE** value the display will show [0].

THE DISPLAY

The APM 150 incorporates a custom liquid crystal display (LCD) to show measured values, units of measurement, page and line numbers of last data entered, and an indicator showing if the correction factor is equal to 1. As a result, measurements exceeding 9,999 of a given unit of measure will be displayed in a scientific notation format of XXEY. The actual reading will be rounded to the nearest thousand, XX. The Y

indicates the number of zeros after XX. For example, 12,751 is displayed as [12.751].

The APM 150 is measuring and averaging the *actual* value of the reading, not the rounded scientific notation value. No accuracy loss will be encountered. When printing the data on the 8521 MicroPrinter or downloading the data to a host PC, the scientific notation reading will be seen.

DETAILED OPERATION

With the meter turned on, assemble the hood (see page 4). The display will show:

- All segments of the display
- The latest software revision
- The type of probe attached (175, 275, 220B)
- Busy message
- An air flow measurement

Note: *If the meter displays [PEE] turn unit off and check the probe connection. If this is the first time you used the meter, clear the memory (see page 7).*

Check to see if the meter's parameters are set for your application. The meter always starts measuring in the **SUPPLY** mode. To select exhaust, press the supply/exhaust key ($\frac{E}{S}$). If the meter is in the exhaust mode, the annunciation below Ex will be on. If a correction factor is needed, press the **MENU** key until [c F] is displayed. Press ↵, then press ↑ or ↓ until the right value appears, then press ↵. [c F] will be displayed. Press **ON/OFF** to return to the **RUN** mode.

To change the units of measure, press the **UNIT** key until [U n t] appears. Press the ↑ or ↓ button until the annunciation is pointing to the correct unit. Press ↵.

To take a measurement, raise the hood assembly to the diffuser, making certain the hood frame fits around the entire diffuser and is held tightly against the ceiling or wall (see page 5). Let the display settle to a steady reading. Press the **HOLD** key (you may use the red button on the right handle or the **HOLD/AVE** button on the meter). The display will flash the measured value. If this reading is not satisfactory, press the **ON/OFF** key to return to the **RUN** mode without storing the value. If the reading is satisfactory, press the **HOLD** key again to store the value. Repeat this procedure as many times as needed.

If the data is complete and another set of measurements is needed, create a new page. To achieve this, press the **MENU** key until [P R G E] is displayed. Notice the smaller indicator to the right. This displays the current working page. Press ↵, the display will automatically increase the page number. To return to the **RUN** mode press **ON/OFF**.

To examine the stored data, press the **MEM** key. The display will show the current working page. To scroll to any of the stored pages use the ↑ or ↓ key until the desired page number appears, then press ↵. The display will now show the stored line number, the value stored and its units. To continue reviewing the data, press the ↑ key.

When all the stored data is displayed, the last display will show the average or sum of the current page. Pressing up again will return the meter to the “memory page number” display. Press \uparrow or \downarrow to view another page or **ON/OFF** to return to the **RUN** mode.

If a printer is attached when pressing the **HOLD** key for the second time, the data will be stored in memory and printed. To get a hard copy of the stored data from a printer or to download to a computer, press the **MENU** key until [P r n t] appears, press \downarrow . The printed information will look like this:

MEMORY # (# is the page number)

(line number) (the measured value) (its units)
 (line number) (the measured value) (its units)
 “ “ “

“Temperature”

minimum value maximum value
 average value number of stored entries

“Flow”

minimum value maximum value
 average (or sum) value number of stored entries

Date

Name

This will repeat for all stored pages. After all data is printed, press the **ON/OFF** key to return to the **RUN** mode.

To escape from the print routine, press and hold the **ON/OFF** key until the print stops. [P r n t] will be displayed. Press **ON/OFF** again to return to the **RUN** mode.

To examine the average value of the stored data (current page only) press and hold the **HOLD/AVE** key for approximately 3 seconds. The word **AVE** will appear, then the calculated value and its units of measurement. To return to the **RUN** mode press the **ON/OFF** key.

Note: To remove the meter, squeeze the meter release latch and lift out the meter as shown in Figure 14. Replace the meter by squeezing the release latch, inserting the left side of the meter under the “L” bracket then laying the meter flat against the sensor housing before releasing the latch. Make sure that the meter is secure before moving the Balometer.

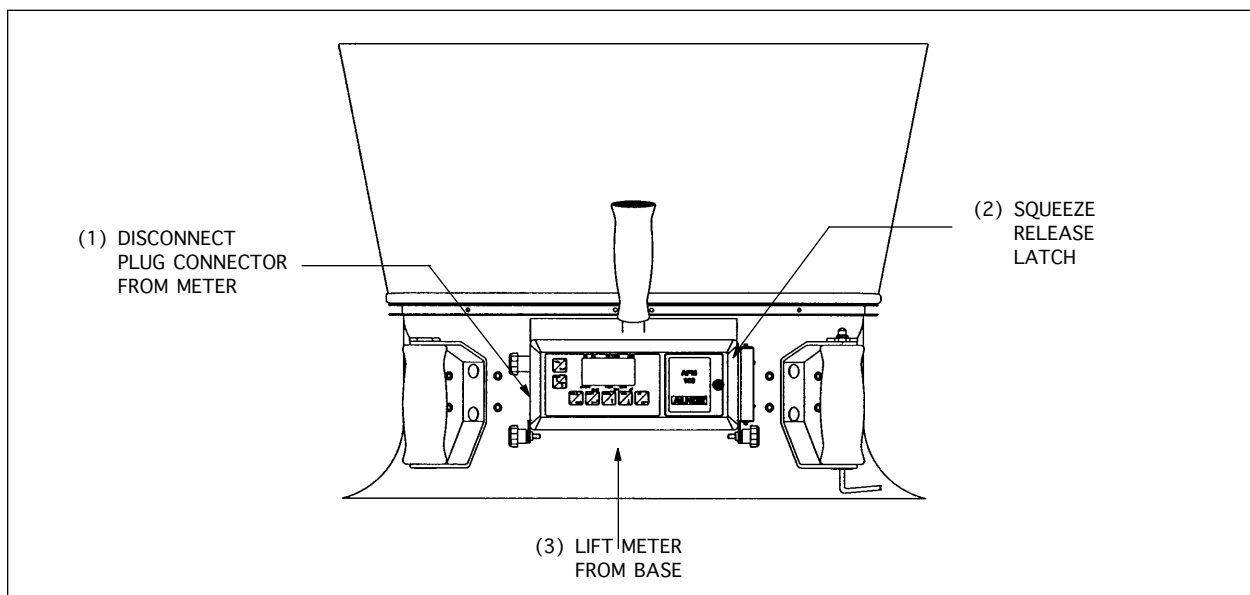

Figure 14—Removing the meter from the base

A. APM 150 KEYPAD AND MENUS

The APM 150 Keypad

Each key has two different functions. The *primary* function is shown above the diagonal line on the key's surface. The *secondary* function is shown below the diagonal line. A more detailed description of each function follows.

In the **RUN** mode, if a key is held for *less than three seconds*, the primary function is activated. When a key is held for *more than three seconds*, the secondary function is activated. The exceptions to this are the \uparrow and \downarrow keys. Because they are used to move between menu options, these keys do not function in **RUN** mode.

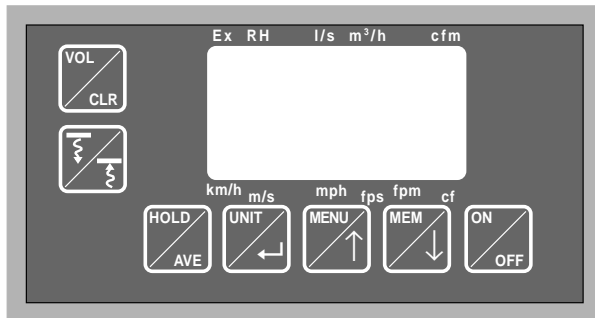

CAUTION

The cycle time of the APM 150 software may cause the meter to react slowly to a key push. The reaction time of a key push will vary with different functions (1–3 seconds). Do not push a key twice because of a slow response time. Doing so may result in accidental activation of a secondary function or duplication of a desired function.

Primary Key Functions:

ON/OFF This key is used to turn the instrument on or off when in the **RUN** mode. If the unit is in any other mode, pressing this key will exit that function and go back to the **RUN** mode without making any changes.



VOL



(Used only if a 175 or 275 probe is attached) The **VOL** key prepares the APM 150 for air volume measurements. After pressing this key, you must indicate whether you're measuring by area, whether you're measuring a round or rectangular duct, or using a selected horn. Choose one of these options by pressing the \uparrow or \downarrow key, followed by the \leftarrow key to make a selection. After you make your selection, use the \uparrow or \downarrow key to enter the dimensions, then the \leftarrow key to enter the units.

MENU



MENU allows you to select one of several options. Use the \uparrow or \downarrow keys to move through the choices. To choose a selection, push \leftarrow , or return to **RUN** mode by pushing **ON/OFF**. The **MENU** selections are as follows:

[PAGE] Changes memory page

[Print] Prints all stored data

[CF] Correction Factor

[Auto] Enables or disables auto shut-off

[HEC] Scans meter voltages

[CAL] This is only used by the factory

[Port] Enables or disables the serial port

[tc] Time constant selection

(See also Menu Selections, next page)

HOLD



Pressing this key freezes data in **RUN** mode for input to memory or output to a printer. The display flashes. Pushing **HOLD** again stores and prints your data. Pressing **ON/OFF** returns you to **RUN** mode without storing or printing.

UNIT



The **UNIT** key allows you to select a unit of measurement. The ↑ and ↓ keys move through the choices. Use the ↵ key to accept a choice, or press **ON/OFF** to return to **RUN** mode without making changes.

MEM



The **MEMORY** key is used to review stored data. When it is pressed, the display will show the current page number. The ↑ and ↓ keys will move you to any page you wish to review. To examine data, press the ↵ key.

If memory is empty, the unit automatically jumps back to **RUN** mode. Otherwise, you can return there by pressing the **ON/OFF** key.

(See also PAGES in Data Storage)



Push this key to select **SUPPLY** or **EXHAUST** air measurement modes. The meter's default is **SUPPLY**. A display annunciator ▲ will indicate **EXHAUST** (EX) when it is in that mode.

Secondary Key Functions:

↑ and ↓ These keys allow you to move or scroll through menu selections in forward (↑) or reverse (↓) order.



AVE



If held for 3 seconds, the **AVE** key lets you view the average of the current page of measurements which has been stored. Pushing **ON/OFF** returns you to **RUN** mode.

↵



This key accepts all selected choices such as values and menu items. After each entry, [b 555] appears on the display as the APM 150 stores new information.

Menu Selections

Pressing the **MENU** key activates the main menu. Use the ↑ and ↓ keys to scroll through the available selections. Once you find your desired selection, choose it by pressing ↵. Pressing **ON/OFF** exits the menu, returning you to **RUN** mode.

Menu items (to select any of the following press ↵):

PAGE Measurements stored in the instrument's memory are organized into pages. This key changes the page onto which you are saving your measurements. A total of 100 sets, or lines, of data can be stored. You may have 100 pages of one line each, one page of 100 lines each, or any combination of pages and lines not exceeding 100 readings.

Print This copies all stored data to a connected printer or computer. You can abort the printout at any time by pressing and holding the **ON/OFF** key.

cF The Correction Factor is an all-purpose multiplying factor which is applied to all measurements. cF is set to 1.000 unless it is changed in the menu. An annunciator (▼) tells the user when "cF=1." cF is usually used when air density conditions deviate from standard. See Appendix D.

Select values with the ↑ or ↓ key, then press ↵ to accept them or **ON/OFF** to reject them.

Auto This automatic shut-off option can be enabled or disabled by pushing ↑ or ↓ to select [YES] or [NO], then pushing the ↵ key to enter your selection. When enabled, the automatic shut-off will power-down the APM 150 after twenty minutes of keyboard inactivity.

HEC This diagnostic tool allows a user to view important analog voltages within the instrument. Pushing ↑ or ↓ views the eight different channels, which include the following:

- [0] — 0 V dc.
- [5] — 4.965 to 5.025 V dc.
- [7] — battery voltage (3.5 V fresh batteries)

[F] Factory use only.

Port This option allows the user to enable or disable the serial port. In the normal **RUN** mode, the port must be disabled. (Increases battery life.)

To enable port

- At menu selection [Port] press ↵.
- Press ↑ or ↓ until ON appears.
- Press ↵.

To disable port

- At menu selection [Port] press ↵.
- Press ↑ or ↓ until OFF appears.
- Press ↵.

tc allows you to select from five different speeds of display response.

- A setting of 1 is a quick response.
- A setting of 5 is a slow response.

B. USING THE APM 150

Basic Functions

To Change Units:

- Push the **UNIT** key until [UNIT] appears.
- Use the ↑ and ↓ keys to view new measurement units.
- The display annunciator ▲ will move to the selected unit. (Fig. 15)
- Push ↵ to select a new measurement unit.

For example: To change the units of measurement from cubic feet per minute (cfm) to cubic meters per hour (m³/h) while using a thermo-anemometer probe:

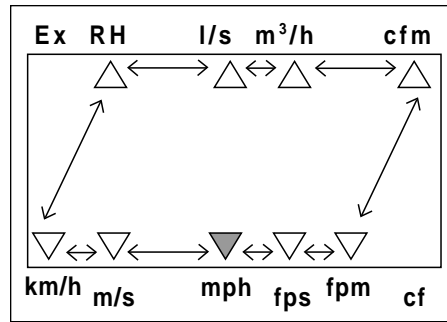

Fig. 15—Display with annunciator and units of measure.

- Push the **UNIT** key until [UNIT] appears.
- Push ↑ until the display annunciator ▲ moves to m³/h, selecting cubic meters per hour.
- Push ↵ to select the measurement unit.

Note: *Not all units are achievable with the attached hood.*

To Hold a Reading (For storage or printing):

- Push the **HOLD** key briefly until the measured value flashes.
- Push **HOLD** again to **STORE** this reading to memory, or push **ON/OFF** to reject it and return to **RUN** mode.
- If the meter is attached to the base, you may also push the red button on the right handle for your hold functions.

Measurement Modes

You can set the APM 150 for temperature or volume measurement by pressing the **UNIT** key.

Volume Selection

(when a 175 or 275 probe is attached):

Air volume measurement is achieved by multiplying a velocity reading by an area.

- When you press the **VOL** key, the [VOL] menu appears on the display and provides a way to choose whether you are measuring by area (in square units) or by a round or rectangular cross-section.
- Make your selection by scrolling using the ↑ and ↓ keys, then pressing the ↵ key to accept your choice.

- If you choose to use a cross-section, you must then indicate dimensions as follows.

Area:

(Also to review the Area or selected horn)

When selected by pressing the \downarrow key, the following will appear:

- The current units, either ft² [F t 2] or m² [m 2]
- The current horn (if previously used)
- The numeric value of the calculated area.

Note: *If you only wanted to review, press the ON/OFF key.*

- If you press the \downarrow key, the \uparrow or \downarrow key (value change), then the \downarrow key, you change the method of measurement to [R r E R].

Rectangular:

- After [r E c t] is selected, the display will show starting X dimension values [1 2 . 0] in inches or [0 . 5 0] meters. Accepting the X value affects choice of a volume dimension (e.g. cfm).
- Change these values using \uparrow or \downarrow . Press the \downarrow key to accept.
- The next display shows desired Y dimension values of [1 2 . 0] in inches or [0 . 5 0] meters.
- Change these values using \uparrow or \downarrow . Press the \downarrow key to accept.

Round:

- After [r n d] is selected, the display will show starting point diameter values [1 2 . 0] in inches or [0 . 5 0] meters.
- Change the value to the necessary diameter using \uparrow or \downarrow . Press the \downarrow key to accept.

Horn:

- When selected, use the \uparrow or \downarrow keys to scroll through the following options:
 - AM100 [R n 1]
 - AM300 [R n 3]
 - AM600 [R n 6]
 - AM1200 [R n 12]

- Press \downarrow to select one of these choices.
- To review, see Area.

Data Storage

All measurements stored in the instrument's memory are recorded on pages. A page is created whenever:

- the unit of measurement changes,
- or page is selected from the **MENU**.

For example, if you are measuring feet per second and decide to take measurements in miles per hour, a new page will be created.

The APM 150 memory has a total capacity of 100 sets of data. This means you can have one page of 100 lines, or one hundred pages of one line, or any combination of pages and lines totaling 100 readings.

Each time the **HOLD** key is pressed for the "second" time, the instrument will store measurements and the correction factor. Readings are stored in battery-backed memory so that powering off or changing batteries does not erase readings. These stored readings will remain in memory until they are cleared or if the instrument is damaged or malfunctions.

A copy of this data can be obtained if a printer or computer is attached to the instrument.

If a printer is connected:

- Press the **MENU** key, then the \uparrow or \downarrow key until [P r n t] appears.
- Press \downarrow to print the data.
- To escape from the print routine, press and hold the **ON/OFF** key until [P r n t] appears, then press the **ON/OFF** key to return to the **RUN** mode.

To erase stored data:

- Press the **CLR** key until [C l r] appears.
- Push the \uparrow or \downarrow key until [Y E S] appears.
- Press \downarrow to clear the memory.

Note: *Keep in mind that you cannot erase individual pages. Clearing data erases every page in the instrument's memory.*

TROUBLESHOOTING

Symptom	Probable Cause/Corrective Action
No Display	Instrument is not on. Press ON/OFF . Dead batteries. Replace batteries. Batteries incorrectly installed. Check polarity and correct if required.
LO BAT indication on	Battery voltage is low. Replace batteries.
Random pattern on display	Battery voltage is too low. Replace batteries.
Display does not change or flashes	HOLD/AVE button was depressed. Press hold again to release. Very stable input. Meter could be in another mode besides RUN .
Display shows [0]	Input condition below minimum allowed. See SPECIFICATION section of manual for limits.
Display shows [0 r]	Input condition above maximum allowed. See SPECIFICATION section of manual for limits.
Display shows [OPEN]	Probe or sensor not connected or loose. Check connection to meter. Tighten connector if required. Probe or sensor damaged. Call Alnor.
HOLD/AVE button on handle does not work	Connector between handle and meter is not plugged in. Connect hold cable to sensor module.
Measurement is erratic	Input is unstable. Interpret value from high and low display limits or increase time constant setting.
Erroneous readings	Wrong measurement units. Verify correct units. Hood frame not sealing properly around diffuser or grill. Press hood evenly against diffuser. Hood torn. Replace or repair hood.
Supply/Exhaust	Exhaust mode was incorrectly chosen when measuring supply flow or vice versa. Check mode. Display shows “▲” sign for exhaust mode. Absence of “▲” indicates supply mode. Use key to select desired mode. <i>Note: meter always starts up in supply mode.</i> Connection between manifold and sensor/meter is broken. Call Alnor. Manifold is damaged. Call Alnor. Manifold holes are plugged. See Maintenance section of manual. Condensation inside sensor module. Allow unit to warm up to room temperature.
Will not transmit data to computer	Make sure the terminal is set properly. The serial port must be enabled.

MAINTENANCE

Nylon Hoods

The hoods may be hand washed periodically using cool water and mild detergent. When washing, do not let the material come in contact with sharp corners or other objects which may tear the hood.

Manifold

The manifold should be checked before using to be certain that the sensing holes have not become

clogged with dirt or dust particles. Inspect for leaks which may be caused by a poor connection to the sensor housing through the long pieces of flexible tubing. Also check to make sure that the O-rings used to seal the tubes to the center hub are in place. The manifold may be cleaned using mild detergent and warm water. Do not immerse the manifold in water. It is recommended that cleaning be done with the manifold in place, and with care.

WARRANTY

Alnor Instrument Company (Alnor) warrants this product to be free of defects in material and workmanship for a period of two years from the date of original purchase. If the product should become defective during the warranty period, Alnor will repair it or elect to replace it free of charge under the following conditions:

1. Product is returned postpaid per the instructions for return, located in the owner's manual.
2. Owner submits proof of original date of purchase.
3. Alnor will inspect product for defects in material and workmanship. Alnor's decision as to existence of defect, and in the case of defect, to repair or replace will be final.

THIS WARRANTY IS EXCLUSIVE. THERE ARE NO OTHER WARRANTIES EITHER

EXPRESSED OR IMPLIED. SPECIFICALLY AND WITHOUT LIMITATION, THERE IS NO WARRANTY, EXPRESSED OR IMPLIED, OF MERCHANTABILITY OR FITNESS FOR PARTICULAR PURPOSE.

This warranty is void if product is misused, used contrary to procedures set forth in the owner's manual, or if product is serviced by anyone other than Alnor's authorized service. This warranty does not cover consumables such as light bulbs, paper, batteries, etc.

Alnor's liability for this product is limited to the above stated warranty and shall not in any event exceed the cost of the product. In no event will Alnor be liable for any direct or consequential damages, including but not limited to lost profits, loss of use, inaccuracies, loss of data, dismantling or reinstallation.