



OPERATION MANUAL

MODEL CLI-1750/LST-1700

HOME WIRING TEST SYSTEM

This document contains information proprietary to Wavetek Wandel Goltermann. The information in this document is not to be used or duplicated in any manner without the prior approval, in writing, of Wavetek Wandel Goltermann.

Wavetek Wandel Goltermann
CATV Division

5808 Churchman Bypass
Indianapolis, IN 46203-6109
(800) 851-1198
(317) 788-9351
Fax: (317) 614-8313
E-Mail: catvsupport@wavetek.com
Internet: <http://www.wavetek.com>

11/99 Rev. E
Manual Part No.
6510-00-0291

Copyright © 1999 Wavetek Wandel Goltermann

WARRANTY

Wavetek Wandel Goltermann warrants that all Products manufactured or procured by Wavetek Wandel Goltermann conform to Wavetek Wandel Goltermann's published specifications and are free from defects in materials and workmanship for a period of one (1) year from the date of delivery to the original Buyer, when used under normal operating conditions and within the service conditions for which they were designed. This warranty is not transferrable and does not apply to used or demonstration products.

The obligation of Wavetek Wandel Goltermann arising from a Warranty claim shall be limited to repairing, or at its option, replacing without charge, any assembly or component (except batteries) which in Wavetek Wandel Goltermann's sole opinion proves to be defective within the scope of the Warranty. In the event Wavetek is not able to modify, repair or replace nonconforming defective parts or components to a condition as warranted within a reasonable time after receipt thereof, Buyers shall receive credit in the amount of the original invoiced price of the product.

Wavetek Wandel Goltermann must be notified in writing of the defect or nonconformity within the Warranty period and the affected Product returned to Wavetek Wandel Goltermann's factory, designated Service Provider, or Authorized Service Center within thirty (30) days after discovery of such defect or nonconformity. Buyer shall prepay shipping charges and insurance for Products returned to Wavetek Wandel Goltermann or its designated Service Provider for warranty service. Wavetek Wandel Goltermann or its designated Service Provider shall pay costs for return of Products to Buyer.

Wavetek Wandel Goltermann shall have no responsibility for any defect or damage caused by improper storage, improper installation, unauthorized modification, misuse, neglect, inadequate maintenance, accident or for any Product which has been repaired or altered by anyone other than Wavetek Wandel Goltermann or its authorized representative or not in accordance with instructions furnished by Wavetek Wandel Goltermann.

The Warranty described above is Buyer's sole and exclusive remedy and no other warranty, whether written or oral, expressed or implied by statute or course of dealing shall apply. Wavetek Wandel Goltermann specifically disclaims the implied warranties of merchantability and fitness for a particular purpose. No statement, representation, agreement, or understanding, oral or written, made by an agent, distributor, or employee of Wavetek Wandel Goltermann, which is not contained in the foregoing Warranty will be binding upon Wavetek Wandel Goltermann, unless made in writing and executed by an authorized representative of Wavetek Wandel Goltermann. Under no circumstances shall Wavetek Wandel Goltermann be liable for any direct, indirect, special, incidental, or consequential damages, expenses, or losses, including loss of profits, based on contract, tort, or any other legal theory.

Extended Warranty Programs

Extended warranties and service contracts are available for new and currently owned equipment for an additional cost. Contact the Customer Service Department (800 851-1198) for details pertaining to extended warranties and service contracts.

Return Authorization Procedure

The customer MUST obtain a RETURN AUTHORIZATION NUMBER from the Customer Service Department (800 851-1198) prior to returning any equipment for warranty or non-warranty repair. Wavetek accepts no liability for any instrument or subassembly returned to the factory without this number. Any correspondence regarding returned instruments or subassemblies should be referenced to that number.

Contents

Introducing the CLI-1750/LST-1700 Home Wiring Test System	1-1
Introduction	1-1
Signal Level Measurements	1-1
Digital Carrier Measurement Option 1750DIG	1-2
Frequency Response	1-3
Fault Location	1-3
Ingress	1-4
Leakage Detection	1-4
Automated Signal Level Measurements	1-5
StealthWare Compatibility	1-6
Docking Station Option DS-1	1-6
Getting Acquainted with the LST-1700	1-8
Getting Acquainted with the CLI-1750 Keypad	1-12
Getting Acquainted with the Screen	1-15
The Navigator	1-17
Configure	1-18
Global Configuration	1-19
Measurement Configuration	1-22
Leakage Configuration	1-26
Channel Plann Configuration	1-28
Ingress Configuration	1-39
Transmitter Configuration	1-40
Sweep Mode	1-41
Locate Mode	1-44
Using the CLI-1750/LST-1700	2-1
Introduction	2-1
Leakage	2-1
Annunciators	2-2
Measurement Peak	2-3
Adjusting the Alarm Volume	2-3
Selecting the Antenna Type	2-3
Entering the Leakage Distance	2-4
Compensation	2-5
Searching for a Leak	2-6
Measurement Hold	2-7

Printing the Screen	2-7
Warning Indicators	2-7
Sweep	2-8
Moving the Markers	2-9
Adjusting the Reference Level	2-10
Adjusting the Scale	2-10
Zooming In and Out	2-10
Measurement Hold	2-10
Printing the Screen	2-10
Storing a Sweep File	2-10
Locate	2-11
Amplitude Marker	2-12
Distance Markers	2-12
Adjusting the Scale	2-13
Zooming In and Out	2-13
Velocity of Propagation	2-13
Resolution	2-15
Harmonic Filter	2-16
Measurement Hold	2-16
Printing the Screen	2-17
Storing a Locate File	2-17
Installation	2-17
Selecting Channel Packages	2-17
Selecting the Test Point	2-18
Installation Results Summary	2-18
The Channel List	2-19
The Pass/Fail Indicator	2-20
Channel Measurement	2-21
Printing an Installation Report	2-21
Storing Installation Results	2-21
Level	2-22
Adjusting the Reference Level	2-22
Tuning by Channel	2-22
Tuning by Frequency	2-23
Measuring Digital Carriers	2-23
Measurement Hold	2-26
Printing the Screen	2-26
Warning Indicators	2-26
Full Scan	2-27
Moving the Marker	2-27

Adjusting the Reference Level	2-27
Adjusting the Scale	2-28
Zooming In and Out	2-28
Checking Limits	2-28
Checking Limits on an Individual Channel	2-30
Measurement Hold	2-30
Printing the Screen	2-31
Storing a Scan File	2-31
Warning Indicators	2-31
Tilt	2-31
Moving the Marker	2-32
Selecting the Low and High Carriers	2-32
Adjusting the Reference Level	2-32
Adjusting the Scale	2-33
Measurement Hold	2-33
Printing the Screen	2-33
Storing a Tilt File	2-33
Scan	2-33
Moving the Marker	2-34
Adjusting the Reference Level	2-34
Adjusting the Scale	2-34
Checking Limits	2-34
Measurement Hold	2-35
Printing the Screen	2-36
Storing a Scan File	2-36
Auto Test	2-36
Configuring an Auto Test	2-36
Performing an Auto Test	2-39
Canceling an Auto Test	2-40
View	2-41
The File Directory	2-41
Viewing Installation Files	2-42
Viewing Scan Files	2-43
Viewing Auto Test Files	2-44

Ingress	2-47
Moving the Marker	2-48
Adjusting the Reference Level	2-48
Adjusting the Scale	2-48
Zooming In and Out	2-48
Resolution	2-48
Peak Measurement Hold	2-49
Measurement Hold	2-49
The Pass/Fail Indicator	2-49
Printing the Screen	2-49
Storing an Ingress File	2-50
Reference	3-1
Using the Reference Section	3-1
Help	3-1
Information	3-2
Technical Support	3-3
Appendices	
Appendix A: Specifications	A-1
Model CLI-1750 Specifications	A-1
Model LST-1700 Specifications	A-4
Appendix B: Power Management and Battery	B-1
Battery Pack Location and Installation	B-1
Charging the Battery Pack	B-1
Battery Tips	B-1
Appendix C: Interface Port	C-1
Connector	C-1
Cable Specifications	C-2
Appendix D: Setting up a Calibrated Leak Field	D-1
Introduction	D-1
Setup	D-2
Calibration	D-3
Appendix E: Technical Note - VMA-3	E-1
Introduction	E-1
Installation	E-1
Operation	E-2
Care and Maintenance	E-3

MODEL CLI-1750/LST-1700

1 Introducing the CLI-1750/LST- 1700 Home Wiring Test System

INTRODUCTION

The Home Wiring Test System consists of the Model CLI-1750 Signal Level / Leakage Meter and the Model LST-1700 Signal Transmitter. Together, the CLI-1750 and LST-1700 perform a comprehensive set of tests to help installers identify and locate potential problems with home wiring prior to activating new services. These tests include: signal level measurements, frequency response, fault location using a unique frequency domain relectometry (FDR) measurement, reverse ingress, and leakage detection.

Other features include a digital carrier measurement option, automated signal level measurements for acquiring proof-of-performance compliance data, StealthWare compatibility and a docking station option. The CLI-1750 has an icon-based user interface and an easy to read, high resolution LCD display. All of these features are in a portable, easy to use, economical package.

SIGNAL LEVEL MEASUREMENTS

Signal levels are checked to verify proper levels arriving at the tap and the house according to design and government regulations. Your CLI-1750 performs accurate signal level measurements - even on scrambled channels with horizontal or vertical sync suppression. The CLI-1750 tunes from 5 to 890 MHz.

A scan mode allows you to see the levels of all carriers in a spectral display. You can also view level measurements at a single frequency or for a specific channel. When tuned to a channel, the display indicates the levels of the video and audio carriers, and the difference between the carrier levels.

When performing an installation, you can press the Installation Check key to quickly verify that all channels are within limits that you have defined. You can use this feature to determine whether or not a subscriber connection meets government regulations.

You can store installation checks that you have performed throughout the day. You can also store scan and tilt measurements. Each file is time and date stamped and can be recalled later for viewing on the LCD screen. When viewing a file, you can adjust the screen settings the same as when you are viewing a “live” measurement. Using the built-in serial port, you can print files and upload them to StealthWare, the Windows(tm) based data management package for Stealth products, for further analysis and archiving.

A special channel plan building mode automatically determines which channels are active on your cable system. Once you have defined a channel plan, you can copy it to other units. You can store channel plans that you have built and edited. This is convenient if you use your CLI-1750 for more than one plant. You can quickly select the correct channel plan for the plant at which you are working. You can also create channel plans using StealthWare.

For documentation purposes, you can print any measurement screen to a serial printer (Wavetek P-Stealth Printer). Following an installation check, you can print an installation report and file it with the work order. You can also print a report that lists all configuration settings including the channel plan.

DIGITAL CARRIER MEASUREMENT OPTION 1750DIG

As digital services such as audio, video, Internet, and telephony become more common, a way of accurately measuring their carriers is needed. The 1750DIG digital carrier measurement option provides an average power measurement of QPSK, 16-QAM, 64-QAM, 256-

QAM, QPR, BPSK, CAP-16, and other modulation schemes. To be measured, carriers must be in a state of continuous (i.e., non-burst) transmission.

FREQUENCY RESPONSE

Frequency response is measured to verify that all home wiring components are capable of transmitting video and data signals into the residence without significant amplitude loss or distortion.

The LST-1700 Signal Transmitter generates a sweep signal which you can insert at the tap end of the drop cable or ground block. You can then use the CLI-1750 to view the frequency response at each subscriber terminal location. Frequency response problems are typically displayed as standing waves, band roll-off or frequency suckouts. Viewing the response will help you determine if the home wiring includes unterminated splitters or wall plates that may cause troublesome microreflections.

FAULT LOCATION

The frequency domain reflectometry (FDR) test reveals the location and severity of sources of reflections. This facilitates the replacement of faulty cable and components or the repair of craftsmanship problems.

Your LST-1700 Signal Transmitter provides a source for a frequency domain reflectometry test of home wiring to help locate faults. Frequency domain reflectometry is a method of determining transmission characteristics by analyzing the reflections in a sweep response. An FFT (Fast Fourier Transform) is performed on the response to determine the frequencies of reflection components. This analysis provides a display of reflection components in an amplitude vs. distance graph that is displayed on your CLI-1750. The highest reflections will emanate from the points in the transmission medium that have the worst impedance match relative to the source. For instance, if the cable is broken or unterminated a large reflection will occur.

INGRESS

With the growing deployment of digital carrier transmission, guarding against ingress becomes more and more important. The ingress measurement reveals the presence of any noise or ingress generated within a home that can hinder communications for all customers sharing the same node.

The ingress measurement is a standard feature of the CLI-1750. Following the completion of an installation, you can connect your CLI-1750 to the tap end of the drop and check for ingress. You can select the start and stop frequencies and desired resolution. To check for intermittent ingress, you can enable a peak hold mode for catching transient signals. A pre-programmable limit allows for easy Pass/Fail testing. The screen can be saved for later viewing, printing or downloading to StealthWare.

LEAKAGE DETECTION

A leakage test finds potential points of ingress within a home. Most cable systems are implementing processes that require the installer to certify the installation by checking for leaks at the completion of the install. This will ensure that there are no leaks, and this commonly correlates to no ingress.

The CLI-1750 is a highly sensitive leakage meter that makes finding the source of RF leaks easy. An audible alarm notifies you when your CLI-1750 has detected a leak. You specify the level threshold at which the alarm is triggered. To reduce the likelihood of false alarms, you can configure the alarm to occur only when a tag signal is present. You can quickly adjust the volume of the alarm and even mute it if desired.

You can use your LST-1700 Signal Transmitter as an RF source when searching for leakage. It has a CW mode for generating a carrier at the frequency you specify. It can even modulate this carrier with a tagging signal for easy identification.

The CLI-1750 can also be used by dedicated leakage crews to perform accurate leakage measurements that are needed to verify compliance with government regulations. Because it can accurately

detect and measure video signals, it is not necessary to inject an additional RF carrier for the purpose of monitoring leakage. Your CLI-1750 is frequency agile - you can configure it to monitor a carrier frequency between 115 to 140 MHz.

You can use the optional LT1000 Leakage Tagger to modulate an existing carrier with a distinct tag signal. This enhances detection sensitivity in noisy environments and reduces false alarms. In over-build situations, you can determine if a detected leak is emanating from the network that you are testing.

The type of antenna you are using and the distance from the leak are considered when measuring field strength. You can select from among four antenna types - monopole, dipole, vehicle mount and custom. The antenna factor for each type is programmable. The most accurate and repeatable measurements are made using a dipole antenna located at the required reference distance. This is the only method recommended by Wavetek Wandel Goltermann for making compliance measurements. You can also make approximate measurements up to 30 meters away by entering the estimated distance from the leak. Your CLI-1750 will calculate what the equivalent field strength would be at the reference distance. These measurements are adequate for grading leaks you have found and prioritizing your repair schedule based on leak severity.

AUTOMATED SIGNAL LEVEL MEASUREMENTS

Automated tests are easy with the CLI-1750 and provide a convenient way of acquiring proof-of-performance compliance data. Tests can be executed immediately or scheduled over a period of time. To conserve battery life, your CLI-1750 shuts itself off between scheduled intervals. When configuring an automated test, you can record information about the location at which the test is being performed. Files can be created for commonly tested locations so you need only enter the information once.

Measurement results are time, date, and temperature stamped and can be viewed on the LCD screen. Limits are applied to the measurement data with out-of-tolerance conditions concisely indicated. You can print a test report for each interval or a comprehensive 24-hour report that summarizes data collected from up to 4four intervals.

STEALTHWARE COMPATIBILITY

Information stored on the CLI-1750, including screens, automated measurement results, channel plans, etc. can be uploaded to a PC for archiving and further analysis using WWG's StealthWare data management package.

DOCKING STATION OPTION DS-1

The DS-1 docking station simplifies connection to a vehicle antenna and power source. The adjustable arm makes it easy to view your CLI-1750's display from the driver's seat. The CLI-1750's batteries charge while it rests in the docking station.

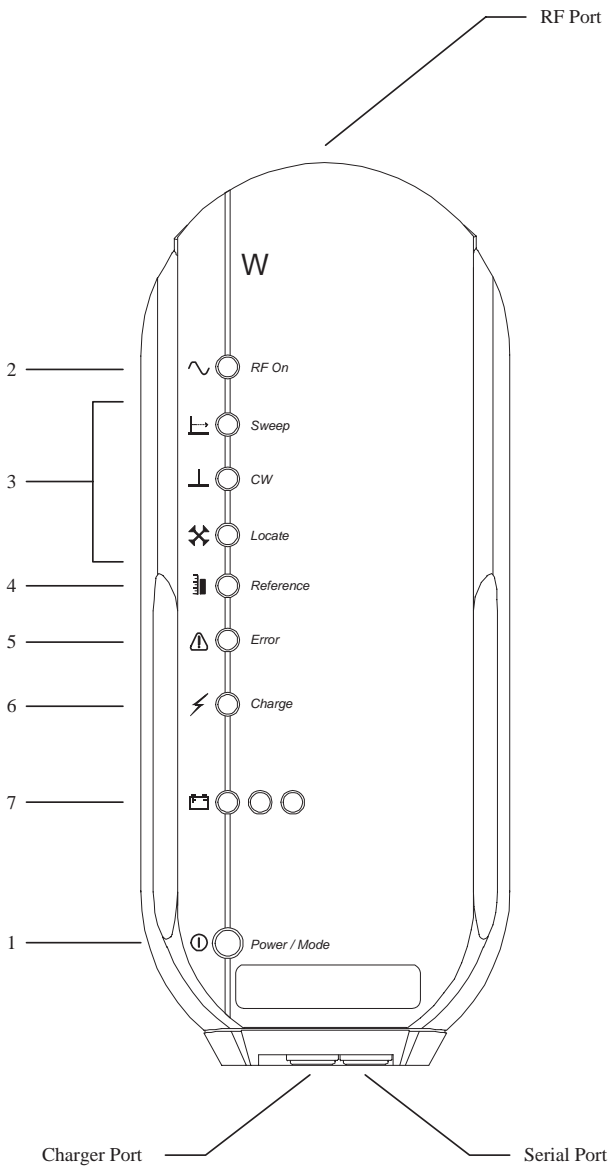

GETTING ACQUAINTED WITH THE LST-1700

The LST-1700 is a Signal Transmitter used in conjunction with the CLI-1750 for sweeping an inactive cable and for finding faults via a Frequency Domain Reflectometry (FDR) measurement.

1. **POWER / MODE SELECTION BUTTON**

Press this button to turn your LST-1700 on.

When the LST-1700 is powered on, each subsequent press of the Power/Mode button toggles between Sweep and CW modes (see below).

Press and hold this button to turn off your LST-1700.

NOTE

To turn the LST-1700 off, you must press and hold the Power/Mode button for approximately two seconds.

2. **RF ON INDICATOR**

Illuminates whenever the output of RF Port is active.

3. **MODE SELECTION INDICATORS**

Shows which mode is currently selected.

SWEEP MODE

Generates a sweep signal for use in frequency response measurements.

CW MODE

Generates a CW signal for use in leakage detection and other tests.

NOTE

Press the Power/Mode button to select between SWEEP and CW modes.

LOCATE MODE

Generates a Frequency Domain Reflectometry (FDR) source for locating faults.

NOTE

LOCATE mode is automatically enabled by the CLI-1750 when you enter the LOCATE screen. It cannot be selected with the Power/Mode button.

4. REFERENCE INDICATOR

Illuminates when a reference sweep occurs during Locate mode or when you manually Normalize the transmitter (see Transmitter Configuration). The purpose of the reference sweep is to compensate for any variation in the output level of the LST-1700.

5. ERROR INDICATOR





Illuminates if an internal hardware problem exists. Cycling the power may resolve the problem. If the error condition persists, please contact your nearest WWG Service Center.

6. CHARGE INDICATOR

Illuminates when the external charger is properly connected.

7. BATTERY LEVEL INDICATOR

Indicates the current state of battery charge.

	Full	3.5 to 4 hours remaining
	Partial	0.5 to 3.5 hours remaining
	Low	2 to 30 minutes remaining
	Empty	less than 2 minutes remaining

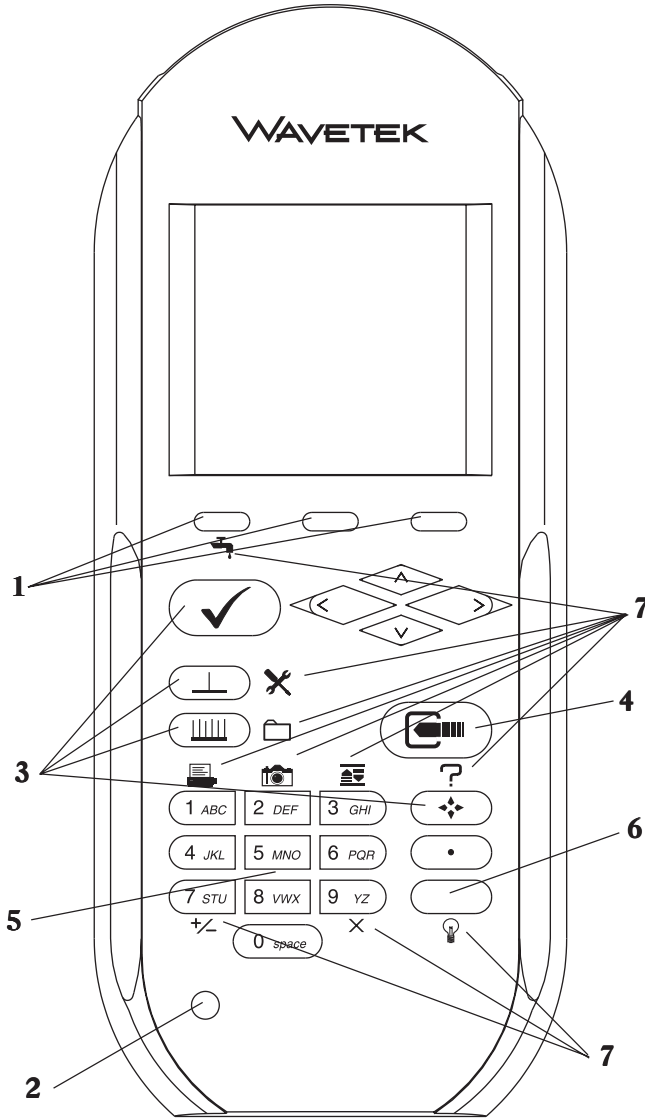

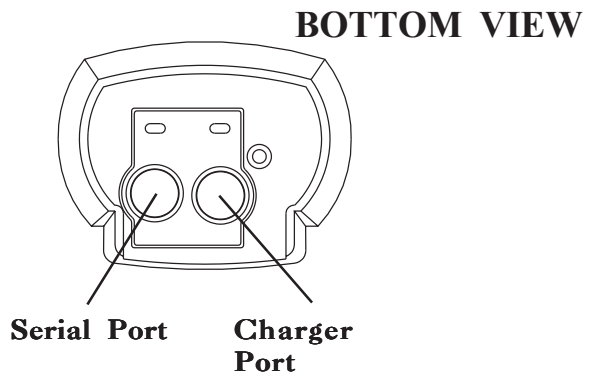
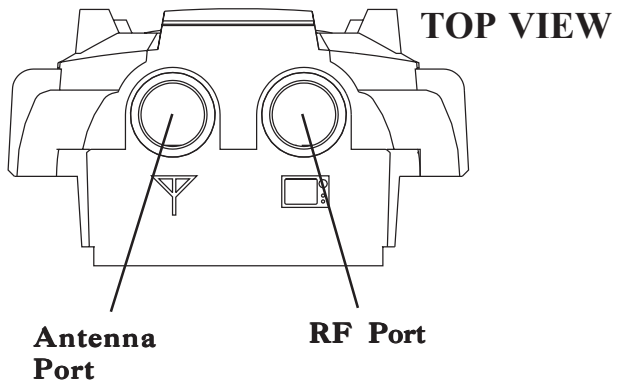
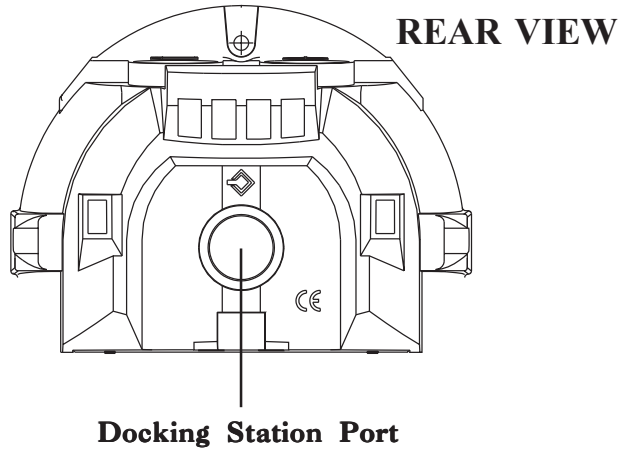

TEST MODE

A special Test mode is available for upgrading your LST-1700's firmware and checking the LED indicators. With the unit turned off, press and hold the Power/Mode button. The LEDs will sequentially illuminate from the top down. Release the Power/Mode button when all LEDs are lit. The LEDs will flash indicating that your LST-1700 is now in Test mode. To exit Test mode, simply turn the unit off.

NOTE

The Charge LED will not be illuminated in Test mode unless the charger is connected.

GETTING ACQUAINTED WITH THE CLI-1750 KEYPAD

The keypad consists of the following:

- three Soft keys
- a Power key
- four Mode Selection keys
- an Enter key
- eleven Alphanumeric keys
- a Shift key

1. SOFT KEYS

There are three horizontally oriented soft keys located below the display. The function of each soft key changes depending on the particular operation being performed and is represented by an icon immediately above the key.

2. ① POWER KEY - ON/OFF

Turns your CLI-1750 on and off.

3. MODE SELECTION KEYS



INSTALLATION MODE

Easily check the channels that you have installed and verify that they are within limits.



LEVEL MODE

Measure the signal level at a specific channel or frequency.



FULL SCAN MODE

View a spectrum graph of all carrier levels in your channel plan.



NAVIGATOR

Instantly "travel" to any mode using the NAVIGATOR.

4. ENTER KEY

Press this key to terminate your entry or selection.

5. ALPHANUMERIC KEYS

You use the alphanumeric keys to enter data while operating your CLI-1750. Notice that these keys have a numeral and up to three alphabetic characters labeled on them. You can only access the characters when alphanumeric entry is appropriate. In the alphanumeric entry mode, you sequence through each character and the numeral by repeatedly pressing the key. You can also access a set of special characters that do not appear on the keypad by using the up and down arrows. Once the desired character is displayed, move the cursor to the next position using the right arrow. Be sure to terminate your entry by pressing the  key.

6. SHIFT KEY

Some keys perform more than one function. The secondary function of a key is represented by an icon printed next to it. Notice that the icons are color coded with the **SHIFT** key (Green Button). You access the secondary function by first pressing the **SHIFT** key and then the icon representing the desired function.

7. SECONDARY FUNCTIONS



LEAKAGE MODE

Detect and measure RF leakage



CONFIGURE MODE

Configure your CLI-1750 for your own specific needs.



AUTO REFERENCE

Let CLI-1750 automatically set the reference level for you.



SNAP SHOT

Hold the measurement. The measurement is retained even if the cable is disconnected from the input.



CLEAR

Clear-out your entry and start over again.



BACKLIGHT ON/OFF

Quickly turn the backlight on when it is too dark to see the display.



POSITIVE/NEGATIVE

Enter positive and negative values (when allowed).



HELP

View a description of each icon found in the current soft key menu.



PRINT

Print a measurement screen, installation report, auto test report, or configuration report to a serial printer.



STORE FILE

Store an Installation, Scan, Sweep, Locate or Tilt screen for later viewing, printing or uploading to StealthWare (Version 4.0).

GETTING ACQUAINTED WITH THE SCREEN

There are certain elements of the screen that will become familiar to you as you use your CLI-1750.

The Title Bar

Notice the title bar at the very top of the screen. It presents the title and icon for the current mode you are using.



Title Bar Indicators

You may see indicators appear above the title bar from time to time. This is what they represent:



This indicator appears in the top right-hand corner of the screen when you press the SHIFT key. This means that the CLI-1750 interprets the next key that you press to be a secondary function.



This indicator is displayed to warn you that the battery is low. When you see this, recharge the battery or change to a fresh one as soon as possible.



This indicates that the RF synthesizer has become unlocked. If this condition persists, please contact the nearest Wavetek Service Center.

The Status Bar

Look for the status bar in the lower portion of the screen. It displays the current date and time. A bar meter indicates the charge remaining in your CLI-1750's battery. When the battery meter reads low, you should switch to a freshly charged battery soon.

NOTE

When viewing an Installation or Scan file, the status bar shows the date and time that the file was stored instead of the current date and time.

Soft Key Icons

There are three soft keys located immediately below the display. The function of a soft key is represented by the icon directly above it.

NOTE

If the soft key function is not currently available, the icon appears "grayed" or "dimmed".

Lists

Lists present several items for viewing and/or selecting. Notice that the currently chosen item is highlighted. You can scroll through the list using the up and down arrows.





A list can be either "active" or "inactive". You can tell by looking at the border. If the border is solid, the list is active and any keys that you press are directed toward it. If the border is dim, the list is inactive and is not affected by key presses. Usually you can make a list become active by pressing the  key.

When there are more items in the list than can be displayed at one time, a scroll bar appears along the right-hand edge of the list. You can use this to get an idea of where you are. When you have reached the first or last item, an arrow appears inside the scroll box pointing to the direction you can go.

The Edit Box

The edit box appears in the lower portion of the screen when it is necessary to enter values into your CLI-1750.





An edit box can be either “active” or “inactive”. You can tell by looking at the border. If the border is solid, the edit box is active and any keys that you press are directed toward it. If the border is dim, the edit box is inactive and is not affected by key presses. Usually, you can make the edit box become active by pressing the  key. Be sure to press the  again when you have finished making your entry.

THE NAVIGATOR

You can easily travel to any mode using the NAVIGATOR. To access the NAVIGATOR, press the  key.



An icon appears on the screen for each available mode. Use the up, down, left, and right arrows to highlight the icon that represents the mode you want to use. Notice that the name of the mode appears on the lower portion of the screen beneath the status bar. To get a description of the highlighted mode, press the SHIFT +  key. To travel to the mode you have highlighted, press any one of the soft keys or the  key.



TIP

You can also use the numeric keys to highlight the desired icon in the NAVIGATOR screen. Each key corresponds to an icon in the matrix.



CONFIGURE

Before using your CLI-1750, you may want to configure it for your specific needs. The CONFIGURE mode allows you to select global, leakage, measurement, ingress and transmitter related preferences and to build and edit a channel plan that matches your cable plant.

To configure your CLI-1750, press the SHIFT +  keys or choose the  icon from the NAVIGATOR. The following screen appears:



Configuration settings are divided into six categories; GLOBAL, MEASUREMENTS, LEAKAGE, CHANNEL PLAN, INGRESS and TRANSMITTER. Use the up and down arrows to highlight the category you want and then press the  key.

TIP

You can also use the left-hand and right-hand soft keys to scroll through the CONFIGURE categories and then press the middle soft key to select the highlighted category.

PRINTING A CONFIGURATION REPORT

In most configuration screens, you can print a comprehensive configuration report by pressing the SHIFT +  keys. A bar graph appears indicating the status of the printout. The report lists all of the configurable settings including the active channel plan.



Global Configuration

OPERATOR NAME

You can personalize your CLI-1750 by entering your name here. Your name will then appear on report printouts.

CONTRAST LEVEL

Adjusts the contrast level of the LCD for optimum viewing.

NOTE

The contrast of the LCD is affected by variations in temperature. Your CLI-1750 will automatically optimize the contrast level based on the current temperature as measured from the built-in sensor.

SHUTOFF TIME-OUT

Sets the amount of inactive time allowed before your CLI-1750 turns off automatically. This feature is useful for conserving battery life by preventing the CLI-1750 from being left on accidentally when it is not in use. You can set the time-out period to 1, 3, or 5 minutes. There is also an "always on" setting that defeats the automatic shutoff feature if desired. (IMPORTANT: Before performing Scheduled Auto Tests, make sure that the unit's Shutoff Time-out is NOT programmed for "always on". Program the Shutoff Time-out for 1, 3 or 5 minutes.)

NOTE

You can manually turn off your CLI-1750 at any time by pressing the  button.

NOTE



The Shutoff Time-out feature is disabled during LEAKAGE mode.

BACKLIGHT TIME-OUT

Sets the amount of inactive time allowed before the backlight turns off automatically. The backlight consumes significant power. This feature conserves battery life by minimizing the amount of time that the backlight is on. You can set the time-out period to; 5 or 10 seconds. There is an "always off" setting for when the backlight is not needed at all. There is also an "always on" setting that defeats the backlight time-out feature.

You can manually turn the backlight on or off at any time by pressing the SHIFT +  keys. When manually activated, the backlight remains on continuously until the unit shuts off.

TIP

You can tell when the backlight is on even in bright sunlight by looking for the backlight indicator at the left-hand edge of the Title Bar. The  indicator means that the backlight is currently on and will turn off automatically. The  indicator means that the backlight is on and will remain on continuously. If you see no indicator, the backlight is off.

TIME

Sets the time for the internal real-time clock. The time is set, displayed and printed in 24 hour format only (HH:MM:SS).

DATE FORMAT

You can specify the format in which the date is displayed and printed. Select between the following formats:

MM/DD/YY

DD.MM.YY

YY.MM.DD

DATE

Sets the date for the internal real-time clock. You can specify the format in which the date is set, displayed and printed (see DATE FORMAT).

PRINTER

Select the manufacturer of the printer that you will be using. A printer with a serial interface is required. Set your printer configuration as follows:

Baud Rate:	same as your CLI-1750
Date Bits:	8
Stop Bits:	1
Parity:	NONE
Flow Control:	Xon/Xoff

IMPORTANT

The baud rate of both your CLI-1750 and your printer must match (see BAUD RATE).

TIP

A serial to parallel converter (such as the one manufactured by Black Box Corp.) can be used for printing to a parallel printer.

LINES/PAGE

For text reports, you can specify the number of lines that will be printed on each page before a form feed command is sent. Enter 0 if you do not want any form feeds to be sent.

BAUD RATE

This is the baud rate that is used when your CLI-1750 communicates with another device through the serial port. Generally, you will want to use the highest rate supported. Be sure that the baud rate setting of your CLI-1750 matches that of the device that it is connected to.

CLONE

You can easily transfer the entire configuration from one CLI-1750 unit to another. This saves you time when configuring multiple units. First, connect a cable between the two CLI-1750 units. Select **CLONE only on the unit that you want to copy the configuration to.**

Press the  soft key to begin the transfer. Cloning copies the configuration information and active channel plan only. If you wish to copy only channel plans, use the Copy Remote Channel Plan command.

IMPORTANT

Be sure that the baud rate setting of your CLI-1750 matches that of the device that it is connected to (see BAUD RATE).

DIAGNOSTICS

Performs hardware diagnostics and defaults stored preferences to factory presets. Press the  key to access the diagnostics options.

Factory Default

Sets all stored preferences to factory presets. Press the  key to initiate the default operation.

IMPORTANT

All stored settings are lost when you perform this operation.

Test Display

Exercises all pixels on the LCD for test purposes. Repeated pressing of the  key sequences the display between all pixels "on", all pixels "off", and the display test screen.



Measurement Configuration

TEMPERATURE UNITS

Selects the units in which temperature measurements are displayed and printed. You can select between; °C or °F.

DISTANCE UNITS

Select the units in which you want distance values to be displayed and entered. You can select between feet or meters.

SIGNAL LEVEL UNITS

Selects the units that will be used for all signal level measurements. You can select between; dBmV, dBμV and dBm.

PROBE COMPENSATION

This can be used to compensate for losses associated with probe points found on certain amplifiers. You can enter a value between -99.9 and +99.9 dB. Probe compensation is added directly to signal level measurements. The compensation value is indicated in the upper left-hand corner of the measurement screens. There is no indication, however, if the compensation value is zero.

IMPORTANT

The PROBE COMPENSATION value **does not affect INSTALLATION mode**. Level measurements made while checking an installation are uncompensated.

FREQUENCY TUNING STEP SIZE

This setting affects the increment/decrement step size when you are tuning the frequency using the left and right arrows. You can select a value between 25kHz and 100MHz in steps of 25kHz.

SCAN AUDIO CARRIERS

Select YES if you want to see the audio carriers in the full scan screen. You can achieve a faster scan by omitting the audio carriers.

SCAN SCRAMBLED CHANNELS

Select YES if you want to see scrambled channels in the full scan screen.

EDIT TEST POINTS

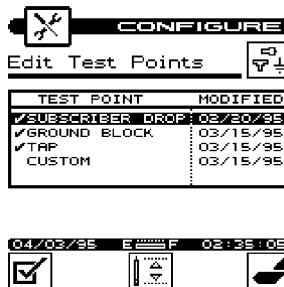

Your CLI-1750 is capable of performing tests at various locations including; SUBSCRIBER DROP, GROUND BLOCK, TAP, and USER DEFINED (or CUSTOM). Each test point has its own set of limits that you can edit. Press the  key to edit the test points. A list of available test points appears.



You can enable or disable each test point in the list. When a test point is disabled, you cannot use it when performing tests. Use the up or down arrow to highlight the desired test point. If the highlighted test point is disabled, you can enable it by pressing the  soft key. A



check mark appears in the left-hand column to indicate when a test point is enabled. If the test point is already enabled, pressing the  soft key disables it.

TIP

You can change the name of the USER DEFINED (CUSTOM) test point. Notice that the edit box appears when this test point is highlighted. When you press the  key, the edit box becomes active and you can enter any name up to fifteen characters long. Be sure to press the  key when finished to terminate your entry.

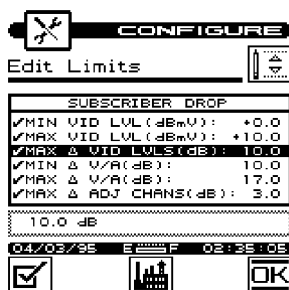
You can edit the limits for the highlighted test point by pressing the  soft key. The limits appear on the screen. Scroll down the list to see all the limits.





You can selectively enable or disable each individual limit. When a limit is disabled, your CLI-1750 excludes it when checking limits. If the highlighted limit is disabled, you can enable it by pressing the  soft key. A check mark appears in the left-hand column to indicate when a limit is enabled. If the limit is already enabled, pressing the  soft key disables it.

NOTE

If you disable all of the limits within a test point, the test point becomes disabled. You cannot enable a test point that has no enabled limits.

NOTE

If you disable all of the limits within a test point, the test point becomes disabled. You cannot enable a test point that has no enabled limits.

You can edit the value of the highlighted limit by pressing the  key. When the edit box becomes active, enter the desired value. Be sure to press the  key when finished to terminate your entry.

Press the  soft key to return all limits in the test point to their factory preset values.



CALIBRATION

Performs user calibration for optimum measurement accuracy. Press the  key to access the calibration options.

Noise Floor Correction

This calibration measures the noise floor of your CLI-1750. You should perform it periodically to ensure accurate measurements.

IMPORTANT

Before performing the Noise Floor Correction calibration, you should make sure that there is **nothing** connected to either the  or  ports (including Docking Station, DS-1) of your CLI-1750.

Press the  key to initiate the calibration procedure. Your CLI-1750 will guide you through the process.

IMPORTANT

The CLI-1750 meter assumes that leakage tag depth of modulation is set for 3 dB. This is precisely set on the WWG Model LT-1000 Leakage Tagger at the factory. If another manufacturer's tagger is used, some calibration of percent modulation may be necessary for optimal accuracy. Follow the tagger manufacturer's procedure for performing this calibration.



Leakage Configuration

ALARM CONDITION

This setting determines under what conditions the alarm is triggered. You can disable the alarm entirely if desired. Select from the following options:

- when the threshold is exceeded
- when a tag signal is detected
- when the threshold is exceeded and a tag signal is detected
- disable the alarm

ALARM THRESHOLD

This is the leakage measurement level at which the alarm will occur.

ALARM MUTE TIME-OUT

When performing leakage measurements, you can mute the audible alarm by pressing the  key. This setting determines the amount of time that will elapse before the alarm is reactivated.

LEAKAGE UNITS

This determines the units in which leakage is measured and the alarm threshold is set. You can select between; $\mu\text{V}/\text{m}$, $\text{dB}\mu\text{V}/\text{m}$, dBmV , $\text{dB}\mu\text{V}$, μV , dBm and $\text{dB}20\mu\text{V}$.

MEASUREMENT FREQUENCY

Enter the frequency of the carrier that you want to monitor for RF leakage. You can select from 115 to 140 MHz.

MEASUREMENT CARRIER TYPE

For accurate measurements, be sure to select the type of carrier that you will be measuring leakage on — either Continuous Wave (CW) or video.

TAG MODULATION FREQUENCY

Enter the modulation frequency to detect when searching for a tag. This should match the setting of the LT1000 Leakage Tagger that you are using. It is recommended that the tag modulation frequency be adjusted to a minimum of 20 Hz. By maintaining the 20 Hz tag criteria, false tags will be reduced while still preserving the video

quality of the tagged carrier. You can select a Tag Modulation frequency from 3 to 25 Hz.

REFERENCE DISTANCE

This is the specified distance at which leakage is to be measured. For example, in the United States, the FCC requires that all measurements be referenced to 3 meters or 10 feet. If your application requires a different reference distance, enter it here.



PEAK HOLD RESET PERIOD

The peak hold feature momentarily holds the peak leakage measurement value. This peak value is displayed numerically and indicated on the analog meter. This setting allows you to specify how often the peak hold value is reset. In the Find and Fix mode, the graph scale is updated to reflect the leakage reading in relation to the new peak value.

EDIT ANTENNA TYPES

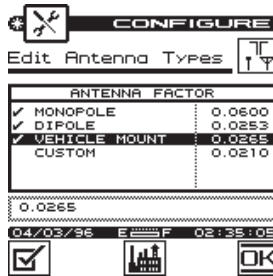
There are several different types of antennas that you can use with your CLI-1750 when measuring leakage. Press the  key to edit the antenna factor for each type.



You can edit the antenna factor of the highlighted type by pressing the  key. When the edit box becomes active, enter the desired value. Be sure to press the  key when finished to terminate your entry.

Press the  soft key to return the antenna factor of the highlighted type to its factory preset value. The factory preset antenna factor for

the dipole antenna corresponds to the HD-1 Dipole" Antenna that was shipped with your unit. If you choose to use another type of dipole antenna, you must change the antenna factor to that specified for the antenna.

You can enable or disable each antenna type. When a type is disabled, you cannot use it when performing tests. Use the up or down arrow to highlight the desired antenna. If the highlighted type is disabled, you can enable it by pressing the soft key. A check mark appears in the left-hand column to indicate when an antenna type is enabled. If the type is already enabled, press the soft key to enable it.



Channel Plan Configuration

What is a Channel Plan?

A channel plan is a framework of cable network parameters chosen by the user for his network. The basic entities are:

- Channel format (analog, digital, scrambled, etc.)
- System Bandwidth
- Test Limits (digital and analog)
- Carriers (audio and video)

Why do we need a Channel Plan?

A well thought-out channel plan is necessary for the proper operation of the unit. This is accomplished by specifying tilt and scan, and taking full advantage of the Auto Test and Installation Check features in the WWG instruments. Remember that the Wavetek instruments are capable of *learning* a channel plan from a cable system and storing it as a built-in plan.

How to build a Channel Plan?

Use the following step-by-step procedures to build a channel plan.

The starting point is the Configure screen. Press the Shift key and the Level/Configure key to bring up the Configure screen.

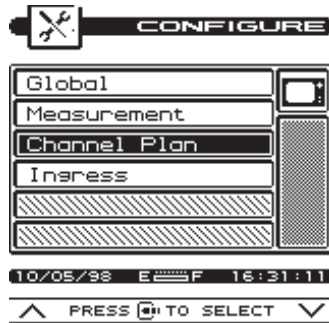

Using the up/down arrow keys, highlight Channel Plan and then press ENTER to bring up the Configure - Channel Plan screen. This screen lists the various ingredients/processes for building (configuring) a channel plan.



Select a Channel Plan

Use the up/down arrow keys to highlight SELECT CHANNEL PLAN and then press. This will bring up the Select Channel Plan screen showing the Default and other available channel plans stored in the unit. The currently active channel is denoted by an arrow tip to its left. To enable a different plan, use the up or down arrow to highlight and then press the center softkey. To delete a plan, press the left softkey.

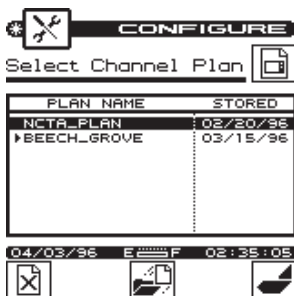

NOTE: You cannot delete a currently active plan. You must load a different plan first.

You may implement a plan from this list or let your instrument “learn” the cable plant’s existing channel plan. You may then edit it as desired.

To return to the Channel Plan screen, press the right softkey.

Select Video Signal Type

Highlight VIDEO SIGNAL TYPE from the Channel Plan screen (page 1-29). Choose from NTSC, PAL and SECAM types. Press **ENTER**.

Select Channel Sequence

Highlight CHANNEL SEQUENCE from the Channel Plan screen and press **ENTER** to make the Edit box active. Use up/down arrow keys to select numeric or frequency. Press **ENTER**.

NOTE: The SCAN screen always displays channels in order of frequency regardless of the CHANNEL SEQUENCE setting.

Learn the Channel Plan

The CLI-1750 is capable of identifying which channels are on your cable plant. This allows you to quickly and easily generate a customized channel plan.

With the instrument connected to the cable system, highlight BUILD CHANNEL PLAN in the Channel Plan screen (page 1-29) and then press ENTER. This will bring up the Build Channel Plan - STEP 1 screen.

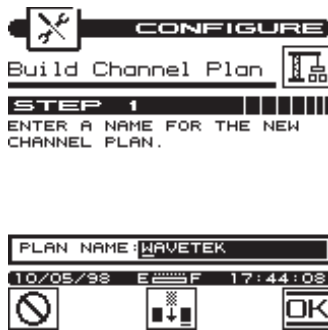

In the Edit box, type the name (up to 15 characters) of your channel plan and press ENTER. Press the softkey to proceed to the Build Channel Plan- STEP 2 screen. The screen contains a list of standard channel plans to serve as a basis for your own plan.

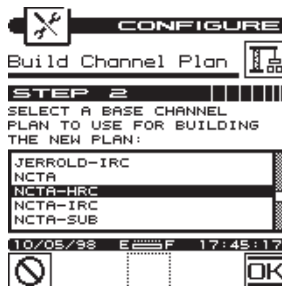

NOTE: If your system is a PAL M type, select NTSC for your channel plan.

Using up or down arrow key, highlight a base channel plan from the list and then press . Press the softkey to proceed to the Build Channel Plan - STEP 3 screen

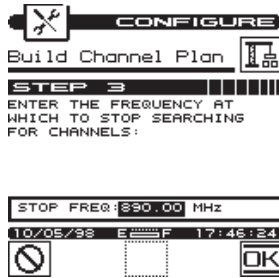

Using the numeric keypad, type in a value for the Stop Frequency in the Edit box and press . Then press the softkey. The unit will start searching for active channels and display the Build Channel Plan - STEP 4 screen.

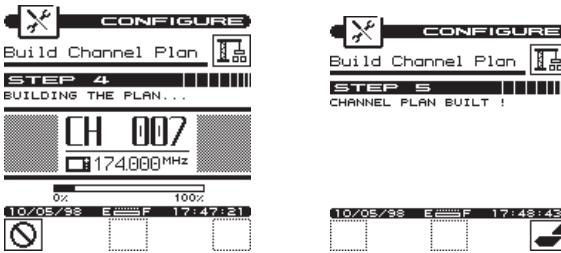

The unit will complete the build and display the Build Channel Plan-STEP 5 screen (shown right above).

Press the right softkey to return to the main Channel Plan menu.

How to Edit the Channel Plan

Why edit the Channel Plan?

An accurate channel plan is essential for testing the cable system, including limits for analog and digital carriers.

Editing is required to verify that the channel plan is built correctly (has the right parameters).

From the Channel Plan screen, use the up/down arrow keys to highlight EDIT CHANNEL PLAN, then press . This will bring up the Edit Channel Plan screen.

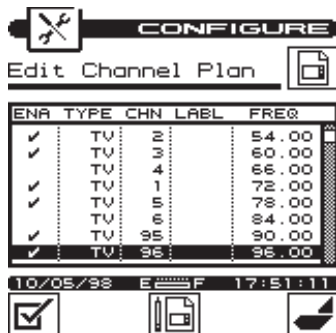

The screen contains a list of all channels, their frequencies and activation status (enabled channels carry a check mark under the ENA column). To disable a channel, highlight the channel and then press the left softkey.

To edit a channel's parameters, highlight that channel and then press the center softkey. This will bring up the Edit Channel screen.

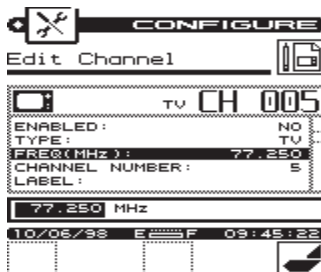

IMPORTANT: You may find an enabled channel that is not in your channel plan. This should be disabled. A channel may be missed if the frequency is special or level too low.

IMPORTANT: You must enable a channel to perform measurements on it.

Channel Plan Parameters/Characteristics to edit

The Configure- Edit Channel screen lists the following parameters/characteristics:

ENABLED
TYPE
FREQ(MHz)
CHANNELNUMBER
LABEL
CARRIER
CENTERFREQ(MHz)— Digital
MEAS BW (MHz)— Digital
PACKAGE
TAGGED
SCRAMBLED
AUD OFFSET(MHz)

Enabled

As mentioned earlier, a channel must be enabled in order to be measured. This is another place where you can enable or disable the channel.

Type

There are three channel types from which to choose:

- TV -the standard video and audio carriers
- DUAL -a video carrier with two independent audio carriers (a European format)
- SNGL -a single carrier

Carrier (SNGL Type only - 1750DIG Option)

Select the format of the carrier to be measured

- Analog
- QAM (Digital)
- QPSK (Digital)
- QPR (Digital)
- CAP-16 (Digital)

IMPORTANT: Digital signal level measurements are accurate only when performed on carriers that are in a state of continuous (non-burst) transmission.

Frequency

This is the frequency of the video carrier in MHz. For a digital channel, the center frequency is required.

Measurement Bandwidth (digital format only)

Enter the width in frequency of the digital carrier to be measured.

Channel Number

The channel number can range from 1 to 999.

Label

You can enter a label up to four characters in length for each channel. This label appears next to the channel number on most screens to help you remember what programming is on that channel.

Package

You can organize channels into packages. In the edit box, you can select any package that is enabled (see the section on CHANNEL PACKAGES). When you are checking an installation, you can specify which packages the subscriber has ordered and your CLI-1750 will verify that the channels are correctly installed.

Scrambled

If the channel is scrambled, select YES here so that accurate measurements can be made.

IMPORTANT: CLI-1750 supports several scrambling formats including the following:

Horizontal Sync Suppression
Vertical Sync Suppression
Positive Trap

Audio Offset (TV and DUAL type only)

This is the offset between the video and audio carriers in MHz.

Audio Offset 2 (DUAL type only)

This is the offset between the video and second audio carriers in MHz.

When you are finished editing the channel, press the **soft** key to return to the channel list.

How to configure a digital carrier

1. From the Configure - Edit Channel Plan screen, highlight the channel that you wish to configure as digital, or select an unused channel.
2. Press **ENTER** to bring up the Configure - Edit Channel screen.
3. Highlight TYPE, choose SNGL and press ENTER.
4. Highlight Carrier and press **ENTER**. Select a digital carrier (QAM, QPSK, QPR, CAP-16) and press ENTER.

5. Highlight Frequency, press . Type in a value for Center Frequency and press ENTER.
6. Highlight Measurement BW (MHz), press . Type in a value for the bandwidth and press ENTER.
7. Highlight channel number, press . Type in a value for the channel number and press ENTER.
8. Press the return softkey.

Select Tilt Channels

From the Channel Plan screen, highlight SELECT TILT CHANNELS and press to specify carriers to measure on the TILT screen. A list of all enabled channels in the current plan appears.

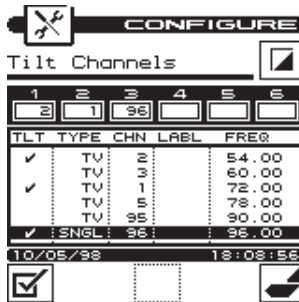

Up to six channels can be selected. To select a channel, use the up or down arrow to highlight the desired channel in the list, then press the soft key. A check mark appears in the left-hand column of the list indicating that this is now a TILT channel. Also, the channel number appears in one of the six boxes above the list.

Press the a second time to deselect the TILT channel.

Select Channel Packages

From the Configure- Channel Plan screen (page 1-29), choose CHANNEL PACKAGES. Press to bring up the Channel Packages

screen listing all available packages. These are the packages that will be available when you edit a channel. You can select from one of these packages for each channel plan.

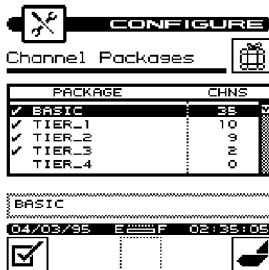

To enable a package, press the left softkey. A check mark will appear to the left. To disable, press the left softkey again. The check mark will disappear.

To edit the name, highlight the package and press ENTER. Use the Edit box to change the name. To complete, press ENTER again.

IMPORTANT: The number in the right-hand column of the package list indicates how many channels are currently using the package. When you disable a package, all channels using that package default to NONE (no package).

Copy Remote Plan

Once a plan has been created in one unit, it can be copied to another similar unit (Example: CLI-1750 to CLI-1750). Connect the two units with the cloning cable. Set the baud rates for the two units equal. On the host unit's Configure - Channel Plan screen select COPY REMOTE PLAN and press the OK softkey. The channel plan will be copied to the host.

Ingress Configuration

Sets the measurement and limit parameters for the reverse ingress scan feature. Press the  key to access the ingress options.

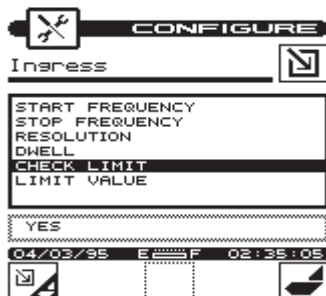

Start Frequency

Enter the frequency where you want to start the Ingress measurement. This will be the frequency at the left-hand edge of the graph on the Ingress screen.

Stop Frequency

Enter the frequency where you want to stop the Ingress measurement. This will be the frequency at the right-hand edge of the graph on the ingress screen.

Resolution

This setting determines how much detail you will see in the Ingress graph. The higher the resolution, the longer it will take to measure and display the results. There are four resolution settings; LOW, MEDIUM, HIGH, and ULTRA. You can optimize the response time depending upon how much detail you want to see.

Dwell

This is the amount of time that your CLI-1750 will spend measuring each frequency in the Ingress graph. Increasing this value will result in more accurate measurements while reducing it will improve the response time. You can optimize this as necessary for your application.

Check Limit

Select YES if you want the visual PASS/FAIL indicator to be displayed on the Ingress screen. This will allow you to easily verify whether ingress is within tolerance.

Limit Value

When the CHECK LIMIT feature is enabled, the FAIL indicator will appear whenever the Ingress measurement exceeds this value.



Transmitter Configuration

You use the keypad and display of your CLI-1750 to configure your LST-1700. The configuration data is transferred through the serial link.

IMPORTANT

In order to transfer the configuration settings to your LST-1700, you must link the serial port of your CLI-1750 to the serial port of your LST-1700 using a serial communications cable.

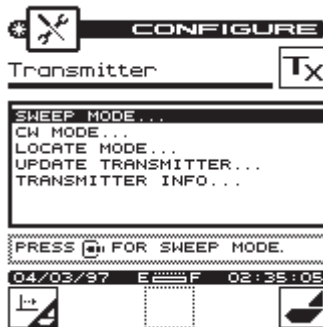



SWEEP MODE

NOTE

You will need to perform the sweep normalization process whenever you change the Sweep Mode configuration (see NORMALIZE below). Upon exiting Transmitter Configuration, your CLI-1750 will automatically prompt you if normalization is necessary.

START FREQUENCY

Enter the frequency where you want to start the frequency response measurement. This will be the frequency at the left-hand edge of the graph on the Sweep screen.

STOP FREQUENCY

Enter the frequency where you want to stop the frequency response measurement. This will be the frequency at the right-hand edge of the graph on the Sweep screen.

RESOLUTION

This setting determines how much detail you will see in the frequency response graph on the Sweep screen. The higher the resolution, the longer it will take to measure and display the results. There are four resolution settings; LOW, MEDIUM, HIGH and ULTRA. You can optimize the response time depending upon how much detail you want to see.

NORMALIZE

Normalization compensates for any variations in the sweep signal output that is transmitted by your LST-1700. This is done to maintain the utmost frequency response measurement accuracy.

1. Link the serial port of your CLI-1750 to the serial port of your LST-1700 using a serial communications cable.
2. Be sure that your LST-1700 is turned on.
3. Select the NORMALIZE... option.
4. When prompted, connect a short RF cable between the RF port on your CLI-1750 and the RF port on your LST-1700. Use as short a cable as possible – it must be no longer than 6 feet (183 cm). Press the  softkey.

5. Your CLI-1750 will now automatically normalize the frequency response measurement.

IMPORTANT

For accurate frequency response measurements, you should perform the normalization procedure every day at the beginning of your shift.

OFFSET FREQUENCY

This is an offset that is added to the sweep signal being transmitted by your LST-1700 that determines the frequencies that will be measured by your CLI-1750. An example of when this would be useful is if you wanted to transmit the sweep signal down the return path to a translator at the headend and then measure the frequency response using your CLI-1750 connected to the forward path. In this case, you would enter the translation frequency for the offset.

IMPORTANT

For normal operation, the OFFSET FREQUENCY should be set to 0.000 MHz.



CW MODE

Your LST-1700 is capable of generating a CW signal at the frequency you select. You can use this signal along with your CLI-1750 to search for leaks emanating from the drop cable that you are testing.

CW FREQUENCY

Enter the frequency where you want the LST-1700 to generate the CW signal.

IMPORTANT

If you want to use the CW signal to search for leaks, be sure the CW Frequency that you enter here matches the Leakage Measurement Frequency (see the Leakage Configuration section).

TAG MODULATION

This allows you to turn the tag feature on or off. When enabled, the tag annunciator will appear in the Leakage screen when your CLI-1750 detects the CW signal from your LST-1700.

TAG MODULATION FREQUENCY

Enter the modulation frequency to detect when searching for a tag. You can select from 3 to 25 Hz.

NOTE

Entering a value here will also change the Tag Modulation Frequency for the Leakage screen (see the Leakage Configuration section). This is because the two settings must match in order to detect the tag. Conversely, entering a value in the Leakage Configuration screen will also change the Tag Modulation Frequency here. However, it is important to realize that the LST-1700 is not updated when you change the Leakage configuration.



LOCATE MODE

RESOLUTION

This setting determines how much detail you will see in the graph on the Locate screen. The higher the resolution, the longer it will take to measure and display the results. There are four resolution settings; LOW, MEDIUM, HIGH, and ULTRA. You can optimize the response time depending upon how much detail you want to see.

NOTE

You can also change the resolution directly from the Locate screen (see RESOLUTION in the Locate section).

HARMONIC FILTER

This allows you to turn the harmonic filter on or off. To find out what harmonics are and why you may want to filter them, see HARMONIC FILTER in the Locate section.

NOTE

You can also toggle the harmonic filter on and off from the Locate screen.

CABLE COMPENSATION

Signals passing through a coaxial cable are attenuated. Higher frequency signals are attenuated more than lower frequency signals. This causes the amplitude of a reflected fault to appear lower on the Locate graph than it actually is. When you have Cable Compensation enabled, your CLI-1750 will correct for signal attenuation caused by the cable. This results in a more accurate display of fault amplitude.

CABLE ATTENUATION @ 50MHZ

This value is used by your CLI-1750 for the Cable Compensation feature described above. It can be found in the cable manufacturer's catalog or specification sheet in either dB per 100 meters or dB per 100 feet at various frequencies. Be sure to enter the value listed for a frequency of 50MHz.

IMPORTANT

Inaccurate fault amplitude readings will result if the wrong CABLE ATTENUATION value is used. Be sure to enter the value for the specific type of cable that you will be testing.



UPDATE TRANSMITTER

This option transfers the configuration settings from your CLI-1750 to your LST-1700 through the serial port.

1. Link the serial port of your CLI-1750 to the serial port of your LST-1700 using a serial communications cable.
2. Be sure that your LST-1700 is turned on.
3. Select the UPDATE TRANSMITTER... option.
4. The configuration settings will now be sent to your LST-1700.

NOTE

You will need to perform the update process whenever you change the Sweep Mode or CW Mode configuration. Upon exiting Transmitter Configuration, your CLI-1750 will automatically prompt you if updating is required.



TRANSMITTER INFO...

Select this option to view information about your LST-1700. The information is read directly from your LST-1700 through the serial port and includes the serial number, date of calibration, and software/hardware revision.

NOTE

Your LST-1700 must be connected and turned on for the information to be extracted.

MODEL CLI-1750/LST-1700

2 Using the CLI-1750/ LST-1700



INTRODUCTION

The best way to learn about the CLI-1750 is to use it. Section 2 discusses the individual measurements available with the CLI-1750. Each measurement mode discussion includes detailed descriptions on how to perform the measurement as well as operating controls and indicators.



LEAKAGE

The CLI-1750 has two sub-modes of operation that detect and measure RF leakage: the Measure mode and Find and Fix mode. The Measure mode is used to obtain the most accurate leakage measurements. The Find and Fix mode is optimized for locating the source of RF leaks. See the Searching for a Leak section (p. 2-6) for a complete description of the Find and Fix mode.

To detect and measure RF leakage, press the SHIFT +  key or choose the  icon from the NAVIGATOR screen. The LEAKAGE screen will default to the last sub-mode entered. If the CLI-1750 defaults to the Find and Fix mode, press the  soft key to enter the Measure mod.



You can read the leakage measurement numerically and on an analog meter. The units in which leakage is being measured appears directly below the meter.

NOTE

You can select the units you want to measure leakage in when you configure your CLI-1750 (see LEAKAGE UNITS in the Leakage Configuration section).

The frequency being monitored appears in the upper right-hand portion of the screen.

NOTE

You can specify the frequency of the carrier you want to monitor when you configure your unit (see MEASUREMENT FREQUENCY in the Leakage Configuration section).

ANNUNCIATORS

Annunciators appear in the area below the measurement frequency to alert you of the following conditions:

Alarm

This icon flashes when the alarm has triggered.

Tag Detected

If you are using the LST 1700 with tagger activated or the optional LT1000 Leakage Tagger, this icon appears when your CLI-1750 has detected the tag signal. This is an indication that the source of the leak originates from the plant you are testing.

MEASUREMENT PEAK

The peak leakage value is indicated on the analog meter as a solid line. It also appears numerically as shown below:



The peak value is reset periodically. You can specify how quickly you want it to reset (see PEAK HOLD RESET PERIOD in the Leakage Configuration section).

TIP

You can manually reset the peak value at any time by pressing the SHIFT +  keys.

ADJUSTING THE ALARM VOLUME

An audible sound is produced when the alarm is triggered. You can raise or lower the volume of the alarm by pressing the left and right arrows. There is a bar meter in the lower right-hand portion of the display to help you set the volume. You can mute the alarm by pressing the  key. The alarm will remain muted for a period of time. You can adjust the length of this time (see ALARM MUTE TIME-OUT in the Leakage Configuration section).

NOTE

You can adjust the threshold and specify the conditions at which the alarm is triggered when you configure your unit (see the Leakage Configuration section).

SELECTING THE ANTENNA TYPE

You can use your CLI-1750 with several different types of antennas. For accurate measurements, you should be sure that you have selected the correct type for the antenna you are currently using. Press

the  soft key to sequence through the available antenna types.

The type you have selected is represented in the upper portion of the screen by one of the following icons:



Monopole



Dipole (HD-1)



Vehicle Mount (VMA-3)



Custom

NOTE

The characteristics for each type of antenna are programmable. Be sure that you have enabled all the antenna types that you want to use.

The  soft key is only available if there is more than one enabled type. (see EDIT ANTENNA TYPES in the Leakage Configuration section).

NOTE

The antenna selection is only useful for field strength measurements. If the measurement units you have selected result in an absolute measurement, the  soft key will not be available.

ENTERING THE LEAKAGE DISTANCE

If you find a leak in an inaccessible area, you can enter the estimated distance from the leak and your CLI-1750 will calculate what the equivalent field strength would be at the reference distance. These measurements are adequate for grading leaks you have found and prioritizing your repair schedule based on leak severity. You should, however, always perform regulation compliance measurements at the required reference distance.

IMPORTANT

The most accurate and repeatable measurements are made using a dipole antenna located at the required reference distance. **This is the only method recommended by WWG for making regulation compliance measurements.**





The leakage distance appears in the upper right-hand corner of the display. To enter a different value, use the numeric keys followed by the  key.

NOTE

This feature is only useful when performing field strength measurements. If the measurement units you have selected result in an absolute measurement, the leakage distance will appear dimmed.

COMPENSATION

Compensation allows you to adjust your CLI-1750 to a calibrated leak field (see Appendix D).

Press the  soft key to adjust compensation. A new set of soft keys will appear. Use the  and  soft keys to increment and decrement the compensation value. You can find the compensation value in the upper right-hand portion of the screen directly below the measurement distance. Press the  soft key when you have finished.

TIP

You can quickly clear out the compensation value by pressing the SHIFT +  keys.

IMPORTANT

Your CLI-1750 stores a separate compensation value for each antenna type. The value automatically goes into effect when you select the antenna. If you are using a calibrated leak field, be sure to make the adjustment for each type of antenna that you want to use.

NOTE

Compensation is only useful when performing field strength measurements. If the measurement units you have selected result in an absolute measurement, the  soft key will not be available.

SEARCHING FOR A LEAK

The Find and Fix mode is the ideal mode for locating leaks. The Find and Fix mode detects and displays leakage measurements; however, it is not as accurate as the Measure mode. The leakage measurement value should only be used to locate the source of a leak. To enter the Find and Fix mode from the Measure mode, press the

 soft key.

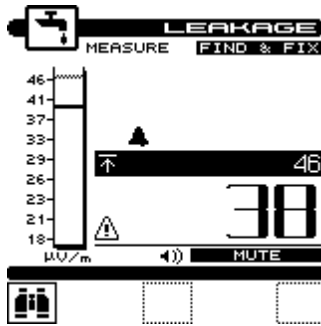



The Find and Fix mode assists the operator in locating the leakage source through numeric and audible alarm indicators. As your distance from the leakage point increases or decreases, the numeric indicator on the bottom-right of the screen changes to reflect the leakage level. The graph scale on the left side of the screen is controlled by the peak value and displays the current leakage level in relation to the peak value. When the leakage level meets or exceeds the alarm threshold, an audible alarm is triggered. The alarm rate will increase as you move closer to the leakage source.

The Find and Fix mode uses the antenna type, leakage distance, and compensation features established in the Measure mode. When you want to change the parameters of these features or obtain a more accurate measurement of the leak, press the  soft key to return to the Measure mode.

HINT

Reflections can sometimes increase or decrease received strength. Be sure to move the receiving antenna toward or away from the suspected source to obtain the maximum signal reading.

MEASUREMENT HOLD

You can freeze the leakage measurement at any time by pressing the SHIFT +  keys. Notice that the mode icon in the upper left-hand portion of the screen flashes when the measurement is on hold. Press the SHIFT +  keys again to release the hold. The measurement is not retained when another mode is selected or the CLI-1750 is shut off.

PRINTING THE SCREEN

You can print the entire screen at any time by pressing the SHIFT +  keys. A bar graph appears indicating the status of the printout.

WARNING INDICATORS

If the current measurement is inaccurate due to an out-of-range condition or a hardware failure, your CLI-1750 warns you by displaying one of the following warning indicators:

❌ **Over-range**

The leakage level is above the measurement range of the instrument.

❌ **Under-range**

The leakage level is below the measurement range of the instrument.

❌ **Error**

A hardware problem exists. If this condition persists, contact the nearest WWG Service Center.

⚠️ **Find and Fix**

Reminds the operator that the leakage measurement obtained in the Find and Fix mode is not as accurate as the Measure mode.

NOTE

The battery level is not monitored when in LEAKAGE mode.

NOTE

The Shutoff Time-out feature is disabled during LEAKAGE mode.



SWEEP

You can use your Home Wiring Test System to measure frequency response. Your LST-1700 will generate sweep signals which you can insert at the tap or ground block. You can then use your CLI-1750 to view the response of the cable and other components at the subscriber terminal(s).

IMPORTANT

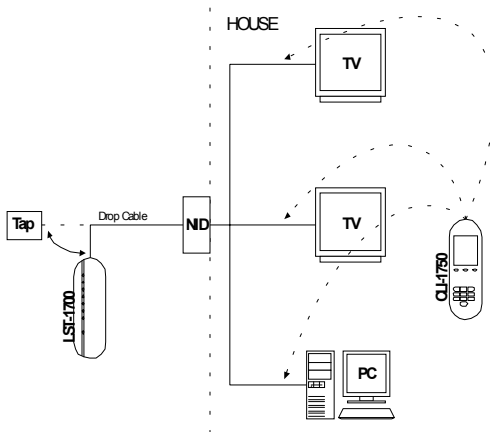

For accurate frequency response measurements, the sweep normalization procedure must be performed at the beginning of your shift. Sweep normalization is quick and easy to do (see NORMALIZE in the Transmitter Configuration section).

Place your LST-1700 at the location where you want to insert the sweep signal. You will need to leave it here while you measure the response at the other end of the cable. Try to put it in a safe place where it will not be damaged. Connect the end of the cable that you want to test to the RF port of your LST-1700.



IMPORTANT

Be sure to leave your LST-1700 turned on and in the Sweep mode.

Connect the RF port of your CLI-1750 to the end of the cable where you want to view the frequency response. Press the SHIFT +  key to select the SWEEP mode or choose the  icon from the NAVIGATOR. The SWEEP screen will appear:

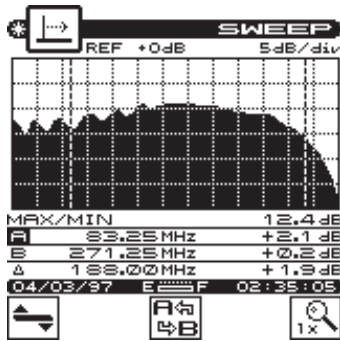

The graph displays frequency on the X-axis and amplitude on the Y-axis. Variations in the frequency response may indicate standing wave, excessive loss, roll-offs, or “suck-outs”.

NOTE

You can select the sweep start frequency, stop frequency and resolution when you configure your LST-1700 (see SWEEP MODE in the Transmitter Configuration section).





MOVING THE MARKERS

There are two vertical markers, A and B. Frequency and amplitude information for each marker is displayed beneath the graph. Press the  softkey to toggle between the two markers. The letter of the active marker (A or B) is highlighted in the marker information area beneath the graph. You can use the left or right arrows to move the active marker.





ADJUSTING THE REFERENCE LEVEL

The reference level setting is displayed above the left-hand corner of the graph. This is the amplitude at the **center** of the graph. You can adjust the reference level using the up and down arrows. When you press the SHIFT +  keys, your CLI-1750 automatically sets the optimum reference level for you.



ADJUSTING THE SCALE

The scale setting is displayed above the graph. You can adjust the scale to provide the best view of the frequency response by pressing the  softkey. A new set of softkeys appear. Use the  and  softkeys to increment and decrement the scale value. Press the  softkey when you have finished.

ZOOMING IN AND OUT

To zoom in or out from the active marker, press the  softkey. A new set of softkeys appear. Use the  softkey to zoom in and the  softkey zoom out between markers.. Press the  softkey when you have finished.

MEASUREMENT HOLD

You can freeze the sweep measurement at any time by pressing the SHIFT +  keys. The measurement is retained even if the cable is disconnected from the RF port. Notice that the mode icon in the upper left-hand portion of the screen flashes when the measurement is on hold. Press the SHIFT +  keys again to release the hold. The measurement is not retained when another mode is selected or the CLI-1750 is shut off.

PRINTING THE SCREEN

You can print the entire screen at any time by pressing the SHIFT +  keys. A bar graph appears indicating the status of the printout.

STORING A SWEEP FILE

Press the SHIFT +  keys to store the current sweep measurement into a file. A screen will appear asking you to enter a name for the file. Once stored, you will be able to recall the file at a later time and view it on the Sweep screen. You will be able to adjust the screen

settings the same as when you are viewing a "live" measurement. See the section on VIEW mode to find out how to access files that you have stored.

LOCATE

To locate faults along the length of a cable, first link the serial port of your CLI-1750 to the serial port of your LST-1700. Then connect the cable that you want to test to the RF port of your LST-1700.

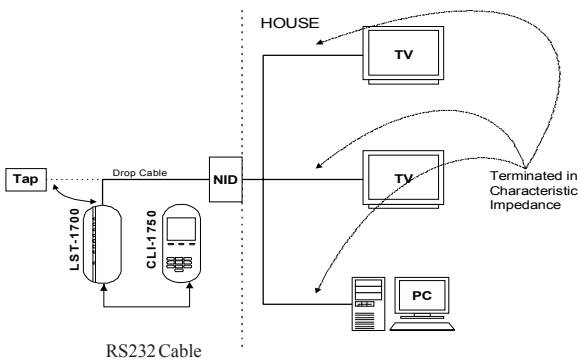

Press the SHIFT + center soft key or choose the  icon from the NAVIGATOR. The LOCATE screen will appear:

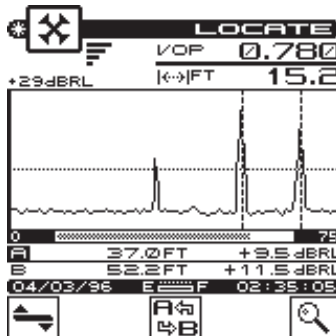

The graph presents a view of distance on the X-axis and amplitude on the Y-axis. Your LST-1700 is transmitting signals down the cable and is looking for RF energy being reflected back. Reflections occur when there is a change in impedance possibly caused by such things as cable damage, unterminated ports, or improper installation.

A reflection will appear on the graph as a peak in amplitude located at the distance where the impedance has changed. The amplitude of the reflection will indicate the severity of the impedance change. For example, a large reflection will result if the cable is broken or unterminated.

Using this graph, you can locate faults and determine how far away they are.

NOTE

You can select the units in which you want distance values to be displayed and entered when you configure your CLI-1750 (see **DISTANCE UNITS** in the Measurement Configuration section).

AMPLITUDE MARKER

The horizontal marker assists you in determining the amplitude of reflection peaks. Press the up or down arrows to adjust the amplitude marker. The amplitude at the marker is displayed numerically directly above the graph in the upper left-hand portion of the screen.

DISTANCE MARKERS

There are two vertical distance markers, A and B. You can position a distance marker over a reflection so that you can pinpoint its distance and amplitude. You can see this information for each marker directly beneath the graph. The distance between the two markers is shown above the graph in the upper right-hand portion of the screen.

Use the left or right arrows to adjust the active distance marker. The letter of the active marker (A or B) is highlighted in the distance marker information area beneath the graph. Press the  softkey to toggle between markers.

TIP





You can determine the distance between two reflections by positioning a marker over each reflection.

You can quickly move the active distance marker among reflection peaks. To place the distance marker over the next reflection, press the SHIFT + right arrow. Pressing the SHIFT + left arrow will place the distance marker over the previous reflection.





NOTE

The amplitude threshold for finding reflection peaks is determined by the position of the horizontal amplitude marker. Any reflection whose peak is above the amplitude marker will be detected.

ADJUSTING THE SCALE

You can adjust the scale to provide the best view by pressing the  softkey. A new set of softkeys appear. Use the  and  softkeys to increment and decrement the scale value. Press the  softkey when you have finished.

ZOOMING IN AND OUT

To zoom in on or out from the active marker, press the  softkey. A new set of softkeys appear. Use the  softkey to zoom in and the  softkey zoom out. Press the  softkey when you have finished.

NOTE

When zooming, your CLI-1750 attempts to achieve the best resolution for the distance range being displayed. However, the resolution will be automatically limited if there are events occurring outside the zoomed area that would cause measurement aliasing.

VELOCITY OF PROPAGATION (VOP)

The velocity of propagation is the speed at which signals travel down the length of a cable. It is determined by the dielectric material used to separate the two conductors and is usually specified by the manufacturer.

NOTE

The velocity of propagation (VOP) will vary depending on the type and manufacturer of cable.

IMPORTANT

For accurate distance measurements, the velocity of propagation (VOP) for the cable you are testing must be determined and entered by one of the following methods:

METHOD 1: ENTERING THE VOP

The velocity of propagation is typically listed in the cable manufacturer's catalog or specification sheet. If you know the type of cable you are testing and have access to the manufacturer's literature, you can simply enter the correct value into your CLI-1750. The velocity of propagation (VOP) appears in the upper right-hand corner of the display. To enter a different value, use the numeric keys followed by the  key.

NOTE

The velocity of propagation of light is represented by the number 1 (100%). Due to the laws of physics, all other signals must travel slower. When you enter a value less than 1, your CLI-1750 understands that you want to enter the velocity of propagation. It interprets values greater than 1 as entering the distance between markers.

METHOD 2: ENTERING THE LENGTH OF A SAMPLE CABLE

If you do not have access to the manufacturer's velocity of propagation specification or if you suspect that it is inaccurate for the particular cable you are testing, you can use a sample of known good cable (with no faults) to deduce the correct velocity of propagation.

NOTE

The sample cable must be of the same type that you will be testing. The longer the length of the sample, the more accurate the results will be. However, because you will need to physically measure the length of the sample precisely, there is a practical limit to how long it can be.

First, measure the length of the sample cable from end to end. Then connect one end of the sample cable to the RF port of your LST-1700 and **leave the other end unterminated**. A peak will appear on the Locate graph at the distance where the RF energy is being reflected by the unterminated end of the cable. Place one of the distance markers over this peak. Move the other marker to a distance of zero (left most side of the graph). The distance between markers appears in the upper right-hand corner of the display. Now enter the actual length of the sample cable that you previously measured. Use the numeric keys followed by the  key. Your CLI-1750 will calculate the correct velocity of propagation based on the length that you enter.

RESOLUTION

Resolution affects how much detail you see on the graph. Like most good things, resolution comes at a cost – the higher the resolution, the longer it takes to measure and display the results. Your CLI-1750 allows you to adjust the resolution so that you can optimize the response time depending upon how much detail you want to see.

There are four resolution settings; LOW, MEDIUM, HIGH, and ULTRA. You can increase the resolution by pressing the SHIFT + up arrow or decrease it by pressing the SHIFT + down arrow. You can determine what the current setting is by looking at the resolution indicator in the upper left-hand portion of the display directly below the title bar:

 Low



 Medium

 High

 Ultra

HARMONIC FILTER

Due to the non-sinusoidal nature of the RF energy being reflected back, harmonics can sometimes occur on the Locate graph. They are most likely when there are large faults (e.g., opens or shorts) at close distances (less than 30 meters or 100 feet). Harmonics appear as false reflections and do not represent actual faults in the cable. The Harmonic Filter mathematically removes these unwanted false reflections.

To toggle the Harmonic Filter on and off, press the SHIFT +  keys. When the Harmonic Filter is on, the  indicator will appear in the upper portion of the screen.



NOTE

You will probably want to leave the Harmonic Filter on most of the time to eliminate false reflections. However, you should use caution when using the filter in situations where there are actual faults occurring at multiples of one another. For example, if you are testing two cables of the same length that are connected together, part of the reflection from the connector between the cables will be removed by the filter because it occurs at the same distance as a harmonic.

IMPORTANT

It is possible that the Harmonic Filter may prevent faults that occur at large distances and/or low amplitudes from appearing on the graph. You should turn the Harmonic Filter off when there are no close or large faults so that you do not miss any actual faults. Harmonics are minimal in these situations but be mindful that they may exist on the Locate graph when the filter is off.

MEASUREMENT HOLD

You can freeze the measurement at any time by pressing the SHIFT +  keys. Notice that the mode icon in the upper left-hand portion of the screen flashes when the measurement is on hold. Press the SHIFT +  keys again to release the hold. The measurement is not retained when another mode is selected or the CLI-1750 is shut off.

PRINTING THE SCREEN

You can print the entire screen at any time by pressing the SHIFT +  keys. A bar graph appears indicating the status of the printout.



STORING A LOCATE FILE

Press the SHIFT +  keys to store the current measurement into a file. A screen will appear asking you to enter a name for the file. Once stored, you will be able to recall the file at a later time and view it on the Locate screen. See the section on VIEW mode to find out how to access files that you have stored.





INSTALLATION

The INSTALLATION mode allows you to easily check the channels that you have just installed and verify that they are within limits. If you have configured channel packages, you can tell your CLI-1750 which packages the subscriber has ordered and it will display only those channels.



Press the  key to select the INSTALLATION mode or choose the  icon from the NAVIGATOR. Your CLI-1750 will begin measuring all the enabled channels in the plan. A bar graph indicates the percentage of channels measured. When your CLI-1750 has finished, you can view the results and verify that all channels are within limits.

SELECTING CHANNEL PACKAGES

If you have configured channel packages (See MEASUREMENT AND CHANNEL CONFIGURE MODE), a list of available packages will appear. From this list, you can select the packages that the subscriber has ordered. The number to the right of the package name tells you how many channels are included in each package. Use the up or down arrows to highlight a package and then press the  soft key to select it. A check mark appears in the left-hand column of the list indicating that the package is selected. If the highlighted package is already selected, pressing the  soft key disables it.

TIP

Select “ALL CHANNELS” if you want to include **all** the enabled channels in the plan.



Press the  soft key or  when you have finished. Now your CLI-1750 will only evaluate the channels from the packages that you have selected.

TIP

You can return to this screen at any time to change your package selection by pressing the  soft key.

SELECTING THE TEST POINT

The next thing you should do is tell your CLI-1750 at which test point you are located. This determines which set of limits are used. Press the  soft key to sequence through the available test points. The test point that you have selected is represented in the upper portion of the screen by one of the following icons:

-  Subscriber Drop
-  Ground Block
-  Tap
-  User Defined

NOTE

Be sure that you have enabled all of the test points that you are interested in using. The  soft key is only available if there is more than one enabled test point. (see EDIT TEST POINTS).

IMPORTANT

Only the limits that are enabled in the selected test point are checked (see EDIT TEST POINTS).

INSTALLATION RESULTS SUMMARY

This is the overall limit check summary for all channels in the packages that you have selected. You may have to scroll down the list to see all the limits results.

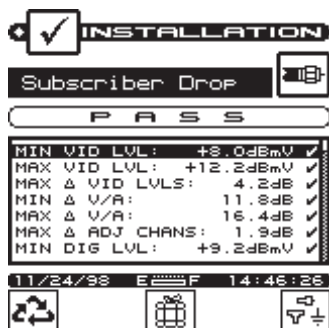

To quickly determine the status of the overall limit check, look at the PASS/FAIL indicator located in the upper portion of the screen. This indicates FAIL if any channel is not within the required limits. For each limit, the worst case actual value is displayed along with a pass/fail status.



NOTE

Only the limits that are enabled in the selected test point appear on this screen. If there are no enabled test points, this screen will not be available. You can however, view the CHANNEL LIST and CHANNEL MEASUREMENT screens described below.

THE CHANNEL LIST

Press the  soft key or  to sequence to the channel list screen.

TIP

In addition to using the  and  keys, you can also use the left and right arrows to sequence through the results screens.

The channel list provides essential information about each channel.

✓ INSTALLATION				
Subscriber Drop				
P A S S				
CHN	LABEL	dBmV	PKG	P/F
19	SHOW	-17.7	TIER_2	✗
21	NICK	+0.1	BASIC	✓
22	TNN	+4.5	BASIC	✗
23	USA	+1.4	BASIC	✓
24	ESPN	+0.8	BASIC	✓
25	MTV	+2.6	BASIC	✓

E F

In the list you will find the channel number in the first column followed by the label. The level of the video carrier is in the next column. The package in which the channel is contained is displayed in the fourth column. Finally, the overall limits pass/fail result for the channel is found in the last column.

THE PASS/FAIL INDICATOR

Use the PASS/FAIL indicator located directly above the channel list to quickly determine whether the highlighted channel has passed the limits check. If the channel failed, you can identify the reason(s) for the failure by looking at the symbols that appear in this indicator.



Adjacent Channel Failures

- lower adjacent channel level
- upper adjacent channel level
- both upper and lower adjacent channel levels



Video Level Failures

- video level too high
- video level too low

DVA Failures

- DVA too high
- DVA too low

CHANNEL MEASUREMENT

Press the  soft key or  to sequence to the channel measurement screen.



This screen displays video and audio carrier level measurements along with the DVA for the selected channel. Use the up or down arrows to select the previous or next channel in the list.

PRINTING AN INSTALLATION REPORT

Press the SHIFT +  keys to print a comprehensive report of the installation results. A bar graph appears indicating the status of the printout. The report lists level measurements for all the channels that you installed and indicates out-of-limit conditions with an overall PASS/FAIL conclusion. Space is provided for you to fill in subscriber information. You can attach the report to your work order or file it for future reference.



STORING INSTALLATION RESULTS

Press the SHIFT +  keys to store the results of the installation check into a file. A screen will appear asking you to enter a name for the file. See the section on VIEW mode to find out how to access files that you have stored.

TIP

The results from the most recent installation check are stored automatically. If you have selected another mode and wish to return to viewing the installation results you can do so without having to repeat the measurement process. Simply press the SHIFT +  keys and the results of the most recent installation check will appear.

LEVEL

Press the  key to select LEVEL mode or choose the  icon from the NAVIGATOR. Here you can measure the signal level of a specific channel or frequency. The level is indicated both numerically and on an analog meter.

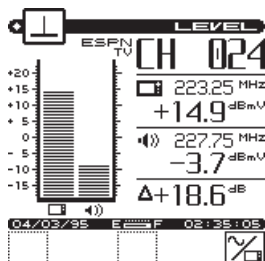

ADJUSTING THE REFERENCE LEVEL

You can adjust the reference level setting of the analog bar meter using the up and down arrows. When you press the SHIFT +  keys, your CLI-1750 automatically sets the optimum reference level for you.

TUNING BY CHANNEL

When you are tuned to a channel, both the video and audio carriers of the channel are measured and displayed simultaneously. The difference between the video and audio carriers (DVA) is also shown. The channel number, type and label for the channel that you are currently tuned to appear in the upper right-hand portion of the screen. You can use the left or right arrows to tune to the previous or next enabled channel in the plan. You can also use the numeric entry keys to tune directly to the desired channel. Press the  soft key to tune by frequency.

TUNING BY FREQUENCY

The  soft key toggles between frequency and channel tuning. When you choose frequency tuning, your CLI-1750 tunes to the video carrier frequency of the selected channel.

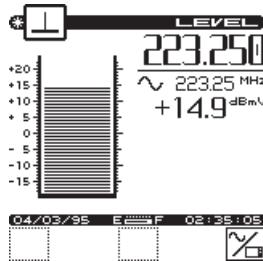

Use the left and right arrows to tune your CLI-1750. The frequency increments or decrements by the step size that you have specified in the Measurements configuration (see FREQUENCY TUNING STEP SIZE). You can also use the numeric entry keys to tune directly to the frequency desired.

MEASURING DIGITAL CARRIERS (1750DIG option only)

If your CLI-1750 was ordered with the 1750DIG option, you can measure the signal level of digitally modulated carriers. You will need to define a single (SNGL) type channel and specify the carrier modulation format, the center frequency and measurement bandwidth for each digital carrier that you want to measure (see EDIT CHANNEL PLAN in the Channel Plan Configuration section).

IMPORTANT

Digital signal level measurements can only be performed on carriers that are in a state of continuous (i.e., non-burst) transmission.

When you have selected a single type channel with digital carrier modulation, the measurement bandwidth and carrier modulation format are displayed beneath the numeric level value on the right-hand side of the screen.

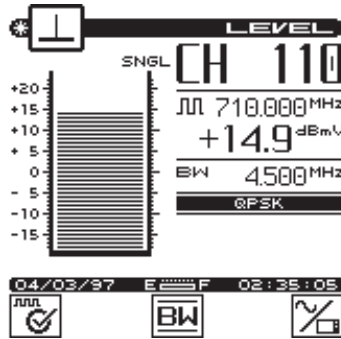

You can change the Measurement Bandwidth setting for the channel that you are currently measuring by pressing the **BW** soft key. Enter the desired value in the edit box that appears.

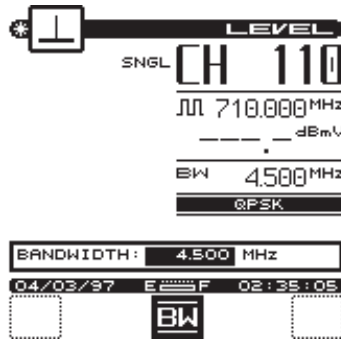

Your CLI-1750 is equipped with digiCheckTM technology for the optimum in digital measurement precision. Press the **✓** soft key for maximum accuracy.

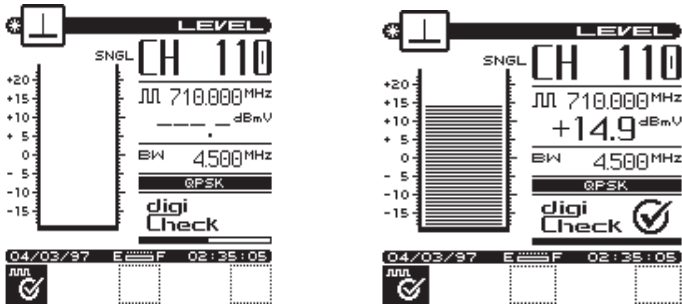

You can watch the measurement progress by looking at the status bar in the lower right-hand portion of the display. Press the  soft key to return to the Quick digital measurement mode.

Why Two Measurement Techniques?

Your CLI1750 provides two alternate techniques for measuring the power of a digital carrier: Quick mode and digiCheck™.



The Quick measurement mode estimates the power over the entire channel. It multiplies the level at the center frequency of the carrier by a scaling factor (determined from the bandwidth that you have entered). The advantage of the Quick measurement mode is that it updates rapidly.

The digiCheck™ measurement provides greater precision, particularly when there is an irregular distribution of power over the channel bandwidth. It takes measurements throughout the selected bandwidth, summing the power across the entire channel. Use digiCheck™ when you want maximum accuracy.

NOTE

The digiCheck™ measurement is available only when you are using the LEVEL mode. All other modes (e.g., SCAN, AUTO TEST, etc.) perform the Quick measurement only.

MEASUREMENT HOLD

You can freeze the level measurement at any time by pressing the SHIFT +  keys. The measurement is retained even if the cable is disconnected from the input port. Notice that the mode icon in the upper left-hand portion of the screen flashes when the measurement is on hold. Press the SHIFT +  keys again to release the hold. The hold is also released when you tune to a different channel or frequency. The measurement is not retained when another mode is selected or the CLI-1750 is shut off.

PRINTING THE SCREEN

You can print the entire screen at any time by pressing the SHIFT +  keys. A bar graph appears indicating the status of the printout.

TIP

If you are using your CLI-1750 at a location where it is not convenient to connect to a printer (such as on a pole), you can put the measurement on hold until you are able to access the printer.

WARNING INDICATORS

If the current measurement is inaccurate due to an out-of-range condition or a hardware failure, your CLI-1750 warns you by dimming the numeric measurement value and displaying one of the following warning indicators:

Over-range

The signal level is above the measurement range of the instrument.

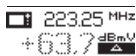

The image shows a digital display with a dimmed numeric value. The top line shows a square icon with a vertical bar, followed by "223.25 MHz". The second line shows a dimmed "+63.7" followed by "dBmV" and a small icon of a camera.

Under-range

The signal level is below the measurement range of the instrument.





The image shows a digital display with a dimmed numeric value. The top line shows a square icon with a vertical bar, followed by "223.25 MHz". The second line shows a dimmed "-43.1" followed by "dBmV" and a small icon of a camera.

Error

A hardware problem exists. If this condition persists, contact your nearest Wavetek Service Center.



FULL SCAN

Press the  key to select the FULL SCAN mode or choose the  icon from the NAVIGATOR. A spectral graph of all the carriers in the channel plan appears.

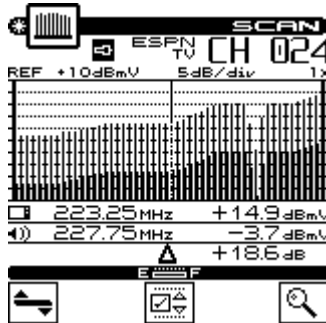

MOVING THE MARKER





A vertical marker appears over the currently selected channel. The channel number, type and label appear in the upper right-hand portion of the screen. The frequency and level of the video and audio carriers for the selected channel can be seen directly beneath the graph. You can use the left or right arrows to select the previous or next channel. You can also use the numeric entry keys to tune directly to the desired channel.

ADJUSTING THE REFERENCE LEVEL





The reference level setting is displayed above the graph. This is the level at the very top line. You can adjust the reference level using the

up and down arrows. When you press the SHIFT +  keys, your CLI-1750 automatically sets the optimum reference level for you.

ADJUSTING THE SCALE

The scale setting is displayed above the graph. You can adjust the scale to provide the best view of the carrier levels by pressing the  soft key. A new set of soft keys appear. Use the  and  soft keys to increment and decrement the scale value. Press the  soft key when you have finished.

ZOOMING IN AND OUT

To zoom in on or out from the channel selected by the marker, press the  soft key. A new set of soft keys appear. Use the  soft key to zoom in and the  soft key to zoom out. The magnification factor is displayed above the graph. Press the  soft key when you have finished.



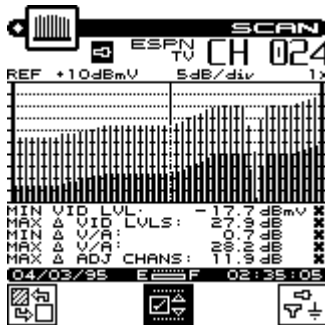

CHECKING LIMITS

You can verify that the carrier levels are within limits. First, you need to tell your CLI-1750 which test point you are at. This determines which set of limits are used.

Press the  soft key to access the limits submenu. A new set of soft keys appear.



Press the  soft key to sequence through the available test points. The test point that you have selected is represented in the upper portion of the screen by one of the following icons:

-  Subscriber Drop
-  Ground Block
-  Tap
-  User Defined

NOTE

Be sure that you have enabled all of the test points that you are interested in using. The  soft key is only available if there is more than one enabled test point. (see EDIT TEST POINTS).

When you have selected the limits submenu, the marker information below the graph is replaced by the overall limit check summary for channels **currently being displayed on the graph**. For each limit, the worst case actual value is displayed along with a pass/fail status. The results are updated upon the completion of each scan. When the cursor is on an analog channel, the analog limits are displayed. When the cursor is on a digital channel, the digital limits are displayed as shown below.

Cursor on Analog Channel

```
MIN VID LVL: -17.7 dBmV **
MAX Δ VID LVL: 27.3 dB **
MIN Δ U/A: 28.2 dB **
MAX Δ U/A: 28.2 dB **
MAX Δ ADJ CHANS: 11.9 dB **
```

Cursor on Digital Channel

```
MIN DIG LVL: -4.3 dBmV
MAX DIG LVL: +8.4 dBmV
```

IMPORTANT



The limit check results apply only to the channels currently being displayed on the graph — not the entire channel plan.

NOTE

Only the limits that are enabled in the selected test point appear on this screen.

Your CLI-1750 can indicate the minimum and maximum carrier level limits on the graph. When the cursor is on an analog channel, video min and max are used. When the cursor is on a digital channel, the digital min and max are used. The min and max hash lines will change as the cursor moves. The out-of-limit portions appears as diagonal “hash” areas. You can toggle the hash lines on and off by pressing the  key.







NOTE

The limit check results are updated with each scan. They are also updated immediately when you press the  or  soft keys.

When you are finished viewing the overall limit results, press the  soft key to return to the main menu.

CHECKING LIMITS ON AN INDIVIDUAL CHANNEL



Indicators appear in the marker information area when a channel is outside the limits of the currently selected test point.

	223.25 MHz		+14.9 dBmV
	227.75 MHz		-3.7 dBmV
	CHAN		+18.6 dB



Up or down arrows to the left of the video level and DVA numeric measurement tell you when the limits have been exceeded.

-  measurement too high
-  measurement too low

When an adjacent channel error occurs, one of the following indicators will appear in the lower left-hand area of the marker information area:

-  lower adjacent channel level
-  upper adjacent channel level
-  both upper and lower adjacent channel levels

MEASUREMENT HOLD

You can freeze the scan measurement at any time by pressing the SHIFT +  keys. The measurement is retained even if the cable is disconnected from the input port. Notice that the mode icon in the upper left-hand portion of the screen flashes when the measurement is on hold. Press the SHIFT +  keys again to release the hold. The measurement is not retained when another mode is selected or the CLI-1750 is shut off.

PRINTING THE SCREEN

You can print the entire screen at any time by pressing the SHIFT +  keys. A bar graph appears indicating the status of the printout.

STORING A SCAN FILE

Press the SHIFT +  keys to store the current scan measurement into a file. A screen will appear asking you to enter a name for the file. Once stored, you will be able to recall the file at a later time and view it on the Scan screen. You will be able to adjust the screen settings the same as when you are viewing a “live” measurement. See the section on VIEW mode to find out how to access files that you have stored.

WARNING INDICATORS

If the current measurement is inaccurate due to an out-of-range condition or a hardware failure, your CLI-1750 warns you by displaying one of the following warning indicators to the left of the numeric level measurement in the marker information area:

Over-range

The signal level is above the measurement range of the instrument.

Under-range

The signal level is below the measurement range of the instrument.

Error

A hardware problem exists. If this condition persists, please contact your nearest Wavetek Service Center



TILT

TILT mode simplifies the process of balancing an amplifier. TILT mode can only be accessed by choosing the  icon from the NAVIGATOR. A spectral graph of the TILT carriers appears.

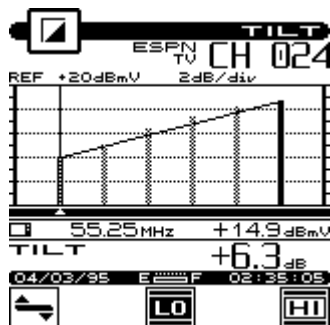

IMPORTANT

You can choose which carriers appear on this screen when you configure your channel plan (see SELECT TILT CHANNELS).

MOVING THE MARKER

You can view up to six carriers. A vertical marker appears over the currently selected carrier. The channel number, type and label appear in the upper right-hand portion of the screen. The frequency and level of the selected carrier can be seen directly beneath the graph. You can use the left or right arrows to select the previous or next carrier.





SELECTING THE LOW AND HIGH CARRIERS

Notice that the bars representing the low and high pilots are solid and all others are dim. You can select which carriers are used for the tilt measurement. To select the low pilot carrier, move the cursor to the desired carrier and press the **LO** soft key. To select the high pilot carrier, move the cursor to the desired carrier and press the **HI** soft key. The tilt measurement is calculated from the low and high pilot carriers that you have selected.



ADJUSTING THE REFERENCE LEVEL

The reference level setting is displayed above the graph. This is the level at the very top line. You can adjust the reference level using the up and down arrows. When you press the SHIFT + **↕** keys, your CLI-1750 automatically sets the optimum reference level for you.

ADJUSTING THE SCALE

The scale setting is displayed above the graph. You can adjust the scale to provide the best view of the carrier levels by pressing the  soft key. A new set of soft keys appears. Use the  and  soft keys to increment and decrement the scale value. Press the  soft key when you have finished.

MEASUREMENT HOLD

You can freeze the tilt measurement at any time by pressing the SHIFT +  keys. The measurement is retained even if the cable is disconnected from the input port. Notice that the mode icon in the upper left-hand portion of the screen flashes when the measurement is on hold. Press the SHIFT +  keys again to release the hold. The measurement is not retained when another mode is selected or the CLI-1750 is shut off.

PRINTING THE SCREEN

You can print the entire screen at any time by pressing the SHIFT +  keys. A bar graph appears indicating the status of the printout.

STORING A TILT FILE

Press the SHIFT +  keys to store the current tilt measurement into a file. A screen will appear asking you to enter a name for the file. Once stored, you will be able to recall the file at a later time and view it on the Tilt screen. You will be able to adjust the screen settings the same as when you are viewing a “live” measurement. See the section on VIEW mode to find out how to access files that you have stored.



SCAN

The CLI-1750 includes an additional SCAN mode that can display up to six video carriers. You can access this mode by choosing the  icon from the NAVIGATOR.

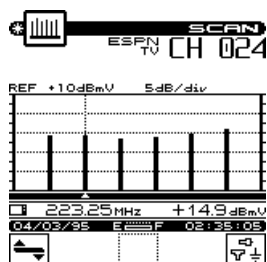

NOTE

The channels that appear on this screen are the same ones that you selected when you configured your tilt channels. (see SELECT TILT CHANNELS).





MOVING THE MARKER

A vertical marker appears over the currently selected carrier. The channel number, type and label appear in the upper right-hand portion of the screen. The frequency and level of the selected carrier can be seen directly beneath the graph. You can use the left or right arrows to select the previous or next carrier.

ADJUSTING THE REFERENCE LEVEL

The reference level setting is displayed above the graph. This is the level at the very top line. You can adjust the reference level using the up and down arrows. When you press the SHIFT +  keys, your CLI-1750 automatically sets the optimum reference level for you.





ADJUSTING THE SCALE

The scale setting is displayed above the graph. You can adjust the scale to provide the best view of the carrier levels by pressing the  soft key. A new set of soft keys appears. Use the  and  soft keys to increment and decrement the scale value. Press the  soft key when you have finished.

CHECKING LIMITS

You can verify that the carrier levels are within limits. First, you need to tell your CLI-1750 which test point you are at.

This determines which set of limits are used. Press the  soft key to sequence through the available test points. The test point that you have selected is represented in the upper portion of the screen by one of the following icons:

-  Subscriber Drop
-  Ground Block
-  Tap
-  User Defined

NOTE

Be sure that you have enabled all of the test points that you are interested in using. The  soft key is only available if there is more than one enabled test point. (see EDIT TEST POINTS).

When you have selected the proper test point, your CLI-1750 shows the minimum and maximum carrier level limits for that test point on the graph. When the cursor is on an analog channel, video min and max are used. When the cursor is on a digital channel, the digital min and max are used. The min and max hash lines will change as the cursor moves. The out-of-limit portions appears as diagonal “hash” areas. You can toggle the hash lines on and off by pressing the  key.

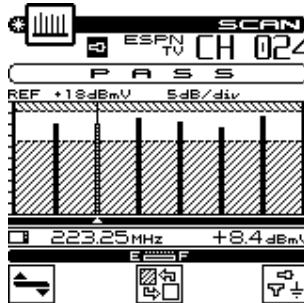

You can quickly check to see if all SCAN carriers are within limits by looking at the PASS/FAIL indicator above the graph.

MEASUREMENT HOLD

You can freeze the scan measurement at any time by pressing the SHIFT +  keys. The measurement is retained even if the cable is disconnected from the input port. Notice that the mode icon in the upper left-hand portion of the screen flashes when the

measurement is on hold. Press the SHIFT +  keys again to release the hold. The measurement is not retained when another mode is selected or the CLI-1750 is shut off.

PRINTING THE SCREEN

You can print the entire screen at any time by pressing the SHIFT +  keys. A bar graph appears indicating the status of the printout.

STORING A SCAN FILE

Press the SHIFT +  keys to store the current scan measurement into a file. A screen will appear asking you to enter a name for the file. Once stored, you will be able to recall the file at a later time and view it on the Scan screen. You will be able to adjust the screen settings the same as when you are viewing a “live” measurement. See the section on VIEW mode to find out how to access files that you have stored.



AUTO TEST

IMPORTANT

Before performing Scheduled Auto Tests, make sure that the unit's Shutoff Timeout is NOT programmed for "always on". Program the Shutoff Timeout for 1, 3 or 5 minutes (See Global Configuration).

Your CLI-1750 is capable of performing unattended, automated level measurement sequences. The sequences can be programmed to repeat over a period of time. Measurement data is stored into a file that can be viewed, printed or uploaded to StealthWare. See the section on VIEW mode to find out how to access files from Auto Tests that you have performed.

IMPORTANT



When performing an Auto Test, only the channels enabled in the currently selected channel plan are measured.

CONFIGURING AN AUTO TEST

Choose the  icon from the NAVIGATOR to configure an automated test sequence. Your CLI-1750 will guide you step by step.



Choose Location

If desired, you can log information about the location at which you are performing the test. The information will be stored in the Auto Test file along with the measurement data. It will be available when viewing and printing the Auto Test results. This first screen presents you with a list of available locations. To create a new location, press the  soft key. Press  soft key to delete the location highlighted in the list. Press the  soft key to select the highlighted location and continue to the next step.

TIP



If you are not interested in logging the information, select NONE from the list. Your CLI-1750 will present you with only the steps required to configure the test.

TIP

You can rename the location highlighted in the directory by pressing the SHIFT +  keys. A screen will appear asking you to enter a new name.



New/Edit Location

This screen is where you enter the information for a new or existing location. Use the up and down arrows to select the item to be edited. The items that appear in the list depend on the type of location you have selected. If you regularly perform tests at this location, you can save it for future use so that you only need to enter the information once. To do this, press the  soft key and enter a name for the location. When you are done editing, press  to continue configuring the Auto Test.

NOTE

Your CLI-1750 will remind you when you have not stored the location. You should only do this, however, if you think you will return for another test.



Choose Probe Point

Some location types have multiple points at which you can make test measurements. If you have selected such a type, this screen will appear. Use the up and down arrows to choose the appropriate probe point from the list and then press the **OK** soft key.



Measure Voltage

You can log voltage measurements that you make using your multimeter. These will appear when viewing or printing the results of the Auto Test. When you have finished entering the measurements, press the **OK** soft key.



Compensation

Compensation is added directly to the signal level measurements. You can use this to compensate for losses associated with probe points found on certain amplifiers. The default is the Probe Compensation value specified in Configure. Enter a different value if necessary. Press the **OK** soft key to continue.



Results File Name

Enter the name you want to use for the results file that is created. Your CLI-1750 will let you know if there is already a results file with the name that you enter. If desired, you can overwrite an existing file of the same name. When you are ready for the next step, press the **OK** soft key.



Type of Test

Tests can be executed immediately or scheduled over a period of time. Use the up and down arrows to select the type of test you want and then press the **OK** soft key.



Set Schedule

This screen will appear only if you have selected a scheduled test. The default schedule will perform four intervals

over a twenty-four hour period beginning at the present time and date. If you require a different schedule, use the up and down arrows to edit the schedule and then press the  soft key.



Temperature

The ambient temperature at which the test is performed is recorded. Your CLI-1750 contains an internal temperature sensor for this purpose. If you prefer to use your own thermometer, you can manually enter the temperature here.

IMPORTANT

For scheduled tests, the manual temperature entry is used for the first interval only. Subsequent intervals will record the temperature as measured by the internal sensor. For accurate measurements, your CLI-1750 reads the internal temperature sensor immediately upon power-up.

When you are ready to begin the test, press the  soft key.

PERFORMING AN AUTO TEST

The following screen appears when your CLI-1750 is performing Auto Test measurements:

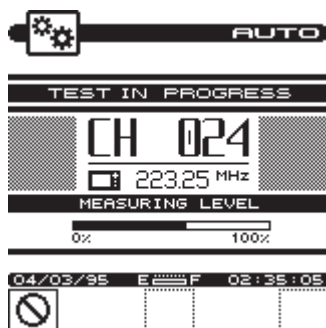

The number, type and carrier frequency of the channel currently being measured is displayed. The bar graph indicates the percentage of channels measured.

If you are performing a scheduled test, the time remaining until the next interval will appear upon completion of the measurements.

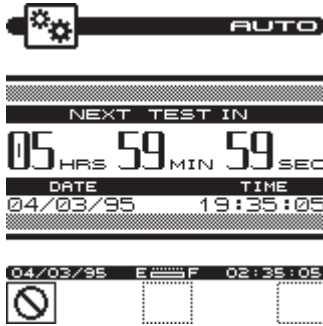

IMPORTANT

To conserve battery life, your CLI-1750 will automatically shut itself off between scheduled intervals.

When the auto test is complete, your CLI-1750 will display a list of Auto Test files that are available for viewing and printing.

NOTE

See the section on VIEW mode to find out how to access files from Auto Tests that you have performed.

CANCELING AN AUTO TEST

While performing an Auto Test, you will not be able to select other modes without first canceling the test in progress. Doing this will result in an incomplete test — you will not be able to resume the previously configured test.

Press the  soft key to cancel the Auto Test. Your CLI-1750 will display a warning message and ask you to confirm your request.



VIEW

To access measurement files that you have stored in your CLI-1750, choose the  icon from the NAVIGATOR. Files are categorized into Installations, Scans (including Tilt measurements), Auto Tests, Ingress, Sweep and Locate.





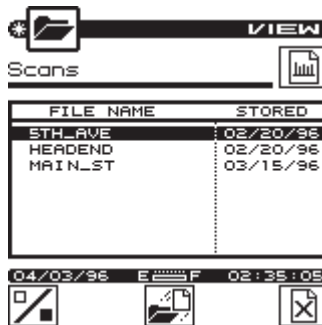

Use the up and down arrows to select the type of file that you want to view from the main menu and then press the  key.

THE FILE DIRECTORY



Upon selecting the file category from the VIEW main menu, you are presented with a directory of existing files. For example, below is the directory of Scan files:



To view a file, use the up and down arrows to highlight the name of the file that you want to view and then press either the  soft key or the  key.

To delete the highlighted file, press the  soft key. You can delete more than one file at a time by selecting multiple files using the  soft key. Each press of this soft key alternately selects and deselects the file that you have highlighted. An indicator appears in the left-hand column to show that you have selected the file. Select all the files that you want to delete before pressing the  soft key.

TIP

You can print Installation and Auto Test files from the directory. To print an Installation or Auto Test file, use the up and down arrows to highlight the name of the file that you want to print and then press SHIFT + . You can print multiple file by first selecting them using the  soft key and then press SHIFT + . If a scheduled type Auto Test is highlighted, all intervals contained in the file will be printed. You must view Scan files in order to print them.

TIP

You can rename the file highlighted in the directory by pressing the SHIFT +  keys. A screen will appear asking you to enter a new name.

VIEWING INSTALLATION FILES

You view Installation files using the Installation results screens described earlier in this manual. When viewing a file, you can print a comprehensive report of the installation results by pressing the SHIFT +  keys.

NOTE

When viewing an Installation file, the date and time that the file was stored appears in the status bar and the file name appears at the top of the screen above the title bar.

TIP

You can resave an Installation file by pressing the SHIFT +  keys. This allows you to change the name of the file.

VIEWING SCAN FILES

There are three types of scans that you can store and view — full scans, six-channel scans and tilt measurements. The type of scan depends on which screen you are in when you store the file. Once the scan is stored, you cannot change its type.

TIP

You can tell what type of scan you have selected in the directory without having to view it. Just look at the icon in the upper right-hand portion of the screen directly below the title bar:



FULL SCAN



SIX-CHANNEL SCAN



TILT MEASUREMENT

You view Scan files using the same screen in which the file was stored. For example, the following screen is used to view full scan files:

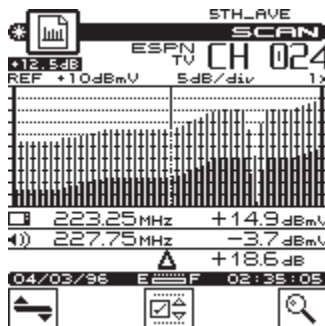

IMPORTANT

When viewing a Scan file, you can adjust the screen settings the same as when you are viewing a “live” measurement. These settings are described earlier in this manual.

NOTE

You can print the entire screen at any time by pressing the SHIFT +  keys. A bar graph appears indicating the status of the printout.

NOTE

When viewing a Scan file, the date and time that the file was stored appears in the status bar and the file name appears at the top of the screen above the title bar.

TIP



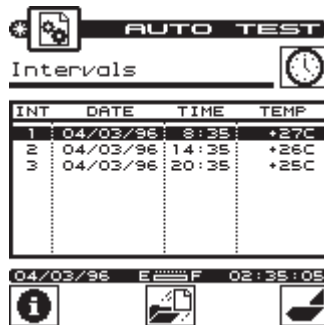

You can resave a Scan file by pressing the SHIFT +  keys. This allows you to change the name of the file and/or save any changes you have made to the screen settings.

VIEWING AUTO TEST FILES

Upon selecting the desired Auto Test file, you are presented with a list of intervals that are contained within the file. The list includes the interval number, date, time and temperature when the interval was recorded.



The screenshot shows a handheld device screen with the following layout:

- Top status bar:  **AUTO TEST**
- Sub-header: Intervals 
- Table with 4 columns: INT, DATE, TIME, TEMP
- Bottom status bar:  04/03/96 E  F 02:35:05 

INT	DATE	TIME	TEMP
1	04/03/96	8:35	+27C
2	04/03/96	14:35	+26C
3	04/03/96	20:35	+25C



NOTE

Immediate type Auto Tests consist of only a single interval.

Press the  soft key to view information about the Auto Test file. This displays the information that was logged when you configured the test. The items presented depend upon the location type that you selected.

NOTE

To print a 24-hour format report, use the up and down arrows to highlight the first interval that you want included in the report and then press SHIFT + . The report will include the highlighted interval plus the following three for a total of (up to) four intervals.

To view the measurement data from an interval, use the up and down arrows to highlight the desired interval then press either the  soft key or the  key. There are three screens in which the data is presented:

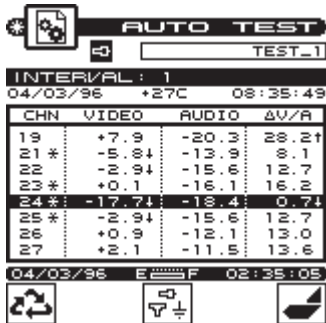

AUTO TEST
TEST_1

INTERVAL: 1
04/03/96 +27C 08:35:49

CHN	VIDEO	AUDIO	ΔV/A
19	+7.9	-20.3	28.2†
21*	-5.8‡	-13.9	8.1
22	-2.9‡	-15.6	12.7
23*	+0.1	-16.1	16.2
24*	-17.7‡	-18.4	0.7‡
25*	-2.9‡	-15.6	12.7
26	+0.9	-12.1	13.0
27	+2.1	-11.5	13.6

04/03/96 E F 02:35:03



AUTO TEST
TEST_1

INTERVAL: 1
04/03/96 +27C 08:35:49

← CHAN → VID ▼ DVA ▼

ESPN TV CH 024

223.25MHz ▼ -17.7 dBmV

227.75MHz ▼ -18.4 dBmV

▲ ▼+ 0.7 dB

04/03/96 E F 02:35:03

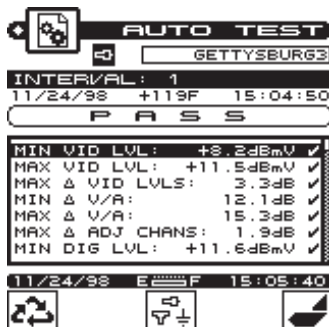

AUTO TEST
GETTYSBURG3

INTERVAL: 1
11/24/98 +119F 15:04:50



P A S S



MIN VID LVL:	+8.2dBmV	✓
MAX VID LVL:	+11.5dBmV	✓
MAX Δ VID LVLS:	3.3dB	✓
MIN Δ V/A:	12.1dB	✓
MAX Δ V/A:	15.3dB	✓
MAX Δ ADJ CHANS:	1.9dB	✓
MIN DIG LVL:	+11.6dBmV	✓

11/24/98 E F 15:05:40

The first screen that will appear is a tabular list that includes the video and audio carrier levels along with the delta V/A for each channel. Use the up and down arrows to scroll through the list. Indicators appear within the list to flag out-of-limit conditions. The following table relates each indicator with its meaning:

- * adjacent channel limit violation (does not apply to digital limits)
- ↑ over limit violation
- ↓ under limit violation
- > over range measurement error
- < under range measurement error
- E unlocked measurement error

To view the data for the channel highlighted in the list press the  soft key or the  key. Use the PASS/FAIL indicator to quickly determine whether the channel has passed the limits check. If the channel failed, you can identify the reason(s) for the failure by looking at the symbols that appear in this indicator.

Press the  soft key or the  key again to scroll to the limit check summary. To quickly determine the status of the overall limit check, look at the PASS/FAIL indicator located in the upper portion of the screen. This indicates FAIL if any channel is not within the required limits. For each limit, the worst case value is displayed along with a pass/fail status.

Press the  soft key to sequence through the available test points. The test point that you have selected is represented in the upper portion of the screen by one of the following icons:

-  Subscriber Drop
-  Ground Block
-  Tap
-  User Defined

NOTE

Be sure that you have enabled all of the test points that you are interested in using. The  soft key is only available if there is more than one enabled test point. (see EDIT TEST POINTS).

Only the limits that are enabled in the selected test point will be checked.

NOTE

When viewing the data from an interval, you can print a comprehensive report by pressing SHIFT + .



INGRESS

You can use your CLI-1750 to search for the presence of noise or ingress that can hamper reverse path data communication.

Choose the  icon from the NAVIGATOR. The INGRESS screen will appear:

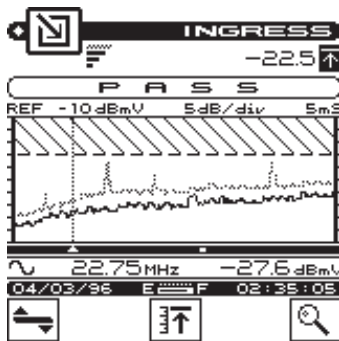

The graph displays frequency on the X-axis and amplitude on the Y-axis.

NOTE

You can select the start frequency, stop frequency and resolution when you configure your LST-1700 (see INGRESS CONFIGURATION).





MOVING THE MARKER

You can use the left or right arrows to move the marker. Frequency and amplitude information for the marker is displayed beneath the graph.





ADJUSTING THE REFERENCE LEVEL

The reference level setting is displayed above the left-hand corner of the graph. This is the amplitude at the **top line** of the graph. You can adjust the reference level using the up and down arrows. When you press the SHIFT +  keys, your CLI-1750 automatically sets the optimum reference level for you.

ADJUSTING THE SCALE

The scale setting is displayed above the graph. You can adjust the scale to provide the best view of the frequency response by pressing the  softkey. A new set of softkeys appear. Use the  and  softkeys to increment and decrement the scale value. Press the  softkey when you have finished.



ZOOMING IN AND OUT

To zoom in or out from the marker, press the  softkey. A new set of softkeys appear. Use the  softkey to zoom in and the  softkey zoom out. Press the  softkey when you have finished.

RESOLUTION

Resolution affects how much detail you see on the graph. Your CLI-1750 allows you to adjust the resolution so that you can optimize the response time depending upon how much detail you want to see.

There are four resolution settings; LOW, MEDIUM, HIGH, and ULTRA. You can increase the resolution by pressing the SHIFT + up arrow or decrease it by pressing the SHIFT + down arrow. You can determine what the current setting is by looking at the resolution indicator in the upper left-hand portion of the display directly below the title bar:

	Low
	Medium







High

Ultra



PEAK MEASUREMENT HOLD

This feature is useful for catching transient or intermittent ingress.

Press the  soft key to toggle the peak hold function on and off.

Notice that the  icon appears in the upper-right portion of the screen whenever peak hold is enabled. The numeric value to the left of the  icon represents the peak level at the marker position. Peak measurements are displayed on the graph as a dimmed trace. Press the  soft key again to release the peak hold function.

MEASUREMENT HOLD

You can freeze the ingress measurement at any time by pressing the SHIFT +  keys. The measurement is retained even if the cable is disconnected from the RF port. Notice that the mode icon in the upper left-hand portion of the screen flashes when the measurement is on hold. Press the SHIFT +  keys again to release the hold. The measurement is not retained when another mode is selected or the CLI-1750 is shut off.

THE PASS/FAIL INDICATOR

You can look to the PASS/FAIL indicator located directly above the graph to quickly determine whether ingress is within tolerance.

NOTE

The PASS/FAIL indicator will only appear when the CHECK LIMIT configuration option has been set to YES (see CHECK LIMIT in the INGRESS CONFIGURATION section).

NOTE

You can specify the PASS/FAIL limit value (see LIMIT VALUE in the INGRESS CONFIGURATION section).

PRINTING THE SCREEN

You can print the entire screen at any time by pressing the SHIFT +  keys. A bar graph appears indicating the status of the printout.

STORING AN INGRESS FILE

Press the SHIFT +  keys to store the current ingress measurement into a file. A screen will appear asking you to enter a name for the file. Once stored, you will be able to recall the file at a later time and view it on the Ingress screen. You will be able to adjust the screen settings the same as when you are viewing a “live” measurement. See the section on VIEW mode to find out how to access files that you have stored.

MODEL CLI-1750/LST-1700

3 Reference

USING THE REFERENCE SECTION

This section provides additional information concerning the use of the CLI-1750. Items to be discussed include; Help, Information, and Technical Support.



The HELP mode provides on-line user assistance by means of context-sensitive help screens. During normal operations, soft key icons appear at the bottom of the display. Each help screen describes the condition of the soft key icons at the time HELP was pressed.

Press the SHIFT +  key to select the HELP mode.

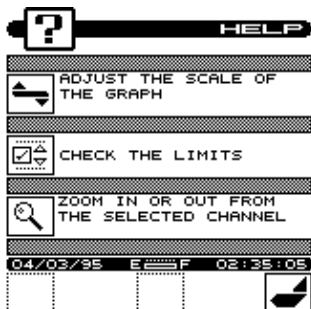

Next to the icon is a brief description of the function that the soft key performs. If an icon is currently inactive "feature not available" is displayed.

INFORMATION

Choose the  icon from the NAVIGATOR. Here you can view information concerning your CLI-1750. The type of information includes; model, frequency range, serial #, firmware version, calibration date, channel plan, memory used, and current temperature.

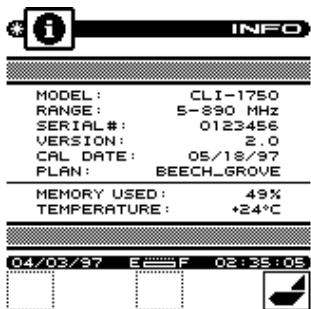

TECHNICAL SUPPORT

Wavetek Wandel Goltermann has worked hard to make the CLI-1750 as easy-to-use as possible. However, if you have a problem using your unit you can contact WWG's Technical Support for help. You can reach WWG's Technical Support Monday through Friday between 8 am and 5 pm EST. at **(800) 622-5515 ext. 8350**. For International Customers, the number to call is **(317) 788-9351**. Questions may be e-mailed to Technical Support Specialists at: catvsupport@wavetek.com

If you received your unit and found it to be damaged or incomplete in any way, phone WWG immediately. Save the shipping carton and packing material in the event that you have to return it.

FOR CUSTOMER SERVICE call WWG at **(800) 851-1198** (inside US), For International Customers, the number to call is **(317) 788-9351**.

MODEL CLI-1750/LST-1700

Appendix A: Specifications

Model CLI-1750 Specifications

Frequency

Range:	5 to 890 MHz
Accuracy:	10 ppm @ 25°C (77° F); 20 ppm over temp.
Tuning Resolution:	25 kHz

Level Measurement

Range:	-20 to +50 dBmV
Resolution:	0.1 dB
Accuracy:	±0.75 dB Flatness, ±0.75 dB Linearity @ 25°C (77° F)
Digital Average Power : (Optional)	±2.0 dB (typical)

Scan Mode

Number of Channels:	120
Scan Rate:	Approximately 6 carriers / second

Leakage Mode

Level Measurement

Input Sensitivity
<u>Video Detection</u> : From 1 µV with LT1000
Leakage Tagger activated (121 to 133.2625MHz)

CW Detection: From 0.5 μ V typical with LT1000
 Leakage Tagger activated (121 to 133.2625 MHz)
Measurement: From 1.4 μ V (115 to 140 MHz)
 Range: 0.5 to 2,000 μ V (at input connector)

Measure Mode

Accuracy: ± 1.5 dB @ 25°C (77° F)

Find and Fix Mode

Accuracy: ± 2.25 dB @ 25°C (77° F)

Tuning

Carrier frequency range: 115 to 140 MHz range
 (Video)

Accuracy: 10 ppm @ 25°C (77° F);
 20 ppm over temp.

Resolution: 25 kHz

Frequency Sweep

Range: 5 to 800 MHz
 Frequency Accuracy: 10 ppm @ 25°C (77° F);
 20 ppm over temp.
 Frequency Resolution: 25 kHz min

Resolution	# Points	Resolution
Ultra	129	Fstop-Fstrt/129
Maximum	65	Fstop-Fstrt/65
Medium	33	Fstop-Fstrt/33
Minimum	17	Fstop-Fstrt/17

Amplitude Accuracy: ± 1 dB (normalized measurement)
 Amplitude Resolution: 0.1 dB
 Display Scale: 1, 2, 5, 10, & 20 dB/div.

Sweep Rate:

Resolution	Max (sec)	Typical (sec)
Ultra	6.125	5.35
Maximum	3.525	3.13
Medium	1.925	1.73
Minimum	1.325	1.22

File Storage Capacity: Dependent upon file type and number of files stored (see example below)

Example:		
Files	Number	Storage
Channel Plans	5	11120
Auto Tests	25	87175
Installations	26	54210
Tilt Files	30	5430
Ingress Files	30	17640
Sweep Files Ultra	30	25200
Locate Files Ultra	25	26925
Location Files	30	2100
Total	201	229800

General

Dimensions: 4.25" wide; 10" high; 2.5" deep

Weight: 1.3 kg (2.9 lb.)

Operating Temp. Range: -10 to +50°C (14 to 122°F) ± 3 dB drift, -10 to +50°C

Water Resistance: Meets or exceeds MIL-STD-810D (Method 506.2)

Power

Battery Life: 2.25 hours continuous (backlight off);
2.25 hours continuous (backlight off) in leakage mode; replaceable battery cartridge;
(charges in optional docking station)

Charge Time: 16 hour charge with unit "off"

Standard Accessories:

AC/DC For charging and/or operating CLI-1750

Charger/Adapter **(See Options for part numbers)**

1019-00-1275 HD-1 Dipole Antenna

1019-00-0479 Battery cartridge for CLI/LST

6510-00-0291 Operating Manual, Models CLI-1750/LST-1700 Home Wiring Test System

Options

1750DIG: For measuring the average power of digital signals
StealthWare: Data management and analysis software (includes 1019-00-0469 , CLI-1750 to PC cable)

LT1000 Leakage Tagger : Differentiates leaks in overbuilt systems, increases detection range, and limits false alarms

DS-1: Vehicle mount "Docking Station" for quick antenna and auxiliary power connection in vehicle

DS-ARM: Adjustable arm mount for docking station to enable viewing of display from driver's seat

VMA-3: Magnetic vehicle mount 1/4 λ whip antenna

1019-00-0591: Durable padded carrying case for Model CLI-1750

1019-00-0479: Field replaceable CLI-1750/LST-1700 battery cartridge (included with CLI-1750/LST-1700)

4010-00-0119: Charger/Adapter, 120VAC to 12VDC.

4010-00-0143: MBC-4 Battery Charger

1019-00-0554: European Charger/Adapter (CE Compliant)

1019-00-0558: Charger/Adapter universal input, 12 VDC output

1019-00-0557: Cigarette lighter adapter

MSCLI Printer: Portable serial thermal fusion printer kit {(Citizen PN-60), 1019-00-0467 MSCLI printer cable included}

1019-00-0467: MSCLI printer cable

1019-00-0468: Generic serial printer cable; CLI-1750 to 25 pin male connector

1019-00-0469: CLI-1750 to PC cable

1019-00-0470: RS232 interconnect cable (included with LST1700)

1019-00-0603: Precision 75 ohm, 1 GHz push on F Connector (Male to Female)

3010-16-0025: Rubber Duck Antenna

1019-00-1275: HD-1 Dipole Antenna

3010-16-0028: HD-1 Antenna Elements

1019-00-1276: HD-1 Pole

Model LST-1700 Specifications

Frequency Sweep

Display: On accompanying Model CLI-1750

Range: 5 to 862 MHz

Accuracy: 10 ppm @ 25°C (77° F); 20 ppm over temp.

Resolution: 25 kHz
 Output Level: +30 dBmV (± 3 dB)
 Amplitude Accuracy: ± 1 dB (normalized measurement)
 Amplitude Resolution: 0.1 dB
 Sweep Rate: 3.5 sec. Max (ultra resolution)

Resolution	Max (sec)	Typical (sec)
Ultra	6.125	5.35
Maximum	3.525	3.13
Medium	1.925	1.73
Minimum	1.325	1.22

Frequency Domain Reflectometry

Measurement displayed on accompanying Model CLI-1750

Locate Rate per Resolution:

Resolution	Sweep Points	Rate (sec)
Ultra	1024	40
Maximum	512	20
Medium	256	10
Minimum	128	5

Resolution, Max Distance and Frequency Span:

V _{op} = 0.82		Max Distance				
Resolution			335'	670'	1341'	2682'
Minimum	64 pts	Span Res	76.8MHz 5.24'	38.4MHz 10.5'	19.2MHz 21'	9.6MHz 42'
Medium	128 pts	Span Res	153.6MHz 2.62'	76.8MHz 5.24'	38.4MHz 10.5'	19.2MHz 21'
Maximum	256 pts	Span Res	307.2MHz 1.31'	153.6MHz 2.62'	76.8MHz 5.24'	38.4MHz 10.5'
Ultra	512 pts	Span Res	614.4MHz 0.65'	307.2MHz 1.31'	153.6MHz 2.62'	76.8MHz 5.24'

Distance Accuracy: Equal to the distance resolution (with constant Vop)
Amplitude Accuracy: ± 3 dB typical @ 25°C (77° F) with known cable attenuation factor and ultra resolution
Range: 0 to -20 dB

CW Signal Generator

Range: 5 to 800 MHz (set in 115 to 140 MHz range for use of CLI-1750 leakage feature)
Accuracy: 10 ppm @ 25°C (77° F);
20 ppm over temp.
Resolution: 25 kHz
Output Level: +30 dBmV

General

Dimensions: 4.25" wide; 10.5" high; 2.5" deep
Weight: 1.14 kg (2.50 lbs.)
Temp. Range: -10 to +50°C; (14 to 122°F)
(Operating)
Water Resistance: Meets or exceeds MIL-STD-810D (Method 506.2)

Power

Battery Life: 4 hours @ 25°C
Charge Time: 16 hour charge with unit "off"

Standard Accessories

Charger/Adapter : AC/DC Charger/Adapter for charging and/ or operating LST-1700
(See **Options** for part numbers)
1019-00-0470: Interconnecting RS232 Cable for communication with CLI-1750
RF Interconnect Cable: (type F connectors)
(42-inch, 75 Ohm)
Operating Manual : 6510-00-0291

Options

1019-00-0590:	Durable padded carrying case for Model LST-1700
1019-00-0588:	Dual soft system carrying case for both the CLI-1750 and the LST-1700
1019-00-0479:	Field replaceable battery cartridge
MBC-6:	Multiple battery cartridge charger
4010-00-0119	Charger/Adapter, 120VAC to 12VDC.
1019-00-0554:	European Charger/Adapter (CE Compliant)
1019-00-0533:	Charger/Adapter universal input, 12VDC output

Precision F-Connector

This instrument is designed to perform accurate level measurements at frequencies greater than 550 MHz. In order to achieve the desired accuracy at higher frequencies, a precision F-connector (2110-06-1029) is installed, and a spare is provided. Replace this connector only with a WWG approved precision F-connector. The life of the F-connector will be extended by keeping a test lead attached to the instrument at all times. If a "Quick-F" adapter is required, WWG recommends using only the 1GHz, 75Ω precision push-on adapter available from the factory. Measurement accuracy at these frequencies is enhanced by using probes prescribed by the amplifier manufacturer. When a probe is not available, a 6 dB pad with good response characteristics throughout the measurement frequency range is recommended at the test point.

For more information about testing at higher frequencies, please refer to WWG's application note, "Considerations in Testing 750 MHz Amplifiers", call 1-800-622-5515, or e-mail catvsupport@wavetek.com.

MODEL CLI-1750/LST-1700

Appendix B: Power Management and Battery

Battery Pack Location and Installation

The battery pack (1019-00-0479) is located on the back of the unit. To remove or replace the battery pack, pull the notched tab downward, and lift the battery pack.

To install the battery pack, insert the bottom of the pack into the groove and press down on the battery pack until it clicks into place.

WARNING: The microStealth battery packs are NOT compatible with CLI-1750 or LST-1700. Only use the battery pack specified for the CLI-1750/LST-1700 or CLI-1450.

Charging the Battery Pack

To recharge the battery pack, plug the AC adapter into the unit. The unit will reach fully charged in 16 hours with unit off, and 30 hours with unit operating. **Use only the AC adapter supplied with the unit or obtained from Wavetek. Use of any other adapter could damage the unit.**

Battery Tips

The CLI-1750 and LST-1700 are shipped from the factory only with a light charge. You should recharge the battery upon receipt of your unit to ensure a full charge.

To maximize battery life of your CLI-1750, set Auto Shutoff to 1 minute and Backlight Shutoff to "always off". These items are described in the Global Configuration section.

MODEL CLI-1750/LST-1700

Appendix C: Interface Port

CONNECTOR

The CLI-1750 and LST-1700 have a serial interface with RS232 drive, using a 3-pin stereo connector. The serial interface has a driver built in for RS232 serial binary data interchange. The connector is located on the bottom of the unit behind a water resistant cover.

Pin Assignments for Interface Port

Signal	Pin	Description
TXD	1	Transmitted Data
RXD	2	Received Data
GND	3	Ground

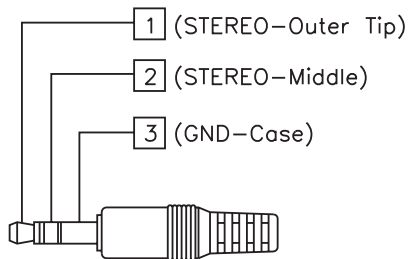

STEREO PLUG DETAIL

CABLE SPECIFICATIONS

CLI-1750 TO PC (1019-00-0469)

STEREO PLUG, LOCATION A

DB9, LOCATION B

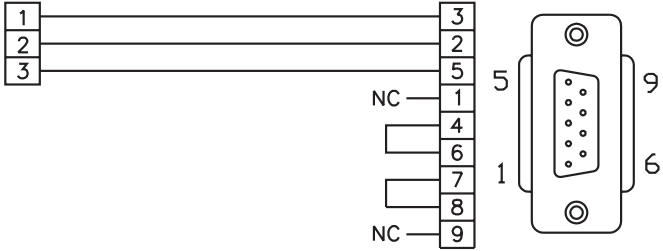

CLI-1750 TO PRINTER(STANDARD) (1019-00-0468)

STEREO PLUG, LOCATION A

DB25, LOCATION B

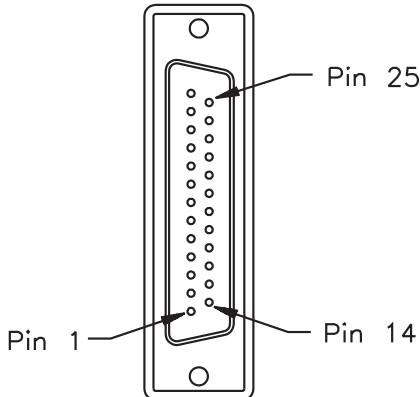
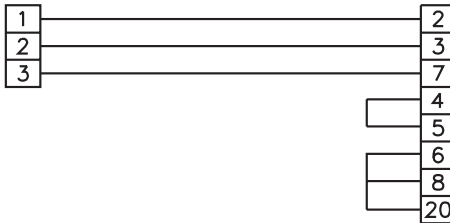

CLI-1750 TO LST-1700 (1019-00-0470); RS232 Cable

STEREO PLUG, LOCATION A

STEREO PLUG, LOCATION B

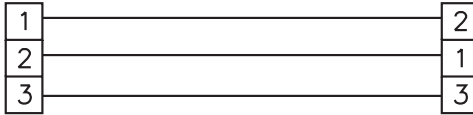

CLI-1450 TO PRINTER(CITIZEN) (1019-00-0467)

STEREO PLUG, LOCATION A

26 PIN, LOCATION B

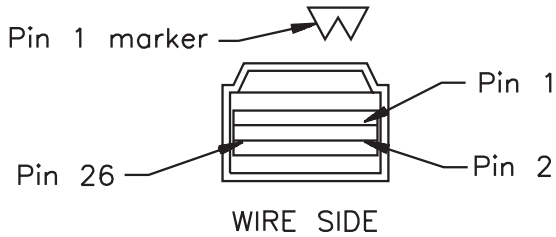
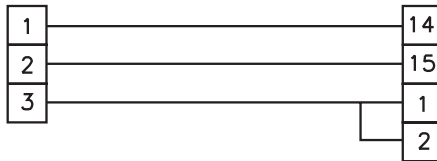

MODEL CLI-1750/LST-1700

D Appendix D: Setting Up A Calibrated Leak Field

INTRODUCTION

Regardless of the type of vehicle mounted antenna used, there are variables that come into play that could cause a change in measured field strength. The position of the antenna on the truck will affect the ground plane and therefore the pattern of the antenna; there may be reflections from other devices mounted on the vehicle (ladder racks, etc.); and even the length of the lead from the antenna to the meter will have an effect on the measurement. This is why it is recommended that a calibrated leak be used to correlate each vehicle's measurement system.

It is sometimes desirable to use a vehicle mounted monopole (VMA-3) or dipole antenna for monitoring and measuring relative leak intensity. If you're using some other antenna other than the VMA-3, you should set up a calibrated leak for verification of accuracy and calibration of the system, which includes the CLI-1750 and whatever antenna and configuration you choose to use. The following procedure describes a setup for this method.

SETUP

The frequency and level of the predictable “leak” should be given careful consideration to avoid interfering with any off-air service or allowing an off-air service to affect the measurement. This leak should be generating a signal only during calibration and disconnected at all other times.

A bandpass cable drop may be used as the leak signal, with a calibrated dipole as the source antenna. (A fixed dipole or a WWG HD-1 Dipole Antenna may be used as the source antenna.) Be sure the dipole is set to the proper length for the chosen monitoring frequency, and that the antenna is mounted with the proper polarization to correspond with the monitoring antenna to be used. Ideally, the calibration antenna should be mounted on a wooden post at the same level as the vehicle mounted antenna. If a vertical monopole antenna is to be used, the source dipole should also be vertical. The drop should be fed through a bandpass filter and an attenuator for adjusting the leak to the correct calibration level.

To set the leak, proceed as follows:

Using a CLI-1750 or other calibrated receiver and a dipole ($1/2 \lambda$) stand at least 10 feet from the leak reference source, and with the antenna 10 feet off the ground and oriented with the proper polarization to the source antenna adjust the drop attenuator until the level on the calibrated receiver matches the desired calibration reference level. (It may be desirable to set the calibration higher than $20 \mu\text{V}/\text{m}$, if the calibrated reference receiver is not sensitive enough to read a $20 \mu\text{V}/\text{m}$ leak).



The calibration area should be as free from obstructions and conductive reflecting surfaces as possible.

1. The following considerations should be taken into account when establishing a reference leak source:
 - a. Potential reference leak source: system signals fed through a source frequency bandpass filter and attenuator.
 - b. Source antenna should be carefully located to isolate it from sources of reflection.

- c. Source antenna should be properly polarized (vertical, if vertical receiving antenna is used).
2. The following considerations should be taken into account when making measurements using a reference leak source:
 - a. Use a half-wave dipole when taking measurements.
 - b. Place dipole 10 feet from the source antenna and 10 feet from ground, oriented with same polarization as source antenna.

CALIBRATION

When a known field is established, the vehicle may be driven through the field and calibrated using the Compensation feature in LEAKAGE mode. (A significant amount of compensation may be required when using vehicle mounted antennas.)

While in the LEAKAGE mode, press the  soft key to adjust compensation. A new set of soft keys will appear. Use the  and  soft keys to increment and decrement the compensation value. You can find the compensation value in the upper right-hand portion of the screen directly below the measurement distance. Adjust the compensation so that the leakage measurement value displayed on the CLI-1750 matches the calibrated reference field.

Press the  soft key when you have finished.

TIP

You can quickly clear out the compensation value by pressing the SHIFT +  keys.

IMPORTANT

Your CLI-1750 stores a separate compensation value for each antenna type. The value automatically goes into effect when you select the antenna. If you use a calibrated leak field, be sure to make the adjustment for each type of antenna that you want to use.

MODEL CLI-1750/LST-1700

Appendix E: Technical Note - VMA-3

INTRODUCTION

The VMA-3 Quarterwave Antenna is a field tunable antenna designed to perform leakage measurements when used with the WWG Model CLI-1450 or CLI-1750 leakage meters. The field tunable $1/4 \lambda$ antenna can be matched to any frequency in the 115-140 MHz range.

INSTALLATION

The VMA-3 is easy to install. To adjust the VMA-3 antenna to the desired frequency:

1. Using the cutting chart, locate the desired frequency (in MHz) on the horizontal axis.
2. Draw a vertical straight line to the point of intersection with the sloping line for the antenna to be tuned.
3. Draw a horizontal straight line to the point of intersection with the vertical axis.
4. Read the approximate length "L" (in inches) of the antenna element from the vertical axis.

It is highly recommended that the element be cut long and trimmed down to the exact frequency desired.

5. Cutting the element may be easier by using the edge of a file or grinding wheel to score the rod around its circumference. Then snap it off with a pair of pliers. **Always cut from the bottom of the element.**
6. Insert the element all the way into the base assembly and tighten with a 3/32" hexagon screw key.

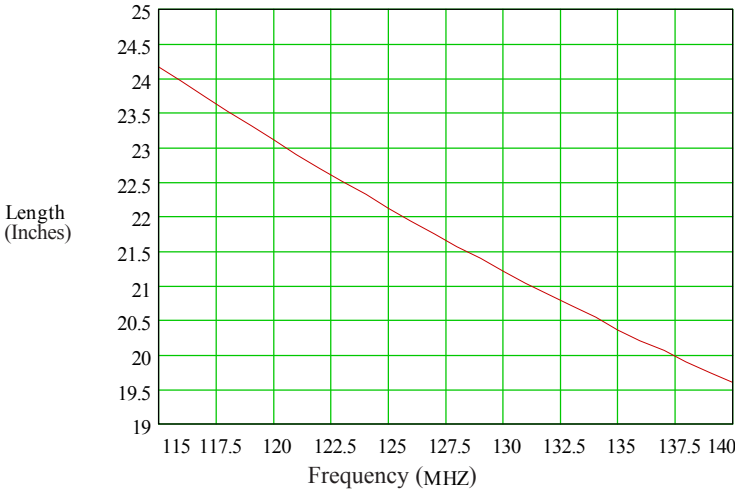

OPERATION

For normal measurements, connect the connector on the antenna assembly directly to the antenna connection on the Model 1450/1750 leakage meter or to the DS-1 Docking Station.

The antenna used in leakage detection is also referred to as a quarter-wave antenna because it is equal in length to one-quarter the measured wavelength in free space.

An antenna's response (receiving or radiation) pattern is determined by its ability to receive or radiate signals when tuned or pointed in one direction. If pointed or tuned otherwise, the antenna's ability to receive is diminished. Maximum performance will be attained by locating the antenna at the center of the vehicle roof. However, satisfactory results can be attained in other locations, such as rear fender or the trunk lid.

CARE AND MAINTENANCE

In order to maximize both the performance and appearance of your antenna, periodic cleaning is recommended.