

Furnace Tracker® TB4095B Rotating Evaporative Thermal Barrier for Annealing and Homogenizing of Tubes in Quench Processes

USER GUIDE



Preparing a Test-piece and Thermocouples

1 Cut out a section from the tube to receive each thermocouple (A). Drill each test-section to receive the thermocouple-tip (B) and an adjacent bolt to clamp it in place (C). Thermocouple length should be equal to the distance from the end of the tube to the test-section, plus the length of the thermal barrier. Pull thermocouples through, and fix to the test-sections.

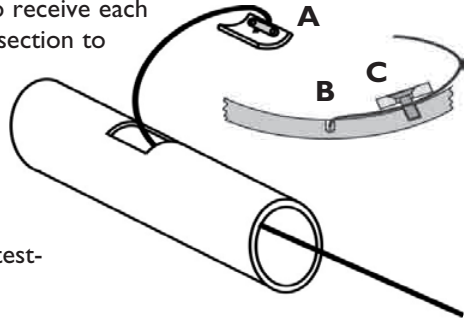

2 Pull the thermocouples back, and weld the test-sections into position.

Fit New Insulation

The microporous insulation of the thermal barrier loses its insulating properties when wet, so must be replaced after every temperature-profile run when it has been soaked in the water quench.

WARNING

If the insulation is not replaced after exposure to water, the data logger and thermal barrier may suffer severe damage.

1 Fit the rear insulation block (D) over the water tank's filler spout and the two retaining pins/studs (E). Then fit the rear plate and secure with R-clips or lock-nuts (depending on model).

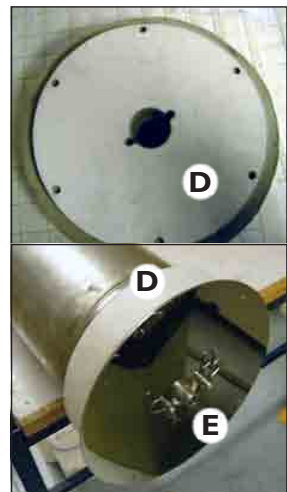

2 Carefully insert the **lid insulation block** into the inside of the thermal barrier's lid, and secure it using a square washer and R-clip (**F**).



3 The **tank insulation** comprises two insulation tubes. The front tube (**G**) can be identified by the slots for the lid locating rods (**I**). Slide both insulation tubes onto the water tank, then seal the joints with glass tape (**J**).

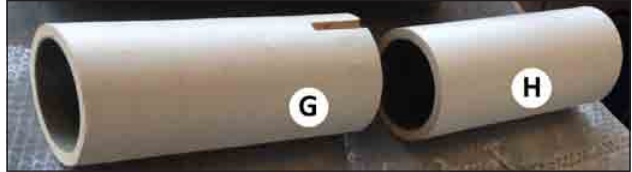

4 Gently align then slide the rear insulation block onto the rear of the water tank (**K**), ensuring that the rear insulation tube slides over the rear block shoulder. Then seal the joint with glass tape (**L**). Repeat the process with the front insulation block (**M**).

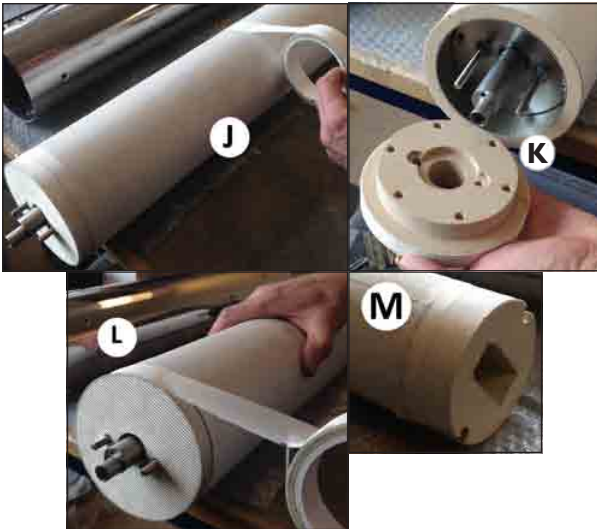

Fit the Insulated Tank into the Barrier Casing

1 To assist with fitting, attach and gently secure the metal back-plate on the end of the rear insulation block (**N**).

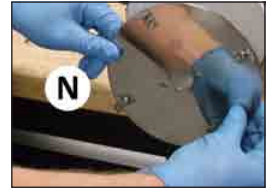

2 Slide the tank with insulation assembly carefully into the outer casing, ensuring that the slots in the insulation tube align with the lid locating-rods at the front of the casing (**O**). Before the insulated tank is fully inside the casing, align the four holes in the rear plate with the four countersunk holes on the outside toward the rear of the casing.



3 Push the insulated tank into the casing until the rear plate is just beyond the four countersunk holes in the casing. With bigger barriers, use long clamps (**OO**) to achieve this.



4 Fit the four brackets that lock the rear plate to the casing (**P**): a countersunk Allen screw is used externally on the casing, and a button-head Allen screw on the rear plate.



5 At the opposite end of the casing, fit the two threaded studs which retain the barrier lid (**Q**): each of the rods is held in place using three countersunk Allen screws.

Setting up the Thermal Barrier and Data Logger

- Fit the compression glands** to the face-plate, with an O-ring in position beneath each gland (**R**).

For information on fitting compression glands, see the 'Furnace Tracker Compression Glands User Guide' (MA5930A).

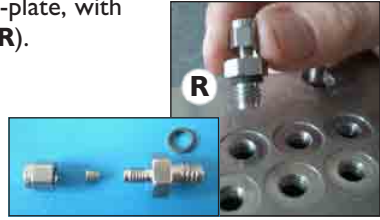

Pull each thermocouple through until the base of the thermocouple-plug pins is 40 mm (1.5 in.) from the inside of the barrier face-plate (**S**), and tighten the nut to finger-tightness. Repeat this for all thermocouples, ensuring that the thermocouple plug pins (+ and -) are all in the same orientation. Bend the thermocouples slightly to ensure all the plugs line up.

Tighten the compression-gland nuts. Do not over-tighten the nut as it will easily shear the compression gland: using an open-ended wrench, tighten until the nut grips, and then a further $\frac{1}{2}$ – $\frac{3}{4}$ turn.

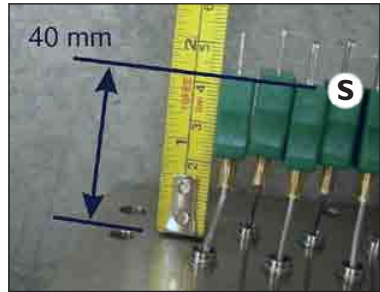

- Reset the data logger** for a new temperature profile run (see the logger's *User Manual*), and plug the thermocouples into the logger. **Start the logger** by pressing its start button (unless a time or temperature trigger has been selected during logger reset).

- Clean the surface of the water tank** at its visible end, and the mating surface of the face-plate which seals the logger inside the thermal barrier, and then **fit the silicone gasket** over the four studs on the end of the tank (**T**).

Always inspect the gasket at every run, and replace it if there are any signs of wear.



4 Fit the logger assembly into the water tank, with the face-plate over the four studs (U, shown without thermocouples in place). Finger-tighten the retaining nuts on the face-plate, alternating between them diagonally, then use a tube wrench (box spanner) to give a final $\frac{1}{4}$ – $\frac{1}{2}$ turn.

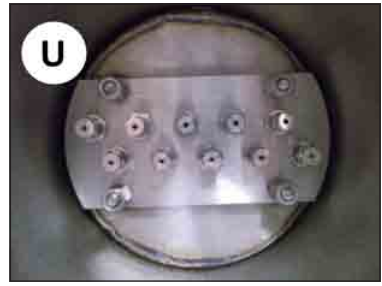

5 Feed the thermocouples out through the exit on the barrier lid. Apply some Molykote high-temperature anti-seize copper grease to the lid's fixing studs, and fit the lid (V). Do not over-tighten the nuts.

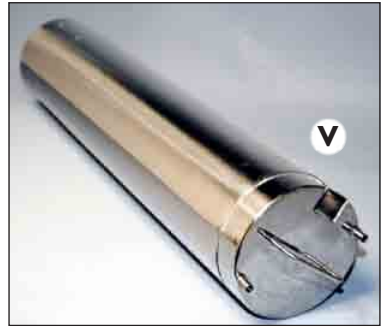

Check the Barrier and Fill with Water



I Before every run, roll the barrier along a flat surface to **check that the internal mechanism of the thermal barrier is rotating freely (W)**. The central filler pipe should remain mainly stationary while the barrier turns; if the filler pipe rotates with the barrier, return the barrier to Datapaq immediately for maintenance.

2 Connect one end of a flexible hose to the filler pipe of the barrier and the other end to a funnel (X). **Fill with the correct amount of water** as specified in the data sheet or quotation.

When the barrier is full, the excess water will begin to escape from the vent hole above the filler tube (Y). Do not overfill as water may leak back into the insulation which will permanently damage it.

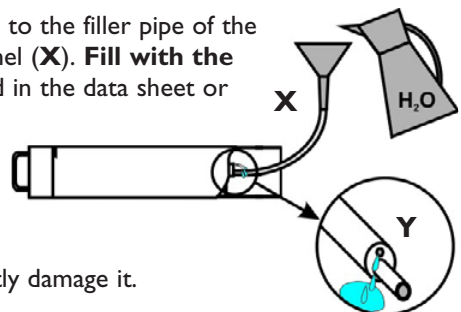

WARNING

Make sure the barrier is horizontal when filling.
Never fill the barrier while it is vertical.

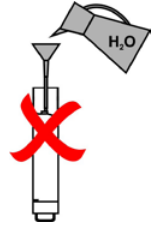

Fit Barrier into Tube

1 If required, fit insulating fiber blanket (**Z**) around the barrier to stabilize it, and **push the barrier into the tube**.

2 To ensure that the barrier rotates with the tube, **secure them together with heavy-gauge wire (★)** through two holes drilled near the end of the tube to match the two fixing holes at the end of the thermal barrier. In some cases, the barrier and tube may be fixed together with bolts.

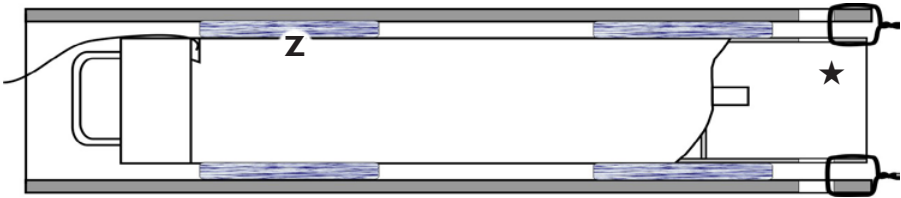

Recovering the Thermal Barrier

At the end of the temperature profile run, immediately cut and remove the wire securing the barrier. Insert a hook (★) to **pull the barrier from the tube**, then remove the logger from the barrier.

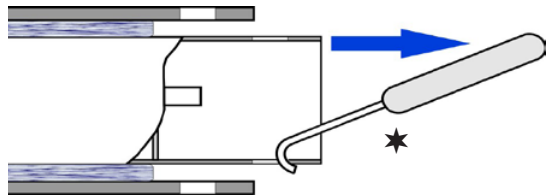

© Datapaq Ltd., Cambridge, UK 2017 All rights reserved

Datapaq Ltd. makes no representations or warranties of any kind whatsoever with respect to the contents hereof and specifically disclaims any implied warranties of merchantability or fitness for any particular purpose. Datapaq Ltd. shall not be liable for errors contained herein or for incidental or consequential damages in connection with the furnishing, performance or use of the Datapaq software, associated hardware or this material. Datapaq Ltd. reserves the right to revise this publication from time to time and to make changes to the content hereof without obligation to notify any person of such revisions or changes.

Datapaq and the Datapaq logo are registered trademarks of Datapaq.
User manuals are available in other languages. Contact Datapaq for details.

Europe & Asia

Datapaq Ltd
Lothbury House,
Cambridge CB5 8PB, UK
Tel: +44-(0)1223-652400
Fax: +44-(0)1223-652401
sales@datapaq.co.uk

North & South America

Datapaq, Inc.,
3 Corporate Park Dr., Unit 1,
Derry, NH 03038, USA
Tel: +1-603-537-2680
Fax: +1-603-537-2685
sales@datapaq.com

www.datapaq.com