

---

# **Agilent 81101A Performance Test**

## Introduction

Use the tests in this chapter if you want to check that the Agilent 81101A 50 MHz Pulse Generator is working correctly. Before starting any testing allow all test equipment to warm up for at least 30 minutes.

## Conventions Used

When referring to actions that you perform during the tests, the following conventions are used:

FUNCTION This indicates that a labelled button must be pressed

[**MODE/TRG**] This shows that a soft-key must be pressed. A soft-key is an unlabelled button whose label is shown on the display, and which can vary according to the job that the button is doing

**CONTINUOUS PULSES** This is an option shown on the display, and is selected by use of the vernier keys. It is shown in upper or lower case to match the case displayed.

## Test Results Tables

Tables for entering the results of the tests are included at the end of this chapter. The tests are numbered and reference numbers for each Test Result (TR) are given in a small table at the end of each test. The reference number shows you where the actual results should be entered in the Test Results Tables.

The Test Results tables at the end of the chapter should be photocopied, and the Test Results entered on the copies. Then, if the tests need to be repeated, the tables can be copied again.

---

## Recommended Test Equipment and Accessories

The following tables list the recommended test equipment you need to perform all the tests in this chapter. You can use alternative instruments if they meet the critical specifications given. The test set-ups and procedures assume you are using the recommended equipment.

Test Equipment	Model	Critical Specifications
Oscilloscope or	Agilent 54121T	20 GHz, 10 bit vertical resolution, Histogram
Oscilloscope	Agilent 54750A + Agilent 54751A	20 GHz, 15 bit vertical resolution, Histogram
Counter or	Agilent 5334B #010, 030	Period and Time Interval measurements Oven Osci, 1.3 GHz C-Channel
Counter	Agilent 53132A #001/010, 030	Frequency measurements > 150 MHz High-Stability Timebase, 3 GHz Channel
Digital Voltmeter	Agilent 3458A	DCV up to 20 V
Pulse Generator	Agilent 8110A	up to 150 MHz
Delay line	Agilent 54008A	22 ns

Agilent 81101A Performance Test

Accessories	Model	Critical Specifications
Digitizing Oscilloscopes Accessories Attenuators	8493C#020 33340C#020 8493C#006 33340C#006	20 dB  6 dB
Power Splitter SMA/SMA (m-m) adaptor SMA/BNC Adaptor  SMA Cable	11667B 1250-1159 E9632A (1250-1700) 8120-4948	
50 $\Omega$ Feedthrough Termination	10100C <b>See Figure</b>	2 W,1% 10 W,0.1%
Adapter	1251-2277	BNC to Banana
Cable Assemblies, BNC	E9637A (8120-1839)	
Torque Wrench	8710-1582	5/16 in, 5 lb-in (56 Ncm)

**NOTE:**

When you connect the test equipment for the first time, and whenever you change the setup during the course of these tests, use the 8710-1582 torque wrench to tighten and loosen SMA connectors. This will ensure that the connectors are at the correct tightness and give the best signal transfer.

### 50 Ohm, 0.1%, 10 W Feedthrough Termination

The following figure provides a schematic and a parts list except for the case. The case must provide shielding and maintain grounding integrity.

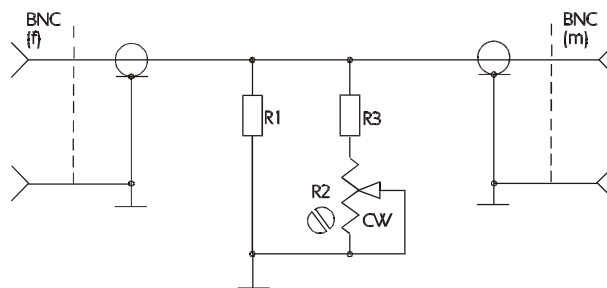

### 50 Ohm, 0.1%, 10 W Feedthrough Termination

The following parts are required:

1. R1 = 53.6 $\Omega$ , 1%, 10 W; Part Number: 0699-0146
2. R2 = 200  $\Omega$ , 10%, 0.5 W, Variable trimmer; Part Number: 2100-3350
3. R3 = 681  $\Omega$ ;, 1%, 0.5 W; Part Number: 0757-0816
4. BNC (M): Part Number: 1250-0045
5. BNC (F): Part Number: 1250-0083

---

## Getting Started

The Agilent 81101A is controlled by selecting options in a series of **pages** that are displayed on the instrument's screen. When the Agilent 81101A is being tested, different situations can arise. The following examples illustrate this

### Typical Examples of Displayed Screens

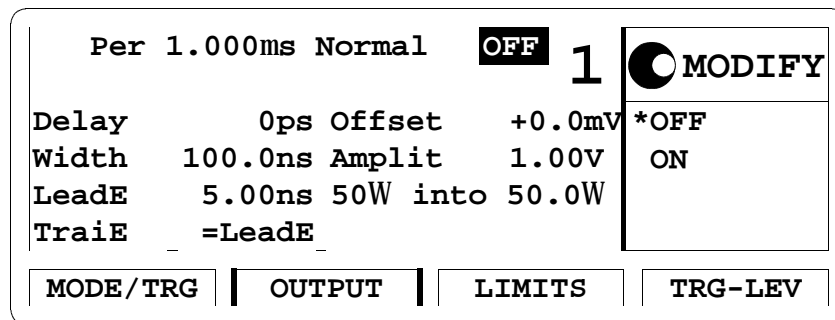

The OUTPUT Screen in a Agilent 81101A

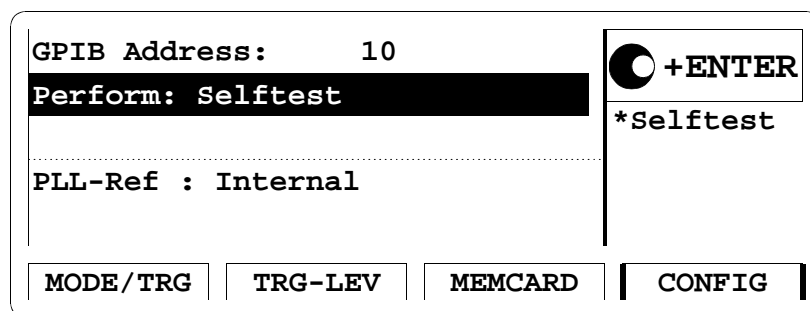

The CONFIG Screen in an Agilent 81101A

## Instrument Serial Numbers

You will need to write the serial numbers of the instrument at the top of the Test Reports. These can be found as follows:

Press HELP, [SERIAL #]

The Agilent 81101A display lists the instrument's product and serial number, firmware revision and date.

The display on your instrument should look similar to this:

```
FRAME      : 81101A      50 MHz  
Serial No   : DE38700132  
FIRMWARE   : 01.00.01  
DATE       : xx/xx/98
```

The serial number given for the **FRAME** applies to the Mainframe, the Power Supply, the Microprocessor Board, and the Timing Board as well as the Output Channel.

## Initial Setup of the Agilent 81101A

In the majority of these tests the initial setting up of the instrument is identical. Therefore, it is described once here, and then referred to where appropriate. In cases where the initial setup differs, an illustration of the settings is shown.

Set up the Agilent 81101A as follows:

1. Select [MODE/TRG]
  - CONTINUOUS PULSES
  - Single-Pulses at Out 1
  - Pulse-Period: internal Osc

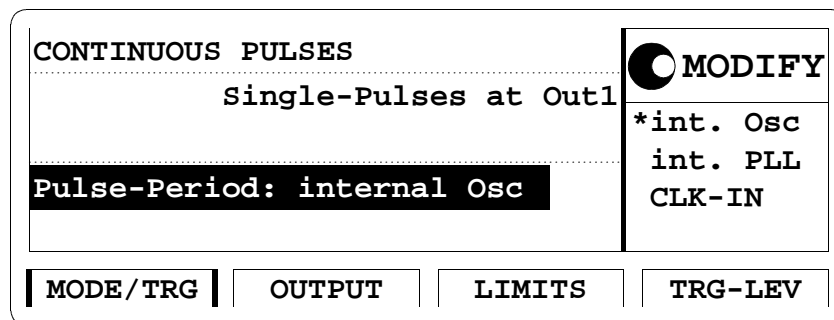

MODE/TRG Screen

---

## Test 1: Period (PLL not active)

### Test Specifications

Range	20 ns to 999.5 s
Resolution	3.5 digits, best case 5 ps
Accuracy	$\pm 5\%$

### Equipment Needed

Counter  
Cable, 50  $\Omega$ , coaxial, BNC

### Procedure

1. Connect the Agilent 81101A to the Counter as shown:

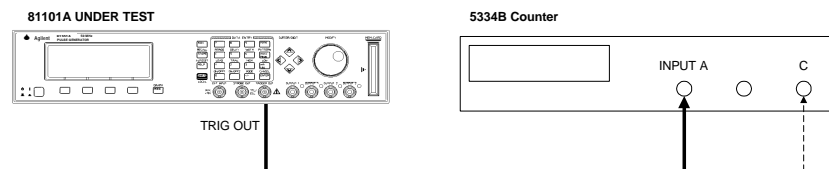

Connecting the Agilent 81101A to the Counter

2. Set up the Agilent 81101A as described in "Initial Setup of the Agilent 81101A"

On the Agilent 81101A set up [OUTPUT] page as shown in the following illustration:

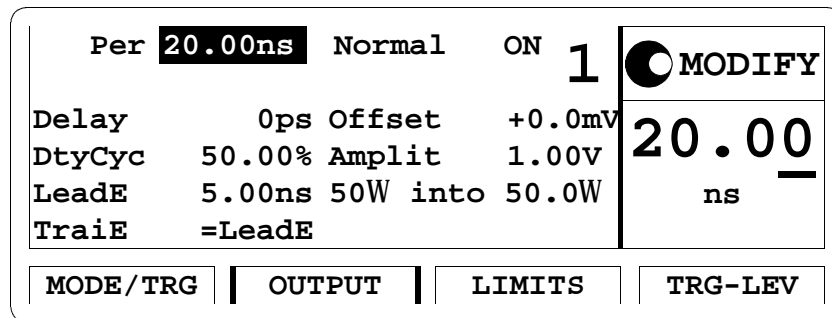

### Configuring Output

3. Set the Counter to:

FUNCTION      Period A  
 INPUT A      50 Ω  
 SENSE        On

4. Check the Agilent 81101A period at the following settings:

Period	Acceptable Range	TR entry
20.00 ns	19.00 ns to 21.00 ns	1 - 1
50.00 ns	47.5 ns to 52.5 ns	1 - 2
99.90 ns	94.905 ns to 104.895 ns	1 - 3

Period	Acceptable Range	TR entry
100 ns	95 ns to 105 ns	1 - 4
500 ns	475 ns to 525 ns	1 - 5
1 $\mu$ s	950 ns to 1050 ns	1 - 6
500 $\mu$ s	475 $\mu$ s to 525 $\mu$ s	1 - 7
500 ms	475 ms to 525 ms	1 - 8

---

## Test 2: PLL Period

**NOTE:** This test is only performed if PLL is switched on.

### Test Specifications

Range 20 ns to 999.5 s  
 Resolution 4 digits, best case 1 ps  
 Accuracy  $\pm 0.01\%$

### Equipment Needed

Counter Agilent 53132A  
 Cable, 50  $\Omega$ , coaxial, BNC

**NOTE:** The Agilent 53132A counter is used in frequency mode to meet the MIL CAL A uncertainty requirements for TAR (Test Accuracy Ratio) > 4:1.

### Procedure

Connect the Agilent 81101A to the counter as follows:

## Agilent 81101A Performance Test

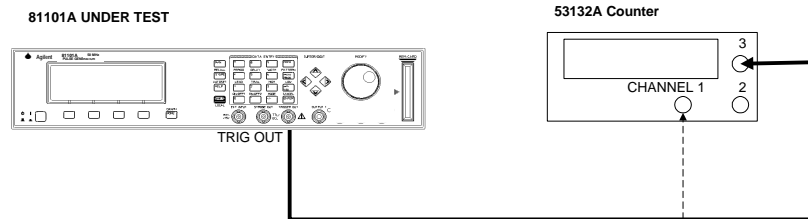

### Connecting Agilent 81101A to the Counter

5. Set up the Agilent 81101A as described in "Initial Setup of the Agilent 81101A"
6. Select the [MODE/TRG] screen on the Agilent 81101A and set up as follows:

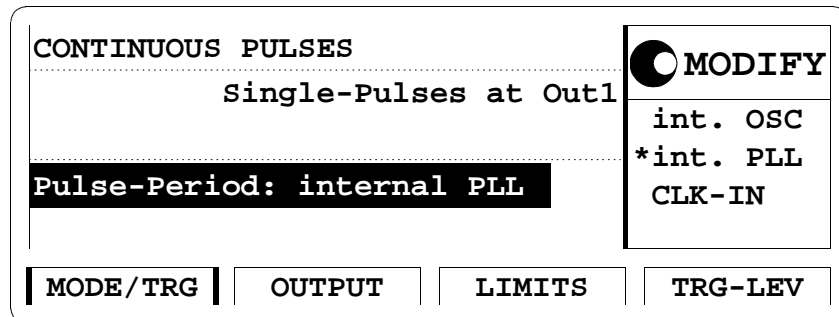

### The MODE/TRG Screen Setup

7. On the Agilent 81101A set up [OUTPUT] page as shown in the test before!

8. Set the Counter to measure the frequency at the chosen input  
1 / 3
9. Check the Agilent 81101A PLL pulse period at the following settings:

Period	Frequency	Acceptable Range	TR Entry
20.00 ns	50 MHz	49.995 MHz to 50.005 MHz	2 - 1
50.00 ns	20 MHz	19.998 MHz to 20.002 MHz	2 - 2
100 ns	10 MHz	9.999 MHz to 10.001 MHz	2 - 3
500 ns	2 MHz	1.9998 MHz to 2.0002 MHz	2 - 4
1 $\mu$ s	1 MHz	999.9 kHz to 1.0001 MHz	2 - 5
50 $\mu$ s	20 kHz	9.998 kHz to 20.002 kHz	2 - 6
5 ms	200 Hz	199.980 Hz to 200.020 Hz	2 - 7
500 ms	2 Hz	1.9998 Hz to 2.0002 Hz	2 - 8
5 s	0.2 Hz	0.19998 Hz to 0.20002 Hz	2 - 9

---

## Test 3: Width

### Test Specifications

Range	10 ns to (period - 10 ns)
Resolution	3.5 digits, best case 5 ps
Accuracy	$\pm 5\% \pm 250$ ps

### Equipment Needed

Digitizing Oscilloscope with Accessories  
Counter  
Cable, 50  $\Omega$ , coaxial, BNC

### Procedure

1. Connect Agilent 81101A to the Scope as shown:

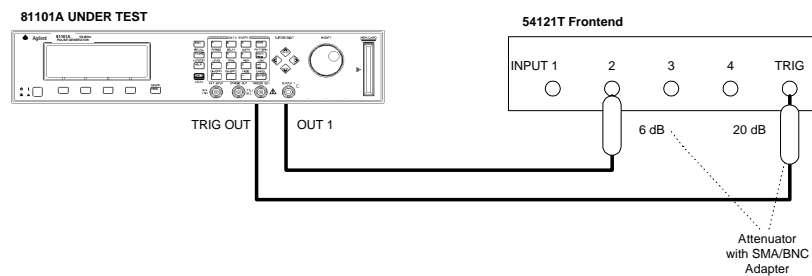

### Connecting Agilent 81101A to the Scope

2. Set up the Agilent 81101A as described in "Initial Setup of the Agilent 81101A"

3. On the Agilent 81101A set up [OUTPUT] page as shown in the following illustration:

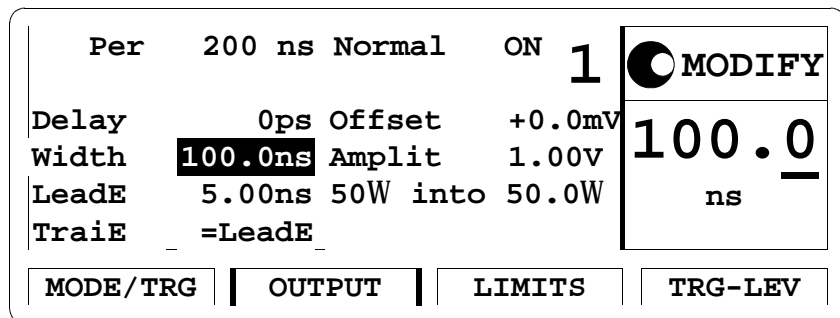

#### Configuring Output Screen

4. Set the Digitizing Oscilloscope Agilent 54121T:
  - Press AUTOSCALE
  - Select the Display menu and set the Number of Averages to 32
  - Select the delta V menu and turn the voltage markers On
  - Set the preset levels to 50% -50% and press AUTO LEVEL SET
  - Select the delta t menu and turn the time markers ON
  - Set START ON EDGE = POS 1 and STOP ON EDGE = NEG1
5. Change the oscilloscope timebase to 1 ns/div
6. Change the Agilent 81101A Width to 10 ns
7. Center the pulse in the Scope display

8. Press the PRECISE EDGE FIND key for each new Width setting
9. Check the Agilent 81101A pulse width at the following settings:

Oscilloscope Timebase	Period	Width	Acceptable Range	TR Entry
2 ns/div	200 ns	10.00 ns	9.250 ns to 10.750 ns	3 - 1
10 ns/div	200 ns	50.00 ns	47.25 ns to 52.75 ns	3 - 2
20 ns/	1 $\mu$ s	100.0 ns	94.75 ns to 105.25 ns	3 - 3
100 ns	1 $\mu$ s	500.0 ns	474.75 ns to 525.25 ns	3 - 4

10. Connect the Agilent 81101A to the Counter as shown:

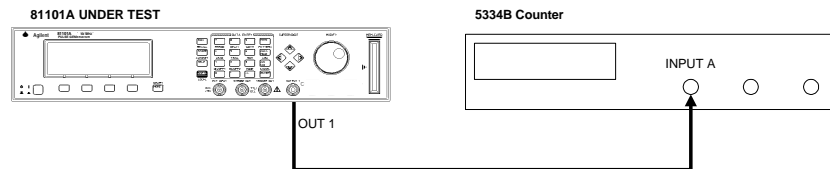

### Connecting Agilent 81101A to the Counter

11. Set the Counter to:

FUNCTION      TI A→ B  
 SENSE          On  
 INPUT A        50 Ω  
 COM A          On  
 INPUT B        50 Ω, negative slope

12. Check the Agilent 81101A width at the following settings:

Period	Width	Acceptable Range	TR Entry
100 μs	50 μs	47.5 μs to 52.5 μs	3 - 6
10 ms	5 ms	4.75 ms to 5.25ms	3 - 7
999 ms	500ms	475 ms to 525 ms	3 - 8

## Test 4: Delay

### Test Specifications

Range	Fixed typical Delay of EXT INPUT to TRIGGER OUT 12 ns TRIGGER OUT to OUTPUT 1/2 17 ns Variable Delay: 0 ns to (period - 20 ns)
Resolution	3.5 digits, best case 5 ps
Accuracy	±5% ±1 ns

### Equipment Needed

Digitizing Oscilloscope with Accessories  
Pulse Generator  
Counter  
Cable, 50 Ω, coaxial, BNC

### Procedure

Connect Agilent 81101A to the Scope as shown:

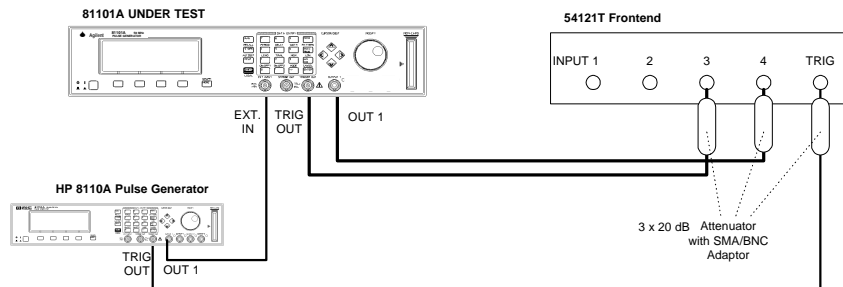

### Connecting Agilent 81101A to the Scope

13. Set up the Agilent 81101A as described in "Initial Setup of the Agilent 81101A"

14. Set the Pulse Generator to:

Period	1 $\mu$ s
Width	100 ns
Amplitude	1 V
Offset	+1.0 V
Output	Enable

15. Select the [MODE/TRG] screen on the Agilent 81101A and set up as follows:

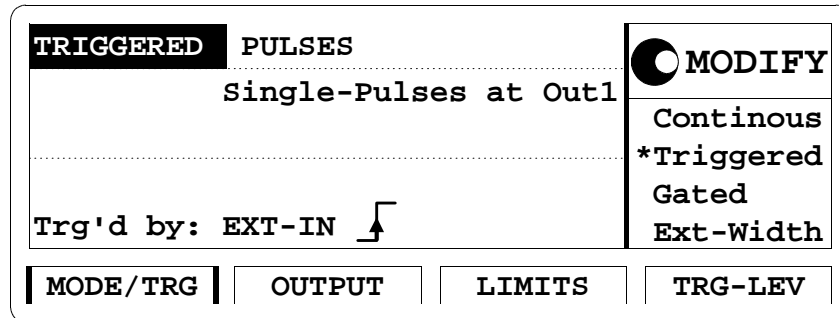

The MODE/TRG Screen Setup

16. On the Agilent 81101A select [TRIG-LEV] page and set up as follows:

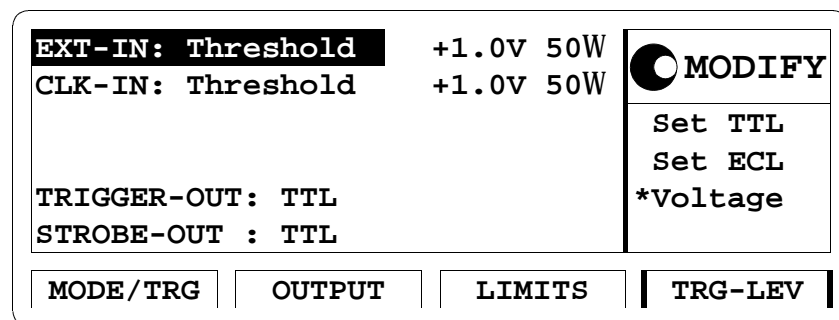

The TRG-LEV Screen Setup

17. On the Agilent 81101A set up [OUTPUT] page as shown in the following illustration:

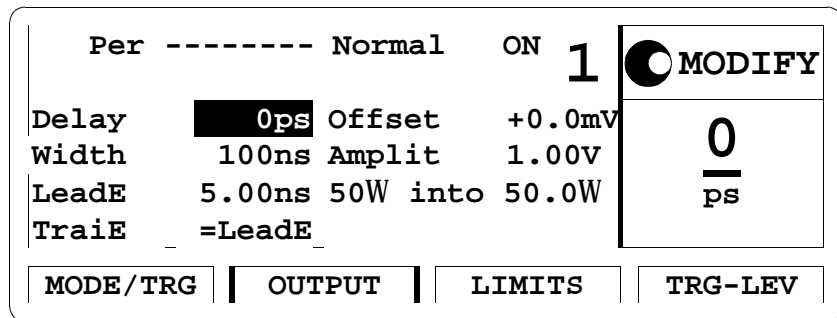

### Configuring Output Screen

18. Set the Digitizing Oscilloscope Agilent 54121T:

- Press AUTOSCALE
- Set timebase to TIME/DIV = 10 ns/div
- Center the positive-going edges of the two signals
- Select the Display menu and set the screen function to single; set the number of averages to 32
- Select the Delta V menu and turn the voltage markers ON and assign marker 1 to channel 3 and marker 2 to channel 4
- Set Preset levels to 50% - 50% and press AUTO LEVEL SET
- Select the Delta t menu and turn the time markers ON
- Set START ON EDGE= POS1 and STOP ON EDGE= POS 1
- Press the PRECISE EDGE FIND key

19. Check the Agilent 81101A delay at the following settings:

**NOTE:**

Record the value of the fixed delay and subtract it from the other readings.

Oscilloscope Timebase	Delay	Acceptable Range	TR Entry
10 ns/div	0 ps	fixed Delay of TRIG OUT to OUT 1/2: 17 ns typ.	4 - 1
10 ns/div	5.000 ns	3.75 ns to 6.25 ns	4 - 2
20 ns/div	10.00 ns	8.500 ns to 11.50 ns	4 - 3
20 ns/div	50.00 ns	46.50 ns to 53.50 ns	4 - 4
50 ns/div	100.0 ns	94.00 ns to 106.00 ns	4 - 5
200 ns/div	500.0 ns	474.00 ns to 526.00 ns	4 - 6

20. Connect the Agilent 81101A to the Counter as follows:

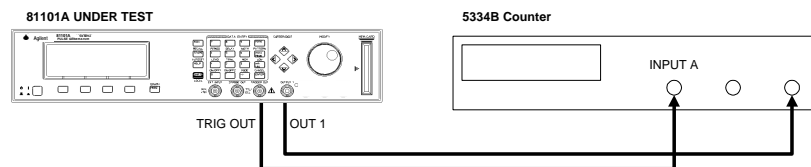

Connecting Agilent 81101A to the Counter

21. Set Agilent 81101A to **Continuous-Pulses** on the MODE/TRG screen

22. Set the Counter to:

FUNCTION TI A → B  
 SENSE On  
 INPUT A 50 Ω  
 INPUT B 50 Ω

23. Check the Agilent 81101A delay at the following settings:

**NOTE:**

Subtract the fixed delay from the other readings

Period	Delay	Acceptable Range	TR Entry
100 μs	50 μs	47.5 μs to 52.5 μs	4 - 7
10 ms	5 ms	4.75 ms to 52.5ms	4 - 8
999 ms	500ms	475 ms to 525 ms	4 - 9

---

## Test 5: Double Pulse Delay

### Test Specifications

Range	20 ns to (period - width - 10 ns)
Resolution	3.5 digits, best case 5 ps
Accuracy	$\pm 5\%$ $\pm 500$ ps

### Equipment Needed

Digitizing Oscilloscope with Accessories  
Counter  
Cable, 50  $\Omega$ , coaxial, BNC

### Procedure

1. Connect Agilent 81101A to the Scope as shown:

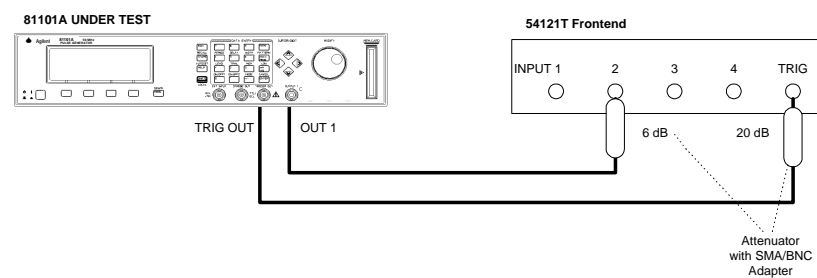

Connecting Agilent 81101A to the Scope

2. Set up the Agilent 81101A as described in "Initial Setup of the Agilent 81101A"
3. Select the [MODE/TRG] screen on the Agilent 81101A and set up Output 1 and Output 2 as follows:

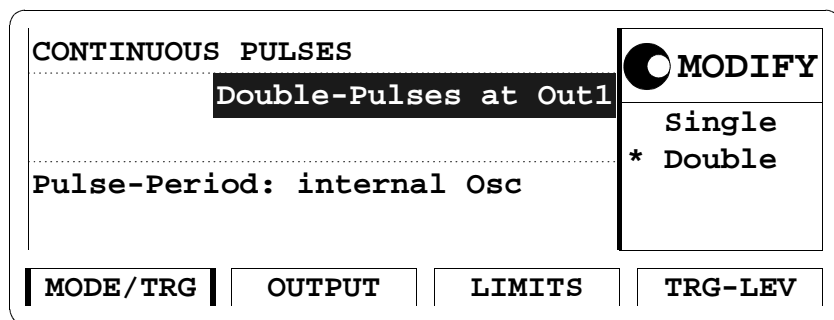

#### The MODE/TRG Screen Setup

4. On the Agilent 81101A set up [OUTPUT] page as shown in the following illustration:

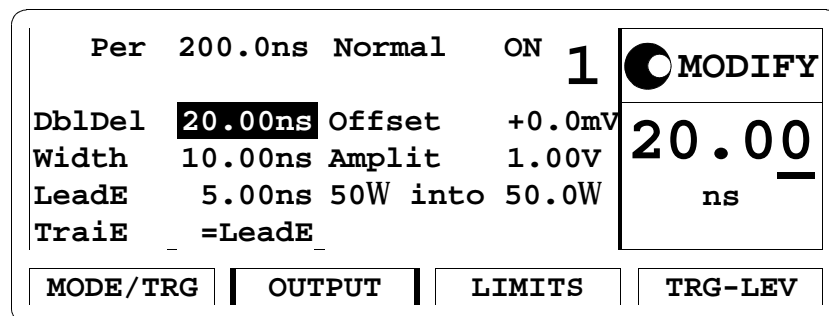

### Configuring Output Screen

5. Set the Digitizing Oscilloscope Agilent 54121T:
  - Press AUTOSCALE
  - Center the double pulse signal
  - Select the Display menu and set the Number of Averages to 32
  - Select the Delta V menu and turn the Voltage markers On
  - Set Preset Levels = 50% -50% and press AUTO LEVEL SET
  - Select the Delta t menu and turn the Time markers On
  - Set START ON EDGE = POS1 and STOP ON EDGE = POS2
6. Press the PRECISE EDGE FIND key for each new Double Delay setting
7. Check the Agilent 81101A double delay at the following settings:

Oscilloscope Timebase	Double Delay	Acceptable Range	TR Entry
2 ns/div	20.00 ns	18.5 ns to 21.5 ns	5 - 1
10 ns/div	50.00 ns	47.00 ns to 53.00 ns	5 - 2
20 ns/div	100.0 ns	94.5 ns to 105.5 ns	5 - 3

8. Connect the Agilent 81101A to the Counter as shown:

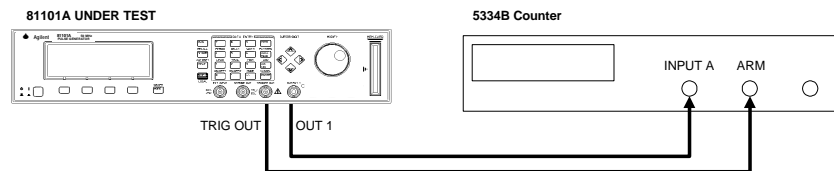

Connecting Agilent 81101A to the Counter

9. Set the Counter to:

- FUNCTION      Period A
- INPUT A      50 Ω
- SENSE        On
- ( EXT ARM
- SELECT      a. Start (ST): leading edge
- b. Stop (SP): trailing edge )

10. Set up the Agilent 81101A as described in "Initial Setup of the Agilent 81101A"

11. Select the [MODE/TRG] screen on the Agilent 81101A and set up as follows;

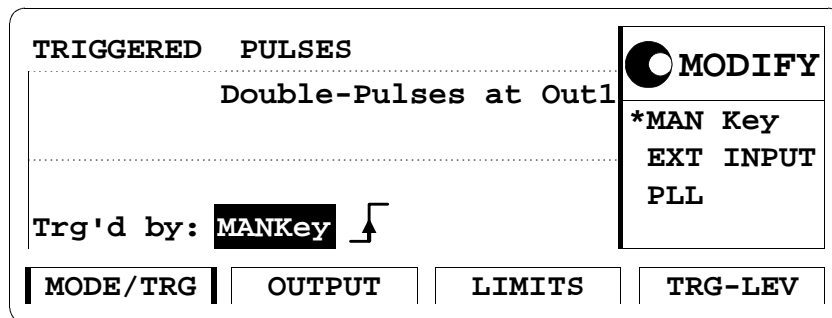

The MODE/TRG Screen Setup

12. On the Agilent 81101A set up [OUTPUT] page as shown in the following illustration:

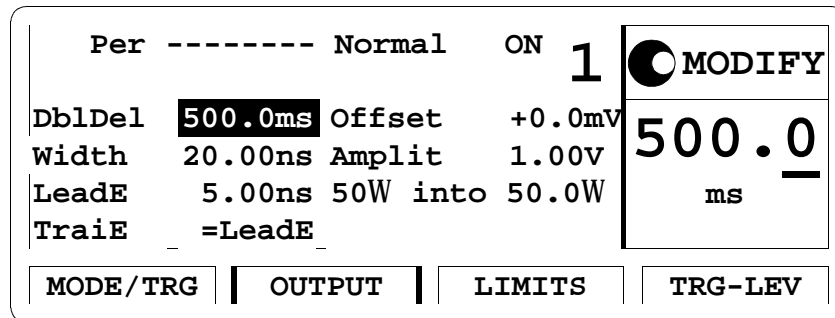

Configuring Output Screen

13. Check the Agilent 81101A double pulse delay at the following settings:

Press MAN to check each new setting!

Double Delay	Acceptable Range	TR Entry
500 ms	475 ms to 525 ms	5 - 4
1 s	950.00 ms to 1050.00 ms	5 - 5

## **Test 6: Jitter**

The following tests are required:

1. Period Jitter
  - a. Internal Oscillator
  - b. Internal PLL
2. Width Jitter
3. Delay Jitter

### **Test 6.1a: Period Jitter, Internal Oscillator**

#### **Test Specifications**

RMS-Jitter 0.01% + 15 ps

#### **Equipment Needed**

Digitizing Oscilloscope with Accessories  
Delay Line (22 ns)  
Power Splitter  
Cable, 50  $\Omega$ , coaxial, BNC  
Cable, SMA

#### **Procedure**

1. Connect Agilent 81101A to the Scope as shown:

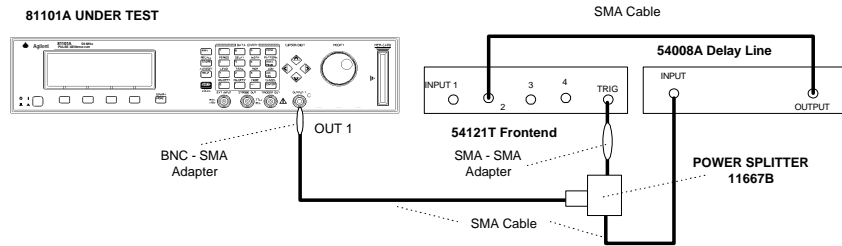

Equipment Set-up for Jitter Test

2. Set up the Agilent 81101A as described in "Initial Setup of the Agilent 81101A"
3. On the Agilent 81101A set up [OUTPUT] page as shown in the following illustration:

Per	<b>50.00ns</b>	Normal	ON	<b>1</b>	<b>MODIFY</b>
Delay	Ops	Offset	+500mV		<b>50.00</b> ns
Width	25.00ns	Amplit	1.00V		
LeadE	5.00ns	50W into	50.0W		
Traie	=LeadE				
MODE/TRG		OUTPUT		LIMITS	
TRG-LEV					

Configuring Output Screen

4. Set the Digitizing Oscilloscope Agilent 54121T:
  - Press AUTOSCALE
  - Select the Display menu and set the Number of Averages to 64
  - Select the Channel menu and set the Attenuation factor of channel 2 to 2
  - Set the VOLTS/DIV of channel 2 to 10 mV/div
  - Set OFFSET to 500 mV
  - Select the Timebase menu and set the TIME/DIV to 100 ps/div
  - Center the first positive-going edge of the signal (approximate Delay = 28ns)
  - Select the Delta V menu and turn the V markers On
  - Set the Marker 1 Position to 490 mV and the Marker 2 Position to 500 mV
  - Select the Delta t menu and turn the T Markers On
  - Set START ON EDGE = POS1 and STOP ON EDGE = POS1
  - Press the PRECISE EDGE FIND key
5. RECORD the delta t reading. This is the rise time of the reference signal within a 1% amplitude window of the signal connected to Input 2. This value is needed later to calculate the correct jitter.(delta.t.up)
6. Select the Timebase menu and center the second positive-going edge of the signal (approximate Delay = 78 ns)
7. Press MORE and HISTOGRAM

- Select the Window submenu and set:
  - Source is channel 2
  - Choose the Time Histogram
  - Press WINDOW MARKER 1 and set it to 490 mV
  - Press WINDOW MARKER 2 and set it to 500 mV
8. Select the Acquire submenu, set the Number of Samples to 1000 and press START ACQUIRING
  9. After the data for the time histogram has been acquired (# Samples = 100%), select the Result submenu.
  10. Press MEAN and SIGMA. RECORD the values of sigma
  11. The RMS-jitter is calculated as follows:

$$RMS - jitter = \frac{6sigma - delta.t.up}{6}$$

12. The RMS-jitter for period of 50 ns is 20 ps. Enter the result in the Test Report as TR entry 6.1a - 1
13. Set the Agilent 81101A period to 500 ns
14. Repeat steps 6 to 11

NOTE:

TIME/DIV = 200 ps/div; approximate Delay = 527 ns

15. The RMS-jitter for period of 500 ns is 65 ps. Enter the result in the Test Report as TR entry 6.1a - 2

## Test 6.1b: Period Jitter, Internal PLL

### Test Specifications

RMS-Jitter 0.001% + 15 ps

### Equipment Needed

Digitizing Oscilloscope with Accessories  
Delay Line (22 ns)  
Power Splitter  
Cable, 50  $\Omega$ , coaxial, BNC  
Cable, SMA

### Procedure

1. Connect Agilent 81101A to the Scope as shown.

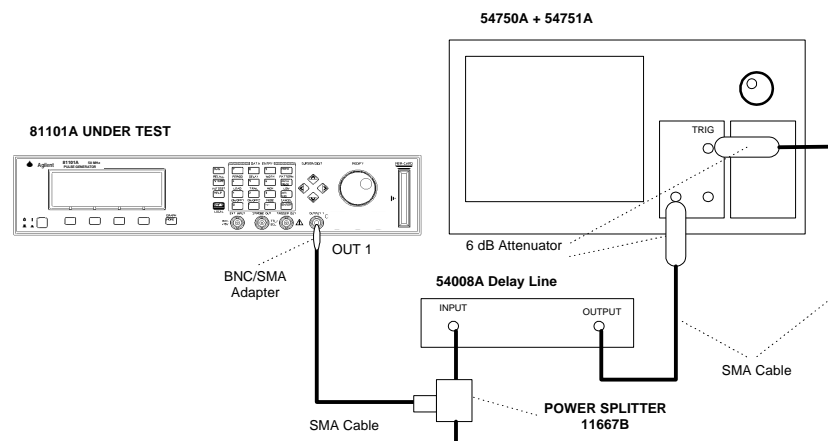

Equipment Set-up for Jitter Test using the Agilent 54750A + 54751A

Using the Agilent 54121T the Set-up is the same as before.

2. Set up the Agilent 81101A as described in "Initial Setup of the Agilent 81101A"
3. Select the [MODE/TRG] screen on the Agilent 81101A and set up as follows:

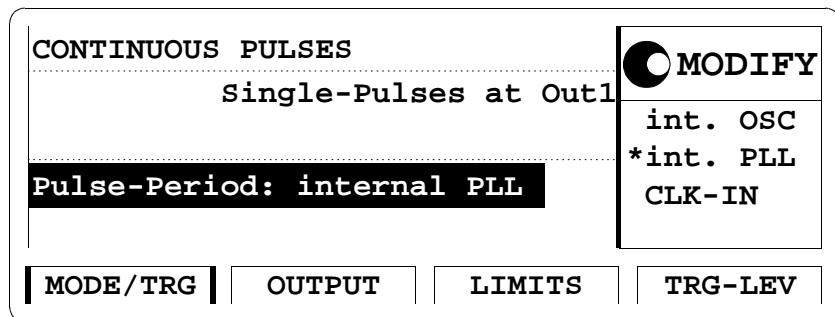

The MODE/TRG Screen Setup

4. On the Agilent 81101A set up [OUTPUT] page as shown in the following illustration:

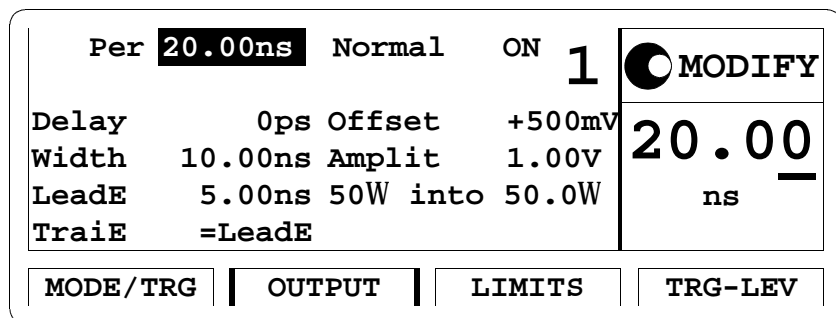

Configuring Output Screen

5. Set the Digitizing Oscilloscope Agilent 54121T:
  - Press AUTOSCALE
  - Select the Display menu and set the Number of Averages to 64
  - Select the Channel menu and set the Attenuation factor of channel 2 to 2
  - Set the VOLTS/DIV of channel 2 to 10 mV/div
  - Set OFFSET to 500mV
  - Select the Timebase menu and set the TIME/DIV to 100 ps/div
  - Center the first positive-going edge of the signal (approximate Delay = 28 ns)
  - Select the Delta V menu and turn the V markers On
  - Set the Marker 1 Position to 490 mV and the Marker 2 Position to 500mV
  - Select the Delta t menu and turn the T Markers On
  - Set START ON EDGE = POS1 and STOP ON EDGE = POS1
  - Press the PRECISE EDGE FIND key
6. RECORD the delta t reading. This is the rise time of the reference signal within a 1% amplitude window of the signal connected to Input 2. This value is needed later to calculate the correct jitter. (delta.t.up)
7. Select the Timebase menu and center the second positive-going edge of the signal (approximate Delay = 78 ns)
8. Press MORE and HISTOGRAM
  - Select the Window submenu and set:

- Source is channel 2
  - Choose the Time Histogram
  - Press WINDOW MARKER 1 and set it to 490 mV
  - Press WINDOW MARKER 2 and set it to 500 mV
9. Select the Acquire submenu, set the Number of Samples to 1000 and press START ACQUIRING
  10. After the data for the time histogram has been acquired (# Samples = 100%), select the Result submenu.
  11. Press MEAN and SIGMA. RECORD the values of sigma
  12. The RMS-jitter is calculated as follows:

$$RMS - jitter = \frac{6\sigma}{6}$$

13. The RMS-jitter for period of 20 ns is 15.2 ps. Enter the result in the Test Report as TR entry 6.1b - 1

---

**NOTE:**

---

See the Agilent54750A User's Guide / Service Guide to get the info needed to do the Jitter Test using this scope.

## Test 6.2: Width Jitter (PLL not active)

### Test Specifications

RMS-Jitter 0.01% + 15 ps

### Equipment Needed

Digitizing Oscilloscope with Accessories  
Delay Line (22 ns)  
Power Splitter  
Cable, 50  $\Omega$ , coaxial, BNC  
Cable, SMA

### Procedure

1. Connect Agilent 81101A to the Scope as shown:

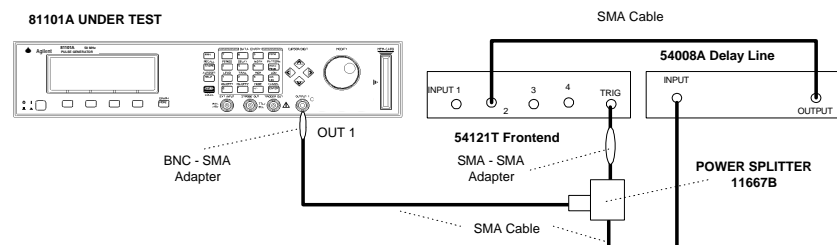

### Equipment Set-up for Jitter Test

2. Set up the Agilent 81101A as described in "Initial Setup of the Agilent 81101A"

3. On the Agilent 81101A set up [OUTPUT] page as shown in the following illustration:

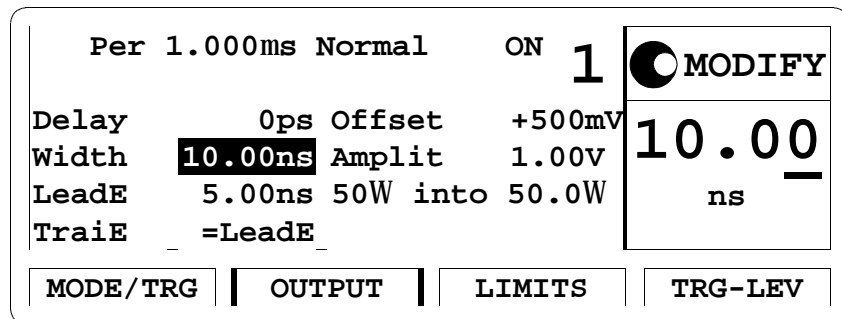

#### Configuring Output Screen

4. Set the Digitizing Oscilloscope Agilent 54121T:
  - Press AUTOSCALE
  - Select the Display menu and set the Number of Averages to 128
  - Select the Channel menu and set the Attenuation factor of channel 2 to 2
  - Set the VOLTS/DIV 500 mV
  - Select the Timebase menu and set the TIME/DIV to 10 ps/div
  - Center the first negative-going edge of the signal (approximate Delay = 36 ns)
  - Select the Delta V menu and turn the V markers On

- Set the Marker 1 Position to 500 mV and the Marker 2 Position to 490 mV
  - Select the Delta t menu and turn the T Markers On
  - Set START ON EDGE = NEG1 and STOP ON EDGE = NEG1
  - Press the PRECISE EDGE FIND key
5. RECORD the delta t reading. This is the fall time of the reference signal within a 1% amplitude window of the signal connected to Input 2. This value is needed later to calculate the correct jitter. (delta.t.dn)
  6. Set the Agilent 81101A Pulse Width to 50 ns
  7. Select the Timebase menu and center the first negative-going edge of the signal (approximate Delay = 77 ns)
  8. Press MORE and HISTOGRAM
  9. Select the Window submenu and set:
    - Source is channel 2
    - Choose the Time Histogram
    - Press WINDOW MARKER 1 and set it to 500 mV
    - Press WINDOW MARKER 2 and set it to 490 mV
  10. Select the Acquire submenu, set the Number of Samples to 1000 and press START ACQUIRING
  11. After the data for the time histogram has been acquired (# Samples = 100%), select the Result submenu.

12. Press MEAN and SIGMA. RECORD the value of sigma

13. The RMS-jitter is calculated as follows:

$$\text{RMS - jitter} = \frac{6 \text{ sigma} - \text{delta.t.dn}}{6}$$

14. The RMS-jitter for pulse width of 50 ns is 20 ps. Enter the result in the Test Report as TR entry 6.2 - 1

15. Set the Agilent 81101A for pulse width of 500ns

16. Repeat steps 7 to 13

---

***NOTE:***

TIME/DIV = 100ps/div. Approximate delay = 527 ns

17. The RMS-jitter for pulse width of 500 ns is 65 ps. Enter the result in the Test Report as TR entry 6.2 - 2

### Test 6.3: Delay Jitter (PLL not active)

#### Test Specifications

RMS-Jitter 0.01% + 15 ps

#### Equipment Needed

Digitizing Oscilloscope with Accessories

#### Procedure

1. Connect Agilent 81101A to the Scope as shown:

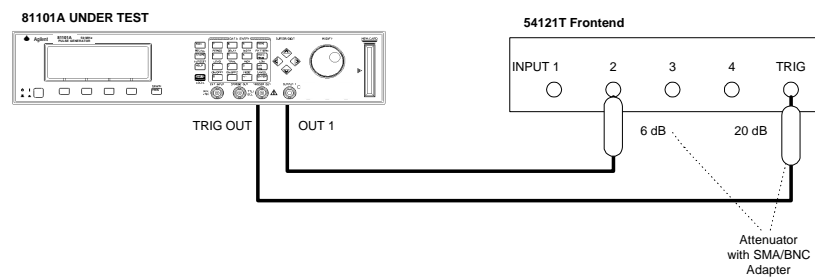

#### Equipment Set-up for Delay Jitter Test

2. For calculating the RMS-jitter, the rise time of the reference signal within a 1% amplitude window is required. If this value

is not already measured in the Period Jitter test, then perform the first 6 steps of the Period Jitter test.

3. Set up the Agilent 81101A as described in "Initial Setup of the Agilent 81101A"
4. On the Agilent 81101A set up [OUTPUT] page as shown in the following illustration:

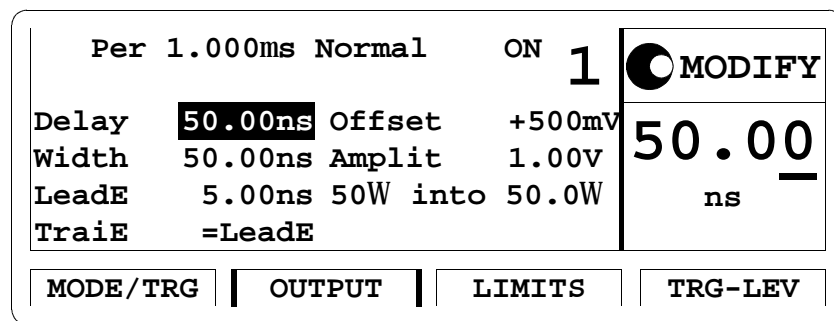

#### Configuring Output Screen

5. Set the Digitizing Oscilloscope Agilent 54121T:
  - Press AUTOSCALE
  - Select the Display menu and set the Number of Averages to 64
  - Set the VOLTS/DIV = 10 mV/div
  - Set OFFSET to 500 mV
  - Select the Timebase menu and set the TIME/DIV to 100 ps/div
  - Center the first positive-going edge of the signal (approximate Delay = 65 ns)

6. Press MORE and HISTOGRAM
7. Select the Window submenu and press WINDOW MARKER 1 and set it to 490 mV
8. Press WINDOW MARKER 2 and set it to 500 mV
9. Select the Acquire submenu, set the Number of Samples to 1000 and press START ACQUIRING
10. After the delta for the time histogram has been acquired (# Samples = 100%), select the Result submenu.
11. Press MEAN and SIGMA. RECORD the values of sigma!
12. The RMS-jitter is calculated as follows:

$$\text{RMS - jitter} = \frac{6\sigma - \text{delta.t.up}}{6}$$

13. The RMS-jitter for delay of 50 ns is 20 ps. Enter the result in the Test Report as TR entry 6.3 - 1
14. Set Agilent 81101A for delay of 500 ns
15. Repeat steps 9 to 12

NOTE:

TIME/DIV = 100 ps/div. Approximate delay = 515 ns

16. The RMS jitter for delay of 500 ns is 65 ps. Enter the result in the Test Report as TR entry 6.3 - 2



## Test 7: High and Low Levels

The following tests are required:

1. High level from  $50\Omega$  into  $50\Omega$
2. Low level from  $50\Omega$  into  $50\Omega$
3. High level from  $1K\Omega$  into  $50\Omega$
4. Low level from  $1K\Omega$  into  $50\Omega$

## Test Specifications

	Load Impedance $50\Omega$	
Source Impedance	$50\Omega$	$1K\Omega$
High Level	-9.90 V to +10.0 V	-19.8 V to +20.0 V
Low Level	-10.0 V to +9.9 V	-20.0 V to +19.8 V
Amplitude	0.10 V <sub>pp</sub> to 10.0 V <sub>pp</sub>	0.20 V <sub>pp</sub> to 20.0 V <sub>pp</sub>
Level Resolution	10 mV	20 mV
Level Accuracy	$\pm 3\%$ of ampl $\pm 75$ mV	$\pm 5\%$ of ampl $\pm 150$ mV for amplitude $\leq 19$ V

## Equipment Needed

1. Digitizing Voltmeter (DVM)
2.  $50\Omega$  Feedthrough Termination, 0.1%, 10 W Adapter.
3. BNC to dual banana plug (1251-2277)
4. Cable,  $50\Omega$ , coaxial, BNC

## Procedure

Connect Agilent 81101A to the DVM as shown:

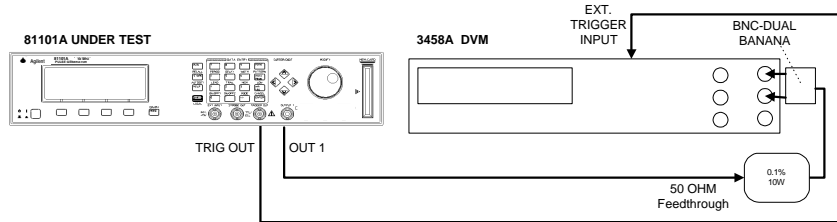

Connecting the DVM for High and Low Levels Tests

**Test 7.1: High Level, 50 Ohms into 50 Ohms**

1. Set up the Agilent 81101A as described in "Initial Setup of the Agilent 81101A"
2. On the Agilent 81101A set up [OUTPUT] page as shown in the following illustration:

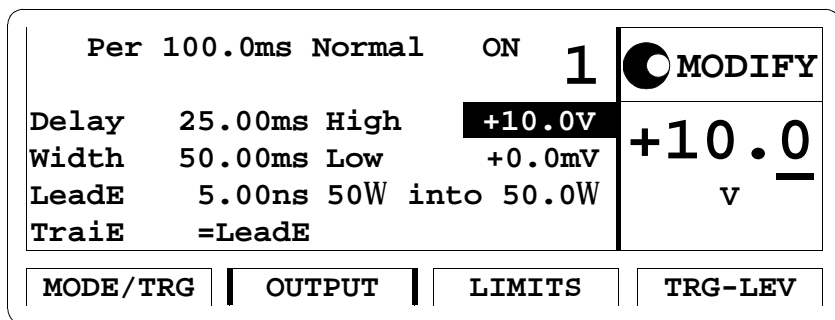

Configuring Output Screen

3. Set the DVM Agilent 3458A to:

Function: DCV  
Trigger: TRIG EXT  
AD-Converter integration time NPLC: 0.1  
(Number of Power Line Cycles)

4. Check the Agilent 81101A high level at the following high level settings with the low level set to 0.0 V.

High Level	Acceptable Range	TR Entry
10.0 V	9.625 V to 10.375 V	7.1 - 1
5.0 V	4.775 V to 5.225 V	7.1 - 2
3.0 V	2.845 V to 3.165 V	7.1 - 3
1.0 V	0.895 V to 1.105 V	7.1 - 4
0.5 V	410 mV to 590 mV	7.1 - 5
0.1 V	22 mV to 178 mV	7.1 - 6

The low level may vary within  $\pm 3\%$  of amplitude  $\pm 75$  mV

### Test 7.2: Low Level, 50 Ohms into 50 Ohms

1. Set up the Agilent 81101A as described in "Initial Setup of the Agilent 81101A"
2. On the Agilent 81101A set up [OUTPUT] page as shown in the following illustration:

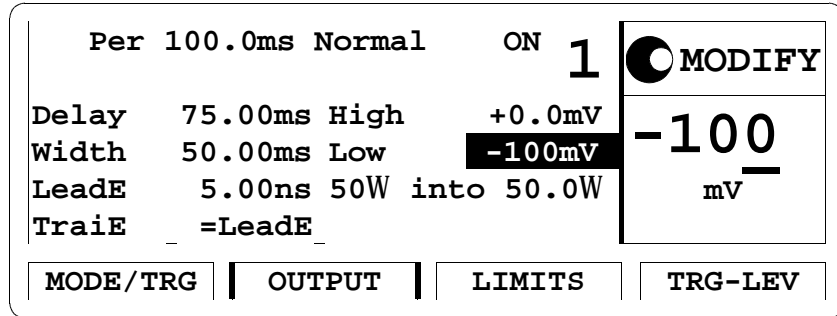

Configuring Output Screen

3. Check the Agilent 81101A low level at the following low level settings with the high level set to 0.0 V

Low Level	Acceptable Range	TR Entry
-0.1 V	-22 mV to -178 mV	7.2 - 1
-0.5 V	-410 mV to -590 mV	7.2 - 2
-1.0 V	-0895 V to -1.105 V	7.2 - 3
-3.0 V	-2.845 V to -3.165 V	7.2 - 4
-5.0 V	-4.775 V to -5.225 V	7.2 - 5
-10.0 V	-9.625 V to -10.375 V	7.2 - 6

The high level 0.0 V may vary  $\pm 3\%$  of amplitude  $\pm 75$  mV.

**Test 7.3: High Level, 1K Ohms into 50 Ohms**

1. Set up the Agilent 81101A as described in "Initial Setup of the Agilent 81101A"
2. On the Agilent 81101A set up [OUTPUT] page as shown in the following illustration:

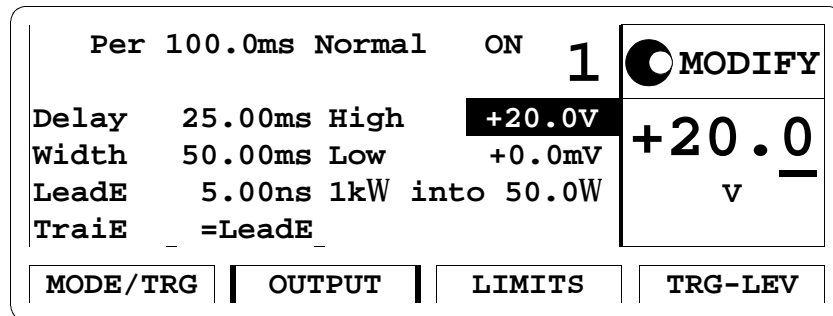

### Configuring Output Screen

3. Check the Agilent 81101A high level at the following high level settings with the low level set to 0.0 V.

High Level	Acceptable Range	TR Entry
19.0 V	17.9 V to 20.1 V	7.3 - 1
10.0 V	9.35 V to 10.65 V	7.3 - 2
5.0 V	4.60 V to 5.40 V	7.3 - 3
1.0 V	0.80 V to 1.20 V	7.3 - 4
0.2 V	40 mV to 360 mV	7.3 - 5

The low level 0.0 V may vary  $\pm 5\%$  of amplitude  $\pm 150$  mV.

### Test 7.4: Low Level, 1K Ohms into 50 Ohms

1. Set up the Agilent 81101A as described in "Initial Setup of the Agilent 81101A"
2. On the Agilent 81101A set up [OUTPUT] page as shown in the following illustration:

Per 100.0ms Normal		ON	1	 MODIFY
Delay	75.00ms High		+0.0mV	-200 mV
Width	50.00ms Low		-200mV	
LeadE	5.00ns 1kW into		50.0W	
TraIE	=LeadE			
MODE/TRG		OUTPUT	LIMITS	TRG-LEV

### Configuring Output Screen

3. Check the Agilent 81101A low level at the following low level settings with the high level set to 0.0 V.

Low Level	Acceptable Range	TR Entry
-0.2 V	-40 mV to -360 mV	7.4 - 1
-1.0 V	-0.80 V to -1.20 V	7.4 - 2
-5.0 V	-4.60 V to -5.40 V	7.4 - 3
-10.0 V	-9.350 V to -10.650 V	7.4 - 4
-19.0 V	-17.90 V to -20.10 V	7.4 - 5

The high level 0.0 V may vary  $\pm 5\%$  of amplitude  $\pm 150$  mV

## Test 8: Transition Time

### Test Specifications

Range	5.0 ns to 200 ms (measured between 10% and 90% of amplitude)
Accuracy	$\pm 10\%$ $\pm 200$ ps
Linearity	typical $\pm 3\%$ for transitions $> 100$ ns

### Equipment Needed

Digitizing Oscilloscope with Accessories  
Cable, SMA

### Procedure

Perform the tests as shown in the following sections:

### Test 8.1a: Leading Edge Test

Minimum Leading Edge and Leading Edge ranges .

1. Connect Agilent 81101A to the Scope as shown:

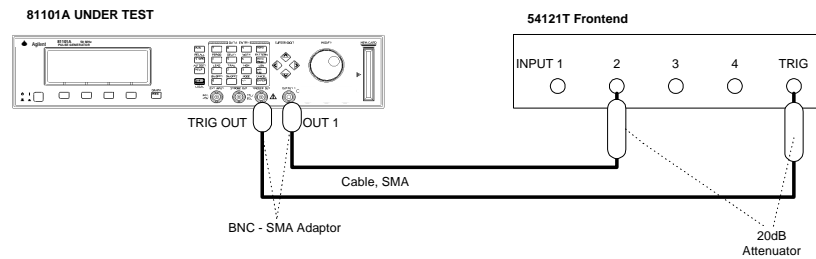

Connecting Agilent 81101A to the Scope

---

**NOTE:**

When you connect the test equipment the first time, and whenever you change the setup during the following tests, use the torque wrench (8170-1582) to tighten and loosen the SMA connectors. This will ensure that the connectors are at the correct tightness and give the best signal transfer!

- 
2. Set up the Agilent 81101A as described in "Initial Setup of the Agilent 81101A"
  3. On the Agilent 81101A set up [OUTPUT] page as shown in the following illustration:

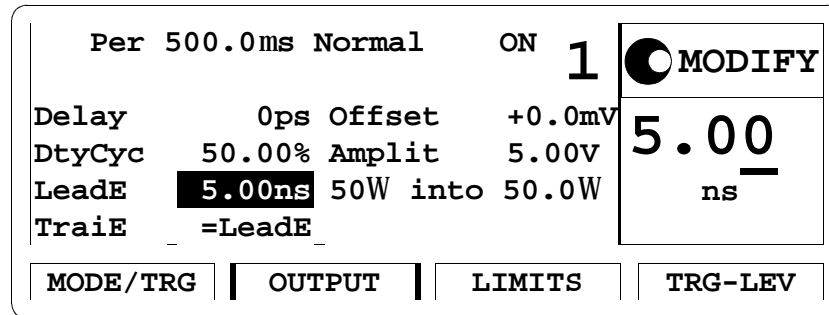

#### Configuring Output Screen

4. Set the Digitizing Oscilloscope Agilent 54121T:
  - Press AUTOSCALE
  - Center one pulse on screen, e.g.:
  - TIME/DIV = 50  $\mu$ s/div, DELAY = 380  $\mu$ s,
  - Select the Display menu and set the Number of Averages to 32
  - Select the Channel menu and set the Attenuation factor to 10
  - Select the Delta V menu and turn the voltage markers On
  - Set the Preset Levels = 10-90% and press AUTO LEVEL SET
  - Select the Timebase menu and set TIME/DIV = 1 ns/div, DELAY = 20 ns
  - Select the Delta t menu and turn the markers On
  - Set START ON EDGE = POS1 and STOP ON EDGE = POS1
  
5. Set period of Agilent 81101A to: Period = 1  $\mu$ s and change the Agilent 81101A Delay to center the leading edge of the first pulse on the screen

6. After the averaging, while the oscilloscope is in the Delta t menu, Press the PRECISE EDGE FIND key
7. Check the Agilent 81101A rise times at the following leading edge settings:

Oscilloscope TIME/ DIV	Period	Leading Edge	Trailing Edge	Acceptable Range	TR Entry
2 ns/div	1 $\mu$ s	5.0 ns	5.0 ns	$\leq$ 5 ns to 5.7 ns	8.1a - 1
5 ns/div	1 $\mu$ s	10 ns	10 ns	8.8 ns to 11.2 ns	8.1a - 2
10 ns/div	1 $\mu$ s	50 ns	50 ns	44.8 ns to 55.2ns	8.1a - 3
100 ns/div	5 $\mu$ s	500 ns	500 ns	449.8 ns to 550.2 ns	8.1a - 4
1 $\mu$ s/div	50 $\mu$ s	5 $\mu$ s	5 $\mu$ s	4.4998 $\mu$ s to 5.5002 $\mu$ s	8.1a - 5
10 $\mu$ s/div	500 $\mu$ s	50 $\mu$ s	50 $\mu$ s	45 $\mu$ s to 55 $\mu$ s	8.1a - 6
100 $\mu$ s	5 ms	500 $\mu$ s	500 $\mu$ s	450 $\mu$ s to 550 $\mu$ s	8.1a - 7
10 ms/div	500 ms	50 ms	50 ms	45 ms to 55 ms	8.1a - 8

### Test 8.1b: Trailing Edge Test

Minimum Trailing Edge and Trailing Edge range.

1. Connect Agilent 81101A to the Scope as shown in Test 8.1a Leading Edge Test.
2. Set up the Agilent 81101A as described in Test 8.1a Leading Edge Test.
3. Set the digitizing oscilloscope Agilent 54121T:
  - Select the oscilloscopes Timebase menu and set TIME/DIV to 1 ns/div and DELAY to approximately 520ns
  - Select the oscilloscopes Delta t menu and set START ON EDGE = NEG1 and STOP ON EDGE = NEG1
4. While the oscilloscope is in the Delta t menu, press the PRECISE EDGE FIND key
5. Check the Agilent 81101A output signal falls at the following trailing edge settings:

Oscilloscope TIME/DIV	Delay	Period	Trailing Edge	Leading Edge	Acceptable Range	TR Entry
2 ns/div	529 ns	1 $\mu$ s	5.0 ns	5.0 ns	$\leq$ 5 ns to 5.7 ns	8.1b - 1
5 ns/div	529 ns	1 $\mu$ s	10 ns	5 ns	8.8 ns to 11.2 ns	8.1b - 2
10 ns/div	529 ns	1 $\mu$ s	50 ns	50 ns	44.8 ns to 55.2 ns	8.1b - 3
100 ns/div	25 $\mu$ s	5 $\mu$ s	500 ns	500 ns	449.8 ns to 550.2 ns	8.1b - 4
1 $\mu$ s/div	25 $\mu$ s	50 $\mu$ s	5 $\mu$ s	5 $\mu$ s	4.4998 $\mu$ s to 5.5002 $\mu$ s	8.1b - 5
10 $\mu$ s/div	250 $\mu$ s	500 $\mu$ s	50 $\mu$ s	50 $\mu$ s	45 $\mu$ s to 55 $\mu$ s	8.1b - 6
100 $\mu$ s/div	2.5 ms	5 ms	500 $\mu$ s	500 $\mu$ s	450 $\mu$ s to 550 $\mu$ s	8.1b - 7
10 ms/div	250 ms	500 ms	50 ms	50 ms	45 ms to 55 ms	8.1b - 8

### Test 9: Pulse Aberration Test

The following tests are required:

Overshoot and Ringing  
Preshoot

### Test Specifications

Overshoot/Preshoot/Ringing  
 $\pm 5\%$  of amplitude  $\pm 20$  mV

### Equipment Needed

Digitizing Oscilloscope with Accessories

### Procedure

6. Set up the Agilent 81101A as described in "Initial Setup of the Agilent 81101A"
1. Connect Agilent 81101A to the Scope as shown:

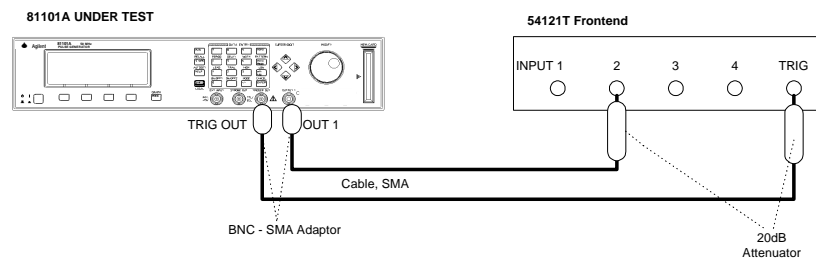

Connecting Agilent 81101A to the Scope

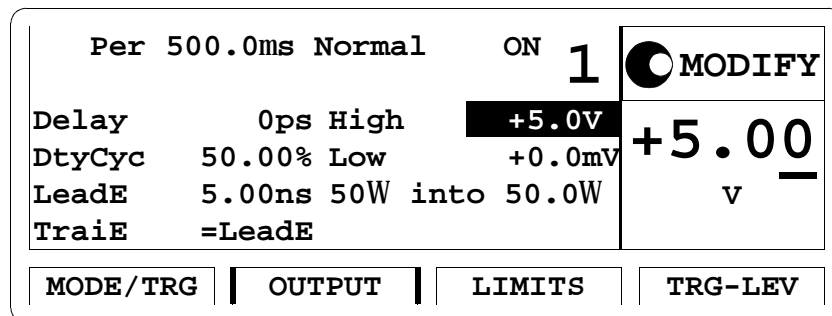

Configuring Output Screen

## Overshoot and Ringing

2. Set the digitizing oscilloscope Agilent 54121T:
  - Press AUTOSCALE
  - Select the Display menu and set the Number of Averages to 32
  - Select the Channel menu and set the Attenuation factor to 10
  - Center one pulse horizontally and vertically on screen
  - (e.g. TIME/DIV = 50 $\mu$ s/div, DELAY = 250  $\mu$ s)
  - Select the delta V menu and turn the voltage markers On
  - Set the VARIABLE LEVELS = 95% - 105% and press AUTO LEVEL SET
  - Select the channel menu and center vertically the top pulse (offset = 5 V)
  - Set the VOLTS/DIV = 200 mV/div

- Select the Timebase menu and set TIME/DIV = 5 ns/div, DELAY = 16 ns (>> 500 ns)
- 3. Set the Agilent 81101A to period = 500 ns
- 4. Check that Overshoot and Ringing are within the  $\pm 5\%$  of amplitude  $\pm 20$  mV window
- 5. Enter the result in the Test Report as TR entry 9 - 1

---

**NOTE:**

---

Take the oscilloscope's trace flatness error (GaAs input circuit) into account.

**Preshoot**

- 6. Set Agilent 81101A to:
  - Period = 500  $\mu$ s
  - High Level = 5 V
  - Low Level = 0 V
  - Delay = 10 ns
- 7. Set the digitizing oscilloscope, Agilent 54121T:
  - Press AUTOSCALE
  - Select the Display menu and set the Number of Averages to 32
  - Select the Channel menu and set the Attenuation factor to 10
  - Center one pulse horizontally and vertically on screen
  - (e.g. TIME/DIV = 50 $\mu$ s/div, DELAY = 265  $\mu$ s)
  - Select the delta V menu and turn the voltage markers On
  - Set the VARIABLE LEVELS = -5% to +5% and press AUTO LEVEL SET

## Agilent 81101A Performance Test

- Select the channel menu and center vertically the bottom of the pulse (offset = 0 V)
  - Set the VOLTS/DIV = 200 mV/div
  - Select the Timebase menu and set TIME/DIV = 5 ns/div, DELAY = 16 ns
8. Set Agilent 81101A to period = 500 ns
  9. Check that Preshoot is within the  $\pm 5\%$  of amplitude  $\pm 20$  mV window.
  10. Enter the result in the Test Report as TR entry 9 - 3



Agilent 81101A Performance Test

Test Equipment Used			
Description	Model No.	Trace No.	Cal. Due Date
1. Oscilloscope	Agilent 54121T	_____	_____
2. Counter	Agilent 5334B	_____	_____
3. Digital Voltmeter	Agilent 3458A	_____	_____
4. Pulse Generator	Agilent 8110A	_____	_____
5. Delay Line	Agilent 54008A	_____	_____
6.	_____	_____	_____
7.	_____	_____	_____
8.	_____	_____	_____
9.	_____	_____	_____
10.	_____	_____	_____
11.	_____	_____	_____
12.	_____	_____	_____
13.	_____	_____	_____
14.	_____	_____	_____

**Test Results for Agilent 81101A Mainframe**

Serial No. \_\_\_\_\_ Ambient temperature \_\_\_\_\_  
 °C

Customer \_\_\_\_\_ Relative humidity \_\_\_\_\_ %

CSO# \_\_\_\_\_ Line frequency \_\_\_\_\_ Hz

Tested by \_\_\_\_\_ Date \_\_\_\_\_

Comments

\_\_\_\_\_  
 \_\_\_\_\_  
 \_\_\_\_\_

**Internal Oscillator Period**

Scope Uncertainty factor \_\_\_\_\_

TR Entry	Test	Limit Min	Actual Result	Limit Max	Pass	Fail
1-1	20.0ns	19.000 ns	_____	21.000 ns	_____	_____
1-2	50.0ns	47.5 ns	_____	52.5 ns	_____	_____
1-3	99.9ns	94.905 ns	_____	104.895 ns	_____	_____

Agilent 81101A Performance Test

Counter Uncertainty factor \_\_\_\_\_

TR Entry	Test	Limit Min	Actual Result	Limit Max	Pass	Fail
1-6	100 ns	95.0ns	_____	105.0 ns	_____	_____
1-7	500 ns	475.0 ns	_____	525.0 ns	_____	_____
1-8	1 $\mu$ s	950.0 ns	_____	1050.0 ns	_____	_____
1-9	5 00 $\mu$ s	475 $\mu$ s	_____	5 25 $\mu$ s	_____	_____
1-10	500 ms	475 ms	_____	525 ms	_____	_____

**PLL Period**  
**(Results measured as frequency by counter)**

Counter Uncertainty factor \_\_\_\_\_

<b>TR Entry</b>	<b>Test</b>	<b>Limit Min</b>	<b>Actual Result</b>	<b>Limit Max</b>	<b>Pass</b>	<b>Fail</b>
2-1	20.00 ns	49.995MHz	_____	50.005 MHz	__	__
2-2	50.00 ns	19.9980MHz	_____	20.0020MHz	__	__
2-3	100 ns	9.9990MHz	_____	10.0010MHz	__	__
2-4	500 ns	1.9998MHz	_____	2.0002MHz	__	__
2-5	1 $\mu$ s	999.9 kHz	_____	1.0001 MHz	__	__
2-6	50 $\mu$ s	19.998 kHz	_____	20.002 kHz	__	__
2-7	5 ms	199.98 Hz	_____	200.02 Hz	__	__
2-8	500 ms	1.9998 Hz	_____	2.0002 Hz	__	__
2-9	5 s	0.19998 Hz	_____	0.20002 Hz	__	__

**Period Jitter**

Scope Uncertainty factor \_\_\_\_\_

<b>TR Entry</b>	<b>Test</b>	<b>Limit Min</b>	<b>Actual Result</b>	<b>Limit Max</b>	<b>Pass</b>	<b>Fail</b>
6.1a-1	50 ns		_____	20 ps	_____	_____
6.1a-2	500 ns		_____	65 ps	_____	_____
6.1b-1	20 ns		_____	15.2 ps	_____	_____

**Test Results for Agilent 81101A Output Channel**

**Width**

Scope Uncertainty factor \_\_\_\_\_

TR Entry	Test	Limit Min	Actual Result	Limit Max	Pass	Fail
3-1	10.0 ns	9.250ns	_____	10.750 ns	_____	_____
3-2	50.0 ns	47.25 ns	_____	52.75 ns	_____	_____
3-3	100 ns	94.75 ns	_____	105.25 ns	_____	_____
3-4	500 ns	474.75 ns	_____	525.25 ns	_____	_____
3-5	50 $\mu$ s	47.5 $\mu$ s	_____	52.5 $\mu$ s	_____	_____
3-6	5 ms	4.75 ms	_____	5.25 ms	_____	_____
3-7	500 ms	475 ms	_____	525 ms	_____	_____

**Width Jitter**

Scope Uncertainty factor \_\_\_\_\_

TR Entry	Test	Limit Min	Actual Result	Limit Max	Pass	Fail
6.2-1	50 ns		_____	20 ps	_____	_____
6.2-2	500 ns		_____	65 ps	_____	_____

**Delay**

Scope Uncertainty factor \_\_\_\_\_

TR Entry	Test	Limit Min	Actual Result	Limit Max	Pass	Fail
4-1	0.00 ns		_____	Fixed Delay	_____	_____
4-2	5.00 ns	3.75 ns	_____	6.25 ns	_____	_____
4-3	10 ns	8.50 ns	_____	11.50 ns	_____	_____
4-4	50.0 ns	46.5 ns	_____	53.5 ns	_____	_____
4-5	100 ns	94.0 ns	_____	106.0 ns	_____	_____
4-6	500 ns	474.0 ns	_____	526.0 ns	_____	_____
4-7	50 $\mu$ s	47.5 $\mu$ s	_____	52.5 $\mu$ s	_____	_____
4-8	5 ms	4.75 ms	_____	5.25 ms	_____	_____
4-9	500 ms	475 ms	_____	525 ms	_____	_____

**Delay Jitter**

Scope Uncertainty factor \_\_\_\_\_

TR Entry	Test	Limit Min	Actual Result	Limit Max	Pass	Fail
6.3-1	50 ns		_____	20 ps	_____	_____
6.3-2	500 ns		_____	65 ps	_____	_____

**Double Pulse Delay**

Scope Uncertainty factor \_\_\_\_\_

TR Entry	Test	Limit Min	Actual Result	Limit Max	Pass	Fail
5-1	20.0 ns	18.50 ns	_____	21.50 ns	_____	_____
5-2	50.0ns	47.00 ns	_____	53.00 ns	_____	_____
5-3	100ns	94.50 ns	_____	105.50 ns	_____	_____

Counter Uncertainty factor \_\_\_\_\_

TR Entry	Test	Limit Min	Actual Result	Limit Max	Pass	Fail
5-4	500 ms	475 ms	_____	525 ms	_____	_____
5-5	1 s	950.0 ms	_____	1050.0 ms	_____	_____

**High Level 50Ω-50Ω**

TR Entry	Test	Limit Min	Actual Result	Limit Max	Pass	Fail
7.1-1	10.0 V	9.625 V	_____	10.375 V	_____	_____
7.1-2	5.0 V	4.775 V	_____	5.225 V	_____	_____
7.1-3	3.0V	2.845 V	_____	3.165 V	_____	_____
7.1-4	1.0 V	0.895 V	_____	1.105 V	_____	_____
7.1-5	0.5 V	410 mV	_____	590 mV	_____	_____
7.1-6	0.1 V	22 mV	_____	178 mV	_____	_____

**High Level 1KΩ–50Ω**

TR Entry	Test	Limit Min	Actual Result	Limit Max	Pass	Fail
7.3-1	19.0 V	17.90V	_____	20.10 V	_____	_____
7.3-2	10.0 V	9.35 V	_____	10.65 V	_____	_____
7.3-3	5.0 V	4.60 V	_____	5.40 V	_____	_____
7.3-4	1.0 V	0.80 V	_____	1.20V	_____	_____
7.3-5	0.2 V	40 mV	_____	360mV	_____	_____

**Low Level 50Ω-50Ω**

TR Entry	Test	Limit Min	Actual Result	Limit Max	Pass	Fail
7.2-1	-0.1 V	-22 mV	_____	-178 mV	_____	_____
7.2-2	-0.5 V	-410 mV	_____	-590 mV	_____	_____
7.2-3	-1.0 V	-0.895 V	_____	-1.105 V	_____	_____
7.2-4	-3.0V	-2.845 V	_____	-3.165 V	_____	_____
7.2-5	-5.0V	-4.775 V	_____	-5.225 V	_____	_____
7.2-6	-10.0V	-9.625 V	_____	-10.375 V	_____	_____

**Low Level 1KΩ-50Ω**

TR Entry	Test	Limit Min	Actual Result	Limit Max	Pass	Fail
7.4-1	-0.2V	-40 mV	_____	-360 mV	_____	_____
7.4-2	-1.0V	-0.80 V	_____	-1.20 V	_____	_____
7.4-3	-5.0V	-4.60V	_____	-5.40 V	_____	_____
7.4-4	-10.0V	-9.350 V	_____	-10.650 V	_____	_____
7.4-5	-19.0V	-17.90 V	_____	-20.10 V	_____	_____

**Leading Edge**

Scope Uncertainty factor \_\_\_\_\_

TR Entry	Test	Limit Min	Actual Result	Limit Max	Pass	Fail
8.1a-1	5.0 ns	≤5 ns	_____	5.7 ns	_____	_____
8.1a-2	10 ns	8.8 ns	_____	11.2 ns	_____	_____
8.1a-3	50 ns	44.8 ns	_____	55.2 ns	_____	_____
8.1a-4	500 ns	449.8 ns	_____	550.2 ns	_____	_____
8.1a-5	5 μs	4.4998 μs	_____	5.5002 μs	_____	_____
8.1a-6	50 μs	45 μs	_____	55 μs	_____	_____
8.1a-7	500 μs	450 μs	_____	550 μs	_____	_____
8.1a-8	50 ms	45 ms	_____	55 ms	_____	_____

**Trailing Edge**

TR Entry	Test	Limit Min	Actual Result	Limit Max	Pass	Fail
8.1b-1	5.0 ns	≤5 ns	_____	5.7 ns	_____	_____
8.1b-2	10 ns	8.8 ns	_____	11.2 ns	_____	_____
8.1b-3	50 ns	44.8 ns	_____	55.2ns	_____	_____
8.1b-4	500 ns	449.8 n	_____	550.2 ns	_____	_____
8.1b-5	5 μs	4.4998 μs	_____	5.5002 μs	_____	_____
8.1b-6	50 μs	45 μs	_____	55 μs	_____	_____
8.1b-7	500 μs	450 μs	_____	550 μs	_____	_____
8.1b-8	50 ms	45 ms	_____	55 ms	_____	_____

**Overshoot and Ringing**

Scope Uncertainty factor \_\_\_\_\_

TR Entry	Test	Limit Min	Actual Result	Limit Max	Pass	Fail
9-1	5V		_____	$\pm 5\%$ of ampl. $\pm 20\text{mV}$	_____	_____
9-2	500 mV		_____	$\pm 5\%$ of ampl. $\pm 20\text{mV}$	_____	_____

**Preshoot**

TR Entry	Test	Limit Min	Actual Result	Limit Max	Pass	Fail
9-3	0 V		_____	$\pm 5\%$ of ampl. $\pm 20\text{mV}$	_____	_____

Publication Number: 5988-4851EN

