

Keysight PSG Signal Generators

E8257D/67D, E8663D

Notice: This document contains references to Agilent. Please note that Agilent's Test and Measurement business has become Keysight Technologies. For more information, go to www.keysight.com.

Notices

© Keysight Technologies 2006-2014

No part of this manual may be reproduced in any form or by any means (including electronic storage and retrieval or translation into a foreign language) without prior agreement and written consent from Keysight Technologies, Inc. as governed by United States and international copyright laws.

Manual Part Number

E8251-90359

Edition

December 2014

Published in USA

Keysight Technologies
1400 Fountaingrove Pkwy.
Santa Rosa, CA 95403 USA

Warranty

THE MATERIAL CONTAINED IN THIS DOCUMENT IS PROVIDED "AS IS," AND IS SUBJECT TO BEING CHANGED, WITHOUT NOTICE, IN FUTURE EDITIONS. FURTHER, TO THE MAXIMUM EXTENT PERMITTED BY APPLICABLE LAW, KEYSIGHT DISCLAIMS ALL WARRANTIES, EITHER EXPRESS OR IMPLIED WITH REGARD TO THIS MANUAL AND ANY INFORMATION CONTAINED HEREIN, INCLUDING BUT NOT LIMITED TO THE IMPLIED WARRANTIES OF MERCHANTABILITY AND FITNESS FOR A PARTICULAR PURPOSE. KEYSIGHT SHALL NOT BE LIABLE FOR ERRORS OR FOR INCIDENTAL OR CONSEQUENTIAL DAMAGES IN CONNECTION WITH THE FURNISHING, USE, OR PERFORMANCE OF THIS DOCUMENT OR ANY INFORMATION CONTAINED HEREIN. SHOULD KEYSIGHT AND THE USER HAVE A SEPARATE WRITTEN AGREEMENT WITH WARRANTY TERMS COVERING THE MATERIAL IN THIS DOCUMENT THAT CONFLICT WITH THESE TERMS, THE WARRANTY TERMS IN THE SEPARATE AGREEMENT WILL CONTROL.

Technology Licenses

The hardware and/or software described in this document are furnished under a license and may be used or copied only in accordance with the terms of such license.

Restricted Rights Legend

U.S. Government Restricted Rights. Software and technical data rights granted to the federal government include only those rights customarily provided to end user customers. Keysight provides this customary commercial license in Software and technical

data pursuant to FAR 12.211 (Technical Data) and 12.212 (Computer Software) and, for the Department of Defense, DFARS 252.227-7015 (Technical Data - Commercial Items) and DFARS 227.7202-3 (Rights in Commercial Computer Software or Computer Software Documentation).

Safety Notices

CAUTION

A CAUTION notice denotes a hazard. It calls attention to an operating procedure, practice, or the like that, if not correctly performed or adhered to, could result in damage to the product or loss of important data. Do not proceed beyond a CAUTION notice until the indicated conditions are fully understood and met.

WARNING

A WARNING notice denotes a hazard. It calls attention to an operating procedure, practice, or the like that, if not correctly performed or adhered to, could result in personal injury or death. Do not proceed beyond a WARNING notice until the indicated conditions are fully understood and met.

Table of Contents

1. Troubleshooting

Electrostatic Discharge (ESD) Information	2
Handling of Electronic Components and ESD	3
Getting Started with Troubleshooting	4
Running Self-Test	4
A18 CPU Turn-On Test	6
Failure Symptoms	6
A2 Display Not Functioning or A2 Display Not Functioning After Turn-on	6
A18 CPU Fails to Complete the Turn-On Check	6
Checking the A18 CPU Voltages	7
Verifying the A18 CPU Turn-On Sequence	7
No Instrument Control From the Front Panel	8
Error Messages	8
CPU Data Backup	8
Self-Test Failures and Related Troubleshooting	9
Troubleshooting Assembly-Level Problems	14
Front-Panel Display Assembly Troubleshooting	14
Power Supply Troubleshooting	21
Option 008/009 Troubleshooting	38
Self-Tests 1xx for the A13 I/Q Multiplexer	39
Self-Tests 2xx: A5 Sampler Self-Test Errors	42
Self-Tests 3xx: A7 Reference (Standard) Self-Test Errors (For instruments with serial prefixes < US4805/MY4805)	44
Self-Tests 4xx: A8 Output Self-Test Errors (E8267D only)	45
Self-Tests 6xx: A9 YIG Driver Self-Test Errors	48
Self-Tests 7xx: A6 Frac-N Self-Test Errors	51
Self-Tests 7xx: A45 Frac-N Self-Test Errors (option UNY)	54
Self-Tests 9xx: A10 ALC Self-Test Errors	55
Self-Tests 10xx: A7 Reference (Option UNR/UNIX and Instruments with Serial Prefixes >= US4805/MY4805) Self-Test Errors	58
Self-Tests 11xx: A18 CPU Self-Test Errors	60
Self-Tests 12xx: A26 MID Self-Test Errors (E8257D)	61
Self-Tests 12xx: A26 MID Self-Test Errors (E8267D)	67
Self-Tests 13xx: A11 Analog/Pulse Modulation Generator Self-Test Errors	73
Self-Tests 16xx for the A14 Baseband Generator (Option 601/602)	76
Self-Tests 22xx: A8 Output Self-Test Errors	79
Self-Tests 24xx: A38 Lowband Filter Self-Test Errors	81
Self-Tests 25xx: A43 Amp Filter Self-Test Errors	82
Self-Tests 26xx: A8 Output Self-Test Errors	84
Self-Tests 27xx: A46 Offset Loop Self-Test Errors (Option UNY)	86
Self-Tests 28xx: A8 Vector Output Self-Test Errors	86
Troubleshooting Unlocks	88
508 A6 Frac-N Loop Unlock	88
512 A7 Reference Unlock	89
513 1 GHz Out of Lock	89

Contents

514 Reference Oven Cold	89
515 10 MHz Signal Bad	90
520 Sampler Unlocked	90
521 YO Loop Unlocked	90
625 Internal Pulse Generator Unlock	91
626 Internal Mod Source Unlock	91
Troubleshooting Unlevels	92
Troubleshoot and correct any unlock problems before troubleshooting unlevelled problems.	92
Troubleshooting Adjustment Problems	100
Troubleshooting ADC Adjustment Failures	103
Troubleshooting Performance Test Problems	104
Troubleshooting the RF Path	106
Troubleshooting RF Power Levels.	106
ALC and RF problems	106
Troubleshooting Pulse Modulation.	108
Troubleshooting AT1 Attenuator.	109
Troubleshooting Harmonic Spurious	111
20 GHz Models	111
20 GHz Models	112
32 GHz and 44 GHz Models Only	113
40 GHz Models Only	113
50 and 67 GHz Models Only	114
Troubleshooting Non-Harmonic Spurious.	116
Troubleshooting Option UNR/UNX/UNY and Instruments with Serial Prefixes ³ US4805/MY4805 Phase Noise	117
Overall Description	118
A18 CPU	118
A19 Power Supply	118
Input/Output Interface	119
Frequency Generation.	120
Overall PSG Analog Signal Generator	127
Overall PSG Vector Signal Generator	129
Reference/Synthesis Loop Description	131
A5 Sampler (CW mode only).	133
A6 Frac-N	133
A7 Reference	134
A9 YIG Driver	135
A28 YIG Oscillator (YO).	136
A29 20 GHz Doubler	136
A38 Switch Filter and A43 Lowband Amp Filter (Option 1EH)	136
Reference/Synthesis Loop	137
RF Path Description (Frequency Generation, Level Control, and Modulation)	139
A6 Frac-N	140
A8 Output	141
A12 <3.2 GHz Fast Pulse Modulator (Option UNW)	141
A23 Lowband Coupler/Detector, A24 Highband Coupler, and A25 High Band Detector	142

A27 40 GHz Doubler (Analog 40 GHz Models and Vector 44 GHz Models)	142
A29 20 GHz Doubler	142
A30 Modulation Filter	143
A35 3–20 GHz I/Q Modulator (Vector Models Only)	143
A36 Quadraplier (Analog Models > 40 GHz)	144
A37 44 GHz Upconverter (Vector Models > 20 GHz)	144
ALC Loop	145
Modulation (Option UNT–AM, FM, Φ M, UNU–Standard Pulse, and UNW–Fast Pulse)	146
Digital Modulation	147
Approximate Device Gains and Losses	149
Analog RF Path Block Diagram (1 of 2)	151
Analog RF Path Block Diagram (2 of 2)	153
Analog Low Band RF Path Block Diagram	155
Analog and Vector Option UNY Block Diagram	157
Vector RF Path Block Diagram (1 of 2)	159
Vector RF Path Block Diagram (2 of 2)	161
Vector Low Band RF Path	163
Self–Test Overview	165
How self–test works:	165
Independent failures	165
Contacting Keysight Technologies	167
Keysight Sales and Service Offices	169
Packaging a Signal Generator for Return	169
2. Replaceable Parts	
Ordering Information	1
Order Parts Fast	1
Frequency, Hardware, and Personality Options	2
Assemblies	4
Assemblies from the Inside Front Panel View	9
Assemblies from a Top View	11
Assemblies from a Microcircuit Deck View	16
Assemblies from a Bottom View	19
A18BT1 Lithium Battery	21
Cables	22
Hardware	40
Front Panel View	41
Disassembled Front Panel View	43
Disassembled Rear Panel View	45
Disassembled A32 10 MHz Crystal Oscillator (Option UNR/UNX/UNY and Instruments with Serial Prefixes >= US4805/MY4805)	48
Disassembled AT1 90dB/115dB Attenuator View (Option 1E1)	50
Disassembled A24 20GHz/40GHz Highband Coupler and A25B Highband Detector Bias Board (Options 503, 509, 520, and 540)	51
Disassembled A24 20GHz Highband Coupler and A25B Highband Detector Bias Board (Option 521)	52
Disassembled A24 50GHz Highband Coupler and A25B Highband Detector Bias Board	53

Contents

Disassembled A24 67GHz Highband Coupler and A25B Highband Detector Bias Board	54
Microcircuit Interface Deck Top View	55
Main Chassis and MID Bottom View	56
1.85 mm RF Output Connector (Option 567 Only)	59
2.4 mm RF Output Connector	60
APC 3.5 RF Output Connector (Option 520 Only)	61
Type-N RF Output Connector (Option 1ED Models Only)	62
Main Chassis with Inside Cover and Right-Side Support Wall	63
Outer and Inner Instrument Covers and Associated Parts	65
Miscellaneous	67
Accessories	67
Documentation	67
Electrostatic Discharge (ESD) Protective Supplies	68
Abbreviations Used in Part Descriptions	69

3. Assembly Replacement

Before You Replace an Assembly	1
After Replacing or Repairing an Assembly	1
Assemblies That You Can Replace	2
Outer Instrument Cover	6
Tools Required	6
Removal Procedure	6
Replacement Procedure	6
Inner Instrument Cover	8
Tools Required	8
Removal Procedure	8
Replacement Procedure	8
Front Panel	10
Tools Required	10
Removal Procedure	10
Replacement Procedure	12
A1 Keyboard	14
Tools Required	14
Removal Procedure	14
Replacement Procedure	14
A2 Display	17
Tools Required	17
Removal Procedure	17
Replacement Procedure	17
A2DS1 Display Backlight (serial number prefix < US/MY5XXX3XXX only)	20
Tools Required	20
Removal Procedure	20
Replacement Procedure	20
A3 Power Switch	22
Tools Required	22
Removal Procedure	22
Replacement Procedure	22

A4 Inverter (serial number prefix < US/MY5XXX3XXX only)	25
Tools Required	25
Removal Procedure	25
Replacement Procedure	25
A5 Sampler, A6 Frac-N, A7 Reference (Standard and Option UNR/UNX/UNY), A8 Output, A45 Frac-N and A46 Offset	27
Tools Required	27
Removal Procedure	27
Replacement Procedure	27
A9 YIG Driver	29
Tools Required	29
Removal Procedure	29
Replacement Procedure	29
A10 ALC	31
Tools Required	31
Removal Procedure	31
Replacement Procedure	31
A11 Pulse/Analog Modulation Generator	33
Tools Required	33
Removal Procedure	33
Replacement Procedure	33
A12 Pulse Modulator Board	35
Tools Required	35
Removal Procedure	35
Replacement Procedure	35
A13 I/Q MUX (E8267D Standard or with Option 015) (Serial Prefixes <US4722/MY4722)	37
Tools Required	37
Removal Procedure	37
Replacement Procedure	37
A13 I/Q MUX (E8267D Standard or with Option H16/016) (Serial Prefixes >=US4722/MY4722)	39
Tools Required	39
Removal Procedure	39
Replacement Procedure	40
A14 Baseband Generator (E8267D Only)	41
Tools Required	41
Removal Procedure	41
Replacement Procedure	41
A17 Baseband Generator Interface (E8267D Only)	43
Tools Required	43
Removal Procedure	43
Replacement Procedure	43
A18 CPU	45
Tools Required	45
Removal Procedure	45
Replacement Procedure	45
A18BT1	47
Tools Required	47

Contents

Removal Procedure	47
Replacement Procedure	47
A19 Power Supply	49
Tools Required	49
Removal Procedure	49
Replacement Procedure	50
A20 SMI (Source Module Interface)	52
Tools Required	52
Removal Procedure	52
Replacement Procedure	52
A21 Rear-Panel Interface	54
Tools Required	54
Removal Procedure	54
Replacement Procedure	54
A22 Line Module	56
Tools Required	56
Removal Procedure	56
Replacement Procedure	56
A23 Lowband Coupler/Detector	58
Tools Required	58
Removal Procedure	58
Replacement Procedure	58
A24 20 GHz Highband Coupler (Options 503, 509, 520, and 521)	60
Tools Required	60
Removal Procedure	60
Replacement Procedure	61
A24 40 GHz Highband Coupler (Option 540)	65
Tools Required	65
Removal Procedure	65
Replacement Procedure	65
A24 50 GHz Highband Coupler (Options 532 and 544)	67
Tools Required	67
Removal Procedure	67
Replacement Procedure	67
A24 67 GHz Highband Coupler (Options 550 and 567)	69
Tools Required	69
Removal Procedure	69
Replacement Procedure	69
A25 20 GHz Highband Detector (Options 503, 509, 520, & 521)	71
Tools Required	71
Removal Procedure	71
Replacement Procedure	71
A25 40 GHz Highband Detector (Option 540)	74
Tools Required	74
Removal Procedure	74
Replacement Procedure	74
A25 50 GHz Highband Detector (Options 532 and 544)	76

Tools Required	76
Removal Procedure	76
Replacement Procedure	76
A25 67 GHz Highband Detector (Options 550 and 567)	78
Tools Required	78
Removal Procedure	78
Replacement Procedure	78
A25B Highband Detector Bias Board	80
Tools Required	80
Removal Procedure	80
Replacement Procedure	80
A26 MID (Microcircuit Interface Deck)	82
Tools Required	82
Removal Procedure	82
Replacement Procedure	83
A27 40 GHz Doubler (Option 540)	85
Tools Required	85
Removal Procedure	85
Replacement Procedure	85
A27 40 GHz Doubler (Options 532 and 544 only)	87
Tools Required	87
Removal Procedure	87
Replacement Procedure	87
A28 YIG Oscillator	89
Tools Required	89
Removal Procedure	89
Replacement Procedure	89
A29 20 GHz Doubler	91
Tools Required	91
Removal Procedure	91
Replacement Procedure	91
A30 Modulation Filter (Standard and Option 1EA/1EU)	93
Tools Required	93
Removal Procedure	93
Replacement Procedure	94
A31 Motherboard (E8257D & E8663D)	96
Tools Required	96
Removal Procedure	96
Replacement Procedure	97
A31 Motherboard (E8267D)	99
Tools Required	99
Removal Procedure	99
Replacement Procedure	100
A32 10 MHz Crystal Oscillator	102
Tools Required	102
Removal Procedure	102
Replacement Procedure	102

Contents

A33 6dB PAD (Options 503, 509, 520, and 521)	104
Tools Required	104
Removal Procedure	104
Replacement Procedure	104
A33 10dB PAD (Options 532 and 544)	106
Tools Required	106
Removal Procedure	106
Replacement Procedure	106
Rear Panel (Standard)	108
Tools Required	108
Removal Procedure	108
Replacement Procedure	109
Rear Panel (Option 1EM)	111
Tools Required	111
Removal Procedure	111
Replacement Procedure	113
A34 Internal Hard Drive (E8267D Only - Discontinued)	115
Tools Required	115
Removal Procedure	115
Replacement Procedure	115
A35 3–20 GHz I/Q Modulator (E8267D Only - Standard or with Option 015)	117
Tools Required	117
Removal Procedure	117
Replacement Procedure	117
A35 3–20 GHz I/Q Modulator (E8267D Only - Standard or with Option H16/016) (Serial Prefixes >=US4722/MY4722)	119
Tools Required	119
Removal Procedure	119
Replacement Procedure	119
A36 Quadraplier (Options 550 and 567)	121
Tools Required	121
Removal Procedure	121
Replacement Procedure	121
A37 Upconverter (E8267D Only)	123
Tools Required	123
Removal Procedure	123
Replacement Procedure	123
A38 Lowband Switch Filter	125
Tools Required	125
Removal Procedure	125
Replacement Procedure	125
A39 Directional Sweep Coupler	127
Tools Required	127
Removal Procedure	127
Replacement Procedure	127
A40 Compact Flash Drive Assembly	129
Tools Required	129

Removal Procedure	129
Replacement Procedure	129
A41 Flash Drive Door Assembly	131
Tools Required	131
Removal Procedure	131
Replacement Procedure	131
A42 20 GHz Power Amp (Option 521)	133
Tools Required	133
Removal Procedure	133
Replacement Procedure	133
A43 Lowband Amp Filter	135
Tools Required	135
Removal Procedure	135
Replacement Procedure	135
A44 Scan Modulation Bias Adapter (E8257D-520 and E8663D Only)	137
Tools Required	137
Removal Procedure	137
Replacement Procedure	137
AT1 90 dB Attenuator	139
Tools Required	139
Removal Procedure	139
Replacement Procedure	139
AT1 115 dB Attenuator	141
Tools Required	141
Removal Procedure	141
Replacement Procedure	141
AT1 90 dB Attenuator (Option 1EM)	143
Tools Required	143
Removal Procedure	143
Replacement Procedure	143
AT1 115 dB Attenuator (Option 1EM)	145
Tools Required	145
Removal Procedure	145
Replacement Procedure	145
B1 Fan	147
Tools Required	147
Removal Procedure	147
Replacement Procedure	147
4. Post–Repair Procedures	
Post–Repair Procedures Matrix	2
CPU Configuration	16
5. Safety and Regulatory	
General Safety Considerations	2
Lithium Battery Disposal	4

Contents

Assistance 4
Certification 4

Documentation Overview

- Installation Guide**
 - Safety Information
 - Getting Started
 - Operation Verification
 - Regulatory Information

- User's Guide**
 - Signal Generator Overview
 - Basic Operation
 - Basic Digital Operation
 - Optimizing Performance
 - Analog Modulation
 - Custom Arb Waveform Generator
 - Custom Real Time I/Q Baseband
 - GPS Modulation (Option 409)
 - Multitone Waveform Generator
 - Two-Tone Waveform Generator
 - AWGN Waveform Generator
 - Peripheral Devices
 - Troubleshooting

- Programming Guide**
 - Getting Started with Remote Operation
 - Using IO Interfaces
 - Programming Examples
 - Programming the Status Register System
 - Creating and Downloading Files
 - Creating and Downloading User-Data Files

- SCPI Reference**
 - Using this Guide
 - System Commands
 - Basic Function Commands
 - Analog Commands
 - Digital Modulation Commands
 - Digital Signal Interface Module Commands
 - SCPI Command Compatibility

- Programming Compatibility Guide** – Provides a listing of SCPI commands and programming codes for signal generator models that are supported by the Keysight N5171B/72B EXG and N5181B/82B MXG X-Series signal generators.

- Service Guide** –
 - Troubleshooting
 - Replaceable Parts
 - Assembly Replacement
 - Post-Repair Procedures
 - Safety and Regulatory Information

- Key Help^a** – Key function description

a. Press the Help hardkey, and then the key for which you wish help.

1 Troubleshooting

- “Electrostatic Discharge (ESD) Information” on page 2
- “Getting Started with Troubleshooting” on page 4
- “A18 CPU Turn-On Test” on page 6
- “Self-Test Failures and Related Troubleshooting” on page 9
- “Troubleshooting Assembly-Level Problems” on page 14
- “Troubleshooting Unlocks” on page 88
- “Troubleshooting Unlevels” on page 92
- “Troubleshooting Adjustment Problems” on page 100
- “Troubleshooting ADC Adjustment Failures” on page 103
- “Troubleshooting Performance Test Problems” on page 104
- “Troubleshooting the RF Path” on page 106
- “Troubleshooting Harmonic Spurious” on page 111
- “Troubleshooting Non-Harmonic Spurious” on page 116
- “Troubleshooting Option UNR/UNX/UNY and Instruments with Serial Prefixes ³ US4805/MY4805 Phase Noise” on page 117
- “Overall Description” on page 118
- “Reference/Synthesis Loop Description” on page 131
- “RF Path Description (Frequency Generation, Level Control, and Modulation)” on page 139
- “Self-Test Overview” on page 165
- “Contacting Keysight Technologies” on page 167

WARNING

Troubleshooting instructions are for use by qualified personnel only. To avoid electrical shock, do not perform any troubleshooting unless qualified.

The opening of covers or removal of parts is likely to expose dangerous voltages. Disconnect the signal generator from all voltage sources before it is opened.

Electrostatic Discharge (ESD) Information

WARNING The following techniques related to ESD and static-safe workstations should not be used when working on circuitry with a voltage potential greater than 500 volts.

ESD can damage or destroy electronic components. All work on electronic assemblies should be performed at a static-safe workstation using two types of static-safe workstation protection:

- conductive table-mat and wrist-strap combination
- conductive floor-mat and heel-strap combination

Both types, when used together, provide a significant level of ESD protection. Of the two, only the table-mat and wrist-strap combination provides adequate ESD protection when used alone. To ensure user safety, the static-safe accessories must provide at least 1 M Ω of isolation from ground.

Handling of Electronic Components and ESD

CAUTION

Many of the assemblies in this instrument are very susceptible to damage from ESD. Perform troubleshooting procedures only at a static-safe workstation, and wear a grounding strap.

Always handle a printed circuit board assembly by its edges. This reduces the possibility of ESD damage to components, and prevent contamination of exposed plating.

The possibility of unseen damage caused by ESD is present whenever components are transported, stored, or used. The risk of ESD damage can be greatly reduced by close attention to how all components are handled.

- Perform work on all components at a static-safe workstation.
- Keep static-generating materials at least one meter away from all components.
- Store or transport components in static-shielding containers.

Getting Started with Troubleshooting

Referring to **Table 1-1**:

- determine where to begin troubleshooting
- work on problems in the order they are presented in the table
- use the descriptions provided in this chapter that explain how the signal generator operates, and the function of each assembly: the overall description ([page 1-118](#)), the synthesis loop ([page 1-131](#)), the RF path ([page 1-139](#)), and self-test ([page 1-165](#)).

Table 1-1

If able to run self-test...	Go to this section...
Run Self-Test	"Running Self-Test" on page 4 and refer to "Self-Test Failures and Related Troubleshooting" on page 9.
If unable to run self-test, check...	Go to this section...
Power supply failures A18 CPU turn-on failures Front panel display or keyboard operations	"Power Supply Troubleshooting" on page 21 "A18 CPU Turn-On Test" on page 6 "Front-Panel Display Assembly Troubleshooting" on page 14
If other conditions occur...	Go to this section...
Unlocked Conditions Unleveled Conditions Adjustment Problems Performance Test Problems	"Troubleshooting Unlocks" on page 88 "Troubleshooting Unlevels" on page 92 "Troubleshooting Adjustment Problems" on page 100 "Troubleshooting Performance Test Problems" on page 104

Running Self-Test

NOTE

A bad assembly can cause other assemblies to fail. The internal failure tree will identify the most likely failed assembly and report it as the "most independent failure." Troubleshoot and replace that assembly before troubleshooting and replacing other assemblies.

When you replace an assembly a good assembly will pass self-test without any adjustments.

1. On the instrument front panel, press the **Utility** hardkey.
2. Select the following softkeys:
 - a. **Instrument Info/Help Mode**
 - b. **Self Test**
 - c. **Run Complete Self Test**
3. When the Self-Test finishes, one of the following messages displays:
 - If the Self Test passed: “The current status of self test is: Success All self tests have passed.”
 - If the Self-Test failed: “The current status of self test is: Failed.” The message also reports the most independent failure.
4. If the Self-Test failed, look up the reported most independent failure in the **“Self-Test Failures and Related Troubleshooting”** section on **page 9**.
5. Troubleshoot and repair the most independent failure.
6. After you replace the failed assembly, run the Self-Test again.
7. If another assembly is reported as the most independent failure, repeat steps 4 thru 6 until the Self-Test passes.

A18 CPU Turn-On Test

NOTE If it is determined that the A18 CPU is defective but still functions, it is recommended that you back up the calibration data in the CPU prior to replacing it. To back up the calibration data, see [“CPU Data Backup” on page 8](#).

At turn-on, the A18 CPU is designed to complete a series of operational checks. If all power supply voltages are present and the A18 CPU is working correctly, the operational checks are completed. Errors are reported if the A18 CPU has problems identifying other assemblies or communicating with the backup memory located on the A31 Motherboard.

Failure Symptoms

- display is not functioning
- CPU fails to complete the turn-on check and does not reach normal LCD operation
- display is not functioning after turn-on
- unable to control signal generator from front panel
- error message is displayed after turn-on

A2 Display Not Functioning or A2 Display Not Functioning After Turn-on

Refer to [“Front-Panel Display Assembly Troubleshooting” on page 14](#).

A18 CPU Fails to Complete the Turn-On Check

1. Turn power off and remove outer and inner covers.
2. Turn on power and verify A18 CPU LED DS9 (+3.4 Vdc) and DS10 (+5.2 Vdc) are on. If either of the LEDs are off, check the voltages in [Table 1-2](#). Refer to the illustration in [“Self-Tests 11xx: A18 CPU Self-Test Errors” on page 60](#) for LED locations.

Table 1-2

Connector P222 (A31 Motherboard)	Supply Voltage	Acceptable Range
Pin 45-48, 95-98	+3.4 Vdc	+3.4 ± 0.07 Vdc
Pin 49, 50, 99, 100	+5.2 Vdc	+5.2 ± 0.1 Vdc

3. If the voltages are present on connector P222, turn power off and remove the A18 CPU.
4. Inspect the pins on the A31 Motherboard connector. If the pins look good replace the A18 CPU.
5. If either of the voltages are missing, refer to **“Power Supply Troubleshooting” on page 21**.
6. If DS9 and DS10 are on, proceed to **“Checking the A18 CPU Voltages” on page 7**.

Checking the A18 CPU Voltages

1. With the external and internal covers removed and the signal generator on its side, turn power on and check to see if all the power supply LEDs on the A31 Motherboard are on. If any of the power supply LEDs are not on, refer to **“Power Supply Troubleshooting” on page 21** to troubleshoot.
2. If all the power supply LEDs on the motherboard are on, check the A18 CPU and A31 Motherboard connector pins for the voltages listed in the following table.

Connector	Supply Voltage	Acceptable Range
P223-2, 22	+5 VA	+5.2 ± 0.16 Vdc
P223-3	-15 V_In	-15 ± 0.45 Vdc
P223-4	+32 V_In	+32 ± 0.96 Vdc
P223-21	+15 V_Standby	+14.85 ± 0.6 Vdc
P223-23	+15 V_In	+15 ± 0.75 Vdc
P223-37	-7 Vdc	-7.0 ± 0.14 Vdc
P223-39	+10 Vdc	+10.2 ± 0.2 Vdc
P223-40	+8 Vdc	+7.95 ± 0.21 Vdc

3. If any main power supply voltage problems are detected, refer to **“Power Supply Troubleshooting” on page 21**.
4. If all power supply voltages are good, replace A18 CPU.

Verifying the A18 CPU Turn-On Sequence

Verify the A18 CPU turn-on sequence by observing DS1 to DS8 sequence patterns (See the diagram on **page 60** for LED locations). DS1 to DS8 should match the sequence shown in **Table 1-3**. Before verifying the turn-on

sequence, make sure all switches in the upper left-hand corner of the A18 CPU are in the CLOSED (up) position. If the lights fail to step through the sequence, replace A18 CPU.

Table 1-3 A18 CPU LED Sequence Table

Sequence	DS1	DS2	DS3	DS4	DS5	DS6	DS7	DS8
1	X	X	X	X	X	X	X	X
2	0	0	X	0	0	0	0	0
3	X	X	X	0	0	0	0	0
4	0	X	X	X	X	X	X	X
5	0	0	0	0	0	0	0	0
6	X	X	X	X	X	X	X	0

X = LED is on; 0 = LED is off

No Instrument Control From the Front Panel

Refer to **“Front-Panel Display Assembly Troubleshooting”** on page 14.

Error Messages

If error messages are reported after the turn-on check is completed, refer to the **Error Messages** list, located on the E8257D/67D PSG Signal Generator Documentation Set CD (part number E8251-90351) for details.

CPU Data Backup

This procedure applies only if the CPU is working prior to removal.

1. Record the installed license keys:

- a. Press **Utility > Instrument Adjustments > Instrument Options > Software Options**.
- b. For each option that has a check mark after the license key, write down the option number and the license key.

Take your time to be sure that you record each license key correctly.

2. Backup the calibration data from the CPU to the mother board:

- Execute the SCPI command: `:DIAG:FILE:BACK`.

3. Follow the instructions from **Chapter 3, “Assembly Replacement.”** to replace the CPU board.

Self-Test Failures and Related Troubleshooting

NOTE Self-test results are valid only when all external cables and connectors are removed from the PSG.

Table 1-4 Self-test Failures and Related Troubleshooting

If this self-test fails...	Go to this troubleshooting section...
A13 I/Q Multiplexer 100 Power Supply 101 CAL Source 102 Ext In Offset DAC and Switch 103 Path 1 & 2 and Ext Out 104 Path 1: Attenuators and Summing Amp 105 Path 2: Attenuators and Summing Amp 106 DC-Couple Mode, CW bias DAC, Course+Fine DAC 107 Drift Canceller 108 IQ Polarity Switch 109 RMS to DC Converter 110 (not used) 111 Wideband Path Test	“Self-Tests 1xx for the A13 I/Q Multiplexer” on page 39
A5 Sampler 200 Power Supply 201 Tuning + Bias Test 202 Coarse Loop Detector 203 YO Loop Detector	“Self-Tests 2xx: A5 Sampler Self-Test Errors” on page 42
A7 Reference (Std.) 300 1 GHz Detector 301 Tuning Voltage	“Self-Tests 3xx: A7 Reference (Standard) Self-Test Errors (For instruments with serial prefixes < US4805/MY4805)” on page 44
A8 Output 400 Ground and PTAT Test 401 Prelevel Loop Test 402 Quadrature DAC Test 403 VBLO Test 404 Marble Test 405 Gain Adjustment Test 406 Prelevel Bypass Test 407 Switched Filters Test 408 (not used)	“Self-Tests 4xx: A8 Output Self-Test Errors (E8267D only)” on page 45

Table 1-4 Self-test Failures and Related Troubleshooting (Continued)

If this self-test fails...	Go to this troubleshooting section...
409 ALC Modulation Test 410 Burst Modulation Test 411 (not used) 412 HET Band Test	
A9 YIG Driver 600 Post Regulator 601 DACs 602 PLL Interface 603 FM Driver 604 Sweep DACs 605 Sweep Lock	“Self-Tests 6xx: A9 YIG Driver Self-Test Errors” on page 48
A6 Frac-N 700 Ref Voltage 701 Loop Gain 702 Tuning Voltage 703 Output Voltage 704 Filter Test 705 F/2 Test 706 FM Path Test 707 Sweep Phase Detector Test	“Self-Tests 7xx: A6 Frac-N Self-Test Errors” on page 51
A45 Frac-N 720 Ref Voltage 721 1 GHz Input 722 Open Loop VCO 723 Open Loop F/2 724 Close Loop VCO 725 Low Band Filter	“Self-Tests 7xx: A45 Frac-N Self-Test Errors (option UNY)” on page 54
A10 ALC 900 Power Supply 901 Detector Test 902 Detector Level to ALC Ref 903 Level Test 904 Scalar Pulse Test 905 ALC Mod 906 Scan Mod Test	“Self-Tests 9xx: A10 ALC Self-Test Errors” on page 55
A7 Reference (Option UNR/UNX) 1000 Power Supply	“Self-Tests 10xx: A7 Reference (Option UNR/UNX and Instruments with Serial Prefixes >= US4805/MY4805) Self-Test Errors” on page 58

Table 1-4 Self-test Failures and Related Troubleshooting (Continued)

If this self-test fails...	Go to this troubleshooting section...
1001 10 MHz Test 1002 1 GHz Test	
A18 CPU 1100 Power Supply	“Self-Tests 11xx: A18 CPU Self-Test Errors” on page 60
A26 Micro Interface Deck (E8257D) 1200 Power Supply 1201 Mod Filter 1202 20 GHz Doubler 1203 40 GHz Doubler (Option 540 only) 1204 RF Path 1205 LB Pulse Mod 1208 Quadraplier (Options 550 & 567)	“Self-Tests 12xx: A26 MID Self-Test Errors (E8257D)” on page 61
A26 Micro Interface Deck (E8267D) 1200 Power Supply 1201 Mod Filter 1202 20 GHz Doubler 1203 40 GHz Doubler (Options 532 & 544) 1204 RF Path 1205 LB Pulse Mod 1206 20 GHz IQ Modulator	“Self-Tests 12xx: A26 MID Self-Test Errors (E8267D)” on page 67
1207 Upconverter (Options 532 & 544) 1208 (not used) 1209 Downconverter Test	
A11 Pulse/Analog Modulation Generator 1300 Power Supply 1301 Internal Pulse Generator Clock	“Self-Tests 13xx: A11 Analog/Pulse Modulation Generator Self-Test Errors” on page 73
1302 Output 1303 Voltage Ref DAC 1304 20 GHz Pulse 1305 44 GHz Upconverter Pulse 1306 Standard 3 GHz Pulse 1307 High Performance 3 GHz Pulse 1308 Numeric Synthesizer 1309 Function Generator Channel 1 1310 Function Generator Channel 2 1311 Frequency Modulation 1312 Low Frequency Out 1313 Amplitude Modulation 1314 External 1	

Table 1-4 Self-test Failures and Related Troubleshooting (Continued)

If this self-test fails...	Go to this troubleshooting section...
1315 External 2 1316 AM Path Loss	
A14 Baseband Generator 1600 Host <-> BBG Comm 1601 Apps 1 <-> Apps 2 Comm 1602 Apps 1 <-> SH4 Comm 1603 Apps 2 <-> SH4 Comm 1604 FLiegan <-> Apps 2 Comm 1605 SRAM Test 1606 SDRAM Test 1607 Paren <-> SH4 Comm 1608 VCO Tune Test 1609 IQ DAC Output 1610 PLL Test	“Self-Tests 16xx for the A14 Baseband Generator (Option 601/602)” on page 76
A8 Output 2200 Ground and PTAT Test 2201 Prelevel Loop Test 2202 Switched Filters Test 2203 ALC Mod System Test 2204 Pulse Mod System Test 2205 RF Path Test 2206 Het Band Test	“Self-Tests 22xx: A8 Output Self-Test Errors” on page 79
A38 Lowband Filter 2400 Power Supply Test 2401 RF Path Test 2402 Lowband Amp/Filter Power Supply 2403 RF Path	“Self-Tests 24xx: A38 Lowband Filter Self-Test Errors” on page 81
A43 Lowband Amp 2500 lowband Amp/Filter Power Supply 2501 RF Amp Test 2502 Filter Path Test 2503 Pulse Modulator Test 2504 Step Attenuator Test	“Self-Tests 25xx: A43 Amp Filter Self-Test Errors” on page 82
2505 Divider On/Off Test	
A8 Output 2600 Power Supply Tests 2601 Prelevel Loop Test 2602 ALC Modulator Test 2603 Pulse Modulator Test	“Self-Tests 26xx: A8 Output Self-Test Errors” on page 84

Table 1-4 Self-test Failures and Related Troubleshooting (Continued)

If this self-test fails...	Go to this troubleshooting section...
2604 Clamp Detector Test 2605 Bias Switch Test 2606 Switched Filters Test 2607 DAC Functionality Test 2608 Het Band Test	
A46 Offset Loop 2701 Offset VCO 2702 Fstep at OSL 2703 Offset Loop Detector 2704 Fcomb at YOL 2705 YO Loop Detector	“Self-Tests 27xx: A46 Offset Loop Self-Test Errors (Option UNY)” on page 86
A8 Output 2800 Power Supply Tests 2801 Prelevel Loop Test 2802 ALC Modulator Test 2803 Pulse Modulator Test 2804 Clamp Detector Test 2805 Bias Switch Test 2806 Switched Filters Test 2807 DAC Functionality Test	“Self-Tests 28xx: A8 Vector Output Self-Test Errors” on page 86

Troubleshooting Assembly-Level Problems

This section provides the following:

- “Front-Panel Display Assembly Troubleshooting” on page 14
- “Power Supply Troubleshooting” on page 21
- “Option 008/009 Troubleshooting” on page 38
- “Self-Tests 1xx for the A13 I/Q Multiplexer” on page 39
- “Self-Tests 2xx: A5 Sampler Self-Test Errors” on page 42
- “Self-Tests 3xx: A7 Reference (Standard) Self-Test Errors (For instruments with serial prefixes < US4805/MY4805)” on page 44
- “Self-Tests 4xx: A8 Output Self-Test Errors (E8267D only)” on page 45
- “Self-Tests 6xx: A9 YIG Driver Self-Test Errors” on page 48
- “Self-Tests 7xx: A6 Frac-N Self-Test Errors” on page 51
- “Self-Tests 9xx: A10 ALC Self-Test Errors” on page 55
- “Self-Tests 10xx: A7 Reference (Option UNR/UNX and Instruments with Serial Prefixes >= US4805/MY4805) Self-Test Errors” on page 58
- “Self-Tests 11xx: A18 CPU Self-Test Errors” on page 60
- “Self-Tests 12xx: A26 MID Self-Test Errors (E8257D)” on page 61
- “Self-Tests 12xx: A26 MID Self-Test Errors (E8267D)” on page 67
- “Self-Tests 13xx: A11 Analog/Pulse Modulation Generator Self-Test Errors” on page 73
- “Self-Tests 16xx for the A14 Baseband Generator (Option 601/602)” on page 76
- “Self-Tests 22xx: A8 Output Self-Test Errors” on page 79
- “Self-Tests 24xx: A38 Lowband Filter Self-Test Errors” on page 81
- “Self-Tests 25xx: A43 Amp Filter Self-Test Errors” on page 82
- “Self-Tests 26xx: A8 Output Self-Test Errors” on page 84

Front-Panel Display Assembly Troubleshooting

Overview

The Front-Panel Display Assembly comprises the following:

- a 640 x 320 pixels liquid crystal display (LCD)
- a power switch/flat panel interface board, which contains the power on/off switch, standby LED, and power-on LED

This board contains the circuitry to disable the power supply. The ON_OFF control line is pulled to a TTL **low** to disable the power supply.

Another function of the power switch/flat panel interface board is to route the 8 data bits from the A18 CPU to the A2 Display.

- a front panel board that contains the front-panel hardkeys, softkeys, and RPG
- a dc to ac inverter, which turns the LCD on and off via control lines received from the CPU

The inverter also converts the 5.2 Vdc to approximately a 160 Vrms, 40 kHz signal to drive the LCD.

Display Controls

Contrast

There are two contrast hardkeys below the A2 Display. The left up arrow key increases the contrast while the right down arrow key decreases the contrast.

Brightness

The A2 Display brightness can be adjusted from 50 (high brightness) to 1 (low brightness) using the RPG, arrow keys, or the numeric keypad.

Other display features located under the **Utility > Display** softkey, include a screen saver and inverse video.

Display Tests

The following two screen tests are available for the LCD:

- the Black Pixel Screen Test turns the display dark
- the White Pixel Screen Test turns the display bright

Softkey Location: **Utility > Display > More (1 of 2)**

To exit the test, press any front panel key.

Symptom: Dark display

1. Ensure that the front panel green power on LED is on. If not, refer to **“Power Supply Troubleshooting” on page 21**.
2. Press any front panel key to disable the screen saver.
3. If the display is still bad, check P12 on the A31 Motherboard for the following signals:

Signal	State
P12-1	5.2 Vdc
P12-3 LIGHT_EN	>3 Vdc

Signal	State
P12-4 VDISP	Brightness = 50, VDSP < 50 mV Brightness = 1, VDSP = 3 Vdc

- If the 5.2 Vdc line is bad, refer to **“Power Supply Troubleshooting” on page 21**.
- If either the LIGHT_EN or VDISP are bad, check them at P221-16 and P221-55 respectively on the A31 Motherboard. If **either** signal is bad at P221, replace the A18 CPU.
- If all the above signals are good, check the output of the dc to ac inverter as follows:
 - a. Remove the front panel from the frame, and lay the front panel face down.
 - b. With CN2-1 open, there is typically a 160 Vrms 40 kHz signal. If not, replace the dc to ac inverter.
 If the signal is there, replace the LCD.

Symptom: Bright display without characters

1. Ensure that the front-panel green power on LED is on. If not, refer to **“Power Supply Troubleshooting” on page 21**.
2. Try adjusting the contrast controls.
3. Check the connection of the ribbon cable at J9 of the power switch/flat panel interface board.
4. If the display is still too bright, use an oscilloscope to check P11 of the A31 Motherboard for the following signals:

Signal	State
P11-4 VLCD	approximately 19.5 to 21 Vdc ^a
P11-6 LCD_ENABLE_H	>3 Vdc
P11-9, 10, 12, 13, 15, 16, 18, 19, 21, 22, 24, 25, 27, 28, 30, 31, 33, 34, 36, 37, 39, 40	Refer to Figure 1-1 .

- a. If >21V check the power supplies. If the power supplies are good, replace the motherboard.

The pulse state signals are control lines, clock, and data for the LCD.

Figure 1-1 Pulsing Activity
LCD_CLK P11-9, P221-50

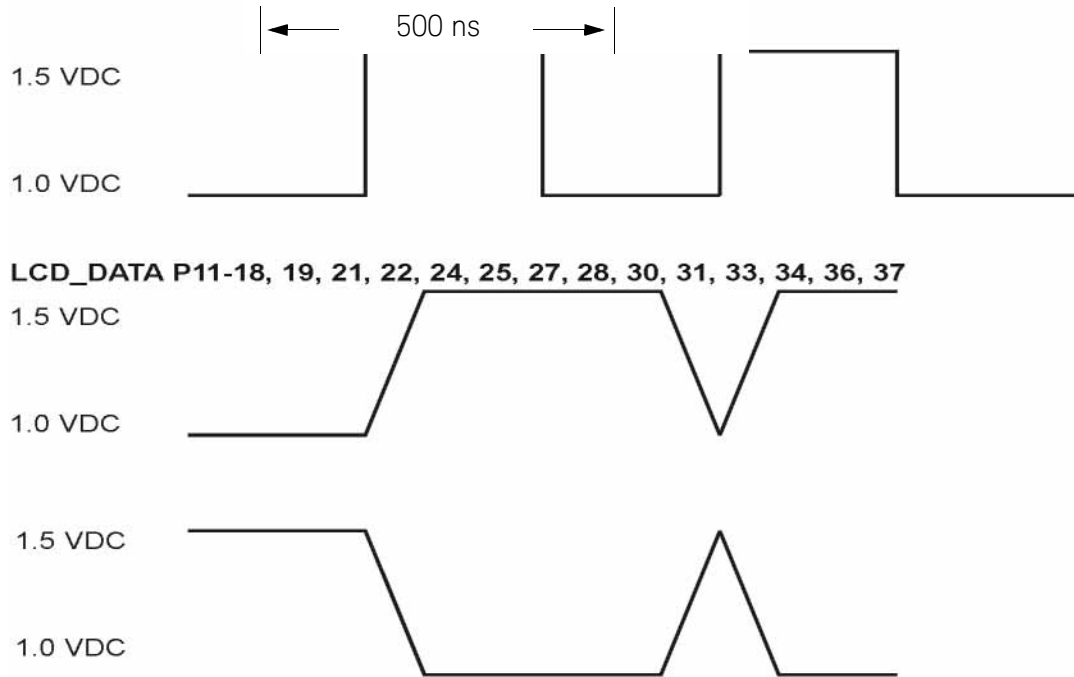

Se991a

5. If **all** the signals measured in Step 4 are good, go to Step 6.

If any of the signals measured in Step 4 are bad, check the following signals at P221 of the motherboard:

Signal	State
P221-14 VLCD	approximately 21 Vdc
P221-53 LCD_ENABLE_H	>3 Vdc
P221-1 to 13, 15, 41, 43, 45, 47, 49 to 52	Refer to Figure 1-1 on page 17 .

If any of these signals are bad, change the CPU board.

6. If all the signals measured in Step 4 are good, check the following signals at J9 of the power switch. To access J9 the front panel must be removed from the chassis frame and laid face down.

Signal	State
J9-7 VLCD	approximately 21 Vdc

Signal	State
J9-4 LCD_ENABLE_H	>3 Vdc
J9-5	5.2 Vdc
J9-1, 2, 3, 8 to 15	Refer Figure 1-1 on page 17 .

If these signals are good, replace the LCD.

If these signals are not good, replace the power switch/flat panel interface board.

Symptom: Hardkeys or softkeys do not work

The A1 Keyboard contains the hardkeys and softkeys switches. The keys are arranged in a matrix (shown below) with the control lines KEYCOLx and KEYROWx on the x and y axis. When you press a hardkey or softkey, one cell of the matrix is activated; the normally TTL low KEYROWx of the active cell pulses high, and the normally TTL high KEYCOLx of the active cell pulses low.

	KEYCOL0	KEYCOL1	KEYCOL2	KEYCOL3	KEYCOL4	KEYCOL5	KEYCOL6	KEYCOL7
KEYROW0	softkey 3	N/A	Cont Up	N/A	LF Out	N/A	I/Q	Pulse
KEYROW1	softkey 2	Incr/Set	Cont Down	Ampl	Ampl Menu	Mode Setup	Aux Fctn	FM/φM
KEYROW2	softkey 1	Up	N/A	Freq	Sweep List	Mode	Mux	AM
KEYROW3	softkey 4	N/A	N/A	Right Arrow	Help	Save	Recall	Trigger
KEYROW4	softkey 6	N/A	Local	Hold	Mod On/Off	4	5	6
KEYROW5	softkey 5	N/A	Return	Down Arrow	N/A	7	8	9
KEYROW6	N/A	N/A	N/A	Left Arrow	RF On/Off	0	.	+/-
KEYROW7	softkey 7	N/A	Preset	N/A	N/A	1	2	3

1. Ensure that the front panel green power on LED is on. If it is not on, refer to [“Power Supply Troubleshooting” on page 21](#).
2. To ensure the signal generator is not being controlled remotely, press the **Local** hardkey.
3. Use an oscilloscope to monitor the KEYCOLx and KEYROWx pins of the key that is not working at P13 on the motherboard. Use the following table to identify the appropriate pin number:

KEYCOL pins should be a TTL high	
KEYCOL0	P13-1
KEYCOL1	P13-3
KEYCOL2	P13-5
KEYCOL3	P13-7
KEYCOL4	P13-9
KEYCOL5	P13-11
KEYCOL6	P13-13
KEYCOL7	P13-15

KEYROW pins should be a TTL low	
KEYROW0	P13-17
KEYROW1	P13-19
KEYROW2	P13-21
KEYROW3	P13-23
KEYROW4	P13-25
KEYROW5	P13-26
KEYROW6	P13-24
KEYROW7	P13-22

4. If **either** signal is incorrect, use the following table and check the signal at P221, as it leaves the CPU board. If the signal is bad at P221, replace the A18 CPU.

KEYCOL pins should be a TTL high	
KEYCOL0	P13-1
KEYCOL1	P13-3
KEYCOL2	P13-5
KEYCOL3	P13-7
KEYCOL4	P13-9
KEYCOL5	P13-11
KEYCOL6	P13-13
KEYCOL7	P13-15

KEYROW pins should be a TTL low	
KEYROW0	P13-17
KEYROW1	P13-19
KEYROW2	P13-21
KEYROW3	P13-23
KEYROW4	P13-25
KEYROW5	P13-26
KEYROW6	P13-24
KEYROW7	P13-22

5. If both signals are correct, press the faulty hardkey or softkey while monitoring the KEYCOL or KEYROW on the oscilloscope. The KEYCOL line should pulse low; the KEYROW line should pulse high.

If **either** line does not function properly, replace the front panel board.

Symptom: RPG not working properly

1. Ensure that the front panel green power on LED is on. If it is not on, refer to **“Power Supply Troubleshooting” on page 21**.
2. Check the front panel operation by checking random hardkey operation.
3. Check P13-12 for +5.2 Vdc. If the voltage is not present, refer to **“Power Supply Troubleshooting” on page 21** for troubleshooting.
4. Press the Frequency hardkey on the front panel.
5. Using an oscilloscope, monitor P13-14 and P13-10 while rotating the RPG knob. The LCD frequency value should change, and both signals at P13 should pulse to a TTL high. If **either** signal does not pulse, replace the A1 Keyboard.
6. If the signals pulse at P13, check the signal at P221 pins 57 and 17 of the motherboard. If the signals pulse at P221, replace the CPU board.

Symptom: Screen saver not working properly

The screen saver delay can be set for any integer from 1 to 12 hours. The CPU board controls the screen saver by pulling the LIGHT_EN line low.

1. If the delay time elapses and the display does not go dark, check the LIGHT_EN signal at P12-3.
 - If the signal is a TTL low, replace the dc to ac inverter.
2. If the signal is a TTL high, check it at P221-16 of the motherboard.
 - If the signal is high at P221, replace the CPU board.

Power Supply Troubleshooting

The power supply is a switching supply with automatic line-voltage and frequency selection. Because of this, a switch is not required to set 115 VAC or 240 VAC operation. The input power line is fused, but the fuse is not replaceable; if the fuse opens, you must replace the power supply.

NOTE For the E8267D, if the red PS-FAULT LED is off (see [Figure 1-5](#)), troubleshoot the power supply.

WARNING After unplugging the instrument, wait 30 seconds to allow the supplies to discharge before removing or installing an assembly.

Tables 1-5 through 1-7 list the motherboard test points (connector and pin number) and power supply voltages for the E8257D. See [Figure 1-2 on page 30](#) for connector locations.

Tables 1-8 through 1-12 list the motherboard test points (connector and pin number) and power supply voltages for the E8267D, beginning on [page 1-25](#). See [Figure 1-3 on page 31](#) for connector locations.

Table 1-5 E8257D/E8663D Power Supply vs. Assembly Matrix (1 of 3)

Motherboard test points:	+32 Vdc	+15 Vdc	+10 Vdc	+8 Vdc	+9 Vdc	+5.2 Vdc
A1 Keyboard						P13-12
A2 Display						P11-44
A3 Power Supply	P231-1, 41	P231-3, 4, 43, 44	P231-6, 7, 46, 47			P231-15, 16, 18, 19, 55, 56, 58, 59
A5 Sampler	P22-7	P22-6, 21			P22-20, 5	P22-14, 29
A6 Frac-N	P32-7	P32-6, 21			P32-20, 5	P32-14, 29
A7 Reference	P42-7	P42-6, 21			P42-20, 5	P42-14, 29
A8 Output	P52-7	P52-6, 21			P52-20, 5	P52-14, 29
A9 YIG Driver	P112-6	P112-5, 30	P112-15, 16, 40		P112-17, 18, 42	P112-3, 28
A10 ALC	P122-4	P122-28				P122-2, 27
A11 Mod Gen	P132-4	P132-28				P132-2, 27
A12 Pulse Modulator	J14-10	J14-9				
A18 CPU	P223-4	P223-23	P223-39	P223-40	P223-18	P223-2, 22
A21 Rear Panel		P241-13, 14	P241-17, 18			P241-11, 12

Table 1-5 E8257D/E8663D Power Supply vs. Assembly Matrix (1 of 3)

Motherboard test points:	+32 Vdc	+15 Vdc	+10 Vdc	+8 Vdc	+9 Vdc	+5.2 Vdc
A26 Microwave Interface	P201-1	P201-2, 3, 4	P201-5, 6, 7, 8, 9, 10	P201-29		P201-13, 14, 15, 16, 17, 18
A23 Lowband Coupler/Detector		J15-8				
A27 40 GHz Doubler (E8257D only)		J33-5	J33-19	J33-21		J33-7, 9
A29 20 GHz Doubler		J32-5	J32-19	J32-21		J32-7, 9
A30 Mod Filter		J31-5	J31-19	J31-21		J31-7, 9
A36 Quadraplier (E8257D only)		J34-2				J34-5, 6, 7
AT1 Attenuator		J13-1				
A38 Low Band Switch Filter	P142-4	P142-20				P142-2, 27

Table 1-6 E8257D/E8663D Power Supply vs. Assembly Matrix (2 of 3)

Motherboard test points:	+5.2 Digital	+3.4 Digital	+2.6 Vdc	-7 Vdc	-6 Vdc	+1.8 Vdc
A2 Display	P11-44					
A2DS1 Backlight	P12-1					
A3 Power Supply	P231-21, 22, 25, 61, 62, 65,	P231-28, 29, 32, 35, 36, 68, 69, 72, 75, 76		P231-9, 10, 49, 50		
A5 Sampler					P22-3, 18	
A6 Frac-N					P32-3, 18	
A7 Reference					P42-3, 18	
A8 Output					P52-3, 18	
A9 YIG Driver	P111-64, 65, 129, 130	P111-60, 61, 62, 63, 125, 126, 127, 128	P11-57, 58, 59, 123, 124	P112-11, 12, 13, 14, 38	P112-19, 44	
A10 ALC	P121-64, 65, 129, 130	P121-60, 61, 62, 63, 125, 126, 127, 128	P121-57, 58, 59, 123, 124			
A11 Mod Gen	P131-64, 65, 129, 130	P131-60, 61, 62, 63, 125, 126, 127, 128	P131-57, 58, 59, 123, 124			
A18 CPU	P222-49, 50, 99, 100	P222-45, 46, 47, 48, 95, 96, 97, 98		P223-37	P223-17	
A26 Microwave Interface	P201-23	P201-24		P201-30, 33, 46		
A36 Quadraplier (E8257D only)	J34-24					

Table 1-6 E8257D/E8663D Power Supply vs. Assembly Matrix (2 of 3) (Continued)

Motherboard test points:	+5.2 Digital	+3.4 Digital	+2.6 Vdc	-7 Vdc	-6 Vdc	+1.8 Vdc
A38 Low Band Switch Filter	P141-64, 65, 129, 130	P141-60, 61, 62, 63, 125, 126, 127, 128	P141-57, 58, 59, 123, 124			P141-57, 55, 56, 117, 120, 121
AT1 Attenuator		J13-2				

Table 1-7 E8257D/E8663D Power Supply vs. Assembly Matrix (3 of 3)

Motherboard test points:	-15 Vdc	-5.2 Vdc	-3 Vdc	+3.5 Vdc	+6.5 Vdc	+12 Vdc	+15 Vdc stby	Fan Voltage
A2 Display							P11-43	
A3 Power Supply	P231-12, 13, 52, 53						P231-80	
A5 Sampler	P22-2, 17	P22-4, 19						
A6 Frac-N	P32-2, 17	P32-4, 19						
A7 Reference	P42-2, 17	P42-4, 19						
A8 Output	P52-2, 17	P52-4, 19						
A9 YIG Driver	P112-4, 29	P112-1, 2, 26, 27						
A10 ALC	P122-3	P122-1, 26						
A11 Mod Gen	P132-3	P132-1, 26						
A12 Pulse Modulator	J14-7	P201-31, 32						
A18 CPU	P223-3	P223-1					P223-21	
A21 Rear Panel	P241-15, 16	P241-9, 10					P241-5, 6, 7, 8	
A23 Lowband Coupler/Detector	J15-10							
A26 Microwave Interface	P201-11, 12	P201-31, 32						
A27 40 GHz Doubler (E8257D only)	J33-4	J33-8						
A29 20 GHz Doubler	J32-4	J32-8				J32-1, 3		

Table 1-7 E8257D/E8663D Power Supply vs. Assembly Matrix (3 of 3) (Continued)

Motherboard test points:	-15 Vdc	-5.2 Vdc	-3 Vdc	+3.5 Vdc	+6.5 Vdc	+12 Vdc	+15 Vdc stby	Fan Voltage
A30 Mod Filter	J31-4	J31-8				J31-1, 3		
A36 Quadraplier (E8257D only)	J34-3		J34-17	J34-11, 12, 13, 14, 15	J34-8, 9			
A38 Low Band Switch Filter	P142-3	P142-26						
B1 Fan								Fan+ P252-2 P252-2 Fan- P252-1 P252-1

Table 1-8 E8267D Power Supply vs. Assembly Matrix (1 of 5)

Motherboard Test Points:	LED +32 VDC	-24 VREF	LED +15 VDC	+15 VAF	LED +10 VDC	LED +8 VDC
A3 Power Supply	J231-A4-6		J231-B1-3, D1-3 J232-A4-6		J233-B1-3, D1-3	
A6 Frac N	P32-7		P32-6, 21			
A7 Reference	P42-7		P42-6, 21			
A8 Lowband Output	P52-7		P52-6, 21			
A9 YIG Driver	P112-6		P112-5, 30		P112-15, 16, 40	
A10 ALC	P122-4		P122-28			
A11 Mod Gen	P132-4		P132-28			
A13 I/Q Multiplexer	P152-4		P152-28			
A14 Baseband Generator	P162-4		P162-28			
A18 CPU	P223-4		P223-23		P223-39	P223-40
A21 Rear Panel			P241-13, 14		P241-17, 18	
A23 Lowband Coupler/Det			J15-8			
A26 Microwave Interface	P201-1 1		P201-2, 3, 4		P201-5, 6, 7, 8, 9, 10	P201-29 ^a
A27 40 GHz Doubler			J36-5		J36-19	J36-21
A29 20 GHz Doubler			J32-5		J32-19	J32-21
A30 20 GHz Mod Filter			J31-5		J31-19	J31-21
A35 20 GHz I/Q Modulator		J34-8 ^a		J34-3 ^a		
A37 45 GHz Upconverter				J35-10		
A38 Low Band Switch Filter	P142-4		P142-20			
AT1 Attenuator			J13-1			

a. Originates on microwave interface.

Table 1-9 E8267D Power Supply vs. Assembly Matrix (2 of 5)

Motherboard Test Points:	+8 VA	LED +9 VDC	LED +5.2 VDC	+5.2 VAF	LED +5.2D	+5.2 VDF
A1 Keyboard			P1-12			
A2 Display			P11-44			
A2DS1 Backlight					P12-1	

Table 1-9 E8267D Power Supply vs. Assembly Matrix (2 of 5)

Motherboard Test Points:	+8 VA	LED +9 VDC	LED +5.2 VDC	+5.2 VAF	LED +5.2D	+5.2 VDF
A3 Power Supply			J232-B1-3, C4-6, D1-3		J236-B1-3, D1-3	
A5 Sampler		P22-20, 5	P22-14, 29			
A6 Frac N		P32-20, 5	P32-14, 29			
A7 Reference		P42-20, 5	P42-14, 29			
A8 Lowband Output		P52-20, 5	P52-14, 29			
A9 YIG Driver		P112-17, 18, 42 ^a	P112-3, 28		P111-64, 65, 129, 130	
A10 ALC			P122-2, 27		P122-64, 65, 129, 130	
A11 Mod Gen			P132-2, 27		P132-64, 65, 129, 130	
A13 I/Q Multiplexer			P152-2, 27		P151-64, 65, 129, 130	
A14 Baseband Generator			P162-2, 27		P161-64, 65, 129, 130	
A18 CPU		P223-18	P223-2, 22		P222-49, 50, 99, 100	
A21 Rear Panel			P241-11, 12			
A23 Lowband Coupler/Det			J15-12			
A26 Microwave Interface			P201-13, 14, 15, 16, 17, 18		P201-23	
A27 40 GHz Doubler			J36-7, 9			
A29 20 GHz Doubler			J32-7, 9			
A30 20 GHz Mod Filter			J31-7, 9			
A35 20 GHz I/Q Modulator	J34-5, 6 ^b			J34-7 ^b		J34-28 ^b
A37 45 GHz Upconverter	J35-7, 8			J35-1, 2, 3, 11		J35-16
A38 Low Band Switch Filter			P142-2, 27		P141-64, 65, 129, 130	
AT1 Attenuator					J13-2	

- a. Originates on YTO Driver
 b. Originates on microwave interface

Table 1-10 E8267D Power Supply vs. Assembly Matrix (3 of 5)

Motherboard Test Points:	LED +3.4D	LED +2.6VD	LED -7 VDC	LED -6 VDC	LED -15 VDC	-15 VAF
A2DS1 Backlight					P12-1	
A3 Power Supply	J236-A4-6, C4-6, E4-6 J237-A4-6, B1-3, C4-6, D1-3	J238-A4-6, B1-3, E4-6 J239-A4-6, B1-3	J233-A4-6, C4-6, E4-6		J231-C4-6, E4-6	
A5 Sampler				P22-3, 18	P22-2	
A6 Frac N				P32-3, 18	P32-2	
A7 Reference				P42-3, 18	P42-2	
A8 Lowband Output				P52-3, 18	P52-2	
A9 YIG Driver	P111-60, 61, 62, 63, 125, 126, 127, 128	P112-57, 58, 59, 123, 124	P112-11, 12, 13, 14, 38	P112-19, 44 ^a	P112-4, 29	
A10 ALC	P122-60, 61, 62, 63, 125, 126, 127, 128	P122-57, 58, 59, 123, 124			P122-3	
A11 Mod Gen	P132-60, 61, 62, 63, 125, 126, 127, 128	P132-57, 58, 5, 123, 124			P132-3	
A13 I/Q Multiplexer	P151-60, 61, 62, 63, 125, 126, 127, 128	P151-57, 58, 59, 123, 124			P152-3	
A14 Baseband Generator	P161-60, 61, 62, 63, 125, 126, 127, 128	P161-57, 58, 59, 123, 124			P162-3	
A18CPU	P222-45, 46, 47, 48, 95, 96, 97, 98		P223-37	P223-17	P223-3	
A21 Rear Panel					P241-15, 16	
A23 Lowband Coupler/Det					J15-10	
A26 Microwave Interface	P201-24		P201-30, 33, 46		P201-11, 12	
A27 40 GHz Doubler					J36-4	
A29 20 GHz Doubler					J32-4	
A30 20 GHz Mod Filter					J31-4	
A35 20 GHz I/Q Modulator						J34-4 ^b

Table 1-10 E8267D Power Supply vs. Assembly Matrix (3 of 5)

Motherboard Test Points:	LED +3.4D	LED +2.6VD	LED -7 VDC	LED -6 VDC	LED -15 VDC	-15 VAF
A37 45 GHz Upconverter						J35-11
A38 Low Band Switch Filter	P141-60, 61, 62, 63, 125, 126, 127, 128	P141-57, 58, 59, 123, 124			P142-3	

- a. Originates on YTO driver
- b. Originates on Microwave Interface

Table 1-11 E8267D Power Supply vs. Assembly Matrix (4 of 5)

Motherboard Test Points:	LED -5.2V	LED -5.2 V2 ^a	+1.8 VDC	+12 VDC	LED +15 VSTBY	Fan Voltage
A2 Display					P11-43	
A3 Power Supply					J235-E4, 5	
A5 Sampler	P22-4, 19					
A6 Frac N	P32-4, 19					
A7 Reference	P42-4, 19					
A8 Lowband Output	P52-4, 19					
A9 YIG Driver	P112-1, 2, 26, 27 ^b					
A10 ALC	P122-1, 26					
A11 Mod Gen	P132-1, 26					
A13 I/Q Multiplexer	P152-1	P152-26				
A14 Baseband Generator	P162-1	P162-26				
A18 CPU		P223-1			P223-21	
A21 Rear Panel		P241-9, 10			P241-5, 6, 7, 8	
A26 Microwave Interface	P201-31, 32					
A27 40 GHz Doubler	J36-8					
A29 20 GHz Doubler	J32-8			J32-1, 3 ^c		
A30 20 GHz Mod Filter	J31-8			J31-1, 3 ^c		
A35 20 GHz I/Q Modulator				J34-9 ^c		
A38 LB Switch Filter	P142-26		P141-51, 55, 56, 117, 120, 121			

Table 1-11 E8267D Power Supply vs. Assembly Matrix (4 of 5)

Motherboard Test Points:	LED -5.2V	LED -5.2 V2^a	+1.8 VDC	+12 VDC	LED +15 VSTBY	Fan Voltage
B1 Fan						Fan+ P252-2, P251-2 Fan- P252-1, P251-1

- a. Voltage regulator on motherboard
- b. Originates on YTO Driver
- c. Originates on Microwave Interface

Table 1-12 E8267D Power Supply vs. Assembly Matrix (5 of 5)

Motherboard Test Points:	LED +1.95VD1^a	LED +1.8VD_1^a
Baseband Generator	P161-52, 118	P161-55, 56, 120-122

- a. Voltage regulator on motherboard

Figure 1-2 E8257D (Analog) Motherboard Connectors – Bottom View

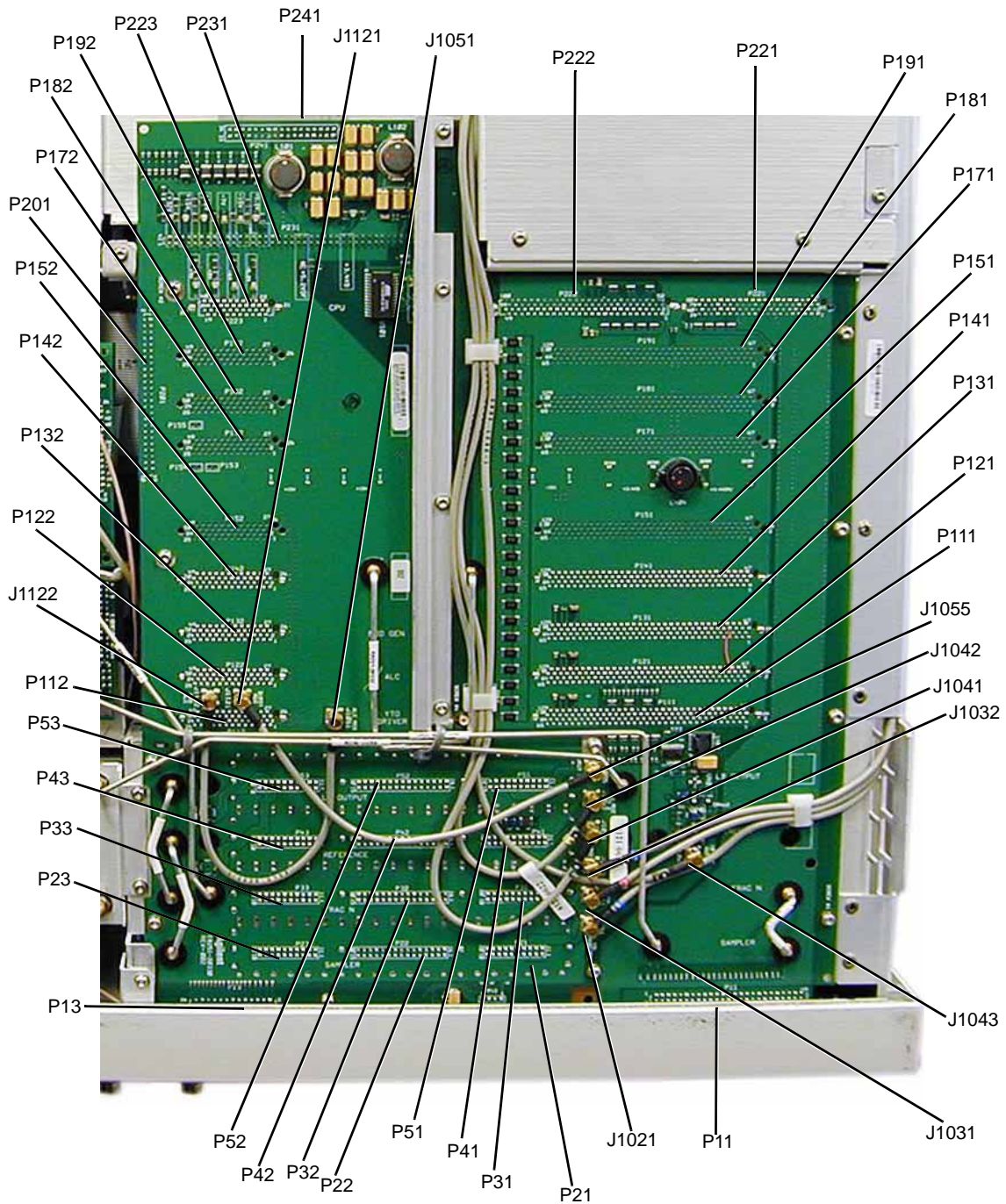
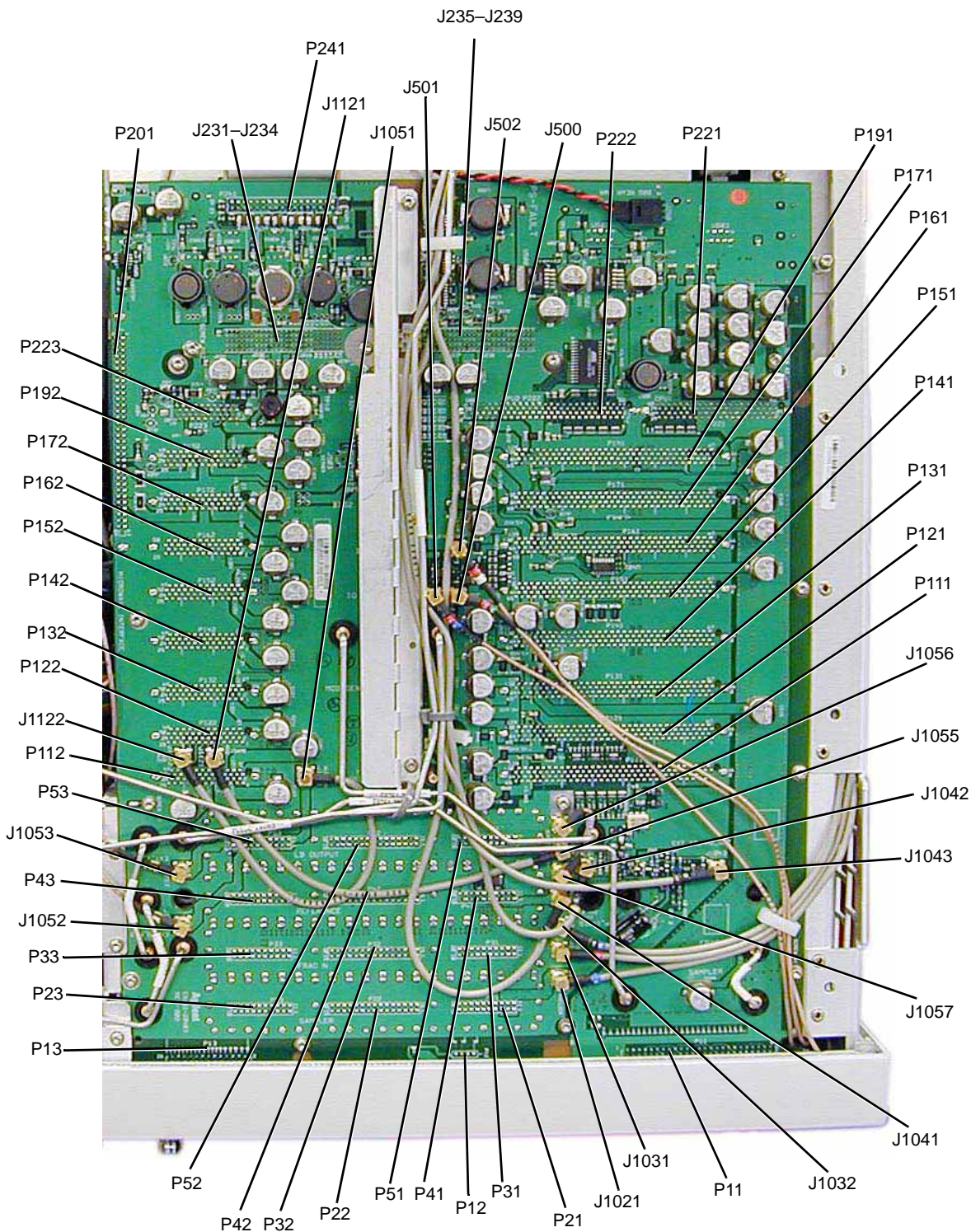

Figure 1-3 E8267D (Vector) Motherboard Connectors - Bottom View



Symptom: amber standby LED not working properly

With the instrument plugged in and the power turned off, the front panel amber standby LED should be on, as well as the green +15 Standby LED on the motherboard. This is controlled by the +15 Standby line supplied by the power supply, which is routed via the motherboard to the front panel.

To troubleshoot, turn the instrument off and follow the signal path.

Symptom: front panel green LED not working properly

When the front panel power switch is turned on, the amber LED should go out and the green LED should come on. Also, the fan should start rotating and the front panel display should illuminate.

Troubleshooting:

- Verify the supply voltages at P11 of the A31 Motherboard.
- If the supply voltages are correct, replace the Power Switch/Flat Panel Interface Board.

Symptom: fan not working

The fan is connected to the motherboard, and is audible when the instrument is on. The fan voltage is +14V.

To troubleshoot, verify that all supplies are working; disconnect the fan from the rear panel assembly at P6 and check the fan voltage at P6-2. If the fan voltage is correct, replace the fan.

Symptom: Instrument does not power up; power supply LEDs not on

Checking Power Supplies

Each of the power supplies has an LED on the bottom of the motherboard (see [Figure 1-4 on page 34](#) and [Figure 1-5 on page 35](#)). When the power supply is functioning, the green LED lights. Use a DVM to measure the supplies on the motherboard, and ensure they meet the following power supply specifications.

Supply Voltage	Acceptable Voltage (Vdc)	Maximum Ripple (mVpp)	Supply Voltage	Acceptable Voltage (Vdc)	Maximum Ripple (mVpp)
+32	32 ± 1.0	10	+5.2VDF	5.2 ± 0.15	10
+15	15 ± 0.5	10	+3.4 VD	3.4 ± 1.0	10
+15 Standby	15 ± 0.75	20	-5.2	-5.2 ± 0.1	10
+10	10.2 ± 0.2	10	-6	-6 ± 0.12	10
+9	9 ± 0.18	10	-7	-7 ± 0.1	10
+8	8 ± 0.5	10	-15	-15 ± 0.5	10

Supply Voltage	Acceptable Voltage (Vdc)	Maximum Ripple (mVpp)	Supply Voltage	Acceptable Voltage (Vdc)	Maximum Ripple (mVpp)
+5.2	5.2 ± 0.15	10			

Supply Voltage	Acceptable Voltage (Vdc)	Maximum Ripple (mVpp)
+32	32 ± 0.96	10
+15	15 ± 0.45	10
+15 Standby	15 ± 0.45	20
+10	10 ± 0.3	10
+9	9 ± 0.18	10
+8	8 ± 0.5	10
+5.2	5.2 ± 0.16	10
+5.2 D	5.2 ± 0.16	20
+3.4	3.4 ± 0.1	10
+2.6 D	2.6 ± 0.08	10

Supply Voltage	Acceptable Voltage (Vdc)	Maximum Ripple (mVpp)
+1.95 VD_1	1.95 ± 0.06	10
+1.95 VD_2	1.95 ± 0.06	10
+1.8 VD_1	1.8 ± 0.05	10
+1.8 VD_2	1.8 ± 0.05	10
-5.2	-5.2 ± 0.1	10
-5.2 V2	-5.2 ± 0.16	10
-6.0	-6 ± 0.12	10
-7.0	-7.0 ± 0.21	10
-15	-15 ± 0.45	10

If a supply LED is not lit, or a measured voltage is less than the acceptable value, an assembly may be loading down that supply. Using the appropriate [Power Supply vs. Assembly Matrix](#), determine where each supply is used, then use the following steps to isolate the defective assembly.

CAUTION

Remove a **minimum** number of assemblies at one time. If the power supply does not have a minimum load on it, the supply voltage increases to an overvoltage condition.

1. Turn off the instrument and remove one of the assemblies biased by the faulty supply.
2. Turn the instrument on and check the faulty supply. If the supply LED lights, replace the assembly removed in Step 1. If not, continue with Step 3.
3. Turn the instrument off and reinstall the assembly removed in Step 1. Remove the next assembly and see if the supply LED lights. Continue this process until the supply functions properly.

4. Replace the last assembly that you removed.

Figure 1-4

E8257D Motherboard Power Supply LEDs

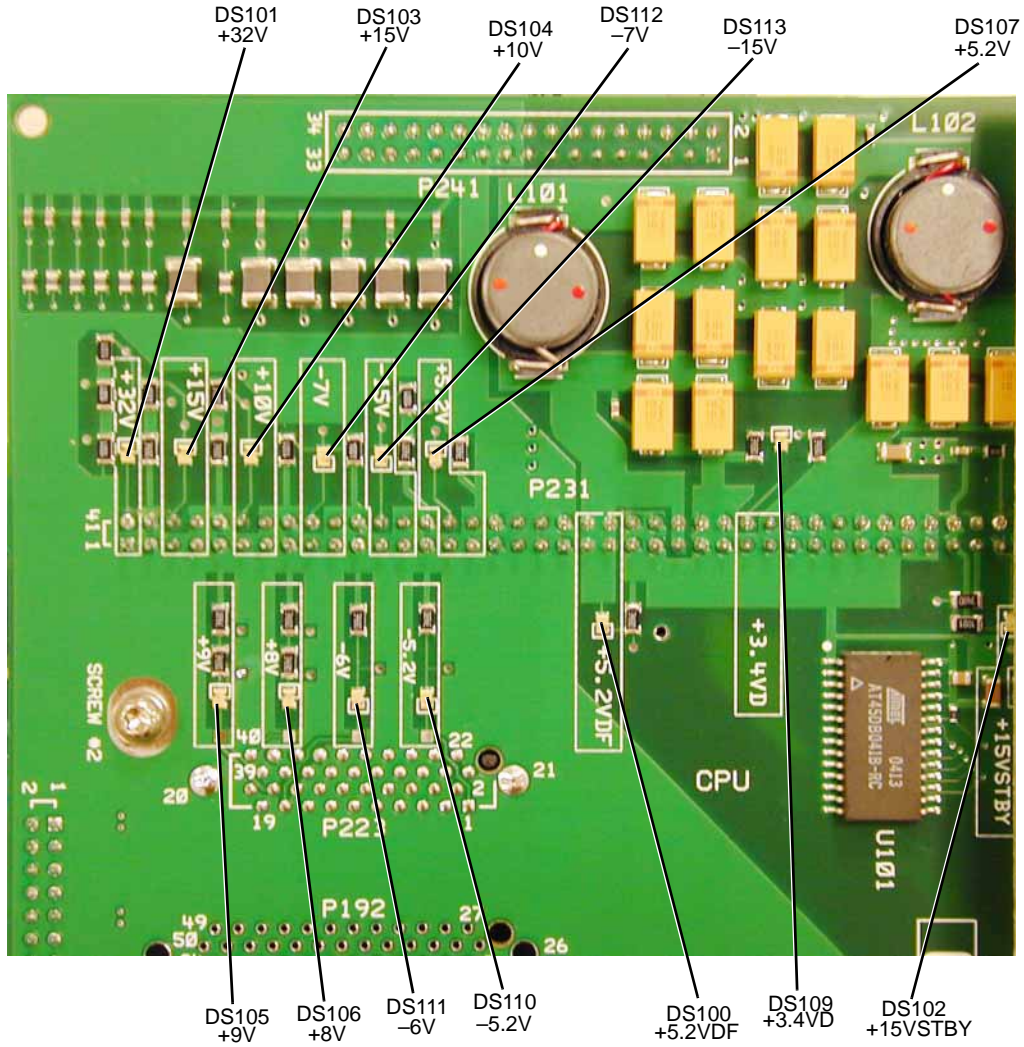
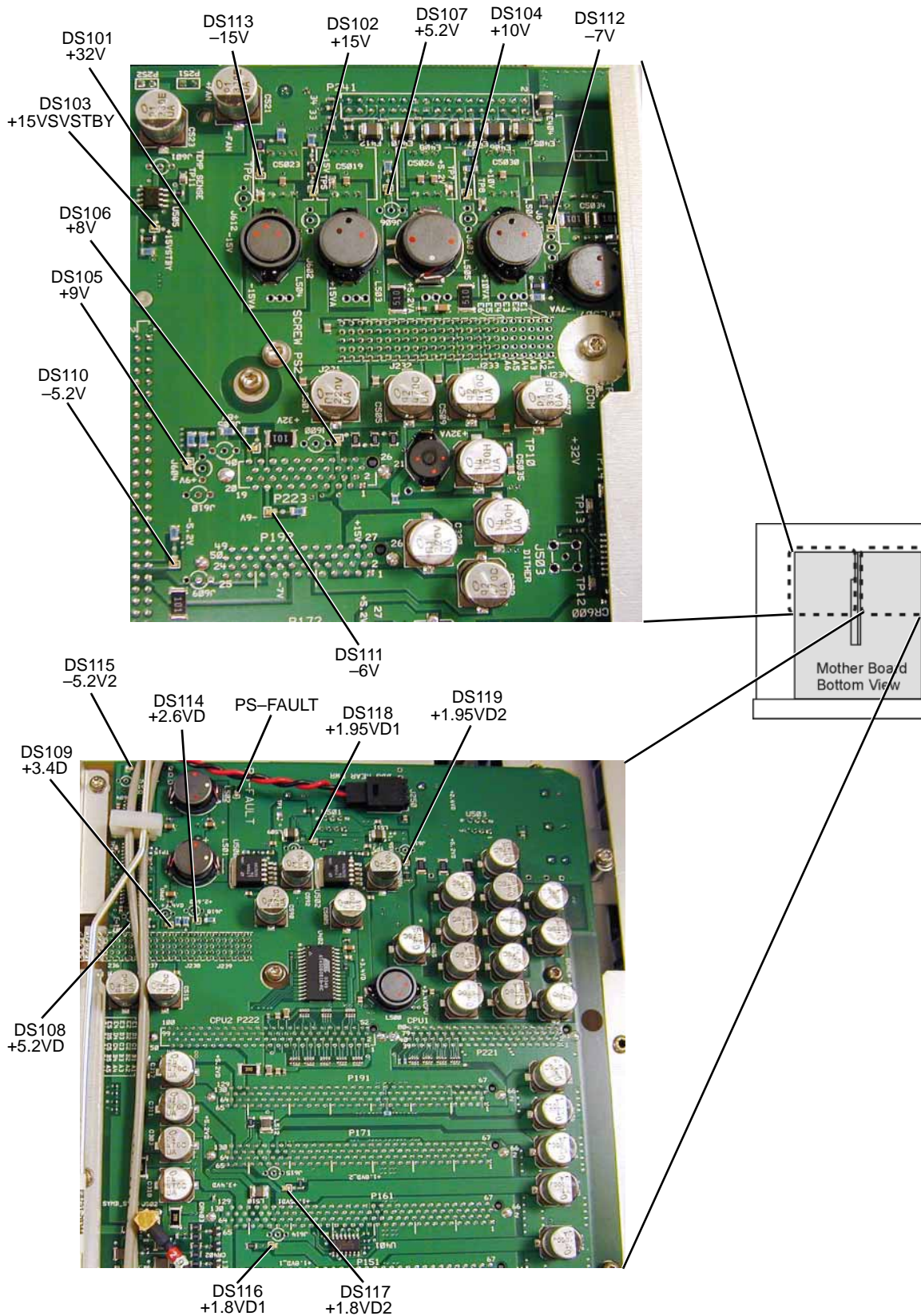

Figure 1-5 E8267D Motherboard Power Supply LEDs



Power Switch On/Off Line

If the control line (ON/OFF) from the A3 Power Switch located in the front panel assembly goes to a TTL low state, or if the line impedance is less than 500 ohms, the power supply shuts down. This signal can be measured on the A31 Motherboard at pin 79 of P241.

To troubleshoot:

1. Turn the front panel switch on and ensure that the +15 Standby is good.
2. Verify that the ON/OFF control line is > 3.5 Vdc.

The Power Switch/Flat-Panel Interface Board in the front panel assembly controls this signal.

Symptom: Green front panel LED and power supply LEDs on motherboard blinking

Overvoltage or Overcurrent

The individual supplies in the instrument are not fused, but an overvoltage or overcurrent condition can shut them down. With either of these conditions, the front panel green LED and the power supply LEDs blink at approximately 2 Hz. The power supply tries to revive, but if the condition does not clear, the instrument stays in this mode. In some cases, cycling power fixes the problem.

To troubleshoot, use the following steps to isolate the defective assembly:

CAUTION

Remove a **minimum** number of assemblies at one time. If the power supply does not have a minimum load on it, the supply voltage increases to an overvoltage condition.

NOTE

Refer to the Power Supply vs. Assembly matrix tables, starting on [page 22](#), for help in determining which assembly uses which power supplies.

1. Turn off the instrument and remove one of the assemblies biased by the faulty supply.
2. Turn the instrument on and check whether the overvoltage or overcurrent condition still exists. If it does not, replace the assembly removed in Step 1. If it does, continue with Step 3.
3. Turn the instrument off and reinstall the assembly removed in Step 1. Remove the next assembly and see if that fixes the problem. Continue this process until the supply functions properly.
4. Replace the last assembly that you removed.

Symptom: Amber front panel LED blinking

Thermal shutdown

With thermal shutdown, the front panel green LED and the power supply LEDs blink as long as the condition exists. There are two temperature sensing devices in the instrument: one on the A8 Output, and one on the A19 Power Supply.

To troubleshoot:

1. If the instrument is hot, ensure that the fan is working and let the instrument cool off.
2. If the instrument still shuts down, remove the Output assembly.
3. If the instrument still shuts down, replace the Power Supply.

or

If the instrument powers on, but the amber LED continues to blink, replace the A3 Power Switch assembly.

Symptom; +9, -6, or -5.2 V LEDs not on

These supplies are generated on the YIG Driver Assembly.

Troubleshoot using the [Power Supply vs. Assembly Matrix](#) that begins on [page 1-21](#).

1. At P112 of the Motherboard, ensure the YIG Driver Assembly is receiving the +32, +15, +10, -7, -15 Vdc supplies.
2. If the supplies are present at P112, note in the matrix where each supply is used.
3. Power down the instrument and remove one of the assemblies that is biased by the faulty supply.
4. Power the instrument up again and check the faulty supply. If it is still bad, power down and re-install the first assembly removed.
5. Remove the next assembly and see if that fixes the problem. Continue this process until the supply functions properly.
6. Replace the last assembly that you removed.

Symptom: +1.95 VD, +1.8 VD LEDs not on

These supplies are generated by voltage regulators on the A31 Motherboard.

Troubleshoot by checking the following voltages at the A19 Power Supply:

- +3.4 VD, which is regulated down to +1.95 VD
- +2.6 VD, which is regulated down to +1.8 VD

If the supplies are good at the A19 Power Supply, replace the A31 Motherboard.

Option 008/009 Troubleshooting

Removable flash memory operation requires a license key, a compact flash drive, and a flash memory card. The flash drive communicates directly to the A18 CPU through a ribbon cable.

NOTE A flash memory card must be installed for the firmware to report Option 008/009 in the instrument.

1. Verify the flash memory card is installed.
2. Power the instrument on.
3. Check to see if Option 008 or 009 is installed in the instrument, press **Utility > Instrument Info > Diagnostic**.
4. Verify the green LED to the right of the A41 Compact Flash Door, on the instrument rear panel, turns on and off during the instrument boot-up.
5. If the green LED light does not turn on and off or Option 008/009 is not listed as an installed option,
 - a. Replace the flash memory card.
 - b. Repeat steps 2 thru 4.
6. If the green LED light still does not turn on and off or Option 008/009 is still not listed as an installed option,
 - a. Replace the A40 Compact Flash Drive.
 - b. Repeat steps 2 thru 4.
7. If the green LED light still does not turn on and off or Option 008/009 is still not listed as an installed option,
 - a. Replace the A18 CPU
 - b. Run the required performance test for the A18 CPU, see [Chapter 4, "Post-Repair Procedures."](#)
 - c. Repeat steps 2 thru 4.

Self-Tests 1xx for the A13 I/Q Multiplexer

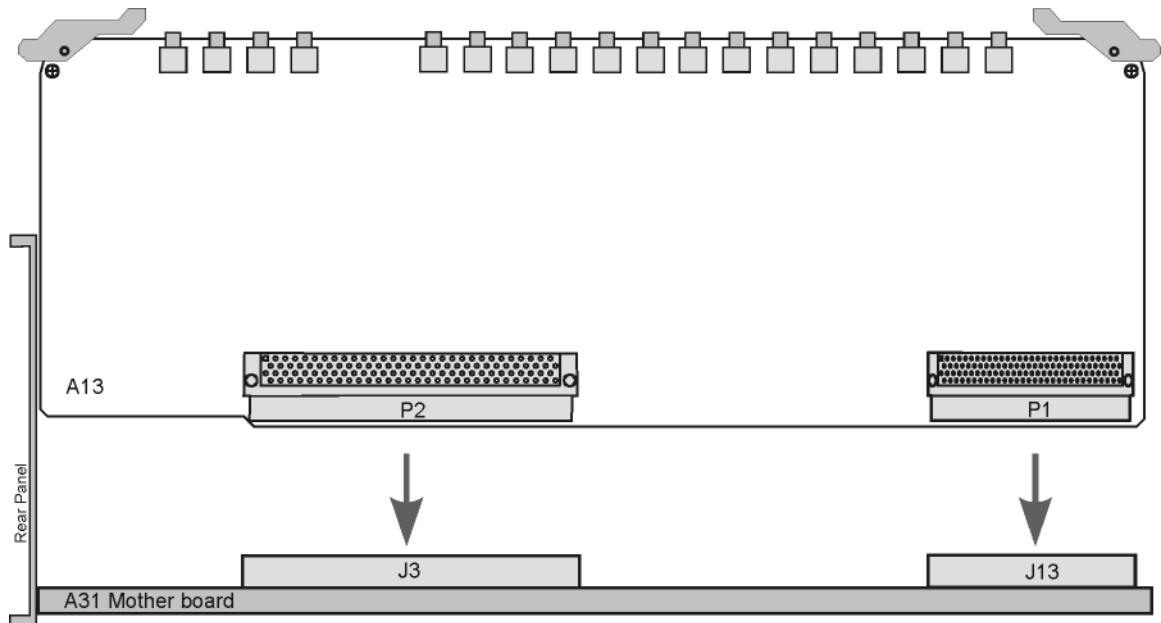

Power Supply Voltage (Vdc)	A31 Motherboard Connector Pins	Minimum (Vdc)	Maximum (Vdc)	Origin
+15	P152 - 28	+14.55	+15.45	Main Supply
-15	P152 - 3	-15.45	-14.55	Main Supply
+5.2	P152 - 27	+5.04	+5.36	Main Supply
-5.2	P152 - 1	-5.36	-5.04	A9 YIG Driver
-5.2 V2	P152 - 26	-5.30	-5.10	A31 Motherboard
+5.2 D	P151 - 64, 65, 129, 130	+5.04	+5.36	Main Supply

100 Power Supply

- If all power supply voltages are good on the A31 Motherboard, replace the A13 I/Q Multiplexer.
- If any of the supply voltages are bad on the A31 Motherboard, check the origin of that supply.

- If the supply voltage is good at the origin, replace the A31 Motherboard.
- If the supply voltage is bad at the origin, troubleshoot the origin.

101 CAL Source

- Replace the A13 I/Q Multiplexer.

102 Ext In Offset DAC and Switch

- Replace the A13 I/Q Multiplexer

103 Path 1 & 2 and Ext Out

- Replace the A13 I/Q Multiplexer

104 Path 1: Attenuators and Summing Amp

- Replace the A13 I/Q Multiplexer

105 Path 2: Attenuators and Summing Amp

- Replace the A13 I/Q Multiplexer

106 DC-Couple Mode, CW bias DAC, Course+Fine DAC

- Replace the A13 I/Q Multiplexer

107 Drift Canceller

- Replace the A13 I/Q Multiplexer

108 IQ Polarity Switch

- Replace the A13 I/Q Multiplexer

109 RMS to DC Converter

- Replace the A13 I/Q Multiplexer.

110 Not Used

111 Wideband Path Test

Use an oscilloscope to check A13 I/Q Multiplexer output.

1. Disconnect the cable from A13J10.
2. Probe A13J10 while executing self test 111, for a square wave, 300 ms at +0.7V and 300 ms at -0.7V.
 - If a square wave is not present on A13J10, replace the A13 I/Q Multiplexer board.
 - If a square wave is present at A13J10, continue to step 3.
3. Reconnect the cable to A13J10.
4. Disconnect the cable from A31J1052.
5. Probe A31J1052 while executing self test 111, for a square wave on the center pin, 300 ms at +0.7V and 300 ms at -0.7V.
 - If a square wave is not present on A31J1052, replace the W132 cable.
 - If a square wave is present at A31J1052, replace the A8 Output board.
6. Disconnect the cable from A13J9.
7. Probe A13J9 while executing self test 111, for a square wave, 300 ms at +0.7V and 300 ms at -0.7V.
 - If a square wave is not present on A13J9, replace the A13 I/Q Multiplexer board.
 - If a square wave is present at A13J9, continue to step 3.
8. Disconnect the cable from A31J1053.
9. Probe A31J1053 while executing self test 111, for a square wave on the center pin, 300 ms at +0.7V and 300 ms at -0.7V.
 - If a square wave is not present on A31J1053, replace the W131 cable.
 - If a square wave is present at A31J1053, replace the A8 Output board.

Self-Tests 2xx: A5 Sampler Self-Test Errors

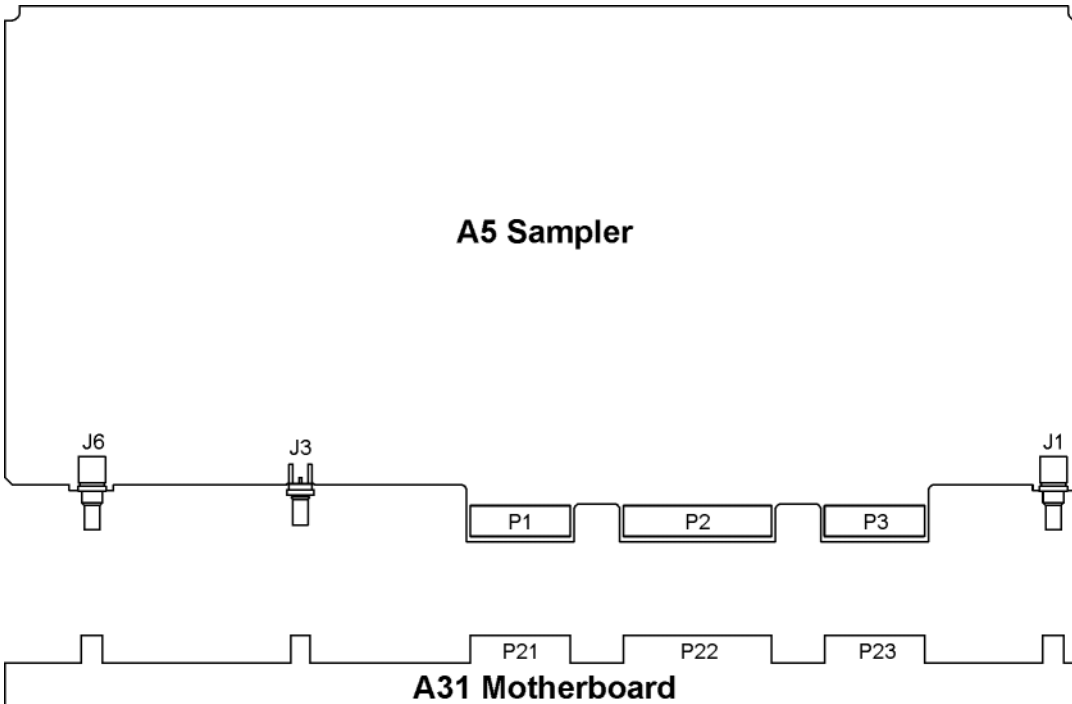

Before proceeding to the reported self-test error code, check the following voltages. If any voltages are out of specification, troubleshoot the supply problem first.

Supply Voltage (Vdc)	Connector Pins	Minimum Value (Vdc)	Maximum Value (Vdc)	Origin
+32	P22-7	+31.04	+32.96	Main Supply
+15	P22-6, 21	+14.55	+15.45	Main Supply
-15	P22-2, 17	-14.55	-15.45	Main Supply
+5.2	P22-14, 29	+5.04	+5.37	Main Supply
+9	P22-5, 20	+8.82	+9.18	YIG Driver

200 Power Supply

1. If the supply voltages are good on the connector pins indicated, replace the A5 Sampler.
2. If the supply voltages are bad on any of the connector pins indicated, check the origin of the supply.
3. If the supply voltages are good at the origin, replace the A31 Motherboard.

4. If the supply voltages are bad at the origin, troubleshoot the problem using that assembly's troubleshooting procedure.

201 Tuning + Bias Test

1. Turn power off and remove the A5 Sampler and connect a signal analyzer to the A5 Sampler J1 input cable on the A31 Motherboard.
2. Turn the signal generator on and check for the presence of a 1 GHz signal at the level of 0 dBm.
3. If the signal is good on the cable connector J1, replace the A5 Sampler.
4. If the signal is bad, remove the A7 Reference and ohm the cable between the center pins (a short should occur) and between the center pins and shielding (an open should occur) of J3 on the A7 Reference and J1 on the A5 Sampler.
5. If an open is measured between the center pins or a short between center pins and the shielding, replace the cable.
6. If the cable is good, replace the A7 Reference.

202 Coarse Loop Detector

1. Replace the A5 Sampler

203 YO Loop Detector

1. With power on carefully remove the A5 Sampler, connect a signal analyzer to J3 on the A31 Motherboard. Set the signal generator to 8 GHz CW then check for an 8 GHz signal at a power level greater than or equal to -7 dBm on J3.
2. If the J3 signal is bad, troubleshoot the A29 20 GHz Doubler using the procedure in the RF path section. If the J3 signal is good, go to the next step.
3. Connect the signal analyzer to the A6 Frac-N VCO signal on the J6 connection on the A31 Motherboard. With the signal generator set to 8 GHz CW, the A6 Frac-N signal should be at a frequency of 593.75 MHz and at a power level of +7 dBm.
4. If the signal is good, replace the A5 Sampler, if the signal is bad go to the A6 Frac-N troubleshooting procedure.

Self-Tests 3xx: A7 Reference (Standard) Self-Test Errors (For instruments with serial prefixes < US4805/MY4805)

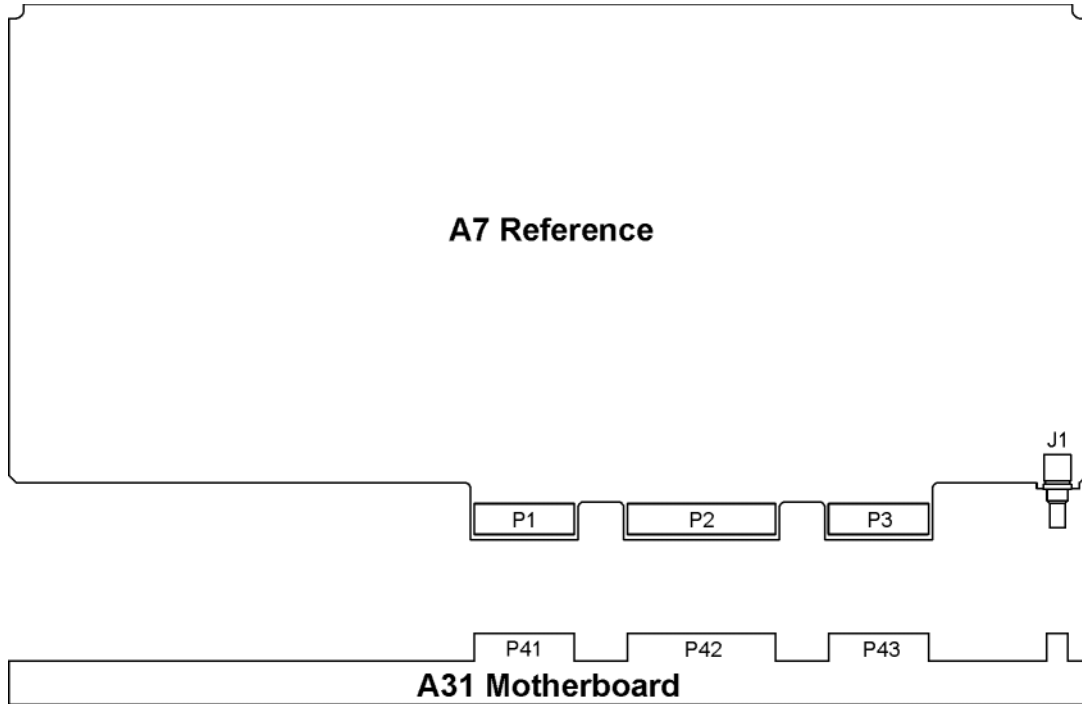

Before proceeding to the reported self-test error code, check the following voltages. If any of the voltages are out of specification, troubleshoot the supply problem first.

Supply Voltage (Vdc)	Connector Pins	Minimum Value (Vdc)	Maximum Value (Vdc)	Origin
+32	P102-7	+31.04	+32.96	Main Supply
+15	P102-6, 21	+14.55	+15.45	Main Supply
-15	P102-2, 17	-14.55	-15.45	Main Supply
+5.2	P102-14, 29	+5.04	+5.37	Main Supply
+9	P102-5, 20	+8.82	+9.18	YIG Driver

300 1 GHz Detector

1. Check and remove any connection to the 10 MHz external reference on the rear panel.
2. If the signal generator continues to fail self-test, replace the A7 Reference.

301 Tuning Voltage

1. Replace the A7 Reference.

Self-Tests 4xx: A8 Output Self-Test Errors (E8267D only)

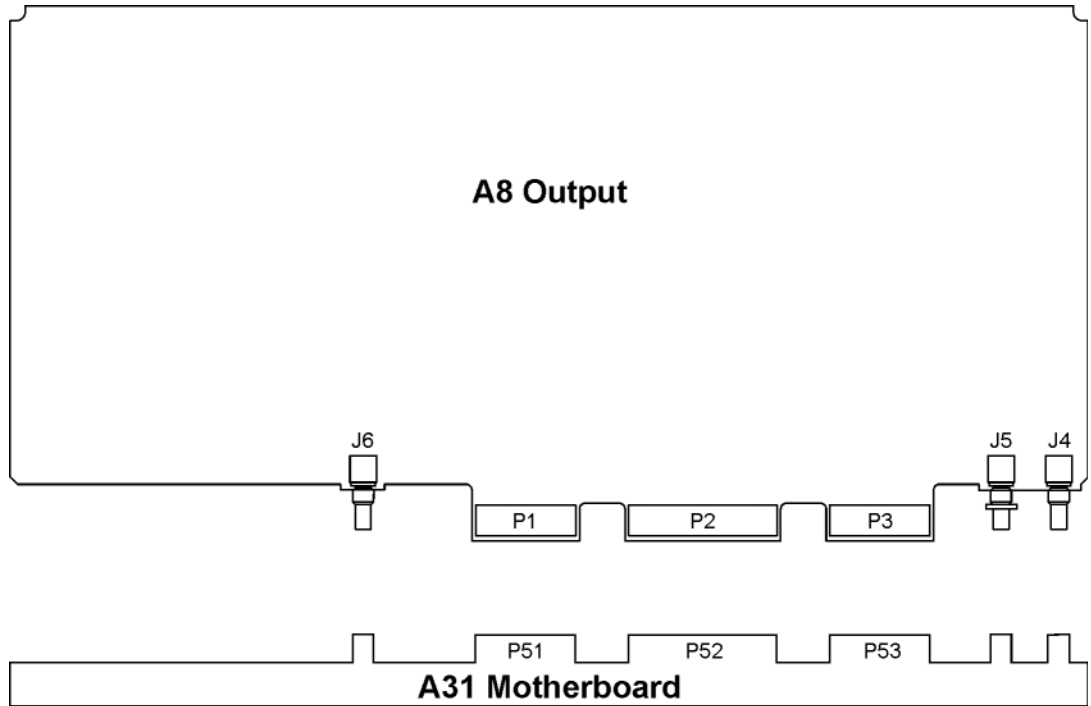

Before proceeding to the reported self-test error code, check the following voltages. If any voltages are out of specification, troubleshoot the supply problem first.

Supply Voltage (Vdc)	Connector Pins	Minimum Value (Vdc)	Maximum Value (Vdc)	Origin
+15	P52-6, 21	+14.55	+15.45	Main Supply
-15	P52-2, 17	-15.45	-14.55	Main Supply
+5.2	P52-14, 29	+5.04	+5.36	Main Supply
+9	P52-5, 20	+8.82	+9.18	YIG Driver
-6	P52-3, 18	-6.12	-5.88	YIG Driver

400 Lowband Ground and PTAT Test

- Replace A8 Output.

401 Prelevel Loop Test

1. With the signal generator powered up, carefully remove the A8 Output.
2. Set the signal generator to 3 GHz CW.
3. Using a spectrum analyzer measure the A6 Frac-N RF output at J4 of the A8 Output.

The signal at J4 should be at 3 GHz and ≥ 0 dBm.

- If the signal is not present, or is not at the correct level, replace the A6 Frac-N.
- If the signal is present, replace the A8 Output.

WARNING

Do not re-install the A8 Output with the signal generator turned on, or serious damage to the signal generator can result.

402 Quadrature DAC Test

- Replace the A8 Output.

403 VBLO Test

- Replace the A8 Output.

404 Marble Test

1. Measure the Q signal from the A13 I/Q Multiplexer:
 - a. Disconnect the cable from J1052 A31 Motherboard and connect it to a DVM.
 - b. Set the CW frequency to 2 GHz.
 - c. Turn on the I/Q modulation, and make the Q offset the active function:
 1. Press the I/Q hardkey.
 2. Select **I/Q On > I/Q Adjustments > I/Q Adjustments On > Q Offset**
 - d. As you rotate the RPG, the voltage displayed on the DVM should vary from approximately +0.25 Vdc for an offset of 50%, to approximately -0.25 Vdc for an offset of -50%.

If the signal is bad, check it at J10 of the A13 I/Q Multiplexer.

- If the signal is bad at J10, refer to the A13 I/Q Multiplexer troubleshooting, on [page 39](#).
- If the signal is good at J10, change the cable.

2. Measure the I signal from the A13 I/Q Multiplexer:

- a. Reconnect the cable removed in **Step 1**
- b. Disconnect the cable from J1053 A31 Motherboard and connect it to the DVM.
- c. Leave the I/Q modulation on, and make the I offset the active function.
- d. As you rotate the RPG, the voltage displayed on the DVM should vary from approximately +0.25 Vdc for an offset of 50%, to approximately -0.25 Vdc for an offset of -50%.

If the signal is bad, check it at J9 of the A13 I/Q Multiplexer.

- If the signal is bad at J9, refer to the A13 I/Q Multiplexer troubleshooting, on **page 39**.
 - If the signal is good at J9, change the cable.
3. If both the I and Q signals are good, reconnect the cable removed in **Step 2**
Check the signals at the A8 Output board.
 - a. At J53-8, repeat the Q offset check in **Step 1**
 - If the signal is good, replace the A8 Output board.
 - If the signal is bad, replace the A31 Motherboard.
 - b. At J53-19, repeat the I offset check in **Step 2**
 - If the signal is good, replace the A8 Output board.
 - If the signal is bad, replace the A31 Motherboard.

405 Gain Adjustment Test

- Replace the A8 Output.

406 Prelevel Bypass Test

- Replace the A8 Output.

407 Switched Filters Test

- Replace the A8 Output.

408 ALC Reference DAC Test

- Replace the A8 Output.

409 ALC Modulation Test

- Replace the A8 Output.

410 Burst Mod Driver Test

- Replace the A8 Output.

411 ALC Detector Test

- Replace the A8 Output.

412 Het Band Test

Measure the 1 GHz signal from the A7 Reference board:

1. Turn on the signal generator.
2. Set CW = 200 MHz.
3. Using a spectrum analyzer, probe P51-19.

There should be a 1 GHz signal, that is >-30 dBm.

- If the signal is good, replace the A9 Output.
- If the signal is not good, run the A7 self-tests.

Self-Tests 6xx: A9 YIG Driver Self-Test Errors

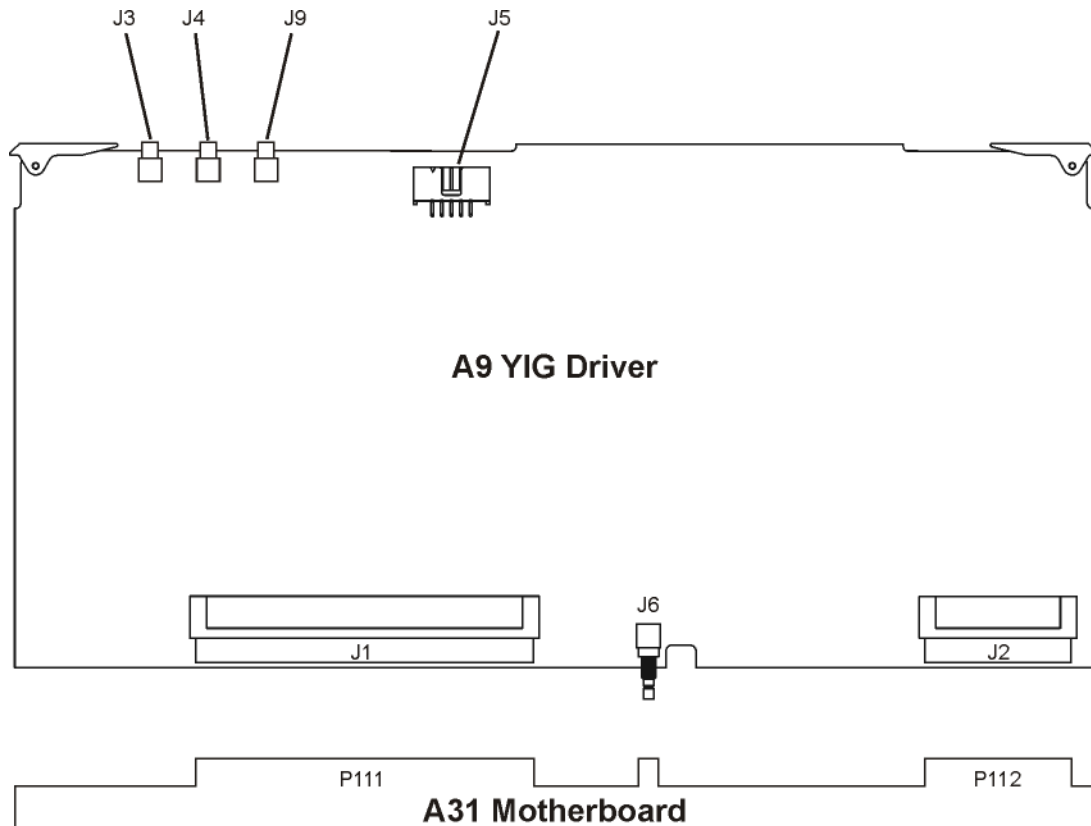

Before proceeding to the reported self-test error code, check the following voltages. If any are out of specification, troubleshoot the supply problem first.

Supply Voltage (Vdc)	Connector Pins	Minimum Value (Vdc)	Maximum Value (Vdc)	Origin
+32	P112-6	+31.04	+32.96	Main Supply
+15	P112-5, 30	+14.55	+15.45	Main Supply
-15	P112-4, 29	-14.55	-15.45	Main Supply
+5.2	P112-3, 28	+5.04	+5.37	Main Supply
+10	P112-15, 16, 40	+10	+10.4	Main Supply
-7	P112-11, 12, 13, 14, 38	-6.86	-7.14	Main Supply
+5.2 Digital high	P111-64, 65, 129, 130	+5.04	+5.36	Main Supply
+3.4 Digital Low	P111-60, 61, 62, 63, 125, 126, 127, 128	+3.29	+3.5	Main Supply

A9 YIG Driver Output Voltages

If any of the following voltages are out of specification, replace the A9 YIG Driver:

Supply Voltage (Vdc)	Connector Pins	Minimum Value (Vdc)	Maximum Value (Vdc)
+9	P112-17, 18, 42	+8.82	+9.18
-5.2	P112-1, 2, 26, 27	-5.1	-5.3
-6	P112-19, 44	-5.88	-6.12

600 Post Regulator

- Replace the A9 YIG Driver.

601 DACs

- Replace the A9 YIG Driver.

602 PLL Interface

1. Remove the cable that goes from the A5 Sampler to J4 on the A9 YIG Driver.
2. Loop self-test 602, and use an oscilloscope to measure the voltage on J4. The voltage should pulse to +10 Vdc.
 - If the voltage is +10 Vdc, replace the A9 YIG Driver.
 - If the voltage on J4 is bad, replace the A5 Sampler.

603 FM Driver

1. Remove the cable that goes from the A6 Frac-N to J3 on the A9 YIG Driver.
2. Loop self-test 603, and use an oscilloscope to measure the voltage on J3. The voltage should be approximately -1.3 Vdc.
 - If the voltage is approximately -1.3 Vdc, replace the A9 YIG Driver.
3. If the voltage is bad at J3, check it entering the A6 Frac-N at P31-11.

The voltage on J3 originates on the A11 Pulse/Analog Modulation Generator and passes through the A6 Frac-N.

- If the voltage is good entering the A6 Frac-N, troubleshoot the A6 Frac-N.
- If the voltage is bad at P31, troubleshoot the A11 Pulse/Analog Modulation Generator.

604 Sweep DACs

- Replace the A9 YIG Driver.

605 Sweep Lock

1. Using an oscilloscope with high input impedance, measure the center pin of J9 on the A9 YIG Driver.

Source Setup		Oscilloscope Setup
Start:	5 GHz	10 ms/div
Stop:	10 GHz	5V/div
Sweep:	Freq	1 M Ω
Sweep Time:	Auto	
Sweep Repeat:	Continuous	

A positive and negative going signal should be present.

- If the signal is present at J9, replace the A9 YIG Driver.
2. If the signal is not present at J9, measure the center pin of J1032 on the motherboard.
 - If the signal is present, replace the cable.
 - If the signal is not present, replace the A6 Frac-N.

Self-Tests 7xx: A6 Frac-N Self-Test Errors

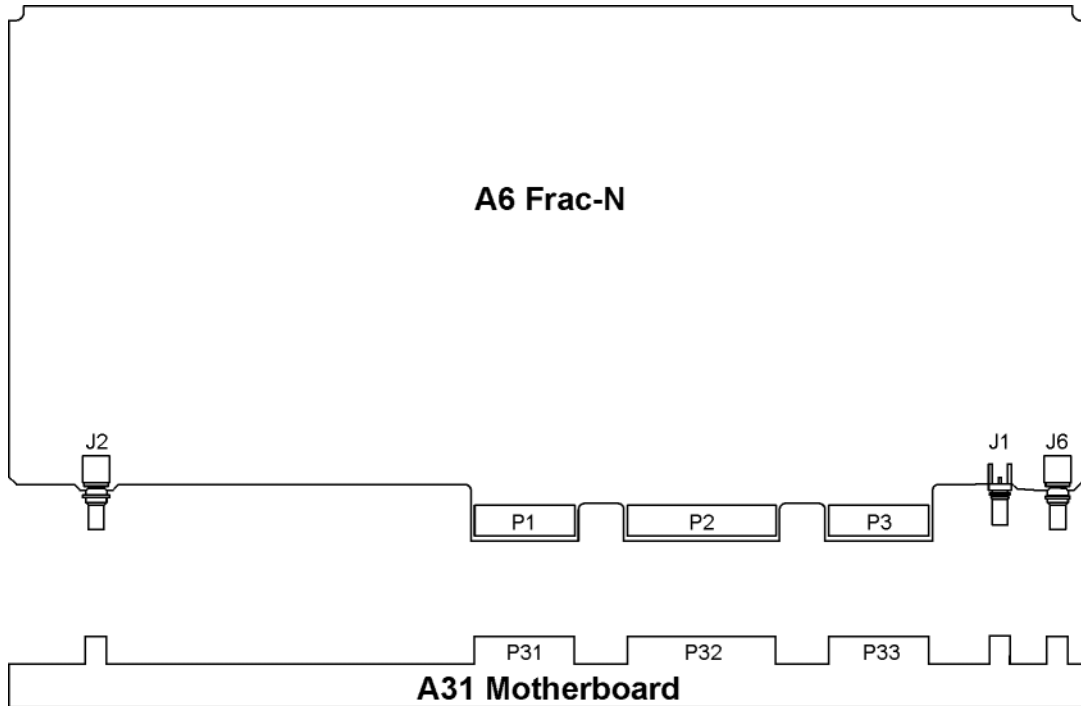

Before proceeding to the reported self-test error code, check the following voltages. If any voltages are out of specification, troubleshoot the supply problem first.

Supply Voltage (Vdc)	Connector Pins	Minimum Value (Vdc)	Maximum Value (Vdc)	Origin
+32	P32-7	+31.04	+32.96	Main Supply
+15	P32-6, 21	+14.55	+15.45	Main Supply
-15	P32-2, 17	-14.55	-15.45	Main Supply
+5.2	P32-14, 29	+5.04	+5.37	Main Supply
+9	P32-5, 20	+8.82	+9.18	YIG Driver
-5.2	P32-4, 19	-5.1	-5.3	YIG Driver
-6	P32-3, 18	-5.88	-6.12	YIG Driver

700 Ref Voltage

- Replace the A6 Frac-N.

701 Loop Gain

- Replace the A6 Frac-N.

702 Tuning Voltage

1. Using an oscilloscope, check 10 MHz Synthesis line on P33–15. The signal period should be 100 ns with an amplitude of approximately $3V_{pp}$.
 - If the signal is good, replace the A6 Frac–N.
2. If the signal is bad, turn the signal generator power off, remove the A6 Frac–N, and measure the signal at P33–15 again.
 - If the signal is good, replace the A6 Frac–N.
3. If the signal is still bad, measure P41–5 on the A7 Reference.
 - If the signal is good at P41–5, replace the A31 Motherboard.
 - If the signal is bad at P41–5, replace the A7 Reference.

703 Output Voltage

1. Using an oscilloscope, check 10 MHz Synthesis line on P33–15. The signal period should be 100 ns with an amplitude of approximately $3V_{pp}$.
 - If the signal is good, replace the A6 Frac–N.
2. If the signal is bad, turn the signal generator power off, remove the A6 Frac–N, and measure P33–15 again.
 - If the signal is good, replace the A6 Frac–N.
3. If the signal is still bad, measure P41–5 on the A7 Reference.
 - If the signal is good at P41–5, replace the A31 Motherboard.
 - If the signal is bad at P41–5, replace the A7 Reference.

704 Filter Test

1. Refer to [Table 1-13](#), and check J1 on the A6 Frac–N:
 - a. Turn the signal generator on and remove the A6 Frac–N.
 - b. Set the signal generator to the first center frequency.
 - c. Use an extender board cable to connect a spectrum analyzer to J1.
 - d. Tune the spectrum analyzer to the first J1 frequency, and check for the correct power.
 - e. Repeat Step d for the remaining frequencies.

- If **all** the signals at J1 are good, continue with **Step 3**.

Table 1-13

Center Frequency (GHz)	J1 Frequency (GHz)	Power at J1 (dBm)
0.300	4.771	> -6
0.500	7.969	
0.750	5.971	
1.25	4.976	
2.0	7.969	
3.0	5.971	

2. If **any** signal measured in Step 1 is bad, check the signal out of the A6 Frac-N output port on the A29 20 GHz Doubler.
 - If the signal out the A29 20 GHz Doubler is good, replace the cable.
 - If the signal out the A29 20 GHz Doubler is bad, replace the A29 20 GHz Doubler.
3. If all of the signals at J1 are good, turn the signal generator off and reinstall the A6 Frac-N.
4. Check J4 at the A8 Output (shown on [page 79](#)):
 - a. Power the signal generator on and remove the A8 Output.
 - b. Use an extender cable to connect a spectrum analyzer to J4.
 - c. Tune the spectrum analyzer to the first frequency in column one of [Table 1-13](#), and check for approximately +10 dBm.
 - If an RF signal is present on J4, replace the A8 Output.
 - If an RF signal is not present on J4, replace the A6 Frac-N.

705 F/2 Test

1. Using an oscilloscope, check the 10 MHz Synthesis line on P33-15. The signal period should be 100 ns with an amplitude of approximately $3V_{pp}$.
 - If the signal is good, replace the A6 Frac-N.
2. If the signal is bad, turn the signal generator power off, remove the A6 Frac-N, and measure P33-15 again.
 - If the signal is good, replace the A6 Frac-N.
3. If the signal is still bad, measure P41-5 on the A7 Reference.
 - If the signal is good at P41-5, replace the A31 Motherboard.

- If the signal is bad at P41–5, replace the A7 Reference.

706 FM Path Test

1. Using an oscilloscope, check P31–22 (FM_On_H):
 - a. Loop self-test 706
 - b. Check for a TTL transition from 0 Vdc to +5 Vdc.
 - If the signal is not present, refer to A5 Sampler troubleshooting.
2. If the signal is present, check P31–11 (FM):
 - a. Loop self-test 706.
 - b. Check for a 0 to 3.3 Vdc transition.
 - If the signals is present, replace the A6 Frac–N.
 - If the signal is not present, refer to A11 Pulse/Analog Modulation Generator troubleshooting.

707 Sweep Phase Detector Test

1. Replace the A6 Frac–N.

Self-Tests 7xx: A45 Frac–N Self-Test Errors (option UNY)

720 Ref Voltage Test

- Replace the A45.

721 1 GHz Input Test

Disconnect the cable W155 from the Frac–N A45J4 and connect to a signal analyzer. Check for 1 GHz and its power, approximately 0 dBm.

- If the signal is present, replace A45.
- If the signal is not present, replace W155 or A46.

722 Open Loop VCO Test

- Replace the A45.

723 Open Loop F/2 Test

- Replace the A45.

724 Close Loop VCO Test

- Replace the A45.

725 Low Band Filter Test

- Replace the A45.

Self-Tests 9xx: A10 ALC Self-Test Errors

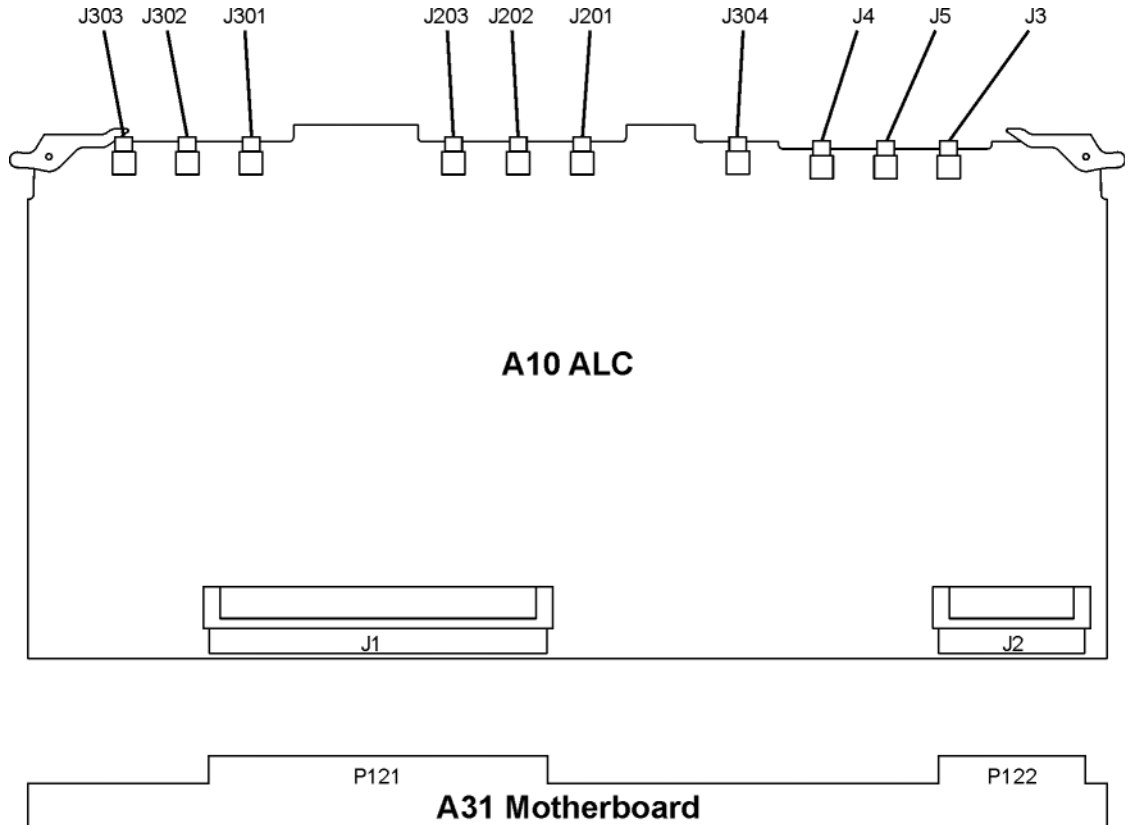

Before proceeding to the reported self-test error code, check the following voltages. If any voltages are out of specification, troubleshoot the supply problem first.

Supply Voltage (Vdc)	Connector Pins	Minimum Value (Vdc)	Maximum Value (Vdc)	Origin
+32	P122-4	+31.04	+32.96	Main Supply
+15	P122-28	+14.55	+15.45	Main Supply
-15	P122-3	-14.55	-15.45	Main Supply
+5.2	P122-2, 27	+5.04	+5.37	Main Supply
-5.2	P122-1, 26	+5.30	+5.10	YIG Driver

Supply Voltage (Vdc)	Connector Pins	Minimum Value (Vdc)	Maximum Value (Vdc)	Origin
+5.2 Digital high	P121-64, 65, 129, 130	+5.04	+5.36	Main Supply
+3.4 Digital Low	P121-60, 61, 62, 63, 125, 126, 127, 128	+3.29	+3.5	Main Supply

900 Power Supply

- Replace the 10 ALC assembly.

901 Detector Test

1. Using a digital voltmeter, check J3 for approximately -0.29 Vdc:
 - a. Turn the signal generator's RF power on.
 - b. Set the frequency to 10 GHz and the RF power level to +20 dBm, ALC off.
 - c. Disconnect the cable from J3 of the A10 ALC (W15) and connect the cable to the voltmeter.
 - If the signal is not present, refer to highband RF loop troubleshooting.
 - If the signal is present, replace the A10 ALC.

902 Detector Level to ALC Ref

1. Using a digital voltmeter, check J5 for -2.3 Vdc:
 - a. Turn the signal generator's RF power on.
 - b. Set the frequency to 1 GHz and the RF power level to +20 dBm, ALC off.
 - c. Disconnect the cable from J5 of the A10 ALC (W14) and connect the cable to the voltmeter.
 - If the signal is not present, refer to lowband RF loop troubleshooting.
2. If the signal is present, check J3 for -0.29 Vdc:
 - a. On the signal generator, change the frequency to 10 GHz.
 - b. Disconnect the cable from J3 of the A10 ALC (W15) and connect the cable to the voltmeter.
 - If the signal is not present, refer to highband RF loop troubleshooting.
 - If the signal is present, replace the A10 ALC.

903 Level Test

1. Using a digital voltmeter, check J3 for -0.29 Vdc:
 - a. Turn the signal generator's RF power on.
 - b. Set the frequency to 10 GHz and the RF power level to +20 dBm.
 - c. Disconnect the cable from J3 of the A10 ALC (W15) and connect the cable to the voltmeter.
 - If the signal is not present, refer to highband RF loop troubleshooting.
 - If the signal is present, replace the A10 ALC.

904 Scalar Mod Pulse

- Replace the A10 ALC.

905 ALC Mod Test

- Replace the A10 ALC.

906 Scan Mod Test

- Replace the A10 ALC.

Self-Tests 10xx: A7 Reference (Option UNR/UNX and Instruments with Serial Prefixes \geq US4805/MY4805) Self-Test Errors

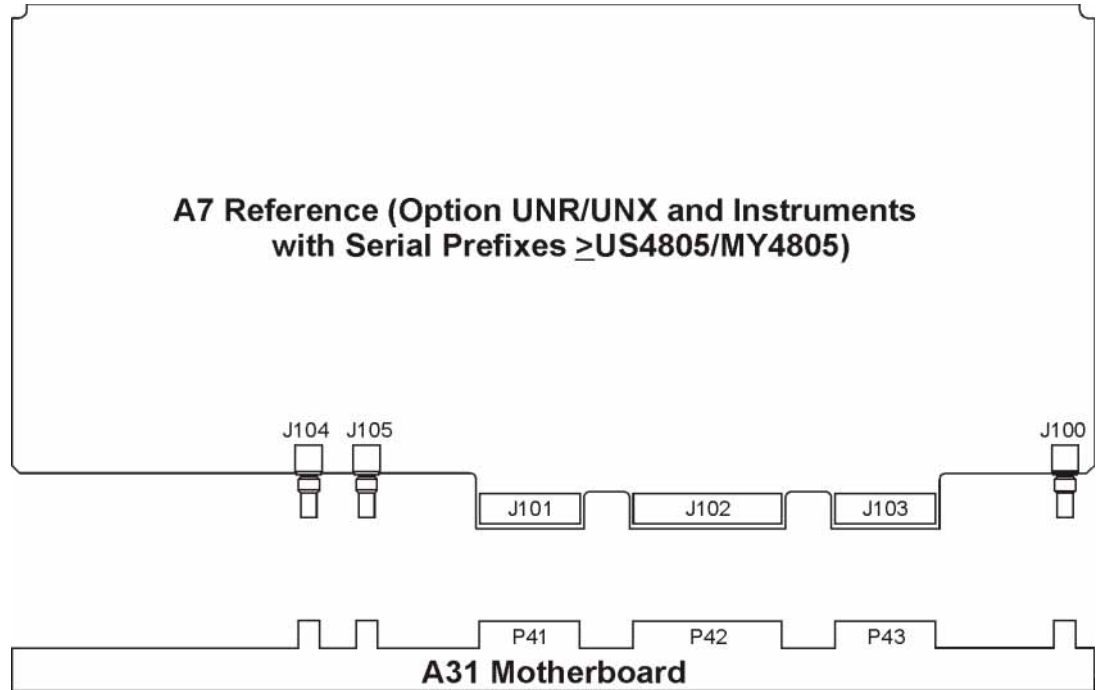

Before proceeding to the reported self-test error code, check the following voltages. If any voltages are out of specification troubleshoot the supply problem first.

Supply Voltage (Vdc)	Connector Pins	Minimum Value (Vdc)	Maximum Value (Vdc)	Origin
+15	P42-6, 21	+14.55	+15.45	Main Supply
-15	P42-2, 17	-14.55	-15.45	Main Supply
+9	P42-5, 20	+8.82	+9.18	YIG Driver

1000 Power Supply

- Replace the A7 Reference.

1001 10 MHz Test

1. Using an oscilloscope, check P41-2 for a 10 MHz signal greater than 1.12 V_{p-p}. If the signal is present, replace the A7 Reference.
2. If the signal is not present, the problem could be the 10 MHz Reference or the signal path from the 10 MHz Reference.

3. Check the 10 MHz reference oscillator output signal.
 - a. If the 10 MHz signal is not present on the output port, measure the 10 MHz power supply voltages on the rear panel interface board. The following voltages should be observed:
 - Pin 1 ground
 - Pin 2 +12V
 - Pin 3 ground
 - Pin 4 a positive DC voltage around +3.8V should be present (oven cold raw voltage may vary).
 - b. If the power supply voltages are good, replace the 10 MHz reference.
 - c. If the power supply voltages are bad, replace the rear panel interface board.
4. If the 10 MHz signal is present out of the reference oscillator, but not on the A31 mother board at P41-2, reconnect the cable going to the 10 MHz signal.
 - a. Measure the end of the cable going to the A31 mother board at J1041.
 - b. If the signal is bad, replace the cable.
 - c. If the signal is good, go to **Step 5**.
5. Measure the ohmic resistance between the J1041 center pin and P41-2 and the J1041 center pin to ground.
 - a. If the trace is open or shorted to ground, replace the A31 mother board.
 - b. If the J1041 is not shorted to ground and the J1041 to P41-2 is not open, remove the A7 board and measure P41-2.
 - c. If the signal is now present, replace the A7 board.
 - d. If the signal is still missing, replace the A31 mother board.

1002 1 GHz Test

- Replace the A7 Reference.

Self-Tests 11xx: A18 CPU Self-Test Errors

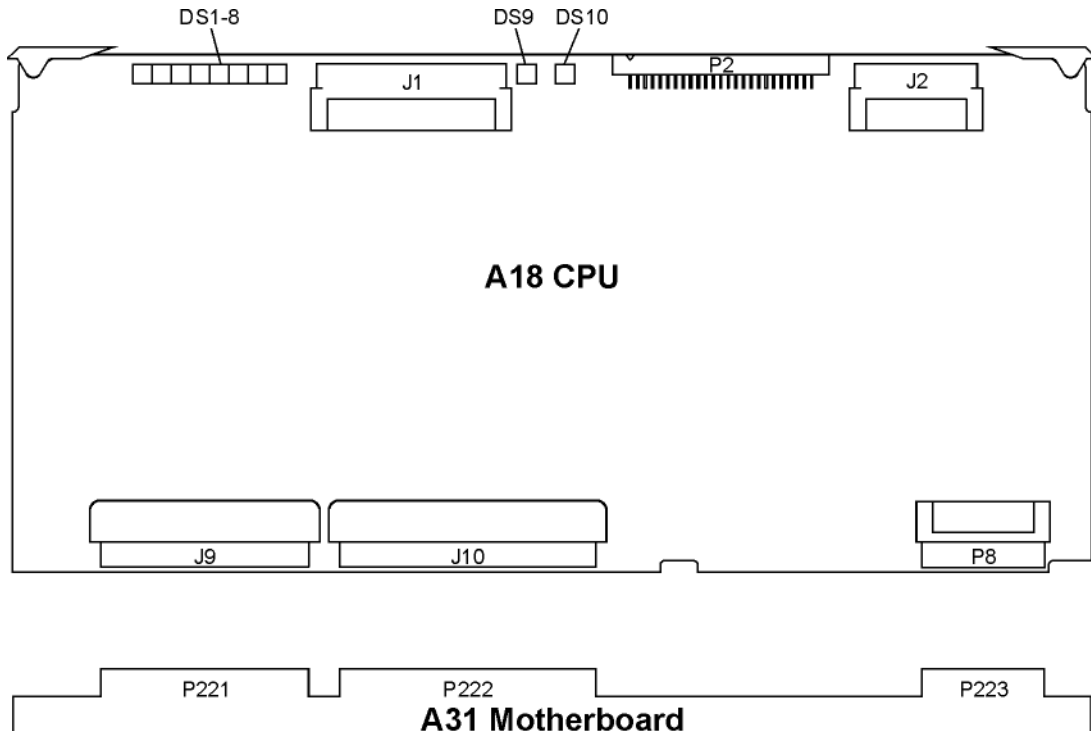

1100 Power Supply

The A18 CPU self-test verifies the presence of the supplies listed. These supplies are not checked during the turn-on check and are not necessary for the turn-on check to pass.

1. After running self-test, View **Details** and see which supply failed.
2. If the 10 VRef has failed, replace the A18 CPU. The 10 VRef is generated on the A18 CPU and used for the ADC circuit.
3. For a self-test failure other than the 10 VRef, measure the appropriate connector pin listed in the following table.

Connector P223	Supply Voltage	Voltage Range
Pin 1	-5.2 Vdc	-5.2 \pm .1 Vdc
Pin 17	-6 Vdc	-6 \pm .12 Vdc
Pin 18	+9 Vdc	+9 \pm .18 Vdc

4. If the voltages are present on the A31 Motherboard, turn power off, remove the A18 CPU and inspect the connector. If the pins look good, replace the A18 CPU.
5. If a supply voltage is not present on the connector, measure the appropriate point listed in the following table:

Connector P112	Supply Voltage	Voltage Range
Pin 1, 2, 26, 27	-5.2 Vdc	-5.2 ± 0.1 Vdc
Pin 19, 44	-6 Vdc	-6 ± 0.12 Vdc
Pin 17, 18, 42	+9 Vdc	+9 ± 0.18 Vdc

6. If the voltage is present on P112 but not present on P223, replace the A31 Motherboard.
7. If the voltages are not present on P112, troubleshoot the A9 YIG Driver.

Self-Tests 12xx: A26 MID Self-Test Errors (E8257D)

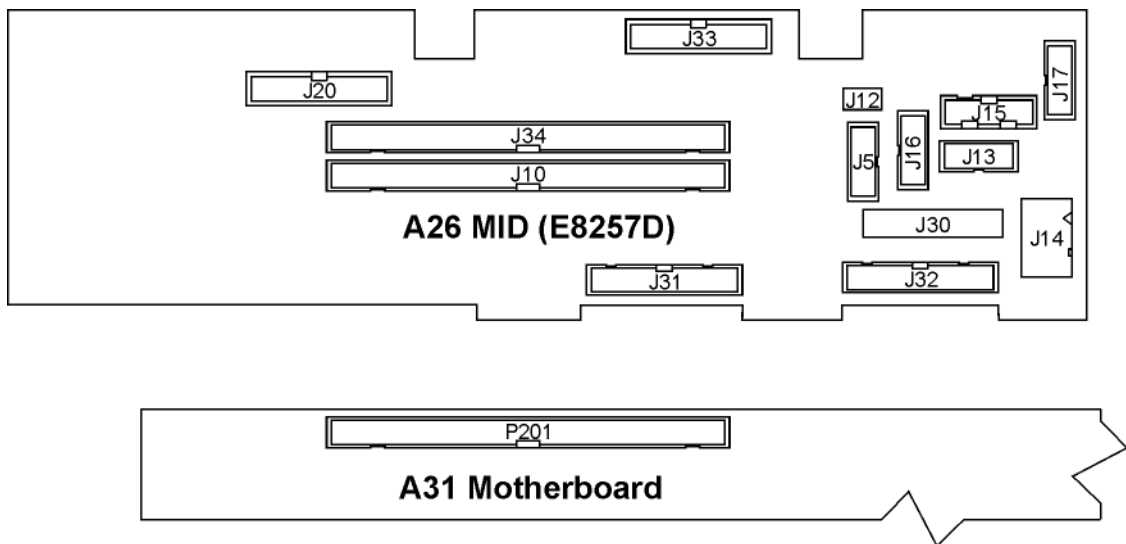

Before proceeding to the reported self-test error code, check the following voltages in. If any of these voltages are out of specification, troubleshoot the supply problem first.

Supply Voltage (Vdc)	E8257D Connector Pins	All Other Models Connector Pins	Minimum Value (Vdc)	Maximum Value (Vdc)	Origin
+32	P201-11	P201-1	+31.04	+32.96	Main Supply
+15	P201-12, 13, 14	P201-2, 3, 4	+14.55	+15.45	Main Supply
-15	P201-21, 22	P201-11, 12	-15.45	-14.55	Main Supply
+5.2	P201-7, 8, 9, 10, 23, 24, 25, 26, 27, 28	P201-13, 14, 15, 16, 17, 18	+5.04	+5.36	Main Supply
+10	P201-15, 16, 17, 18, 19, 20	P201-5, 6, 7, 8, 9, 10	+9.7	+10.3	Main Supply
+8	P201-39	P201-29	+7.5	+8.5	MID
-7	P201-40, 43, 56	N/A	-7.21	-6.79	Main Supply
-5.2	P201-41, 42	P201-31, 32	-5.30	-5.10	YIG Driver
+5.2 Digital high	P201-33	P201-23	+5.04	+5.36	Main Supply
+3.4 Digital Low	P201-34	P201-24	+3.3	+3.5	Main Supply

1200 Power Supply

1. Press **View Test Info** and highlight Self Test 1200. Press **View Details**.
2. From the displayed self-test results, determine which supply or supplies failed.
3. Refer to the following table; disconnect one microcircuit at a time and run self-test 1200.

Microcircuit	A26 MID Connector	+12V	+8V	+6.5V	+3.5V	-3V
A30 Modulation Filter	J31	✓	✓			
A29 20 GHz Doubler	J32	✓	✓			
A27 40 GHz Doubler	J33		✓			
A36 Quadraplier	J34			✓	✓	✓

- If the test passes after disconnecting one or more microcircuits, replace the microcircuit.
- If self-test still fails after disconnecting all the microcircuits, replace the A26 MID.

1201 Mod Filter

1. Disconnect the cable between the A23 Lowband Coupler/Detector and the A30 Modulation Filter, and connect a spectrum analyzer to the cable.

2. Tune the source across the lowband frequencies (250 kHz to 3.2 GHz) and record the lowest power level.
3. Disconnect the cable coming from the A29 20 GHz Doubler, and connect the spectrum analyzer to this cable.
4. Tune the source across the A29 20 GHz Doubler band of frequencies (3.2 GHz to 20 GHz) and record the lowest power level.
5. Determine the expected levels using the tools described in [“Troubleshooting RF Power Levels” on page 106](#), and compare them to the measured levels.
 - If the power level in both paths is good, replace the A30 Modulation Filter.
 - If the power level in **either** path is bad, troubleshoot that path.
 - If the power level in both paths is bad, check the signal levels out of the A28 YIG Oscillator.

1202 A29 20 GHz Doubler

1. Disconnect the cable between the A28 YIG Oscillator and the A29 20 GHz Doubler, and connect a spectrum analyzer to the cable.
2. Tune the source frequency across the A28 YIG Oscillator range (3.2 GHz to 10 GHz) noting the lowest power level.
3. Determine the expected levels using the tools described in [“Troubleshooting RF Power Levels” on page 106](#), and compare them to the measured levels.
 - If the power level is good, replace the A29 20 GHz Doubler.
 - If the power level is bad, replace the A28 YIG Oscillator.

1203 40 GHz Doubler (Option 540)

1. Disconnect the 0 to 20 GHz cable between the A30 Modulation Filter and the A27 40 GHz Doubler, and connect a spectrum analyzer to the cable.
2. Tune the source from 250 kHz to 20 GHz, and record the lowest power level.
3. Disconnect the 10 to 20 GHz cable that comes from the A30 Modulation Filter, and connect the spectrum analyzer to this cable.
4. Tune the source from 20 GHz to 40 GHz, recording the lowest power level.
5. Determine the expected levels using the tools described in [“Troubleshooting RF Power Levels” on page 106](#), and compare them to the measured levels.
 - If both power levels are good, replace the A27 40 GHz Doubler.
 - If either power level is bad, troubleshoot the path.

1204 RF Path

This test checks for a dc voltage on the A10 ALC from the A23 Lowband Coupler/Detector and A24 Highband Coupler and A25 Highband Detector.

1. Connect a spectrum analyzer to the RF output of the signal generator.
2. Turn the RF power on and verify the presence of an RF signal on the output.
 - If no RF signal is present, troubleshoot the RF path problem (see [“Troubleshooting the RF Path” on page 106](#)).
3. If an RF signal is present on the RF output, set the signal generator to 4 GHz and 0 dBm.
4. Measure the dc voltage on the cable going to J3 of the A10 ALC. The signal should be > -600 mV.
 - If the signal at J3 is good, go to step 6.
5. If no dc signal is present on the cable to J3, check the output at the highband detector.
 - If the signal is good at the detector, replace the cable.
 - If no signal is present at the output of the highband detector, replace the highband detector.
6. If the signal at J3 is good, set the signal generator’s frequency to <1 GHz, the power to 0 dBm, and measure the dc voltage on the cable going to J5 on the A10 ALC.
 - If the dc voltage is -5.25 Vdc, replace the A10 ALC.
7. If other dc voltages are present, check for dc voltage on the output of the lowband detector.
 - If a dc voltage is present, replace the cable.
 - If no dc voltage is present, replace the lowband detector.

1205 LB Pulse Mod

Lowband Pulse On

1. Disconnect the cable from J5 of A10 ALC, and connect the cable to a DVM (this is the lowband detector output).
2. On the signal generator, set the following:
 - Center Frequency: 3 GHz
 - Power: +20 dBm
 - Pulse Modulation: On

Period: 40s
Pulse Width: 10 ns
RF: On

3. The voltage measured by the DVM should be approximately 0V. If it is not, use an oscilloscope to view P131-6 of the A31 Motherboard (this is the pulse signal out of the A11 Pulse/Analog Modulation Generator).

Change the pulse period to 1 ms and the pulse width to 500 μ s.

- If the pulse is not present, perform the A11 Pulse/Analog Modulation Generator self-test, and follow the troubleshooting procedure.
4. If pulse modulation is working, perform the A8 Output self-test.
 - If the self-test passes, refer to [“Troubleshooting the RF Path” on page 106](#), and check the lowband path.
 - If the self-test fails, refer to the A8 Output test troubleshooting.

Lowband Pulse Off

1. Disconnect the cable from J5 of A10 ALC, and connect the cable to a DVM (this is the lowband detector output).

2. On the signal generator, set the following:

Center Frequency: 3 GHz
Power: +20 dBm
Pulse Modulation: On
Period: 40s
Pulse Width: 39.9s
RF: On

3. The voltage measured by the DVM should be approximately -2.2 V. If it is not, use an oscilloscope to view P131-6 of the A31 Motherboard (this is the pulse signal out of the A11 Pulse/Analog Modulation Generator).

Change the pulse period to 1 ms and the pulse width to 500 μ s.

- If the pulse is not present, perform the A11 Pulse/Analog Modulation Generator self-test, and follow the troubleshooting procedure.
4. If pulse modulation is working, perform the A8 Output self-test.
 - If the self-test passes, refer to [“Troubleshooting the RF Path” on page 106](#), and check the lowband (<3.2 GHz) path.
 - If the self-test fails, refer to the A8 Output test troubleshooting.

1208 Quadraplier

1. If the power supplies +15V, -15V, -3V, -5.2V, +6.5V, +3.5V, or -3V fail, refer to the table on [page 62](#), and check the supplies used by the A35 I/Q Modulator as they leave A26 MID connector.

If the signals are good at the A26 MID connector, replace the A36 Quadraplier.

2. If the TC902, TC956 or any of the drain currents fail (test indexes 6 through 24), replace the A36 Quadraplier.

3. If self-test 20-40 GHz Prelevel, index 25, fails:

- a. On the signal generator, set the following:

Center Frequency: 30 GHz

Power: -20 dBm

RF: On

- b. Remove the cable from J6 of the Quadraplier Bias Board and connect it to a DVM.

- c. The signal should measure approximately +5.2 Vdc.

1. If the signal is bad, troubleshoot the RF path.

2. If the signal is good, replace the A36 Quadraplier.

4. If self-test 20-40 GHz Prelevel, index 26, fails:

- a. On the signal generator, set the following:

Center Frequency: 45GHz

Power: -20 dBm

RF: On

- b. Remove the cable from J7 of the Quadraplier Bias Board and connect it to a DVM.

- c. The signal should measure approximately +5.4 Vdc.

1. If the signal is bad, troubleshoot the RF path.

2. If the signal is good, replace the A36 Quadraplier.

Self-Tests 12xx: A26 MID Self-Test Errors (E8267D)

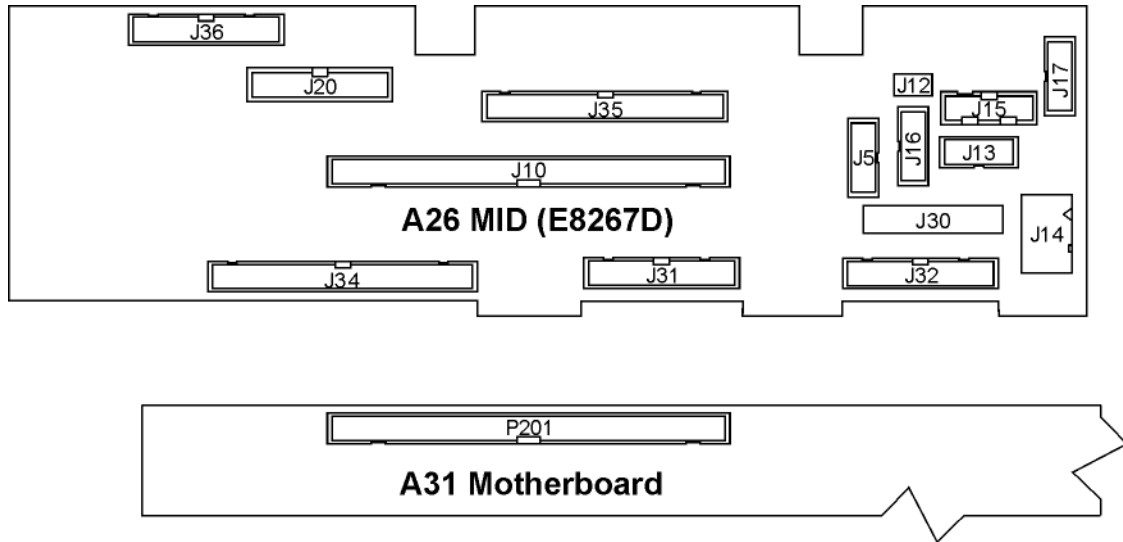

Before proceeding to the reported self-test error code, check the following voltages in. If any of these voltages are out of specification, troubleshoot the supply problem first.

Supply Voltage (Vdc)	E8267D Connector Pins	All Other Models Connector Pins	Minimum Value (Vdc)	Maximum Value (Vdc)	Origin
+32	P201-11	P201-1	+31.04	+32.96	Main Supply
+15	P201-12, 13, 14	P201-2, 3, 4	+14.55	+15.45	Main Supply
-15	P201-21, 22	P201-11, 12	-15.45	-14.55	Main Supply
+5.2	P201-7, 8, 9, 10, 23, 24, 25, 26, 27, 28	P201-13, 14, 15, 16, 17, 18	+5.04	+5.36	Main Supply
+10	P201-15, 16, 17, 18, 19, 20	P201-5, 6, 7, 8, 9, 10	+9.7	+10.3	Main Supply
+8	P201-39	P201-29	+7.5	+8.5	MID
-7	P201-40, 43, 56	N/A	-7.21	-6.79	Main Supply
-5.2	P201-41, 42	P201-31, 32	-5.30	-5.10	YIG Driver
+5.2 Digital high	P201-33	P201-23	+5.04	+5.36	Main Supply
+3.4 Digital Low	P201-34	P201-24	+3.3	+3.5	Main Supply

1200 Power Supply

1. Press **View Test Info** and highlight Self Test 1200. Press **View Details**.

2. From the displayed self-test results, determine which supply or supplies failed.
3. Refer to the following table; disconnect one microcircuit at a time and run self-test 1200.

Microcircuit (E8267D)	A26 MID Connector	+12V	+8V	+9V	+5.2V	-5.2V
A30 Modulation Filter	J31	✓	✓		✓	✓
A29 20 GHz Doubler	J32	✓	✓		✓	✓
A27 40 GHz Doubler	J36		✓		✓	✓
A35 3–20 GHz IQ Modulator	J34	✓	✓	✓	✓	✓
A37 Upconverter	J35		✓	✓	✓	✓

- If the test passes after disconnecting one or more microcircuits, replace the microcircuit.
- If self-test still fails after disconnecting all the microcircuits, replace the A26 MID.

1201 Mod Filter

1. Disconnect the cable between the A23 Lowband Coupler/Detector and the A30 Modulation Filter, and connect a spectrum analyzer to the cable.
2. Tune the source across the lowband frequencies (250 kHz to 3.2 GHz) and record the lowest power level.
3. Disconnect the cable coming from the A29 20 GHz Doubler, and connect the spectrum analyzer to this cable.
4. Tune the source across the A29 20 GHz Doubler band of frequencies (3.2 GHz to 20 GHz) and record the lowest power level.
5. Determine the expected levels using the tools described in **“Troubleshooting RF Power Levels” on page 106**, and compare them to the measured levels.
 - If the power level in both paths is good, replace the A30 Modulation Filter.
 - If the power level in **either** path is bad, troubleshoot that path.
 - If the power level in both paths is bad, check the signal levels out of the A28 YIG Oscillator.

1202 A29 20 GHz Doubler

1. Disconnect the cable between the A28 YIG Oscillator and the A29 20 GHz Doubler, and connect a spectrum analyzer to the cable.

2. Tune the source frequency across the A28 YIG Oscillator range (3.2 GHz to 10 GHz) and record the lowest power level.
3. Determine the expected levels using the tools described in [“Troubleshooting RF Power Levels” on page 106](#), and compare them to the measured levels.
 - If the power level is good, replace the A29 20 GHz Doubler.
 - If the power level is bad, replace the A28 YIG Oscillator.

1203 40 GHz Doubler

1. Disconnect the 13.3 to 18 GHz cable between the A29 20 GHz Doubler and the A27 40 GHz Doubler, and connect a spectrum analyzer to the cable.
2. Determine the expected levels using the tools described in [“Troubleshooting RF Power Levels” on page 106](#), and compare them to the measured levels.
 - If both power level is good, replace the A27 40 GHz Doubler.

1204 RF Path

This test checks for a dc voltage on the A10 ALC from the A23 Lowband Coupler/Detector and A24 Highband Coupler and A25 Highband Detector.

1. Connect a spectrum analyzer to the RF output of the signal generator.
2. Turn the RF power on and verify the presence of an RF signal on the output.
 - If no RF signal is present, troubleshoot the RF path problem (see [“Troubleshooting the RF Path” on page 106](#)).
3. If an RF signal is present on the RF output, set the signal generator to 4 GHz and 0 dBm.
4. Measure the dc voltage on the cable going to J3 of the A10 ALC. The signal should be approximately -0.3 Vdc.
 - If the signal at J3 is good, go to step 6.
5. If no dc signal is present on the cable to J3, check the output at the highband detector.
 - If the signal is good at the detector, replace the cable.
 - If no signal is present at the output of the highband detector, replace the highband detector.
6. If the signal at J3 is good, set the signal generator’s frequency to <1 GHz, the power to 0 dBm, and measure the dc voltage on the cable going to J5 on the A10 ALC.

- If the dc voltage is approximately -2.2 Vdc, replace the A10 ALC.
7. If other dc voltages are present, check for dc voltage on the output of the lowband detector.
 - If a dc voltage is present, replace the cable.
 - If no dc voltage is present, replace the lowband detector.

1205 LB Pulse Mod

Lowband Pulse On

1. Disconnect the cable from J5 of the A10 ALC, and connect the cable to a DVM (this is the lowband detector output).
2. On the signal generator, set the following:
 - Center Frequency: 3 GHz
 - Power: +20 dBm
 - Pulse Modulation: On
 - Period: 40s
 - Pulse Width: 10 ns
 - RF: On
3. The voltage measured by the DVM should be approximately 0V. If it is not, use an oscilloscope to view P131-6 of the A31 Motherboard (this is the pulse signal out of the A11 Pulse/Analog Modulation Generator).

Change the pulse period to 1 ms and the pulse width to 500 μ s.

- If the pulse is not present, perform the A11 Pulse/Analog Modulation Generator self-test, and follow the troubleshooting procedure.
4. If pulse modulation is working, perform the A8 Output self-test.
 - If the self-test passes, refer to [“Troubleshooting the RF Path” on page 106](#), and check the lowband path.
 - If the self-test fails, refer to the A8 Output test troubleshooting.

Lowband Pulse Off

1. Disconnect the cable from J5 of the A10 ALC, and connect the cable to a DVM (this is the lowband detector output).
2. On the signal generator, set the following:
 - Center Frequency: 3 GHz
 - Power: +20 dBm
 - Pulse Modulation: On
 - Period: 40s
 - Pulse Width: 39.9s
 - RF: On

3. The voltage measured by the DVM should be approximately -1.8 V. If it is not, use an oscilloscope to view P131-6 of the A31 Motherboard (this is the pulse signal out of the A11 Pulse/Analog Modulation Generator).

Change the pulse period to 1 ms and the pulse width to 500 μ s.

- If the pulse is not present, perform the A11 Pulse/Analog Modulation Generator self-test, and follow the troubleshooting procedure.
4. If pulse modulation is working, perform the A8 Output self-test.
 - If the self-test passes, refer to “[Troubleshooting the RF Path](#)” on [page 106](#), and check the lowband (<3.2 GHz) path.
 - If the self-test fails, refer to the A8 Output test troubleshooting.

1206 20 GHz IQ Modulator

1. If the power supplies +8V AF, +2.5V AF, +9V AFSW, +12V AFSW, +15V VLIMF, or -15 VSWBIAS fail, refer to the table [page 67](#), and check the supplies used by the A35 I/Q Modulator as they leave the A26 MID connector.
 - If the signals are good at the A26 MID connector, replace the A35 I/Q Modulator.
2. If the VD724 Doubler, test index 6, fails, replace the A35 I/Q Modulator.
3. If self-test TC672RF indexes 8, 9, 11, or 12 fail:
 - a. Remove the cable from J2 of the A29 20 GHz Doubler.
 - b. While measuring the signal at J2 with a spectrum analyzer, run self-test 1206. You should see a +20 dBm signal at 5 GHz.
 - If the signal is bad, troubleshoot the RF path.
 - If the signal is good and TC672RF indexes 8, 11, or 12 have failed, replace the A35 I/Q Modulator.
 - If the signal is good and TC672RF index 9 has failed, you must also check the I/Q signals from the A13 I/Q Multiplexer:
 1. Remove the cable from J6 (I) of the A35 I/Q Modulator, and connect it to an oscilloscope.
 2. Execute a single 1206 self-test. The signal on the oscilloscope should pulse to approximately -0.5 Vdc for approximately 500 ms.
 - If the signal is bad, refer to the A13 I/Q Multiplexer troubleshooting.
 3. If the signal is good, reconnect the cable to J6, remove the cable to J7 (Q), and connect this cable to the oscilloscope.

4. Execute a single 1206 self-test. The signal on the oscilloscope should pulse to approximately 18 millivolts for approximately 500 ms.

- If the signal is bad, refer to the A13 I/Q Multiplexer troubleshooting.
- If both the I and Q signals are good, replace the A35 I/Q Modulator.

4. If self-test Quad Loop Integrator fails, replace the A35 I/Q Modulator.

1207 Upconverter

1. If the power supplies +6.5V or +5.2V fail, refer to the table [page 67](#), and check the supplies used by the A37 Upconverter as they leave the A26 MID connector.

- If the signals are good at the A26 MID connector, replace the A37 Upconverter.

2. If any of the drain currents fail (test indexes 3 through 18), replace the A37 Upconverter.

3. If self-tests ALC (indexes 18 through 32) Vdet (indexes 24 through 26) fail:

a. On the signal generator, set the following:

Center Frequency: Value at which ACL or Vdet self-test failed (e.g. 20.01 GHz, 28.5 GHz, etc.)

Power: +20 dBm

RF: On

b. Disconnect A35–J24 and connect a spectrum analyzer to the A35 I/Q Modulator. This is the IF signal to the A37 Upconverter.

c. For RF signals >20 GHz to 28.5 GHz, the IF signal is mixed with the LO to produce the downconverted RF signal. The IF signal will range in frequency from 6.667 GHz to 9.50 GHz with an amplitude of >5 dBm.

- If the signal is bad, troubleshoot the A35 RF path.
- If the signal is good, reconnect A35–J24.

d. On the A37 Upconverter, disconnect J5 and connect a spectrum analyzer to the cable coming from the A27 40 GHz Doubler. This is the LO signal to the A37 Upconverter.

e. For RF signals >20 GHz to 28.5 GHz, the IF signal is mixed with the LO to produce the downconverted RF signal. The LO signal will range in frequency from 26.667 GHz to 38 GHz and will be four times the IF frequency. The amplitude of the LO signal should be >5 dBm.

- If the signal is bad, troubleshoot the A35 RF path.

- If the signal is good, reconnect A37–J5 and replace the A37 Upconverter.
- f. For RF signals >28.5 GHz, the IF signal frequency is mixed with the LO to produce the upconverted RF signal. The IF signal will range in frequency from 5.73 GHz to 8.82 GHz. The LO signal will range in frequency from 22.8 GHz to 38.2 GHz and will be four times the IF frequency. Repeat steps a through e, but with an RF signal >28.5 GHz.

Self-Tests 13xx: A11 Analog/Pulse Modulation Generator Self-Test Errors

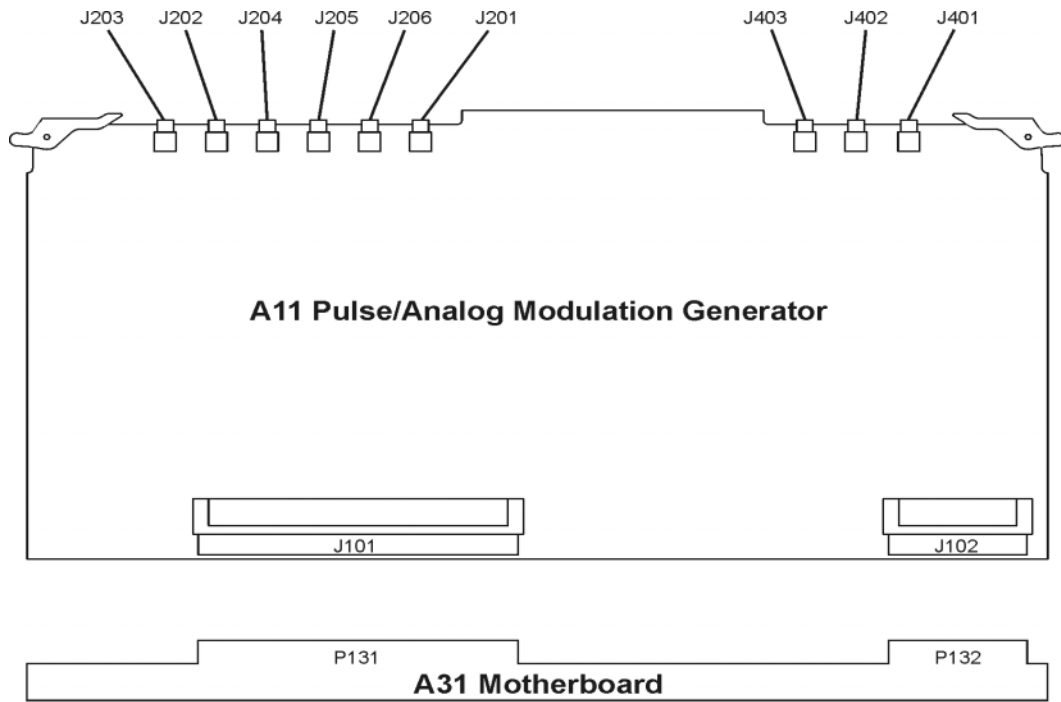

Before proceeding to the reported self-test error code, check the following voltages. If any of these voltages are out of specification troubleshoot the supply problem first.

Supply Voltage (Vdc)	Connector Pins	Minimum Value (Vdc)	Maximum Value (Vdc)	Origin
+15	P132-28	+14.55	+15.45	Main Supply
-15	P132-3	-14.55	-15.45	Main Supply
+5.2	P132-2, 27	+5.04	+5.37	Main Supply
-5.2	P132-1, 26	-5.3	-5.1	YIG Driver

Supply Voltage (Vdc)	Connector Pins	Minimum Value (Vdc)	Maximum Value (Vdc)	Origin
+5.2 Digital high	P131-64, 65, 129, 130	+5.04	+5.36	Main Supply
+3.4 Digital Low	P131-60, 61, 62, 63, 125, 126, 127, 128	+3.29	+3.5	Main Supply

1300 Power Supply

- Replace the A11 Reference.

1301 Internal Pulse Generator Clock

1. Using an oscilloscope, measure P131-91 for a 10 MHz signal at 3.5 V_{pp}.
 - If the signal is good, replace the A11 Pulse/Analog Modulation Generator.
2. If the signal is bad, check P41-7.
 - If the signal is good on P41-7, replace the A31 Motherboard.
 - If the signal is bad on P41-7, replace the A7 Reference.

1302 Output

- Replace A11 Pulse/Analog Modulation Generator.

1303 Voltage Ref DAC

- Replace A11 Pulse/Analog Modulation Generator.

1304 20 GHz Pulse

- Replace A11 Pulse/Analog Modulation Generator.

1305 Not Used

1306 Standard 3 GHz Pulse

- Replace A11 Pulse/Analog Modulation Generator.

1307 High Performance 3 GHz Pulse

- Replace A11 Pulse/Analog Modulation Generator.

1308 Numeric Synthesizer

- Replace A11 Pulse/Analog Modulation Generator.

1309 Function Generator Channel 1

- Replace A11 Pulse/Analog Modulation Generator.

1310 Function Generator Channel 2

- Replace A11 Pulse/Analog Modulation Generator.

1311 Frequency Modulator

- Replace A11 Pulse/Analog Modulation Generator.

1312 Low Frequency Out

- Replace A11 Pulse/Analog Modulation Generator.

1313 Amplitude Modulation

- Replace A11 Pulse/Analog Modulation Generator.

1314 External 1

- Replace A11 Pulse/Analog Modulation Generator.

1315 External 2

- Replace A11 Pulse/Analog Modulation Generator.

1316 AM Path Loss

- Replace A11 Pulse/Analog Modulation Generator.

Self-Tests 16xx for the A14 Baseband Generator (Option 601/602)

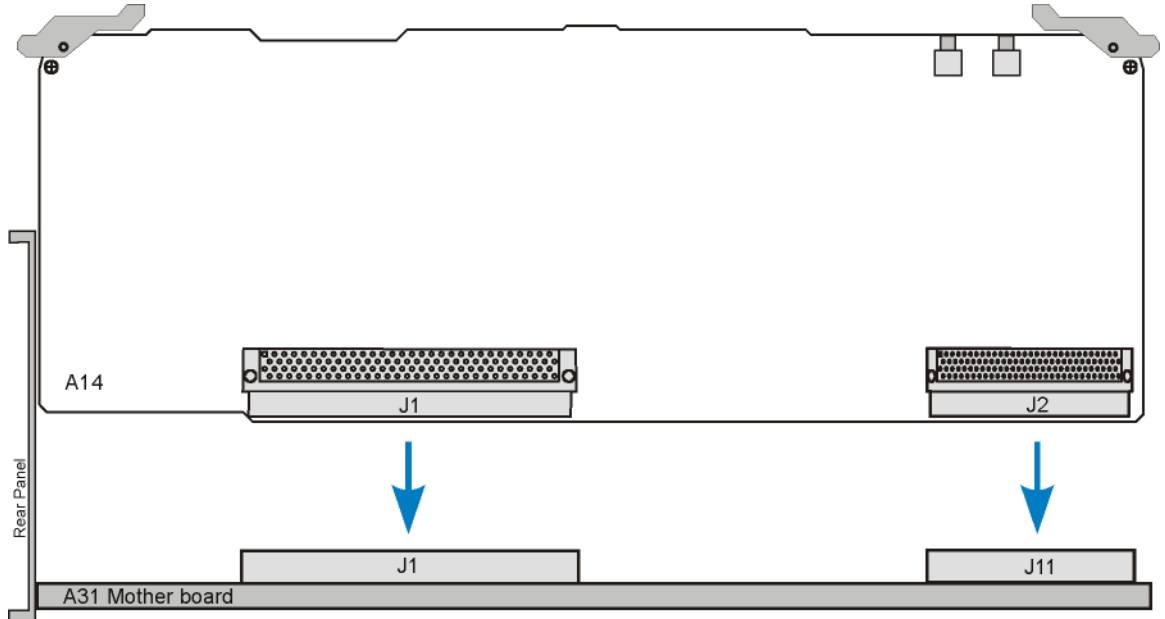

Power Supply Voltage (Vdc)	A31 Motherboard Connector Pins	Minimum (Vdc)	Maximum (Vdc)	Origin
+32	P162 - 4	+31.04	+32.96	Main Supply
+15	P162 - 28	+14.55	+15.45	Main Supply
-15	P162 - 3	-15.45	-14.55	Main Supply
-5.2 V2	P162 - 1, 26	-5.36	-5.04	A31 Motherboard
+5.2	P162 - 5, 27	+5.04	+5.36	Main Supply
+5.2 D	P161 - 64, 65, 129, 130	+5.04	+5.36	Main Supply
+3.4 VD	P161 - 60, 61, 62, 63, 125, 126, 127, 128	+3.30	+3.50	Main Supply
+2.6 VD	P161 - 57, 58, 59, 123, 124	+2.52	+2.68	Main Supply
+1.95 VD	P161 - 52, 118	+1.89	+2.01	A31 Motherboard
+1.8 VD	P161 - 55, 56, 120, 121, 122	+1.75	+1.85	A31 Motherboard

1600 Host <-> BBG Comm

- If the +3.4 VD, +2.6 VD, and +1.9 VD supply voltages are good on the A31 Motherboard, replace the A14 Baseband Generator.
- If the +3.4 VD or +2.6 VD supply voltages are bad on the A31 Motherboard, check the origin of the supply.
 - If the supply voltage is good at the origin, replace the A31 Motherboard.
 - If the supply voltage is bad at the origin, troubleshoot the A19 Power Supply.
- If the +1.9 VD supply voltage is bad on the A31 Motherboard, check the +3.4 VD supply at the A19 Power Supply.
 - If the +3.4 VD supply is good at the A19 Power Supply, replace the A31 Motherboard.
 - If the +3.4 VD supply is bad at the A19 Power Supply, troubleshoot A19 Power supply.

1601 Apps 1 <-> Apps 2 Comm

- If the +1.8 VD supply voltage is good on the A31 Motherboard, replace the A14 Baseband Generator
- If the +1.8 VD supply voltage is bad on the A31 Motherboard, check the +2.6 VD supply at the A19 Power Supply.
 - If the +2.6 VD supply is good at the A19 Power Supply, then replace the A31 Motherboard.
 - If the +2.6 VD supply is bad at the A19 Power Supply, then troubleshoot the A19 Power supply.

1602 Apps 1 <-> SH4 Comm

- Replace the A14 Baseband Generator

1603 Apps 2 <-> SH4 Comm

- Replace the A14 Baseband Generator

1604 FLiegen <-> Apps 2 Comm

- Replace the A14 Baseband Generator

1605 SRAM Test

- Replace the A14 Baseband Generator

1606 SDRAM Test

- Replace the A14 Baseband Generator

1607 Paren <-> SH4 Comm

- Replace the A14 Baseband Generator

1608 VCO Tune Test

- If the +32 V, ± 15 V, -5.2 V₂, and + 5.2V supply voltages are good on the motherboard, use an oscilloscope to check the 10 MHz signal on the A31 Motherboard at P161 pins 26 and 91. The signal should have a period of 100 ns with an amplitude greater than 0.4 V_{pp}.
 - If the 10 MHz signal is good, replace the A14 Baseband Generator.
 - If the 10 MHz signal is bad, check it at the A7 Reference.
 - If the 10 MHz signal is bad at the A7 Reference, refer to A7 Reference troubleshooting.
 - If the 10 MHz signal is good at the A7 Reference, replace the A31 Motherboard.
- If the +32 V, ± 15 V, and +5.2 V supply voltages are bad on the motherboard, check the origin of the supply.
 - If the supply voltage is good at the origin, replace the A31 Motherboard.
 - If the supply voltage is bad at the origin, troubleshoot the A19 Power Supply.
- If the -5.2 V₂ supply voltage is bad on the motherboard, check the -7 V supply voltage at the A19 Power Supply.
 - If the -7 V supply voltage is good at the A19 Power Supply, replace the A31 Motherboard.
 - If the -7 V supply voltage is bad at the A19 Power Supply, troubleshoot the A19 Power supply.

1609 IQ DAC Output

- Replace the A14 Baseband Generator

1610 PLL Test

- Replace the A14 Baseband Generator

Self-Tests 22xx: A8 Output Self-Test Errors

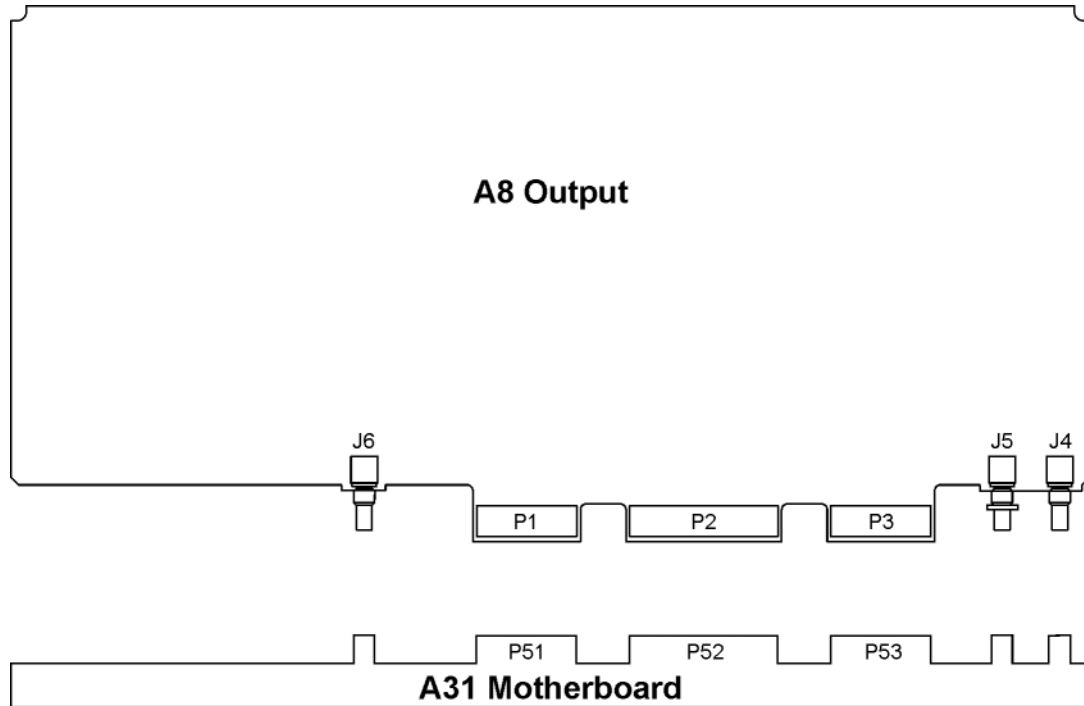

Before proceeding to the reported self-test error code, check the following voltages. If any voltages are out of specification troubleshoot the supply problem first.

Supply Voltage (Vdc)	Connector Pins	Minimum Value (Vdc)	Maximum Value (Vdc)	Origin
+15	P52-6, 21	+14.55	+15.45	Main Supply
-15	P52-2, 17	-15.45	-14.55	Main Supply
+5.2	P52-14, 29	+5.04	+5.36	Main Supply
+9	P52-5, 20	+8.82	+9.18	YIG Driver
-6	P52-3, 18	-6.12	-5.88	YIG Driver

2200 Ground and PTAT Test

- Replace A8 Output.

2201 Prelevel Loop Test

NOTE

If the A8 Output board has been replaced recently and self test 2201 is failing, run the ALC Mod Cal adjustment before replacing the A8 Output board. See [Chapter 4, “Post-Repair Procedures.”](#)

1. With the signal generator powered on, carefully remove the A8 Output.
2. Set the signal generator to 3 GHz CW.
3. Connect a spectrum analyzer to the A6 Frac-N RF output at J4 of the A8 Output. The signal at J4 should be at 3 GHz and ≥ 0 dBm.
 - If the signal is not present or at the correct level, replace the Frac-N.
 - If the signal is present, replace the A8 Output.

WARNING

Do not re-install the A8 Output with the signal generator powered on. This can cause serious damage to the signal generator.

2202 Switching Filter Test

- Replace the A8 Output.

2203 ALC Mod System Test

- Replace the A8 Output.

2204 Pulse Mod System Test

- Replace the A8 Output.

2205 RF Path Test

- Replace the A8 Output.

2206 Het Band Test

- Replace the A8 Output.

Self-Tests 24xx: A38 Lowband Filter Self-Test Errors

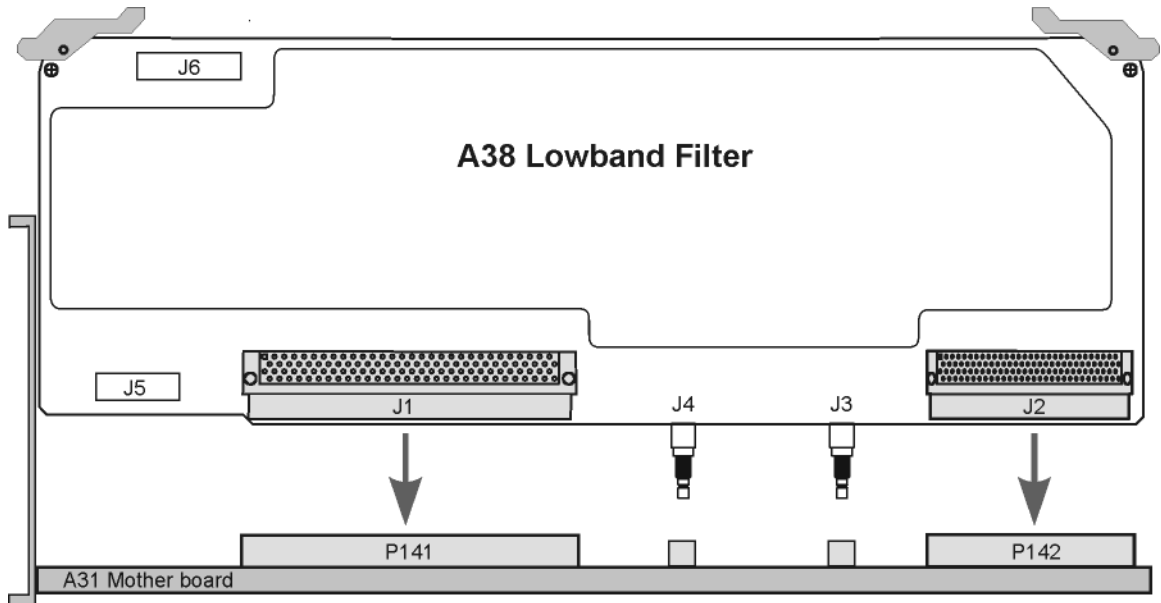

Before proceeding to the reported self-test error code, check the following voltages. If any voltages are out of specification troubleshoot the supply problem first.

Supply Voltage (Vdc)	Connector Pins	Minimum Value (Vdc)	Maximum Value (Vdc)	Origin
+32	P142-4	+31.04	+32.96	Main Supply
+15	P142-28	+14.55	+15.45	Main Supply
-15	P142-3	-15.45	-14.55	Main Supply
+5.2	P142-2, 27	+5.04	+5.36	Main Supply
-5.2	P142-1, 26	-5.30	-5.10	YIG Driver
+5.2 Digital High	P141-64, 65, 129, 130	+5.04	+5.36	Main Supply
+3.4 Digital Low	P141-60, 61, 62, 63, 125, 126, 127, 128	+3.3	+3.5	Main Supply
+2.6	P141-57, 58, 59, 123, 124	+2.52	+2.68	Main Supply
+1.8	P141-55, 56, 120, 121	-1.75	-1.85	Motherboard

2400 Power Supply Test

- If the +15V and –15V power supplies are good in the above table, replace the A38 Lowband Filter.

2401 RF Path Test

1. Remove the A38 Lowband Filter and insert a semi-rigid extender cable into J3.
2. Connect the extender cable to a spectrum analyzer.
3. Tune the spectrum analyzer and signal generator to 2 GHz. Turn on the signal generator's RF.
4. You should see a high power signal (>+20 dBm) at 2 GHz on the spectrum analyzer.
 - If the signal is good, replace the A38 Lowband Filter.
 - If the signal is troubleshoot the RF path.

2402 Lowband Amp/Filter Power Supply

- Replace the A38 Lowband Filter.

2403 RF Path

- Replace the A38 Lowband Filter.

Self-Tests 25xx: A43 Amp Filter Self-Test Errors

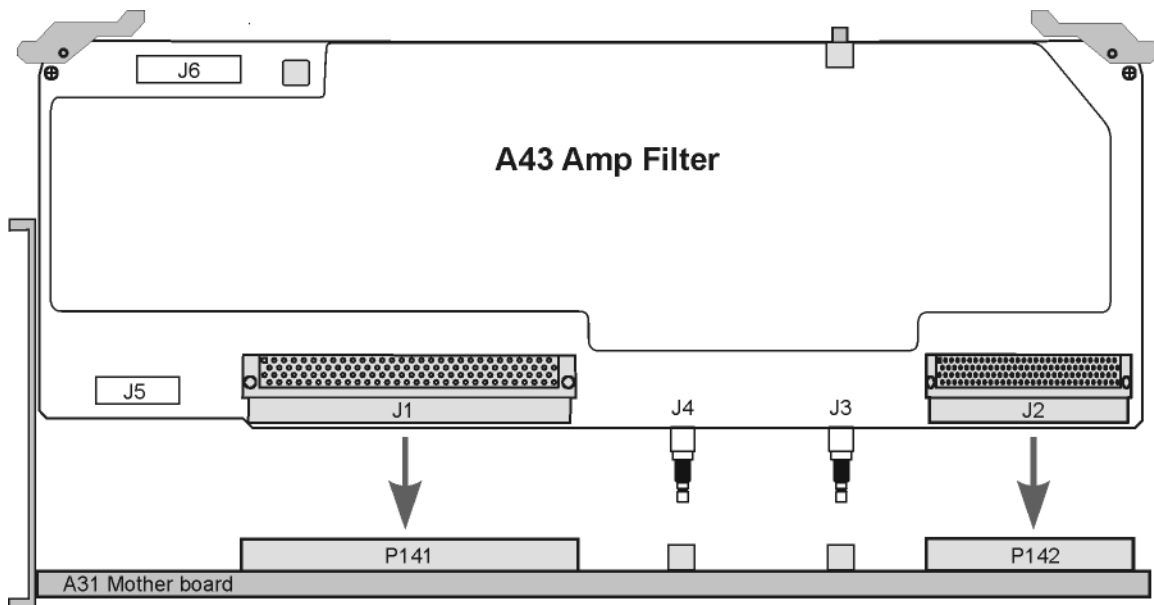

Before proceeding to the reported self-test error code, check the following voltages. If any voltages are out of specification troubleshoot the supply problem first.

Supply Voltage (Vdc)	Connector Pins	Minimum Value (Vdc)	Maximum Value (Vdc)	Origin
+15	P142-28	+14.55	+15.45	Main Supply
-15	P142-3	-15.45	-14.55	Main Supply
+5.2	P142-2, 27	+5.04	+5.36	Main Supply
-5.2	P142-1, 26	-5.30	-5.10	YIG Driver
+5.2 Digital High	P141-64, 65, 129, 130	+5.04	+5.36	Main Supply
+3.4 Digital Low	P141-60, 61, 62, 63, 125, 126, 127, 128	+3.3	+3.5	Main Supply
+10	P142, 10, 11, 36	+9.7	+10.3	Main Supply

2500 Power Supply Test

- If the power supplies, in the table above, are good, replace the A43 Amp Filter.

2501 RF Amp Test

- Replace the A43 Amp Filter.

2502 Filter Path Test

- Replace the A43 Amp Filter.

2503 Pulse Modulator Test

- Replace the A43 Amp Filter.

2504 Step Attenuator Test

- Replace the A43 Amp Filter.

2505 Divider On/Off Test

- Replace the A43 Amp Filter.

Self-Tests 26xx: A8 Output Self-Test Errors

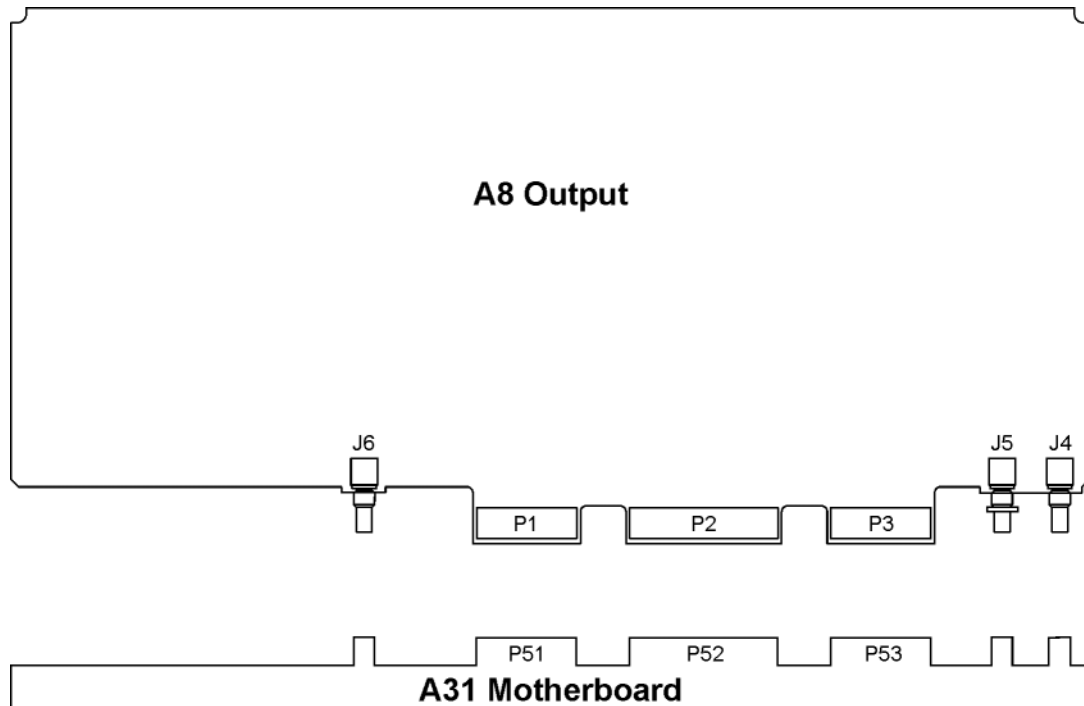

Before proceeding to the reported self-test error code, check the following voltages. If any voltages are out of specification troubleshoot the supply problem first.

Supply Voltage (Vdc)	Connector Pins	Minimum Value (Vdc)	Maximum Value (Vdc)	Origin
+15	P52-6, 21	+14.55	+15.45	Main Supply
-15	P52-2, 17	-15.45	-14.55	Main Supply
+5.2	P52-14, 29	+5.04	+5.36	Main Supply
+9	P52-5, 20	+8.82	+9.18	YIG Driver
-6	P52-3, 18	-6.12	-5.88	YIG Driver

2600 Power Supply Test

- Replace A8 Output.

2601 Prelevel Loop Test

NOTE

If the A8 Output board has been replaced recently and self test 2201 is failing, run the ALC Mod Cal adjustment before replacing the A8 Output board. See [Chapter 4, “Post-Repair Procedures.”](#)

1. With the signal generator powered on, carefully remove the A8 Output.
2. Set the signal generator to 3 GHz CW.
3. Connect a spectrum analyzer to the A6 Frac-N RF output at J4 of the A8 Output. The signal at J4 should be at 3 GHz and ≥ 0 dBm.
 - If the signal is not present or at the correct level, replace the Frac-N.
 - If the signal is present, replace the A8 Output.

WARNING

Do not re-install the A8 Output with the signal generator powered on. This can cause serious damage to the signal generator.

2602 ALC Modulator Test

- Replace the A8 Output.

2603 Pulse Modulator Test

- Replace the A8 Output.

2604 Clamp Detector Test

- Replace the A8 Output.

2605 Bias Switch Test

- Replace the A8 Output.

2606 Switched Filters Test

- Replace the A8 Output.

2607 DAC Functionality Test

- Replace the A8 Output.

2608 Het Band Test

- Replace the A8 Output.

Self-Tests 27xx: A46 Offset Loop Self-Test Errors (Option UNY)

2700 Frac-N Signal Test

- Replace the A46.

2701 Offset VCO Test

- Replace the A46.

2702 Fstep OSL Test

- Replace the A46.

2703 Offset Loop Detector Test

- Replace the A46.

2704 Fcomb at YOL Test

- Replace the A46.

2705 YO Loop Detector Test

- Replace the A46.

Self-Tests 28xx: A8 Vector Output Self-Test Errors

2800 Power Supply Test

- Replace the A8.

2801 Prelevel Loop Test

- Replace the A8.

2802 ALC Mod System Test

- Replace the A8.

2803 Pulse Mod System Test

- Replace the A8.

2804 Clamp Detector Test

- Replace the A8.

2805 Bias Switch Test

- Replace the A8.

2806 Switch Filters Test

- Replace the A8.

2807 DAC Functionality Test

- Replace the A8.

Troubleshooting Unlocks

The phase lock loop refers to part of the frequency generating circuit used to maintain the phase relationship between the frequency generation loop and a reference frequency. By maintaining the phase relationship, the frequency accuracy of the signal generator is guaranteed.

To maintain frequency accuracy the phase lock loop compares the phase of a signal from the reference assembly to the phase of the frequency loop signal. If the signals are slightly out of phase, the phase comparator circuit adjusts the frequency loop signal until the two signals are in phase. If the phase comparator circuit cannot adjust the phase of the frequency loop signal to agree with the reference signal, the phase comparator rails and generates an unlocked message. The unlock message is immediately displayed on the front panel display.

There are four phase lock circuits in the frequency generation loop that can generate error messages. These phase lock loops are located on the A6 Frac–N, A5 Sampler, and A7 Reference. There is also one other phase lock loop on the A11 Pulse/Analog Modulation Generator that can generate an error message when the signal generator is in phase modulation mode.

CAUTION

To avoid damage to the signal generator, turn it off and disconnect it from the power source before installing or reinstalling any assembly.

508 A6 Frac–N Loop Unlock

This error can indicate a failure in other than the A6 Frac–N Loop board. To determine which assembly is defective, check whether the error occurs in both the CW and sweep modes, or in just the sweep mode.

- Occurs in both the CW and sweep modes:

Check P33–15 on the A31 Motherboard for the 10 MHz sync. approximately $2 V_{pp}$.

- If the signal is present replace the A6 Frac–N.
 - If the signal is not present, troubleshoot back to the A7 Reference.
- Occurs in only the sweep mode:
 1. Start narrowing the sweep frequency range and increasing the sweep time.
 2. If making the sweep adjustments resolves the error, replace the A28 YIG Oscillator.
 3. If the A28 YIG Oscillator does *not* resolve the error, replace the A9 YIG Driver.

512 A7 Reference Unlock

The instrument's reference is unlocked. Use the following list to troubleshoot the problem.

NOTE

The error message remains until it is cleared. Ensure that you clear the error message prior to each check to properly determine whether the error still persists.

- If an external reference is connected:
 1. Measure the external reference signal frequency.
 2. Measure the external reference signal power level.
 3. Compare the results from **Step 1** and **Step 2** against the specifications found in the E82x7D PSG data sheet.
 4. Check the connection to the PSG along with the connectors.
 5. Connect a different external reference source.
 6. If the error persists, replace the A7 reference board:
- If the error occurs when you initially connect or disconnect the external reference:
 1. Clear the error queue: press **Utility > Error Info > Clear Error Queue(s)**.
 2. With no changes to the external reference connection, check to ensure that the error does not reappear.
 3. If the error reappears, replace the A7 reference board.
- If none of the above apply, replace the A7 reference board.

513 1 GHz Out of Lock

A 513 1 GHz Out of Lock message indicates a failure on the A7 Reference.

- Replace the A7 Reference.

514 Reference Oven Cold

The Reference Oven Cold Error message indicated the reference has not been connected to electrical power for 30 minutes. This message appears when the signal generator is unplugged or the reference assembly is removed. The message is controlled by a timer and should turn off after 30 minutes. This is not a failure unless the message does not go off after 30 minutes. If it continues to be displayed after 30 minutes, replace the A7 Reference.

515 10 MHz Signal Bad

A 515 10 MHz Signal Bad message indicates a problem on the A7 Reference.

A7 Reference (Standard)

- Replace the A7 Reference.

A7 Reference (Option UNR/UNX)

1. Check the 10 MHz signal into the A7 Reference from the 10 MHz standard. The signal should be 10 MHz 1.8 V_{pp} into 1 MΩ.
2. If the 10 MHz signal is bad, replace the A32 10 MHz Crystal Oscillator.
3. If the signal is good, replace the A7 Reference.

520 Sampler Unlocked

A 520 Sampler unlock message indicates a failure of the A5 Sampler VCO loop.

1. Run self-test. If self-test fails, troubleshoot the problem reported.
2. Power-up the signal generator. Remove the A5 Sampler. Probe the mmx connection center pin on the right side of the A31 Motherboard in the A5 Sampler slot. There should be a 1 GHz signal >0 dBm.
3. If the 1 GHz signal is present, replace the A5 Sampler.
4. If the 1 GHz signal is not present, replace the A7 Reference.

521 YO Loop Unlocked

A 521 YO Loop unlocked message indicates a failure of the A5 Sampler's YO Phase detector circuit.

Execute the YIG pretune calibration: Press **Utility** > **Instrument Adjustments** > **Service Adjustments** > **YIG PreTune Calibration** > **Execute Cal.**

- If this resolves the error, the repair is complete.
- If this does not resolve the error, perform the following steps:
 1. Run self tests.
 - a. If the self tests pass, continue to step 2.
 - b. If the self tests fail, troubleshoot the reported failure.
 2. Set the signal generator to 5 GHz.
 3. While the signal generator is on, remove the A5 Sampler.

4. Probe the mmx connectors on the A31 Motherboard:

Connector	Signal
right mmx connector	1 GHz >0 dBm from A7 Reference
center mmx connector	5 GHz from A29 20 GHz Doubler -6 dBm
left mmx connector	approximately 850 MHz >-6 dBm from A6 Frac-N

- If all signals are present:
 1. Turn off the signal generator and disconnect the power cord.
 2. Replace the A5 Sampler.
- If a signal is not present for a connector listed above:
 1. Troubleshoot back to that connector's assembly.
 2. If the signal is not present at the assembly:
 - a. Turn off the signal generator and disconnect the power cord.
 - b. Replace the assembly.
 3. Reinstall the A5 Sampler.
 4. Replace W11.

625 Internal Pulse Generator Unlock

A 625 internal pulse generator unlocked message indicates a failure on the A11 Pulse/Analog Modulation Generator.

- Replace the A11 Pulse/Analog Modulation Generator.

626 Internal Mod Source Unlock

A 626 Internal Mod Source Unlock error message indicates a problem with the digital 10 MHz signal to the A11 Pulse/Analog Modulation Generator. This error message is turned on if the signal generator is in phase modulation mode and there is a problem with the 10 MHz digital signal to the in phase clock.

1. Set the signal generator to phase modulation mode.
2. Measure pin P131-91. The waveform is not a sine wave, but more like a distorted pulse waveform $>2 V_{pp}$.
3. If the waveform is present, replace the A11 Pulse/Analog Modulation Generator.
4. If the signal is not present, replace the A7 Reference.

Troubleshooting Unlevels

A leveled output power is obtained by comparing a detected voltage with a reference voltage. The reference voltage is generated using DACs on the A10 ALC and the detected voltage is generated by coupling off a portion of the RF output signal and converting it to dc using detector diodes. When the reference and detected levels are the same the integrated output level remains constant. When the detected and reference levels are not the same, the integrator output ramps either up or down to increase or decrease the detected level. If the integrator can not get the detected voltage and the reference voltage to match, an unlevelled annunciator is displayed.

The Automatic Leveling Circuit (ALC) uses two detectors and two modulator diodes. The A23 Lowband Coupler/Detector is used for frequencies 2 GHz and below. The A25 Highband Coupler/Detector is used for all frequencies above 2 GHz. The modulator in the A23 Lowband Coupler/Detector is used to control the RF amplitude for frequencies 3.2 GHz and below. The modulator in the A30 Modulation Filter is used to control the amplitude for frequencies above 3.2 GHz.

The RF path must provide a minimum power level to the ALC loop for the ALC loop to work properly. The minimum power required is slightly higher than the maximum leveled power. The first step to troubleshooting a leveling problem is to verify the RF path power level.

Troubleshoot and correct any unlock problems before troubleshooting unlevelled problems.

If the unlevelled annunciator is on:

- 1. Verify the signal generator's amplitude is not set higher than the maximum level specified on the data sheet. Verify that the signal generator's RF output is terminated into 50 ohms. If the unlevelled indication turns off after resetting the amplitude or terminating the RF output into 50 ohms, the signal generator is operating correctly. If the unlevelled indicator remains on, proceed to step 2.**
- 2. Using a spectrum analyzer check the RF signal level at the RF output connector.**

a. Signal generator and spectrum analyzer setup:

Signal Generator:

- Turn ALC Off
- Set Amplitude to 30 dBm
- Turn Modulation Off
- Turn RF On
- Set Sweep to Frequency
- Set Sweep Type to Step (if Option 007 is installed, you can use ramp sweep)
- Set Start Frequency to 250 kHz

- Set Stop Frequency to 3.2 GHz
- Set Number of Points to 500 (skip this step if using ramp sweep)

Spectrum Analyzer:

- Set Start Frequency to 225 kHz
- Set Stop Frequency to 3.25 GHz
- Set Reference Level to +30 dBm
- Set Display to Max Hold

- b. Connect the RF output of the signal generator to the spectrum analyzer. Measure and record the minimum power level.
- c. Set the signal generator and spectrum analyzer start/stop frequencies to the next start/stop frequencies in [Table 1-14](#). Repeat step b above.

Table 1-14

Signal Generator		Spectrum Analyzer	
Start	Stop	Start	Stop
3.2 GHz	20 GHz	3.15 GHz	20 GHz
20 GHz	Max. Freq.	20 GHz	Max. Freq.

- d. If any of the frequency ranges do not produce power levels \geq the maximum leveled power shown in the tables below, set the signal generator to the frequency with the lowest power level and measure the power with a power meter. If the power level is low, troubleshoot the RF path before proceeding.

Table 1-15 E8257D Maximum Leveled Power (dBm)^a

Frequency	20 GHz Models				40 GHz Models				50 & 67 GHz Models			
	Std.	1EA/ 1EU	1E1	1E1+ 1EA/ 1EU	Std.	1EA/ 1EU	1E1	1E1+ 1EA/ 1EU	Std.	1EA/ 1EU	1E1	1E1+ 1EA/ 1EU
250 kHz to 3.2 GHz	+13	+16	+11	+15	+9	+15	+7	+14	+5	+14	+3	+13
250 kHz to 3.2 GHz w/UNW	+11	+11	+10	+10	+9	+10	+7	+9	+5	+9	+3	+8
250 kHz to 3.2 GHz w/1EH ^b	+13	+13	+11	+12	+9	+12	+7	+11	+5	+11	+3	+10
250 kHz to 3.2 GHz w/UNW + 1EH ^b	+10	+10	+9	+9	+9	+9	+7	+8	+5	+8	+3	+7

Table 1-15 E8257D Maximum Levelled Power (dBm)^a

Frequency	20 GHz Models				40 GHz Models				50 & 67 GHz Models			
	Std.	1EA/ 1EU	1E1	1E1+ 1EA/ 1EU	Std.	1EA/ 1EU	1E1	1E1+ 1EA/ 1EU	Std.	1EA/ 1EU	1E1	1E1+ 1EA/ 1EU
>3.2 GHz to 20 GHz	+13	+20	+11	+18	+9	+18	+7	+16	+5	+14	+3	+13
>20 GHz to 30 GHz					+9	+14	+7	+12	+5	+11	+3	+9
>30 GHz to 40 GHz					+9	+14	+7	+12				
>30 GHz to 65 GHz									+5	+11	+3	+9
>65 GHz to 67 GHz									+5	+10	+3	+8
>67 GHz to 70 GHz									+5	+8	+3	+6

- a. always check data sheet for updates to specifications
- b. with filters switched out

Table 1-16 E8267D Maximum Levelled Power (dBm)^a

Frequency	20 GHz Models	32 & 44 GHz Models
250 kHz to 3.2 GHz	+13	+12
250 kHz to 3.2 GHz w/UNW	+9	+8
250 kHz to 3.2 GHz w/1EH ^b	+10	+9
250 kHz to 3.2 GHz w/UNW + 1EH ^b	+7	+6
>3.2 GHz to 20 GHz	+18	+14
>20 GHz to 31.8 GHz		+14
>31.8 GHz to 40 GHz		+12
>40 GHz to 44 GHz		+10

- a. Always check data sheet for updates to specifications
- b. With filters switched out

Table 1-17 E8663D Maximum Levelled Power (dBm)^a

Frequency	All Models			
	Std.	1EU	1E1	1E1 + 1EU
100 kHz to 3.2 GHz	+15	+23	+15	+23
100 kHz to 3.2 GHz w/UNX	+13	+23	+15	+23

Table 1-17 E8663D Maximum Levelled Power (dBm)^a

Frequency	All Models			
	Std.	1EU	1E1	1E1 + 1EU
100 kHz to 3.2 GHz w/1EH ^b	+13	+23	+15	+23
100 kHz to 3.2 GHz w/UNX + 1EH ^b	+12	+23	+15	+23
>3.2 GHz to 9 GHz	+15	+23	+14	+22

- a. Always check data sheet for updates to specifications
- b. With Option 1EH Low-pass Filters below 2 GHz switched off. With filters on, this specification applies above 2 GHz.

3. If the RF signal levels are good, most likely the problem is either a detector, ALC, or modulator. Before proceeding, turn ALC On and set the signal generator to maximum levelled power for the model and options you have and note the frequencies where the unlevelled condition occur. Later, when troubleshooting in ALC Off mode the unlevelled indication is turned off.
4. For each of the failed conditions listed, always start with the following signal generator settings:
 - ALC Mode ALC Off
 - Amplitude +30 dBm (max.)
 - Attenuator Hold Mod On (if Option 1E1 is installed)
 - RF On
 - Modulation Off

Conditions:

5. Unlevelled only between 250 kHz and 2 GHz. (Applies to all frequency options)
 If the unlevelled problem only occurs between 250 kHz and 2 GHz, the problem is most likely the A23 Lowband Coupler/Detector.
 - a. Checking the A23 Lowband Coupler/Detector:
 - Set the signal generator to 1.9 GHz or an unlevelled signal generator frequency.
 - Connect a power meter or spectrum analyzer to the A23 Lowband Coupler/Detector output.

- Set the signal generator to 1 GHz. Using the RPG, adjust the amplitude level so the detected voltage on cable J5 of A10 ALC (W14) is -0.117 Vdc. Using a power meter, measure the signal level at the end of the cable going to J3 of A30 Modulation Filter (W27). Use [Table 1-18](#) to determine the expected power level. If the power can not be adjusted to this level, troubleshoot the RF path.
- If the problem is at some frequency other than 1 GHz, repeat the above step using the problem frequency. The dB p-p variation from 250 kHz to 2 GHz should be < 2 dB.
- If the dc level is bad, replace the A23 Lowband Coupler/Detector.
- If the signal is good, replace the A10 ALC.

Table 1-18

Option	Expected Power Level
Standard	2.3 dBm \pm 0.5 dBm
UNW	4.5 dBm \pm 0.6 dBm
1EH	6.5 dBm \pm 1 dBm
UNW+1E H	9 dBm \pm 1 dBm

6. Unleveled only between 250 kHz and 3.2 GHz. If the unleveled problem only occurs between 250 kHz and 3.2 GHz, the problem is most likely the A8 Output or A10 ALC. (Applies to all frequency options)
 - a. Checking Lowband Modulator Drive signal:
 - Set the signal generator to a frequency between 250 kHz and 3.2 GHz. Set the amplitude so the power meter reads +21 dBm (or the maximum settable power) on cable W27 going to J3 on A30 Modulation Filter. If the power can not be set and options 1EH and/or UNW are installed, use the RF path block diagram to verify the power levels through each device.
 - Measure the voltage on the center pin on A31 Motherboard connector J1122. The voltage should be around +2.0 Vdc.
 - Reduce the amplitude setting to 0 dBm and the voltage on J1122 should move towards +0.15 Vdc.
 - If the voltages are not correct or do not change as power is changed, replace the A10 ALC.
 - If the voltage changes, replace the A8 Output.

7. Unleveled only between 2 GHz and the maximum frequency. If the unleveled condition occurs only for frequencies >2 GHz to the maximum frequency, the problem is most likely the A25 Highband Coupler/Detector. (Applies to all frequency options)

a. Checking the A25 Highband Coupler/Detector:

- Set the signal generator frequency to 19 GHz or a frequency where the signal generator is unleveled.
- Connect a power meter or spectrum analyzer to the RF output connector.
- Using the RPG, adjust the power to the highest level possible. This level will be either +9 dBm, +7 dBm, or +3 dBm, depending on the mix of installed options. If the power can not be adjusted to one of these levels, troubleshoot the RF path.
- Remove the cable from J3 on the A10 ALC and measure the dc voltage on the center pin of the cable. Use [Table 1-19](#) to determine the expected power level.
- Set the power level to 0 dBm and repeat the center pin measurement. The voltage should be $-5 \text{ mVdc} \pm 10 \text{ mVdc}$.
- If the voltages are good, go to step 8.
- If the voltages are the same, replace the A25 Highband Coupler/Detector.

Table 1-19

Power Level	Expected Voltage Level at J3 Center Pin
+9 dBm	$-30 \text{ mVdc} \pm 10 \text{ Vdc}$
+7 dBm	$-20 \text{ mVdc} \pm 10 \text{ Vdc}$
+3 dBm	$-10 \text{ mVdc} \pm 10 \text{ Vdc}$

8. Unleveled only between 3.2 GHz and 20 GHz. (Applies to all frequency options)

If the unleveled condition occurs between 3.2 GHz and 20 GHz, the problem is most likely the A30 Modulation Filter.

a. Checking the A30 Modulation Filter:

- Set the signal generator to 20 GHz or a frequency where the signal generator is unleveled and measured RF output level is +7 dBm or +3 dBm, depending on options. If the power can not be set to +7 dBm or +3 dBm, troubleshoot the RF path.

- Remove the cable going to J6 on the A30 Modulation Filter and measure the voltage on the center pin. The voltage should be approximately +5.4 Vdc.
 - Set the amplitude to –15 dBm. The voltage on the center pin should decrease a few mVdc.
 - If the voltages are good, replace the A30 Modulation Filter.
 - If the voltages are bad, go to step 7.
- b. If Option 540, measure the signal going into J3 and out of J2 on the A27 40 GHz Doubler. If the loss is greater than 2.5 dBm, replace the A27 40 GHz Doubler.
- c. If Option 550 or 567, measure the signal going into J3 and out of J2 on the A27 40 GHz Doubler. If the loss is greater than 2.5 dBm, replace the A36 Quadraplier.
- d. If Option 532 or 544, measure the signal going into J1 and out of J2 on the A37 Upconverter. The loss should be less than 5 dBm. If the loss is 5 dBm or greater, replace the A37 Upconverter.
9. Unleveled only between 20 GHz and 40 GHz or 44 GHz. If the unleveled condition occurs between 20 GHz and 40 GHz, the problem is either with the A27 40 GHz Doubler or the A25 Highband Coupler/Detector.
- a. Checking the A25 Highband Coupler/Detector:
- Using a spectrum analyzer, check at the RF output signal level to the level shown in the Maximum Leveled Power table. The RF output level must be greater than the maximum specified power level.
 - If the maximum power level is not greater than the maximum power level specified, troubleshoot the RF path starting with the signals out of the A30 Modulation Filter to the A27 40 GHz Doubler.
 - If Option 550 or 567, replace the A36 Quadraplier.
 - If Option 532 or 544, replace the A37 Upconverter.
 - If the signal is greater than the maximum specified power level, replace the A25 Highband Coupler/Detector.
10. Unleveled from >3.2 GHz to the maximum frequency.
- Option 540 – Using the RF path block diagram, check the output levels of the A29 20 GHz Doubler, the A30 Modulation Filter, and the A27 40 GHz Doubler.
- Options 550 and 567 – Using the RF path block diagram, check the output levels of the A29 20 GHz Doubler, the A30 Modulation Filter, and the A36 Quadraplier.

Option 532 and 544 – Using the RF path block diagram, check the output levels of the A35 20 GHz IQ Modulator, the A27 40 GHz Doubler, and the A37 Upconverter.

11. Unleveled at all frequencies.

If the signal generator is unleveled at all frequencies, the problem is most likely the A10 ALC.

a. Checking the A10 ALC:

- Run a complete self-test and troubleshoot the reported failure.

Troubleshooting Adjustment Problems

When an adjustment does not work or fails to resolve a problem and all self-tests have passed, use the following table to locate the most likely failure.

Table 1-20 Troubleshooting Help for Failed Adjustments

Adjustment that is failing...	Assemblies most likely causing failure...
ADC Calibration	A18 CPU
YIG-Driver Pre-Tune Calibration	A9 YIG Driver A28 YIG Oscillator A5 Sampler A6 Frac-N
VCO Bias Frac-N Calibration	A6 Frac-N
Internal Source Calibration	A11 Pulse/Analog Modulation Generator
AM Audio Path Offset Calibration	A11 Pulse/Analog Modulation Generator
KV vs. Frequency Calibration	A6 Frac-N
Timebase Calibration	A7 Reference
FM Scale Offset Calibration	A11 Pulse/Analog Modulation Generator
FM Path Offset Calibration	A11 Pulse/Analog Modulation Generator A6 Frac-N
FM In-band Offset Calibration	A6 Frac-N
FM Inverting Amplifier Offset Calibration	A6 Frac-N
FM 1/2 Path Ratio Gain Calibration	A11 Pulse/Analog Modulation Generator
Mod Source Relative Gain Calibration	A11 Pulse/Analog Modulation Generator
FM/PM Out-of-Band Calibration	A6 Frac-N
FM/PM YO Frequency Compensation Calibration	A9 YIG Driver A28 YIG Oscillator
DC FM Calibration	A6 Frac-N A11 Pulse/Analog Modulation Generator
Low Frequency Output Calibration	A11 Pulse/Analog Modulation Generator
External Input Peak Detector Calibration	A11 Pulse/Analog Modulation Generator
ALC Dynamic Calibration	A10 ALC A30 Modulation Filter A8 Output
Power Flatness Calibration	A10 ALC RF Path
ALC Modulator Calibration	A30 Modulation Filter A8 Output

Table 1-20 Troubleshooting Help for Failed Adjustments (Continued)

Adjustment that is failing...	Assemblies most likely causing failure...
Attenuator Calibration–Lowband and Highband Power	AT1 RF Path
Attenuator Calibration–Highband and High Power	AT1 RF Path
Attenuator Calibration–Lowband and Low Power	AT1 RF Path
Attenuator Calibration–Highband and Low Power	AT1 RF Path
AM Gain Calibration	A11 Pulse Modulation Generator
Gain Adjustment Bypass Calibration (Frequencies £ 3.2 GHz)	A8 Output A6 Frac–N
Pulse Width Calibration	A11 Pulse/Analog Modulation Generator A30 Modulation Filter A8 Output
IQ Impairment	A13 IQ Mux A35 3–20 GHz IQ Modulator A8 Output Cables between IQ Mux and IQ Modulators
9v PTAT	A10 ALC
Lowband Digital Pre–level Gain Calibration	A6 Frac–N
Lowband Digital Mixer Bias Calibration	A8 Output
Lowband Digital Gain Adjust	A8 Output
IQ Power Floor	A13 IQ Mux
Target IQ Power	A13 IQ Mux
I/F Corner	A13 IQ Mux A8 Output A35 3–20 GHz IQ Modulator A37 Upconverter
Upconverter Download	A37 Upconverter
RF Timing Skew	A14 Baseband Generator A13 IQ Mux A8 Output A35 3–20 GHz IQ Modulator A37 Upconverter
Baseband Generator Timing Skew	A14 Baseband Generator A13 IQ Mux
VBand Level Accuracy	AT1 Attenuator A24/25 67 GHz Coupler/Detector

Table 1-20 Troubleshooting Help for Failed Adjustments (Continued)

Adjustment that is failing...	Assemblies most likely causing failure...
Upconverter Gain Adjust Calibration	A37 Upconverter A35 3–20 GHz IQ Modulator
Modulator Bias DAC Sensitivity	A10 ALC A8 Output A30 Modulation Filter A36 Quadraplier A37 Upconverter

Troubleshooting ADC Adjustment Failures

The ADC adjustment adjusts the ADC reference voltage to match the A18 CPU +10 Vdc reference. There are three reasons the adjustment could fail:

- problems with the +10 Vdc reference
- A18 CPU problems
- analog mux on another assembly is starting to fail

Procedure:

- 1.** Run self-test 1100. If self-test 1100 passes, the +10 Vdc reference is good; proceed to step 2.
- 2.** To see if an analog mux is failing and loading the supply, turn power off and remove the A5 Sampler, A6 Frac-N, and A7 Reference.
- 3.** Run the adjustment. If the adjustment passes, turn power off, reinstall one assembly at a time and run the adjustment until the problem assembly is located.
- 4.** If self-test fails, turn power off, reinstall the assemblies and remove the A8 Output, A9 YIG Driver, and A10 ALC.
- 5.** Run the adjustment. If the adjustment passes, turn power off, reinstall one assembly at a time and run the adjustment until the problem assembly is located.
- 6.** If self-test fails, turn power off, reinstall the assemblies and remove the ribbon cable from J10 on the A26 MID (W35).
- 7.** If self-test passes, replace the A26 MID.
- 8.** If self-test fails, replace A18 CPU.

Troubleshooting Performance Test Problems

If a performance test fails and all self-tests pass, use the following to find the most likely failure:

Performance test that is failing...	Action to perform...
Maximum Levelled Output Power	Refer to “Troubleshooting the RF Path” on page 106.
Power Level Accuracy	Perform Power Flatness Calibration, Attenuator Calibration–Lowband and Highband Power, Attenuator Calibration–Highband and High Power, Attenuator Calibration–Lowband and Low Power, and Attenuator Calibration–Highband and Low Power.
Internal Pulse Modulation Level Accuracy Internal Pulse Modulation Rise/Fall Time Internal Pulse Modulation Minimum Pulse Width	If the frequency ≤ 3.2 GHz, check the A11 Pulse/Analog Modulation Generator or the A8 Output. If the frequency is >3.2 GHz, check A11 Pulse/Analog Modulation Generator and the A10 ALC. If the Internal Pulse Modulation Minimum Pulse Width test fails, perform a Pulse Width Calibration prior to replacing any assembly.
DC FM Carrier Offset	Perform DC FM Calibration. If still failing, check A11 Pulse/Analog Modulation Generator and A6 Frac–N.
External AM Frequency Response	If the frequency is ≤ 3.2 GHz, check the A11 Pulse/Analog Modulation Generator or the A8 Output. If the frequency is >3.2 GHz, check the A11 Pulse/Analog Modulation Generator and the A10 ALC.
Internal FM Frequency Response	Perform FM adjustments. If still failing check A11 Pulse/Analog Modulation Generator and A6 Frac–N.
External Phase Modulation Frequency Response	Perform FM adjustments. If still failing check A11 Pulse/Analog Modulation Generator and A6 Frac–N.
Internal FM Distortion	Perform FM adjustments. If still failing check A11 Pulse/Analog Modulation Generator and A6 Frac–N.
Internal Phase Modulation Distortion	Perform FM adjustments. If still failing check A11 Pulse/Analog Modulation Generator and A6 Frac–N.
External FM Deviation Accuracy	Perform FM adjustments. If still failing check A11 Pulse/Analog Modulation Generator and A6 Frac–N.
External Phase Modulation Deviation Accuracy	Perform FM adjustments. If still failing check A11 Pulse/Analog Modulation Generator and A6 Frac–N.

Troubleshooting
 Troubleshooting Performance Test Problems

Performance test that is failing...	Action to perform...
External Pulse Modulation ON/OFF Ratio	<p>If the frequency is ≤ 3.2 GHz, check the A11 Pulse/Analog Modulation Generator or the A8 Output.</p> <p>If the frequency is > 3.2 GHz, check the A11 Pulse/Analog Modulation Generator and the A10 ALC.</p>
Harmonic Spurious Sub-Harmonic Spurious	Refer to “Troubleshooting Harmonic Spurious” on page 111.
Non-Harmonic Spurious	Refer to “Troubleshooting Non-Harmonic Spurious” on page 116.
Single-Sideband Phase Noise	Refer to “Troubleshooting the RF Path” on page 106.
Internal EVM Digital Modulation Quality	Perform I/Q and digital calibrations.
Digital Modulation Power Relative to CW	Perform I/Q and digital calibrations.

Troubleshooting the RF Path

Troubleshooting RF Path procedure:

- preset the signal generator
- set a frequency
- open ALC loop (ALC Off)
- set signal generator to maximum power
- check power levels in the RF path using “**Troubleshooting RF Power Levels**”, below.

Troubleshooting RF Power Levels

The following information has been provided to aid in troubleshooting power levels in the RF path:

- RF Block Diagrams (see **Figure 1-9 on page 151** and **Figure 1-10 on page 153** for the E8257D, and **Figure 1-13 on page 159** and **Figure 1-14 on page 161** for the E8267D). The block diagrams show signal flow, path frequency ranges, and minimum power levels to a few key points in the RF path.
- A Gain/Loss table (**Table 1-28 on page 149**). The table provides the minimum gain or maximum loss level between the input and output for each part

When troubleshooting the instrument, the troubleshooting procedure may refer you to the RF Block Diagram, the Gain/Loss table, or both.

Examples:

Verifying the gain or loss of a part – Locate the part in the Gain/Loss table. Measure the output and input power levels. Subtract the input from the output to determine the gain or loss. If the part is not meeting the gains or losses specified (the gain is less than specified or the loss is more than specified), the part most likely needs to be replaced. In cases where the part fails to meet its specification but comes very close, calculate and measure the minimum input power level into the part before replacing the part.

Verifying the minimum power into a part – Locate a point on the RF path where output power is specified, then use the Gain/Loss table to calculate the minimum power level at the specific location. If the minimum power level is not present, measure the output of the first device showing a power level on the RF Block Diagram, then measure the input and output power level for each device in the path until the defective part is located.

ALC and RF problems

1. **Run a full self-test and troubleshoot any reported failures before proceeding.**

2. From Table 1-21, determine the frequencies where the problem occurs.

Table 1-21

Frequencies	Assemblies
All frequencies	A27 40 GHz Doubler (40 GHz models only) A28 YIG Oscillator A29 20 GHz Doubler A30 Modulation Filter AT1 (Option 1E1) RF Output Connector
250 kHz to 2 GHz	A6 Frac-N A8 Output A27 40 GHz Doubler A29 20 GHz Doubler A30 Modulation Filter A25 Highband Coupler/Detector AT1 (Option 1E1) RF Output Connector
250 kHz to 20 GHz	A23 Lowband Coupler/Detector A8 Output
3.2 GHz to 20 GHz/40 GHz	A27 40 GHz Doubler (40 GHz models only) A29 20 GHz Doubler A30 Modulation Filter AT1 (Option 1E1) RF Output Connector
20 GHz to 40 GHz	A25 Highband Coupler/Detector A27 40 GHz Doubler A30 Modulation Filter AT1 (Option 1E1) RF Output Connector

3. Perform the following steps:

- press Preset
- press Frequency, and set signal generator to frequency in problem area
- press Amplitude, and set to +25 dBm
- press RF ON/OFF (turn RF On)
- turn ALC Off
- Power Search Manual
- Do Power Search

4. Using the RF Path Block Diagram, check the power levels at the points shown.

5. Once the problem is located, verify that the cables between the two assemblies are good before replacing the assembly.

6. To measure the A6 Frac-N output level, with the signal generator on, remove the A8 Output and probe the right hand mmx connector's center pin. The power level should be $\geq +5$ dBm.

WARNING

Always turn the signal generator off before installing any assembly.

7. If power levels look good through the path in ALC Off mode, the problem is most likely in the ALC loop. Go to troubleshooting the ALC loop.

Troubleshooting Pulse Modulation

1. Verify a license key has been entered for either Option UNU or UNW.
2. Run a full self-test and troubleshoot any reported failures before proceeding.
3. Determine the frequency of the pulse modulation problem.
4. Configure the signal generator to the pulse modulation setting that produces the problem.
5. Connect an oscilloscope to the LF OUTPUT connector. The waveform should be present on the oscilloscope.
6. If the waveform is present, continue to step 7.
7. If the waveform is not present or the signal is not the correct amplitude or type, replace the A11 Pulse/Analog Modulation Generator.
8. Turn ALC Off. In ALC On mode, the ALC bandwidth limits pulse amplitudes at pulse widths $< 1\mu\text{s}$. If turning ALC Off corrects the problem, then verify that pulse modulation is setup in either ALC Off or Power Search Modes.

Troubleshooting Problems < 3.2 GHz

9. If the pulse modulation problem occurs at < 3.2 GHz, check P52-23 on the A31 Motherboard. Compare the results with [Table 1-22](#).

Table 1-22

Pulse On	Pulse Off
+5 Vdc	0 to +5 Vdc (pulses at modulation rate)

10. If signal levels are good, replace the A8 Output.
11. If the signals are bad, check the cable continuity. If the cable is bad, replace the cable. If the cable is good replace the A11 Pulse/Analog Modulation Generator.

Troubleshooting Problems >3.2 GHz

- 12.If the pulse modulation problem occurs >3.2 GHz, remove the cable A30 Modulation Filter J7 (W17). Probe the end of the cable. Compare the results with [Table 1-23](#).

Table 1-23

Pulse On	Pulse Off
+5 Vdc	0 to +5 Vdc (pulses at modulation rate)

- 13.If the signal levels are good, replace the A30 Modulation Filter.
- 14.If the signal levels are bad, check the cable continuity. If the cable is bad, replace the cable. If the cable is good replace the A11 Pulse/Analog Modulation Generator.

Troubleshooting AT1 Attenuator

The attenuator in a E8267D signal generator steps (changes levels) every 5 dBm. In a E8257D Option 520/532/540 signal generator the attenuator steps 5 dBm for the first change, then ever 10 dBm. In a E8257D 550/67 signal generator the attenuator steps every 10 dBm.

1. If the attenuator switches at the switch points but the power does not change or the power changes more or less than expected, replace the attenuator.
2. If the attenuator does not switch, press: **Utility > more 1 of 2 > Instrument Info > Options Info**
An Option 1E1 should be listed.
3. If Option 1E1 is not listed, the option is either not installed or the configuration file is bad. The signal generator will need to be returned to Keysight for service.
4. If Option 1E1 is listed, turn the signal generator off and remove W36 from J13 on the A26 MID.
5. Turn the signal generator on and probe the following pins on J13.
 - Pin 1 +15 Vdc \pm 0.75 Vdc
 - Pin 2 +5.2 Vdc \pm 0.5 Vdc

Table 1-24 shows the amplitude ranges and the corresponding attenuator switch control line voltages. Attenuation is switched in at +3 Vdc \pm 0.75 Vdc and switched out at 0 Vdc.

Table 1-24

Amplitude Levels	Pin Numbers and Voltages				
	J13-5 40B dB Atten. Step	J13-6 20 dB Atten. Step	J13-7 40C dB Atten. Step	J13-9 10 dB Atten. Step	J13-10 5 dB Atten. Step
+25 to +5.1 dBm	0	0	0	0	0
+5.0 to -4.99 dBm	0	0	0	0	+3
-5.0 to -14.99 dBm	0	0	0	+3	+3
-15.0 to -24.99 dBm	0	+3	0	0	+3
-25.0 to -34.99 dBm	0	+3	0	+3	+3
-35.0 to -44.99 dBm	+3	0	0	0	+3
-45.0 to -54.99 dBm	+3	0	0	+3	+3
-55.0 to -64.99 dBm	+3	+3	0	0	+3
-65.0 to -74.99 dBm	+3	+3	0	+3	+3
-75.0 to -84.99 dBm	+3	0	+3	0	+3
-85.0 to -94.99 dBm	+3	0	+3	+3	+3
-95.0 to -104.99 dBm	+3	+3	+3	0	+3
>-105.0 dBm	+3	+3	+3	+3	+3

6. If the voltages are correct, replace the attenuator.
7. If the voltages are not correct, replace the A26 MID.

Troubleshooting Harmonic Spurious

Harmonics are multiples of the output frequency. The second harmonic should be two times the output frequency at an x dBc down. This section contains procedures for checking spurious harmonic emission levels to make sure they are within specifications.

NOTE If the harmonic falls beyond the frequency range of the signal generator, the harmonic is not specified or measured.

To measure harmonics that fall within the signal generator frequency range, set the signal generator and spectrum analyzer to the harmonic frequency and set the signal generator to a specified power level. Measure the output signals peak power level on the spectrum analyzer. This peak power level is the reference level for the harmonic measurement. Turn on Marker Delta, set the signal generator to the fundamental frequency, and measure the power level of the fundamental frequency. The dBc value is the difference between the fundamental peak power level and the harmonic frequency power level.

Table 1-25 Harmonic Specifications

Harmonic Specifications	
< 10 MHz	-28 dBc
10 MHz to 2 GHz	-30 dBc
10 MHz to 2 GHz (with Option 1EH filters on)	-55 dBc
> 2 GHz to 20 GHz	-55 dBc
> 20 GHz to 40 GHz (Option 540)	-50 dBc
> 20 GHz to 44 GHz (Options 532 & 544)	-45 dBc
> 20 GHz to 67 GHz (Options 550 & 567)	-45 dBc

20 GHz Models

Use this procedure to troubleshoot harmonic problems with a fundamental frequency between 500 kHz and 3.2 GHz.

1. Set the signal generator as follows:

- Frequency: set to harmonic frequency to be measured
- Amplitude: +10 dBm
- ALC Off
- Amplitude Power Search (softkey)

2. Remove the cable on A30 Modulation Filter J3 (W27). Connect the spectrum analyzer to the cable.
3. Set the spectrum analyzer to the harmonic frequency, then press peak search and delta marker.
4. Set the signal generator to the fundamental frequency of the harmonic.
5. Using the delta marker, read the harmonic power level on the spectrum analyzer. Compare the spectrum analyzer reading to the specifications in [Table on page 111](#).
6. If the harmonics do not meet specifications, replace the A8 Output.
7. If harmonic meet specifications reconnect the cable to the A30 Modulation Filter J3 and remove the cable going to A30 Modulation Filter J2 (W31). Connect the spectrum analyzer to the A30 Modulation Filter J2.
8. Set the signal generator and spectrum analyzer to the harmonic frequency, then on the spectrum analyzer, press marker peak search and then delta marker.
9. Set the signal generator to the fundamental frequency of the harmonic.
10. Using the delta marker, read the harmonic power level on the spectrum analyzer. Harmonic level should be ≤ -55 dBc.
11. If the harmonic level is > -55 dBc, replace the A30 Modulation Filter.

20 GHz Models

Use this procedure to troubleshoot harmonic problems with a fundamental frequency between 3.2 GHz and 10 GHz.

1. Set the signal generator as follows:
 - Frequency: set to harmonic frequency to be measured
 - Amplitude: +10 dBm
 - ALC Off
 - Amplitude Power Search (softkey)
2. Remove the cable from the A29 20 GHz Doubler J2. Connect the spectrum analyzer to A29 20 GHz Doubler J2.
3. Set the spectrum analyzer to the harmonic frequency, press marker peak search and then delta marker.
4. Set the signal generator to the fundamental frequency of the harmonic.
5. Using the delta marker, read the harmonic power level on the spectrum analyzer. Compare the spectrum analyzer reading to the specifications in [Table on page 111](#).
6. If harmonics do not meet specification, replace the A29 20 GHz Doubler.

7. If harmonics meet or exceed specification, reconnect the cable to the A29 20 GHz Doubler J2 and remove the cable going to the A30 Modulation Filter J2 (W31). Connect the spectrum analyzer to the A30 Modulation Filter J2.
8. Set the signal generator and spectrum analyzer to the harmonic frequency. On the spectrum analyzer, press marker peak search and delta marker.
9. Set the signal generator to the fundamental frequency of the harmonic.
10. Using the delta marker, read the harmonic power level on the spectrum analyzer. Compare the spectrum analyzer reading to the specifications in [Table on page 111](#).
11. If the harmonics do not meet specification, replace the A30 Modulation Filter.

32 GHz and 44 GHz Models Only

Use this procedure to troubleshoot harmonic problems with a fundamental frequency between 10 GHz and 16 GHz for Option 532, and between 10 GHz and 22 GHz for Option 544.

1. Set the signal generator as follows:
 - Frequency: set to harmonic frequency to be measured
 - Amplitude: +10 dBm
 - ALC Off
 - Amplitude Power Search (softkey)
2. Remove the cable from the A37 20–44 GHz Upconverter (W102). Connect the spectrum analyzer to the A37 20–44 GHz Upconverter (J4).
3. Set the spectrum analyzer to the harmonic frequency, then press peak search and delta marker.
4. Set the signal generator to the fundamental frequency of the harmonic.
5. Using the delta marker, read the harmonic power level on the spectrum analyzer. Compare the spectrum analyzer reading to the specifications in [Table on page 111](#).
6. If the harmonics do not meet specifications, replace the A37 20–44 GHz Upconverter.

40 GHz Models Only

Use this procedure to troubleshoot harmonic problems with a fundamental frequency between 2 GHz and 20 GHz

1. Set the signal generator as follows:

- Frequency: set to harmonic frequency to be measured
 - Amplitude +10 dBm
 - ALC Off
 - Amplitude Power Search (softkey)
2. Remove the cable from the A30 Modulation Filter J2 (W31). Connect the spectrum analyzer to A30 Modulation Filter J2.
 3. Set the spectrum analyzer to the harmonic frequency and press marker peak search and delta marker.
 4. Set the signal generator frequency to the fundamental frequency of the harmonic.
 5. Using the delta marker, read the harmonic power level on the spectrum analyzer. Compare the spectrum analyzer reading to the specifications in [Table on page 111](#).
 6. If the harmonics do not meet specification, replace the A30 Modulation Filter.
 7. If the harmonics meet or exceed specification, reconnect the cable to the A30 Modulation Filter J2 and remove the cable going to A27 40 GHz Doubler output (W30). Connect the spectrum analyzer to the A27 40 GHz Doubler J2.
 8. Set the signal generator and spectrum analyzer to the harmonic frequency. Press marker peak search and delta marker.
 9. Set the signal generator to the fundamental frequency of the harmonic.
 10. Using delta marker, read the harmonic power level on the spectrum analyzer. Compare the spectrum analyzer reading to the specifications in [Table on page 111](#).
 11. If the harmonics do not meet specification, replace the A27 40 GHz Doubler.

50 and 67 GHz Models Only

Use this procedure to troubleshoot harmonic problems with a fundamental frequency between 20 GHz and 25 GHz for Option 550, and between 20 GHz and 33.5 GHz for Option 567.

1. Set the signal generator as follows:
 - Frequency: set to harmonic frequency to be measured
 - Amplitude +10 dBm
 - ALC Off
 - Amplitude Power Search (softkey)

2. Remove the cable from the A30 Modulation Filter output going to the A36 Quadraplier (W107). Connect the spectrum analyzer to A30 Modulation Filter (J2).
3. Set the spectrum analyzer to the harmonic frequency and press marker peak search and delta marker.
4. Set the signal generator frequency to the fundamental frequency of the harmonic.
5. Using the delta marker, read and record the harmonic power level on the spectrum analyzer.
6. Reconnect the cable to the A30 Modulation Filter (J2) and remove the cable from the A36 Quadraplier output (W112). Connect the spectrum analyzer to the A36 Quadraplier (J3).
7. Set the signal generator and spectrum analyzer to the harmonic frequency. Press marker peak search and delta marker.
8. Set the signal generator to the fundamental frequency of the harmonic.
9. Using delta marker, read the harmonic power level on the spectrum analyzer. There should be a decrease in the harmonic power level from what was measured in step 3, at the output of the A30 Modulation Filter. If there isn't, or if the decrease is less than 15 dB, replace the A36 Quadraplier.
10. If the harmonics are decreased, replace the A30 Modulation Filter.

Troubleshooting Non-Harmonic Spurious

There are nine different groupings a spur can fall into. The grouping determines what assembly is most likely generating the spur. The procedure for troubleshooting spurs is to identify the grouping based on failing a performance test, checking for loose or broken cables or castings, and replacing the assembly.

Table 1-26 Non Harmonic Spurs

Mixing Spurs	These spurs are generated by the mixing products of the RF and IF signals on the A8 Output. The instrument is tuned to a frequency in the Heterodyne-Band (250 kHz to 250 MHz) to measure these spurs.
Power Supply Spurs	These spurs are generated by the power supply switching at a 100 kHz rate. If the test fails for these spurs, change A19 Power Supply.
Offset Reference Spurs	These spurs are generated by the 10 MHz frequency reference on the A7 Reference.
Clock Spurs	Two clocks on the A11 Pulse/Analog Modulation Generator generate these spurs. The first clock is 33.554432 MHz and is used by the numeric synthesizer. The second clock is 100 MHz and is used by the internal pulse generator.
RF and LO Feedthrough Spurs	When the instrument is tuned to a Heterodyne Band (250 kHz to 250 MHz) frequency, the RF and LO feeds through from the mixer on the A8 Output generates spurs on the RF output.
Frac-N Feedthrough	These spurs are generated by the Frac-N frequency coupling onto the low-band signal as it leaves the A6 Frac-N. The spurs then appear at the Frac-N frequency at the RF output.
Sampler Spurs	These spurs are generated on the A5 Sampler by the sampler LO and IF frequencies.
Frac-N 250 MHz Crossing Spurs	These spurs are generated by either the A5 Sampler, A6 Frac-N, or A7 Reference. They occur when a harmonic of the Frac-N frequency equals a harmonic of 250 MHz. The spurs are measured in highband at 133 kHz offset from the CW frequency.
IF 250 MHz Crossing Spurs	These spurs are generated on the A5 Sampler. They are caused by harmonics of the A5 Sampler IF. The spurs are measured in highband at 133 kHz offset from the CW frequency.

Troubleshooting Option UNR/UNX/UNY and Instruments with Serial Prefixes \geq US4805/MY4805 Phase Noise

Poor grounds or shielding problems in either the test environment or the measurement system can cause the phase noise measurement to fail. Physical vibration is another common cause of phase noise. Before performing a phase noise measurement make sure all covers are installed, the work surface is free of physical vibrations, and the phase noise system is working properly.

Phase noise failures at specific offsets are fairly predictable. After making sure the measurement accurately reflects a failure, use **Table 1-27** to troubleshoot phase noise problems. The troubleshooting procedure consists of assembly substitution.

Table 1-27 Phase Noise Failures

Frequency Offset	Most Likely Assembly
0 to 100 Hz	A32 High Stability Time Base
100 Hz to 10 kHz	A7 Reference
<5 kHz to 10 kHz	A6 Frac-N; A45 Frac-N (Option UNY)
10 kHz to 100 kHz	A5 Sampler; A46 Offset (Option UNY)
>100 kHz to 1 MHz	A28 YIG Oscillator or A9 YIG Driver
Frequencies <3.2 GHz	A8 Output
Frequencies >3.2 GHz	A29 20 GHz Doubler or A30 Modulation Filter
Frequencies >20 GHz	A27 40 GHz Doubler

NOTE

In non-Option UNR/UNX and instruments with serial prefixes $>$ US4805/MY4805, the most likely assemblies and frequency offset are the same except for <100 Hz. In non-Option UNR/UNX and instruments with serial prefixes $>$ US4805/MY4805, the most likely assembly for <100 Hz offset is the A7 Reference.

Overall Description

The overall description provides a functional overview of the Keysight PSG signal generators. Some of the functional blocks discussed are common to many types of instruments, while others are more specific to analog and vector signal generators.

Common functions:

- A18 CPU
- A19 Power Supply
- Input/Output Interface

Specific signal generator functions:

- Frequency Generation
- Output Power Level/Automatic Leveling Control
- Analog Modulation (Option UNU Standard Pulse, UNW Fast Pulse, UNT AM/FM and Phase Modulation) and Digital Modulation

A18 CPU

The A18 CPU controls all activities in the signal generator:

- translating information entered from the front panel keys, LAN, GPIB, or Auxiliary Interface (RS-232) into machine-level instructions
- communicating translated instructions on the internal buses
- monitoring critical circuits for problems, such as unlevelled and unlocked conditions
- reporting (on the front panel display) any problems with critical circuits

A19 Power Supply

NOTE

The power supply has an internal line fuse that cannot be replaced. If the fuse opens, the power supply must be replaced.

Voltages

The main power supply converts line voltage (120 Vac or 240 Vac) to regulated dc voltages. Some of the required dc voltages are not directly available from the main power supply and are provided by re-regulating one of the main power supply voltages to the required voltage. This regulation can take place on any assembly and then routed to the required assemblies.

Line Module

The line voltage connects to the power supply through the A22 Line Module. Because the power supply automatically detects and adjusts to different line voltages, manual line voltage selection is neither necessary nor available.

Power Supply Thermal Sensors and fans

Two thermal sensors prevent the signal generator from overheating. One sensor is internal to the A19 Power Supply; the other sensor is on the A8 Output. If the signal generator goes into thermal shutdown, the amber and green LEDs on the front panel blink on and off.

There are two fans in the instrument. One fan cools the power supply. The other is a variable speed fan that increases and decreases its speed to regulate the instrument's internal temperature. For reliability, it is important to operate the instrument with the covers installed to ensure proper airflow and cooling.

Input/Output Interface

Front Panel

The signal generator accepts inputs through the front panel hardkeys and the display softkeys, and provides outputs on the front panel display, and through the RF output connector. Depending on the model, features, and options, the front panel may have modulation input/output BNC connectors installed but not operational if the option associated with that connector is not also installed.

When line voltage is present and the signal generator is in standby mode, the amber LED above the power switch lights. When the signal generator is in power-on mode, the green LED (also above the power switch) lights.

Hardkeys/Softkeys

The front panel has two types of keys:

Hardkeys are dedicated to specific functions, entering values for the most commonly used features, and controlling the display's contrast and intensity.

The front panel keypad uses a row and column configuration. Pressing a key makes a connection between a row and column. The row and column information is routed to the A18 CPU where it is interpreted, and the corresponding function executed.

Softkeys, located along the display, are used to select the function displayed to the left of the key (on the display). When a softkey is pressed, the displayed function changes.

A2 Display

A liquid crystal display (LCD) provides information about the instrument's settings and condition. The LCD requires a power supply, lighting, and data:

Troubleshooting
Overall Description

- The A4 inverter converts dc voltage to the ac voltage required by the display.
- A backlight (a bulb powered by the A4 Inverter) lights the display so that information is visible.
- The A18 CPU generates data, which is routed to the LCD through the A3 Power Switch assembly.
- To extend the life of the LCD, an available sleep mode turns the LCD off after a defined inactive period (no key presses or program commands) and turns it back on with any key press.

RF Output Connector

On 20 GHz instruments, the RF output connector is an APC 3.5 male or Type-N (Option 1ED). On models with output frequencies above 20 GHz and <50 GHz, the RF output connector is a 2.4 mm male. On models with output frequencies above 50 GHz, the RF output connector is a 1.85 mm male connector. Option 1EM moves **all** front panel connectors to the rear panel.

Rear Panel

The rear panel contains the power line module, LAN, GPIB, RS-232, and A20 Source Module Interface (SMI), scalar interface, and BNC connectors used for sweep interface. BNC and SMB connectors may be present on the rear panel but not operational if the option associated with that connector is not installed.

Frequency Generation

The YIG oscillator generates frequencies from 3.2 to 10 GHz.

Output Frequency	Oscillator Frequency	Path	Notes
< 250 MHz	3.2 to 10 GHz	Lowband path, and part of highband path	A6 Frac-N signal is mixed with a 1 GHz signal on the A8 output assembly; the difference is used to generate the lower frequencies.
250 MHz to 3.2 GHz	4 to 8 GHz		Oscillator output is divided by 2/4/8/16 on the A6 Frac-N assembly.

Output Frequency	Oscillator Frequency	Path	Notes
> 3.2 GHz	3.2 to 10 GHz	Highband path	<p>On all models, the 3.2 to 10 GHz oscillator output is doubled to achieve frequencies between 10 and 20 GHz.</p> <p>On analog models, the 10 to 20 GHz signal is doubled to achieve frequencies between 20 and 40 GHz.</p> <p>On vector models, frequencies between 20 and 44 GHz are developed using a 40 GHz doubler and an upconverter. The 10 to 20 GHz signal from the 20 GHz Doubler is doubled using the same 40 GHz Doubler used in analog models, and then used as the LO input to the A37 Upconverter. A 3.2 to 10 GHz signal from the 20 GHz Doubler is fed to the IQ side of the A37 Upconverter. Frequencies up to <28.5 GHz are the difference between the LO and IQ inputs to the upconverter and frequencies 28.5 GHz to 44GHz are the sum.</p> <p>In analog models with output frequencies >40 GHz, the output frequency is developed by replacing the A27 40 GHz Doubler with the A36 Quadraplier. The A36 Quadraplier doubles the 10 to 20 GHz signal to develop frequencies up to 40 GHz and then doubles >20 GHz signals to generate frequencies >40 GHz.</p>

Highband Path – Frequencies 3.2 GHz and Above

The output of the YIG oscillator (3.2 to 10 GHz) is routed to the A29 20 GHz Doubler microcircuit. Depending on the desired output frequency, the signal is routed either through a bypass circuit (for frequencies below 10 GHz), or through a frequency doubler circuit (for frequencies above 10 GHz). After the bypass or doubler circuits, the signal is amplified and filtered.

In analog models, the A29 20 GHz Doubler output is routed to the A30 Modulation Filter. The A30 contains amplitude and pulse modulators, amplifiers, and filters. In 40 GHz analog models, the A30 Modulation Filter output is routed to the doubler path of the A27 40 GHz Doubler for frequencies above 20 GHz, and to a bypass switch in the A27 40 GHz Doubler for frequencies up to 20 GHz. The output of the A27 40 GHz Doubler is connected to the A24 Highband Coupler and A25 Highband Detector, the optional AT1 attenuator, and the front panel RF output connector.

In analog models with output frequencies above 40 GHz, the A30 Modulator filter provides outputs for the two A36 Quadraplier inputs. One input is to a bypass circuit for frequencies from 250 kHz to 20 GHz. The other input takes a 10 to 20 GHz signal and doubles it to provide 20 to 40 GHz to a second doubler for frequencies above 40 GHz. The A36 Quadraplier's output then connects to the A24 Highband Coupler and A25 Highband Detector, to the optional AT1 attenuator, and to the front panel RF output connector.

In vector models, the 20 GHz Doubler output is routed to the A35 3–20 GHz I/Q Modulator and then to the A30 Modulation Filter. The A35 3–20 GHz I/Q Modulator contains I and Q modulation circuits used to transfer I/Q information to the RF signal.

In 20 GHz vector models, the output of the A30 Modulation Filter is routed to the A24 Highband Coupler and A25 Highband Detector, then through the AT1 attenuator to the front panel RF output connector.

In 32 and 44 GHz models, the A35 3–20 GHz I/Q Modulator routes two signals. One signal goes to the A27 40 GHz Doubler. The second signal goes to the IQ input of the A37 Upconverter. The output of the 40 GHz Doubler is then routed to the LO side of the A37 Upconverter.

Lowband Path – Frequencies Below 3.2 GHz

For frequencies below 3.2 GHz, the YIG oscillator output is tuned between 4 and 8 GHz. In analog models and 20 GHz vector models, the YIG oscillator output is routed to the A29 20 GHz Doubler microcircuit, where a portion of the signal is coupled off and routed to the A6 Frac–N. In vector models with output frequencies > 20 GHz, the A39 Coupler is added at the YIG oscillator output to couple the signal to the A6 Frac–N. A divider on the A6 Frac–N divides the 4 to 8 GHz signal to a frequency between 250 MHz and 3.2 GHz. This signal is then routed to the A8 Output assembly where it is amplified, filtered and modulated.

NOTE

The following paragraphs apply to E8257D instruments without Option 1EU, with serial prefixes < US4928/MY4928/SG4928, and all E8267D & E8663B instruments.

Frequencies below 250 MHz are generated on the A8 Output by mixing the output signal from the A6 Frac–N (between 1000 and 750 MHz) with a 1 GHz LO from the A7 Reference. In **vector** models, the A8 Output also contains the I/Q modulation circuit.

Option UNW (improved pulse performance below 3.2 GHz) adds a fast pulse modulator after the A8 Output. Option 1EH (reduced harmonics below 3.2 GHz) adds a filter assembly (A38 Low Band Switch Filter) after the A8 Output. If Option UNW is installed, 1EH is installed after the A8 Output and before the UNW assembly.

The 100 kHz to 3.2 GHz signal is routed to the A23 Lowband Coupler/Detector, and then switched into the highband path by a switch in the A30 Modulation Filter microcircuit. From this point, the low frequency signals flow to the front panel through the highband path.

NOTE

The following paragraph applies to E8257D instruments with Option 1EU and all E8663D instruments.

The A43 Amp Filter assembly is added to the low band RF path. The RF signal flow goes from the A8 Output board into the A43 Amp Filter and then into the A23 Low Band Coupler. The A43 Amp Filter induces the circuitry for Options UNU and UNW for frequencies from 250 MHz to 3.2 GHz, Option 1EH, Option 007, Option 1EU, and a divider circuitry used with Option UNX.

Frequency Control

CW Mode

The A9 YIG Driver, A18 CPU, A7 Reference, A5 Sampler, and A6 Frac-N establish frequency accuracy and stability. This circuitry is commonly referred to as a phase lock loop (PLL).

In CW operation, the A18 CPU programs the A9 YIG Driver pre-tune DAC to output a voltage that coarsely tunes the YIG oscillator to the desired frequency. The A18 CPU also sets the A6 Frac-N VCO and the A5 Sampler phase dividers and VCO to a frequencies such that when the A6 Frac-N, A5 Sampler signal, and the YIG oscillator signals are in phase, the output of the phase comparator is 0 volts, and the phase lock loop is at the desired output frequency. When the phases of these two signals (YO feedback and reference) are **not** the same (in phase), the output of the phase detector changes to some voltage other than 0 volts.

The phase detector output is then integrated (the integrator voltage is proportional to the frequency error), and routed to the A9 YIG Driver where it is summed with the pre-tune DAC voltage, causing the YIG's output frequency to change. Once the phase of the two signals matches, the phase detector output voltage returns to 0 volts, and the integrator maintains a constant output voltage, holding the YIG output frequency constant.

To perform a phase comparison between the A6 Reference signal and the RF signal coupled off by the A20 Doubler, a sampling function on the A5 Sampler converts the RF (in GHz) to an IF frequency in the MHz range. A 10 MHz signal from the A7 Reference Assembly is used as the reference to the A6 Frac-N VCO (Voltage Controlled Oscillator) to maintain the A6 Frac-N frequency accuracy. The frequency reference for the A7 Reference can be an:

- external 10 MHz signal
- internal standard 10 MHz OCXO (Oven Controlled Crystal Oscillator) on the A7 Reference
- optional high-stability 10 MHz OCXO

In summary:

- The A18 CPU coarse tunes the YIG, and sets the A5 Sampler VCO frequency and the A6 Frac-N VCO frequencies.
- The A5 Sampler and A6 Frac-N VCO frequencies are not fixed, and vary according to the YIG frequency.
- In some modes, the A6 Frac-N's VCO is divided on the A5 Sampler.
- The A5 Sampler converts the RF signal to an IF signal for phase comparison.

- After a phase detector determines the phase difference between the two signals, the phase detector output is integrated. The integrated voltage is summed with the A9 YIG Driver pre-tune DAC voltage, causing the YIG oscillator output frequency to change to the desired frequency.

Ramp Sweep Mode (Option 007)

The A9 YIG Driver, A18 CPU, A7 Reference and the A6 Frac-N are used in sweep mode, but the A5 Sampler is not. The A9 YIG Driver does the following:

- generates the sweep rate
- sets the start frequency
- generates the sweep ramp
- provides delay compensation
- adjusts the ALC leveling reference for improved power flatness during sweep

The A6 Frac-N contains the phase lock circuitry required to monitor and maintain phase lock during sweep. It also provides a correction frequency voltage to the A9 YIG Driver.

Output Power Level/Automatic Leveling Control

The output power control circuitry, commonly referred to as the ALC loop, comprises the following:

- Two detectors: the A23 Lowband Coupler/Detector (frequencies ≤ 2 GHz) and the A24 Highband Coupler/A25 Highband Detector (frequencies > 2 GHz). Note: this is not the same frequency breakpoint as defined by the lowband and highband paths.

The couplers couple off a small portion of the RF signal and route it to the detectors. The detectors convert the RF signal to a dc voltage proportional to the RF power level. This dc voltage is routed to the A10 ALC and used to adjust the output power.

- An ALC assembly (A10)
- Two ALC modulators

In ALC leveling on (closed loop operation), the output level is detected and a voltage fed back and compared to a reference voltage. The output of the comparator controls the modulator drive current, which controls the output power level. When the detected and reference voltage levels are the same, the modulator drive current remains constant. When the detected and reference levels are not the same, the modulator drive current changes, causing the RF output power to increase or decrease until the reference and detected voltages are the same.

In ALC leveling off (open loop operation), only a reference voltage is used to control the modulation drive current. The comparator output is the sum of the reference voltage and stored calibration data for that frequency point; no feedback is provided. The stored calibration data is correction information stored in the instrument during power level calibration; it adjusts for any losses

that occur after the coupler/detector. The reference voltage is generated on the A10 ALC by a DAC, the output voltage of which is the result of the power level set on the front panel.

Leveling during ramp sweep (Option 007)

In ramp sweep mode, a sweep compensation reference voltage is routed from the A9 YIG Driver assembly to the A10 ALC to improve leveling during sweep operation. The A18 CPU controls the ALC reference correction DAC on the A9 YIG Driver.

Analog Modulation (Option UNU Standard Pulse, UNW Fast Pulse, UNT AM/FM and Phase Modulation)

All modulation functionality is license keyed. Without a license key entered into the instrument, the instrument will not provide any pulse, amplitude, frequency, or phase modulation. Two levels of pulse modulation performance are offered. Pulse Option UNU provides pulse widths of 150 ns or greater for frequencies at or above 3.2 GHz, 500 ns or greater for frequencies below 3.2 GHz, and with ALC off or in search mode, 1 ns or greater for frequencies at or above 3.2 GHz, and 2 ns or greater for frequencies below 3.2 GHz with ALC on. Pulse option UNW provides pulse widths of 20 ns or greater for all frequencies with ALC off.

The RF can be modulated using either external or internal signals from the A11 Pulse/Analog Generator. The A11 Pulse/Analog Generator includes a pulse generator and a numeric synthesizer that provides AM, FM, PM, and pulse modulation capabilities. For better phase modulation control, the internal generator is tied to the A7 Reference 10 MHz.

Internally generated signals up to 1 MHz can be switched to the LF Output BNC on the front panel.

A11 Pulse/Analog output signals are routed as follows:

Modulation Type	Routed to
Amplitude	A10 ALC
Pulse	A30 Modulation Filter A8 Output A36 Quadraplier A37 Upconverter
Frequency and Phase	A6 Frac-N

Digital Modulation

Digital I/Q modulation is generated on the A8 Lowband Vector Output and A35 3–20 GHz I/Q Modulator assemblies. The A13 I/Q Multiplexer routes the I/Q modulation to the A8 and A35. The source of the modulation may be provided externally via the front panel I/Q inputs or via the rear panel Wideband I/Q (Option 015) inputs. For signal generators with Option 601 or 602, the internal

A14 Baseband Generator may be used as the source of the I/Q modulation. The A13 I/Q Multiplexer also routes the baseband I and Q, along with their inverses, to the rear panel.

Baseband Generator (Option 601 or 602)

Option 601 or 602 provides the signal generator with a baseband generator and arbitrary waveform generator (ARB). The A14 Baseband Generator provides built-in basic waveform creation capability (QAM, FSK, PSK, etc.). The ARB enables users to generate their own waveforms and download them for playback. Option 601 provides 8 Msamples of playback memory, and Option 602 provides 64 Msamples of playback memory. The A14 Baseband Generator is also capable of generating two-tone or up to 64 multitones within its RF modulation bandwidth.

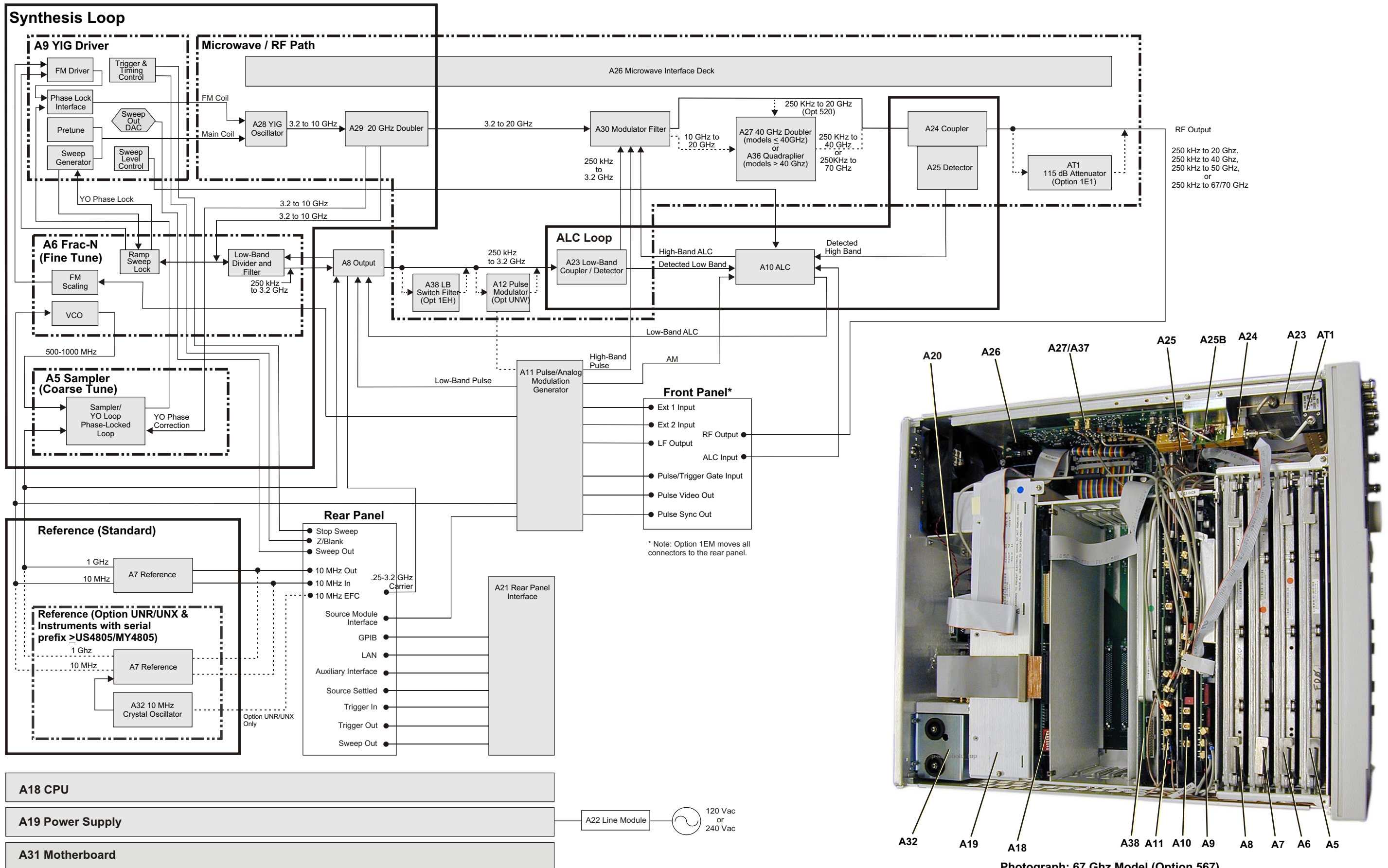

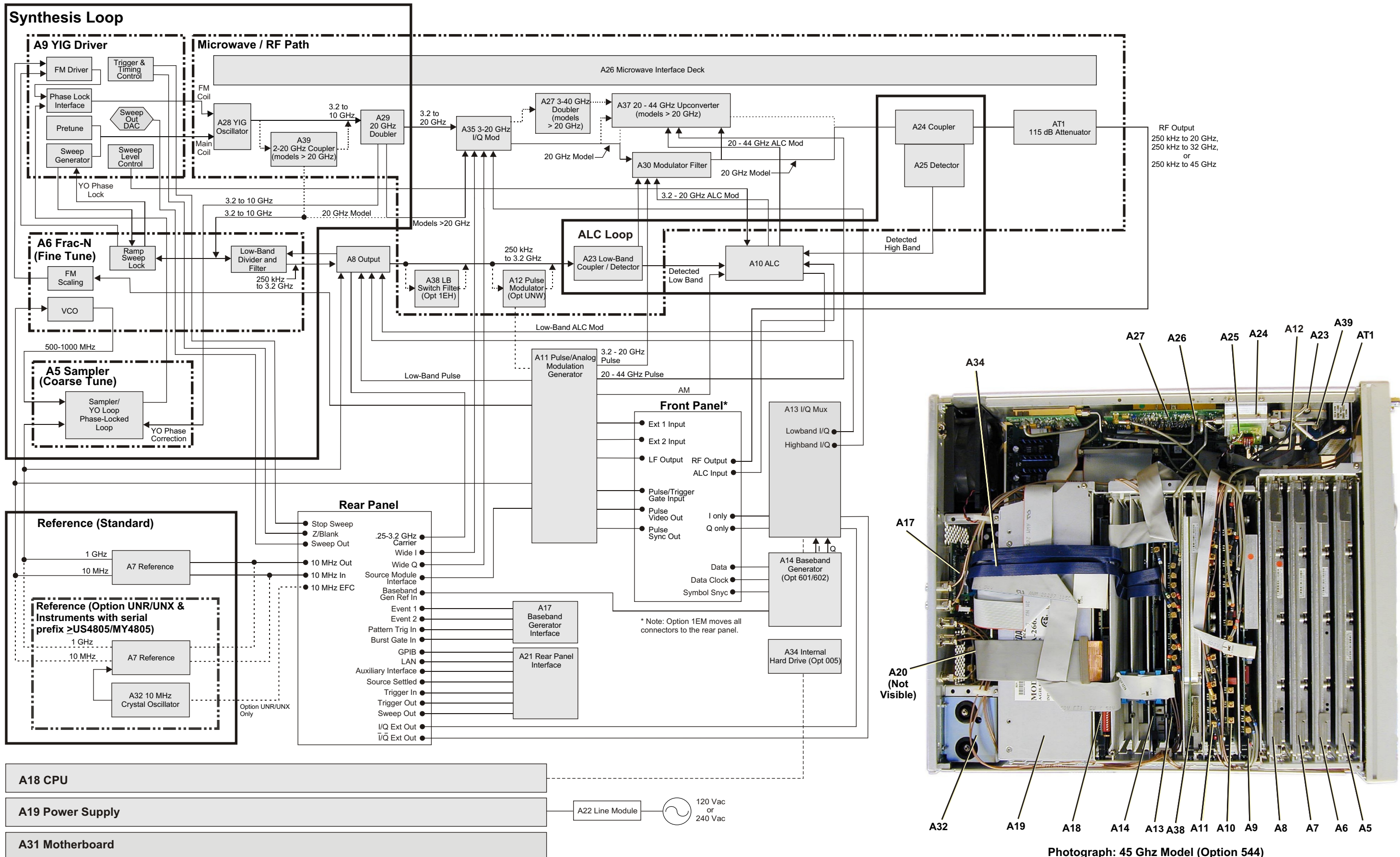

Reference/Synthesis Loop Description

This description covers generating CW and swept signals at frequencies from 3.2 to 10 GHz. For information on generating other frequencies, see the **“Overall Description” on page 118**.

The Reference/Synthesis Loop establishes the frequency characteristics of the signal generator. Frequency requirements include the following:

- fundamental frequency range generation
- phase noise
- frequency accuracy
- sweep rate (in sweep mode, Option 007)
- swept frequency accuracy (in ramp sweep mode, Option 007)

Reference/Synthesis Loop Hardware

In **CW** operation, the hardware used includes the A7 Reference, A5 Sampler, A6 Frac-N, A7 Reference, A9 YIG Driver, A28 YIG Oscillator (YO), and A29 20 GHz Doubler.

In **sweep** mode, the A5 Sampler is not used.

CW Mode

The following two basic functions are used to generate an accurate frequency:

- coarse and fine tuning
The Pre-tune DACs on the A9 YIG Driver provide coarse tuning; the A5 Sampler and A6 Frac-N assembly provide fine-tuning.
- frequency monitoring or feedback

Example (5 GHz CW)

The A18 CPU sets the A9 YIG Driver Pre-tune DAC to a value such that the YIG oscillator output is approximately 5 GHz (within approximately 3 MHz of the set frequency). The A18 CPU also sets the A5 Sampler VCO and the A6 Frac-N VCO frequencies to the values necessary to generate a 5 GHz YIG Oscillator output.

The A29 20 GHz Doubler receives the output of the YIG oscillator, and couples off and routes a portion of the signal to the A5 Sampler.

On the A5 Sampler, the VCO output samples the 5 GHz from the A29 20 GHz Doubler and converts it to an IF frequency between 30 and 64 MHz. The IF signal is then filtered and routed to a phase detector.

The output of the VCO on the A6 Frac-N is also routed to the A5 Sampler, where a divide circuit generates the phase detector reference frequency.

At this point, the reference IF and the sampled IF are approximately at the same frequency/phase. When the two signals are in phase, the output of the phase comparator is 0 volts. If the two signals are not in phase, the phase detector generates a voltage proportional to the phase (frequency) difference or error.

The phase detector error voltage is integrated and summed with the YIG oscillator pre-tune voltage on the A9 YIG Driver, fine tuning the YIG oscillator output to exactly 5 GHz.

Ramp Sweep (Option 007)

The following basic functions are required to generate an accurate sweep in ramp sweep mode:

- coarse and fine tune
- sweep rate control
- sweep generation
- output frequency monitoring or feedback

Example (start 3.2 GHz, stop 10 GHz, sweep rate 50 ms)

The A18 CPU sets the A9 YIG Driver Sweep DAC for a +3.2V output, which results in a YIG oscillator output of approximately 3.2 GHz. To sweep the instrument from 3.2 to 10 GHz, a programmable counter on the A9 YIG Driver increments the Sweep DAC's output to +10V.

The speed at which the output of the Sweep DAC changes determines the instrument's sweep rate. The rate of change is controlled by the output frequency of a digitally developed synthesis (DDS) chip on the A9 YIG Driver. The A18 CPU sets the DDS output to a frequency between 0 and 25 MHz, and the DDS output frequency clocks a programmable counter that drives the Sweep DAC rate of change. A low DDS frequency produces a slow sweep rate; a high DDS frequency produces a high sweep rate.

In ramp sweep mode, the A9 YIG Driver Pre-tune DAC is set to 0V. Delay compensation is added to improve linearity, and a fine tune correction from the A6 Frac-N is summed with the Sweep DAC voltage to maintain phase lock. The phase lock correction voltage is generated on the A6 Frac-N by coupling off some of the YIG output frequency in the A29 20 GHz Doubler, and routing it to the A6 Frac-N. On the A6 Frac-N, fixed and programmable dividers (controlled by the A18 CPU) divide the RF signal down to 5 MHz.

Also on the A6 Frac-N, 10 MHz from the A7 Reference is divided down to 5 MHz. The phase of the two 5 MHz signals is compared and integrated. The integrator's output is routed to the A9 YIG Driver and summed with the Sweep DAC (YIG Drive) voltage to maintain phase lock during sweep.

After the A18 CPU has everything set up, the A9 YIG Driver programmable counter is enabled and sweep begins. The A6 Frac-N divide numbers determine how far the A6 Frac-N sweeps before the A18 CPU calculates new divide numbers. The A6 Frac-N divide numbers are updated at filter switch points and at band crossings. During multiple band sweeps, the A9 YIG Driver Sweep DAC, DDS, and delay compensation are updated at band crossings.

A5 Sampler (CW mode only)

The A5 Sampler contains a microwave sampler used to convert a portion of the YIG oscillator output frequency to an IF frequency for phase comparison.

The A5 Sampler VCO provides the LO input to the sampler and the YIG oscillator provides the RF input. The VCO is phase locked to the 1 GHz reference board output. The 1 GHz signal is split into 2 paths. One path is divided by 4 and mixed with the other path to generate a 750 MHz signal. The 750 MHz signal is then split into 2 paths, one of which is divided down and input to a phase detector. The other path goes through a low pass filter and becomes the LO side of the mixer. The RF side of the mixer is the sampler VCO output. The mixer IF output then passes through a 155 MHz low pass filter and into the sampler phase detector. If the divided down 750 MHz path and the mixer output do not agree, a sampler lock is reported.

The A5 VCO output frequency (LO input) is set between 618 and 905 MHz, the RF input is between 3.2 and 10 GHz and the sampler output is an IF signal between 30 and 64 MHz. The IF signal passes through an 80 MHz low pass filter, eliminating all signals above 80 MHz that might pass through the sampler.

The IF signal is one input to a phase comparator. The second input to the phase comparator is 10 to 80 MHz, and is the result of dividing or mixing the 500 to 1000 MHz signal from the A6 Frac-N VCO. The output of the phase comparator is a voltage proportional to the difference in phase that is integrated and summed with the pre-tune voltage on the A9 YIG Driver, fine tuning the YIG oscillator to the desired frequency.

The sampler contributes to the phase noise at offsets between 10 KHz and 100 KHz. Phase noise is better in FM off mode than in FM on mode. In off mode the A6 Frac-N VCO signal on the A5 Sampler is divided down to get the phase comparator reference frequency of 10 and 80 MHz. In FM on mode, and for FM rates above 230 Hz, phase noise performance degrades because the A6 Frac-N VCO uses a mixer (required for higher FM rates) to get to the reference frequency.

A6 Frac-N

CW Mode

The A6 Frac-N uses a dividing technique to set the YIG Oscillator to the desired frequency. Because the A6 Frac-N VCO output is the phase reference for the comparator on the A5 Sampler, small changes in the Frac-N programmable divider number result in small changes in the A6 Frac-N VCO output frequency, which result in small changes in the YIG Oscillator frequency.

The A6 Frac-N can contribute to phase noise between 5 and 10 KHz. This overlaps with the frequencies over which the A7 Reference contributes to phase noise. There is no easy way to identify if a phase noise problem in the overlapping area is generated by the A6 Frac-N or A7 Reference, other than to try new assemblies.

FM Mode

FM rates up to 230 Hz are accomplished by combining the FM signal and the A6 Frac-N VCO tune signal to drive the YIG Driver main coil.

FM rates above 230 Hz are accomplished using the FM drive circuit on the A9 YIG Driver to drive the FM coil in the YIG Oscillator.

Sweep Mode

The A6 Frac-N maintains phase lock in sweep mode by providing the frequency correction voltage; in CW mode the A5 Sampler provides the frequency correction voltage.

On the A6 Frac-N, the RF signal is downconverted to 5 MHz using fixed and programmable dividers. The RF 5 MHz is compared to a 5 MHz reference developed by dividing 10 MHz from the A7 Reference by 2. The difference in phase is integrated and a correction voltage is applied to the crossover circuit on the A9 YIG Driver. By using programmable dividers, the RF side of the comparator can be kept at 5 MHz while the RF frequency sweeps. Because the instrument can maintain phase lock while sweeping over a finite frequency range, the A6 Frac-N divide numbers are changed at filter switch points and band crossings.

A7 Reference

Clean and stable reference signals are essential for low phase noise. In this case, two reference signals are provided:

- 1 GHz (to the A5 Sampler and the A8 Output, for down conversion)
- 10 MHz (to the A6 Frac-N for VCO phase coherency, and the A9 YIG Driver for DDS clock and baseband generator accuracy).

The standard A7 Reference uses a 1 GHz STW Oscillator and 10 MHz OCXO.

The **low phase noise** A7 Reference (Option UNR/UNX) uses a 100 MHz VCXO that is multiplied by 10 to achieve 1 GHz, and a high performance 10 MHz OCXO.

The A7 Reference contributes to phase noise between 100 Hz and 10 KHz. See the “**A6 Frac-N**” assembly description on [page 133](#), for more information on phase noise.

A9 YIG Driver

CW Mode

The A9 YIG Driver provides the A28 YIG Oscillator tune voltage. Coarse tuning of the A28 YIG Oscillator occurs when the A18 CPU sets the pre-tune DAC's output voltage to a value that sets the YIG oscillator frequency close to the desired frequency. 3.2 volts out of the pre-tune DAC results in a 3.2 GHz YIG oscillator output. The A28 YIG Oscillator output (in GHz) is proportional to the pre-tuned DAC output (in volts).

The A6 Frac-N and A5 Sampler compare the phase of a reference signal and the YIG oscillator frequency. A correction voltage is generated and summed with the pre-tune voltage on the A9 YIG Driver, which fine tunes the A28 YIG Oscillator to the desired frequency. For higher rate FM operation, the FM signal is scaled and the gain calibrated on the A9 YIG Driver before being used to drive the FM coil in the A28 YIG Oscillator.

Both the A9 YIG Driver and the A28 YIG Oscillator contribute to phase noise between 100 KHz and 1 MHz.

Ramp Sweep Mode (Option 007)

In sweep mode the A9 YIG Driver provides the tune voltage for the YIG oscillator, generates the sweep voltage, and provides the ALC Reference correction used during sweep.

The A9 YIG Driver has two similar circuits that generate:

- rear panel sweep out signal
- YIG sweep voltage

The hardware in these two circuits is identical, and includes:

- a sweep rate clock that is a digitally developed synthesis (DDS) chip with an output frequency of 0 to 25 MHz. A 10 MHz signal from the A7 Reference maintains the DDS frequency accuracy, and its output frequency clocks the programmable counter at its output rate.
- a programmable counter that can count either up or down; its output increments the sweep DAC.
- a sweep DAC

In the rear panel Sweep Out circuit, the DDS frequency is set so the programmable counter output increments the sweep DAC at the desired sweep rate. The programmable counter in the Sweep Out circuit always increments the sweep out DAC from 0 to +10V.

Because the output frequency can be equal to, a fraction of, or a multiple of the YIG oscillator frequency, the frequency of the DDS in the YIG Drive circuit changes during a sweep so the RF output frequency always sweeps at the desired sweep rate. The amount the programmable counter increments the sweep DAC depends on the required tune voltage. The YIG tunes from the start

frequency to either the stop frequency or a band crossing. The Sweep DAC sets the start frequency, and the sweep DAC output voltage directly relates to the YIG output frequency:

- If sweep DAC output = 5V, YIG frequency = 5 GHz
- If sweep DAC output = 10V, YIG frequency = 10 GHz

Signals that are summed with the sweep DAC voltage include:

- delay compensation, which is calculated by the A18 CPU and is dependent on the sweep rate and frequency band
- YIG pre-tune (the pre-tune DAC is always set to 0 volts in sweep mode)
- frequency correction voltage from the A6 Frac-N, which is dependent on the amount of frequency correction required

A28 YIG Oscillator (YO)

The A28 YIG Oscillator output frequency (3.2 to 10 GHz) is controlled by the amount of current through the main and FM coils. The main coil is used to set the frequency and for FM ≤ 230 Hz. The FM coil is used for FM rates > 230 Hz.

Both the A9 YIG Driver and the A28 YIG Oscillator contribute to phase noise between 100 KHz and 1 MHz.

A29 20 GHz Doubler

The A29 20 GHz Doubler provides:

- a thru path for output frequencies from 3.2 to 10 GHz
- two internal couplers that provide a 3.2 to 10 GHz signal to both the A6 Frac-N for phase locking during sweep operation, and to generate frequencies ≤ 3.2 GHz; and the A5 Sampler to provide the feedback needed for fine tune correction in CW mode
- a doubler path to generate frequencies from 10 to 20 GHz
- RF signal amplification and filtering

Both the A29 20 GHz Doubler and the A30 Modulation Filter contribute to phase noise > 3.2 GHz.

A38 Switch Filter and A43 Lowband Amp Filter (Option 1EH)

The A38 and A43 assemblies provide reduced harmonics below 3.2 GHz. The assemblies contain low pass filters that are switched in at different frequencies. The switch filter has several modes. In the CW and analog modulation modes, filters are on between 250 MHz and 2 GHz, with reduced power between 10 MHz and 2 GHz. In ramp, step and list sweep modes, filters are on between 250 MHz and 2 GHz, with reduced power between 250 MHz and 2 GHz. In IQ mode, filters are on between 10 MHz and 2 GHz, with reduced power between 10 MHz and 2 GHz, and degrade IQ bandwidth.

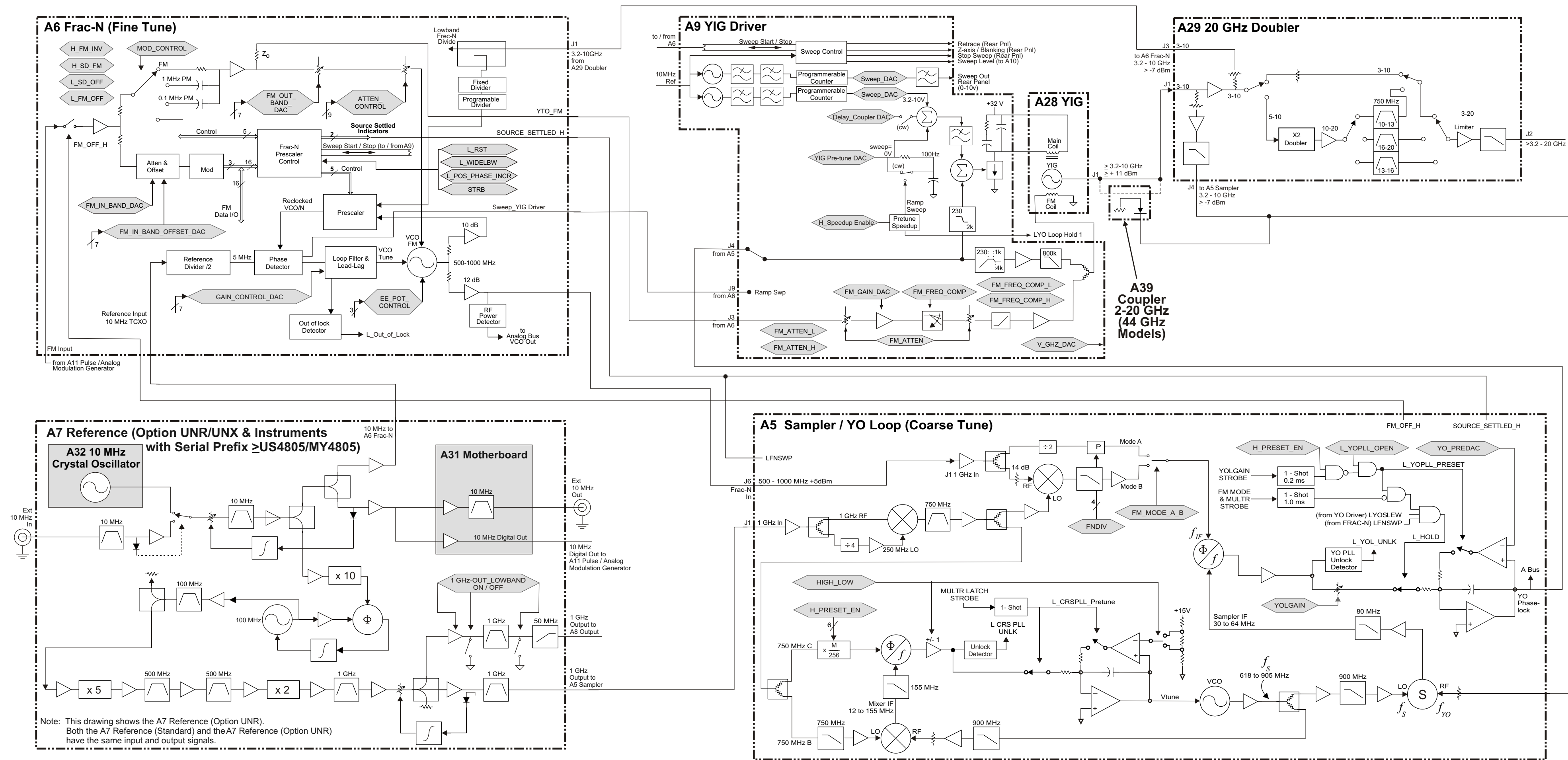

RF Path Description (Frequency Generation, Level Control, and Modulation)

The RF path can divide, pass through, and multiply the A28 YIG Oscillator (YO) signal to generate the desired RF frequency. Depending on models and options, the RF path includes hardware for amplitude, pulse, and digital (I/Q) modulation and controls the RF output power level. The Synthesis /Reference Block Description provides additional information on generating fundamental frequencies of 3.2 GHz to 10 GHz.

All RF signals originate from the A28 YIG Oscillator (YO) output frequencies of 3.2 GHz to 10 GHz. RF output frequencies below 3.2 GHz are generated by dividing the YO signal on the A6 Frac–N and A8 Lowband Output assembly. RF output frequencies between 3.2 and 10 GHz pass through the A29 20 GHz Doubler. RF output frequencies between 10 to 20 GHz are generated by doubling the 5 to 10 GHz YO signal in the A29 20 GHz Doubler. In 40 GHz analog models, RF output frequencies above 20 GHz are generated by doubling the 10 to 20 GHz signal output of the A29 20 GHz Doubler in the A27 40 GHz Doubler. In analog models with output frequencies greater than 40 GHz, the A27 40 GHz Doubler is replaced with the A36 Quadraplier. The A36 Quadraplier generates all frequencies above 20 GHz. The A36 Quadraplier contains two doublers. The first doubler is a 40 GHz doubler that doubles the 10 to 20 GHz from the A30 Modulation Filter to generate frequencies between 20 and 40 GHz. The second doubler in the A36 Quadraplier doubles frequencies above 20 GHz (from the 40 GHz doubler) to generate frequencies above 40 GHz.

In vector models with frequencies above 20 GHz, the RF output is generated using the A37 Upconverter. The A37 Upconverter contains a mixer, band pass filters, ALC and pulse modulation diodes, and amplifiers. The A27 40 GHz Doubler is used to generate a 20 to 40 GHz LO input to the A37 Upconverter. The input to the A27 40 GHz Doubler is an 11.4 to 19 GHz signal out of the A35 3–20 GHz IQ Modulator. A 5.7 to 9.5 GHz output from the A35 3–20 GHz IQ Modulator is used for the A37 Upconverter IQ input. For frequencies of 20 to 28.5 GHz, the difference product from the mixer is used and between 28.5 and 44 GHz, the summing mixing product is used.

Analog Model Hardware

In analog models, the RF Path comprises the following:

- A6 Frac–N
- A8 Output
- A12 Fast Pulse Modulation (Option UNW)
- A27 40 GHz Doubler (40 GHz models)
- A29 20 GHz Doubler
- A30 Modulation Filter
- A36 Quadraplier (> 40 GHz models)
- A38 Switch Filter (< 3.2 GHz if Option 1EH is installed)
- A43 Lowband Amp Filter
- AT1 Attenuator (if Option 1E1 is installed). Analog models have a 90 dB step attenuator and vector models have a 115 dB step attenuator.

Analog model option hardware includes:

- a removable compact flash drive¹ (Option 008) for external waveform storage

Vector Model Hardware

In **addition** to the analog hardware, vector models add the following hardware:

- A13 I/Q Multiplexer
- A27 40 GHz Doubler (> 20 GHz models)
- A35 3–20 GHz I/Q Modulator
- A37 44 GHz Upconverter (> 20 GHz models)

Vector model option hardware includes:

- a baseband generator (Option 602) for internal I/Q waveform generation
- an internal hard drive² (Option 005) for internal waveform storage (discontinued)
- a removable compact flash drive³ (Option 009) for external waveform storage

Assemblies that differ between vector and analog models include:

- an A8 Output assembly that includes an I/Q modulator for frequencies below 3.2 GHz
- an A19 Power Supply and A31 Motherboard that can handle increased power requirements
- an A26 Microcircuit Interface Deck and front and rear panels that provide the digital interface

A6 Frac–N

The A6 Frac–N is part of the Synthesis Loop **and** the RF lowband path.

The RF signal from the A29 20 GHz Doubler is amplified, filtered, divided (dividers generate RF output frequencies below 3.2 GHz), and then amplified again before being routed to the A8 Output.

The A8 Output provides the A6 Frac–N a pre–level bias voltage to maintain the required RF output level to the A8 Output assembly.

Troubleshooting note: To check the A6 Frac–N RF output level to the A8 Output, remove the A8 Output from the signal generator while the signal generator is powered on. If the A8 Output is removed while the power is on, the pre–level bias is maintained on the A6 Frac–N, maintaining the RF power level on the A6 Frac–N output. Turn the instrument off before reinstalling the A8 Output.

1. Instruments with serial prefix \geq 4829.
2. Instruments with serial prefix $<$ 4829.
3. Instruments with serial prefix \geq 4829.

A8 Output

Analog

The A8 Output is in the RF lowband path; it provides:

- pre-level bias voltage to the RF output level control on the A6 Frac-N
For frequencies up to 3.2 GHz, the ALC diode controls the RF output power level. Without bias applied to the ALC diode, the output power goes to the maximum level. In closed-loop operation, the A10 ALC uses a negative voltage from both the A23 (< 2 GHz) and A24/25 (>2 GHz) coupler/detectors to control the ALC diode's bias.
- pulse modulation
Pulse modulation (RF pulsed on) is achieved by applying +5 Vdc to the pulse circuitry on the A8 Output. +5 Vdc turns the RF signal on; removing the +5Vdc turns the RF signal off. In instruments with Option UNW (fast pulse) the pulse modulation input cable is moved from the A8 Output to the A12 Fast Pulse Modulator and the A8 diode is biased on.
- amplitude modulation
- the circuitry to generate under-range frequencies (<250 kHz)
Under-range frequencies are the result of mixing the A6 Frac-N RF signal with a 1 GHz signal from the A7 Reference and using the difference between the two signals for the output. The A8 Output signal passes through the A23 Lowband Coupler/Detector to the A30 Modulation Filter.

Digital

In addition to providing the analog functionality described above, the A8 Output assembly used in vector models contains an I/Q modulator that is driven with signals from the A13 I/Q Multiplexer to provide I/Q modulation <3.2 GHz. When digital modulation is not selected, the I/Q modulator is bypassed.

A12 <3.2 GHz Fast Pulse Modulator (Option UNW)

Option UNW is a hardware/firmware (license key) option that provides improved pulse performance (see the data sheet for specific pulse width performance). A firmware license key is required to turn Option UNW on; below 3.2 GHz additional hardware is also required. The additional hardware for this option is installed in the lowband path between the A8 Output and the A23 Lowband Coupler Detector. The pulse drive signal is electrically switched from the A8 Output to the UNW hardware, and the pulse diode on the A8 Output is biased on, allowing the RF signal to pass through. The pulse shaper circuitry on the A11 Pulse Modulator needs to be set using a license key to provide narrower pulse widths.

A23 Lowband Coupler/Detector, A24 Highband Coupler, and A25 High Band Detector

The coupler couples off a portion of the RF signal which is then detected and used to monitor the RF output power level. The detector converts the coupled RF signal to a dc voltage that is routed to the A10 ALC, where it is compared to a reference voltage and integrated. The integrated output provides the ALC diode bias.

The A23 Lowband Coupler/Detector is used for frequencies ≤ 2 GHz; the A24 Highband Coupler and A25 Highband Detector are used for frequencies > 2 GHz.

In 20 GHz analog and vector instruments, the A24 Highband Coupler and A25 Highband Detector are located after the A30 Modulation Filter. In 40 GHz analog models, the A24 Highband Coupler and A25 Highband Detector are located after the A27 40 GHz Doubler. In models with output frequencies above 40 GHz, the A24 Highband Coupler and A25 Highband Detector are located after the A36 Quadraplier. In vector models with output frequencies above 20 GHz, the A24 Highband Coupler and A25 Highband Detector are located after the A37 Upconverter. The output of the A24 Coupler is routed to either the attenuator (the attenuator is optional for the analog models and standard for the vector models) or the RF output connector.

The A23 Lowband Coupler/Detector is located at the end of the lowband path, prior to the A30 Modulation Filter, where the low band signal is switched into the high band path. Because the A23 Lowband Coupler/Detector is a single unit, the coupler and detector must be replaced together; the A24 Highband Coupler and A25 Highband Detector are separate units that you can replace independently.

A27 40 GHz Doubler (Analog 40 GHz Models and Vector 44 GHz Models)

The 40 GHz Doubler generates frequencies from 20 to 40 GHz. The doubler has two inputs from the A30 Modulation Filter. One input routes frequencies ≤ 20 GHz to a bypass switch, and the other input routes 10 to 20 GHz signals to the 40 GHz Doubler. After doubling, band pass filters eliminate unwanted harmonics. In analog models, the 40 GHz output is routed to the A24 Highband Coupler and A25 High Band Detector. In vector models, the A27 40 GHz Doubler output is routed to the LO input of the A37 Upconverter.

A29 20 GHz Doubler

The A29 20 GHz Doubler provides RF signals to the:

- synthesis loop (described on [page 131](#))
- low (< 3.2 GHz) band RF path (to the A6 Frac-N)
- high (> 3.2 GHz) band RF path

Frequencies 3.2 to 10 GHz pass through the A29 20 GHz Doubler. Frequencies 10 to 20 GHz are generated in the doubler by doubling the 5–10 GHz YO signal. Frequencies > 3.2 GHz are routed from the A29 20 GHz Doubler to the A30 Modulation Filter (in analog models) or to the 3 to 20 GHz I/Q Modulator (in vector models).

A30 Modulation Filter

One function of the A30 Modulation Filter is to switch the highband and lowband signals into a common path. Therefore the output frequency range of the A30 Modulation Filter is 100 kHz to 20 GHz. For frequencies > 3.2 GHz, the A30 Modulation Filter provides amplitude and pulse modulation circuitry, power level control, and filtering. Frequencies < 3.2 GHz are simply switched through the A30 Modulation Filter and are not filtered or modulated by any circuitry in the A30 Modulation Filter.

The highband ALC diode within the A30 Modulation Filter provides level control and amplitude modulation. With no bias applied to the ALC diode, output power is at the maximum power level. In pulse operation, the pulse diode must be biased on for the RF signal to pass through the pulse modulation circuitry.

In 20 GHz analog signal generators, the A30 Modulation Filter output is routed to the A24 Highband Coupler and A25 Highband Detector. In 40 GHz analog instruments, two outputs from the A30 Modulation Filter are routed to the A27 40 GHz Doubler, one input for frequencies ≤ 20 GHz to a bypass switch and one to the 40 GHz Doubler circuit. In signal generators with output frequencies above 40 GHz, the A27 40 GHz doubler is replaced with the A36 Quadraplier. In these instruments two A30 Modulator outputs go to the A36 Quadraplier. One of the A30 Modulator outputs is connected to the A36 Quadraplier bypass circuit and the other to the doubler circuit.

A35 3–20 GHz I/Q Modulator (Vector Models Only)

The A35 3–20 GHz I/Q Modulator adds I/Q information to the RF signal. In 20 GHz models, the A35 3–20 GHz I/Q Modulator is installed between the A28 20 GHz Doubler and the A30 Mod Filter. In models with output frequencies above 20 GHz, the A35 3–20 GHz I/Q Modulator is installed after the A28 20 GHz Doubler with one output (11.4–19 GHz) routed to the A27 40 GHz Doubler and the other output routed to the A37 Upconverter. The A35 3–20 GHz I/Q Modulator provides the 90° delay circuitry required for I/Q modulation. The I and Q inputs to the A35 3–20 GHz I/Q Modulator are from the A13 I/Q Multiplexer. The A13 I/Q Multiplexer receives inputs from the External I/Q Mod inputs and, if installed, the Option 601/602 Baseband Generator.

A36 Quadraplier (Analog Models > 40 GHz)

The A36 Quadraplier is installed after the A25 20 GHz Modulator and before the A24 High Band Detector Coupler. The A36 Quadraplier provides an input to a through path for signals from 250 kHz to 20 GHz and an input a doubler path for frequencies >20 GHz. The doubler path contains 2 doublers, on to generator frequencies up to 40 GHz, and a second to generate frequencies above 40 GHz. For frequencies > 20 GHz to \leq 40 GHz, the doubler output is switched to a path containing ALC and pulse modulation circuitry and then to the A36 Quadraplier's output. For frequencies > 40 GHz, the 20 to 40 GHz doubler output is switched to the second doubler and another ALC and pulse modulation control circuit before going to the A36 Quadraplier's output.

Two prelevel detectors in the A36 Quadraplier provide feedback to the A30 Modulation Filter/ALC modulator to control the power into the A36 Quadraplier. One pre-level detector is located in the 20 GHz to 40 GHz path, and the other is located in the > 40 GHz path. The ALC modulator drive signal from the A10 ALC board is routed to the A36 Quadraplier to control the power level and provide AM modulation. Depending on the frequency, the ALC modulation drive is switched to the A30 Modulation Filter, the A36 Quadraplier's 20 to 40 GHz path, or the A36 Quadraplier > 40 GHz path.

A37 44 GHz Upconverter (Vector Models > 20 GHz)

The A37 Upconverter's main function is to be a mixer and to generate frequencies > 20 GHz. For frequencies less than 20 GHz, the A35 3–20 GHz I/Q Modulator output is routed through the A37 Upconverter to the A30 3–20 GHz Modulation Filter, then through the upconverter to its output.

For frequencies > 20 GHz, the output of the A35 3–20 GHz IQ Modulator is routed to the A37 Upconverter and switched to the IF (IQ) input of the mixer. The 40 GHz Doubler output is routed to the A37 Upconverter and connected to the LO input of the mixer. The upconverter's mixer LO frequency is always four times the IF frequency. The desired RF output signal from the mixer will be either the sum frequency (LO+IF) or the difference frequency (LO-IF). For frequencies between 20 and 28.5 GHz the difference frequency is used. Without correction the difference frequency mixing products will invert IQ, FM, and phase modulation. For example, an increasing frequency FM mixer input signal will produce a decreasing frequency FM mixer output signal. When operating in the > 20 GHz and < 28.5 GHz frequency range, the PSG automatically corrects internal and external IQ, FM, and phase modulation signals. However, the PSG does not correct I and Q input signals from the rear panel for Option 015 (Wideband IQ) inputs. To maintain the correct phase relationships in this frequency band, the I and Q wideband inputs at the signal generator's rear panel must be reversed.

NOTE Instruments with Option 015 route the rear panel wideband IQ inputs directly to the IQ modulator. Swap the I and Q signals when using the rear panel wideband IQ inputs at RF > 20 GHz and < 28.5 GHz.

ALC Loop

The ALC loop maintains power level control and power level accuracy. Level accuracy is achieved by converting a portion of the RF signal to a dc voltage, comparing the measured dc voltage to a reference dc voltage, integrating the difference, and using the integrated output to drive the ALC modulation diode. Level control is achieved by adjusting the reference voltage.

The A23 Lowband Coupler/Detector, A24 Highband Coupler and A25 Highband Detector couple off the RF signal and convert it to a dc voltage. Because the coupled signal is a known ratio of the RF output power, it can be used to control the RF output level. On the A10 ALC assembly, the dc is compared to a reference voltage and integrated. The integrated voltage is used to drive the modulator diodes on the A8 Output, A30 Modulation Filter, A36 Quadraplier, and A37 44 GHz Upconverter. Temperature-sensing circuits maintain level correction over the specified temperature range. In sweep mode, additional compensation is applied to the ALC from the A9 YIG Driver to maintain power flatness during sweep.

A10 ALC

The A10 ALC assembly provides circuitry for level control and amplitude modulation. In **ALC On** mode (closed-loop operation), the output signal level is continually monitored and used to adjust the modulator diode output to produce the desired RF output level. In **ALC On** mode, the A10 ALC integrates the difference between the detected voltage and the reference voltage to adjust the modulator diode drive until both voltages agree. The A23 Lowband Coupler/Detector, A24 Highband Coupler, and A25 Highband Detector provide the feedback (detected DC) voltage to the A10 ALC. On the A10 ALC, the reference voltage is generated by DACs that are controlled by the CPU. The DAC's output voltage is calibrated to the RF output power level.

In **ALC Off** mode (open-loop operation), the feedback path (the RF detected voltage path) is opened, and only the reference voltage is used to set the output power level. With the modulator reference level set to a fixed drive level, and without the output level being monitored, the RF output level can vary from the set power level. In open-loop operation, the power level can also drift over time due to changes in temperature.

In **external leveling** operation, the internal detectors are replaced with an external detector, so the level control voltage is provided by the external detector. The external detector must be a negative detector to provide the

correct polarity for the A10 ALC. In standard instruments, the external leveling operating range is option-dependent, but is either -20 dBm or -15 dBm to maximum power.

Level accuracy is a function of the detector and instrument calibration. Because the instrument is calibrated with internal detectors, external level accuracy depends on the difference in characteristics between the internal and external detectors.

When **internally** leveled, the ALC circuit is temperature compensated to improve level accuracy over the specified temperature range. Temperature compensation for the A25 Highband Detector consists of a temperature sensing circuit on the A24 Highband Coupler. A resistor pack calibrates the A25 Highband Detector; if the A25 Highband Detector is replaced, a new resistor pack is provided with the new detector, and must be installed on the A24 Highband Coupler. Although rare, unstable level performance above 2 GHz can result from poorly soldered resistors on the resistor pack, or with other components in the temperature compensation circuit.

The A23 Lowband Coupler Detector temperature correction circuit is inside the A23 Lowband Coupler Detector package. Because the lowband detector and coupler are in one package, they cannot be replaced independently.

Modulation (Option UNT-AM, FM, Φ M, UNU-Standard Pulse, and UNW-Fast Pulse)

Modulation features apply only to certain options of signal generators. The A11 Pulse/Analog Modulation Generator provides modulation signals for AM, FM, pulse, and phase, and SYNC OUT and VIDEO OUT. For phase synchronization and modulation accuracy, a dual function generator on the A11 Pulse/Analog Modulation Generator is tied to the 10 MHz reference from A7 Reference. Pulse Input, EXT1, and EXT2 provide external modulation input connections. A front panel low frequency output connector (LF Output) can be selected to output the signal generated by the A11 Pulse/Analog Modulation Generator and can be used to drive other instruments.

EXT 1 and EXT 2 inputs contain modulation drive level detection circuits that generate error messages if the signal applied to the input is too small or too large. The input impedance of EXT 1 and EXT 2 can be set for 50 or 600 ohms, and can be configured for dc or ac coupling.

AM (Option UNT)

The AM signal from the A11 Pulse/Analog Modulation Generator is routed to the A10 ALC, where it is summed with the ALC reference voltage where it is used to drive the A30 Modulation Filter, A36 Quadraplier, A37 44 GHz Upconverter, and A8 Output ALC diodes.

FM/ Φ M (Option UNT)

The FM/ Φ M signal is routed from the A11 Modulation Generator to the A6 Frac-N. On the A6 Frac-N:

Troubleshooting

RF Path Description (Frequency Generation, Level Control, and Modulation)

- FM rates < 4 kHz are applied to the pre-scale control circuit and the A6 Frac-N VCO. This generates a change in the pre-scaled drive (feedback from the VCO) to the VCO's phase detector, causing a VCO frequency change.
- FM rates 4 kHz to 100 kHz are applied only to the A6 Frac-N VCO.
- FM rates >100 kHz are routed from the A6 Frac-N to the A9 YIG Driver and applied to the FM coil in the YIG Oscillator.
- For phase modulation, the FM drive signal is routed through an LCR circuit. Other than the LCR circuit, Φ M signals are routed the same as FM signals.

Pulse (Options UNU and UNW)

Pulse modulation signals from the A11 Pulse/Analog Modulation Generator depends on model and option can be routed directly to the A8 Output and the A30 Modulation Filter or A12 Pulse Modulation (UNW) pulse diodes. Pulse diodes must be biased on to pass RF signals. Circuitry on the A8 Output, A30 Modulation Filter, A36 Quadraplier, and A37 44 GHz Upconverter keep the pulse diodes turned on in instruments that do not have modulation capability. Because ALC bandwidth is limited, the ALC circuit can only level pulse widths > 1 microsecond. To level pulse widths < 1 microsecond, use search mode. Search mode calibration sequencing is as follows:

- 1. Modulation is turned off.**
- 2. The ALC feedback loop is closed and the RF power leveled.**
- 3. The ALC feedback loop is opened and the integrated output voltage used to drive the ALC diodes is maintained at the level determined during closed loop operation (step 2).**

Changes in power level, frequency, or pulse settings cause the signal generator to repeat the search mode leveling procedure and determine a new ALC diode drive level. Because drift in that leveling circuit can occur over time in open-loop operation, it is not recommended to stay in search mode for extended periods of time without closing the loop and refreshing the ALC diode drive voltage.

Digital Modulation

Digital modulation is produced using portions of the following major assemblies:

- A8 Output
- A13 I/Q Multiplexer
- A14 Baseband Generator (Option 601/602)
- A35 I/Q Modulator

Together, these assemblies generate and route the baseband signals to the I/Q modulators located on the A8 Output and the A35 I/Q Modulator. The A8 Output modulates carrier signals from 250 kHz to 3.2 GHz, while the A35 I/Q Modulator modulates carrier signals from 3.2 to 20 GHz. The A14 Baseband Generator (Option 601/602) comprises data generation, burst control, and symbol building circuitry. The output section of the A14 Baseband Generator consists of two 16-bit DACs: one for the I signal and one for the Q signal. The data produced from these I/Q signals is converted to analog, amplified, and filtered before being routed to the A13 I/Q Multiplexer. The I/Q signals are routed from the A13 I/Q Multiplexer to the I/Q modulators located on the A8 Output and the A35 I/Q Modulator. These I/Q signals modulate the main RF signal.

A13 I/Q Multiplexer

The A13 I/Q Multiplexer receives I/Q input signals from the A14 Baseband Generator, external I/Q input signals from the front panel, and I/Q sense feedback signals from the I/Q modulators on the A8 Output and A35 I/Q Modulator. The A13 I/Q Multiplexer inverts and routes the I and Q signals to the rear panel, where these signals can be used to modulate external equipment. The A13 I/Q Multiplexer also routes the main internal I and Q modulating signal into the I/Q modulators on the A8 Output and A35 I/Q Modulator, which are used to modulate the main RF output.

The A13 I/Q Multiplexer has two identical paths in which to switch incoming I/Q signals. Each path has individual gain control, and can be switched to a summing node. The output of the summing node can be switched to the EXT outputs (through additional gain control circuitry), and/or simultaneously to the A8 Output and A35 I/Q Modulator.

The EXT IN I and EXT IN Q signals enter the A13 I/Q Multiplexer, and can be switched into a 50 or 600 ohm input impedance.

An internal calibration source supplies the levels required to perform independent self tests. This enables the firmware to check the A13 I/Q Multiplexer by setting known levels and reading the various nodes without actually needing an I/Q signal.

An Offset Sense signal that comes in from the I/Q Modulators on the A8 Output is used to adjust for offsets between the I and Q signals. The Offset Sense signal is compared to the I/Q signal output, and the result is used to control the amplitude; the feedback signal minimizes quadrature and gain errors.

A14 Baseband Generator (Option 601/602)

The A14 Baseband Generator may be used as a dual arbitrary waveform generator, a real time I/Q baseband generator, a noise generator, or a multitone generator. Customer-supplied waveforms can be downloaded into the waveform memory to generate customized formats.

The I/Q bandwidth is 80 MHz for internally generated signals, and 160 MHz for externally generated I/Q signals. The A14 Baseband Generator can generate symbol rates of up to 6.25 Msymbol/sec, and has 8 Msamples (Option 601) and 64 Msamples (Option 602) of waveform memory.

Data is sequenced from waveform memory by the field programmable gate array block (A1–FPGA), passed on to the format builder block (A2–FPGA/Modulator/Filter), and finally to the output section. I and Q DACs at the output convert the digital waveform data to analog. The I and Q output DACs are driven by a sample clock generated by an on-board VCO. The VCO has a frequency range of 200 to 400 MHz. A 10 MHz reference signal from the A7 Reference (or an external 10 MHz reference) can be used to phase-lock the sample clock signal of the DACs.

The Burst Pulse signal from the A14 Baseband Generator goes to the A11 Pulse/Analog Modulation Generator, and is used to drive the pulse modulators on the A8 Output and A30 Modulation Filter. The Burst Pulse signal is used by the digital modulation formats to synchronize the main RF path and ensure maximum on/off level ratio.

The I and Q output signals are the primary signals out of the A14 Baseband Generator. They are the digital modulation signals that go to the A13 I/Q Multiplexer, and are then routed to the I/Q modulators on the A8 Output and A35 I/Q Modulator.

Approximate Device Gains and Losses

You can troubleshoot assemblies in the RF path by measuring gains and losses and comparing them to **Table 1-28**, below. See **“Troubleshooting RF Power Levels” on page 106** for more information.

Table 1-28 **Approximate Device Gains and Losses**

Item #	Device	Gain/Loss	Value (dB)	Analog Instruments	Vector Instruments
1	A8 Output				
	non-1EA/1EU	N/A	> 17	X	X
	1EA/1EU	N/A	> 20		
2	A12 Opt 1E6 Pulse Mod.	Loss	< 3	X	X
3	A23 Lowband Coupler	Loss	< 3	X	X
4	A28 YO Output	N/A	> 11	X	X
5	A29 20 GHz Doubler				
	J1 to J2	Gain	> 1	X	X
	J1 to J3 and J4	Loss	< 18		

Table 1-28 Approximate Device Gains and Losses (Continued)

Item #	Device	Gain/Loss	Value (dB)	Analog Instruments	Vector Instruments
6	A35 3–20 GHz I/Q Mod. Bypass mode, J5 to J1 3.2 to 12.8 GHz 12.8 to 20 GHz	Gain Loss	> 0 < 2		X
7	A30 Modulator Filter J1 to J2 (non-1EA/1EU) J1 to J2 (1EA/1EU) J1 to J4 (non-1EA/1EU) J1 to J4 (1EA/1EU) J3 to J4	Gain Gain Gain Gain Loss	> 0 > 8 > 1 > 9 < 3	X	X
8	A27 40 GHz Doubler J1 to J2 (> 20 GHz) J3 to J2 (< 3.2 GHz) J3 to J2 (3.2 to 20 GHz)	Loss	< 8 < 1 < 2.5	X	
9	A24 Highband Coupler < 3.2 GHz 2–20 GHz > 20 GHz	Loss	< 2.5 < 0.5 < 2.5	X	X
10	AT1 (0 dB step)	Loss	< 2.5	X	X
11	A36 Quadraplier	N/A see Troubleshooting Unlevels		X	
12	A37 Upconverter 3.2–12.8 GHz, J1 to J2 12.8–20 GHz, J1 to J2 250 KHz–20 GHz, J2 to J4 20 GHz, J1 to J4, J1@ <-10.5 dBm 40 GHz, J1 to J4, J1@ <-8.5 dBm 44 GHz, J1 to J4, J1@ <-5 dBm	Loss Gain	<3 <4 <2.5 >21 >21 >18		X
13	A38 Low Band Switch Filter	Loss	<8.5	X	X

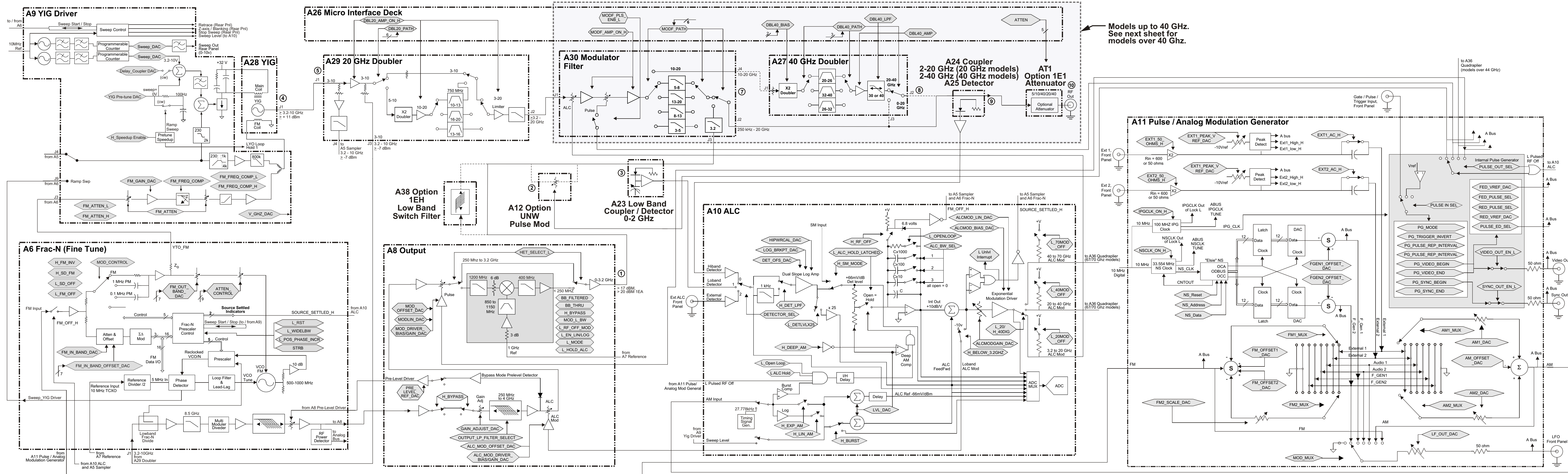

Models up to 40 GHz.
See next sheet for models over 40 GHz.

Block Diagram for the Analog RF Path, Service Guide E8251-90359

A26 Micro Interface Deck

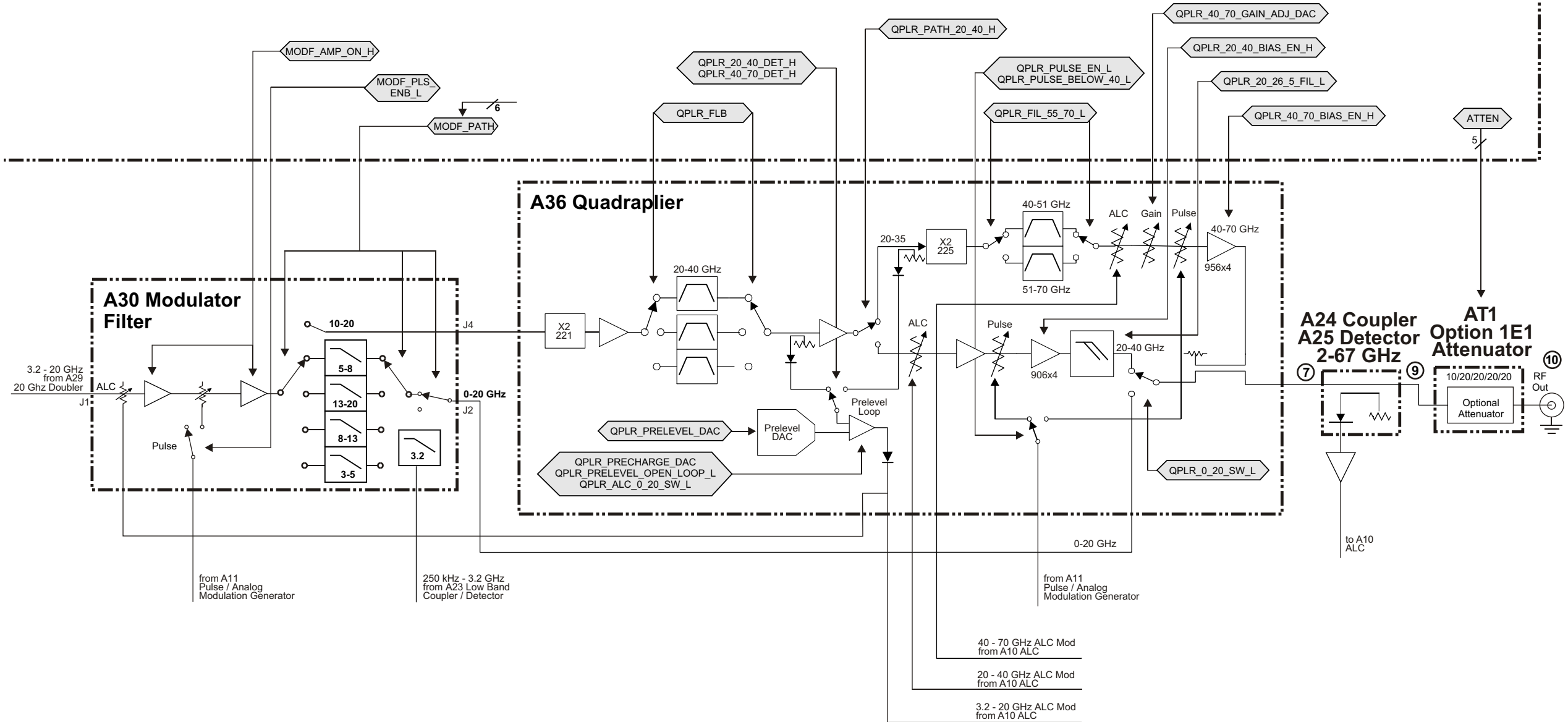

Quadrupler Block for the E8257D PSG Analog RF Path
(Analog Models Over 40 GHz), Service Guide E8251-90359

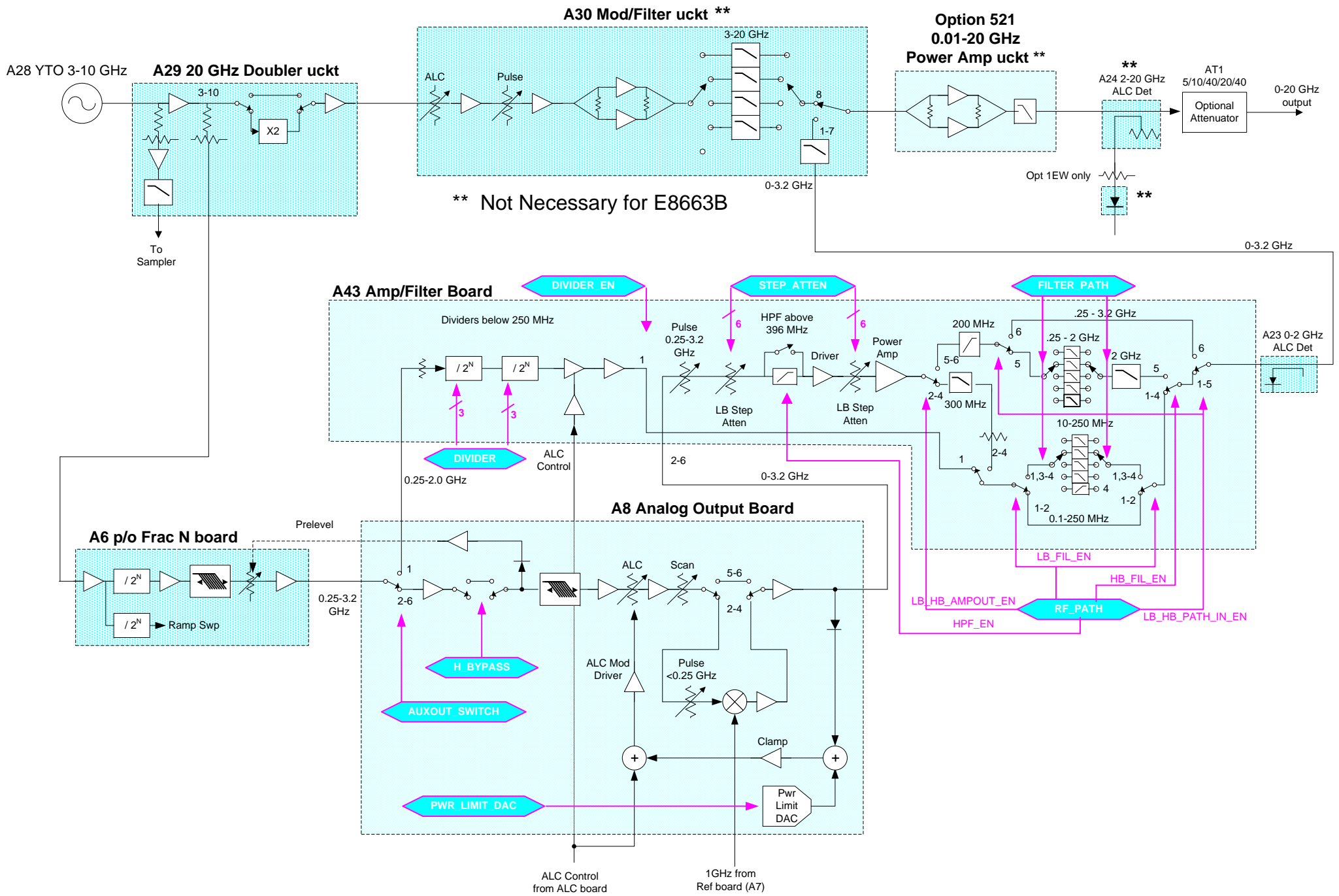

Block Diagram for the Analog Low Band RF Path, Service Guide E8251-90359
(prefix ≥US4928/MY4928/SG4928)

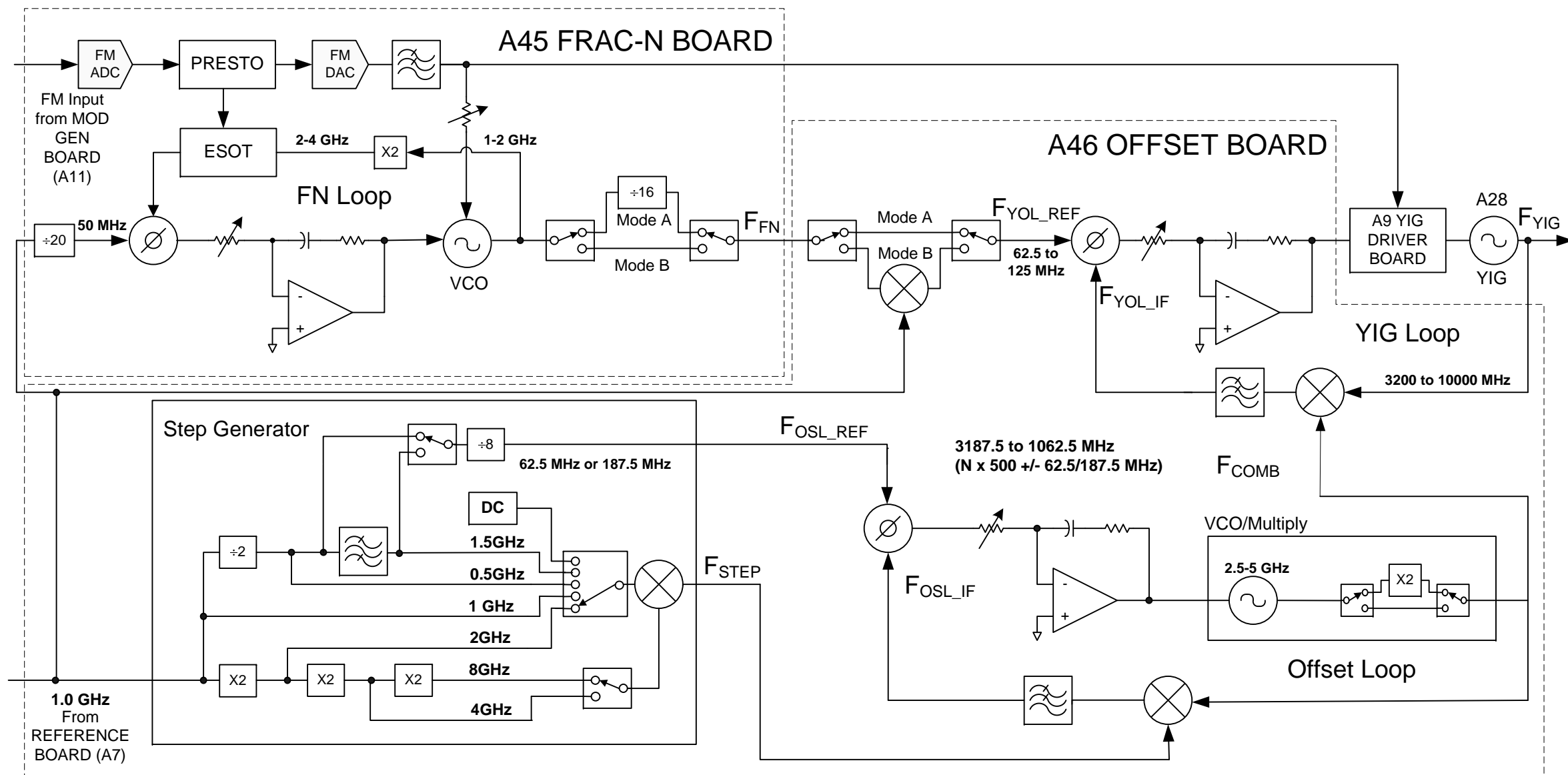

Block Diagram for Option UNY, Service Guide E8251-90359
(prefix \geq US5042/MY5042/SG5042)

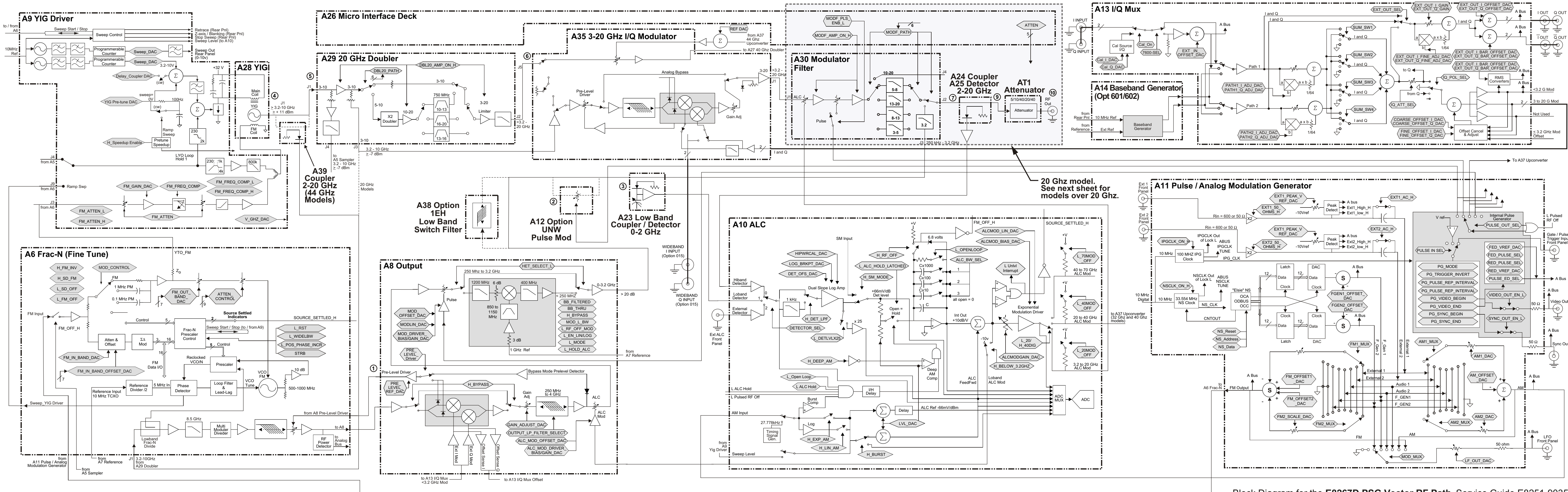

20 GHz model.
See next sheet for
models over 20 GHz.

Block Diagram for the E8267D PSG Vector RF Path, Service Guide E8251-90359

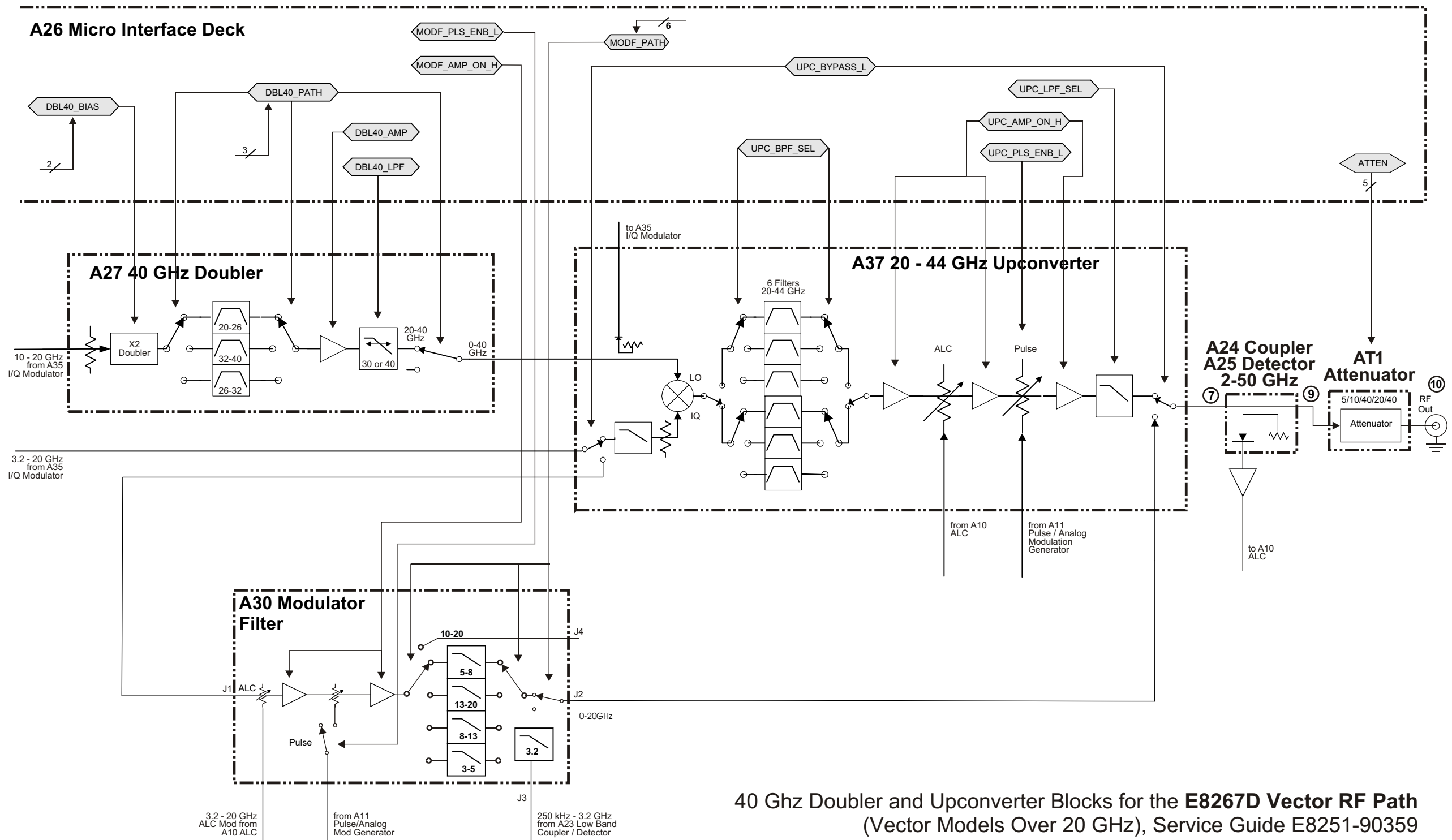

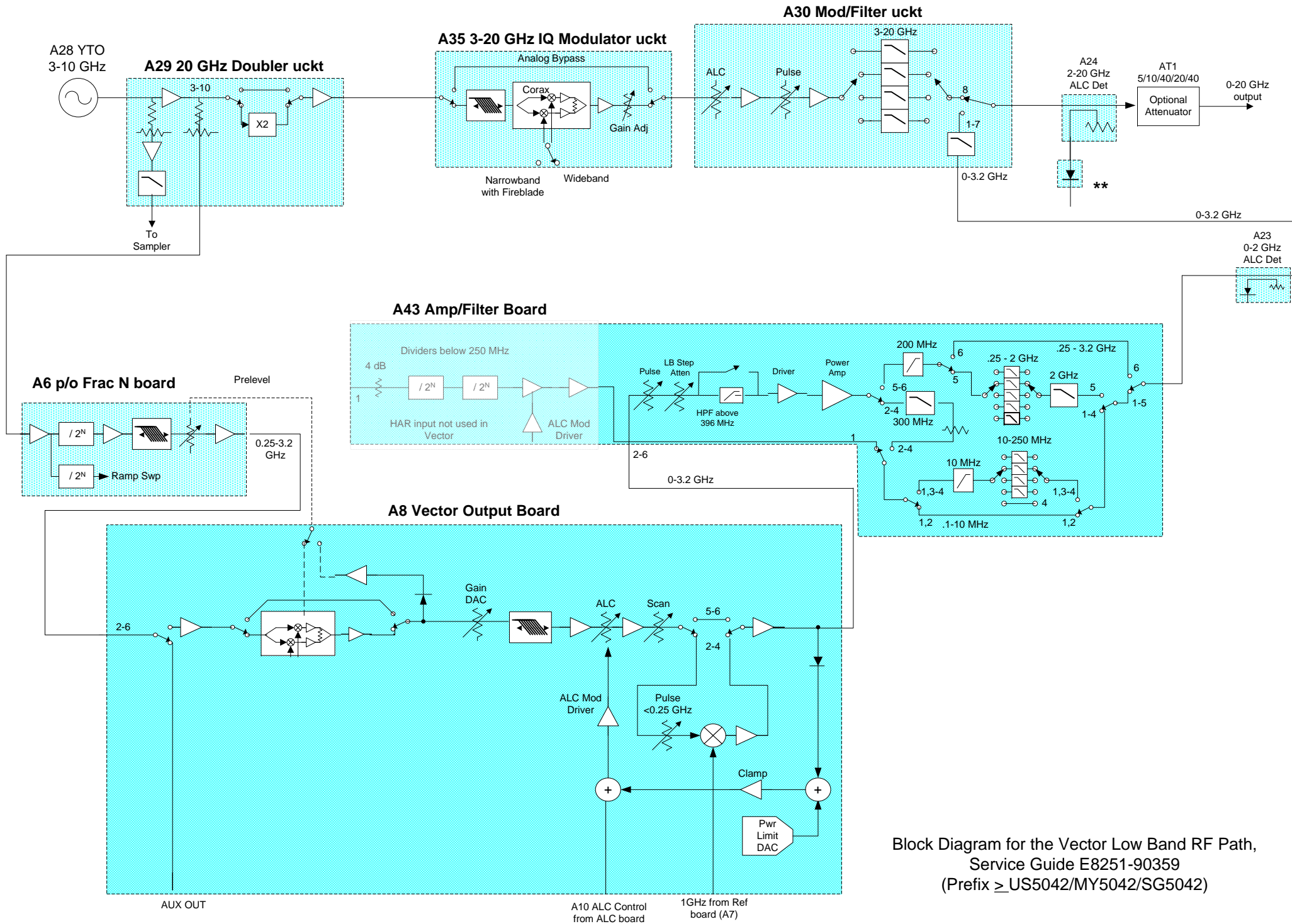

Block Diagram for the Vector Low Band RF Path,
Service Guide E8251-90359
(Prefix ≥ US5042/MY5042/SG5042)

Self-Test Overview

A group of tests (self-tests) are embedded in the signal generator's firmware that can evaluate the condition of the circuitry on many of the assemblies. Self-tests check hardware performance under controlled conditions, and compare test results to predetermine limits. If the results fall within the limits the signal generator passes. If the results of one or more tests fall outside the limits, the self-test routine evaluates the failures and reports the most independent failure.

Because self-tests are designed to check signal generator **hardware**, the signal generator does not need to be calibrated for self-tests to pass. Self-tests are designed with the philosophy that it is better to pass a defective signal generator than to fail a good one; some failures will pass, rather than be detected and reported. If the signal generator powers on and self-tests can be run, always start troubleshooting by running self-tests and resolving reported problems.

How self-test works:

1. When the signal generator is tested at the factory, self-test limits are loaded into the A18 CPU memory from devices on each assembly, or from fixed files. Most assemblies contain limit information, while microcircuit limits must be loaded.
2. When the program runs, latches and DACs are set to a known state.
3. An analog mux routes the detected dc signal from the selected test node to the A18 CPU.
4. The A18 CPU compares the detected dc level to the test limit. If the detected value is within the limits, the A18 CPU reports a pass.
5. If one or more detected values fall outside the limits, the most independent failure is determined and reported.

Independent failures

An example best illustrates independent failures; in this example, there are three assemblies in a series: A1, A2, and A3. The output of A1 is the input for A2, and the output of A2 is the input for A3. If the output of A1 is bad, A2 and A3 outputs are also bad. If the output of A2 is bad, the output of A3 is also bad. A file in the signal generator contains this dependency knowledge for the signal generator to use to identify the most independent failure. If A1, A2, and A3 self-tests all fail, the signal generator reports A1 as the most independent failure. If A1 passes but A2 and A3 fail, self-test reports A2 as the most independent failure. If A2 passes and A3 fails, self-test reports A3 as the most independent failure. If two independent failures occur, self-test reports only one failure at a time and reports the second failure after the first reported failure is repaired.

Troubleshooting
Self-Test Overview

Troubleshooting procedures in this chapter are based on the most independent failure, and no lower level information is needed. Although not needed for troubleshooting, the self-test overhead does provide features to view lower level detailed information about the subroutines, and select specific routines to run. These features include:

- Select/Deselect Test
- Select/Deselect All
- View Details
- When View Details is selected, the highlighted test's measured value, lower, and upper limits are displayed.
- Run Highlighted Tests
- Run Selected Tests

Contacting Keysight Technologies

If you have a problem with your signal generator, contact your nearest sales and service office (refer to [page 1-169](#)). When calling, please be prepared with the following information:

Model Number: _____ **Serial Number:** _____
Firmware Revision: _____ **Installed Options:** _____
Firmware Date: _____ _____

If you are having problems with an option upgrade

What option(s) are you trying to install: _____

Describe the problem: _____

If you suspect a hardware problem

Self-test results:

Pass/Fail: _____

Reported self-test failure: _____

Error message reported on the front panel:

Unlock: _____

Unleveled: _____

Other _____

Did the instrument fail when it arrived, has it been degrading over time, or was it working for some time and then failed?

Describe the problem: _____

What action has been taken: _____

If you are having a problem with performance tests or adjustments

Software revision: _____

Troubleshooting
Contacting Keysight Technologies

Name of adjustment or performance
test: _____

Reported software
message: _____

Describe the problem: _____

If you are having a problem with an application

Describe what you want to do: _____

Describe the problem: _____

Keysight Sales and Service Offices

Assistance with test and measurements needs, and information on finding a local Keysight office is available on the Web at:

<http://www.keysight.com/find/assist>

You can also purchase E8257D/67D PSG accessories or documentation items on the web at:

<http://www.keysight.com/find/psg>

If you do not have access to the Internet, please contact your field engineer.

NOTE

In any correspondence or telephone conversation, refer to the signal generator by its model number and full serial number. With this information, the Keysight representative can determine whether your unit is still within its warranty period.

Packaging a Signal Generator for Return

1. Use the original packaging materials or a strong shipping container that is made of double-walled, corrugated cardboard with 159 kg (350 lb.) bursting strength. The carton must be both large enough and strong enough to accommodate the signal generator and allow at least 3 to 4 inches on all sides of the signal generator for packing material.

CAUTION

Signal generator damage can result from using packaging materials other than those specified. Never use styrene pellets, in any shape, as packaging materials. They do not adequately cushion the instrument or prevent it from shifting in the carton. Styrene pellets cause equipment damage by generating static electricity and by lodging in the signal generator fan.

2. Surround the instrument with at least 3 to 4 inches of packing material, or enough to prevent the instrument from moving in the carton. If packing foam is not available, the best alternative is SD-240 Air Cap™ from Sealed Air Corporation (Hayward, CA 94545). Air Cap looks like a pink plastic sheet covered with 1.250 inch air-filled bubbles. Use the Air Cap to reduce static electricity. Wrap the instrument several times in the material to both protect the instrument and prevent it from moving in the carton.
3. Seal the shipping container securely with strong, nylon adhesive tape.
4. Mark the shipping container “FRAGILE, HANDLE WITH CARE” to ensure careful handling.
5. Retain copies of all shipping papers.

Troubleshooting
Contacting Keysight Technologies

2 Replaceable Parts

Ordering Information

To order a part, do the following:

- 1. Determine the part number.**
- 2. Determine the quantity required.**
- 3. Mail this information to the nearest Keysight Technologies office or, in the U.S., call the hot-line number listed in the following section.**

To order a part not listed in the replaceable parts lists, mail the following information to the nearest Keysight Technologies office or, in the United States, call the hot-line number listed in the following section.

- 1. the instrument model number**
- 2. the serial number and options, if any (see rear panel)**
- 3. a description of the part**
- 4. a description of the part's function**
- 5. the quantity required**

Order Parts Fast

When you have gathered the information required to place an order, go to the Keysight Technologies Technical Support website:

<http://www.keysight.com/find/techsupport>

Frequency, Hardware, and Personality Options

This section lists the options available with an Keysight E8257D/67D, E8663D PSG signal generator.

Table 2-1

Frequency Options	
503	100 kHz to 3.2 GHz frequency range (E8663D Only)
509	100 kHz to 9 GHz frequency range (E8663D Only)
520	250 kHz to 20 GHz frequency range (E8257D/67D Only)
521	10 MHz to 20 GHz frequency range (E8257D Only)
532	250 kHz to 32 GHz frequency range (E8257D/67D Only)
540	250 kHz to 40 GHz frequency range (E8257D Only)
544	250 kHz to 44 GHz frequency range (E8267D Only)
550	250 kHz to 50 GHz frequency range (E8257D Only)
567	250 kHz to 67/70 GHz frequency range (E8257D Only)

Table 2-2

Hardware Options	
1E1	Adds output step attenuator for extended range to -135dBm (E8257D and E8663D Only)
1EA (Discontinued)	Adds high RF output power $+20\text{dBm}$ at 20 GHz, $+14\text{ dBm}$ at 40 GHz (E8257D Only)
1ED	Specifies Type-N RF output connector (20 GHz models only)
1EH	Adds improved harmonics
1EM	Moves all front panel connectors to rear panel
1EU	High output power (E8257D and E8663D)
1SM	Adds scan modulation (E8257D and E8663D)
UNR (Discontinued)/UNX	Adds enhanced close-in phase noise
UNT	Adds AM/FM modulation
UNW	Adds fast pulse $< 3.2\text{ GHz}$
UNY	Adds enhanced ultra-low phase noise
003	Adds digital outputs to DSIM (E8267D Only)
004	Adds digital inputs to DSIM (E8267D Only)
005 (Discontinued)	Adds 6 GB hard drive (Option 601/602 required) (E8267D Only)
007	Adds analog ramp sweep

Replaceable Parts
Frequency, Hardware, and Personality Options

Table 2-2

Hardware Options	
008	Adds 8 GB flash drive (E8257D and E8663D Only)
009	Adds 8 GB flash drive (Option 601/602 required) (E8267D Only)
015 (Discontinued)	Adds wideband (single-ended) external I/Q input ports (1GHz) (E8267D Only)
016	Adds wideband (differential) external I/Q input ports (1GHz) (E8267D Only)
601 (Discontinued)	Adds internal baseband generator with 8 Mega sample memory (E8267D Only)
602	Adds internal baseband generator with 64 Mega sample memory (E8267D Only)

Assemblies

Table 2-3

Assembly	E8257D and E8663D		E8267D	
	Part Number	Page Number	Part Number	Page Number
A1 Keyboard	E8251-63664	2-9	E8251-63664	2-9
A2 Display				
for instruments with serial prefix < US/MY5XXX3XXX	E8251-67367	2-9	E8251-67367	2-9
for instruments with serial prefix > US/MY5XXX3XXX	2090-1053	2-9	2090-1053	2-9
A2DS1 Display Backlight (used with instruments with serial prefix < US/MY5XXX3XXX only)	1513-5204	2-9	1513-5204	2-9
A3 Power Switch	E8251-63662	2-9	E8251-63662	2-9
A4 Inverter (used with instruments with serial prefix < US/MY5XXX3XXX only)	0950-3757	2-9	0950-3758	2-9
A5 Sampler	E8251-60646 ^a	2-11, 2-12, and 2-13	E8251-60646 ^a	2-14 and 2-15
A6 Frac-N	E8251-60647 ^b	2-11, 2-12, and 2-13	E8251-60647 ^b	2-14 and 2-15
A7 Reference (for instruments with serial prefixes < US4805/MY4805)	E8251-60073	2-11, 2-12, and 2-13	E8251-60073	2-14 and 2-15
or A7 Reference (Option UNR)	E8251-60048	2-11, 2-12, and 2-13	E8251-60048	2-14 and 2-15
or A7 Reference (Option UNX and instruments with serial prefixes > US4805/MY4805)	E8251-60648	2-11, 2-12, and 2-13	E8251-60648	2-14 and 2-15
A8 Output (for instruments with serial prefixes < US4928/MY4928)	E8251-60075 ^c	2-11, 2-12, and 2-13	N/A	
A8 Output (for instruments with serial prefixes > US4928/MY4928)	E8251-60434 ^a	2-11, 2-12, and 2-13	N/A	
A8 Output (for instruments with serial prefixes < US5042/MY5042)	N/A		E8251-60340 ^d	2-14 and 2-15
A8 Output (for instruments with serial prefixes > US5042/MY5042)	N/A		E8251-60435	2-14 and 2-15
A9 YIG Driver	E8251-60666 ^a	2-11, 2-12, and 2-13	E8251-60666 ^a	2-14 and 2-15
A10 ALC	E8251-60668 ^a	2-11, 2-12, and 2-13	E8251-60668 ^a	2-11, 2-12, and 2-13

Replaceable Parts
Assemblies

Table 2-3

Assembly	E8257D and E8663D		E8267D	
A11 Pulse/Analog Modulation Generator	E8251-60655 ^a	2-11, 2-12, and 2-13	E8251-60655 ^a	2-14 and 2-15
A12 Pulse Modulator Board (Option UNW) (E8257D instruments with serial prefixes < US4928/MY4928)	E8251-60064	2-14 and 2-15	E8251-60064	2-14 and 2-15
A12 Pulse Modulator Board (Instruments with Option UNW and HAR) (E8257D instruments with serial prefixes < US4928/MY4928)	E8251-63634	2-14 and 2-15	N/A	
A13 I/Q MUX (For instruments with serial prefixes < US4722/MY4722)	N/A		E8251-60208	2-14 and 2-15
(For instruments with serial prefixes > US4722/MY4722)	N/A		E8251-60669	2-14 and 2-15
A14 Baseband Generator	N/A		E4400-60765	2-14 and 2-15
A17 Baseband Generator Interface	N/A		E8251-60852	2-15
A18 CPU	E8251-60661 ^a	2-11, 2-12, 2-13 and 2-21	E8251-60661 ^a	2-14, 2-15 and 2-21
A18BT1 Lithium Battery	1420-0314	2-21	1420-0314	2-21
A19 Power Supply	0950-5201	2-11, 2-12, and 2-13	0950-5200	2-14 and 2-15
A20 SMI (Source Module Interface)	E8251-63663	2-11, 2-12, and 2-13	E8251-63663	2-14 and 2-15
A21 Rear Panel Interface	E8251-63660	2-19	E8251-63660	2-20
A22 Line Module	5064-5053	2-19	9135-5695	2-20
A23 Lowband Coupler/Detector	E8251-60442	2-11, 2-12, 2-13, and 2-16	E8251-60444	2-14, 2-15, 2-18 and 2-20
A24 20 GHz Highband Coupler (Option 503, 509, and 520)	0955-0148	2-11 and 2-16	0955-0148	2-14 and 2-18
A24 20 GHz Highband Coupler (Option 521)	0955-2025	2-12 and 2-17	N/A	
A24 40 GHz Highband Coupler (Option 540)	0955-1136	2-11 and 2-16	N/A	
A24 50 GHz Highband Coupler (Options 532 and 544)	N/A		0955-1425	2-15 and 2-18

Replaceable Parts
Assemblies

Table 2-3

Assembly	E8257D and E8663D		E8267D	
A24 67 GHz Highband Coupler (Options 550 and 567)	5087-7744	2-13 and 2-17	N/A	
A25 20 GHz Highband Detector (Options 503, 509, 520, and 521)	08360-60326 ^e	2-11, 2-12, 2-16, and 2-17	08360-60326 ^e	2-14 and 2-18
A25 40 GHz Highband Detector (Option 540)	08360-60327 ^e	2-11 and 2-16	N/A	
A25 50 GHz Highband Detector (Options 532 and 544)	N/A		08474-60027 ^e	2-15 and 2-18
A25 67 GHz Highband Detector (Options 550 and 567)	08474-60026 ^e	2-13 and 2-17	N/A	
A25B Highband Detector Bias Board	E8251-63635 ^e	2-11, 2-12, 2-13, 2-16, and 2-17	E8251-63635 ^e	2-14, 2-15 and 2-18
A26 MID (Microwave Interface Deck)	E8251-60658	2-11, 2-12, 2-13, 2-16, and 2-17	E8251-60657	2-14, 2-15 and 2-18
A27 40 GHz Doubler (Options 532, 540 and 544)	5087-7717	2-11 and 2-16	5087-7717	2-15 and 2-18
A28 YIG Oscillator	5087-7739	2-16, 2-17, and 2-19	5087-7739	2-18 and 2-20
A29 20 GHz Doubler	5087-7738	2-19	5087-7738	2-20
A30 Modulation Filter with High Power	5087-7737	2-19	5087-7737	2-20
A31 Motherboard	E8251-60133 ^a	2-19	N/A	
A31 Motherboard	N/A		E8251-60667	2-20
A32 10 MHz Crystal Oscillator (for instruments with serial prefixes > US4805/MY4805)	E8251-60625	2-11, 2-12, and 2-13	E8251-60625	2-14 and 2-15
A32 10 MHz Crystal Oscillator (Option UNX)	E8251-60626	2-11, 2-12 and 2-13	E8251-60626	2-14 and 2-15
A32 10 MHz Crystal Oscillator (Option UNY)	E8251-60798	2-11, 2-12 and 2-13	E8251-60798	2-14 and 2-15
A32 10 MHz Crystal Oscillator (Option UNR – Discontinued)	E8251-60071	2-11, 2-12 and 2-13	E8251-60071	2-14 and 2-15

Replaceable Parts
Assemblies

Table 2-3

Assembly	E8257D and E8663D		E8267D	
	Part Number	Reference	Part Number	Reference
A33 3.5 6 dB PAD (E8257D Option 521 and E8267D Option 520)	08493-60026	2-12 and 2-17	08493-60026	2-14
A33 3.5 10dB PAD (Options 532/544)	N/A		08493-60027	2-15 and 2-18
A34 Internal Hard Drive (Option 005 – Discontinued) (for instruments with serial prefixes < 4829)	N/A		E8251-60115	2-15
A35 3–20 GHz I/Q Modulator (for instruments with serial prefixes < US4722/MY4722)	N/A		5087-7059	2-20
A35 3–20 GHz I/Q Modulator (for instruments with serial prefixes > US4722/MY4722)	N/A		5087-7742	2-20
A36 Quadrupler (Options 550 and 567 only)	5087-7741	2-13 and 2-17	N/A	
A37 Upconverter	N/A		5087-7740	2-15 and 2-18
A38 Lowband Switch Filter (Option 1EH) (For instruments with serial prefixes < US4928/MY4928)	E8251-60305	2-13	E8251-60305	2-14 and 2-15
A39 Directional Sweep Coupler (Options 532 and 544 only)	N/A		0955-0148	2-15 and 2-18
A40 PCA, IDE/Compact Flash Drive E8257D/E8663D: instruments with serial prefixes > US4928/MY4928 E8267D: instruments with serial prefixes > US4829/MY4829	E8251-63640	2-12	E8251-63640	2-14
A41 Compact Flash Door E8257D/E8663D: instruments with serial prefixes > US4928/MY4928 E8267D: instruments with serial prefixes > US4829/MY4829	E8251-60630	2-12	E8251-60630	2-14
A42 20 GHz Power Amp (Option 521 only)	1NB7-8584	2-19	N/A	
A43 Lowband Amp Filter (For instruments with serial prefixes > US5042/MY5042/SG5042 with Options UNX and UNY)	E8251-60633 ^a	2-12	E8257-60098	
A43 Lowband Amp Filter (For instruments with serial prefixes > US5150/MY5150/SG5150 without Options UNX and UNY)	E8257-60098	2-12	E8257-60098	

Replaceable Parts
Assemblies

Table 2-3

Assembly	E8257D and E8663D		E8267D	
A43 Lowband Amp Filter (For instruments with serial prefixes = US4928/MY4928/SG4928)	E8251-60422 ^f	2-12	N/A	
A44 Scan Modulation Bias Adapter (E8663D and Option E8257D-520)	E8251-63656	not shown	N/A	
A45 Frac-N (used with Offset Loop Option UNY)	E8251-60437	2-11, 2-12, and 2-13	E8251-60437	
A46 Offset Loop (Option UNY)	E8251-60438	2-11, 2-12, and 2-13	E8251-60438	
AT1 115 dB Mechanical Attenuator (Options 503, 509, 520, 521, 532, 540, and 544)	33328-60006	2-11, 2-12, 2-16, 2-17 and 2-19	33328-60007	2-14, 2-15, and 2-20
AT1 90 dB Mechanical Attenuator (Options 550 and 567)	84908-60006	2-13 and 2-17	N/A	
B1 Fan	3160-4121	2-11, 2-12, 2-13, and 2-19	3160-4121	2-14, 2-15, and 2-20
RF Output Connector (1.85 mm) (Option 567)	5065-9852	2-59	N/A	
RF Output Connector (2.4 mm) (Options 532, 540 and 550)	5063-1700	2-60	N/A	
RF Output Connector (3.5 mm) (Option 520)	E8251-60110	2-61	08673-60040	2-61
RF Output Connector (Type-N) (E8663D and Option 520)	08559-60002	2-62	08559-60002	2-62

- a. Requires firmware version C.06.00 or greater.
- b. Requires firmware version C.06.17.
 - Send SERV:REPL:FRAC command if E8251-60647 rev. is A0100 or A0101.
- c. Requires firmware version C.04.17 or greater.
- d. Requires firmware version C.04.53 or greater.
- e. Requires the temperature compensation resistor pack on A25B to be installed.
- f. Requires firmware version C.05.31 or greater.

Assemblies from the Inside Front Panel View

Figure 2-1 Assemblies from the Inside Front Panel View for with serial prefixes < US/MY5XXX3XXX¹

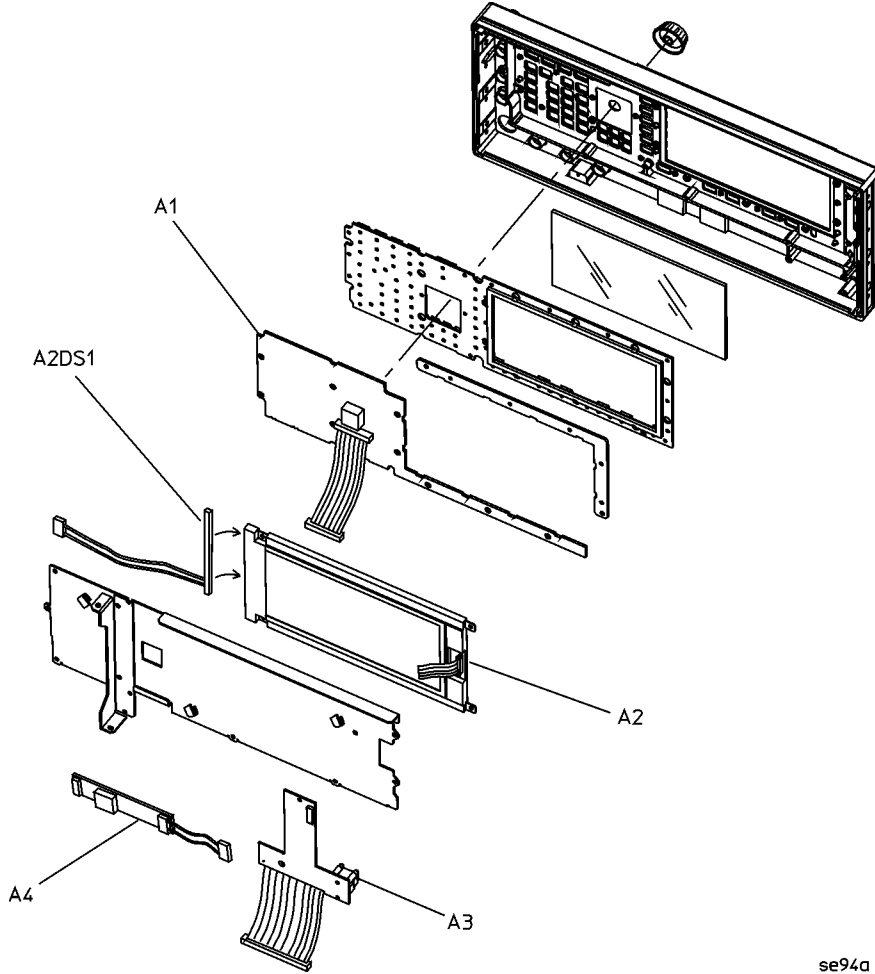

1. Applicable if the A2 does not have the most current LCD.

Figure 2-2 Assemblies from the Inside Front Panel View for with serial prefixes >
US/MY5XXX3XXX

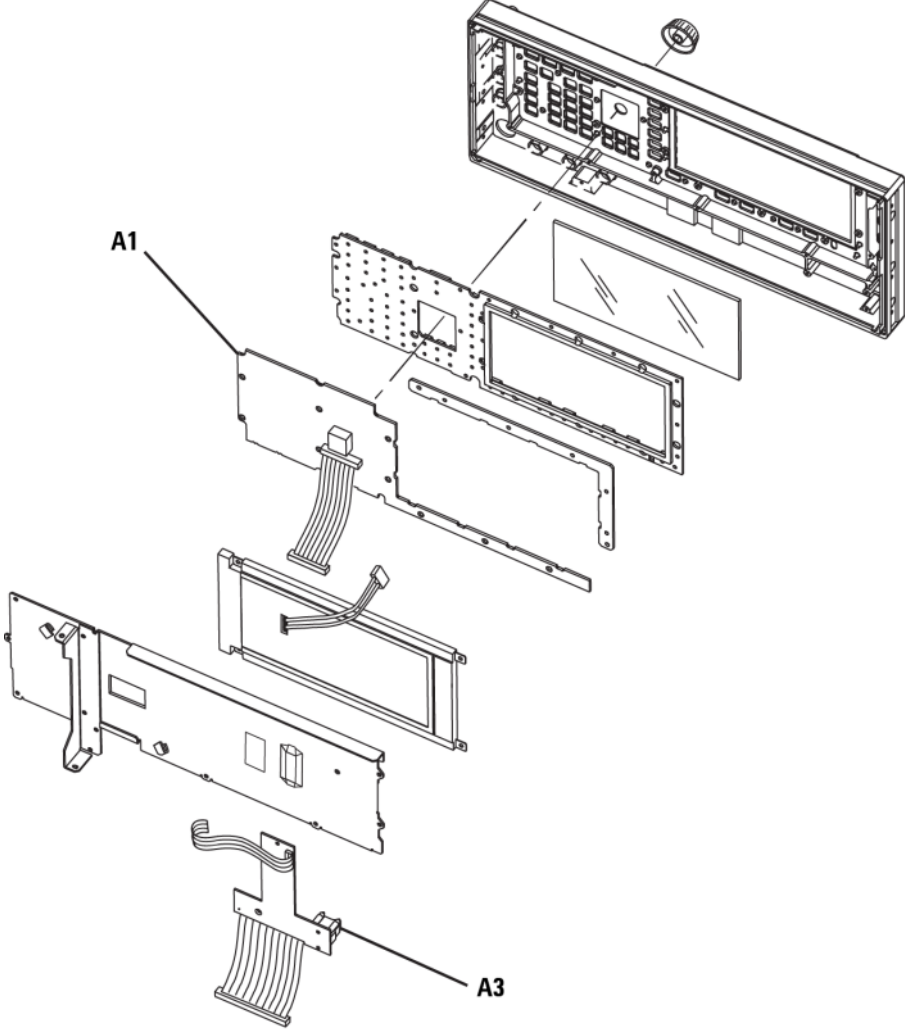

se94a_noinv

Assemblies from a Top View

Figure 2-3 Assemblies from a Top View (E8257D Option 520/540 and E8663D)

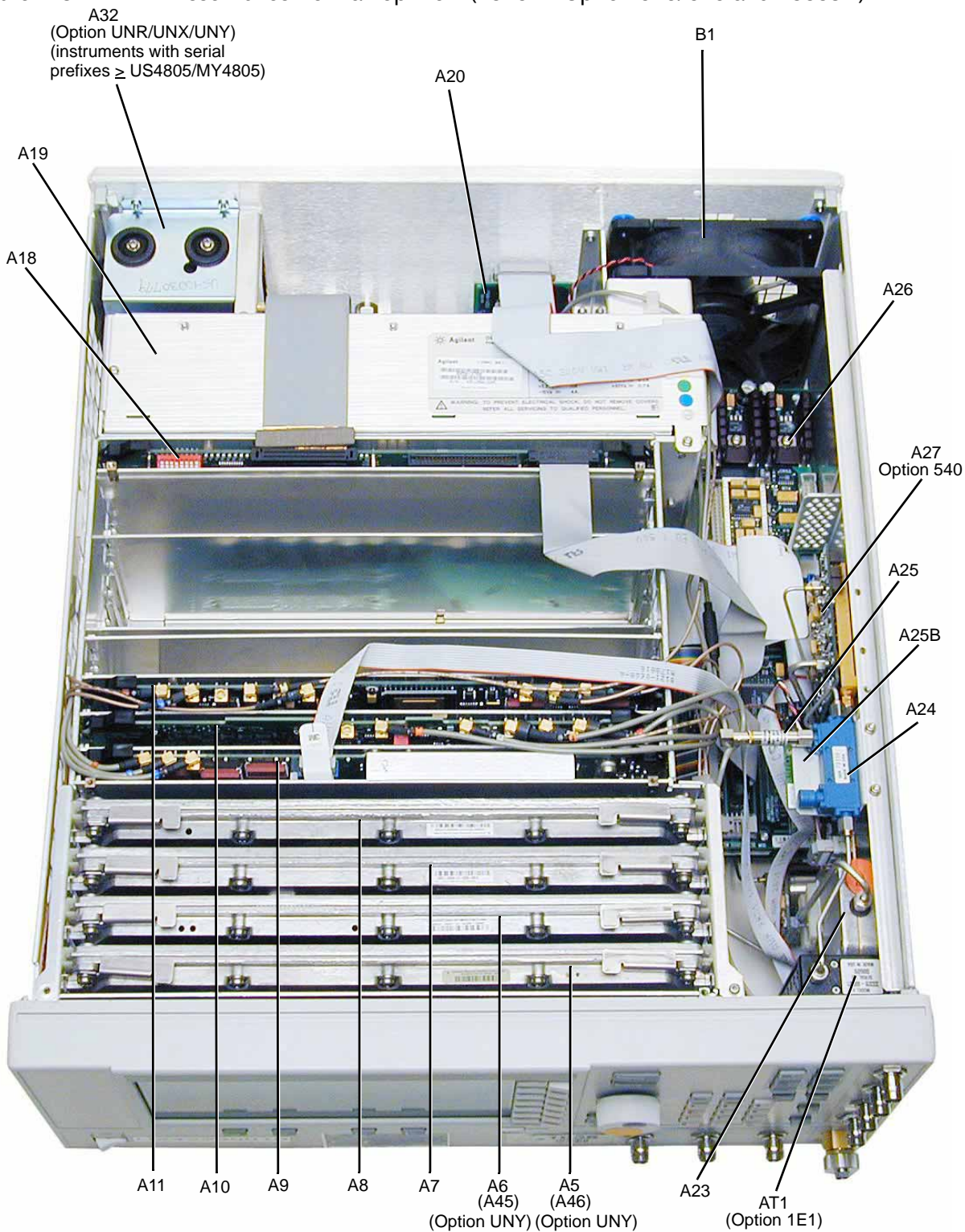
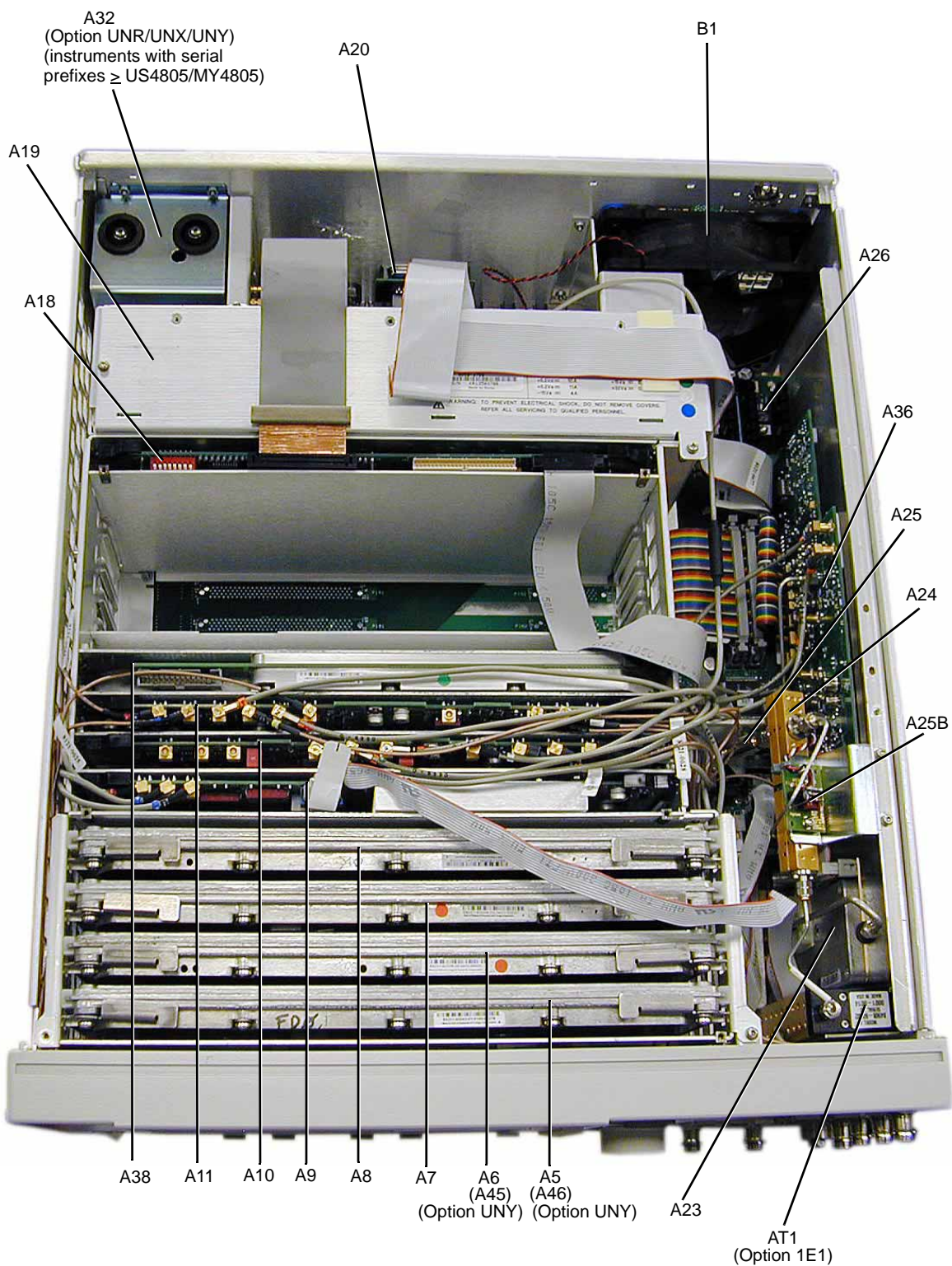

Figure 2-4 Assemblies from a Top View (E8257D Option 521)



Replaceable Parts
Assemblies from a Top View

Figure 2-5 Assemblies from a Top View (E8257D Option 550/567)



Replaceable Parts
Assemblies from a Top View

Figure 2-6 Assemblies from a Top View (E8267D Option 520)

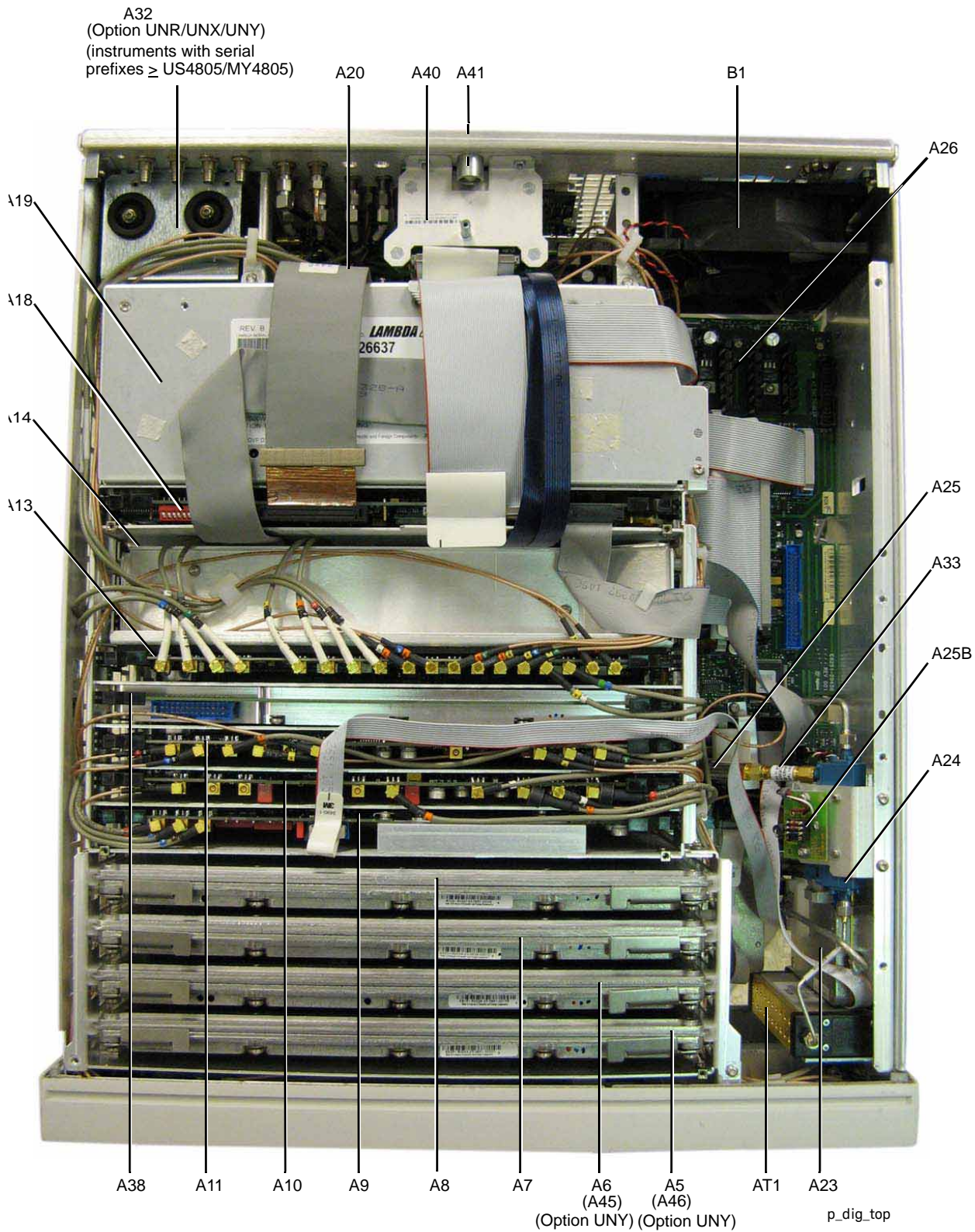

Replaceable Parts
Assemblies from a Top View

Figure 2-7 Assemblies from a Top View (E8267D Option 532/544)

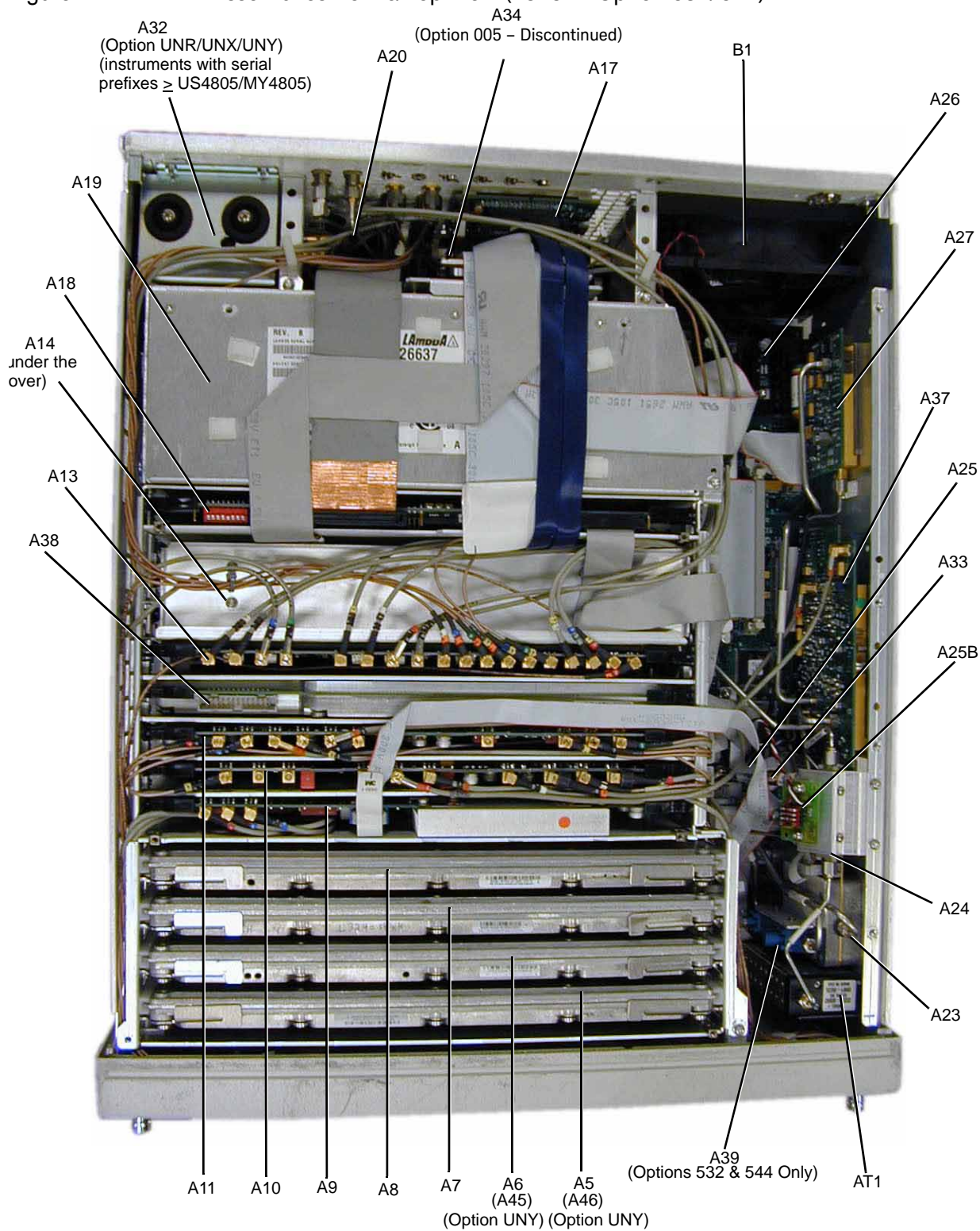

Assemblies from a Microcircuit Deck View

Figure 2-8 Assemblies from a Microcircuit Deck View (E8257D Option 520/540 and E8663D)

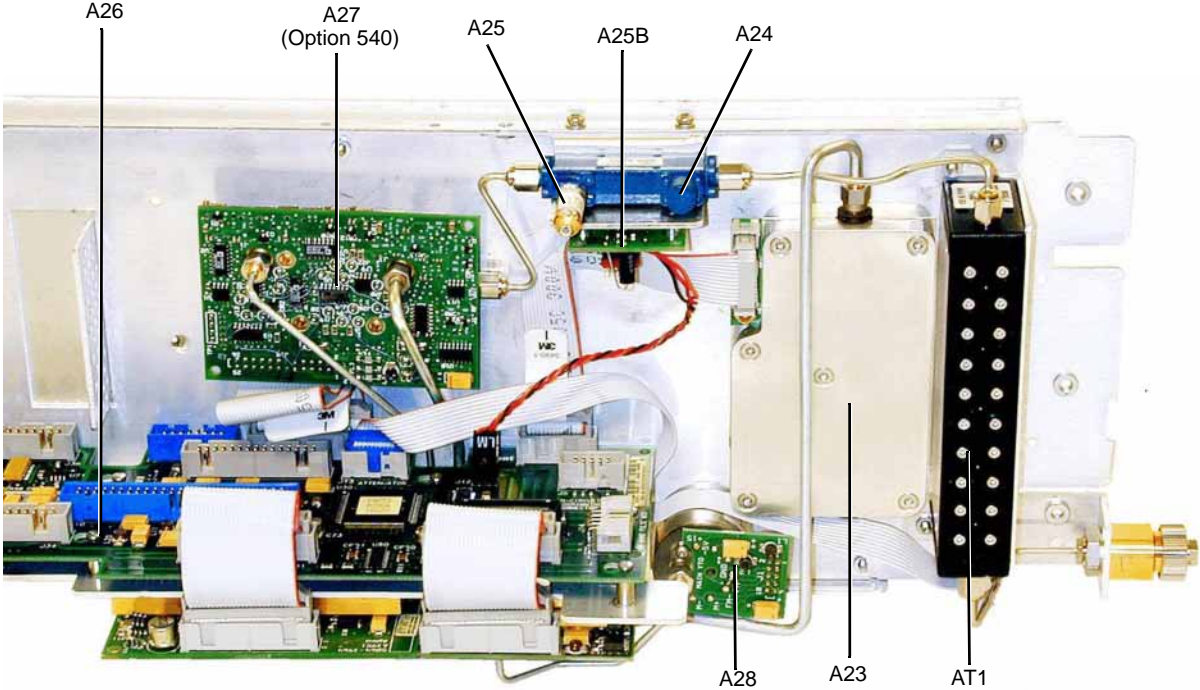

Figure 2-9 Assemblies from a Microcircuit Deck View (E8257D Option 521)

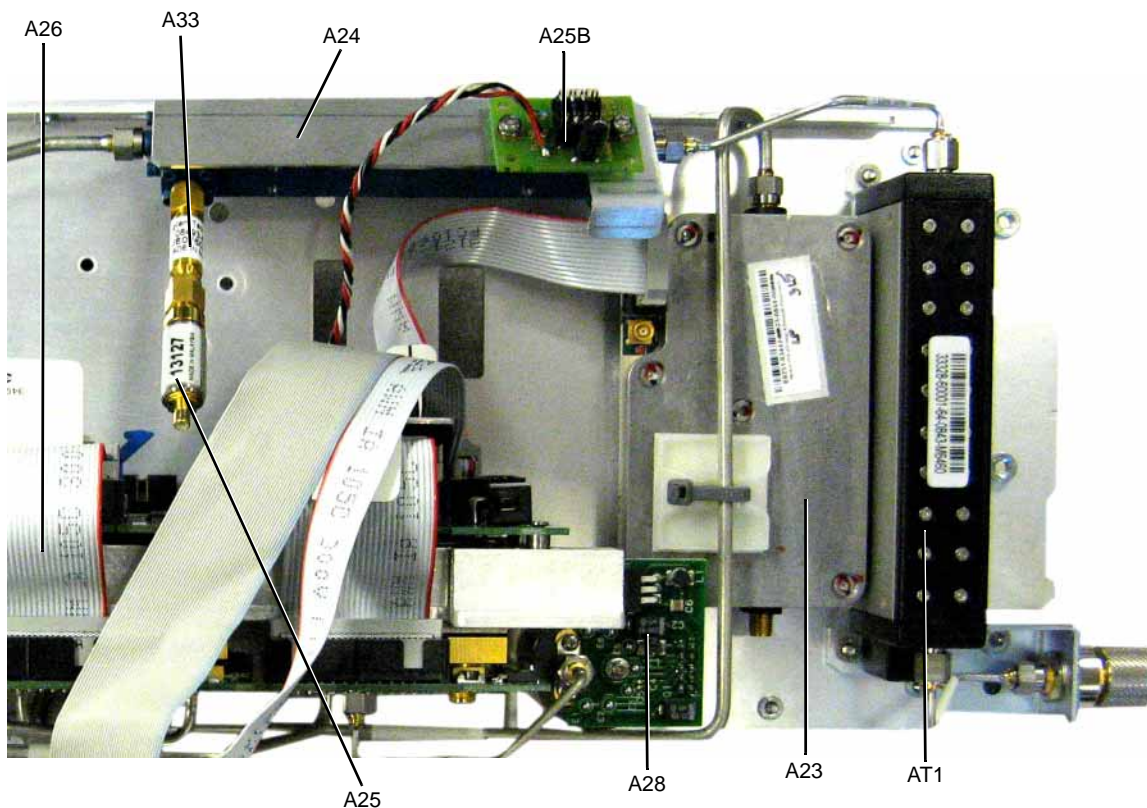

Figure 2-10 Assemblies from a Microcircuit Deck View (E8257D Option 550/567)

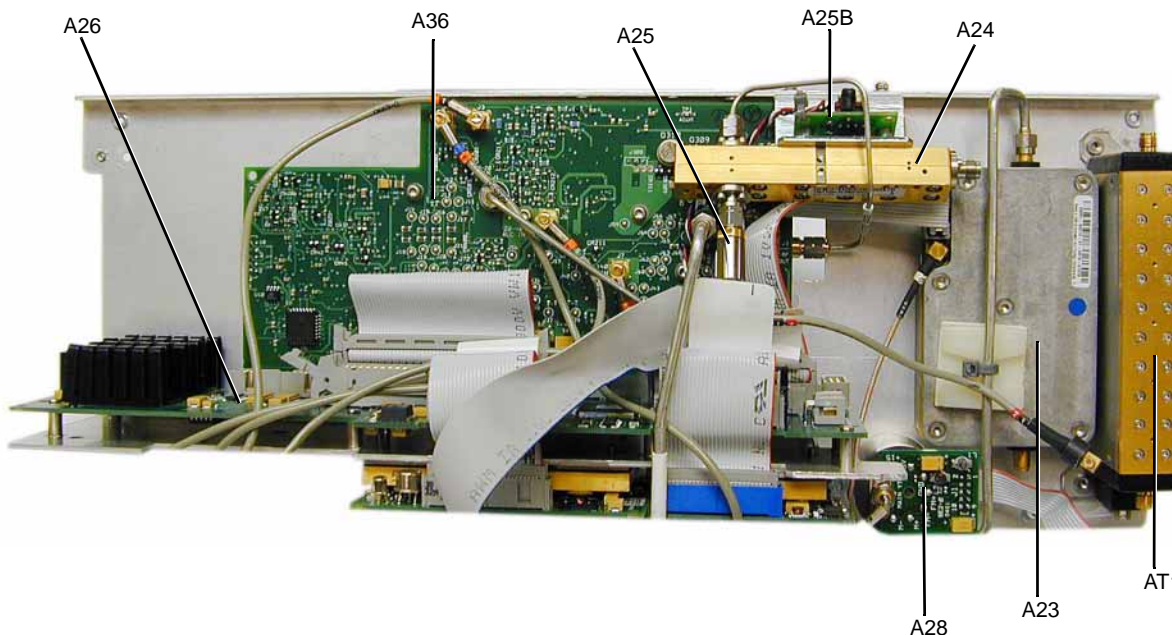

Figure 2-11 Assemblies from a Microcircuit Deck View (E8267D Option 520)

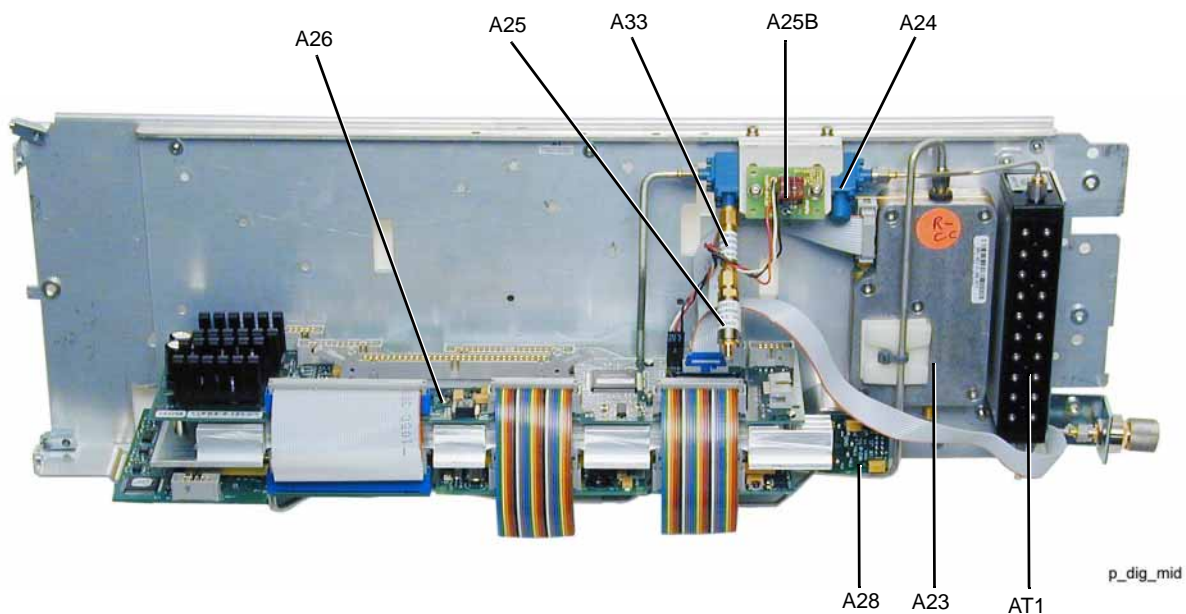
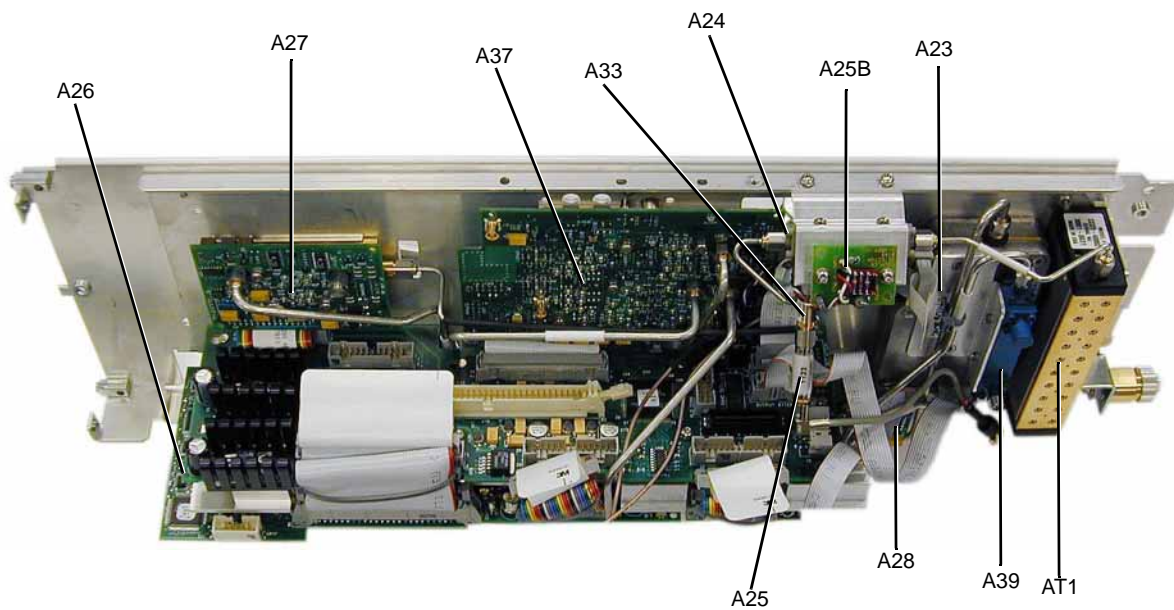

Figure 2-12 Assemblies from a Microcircuit Deck View (E8267D Option 532/544)



Assemblies from a Bottom View

Figure 2-13 Assemblies from a Bottom View (E8257D and E8663D)

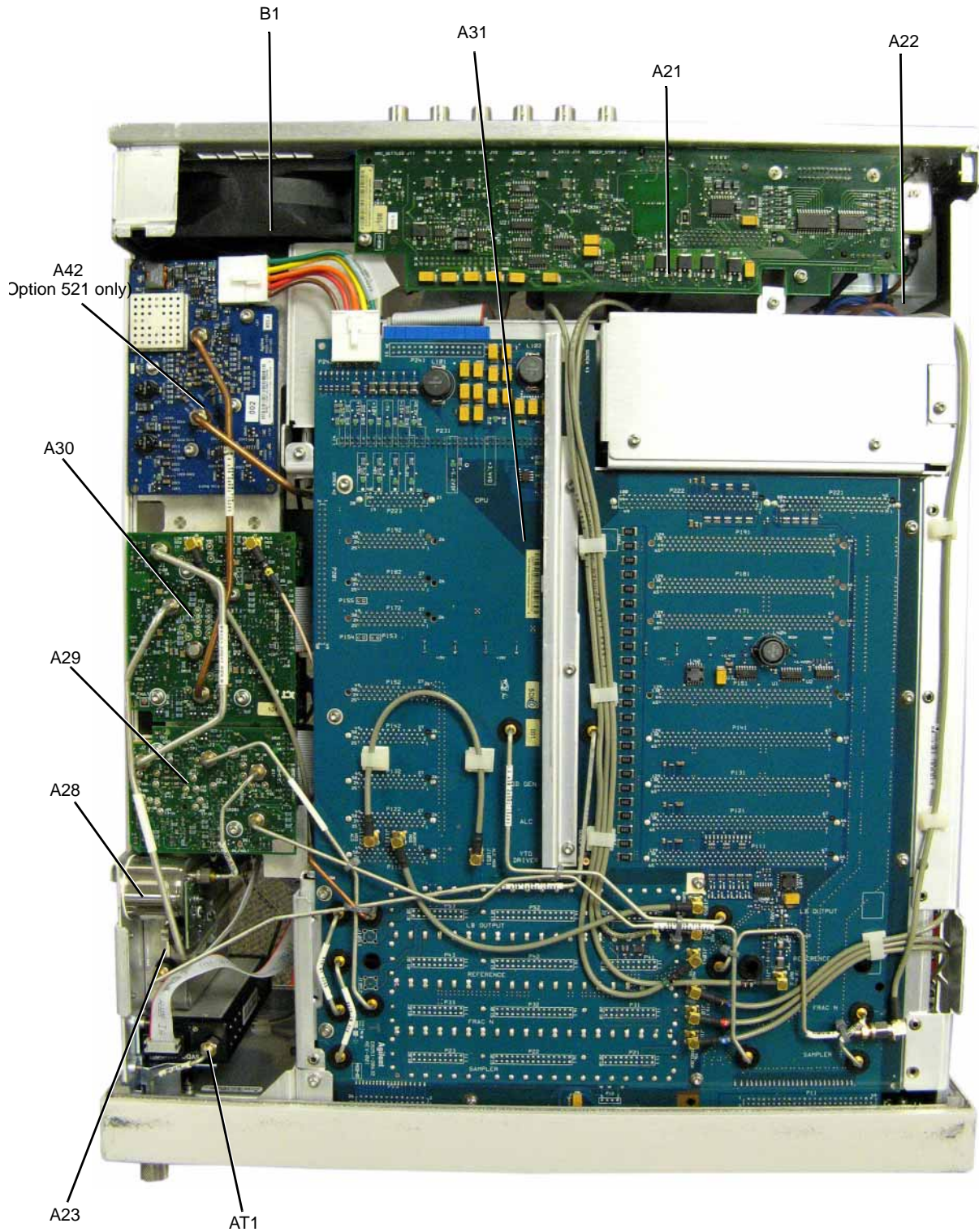
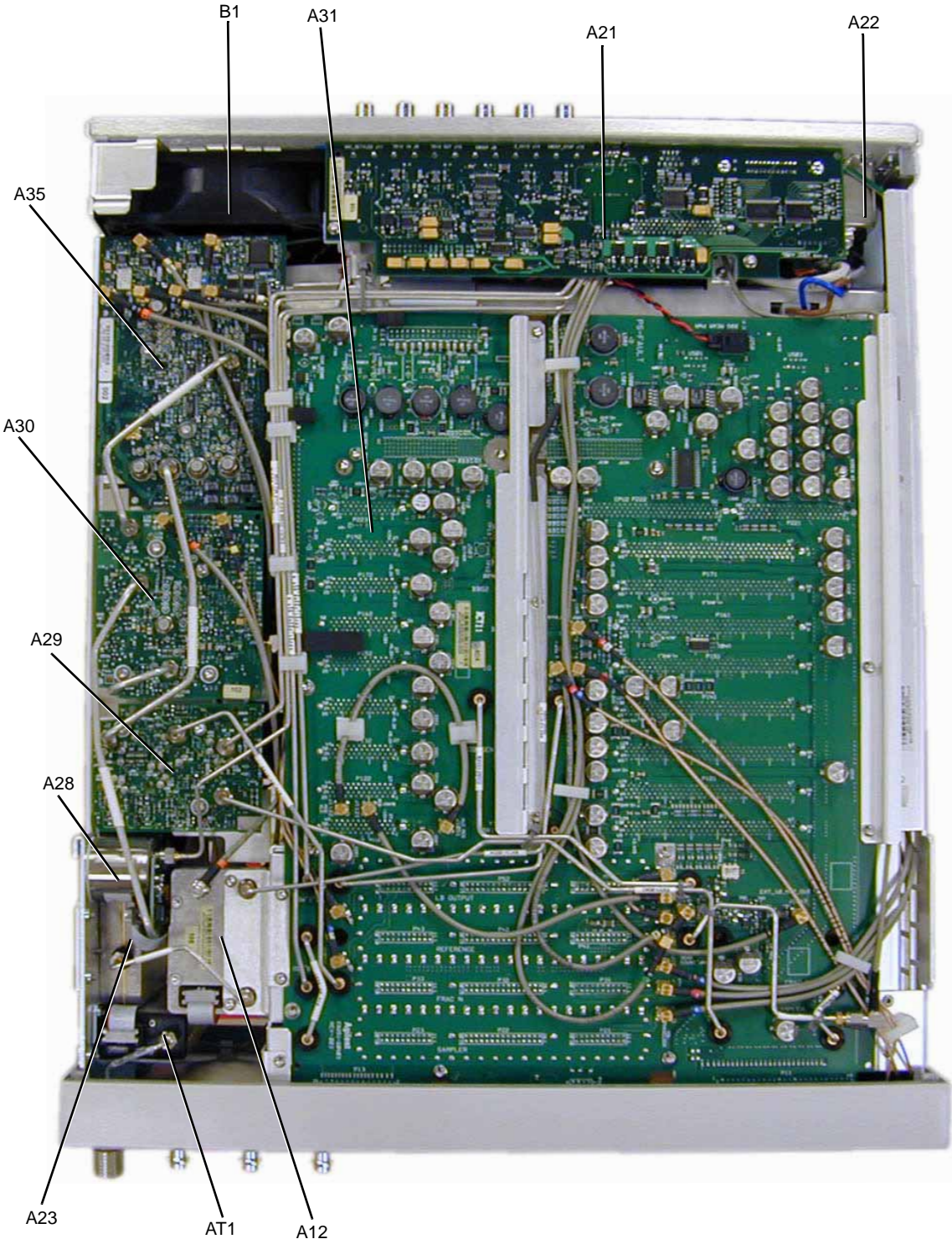
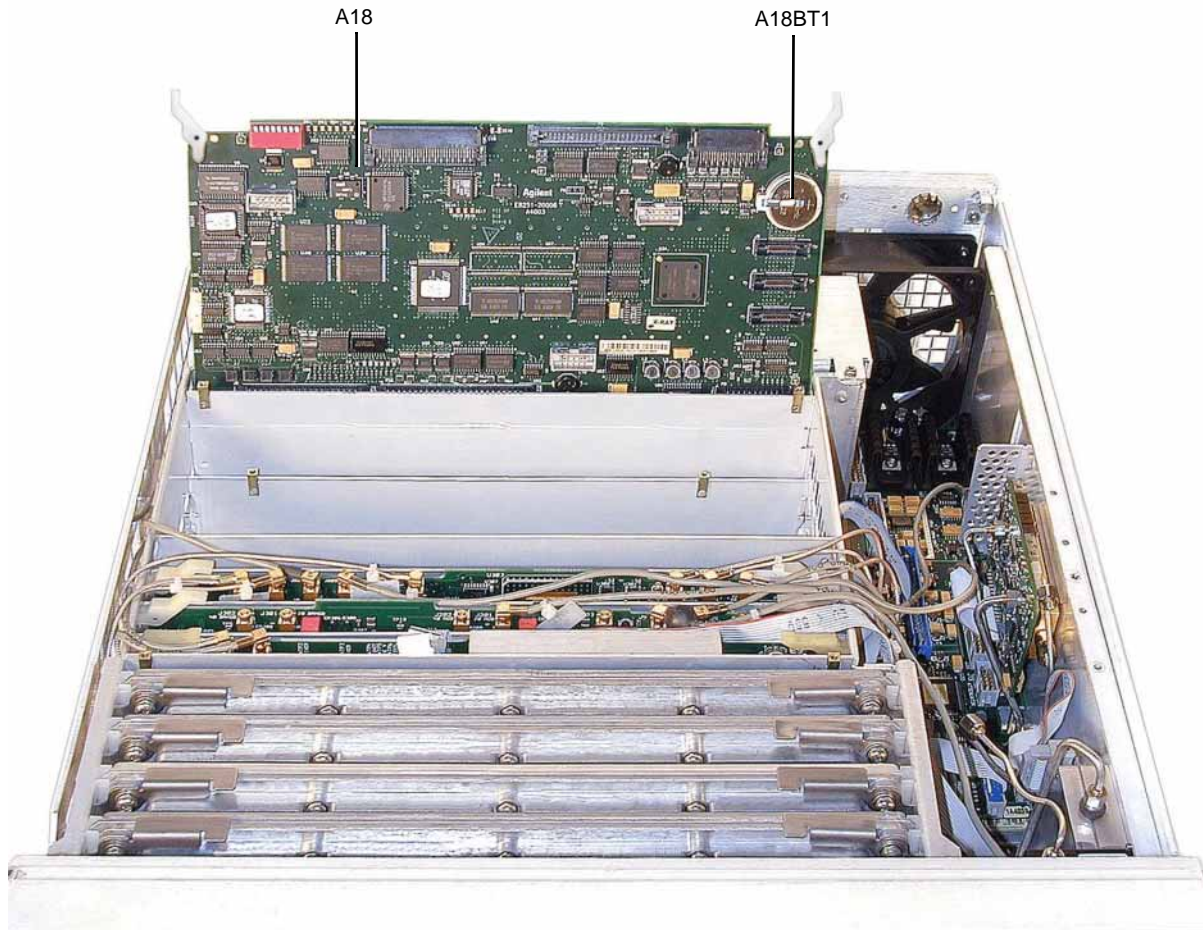

Figure 2-14 Assemblies from a Bottom View (E8267D)



A18BT1 Lithium Battery

Figure 2-15 A18BT1 Lithium Battery



p_se957a

Cables

This section lists part numbers for the cables in your signal generator.

Table 2-4

Reference Designator	Input	Output	Part Number
A1W1 ^a	Ribbon Cable, A1 Keyboard	A31P13	(part of A1)
A2DS1W1 ^a	Wire Cable, A2DS1	A4 Inverter	(part of A2)
A4W1 ^a	Wire Cable, A4 Inverter	A31P12	(part of A4)
A22W1 ^a	A22 Line Module	A19 Power Supply	(part of A22)
A22W2 ^a	A22 Line Module	Chassis ground post on Rear Panel and A19 Power Supply	(part of A22)
A25BW1 ^a	Wire Cable, A25B Highband Detector Bias board	A26J12	(part of A25)
A32W1 ^a	Wire Cable, A32 10 MHz Crystal Oscillator	A21P2	(part of A32)
B1W1 ^a	Wire Cable, B1 Fan	A21P251	(part of B1)
W1	Front Panel (EXT 1)	A11J401	8121-0628
W2	Front Panel (EXT 2)	A11J402	8121-0628
W3	Front Panel (LF OUTPUT)	A11J403	8121-0628
W4	Front Panel (ALC INPUT)	A10J4	8121-0859
W5	Front Panel (PULSE/TRIGGER GATE INPUT)	A11J201	8121-0625
W6	Front Panel (PULSE VIDEO OUT)	A11J203	8121-0625
W7	Front Panel (PULSE SYNC OUT)	A11J202	8121-0625
W8			
for instruments with serial prefix < US/MY5XXX3XXX	A3 Power Switch (DATA CABLE)	A2 Display	8121-0165
for instruments with serial prefix > US/MY5XXX3XXX	A3 Power Switch (DATA CABLE)	A2 Display	8121-0689
W9	A3P1	A31P11	8121-0614
W10	A9J3	A31J1031	8121-0624
W11	A9J4	A31J1021	8121-0624
W12	A9J5	A28J1	8121-0608

Replaceable Parts
Cables

Table 2-4 (Continued)

Reference Designator	Input	Output	Part Number
W13	A10J201	A30J6	8121-0624
W14	A10J5	A23J104	8121-0627
W15	A10J3	A25 40 GHz Highband Detector	8121-0900
W16	A11J204	A12 Pulse Modulator Board	8121-0623
W17	A11J205	A30J7	8121-0626
W18	A18J1	A21J3	8121-0617
W19	A18J2	A26J30	8121-0619
W20	A20J1	A26J20	8121-0677
W21	A31J1043	Rear Panel (10MHz OUT)	8121-0622
W22	A31J1042	Rear Panel (10MHz IN)	8121-0622
W23	A21J2	A31P241	8121-0611
W24	Semi-Rigid Cable, A24 (output)	AT1 115 dB Mechanical Attenuator (Option 1E1)	E8251-20025
W25	Semi-Rigid Cable, AT1 (output)	2.4 mm RF Output adapter (Option 1E1)	E8251-20028
W26 (Options 532 and 540)	Semi-Rigid Cable, A24 40 GHz Highband Coupler	2.4mm RF Output adapter (models without Option 1E1)	E8251-20035
W27	A23J2	A30J3	E8251-20031
W28	A23J100	A26J15	8121-0616
W29	A27J10	A26J33	8121-0613
W30 (Option 540)	A27J2	A24 Highband Coupler input	E8251-20024
W31 (Option 540)	A27J3	A30J2	E8251-20023
W32 (Option 540)	A27J1	A30J4	E8251-20022
W33	A26J32	A29J10	8121-0613
W34	A26J31	A30J10	8121-0613
W35	A26J10	A31P201	8121--615
W36	Ribbon Cable, AT1 90 dB/115 dB Mechanical Attenuator	A26J13	8121-0982
W37 (E8257D)	Semi-Rigid Cable, A23 Lowband Coupler/Detector	A31 Motherboard (Output)	E8251-20225

Replaceable Parts
Cables

Table 2-4 (Continued)

Reference Designator	Input	Output	Part Number
W38 (E8257D)	Semi-Rigid Cable, A28 YIG Oscillator (out)	A29J1	E8251-20014
W39	A29J4	A31 Motherboard (Sampler)	E8251-20343
W40	A29J3	A31 Motherboard (Frac-N)	E8251-20224
W41 (E8257D)	A29J2	A30J1	E8251-20017
W42	Semi-Rigid Cable, A31 Motherboard (Sampler)	A31 Motherboard (Reference)	E8251-20226
W43	Semi-Rigid Cable, A31 Motherboard (Frac-N)	A31 Motherboard (Output)	E8251-20226
W44	A31J1051	A31J1122	8121-0620
W45	A31J1055	A31J1121	8121-0620
W46	Semi-Rigid Cable, A31 Motherboard (Sampler)	A31 Motherboard (Frac-N)	E8251-20029
W47	A32J1	A31J1041	8121-0621
W48	A32J2	Rear Panel (10 MHz EFC)	8120-6839
W49 (E8267D)	Front Panel (I IN)	A13J7	8121-0901
W50 (E8267D)	Front Panel (Q IN)	A13J8	8121-0901
W51 (E8267D)	Front Panel (DATA)	A31J500	8121-0628
W52 (E8267D)	Front Panel (DATA CLOCK)	A31J501	8121-0628
W53 (E8267D)	Front Panel (SYMBOL SYNC)	A31J502	8121-0628
W54	A9J9	A31J1032	8121-0624
W55	A10J304	Rear Panel (SOURCE MOD INTERFACE)	8121-0636
W56 (E8267D)	A13J14	Rear Panel (-Q OUT)	8121-0901
W57 (E8267D)	A13J13	Rear Panel (-I OUT)	8121-0901
W58 (E8267D)	A13J12	Rear Panel (Q OUT)	8121-0901

Replaceable Parts
Cables

Table 2-4 (Continued)

Reference Designator	Input	Output	Part Number
W59 (E8267D)	A13J11	Rear Panel (I OUT)	8121-0901
W60 (Std. E8267D or with Option 015)	A13J10	A31J1052	8121-0626
W61 (Std. E8267D or with Option 015)	A13J9	A31J1053	8121-0626
W62 (E8267D)	A13J6	A35J7	8121-0624
W63 (E8267D)	A13J5	A35J6	8121-0624
W64 (E8267D)	A14J13	A17P2	8121-0920
W65 (E8267D)	A14J800	Rear Panel (BASEBAND GEN REF IN)	8121-0901
W66 (E8267D only)	A18P2	A34 Internal Hard Drive	8121-0685
W67 (E8267D)	Semi-Rigid Cable, A31 Motherboard	Rear Panel (.25-3.5 GHz COH CARRIER)	E8251-20223
W68 (E8267D)	A17P4	A31J250	8121-0925
W69	A26J14	A12 Pulse Modulator Board	8121-0912
W70 (E8267D)	A26J34	A35 I/Q MOD	8121-0615
W71 (Option 520) (Option 1EM)	Semi-Rigid Cable, A24 20 GHz Highband Coupler IN	A30J2	E8251-20093
W72 (Option 520) (Option 1EM)	Semi-Rigid Cable, A24 20 GHz Highband Coupler output	AT1 115 dB Mechanical Attenuator (Option 1E1) input	E8251-20094
W73 (Option 1EM)	Semi-Rigid Cable, AT1 115 dB Mechanical Attenuator	3.5mm or Type-N RF Output adapter (RF OUT)	E8251-20095
W74	Semi-Rigid Cable, A24 20 GHz Highband Coupler (input)	A30J2	E8251-20021
W75	Semi-Rigid Cable, A23 Lowband Coupler/Detector	A12 Pulse Modulator Board	E8251-20033

Replaceable Parts
Cables

Table 2-4 (Continued)

Reference Designator	Input	Output	Part Number
W76	Semi-Rigid Cable, A12 Pulse Modulator Board	A31 Motherboard, Lowband Switch Filter (out)	E8251-20334
W77 (E8267D)	A29J2	A35J1	E8251-20018
W78 (E8267D)	A35 I/Q MOD	A37J1	E8251-20217
W79 (E8267D with prefixes <US4722/MY4722)	A35J9	Rear Panel (WIDEBAND Q INPUT)	8121-0628
W80 (E8267D with prefixes <US4722/MY4722)	A35J106	Rear Panel (WIDEBAND I INPUT)	8121-0628
W81 (1.85 mm connector) (Option 1EM)	Semi-Rigid Cable, A24 67 GHz High band Coupler (output)	AT1 90 dB Mechanical Attenuator (input)	E8251-20320
W82 (Options 532 & 544) (Option 1EM)	Semi-Rigid Cable, A24 50 GHz Highband Coupler	2.4 mm RF Output connector (models without Option 1E1)	E8251-20309
W83 (Option 1EM)	A27J2	A24 Highband Coupler input	E8251-20070
W84 (Option 1EM)	Semi-Rigid Cable, A24 40 GHz Highband Coupler output	AT1 115 dB Mechanical Attenuator (Option 1E1) input	E8251-20071
W85 (Option 1EM)	Semi-Rigid Cable, AT1 115 dB Mechanical Attenuator	2.4mm RF Output connector (RF OUT)	E8251-20072
W86 (Option 520)	Semi-Rigid Cable, AT1 output	3.5 mm or Type-N RF Output connector	E8251-20027
W87 (Option 540) (Option 1EM)	Semi-Rigid, A24 40 GHz Highband Coupler in	RF Output adapter (models without Option 1E1)	E8251-20092
W88 (Option 520) (Option 1EM)	Semi-Rigid, A24 20 GHz Highband Coupler in	RF Output adapter (models without Option 1E1)	E8251-20096
W89 (Options 550 & 567)	Semi-Rigid Cable, A24 20 GHz Highband Coupler	3.5mm RF Output connector (models without Option 1E1)	E8251-20346
W90 (E8267D)	A14J21	A17P1	8121-0690
W91 (Options 550 & 567) (Option 1EM)	Semi-Rigid Cable, A24 67 GHz Highband Coupler (output)	1.85 mm RF Output connector (models without Option 1E1)	E8251-20318

Replaceable Parts
Cables

Table 2-4 (Continued)

Reference Designator	Input	Output	Part Number
W92 (Option 550 & 567)	Semi-Rigid Cable, AT1 115 dB Mechanical Attenuator (output)	1.85 mm RF Output connector	E8251-20321
W93 (Options 532 & 544) (Option 1EM)	Semi-Rigid Cable, A24 50 GHz Highband Coupler (output)	AT1 115 dB Mechanical Attenuator (output)	E8251-20312
W94 (Options 550 & 567) (Option 1EM)	Semi-Rigid Cable, AT1 90 dB Mechanical Attenuator (output)	1.85 mm RF Output connector	E8251-20322
W95 (Options 550 & 567)	A10J202	A36J6	8120-6990
W96 (Options 550 & 567)	A11J206	A36J5	8121-6990
W97 (E8267D)	A35J8	A37J8	8121-0627
W98	A30J1	A37J2	E8251-20218
W99 (Options 532 & 544)	A37J7 (backside)	A26J34	8121-1241
W100	A27J2 (RF out)	A37J5 (LO in)	E8251-20216
W101	A28	A39 (in)	E8251-20331
W102 (Options 532 & 544)	A37J4 (RF out)	Semi-Rigid Cable, A24 50 GHz Highband Coupler (in)	E8251-20310
W103 (Options 532 & 544)	A30J2	A37J3	E8251-20219
W104 (E8267D)	A27J1	A35J3	E8251-20215
W105 (E8267D)	A35J4	A29J3	E8251-20077
W106 (Options 550 & 567)	A36J1	A30J4	E8251-20313
W107 (Options 550 & 567)	A36J2	A30J2	E8251-20314
W108 (Options 550 & 567)	A36J4	A30J6	8120-6990
W109 (Options 550 & 567)	A10J201	A36J3	8120-6990

Replaceable Parts
Cables

Table 2-4 (Continued)

Reference Designator	Input	Output	Part Number
W110 (Options 532 & 544)	A10J202	A37J6	8121-6990
W111 (Options 550 & 567)	A10J203	A36J7	8120-6990
W112 (Options 550 & 567)	A36J3/RF OUT	Semi-Rigid Cable, A24 67 GHz Highband Coupler	E8251-20315
W113 (Options 550 & 567)	A36J10	A26J34	8121-1240 (ribbon)
W114 (Options 532 & 544)	A11J206	A37J9	8121-6990
W115 (E2867D)	A29J1	A39 Directional Sweep Coupler (out)	E8251-20308
W116 (Options 532 & 544)	A27J10	A26J36	8121-1285
W117 (Options 550 & 567)	Semi-Rigid Cable, A24 67 GHz High band Coupler (output)	AT1 90 dB Mechanical Attenuator (input)	E8251-20319
W118 (with Option 1EH) (without Option UNW)	A31 Motherboard (LB Filter Output)	A31 Motherboard (Lowband Switch Filter) (IN)	E8251-20332
W119 (with Option 1EH)	A31 Motherboard (Lowband Switch Filter) (OUT)	A23 Lowband Coupler/Detector (IN)	E8251-20333
W120 (with Option 1EH)	A31 Motherboard (LB Filter Output)	A23 Lowband Coupler/Detector	E8251-20342
W121 (E8257D) (Option 520)	A29 20 GHz Doubler	AT1 115 dB Mechanical Attenuator (IN)	E8251-20026
W122 ^b (E8267D)	A10J303	Rear Panel (ALC HOLD)	0625-4806
W123 ^c (E8267D with Option H16/016)	A13J15	Rear Panel (Wideband Q In (+))	8121-1667
W124 ^d (E8267D with Option H16/016)	A13J16	Rear Panel (Wideband -Q In (-))	8121-1667
W125 ^d (E8267D with Option H16/016)	A13J19	Rear Panel (Wideband I In (+))	8121-1667

Replaceable Parts
Cables

Table 2-4 (Continued)

Reference Designator	Input	Output	Part Number
W126 ^d (E8267D with Option H16/016)	A13J20	Rear Panel (Wideband -I In (-))	8121-1667
W127 ^d (E8267D with Option H16/016)	A13J17	A35J109	8121-1616
W128 ^e (E8267D with Option H16/016)	A13J18	A35J107	8121-1616
W129 ^e (E8267D with Option H16/016)	A13J21	A35J108	8121-1616
W130 ^e (E8267D with Option H16/016)	A13J22	A35J106	8121-1616
W131 ^e (E8267D with Option H16/016)	A13J9	A31J1053	8121-1618
W132 ^f (E8267D with Option H16/016)	A13J10	A31J1052	8121-1618
W133 (Option 520)	Semi-Rigid, A24 20 GHz Highband Coupler (output)	RF Output adapter (models without Option 1E1)	E8251-20034
W134	A30J1	A35 I/Q Mod	E8251-20019
W135	1 GHz Out (Rear Panel)	W122 ^f	8120-5068
W136 ^g (E8267D only)	A18P2	A40 Compact Flash PCA	8182-1807

- a. This cable is not replaceable by itself. You must order the corresponding assembly.
- b. Requires firmware version C.04.71 or greater.
- c. For instruments with serial prefixes < US4722/MY4722 you must replace all matched cables, W123 thru W126, the first time and order 4 SMA bulkhead adapters, part number 1250-1666.
- d. For instruments with serial prefixes < US4722/MY4722 you must replace all matched cables, W127 thru W130, the first time.
- e. For instruments with serial prefixes < US4722/MY4722 you must replace the two matched cables, W131 and W132, the first time.
- f. For instruments with serial prefixes > US4805/MY4805. For instruments with serial prefixes < US4805/MY4805 this cable has one end connected to the rear panel, the other end is left disconnected and the whole cable is zip tied in a loop.

Replaceable Parts
Cables

g. For instruments with serial prefixes ³ US4829/MY4829.

Table 2-5

Reference Designator	Input	Output	Part Number
A1W1 ^a	Ribbon Cable, A1 Keyboard	A31P13	(part of A1)
A2DS1W1 ^a	Wire Cable, A2DS1	A4 Inverter	(part of A2)
A4W1 ^a	Wire Cable, A4 Inverter	A31P12	(part of A4)
A22W1 ^a	A22 Line Module	A19 Power Supply	(part of A22)
A22W2 ^a	A22 Line Module	Chassis ground post on Rear Panel and A19 Power Supply	(part of A22)
A25BW1 ^a	Wire Cable, A25B Highband Detector Bias board	A26J12	(part of A25)
A32W1 ^a	Wire Cable, A32 10 MHz Crystal Oscillator	A21P2	(part of A32)
B1W1 ^a	Wire Cable, B1 Fan	A21P251	(part of B1)
W1	Front Panel (EXT 1)	A11J401	8121-0628
W2	Front Panel (EXT 2)	A11J402	8121-0628
W3	Front Panel (LF OUTPUT)	A11J403	8121-0628
W4	Front Panel (ALC INPUT)	A10J4	8121-0609
W5	Front Panel (PULSE/TRIGGER GATE INPUT)	A11J201	8121-0625
W6	Front Panel (PULSE VIDEO OUT)	A11J203	8121-0625
W7	Front Panel (PULSE SYNC OUT)	A11J202	8121-0625
W8			
for instruments with serial prefix < US/MY5XXX3XXX	A3 Power Switch (DATA CABLE)	A2 Display	8121-0165
for instruments with serial prefix > US/MY5XXX3XXX	A3 Power Switch (DATA CABLE)	A2 Display	8121-0689
W9	A3P1	A31P11	8121-0614
W10	A9J3	A31J1031	8121-0624
W11	A9J4	A31J1021	8121-0624
W12	A9J5	A28J1	8121-0608

Replaceable Parts
Cables

Table 2-5 (Continued)

Reference Designator	Input	Output	Part Number
W13	A10J201	A30J6	8121-0624
W14	A10J5	A23J104	8121-0627
W15	A10J3	A25 20/40/50/67 GHz Highband Detector	N8210-60201
W16	A11J204	A12 Pulse Modulator Board	8121-0623
W17	A11J205	A30J7	8121-0626
W18	A18J1	A21J3	8121-0617
W19	A18J2	A26J30	8121-0619
W20	A20J1	A26J20	8121-0677
W21	A31J1043	Rear Panel (10MHz OUT)	8121-0622
W22	A31J1042	Rear Panel (10MHz IN)	8121-0622
W23	A21J2	A31P241	8121-0611
W24 (Option 520)	Semi-Rigid Cable, A24 20 GHz Highband Coupler (output)	AT1 115 dB Mechanical Attenuator (Option 1E1)	E8251-20026
W25	Semi-Rigid Cable, AT1 (output)	2.4 mm RF Output adapter (Option 1E1)	E8251-20028
W26 (Options 532 and 540)	Semi-Rigid Cable, A24 40 GHz Highband Coupler (output)	2.4mm RF Output adapter (models without Option 1E1)	E8251-20035
W27	Semi-Rigid Cable, A23 Lowband Coupler/Detector	A30J3	E8251-20031
W28	A23J100	A26J15	8121-0616
W29	A27J10	A26J33	8121-0613
W30 (Option 540)	A27J2	A24 Highband Coupler (input)	E8251-20024
W31 (Option 540)	A27J3	A30J2	E8251-20023
W32 (Option 540)	A27J1	A30J4	E8251-20022
W33	A26J32	A29J10	8121-0613
W34	A26J31	A30J10	8121-0613
W35	A26J10	A31P201	8121-0615

Replaceable Parts
Cables

Table 2-5 (Continued)

Reference Designator	Input	Output	Part Number
W36	Ribbon Cable, AT1 90 dB/115 dB Mechanical Attenuator	A26J13	8121-0982
W37 (E8257D & E8663D)	Semi-Rigid Cable, A23 Lowband Coupler/Detector	A31 Motherboard (Output)	E8251-20225
W38 (E8257D & E8663D)	Semi-Rigid Cable, A28 YIG Oscillator (output)	A29J1	E8251-20014
W39	A29J4	A31 Motherboard (Sampler)	E8251-20343
W40	A29J3	A31 Motherboard (Frac-N)	E8251-20224
W41 (E8257D & E8663D)	A29J2	A30J1	E8251-20017
W42	Semi-Rigid Cable, A31 Motherboard (Sampler)	A31 Motherboard (Reference)	E8251-20226
W43	Semi-Rigid Cable, A31 Motherboard (Frac-N)	A31 Motherboard (Output)	E8251-20226
W44	A31J1051	A31J1122	8121-0620
W45	A31J1055	A31J1121	8121-0620
W46	Semi-Rigid Cable, A31 Motherboard (Sampler)	A31 Motherboard (Frac-N)	E8251-20029
W47	A32J1	A31J1041	8121-0621
W48	A32J2	Rear Panel (10 MHz EFC)	8120-6839
W49 (E8267D)	Front Panel (I IN)	A13J7	8121-0901
W50 (E8267D)	Front Panel (Q IN)	A13J8	8121-0901
W51 (E8267D)	Front Panel (DATA)	A31J500	8121-0628
W52 (E8267D)	Front Panel (DATA CLOCK)	A31J501	8121-0628
W53 (E8267D)	Front Panel (SYMBOL SYNC)	A31J502	8121-0628
W54	A9J9	A31J1032	8121-0624
W55	A10J304	Rear Panel (SOURCE MOD INTERFACE)	8121-0636

Replaceable Parts
Cables

Table 2-5 (Continued)

Reference Designator	Input	Output	Part Number
W56 (E8267D)	A13J14	Rear Panel (-Q OUT)	8121-0901
W57 (E8267D)	A13J13	Rear Panel (-I OUT)	8121-0901
W58 (E8267D)	A13J12	Rear Panel (Q OUT)	8121-0901
W59 (E8267D)	A13J11	Rear Panel (I OUT)	8121-0901
W60 (Std. E8267D or with Option 015)	A13J10	A31J1052	8121-0626
W61 (Std. E8267D or with Option 015)	A13J9	A31J1053	8121-0626
W62 (E8267D)	A13J6	A35J7	8121-0624
W63 (E8267D)	A13J5	A35J6	8121-0624
W64 (E8267D)	A14J13	A17P2	8121-0920
W65 (E8267D)	A14J800	Rear Panel (BASEBAND GEN REF IN)	8121-0901
W66 (E8267D)	A18P2	A34 Internal Hard Drive	8121-0685
W67 (E8267D)	Semi-Rigid Cable, A31 Motherboard	Rear Panel (.25-3.5 GHz COH CARRIER)	E8251-20223
W68 (E8267D)	A17P4	A31J250	8121-0925
W69	A26J14	A12 Pulse Modulator Board	8121-0912
W70 (E8267D)	A26J34	A35 I/Q MOD	8121-0615
W71 (Option 503/509/520) (Option 1EM)	Semi-Rigid Cable, A24 20 GHz Highband Coupler (input)	A30J2	E8251-20093

Replaceable Parts
Cables

Table 2-5 (Continued)

Reference Designator	Input	Output	Part Number
W72 (Option 503/509/520/521) (Option 1EM)	Semi-Rigid Cable, A24 20 GHz Highband Coupler output	AT1 115 dB Mechanical Attenuator (input)	E8251-20494
W73 (Option 1EM)	Semi-Rigid Cable, AT1 115 dB Mechanical Attenuator	3.5mm or Type-N RF Output adapter (RF OUT)	E8251-20095
W74 (Option 503/509/520)	Semi-Rigid Cable, A24 20 GHz Highband Coupler (input)	A30J2	E8251-20021
W75	Semi-Rigid Cable, A23 Lowband Coupler/Detector	A12 Pulse Modulator Board	E8251-20033
W76	Semi-Rigid Cable, A12 Pulse Modulator Board	A31 Motherboard, Lowband Switch Filter (out)	E8251-20334
W77 (E8267D)	A29J2	A35J1	E8251-20018
W78 (E8267D)	A35 I/Q MOD	A37J1	E8251-20217
W79 (E8267D with prefixes <US4722/MY4722)	A35J9	Rear Panel (WIDEBAND Q INPUT)	8121-0628
W80 (E8267D with prefixes <US4722/MY4722)	A35J106	Rear Panel (WIDEBAND I INPUT)	8121-0628
W81 (1.85 mm connector) (Option 1EM)	Semi-Rigid Cable, A24 67 GHz High band Coupler (output)	AT1 90 dB Mechanical Attenuator (input)	E8251-20320
W82 (Options 532 & 544) (Option 1EM)	Semi-Rigid Cable, A24 50 GHz Highband Coupler	2.4 mm RF Output connector (models without Option 1E1)	E8251-20309
W83 (Option 1EM)	A27J2	A24 Highband Coupler input	E8251-20070
W84 (Option 1EM)	Semi-Rigid Cable, A24 40 GHz Highband Coupler output	AT1 115 dB Mechanical Attenuator (input)	E8251-20071
W85 (Option 1EM)	Semi-Rigid Cable, AT1 115 dB Mechanical Attenuator	2.4mm RF Output connector (RF OUT)	E8251-20072

Replaceable Parts
Cables

Table 2-5 (Continued)

Reference Designator	Input	Output	Part Number
W86 (Options 503/509/520/521)	Semi-Rigid Cable, AT1 output	3.5 mm or Type-N RF Output connector	E8251-20027
W87 (Option 540) (Option 1EM)	Semi-Rigid, A24 40 GHz Highband Coupler in	RF Output adapter (models without Option 1E1)	E8251-20092
W88 (Options 503/509/520/521) (Option 1EM)	Semi-Rigid, A24 20 GHz Highband Coupler (in)	RF Output adapter (models without Option 1E1)	E8251-20096
W89 (Options 550 & 567)	Semi-Rigid Cable, A24 20 GHz Highband Coupler (out)	2.4mm RF Output connector (models without Option 1E1)	E8251-20346
W90 (E8267D)	A14J21	A17P1	8121-0690
W91 (Options 550 & 567) (Option 1EM)	Semi-Rigid Cable, A24 67 GHz Highband Coupler (output)	1.85 mm RF Output connector (models without Option 1E1)	E8251-20318
W92 (Option 550 & 567)	Semi-Rigid Cable, AT1 115 dB Mechanical Attenuator (output)	1.85 mm RF Output connector	E8251-20321
W93 (Options 532 & 544) (Option 1EM)	Semi-Rigid Cable, A24 50 GHz Highband Coupler (output)	AT1 115 dB Mechanical Attenuator (input)	E8251-20312
W94 (Options 550 & 567) (Option 1EM)	Semi-Rigid Cable, AT1 90 dB Mechanical Attenuator (output)	1.85 mm RF Output connector	E8251-20322
W95 (Options 550 & 567)	A10J202	A36J6	8120-6990
W96 (Options 550 & 567)	A11J206	A36J5	8121-6990
W97 (E8267D)	A35J8	A37J8	8121-0627
W98 (E8267D)	A30J1	A37J2	E8251-20218
W99 (E8267D) (Options 532 & 544)	A37J7 (backside)	A26J34	8121-1241

Replaceable Parts
Cables

Table 2-5 (Continued)

Reference Designator	Input	Output	Part Number
W100 (E8267D) (Options 532, 540, & 544)	A27J2 (RF out)	A37J5 (LO in)	E8251-20216
W101 (E8267D) (Options 532 & 544)	A28	A39 Directional Sweep Coupler (input)	E8251-20331
W102 (E8267D) (Options 532 & 544)	A37J4 (RF out)	Semi-Rigid Cable, A24 50 GHz Highband Coupler (input)	E8251-20310
W103 (E8267D) (Options 532 & 544)	A30J2	A37J3	E8251-20219
W104 (E8267D)	A27J1	A35J3	E8251-20215
W105 (E8267D)	A35J4	A29J3	E8251-20077
W106 (Options 550 & 567)	A36J1	A30J4	E8251-20313
W107 (Options 550 & 567)	A36J2	A30J2	E8251-20314
W108 (Options 550 & 567)	A36J4	A30J6	8120-6990
W109 (Options 550 & 567)	A10J201	A36J3	8120-6990
W110 (Options 532 & 544)	A10J202	A37J6	8121-6990
W111 (Options 550 & 567)	A10J203	A36J7	8120-6990
W112 (Options 550 & 567)	A36J3/RF OUT	Semi-Rigid Cable, A24 67 GHz Highband Coupler	E8251-20315
W113 (Options 550 & 567)	A36J10	A26J34	8121-1240 (ribbon)
W114 (Options 532 & 544)	A11J206	A37J9	8121-6990
W115 (E8267D) (Options 532 & 544)	A39 Directional Sweep Coupler (output)	A29J1	E8251-20308

Replaceable Parts
Cables

Table 2-5 (Continued)

Reference Designator	Input	Output	Part Number
W116 (Options 532 & 544)	A27J10	A26J36	8121-1285
W117 (Options 550 & 567)	Semi-Rigid Cable, A24 67 GHz High band Coupler (output)	AT1 90 dB Mechanical Attenuator (input)	E8251-20319
W118 (with Option 1EH) (without Option UNW)	A31 Motherboard (LB Filter Output)	A31 Motherboard (Lowband Switch Filter) (IN)	E8251-20332
W119 (with Option 1EH & UNW)	A31 Motherboard (Lowband Switch Filter) (OUT)	A23 Lowband Coupler/Detector (IN)	E8251-20333
W120 (with Option 1EH)	A31 Motherboard (LB Filter Output)	A23 Lowband Coupler/Detector	E8251-20342
W121 ^b	W137	1 GHz Out (Rear Panel)	8120-5068
W122 ^c (E8267D)	A10J303	Rear Panel (ALC HOLD)	0625-4806
W123 ^d (E8267D with Option 016)	A13J15	Rear Panel (Wideband Q In (+))	8121-1667
W124 ^d (E8267D with Option 016)	A13J16	Rear Panel (Wideband -Q In (-))	8121-1667
W125 ^d (E8267D with Option 016)	A13J19	Rear Panel (Wideband I In (+))	8121-1667
W126 ^d (E8267D with Option 016)	A13J20	Rear Panel (Wideband -I In (-))	8121-1667
W127 ^e (E8267D with Option 016)	A13J17	A35J109	8121-1616
W128 ^e (E8267D with Option 016)	A13J18	A35J107	8121-1616
W129 ^e (E8267D with Option 016)	A13J21	A35J108	8121-1616

Replaceable Parts
Cables

Table 2-5 (Continued)

Reference Designator	Input	Output	Part Number
W130 ^e (E8267D with Option 016)	A13J22	A35J106	8121-1616
W131 ^f (E8267D with Option 016)	A13J9	A31J1053	8121-1618
W132 ^f (E8267D with Option 016)	A13J10	A31J1052	8121-1618
W133 (Options 503/509/520/521)	Semi-Rigid, A24 20 GHz Highband Coupler (output)	RF Output adapter (models without Option 1E1)	E8251-20034
W134 (E8267D)	A30J1	A35 I/Q Mod	E8251-20019
W135	Cable Assembly, A42J9	A31P242	E8251-60850
W136 ^g	A18P2	A40 Compact Flash PCA	8182-1807
W137	Semi-Rigid, A31 Motherboard (Reference)	W121	E8251-20384
W138	Semi-Rigid, A43 Lowband Amp Filter	W140	E8251-20489
W139	A43 Lowband Amp Filter	A11J204	8120-6990
W140	Semi-Rigid, W138	A31 Motherboard (Output)	E8251-20488
W141 (Option 521)	A30J2	Semi-Rigid, A42 20 GHz Power Amp (RF IN)	E8251-20468
W142 (Std. Option 521)	Semi-Rigid, A42 20 GHz Power Amp (RF OUT)	A24 20 GHz Highband Coupler (input)	E8251-20469
W143 (Option 521) (Option 1EM)	Semi-Rigid, A42 20 GHz Power Amp (RF OUT)	A24 20 GHz Highband Coupler (input)	E8251-20470
W143 (Std. Option 521)	Semi-Rigid, A24 20 GHz Highband Coupler (output)	AT1 115 dB Mechanical Attenuator (input)	E8251-20473
W144 (Option 521)	A10J3	A25 20 GHz Highband Detector	N8210-60201
W145 (Std. Option 521)	Semi-Rigid Cable, A24 20 GHz Highband Coupler (output)	3.5mm RF Output connector	E8251-20471

Replaceable Parts
Cables

Table 2-5 (Continued)

Reference Designator	Input	Output	Part Number
W146 (Option 521) (Option 1EM)	Semi-Rigid Cable, A24 20 GHz Highband Coupler (output)	3.5mm RF Output connector	E8251-20472
W147 (Option 521) (Option 1EM)	Semi-Rigid, A24 20 GHz Highband Coupler (output)	AT1 115 dB Mechanical Attenuator (input)	E8251-20474
W148 (E8663D and Option E8257D-520)	A30J6	A10J201	8120-6993
W149 (E8663D and Option E8257D-520)	A44J2 (Semi-Rigid Cable, AM MOD BIAS)	Semi-Rigid Cable, A29J2	E8251-20366
W150 (E8663D and Option E8257D-520)	Semi-Rigid Cable, A30J1	Semi-Rigid Cable, A44J5	E8251-20367
W151 (E8663D and Option E8257D-520)	Ribbon Cable, A44J1	A26J33	8121-1362
W152 (E8663D and Option E8257D-520)	Ribbon Cable, A44 Scan Modulation Bias Adapter	A44 Scan Modulation Bias Adapter	8121-0613
W153 (E8267D)	A31J1056	A31J1057	8121-1302
W154 (Option 1SM only)	A44J3	A10J301	8120-6993

- a. This cable is not replaceable by itself. You must order the corresponding assembly.
- b. For instruments with serial prefixes > US4805/MY4805. For instruments with serial prefixes < US4805/MY4805 this cable has one end connected to the rear panel, the other end is left disconnected and the whole cable is zip tied in a loop.
- c. Requires firmware version C.04.71 or greater.
- d. For instruments with serial prefixes < US4722/MY4722 you must replace all matched cables, W123 thru W126, the first time and order 4 SMA bulkhead adapters, part number 1250-1666.
- e. For instruments with serial prefixes < US4722/MY4722 you must replace all matched cables, W127 thru W130, the first time.
- f. For instruments with serial prefixes < US4722/MY4722 you must replace the two matched cables, W131 and W132, the first time.
- g. For instruments with serial prefixes ³ US4829/MY4829.

Hardware

This section lists part numbers for hardware and other instrument parts in your signal generator.

- “Front Panel View” on page 41
- “Disassembled Front Panel View” on page 43
- “Disassembled Rear Panel View” on page 45
- “Disassembled A32 10 MHz Crystal Oscillator (Option UNR/UNX/UNY and Instruments with Serial Prefixes \geq US4805/MY4805)” on page 48
- “Disassembled AT1 90dB/115dB Attenuator View (Option 1E1)” on page 50
- “Disassembled A24 20GHz/40GHz Highband Coupler and A25B Highband Detector Bias Board (Options 503, 509, 520, and 540)” on page 51
- “Disassembled A24 50GHz Highband Coupler and A25B Highband Detector Bias Board” on page 53
- “Disassembled A24 67GHz Highband Coupler and A25B Highband Detector Bias Board” on page 54
- “Microcircuit Interface Deck Top View” on page 55
- “Main Chassis and MID Bottom View” on page 56
- “1.85 mm RF Output Connector (Option 567 Only)” on page 59
- “2.4 mm RF Output Connector” on page 60
- “APC 3.5 RF Output Connector (Option 520 Only)” on page 61
- “Type-N RF Output Connector (Option 1ED Models Only)” on page 62
- “Main Chassis with Inside Cover and Right-Side Support Wall” on page 63
- “Outer and Inner Instrument Covers and Associated Parts” on page 65

Replaceable Parts
Hardware

Front Panel View

Table 2-6 Front Panel View

Item No.	Description	Qty	Part Number
1	Small Overlay (E8257D & E8663D Option UNM and All Option 1EM)	1	E4400-80011
	Small Overlay (E8267D) Option UNM	1	E4400-80006
2	Nameplate - E8257D 20 GHz	1	E8251-80027
	Nameplate - E8257D Option 521	1	E8251-80341
	Nameplate - E8257D 40 GHz	1	E8251-80028
	Nameplate - E8257D 50 GHz	1	E8251-80029
	Nameplate - E8257D 70 GHz	1	E8251-80030
	Nameplate - E8267D 20 GHz	1	E8251-80024
	Nameplate - E8267D 32 GHz	1	E8251-80025
	Nameplate - E8267D 44 GHz	1	E8251-80026
	Nameplate - E8663D 3 GHz	1	E8663-80001
	Nameplate - E8663D 9 GHz	1	E8663-80002
3	RPG Knob	1	E4400-40003
4	Large Keypad Overlay (E8257D & E8663D) Option UNM	1	E8251-80001
	Large Keypad Overlay (E8267D) Option UNM	1	E8251-80201
	Large Keypad Overlay (E8257D & E8663D) Option 1EM	1	E8251-80014
	Large Keypad Overlay (E8267D) Option 1EM	1	E8251-80202
5	Nut-Hex 15/32-32 E8257D & E8663D E8267D	7 12	2950-0035
	Washer-Wavy .490ID E8257D & E8663D E8267D	7 12	3050-1919
7	Washer-Shoulder	2	00310-48801
8	Bottom Overlay (Option UNM)	1	E8251-80003
	Bottom Overlay (Option 1EM)	1	E8251-80203

Figure 2-16 Front Panel View

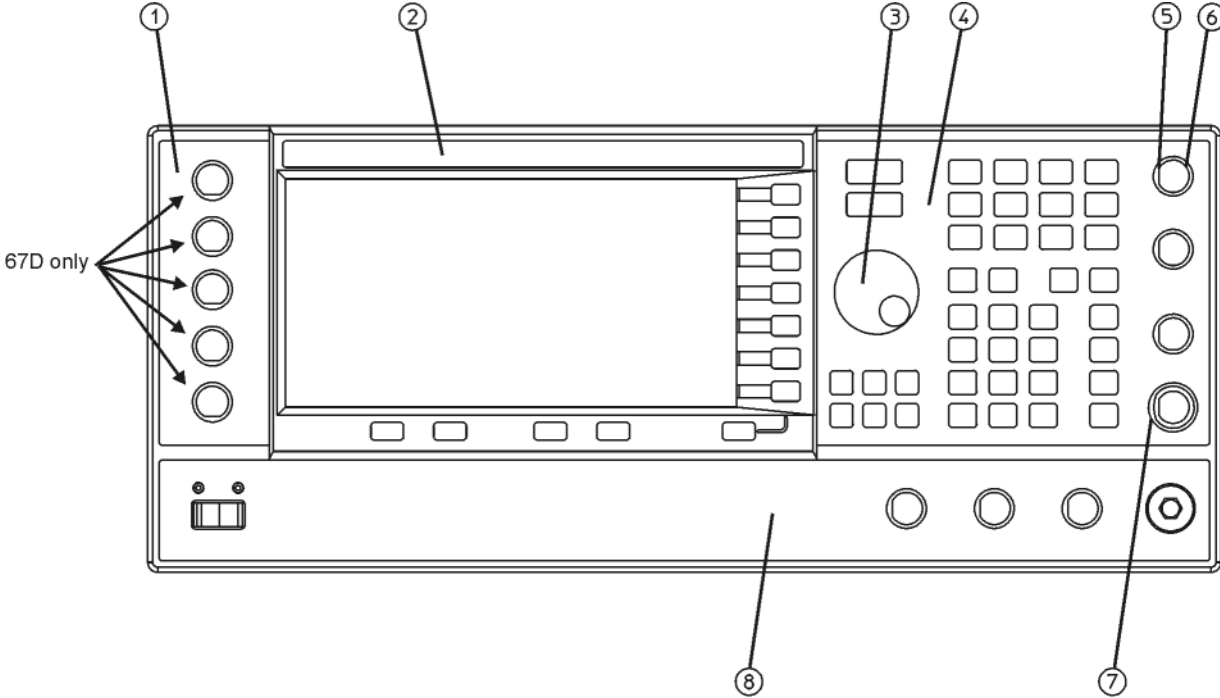

Replaceable Parts
Hardware

Disassembled Front Panel View

Table 2-7 Disassembled Front Panel View

Item No.	Description	Qty	Part Number
1	Front Panel Frame	1	E8251-20102
2	Gasket RFI Round Mesh .125 inch	1	8160-0660
3	Gasket RFI Round Mesh .062 inch	1	8160-0723
4	Velcro Attachment	1	0510-1303
5	Glass Filter 70% Xmt	1	4330-6704
6	Rubber Keypad Analog (E8257D & E8663D)	1	E8251-40006
	Rubber Keypad Vector (E8267D)	1	E8251-40200
7	Bracket Filter	1	E4400-00009
8	Screw-Machine M3.0 x 08 FL-TX	14	0515-1227
9	Cable Retainer Clip	3	1400-1439
10	Sub Panel	1	E8251-00009
11	Screw-Machine M3.0 x 06 CW-PN-TX	17	0515-0372
12	Screw-Machine M3.0 x 08 FL-TX	1	0515-1035

Figure 2-17

Disassembled Front Panel View

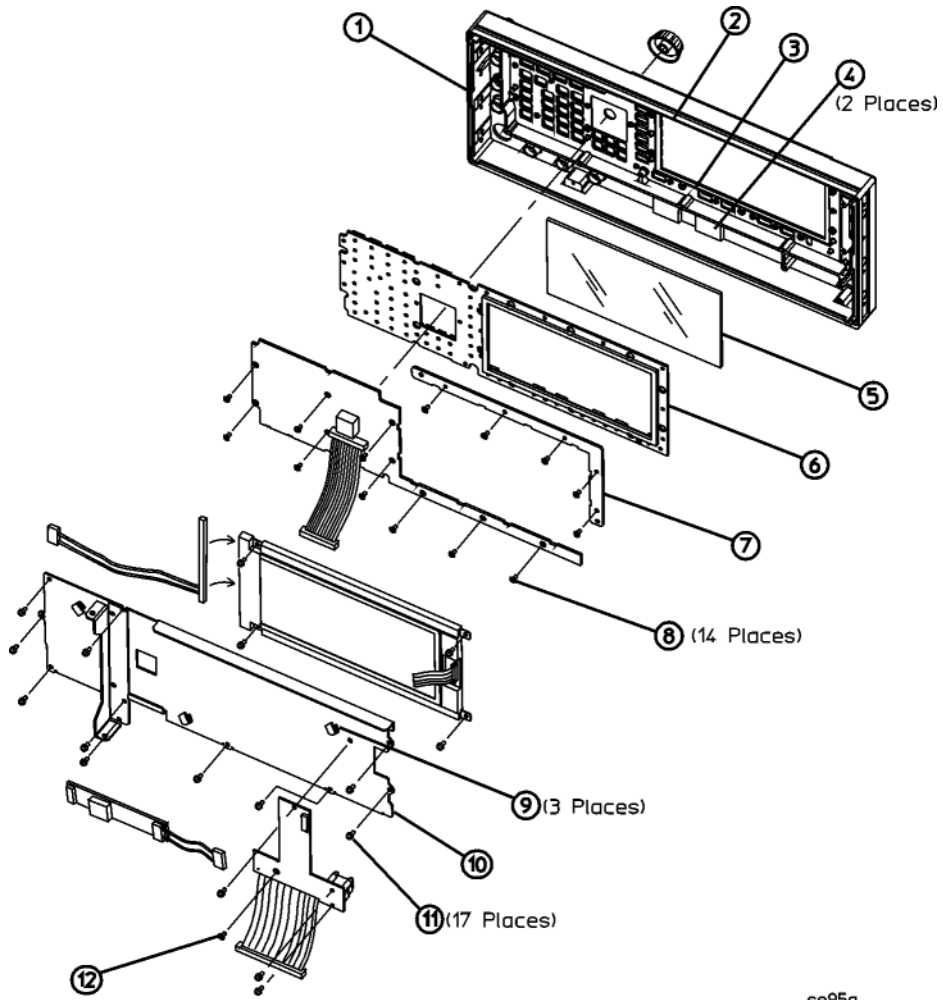

se95a

Replaceable Parts
Hardware

Disassembled Rear Panel View

Table 2-8 Disassembled Rear Panel View

Item No.	Description	Qty	Part Number
1	Rear Panel (E8257D & E8663D)	1	E8251-00020
	Rear Panel (E8257D & E8663D) Option 1EM	1	E8251-00013
	Rear Panel (E8267D)	1	E8251-00021
	Rear Panel (E8267D) Option 1EM	1	E8251-00022
2	Screw-Machine M3.0 8 CW-PN-TX (mounting screws for rear-panel and rear struts) E8257D & E8663D E8267D	11	0515-0372
		14	
3	Screw-Machine M3.0 14CW-PN-TX (screw to mount B1 fan to rear-panel)	4	0515-0665
4	Beveled Washer (fan)	4	3050-1628
5	Grommet (fan)	4	0400-0356
6	Nut-Hex 1/2-28 (6 BNC connectors on rear-panel board)	6	2950-0054
7	Washer Lock .505ID (6 BNC connectors on rear-panel)	6	2190-0068
8	Nut-Hex 15/32-32 (10 MHz In/Out BNC connectors) E8257D & E8663D E8267D	9	2950-0035
		26	
9	Washer .490ID (10 MHz In/Out BNC connectors) E8257D & E8663D E8267D	9	3050-1919
		26	
10	Rear-Panel BNC Hole Plug (E8267D)	1	6960-0002
11	Standoff Screw-Hex .321 4-40ss (Auxiliary Interface and SMI) E8257D & E8663D E8267D	4	0380-2079
		6	
12	Split Lock Washer .115ID 4 (Auxiliary Interface and SMI) E8257D & E8663D E8267D	4	2190-0003
		6	
13	Standoff Screw-Hex .327 6-32 (GPIB interface)	2	0380-0644
14	Split Lock Washer .194ID 10 (GPIB interface)	2	2190-0577
15	Screw-Machine M3.0 8 FL-TX (line module)	2	0515-1035
16	Right Rear Strut (E8257D & E8663D)	1	E8251-00006
	Right Rear Strut (E8267D)	1	E8251-00308
17	Left Rear Strut (E8257D & E8663D)	1	E8251-00030
	Left Rear Strut (E8267D)	1	E8251-00200

Table 2-8 Disassembled Rear Panel View

Item No.	Description	Qty	Part Number
18	Shouldered Washer (E8267D)	1	00310-48801

Figure 2-18 E8257D/E8663D Disassembled Rear Panel View

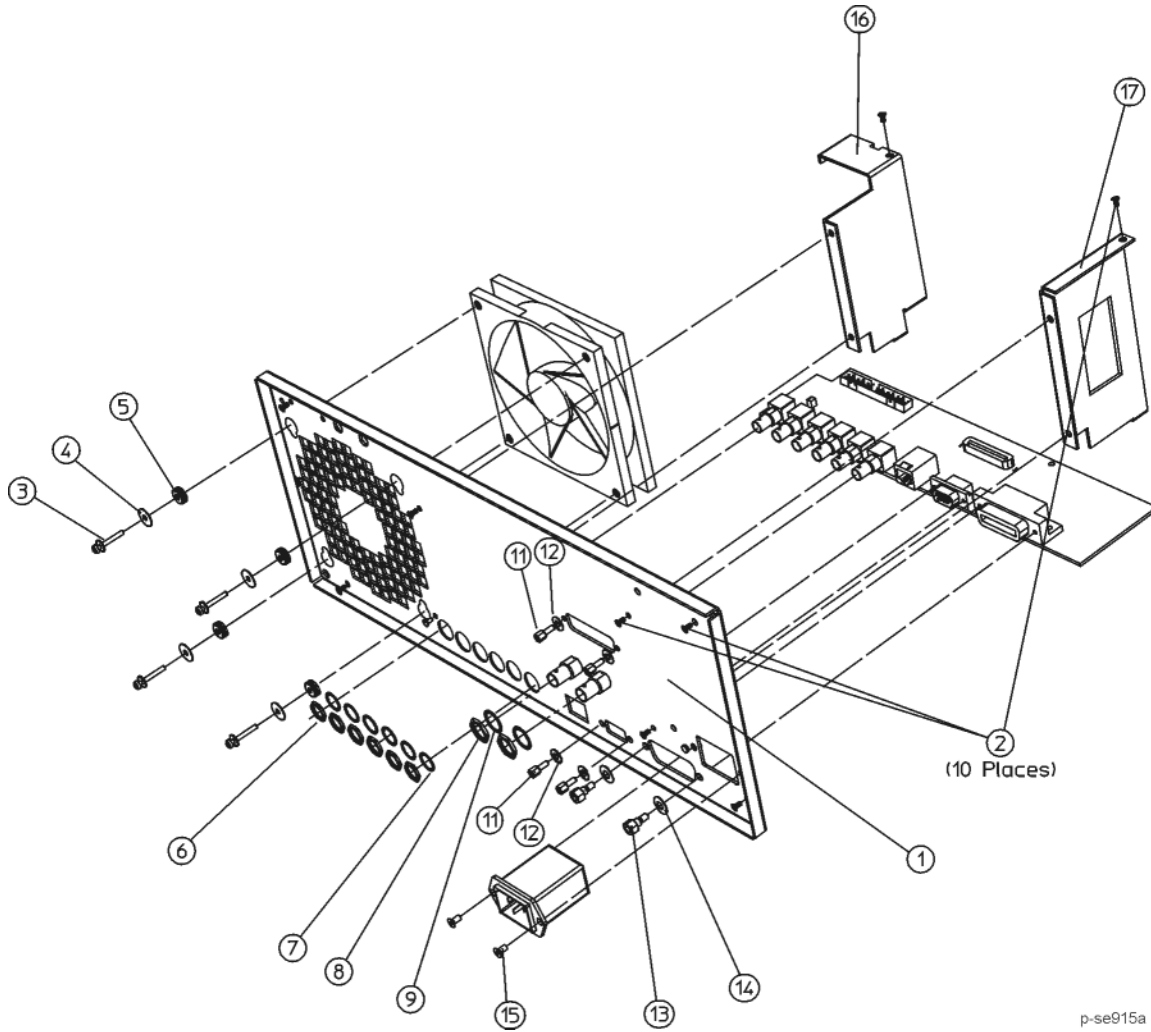
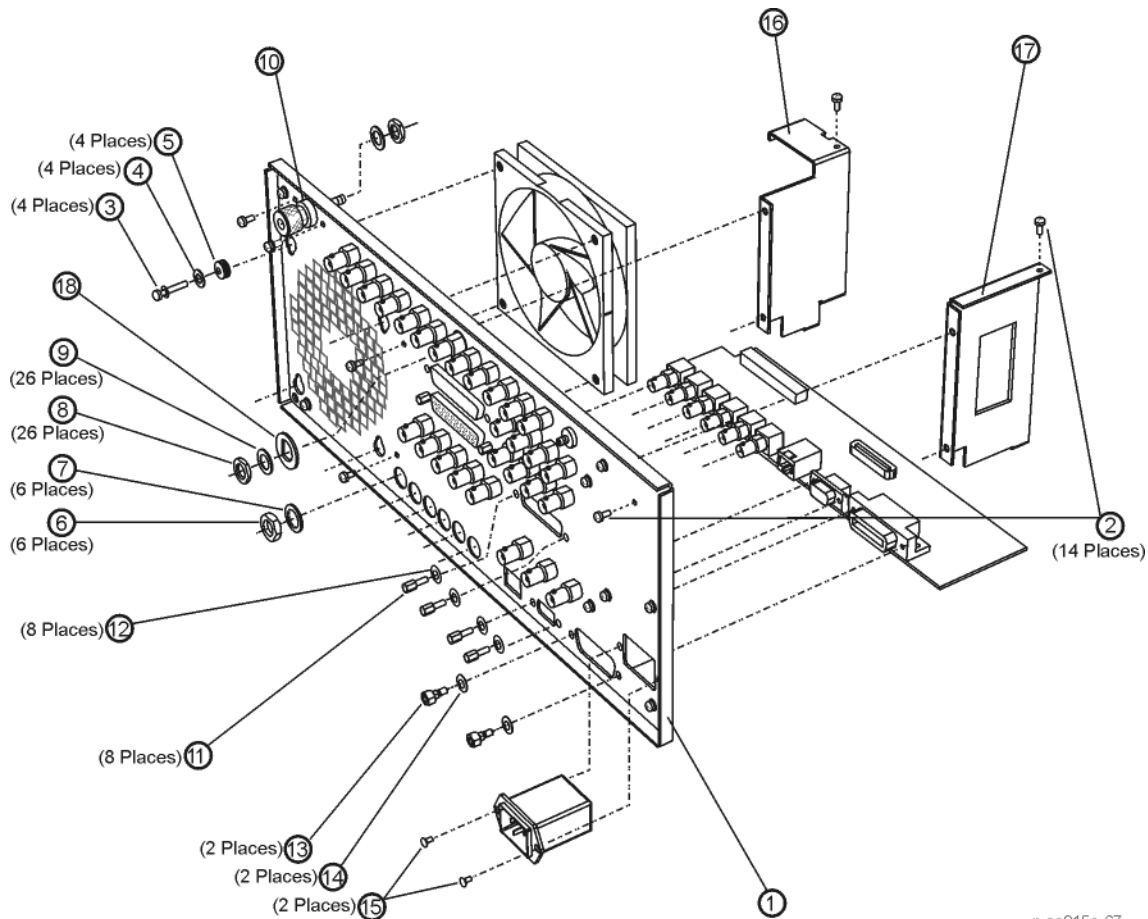

Figure 2-19 E8267D Disassembled Rear Panel View



p-se915a-67

Replaceable Parts
Hardware

Disassembled A32 10 MHz Crystal Oscillator (Option UNR/UNX/UNY
and Instruments with Serial
Prefixes >= US4805/MY4805)

Table 2-9 Disassembled A32 10 MHz Crystal Oscillator (Option UNR/UNX)

Item No.	Description	Qty	Part Number
1	C-Bracket	1	E8251-00040
2	Shock Mount	3	1520-0205
3	Flathead Washer	3	3050-0105
4	Screw-Machine 4.0 x 40 .250	3	2200-0103
5	L-Bracket	1	E8251-00041
6	Screw-Machine M3.0 x 8 CW-PN-TX	2	0515-0372
7	Nut-Hex M3.0 (line module ground)	1	0535-0031
8	Screw-Machine M3.0 x 8 CW-PN-TX	2	0515-0372

Figure 2-20

Disassembled A32 10 MHz Crystal Oscillator (Option UNR/UNX and Instruments with Serial Prefixes > US4805/MY4805)

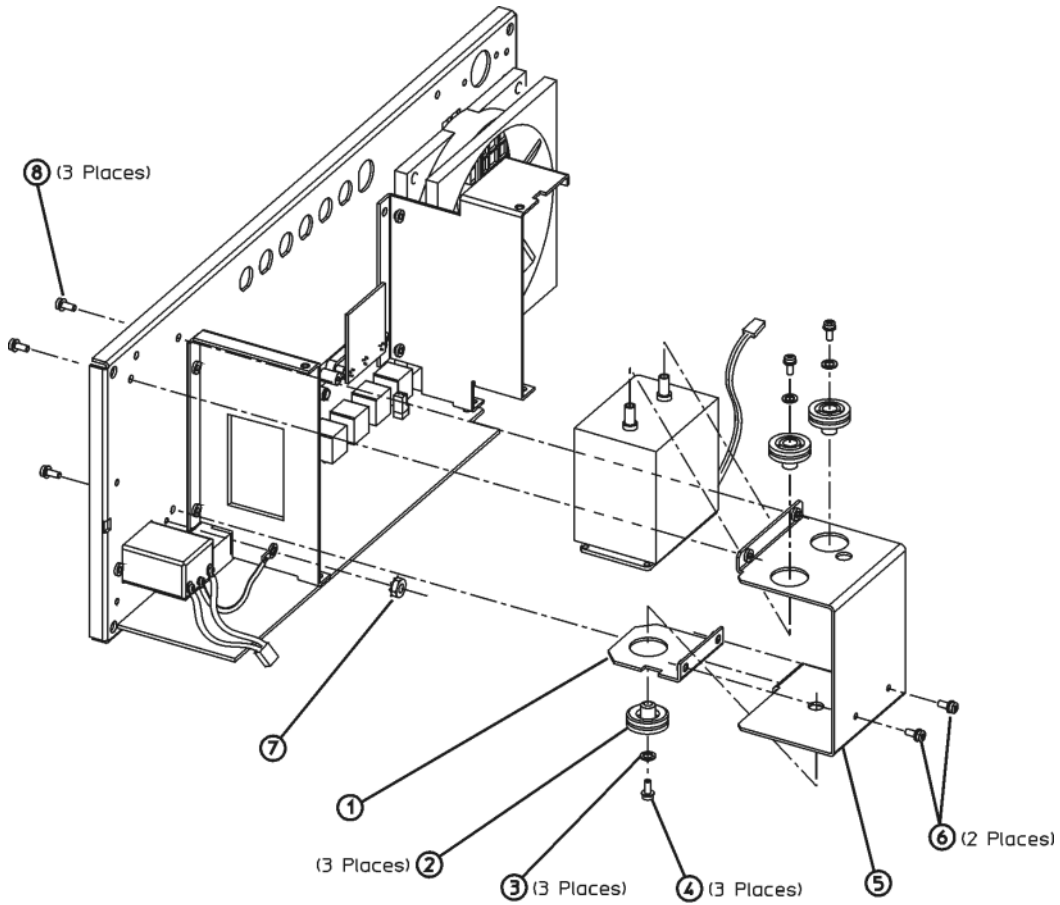

p-se925a

Disassembled AT1 90dB/115dB Attenuator View (Option 1E1)

Table 2-10 Disassembled AT1 115 dB Attenuator View (Option 1E1)

Item No.	Description	Qty	Part Number
1	Bracket	1	E8251-00038
2	Screw-Machine M3.0 x 8 FL-TX	4	0515-1035

Figure 2-21 Disassembled AT1 90dB/115dB Attenuator View (Option 1E1)

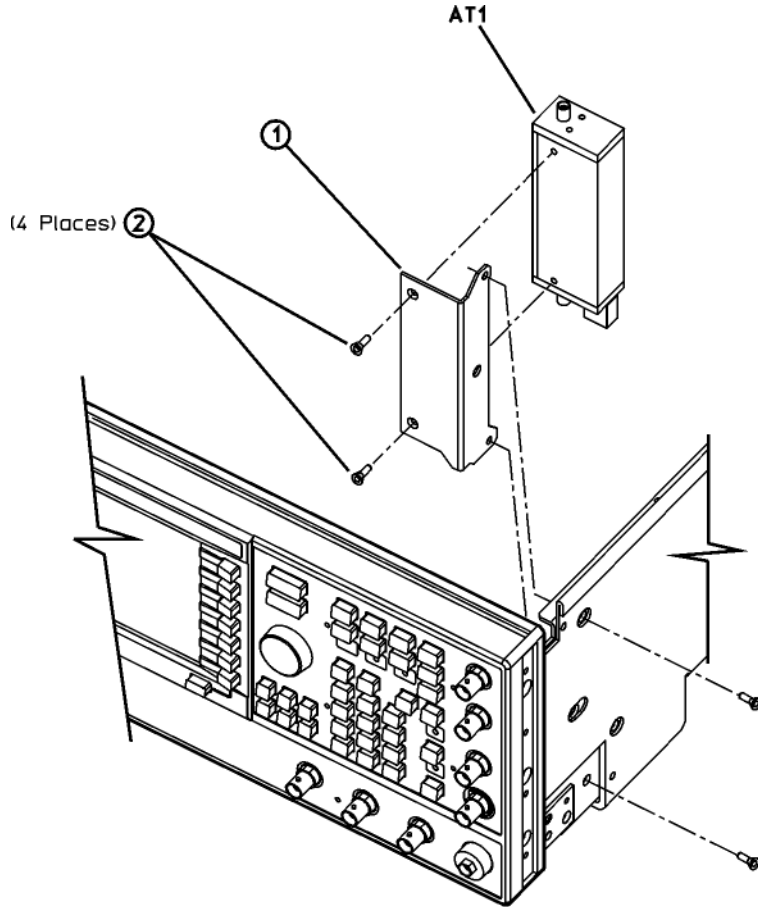

se941a

Disassembled A24 20GHz/40GHz Highband Coupler and A25B
Highband Detector Bias Board
(Options 503, 509, 520, and 540)

Table 2-11 Disassembled A24 20 GHz/40 GHz Highband Coupler and A25B Highband Detector Bias Board

Item No.	Description	Qty	Part Number
1	Coupler Bracket	1	E8251-00039
2	Washer Lock M2.0	2	2190-0654
3	Screw-Machine SM 256 .250 PN-PN	2	0520-0128
4	Screw-Machine M3.0 x 8 CW-PN-TX	4	0515-0372

Figure 2-22 Disassembled A24 20GHz/40GHz Highband Coupler and A25B Highband Detector Bias Board

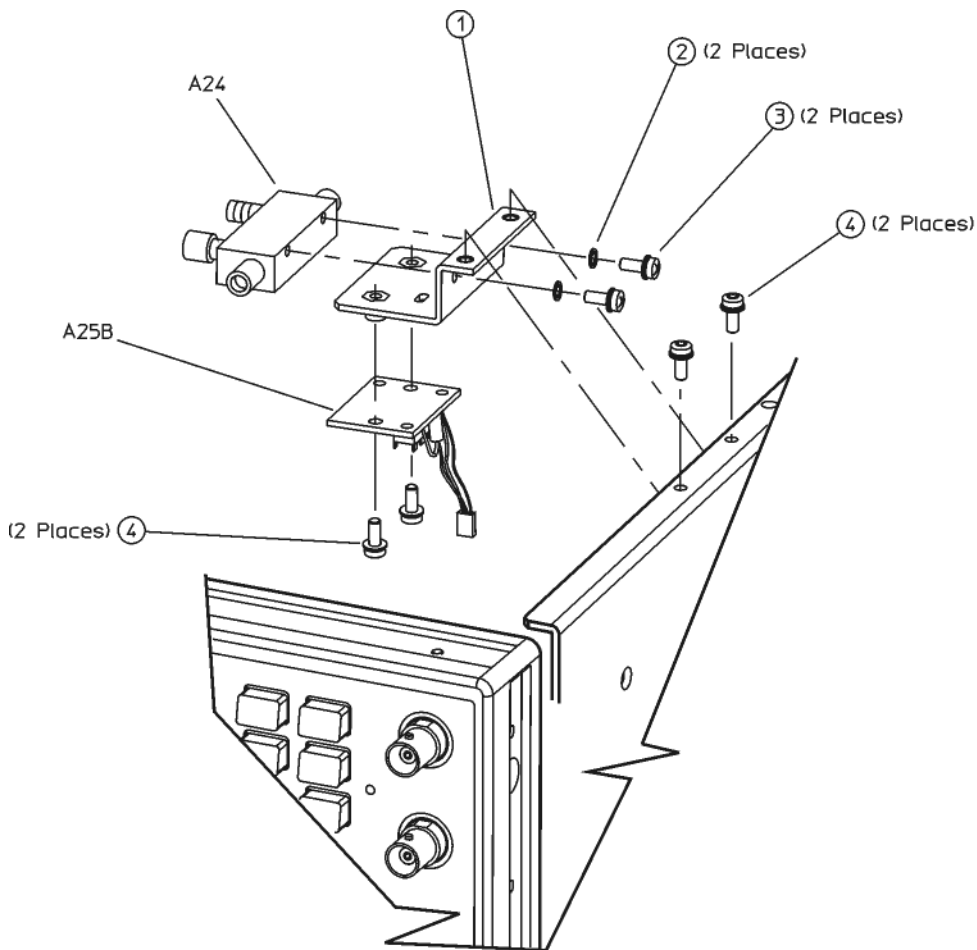

se923a

Disassembled A24 20GHz Highband Coupler and A25B Highband Detector Bias Board (Option 521)

Table 2-12 Disassembled A24 67GHz Highband Coupler and A25 Highband Detector

Item No.	Description	Qty	Part Number
1	Coupler Bracket (Option 521)	1	E8251-00356
2	Screw-Machine M4.0 x .312 PN-PN	2	0520-0128
3	Screw-Machine M3.0 x 8 CW-PN-TX	6	0515-0372

Figure 2-23 Disassembled A24 20GHz Highband Coupler and A25B Highband Detector Bias Board (Option 521)

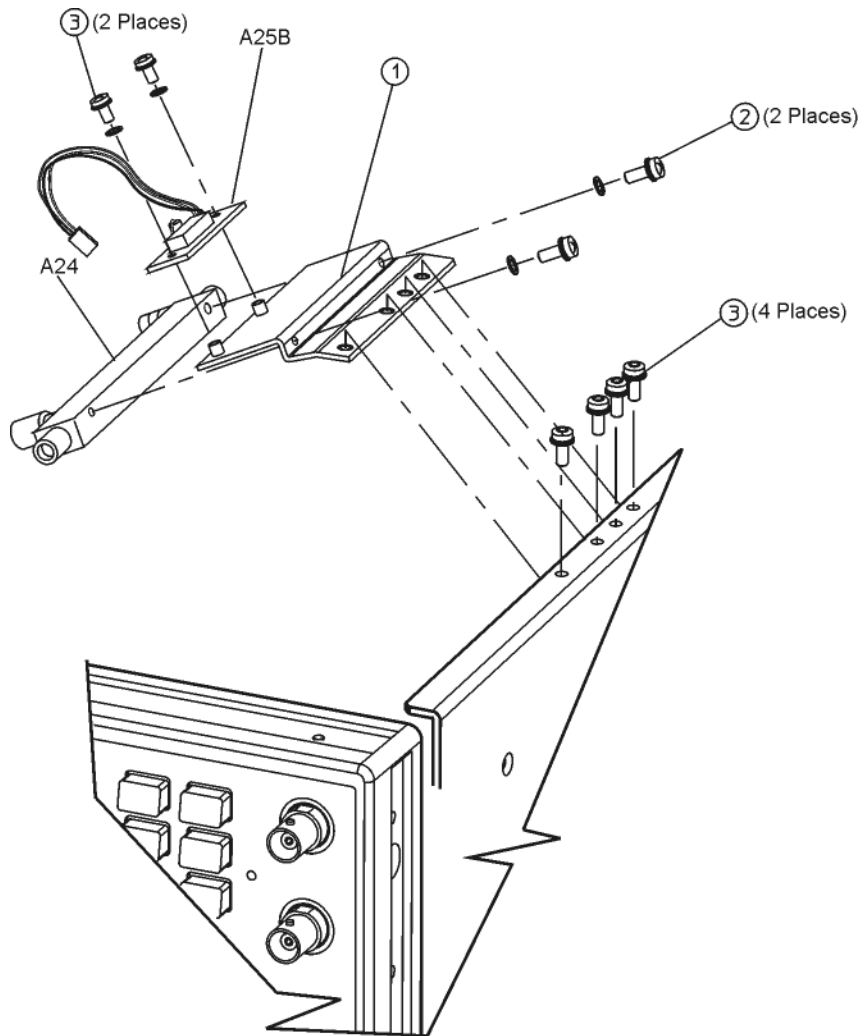

Disassembled A24 50GHz Highband Coupler and A25B Highband Detector Bias Board

Table 2-13 Disassembled A24 50GHz Highband Coupler and A25 Highband Detector

Item No.	Description	Qty	Part Number
1	Coupler Bracket (Option 532/544)	1	E8251-00300
2	Screw-Machine M4.0 x .312 PN-PN	2	2200-0103
3	Screw-Machine M3.0 x 8 CW-PN-TX	4	0515-0372

Figure 2-24 Disassembled A24 50GHz Highband Coupler and A25B Highband Detector Bias Board

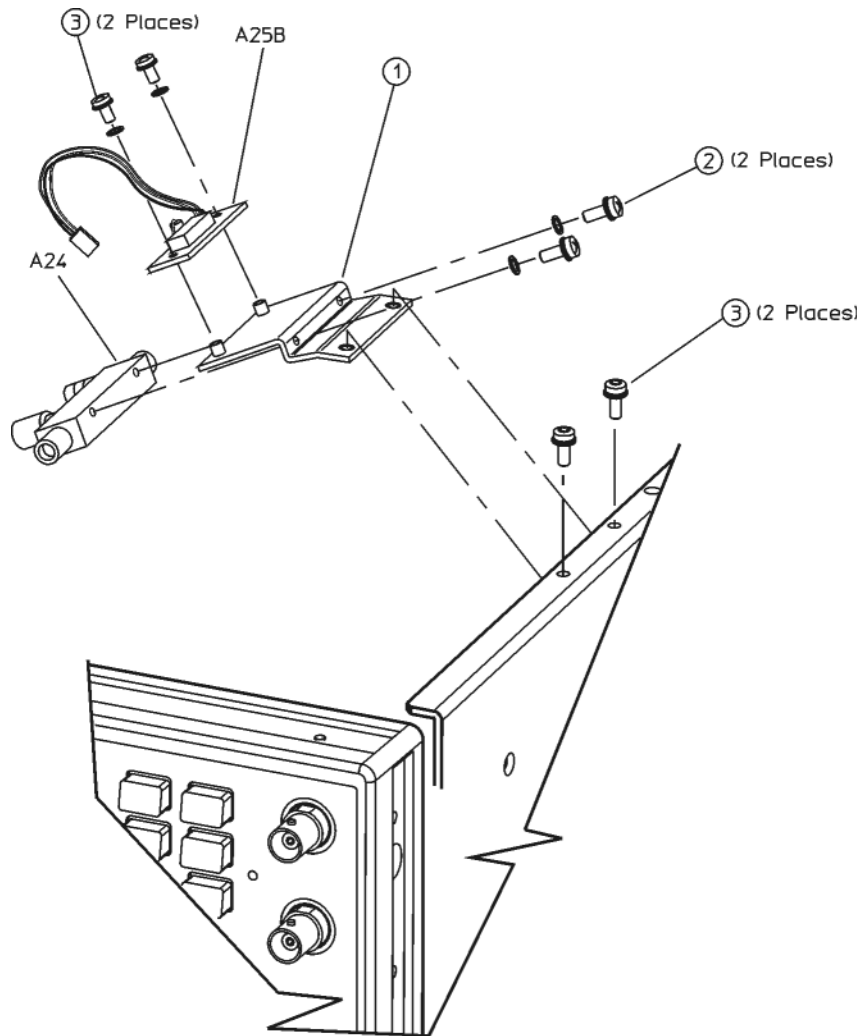

Disassembled A24 67GHz Highband Coupler and A25B Highband Detector Bias Board

Table 2-14 Disassembled A24 67GHz Highband Coupler and A25 Highband Detector

Item No.	Description	Qty	Part Number
1	Coupler Bracket (Option 550/567)	1	E8251-00306
2	Screw-Machine M4.0 x .312 PN-PN	2	0515-0658
3	Screw-Machine M3.0 x 8 CW-PN-TX	4	0515-0372

Figure 2-25 Disassembled A24 67GHz Highband Coupler and A25B Highband Detector Bias Board

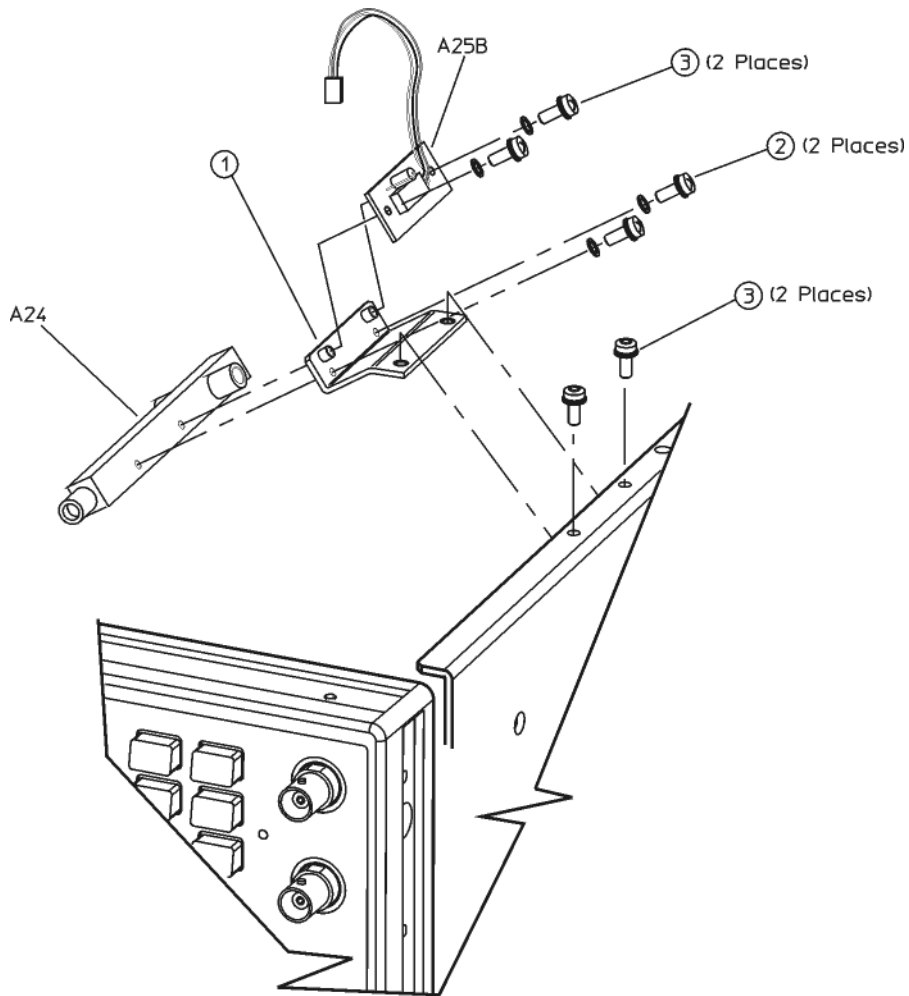

Microcircuit Interface Deck Top View

Table 2-15 Microcircuit Interface Deck Top View

Item No.	Description	Qty	Part Number
1	Screw-Machine M3.0 x 14 CW-PN-TX	1	0515-0665

Figure 2-26 E8257D & E8663D Microcircuit Interface Deck Top View

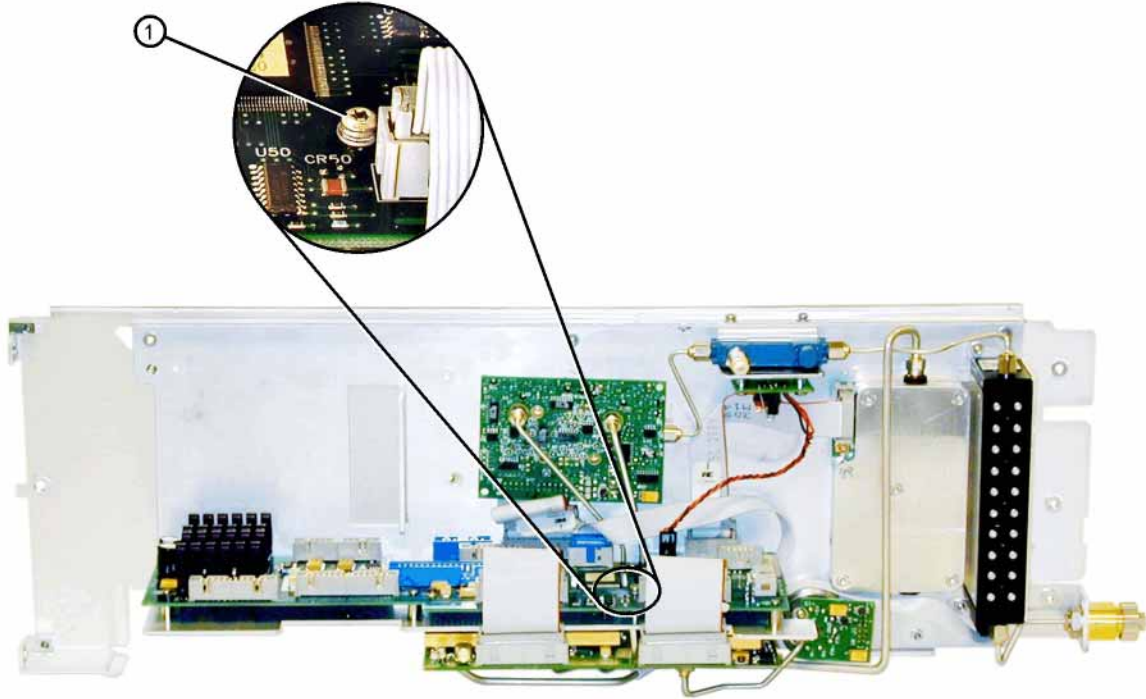

se955a

Figure 2-27 E8267D Microcircuit Interface Deck Top View



p2_a26

Replaceable Parts
Hardware

Main Chassis and MID Bottom View

Table 2-16 Main Chassis and MID Bottom View

Item No.	Description	Qty	Part Number
1	Rib Bracket	1	E8251-00008
2	Cable Retainer Clip E8257D & E8663D E8267D	3 8	E8251-40001
3	Screw-Machine M30. x 8 CW-PN-TX (A31 Motherboard to main chassis)	15	0515-0372
4	Screw-Machine M30. x 8 CW-PN-TX (A28 YIG Oscillator to MID)	2	0515-0372
5	Screw-Machine M30. x 20 CW-PN-TX (A30 Modulator Filter with Standard or High Power to MID)	3	0515-1410
6	Screw-Machine M30. x 20 CW-PN-TX (A29 20 GHz Doubler to MID)	2	0515-1410
7	Screw-Machine M30. x 20 CW-PN-TX (A13 I/Q MUX to MID) (E8267D)	3	0515-1410

Figure 2-28

Main Chassis and MID Bottom View (E8257D & E8663D)

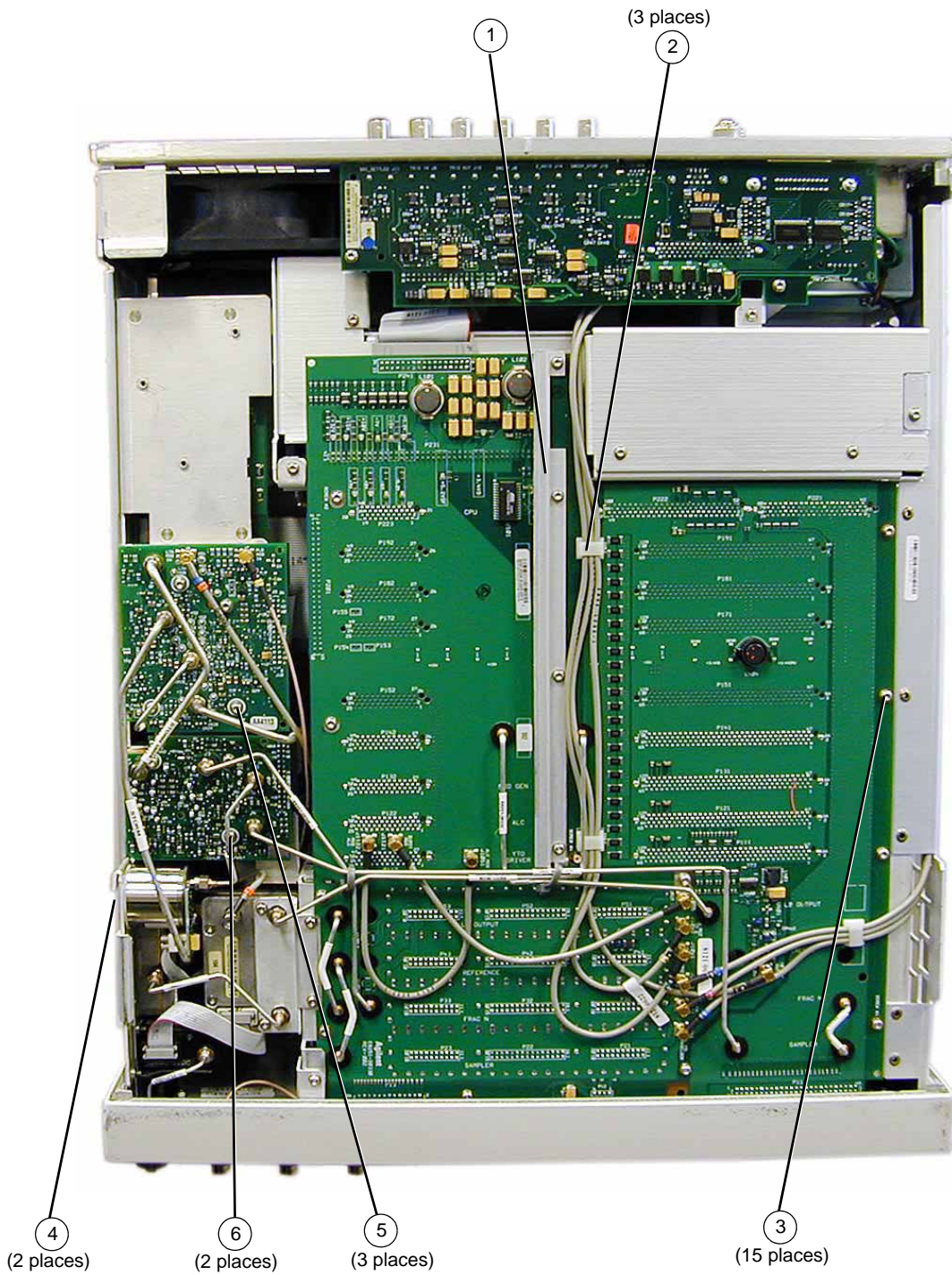
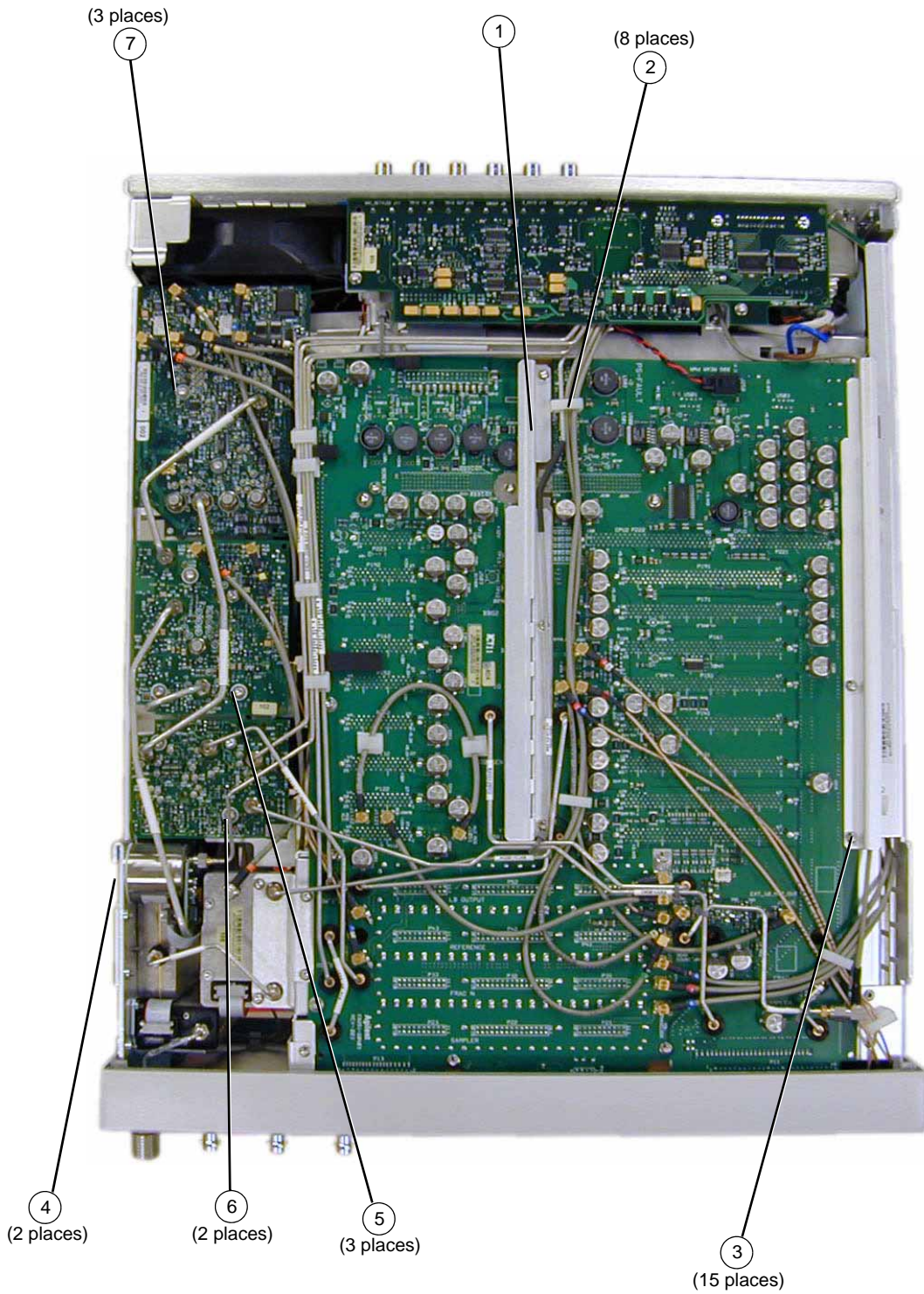

Figure 2-29 Main Chassis and MID Bottom View (E8267D)



1.85 mm RF Output Connector (Option 567 Only)

Table 2-17 1.85 mm RF Output Connector (Option 567 Only)

Item No.	Description	Qty	Part Number
1	Adapter-Male 1.85 mm	1	5065-9852
2	Adapter Bracket	1	E8251-00216
3	Screw-Machine M4.0 x 10 FL-TX (front frame to adapter bracket)	1	0515-1269
4	Washer lock .377ID	1	2190-0104
5	Nut-Hex	1	2950-0132
	W92 Semi-Rigid Cable (refer to Table 2-5 on page 30.)		

Figure 2-30 1.85 mm RF Output Connector (Option 567 Only)

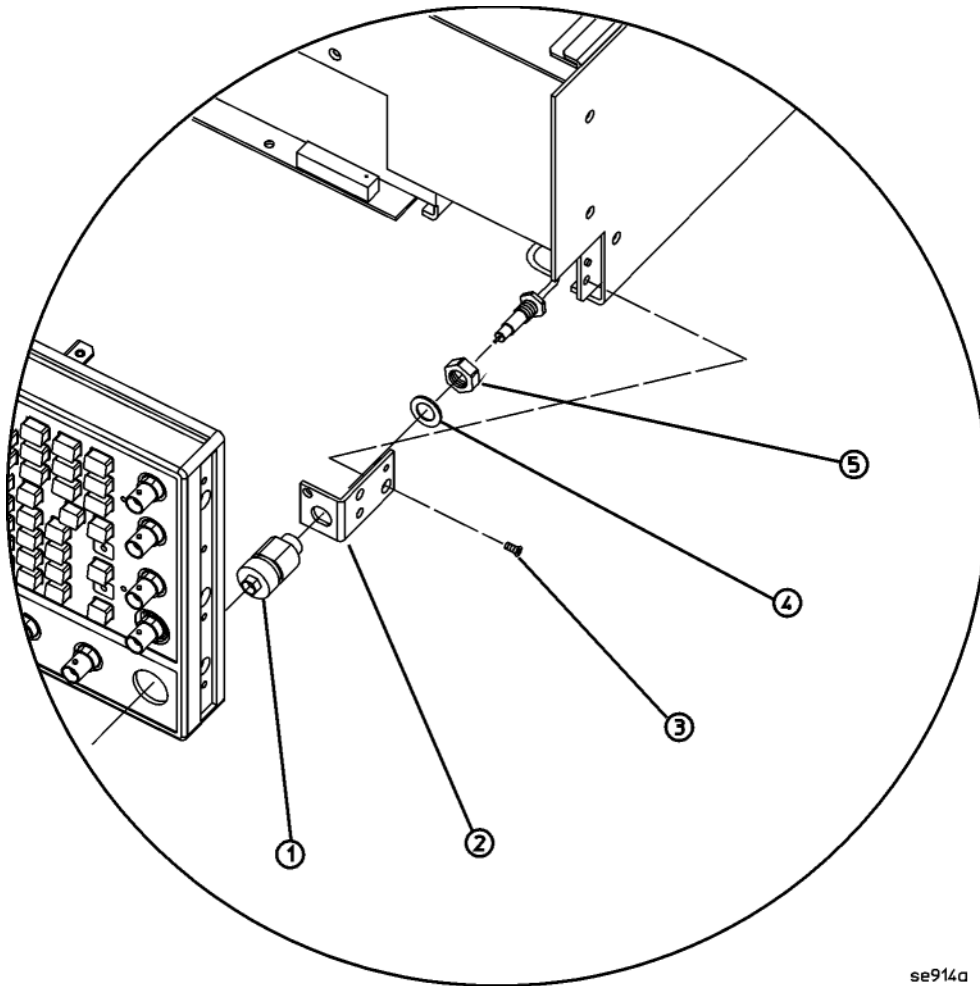

se914a

2.4 mm RF Output Connector

Table 2-18 2.4 mm RF Output Connector

Item No.	Description	Qty	Part Number
1	Adapter-Male 2.4 mm	1	5063-1700
2	Adapter Bracket	1	E8251-00216
3	Screw-Machine M4.0 x 10 FL-TX (front frame to adapter bracket)	1	0515-1269
4	Washer lock .377ID	1	2190-0104
5	Nut-Hex	1	08360-20133

Figure 2-31 2.4 mm RF Output Connector

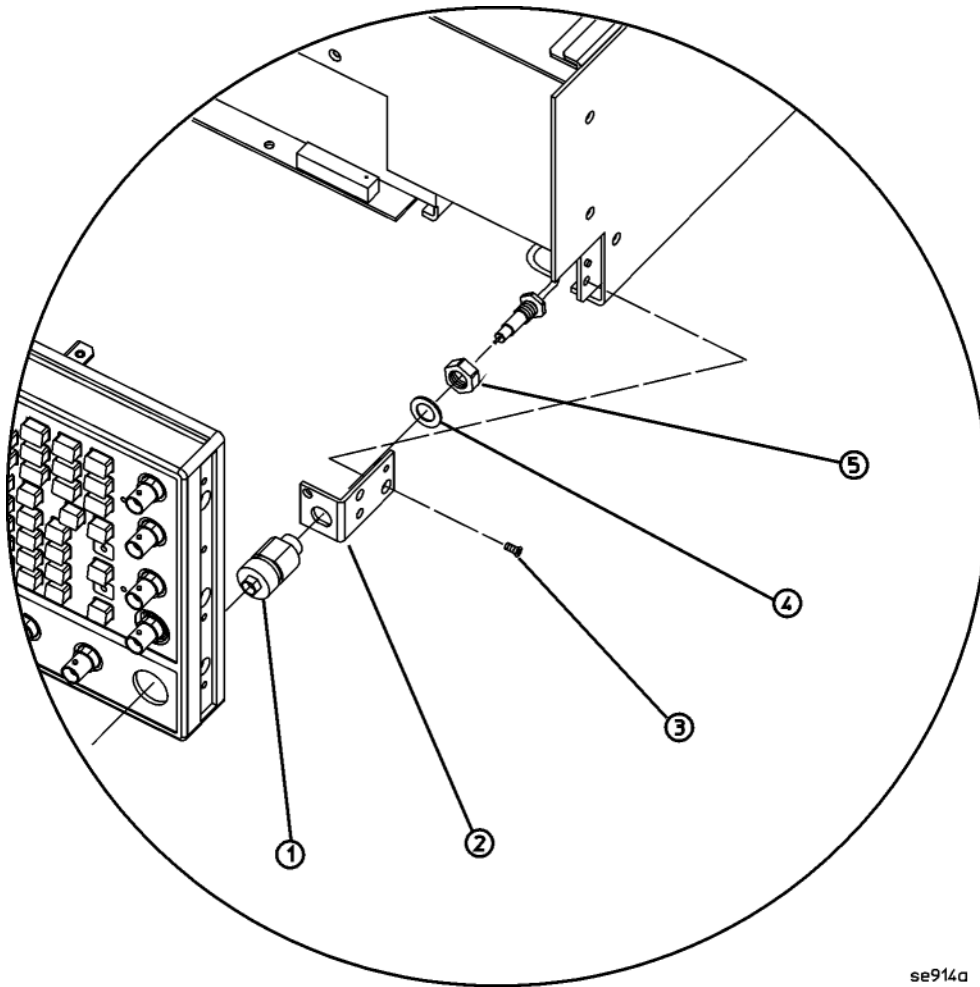

se914a

APC 3.5 RF Output Connector (Option 520 Only)

Table 2-19 APC 3.5 RF Output Connector (Option 520 Only)

Item No.	Description	Qty	Part Number
1	Adapter-Male APC 3.5	1	08673-60040
2	Spacer APC 3.5	1	E8251-20068
3	Adapter Bracket	1	E8251-00215
4	Screw-Machine M4.0 x 10 FL-TX	1	0515-1269
5	Washer lock .377ID	1	2190-0016
6	Nut-Hex	1	2950-0001
	W86 Semi-Rigid Cable (refer to Table on page 30.)		

Figure 2-32 APC 3.5 RF Output Connector (Option 520 Only)

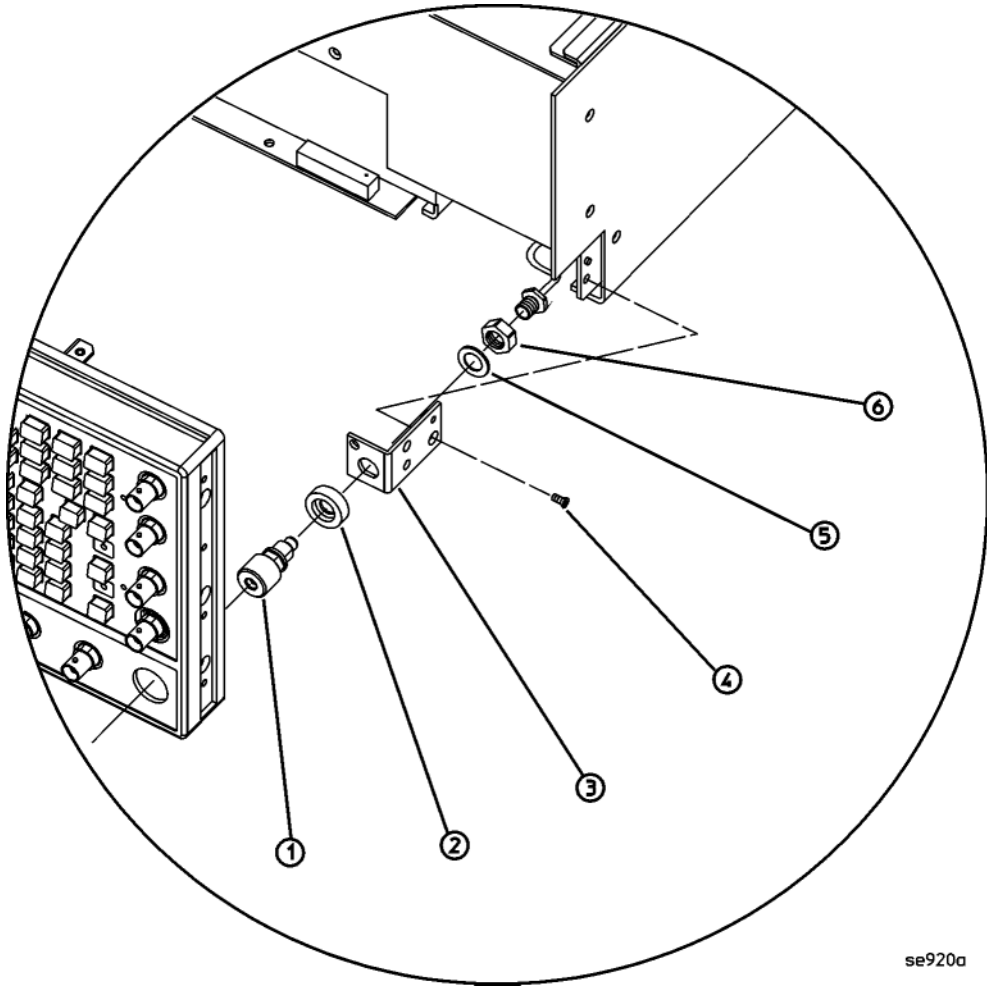

Type-N RF Output Connector (Option 1ED Models Only)

Table 2-20 Type-N RF Output Connector (Option 1ED Models Only)

Item No.	Description	Qty	Part Number
1	Adapter-Type-N (f)	1	08559-60002
2	Spacer	1	E8251-20067
3	Adapter Bracket	1	E8251-00216
4	Screw-Machine M4.0 x 10 FL-TX	1	0515-1035
5	Washer lock	1	2190-0102
6	Nut-Hex	1	2950-0132

Figure 2-33 Type-N RF Output Connector (Option 1ED Models Only)

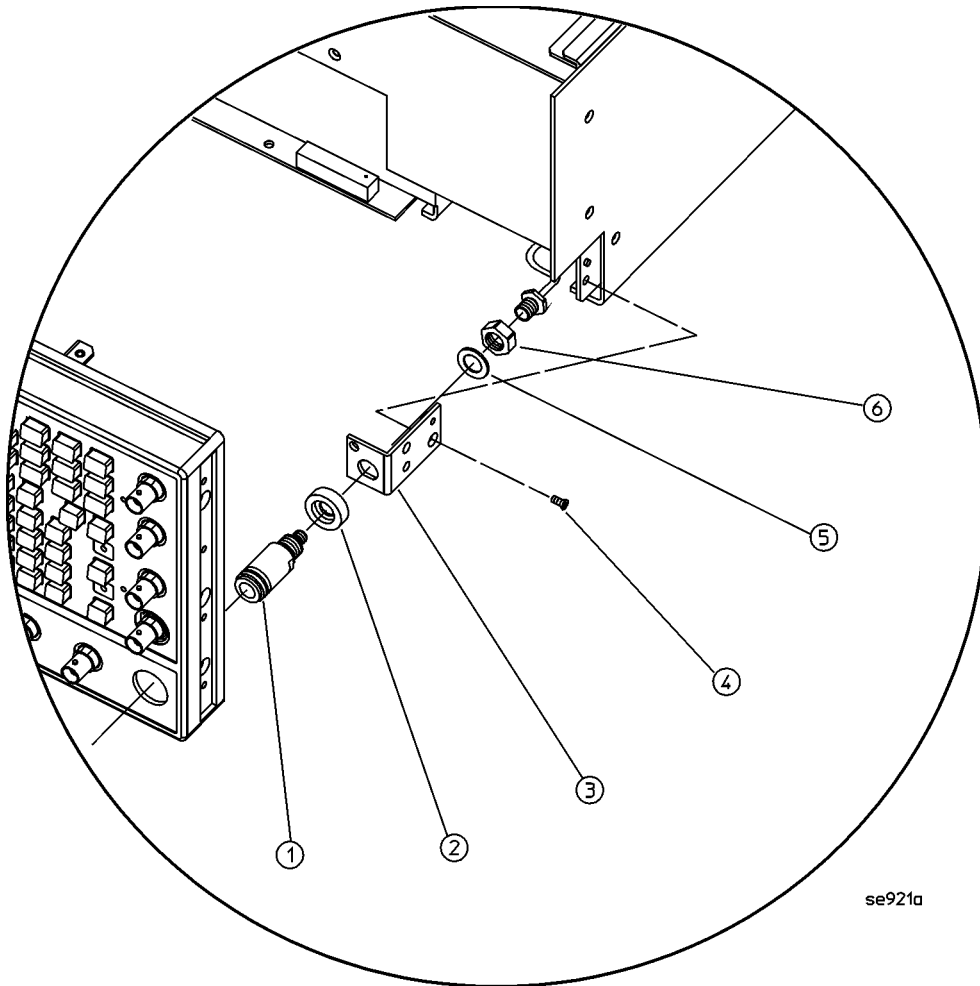

se921a

Main Chassis with Inside Cover and Right-Side Support Wall

Table 2-21 Main Chassis with Inside Cover and Right-Side Support Wall

Item No.	Description	Qty	Part Number
1	Main Chassis Inside Top Cover (E8257D & E8663D)	1	E8251-00342
	Main Chassis Inside Top Cover (E8267D)	1	E8251-00208
2	Screw-Machine M3.0 x 08 FL-TX (inside top cover to main chassis and rear panel)	9	0515-0430
3	Screw-Machine M3.0 x 08 CW-PN-TX (rear panel to right-side support wall)	3	0515-0372
4	Screw-Machine M3.0 x 08 FL-TX (microcircuit interface deck to right-side support wall)	6	0515-1035
5	Right-Side Support Wall	1	E8251-00014
6	Microcircuit Interface Deck (E8257D (E8663D)	1	E8251-00004
	Microcircuit Interface Deck (E8267D)	1	E8251-00303
7	E8257D & E8663D Main Chassis	1	E8251-60354
	E8267D Main Chassis	1	E8251-60350

Figure 2-34 Main Chassis with Inside Cover and Right-Side Support Wall

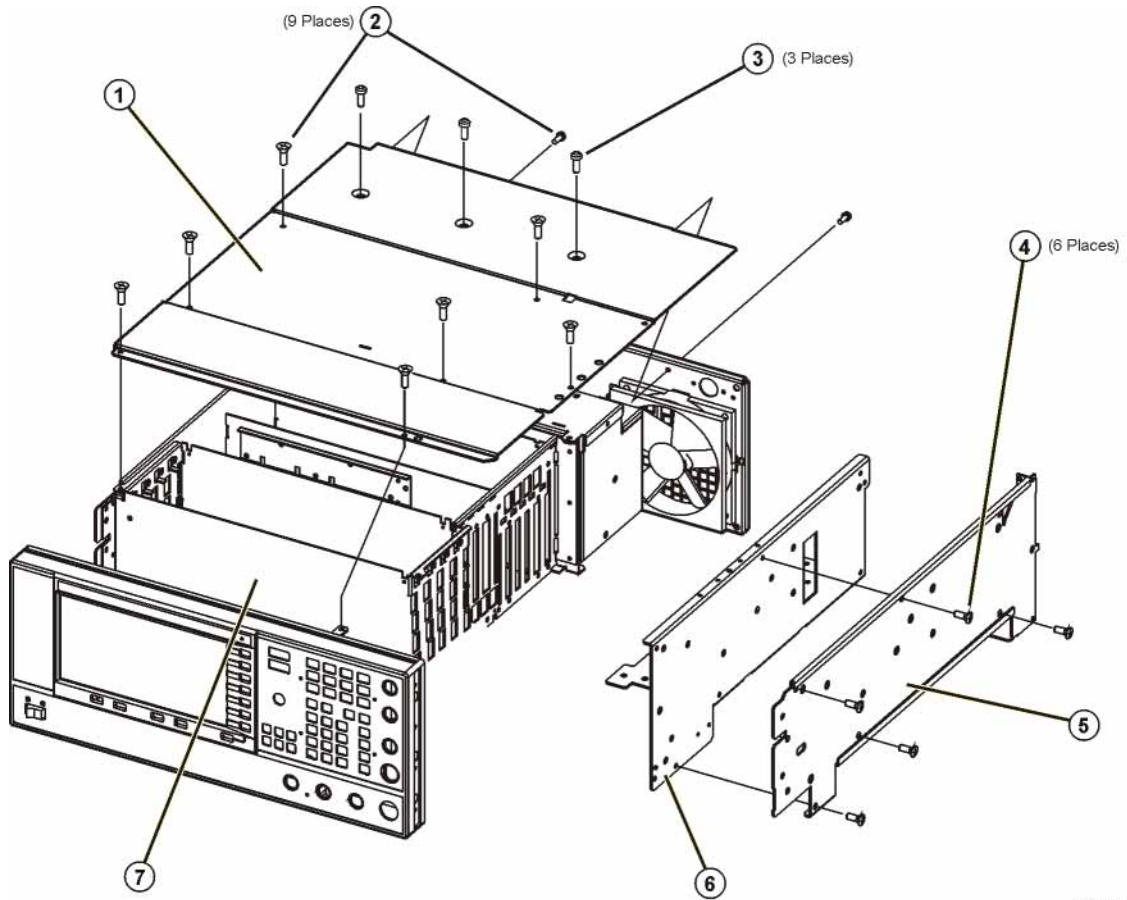

p-se931a

Outer and Inner Instrument Covers and Associated Parts

Table 2-22 Outer and Inner Instrument Covers and Associated Parts

Item No.	Description	Qty	Part Number
1	Assy-Strap Handle - includes the following parts:	1	E8251-60067
	Strap Assembly	1	
	Ground Spring	2	
	Handle Retainer	2	
	End Cap	2	
	Screw-Machine M5 x 18 FL-TX	2	
2	Rear Feet Screws	4	0515-1619
3	Rear-Panel Feet	4	5041-9611
4	Feet-Bottom	4	5041-9167
5	Tilt Stand	2	1460-1345
6	Trim-Side Overlay (Refer to Figure 2-35 and to Figure 2-36 on page 66)	2	5041-9172
7	Outside Instrument Cover	1	E8251-00012

Figure 2-35 Outer and Inner Instrument Covers and Associated Parts

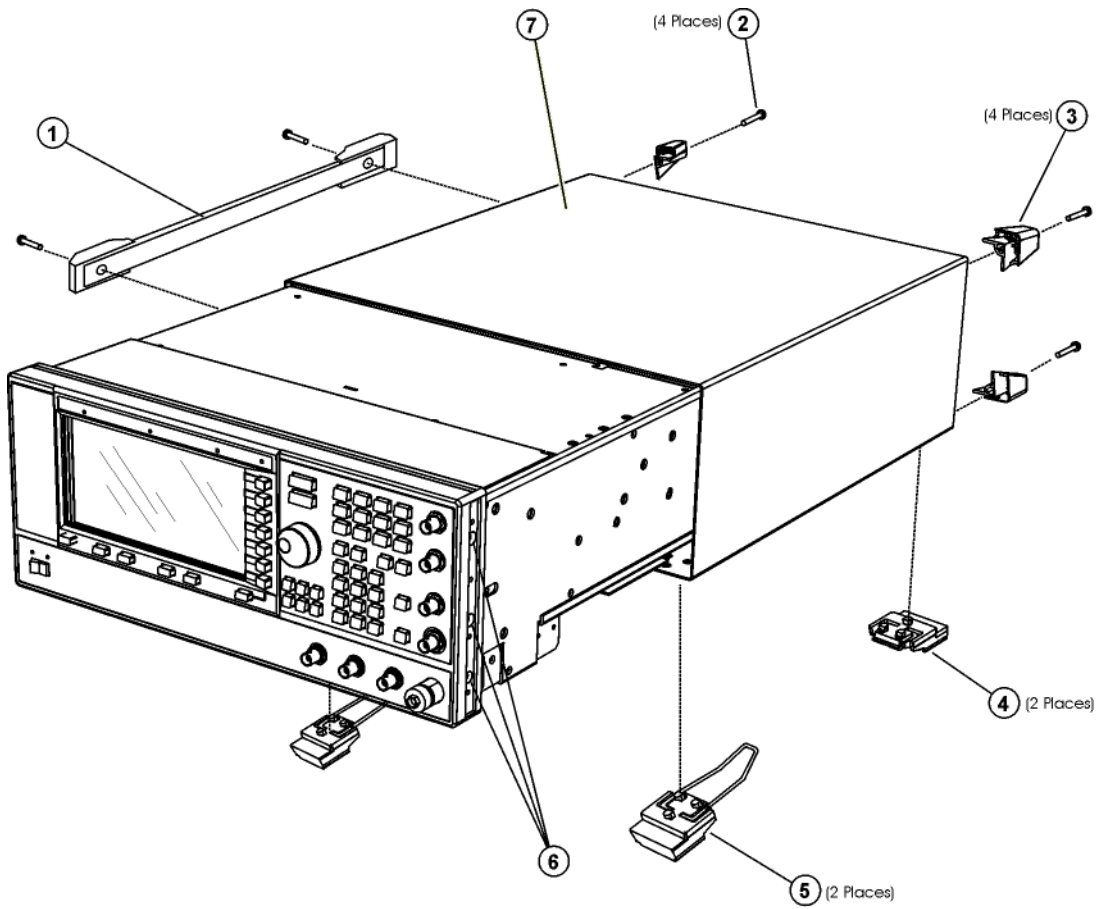

se92a

Figure 2-36 Trim-Side Overlay (Installed)



Miscellaneous

This section lists part numbers for miscellaneous items that can be used with your signal generator.

Accessories

Table 2-23 Accessories

Description	Part Number
Test Cable (extension cable for accessing A31 Motherboard coax connectors)	E8251-20088
Adapter 2.4 mm (F) - 2.4 mm (F)	33311-82005
Adapter-Coax STR F 2.4 mm (F) - K	1250-2187
Adapter 3.5 mm (F) - Type-N (M)	1250-1744
Adapter 1.85 mm (F) - 1.85 mm (F)	85085-60114
Adapter 3.5 mm (F) - 3.5 mm (F)	5061-5311

Documentation

Table 2-24 Documentation

Description	Part Number
PSG Documentation Set	E8251-90350
CD-ROM Documentation	E8251-90351
Installation Guide	E8251-90352
User's Guide	E8251-90353
Key Reference	E8251-90354
Programming Guide	E8251-90355
SCPI Command Reference	E8251-90356
Service Guide	E8251-90359
Specifications/Data Sheet (E8267D)	5989-0697EN
Specifications/Data Sheet (E8257D)	5989-0698EN
Specifications/Data Sheet (E8663D)	5989-4866EN

NOTE The E8257D/67D & E8663D PSG documentation can also be found on the web at <http://www.keysight.com/find/psg>.

Electrostatic Discharge (ESD) Protective Supplies

Table 2-25 Electrostatic Discharge (ESD) Protective Supplies

Description	Part Number
ESD connector end cap front-panel RF output	1401-0247
ESD connector end cap rear panel SMI	1252-4690
ESD connector end cap-GPIB	1252-5007
ESD connector end cap coherent carrier cut	1252-4696
2 X 4 Ft. Antistatic Table Mat with 15 FT. Ground Wire	9300-0797
5 Ft. Grounding Cord (for wrist strap)	9300-0980
Adjustable Antistatic Wrist Strap	9300-1367

Abbreviations Used in Part Descriptions

This section defines the reference designators, abbreviations, and option numbers that are used in the part descriptions throughout this chapter.

Table 2-26

Reference Designator	Definition
A	assembly
AT	attenuator
B	fan
DS	lamp
J	electrical connector; jack
W	cable; transmission path; wire

Table 2-27

Abbreviation	Definition
BN	buttonhead (screws)
CPU	central processing unit
CW	conical washer (screws)
EXT	external
FL	flathead (screws)
Ft	feet
Hex	hexagonal
GPIB	general purpose interface bus
HX	hexagonal recess (screws)
I	in-phase
LF	low frequency
M	meters or metric hardware
PC	patch lock (screws) or printed circuit
PN	panhead (screws)
Q	quadrature
Qty	quantity
RF	radio frequency

Replaceable Parts
Abbreviations Used in Part Descriptions

Table 2-27

Abbreviation	Definition
RPP	reverse power protection
SMA	subminiature type-A
TX	TORX recess (screws)

3 Assembly Replacement

Before You Replace an Assembly

CAUTION

Many of the assemblies in this instrument are very susceptible to damage from electrostatic discharge (ESD). Perform service procedures only at a static-safe workstation and wear a grounding strap.

Be sure to review the warning and caution statements described in **Chapter 5, “Safety and Regulatory”, on page 1**, prior to replacing an assembly in your signal generator.

After Replacing or Repairing an Assembly

After you have replaced or repaired an assembly, performance tests and adjustments may need to be performed. Please refer to **Chapter 3, “Assembly Replacement,”** for the list of performance tests and adjustments required for each assembly.

Assemblies That You Can Replace

- “Outer Instrument Cover” on page 6
- “Inner Instrument Cover” on page 8
- “Front Panel” on page 10
- “A1 Keyboard” on page 14
- “A2 Display” on page 17
- “A2DS1 Display Backlight (serial number prefix < US/MY5XXX3XXX only)” on page 20
- “A3 Power Switch” on page 22
- “A4 Inverter (serial number prefix < US/MY5XXX3XXX only)” on page 25
- “A5 Sampler, A6 Frac–N, A7 Reference (Standard and Option UNR/UNX/UNY), A8 Output, A45 Frac-N and A46 Offset” on page 27
- “A9 YIG Driver” on page 29
- “A10 ALC” on page 31
- “A11 Pulse/Analog Modulation Generator” on page 33
- “A12 Pulse Modulator Board” on page 35
- “A13 I/Q MUX (E8267D Standard or with Option 015) (Serial Prefixes <US4722/MY4722)” on page 37
- “A13 I/Q MUX (E8267D Standard or with Option H16/016) (Serial Prefixes >=US4722/MY4722)” on page 39
- “A14 Baseband Generator (E8267D Only)” on page 41
- “A17 Baseband Generator Interface (E8267D Only)” on page 43
- “A18 CPU” on page 45
- “A18BT1” on page 47
- “A19 Power Supply” on page 49
- “A20 SMI (Source Module Interface)” on page 52
- “A21 Rear–Panel Interface” on page 54
- “A22 Line Module” on page 56
- “A23 Lowband Coupler/Detector” on page 58
- “A24 20 GHz Highband Coupler (Options 503, 509, 520, and 521)” on page 60
- “A24 50 GHz Highband Coupler (Options 532 and 544)” on page 67
- “A24 67 GHz Highband Coupler (Options 550 and 567)” on page 69

- “A25 20 GHz Highband Detector (Options 503, 509, 520, & 521)” on page 71
- “A25 50 GHz Highband Detector (Options 532 and 544)” on page 76
- “A25 67 GHz Highband Detector (Options 550 and 567)” on page 78
- “A24 40 GHz Highband Coupler (Option 540)” on page 65
- “A24 50 GHz Highband Coupler (Options 532 and 544)” on page 67
- “A24 67 GHz Highband Coupler (Options 550 and 567)” on page 69
- “A25 20 GHz Highband Detector (Options 503, 509, 520, & 521)” on page 71
- “A25 40 GHz Highband Detector (Option 540)” on page 74
- “A25 50 GHz Highband Detector (Options 532 and 544)” on page 76
- “A25 67 GHz Highband Detector (Options 550 and 567)” on page 78
- “A25B Highband Detector Bias Board” on page 80
- “A26 MID (Microcircuit Interface Deck)” on page 82
- “A27 40 GHz Doubler (Option 540)” on page 85
- “A27 40 GHz Doubler (Options 532 and 544 only)” on page 87
- “A28 YIG Oscillator” on page 89
- “A29 20 GHz Doubler” on page 91
- “A30 Modulation Filter (Standard and Option 1EA/1EU)” on page 93
- “A31 Motherboard (E8257D & E8663D)” on page 96
- “A31 Motherboard (E8267D)” on page 99
- “A32 10 MHz Crystal Oscillator” on page 102
- “A33 6dB PAD (Options 503, 509, 520, and 521)” on page 104
- “A33 10dB PAD (Options 532 and 544)” on page 106
- “Rear Panel (Standard)” on page 108
- “Rear Panel (Option 1EM)” on page 111
- “A34 Internal Hard Drive (E8267D Only - Discontinued)” on page 115
- “A35 3–20 GHz I/Q Modulator (E8267D Only - Standard or with Option 015)” on page 117
- “A35 3–20 GHz I/Q Modulator (E8267D Only - Standard or with Option H16/016) (Serial Prefixes >=US4722/MY4722)” on page 119
- “A36 Quadraplier (Options 550 and 567)” on page 121
- “A37 Upconverter (E8267D Only)” on page 123

Assembly Replacement
Assemblies That You Can Replace

- “A38 Lowband Switch Filter” on page 125
- “A39 Directional Sweep Coupler” on page 127
- “A40 Compact Flash Drive Assembly” on page 129
- “A41 Flash Drive Door Assembly” on page 131
- “A42 20 GHz Power Amp (Option 521)” on page 133
- “A43 Lowband Amp Filter” on page 135
- “A44 Scan Modulation Bias Adapter (E8257D-520 and E8663D Only)” on page 137
- “AT1 90 dB Attenuator” on page 139
- “AT1 115 dB Attenuator” on page 141
- “AT1 90 dB Attenuator (Option 1EM)” on page 143
- “AT1 115 dB Attenuator (Option 1EM)” on page 145
- “B1 Fan” on page 147

This page intentionally left blank.

Outer Instrument Cover

Tools Required

- T-15 driver
- T-20 driver

Removal Procedure

Refer to **Figure 3-1** for this procedure.

- 1. Disconnect the power cord.**
- 2. Using the T-20 driver, loosen and remove the two screws (1) and remove the strap handle (2).**
- 3. Using the T-15 driver, remove the center screws (3) from the four rear panel feet (4).**
- 4. Remove the four bottom feet (5) from the cover by lifting the tab and sliding the foot toward the tab.**
- 5. Place the signal generator on its side.**
- 6. Tilt the signal generator forward and slide the outer cover (6) back to remove it from the frame.**

Replacement Procedure

- Reverse the order of the removal procedures.
- Torque all T-15 screws to 21 in-lbs.
- Torque all T-20 screws to 21 in-lbs.

Assembly Replacement
Outer Instrument Cover

Figure 3-1 Outer Instrument Cover Removal

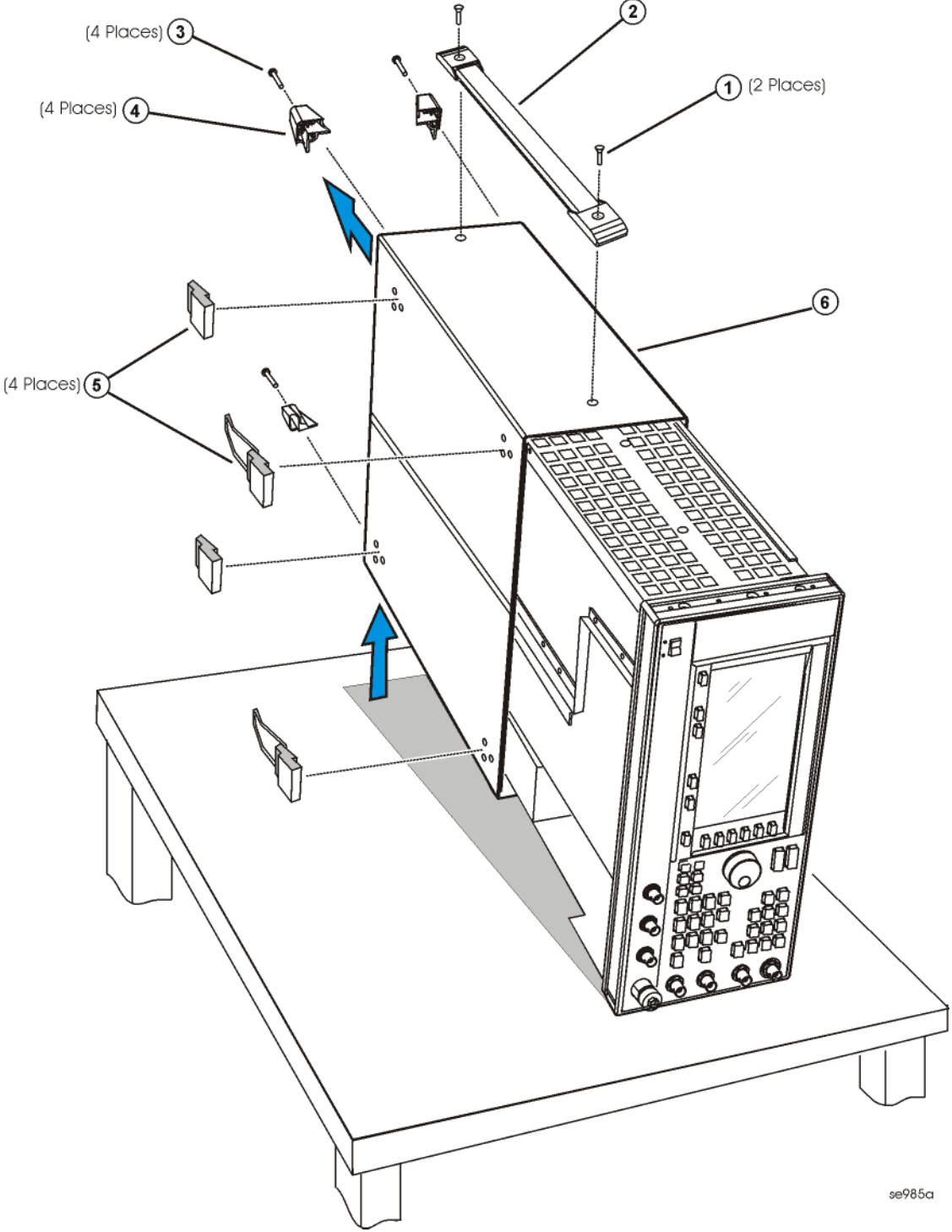

se985a

Inner Instrument Cover

Tools Required

- T-10 driver

Removal Procedure

Refer to **Figure 3-2** for this procedure.

- 1. Disconnect the power cord.**
- 2. Remove the outer cover from the signal generator. Refer to “Outer Instrument Cover” on page 6.**
- 3. Place the signal generator flat and upright with the front panel facing you.**
- 4. Using the T-10 driver, remove all twenty-two screws (1) from the inner cover (2).**
- 5. Remove the inner cover.**

Replacement Procedure

- Reverse the order of the removal procedures.
- Torque all T-10 screws to 9 in-lbs.

Figure 3-2 Inner Instrument Cover Removal

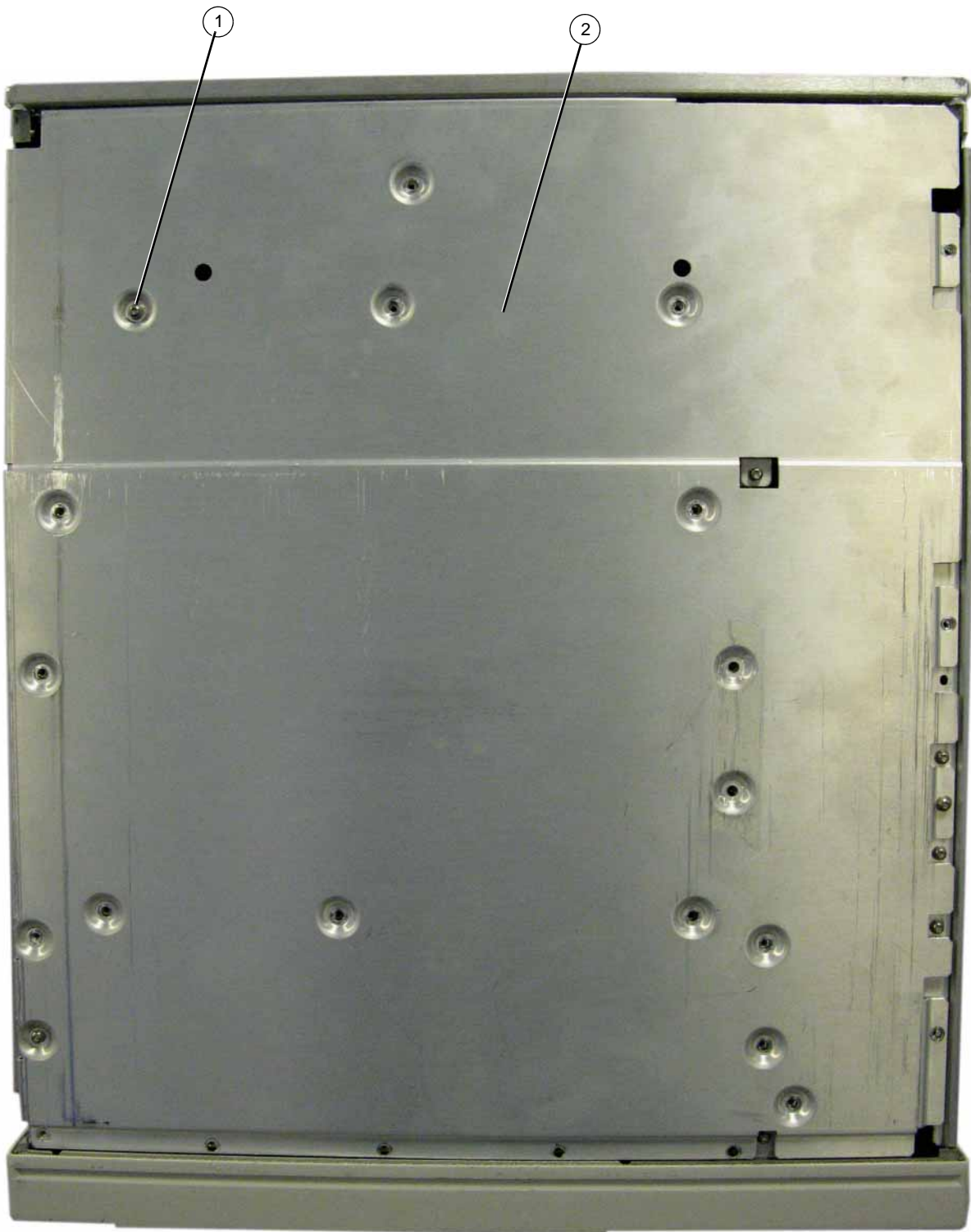

Front Panel

Tools Required

- T–10 driver
- T–15 driver
- needle–nose pliers

Removal Procedure

NOTE To remove the Front Panel on signal generators with Option 1EM, complete steps 1 through 6 and steps 20 through 23.

Refer to **Figure 3-3** for instruments with serial number prefix < US/MY5XXX3XXX for this procedure.

Refer to **Figure 3-4** for instruments with serial number prefix > US/MY5XXX3XXX for this procedure.

1. Disconnect the power cord.
2. Remove the covers from the signal generator. Refer to “**Outer Instrument Cover**” on page 6 and “**Inner Instrument Cover**” on page 8.
3. Using the T–10 driver, remove the four screws from the Baseband Generator cover.
4. Remove the side trims that cover the six screws.
5. Using the T–15 driver, remove the six screws (1) from the sides of the frame.
6. Using the T–10 driver, remove one screw on the top (2) and bottom (3) frame.

CAUTION Before removing the front panel from the signal generator, lift and support the front of the signal generator’s frame.

7. Slide the front panel over the RF output connector (non–1EM signal generators only).
8. Using the needle–nose pliers, disconnect the following flexible cables:
 - W1 (EXT 1 INPUT) from the A11 Pulse/Analog Modulation Generator J401 (non–1EM signal generators only).
 - W2 (EXT 2 INPUT) from the A11 Pulse/Analog Modulation Generator J402 (non–1EM signal generators only).

- W3 (LF OUTPUT) from the A11 Pulse/Analog Modulation Generator J403 (non-1EM signal generators only).
 - W4 (ALC INPUT) from the A10 ALC J4 (non-1EM signal generators only).
 - W5 (PULSE/TRIGGER GATE INPUT) from the A11 Pulse/Analog Modulation Generator J201 (non-1EM signal generators only).
 - W6 (PULSE VIDEO OUTPUT) from the A11 Pulse/Analog Modulation Generator J203 (non-1EM signal generators only).
 - W7 (PULSE SYNC OUTPUT) from the A11J202 (non-1EM signal generators only).
 - W49 (I IN) from the A35J7 (E8267D only).
 - W50 (Q IN) from the A35J8 (E8267D non-1EM signal generators only).
 - W51 (DATA) from the A31J500 (E8267D non-1EM signal generators only).
 - W52 (DATA CLOCK) from the A31J501 (E8267D non-1EM signal generators only).
 - W53 (SYMBOL SYNC) from the A31J502 (E8267D non-1EM signal generators only).
- 9.** Disconnect the A1W1 display cable from the A31 Motherboard P13.
- 10.** For serial number prefix < US/MY5XXX3XXX, disconnect the A4W1 inverter cable from the A31 Motherboard P12 (refer to [Figure 3-3](#)).
- And for serial number prefix > US/MY5XXX3XXX, disconnect the A2W1 display cable from the A31 Motherboard P12. (refer to [Figure 3-4](#)).
- 11.** Disconnect the W9 ribbon cable from the A31 Motherboard P11.
- 12.** Remove the front panel.

Replacement Procedure

1. Reverse the order of the removal procedure.
2. Torque all T-10 screws to 9 in-lbs.
3. Torque all T-15 screws to 21 in-lbs.
4. Perform the post-repair adjustments and performance tests that pertain to this removal procedure.

Figure 3-3 Front Panel Removal with serial prefixes < US/MY5XXX3XXX¹

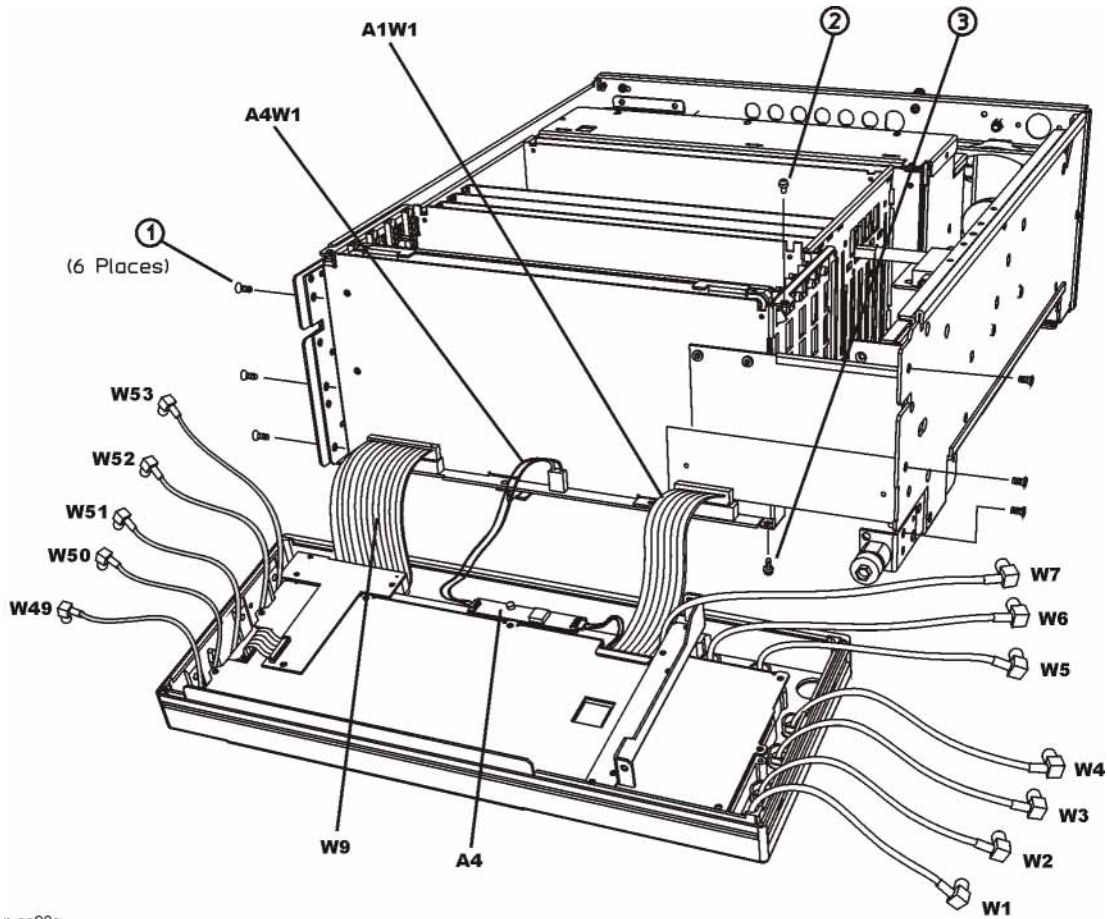

p-se98a

1. Applicable if the A2 does not have the most current LCD.

Assembly Replacement
Front Panel

Figure 3-4

Front Panel Removal with serial prefixes > US/MY5XXX3XXX

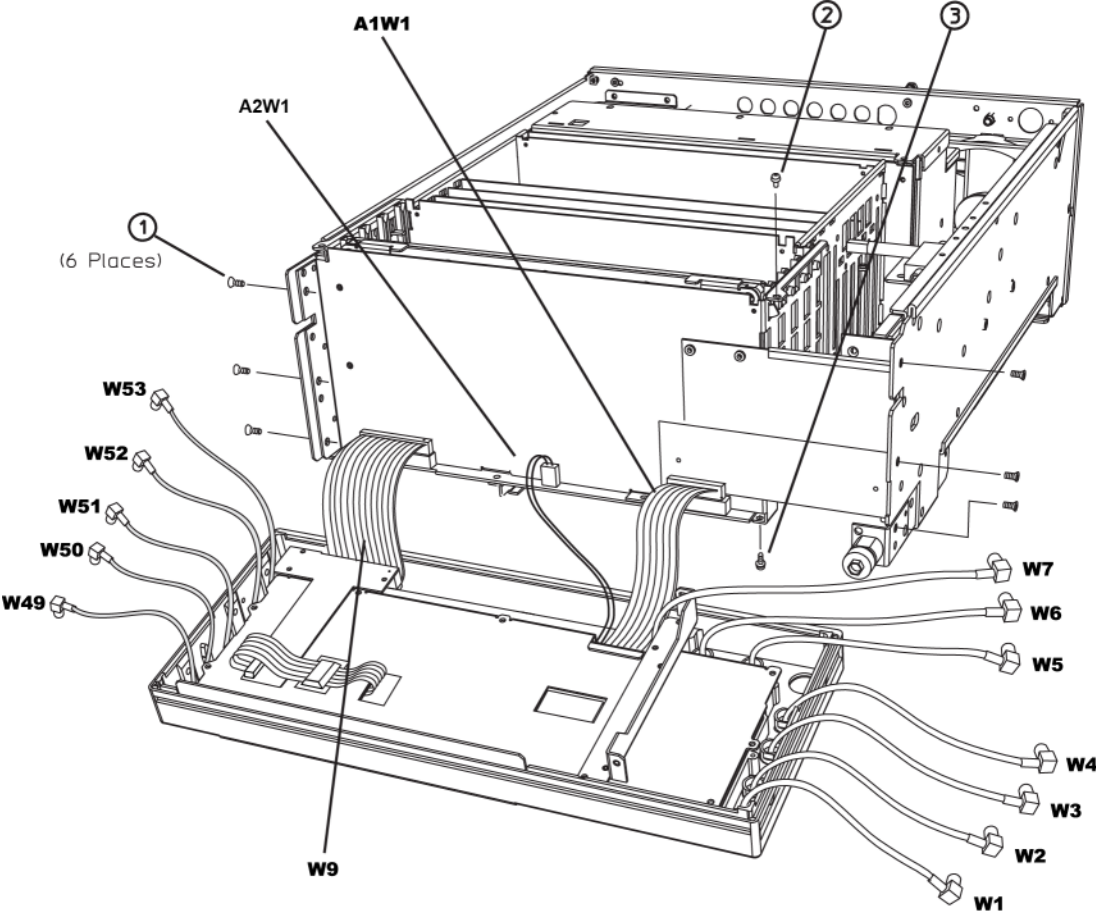

p-se98a_noinv

A1 Keyboard

Tools Required

- T-10 driver

Removal Procedure

Refer to **Figure 3-5** for instruments with serial number prefix < US/MY5XXX3XXX for this procedure.

Refer to **Figure 3-6** for instruments with serial number prefix > US/MY5XXX3XXX for this procedure.

1. Disconnect the power cord.
2. Remove the front panel. Refer to **“Front Panel” on page 10**.
3. For serial number prefix < US/MY5XXX3XXX, disconnect the A2DS1W1 cable from the A4 Inverter.

For serial number prefix > US/MY5XXX3XXX, disconnect the A2W1 cable from the A2 Display.
4. Disconnect the W8 ribbon cable from the A3 Power Switch by lifting the white tabs on the connector.
5. Using the T-10 driver, remove the four screws (12) from the A3 Power Switch.
6. Remove the A3 Power Switch.
7. Using the T-10 driver, remove the ten screws (11) that secure the RFI shielding (10) to the front panel.
8. Remove the metal shielding.
9. Using the T-10 driver, remove the four screws (9) that secure the A2 Display to the front panel.
10. Remove the A2 Display.
11. Using the T-10 driver, remove the nine screws (8) that secure the A1 Keyboard to the front panel.
12. Remove the A1 Keyboard.

Replacement Procedure

1. Reverse the order of the removal procedures.
2. Torque all T-10 screws to 9 in-lbs.
3. Perform the post-repair adjustments and performance tests that pertain to this removal procedure.

Figure 3-5

A1 Keyboard Removal with serial prefixes < US/MY5XXX3XXX¹

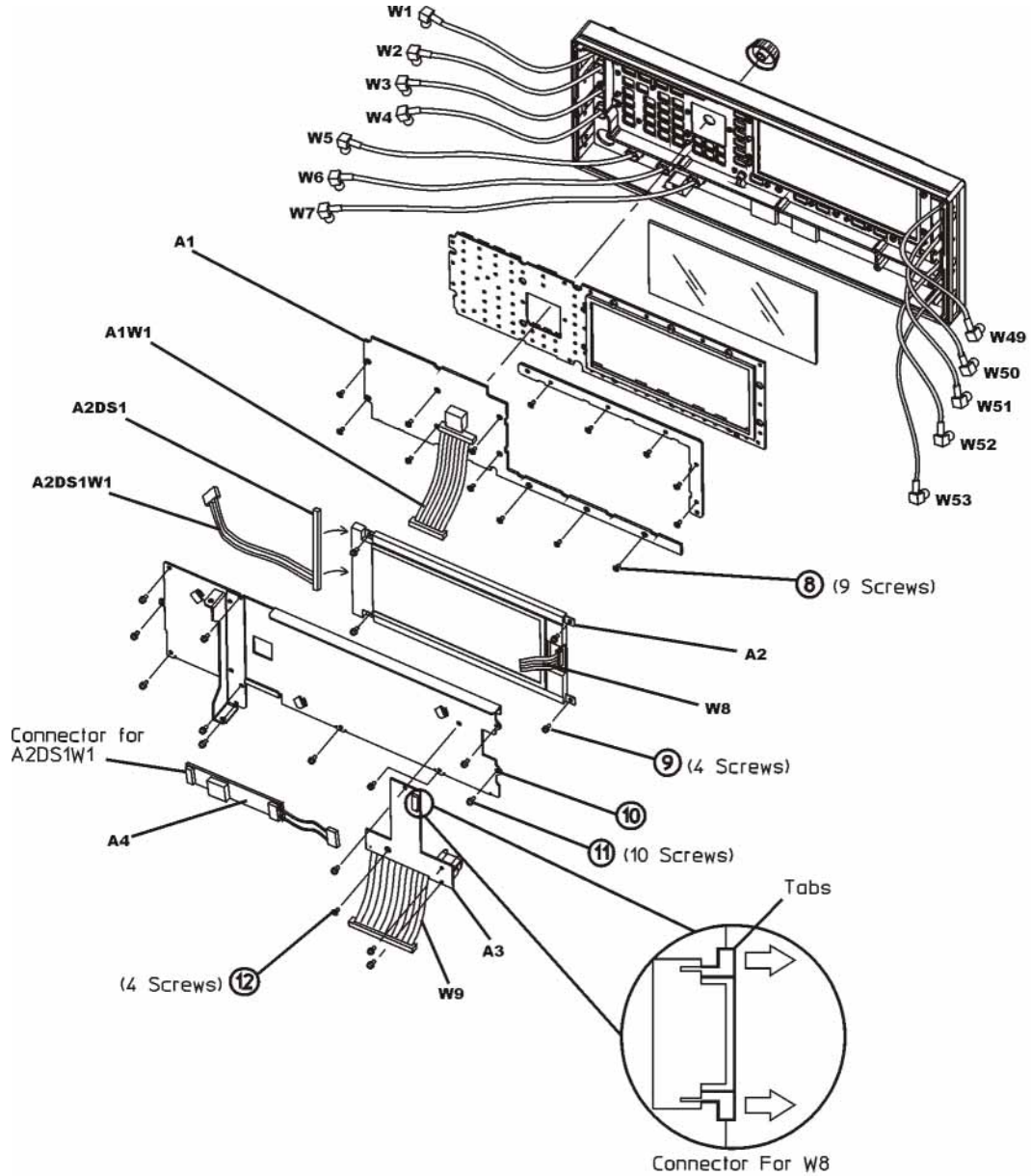

p-se97a

1. Applicable if the A2 does not have the most current LCD.

Assembly Replacement
A1 Keyboard

Figure 3-6

A1 Keyboard Removal with serial prefixes > US/MY5XXX3XXX

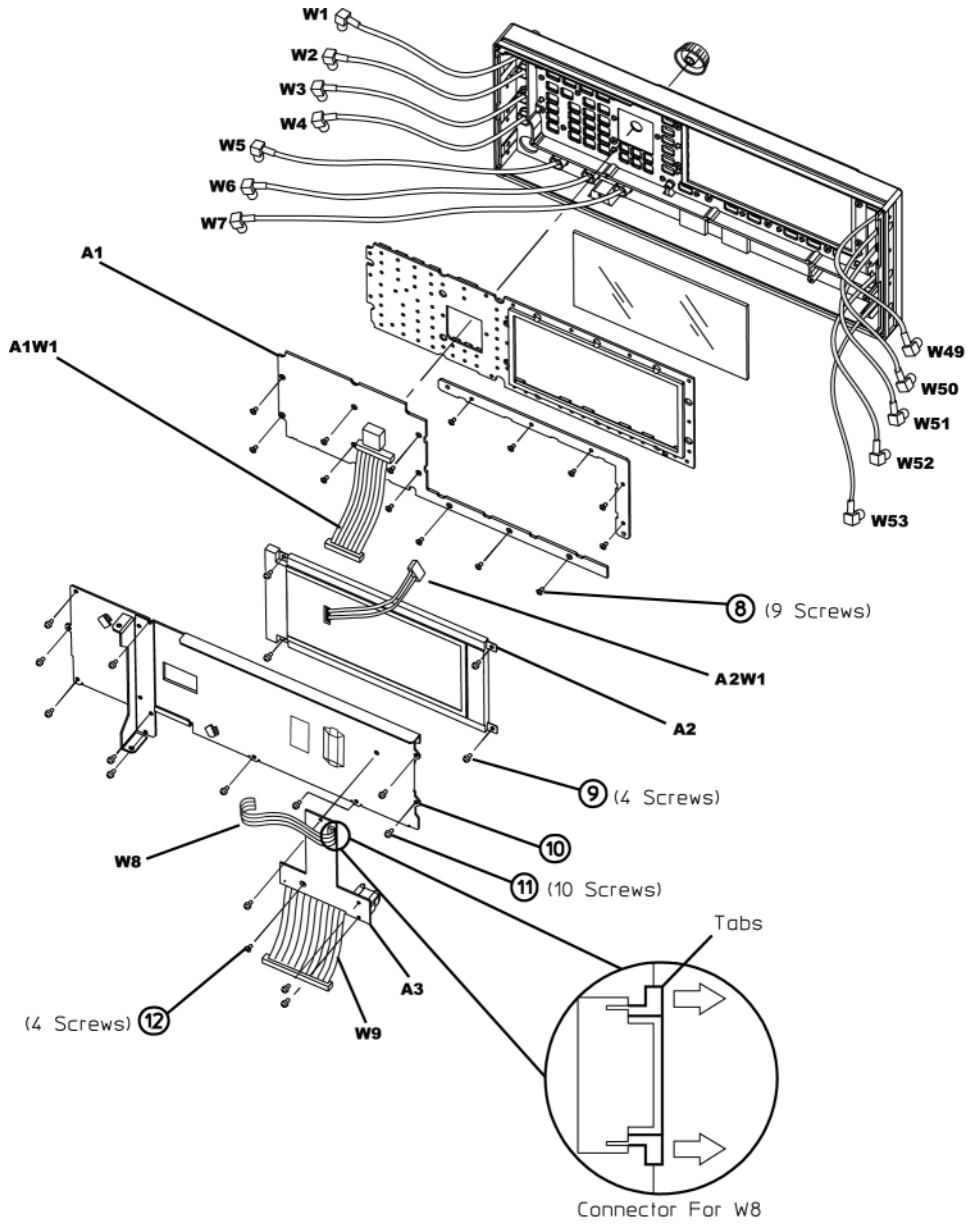

p-se97a2_noinv

A2 Display

Tools Required

- T-10 driver

Removal Procedure

Refer to **Figure 3-7** for instruments with serial number prefix < US/MY5XXX3XXX for this procedure.

Refer to **Figure 3-8** for instruments with serial number prefix > US/MY5XXX3XXX for this procedure.

1. Disconnect the power cord.
2. Remove the front panel. Refer to **“Front Panel” on page 10**.
3. For serial number prefix < US/MY5XXX3XXX, disconnect the A2DS1W1 cable from the A4 Inverter and discard/recycle the A4 Inverter (i.e., The replacement A2 Display does not need the old A4 Inverter).

For serial number prefix > US/MY5XXX3XXX, disconnect the A2W1 cable from the A2 Display.
4. Disconnect the W8 ribbon cable from the A3 Power Switch by lifting the white tabs on the connector.
5. Using the T-10 driver, remove the four screws (12) from the A3 Power Switch.
6. Remove the A3 Power Switch.
7. Using the T-10 driver, remove the ten screws (11) that secure the RFI shielding (10) to the front panel.
8. Remove the metal shielding.
9. Using the T-10 driver, remove the four screws (9) that secure the A2 Display to the front panel.
10. Remove the A2 Display.

Replacement Procedure

1. For instruments with serial number prefix < US/MY5XXX3XXX, reverse the order of the removal procedure, except now the A2W1 cable is connected straight to the A31 Motherboard P12 since the A4 is now integrated into the A2 Display.

For instruments with serial number prefix > US/MY5XXX3XXX, reverse the order of the removal procedure.

2. Torque all T-10 screws to 9 in-lbs.

3. Perform the post-repair adjustments and performance tests that pertain to this removal procedure.

Figure 3-7 A2 Display Removal with serial prefixes < US/MY5XXX3XXX¹

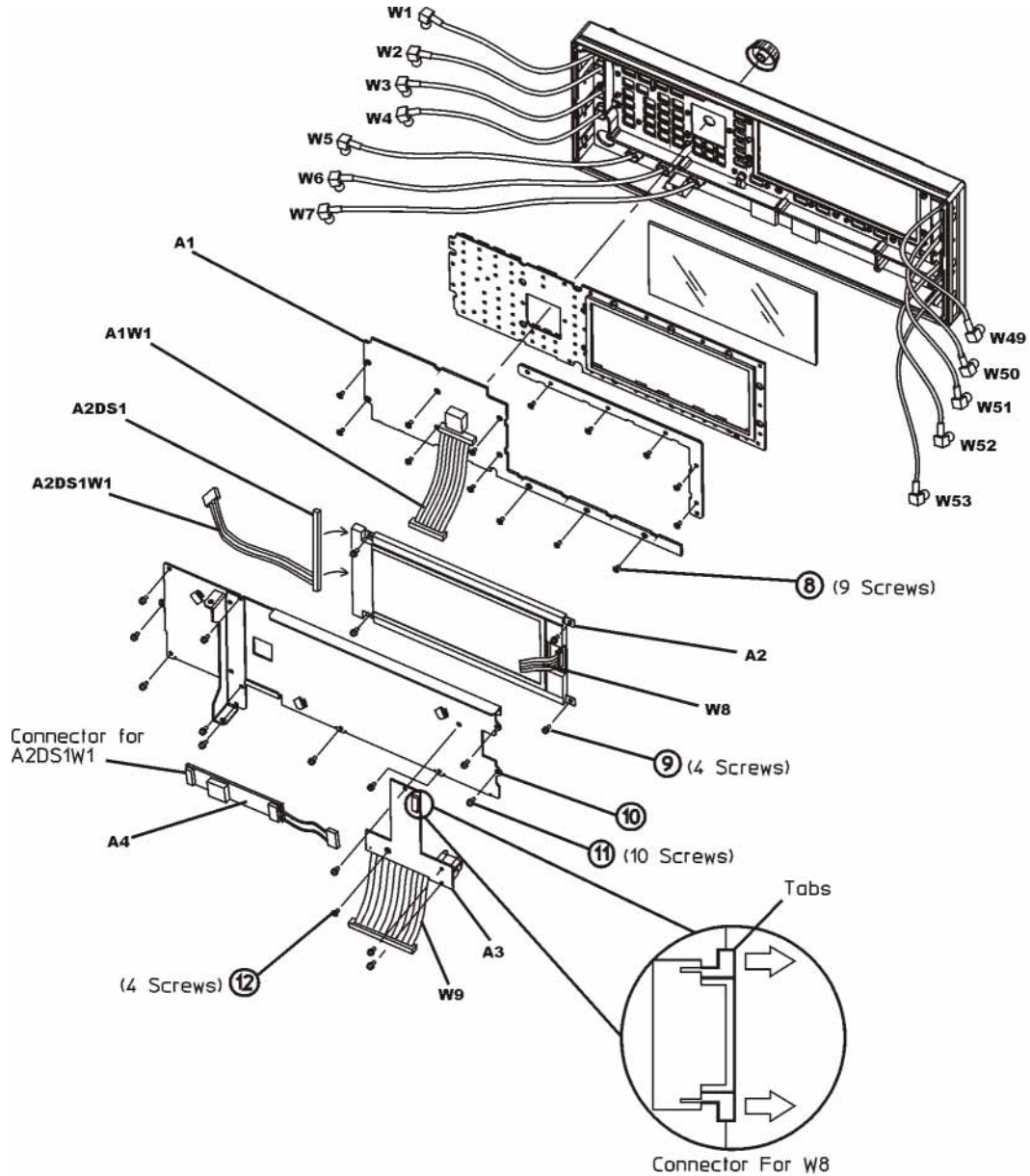

p-se97a

1. Applicable if the A2 does not have the most current LCD.

Assembly Replacement
A2 Display

Figure 3-8

A2 Display Removal with serial prefixes > US/MY5XXX3XXX

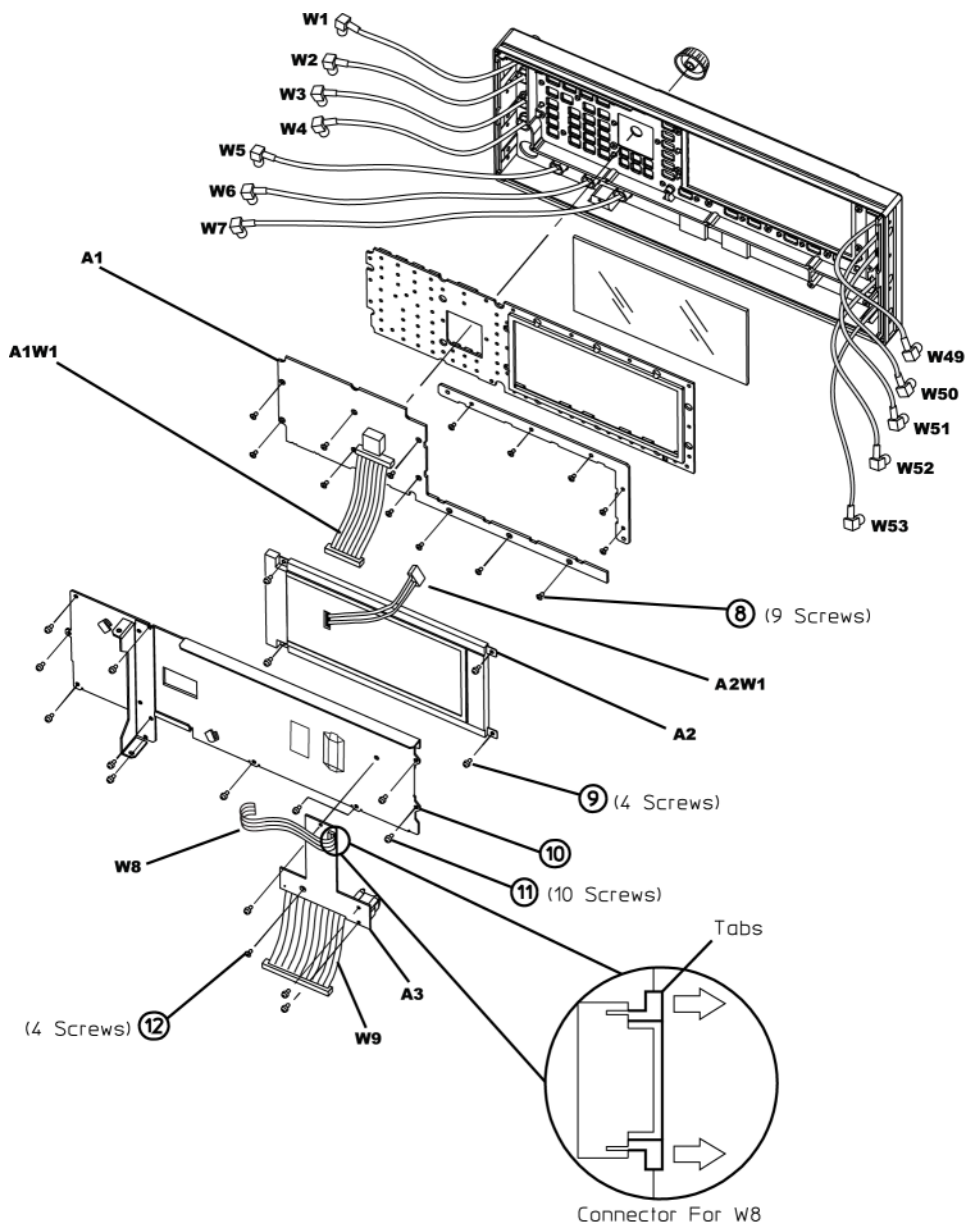

p-se97a2_noinv

A2DS1 Display Backlight (serial number prefix < US/MY5XXX3XXX only)

Tools Required

- T-10 driver
- small phillips screw driver

Removal Procedure

Refer to **Figure 3-9**.

1. Disconnect the power cord.
2. Remove the front panel. Refer to **“Front Panel” on page 10**.
3. Disconnect the A2DS1W1 cable from the A4 Inverter.
4. Disconnect the W8 ribbon cable from the A3 Power Switch by lifting the white tabs on the connector.
5. Using the T-10 driver, remove the four screws (12) from the A3 Power Switch.
6. Remove the A3 Power Switch.
7. Using the T-10 driver, remove the ten screws (11) that secure the RFI shielding (10) to the front panel.
8. Remove the metal shielding.
9. Using the T-10 driver, remove the four screws (9) that secure the A2 Display to the front panel.
10. Remove the A2 Display.
11. Using a small phillips screw driver, remove the screw (1) that secures the cover (2) over the A2DS1 Display Backlight.
12. Remove the A2DS1 Display Backlight.

Replacement Procedure

NOTE

When replacing the A2DS1 Display Backlight make sure the reflective paper is behind the light.

1. Reverse the order of the removal procedure.
2. Torque all T-10 screws to 9 in-lbs.

A3 Power Switch

Tools Required

- T-10 driver

Removal Procedure

Refer to **Figure 3-10** for instruments with serial number prefix < US/MY5XXX3XXX.

Refer to **Figure 3-11** for instruments with serial number prefix > US/MY5XXX3XXX.

1. Disconnect the power cord.
2. Remove the front panel. Refer to **“Front Panel” on page 10**.
3. Disconnect the W8 ribbon cable from the A3 Power Switch by lifting the white tabs on the connector.
4. Using the T-10 driver, remove the four screws (12) from the A3 Power Switch.
5. Remove the A3 Power Switch.

Replacement Procedure

1. Reverse the order of the removal procedure.
2. Torque all T-10 screws to 9 in-lbs.
3. Perform the post-repair adjustments and performance tests that pertain to this removal procedure.

Figure 3-10

A3 Power Switch Removal with serial number prefix < US/MY5XXX3XXX¹

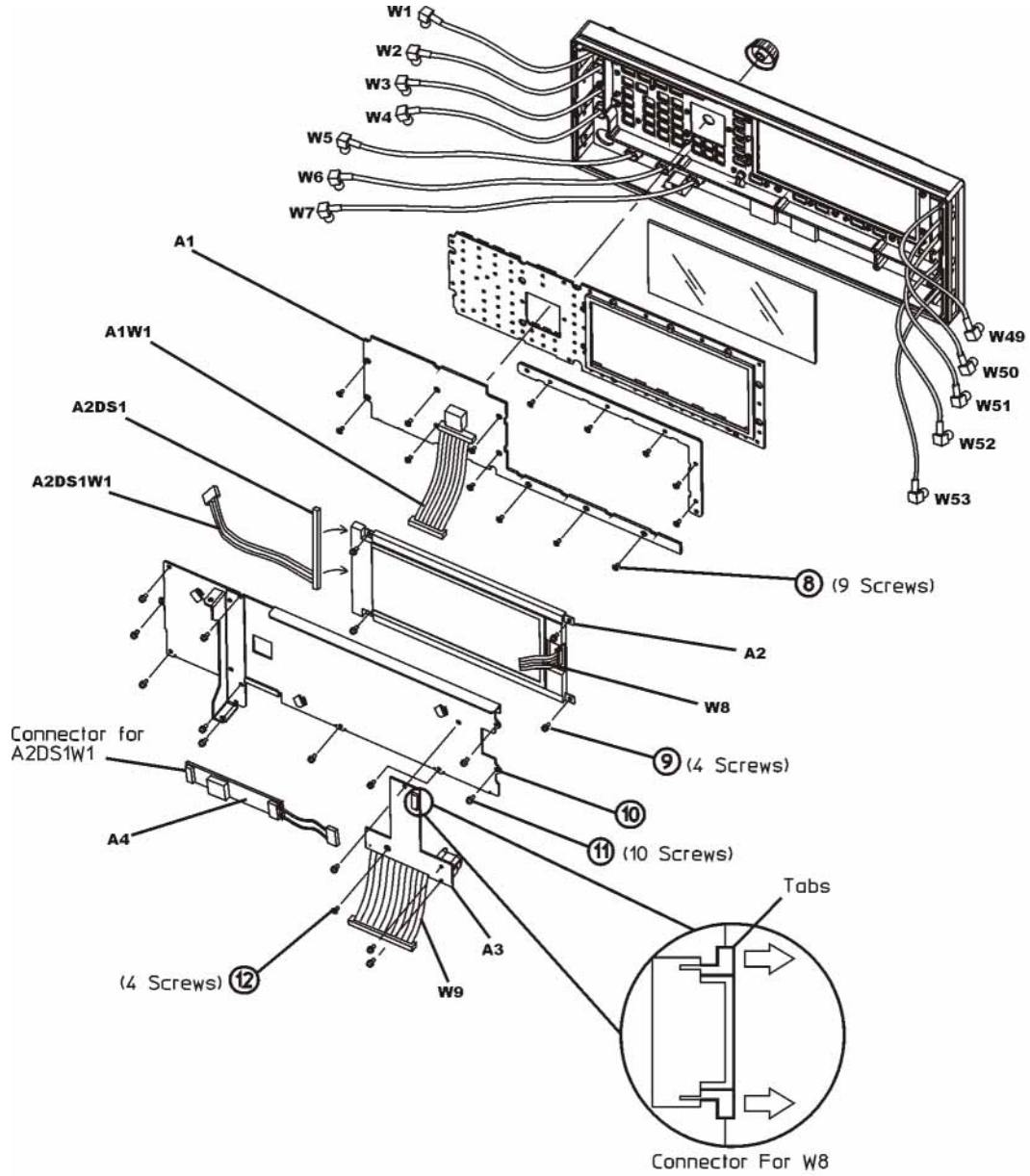

p-se97a

1. Applicable if the A2 does not have the most current LCD.

Assembly Replacement
A3 Power Switch

Figure 3-11

A3 Power Switch Removal with serial number prefix > US/MY5XXX3XXX

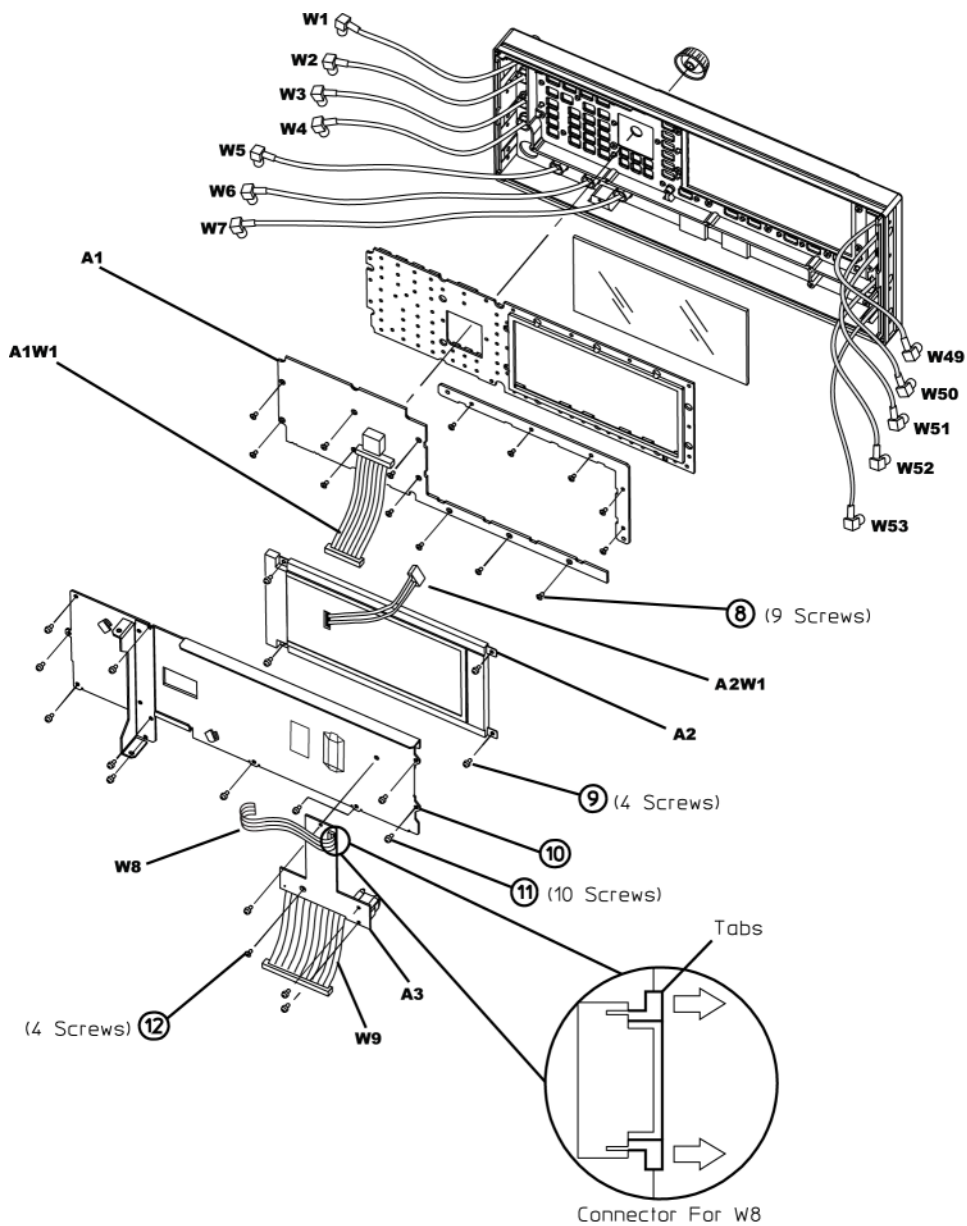

p-se97a2_noinv

A4 Inverter (serial number prefix < US/MY5XXX3XXX only)

Tools Required

- none

Removal Procedure

Refer to **Figure 3-12** for this procedure.

1. Disconnect the power cord.
2. Remove the front panel. Refer to **“Front Panel” on page 10**.
3. Disconnect the A4W1 cable from the A31 Motherboard P12.
4. Disconnect the A2DSW1 cable from the A4 Inverter.

CAUTION

The A4 Inverter is fragile and can be damaged when pulled away from the velcro attachment.

5. Remove the A4 Inverter by carefully pulling it away from the front panel.

Replacement Procedure

1. Reverse the order of the removal procedure.
2. Perform the post-repair adjustments and performance tests that pertain to this removal procedure.

Assembly Replacement
A4 Inverter (serial number prefix < US/MY5XXX3XXX only)

Figure 3-12 A4 Inverter Removal

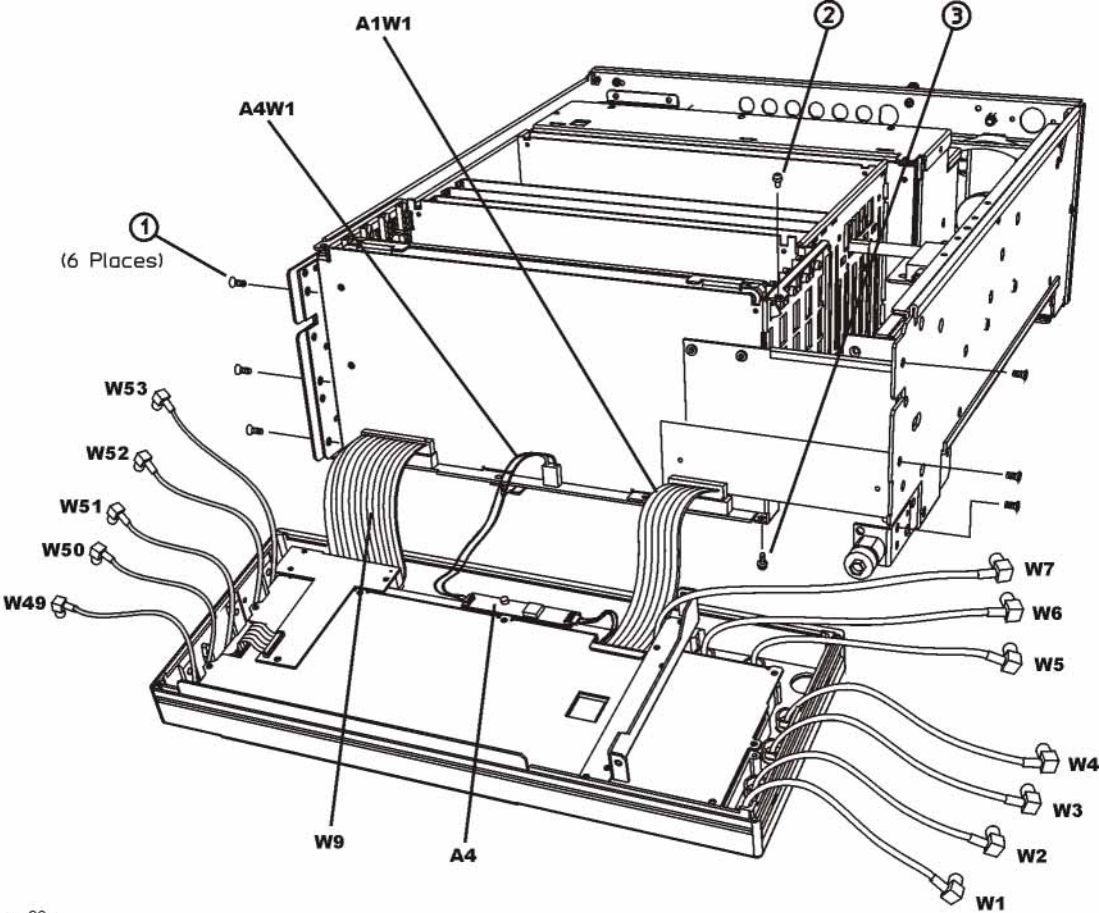

p-se98a

A5 Sampler, A6 Frac-N, A7 Reference (Standard and Option UNR/UNX/UNY), A8 Output, A45 Frac-N and A46 Offset

Tools Required

- none

Removal Procedure

Refer to **Figure 3-13** for this procedure.

1. Disconnect the power cord.
2. Remove the covers from the signal generator. Refer to “**Outer Instrument Cover**” on page 6 and “**Inner Instrument Cover**” on page 8.
3. Position the signal generator with the front panel facing you.
4. Lift the retention levers and disconnect the board assembly from the A31 Motherboard.
5. Lift the board assembly out of the slot.

Replacement Procedure

1. Reverse the order of the removal procedure.
2. Perform the post-repair adjustments and performance tests that pertain to this removal procedure.

Assembly Replacement
A5 Sampler, A6 Frac-N, A7 Reference (Standard and Option UNR/UNX/UNY), A8
Output, A45 Frac-N and A46 Offset

Figure 3-13 A5 Sampler, A6 Frac-N, A7 Reference, A8 Output, A45 Frac-N and A46 Offset

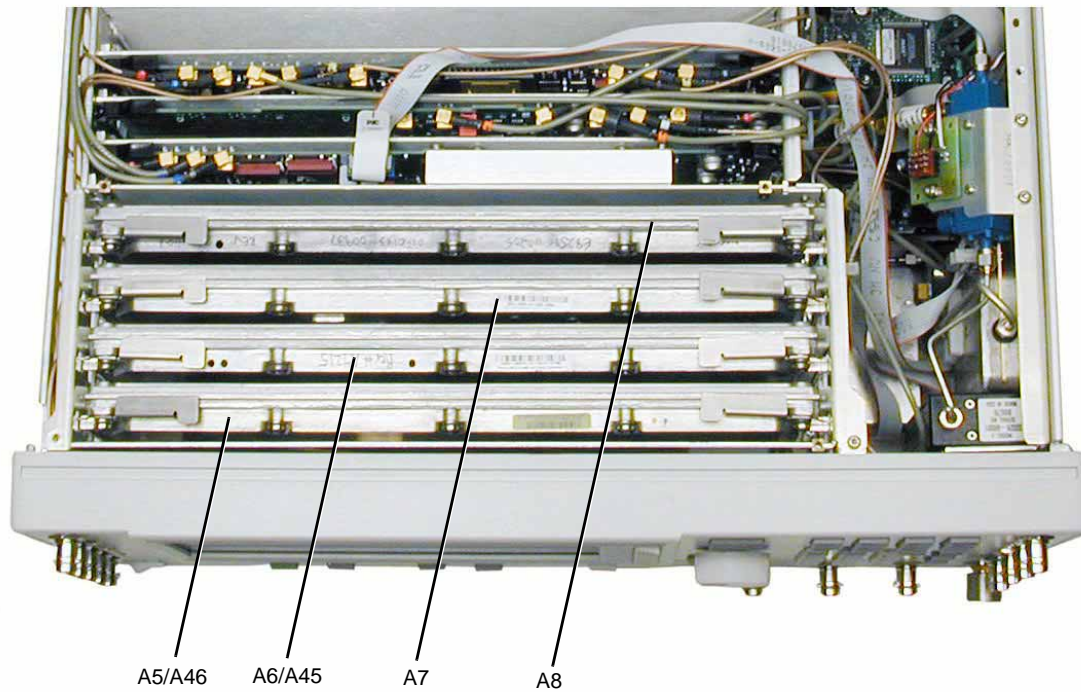

p2_a5

A9 YIG Driver

Tools Required

- needle-nose pliers

Removal Procedure

Refer to **Figure 3-14** for this procedure.

1. Disconnect the power cord.
2. Remove the covers from the signal generator. Refer to “**Outer Instrument Cover**” on page 6 and “**Inner Instrument Cover**” on page 8.
3. Position the signal generator with the front panel facing you.
4. Disconnect the W12 ribbon cable from A9J5.
5. Using the needle-nose pliers, disconnect the following flexible cables:
 - W54 from A9J9
 - W11 from A9J4
 - W10 from A9J3
6. Lift the retention levers and disconnect the A9 YIG Driver from the A31 Motherboard.
7. Lift the A9 YIG Driver out of the slot.

Replacement Procedure

1. Reverse the order of the removal procedure.
2. Perform the post-repair adjustments and performance tests that pertain to this removal procedure.

Assembly Replacement
A9 YIG Driver

Figure 3-14 A9 YIG Driver

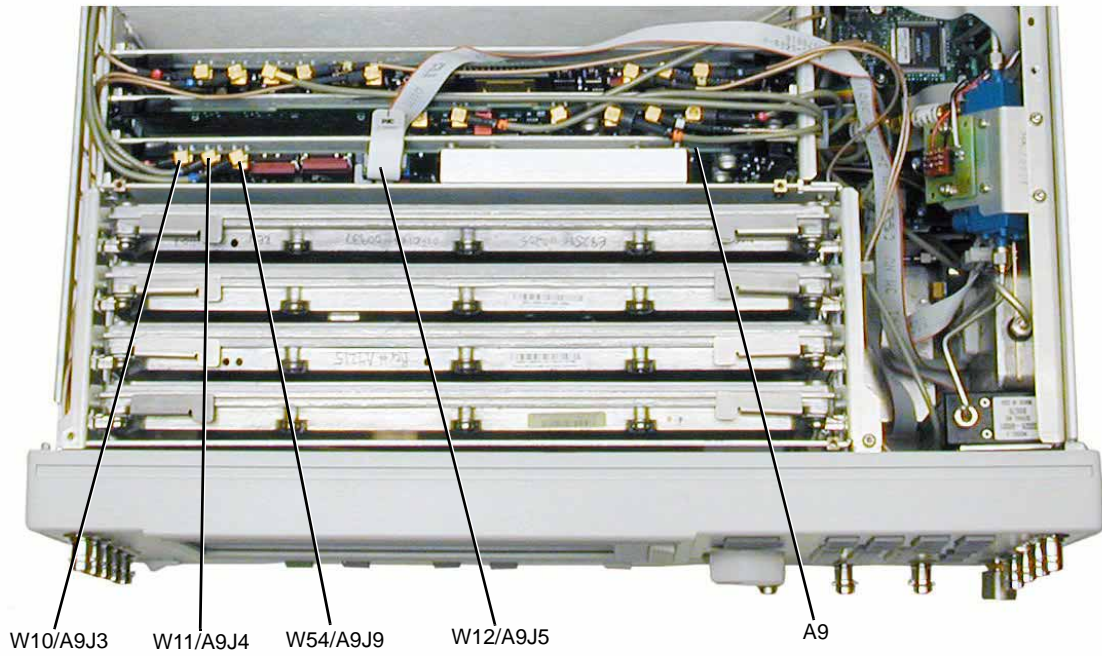

p2_a5

A10 ALC

Tools Required

- needle-nose pliers

Removal Procedure

Refer to **Figure 3-15** for this procedure.

1. Disconnect the power cord.
2. Remove the covers from the signal generator. Refer to “**Outer Instrument Cover**” on page 6 and “**Inner Instrument Cover**” on page 8.
3. Position the signal generator with the front panel facing you.
4. Using the needle-nose pliers, disconnect the following flexible cables:
 - W15 from A10J3
 - W14 from A10J5
 - W4 from A10J4
 - W55 from A10J304
 - W13 from A10J201
 - W95 from A10J202
 - W111 from A10J203
 - Option 532/544 – W110 from A10J202 or
Option 550/567 – W95 from A10J202
 - Option 550/567 – W111 from A10J203
 - W122 from A10J303 (E8267D only with serial prefixes
>US4722/MY4722)
5. Lift the retention levers and disconnect the A10 ALC from the A31 Motherboard.
6. Lift the A10 ALC out of the slot.

Replacement Procedure

1. Reverse the order of the removal procedure.
2. Perform the post-repair adjustments and performance tests that pertain to this removal procedure.

Assembly Replacement
A10 ALC

Figure 3-15 A10 ALC

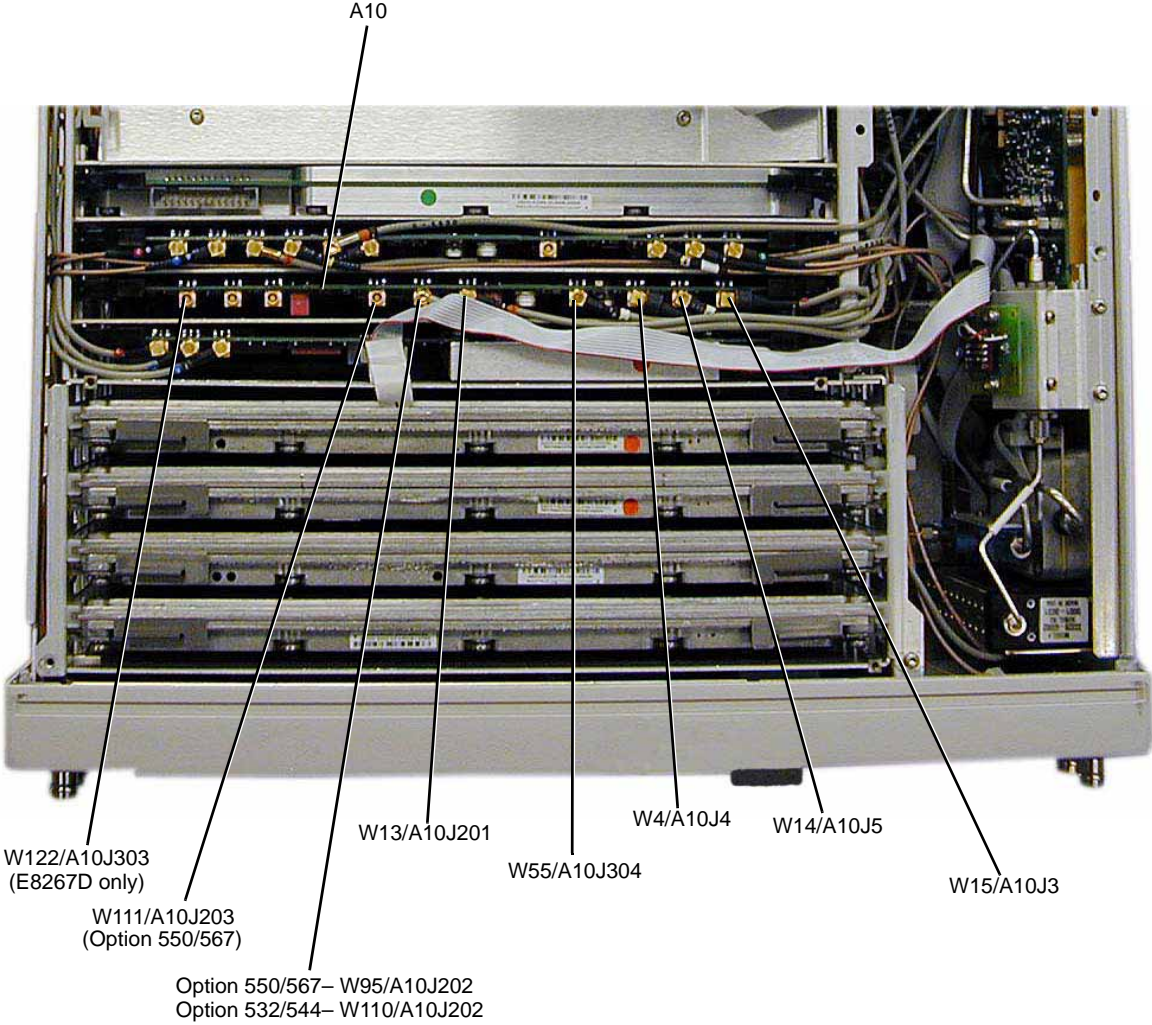

A11 Pulse/Analog Modulation Generator

Tools Required

- needle-nose pliers

Removal Procedure

Refer to **Figure 3-16** for this procedure.

1. Disconnect the power cord.
2. Remove the covers from the signal generator. Refer to “**Outer Instrument Cover**” on page 6 and “**Inner Instrument Cover**” on page 8.
3. Position the signal generator with the front panel facing you.
4. Using the needle-nose pliers, disconnect the following flexible cables:
 - W1 from A11J401
 - W2 from A11J402
 - W3 from A11J403
 - W5 from A11J201
 - W96 from A11J206
 - W17 from A11J205
 - W16 from A11J204
 - W7 from A11J202
 - W6 from A11J203
5. Lift the retention levers and disconnect the A11 Pulse/Analog Modulation Generator from the A31 Motherboard.
6. Lift the A11 Pulse/Analog Modulation Generator out of the slot.

Replacement Procedure

1. Reverse the order of the removal procedure.
2. Perform the post-repair adjustments and performance tests that pertain to this removal procedure.

Assembly Replacement
A11 Pulse/Analog Modulation Generator

Figure 3-16 A11 Pulse/Analog Modulation Generator

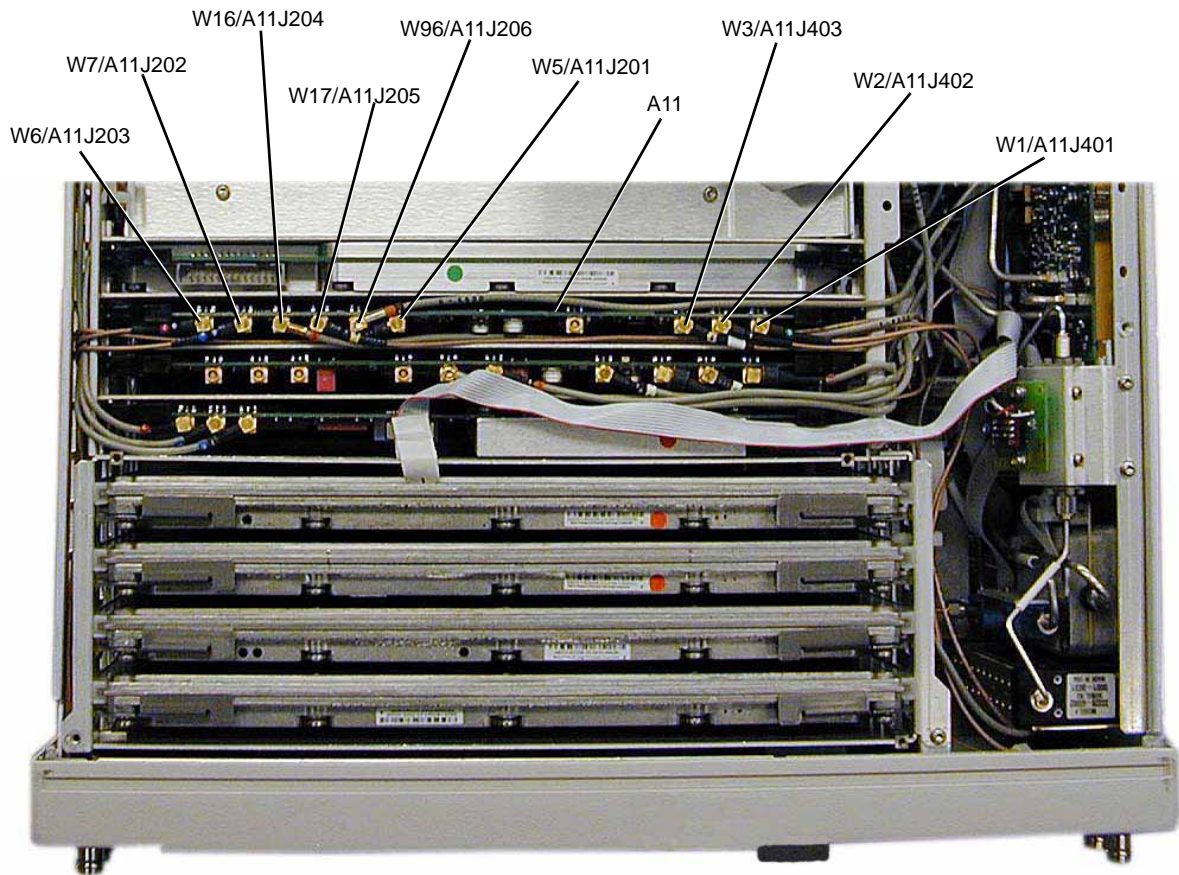

A12 Pulse Modulator Board

Tools Required

- T-10 driver
- 5/16" open-ended wrench

Removal Procedure

Refer to **Figure 3-17** for this procedure.

- 1. Disconnect the power cord.**
- 2. Remove the covers from the signal generator. Refer to “Outer Instrument Cover” on page 6 and “Inner Instrument Cover” on page 8.**
- 3. Position the signal generator so that the A31 Motherboard is facing you and the RF deck is on top.**
- 4. Using the 5/16" open-ended wrench, disconnect the W16, W75, and W76 RF cables from the A12 Pulse Modulator Board.**
- 5. Disconnect the W69 ribbon cable from the A12 Pulse Modulator Board.**
- 6. Using the T-10 driver, remove the two screws (1) that attach the A12 Pulse Modulator Board to the main chassis.**
- 7. Remove the A12 Pulse Modulator Board from the RF deck.**
- 8. Using the T-10 driver, remove the sheet metal from A12 Pulse Modulator Board.**

Replacement Procedure

- Reverse the order of the removal procedure.
- Perform the post-repair adjustments and performance tests that pertain to this removal procedure.

Assembly Replacement
A12 Pulse Modulator Board

Figure 3-17 A12 Pulse Modulator Board

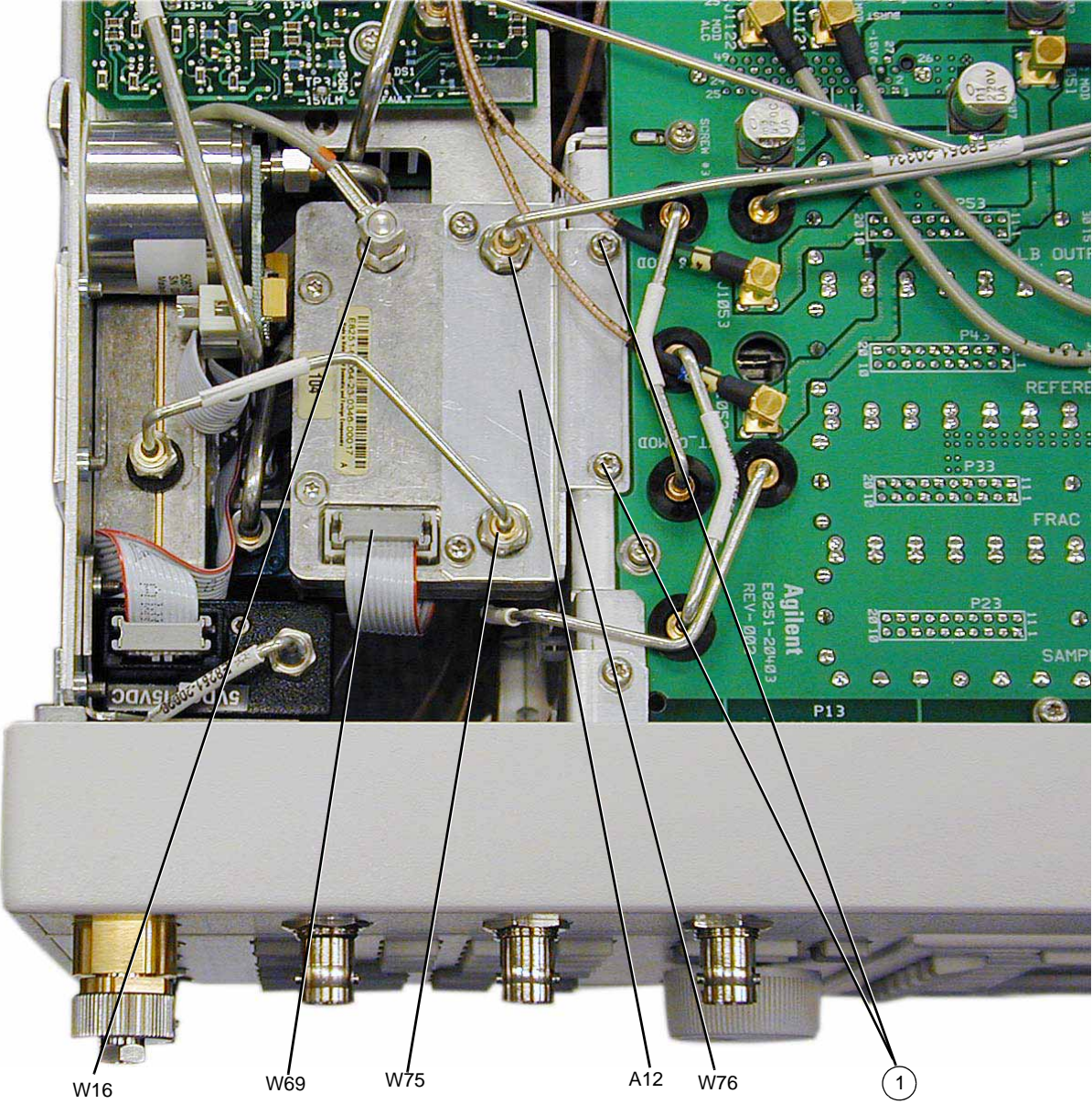

A13 I/Q MUX (E8267D Standard or with Option 015) (Serial Prefixes <US4722/MY4722)

Tools Required

- T-10 driver
- needle-nose pliers

Removal Procedure

Refer to **Figure 3-18** for this procedure.

1. Disconnect the power cord.
2. Remove the covers from the signal generator. Refer to “**Outer Instrument Cover**” on page 6 and “**Inner Instrument Cover**” on page 8.
3. Position the signal generator with the front panel facing you.
4. Using the T-10 driver, remove the four screws from the Baseband Generator cover.
5. Using the needle-nose pliers, disconnect the following flexible cables:
 - W63 from A13J5
 - W62 from A13J6
 - W49 from A13J7
 - W50 from A13J8
 - W61 from A13J9
 - W60 from A13J10
 - W59 from A13J11
 - W58 from A13J12
 - W57 from A13J13
 - W56 from A13J14
6. Lift the retention levers and disconnect the A13 I/Q MUX from the A31 Motherboard.
7. Lift the A13 I/Q MUX out of the slot.

Replacement Procedure

1. Reverse the order of the removal procedure. (See the internal cover overlay for cable color codes.)

Assembly Replacement
A13 I/Q MUX (E8267D Standard or with Option 015) (Serial Prefixes
<US4722/MY4722)

2. Perform the post-repair adjustments and performance tests that pertain to this removal procedure.

Figure 3-18 A13 I/Q MUX (E8267D Standard or with Option 015) (Serial Prefixes
<US4722/MY4722)

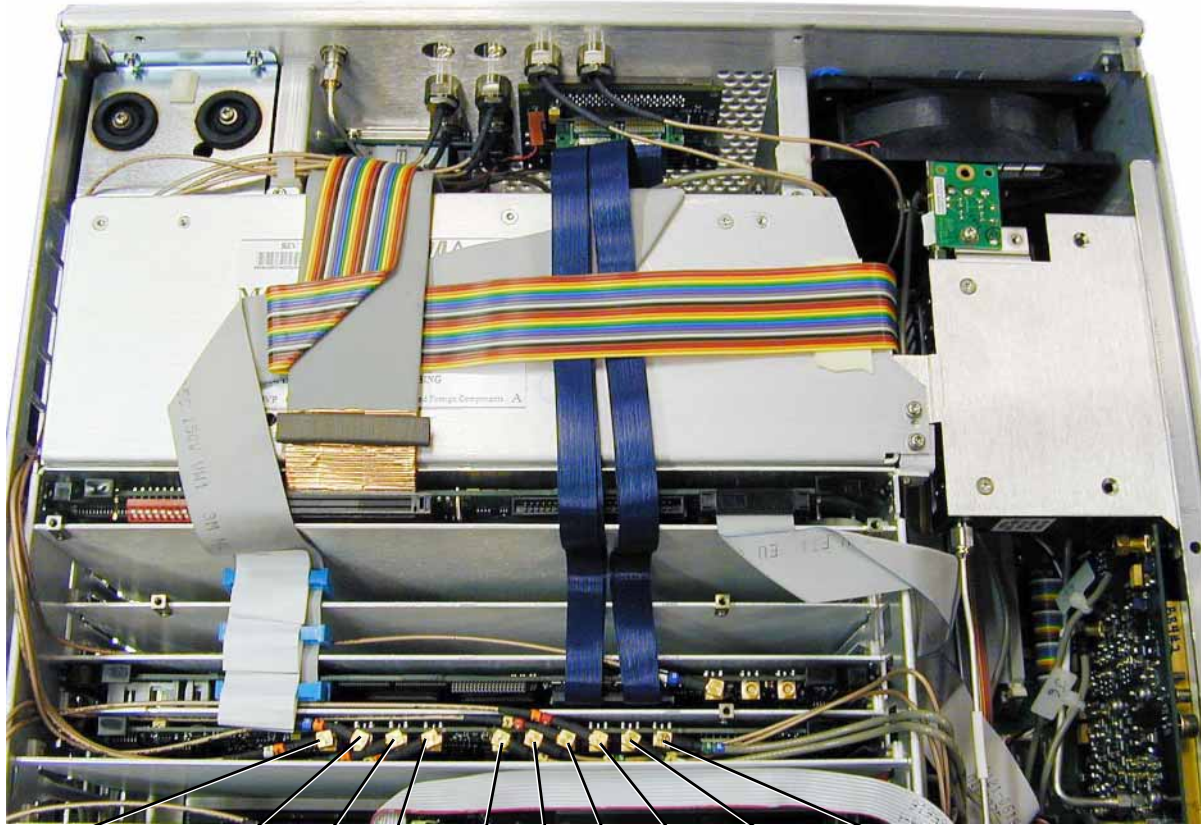

W56/A13J14
W57/A13J13
W58/A13J12
W59/A13J11
W60/A13J10
W61/A13J9
W50/A13J8
W62/A13J6
W49/A13J7
W63/A13J5

A13 I/Q MUX (E8267D Standard or with Option H16/016) (Serial Prefixes >=US4722/MY4722)

Tools Required

- T-10 driver
- needle-nose pliers

Removal Procedure

Refer to **Figure 3-19** for this procedure.

1. Disconnect the power cord.
2. Remove the covers from the signal generator. Refer to “**Outer Instrument Cover**” on page 6 and “**Inner Instrument Cover**” on page 8.
3. Position the signal generator with the front panel facing you.
4. Using the T-10 driver, remove the four screws from the Baseband Generator cover.
5. Using the needle-nose pliers, disconnect the following flexible cables:
 - W63 from A13J5
 - W62 from A13J6
 - W49 from A13J7
 - W50 from A13J8
 - W131 from A13J9
 - W133 from A13J10
 - W59 from A13J11
 - W58 from A13J12
 - W57 from A13J13
 - W56 from A13J14
 - W123 from A13J15
 - W124 from A13J16
 - W127 from A13J17
 - W128 from A13J18
 - W125 from A13J19
 - W126 from A13J20
 - W129 from A13J21

Assembly Replacement
A13 I/Q MUX (E8267D Standard or with Option H16/016) (Serial Prefixes
>=US4722/MY4722)

– W130 from A13J22

6. Lift the retention levers and disconnect the A13 I/Q MUX from the A31 Motherboard.
7. Lift the A13 I/Q MUX out of the slot.

Replacement Procedure

1. Reverse the order of the removal procedure. (See the internal cover overlay for cable color codes.)
2. Perform the post-repair adjustments and performance tests that pertain to this removal procedure.

Figure 3-19 A13 I/Q MUX (E8267D Standard or with Option 016) (Serial Prefixes
>US4722/MY4722)

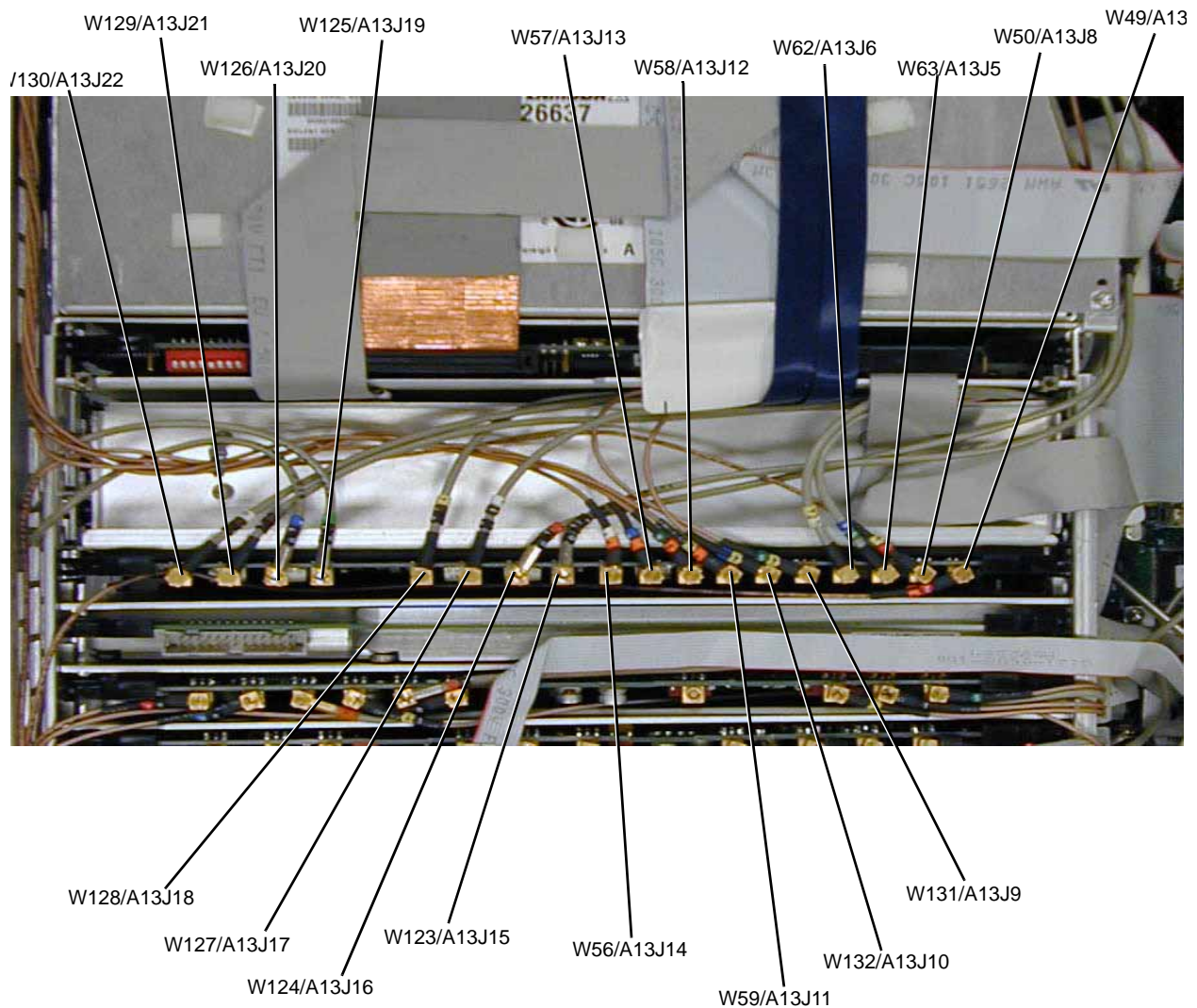

A14 Baseband Generator (E8267D Only)

Tools Required

- T-10 driver
- needle-nose pliers

Removal Procedure

Refer to **Figure 3-20** for this procedure.

1. Disconnect the power cord.
2. Remove the covers from the signal generator. Refer to “**Outer Instrument Cover**” on page 6 and “**Inner Instrument Cover**” on page 8.
3. Position the signal generator with the front panel facing you.
4. Using the T-10 driver, remove the four screws from the Baseband Generator cover.
5. Using the needle-nose pliers, disconnect the W65 flexible cable from A14J800.
6. Disconnect the W64 ribbon cable from A14J13.
7. Disconnect the W90 ribbon cable from A14J21 (Option 602 only).
8. Lift the retention levers and disconnect the A14 Baseband Generator from the A31 Motherboard.
9. Lift the A14 Baseband Generator out of the slot.

Replacement Procedure

1. Reverse the order of the removal procedure.
2. Perform the post-repair adjustments and performance tests that pertain to this removal procedure.

Assembly Replacement
A14 Baseband Generator (E8267D Only)

Figure 3-20 A14 Baseband Generator

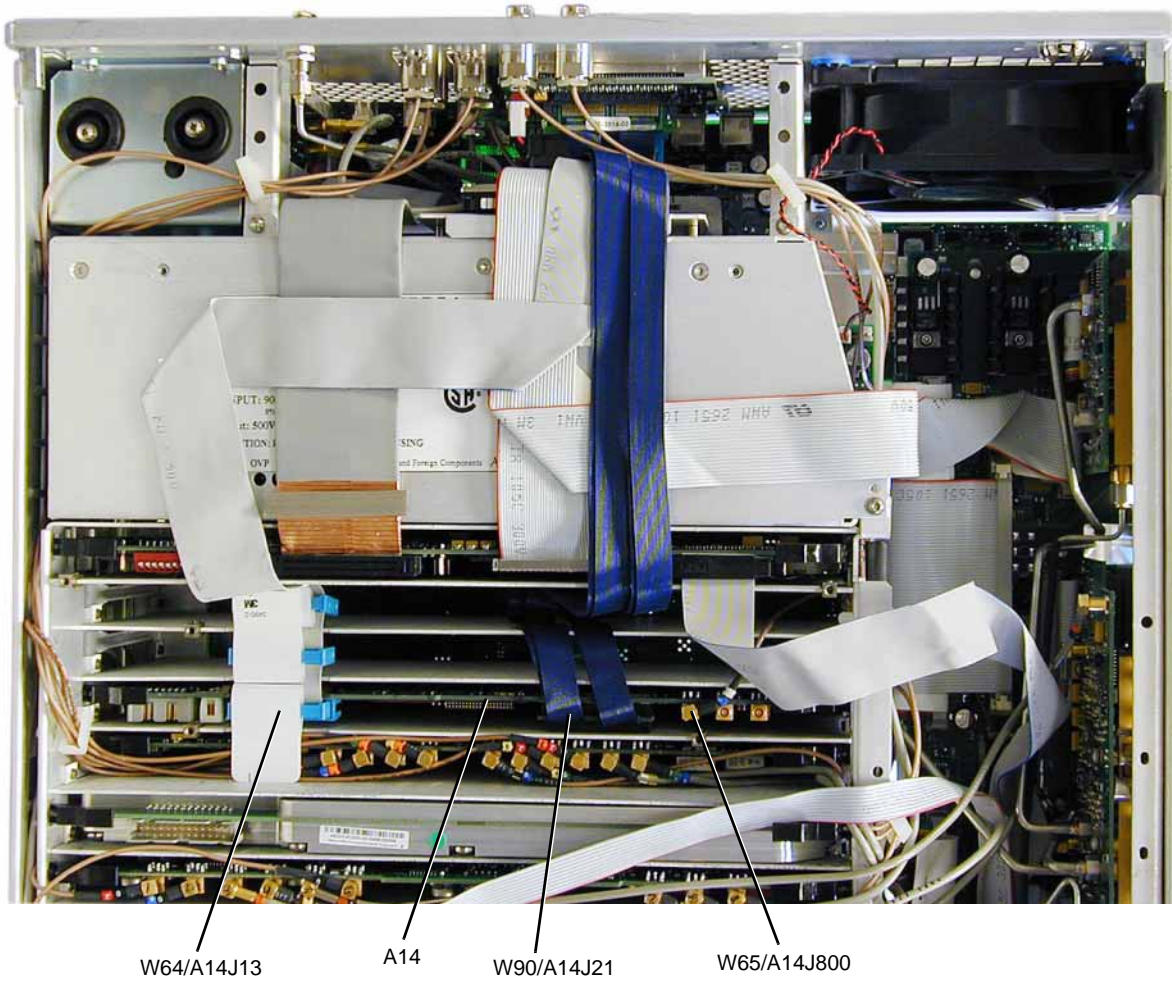

A17 Baseband Generator Interface (E8267D Only)

Tools Required

- 5.0 mm hex–nut driver
- 9/16” hex–nut driver
- needle–nose pliers

Removal Procedure

Refer to **Figure 3-21** for this procedure.

1. Disconnect the power cord.
2. Remove the covers from the signal generator. Refer to “**Outer Instrument Cover**” on page 6 and “**Inner Instrument Cover**” on page 8.
3. Remove the rear panel. Refer to “**Rear Panel (Standard)**” on page 108 or “**Rear Panel (Option 1EM)**” on page 111.
4. Disconnect the W64 ribbon cable from A17P2.
5. Disconnect the W90 ribbon cable from A17P1.
6. Using the needle–nose pliers, disconnect the W68 wire cable from A17P4.
7. Using the 9/16” hex–nut driver, remove the nuts and washers securing the four BNC connectors (1) on the rear panel.
8. Using the 5.0 mm driver, remove the hex screws (2) and washers that secure the A17 Baseband Generator Interface to the rear panel.
9. Remove the A17 Baseband Generator Interface.

Replacement Procedure

1. Reverse the order of the removal procedure.
2. Torque all hex screws to 9 in–lbs.
3. Perform the post–repair adjustments and performance tests that pertain to this removal procedure.

Figure 3-21 A17 Rear Panel Interface Board

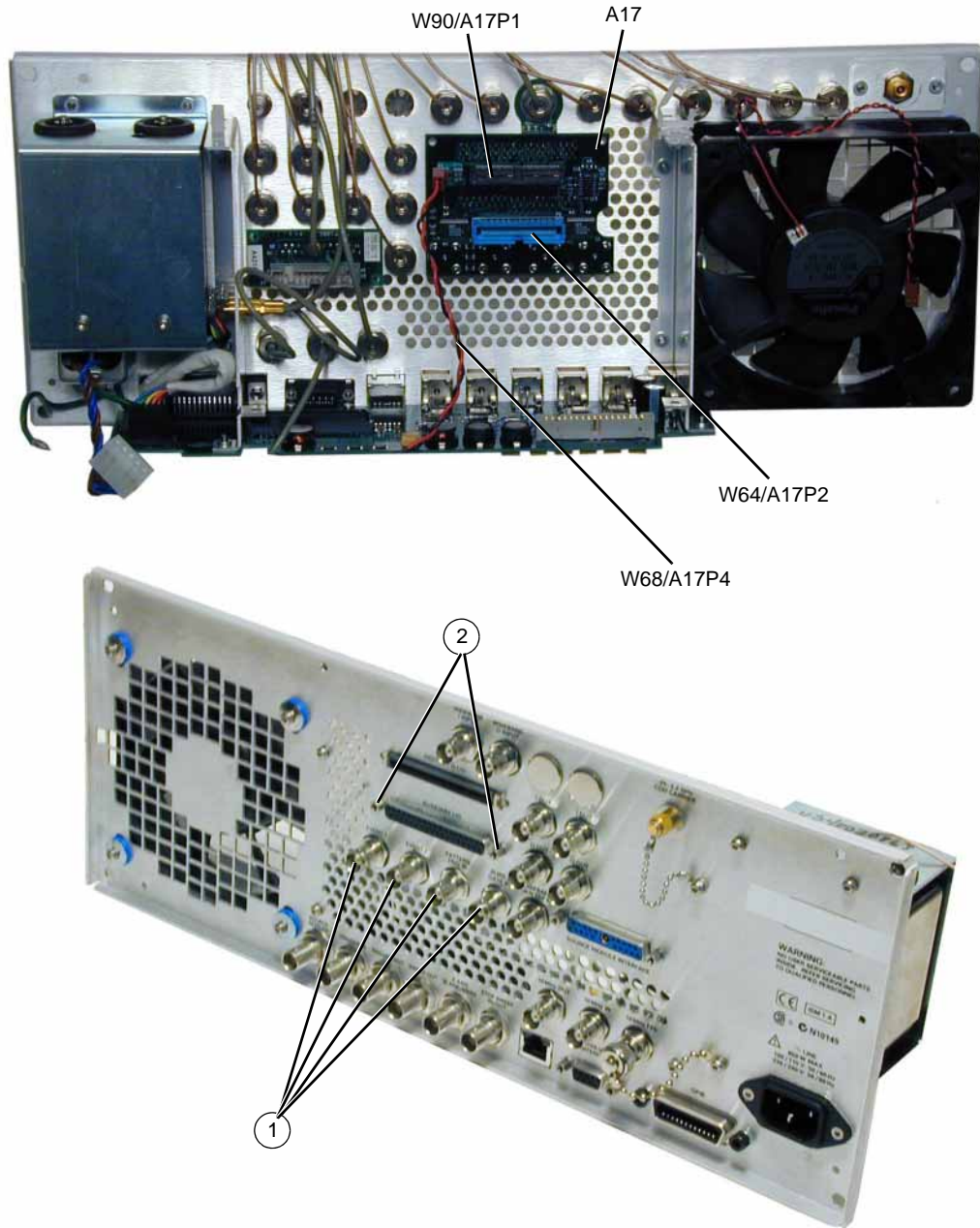

p2_a17

A18 CPU

Tools Required

- T-10 driver (E8267D only)

Removal Procedure

Refer to **Figure 3-22** for this procedure.

1. Disconnect the power cord.
2. Remove the covers from the signal generator. Refer to “**Outer Instrument Cover**” on page 6 and “**Inner Instrument Cover**” on page 8.
3. Position the signal generator with the front panel facing you.
4. Using the T-10 driver, remove the four screws from the Baseband Generator cover (E8267D Only).
5. Disconnect the following ribbon cables:
 - W19 from A18J2
 - W66 from A18P2 (E8267D only)
 - W18 from A18J1
 - W64 from A14J13 (E8267D only)
 - W90 from A14J21 (E8267D only)
6. Lift the retention levers and disconnect the A18 CPU from the A31 Motherboard.
7. Lift the A18 CPU out of the slot.

Replacement Procedure

1. To Install the CPU, reverse the order of the removal procedure.
2. Perform the post-repair CPU Configuration process.
3. Perform the A18 CPU post-repair adjustments and performance tests.

Assembly Replacement
A18 CPU

Figure 3-22 A18 CPU

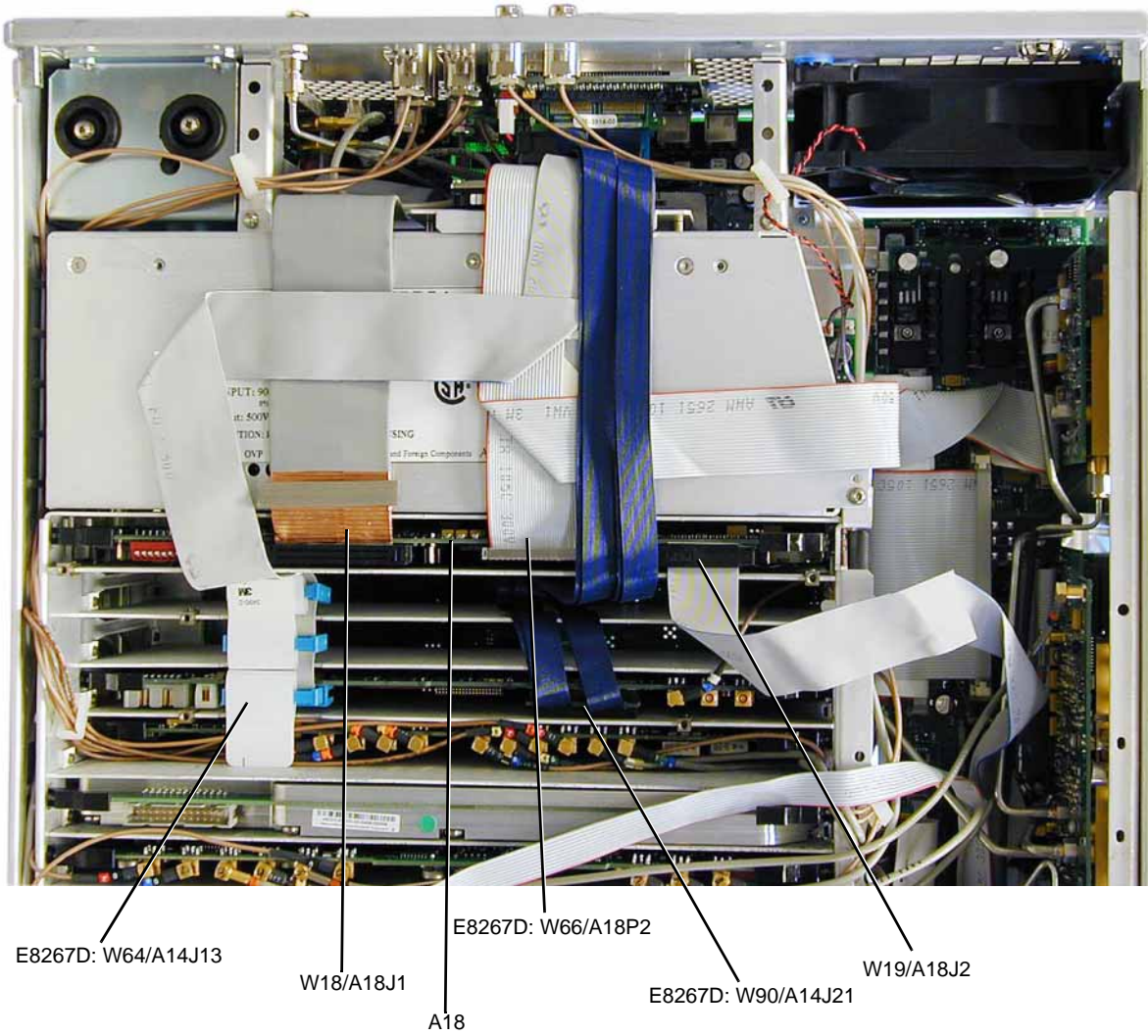

A18BT1

WARNING This battery contains lithium. Do not incinerate or puncture this battery. Do not install this battery backwards. To dispose of the battery in a safe manner, refer to [“Lithium Battery Disposal” on page 4](#).

Tools Required

- T-10 driver (E8267D only)
- flat-head screw driver

Removal Procedure

Refer to [Figure 3-23](#) for this procedure.

1. Disconnect the power cord.
2. Remove the covers from the signal generator. Refer to [“Outer Instrument Cover” on page 6](#) and [“Inner Instrument Cover” on page 8](#).
3. Position the signal generator with the front panel facing you.
4. Using the T-10 driver, remove the four screws from the Baseband Generator cover.
5. Disconnect the following ribbon cables:
 - W19 from A18J2
 - W66 from A18P2 (E8267D only)
 - W18 from A18J1
 - W64 from A14J13 (E8267D only)
 - W90 from A14J21 (E8267D only)
6. Lift the retention levers and disconnect the A18 CPU from the A31 Motherboard.
7. Lift the A18 CPU out of the slot.
8. Using the flat-head screw driver, remove the A18BT1 by leveraging the battery out of the battery's socket.

Replacement Procedure

1. To install the battery, the positive side is aligned with the positive sign on the A18's battery clip.
2. Reverse the remaining steps of the removal procedure.

Assembly Replacement
A18BT1

3. Perform the post-repair adjustments and performance tests that pertain to this removal procedure.

Figure 3-23 A18BT1

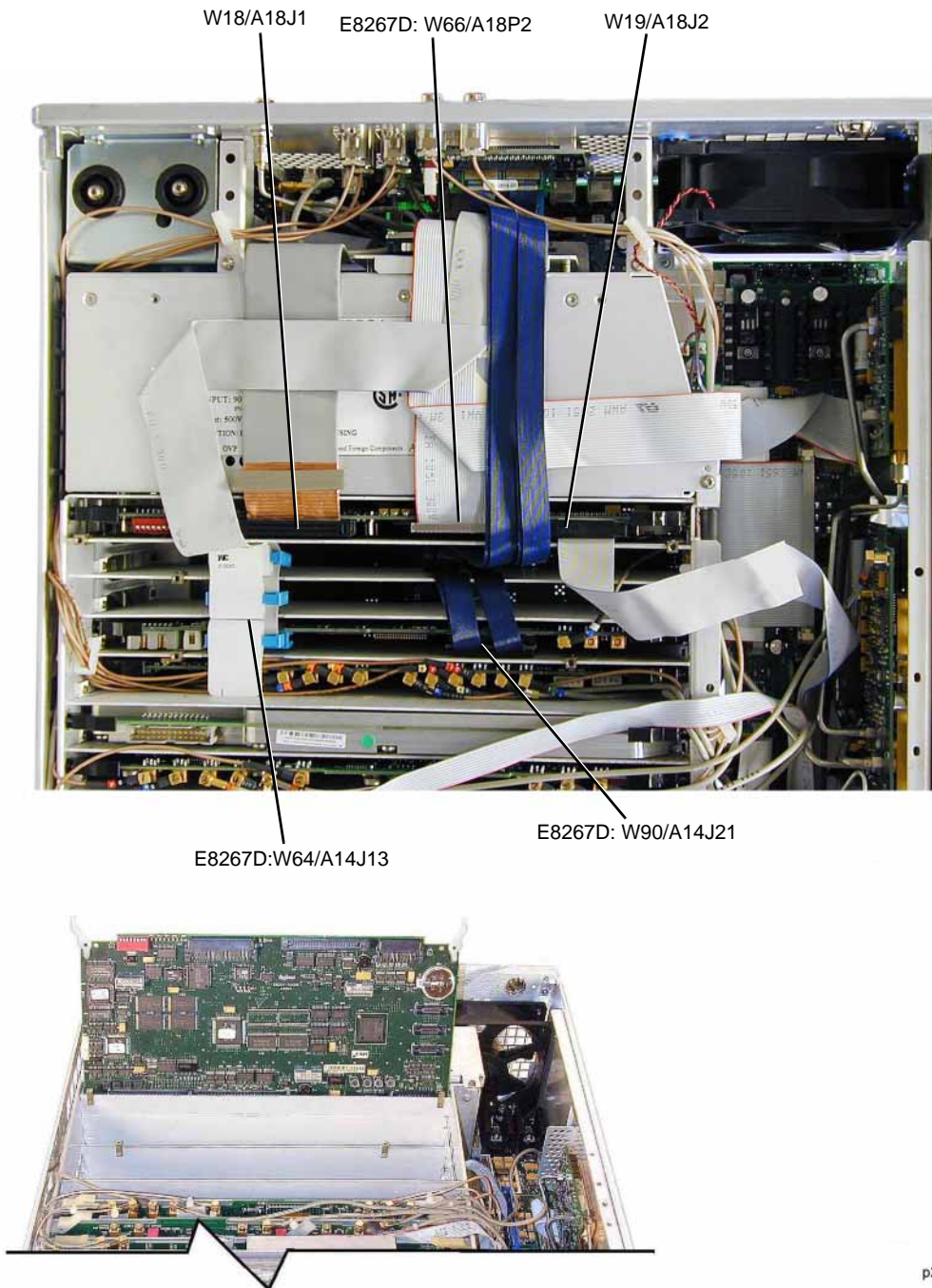

p2_a18bt1

A19 Power Supply

Tools Required

- T-10 driver
- needle-nose pliers

Removal Procedure

Refer to **Figure 3-24** for this procedure.

1. Disconnect the power cord.
2. Remove the covers from the signal generator. Refer to “**Outer Instrument Cover**” on page 6 and “**Inner Instrument Cover**” on page 8.
3. Position the signal generator with the A31 Motherboard facing you.
4. Disconnect the W20 ribbon cable from the A20 SMI.
5. Using the T-10 driver, remove the two screws (1) that secure the A19 Power Supply to the struts located on the bottom.
6. Using the T-10 driver, remove the three additional screws (2) that are attached to the bottom frame.
7. Using the needle-nose pliers, disconnect A22W1 from the power supply.
8. Using the T-10 driver, remove the screw securing the A22W2 to the A19 Power Supply.
9. Position the signal generator with the A31 Motherboard flat on the work surface and the rear panel facing you.
10. Disconnect the following ribbon cables:
 - W64 from A14J13 (E8267D only)
 - W90 from A14J21 (E8267D only)
 - W66 from A18P2 (E8267D only)
 - W18 from A18J1
11. Using the T-10 driver, remove the two screws (3) that secure the A19 Power Supply to the struts located on the top and an additional screw (4) located on the top frame.
12. Move W20 to the side and remove the A19 Power Supply from the signal generator’s chassis.
13. Remove the screw that attaches the A34 Internal Hard Drive to the A19 Power Supply
(For E8267D with serial prefixes <US4829/MY4829 only).

Replacement Procedure

- 1. Reverse the order of the removal procedure.**
- 2. Torque all T-10 screws to 9 in-lbs.**
- 3. Perform the post-repair adjustments and performance tests that pertain to this removal procedure.**

Figure 3-24 A19 Power Supply Removal

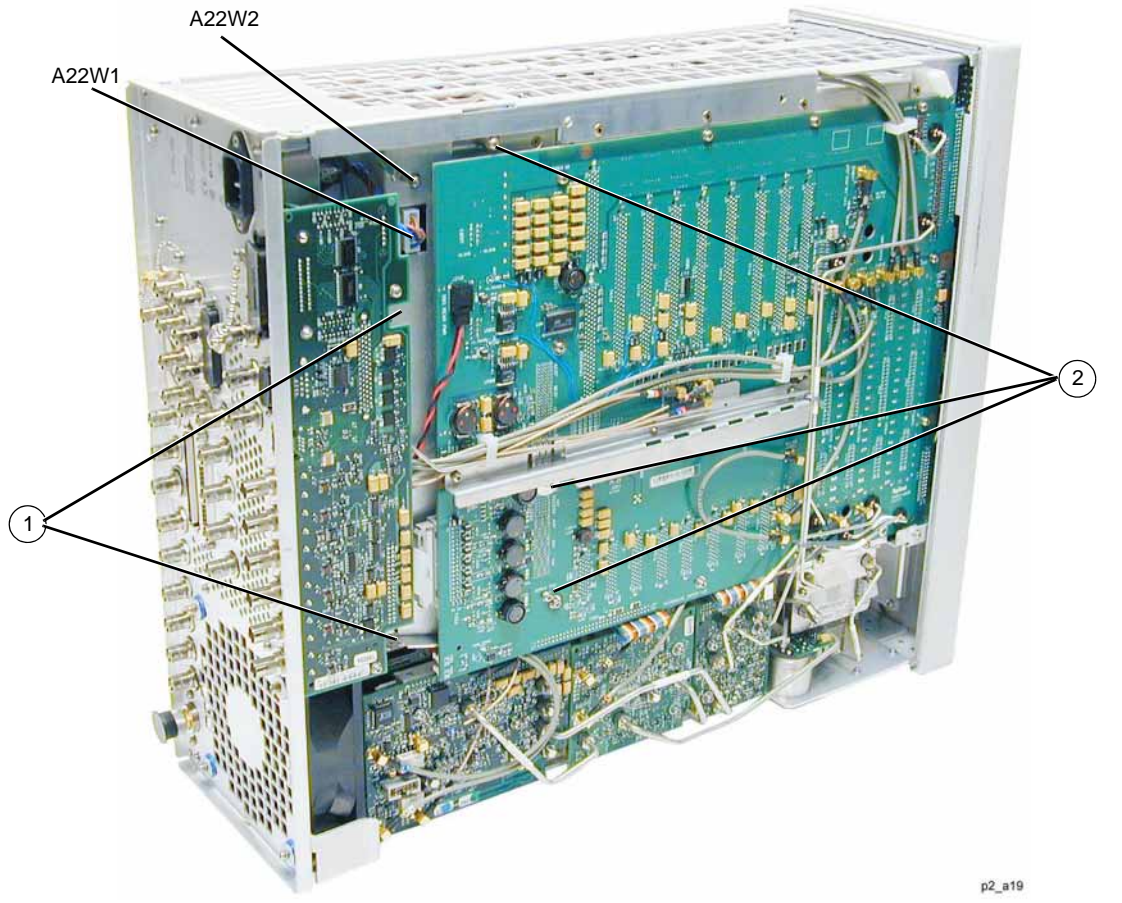

p2_a19

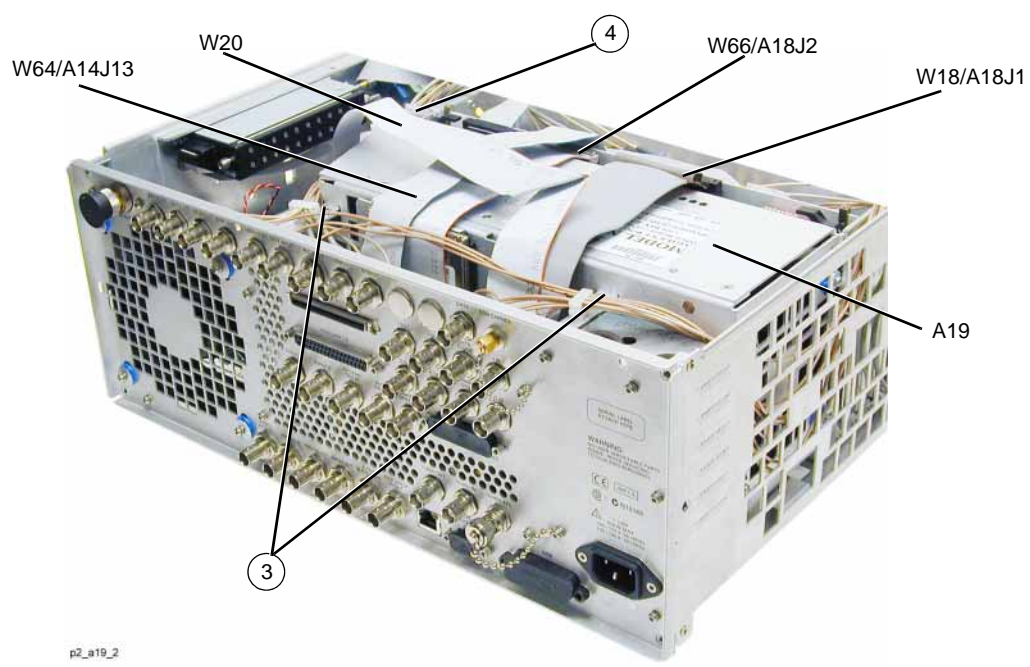

p2_a19_2

A20 SMI (Source Module Interface)

Tools Required

- 5.0 mm hex–nut driver
- needle–nose pliers

Removal Procedure

Refer to **Figure 3-25** for this procedure.

1. Disconnect the power cord.
2. Remove the covers from the signal generator. Refer to “**Outer Instrument Cover**” on page 6 and “**Inner Instrument Cover**” on page 8.
3. Using the needle–nose pliers, disconnect the W55 flexible cable from the A10 ALC J303.
4. Disconnect the W20 ribbon cable from the A26 MID J20.
5. Using the 5.0 mm driver, remove the hex screws (1) and washers that secure the A20 SMI to the rear panel.
6. Remove the A20 SMI.

Replacement Procedure

1. Reverse the order of the removal procedure.
2. Torque all hex screws to 9 in–lbs.
3. Perform the post–repair adjustments and performance tests that pertain to this removal procedure.

Figure 3-25 A20 SMI

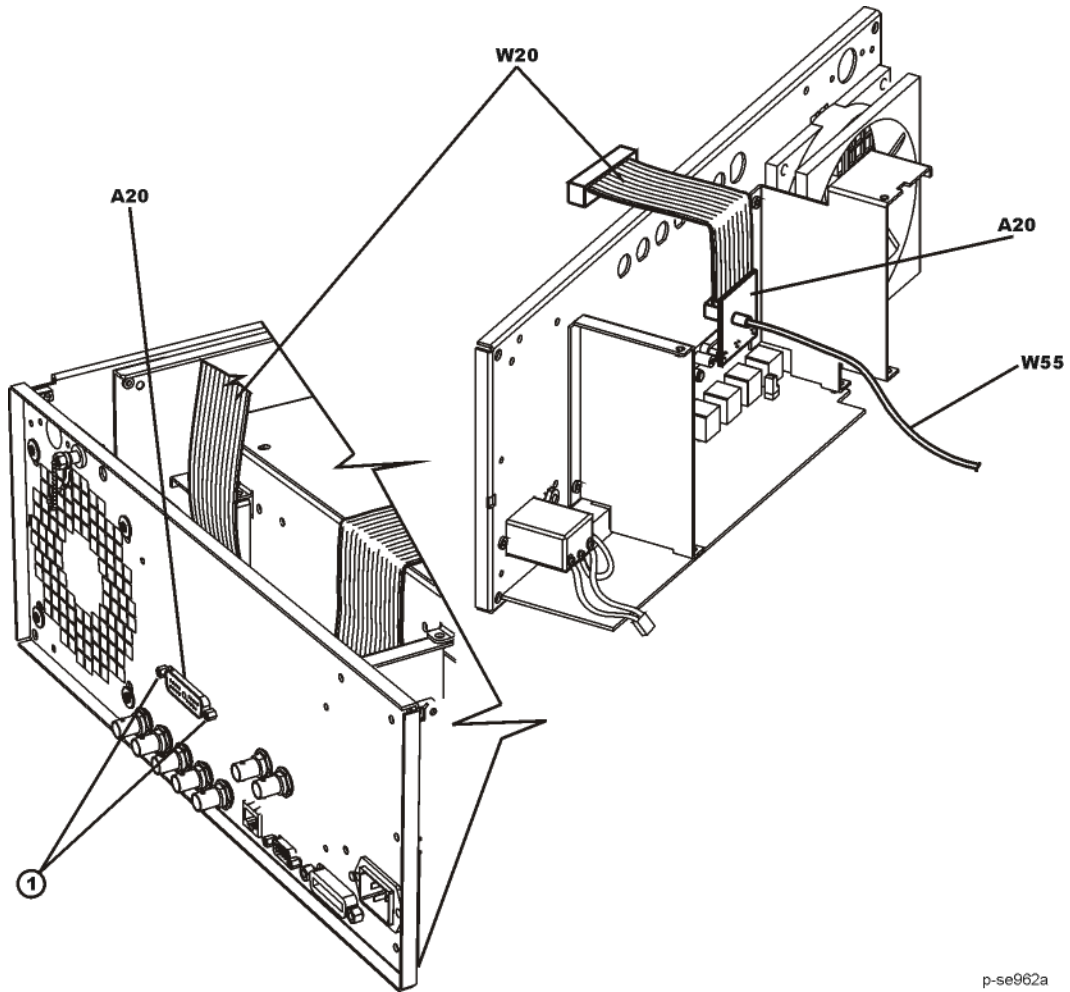

p-se962a

A21 Rear-Panel Interface

Tools Required

- T-10 driver
- 9/16" hex-nut driver
- 5.0 mm hex-nut driver
- 7.0 mm hex-nut driver
- needle-nose pliers

Removal Procedure

Refer to **Figure 3-26** for this procedure.

1. Disconnect the power cord.
2. Remove the covers from the signal generator. Refer to **"Outer Instrument Cover" on page 6** and **"Inner Instrument Cover" on page 8**.
3. Remove the rear panel. Refer to **"Rear Panel (Standard)" on page 108** or **"Rear Panel (Option 1EM)" on page 111**.
4. Using the 9/16" hex-nut driver, remove the nuts and washers securing the six BNC connectors (1) at the base of the rear panel.
5. Using the 5.0 mm hex-nut driver, remove the screws (2) from the RS-232 port.
6. Using the 7.0 mm hex-nut driver, remove the screws (3) from the GPIB port.
7. Using the T-10 driver, remove the two screws (4) from the bottom of the A21 Rear Panel Interface.
8. Disconnect the B1 Fan cable (5) from A31P251.
9. If you have Option UNR/UNX, disconnect the A32 10 MHz Crystal Oscillator (Option UNR/UNX) cable from A21P2.
10. Remove the A21 Rear Panel Interface.

Replacement Procedure

1. Reverse the order of the removal procedure.
2. Torque all T-10 screws to 9 in-lbs.
3. Torque all hex-nuts to 9 in-lbs.
4. Torque all BNC nuts to 21 in-lbs.

5. Perform the post-repair adjustments and performance tests that pertain to this removal procedure.

Figure 3-26 A21 Rear Panel Interface

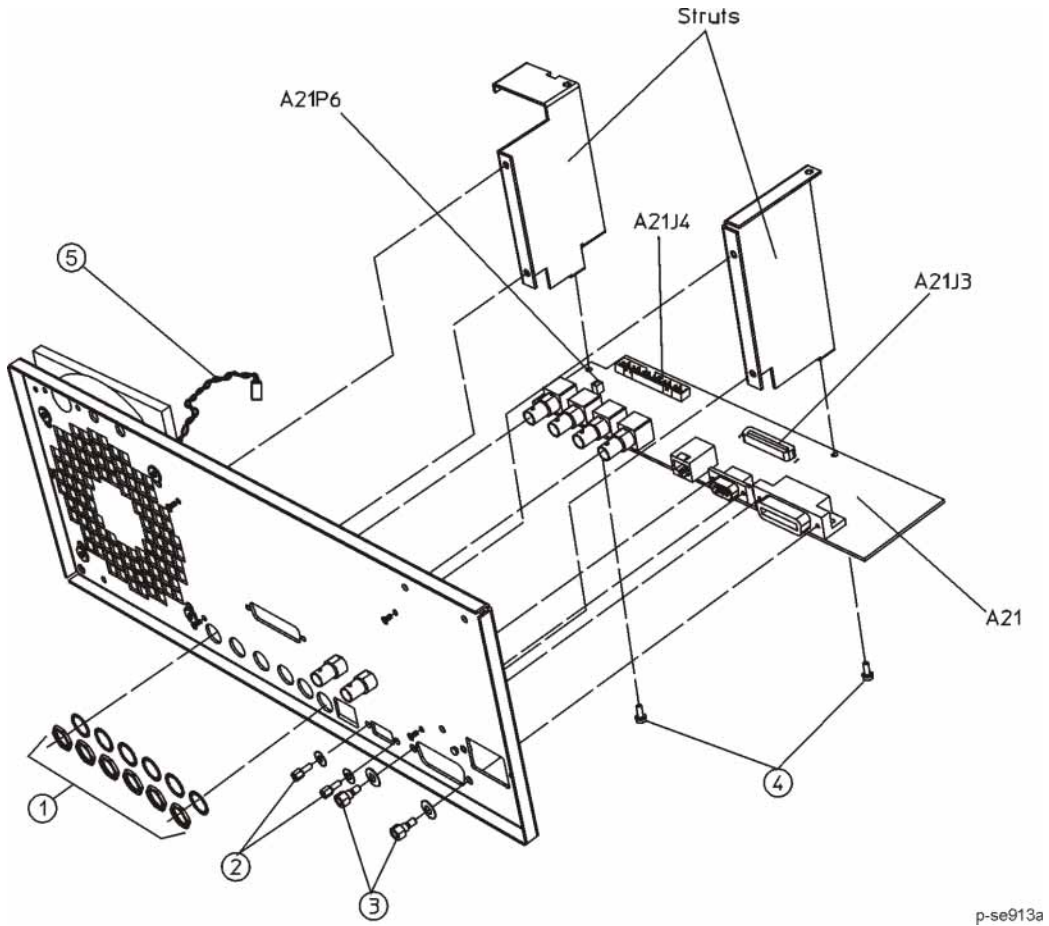

A22 Line Module

Tools Required

- T-10 driver
- 5.0 mm wrench
- needle-nose pliers

Removal Procedure

Refer to **Figure 3-27** for this procedure.

1. Disconnect the power cord.
2. Remove the covers from the signal generator. Refer to “**Outer Instrument Cover**” on page 6 and “**Inner Instrument Cover**” on page 8.
3. Position the signal generator with the rear panel facing you.
4. If the signal generator has Option UNR/UNIX, remove the A32 10 MHz Crystal Oscillator. Refer to “**A32 10 MHz Crystal Oscillator**” on page 102 to remove the assembly.
5. Using the T-10 driver, remove the two screws (1) that attach the A22 Line Module to the rear panel.
6. Using the 5.0 mm wrench, remove the nut (2) and washer from the grounding screw connecting A22W2 to the rear panel.
7. Using the T-10 driver, remove the screw (3) that attaches the A22W2 to the bottom of the A19 Power Supply (E8267D only).
8. Using the needle-nose pliers, disconnect the A22W1 from the bottom of the A19 Power Supply.
9. Remove the A22 Line Module

Replacement Procedure

1. Reverse the order of the removal procedure.
2. Torque all T-10 screws to 9 in-lbs.
3. Torque all nuts to 9 in-lbs.
4. Perform the post-repair adjustments and performance tests that pertain to this removal procedure.

Figure 3-27 A22 Line Module Removal

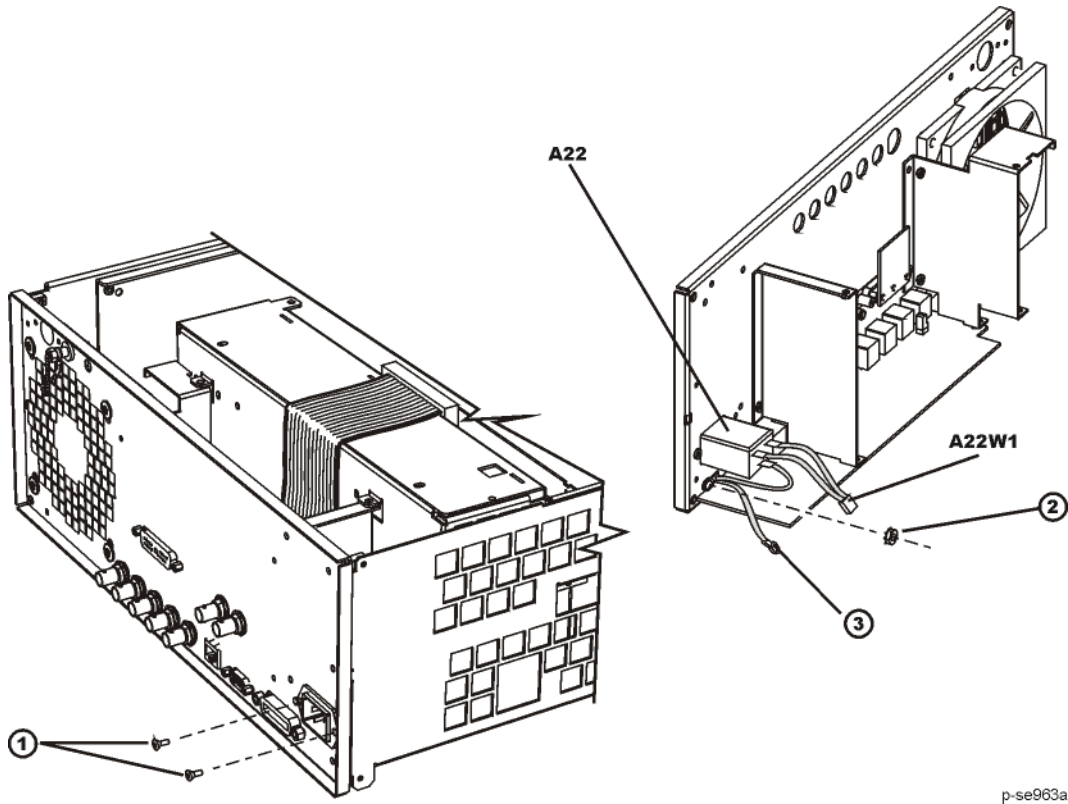

p-se963a

A23 Lowband Coupler/Detector

Tools Required

- T-10 driver
- 5/16" open-ended wrench
- wire cutters

Removal Procedure

Refer to **Figure 3-28** for this procedure.

1. Disconnect the power cord.
2. Remove the covers from the signal generator. Refer to **"Outer Instrument Cover" on page 6** and **"Inner Instrument Cover" on page 8**.
3. Position the signal generator so that the A31 Motherboard is facing you and the RF deck is on top.
4. Using the 5/16" open-ended wrench, disconnect the W27 RF cable from the A23 Lowband Coupler/Detector.
5. Using the wire cutters, cut the tie wrap that secures the W27 RF cable to the A23 Lowband Coupler/Detector.
6. Using the 5/16" open-ended wrench, disconnect the following RF cable according to the signal generator you have.

E8257D & E8663D: Disconnect the W37 RF cable from the A23 Lowband Coupler/Detector.

E8267D: Disconnect the W75 RF cable from the A23 Lowband Coupler/Detector.
7. Using the T-10 driver, remove the two screws that attach the A23 Lowband Coupler/Detector to the side panel.
8. Disconnect the W28 ribbon cable from the A23 Lowband Coupler/Detector (not shown in **Figure 3-28**).
9. Disconnect the W14 flexible cable from the A23 Lowband Coupler/Detector (not shown in **Figure 3-28**).
10. Remove the A23 Lowband Coupler/Detector.

Replacement Procedure

1. Reverse the order of the removal procedure.
2. Torque all T-10 screws to 9 in-lbs.

3. Torque all RF connectors to 8 in-lbs.
4. Perform the post-repair adjustments and performance tests that pertain to this removal procedure.

Figure 3-28 A23 Lowband Coupler/Detector

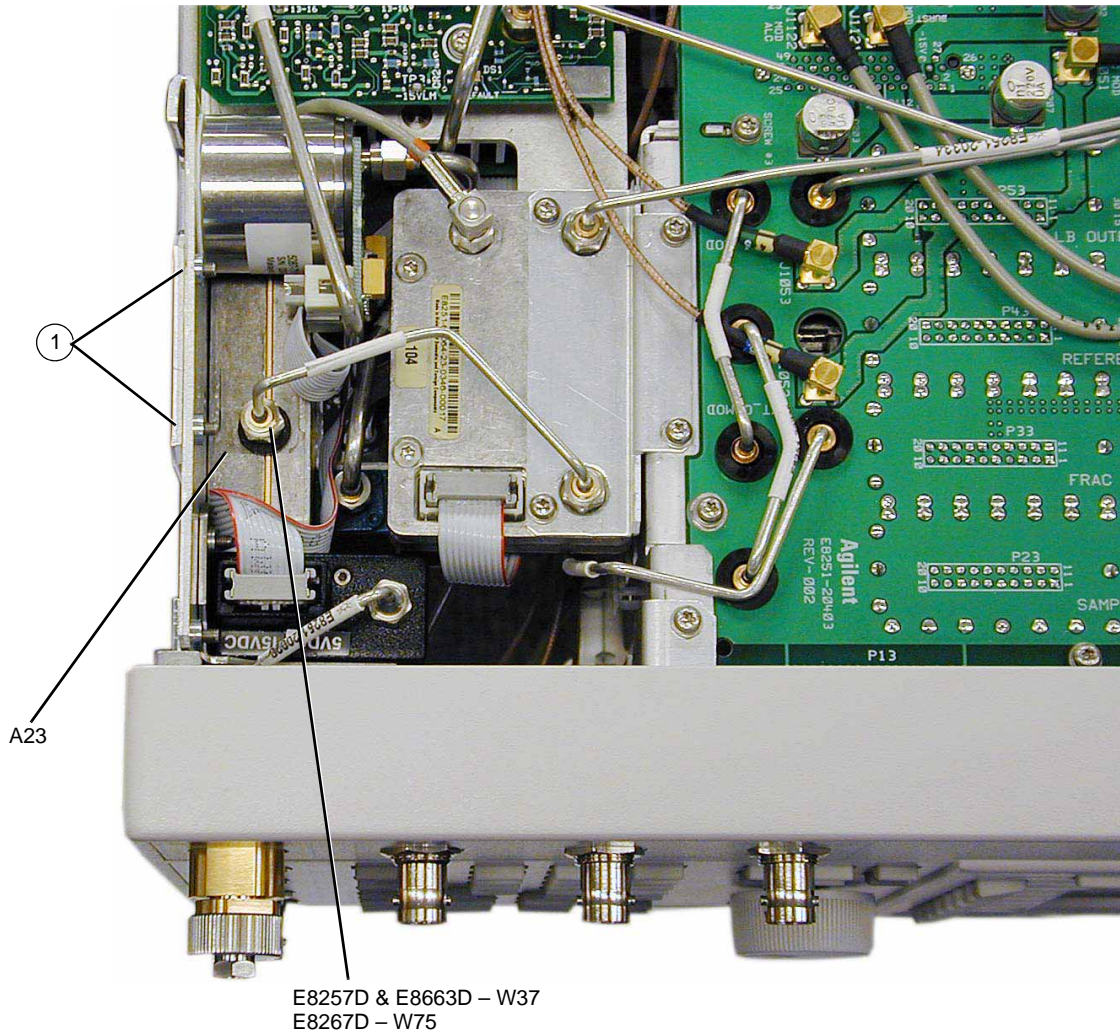

A23

E8257D & E8663D – W37
E8267D – W75

A24 20 GHz Highband Coupler (Options 503, 509, 520, and 521)

Tools Required

- T-10 driver
- 5/16" open-ended wrench

Removal Procedure

Refer to [Figure 3-29](#), [Figure 3-30](#), [Figure 3-31](#) or [Figure 3-32](#) for this procedure.

1. Disconnect the power cord.
2. Remove the covers from the signal generator. Refer to [“Outer Instrument Cover” on page 6](#) and [“Inner Instrument Cover” on page 8](#).
3. Position the signal generator with the A31 Motherboard facing away from you and the RF deck on top.
4. Using the 5/16" open-ended wrench, disconnect the following assembly according to the signal generator you have.

E8257D & E8663D: Disconnect the A25 20 GHz Highband Detector from the A24 20 GHz Highband Coupler.

E8267D: Disconnect the A33 6dB PAD from the A24 20 GHz Highband Coupler.

5. Using the 5/16" open-ended wrench, disconnect the following RF cables according to the signal generator you have.

Standard:

Options 503, 509, and 520: Disconnect W74 and W24 or W133 (instruments without Option 1E1, not shown) RF cables from the A24 20 GHz Highband Coupler's input and output.

Option 521: Disconnect W142 and W144 RF cables from the A24 20 GHz Highband Coupler's input and output.

Option 1EM:

Options 503, 509, and 520: Disconnect W71 and W72 RF cables from the A24 20 GHz Highband Coupler's input and output.

Option 521: Disconnect W143 and W147 RF cables from the A24 20 GHz Highband Coupler's input and output.

6. Using the T-10 driver, remove the two screws that connect the A25B Highband Detector Bias Board to the A24 20 GHz Highband Coupler.

7. Using the T-10 driver, remove the two screws that attach the coupler to the side panel.
8. Remove the A24 20 GHz Highband Coupler.

Replacement Procedure

1. Reverse the order of the removal procedure.
2. Torque all T-10 screws to 9 in-lbs.
3. Torque all RF connectors to 8 in-lbs.
4. Perform the post-repair adjustments and performance tests that pertain to this removal procedure.

Figure 3-29 A24 20 GHz Highband Coupler (Options 503, 509, and 520 – Standard)

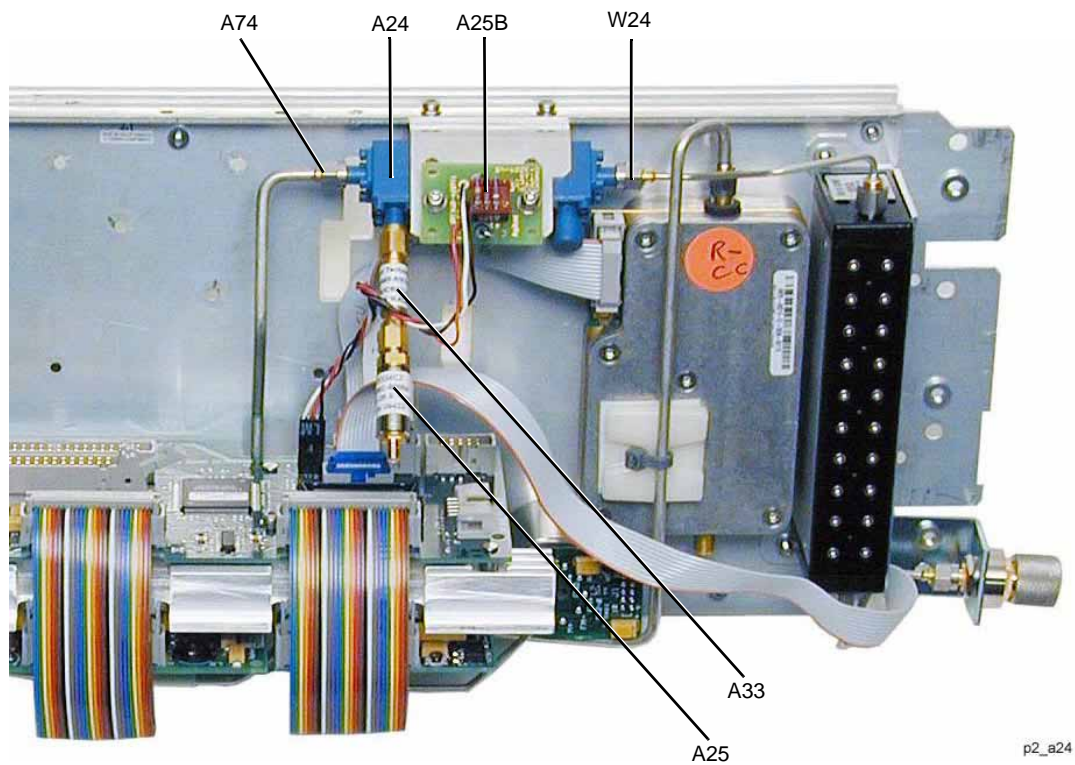

Assembly Replacement
A24 20 GHz Highband Coupler (Options 503, 509, 520, and 521)

Figure 3-30 A24 20 GHz Highband Coupler (Options 503, 509 and 520 – Option 1EM)

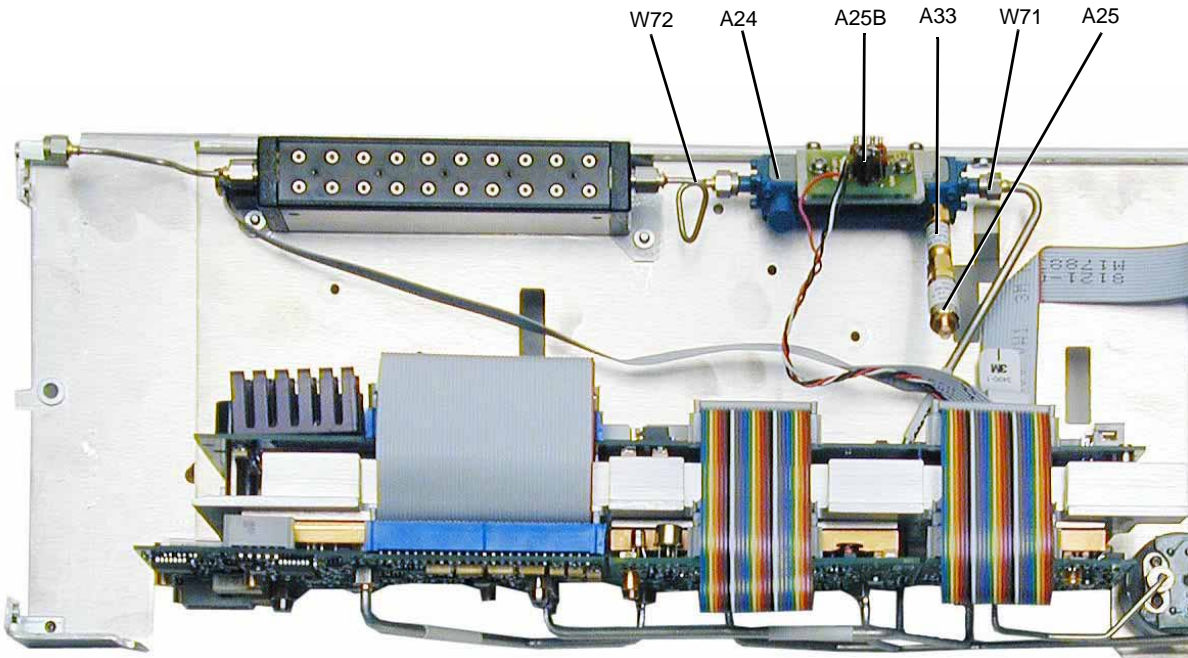

Assembly Replacement
A24 20 GHz Highband Coupler (Options 503, 509, 520, and 521)

Figure 3-31 A24 20 GHz Highband Coupler (Option 521 - Standard)

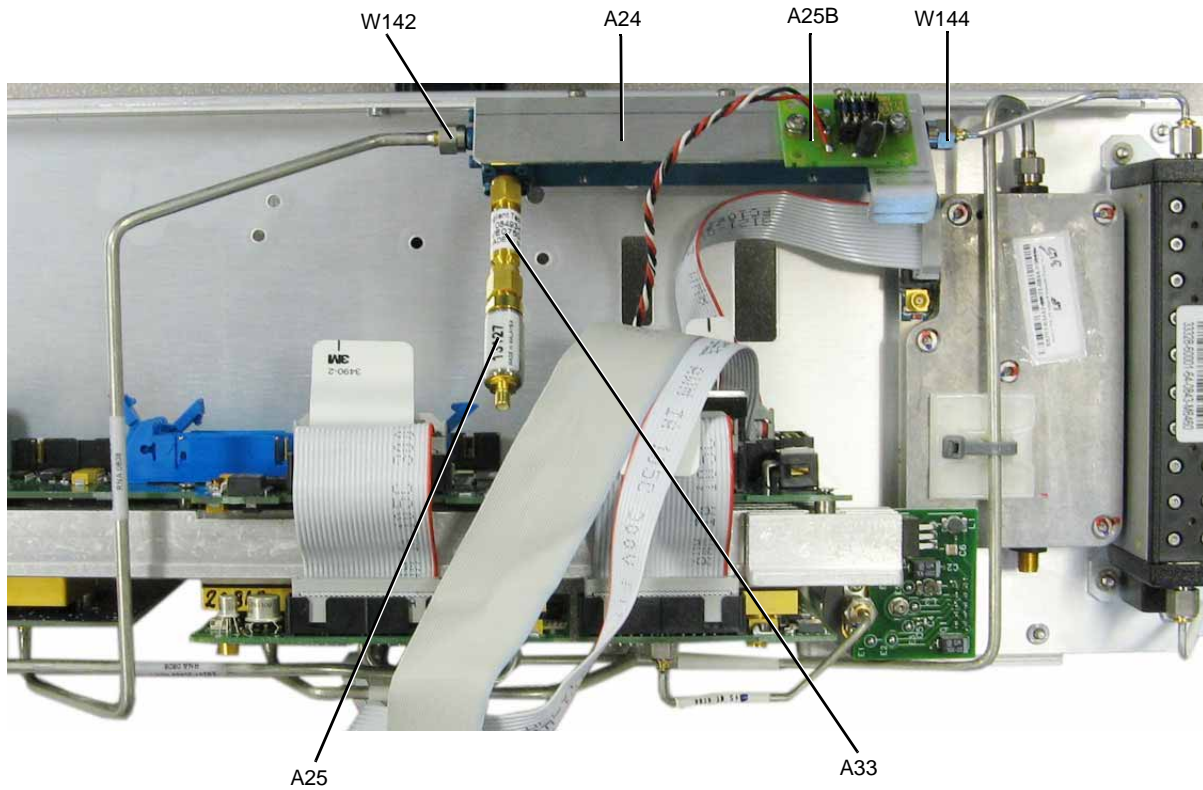
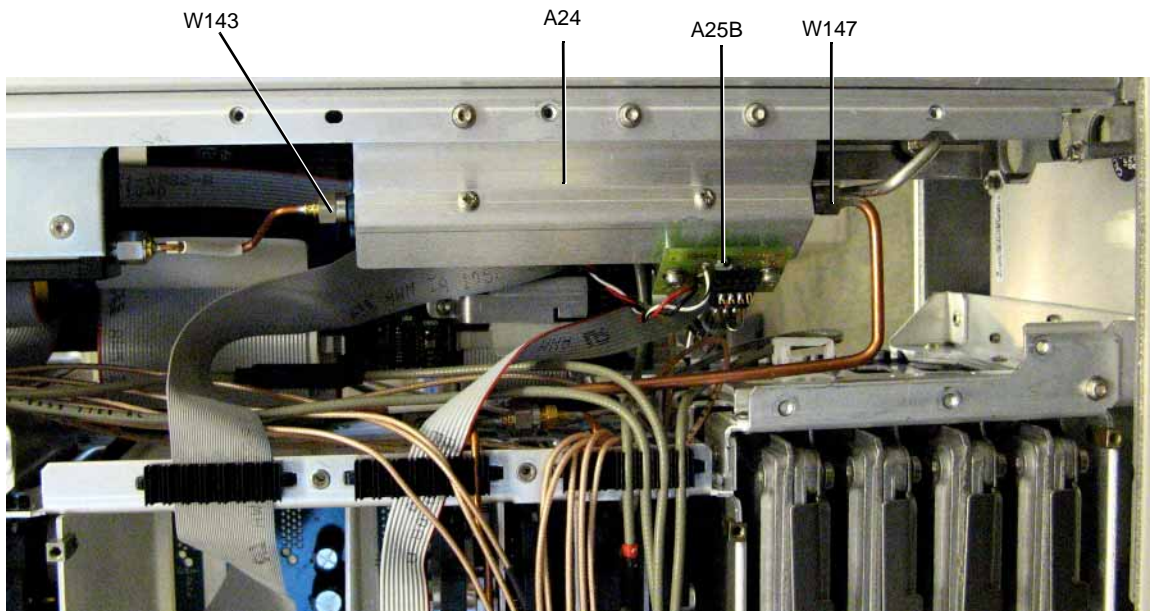

Figure 3-32 A24 20 GHz Highband Coupler (Option 521 - Option 1EM)



Assembly Replacement
A24 20 GHz Highband Coupler (Options 503, 509, 520, and 521)

This page intentionally left blank.

A24 40 GHz Highband Coupler (Option 540)

Tools Required

- T-10 driver
- 5/16" open-ended wrench

Removal Procedure

Refer to **Figure 3-33** and **Figure 3-34** for this procedure.

1. Disconnect the power cord.
2. Remove the covers from the signal generator. Refer to “**Outer Instrument Cover**” on page 6 and “**Inner Instrument Cover**” on page 8.
3. Position the signal generator with the A31 Motherboard facing away from you and the RF deck on top.
4. Using the 5/16" open-ended wrench, disconnect the A25 40 GHz Highband Detector from the A24 40 GHz Highband Coupler.
5. Using the 5/16" open-ended wrench, disconnect the following cables according to the signal generator you have.

Standard: Disconnect W30 and W24 or W26 (instruments without Option 1E1, not shown) RF cables from the A24 40 GHz Highband Coupler's input and output.

Option 1EM: Disconnect W71 and W72 RF cables from the A24 40 GHz Highband Coupler's input and output.

6. Using the T-10 driver, remove the two screws that connect the A25B Highband Detector Bias Board to the A24 40 GHz Highband Coupler.
7. Using the T-10 driver, remove the two screws that attach the coupler to the side panel.
8. Remove the A24 40 GHz Highband Coupler.

Replacement Procedure

1. Reverse the order of the removal procedure.
2. Torque all T-10 screws to 9 in-lbs.
3. Torque all RF connectors to 8 in-lbs.
4. Perform the post-repair adjustments and performance tests that pertain to this removal procedure.

Figure 3-33 A24 40 GHz Highband Coupler (Option 540 – Standard)

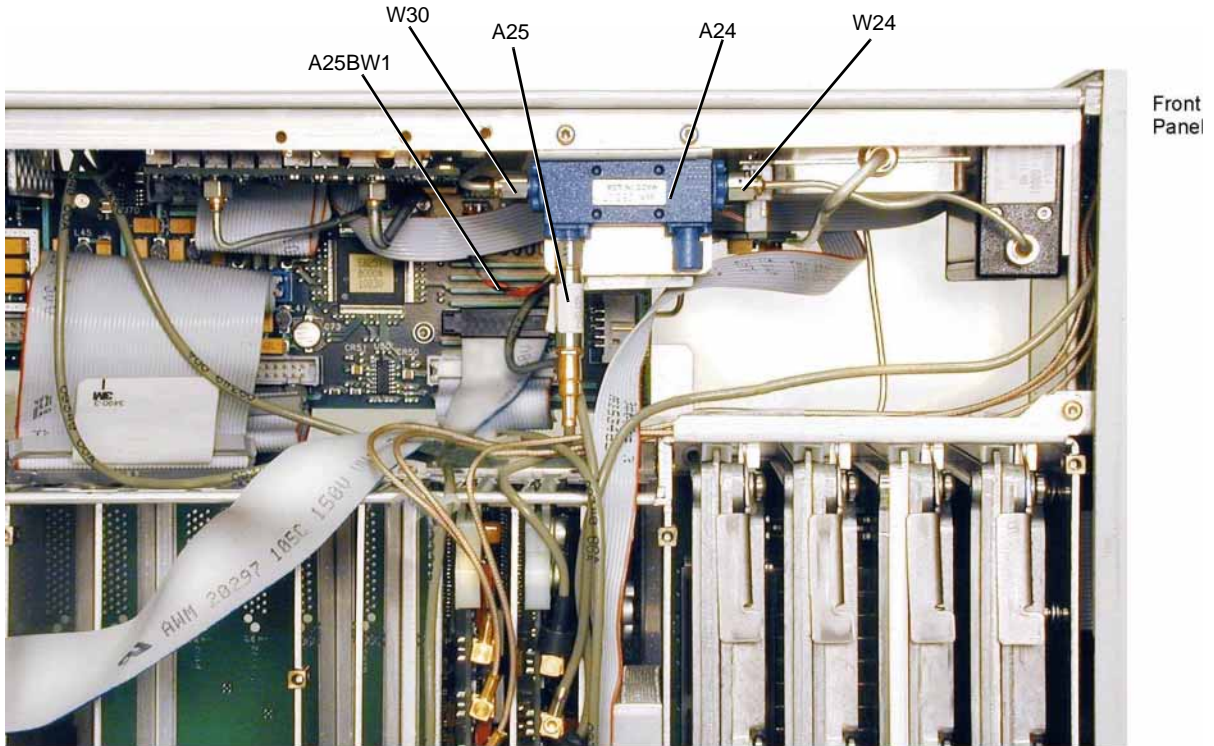

p-se959a

Figure 3-34 A24 40 GHz Highband Coupler (Option 540 – Option 1EM)

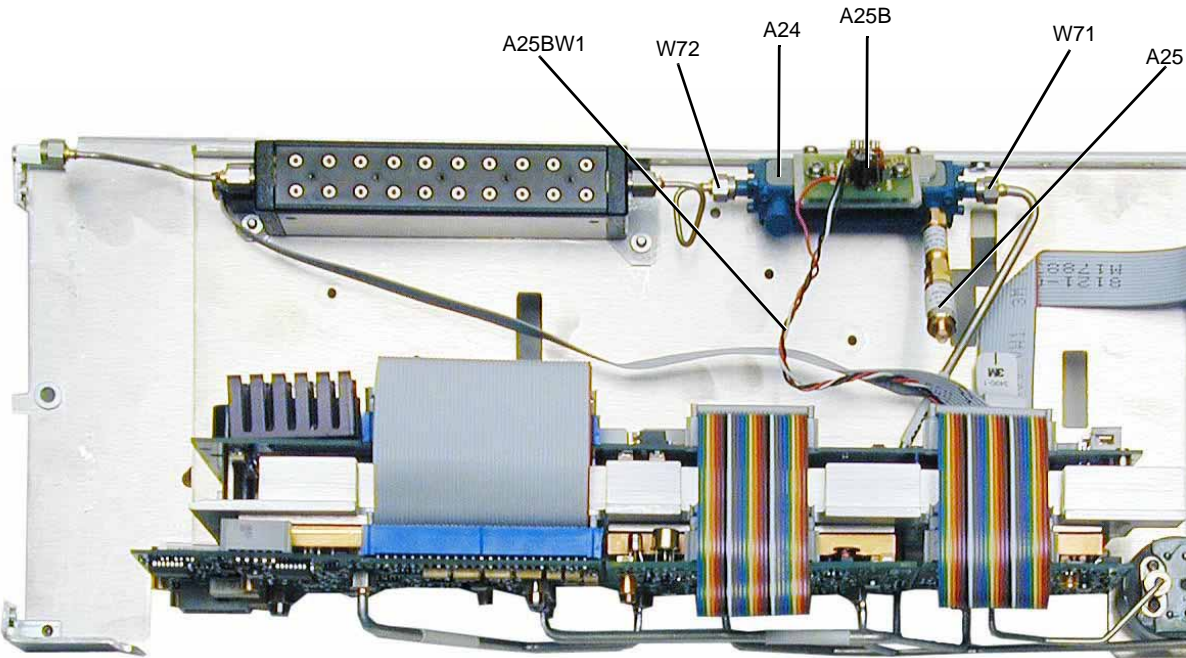

A24 50 GHz Highband Coupler (Options 532 and 544)

Tools Required

- T-10 driver
- 5/16" open-ended wrench

Removal Procedure

Refer to **Figure 3-35** and **Figure 3-36** for this procedure.

1. Disconnect the power cord.
2. Remove the covers from the signal generator. Refer to “**Outer Instrument Cover**” on page 6 and “**Inner Instrument Cover**” on page 8.
3. Position the signal generator with the A31 Motherboard facing away from you and the RF deck on top.
4. Using the 5/16" open-ended wrench, disconnect the A33 10dB PAD from the A24 50 GHz Highband Coupler
5. Using the 5/16" open-ended wrench, disconnect the following cables according to the signal generator you have.

Standard: Disconnect W102 and W24 or W26 (instruments without Option 1E1, not shown) RF cables from the A24 50 GHz Highband Coupler's input and output.

Option 1EM: Disconnect W102 and W93 RF cables from the A24 50 GHz Highband Coupler's input and output.

Option 1EM without Option 1E1: Disconnect W102 and W82 (not shown) RF cables from the A24 50 GHz Highband Couplers input and output.

6. Using the T-10 driver, remove the two screws that connect the A25B Highband Detector Bias Board to the A24 50 GHz Highband Coupler.
7. Using the T-10 driver, remove the two screws that attach the coupler to the side panel.
8. Remove the A24 50 GHz Highband Coupler.

Replacement Procedure

1. Reverse the order of the removal procedure.
2. Torque all T-10 screws to 9 in-lbs.
3. Torque all RF connectors to 8 in-lbs.
4. Perform the post-repair adjustments and performance tests that pertain to this removal procedure.

Assembly Replacement
A24 50 GHz Highband Coupler (Options 532 and 544)

Figure 3-35 A24 50 GHz Highband Coupler (Options 532 & 544 – Standard)

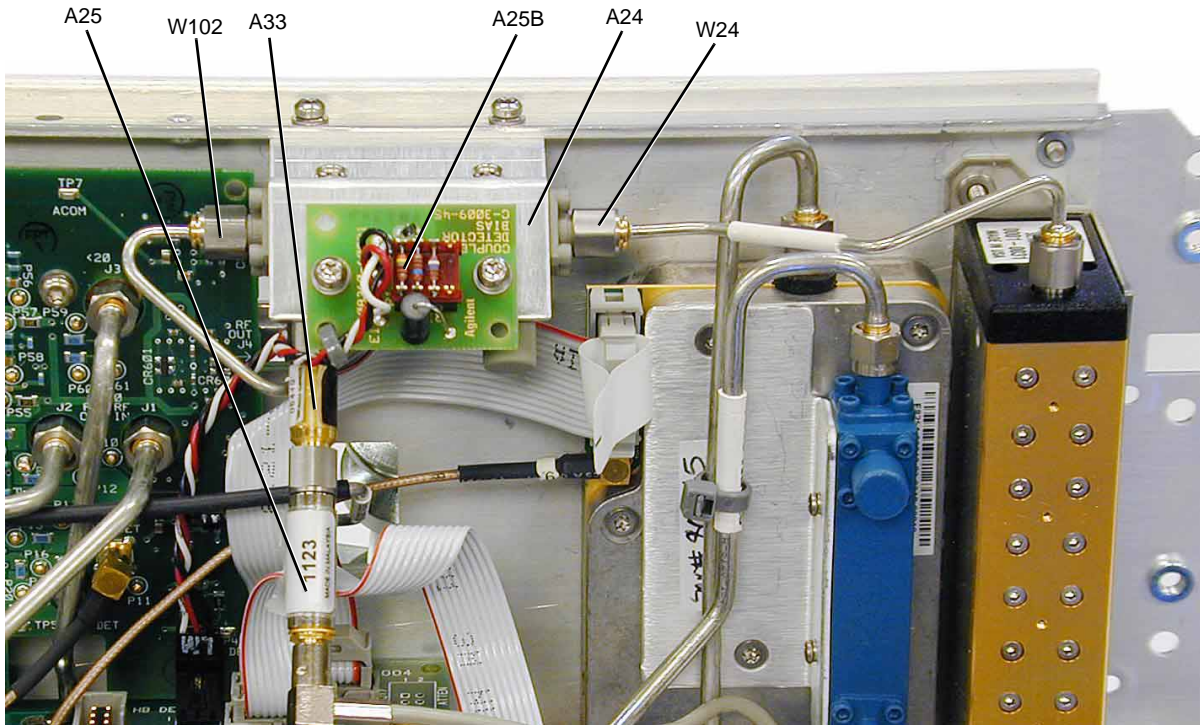
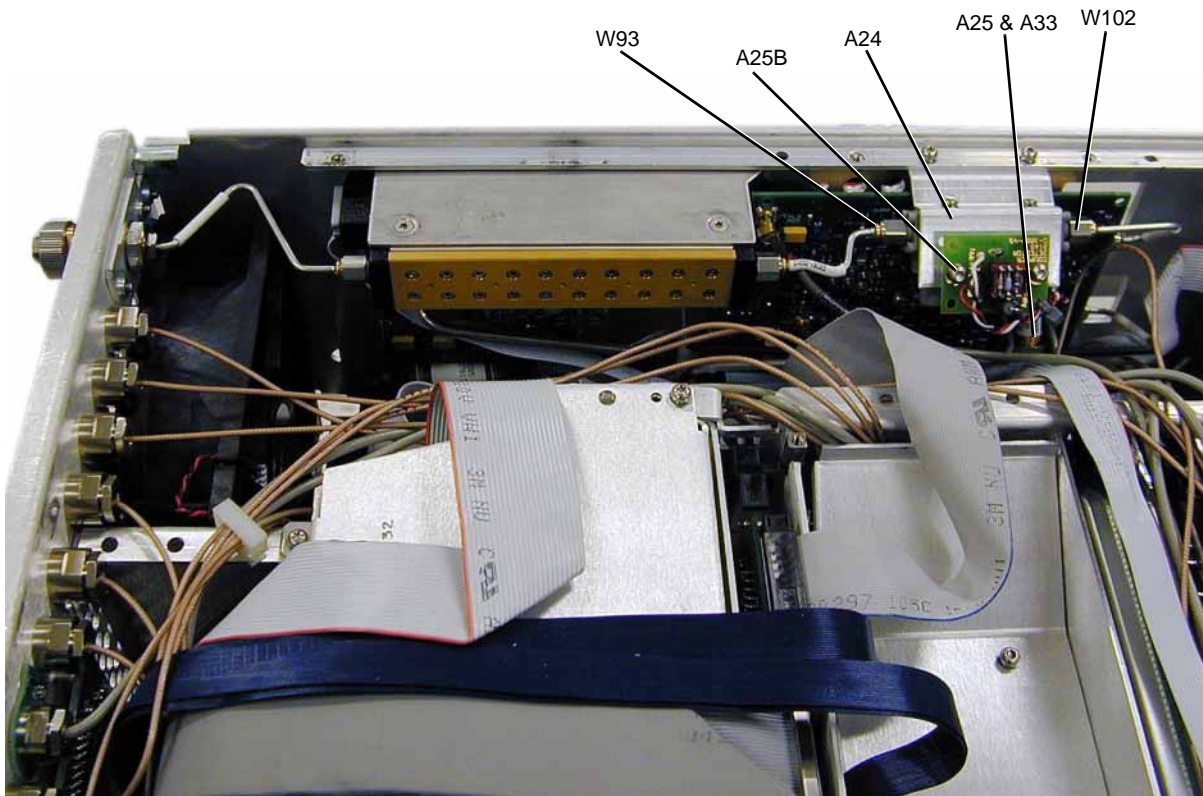

Figure 3-36 A24 50 GHz Highband Coupler (Options 532 & 544 – Option 1EM)



A24 67 GHz Highband Coupler (Options 550 and 567)

Tools Required

- T-10 driver
- 5/16" open-ended wrench

Removal Procedure

Refer to [Figure 3-37](#) and [Figure 3-38](#) for this procedure.

1. Disconnect the power cord.
2. Remove the covers from the signal generator. Refer to [“Outer Instrument Cover” on page 6](#) and [“Inner Instrument Cover” on page 8](#).
3. Position the signal generator with the A31 Motherboard facing away from you and the RF deck on top.
4. Using the 5/16" open-ended wrench, disconnect the A25 67 GHz Highband Detector from the A24 67 GHz Highband Coupler.

5. Using the 5/16" open-ended wrench, disconnect the following cables according to the signal generator you have.

Standard: Disconnect W112 and W89 RF cables from the A24 67 GHz Highband Coupler's input and output.

Option 1EM: Disconnect W112 and W81 RF cables from the A24 67 GHz Highband Coupler's input and output.

Option 1EM without Option 1E1: Disconnect W112 and W91 (not shown) RF cables from the A24 67 GHz Highband Coupler's input and output.

6. Using the T-10 driver, remove the two screws that connect the A25B Highband Detector Bias Board to the A24 67 GHz Highband Coupler.
7. Using the T-10 driver, remove the two screws that attach the coupler to the side panel.
8. Remove the A24 67 GHz Highband Coupler.

Replacement Procedure

1. Reverse the order of the removal procedure.
2. Torque all T-10 screws to 9 in-lbs.
3. Torque all RF connectors to 8 in-lbs.
4. Perform the post-repair adjustments and performance tests that pertain to this removal procedure.

Assembly Replacement
A24 67 GHz Highband Coupler (Options 550 and 567)

Figure 3-37 A24 67 GHz Highband Coupler (Options 550 & 567 – Standard)

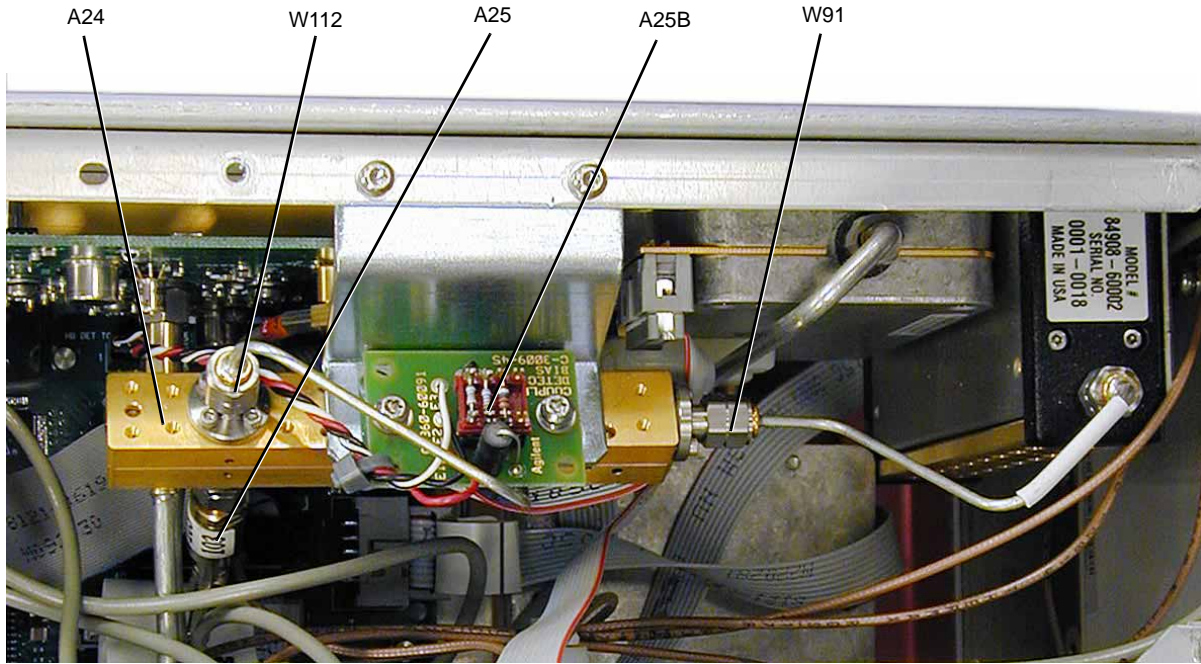
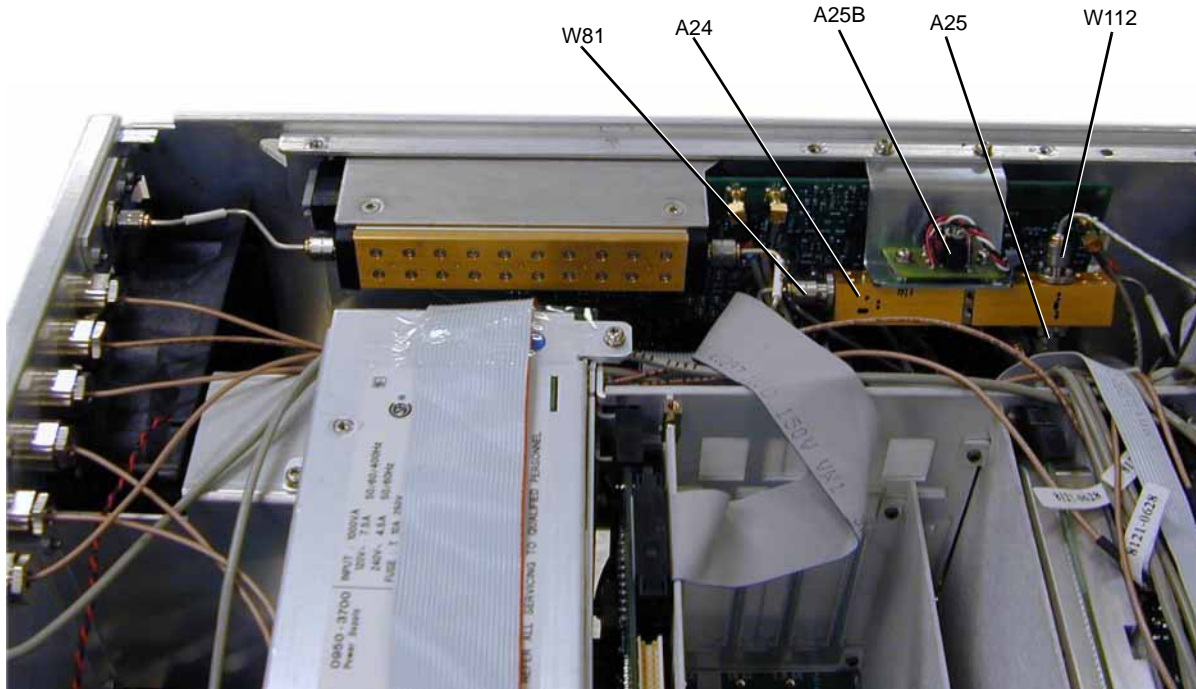

Figure 3-38 A24 67 GHz Highband Coupler (Options 550 & 567 and Option 1EM)



A25 20 GHz Highband Detector (Options 503, 509, 520, & 521)

Tools Required

- 5/16” open-ended wrench
- needle-nose pliers

Removal Procedure

Refer to **Figure 3-39** or **Figure 3-40** for this procedure.

1. Disconnect the power cord.
2. Remove the covers from the signal generator. Refer to “**Outer Instrument Cover**” on page 6 and “**Inner Instrument Cover**” on page 8.
3. Position the signal generator with the A31 Motherboard facing away from you and the RF deck on top.
4. Using the 5/16” open-ended wrench, disconnect the A25 20 GHz Highband Detector according to the signal generator you have.

E8257D & E8663D: Disconnect the A25 20 GHz Highband Detector from the A24 20 GHz Highband Coupler.

E8267D: Disconnect the A25 20 GHz Highband Detector from the A33 6dB PAD.
5. Using the needle-nose pliers, disconnect W15 (not shown) from the A25 20 GHz Highband Detector.
6. Remove the A25 20 GHz Highband Detector.

Replacement Procedure

1. Reverse the order of the removal procedure.
2. Perform the post-repair adjustments and performance tests that pertain to this removal procedure.

Assembly Replacement
A25 20 GHz Highband Detector (Options 503, 509, 520, & 521)

Figure 3-39 A25 20 GHz Highband Detector (Options 503, 509, & 520)

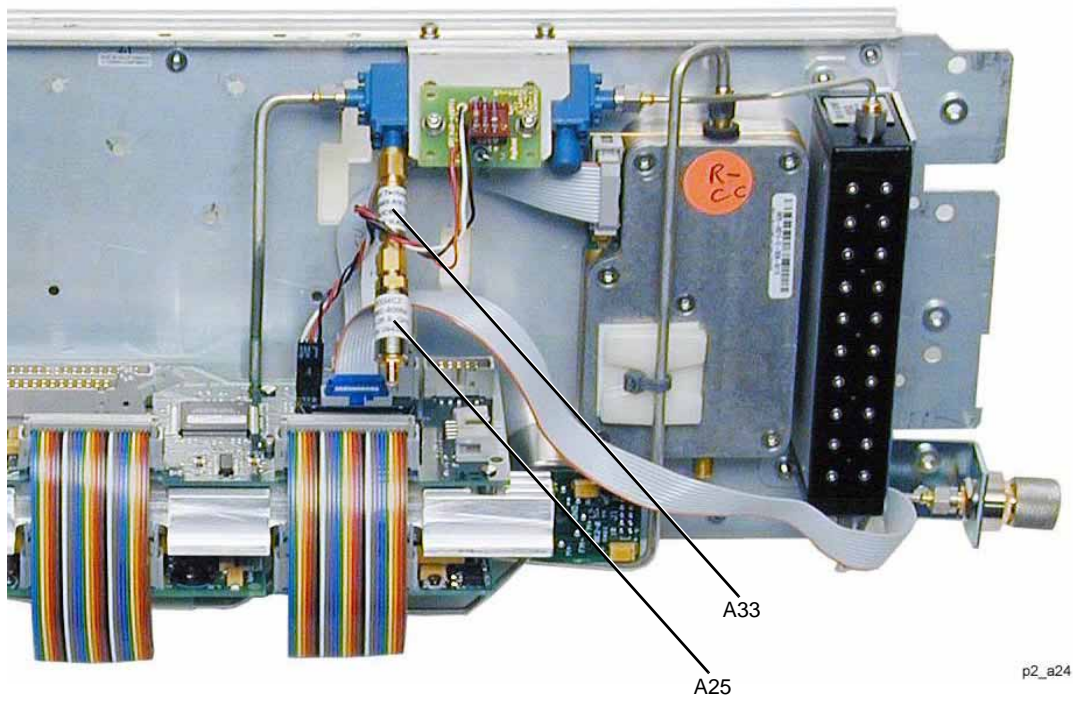

p2_a24

Assembly Replacement
A25 20 GHz Highband Detector (Options 503, 509, 520, & 521)

Figure 3-40 A25 20 GHz Highband Detector (Option 521)

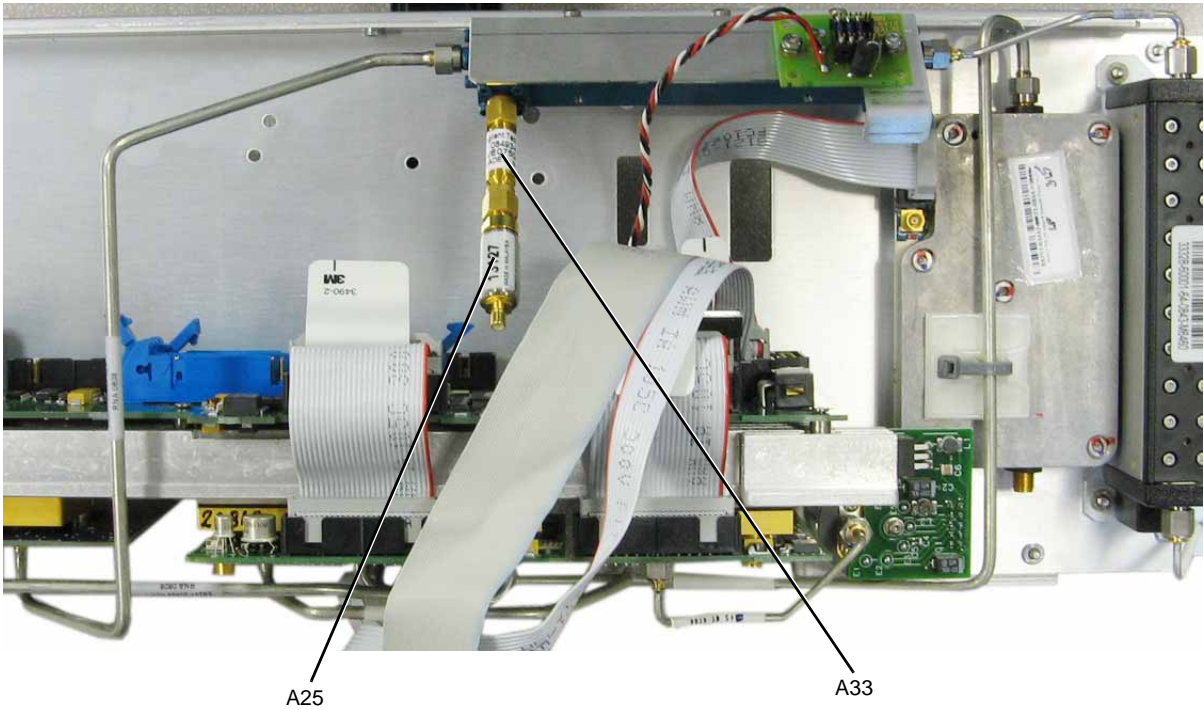

A25 40 GHz Highband Detector (Option 540)

Tools Required

- T-10 driver
- 5/16" open-ended wrench

Removal Procedure

Refer to **Figure 3-41** for this procedure.

1. Disconnect the power cord.
2. Remove the covers from the signal generator. Refer to “**Outer Instrument Cover**” on page 6 and “**Inner Instrument Cover**” on page 8.
3. Position the signal generator with the A31 Motherboard facing away from you and the RF deck on top.
4. Using the 5/16" open-ended wrench, disconnect the A25 40 GHz Highband Detector from the A24 40 GHz Highband Coupler.
5. Using the needle-nose pliers, disconnect W15 (not shown) from the A25 40 GHz Highband Detector.
6. Remove the A25 40 GHz Highband Detector.

Replacement Procedure

1. Reverse the order of the removal procedure.
2. Torque all T-10 screws to 9 in-lbs.
3. Torque all RF connectors to 8 in-lbs.
4. Perform the post-repair adjustments and performance tests that pertain to this removal procedure.

Assembly Replacement
A25 40 GHz Highband Detector (Option 540)

Figure 3-41 A25 40 GHz Highband Detector (Option 540)

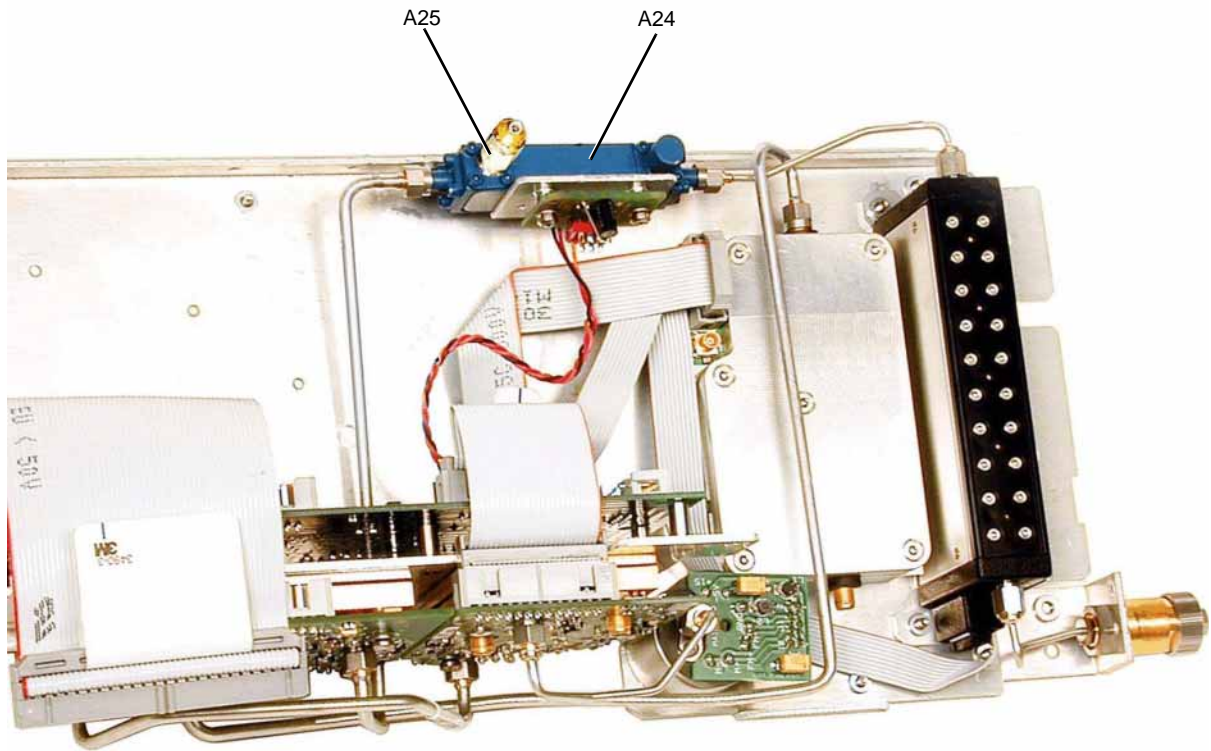

p-se974a

A25 50 GHz Highband Detector (Options 532 and 544)

Tools Required

- 5/16” open-ended wrench
- needle-nose pliers

Removal Procedure

Refer to **Figure 3-42** for this procedure.

1. Disconnect the power cord.
2. Remove the covers from the signal generator. Refer to “**Outer Instrument Cover**” on page 6 and “**Inner Instrument Cover**” on page 8.
3. Position the signal generator with the A31 Motherboard facing away from you and the RF deck on top.
4. Using the 5/16” open-ended wrench, disconnect the A25 50 GHz Highband Detector from the A33 6dB PAD.
5. Using the needle-nose pliers, disconnect W15 from the A25 50 GHz Highband Detector.
6. Remove the A25 50 GHz Highband Detector.

Replacement Procedure

1. Reverse the order of the removal procedure.
2. Perform the post-repair adjustments and performance tests that pertain to this removal procedure.

Assembly Replacement
A25 50 GHz Highband Detector (Options 532 and 544)

Figure 3-42 A25 50 GHz Highband Detector (Options 532 and 544)

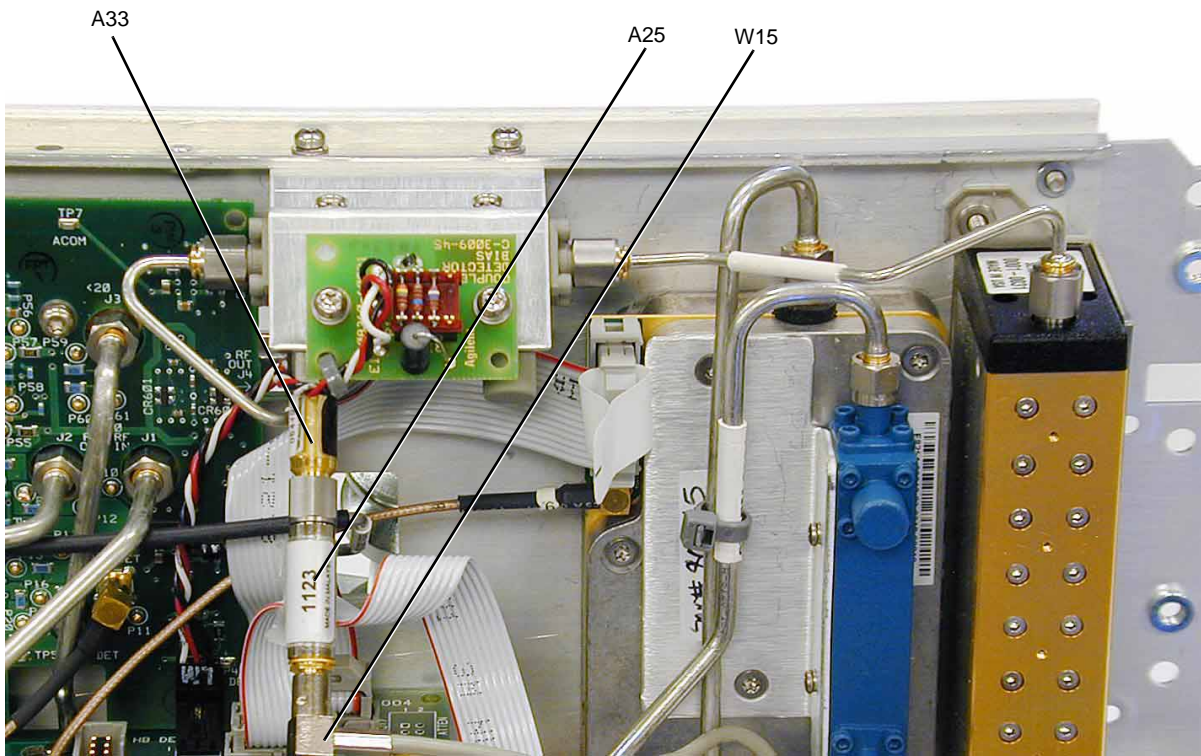

A25 67 GHz Highband Detector (Options 550 and 567)

Tools Required

- T-10 driver
- 5/16" open-ended wrench

Removal Procedure

Refer to **Figure 3-43** for this procedure.

1. Disconnect the power cord.
2. Remove the covers from the signal generator. Refer to “**Outer Instrument Cover**” on page 6 and “**Inner Instrument Cover**” on page 8.
3. Position the signal generator with the A31 Motherboard facing away from you and the RF deck on top.
4. Using the 5/16" open-ended wrench, disconnect the A25 67 GHz Highband Detector from the A24 67 GHz Highband Coupler.
5. Using the needle-nose pliers, disconnect W15 (not shown) from the A25 67 GHz Highband Detector.
6. Remove the A25 67 GHz Highband Detector.

Replacement Procedure

1. Reverse the order of the removal procedure.
2. Torque all T-10 screws to 9 in-lbs.
3. Torque all RF connectors to 8 in-lbs.
4. Perform the post-repair adjustments and performance tests that pertain to this removal procedure.

Assembly Replacement
A25 67 GHz Highband Detector (Options 550 and 567)

Figure 3-43 A25 67 GHz Highband Detector (Options 550 and 567)

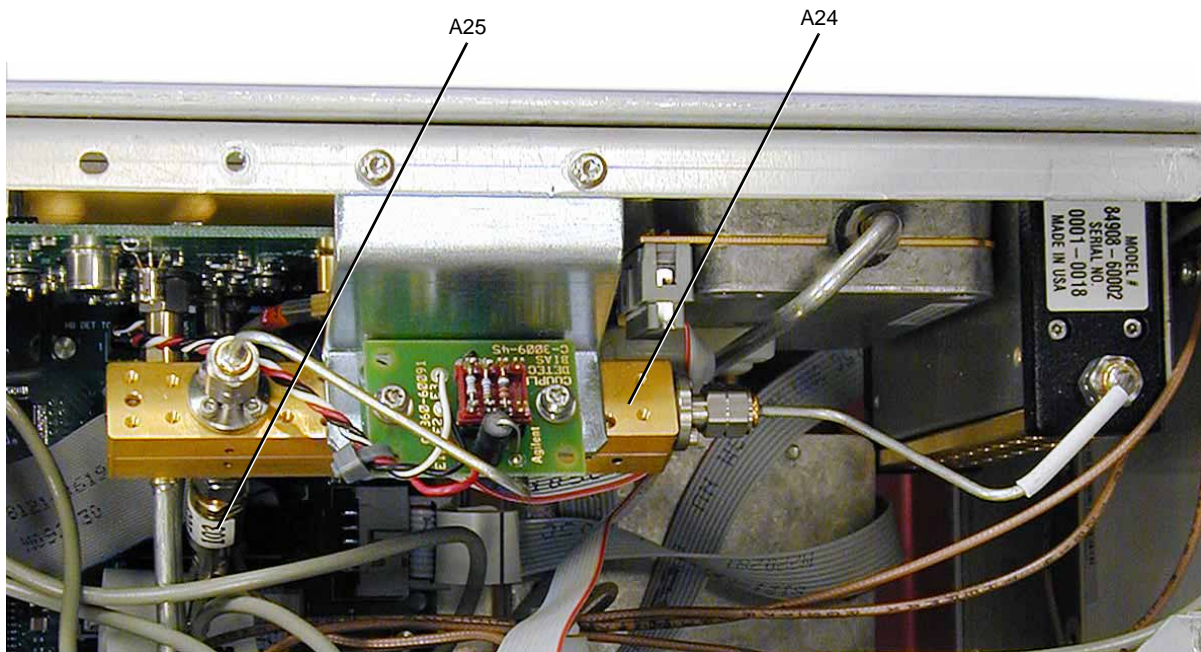

A25B Highband Detector Bias Board

Tools Required

- T-10 driver

Removal Procedure

Refer to **Figure 3-44** for this procedure.

- 1. Disconnect the power cord.**
- 2. Remove the covers from the signal generator. Refer to “Outer Instrument Cover” on page 6 and “Inner Instrument Cover” on page 8.**
- 3. Position the signal generator with the A31 Motherboard facing away from you and the RF deck on top.**
- 4. Disconnect the A25BW1 bias board power cable from the A26 MID J12.**
- 5. Using the T-10 driver, remove the two screws (1) that attach the A25B Highband Detector Bias Board to the A24 Highband Coupler.**
- 6. Remove the A25B Highband Detector Bias Board.**

Replacement Procedure

- Reverse the order of the removal procedure.
- Torque all T-10 screws to 9 in-lbs.
- Perform the post-repair adjustments and performance tests that pertain to this removal procedure.

Assembly Replacement
A25B Highband Detector Bias Board

Figure 3-44 A25B Highband Detector Bias Board

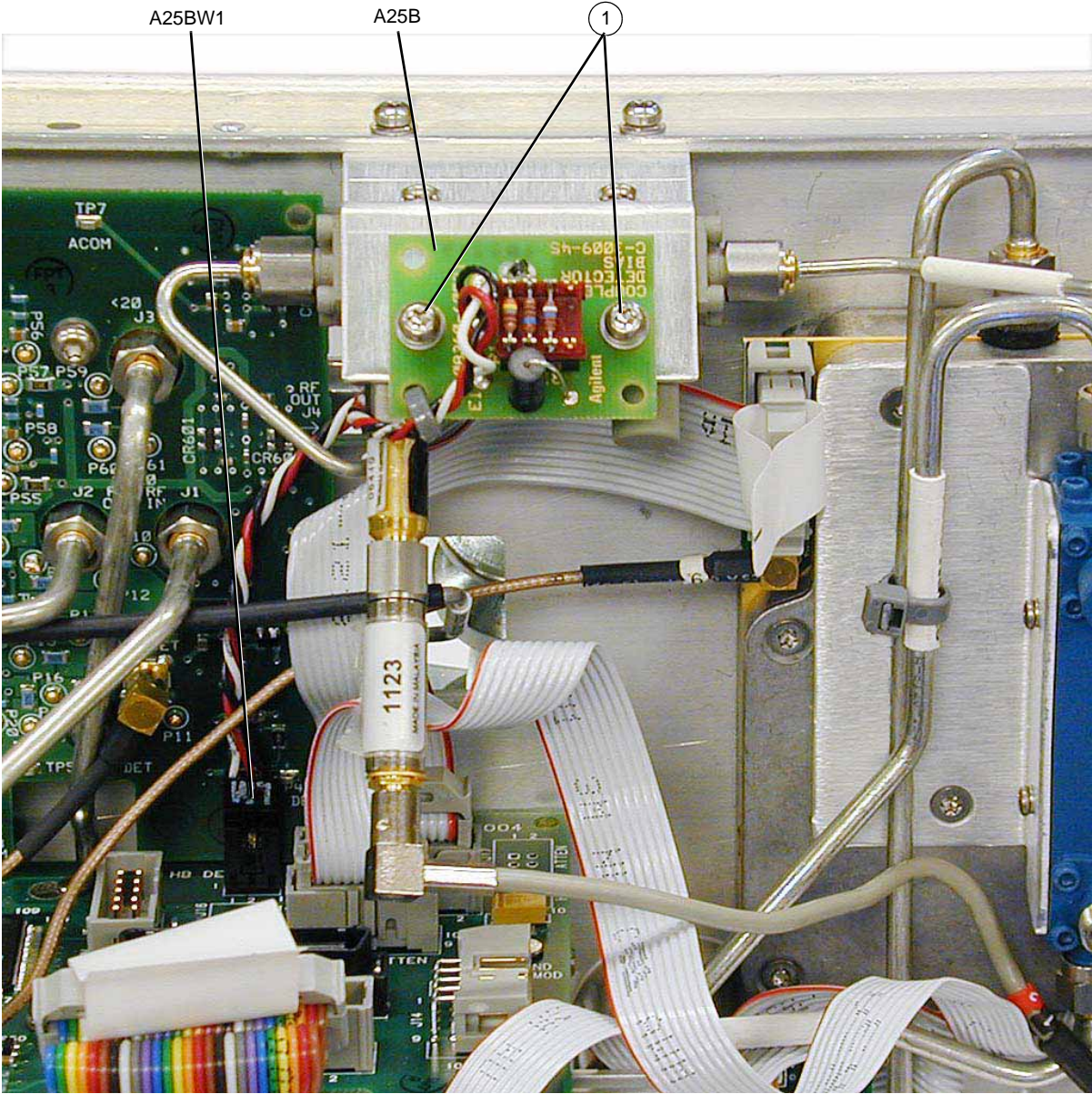

A26 MID (Microcircuit Interface Deck)

Tools Required

- T-10 driver

Removal Procedure

Refer to **Figure 3-45** and **Figure 3-46** for this procedure.

1. Disconnect the power cord.
2. Remove the covers from the signal generator. Refer to “**Outer Instrument Cover**” on page 6 and “**Inner Instrument Cover**” on page 8.
3. Position the signal generator with the A31 Motherboard facing you and the RF deck on top.
4. If you have an Option 532, 540, or 544 signal generator, disconnect the W29 ribbon cable from A26J33.
5. Disconnect the following ribbon cables:
 - W69 from A26J14
 - W28 from A26J15
 - W19 from A26J30
 - W36 from A26J13
 - W33 from A26J32
 - W34 from A26J31
 - W35 from A26J10
 - W20 from A26J20
 - W113 from A26J34 (E8257D & E8663D only)
 - W70 from A26J34 (E8267D only)
 - W99 from the A26J35 (Option 532 and 544 only)
 - W116 from the A26J36 (Option 532 and 544 only)
6. Disconnect the A25BW1 power cable from A26J12.
7. Using the T-10 driver, loosen the screw (1) that secures the A26 MID to the RF deck.
8. Slide the A26 MID towards the front panel until the locking standoffs are free.
9. Remove the A26 MID from the RF bracket.

Replacement Procedure

1. Reverse the order of the removal procedure.
2. Torque all T-10 screws to 9 in-lbs.
3. Perform the post-repair adjustments and performance tests that pertain to this removal procedure.

Figure 3-45 A26 MID (E8257D & E8663D)

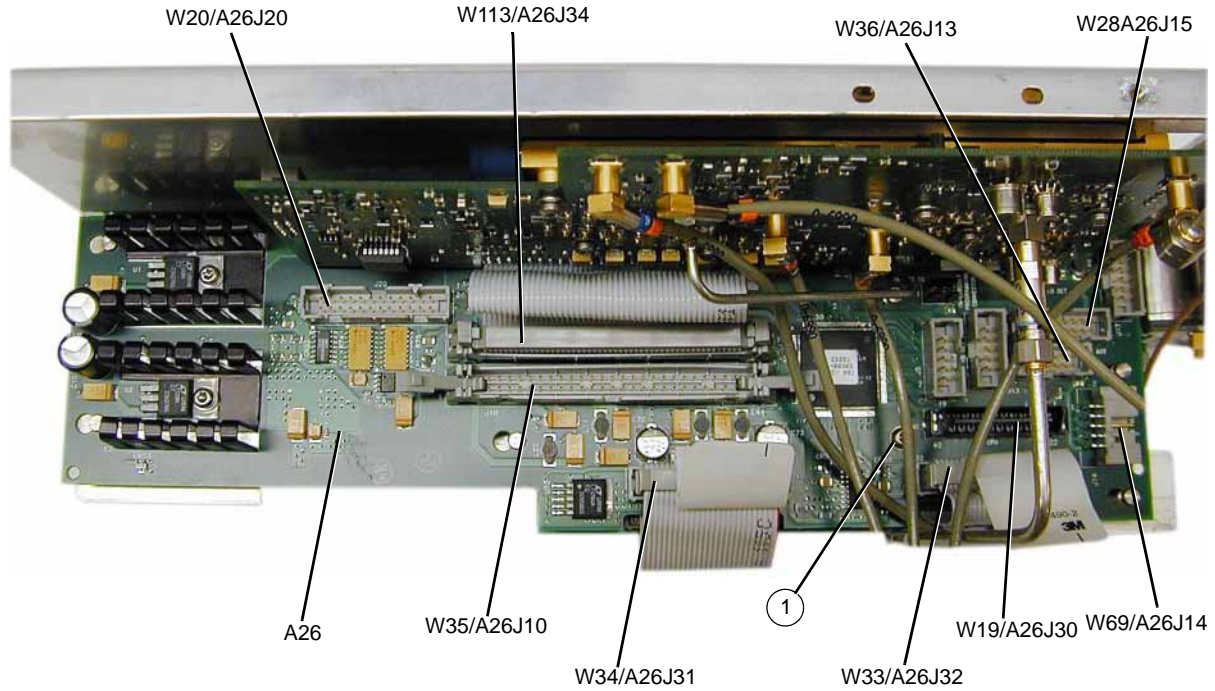
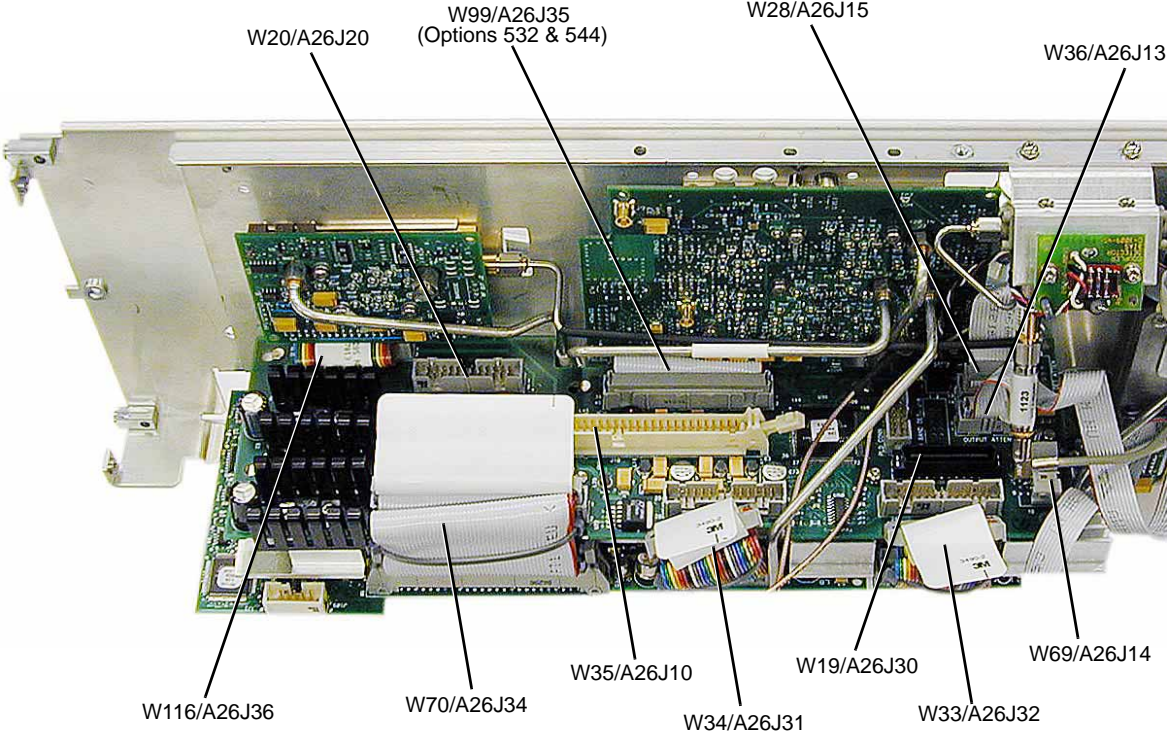

Figure 3-46 A26 MID (E8267D)



A27 40 GHz Doubler (Option 540)

Tools Required

- T-10 driver
- 5/16" open-ended wrench

Removal Procedure

Refer to **Figure 3-47** for this procedure.

1. Disconnect the power cord.
2. Remove the covers from the signal generator. Refer to **“Outer Instrument Cover” on page 6** and **“Inner Instrument Cover” on page 8**.
3. Position the signal generator with the A31 Motherboard facing away from you and the RF deck on top.
4. Using the 5/16" open-ended wrench, disconnect the following RF cables:
 - Standard – W30 from A27 40 GHz Doubler or Option 1EM – W83 from A27 40 GHz Doubler
 - W31 from A27J3
 - W32 from A27J1
5. Using the T-10 driver, remove the two screws that attach the A27 40 GHz Doubler to the side panel.
6. Disconnect the W29 ribbon cable from the A27 40 GHz Doubler's board.
7. Remove the A27 40 GHz Doubler from the RF deck.

Replacement Procedure

1. Reverse the order of the removal procedure.
2. Torque all T-10 screws to 9 in-lbs.
3. Torque all RF connectors to 8 in-lbs.
4. Perform the post-repair adjustments and performance tests that pertain to this removal procedure.

Assembly Replacement
A27 40 GHz Doubler (Option 540)

Figure 3-47 A27 40 GHz Doubler (Option 540)

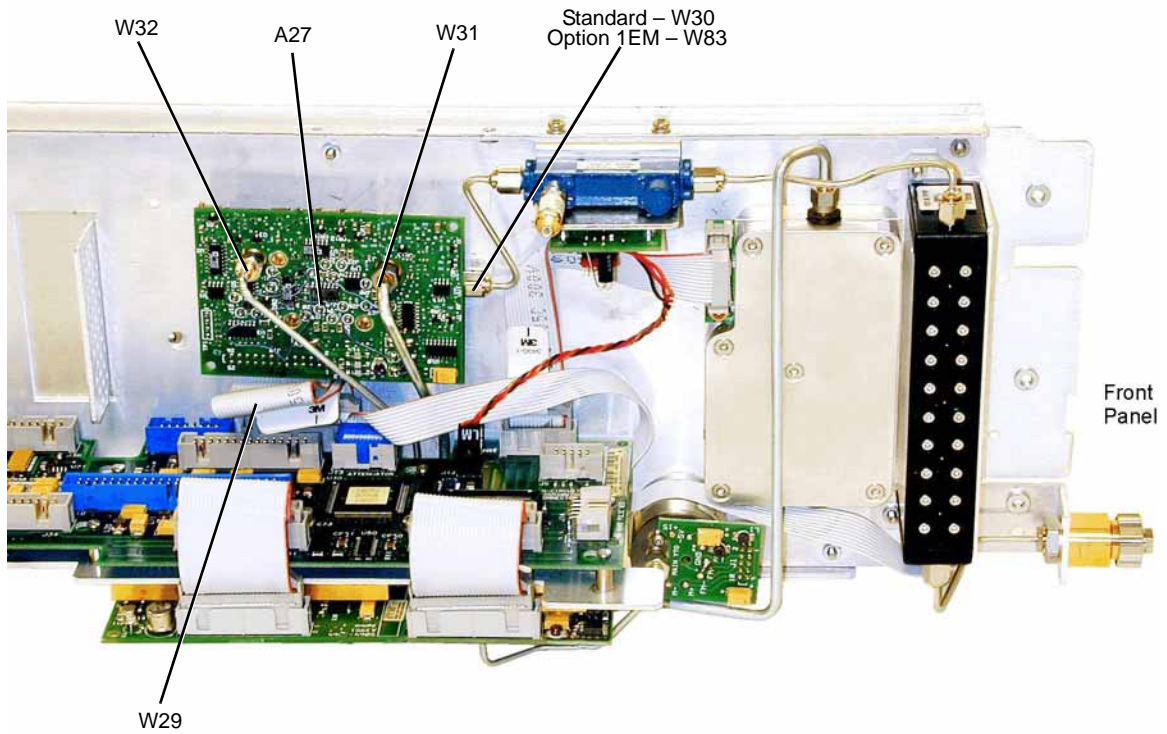

p-se967a

A27 40 GHz Doubler (Options 532 and 544 only)

Tools Required

- T-10 driver
- 5/16" open-ended wrench

Removal Procedure

Refer to **Figure 3-48** for this procedure.

1. Disconnect the power cord.
2. Remove the covers from the signal generator. Refer to **“Outer Instrument Cover” on page 6** and **“Inner Instrument Cover” on page 8**.
3. Position the signal generator with the A31 Motherboard facing away from you and the RF deck on top.
4. Using the 5/16" open-ended wrench, disconnect the following RF cables:
 - W100 from A27J2
 - W104 from A27J1
5. Using the T-10 driver, remove the two screws that attach the A27 40 GHz Doubler to the side panel.
6. Disconnect the W116 ribbon cable from A27J10.
7. Remove the A27 40 GHz Doubler from the RF deck.

Replacement Procedure

1. Reverse the order of the removal procedure.
2. Torque all T-10 screws to 9 in-lbs.
3. Torque all RF connectors to 8 in-lbs.
4. Perform the post-repair adjustments and performance tests that pertain to this removal procedure.

Assembly Replacement
A27 40 GHz Doubler (Options 532 and 544 only)

Figure 3-48 A27 40 GHz Doubler (Options 532 and 544)

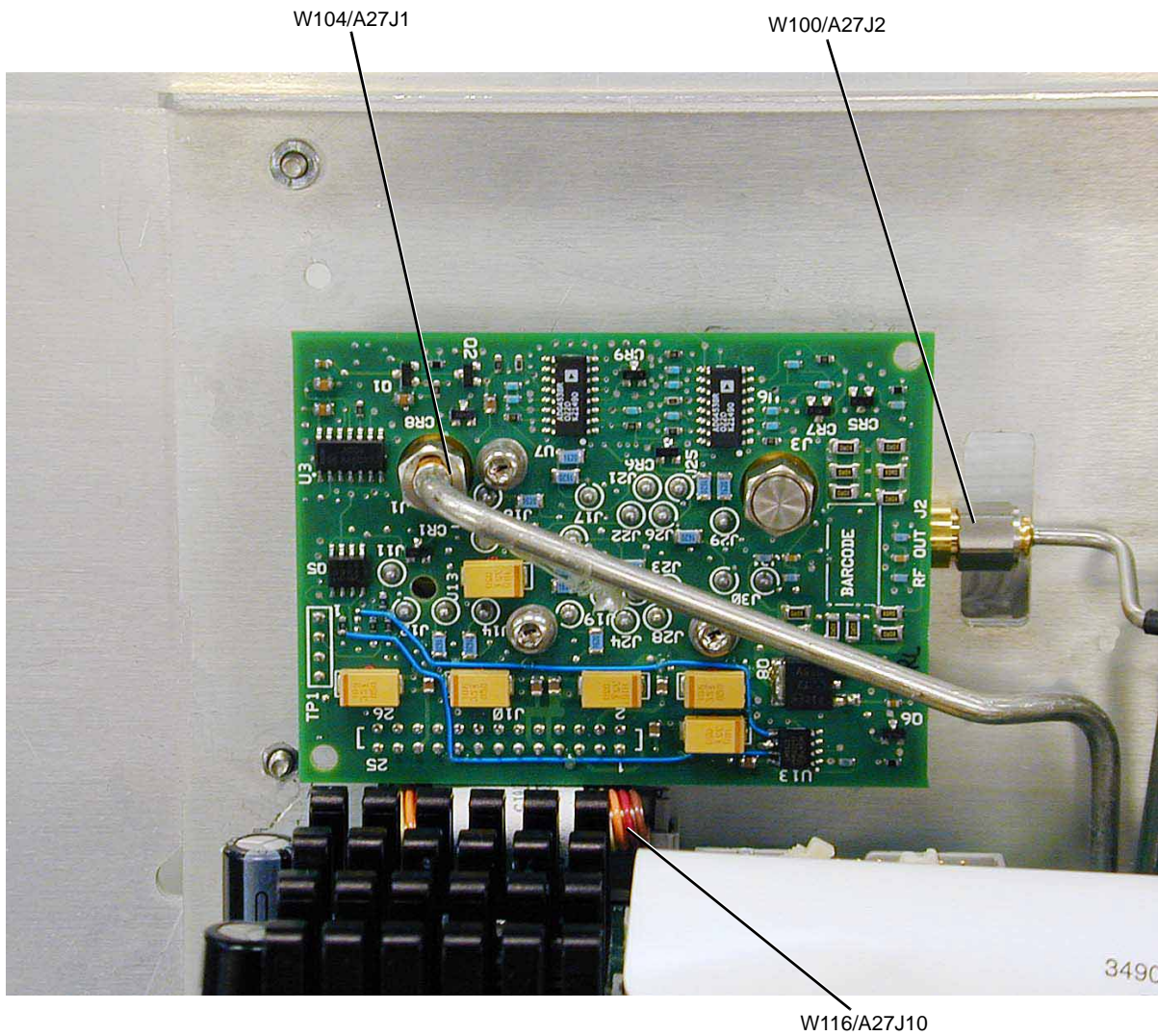

A28 YIG Oscillator

Tools Required

- T-10 driver
- 5/16" open-ended wrench

Removal Procedure

Refer to **Figure 3-49** for this procedure.

1. Disconnect the power cord.
2. Remove the covers from the signal generator. Refer to “**Outer Instrument Cover**” on page 6 and “**Inner Instrument Cover**” on page 8.
3. Position the signal generator with the A31 Motherboard facing you and the RF deck on top.
4. Using the 5/16" open-ended wrench, disconnect the following RF cable according to the signal generator you have:
E8257D & E8663D: Disconnect the W41 RF cable from the A28J1.
E8267D: Disconnect the W101 RMF cable from the A28J1.
5. Disconnect the W12 ribbon cable from the A28 YIG Oscillator's driver board.
6. Using the T-10 driver, remove the two screws (1) that attach the A28 YIG Oscillator to the side panel.
7. Using the 5/16" open-ended wrench, disconnect the W27 RF cable from the A30 Modulation Filter with High Power.
8. Remove the A28 YIG Oscillator.

Replacement Procedure

1. Reverse the order of the removal procedure.
2. Torque all T-10 screws to 9 in-lbs.
3. Torque all RF connectors to 8 in-lbs.
4. Perform the post-repair adjustments and performance tests that pertain to this removal procedure.

Figure 3-49 A28 YIG Oscillator

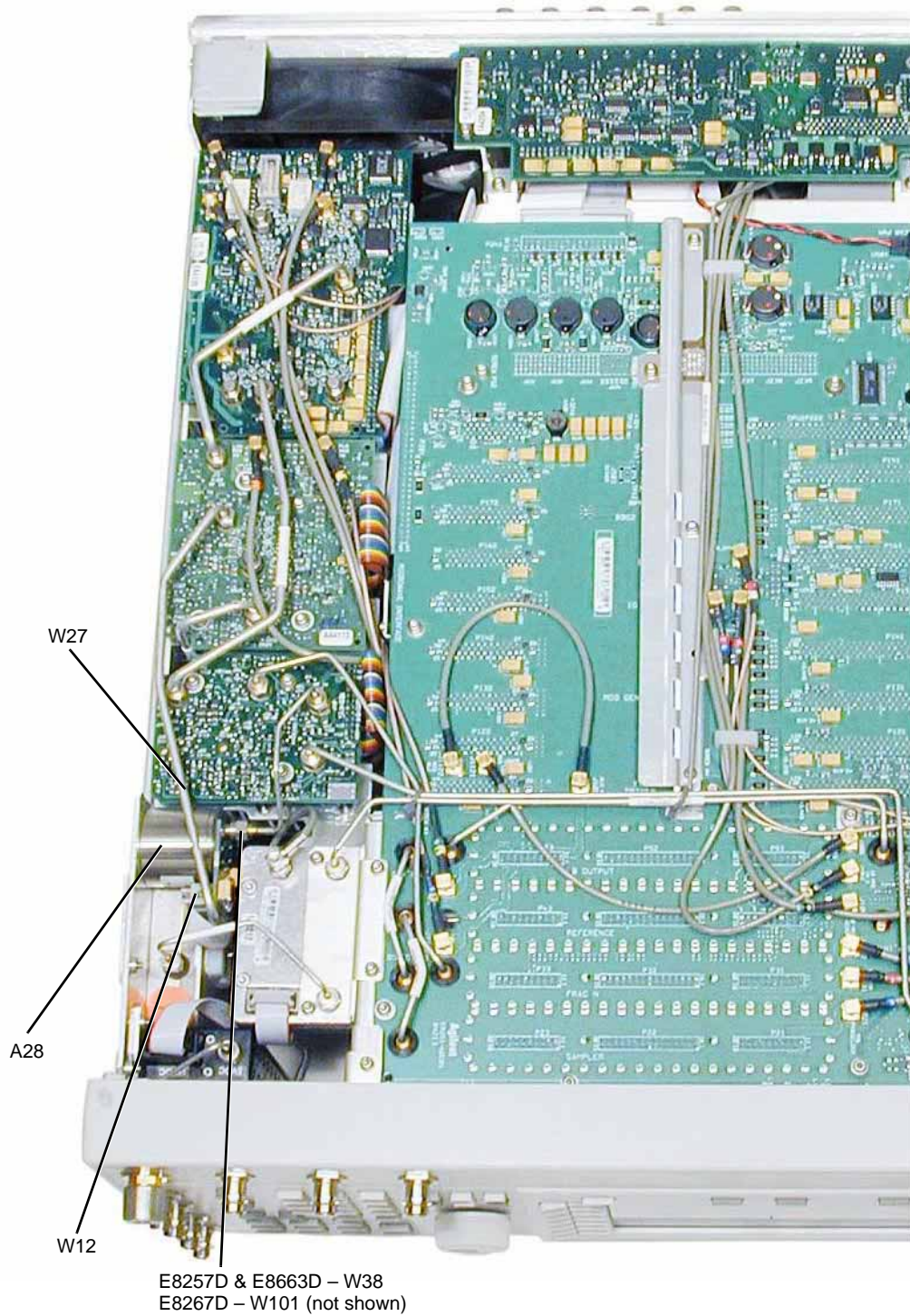

A29 20 GHz Doubler

Tools Required

- T-10 driver
- 5/16" open-ended wrench

Removal Procedure

Refer to **Figure 3-50** for this procedure.

1. Disconnect the power cord.
2. Remove the covers from the signal generator. Refer to “**Outer Instrument Cover**” on page 6 and “**Inner Instrument Cover**” on page 8.
3. Position the signal generator with the A31 Motherboard facing you and the RF deck on top.
4. Using the 5/16" open-ended wrench, disconnect the following RF cables:
 - W39 from A29J4
 - W40 from A29J3
5. Using the 5/16" open-ended wrench, disconnect the following RF cable according to the signal generator you have.

E8257D & E8663D: Disconnect the W41 RF cable from A29J2 and the W38 RF cable from A29J1.

E8267D: Disconnect the W77 RF cable from A29J2 and the W115 RF cable from A29J1.
6. Using the T-10 driver, remove the two screws (1) that attach the A29 20 GHz Doubler to the RF deck.
7. Disconnect the W33 ribbon cable from A29J10.
8. Remove the A29 20 GHz Doubler from the RF deck.

Replacement Procedure

1. Reverse the order of the removal procedure.
2. Torque all T-10 screws to 9 in-lbs.
3. Torque all RF connectors to 8 in-lbs.
4. Perform the post-repair adjustments and performance tests that pertain to this removal procedure.

A30 Modulation Filter (Standard and Option 1EA/1EU)

Tools Required

- T-10 driver
- 5/16" open-ended wrench

Removal Procedure

Refer to **Figure 3-51** for this procedure.

1. Disconnect the power cord.
2. Remove the covers from the signal generator. Refer to **“Outer Instrument Cover” on page 6** and **“Inner Instrument Cover” on page 8**.
3. Position the signal generator with the A31 Motherboard facing away from you and the RF deck on top.
4. Disconnect the following flexible cables:
 - W17 from A30J7
 - W108 from A30J6 (Options (550 and 567 only)
5. Using the 5/16" open-ended wrench, disconnect the following RF cable according to the signal generator you have.
E8257D/E8663D: Disconnect the W41 RF cable from A30J1.
E8267D: Disconnect the W98 RF cable from A30J1.
6. Disconnect the W34 ribbon cable from the A30 Modulator Filter.
7. Using the 5/16" open-ended wrench, disconnect the following RF cable according to the signal generator you have.
Option 520, & 521 Standard: Disconnect the W74 RF cable from A30J2.
Option 540 Standard: Disconnect the W31 RF cable from A30J2.
Option 550/567 Standard: Disconnect the W107 RF cable from A30J2.
Option 1EM: Disconnect the W71 RF cable from A30J2.
8. Using the 5/16" open-ended wrench, disconnect the following RF cables:
 - W27 from A30J3
 - W32 from A30J4
 - W106 from A30J4 (Option 550/567 only)
9. Using the T-10 driver, remove the three screws (1) that attach the A30 Modulator Filter to the RF bracket.
10. Remove the A30 Modulator Filter from the RF deck.

Replacement Procedure

- 1. Reverse the order of the removal procedure.**
- 2. Torque all T-10 screws to 9 in-lbs.**
- 3. Torque all RF connectors to 8 in-lbs.**
- 4. Perform the post-repair adjustments and performance tests that pertain to this removal procedure.**

Assembly Replacement
A30 Modulation Filter (Standard and Option 1EA/1EU)

Figure 3-51 A30 Modulator Filter

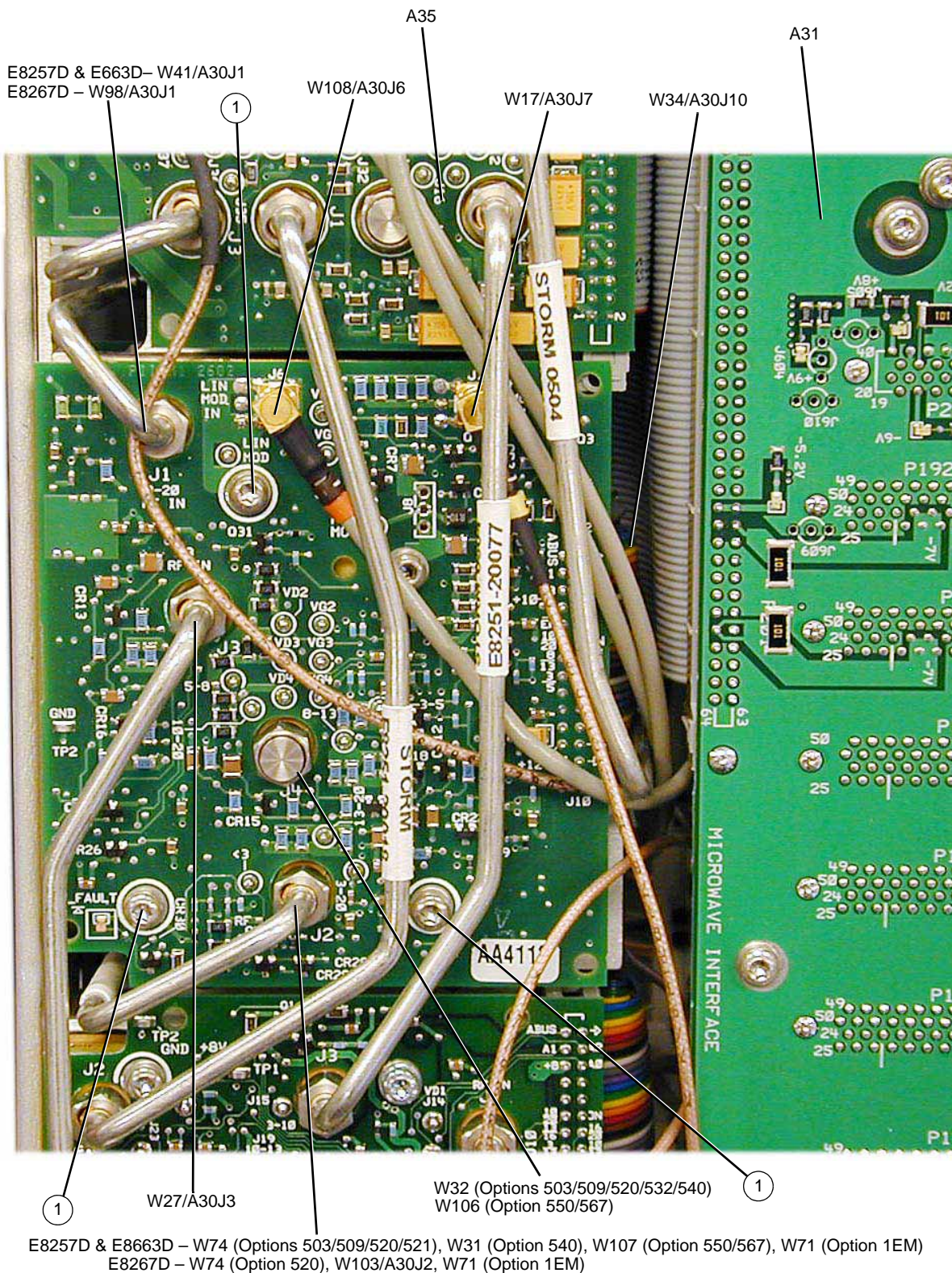

A31 Motherboard (E8257D & E8663D)

Tools Required

- T-10 driver
- 5/16" open-ended wrench
- needle-nose pliers

Removal Procedure

Refer to **Figure 3-52** for this procedure.

1. Disconnect the power cord.
2. Remove the covers from the signal generator. Refer to **"Outer Instrument Cover" on page 6** and **"Inner Instrument Cover" on page 8**.
3. Position the signal generator with the A31 Motherboard facing you and the RF deck on top.
4. Remove the front panel. Refer to **"Front Panel" on page 10**.
5. Remove the assemblies that are inserted into the A31 Motherboard. Refer to **"A5 Sampler, A6 Frac-N, A7 Reference (Standard and Option UNR/UNX/UNY), A8 Output, A45 Frac-N and A46 Offset" on page 27**, **"A9 YIG Driver" on page 29**, **"A10 ALC" on page 31**, **"A11 Pulse/Analog Modulation Generator" on page 33**, **"A14 Baseband Generator (E8267D Only)" on page 41**, **"A18 CPU" on page 45**, and **"A13 I/Q MUX (E8267D Standard or with Option 015) (Serial Prefixes <US4722/MY4722)" on page 37**.
6. Using the 5/16" open-ended wrench, disconnect the following RF cables:
 - W40 from A29J3
 - W39 from A29J4
 - W37 from the A23 Lowband Coupler/Detector
 - W137 from W121
7. Using the needle-nose pliers, disconnect the following flexible cables:
 - W21 from A31J1043
 - W10 from A31J1031
 - W11 from A31J1021
 - W54 from A31J1032
 - W47 from A31J1041
 - W22 from A31J1042

- 8.** Using needle-nose pliers, disconnect W138 from the A31 Motherboard.
- 9.** Disconnect the W23 ribbon cable from the A21 Rear Panel Interface while removing the A31 Motherboard from the chassis.
- 10.** Disconnect the W35 ribbon cable from the A26 MID J10.
- 11.** Disconnect the W135 cable from A31P242 (Option 521 only).
- 12.** Using the T-10 driver, remove the 15 screws (1) that hold the A31 Motherboard to the chassis.

Replacement Procedure

- 1.** Reverse the order of the removal procedure.
- 2.** Send command: `DIAG:FILE:BACK`, this copies data to the Motherboard.
- 3.** Torque all T-10 screws to 9 in-lbs.
- 4.** Torque all RF connectors to 8 in-lbs.
- 5.** Perform the post-repair adjustments and performance tests that pertain to this removal procedure.

Assembly Replacement
A31 Motherboard (E8257D & E8663D)

Figure 3-52 A31 Motherboard (E8257D & E8663D)

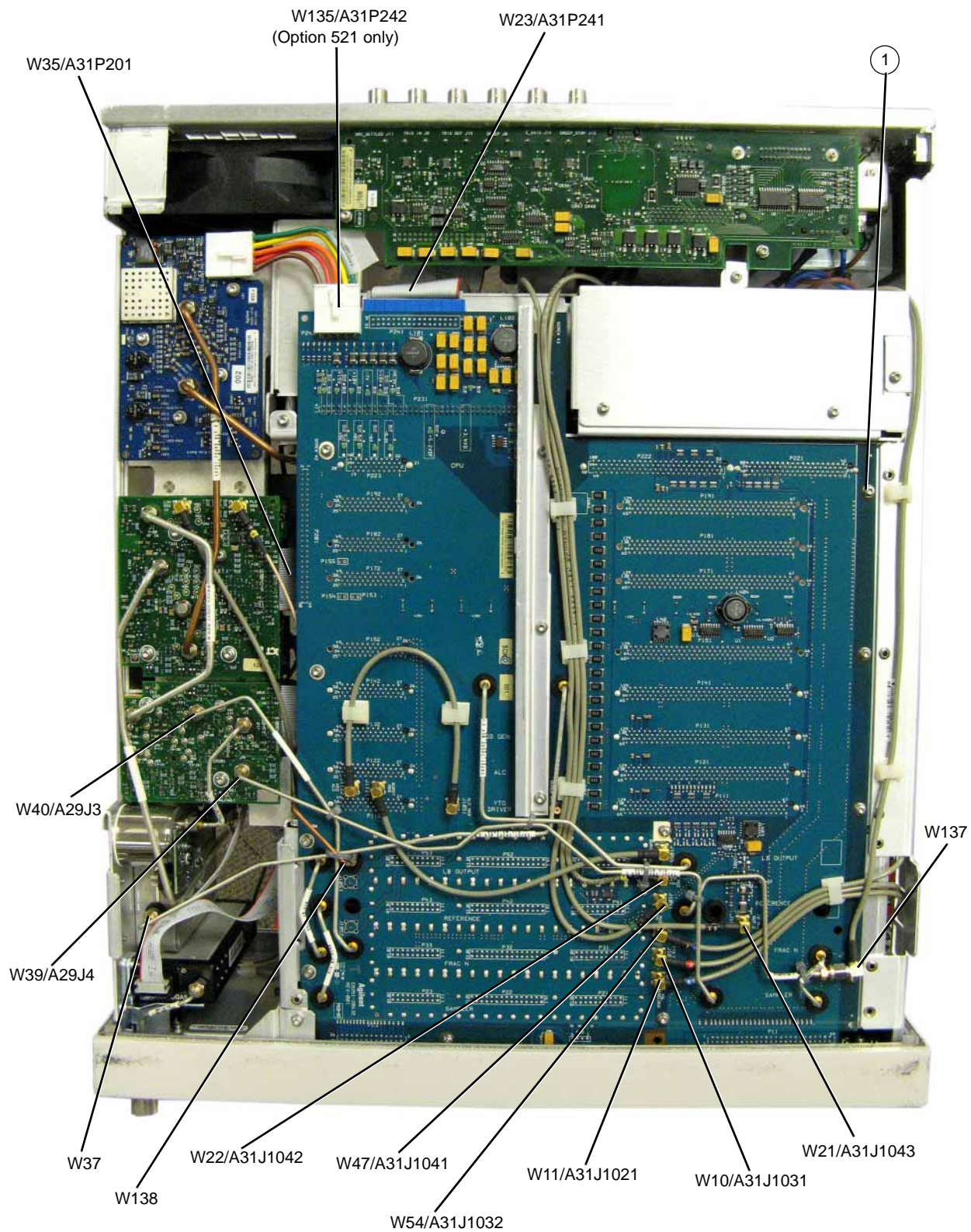

A31 Motherboard (E8267D)

Tools Required

- T-10 driver
- 5/16" open-ended wrench
- needle-nose pliers

Removal Procedure

Refer to **Figure 3-53** for this procedure.

1. Disconnect the power cord.
2. Remove the covers from the signal generator. Refer to **“Outer Instrument Cover” on page 6** and **“Inner Instrument Cover” on page 8**.
3. Position the signal generator with the A31 Motherboard facing you and the RF deck on top.
4. Remove the front panel. Refer to **“Front Panel” on page 10**.
5. Remove the assemblies that are inserted into the A31 Motherboard. Refer to **“A5 Sampler, A6 Frac-N, A7 Reference (Standard and Option UNR/UNX/UNY), A8 Output, A45 Frac-N and A46 Offset” on page 27**, **“A9 YIG Driver” on page 29**, **“A10 ALC” on page 32**, **“A11 Pulse/Analog Modulation Generator” on page 34**, **“A14 Baseband Generator (E8267D Only)” on page 41**, **“A18 CPU” on page 46**, and **“A13 I/Q MUX (E8267D Standard or with Option 015) (Serial Prefixes <US4722/MY4722)” on page 37**.
6. Using the 5/16" open-ended wrench, disconnect the following RF cables:
 - W67 from Rear Panel (.25–3.2 GHz COH CARRIER)
 - W39 from A29 20 GHz Doubler J4
 - W76 from A12 Pulse Modulator Board
7. Using the needle-nose pliers, disconnect the following flexible cables:
 - W21 from A31J1043
 - W10 from A31J1031
 - W54 from A31J1032
 - W47 from A31J1041
 - W22 from A31J1042
 - W60 from A31J1052
 - W61 from A31J1053

- W51 from A31J500
 - W52 from A31J501
 - W53 from A31J502
8. Using the needle-nose pliers, disconnect the W68 wire cable from A31J250
 9. Disconnect the W23 ribbon cable from the A21 Rear Panel Interface while removing the A31 Motherboard from the chassis.
 10. Disconnect the W35 ribbon cable (not shown in [Figure 3-53](#)) from the A26 MID J10.
 11. Using the T-10 driver, remove the 15 screws (1) that hold the A31 Motherboard to the chassis.

Replacement Procedure

1. Reverse the order of the removal procedure.
2. Send command "DIAG:FILE:BACK", this copies data to the Motherboard.
3. Torque all T-10 screws to 9 in-lbs.
4. Torque all RF connectors to 8 in-lbs.
5. Perform the post-repair adjustments and performance tests that pertain to this removal procedure.

Assembly Replacement
A31 Motherboard (E8267D)

Figure 3-53 A31 Motherboard (E8267D)

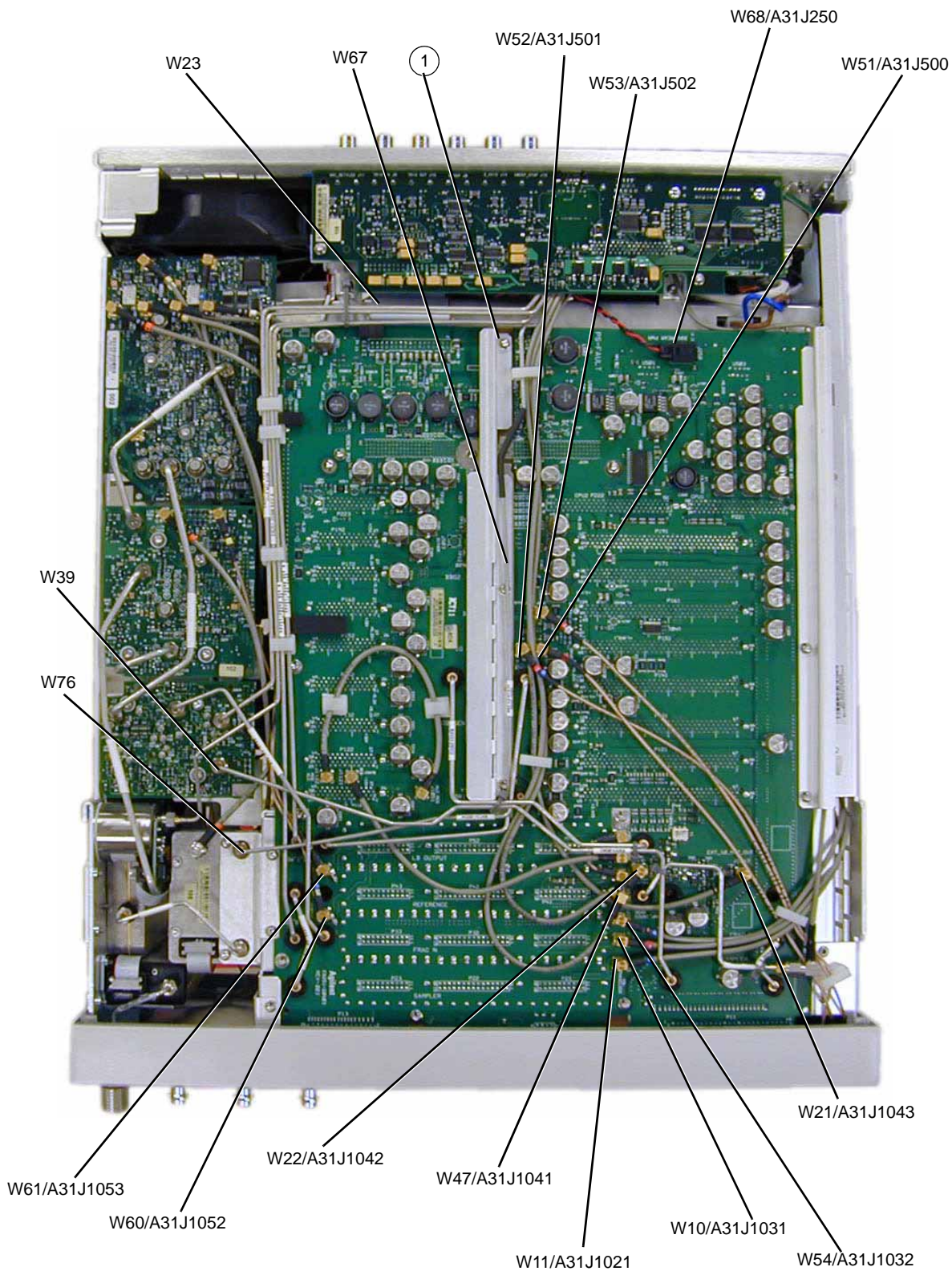

A32 10 MHz Crystal Oscillator

Tools Required

- T-10 driver
- needle-nose pliers

Removal Procedure

Refer to **Figure 3-54** for this procedure.

1. Disconnect the power cord.
2. Remove the covers from the signal generator. Refer to “**Outer Instrument Cover**” on page 6 and “**Inner Instrument Cover**” on page 8.
3. Position the signal generator with the Rear Panel facing you.
4. Using the needle-nose pliers, disconnect the W47 flexible cable (A31 Motherboard J1041) from A32J2.
5. Using the needle-nose pliers, disconnect the W48 flexible cable (10 MHz EFC) from A32J1 (Option UNR/UNX only).
6. Disconnect the A32W1 bias cable from the A21 Rear Panel Interface P2.
7. Using the T-10 driver, remove the three screws (1) that attach the A32 10 MHz Crystal Oscillator to the rear panel.
8. Remove the A32 10 MHz Crystal Oscillator.

Replacement Procedure

1. Reverse the order of the removal procedure.
2. Torque all T-10 screws to 9 in-lbs.
3. Perform the post-repair adjustments and performance tests that pertain to this removal procedure.

Figure 3-54 A32 Crystal Oscillator

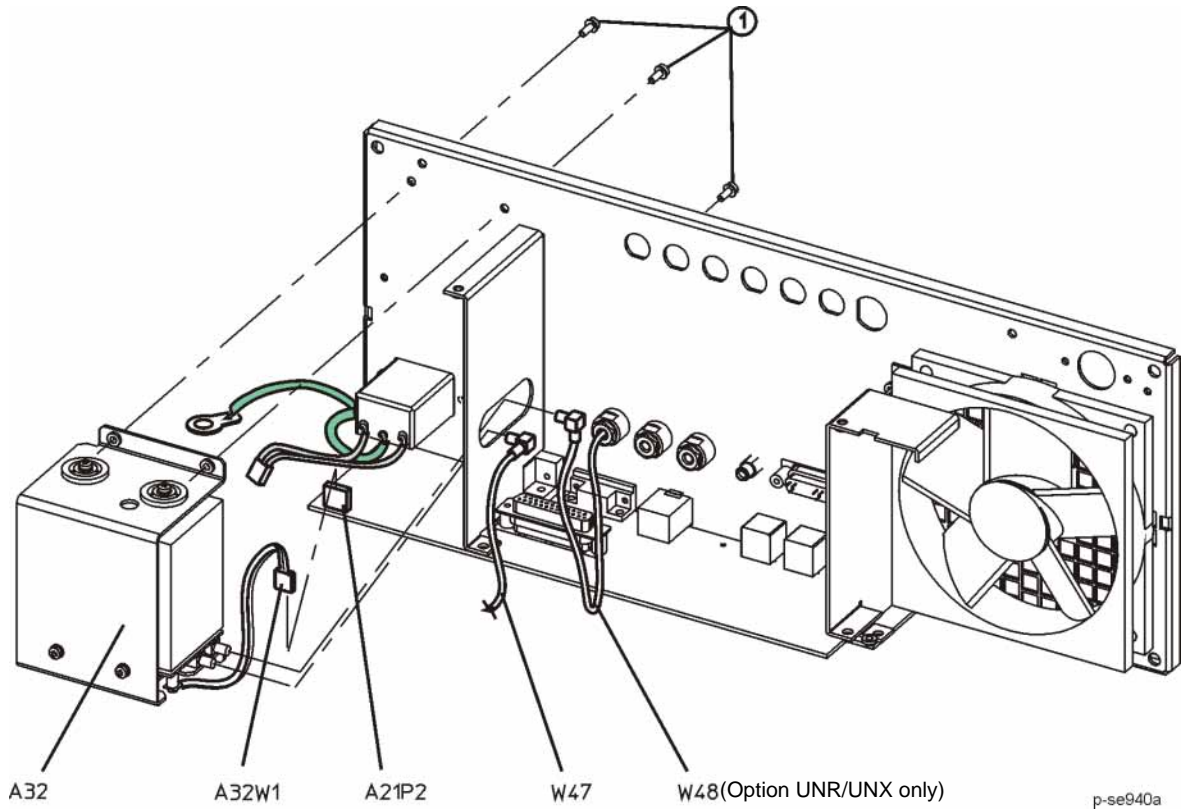

A33 6dB PAD (Options 503, 509, 520, and 521)

Tools Required

- 5/16" open-ended wrench
- needle-nose pliers

Removal Procedure

Refer to **Figure 3-55** for this procedure.

- 1. Disconnect the power cord.**
- 2. Remove the covers from the signal generator. Refer to “Outer Instrument Cover” on page 6 and “Inner Instrument Cover” on page 8.**
- 3. Using the 5/16" open-ended wrench, disconnect the A33 6dB PAD from the A24 20 GHz Highband Coupler.**
- 4. Using the 5/16" open-ended wrench, disconnect the A33 6dB PAD from the A25 20 GHz Highband Detector.**
- 5. Remove the A33 6dB PAD.**

Replacement Procedure

- Reverse the order of the removal procedure.
- Torque all RF connectors to 8 in-lbs.
- Perform the post-repair adjustments and performance tests that pertain to this removal procedure.

Assembly Replacement
A33 6dB PAD (Options 503, 509, 520, and 521)

Figure 3-55 A33 6dB PAD (Options 503, 509, 520, and 521)

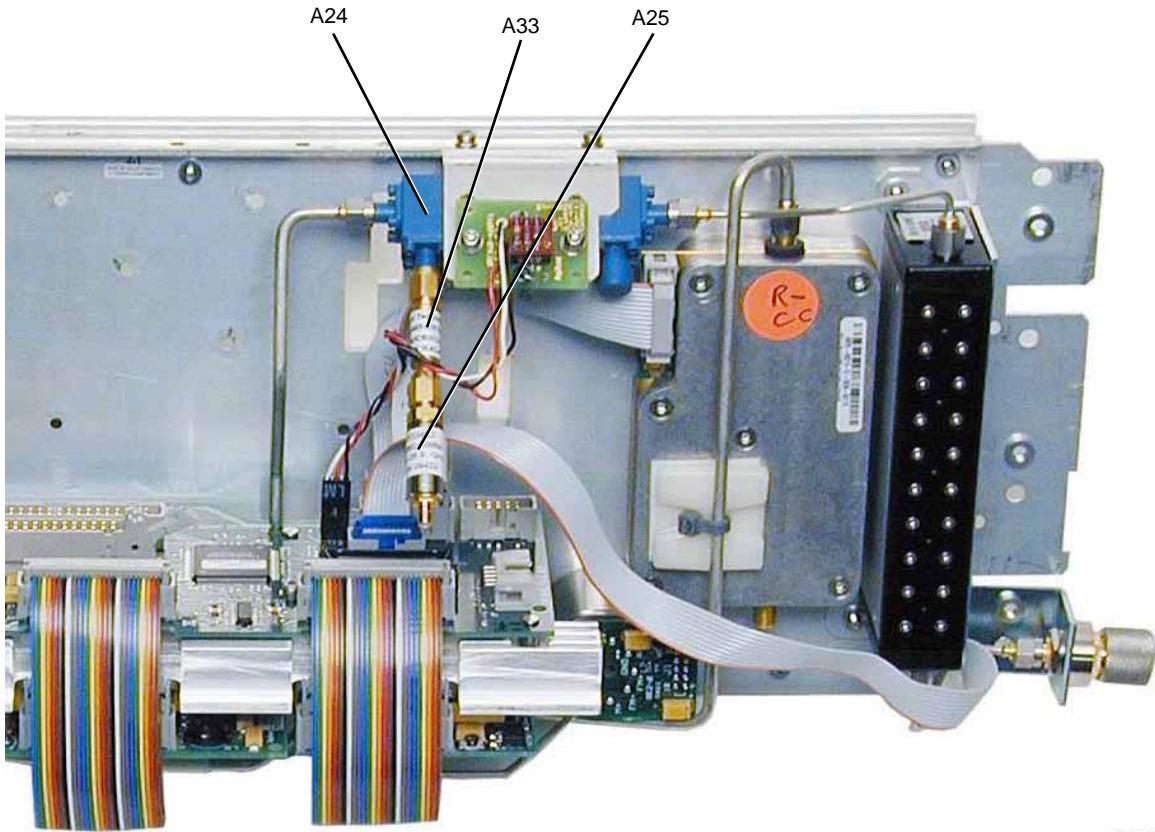

p2_a24

A33 10dB PAD (Options 532 and 544)

Tools Required

- 5/16" open-ended wrench
- needle-nose pliers

Removal Procedure

Refer to **Figure 3-56** for this procedure.

- 1. Disconnect the power cord.**
- 2. Remove the covers from the signal generator. Refer to “Outer Instrument Cover” on page 6 and “Inner Instrument Cover” on page 8.**
- 3. Using the 5/16" open-ended wrench, disconnect the A33 10dB PAD from the A24 50 GHz Highband Coupler.**
- 4. Using the 5/16" open-ended wrench, disconnect the A33 10dB PAD from the A25 50 GHz Highband Detector.**
- 5. Remove the A33 10dB PAD.**

Replacement Procedure

- Reverse the order of the removal procedure.
- Torque all RF connectors to 8 in-lbs.
- Perform the post-repair adjustments and performance tests that pertain to this removal procedure.

Assembly Replacement
A33 10dB PAD (Options 532 and 544)

Figure 3-56 A33 10dB PAD (Options 532 and 544)

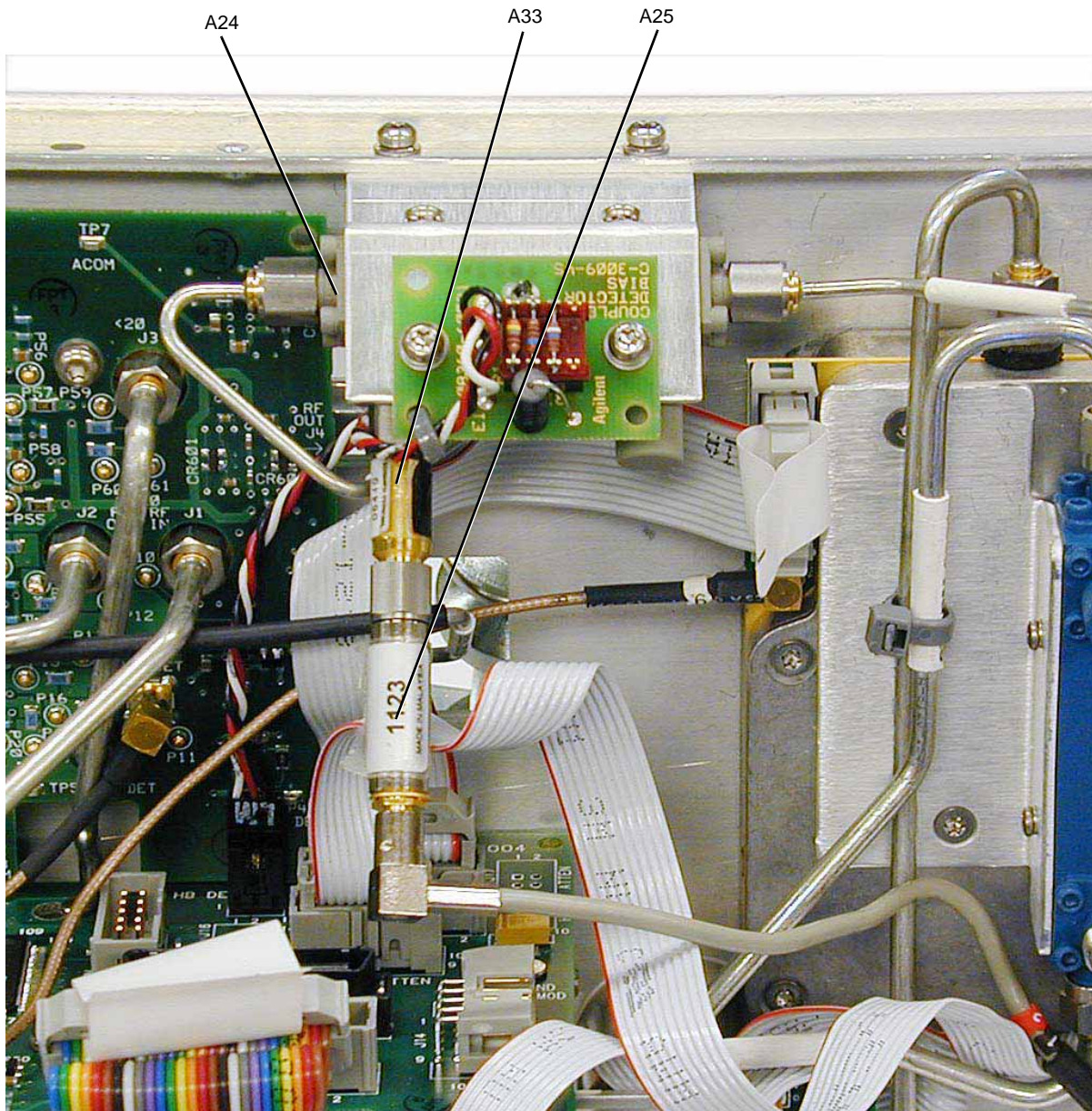

Rear Panel (Standard)

Tools Required

- T-10 driver
- needle-nose pliers
- 5/16" open-ended wrench

Removal Procedure

Refer to **Figure 3-57** for this procedure.

1. Disconnect the power cord.
2. Remove the covers from the signal generator. Refer to **“Outer Instrument Cover” on page 6** and **“Inner Instrument Cover” on page 8**.
3. Using the T-10 driver, remove the four screws from the Baseband Generator cover (E8267D only).
4. Position the signal generator with the A31 Motherboard panel facing you.
5. Using the needle-nose pliers, disconnect the following flexible cables:
 - W21 (10 MHz output) from A31 Motherboard J1043
 - W47 from A31 Motherboard J1041
 - W22 (10 MHz input) from A31 Motherboard J1042
 - W68 (BBG Rear Pwr) from A31 Motherboard J250 (E8267D only)
 - W80 (WIDEBAND I INPUT) from A35 3-20 GHz I/Q Modulator J106 (E8267D only)
 - W79 (WIDEBAND Q INPUT) from A35 3-20 GHz I/Q Modulator J9 (E8267D only)
6. Position the signal generator with the rear panel facing you.
7. Using the needle-nose pliers, disconnect the following flexible cables:
 - W55 (SOURCE MOD INTERFACE) from A10 ALC J304
 - W65 (BASEBAND GEN REF IN) from A14 Baseband Generator Board J800 (E8267D only)
 - W56 (- Q OUT) from A13 I/Q MUX J14 (E8267D only)
 - W57 (- I OUT) from A13 I/Q MUX J13 (E8267D only)
 - W58 (Q OUT) from A13 I/Q MUX J12 (E8267D only)
 - W59 (I OUT) from A13 I/Q MUX J11 (E8267D only)

- 8.** Using the 5/16" open-ended wrench, disconnect the following cables:
 - W67 (.25–3.2 GHz COH CARRIER) from the Rear Panel (E8267D only).
 - (1 GHz Out) from the Rear Panel.
- 9.** Disconnect the following ribbon cables:
 - W64 from A17P2 (E8267D only)
 - W90 from A17P1 (E8267D only)
 - W20 from A20 SMI J1
 - W18 from A21 Rear Panel Interface J3
 - W23 from A21 Rear Panel Interface J2
 - W136 from A40 Compact Flash PCA (if Option 008/009 is installed)
- 10.** If the signal generator has option UNR/UNIX, disconnect the W48 flexible cable from A32 10 MHz Crystal Oscillator (Option UNR/UNIX).
- 11.** Using the T-10 driver, remove the eleven screws (1) that secure the Rear Panel to the instrument chassis.
- 12.** Using the needle-nose pliers, disconnect A22W1 from the power supply.
- 13.** Using the T-10 driver, remove the screw securing the A22W2 to the A19 Power Supply.
- 14.** Disconnect the B1 Fan cable from the A31 Motherboard P251.
- 15.** Pull the rear panel away from the signal generator's chassis.

Replacement Procedure

- Reverse the order of the removal procedure.
- Torque all T-10 screws to 9 in-lbs.
- Torque all RF connectors to 8 in-lbs.
- Perform the post-repair adjustments and performance tests that pertain to this removal procedure.

Assembly Replacement
Rear Panel (Standard)

Figure 3-57

Rear Panel Removal

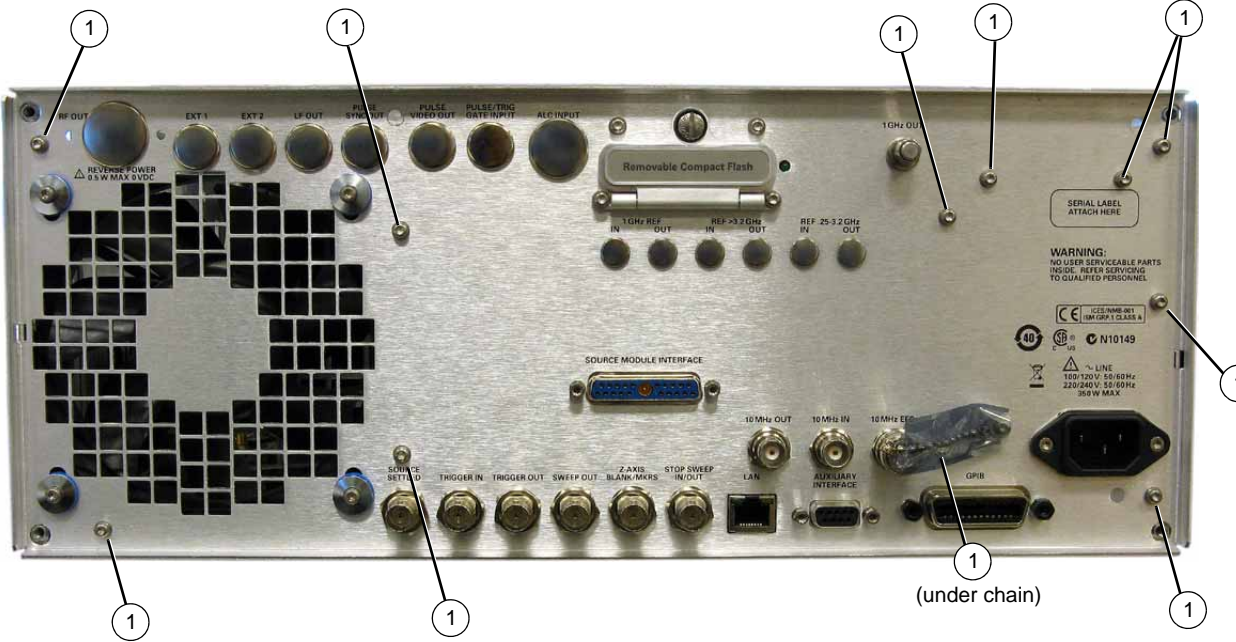

Rear Panel (Option 1EM)

Tools Required

- T-10 driver
- needle-nose pliers
- 5/16" open-ended wrench

Removal Procedure

Refer to **Figure 3-58** for this procedure.

1. Disconnect the power cord.
2. Remove the covers from the signal generator. Refer to **“Outer Instrument Cover” on page 6** and **“Inner Instrument Cover” on page 8**.
3. Using the T-10 driver, remove the four screws from the Baseband Generator cover (E8267D only).
4. Position the signal generator with the A31 Motherboard panel facing you.
5. Using the needle-nose pliers, disconnect the following flexible cables:
 - W21 (10 MHz output) from A31 Motherboard J1043
 - W47 from A31 Motherboard J1041
 - W22 (10 MHz input) from A31 Motherboard J1042
 - W51 (Data) from A31 Motherboard J500 (E8267D only)
 - W52 (Data Clock) from A31 Motherboard J501 (E8267D only)
 - W53 (SYMBOL SYNC) from A31 Motherboard J502 (E8267D only)
 - W68 (BBG Rear Pwr) from A31 Motherboard J250 (E8267D only)
 - W80 (WIDEBAND I INPUT) from A35 3-20 GHz I/Q Modulator J106 (E8267D only)
 - W79 (WIDEBAND Q INPUT) from A35 3-20 GHz I/Q Modulator J9 (E8267D only)
6. Using the needle-nose pliers, disconnect A22W1 from the power supply.
7. Position the signal generator with the rear panel facing you.
8. Using the needle-nose pliers, disconnect the following flexible cables:
 - W55 (SOURCE MOD INTERFACE) from A10 ALC J304.
 - W4 (ALC INPUT) from the A10 ALC J4

- W6 (PULSE VIDEO OUTPUT) from A11 Pulse/Analog Modulation Generator J203
 - W7 (PULSE SYNC OUTPUT) from A11 Pulse/Analog Modulation Generator J202
 - W5 (PULSE/TRIGGER GATE INPUT) from A11 Pulse/Analog Modulation Generator J201
 - W3 (LF OUTPUT) from A11 Pulse/Analog Modulation Generator J403
 - W2 (EXT 2 INPUT) from A11 Pulse/Analog Modulation Generator J402
 - W1 (EXT 1 INPUT) from A11 Pulse/Analog Modulation Generator J401
 - W56 (– Q OUT) from A13 I/Q MUX J14 (E8267D only)
 - W57 (– I OUT) from A13 I/Q MUX J13 (E8267D only)
 - W58 (Q OUT) from A13 I/Q MUX J12 (E8267D only)
 - W59 (I OUT) from A13 I/Q MUX J11 (E8267D only)
 - W50 (Q IN) from A13 I/Q MUX J8 (E8267D only)
 - W49 (I IN) from A13 I/Q MUX J7 (E8267D only)
 - W65 (BASEBAND GEN REF IN) from A14 Baseband Generator Board J800 (E8267D only)
- 9.** Using the 5/16” open-ended wrench, disconnect the following RF cables
- W67 (.25–3.2 GHz COH CARRIER) from Rear Panel
 - W73 from AT1 115 dB High-Power Mechanical Attenuator
 - (1 GHz Out) from the Rear Panel
- 10.** Disconnect the following ribbon cables:
- W64 from A17P2 (E8267D only)
 - W90 from A17P1 (E8267D only)
 - W20 from A20 SMI J1
 - W18 from A21 Rear Panel Interface J3
 - W23 from A21 Rear Panel Interface J2
 - W136 from A40 Compact Flash PCA (if Option 008/009 is installed)
- 11.** If the signal generator has option UNR/UNX, disconnect the W48 flexible cable from A32 10 MHz Crystal Oscillator (Option UNR/UNX).
- 12.** Using the T-10 driver, remove the two screws (1) that secure the Rear Panel to the left and right struts.

- 13.** Using the T-10 driver, remove the four screws (2) that attach the rear panel to the frame.
- 14.** Using the T-10 driver, remove the two screws (3) that secure the Rear Panel to the left and right struts.
- 15.** Using the T-10 driver, remove the screw securing the A22W2 to the A19 Power Supply.
- 16.** Disconnect the B1 Fan cable from the A31 Motherboard P251.
- 17.** Pull the rear panel away from the signal generator's chassis.

Replacement Procedure

- Reverse the order of the removal procedure.
- Torque all T-10 screws to 9 in-lbs.
- Torque all RF connectors to 8 in-lbs.
- Perform the post-repair adjustments and performance tests that pertain to this removal procedure.

Figure 3-58 Rear Panel Removal (Option 1EM)

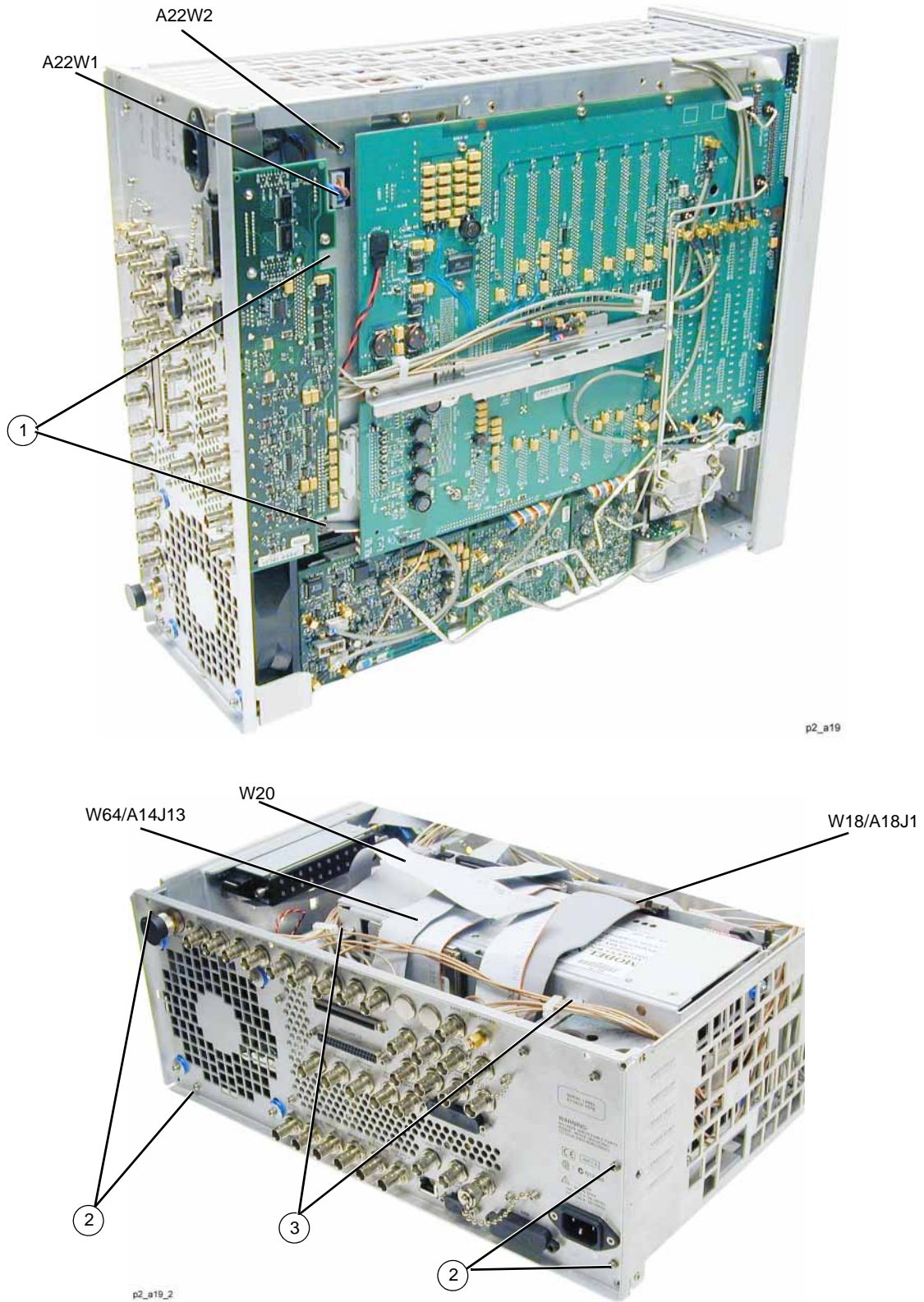

A34 Internal Hard Drive (E8267D Only - Discontinued)

Tools Required

- T-10 driver

Removal Procedure

Refer to **Figure 3-59** for this procedure.

1. Disconnect the power cord.
2. Remove the covers from the signal generator. Refer to “**Outer Instrument Cover**” on page 6 and “**Inner Instrument Cover**” on page 8.
3. Disconnect the W66 ribbon cable from the A18 CPU P2.
4. Using the T-10 driver, remove the screw (1) that attaches the A34 Internal Hard Drive to the A19 Power Supply.
5. Remove the A34 Internal Hard Drive.

Replacement Procedure

1. Reverse the order of the removal procedure.
2. Torque all T-10 screws to 9 in-lbs.
3. Perform the post-repair adjustments and performance tests that pertain to this removal procedure.

Assembly Replacement
A34 Internal Hard Drive (E8267D Only - Discontinued)

Figure 3-59 A34 Internal Hard Drive

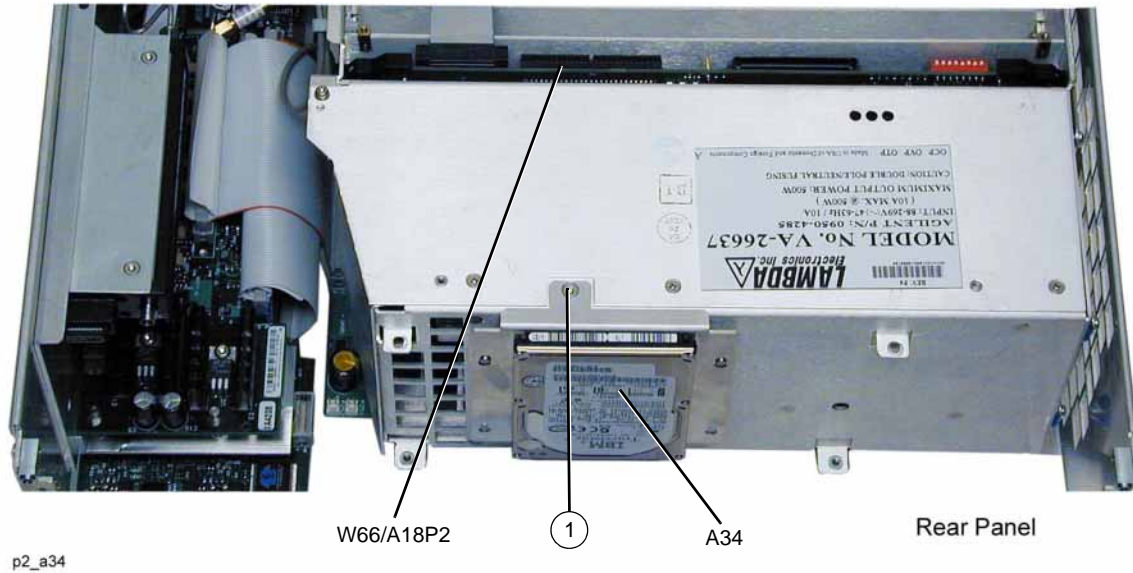

A35 3–20 GHz I/Q Modulator (E8267D Only – Standard or with Option 015)

Tools Required

- T–10 driver
- 5/16” open–ended wrench
- needle–nose pliers

Removal Procedure

Refer to **Figure 3-60** for this procedure.

1. Disconnect the power cord.
2. Remove the covers from the signal generator. Refer to “**Outer Instrument Cover**” on page 6 and “**Inner Instrument Cover**” on page 8.
3. Position the signal generator with the A31 Motherboard facing you and the RF deck on top.
4. Using the 5/16” open–ended wrench, disconnect the following RF cables:
 - W105 from A35J4
 - W77 from A35J1
 - W78 from A35 I/Q MOD
 - W104 from A35J3
5. Using the needle–nose pliers, disconnect the following flexible cables:
 - W62 from A35J7
 - W63 from A35J6
 - W79 from A35J9
 - W80 from A35J106
 - W97 from A35J8
6. Using the T–10 driver, remove the three screws (1) that attach the A35 I/Q MOD to the RF deck.
7. Disconnect the W70 ribbon cable from the A35 I/Q MOD.
8. Remove the A35 I/Q MOD from the RF deck.

Replacement Procedure

- Reverse the order of the removal procedure. (See the internal cover overlay for cable color codes.)

Assembly Replacement

A35 3–20 GHz I/Q Modulator (E8267D Only - Standard or with Option 015)

- Torque all T-10 screws to 9 in-lbs.
- Torque all RF connectors to 8 in-lbs.
- Perform the post-repair adjustments and performance tests that pertain to this removal procedure.

Figure 3-60 A35 3–20 GHz I/Q MOD

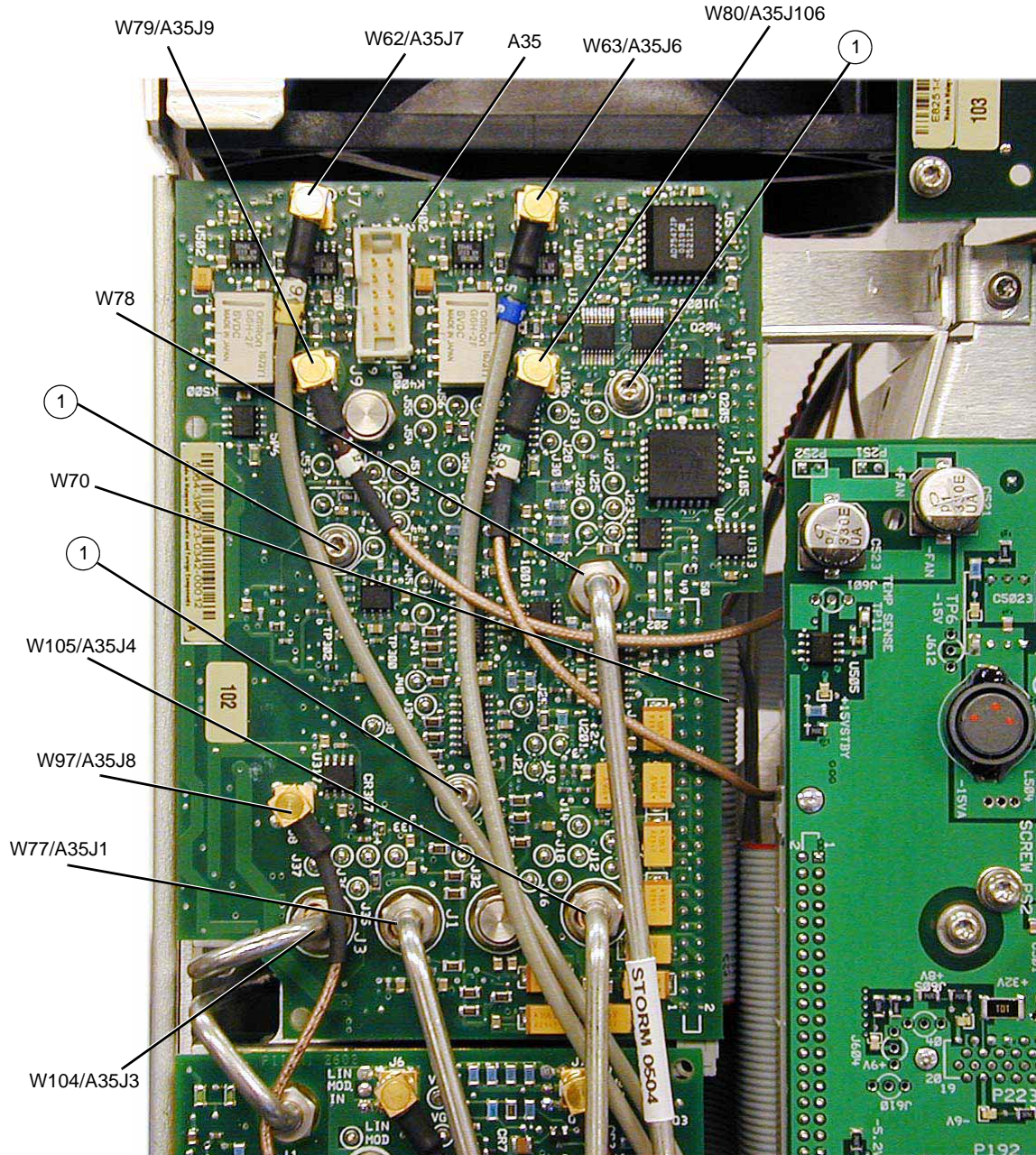

A35 3–20 GHz I/Q Modulator (E8267D Only - Standard or with Option H16/016) (Serial Prefixes >=US4722/MY4722)

Tools Required

- T–10 driver
- 5/16” open–ended wrench
- needle–nose pliers

Removal Procedure

Refer to **Figure 3-61** for this procedure.

1. Disconnect the power cord.
2. Remove the covers from the signal generator. Refer to “**Outer Instrument Cover**” on page 6 and “**Inner Instrument Cover**” on page 8.
3. Position the signal generator with the A31 Motherboard facing you and the RF deck on top.
4. Using the 5/16” open–ended wrench, disconnect the following RF cables:
 - W77 from A35J1
 - W134 from A35 I/Q Mod
5. Using the needle–nose pliers, disconnect the following flexible cables:
 - W62 from A35J7
 - W63 from A35J6
 - W127 from A35J109
 - W128 from A35J107
 - W129 from A35J108
 - W130 from A35J106
6. Using the T–10 driver, remove the three screws (1) that attach the A35 I/Q MOD to the RF deck.
7. Disconnect the W70 ribbon cable from the A35 I/Q MOD.
8. Remove the A35 I/Q MOD from the RF deck.

Replacement Procedure

- Reverse the order of the removal procedure. (See the internal cover overlay for cable color codes.)
- Torque all T–10 screws to 9 in–lbs.

Assembly Replacement

A35 3–20 GHz I/Q Modulator (E8267D Only - Standard or with Option H16/016) (Serial Prefixes >=US4722/MY4722)

- Torque all RF connectors to 8 in-lbs.
- Perform the post-repair adjustments and performance tests that pertain to this removal procedure.

Figure 3-61

A35 3–20 GHz I/Q MOD (E8267D only - Standard or with Option 016) (Serial Prefixes >US4722/MY4722)

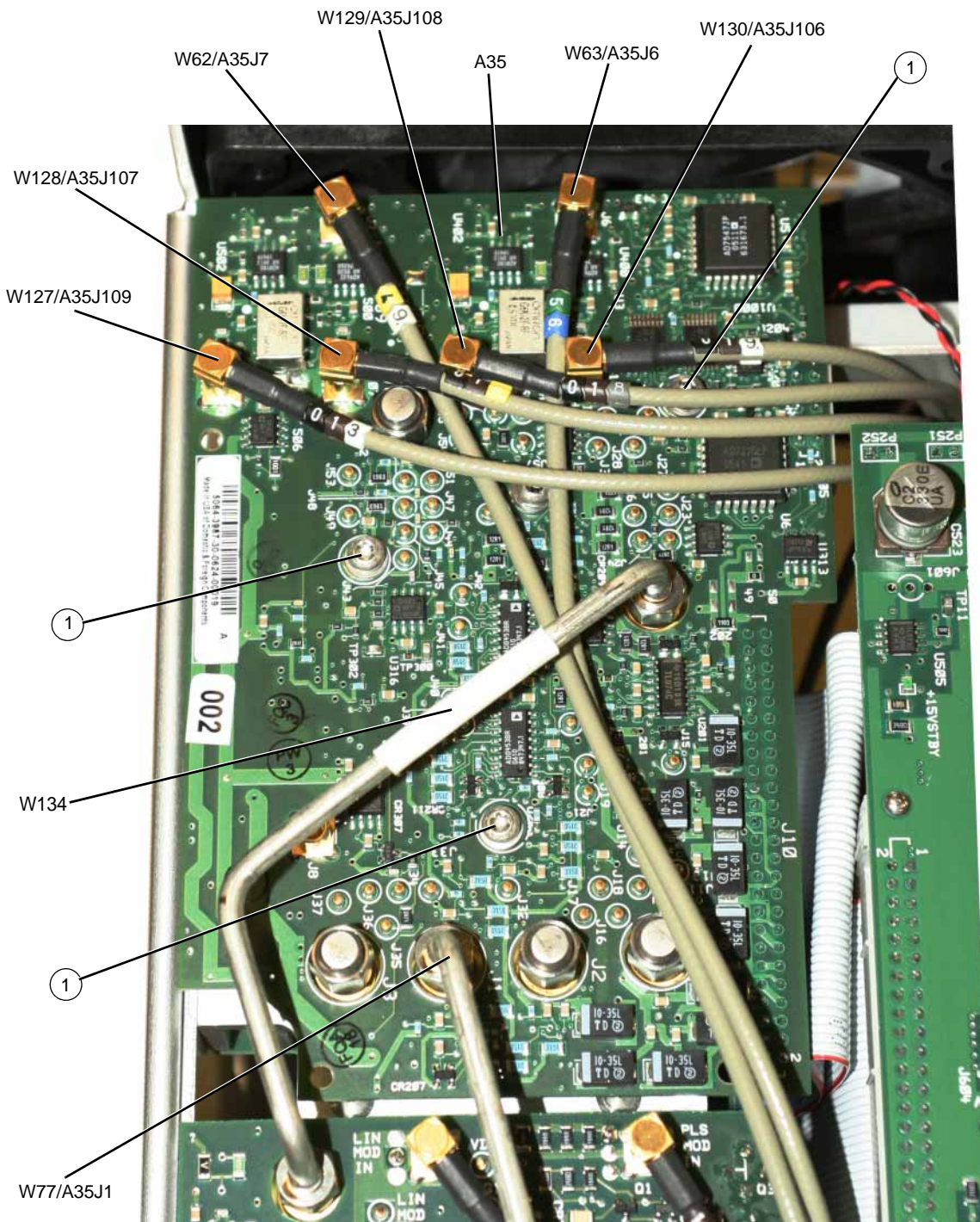

A36 Quadraplier (Options 550 and 567)

Tools Required

- T-10 driver
- 5/16" open-ended wrench

Removal Procedure

Refer to **Figure 3-62** for this procedure.

1. Disconnect the power cord.
2. Remove the covers from the signal generator. Refer to **“Outer Instrument Cover” on page 6** and **“Inner Instrument Cover” on page 8**.
3. Position the signal generator with the A31 Motherboard facing away from you and the RF deck on top.
4. Using the needle-nose pliers, disconnect the following flexible cables:
 - W108 from A36J4
 - W109 from A36J3
 - W110 from A36J6
 - W111 from A36J7
 - W96 from A36J5
5. Using the 5/16" open-ended wrench, disconnect the following RF cables:
 - W106 from A36J1
 - W107 from A36J2
 - W112 from A36J3/RF OUT
6. Using the T-10 driver, remove the four screws that attach the A36 Quadraplier board to the side panel.
7. Disconnect the W113 ribbon cable from the A36J10.
8. Remove the A36 Quadraplier from the RF deck.

Replacement Procedure

1. Reverse the order of the removal procedure.
2. Torque all T-10 screws to 9 in-lbs.
3. Torque all RF connectors to 8 in-lbs.
4. Perform the post-repair adjustments and performance tests that pertain to this removal procedure.

Assembly Replacement
A36 Quadraplier (Options 550 and 567)

Figure 3-62 A36 Quadraplier

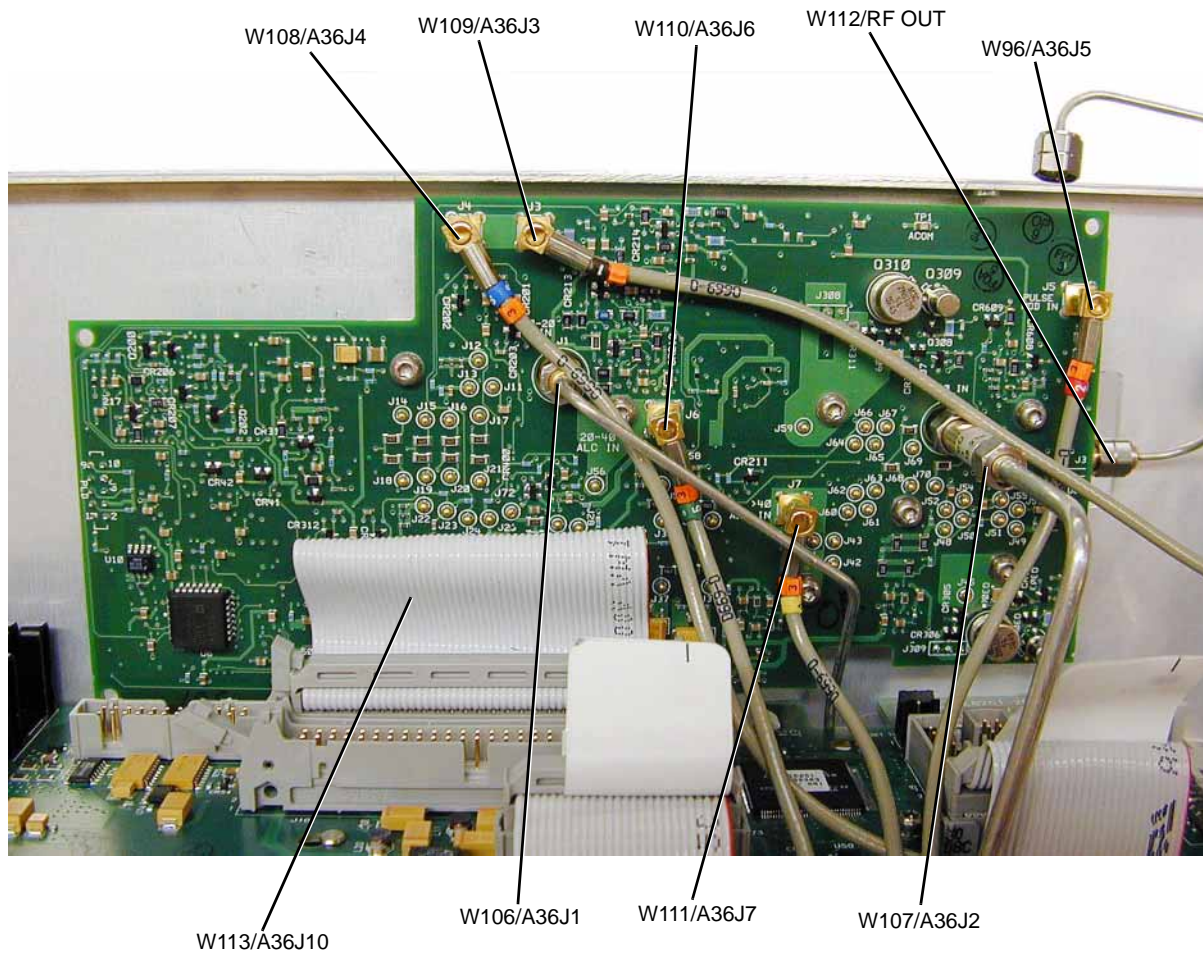

A37 Upconverter (E8267D Only)

Tools Required

- T-10 driver
- 5/16" open-ended wrench
- needle-nose pliers

Removal Procedure

Refer to **Figure 3-63** for this procedure.

- 1. Disconnect the power cord.**
- 2. Remove the covers from the signal generator. Refer to “Outer Instrument Cover” on page 6 and “Inner Instrument Cover” on page 8.**
- 3. Position the signal generator with the A31 Motherboard facing you and the RF deck on top.**
- 4. Using the 5/16" open-ended wrench, disconnect the following RF cable:**
 - W98 from A37J2
 - W103 from A27J3
 - W102 from A37J4
 - W78 from A37J1
- 5. Using the needle-nose pliers, disconnect the following flexible cables:**
 - W114 from A37J9
 - W97 from A37J8
- 6. Using the T-10 driver, remove the three screws that attach the A37 Upconverter to the RF deck.**
- 7. Disconnect the W99 ribbon cable from the A37J7.**
- 8. Remove the A37 Upconverter from the RF deck.**

Replacement Procedure

- Reverse the order of the removal procedure.
- Torque all T-10 screws to 9 in-lbs.
- Torque all RF connectors to 8 in-lbs.
- Perform the post-repair adjustments and performance tests that pertain to this removal procedure.

Assembly Replacement
A37 Upconverter (E8267D Only)

Figure 3-63 A37 Upconverter

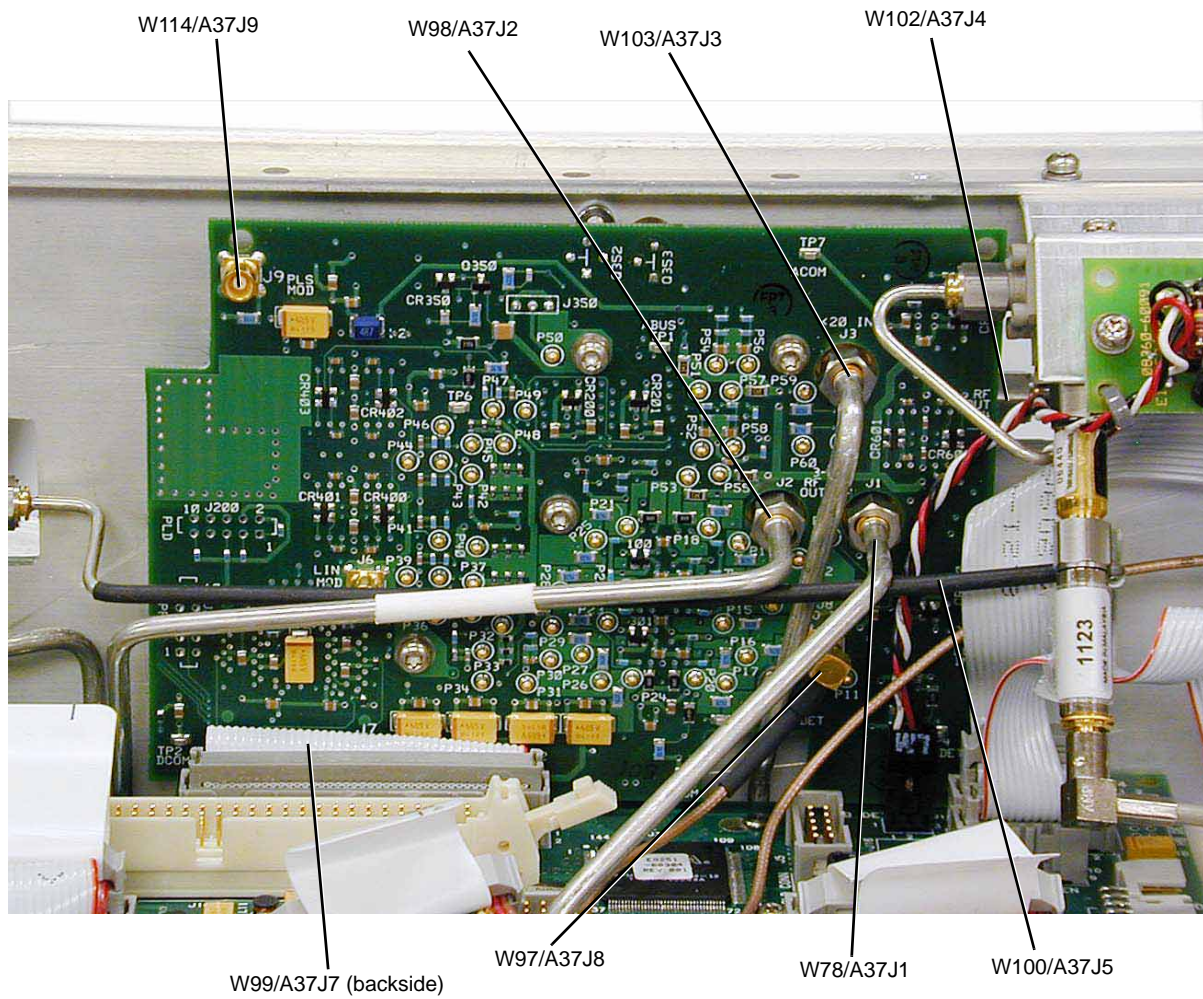

A38 Lowband Switch Filter

Tools Required

- none

Removal Procedure

Refer to **Figure 3-70** for this procedure.

1. Disconnect the power cord.
2. Remove the covers from the signal generator. Refer to “**Outer Instrument Cover**” on page 6 and “**Inner Instrument Cover**” on page 8.
3. Position the signal generator with the front panel facing you.
4. Lift the retention levers and disconnect the board assembly from the A31 Motherboard.
5. Lift the board assembly out of the slot.

Replacement Procedure

1. Reverse the order of the removal procedure.
2. Perform the post-repair adjustments and performance tests that pertain to this removal procedure.

Assembly Replacement
A38 Lowband Switch Filter

Figure 3-64 A38 Low Band Switch Filter

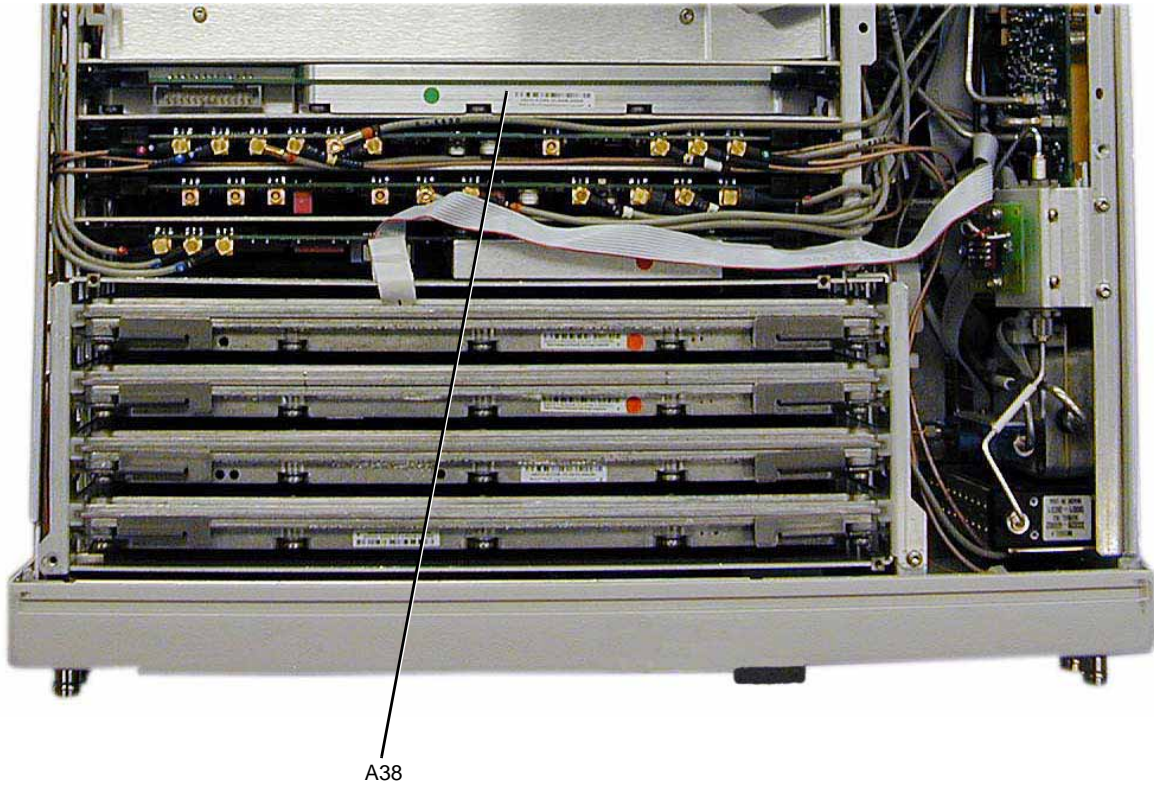

A39 Directional Sweep Coupler

Tools Required

- T-10 driver
- 5/16" open-ended wrench

Removal Procedure

Refer to **Figure 3-65** for this procedure.

1. Disconnect the power cord.
2. Remove the covers from the signal generator. Refer to **“Outer Instrument Cover” on page 6** and **“Inner Instrument Cover” on page 8**.
3. Position the signal generator with the A31 Motherboard facing away from you and the RF deck on top.
4. Using the 5/16" open-ended wrench, disconnect the following RF cables:
 - W101 from A39 (IN)
 - W115 from A39 (OUT)
5. Using the T-10 driver, remove the two screws that attach the A39 Directional Sweep Coupler to the A23 Lowband Coupler/Detector.
6. Remove the A39 Directional Sweep Coupler from the RF deck.

Replacement Procedure

1. Reverse the order of the removal procedure.
2. Torque all T-10 screws to 9 in-lbs.
3. Torque all RF connectors to 8 in-lbs.
4. Perform the post-repair adjustments and performance tests that pertain to this removal procedure.

Assembly Replacement
A39 Directional Sweep Coupler

Figure 3-65 A39 Directional Sweep Coupler

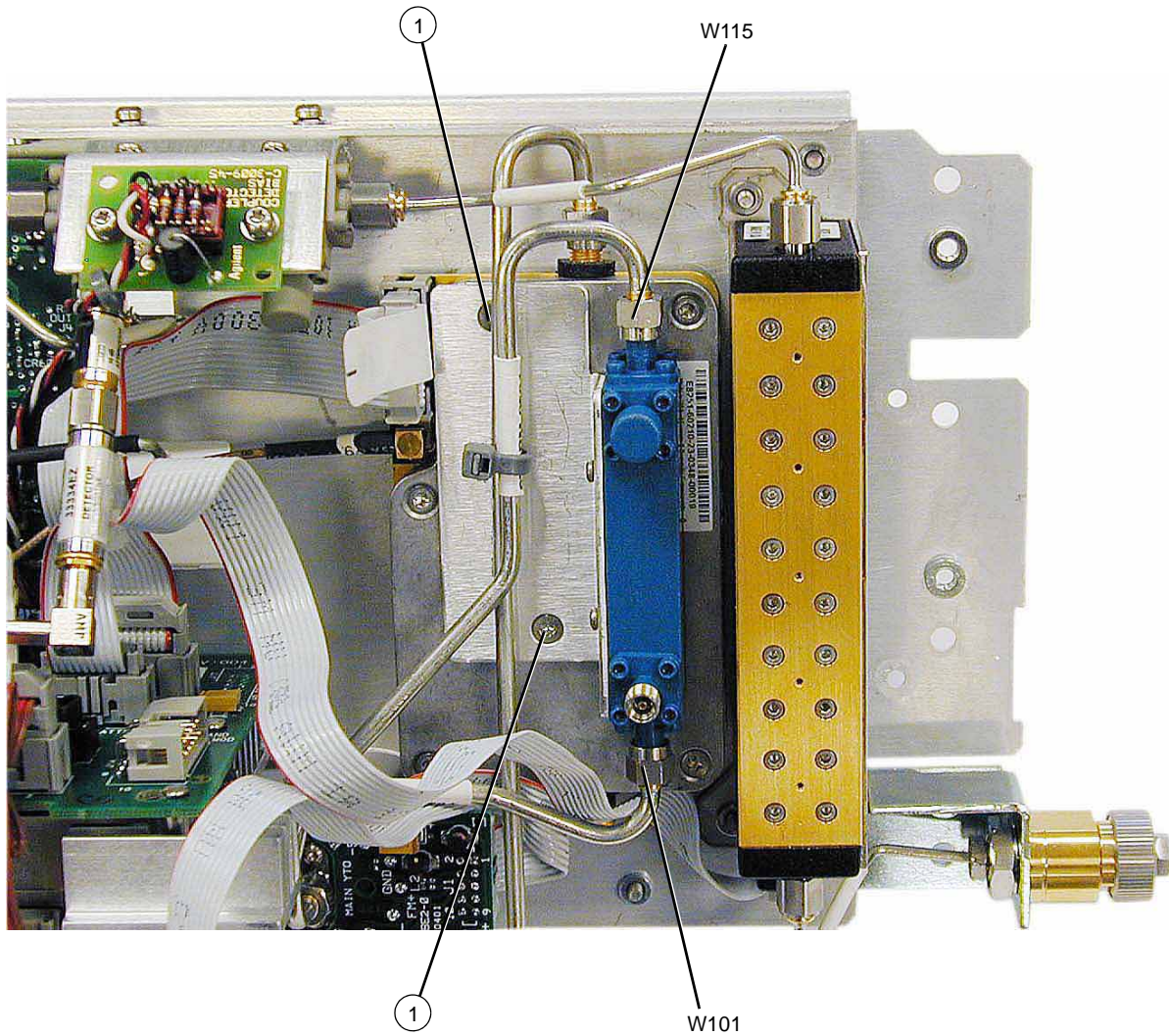

A40 Compact Flash Drive Assembly

Tools Required

- T-10 driver
- Standard Screwdriver

Removal Procedure

Refer to **Figure 3-66** and **Figure 3-67** for this procedure.

1. Disconnect the power cord.
2. Remove the covers from the signal generator. Refer to “**Outer Instrument Cover**” on page 6 and “**Inner Instrument Cover**” on page 8.
3. Disconnect the W66 ribbon cable from A18P2.
4. Using the standard screwdriver, unlock the A41 door latch screw by rotating counter-clockwise.
5. Remove the flash card (if applicable).
6. Using the T-10 driver, remove the two upper screws (1) that attach the A40 PCA/CF drive assembly to the rear panel.

Replacement Procedure

1. Reverse the order of the removal procedure.
2. Torque all T-10 screws to 9 in-lbs.
3. Perform the post-repair adjustments and performance tests that pertain to this removal procedure.

Figure 3-66 A40 Flash Drive Assembly

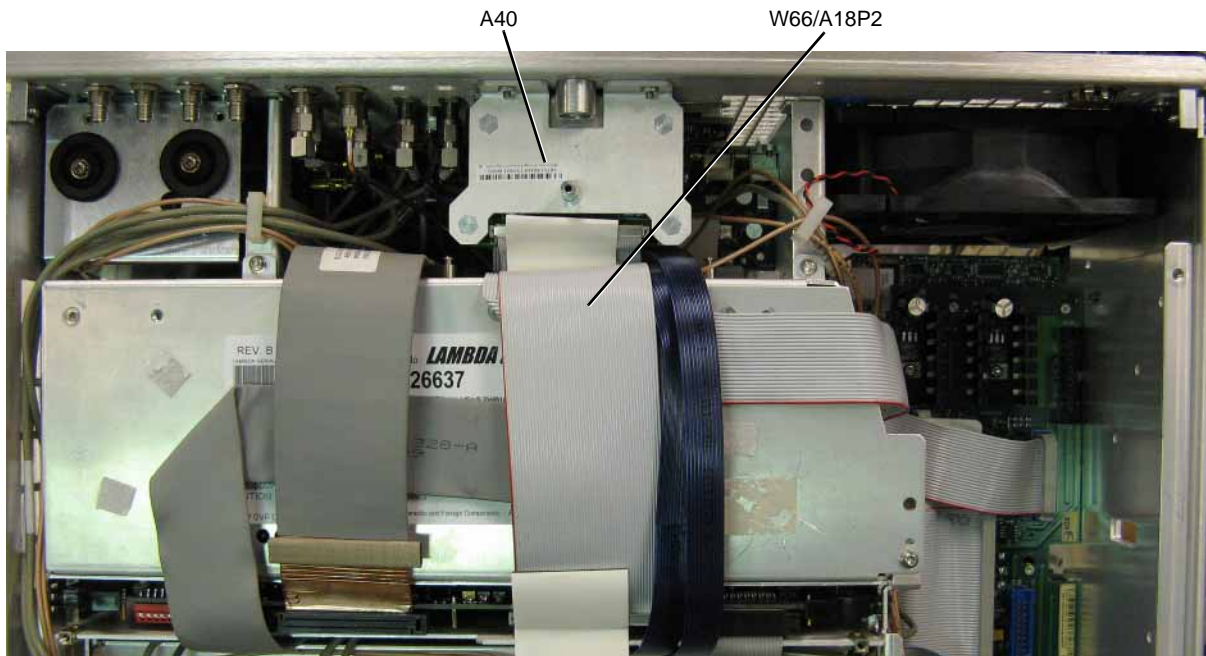

Figure 3-67 A41 Flash Drive Door Assembly



A41 Flash Drive Door Assembly

Tools Required

- T-10 driver
- Standard Screwdriver

Removal Procedure

Refer to **Figure 3-68** for this procedure.

- 1. Disconnect the power cord.**
- 2. Using the standard screwdriver, unlock the door latch screw by rotating counter-clockwise.**
- 3. Remove the flash card (if applicable).**
- 4. Using the T-10 driver, remove the two lower screws (1) that attach the A41 door assembly to the rear panel.**

Note: The screws act as retainers to keep the hinge pins from sliding out.

Replacement Procedure

- 1. Reverse the order of the removal procedure.**
- 2. Torque all T-10 screws to 9 in-lbs.**
- 3. Perform the post-repair adjustments and performance tests that pertain to this removal procedure.**

Figure 3-68 A41 Flash Drive Door Assembly



A42 20 GHz Power Amp (Option 521)

Tools Required

- T-10 driver
- 5/16" open-ended wrench

Removal Procedure

Refer to **Figure 3-69** for this procedure.

1. Disconnect the power cord.
2. Remove the outer cover from the signal generator. Refer to **“Outer Instrument Cover” on page 6**.
3. Position the signal generator with the A31 Motherboard facing you and the RF deck on top.
4. Disconnect W135 from the A42 20 GHz Power Amp board.
5. Using the 5/16" open-ended wrench, disconnect the following RF cables according to the signal generator you have.

Standard: Disconnect W141 and W142 from the A42 20 GHz Power Amp board.

Option 1EM: Disconnect W141 and W143 from the A42 20 GHz Power Amp board.

6. Using the T-10 drive, remove the three screws (1) that secure the A42 20 GHz Power Amp board to the RF deck.
7. Remove the A42 20 GHz Power Amp from the RF deck.

Replacement Procedure

1. Reverse the order of the removal procedure.
2. Torque all T-10 screws to 9 in-lbs.
3. Perform the post-repair adjustments and performance tests that pertain to this removal procedure.

Assembly Replacement
A42 20 GHz Power Amp (Option 521)

Figure 3-69 A42 20 GHz Power Amp

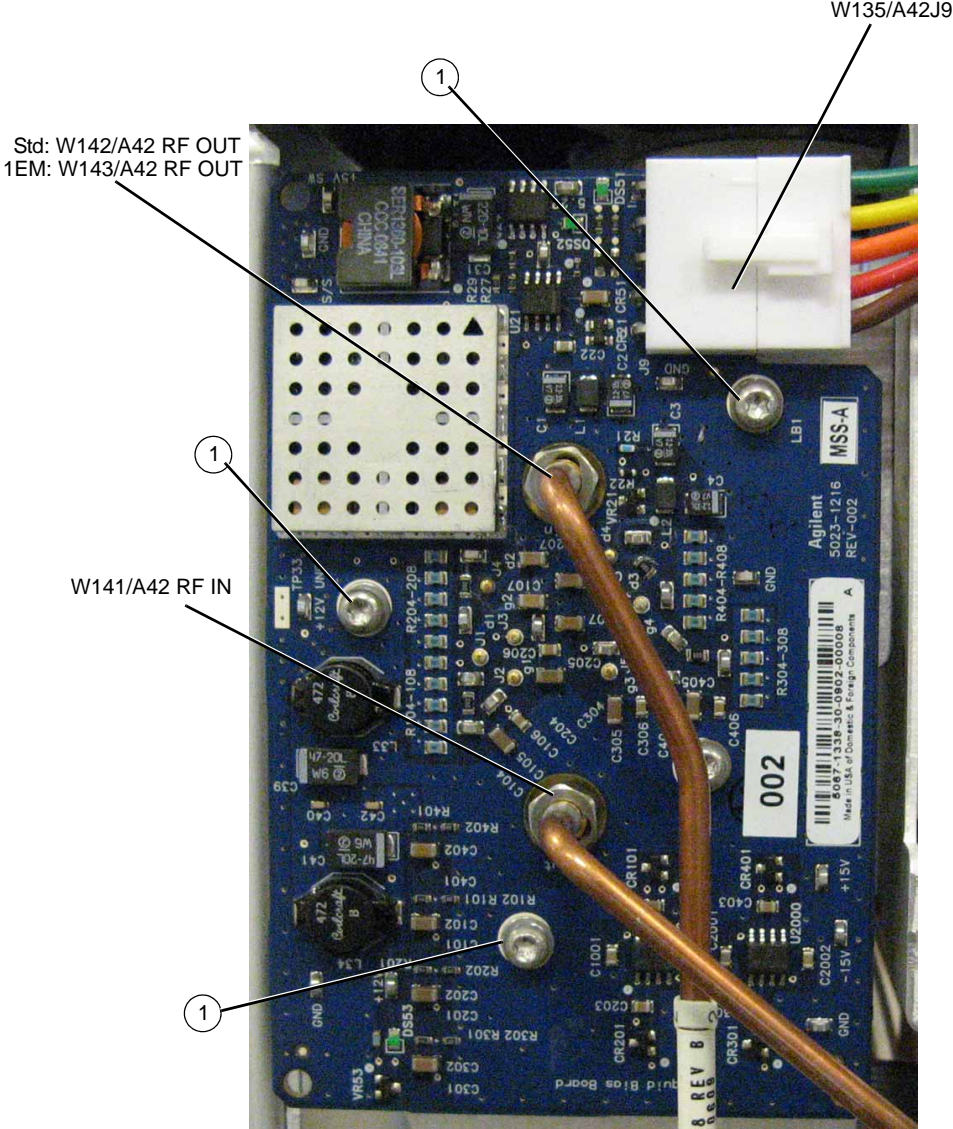

A43 Lowband Amp Filter

Tools Required

- none

Removal Procedure

Refer to **Figure 3-70** for this procedure.

1. Disconnect the power cord.
2. Remove the covers from the signal generator. Refer to “**Outer Instrument Cover**” on page 6 and “**Inner Instrument Cover**” on page 8.
3. Position the signal generator with the front panel facing you.
4. Using the 5/16” open-ended wrench, disconnect W140 from the A38 Low Band Switch Filter board.
5. Using the needle-nose pliers, disconnect W139 from the A43 Lowband Amp Filter board.
6. Lift the retention levers and disconnect the A43 Lowband Amp Filter board from the A31 Motherboard.
7. Lift the A43 Lowband Amp Filter board out of the slot.

Replacement Procedure

1. Reverse the order of the removal procedure.
2. Perform the post-repair adjustments and performance tests that pertain to this removal procedure.

Assembly Replacement
A43 Lowband Amp Filter

Figure 3-70 A43 Lowband Amp Filter

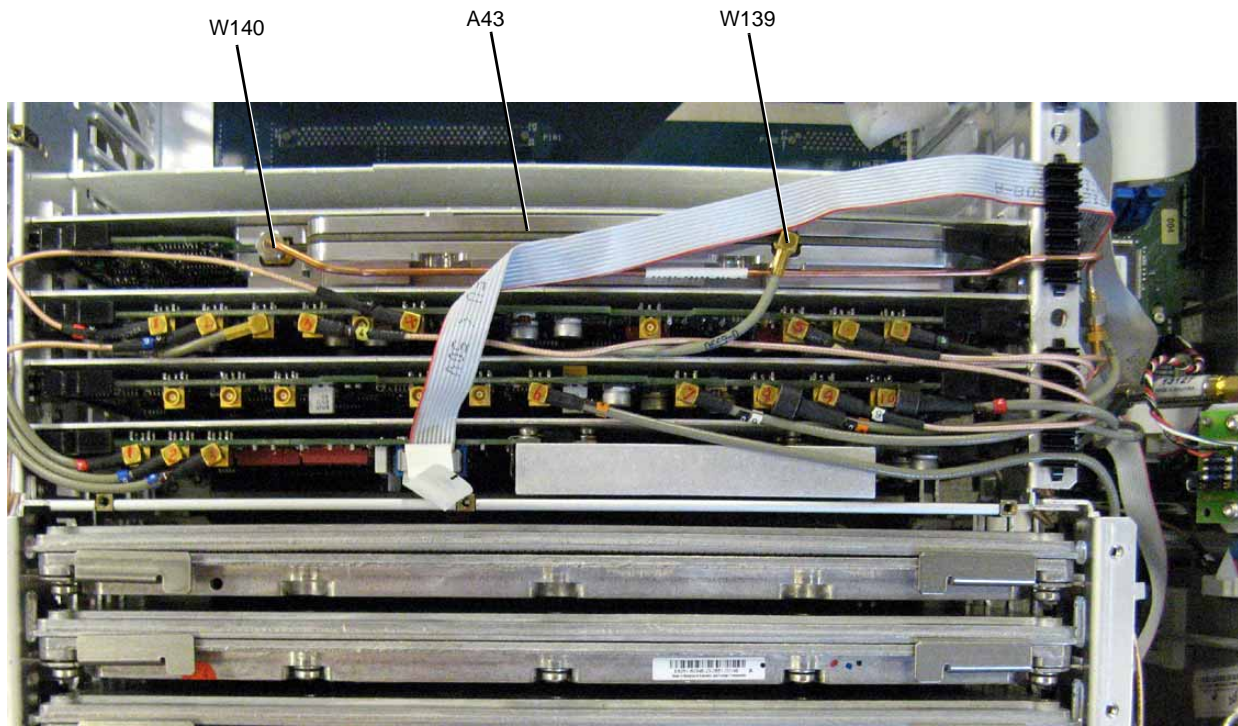

A44 Scan Modulation Bias Adapter (E8257D-520 and E8663D Only)

Tools Required

- needle-nose pliers
- 5/16" open-ended wrench
- T-10 driver

Removal Procedure

Refer to **Figure 3-71** for this procedure.

1. Disconnect the power cord.
2. Remove the covers from the signal generator. Refer to **"Outer Instrument Cover" on page 6** and **"Inner Instrument Cover" on page 8**.
3. Position the signal generator with the A31 Motherboard facing away from you and the RF deck on top.
4. Using the needle-nose pliers, disconnect W148 from A44J2.
5. Using the 5/16" open-ended wrench, disconnect the following RF cables:
 - W149 from the A44 assembly
 - W150 from AM MOD BIAS
6. Using the T-10 driver, remove the two screws (1) that attach the A44 Scan Modulation Bias Adapter and bracket to the side panel.
7. Disconnect the W151 ribbon cable from A26J33.
8. Remove the A44 Scan Modulation Bias Adapter from the RF deck.

Replacement Procedure

1. Reverse the order of the removal procedure.
2. Perform the post-repair adjustments and performance tests that pertain to this removal procedure.

Assembly Replacement
A44 Scan Modulation Bias Adapter (E8257D-520 and E8663D Only)

Figure 3-71

A44 Scan Modulation Bias Adapter

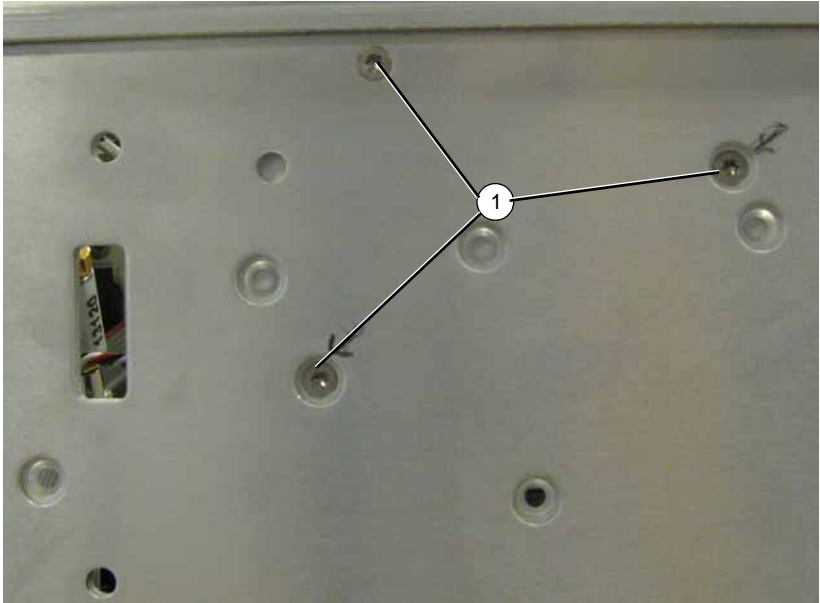
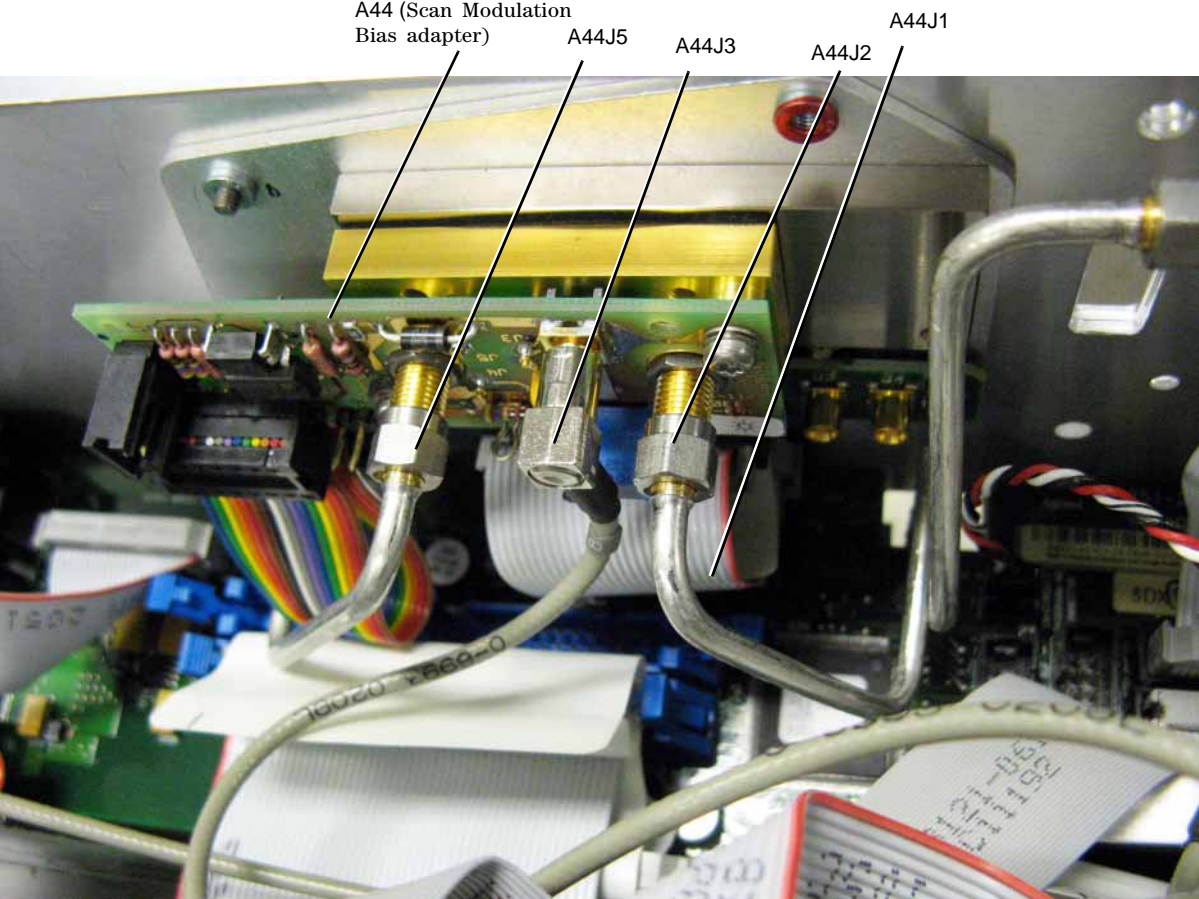

AT1 90 dB Attenuator

Tools Required

- T-10 driver
- 5/16" open-ended wrench

Removal Procedure

Refer to **Figure 3-72** for this procedure.

1. Disconnect the power cord.
2. Remove the covers from the signal generator. Refer to **“Outer Instrument Cover” on page 6** and **“Inner Instrument Cover” on page 8**.
3. Position the signal generator with the A31 Motherboard facing you so that the RF deck is on top.
4. Using the 5/16" open-ended wrench, disconnect the W117 and W92 RF cables from the AT1 90 dB Attenuator.

NOTE

Cables W117 and W92 are easily damaged. DO NOT bend them. Bending the cables can damage the center conductor, which could result in power “holes”.

5. Using the T-10 driver, remove the two screws that attach the AT1 90 dB Attenuator to the side panel.
6. Disconnect the AT1W1 ribbon cable from A26J13.
7. Remove the attenuator from the A26 MID bracket.
8. Using the T-10 driver, remove the sheet metal from the AT1 90 dB attenuator.

Replacement Procedure

1. Reverse the order of the removal procedure.
2. Torque all T-10 screws to 9 in-lbs.
3. Torque all RF connectors to 8 in-lbs.
4. Perform the post-repair adjustments and performance tests that pertain to this removal procedure.

Assembly Replacement
AT1 90 dB Attenuator

Figure 3-72 AT1 90 dB Attenuator

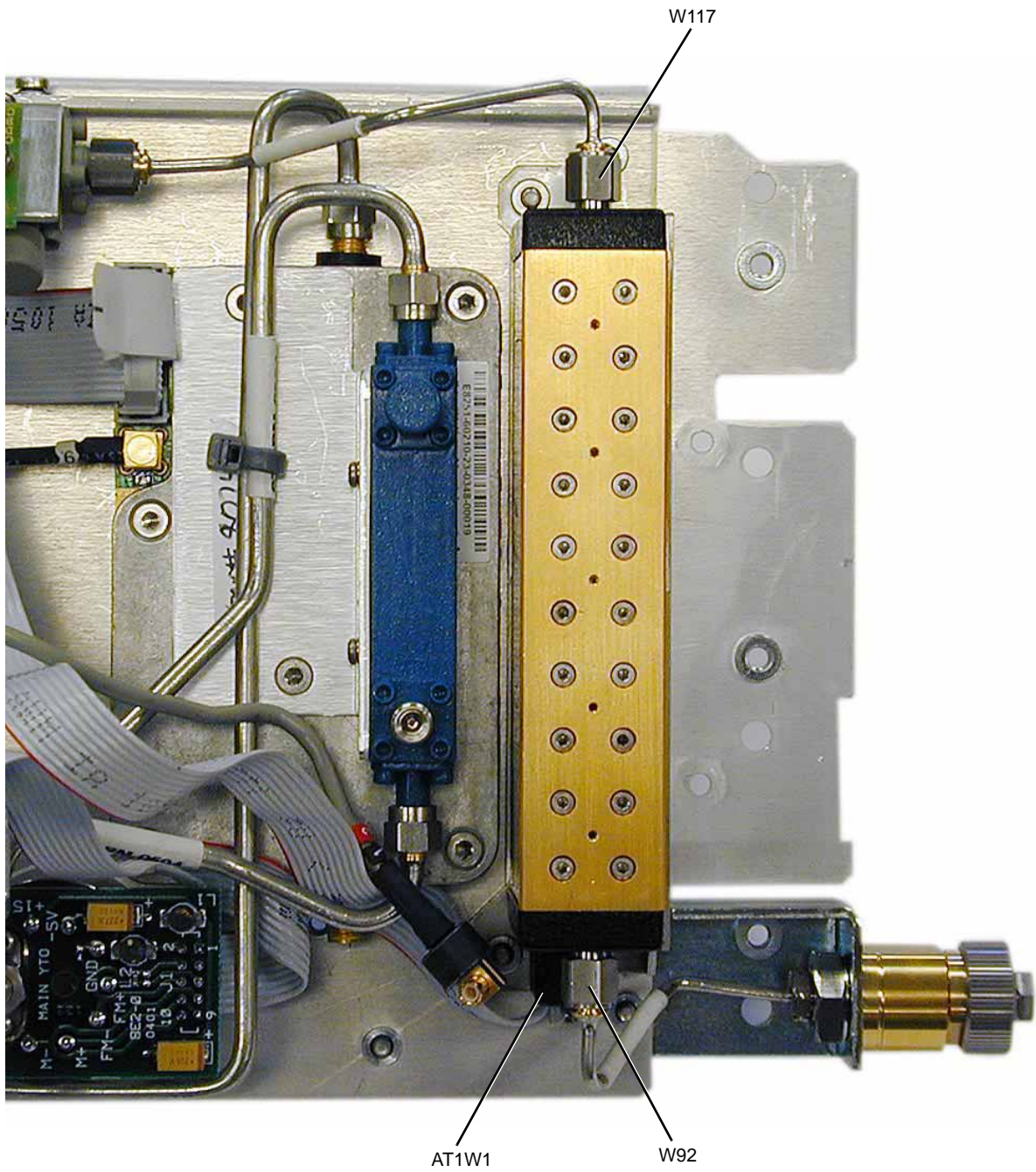

AT1 115 dB Attenuator

Tools Required

- T-10 driver
- 5/16" open-ended wrench

Removal Procedure

Refer to **Figure 3-73** for this procedure.

1. Disconnect the power cord.
2. Remove the covers from the signal generator. Refer to “**Outer Instrument Cover**” on page 6 and “**Inner Instrument Cover**” on page 8.
3. Position the signal generator with the A31 Motherboard facing you so that the RF deck is on top.
4. Using the 5/16" open-ended wrench, disconnect the following RF cables according to the signal generator you have.

Option 520, 532, 540, 544 or E8257N: Disconnect W24 and W25 from the AT1 115 dB Attenuator.

Option 521: Disconnect W143 and W145 from the AT1 115 dB Attenuator.

NOTE

Cables W24, W25, W143, and W145 are easily damaged. DO NOT bend them. Bending the cables can damage the center conductor, which could result in power “holes”.

5. Using the T-10 driver, remove the two screws (1) that attach the AT1 115 dB Attenuator to the side panel.
6. Disconnect the AT1W1 ribbon cable from A26J13.
7. Remove the attenuator from the A26 MID bracket.
8. Using the T-10 driver, remove the sheet metal from the attenuator.

Replacement Procedure

1. Reverse the order of the removal procedure.
2. Torque all T-10 screws to 9 in-lbs.
3. Torque all RF connectors to 8 in-lbs.
4. Perform the post-repair adjustments and performance tests that pertain to this removal procedure.

Figure 3-73

AT1 115 dB Attenuator

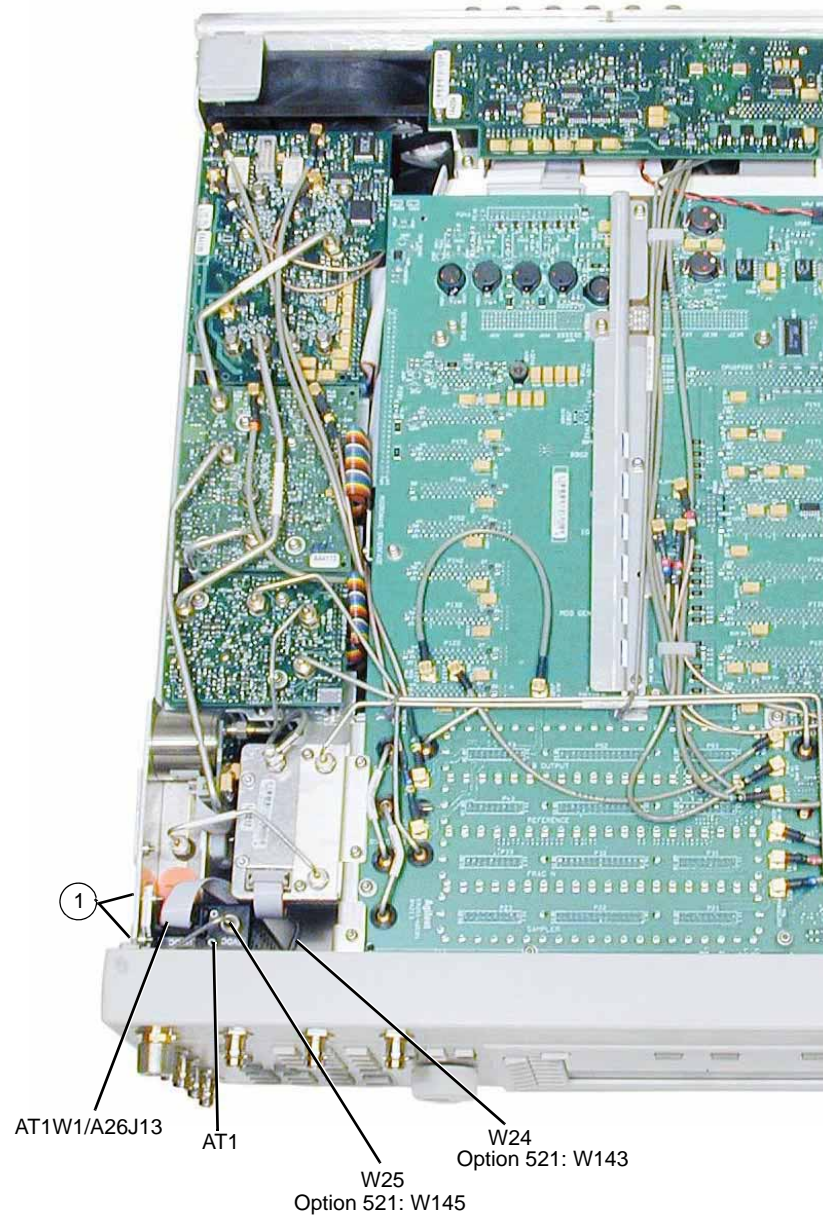

AT1 90 dB Attenuator (Option 1EM)

Tools Required

- T-10 driver
- 5/16" open-ended wrench

Removal Procedure

Refer to **Figure 3-74** for this procedure.

1. Disconnect the power cord.
2. Remove the covers from the signal generator. Refer to “**Outer Instrument Cover**” on page 6 and “**Inner Instrument Cover**” on page 8.
3. Position the signal generator with the A31 Motherboard facing you so that the RF deck is on top.
4. Disconnect the AT1W1 ribbon cable from A26J13.
5. Using the 5/16" open-ended wrench, disconnect the W81 and W94 RF cables from the AT1 90 dB Attenuator.

NOTE

Cables W81 and W94 are easily damaged. DO NOT bend them. Bending the cables can damage the center conductor, which could result in power "holes".

6. Using the T-10 driver, remove the two screws that attach the AT1 90 dB Attenuator to the side panel.
7. Remove the AT1 90 dB Attenuator.
8. Using the T-10 driver, remove the sheet metal from the attenuator.

Replacement Procedure

1. Reverse the order of the removal procedure.
2. Torque all T-10 screws to 9 in-lbs.
3. Torque all RF connectors to 8 in-lbs.
4. Perform the post-repair adjustments and performance tests that pertain to this removal procedure.

Assembly Replacement
AT1 90 dB Attenuator (Option 1EM)

Figure 3-74 AT1 90 dB Attenuator (Options 1EM)

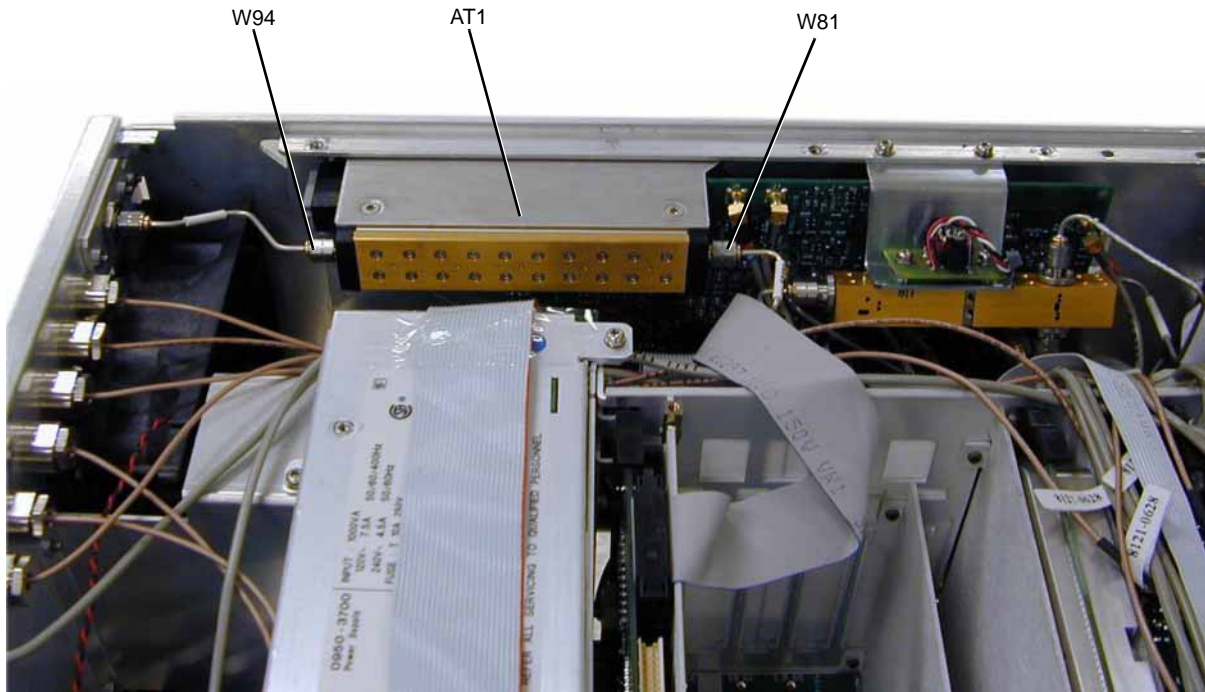

AT1 115 dB Attenuator (Option 1EM)

Tools Required

- T-10 driver
- 5/16" open-ended wrench

Removal Procedure

Refer to **Figure 3-75** for this procedure.

1. Disconnect the power cord.
2. Remove the covers from the signal generator. Refer to “**Outer Instrument Cover**” on page 6 and “**Inner Instrument Cover**” on page 8.
3. Position the signal generator with the A31 Motherboard facing you so that the RF deck is on top.
4. Disconnect the AT1W1 ribbon cable from A26J13.
5. Using the 5/16" open-ended wrench, disconnect the following RF cables according to the signal generator you have.

Options 503, 509, 520, and 540: Disconnect the W72 and W73 RF cables from the AT1 115 dB Attenuator.

Option 521: Disconnect the W146 and W147 RF cables from the AT1 115 dB Attenuator

Options 532 and 544: Disconnect the W93 and W85 RF cables from the AT1 115 dB Attenuator.

NOTE Cables W72, W73, W85, W93, W146, and W147 are easily damaged. DO NOT bend them. Bending the cables can damage the center conductor, which could result in power “holes”.

6. Using the T-10 driver, remove the two screws that attach the AT1 115 dB Attenuator to the side panel.
7. Remove the AT1 115 dB Attenuator.
8. Using the T-10 driver, remove the sheet metal from the attenuator.

Replacement Procedure

1. Reverse the order of the removal procedure.
2. Torque all T-10 screws to 9 in-lbs.
3. Torque all RF connectors to 8 in-lbs.

Assembly Replacement
AT1 115 dB Attenuator (Option 1EM)

4. Perform the post-repair adjustments and performance tests that pertain to this removal procedure.

Figure 3-75 AT1 115dB Attenuator (Option 1EM)

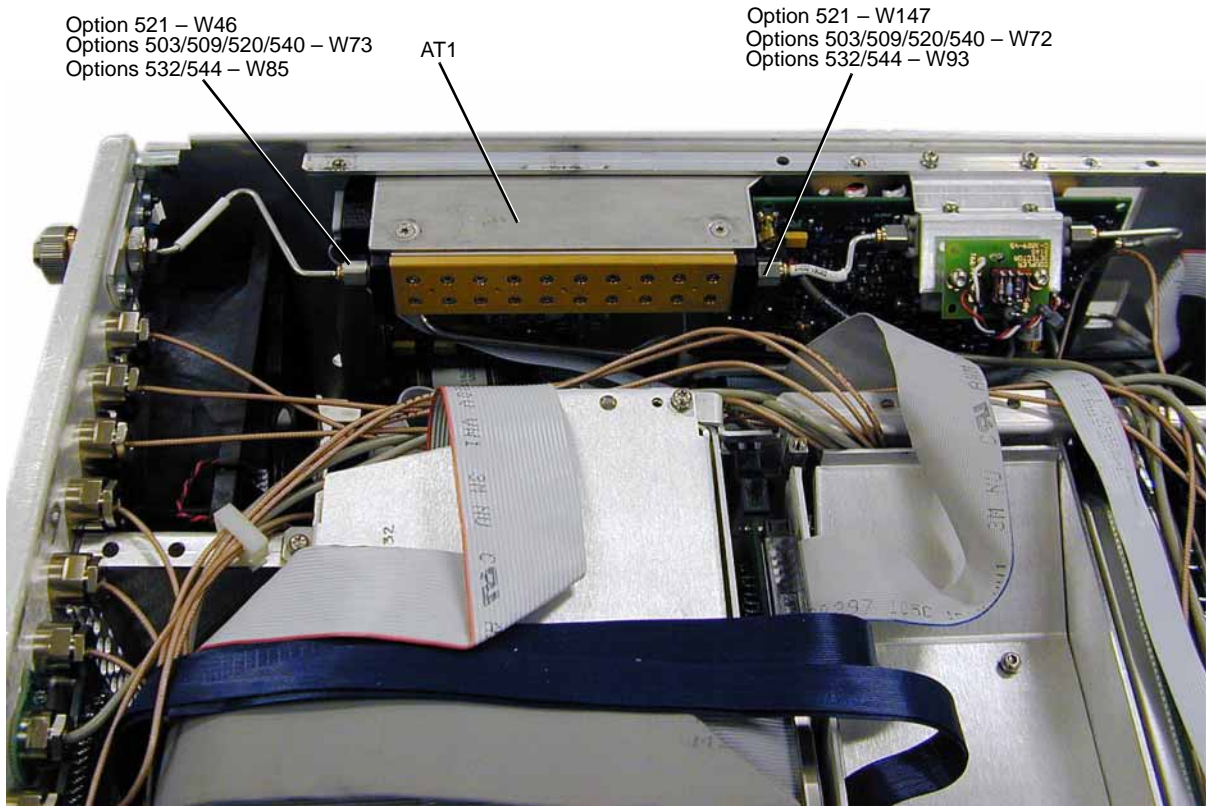

B1 Fan

Tools Required

- T-10 driver
- 5/16" open-ended wrench

Removal Procedure

Refer to **Figure 3-76** for this procedure.

1. Disconnect the power cord.
2. Remove the covers from the signal generator. Refer to “**Outer Instrument Cover**” on page 6 and “**Inner Instrument Cover**” on page 8.
3. Position the signal generator with the rear panel facing you.
4. For Option 1EM signal generators only, use the 5/16" open-ended wrench to disconnect the following RF cable according to the signal generator you have.

Options 520 and 540: Disconnect W73 RF cable from the AT1 115 dB Attenuator and the RF Out.

Options 532 and 544: Disconnect W85 RF cable from the AT1 115 dB Attenuator and the RF Out.

Options 550 and 567: Disconnect W94 RF cable from the AT1 90 dB Attenuator and the RF Out.

5. Using the T-10 driver, remove the four screws (1) that attach the B1 Fan to the rear panel.
6. Disconnect the fan cable (2) from the A31 Motherboard P251.
7. Remove the B1 Fan.

Replacement Procedure

- Reverse the order of the removal procedure.
- Torque all T-10 screws to 9 in-lbs.
- Torque all RF connectors to 8 in-lbs.
- Perform the post-repair adjustments and performance tests that pertain to this removal procedure.

Assembly Replacement
B1 Fan

Figure 3-76

B1 Fan

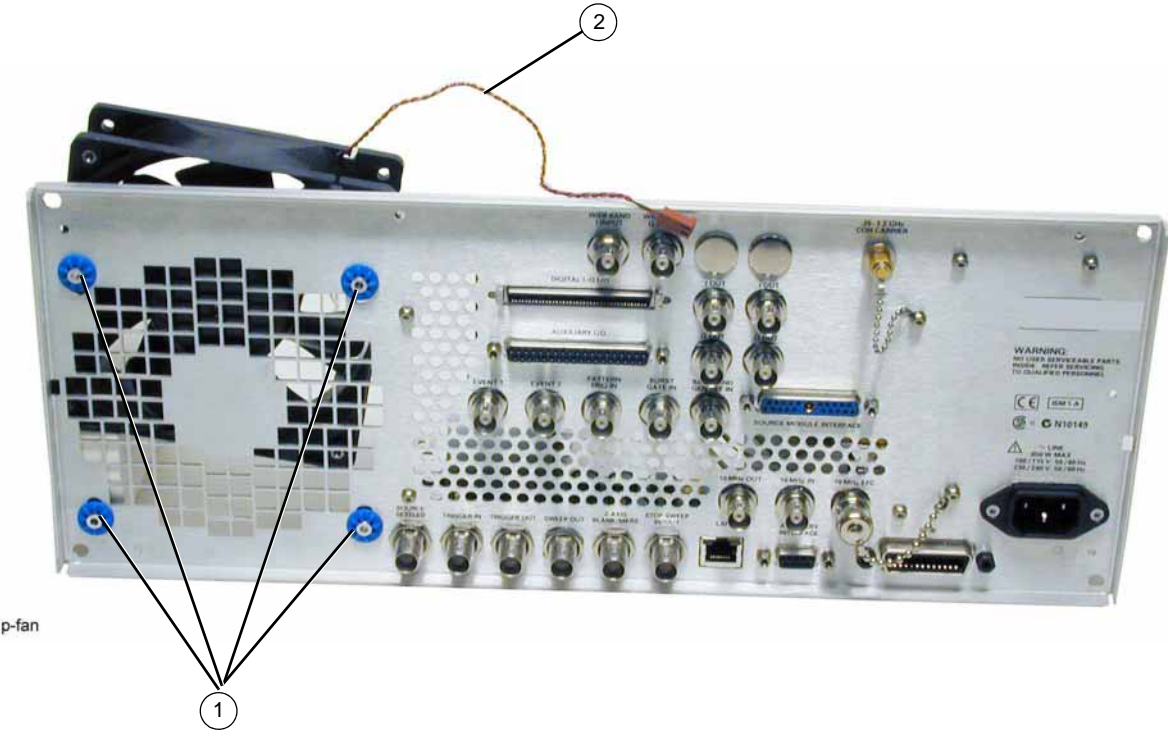

p-fan

4 Post–Repair Procedures

- “Post Repair Adjustments: Assemblies A1–A12 (For Prefixes < xx4928)” on page 2
- “Post Repair Adjustments: Assemblies A13–A26 (For Prefixes < xx4928)” on page 3
- “Post Repair Adjustments: Assemblies A27–A40, AT1, B1, and RF Output Connector (For Prefixes < xx4928)” on page 4
- “Post–Repair Adjustments: Assemblies A1–A11 (For prefixes >= xx4928)” on page 5
- “Post–Repair Adjustments: Assemblies A13–A26 (For prefixes >= xx4928)” on page 6
- “Post–Repair Adjustments: Assemblies A27–A46, AT1, B1, and RF Output Connector (For prefixes >= xx4928)” on page 8
- “Performance Tests: Assemblies A1–A17 (For Prefixes < xx4928)” on page 9
- “Performance Tests: Assemblies A18–A29 (For Prefixes < xx4928)” on page 10
- “Performance Tests: Assemblies A30–A40, AT1, B1, and RF Output Connector (For Prefixes < xx4928)” on page 11
- “Performance Tests: Assemblies A1–A17 (For prefixes >= xx4928)” on page 12
- “Performance Tests: Assemblies A18–A29 (For prefixes >= xx4928)” on page 14
- “Performance Tests: Assemblies A30–A46, AT1, B1, and RF Output Connector (For prefixes >= xx4928)” on page 15
- “CPU Configuration” on page 16

Post-Repair Procedures Matrix

Table 4-1 Post Repair Adjustments: Assemblies A1–A12 (For Prefixes < xx4928)

Adjustments	Replaced Assembly														
	A1 Keyboard	A2 Display	A2DS1 Display Backlight	A3 Power Switch	A4 Inverter	A5 Sampler	A6 Frac-N	A7 Reference (Standard)	A7 Reference (Option UNR/UNX)	A8 Output (Analog)	A8 Output (Digital)	A9 YIG Driver	A10 ALC	A11 Pulse/Analog Mod Gen	A12 Low Band Fast Pulse
The following adjustments are listed in the order that they should be performed for proper calibration.															
ADC Calibration						✓	✓	✓	✓	✓	✓	✓	✓	✓	✓
YIG-Driver Pre-Tune Calibration												✓			
VCO Bias Frac-N Calibration							✓								
Internal Source Calibration														✓	
AM Audio Path Offset Calibration													✓	✓	
KV vs. Frequency Calibration							✓								
Timebase Calibration (instruments with serial prefixes <US4805/MY4805 and non UNR/UNX and/or UNJ Options)								✓							
FM Scale Offset Calibration							✓					✓		✓	
FM Path Offset Calibration							✓					✓		✓	
FM In-band Offset Calibration							✓					✓		✓	
FM Inverting Amplifier Offset Calibration														✓	
FM 1/2 Path Ratio Gain Calibration							✓					✓		✓	
Mod Source Relative Gain Calibration							✓					✓		✓	
FM/PM Out-of-Band Calibration							✓					✓		✓	
FM/PM YO Frequency Compensation Calibration							✓					✓		✓	
DC FM Calibration							✓					✓		✓	
Low Frequency Output Calibration														✓	
External Input Peak Detector Calibration														✓	
Target IQ Power Calibration												✓			
1/f Corner Calibration												✓			
IQ Time Skew RF												✓			
IQ Time Skew Baseband												✓			
ALC Dynamic Calibration										✓	✓		✓		✓
Lowband Digital Prelevel Gain Calibration											✓				
VBLO Mixer Bias Calibration											✓				
LB Digital Gain Calibration											✓				
Gain Adjustment Bypass Calibration (Frequencies ≤3.2 GHz)							✓			✓	✓	✓			
Low Band Power Flatness Calibration										✓	✓		✓		✓
High Band Power Flatness Calibration										✓	✓		✓		✓
High Band IQ Power Floor Calibration											✓				
Low Band IQ Power Floor Calibration															
ALC Modulator Calibration										✓	✓		✓		
Low Band ALC Modulator Calibration											✓				
ALC Mod Bias DAC Sensitivity Calibration											✓		✓		

Table 4-1 Post Repair Adjustments: Assemblies A1–A12 (For Prefixes < xx4928)

Adjustments	Replaced Assembly														
	A1 Keyboard	A2 Display	A2DS1 Display Backlight	A3 Power Switch	A4 Inverter	A5 Sampler	A6 Frac-N	A7 Reference (Standard)	A7 Reference (Option UNR/UNX)	A8 Output (Analog)	A8 Output (Digital)	A9 YIG Driver	A10 ALC	A11 Pulse/Analog Mod Gen	A12 Low Band Fast Pulse
The following adjustments are listed in the order that they should be performed for proper calibration.															
AM Gain Calibration										✓	✓		✓	✓	
IQ Impairment Calibration											✓				
Power Clamp										✓					
Pulse Width Calibration										✓	✓			✓	✓
9V PTAT Abus Calibration													✓		

Table 4-2 Post Repair Adjustments: Assemblies A13–A26 (For Prefixes < xx4928)

Adjustments	Replaced Assembly																
	A13 IQ Multiplexer	A14 Baseband Generator	A17 Baseband Generator Interface	A18 CPU	A19 Power Supply	A20 SMI [Source Module Interface]	A21 Rear Panel	A22 Line Module	A23 Lowband Coupler/Detector	A24 20 GHz Coupler	A24 40 GHz Coupler	A24 67 GHz Coupler	A25 20 GHz Detector	A25 40 GHz Detector	A25 67 GHz Detector	A25B Detector Bias Board	A26 MID
The following adjustments are listed in the order that they should be performed for proper calibration.																	
ADC Calibration	✓	✓		✓													✓
IQ /Gain/Offset/Quadrature Calibration	✓	✓	✓														
Target IQ Power Calibration	✓																
1/f Corner Calibration	✓																
IQ Time Skew RF	✓	✓															
IQ Time Skew Baseband	✓	✓	✓														
ALC Dynamic Calibration									✓	✓	✓	✓	✓	✓	✓	✓	
Lowband Digital Prelevel Gain Calibration	✓																
VBLO Mixer Bias Calibration	✓																
LB Digital Gain Calibration	✓																
Low Band Power Flatness Calibration									✓	✓	✓	✓	✓	✓	✓	✓	
High Band Power Flatness Calibration									✓	✓	✓	✓	✓	✓	✓	✓	
V-Band Power Flatness Calibration												✓				✓	
IQ Power Floor Calibration	✓																
Low Band IQ Power Floor Calibration	✓																
IQ Impairment Calibration	✓	✓	✓														

**Table 4-3 Post Repair Adjustments:
 Assemblies A27–A40, AT1, B1, and RF Output Connector (For Prefixes < xx4928)**

Adjustments	Replaced Assembly															
	A27 40 GHz Doubler	A28 YIG Oscillator	A29 20 GHz Doubler	A30 Mod Filter	A31 Motherboard	A32 10 MHz Crystal Oscillator	A34 Internal Hard Drive	A35 3 – 20 IQ Modulator	A36 Quadrupler	A37 Up Converter	A38 Lowband Switch Filter	A39 Directional Coupler	A40 Flash Drive	AT1 115 dB Attenuator	B1 Fan	RF Output Connector
The following adjustments are listed in the order that they should be performed for proper calibration.																
ADC Calibration	✓	✓	✓	✓				✓	✓	✓	✓					
YIG-Driver Pre-Tune Calibration		✓														
FM Scale Offset Calibration		✓														
FM Path Offset Calibration		✓														
FM In-band Offset Calibration		✓														
FM 1/2 Path Ratio Gain Calibration		✓														
Mod Source Relative Gain Calibration		✓														
FM/PM YO Frequency Compensation Calibration		✓														
DC FM Calibration		✓														
External Input Peak Detector Calibration		✓														
I/Q Modulation Calibration								✓								
High Band ALC Modulator Calibration								✓								
IQ Gain/Offset/Quadrature Calibration								✓								
Target IQ Power Calibration								✓		✓						
1/f Corner Calibration								✓								
IQ Time Skew RF								✓		✓						
IQ Time Skew Baseband								✓		✓						
ALC Dynamic Calibration				✓					✓	✓	✓					
Upconverter Gain Adjustment Calibration										✓						
High Band Power Flatness Calibration				✓					✓	✓				✓		✓
Low Band Power Flatness Calibration				✓					✓	✓				✓		✓
V-Band Power Flatness Calibration				✓					✓	✓				✓		✓
V-Band Low Power Attenuator Accuracy Calibration									✓					✓		
Low Power Attenuator Accuracy Calibration										✓				✓		
Lowband Filter Offset Calibration											✓					
IQ Power Floor Calibration								✓		✓						
Low Band IQ Power Floor Calibration																
ALC Modulator Calibration				✓												
ALC Mod Bias DAC Sensitivity Calibration				✓					✓	✓						
AM Gain Calibration				✓												
IQ Impairment Calibration								✓								
Pulse Width Calibration				✓												
Attenuator Cycle Count Reset (Service Software - Utility)														✓		

Table 4-4 Post-Repair Adjustments: Assemblies A1–A11 (For prefixes >= xx4928)

Adjustments	Replaced Assembly													
	A1 Keyboard	A2 Display	A2DS1 Display Backlight	A3 Power Switch	A4 Inverter	A5 Sampler	A6 Frac-N	A7 Reference (Standard)	A7 Reference (Option UNR/UNX)	A8 Output (Analog)	A8 Output (Digital)	A9 YIG Driver	A10 ALC	A11 Pulse/Analog Mod Gen
The following adjustments are listed in the order that they should be performed for proper calibration.														
ADC Calibration						✓	✓	✓	✓	✓	✓	✓	✓	✓
YIG-Driver Pre-Tune Calibration												✓		
VCO Bias Frac-N Calibration							✓							
Internal Source Cal (E8257D/E8663D with Option UNT)														✓
AM Audio Path Offset Cal (E8257D/E8663D with Option UNT)														✓
KV vs. Frequency Calibration							✓							
FM Scale Offset Calibration (E8257D/E8663D with Option UNT)							✓					✓		✓
FM Path Offset Calibration (E8257D/E8663D with Option UNT)							✓					✓		✓
FM In-band Offset Calibration (E8257D/E8663D with Option UNT)							✓					✓		✓
FM Inverting Amplifier Offset Calibration (E8257D/E8663D with Option UNT)														✓
FM 1/2 Path Ratio Gain Calibration (E8257D/E8663D with Option UNT)							✓					✓		✓
Mod Source Relative Gain Calibration							✓					✓		✓
FM/PM Out-of-Band Calibration							✓					✓		✓
FM/PM YO Frequency Compensation Calibration (E8257D/E8663D with Option UNT and E8257N Only)							✓					✓		✓
DC FM Calibration (E8257D/E8663D with Option UNT)							✓					✓		✓
Low Frequency Output Calibration (E8257D/E8663D with Option UNT)														✓
External Input Peak Detector Calibration (E8257D/E8663D with Option UNT)														✓
High Band ALC Linearity Calibration													✓	
High Band Power Flatness Calibration													✓	
High Band High Power ALC linearity Calibration (E8257D with Option 521 Only)													✓	
High Band ALC Modulator Calibration													✓	
AM Gain Calibration (E8257D/E8663D with Option UNT)													✓	✓
Low Band ALC Linearity Calibration										✓	✓		✓	
Low Band Power Flatness Calibration										✓	✓		✓	
Low Band High Power ALC Linearity Calibration										✓	✓		✓	
User Clamp Calibration (Option 1EU Only)													✓	
Low Band Bypass Gain Calibration							✓			✓	✓	✓	✓	
Power Clamp Calibration										✓	✓		✓	
Low Band Power Maximum Calibration										✓	✓		✓	
Low Band ALC Modulator Prep Calibration										✓	✓		✓	
ALC Modulator Offset DAC Sensitivity Calibration										✓	✓		✓	
Low Band ALC Modulator Calibration										✓	✓		✓	
Low Band Scan Modulator Calibration (E8257D/E8663D with option HSM or 1SM)										✓			✓	

Table 4-4 Post-Repair Adjustments: Assemblies A1–A11 (For prefixes >= xx4928)

Adjustments	Replaced Assembly													
	A1 Keyboard	A2 Display	A2DS1 Display Backlight	A3 Power Switch	A4 Inverter	A5 Sampler	A6 Frac-N	A7 Reference (Standard)	A7 Reference (Option UNR/UNX)	A8 Output (Analog)	A8 Output (Digital)	A9 YIG Driver	A10 ALC	A11 Pulse/Analog Mod Gen
High Band Scan Modulator Calibration (E8257D/E8663D with option HSM or 1SM)													✓	
User Clamp Refinement Calibration (E8257D/E8663D with Option HSM or 1SM and Option 1EU Only)													✓	
Power Clamp Refinement Calibration (E8257D/E8663D with Option HSM or 1SM Only)													✓	
Low Band Power Maximum Refinement Calibration (E8257D/E8663D with Option HSM or 1SM Only)									✓				✓	
Low Band ALC Modulator Refinement Calibration (E8257D/E8663D with Option HSM or 1SM Only)									✓				✓	
V-Band Power Flatness Calibration (E8257D with Option 567 Only)													✓	
V-Band Low Power Attenuator Accuracy (E8257D with Option 567 and 1E1 Only)													✓	
V-Band ALC Modulator Calibration (E8257D with Option 567 Only)													✓	
Ramp Sweep Calibration (E8257D/E8663D with 007 and E8257N Only)									✓				✓	
Pulse Width calibration (E8257D with Option UNU, UNW, UNS, or HNS, and E8663D/E8257N Only)														✓
Low Band Digital Prelevel Calibration										✓				
VBLO Mixer Bias Calibration										✓				
Low Band Digital Gain Calibration										✓				
9V PTAT ABUS Measure Calibration													✓	

Table 4-5 Post-Repair Adjustments: Assemblies A13–A26 (For prefixes >= xx4928)

Adjustments	Replaced Assembly																
	A13 IQ Multiplexer	A14 Baseband Generator	A17 Baseband Generator Interface	A18 CPU	A19 Power Supply	A20 SMI [Source Module Interface]	A21 Rear Panel	A22 Line Module	A23 Lowband Coupler/Detector	A24 20 GHz Coupler	A24 40 GHz Coupler	A24 67 GHz Coupler	A25 20 GHz Detector	A25 40 GHz Detector	A25 67 GHz Detector	A25B Detector Bias Board	A26 MID
ADC Calibration				✓													✓
High Band ALC Linearity Calibration									✓	✓			✓	✓			
High Band Power Flatness Calibration									✓	✓			✓	✓			
High Band High Power ALC linearity Calibration (E8257D with Option 521 Only)									✓	✓			✓	✓			
Low Band ALC Linearity Calibration									✓	✓			✓	✓			
Low Band ALC Linearity Calibration								✓									

Table 4-5 Post-Repair Adjustments: Assemblies A13–A26 (For prefixes >= xx4928)

Adjustments	Replaced Assembly																
	A13 IQ Multiplexer	A14 Baseband Generator	A17 Baseband Generator Interface	A18 CPU	A19 Power Supply	A20 SMI [Source Module Interface]	A21 Rear Panel	A22 Line Module	A23 Lowband Coupler/Detector	A24 20 GHz Coupler	A24 40 GHz Coupler	A24 67 GHz Coupler	A25 20 GHz Detector	A25 40 GHz Detector	A25 67 GHz Detector	A25B Detector Bias Board	A26 MID
The following adjustments are listed in the order that they should be performed for proper calibration.																	
Low Band Power Flatness Calibration									✓								
Low Band High Power ALC Linearity Calibration									✓								
User Clamp Calibration (Option 1EU Only)									✓								
Low Band Power Maximum Calibration									✓								
Low Band ALC Modulator Prep Calibration									✓								
V-Band Power Flatness Calibration (E8257D with Option 567 Only)												✓				✓	
V-Band Low Power Attenuator Accuracy (E8257D with Option 567 and 1E1 Only)																	
V-Band ALC Modulator Calibration (E8257D with Option 567 Only)												✓				✓	
Ramp Sweep Calibration (E8257D/E8663D with 007)										✓	✓		✓	✓			
IQ Gain/Offset/Quadrature Calibration	✓	✓	✓														
Target IQ Power	✓																
1/f Corner	✓																
IQ Time Skew RF	✓	✓															
IQ Time Skew Baseband	✓	✓	✓														
Low Band IQ Power Floor Calibration	✓																
High Band IQ Power Floor Calibration	✓																
Low Band IQ Boost Calibration	✓																
IQ Impairment Calibration	✓	✓	✓														

**Table 4-6 Post-Repair Adjustments:
 Assemblies A27–A46, AT1, B1, and RF Output Connector (For prefixes >= xx4928)**

Adjustments	Replaced Assembly																		
	A27 40 GHz Doubler	A28 YIG Oscillator	A29 20 GHz Doubler	A30 Mod Filter	A31 Motherboard	A32 10 MHz Crystal Oscillator	A34 Internal Hard Drive	A35 3 – 20 IQ Modulator	A36 Quadrupler	A37 Up Converter	A39 Directional Coupler	A40 Flash Drive	A43 LB Amp/Filter	A44 Scan Mod	A45 Frac-N/Offset ^a	A46 Offset Loop ^a	AT1 115 dB Attenuator	B1 Fan	RF Output Connector
The following adjustments are listed in the order that they should be performed for proper calibration.																			
ADC Calibration	✓	✓	✓	✓				✓	✓	✓			✓						
Frac-N Pretune Calibration (Option UNY)															✓	✓			
Offset Loop Pre-tune Calibration (Option UNY)															✓	✓			
YIG-Driver Pre-Tune Calibration		✓													✓	✓			
FM Scale Offset Calibration (E8257D/E8663D with Option UNT)		✓													✓	✓			
FM Path Offset Calibration (E8257D/E8663D with Option UNT)		✓													✓	✓			
FM In-band Offset Calibration (E8257D/E8663D with Option UNT)		✓													✓	✓			
FM In- band DCFM Calibration (E8257D, E8267D, and E8663D Option UNT and UNY Only)															✓	✓			
FM Out-of-Band YO Calibration (E8257D, E8267D, and E8663D Option UNT and UNY Only)															✓	✓			
IQ Modulation Calibration								✓											
IQ Upconverter Gain Calibration										✓									
FM 1/2 Path Ratio Gain Calibration (E8257D/E8663D with Option UNT)		✓																	
Mod Source Relative Gain Calibration		✓																	
FM/PM YO Frequency Compensation Calibration (E8257D/E8663D with Option UNT)		✓																	
DC FM Calibration (E8257D/E8663D with Option UNT)		✓																	
External Input Peak Detector Calibration (E8257D/E8663D with Option UNT)		✓																	
Quadrupler Download (E8257D with Option 550 or 567 or E8257N with Option 550 Only)									✓										
High Band ALC Linearity Calibration														✓					
High Band Power Flatness Calibration			✓						✓								✓		✓
High Band High Power ALC linearity Calibration (E8257D with Option 521 Only)				✓															
High Band ALC Modulator Calibration				✓				✓						✓					
Low Band ALC Linearity Calibration													✓						
Low Band Power Flatness Calibration																	✓		✓
ALC Modulator Offset DAC Sensitivity Calibration													✓						

**Table 4-6 Post-Repair Adjustments:
 Assemblies A27–A46, AT1, B1, and RF Output Connector (For prefixes >= xx4928) (Continued)**

Adjustments	Replaced Assembly																		
	A27 40 GHz Doubler	A28 YIG Oscillator	A29 20 GHz Doubler	A30 Mod Filter	A31 Motherboard	A32 10 MHz Crystal Oscillator	A34 Internal Hard Drive	A35 3 – 20 IQ Modulator	A36 Quadrupler	A37 Up Converter	A39 Directional Coupler	A40 Flash Drive	A43 LB Amp/Filter	A44 Scan Mod	A45 Frac-N/Offset ^a	A46 Offset Loop ^a	AT1 115 dB Attenuator	B1 Fan	RF Output Connector
High Band Scan Modulator Calibration (E8257D/E8663D with option HSM or 1SM)														✓					
V-Band Power Flatness Calibration (E8257D with Option 567 Only)									✓								✓		
V-Band Low Power Attenuator Accuracy (E8257D with Option 567 and 1E1 Only)													✓				✓		
V-Band ALC Modulator Calibration (E8257D with Option 567 Only)				✓															
Low Power Attenuator Accuracy (E8257D/E8663D with Option 1E1 and E8257N Only)												✓					✓		

a. Requires adjustments to pass self test.

Table 4-7 Performance Tests: Assemblies A1–A17 (For Prefixes < xx4928)

Performance Tests	Replaced Assembly																	
	A1 Keyboard	A2 Display	A2DS1 Backlight	A3 Power Switch	A4 Inverter	A5 Sampler	A6 Frac-N	A7 Reference (Standard)	A7 Reference (Option UNR/UNX)	A8 Output (Analog)	A8 Output (Digital)	A9 YIG Driver	A10 ALC	A11 Pulse/Analog Mod Gen	A12 Lowband Fast Pulse	A13 IQ Multiplexer	A14 Baseband Generator	A17 Baseband Generator Interface
Self Tests	✓	✓	✓	✓	✓	✓	✓	✓	✓	✓	✓	✓	✓	✓	✓	✓	✓	✓
Maximum Levelled Output Power							✓			✓	✓		✓					
Power Level Accuracy										✓	✓		✓					
Internal Pulse Modulation Level Accuracy										✓	✓			✓	✓			
Internal Pulse Modulation Rise/Fall Time										✓	✓			✓	✓			
DC FM Carrier Offset							✓							✓				
Internal FM Frequency Response							✓				✓			✓				
External Phase Modulation Frequency Response							✓				✓			✓				
Internal FM Distortion							✓							✓				
Internal Phase Modulation Distortion							✓							✓				
External FM Deviation Accuracy							✓				✓			✓				
Internal Phase Modulation Deviation Accuracy							✓				✓			✓				

Table 4-7 Performance Tests: Assemblies A1–A17 (For Prefixes < xx4928) (Continued)

Performance Tests	Replaced Assembly																	
	A1 Keyboard	A2 Display	A2DS1 Backlight	A3 Power Switch	A4 Inverter	A5 Sampler	A6 Frac-N	A7 Reference (Standard)	A7 Reference (Option UNR/UNX)	A8 Output (Analog)	A8 Output (Digital)	A9 YIG Driver	A10 ALC	A11 Pulse/Analog Mod Gen	A12 Lowband Fast Pulse	A13 IQ Multiplexer	A14 Baseband Generator	A17 Baseband Generator Interface
External Pulse Modulation ON/OFF Ratio										✓	✓			✓	✓			
Harmonic Spurious							✓	✓	✓	✓	✓							
Sub-Harmonic Spurious							✓	✓	✓									
Non-Harmonic Spurious						✓	✓	✓	✓	✓	✓							
Single-Sideband Phase Noise						✓	✓	✓	✓	✓	✓							
EVM and IQ Offset												✓				✓	✓	
External Digital Modulation Level Accuracy Relative to CW												✓				✓	✓	
Swept Frequency Accuracy							✓					✓						
Functional Check (Service Software – Utility)																		
Dual Arb																		✓

Table 4-8 Performance Tests: Assemblies A18–A29 (For Prefixes < xx4928)

Performance Tests	Replaced Assembly																
	A18 CPU or BT1	A19 Power Supply	A20 SMI [Source Module Interface]	A21 Rear Panel Interface	A22 Line Module	A23 Lowband Coupler/Detector	A24 20 GHz Coupler	A24 40 GHz Coupler	A24 67 GHz Coupler	A25 20 GHz Detector	A25 40 GHz Detector	A25 67 GHz Detector	A25B Detector Bias Board	A26 MID [Microcircuit Interface Deck]	A27 40 GHz Doubler	A28 YIG Oscillator	A29 20 GHz Doubler
Self Tests	✓	✓	✓	✓	✓	✓	✓	✓	✓	✓	✓	✓	✓	✓	✓	✓	✓
Maximum Levelled Output Power						✓	✓	✓	✓	✓	✓	✓		✓	✓	✓	✓
Power Level Accuracy						✓	✓	✓	✓	✓	✓	✓	✓	✓	✓		✓
Internal FM Frequency Response																	✓
External Phase Modulation Frequency Response																	✓
External FM Deviation Accuracy																	✓

Table 4-8 Performance Tests: Assemblies A18–A29 (For Prefixes < xx4928) (Continued)

Performance Tests	Replaced Assembly																
	A18 CPU or BT1	A19 Power Supply	A20 SMI [Source Module Interface]	A21 Rear Panel Interface	A22 Line Module	A23 Lowband Coupler/Detector	A24 20 GHz Coupler	A24 40 GHz Coupler	A24 67 GHz Coupler	A25 20 GHz Detector	A25 40 GHz Detector	A25 67 GHz Detector	A25B Detector Bias Board	A26 MID [Microcircuit Interface Deck]	A27 40 GHz Doubler	A28 YIG Oscillator	A29 20 GHz Doubler
The following performance tests are listed in the order that they should be performed to minimize changes in test equipment configurations.																	
Internal Phase Modulation Deviation Accuracy																✓	
Harmonic Spurious														✓	✓	✓	✓
Sub-Harmonic Spurious															✓	✓	✓
Non-Harmonic Spurious		✓															
Single-Sideband Phase Noise																✓	

Table 4-9 Performance Tests: Assemblies A30–A40, AT1, B1, and RF Output Connector (For Prefixes < xx4928)

Performance Tests	Replaced Assembly													
	A30 Mod Filter with High Power	A30 Mod Filter with Standard Power	A31 Motherboard	A32 10 MHz Crystal Oscillator	A34 Internal Hard Drive	A35 3 – 20 IQ Modulator	A36 Quadrupler	A37 Up Converter	A38 Lowband Switch Filter	A39 Directional Coupler	A40 Compact Flash Drive	AT1 115 dB Attenuator	B1 Fan	RF Output Connector
The following performance tests are listed in the order that they should be performed to minimize changes in test equipment configurations.														
Self Tests	✓	✓	✓	✓		✓	✓	✓	✓	✓		✓	✓	✓
Maximum Levelled Output Power	✓	✓				✓	✓	✓	✓			✓		✓
Power Level Accuracy	✓	✓	✓			✓	✓	✓				✓		✓
Internal Pulse Modulation Level Accuracy	✓	✓					✓	✓						
Internal Pulse Modulation Rise/Fall Time	✓	✓					✓	✓						
External Pulse Modulation ON/OFF Ratio	✓	✓					✓	✓						
Harmonic Spurious	✓	✓				✓	✓	✓	✓					
Sub-Harmonic Spurious							✓	✓	✓					
Non-Harmonic Spurious			✓	✓			✓	✓	✓				✓	
Single-Sideband Phase Noise				✓			✓	✓						

Table 4-9 Performance Tests: Assemblies A30–A40, AT1, B1, and RF Output Connector (For Prefixes < xx4928)

Performance Tests	Replaced Assembly													
	A30 Mod Filter with High Power	A30 Mod Filter with Standard Power	A31 Motherboard	A32 10 MHz Crystal Oscillator	A34 Internal Hard Drive	A35 3 – 20 IQ Modulator	A36 Quadrupler	A37 Up Converter	A38 Lowband Switch Filter	A39 Directional Coupler	A40 Compact Flash Drive	AT1 115 dB Attenuator	B1 Fan	RF Output Connector
The following performance tests are listed in the order that they should be performed to minimize changes in test equipment configurations.														
EVM and IQ Offset						✓		✓						
External Digital Modulation Level Accuracy Relative to CW						✓		✓						
Optional Performance Test														
Timebase Aging Rate				✓										

Table 4-10 Performance Tests: Assemblies A1–A17 (For prefixes >= xx4928)

Performance Tests	Replaced Assembly																	
	A1 Keyboard	A2 Display	A2DS1 Backlight	A3 Power Switch	A4 Inverter	A5 Sampler	A6 Frac-N	A7 Reference (Standard)	A7 Reference (Option UNR/UNX)	A8 Output (Analog)	A8 Output (Digital)	A9 YIG Driver	A10 ALC	A11 Pulse/Analog Mod Gen	A12 Lowband Fast Pulse	A13 IQ Multiplexer	A14 Baseband Generator	A17 Baseband Generator Interface
The following performance tests are listed in the order that they should be performed to minimize changes in test equipment configurations.																		
Self Check Test	✓	✓	✓	✓	✓	✓	✓	✓	✓	✓	✓	✓	✓	✓	✓	✓	✓	✓
Maximum Leveled Output Power							✓			✓	✓		✓					
Maximum Leveled Output Power - Digital Mode (E8267D Option HBL Only)										✓								
Maximum Leveled Output Power - Wide IQ/FM Mode (E8267D Option H18 Only)										✓								
Power Level Accuracy										✓	✓		✓					
Internal Pulse Modulation Level Accuracy (E8257D/E8267D Option UNU, UNW, UNS, or HNS, and E8663D Only)										✓	✓			✓	✓			
Internal Pulse Modulation Rise/Fall Time (E8257D/E8267D Option UNW, UNS, or HNS, E8663D Option UNW)										✓				✓	✓			
DC FM Carrier Offset (E8257D/E8267D/E8663D Option UNT)							✓							✓				
Internal FM Frequency Response (E8257D/E8267D/E8663D Option UNT Only)							✓				✓		✓					

Table 4-10 Performance Tests: Assemblies A1–A17 (For prefixes >= xx4928) (Continued)

Performance Tests	Replaced Assembly																	
	A1 Keyboard	A2 Display	A2DS1 Backlight	A3 Power Switch	A4 Inverter	A5 Sampler	A6 Frac-N	A7 Reference (Standard)	A7 Reference (Option UNR/UNX)	A8 Output (Analog)	A8 Output (Digital)	A9 YIG Driver	A10 ALC	A11 Pulse/Analog Mod Gen	A12 Lowband Fast Pulse	A13 IQ Multiplexer	A14 Baseband Generator	A17 Baseband Generator Interface
Internal Phase Modulation Deviation Accuracy (E8257D/E8267D/E8663D Option UNT)						✓						✓		✓				
Internal FM Distortion (E8257D/E8267D/E8663D Option UNT)						✓								✓				
Internal Phase Modulation Distortion (E8257D/E8267D/E8663D Option UNT)						✓								✓				
Harmonic Spurious						✓	✓	✓	✓	✓								
Sub-Harmonic Spurious						✓	✓	✓										
Non-Harmonic Spurious					✓	✓	✓	✓	✓	✓								
External FM Deviation Accuracy (E8257D/E8267D/E8663D Option UNT)						✓						✓		✓				
External Phase Modulation Frequency Response (E8257D/E8267D/E8663D Option UNT without UNY)						✓						✓		✓				
External Pulse Modulation On/Off Ratio (E8257D/E8267D Option UNU with serial prefix < 4928, UNW, UNS, or HNS, E8663D Option UNW)									✓	✓				✓	✓			
Single-Sideband Phase Noise (Option UNX or UNY test procedure)						✓	✓	✓	✓	✓	✓	✓						
Single-Sideband Phase Noise (Non-Option UNX or UNY test procedure)						✓	✓	✓	✓	✓	✓	✓						
Residual Phase Noise (E8257D/E8267D/E8663D Option UNX or UNY and without H5Y Only) (Manual Performance Test)						✓	✓	✓	✓	✓	✓	✓						
Internal EVM Digital Modulation Quality (E8267D Option 601 or 602 Only)											✓					✓	✓	
Digital Modulation Power Relative to CW (E8267D Only)											✓					✓	✓	
Swept Frequency Accuracy (E8257D/E8267D/E8663D Option 007)						✓						✓						

Table 4-11 Performance Tests: Assemblies A18–A29 (For prefixes >= xx4928)

Performance Tests	Replaced Assembly																
	A18 CPU or BT1	A19 Power Supply	A20 SMI [Source Module Interface]	A21 Rear Panel Interface	A22 Line Module	A23 Lowband Coupler/Detector	A24 20 GHz Coupler	A24 40 GHz Coupler	A24 67 GHz Coupler	A25 20 GHz Detector	A25 40 GHz Detector	A25 67 GHz Detector	A25B Detector Bias Board	A26 MID [Microcircuit Interface Deck]	A27 40 GHz Doubler	A28 YIG Oscillator	A29 20 GHz Doubler
The following performance tests are listed in the order that they should be performed to minimize changes in test equipment configurations.																	
Self Check Test	✓	✓	✓	✓	✓	✓	✓	✓	✓	✓	✓	✓	✓	✓	✓	✓	✓
Maximum Levelled Output Power						✓	✓	✓	✓	✓	✓	✓		✓	✓	✓	✓
Power Level Accuracy						✓	✓	✓	✓	✓	✓	✓	✓	✓	✓		✓
Internal FM Frequency Response (E8257D/E8267D/E8663D Option UNT Only)																✓	
Internal Phase Modulation Deviation Accuracy (E8257D/E8267D/E8663D Option UNT)																✓	
Harmonic Spurious														✓	✓	✓	✓
Sub-Harmonic Spurious															✓	✓	✓
Non-Harmonic Spurious		✓															
External FM Deviation Accuracy (E8257D/E8267D/E8663D Option UNT)																✓	
External Phase Modulation Frequency Response (E8257D/E8267D/E8663D Option UNT without UNY)																✓	
Single-Sideband Phase Noise (Option UNX or UNY test procedure)																✓	
Single-Sideband Phase Noise (Non-Option UNX or UNY test procedure)																✓	
Residual Phase Noise (E8257D/E8267D/E8663D Option UNX or UNY and without H5Y Only) (Manual Performance Test)																✓	

Table 4-12 Performance Tests: Assemblies A30–A46, AT1, B1, and RF Output Connector (For prefixes >= xx4928)

Performance Tests	Replaced Assembly																	
	A30 Mod Filter with High Power	A30 Mod Filter with Standard Power	A31 Motherboard	A32 10 MHz Crystal Oscillator	A34 Internal Hard Drive	A35 3 – 20 IQ Modulator	A36 Quadrupler	A37 Up Converter	A38 Lowband Switch Filter	A39 Directional Coupler	A40 Compact Flash Drive	A43 LB Amp/Filter	A44 Scan Mod	A45 Frac-N/Offset	A46 Offset Loop	AT1 115 dB Attenuator	B1 Fan	RF Output Connector
The following performance tests are listed in the order that they should be performed to minimize changes in test equipment configurations.																		
Self Check Test	✓	✓	✓	✓		✓	✓	✓	✓	✓		✓	✓			✓	✓	✓
Maximum Leveled Output Power	✓	✓				✓	✓	✓	✓			✓	✓			✓		✓
Maximum Leveled Output Power - Digital Mode (E8267D Option HBL Only)						✓		✓										
Maximum Leveled Output Power - Wide IQ/FM Mode (E8267D Option H18 Only)						✓		✓										
Power Level Accuracy	✓	✓	✓			✓	✓	✓					✓			✓		✓
Internal Pulse Modulation Level Accuracy (E8257D/E8267D Option UNU, UNW, UNS, or HNS, and E8663D Only)	✓	✓					✓	✓										
Internal Pulse Modulation Rise/Fall Time (E8257D/E8267D Option UNW, UNS, or HNS, E8663D Option UNW)	✓	✓					✓	✓										
DC FM Carrier Offset (E8257D/E8267D/E8663D Option UNT)														✓	✓			
Harmonic Spurious	✓	✓				✓	✓	✓	✓			✓		✓	✓			
Sub-Harmonic Spurious							✓	✓	✓			✓		✓	✓			
Non-Harmonic Spurious			✓	✓			✓	✓	✓			✓		✓	✓		✓	
Single-Sideband Phase Noise (Option UNX or UNY test procedure)				✓			✓	✓						✓	✓			
Single-Sideband Phase Noise (Non-Option UNX or UNY test procedure)				✓			✓	✓										
Residual Phase Noise (E8257D/E8267D/E8663D Option UNX or UNY and without H5Y Only) (Manual Performance Test)				✓			✓	✓						✓	✓			
Internal EVM Digital Modulation Quality (E8267D Option 601 or 602 Only)						✓		✓										
Digital Modulation Power Relative to CW (E8267D Only)						✓		✓										

CPU Configuration

1. Power on the signal generator.
 - If the firmware loaded on the CPU matches the instrument model, go to **Step 6**.
 - If the firmware is for a different instrument model, the instrument should still turn-on, but the firmware needs to be changed. To change the firmware continue with **Step 2**.
2. Set the IP address:

Press **Utility > GPIB/RS-232 LAN > LAN Setup > IP Address**.

 - a. Set the LAN configuration to DHCP.
 - b. Cycle the signal generator power.
3. Set the remote language:
 - Press **Return > Remote Language > SCPI**.
4. Check that the instrument identification number (IDN) is correct by executing the command, *IDN?.
 - If the IDN is not correct, change the IDN by executing the following command:

```
:SYST:IDN "Keysight Technologies, <Model Number>, <Serial Number>, <Firmware Revision>"
```

NOTE

When executing the command, ensure that the firmware revision parameter matches the signal generator model. For example, E8257D and E8267D use firmware revisions that start with C.04.xx.

5. Download the new firmware:
 - a. Go to www.keysight.com/find/psg/upgradeassistant
 - b. Download (save to disk) both the PSG-ESG Upgrade Assistant software and the latest PSG firmware.
 - c. Go to the folder where the files were saved and click on each program.

The programs open the files and saves the routines to a folder.
 - d. Click **Yes** when asked to create a short-cut on your desktop.
6. Install the new firmware:
 - a. Open the PSG-ESG Upgrade Assistant.
 - b. Enter the following information:

- Connection Type
 - LAN Setup (IP or GPIB address)
 - Firmware Release—Use the browser to locate and select the firmware revision to install. The file has a .esg extension (filename.esg) and are model number specific.
 - Special Cases
 - Select **Added New Hardware**.
 - If you previously attempted to install new firmware and it failed, also select **Recover Failed Upgrade**.
- c. Click **Next**>.
- d. If the firmware you are downloading is older than the firmware currently installed in the instrument, select **Allow Old Revisions**.
- e. Click **Yes** when the “Warning Allow Old Firmware Revision” message appears and follow the instructions displayed on the PC.
7. Restore the backed up calibration data to the CPU, press **Utility** > **Instrument Adjustments** > **Service Adjustments** > **Restore System Files**.
8. Cycle the instrument power.
9. Verify the instrument model number is correct, press **Utility** > **Instrument Info/Help** > **Diagnostic Info**.
- If the model number is not correct, execute the following command:
:DIAG:FILE:REST
 - If the model number is correct, proceed to the next step.
10. Reset the IDN to the default IDN:
- a. Execute the following command:
:SYST:IDN ""
- b. Check the IDN to ensure it has changed by executing the following command:
*IDN?
11. Check the license keys:
- If the license keys were retrievable from the CPU, go to **Step 12**.
 - If the license key(s) was not retrievable from the replaced CPU, attempt to obtain them from the GSDC website:
 - a. Access the GSDC website:
<http://pamirs.cos.keysight.com/license/>
Their website provides a guest login for searching the data base.

- b.** Use the guest login and search their data base.
- If the license key(s) for your specific instrument is not available from the GSDC website, send a message to the PSG,Sources email node requesting the license keys along with the following information:
 - Instrument model number
 - Serial number
 - Host ID
 - A list of the options

The request will be researched, and if the database indicates that the list of options were installed in the instrument, license keys will be sent. If the database does not show that an option(s) was installed, no license key will be sent for that option. License keys will only be provided for verified options.

12.Install the license keys:

- a.** Press **Utility > Instrument Adjustments > Instrument Options > Software Options.**
- b.** Using the RPG knob, highlight the desired option.
- c.** Press **Modify License Key.**
- d.** Using the numeric key pad and the softkeys, enter the license key.

When the signal generator accepts the license key, a check mark appears next to the license

- e.** After entering all the required license keys, press **Proceed With Reconfiguration.**

If a license key does not turn an option on, proceed to **Step 11** and perform the step as if the license keys had not been retrievable from the CPU.

5 Safety and Regulatory

This chapter provides information on the following:

- “General Safety Considerations” on page 2
- “Lithium Battery Disposal” on page 4
- “Assistance” on page 4
- “Certification” on page 4

The following safety notes are used throughout this manual. Familiarize yourself with each of the notes and its meaning before operating this instrument.

CAUTION

Caution denotes a hazard. It calls attention to a procedure that, if not correctly performed or adhered to, would result in damage to or destruction of the product. Do not proceed beyond a caution sign until the indicated conditions are fully understood and met.

WARNING

Warning denotes a hazard. It calls attention to a procedure which, if not correctly performed or adhered to, could result in injury or loss of life. Do not proceed beyond a warning note until the indicated conditions are fully understood and met.

General Safety Considerations

The following safety notes apply specifically to signal generators. These notes also appear in other chapters of this service guide as required.

WARNING These servicing instructions are for use by qualified personal only. To avoid electrical shock, do not perform any servicing unless you are qualified to do so.

WARNING The opening of covers or removal of parts is likely to expose dangerous voltages. Disconnect the product from all voltage sources before starting to open.

WARNING The detachable power cord is the instrument disconnecting device. It disconnects the mains circuits from the mains supply before other parts of the instrument. The front panel switch is only a standby switch and is not a LINE switch (disconnecting device).

WARNING The power cord is connected to internal capacitors that may remain live for 5 seconds after disconnecting the plug from its power supply.

WARNING This is a Safety Class 1 Product (provided with a protective earthing ground incorporated in the power cord). The mains plug shall only be inserted in a socket outlet provided with a protective earth contact. Any interruption of the protective conductor inside or outside of the product is likely to make the product dangerous. Intentional interruption is prohibited.

WARNING Replace battery only with the same or equivalent type recommended. Discard used batteries according to manufacturer's instructions.

WARNING

If this product is not used as specified, the protection provided by the equipment could be impaired. This product must be used in a normal condition (in which all means for protection are intact) only.

CAUTION

Many of the assemblies in this instrument are very susceptible to damage from electrostatic discharge (ESD). Perform service procedures only at a static-safe workstation and wear a grounding strap.

Lithium Battery Disposal

When the battery on the A14 CPU is exhausted and/or ready for disposal, dispose of it according to your country's requirements. You can return the battery to your nearest Keysight Technologies Sales and Service office for disposal, if required.

Figure 5-1

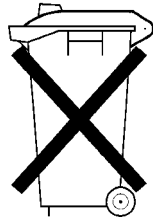

**DO NOT THROW BATTERIES AWAY BUT
COLLECT AS SMALL CHEMICAL WASTE.**

sk780a

Assistance

Product maintenance agreements and other customer assistance agreements are available for Keysight Technologies products. For any assistance, contact your nearest Keysight Technologies sales and service office (see **“Keysight Sales and Service Offices”** on page 1-169).

Certification

Keysight Technologies Company certifies that this product met its published specifications at the time of shipment from the factory. Keysight Technologies further certifies that its calibration measurements are traceable to the United States National Institute of Standards and Technology, to the extent allowed by the Institute's calibration facility, and to the calibration facilities of other International Standards Organization members.

Index

Numerics

10 dB PAD, replacement, 106

10 MHz crystal oscillator,
replacement, 102

115 dB attenuator,
replacement, 141, 145

20 GHz

doubler, replacement, 91, 133

highband coupler,
replacement, 60

highband detector,
replacement, 71

3-20 GHz I/Q Modulator,
replacement, 117, 119

40 GHz

doubler, replacement, 85, 87

highband coupler,
replacement, 65

highband detector,
replacement, 74

50 GHz

highband coupler,
replacement, 67

highband detector,
replacement, 76

6 dB PAD, replacement, 104

67 GHz

highband coupler,
replacement, 69

highband detector,
replacement, 78

90 dB attenuator,

replacement, 139, 143

A

A5 Sampler

description, 133

self-test, 42

A6 Frac-N

description, 133, 140

self-test, 51, 54

A7 Reference

description, 134

self-test, 44

self-test (UNR/UNX), 58

A8 Output

description, 141

self-test, 45, 79, 84, 86

A9 YIG Driver

description, 135

self-test, 48

A10 ALC

description, 145

self-test, 55

A11 Analog/Pulse Modulation Generator

description, 146

self-test, 73

A12 Fast Pulse Modulator,

description, 141

A13 IQ Multiplexer,

self-test, 39

A14 Baseband Generator

description, 148

self-test, 76

A18 CPU

description, 118

self-test, 60

A19 Power Supply,

description, 118

A23 Lowband

Coupler/Detector,

description, 142

A24 Highband Coupler,

description, 142

A25 Highband Detector,

description, 142

A26 MID, self-test

E8257D, 61

E8267D, 67

A27 40 GHz Doubler,

description, 142

A28 YIG Oscillator,

description, 136

A29 20 GHz Doubler,

description, 136, 142

A30 Modulation Filter,

description, 143

A35 3-20 GHz I/Q Modulator,
description, 143

A36 Quadraplier,
description, 144

A37 44GHz Upconverter,
description, 144

A38 Lowband Filter

description, 136

self-test, 81, 82

accessories

test cable, 67

ADC adjustment failures, 103

adjustment problems, 100

adjustments

required after repair, 1

ALC loop, description, 145

ALC, replacement, 31

ALC, troubleshooting, 106

antistatic materials, 2, 68

assemblies list, 4

assembly replacement

A1 Keyboard, 14

A2 Display, 17

A2DS1 Display Backlight, 20

A3 Power Switch, 22

A4 Inverter, 25

A5 Sampler, 27

A6 Frac-N, 27

A7 Reference, 27

A8 Output, 27

A9 YIG driver, 29

A10 ALC, 31

A11 Pulse/Analog

Modulation Generator, 33

A12 Pulse Modulator

Board, 35

A13 I/Q MUX, 37, 39

A14 Baseband Generator, 41

A17 Baseband Generator

Interface, 43

A18 CPU, 45

A18BT1 Battery, 47

A19 Power Supply, 49

A20 SMI (Source Module

Interface), 52

- A21 Rear Panel Interface, 54
- A22 Line Module, 56
- A23 Lowband Coupler/Detector, 58
- A24 20 GHz Highband Coupler, 60
- A24 40 GHz Highband Coupler, 65
- A24 50 GHz Highband Coupler, 67
- A24 67 GHz Highband Coupler, 69
- A25 20 GHz Highband Detector, 71
- A25 40 GHz Highband Detector, 74
- A25 50 GHz Highband Detector, 76
- A25 67 GHz Highband Detector, 78
- A25B Highband Detector Bias Board, 80
- A26 Microcircuit Interface Deck (MID), 82
- A27 40 GHz Doubler, 85, 87
- A28 YIG Oscillator, 89
- A29 20 GHz Doubler, 91, 133
- A30 Modulator Filter, 93
- A31 Motherboard, 96, 99
- A32 10 MHz Crystal Oscillator, 102
- A33 10 dB PAD, 106
- A33 6 dB PAD, 104
- A34 Internal Hard Drive, 115
- A35 3–20 GHz I/Q Modulator, 117, 119
- A36 Quadraplier, 121
- A37 Upconverter, 123
- A38 Lowband Switch Filter, 125, 135, 137
- A39 Directional Sweep Coupler, 127
- A40 Flash Drive, 129
- A41 Flash Drive Door, 131
- AT1 115 dB Attenuator, 141, 145
- AT1 90 dB Attenuator, 139, 143
- B1 Fan, 147
- front panel, 10
- instrument cover, inner, 8
- instrument cover, outer, 6
- preparation, 1
- rear panel, 108, 111
- assembly-level troubleshooting, 14
- AT1 Attenuator, troubleshooting, 109
- attenuator
 - 115 dB, replacement, 141, 145
 - 90 dB, replacement, 139, 143
- B
- backup data, CPU, 8
- baseband generator interface, replacement, 43
- baseband generator, replacement, 41
- battery disposal, 4
- battery, replacement, 47
- block descriptions
 - overall, 118
 - reference/synthesis loop, 131
 - RF path loop, 139
- block diagrams
 - overall
 - E8257D, 127
 - E8267D, 129
 - reference/synthesis loop, 137
 - RF path block diagram
 - E8257D, 151, 153
 - E8267D, 159, 161, 163
- C
- cables, 22
- certification, 4
- components, safe handling, 2
- coupler
 - 20 GHz highband, replacement, 60
 - 40 GHz highband, replacement, 65
 - 50 GHz highband, replacement, 67
 - 67 GHz highband, replacement, 69
 - lowband, replacement, 58
- CPU
 - configuration, 16
 - data backup, 8
 - replacement, 45
 - troubleshooting, 6
- crystal oscillator, 10 MHz, replacement, 102
- CW mode, description, 131
- D
- data backup, CPU, 8
- detector
 - 20 GHz highband, replacement, 71
 - 40 GHz highband, replacement, 74
 - 50 GHz highband, replacement, 76
 - 67 GHz highband, replacement, 78
 - highband bias board, replacement, 80
 - lowband, replacement, 58
- device gains and losses, 149
- digital modulation, description, 147
- directional sweep coupler, replacement, 127
- display backlight, replacement, 20
- display, replacement, 17
- documentation, xiii
- driver, YIG, 29
- E
- electrostatic discharge
 - general information, 2
 - supplies, 68
- ESD, 2
- F
- fan, replacement, 147
- flash drive door, replacement, 131
- flash drive, replacement, 129
- frac-n, replacement, 27
- frequency generation, description, 120
- front panel
 - replacement, 10
 - subassemblies replacement
 - display, 10
 - inverter, 26

G

gains, device, 149
 getting started, 4
 guides, xiii

H

hardware, 40
 hardware list, 4
 harmonic spurs,
 troubleshooting, 111
 harmonics, specifications, 111
 highband detector bias board,
 replacement, 80

I

I/O interface, description, 119
 I/Q MUX, replacement, 37, 39
 I/Q signals, 144
 installation guide, xiii
 instrument cover
 replacement, 6, 8
 internal hard drive,
 replacement, 115
 inverter, replacement, 25

K

keyboard, replacement, 14

L

line module, replacement, 56
 lists
 assemblies and hardware
 options, 4
 cables, 22
 hardware, 40
 replaceable assemblies, 2
 lithium battery disposal, 4
 lithium battery,
 replacement, 47
 losses, device, 149
 lowband coupler/detector,
 replacement, 58
 lowband switch filter,
 replacement, 125, 135, 137

M

microcircuit interface deck
 (MID), replacement, 82
 mixing products, 144
 modulator filter,
 replacement, 93
 motherboard
 connector locations
 E8257D, 30
 E8267D, 31
 LED locations
 E8257D, 34
 E8267D, 35
 test points, 21
 motherboard, replacement, 96,
 99

N

non-harmonic spurs,
 troubleshooting, 116

O

option 015, 144
 Option UNR/UNX,
 troubleshooting, 117
 options, descriptions, 2
 oscillator
 10 MHz crystal, 102
 YIG, 89
 output, replacement, 27
 overcurrent, 36
 overvoltage, 36

P

performance test failures,
 troubleshooting, 104
 performance tests, required
 after repair, 1
 phase noise,
 troubleshooting, 117
 post-repair procedures, 1
 power
 maximum leveled, 93, 94
 RF levels,
 troubleshooting, 106
 power supply
 dc voltage specifications, 32
 motherboard LED locations

E8257D, 34

E8267D, 35

troubleshooting, 21
 power supply, replacement, 49
 power switch, replacement, 22
 programming guide, xiii
 PSG, Option UNY block
 diagram
 E8257D, 157
 PSG, overall block
 description, 118
 PSG, overall block diagram
 E8257D, 127
 E8267D, 129
 PSG, reference/synthesis loop
 block diagram, 137
 PSG, reference/synthesis loop
 description, 131
 PSG, RF path block diagram
 E8257D, 151, 153
 E8267D, 159, 161, 163
 PSG, RF path description, 139
 PSG, RF path block diagram
 E8257D, low band RF
 path, 155
 pulse modulation,
 troubleshooting, 108
 pulse modulator board,
 replacement, 35
 pulse/analog modulation
 generator, replacement, 33

Q

quadrupler, replacement, 121

R

ramp sweep, description, 132
 rear panel, replacement, 108,
 111
 rear-panel interface,
 replacement, 54
 reference, replacement, 27
 reference/synthesis loop,
 description, 131
 references, xiii
 repair
 adjustments required, 1
 performance tests required, 1
 repair, troubleshooting, 1
 replaceable parts

- assemblies, 2
 - hardware, 40
 - ordering information, 1
- RF path
 - description, 139
 - troubleshooting, 106
- RF power levels,
 - troubleshooting, 106
- S
- safety, general
 - considerations, 2
- sampler, replacement, 27
- SCPI reference, xiii
- self-tests
 - 2xx, 42
 - 3xx, 44
 - 4xx, 45
 - 6xx, 48
 - 7xx, 51, 54
 - 9xx, 55
 - 10xx, 58
 - 11xx, 60
 - 12xx, 61, 67
 - 13xx, 73
 - 14xx, 76
 - 1xx, 39
 - 22xx, 79, 84, 86
 - 24xx, 81, 82
 - failure table, 9
 - overview, 165
 - running, 4
- Service
 - Keysight sales and service offices, 169
- service
 - guide, xiii
 - packaging signal generator, 169
- signal generator
 - overall block diagram
 - E8257D, 127
 - E8267D, 129
 - overall description, 118
 - reference/synthesis loop
 - block diagram, 137
 - description, 131
 - RF path block diagram
 - E8257D, 151, 153
 - E8267D, 159, 161, 163
 - RF path, description, 139
 - SMI, replacement, 52
 - source module interface,
 - replacement, 52
 - specifications
 - dc voltages, 32
 - harmonics, 111
 - spurious harmonic emissions,
 - troubleshooting, 111
 - spurious non-harmonic emissions,
 - troubleshooting, 116
 - sum and difference, 144
- T
- thermal shutdown, 37
- troubleshooting
 - ADC adjustment failures, 103
 - adjustment problems, 100
 - ALC, 106
 - AT1 Attenuator, 109
 - chapter TOC, 1
 - CPU turn-on test, 6
 - dc voltages, 21
 - front-panel display, 14
 - motherboard test points, 21
 - Option UNR/UNX phase
 - noise, 117
 - performance test failures, 104
 - power supply, 21
 - pulse modulation, 108
 - RF path, 106
 - RF power levels, 106
 - self-test failure table, 9
 - spurious harmonic emissions, 111
 - spurious non-harmonic emissions, 116
 - unlevels, 92
 - unlocks, 88
 - where to begin, 4
- U
- unlevels, troubleshooting, 92
- unlocks, troubleshooting, 88
- upconverter, replacement, 123
- user
 - documentation, xiii
- V
- voltages, supply
 - A5 Sampler, 42
 - A6 Frac-N, 51, 54
 - A7 Reference
 - Option UNR/UNX, 58
 - standard, 44
 - A8 Output, 45, 79, 84, 86
 - A9 YIG Driver, 48
 - A10 ALC, 55
 - A11 Analog/Pulse
 - Modulation Generator, 73
 - A13 IQ Multiplexer, 39
 - A14 Baseband Generator, 76
 - A18 CPU, 60
 - A26 MID (E8257D), 61
 - A26 MID (E8267D), 67
 - A38 Lowband Filter, 81, 82
- W
- wideband IQ, 144
- Y
- YIG driver, replacement, 29
- YIG oscillator, replacement, 89