

Agilent 4352B VCO/PLL Signal Analyzer

Service Manual

SERIAL NUMBERS

This manual applies directly to instruments with serial number prefix JP1KE00196 or above. For additional important information about serial numbers, read “Serial Number” in Appendix A of this Manual.



Agilent Part No. 04352-90141
Printed in JAPAN June 2000

Second Edition

COPYRIGHT AND DISCLAIMER NOTICE

Copyright – Agilent Technologies, Inc. Reproduced with the permission of Agilent Technologies Inc. Agilent Technologies, Inc. makes no warranty of any kind with regard to this material including, but not limited to, the implied warranties of merchantability and fitness for a particular purpose. Agilent Technologies, Inc. is not liable for errors contained herein or for incidental or consequential damages in connection with the furnishing, performance, or use of this material or data.

Errata

Title & Document Type: 4352B VOC/PLL Signal Analyzer Service Manual

Manual Part Number: 04352-90141

Revision Date: June 2000

HP References in this Manual

This manual may contain references to HP or Hewlett-Packard. Please note that Hewlett-Packard's former test and measurement, semiconductor products and chemical analysis businesses are now part of Agilent Technologies. We have made no changes to this manual copy. The HP XXXX referred to in this document is now the Agilent XXXX. For example, model number HP8648A is now model number Agilent 8648A.

About this Manual

We've added this manual to the Agilent website in an effort to help you support your product. This manual provides the best information we could find. It may be incomplete or contain dated information, and the scan quality may not be ideal. If we find a better copy in the future, we will add it to the Agilent website.

Support for Your Product

Agilent no longer sells or supports this product. You will find any other available product information on the Agilent Test & Measurement website:

www.tm.agilent.com

Search for the model number of this product, and the resulting product page will guide you to any available information. Our service centers may be able to perform calibration if no repair parts are needed, but no other support from Agilent is available

Notice

The information contained in this document is subject to change without notice.

This document contains proprietary information that is protected by copyright. All rights are reserved. No part of this document may be photocopied, reproduced, or translated to another language without the prior written consent of the Agilent Technologies .

Agilent Technologies Japan, Ltd.
Component Test PGU-Kobe
1-3-2, Murotani, Nishi-ku, Kobe-shi,
Hyogo, 651-2241 Japan

MS-DOS[®] is a U.S. registered trademark of Microsoft Corporation.

Printing History

December 1997 First Edition (part number: 04352-90141)
June 2000 Second Edition (part number: 04352-90141)

Safety Summary

The following general safety precautions must be observed during all phases of operation, service, and repair of this instrument. Failure to comply with these precautions or with specific **WARNINGS** elsewhere in this manual may impair the protection provided by the equipment. In addition, it violates safety standards of design, manufacture, and intended use of the instrument.

The Agilent Technologies assumes no liability for the customer's failure to comply with these requirements.

Note

The 4352B complies with INSTALLATION CATEGORY II and POLLUTION DEGREE 2 in IEC1010-1. The 4352B is an INDOOR USE product.



Ground The Instrument

To avoid electric shock hazard, the instrument chassis and cabinet must be connected to a safety earth ground using the supplied power cable with earth blade.

DO NOT Operate In An Explosive Atmosphere

Do not operate the instrument in the presence of flammable gasses or fumes. Operation of any electrical instrument in such an environment constitutes a safety hazard.

Keep Away From Live Circuits

Operating personnel must not remove instrument covers. Component replacement and internal adjustments must be made by qualified maintenance personnel. Do not replace components with the power cable connected. Under certain conditions, dangerous voltages may exist even with the power cable removed. To avoid injuries, always disconnect power and discharge circuits before touching them.

DO NOT Service Or Adjust Alone

Do not attempt internal service or adjustment unless another person, capable of rendering first aid and resuscitation, is present.

DO NOT Substitute Parts Or Modify Instrument

Because of the danger of introducing additional hazards, do not install substitute parts or perform unauthorized modifications to the instrument. Return the instrument to a Agilent Technologies Sales and Service Office for service and repair to ensure the safety features are maintained.

Dangerous Procedure Warnings



Warnings, such as the example below, precede potentially dangerous procedures throughout this manual. Instructions contained in the warnings must be followed.

Warning

Dangerous voltages, capable of causing death, are present in this instrument. Use extreme caution when handling, testing, and adjusting this instrument.



Typeface Conventions

Bold	Boldface type is used when a term is defined. For example: icons are symbols.
<i>Italics</i>	Italic type is used for emphasis and for titles of manuals and other publications. Italic type is also used for keyboard entries when a name or a variable must be typed in place of the words in italics. For example: copy <i>filename</i> means to type the word <code>copy</code> , to type a space, and then to type the name of a file such as <code>file1</code> .
Computer	Computer font is used for on-screen prompts and messages.
HARDKEYS	Labeled keys on the instrument front panel are enclosed in  .
SOFTKEYS	Softkeys located to the right of the CRT are enclosed in  .

Certification

Agilent Technologies certifies that this product met its published specifications at the time of shipment from the factory. Agilent Technologies further certifies that its calibration measurements are traceable to the United States National Institute of Standards and Technology, to the extent allowed by the Institution's calibration facility, or to the calibration facilities of other International Standards Organization members.

Warranty

This Agilent Technologies instrument product is warranted against defects in material and workmanship for a period of one year from the date of shipment, except that in the case of certain components listed in *Instrument Specifications* of this manual, the warranty shall be for the specified period. During the warranty period, Agilent Technologies will, at its option, either repair or replace products that prove to be defective.

For warranty service or repair, this product must be returned to a service facility designated by Agilent Technologies. Buyer shall prepay shipping charges to Agilent Technologies and Agilent Technologies shall pay shipping charges to return the product to Buyer. However, Buyer shall pay all shipping charges, duties, and taxes for products returned to Agilent Technologies from another country.

Agilent Technologies warrants that its software and firmware designated by Agilent Technologies for use with an instrument will execute its programming instruction when properly installed on that instrument. Agilent Technologies does not warrant that the operation of the instrument, or software, or firmware will be uninterrupted or error free.

Limitation Of Warranty

The foregoing warranty shall not apply to defects resulting from improper or inadequate maintenance by Buyer, Buyer-supplied software or interfacing, unauthorized modification or misuse, operation outside of the environmental specifications for the product, or improper site preparation or maintenance.

No other warranty is expressed or implied. Agilent Technologies specifically disclaims the implied warranties of merchantability and fitness for a particular purpose.

Exclusive Remedies

The remedies provided herein are buyer's sole and exclusive remedies. Agilent Technologies shall not be liable for any direct, indirect, special, incidental, or consequential damages, whether based on contract, tort, or any other legal theory.

Assistance

Product maintenance agreements and other customer assistance agreements are available for Agilent Technologies products.

For any assistance, contact your nearest Agilent Technologies Sales and Service Office. Addresses are provided at the back of this manual.

Safety Symbols

General definitions of safety symbols used on equipment or in manuals are listed below.



Instruction manual symbol: the product is marked with this symbol when it is necessary for the user to refer to the instruction manual.



Alternating current.



Direct current.



On (Supply).



Off (Supply).

Warning



This **Warning** sign denotes a hazard. It calls attention to a procedure, practice, condition or the like, which, if not correctly performed or adhered to, could result in injury or death to personnel.

Caution



This **Caution** sign denotes a hazard. It calls attention to a procedure, practice, condition or the like, which, if not correctly performed or adhered to, could result in damage to or destruction of part or all of the product.

Note



This **Note** sign denotes important information. It calls attention to a procedure, practice, condition or the like, which is essential to highlight.

Document Guide

Please utilize the following manuals when using the analyzer:

Function Reference

Explains the operations commonly used for measurement and illustrates all functions accessed from the front panel keys and softkeys. It also provides information on options and accessories available, specifications, system performance, and conceptual information about the analyzer's features.

GPIB Programming Manual

Explains the basic programming methods used when remotely controlling the analyzer with GPIB. Also, contains information on the usage of all GPIB commands, the status report mechanism, and the data transmission format.

Manual Supplement for HP Instrument BASIC User's Handbook

Describes how HP Instrument BASIC works with the analyzer.

HP Instrument BASIC User's Handbook

Explains the usage of HP Instrument BASIC including general programming examples and hints. Also, explains all HP Instrument BASIC commands. This manual consists of the following three parts: "HP Instrument BASIC Programming Technique," "HP Instrument BASIC Interface Technique," and "HP Instrument BASIC Language Reference."

Service Manual

Explains how to do performance tests, and to adjust, troubleshoot, and repair the instrument.

Contents

1. General Information

INTRODUCTION	1-1
ORGANIZATION OF SERVICE MANUAL	1-1
ANALYZERS COVERED BY THIS MANUAL	1-3
TABLE OF SERVICE TEST EQUIPMENT	1-4

2. Performance Tests

INTRODUCTION	2-1
GENERAL INFORMATION	2-1
Warm Up Time	2-1
Ambient Conditions	2-1
Calibration Cycle	2-1
Performance Test Record	2-1
Recommended Test Equipment	2-2
FREQUENCY MEASUREMENT TEST	2-3
Description	2-3
Specification	2-3
Test Equipment	2-3
Procedure	2-3
RF POWER MEASUREMENT ACCURACY TEST	2-5
Description	2-5
Specification	2-5
Test Equipment	2-5
Procedure	2-5
C/N RATIO MEASUREMENT PHASE NOISE TEST	2-11
Description	2-11
Specification	2-11
Test Equipment	2-11
Procedure	2-11
C/N MEASUREMENT FLATNESS ACCURACY TEST	2-13
Description	2-13
Specification	2-13
Test Equipment	2-13
Procedure	2-13
C/N RATIO MEASUREMENT LINEARITY ACCURACY TEST	2-16
Description	2-16
Specification	2-16
Test Equipment	2-16
Procedure	2-16
FM DEVIATION TEST	2-19
Description	2-19
Specification	2-19
Test Equipment	2-19
Procedure	2-19
SPECTRUM MEASUREMENT RELATIVE LEVEL ACCURACY TEST	2-25
Description	2-25

Specification	2-25
Test Equipment	2-25
Procedure	2-25
FREQUENCY TRANSIENT FREQUENCY ACCURACY TEST	2-28
Description	2-28
Specification	2-28
Test Equipment	2-28
Procedure	2-28
DC POWER VOLTAGE ACCURACY TEST	2-30
Description	2-30
Specification	2-30
Test Equipment	2-30
Procedure	2-30
DC CONTROL VOLTAGE ACCURACY TEST	2-32
Description	2-32
Specification	2-32
Test Equipment	2-32
Procedure	2-32
MOD OUT LEVEL ACCURACY TEST	2-34
Description	2-34
Specification	2-34
Test Equipment	2-34
Procedure	2-34
DC POWER CURRENT MEASUREMENT ACCURACY TEST	2-36
Description	2-36
Specification	2-36
Test Equipment	2-36
Procedure	2-36
PERFORMANCE TEST RECORD	2-38
Frequency Measurement Test	2-38
Power Measurement Accuracy Test	2-38
C/N Phase Noise Test	2-38
C/N Measurement Accuracy Test (Flatness)	2-39
C/N Measurement Accuracy Test (Linearity)	2-39
FM Deviation Test	2-39
Spectrum Measurement Relative Level Accuracy Test	2-40
Frequency Transient Frequency Accuracy Test	2-40
DC POWER Voltage Test	2-40
DC CONTROL Voltage Test	2-41
MOD OUT Voltage Test	2-41
DC POWER Current Test	2-41
3. Adjustments and Correction Constants	
Introduction	3-1
Safety Considerations	3-1
Required Equipment	3-2
Adjustment Program	3-2
Warm-up for Adjustments and Correction Constants	3-3
Instrument Cover Removal	3-3
Order Of Adjustments and Correction Constants	3-3
Preparation for Using the Adjustment Program	3-4
REFERENCE FREQUENCY ADJUSTMENT	3-8
Required Equipment	3-8
Procedure	3-8
THIRD MIXER FEEDTHROUGH ADJUSTMENT	3-10

Required Equipment	3-10
Procedure	3-10
THIRD IF AMP GAIN ADJUSTMENT	3-11
Required Equipment	3-11
Procedure	3-11
EEPROM WRITE-ID AND INITIAL CORRECTION CONSTANTS	3-13
Required Equipment	3-13
Procedure	3-13
CRYSTAL FILTER FREQUENCY RESPONSE CORRECTION CONSTANTS	3-14
Required Equipment	3-14
Procedure	3-14
FV CONVERTER CORRECTION CONSTANTS	3-15
Required Equipment	3-15
Procedure	3-15
DC POWER VOLTAGE CORRECTION CONSTANTS	3-16
Test Equipment	3-16
Procedure	3-16
DC CONTROL VOLTAGE CORRECTION CONSTANTS	3-17
Required Equipment	3-17
Procedure	3-17
MOD OUT LEVEL CORRECTION CONSTANTS	3-18
Required Equipment	3-18
Procedure	3-18
DC POWER CURRENT CORRECTION CONSTANTS	3-19
Test Equipment	3-19
Procedure	3-19
RF POWER LINEARITY CORRECTION CONSTANTS	3-20
Required Equipment	3-20
Procedure	3-20
RF POWER FLATNESS CORRECTION CONSTANTS	3-22
Required Equipment	3-22
Procedure	3-22
SPECTRUM MEASUREMENT CORRECTION CONSTANTS	3-23
Required Equipment	3-23
Procedure	3-23

4. Overall Troubleshooting

INTRODUCTION	4-1
TROUBLESHOOTING SUMMARY	4-1
START HERE	4-3
INSPECT THE POWER ON SEQUENCE	4-4
Check the Fan	4-4
Check the Front Panel LED	4-4
Check Error Message	4-4
OPERATOR'S CHECK	4-5
Test Equipment	4-5
Procedure to check the source group	4-5
Procedures to check the receiver group	4-6
PERFORMANCE TESTS FAILURE TROUBLESHOOTING	4-9
Perform Adjustments and Correction Constants	4-9
TROUBLESHOOTING GPIB SYSTEM	4-10
Check the GPIB system with the signal generator	4-10
Check the External Controller	4-11

5. Power Supply Troubleshooting	
INTRODUCTION	5-1
START HERE	5-2
1. Check Error Messages	5-2
2. Check the Fan is Rotating	5-2
3. Check the A50 SHUTDOWN LED	5-2
A50 Shutdown LED	5-3
4. Check the A1 +5 VD LED	5-4
Measure the A1 +5 VD Voltage	5-4
5. Check the A2 Seven LEDs	5-4
6. Run the Internal Test 4: A2 POST REGULATOR	5-5
Internal Test 4: A2 POST REGULATOR	5-6
FIND OUT WHY THE FAN IS NOT ROTATING	5-7
1. Check the Line Voltage, Selector Switch Setting, and Fuse	5-7
2. Check the A50 SHUTDOWN LED	5-7
FIND OUT WHY THE A50 SHUTDOWN LED IS OFF	5-8
1. Disconnect the Cable from the A50J3	5-8
2. Disconnect the Cable from the A1J10	5-8
3. Remove Assemblies	5-8
FIND OUT WHY THE A1 +5 VD LED IS NOT ON STEADILY	5-9
1. Check the A40 Pre-Regulator	5-9
2. Check the A50 DC-DC Converter	5-9
3. Disconnect Cables on the A1 CPU	5-10
4. Remove Assemblies	5-10
TROUBLESHOOT THE FAN AND THE A50 DC-DC CONVERTER	5-12
1. Troubleshoot the Fan	5-12
2. Troubleshoot the A50 DC-DC Converter	5-13
TROUBLESHOOT A2 POST-REGULATOR	5-15
1. Measure A2 Post Regulator Output Voltages	5-15
6. Digital Control Troubleshooting	
INTRODUCTION	6-1
A1 CPU Replacement	6-3
FIRMWARE INSTALLATION	6-4
Ordering the Firmware Diskette	6-4
START HERE	6-5
1. Check the Power On Sequence	6-5
Check the A1 Eight LEDs	6-5
Check Error Messages	6-6
2. Check the A1 CPU	6-6
3. Check the A1 DRAM and Flash Memory	6-7
4. Check the A1 Volatile Memory	6-8
5. Check the A30 Front Keyboard	6-8
6. Check the A53 FDD	6-8
7. Check the A32 I-BASIC Interface and the mini-DIN Keyboard	6-9
8. Check the A17 24 bit I/O Port	6-9
TROUBLESHOOT THE A51 GSP and A52 LCD	6-10
1. Run the Internal Test 3: A51 GSP	6-10
2. Check the A52 LCD(Liquid Crystal Display)	6-10

7. Source Group Troubleshooting	
INTRODUCTION	7-1
SOURCE GROUP TROUBLESHOOTING SUMMARY	7-2
START HERE	7-4
1. Check A6's A/D Converter	7-4
2. Check Option 001 DC CONTROL Outputs	7-4
3. Bypass A70	7-5
4. Check DC POWER/DC CONTROL Outputs	7-5
5. Check A3/A13 Source	7-7
6. Check MOD OUT signal	7-8
7. Check REF OSC on A6	7-8
8. Receiver Group Troubleshooting	
INTRODUCTION	8-1
RECEIVER GROUP TROUBLESHOOTING SUMMARY	8-2
START HERE	8-4
1. Check the Rear Panel Output signals (40MHz Output/INT_REF OUTPUT)	8-4
2. Check A6 Spectrum Analyzer	8-4
3. Check A5 2nd PLL	8-7
4. Check Measurement Functions	8-9
5. Check A11 Thermometer	8-10
6. Check the outputs from A10 1st Mixer	8-10
7. Check the Residual FM	8-12
8. Check the Frequency Transient measurement	8-13
9. Service Key Menus	
INTRODUCTION	9-1
SERVICE MENU	9-3
TESTS	9-3
SERVICE INSTRUMENT	9-3
SERVICE MODES (:DIAG:SERV:MODE {OFF ON 0 1})	9-3
FIRMWARE REVISION (:DIAG:FREV?)	9-4
TESTS MENU	9-5
EXECUTE TEST (:DIAG:TEST:EXEC)	9-5
INTERNAL TESTS (:DIAG:TEST 0)	9-6
EXTERNAL TESTS (:DIAG:TEST 11)	9-6
DISPLAY TESTS (:DIAG:TEST 21)	9-6
Test Status	9-6
Diagnostic Tests	9-7
Test Descriptions	9-8
INTERNAL TESTS	9-8
0: ALL INT	9-8
1: A1 CPU	9-8
2: A1 VOLATILE MEMORY	9-8
3: A51 GSP	9-9
4: A2 POST REGULATOR	9-9
5 through 10: N/A	9-9
EXTERNAL TESTS	9-9
11: FRONT PANEL DIAG.	9-9
12: DSK DR FAULT ISOL'N	9-9
13: 24 BIT I/O PORT	9-9
14 through 20: N/A	9-10

DISPLAY TESTS	9-10
21: TEST PATTERN 1	9-10
22: TEST PATTERN 2	9-10
23: TEST PATTERN 3	9-10
24: TEST PATTERN 4	9-10
25: TEST PATTERN 5	9-10
SERVICE MODES MENU	9-11
BUS MEAS [ON]	9-11
MISC MENU	9-11
CORRECTION CONSTANTS	9-11
A2/A8	9-12
A3	9-12
A5	9-12
A6	9-12
A70	9-12
Service Modes	9-12
BUS MEASUREMENT MENU	9-13
BUS MEAS ON <i>off</i> (:DIAG:SERV:BUS:STAT {ON OFF 1 0})	9-13
DC BUS [FAN PWR] (:DIAG:SERV:BUS:DC <i><numeric></i>)	9-13
FREQ BUS [OFF] (:DIAG:SERV:BUS:FREQ <i><numeric></i>)	9-14
WAIT COUNT (:DIAG:SERV:BUS:WAIT <i><numeric></i>)	9-14
Bus Measurement	9-14
Bus Measurement Procedure	9-14
Bus Measurement Values	9-15
DC Bus Node Descriptions	9-15
0: NONE	9-15
1: [A2] +5 V (AUX) (2.025 U)	9-15
2: [A2] -15 V (-1.92 U)	9-15
3: [A2] -12.6 V (-2.124 U)	9-15
4: [A2] -5 V (-2.025 U)	9-15
5: [A2] +5 V (2.025 U)	9-15
6: [A2] +5.3 V (2.1465 U)	9-15
7: [A2] +8.5 V (1.8955 U)	9-15
8: [A2] +15 V (AUX) (1.92 U)	9-16
9: [A2] +15 V (1.92 U)	9-16
10: [A2] +22 V (2.002 U)	9-16
11: [A2] FAN POWER	9-16
12: [A2] +65 V (2.0605 U)	9-16
13 through 19: Not Assigned	9-16
20: [A3] +20VB	9-16
21: [A3] -5VB	9-16
22: [A3] +25VC	9-16
23: [A3] -5VC	9-16
24: [A3] DC POWER	9-16
25: [A3] DC CONTROL	9-17
26 through 29: Not Assigned	9-17
30: [A5] VCO VTUNE	9-17
31: [A5] 2ND IF DC OFFSET	9-17
32 through 39: Not Assigned	9-17
40: [A6] AD VREF	9-17
41: [A6] REF LOOP VTUNE	9-17

42: [A6] FIXED PLL VTUNE	9-17
43: [A6] FN LOOP VTUNE	9-17
44: [A6] PEAK DETECTOR	9-17
45: [A6] GND	9-17
46 through 49: Not Assigned	9-17
50: [A6] SA PATH	9-18
51: [A6] MONITOR PATH	9-18
Frequency Bus Node Descriptions	9-18
0: OFF	9-18
1: [A5] 2nd LOCAL	9-18
2: [A5] FREQ COUNTER	9-18
3: [A5] FV CONVERTER	9-18
4 through 9: Not Assigned	9-18
10: [A6] SAMPLE HOLD	9-18
11: [A6] FM FREQ	9-18
12: [A6] REF LOOP	9-18
13: [A6] FIXED PLL	9-18
14: [A6] FN LOOP	9-18
CORRECTION CONSTANTS MENU	9-19
XTAL FILT ON off	9-19
FV ON off	9-19
DCPOW VOLT CC ON off	9-20
DCPOW CURR CC ON off	9-20
DCCTL VOLT ON off	9-20
MOD OUT ON off	9-20
POW LIN ON off	9-20
POW TEMP ON off	9-20
POW FRESP ON off	9-20
NOISE ATTN ON off	9-20
SPEC WIDE ON off	9-20
SPEC NARR ON off	9-21
A2/A8 CONTROL MENU	9-22
RF ATTN:	9-22
POW FAIL LOCATION	9-22
A3/A13 CONTROL MENU	9-23
DAC MENU	9-23
RANGE MENU	9-24
OUTPUT SELECT	9-24
STATUS	9-24
A5 CONTROL MENU	9-25
2nd PLL	9-25
FREQ COUNTER	9-26
FV CONVERTER	9-26
IF	9-26
STATUS	9-26
INTERNAL STATUS	9-26
A6 CONTROL MENU	9-27

ATTEN/AMP	9-27
IF GAIN	9-28
INPUT SELECT	9-28
PLL	9-28
FV CALOUT on OFF	9-28
FM OUT on OFF	9-28
STATUS	9-28
BOOTLOADER MENU	9-29
SYSTEM UPDATE	9-29
SYSTEM BACKUP	9-29
PREVIEW DISK	9-30
REBOOT	9-30

10. Theory of Operation

OVERALL OPERATION AND FUNCTIONAL GROUPS	10-1
POWER SUPPLY OPERATION	10-2
Line Power Module	10-4
A40 Preregulator	10-4
A50 DC-DC Converter	10-4
Switching Regulator 1	10-4
Switching Regulator 2	10-4
Regulated +5V Digital Supply (+5 VD)	10-4
A50 Shutdown LED	10-4
A2 Post-Regulator	10-5
Shutdown Circuit	10-5
Seven Status LEDs	10-5
A8 RF Attenuator Drive Circuit	10-6
DIGITAL CONTROL OPERATION	10-7
A1 CPU	10-9
A17 24 Bit I/O Port	10-9
A30 Front-Panel Keyboard	10-9
A31 I/O Connector	10-9
A32 I-BASIC Interface	10-10
A51 GSP	10-10
A54 Inverter	10-10
A52 LCD (Liquid Crystal Display)	10-10
A53 FDD	10-10
SOURCE THEORY	10-11
RECEIVER THEORY	10-12
A5 Second PLL	10-13
A6 Spectrum Analyzer	10-13
A7 Power Divider	10-13
A8 RF Attenuator	10-13
A9 Peak Detector	10-13
A10 First Mixer	10-13
A11 Thermometer	10-14
A part of A3/A13, A60	10-14

11. Replaceable Parts	
Introduction	11-1
Ordering Information	11-1
Direct Mail Order System	11-1
Replaceable Parts List	11-2
12. Post Repair Procedures	
INTRODUCTION	12-1
POST REPAIR PROCEDURES	12-1
A. Manual Changes	
Introduction	A-1
Manual Changes	A-1
Change 1	A-2
Serial Number	A-5
B. Power Requirement	
 Replacing Fuse	B-1
Fuse Selection	B-1
Power Requirements	B-2
Power Cable	B-2
Messages	
Error Messages in Alphabetical Order	Messages-2
Error Messages in Numerical Order	Messages-15

Index

Figures

1-1. Serial Number Plate	1-3
2-1. Frequency Measurement Test Setup	2-3
2-2. Power Splitter Tracking Error Measurement Setup 1	2-6
2-3. Power Splitter Tracking Error Measurement Setup 2	2-7
2-4. RF Power Measurement Accuracy Test Setup 1	2-8
2-5. RF Power Measurement Accuracy Test Setup 2	2-9
2-6. C/N Measurement Phase Noise Test Setup	2-11
2-7. C/N Ratio Measurement Accuracy (Flatness) Test Setup	2-14
2-8. C/N Ratio Measurement Accuracy (Linearity) Test Setup	2-17
2-9. FM Deviation Accuracy Test Setup 1	2-19
2-10. FM Deviation Accuracy Test Setup 2	2-21
2-11. FM Deviation Accuracy Test Setup 3	2-22
2-12. FM Deviation Accuracy Test Setup 4	2-22
2-13. FM Deviation Accuracy Test Setup 5	2-23
2-14. FM Deviation Accuracy Test Setup 6	2-24
2-15. Relative Level Accuracy Test Setup	2-26
2-16. Frequency Transient Frequency Accuracy Setup	2-28
2-17. DC Power Voltage Accuracy Test Setup	2-30
2-18. DC Control Voltage Accuracy Test Setup	2-32
2-19. MOD OUT Voltage Test Setup	2-34
2-20. DC Power Current Test Setup	2-36
3-1. Updating Correction Constants Setup	3-4
3-2. 4352B Adjustment Program Basic Menu	3-5
3-3. Setup Menu	3-6
3-4. List Box Menu	3-7
3-5. Reference Frequency Adjustment Setup	3-8
3-6. Reference Frequency Adjustment Location	3-9
3-7. Third Mixer Feedthrough Adjustment Location	3-10
3-8. Third IF AMP GAIN Adjustment Setup	3-11
3-9. Third IF AMP GAIN Adjustment Location	3-12
3-10. Crystal Filter Frequency Response Correction Constants Setup	3-14
3-11. F-V Converter Correction Constants Setup	3-15
3-12. DC Power Voltage Correction Constants Setup	3-16
3-13. DC Control Voltage Correction Constants Setup	3-17
3-14. MOD OUT Level Correction Constants Setup	3-18
3-15. DC Power Current Correction Constants Setup	3-19
3-16. RF Power Linearity Correction Constants Setup 1	3-20
3-17. RF Power Linearity Correction Constants Setup 2	3-21
3-18. RF Power Flatness Correction Constants Setup	3-22
3-19. Spectrum Measurement Correction Constants Setup	3-24
3-20. Power Splitter Tracking Error Measurement Setup 1	3-25
3-21. Power Splitter Tracking Error Measurement Setup 2	3-26
3-22. Absolute Amplitude Measurement Accuracy Test Setup	3-27
4-1. Troubleshooting Organization	4-2
4-2. Source Group Check Setup	4-5
4-3. Receiver Group Check Setup	4-7

5-1. A50 SHUTDOWN LED Location	5-3
5-2. A1 +5 VD LED Location	5-4
5-3. A2 Eight LED Locations	5-5
5-4. Displayed Test Result	5-5
5-5. Removing Line Fuse	5-7
5-6. A40J1 Output Voltage	5-9
5-7. A1 CPU Connector Locations	5-10
5-8. Fan Troubleshooting Setup	5-12
5-9. A50 DC-DC Converter Troubleshooting Setup	5-13
5-10. A2 Output Voltage Measurement Setup	5-15
5-11. Power Supply Block Diagram 1	5-17
5-12. Power Supply Block Diagram 2	5-18
5-13. Power Supply Block Diagram 3	5-19
6-1. Digital Control Group Simplified Block Diagram	6-2
6-2. A1 EEPROM Location	6-3
6-3. Firmware Revision Label	6-4
6-4. A1 Eight LEDs' Pattern	6-5
6-5. Bootloader Display	6-7
6-6. A17 24 bit I/O Port Test Setup	6-9
7-1. Source Group Block Diagram	7-2
7-2. Source Group Troubleshooting Flow	7-3
7-3. Option 001 DC CONTROL Output Test Setup	7-4
7-4. DC POWER Output Test Setup	7-6
7-5. MOD OUT Signal Test Setup	7-8
8-1. Receiver Group Block Diagram	8-2
8-2. Receiver Group Troubleshooting Flow	8-3
8-3. 40MHz Output/INT_REF OUTPUT Signals Test Setup	8-4
8-4. A6 Peak Detector Test Setup	8-6
8-5. Measurement Functions Test Setup	8-9
8-6. A10 Output Test Setup 1	8-11
8-7. A10 Output Test Setup 2	8-11
8-8. FM Deviation Residual FM Test Setup	8-13
8-9. Frequency Transient Measurement Test Setup	8-14
9-1. Service Key Menus	9-1
9-2. Service Menu	9-3
9-3. Tests Menu	9-5
9-4. Test Status on the Display	9-6
9-5. Sample Program Using :DIAG:TEST:RES?	9-7
9-6. Service Modes Menu	9-11
9-7. Bus Measurement Menu	9-13
9-8. Correction Constants Menu	9-19
9-9. A2/A8 Control Menu	9-22
9-10. A3/A13 Control Menu	9-23
9-11. A5 Control Menu	9-25
9-12. A6 Control Menu	9-27
9-13. Bootloader Menu	9-29
10-1. Power Supply Functional Group, Simplified Block Diagram	10-3
10-2. A2 Eight Status LED	10-6
10-3. Digital Control Group Simplified Block Diagram	10-8
10-4. Source Group Simplified Block Diagram	10-11
10-5. Receiver Group Simplified Block Diagram	10-12
11-1. Top View	11-4
11-2. Bottom View	11-5
11-3. Front Assembly Parts 1	11-6
11-4. Front Assembly Parts 2	11-7

11-5. Front Assembly Parts 3	11-8
11-6. Front Assembly Parts 4	11-9
11-7. Front Assembly Parts 5	11-10
11-8. Front Assembly Parts 6	11-11
11-9. Front Assembly Parts 7	11-12
11-10. Front Assembly Parts 8	11-13
11-11. Front Assembly Parts 9	11-14
11-12. Rear Assembly Parts 1	11-15
11-13. Rear Assembly Parts 2	11-16
11-14. Rear Assembly Parts 3	11-17
11-15. Rear Assembly Parts 4	11-18
11-16. Rear Assembly Parts 5	11-19
11-17. Rear Assembly Parts 6	11-20
11-18. Rear Assembly Parts 7	11-21
11-19. 1st Mixer Board -1	11-22
11-20. 1st Mixer Board -2	11-23
11-21. Power Switch ASSY	11-24
11-22. Chassis/Frames -1	11-25
11-23. Chassis/Frames -2	11-26
11-24. 1st Mixer Installation	11-27
11-25. FDD Assembly	11-28
11-26. Motherboard Installation	11-29
11-27. CPU Board Installation	11-30
11-28. Saddle Edge	11-31
11-29. Preregulator Installation	11-32
11-30. DC-DC Converter Installation	11-33
11-31. Front Panel Installation	11-34
11-32. Troidal Core	11-35
11-33. Front Bezel	11-36
11-34. Rear Panel Installation	11-37
11-35. Covers	11-38
11-36. DC/FM Source Board ASSY	11-39
11-37. DC/FM Source Board Installation	11-40
11-38. GSP Board Installation	11-41
11-39. Post-Regulator Installation	11-42
11-40. Receiver Board and Spe Ana Board	11-43
11-41. Cables	11-44
11-42. Output Filter ASSY	11-45
11-43. DC Offset (Option 001)	11-46
11-44. 24 Bit I/O Board	11-47
11-45. Top Shield Plate	11-48
11-46. BNC-BNC Adapter	11-49
11-47. Top Covers/Foot	11-50
A-1. Front Assembly Parts 5	A-2
A-2. Front Assembly Parts 6	A-3
A-3. Front Assembly Parts 7	A-4
A-4. Serial Number Plate	A-5
B-1. Power Cable Supplied	B-3

Tables

1-1. Recommended Test Equipment	1-4
4-1. Recommended Adjustments and Correction Constants	4-9
4-2. Default GPIB Addresses	4-10
4-3. SG Type	4-10
5-1. A50 Power Supplies	5-14
5-2. Power Supplies on A2 Post-Regulator	5-16
9-1. Test Status Terms	9-7
11-1. Manufacturers Code List	11-2
11-2. List of Abbreviations	11-3
11-3. Top View	11-4
11-4. Bottom View	11-5
11-5. Front Assembly Parts 1	11-6
11-6. Front Assembly Parts 2	11-7
11-7. Front Assembly Parts 3	11-8
11-8. Front Assembly Parts 4	11-9
11-9. Front Assembly Parts 5	11-10
11-10. Front Assembly Parts 6	11-11
11-11. Front Assembly Parts 7	11-12
11-12. Front Assembly Parts 8	11-13
11-13. Front Assembly Parts 9	11-14
11-14. Rear Assembly Parts 1	11-15
11-15. Rear Assembly Parts 2	11-16
11-16. Rear Assembly Parts 3	11-17
11-17. Rear Assembly Parts 4	11-18
11-18. Rear Assembly Parts 5	11-19
11-19. Rear Assembly Parts 6	11-20
11-20. Rear Assembly Parts 7	11-21
11-21. 1st Mixer Board -1	11-22
11-22. 1st Mixer Board -2	11-23
11-23. Power Switch ASSY	11-24
11-24. Chassis/Frames -1	11-25
11-25. Chassis/Frames -2	11-26
11-26. 1st Mixer Installation	11-27
11-27. FDD Assembly	11-28
11-28. Motherboard Installation	11-29
11-29. CPU Board Installation	11-30
11-30. Saddle Edge	11-31
11-31. Preregulator Installation	11-32
11-32. DC-DC Converter Installation	11-33
11-33. Front Panel Installation	11-34
11-34. Troidal Core	11-35
11-35. Front Bezel	11-36
11-36. Rear Panel Installation	11-37
11-37. Covers	11-38
11-38. DC/FM Source Board ASSY	11-39
11-39. DC/FM Source Board Installation	11-40

11-40. GSP Board Installation	11-41
11-41. Post-Regulator Installation	11-42
11-42. Receiver Board and Spe Ana Board	11-43
11-43. Cables	11-44
11-44. Output Filter ASSY	11-45
11-45. DC Offset (Option 001)	11-46
11-46. 24 Bit I/O Board	11-47
11-47. Top Shield Plate	11-48
11-48. BNC-BNC Adapter	11-49
11-49. Top Covers/Foot	11-50
12-1. Post Repair Procedures	12-2
A-1. Manual Changes by Serial Number	A-1
A-2. Manual Changes by Firmware Version	A-1
A-3. Front Assembly Parts 5	A-2
A-4. Front Assembly Parts 6	A-3
A-5. Front Assembly Parts 7	A-4
B-1. Fuse Selection	B-1

General Information

INTRODUCTION

This *Service Manual* is a guide to servicing the 4352B VCO/PLL Signal Analyzer. The *Service Manual* provides information about performance testing, adjusting, troubleshooting, and repairing the 4352B.

ORGANIZATION OF SERVICE MANUAL

This manual consists of the major chapters listed below. The chapters are divided by tabs. This section describes the names of the tabs and the content of each chapter.

- *Performance Tests* provides procedures for performance testing the 4352B.
- *Adjustments and Correction Constants* provides procedures for adjusting the analyzer after repair or replacement of an assembly. Some of the adjustments update correction constants stored into the EEPROM on the A1 CPU. The correction constants are updated by using the adjustment program.

Note The next five chapters are the core troubleshooting chapters.



-
- *Overall Troubleshooting* outlines the 4352B troubleshooting, and provides troubleshooting procedures to isolate the faulty functional group. Faulty assembly isolation procedures for each functional group follow this chapter.
 - *Power Supply Troubleshooting*
 - *Digital Control Troubleshooting*
 - *Source Group Troubleshooting*
 - *Receiver Group Troubleshooting*

Note The following chapters are, for the most part, reference material.



-
- *Service Key Menus* documents the functions of the menus accessed from (System), SERVICE MENU. These menus let the operator test, verify, adjust, control, and troubleshoot the analyzer. GPIB service mnemonics are included.
 - *Theory of Operation* explains the overall operation of the analyzer, the division into functional groups, and the operation of each functional group.

- *Replaceable Parts* provides part numbers and illustrations of the replaceable assemblies and miscellaneous chassis parts, together with ordering information. It also can be used as the replacement procedure reference.
- *Post-Repair Procedures* contains the table of related service procedures. It is a table of adjustments and verification procedures to be performed after repair or replacement of each assembly.
- *Appendices* contains manual change information (required to make this manual compatible with earlier shipment configurations of the analyzer), and power requirements.
- *Messages* contains the service related error message list.

ANALYZERS COVERED BY THIS MANUAL

Agilent Technologies uses a two-part, ten-character serial number that is stamped on the serial number plate (see Figure 1-1) attached to the rear panel. The first five digits and letters are the serial prefix and the last five digits are the suffix. The first two letters identify the country where the instrument was manufactured. The same prefix is used for all identical instruments. The prefix changes only when a change is made to the instrument. However, the suffix is assigned sequentially and is unique to each instrument. The contents of this manual apply to instruments with the serial number prefixes listed under **SERIAL NUMBERS** on the title page.



Figure 1-1. Serial Number Plate

An instrument manufactured after the printing date of this manual may have a serial number prefix that is not listed on the title page. This unlisted serial number prefix indicates that the instrument is different from those described in this manual. The manual for an unlisted instrument may be accompanied by a yellow *Manual Changes* supplement or have a different manual part number. The *Manual Changes* supplement contains “change information” that explains how to adapt the manual to newer instruments.

In addition to change information, the supplement may contain information for correcting errors (Errata) in the manual. To keep this manual as current and accurate as possible, Agilent Technologies recommends that you periodically request the latest *Manual Changes* supplement. The supplement for this manual is identified by this manual’s printing date and is available from Agilent Technologies. If the serial prefix or number of an instrument is lower than that on the title page of this manual, see *Appendix A, Manual Changes*.

For information concerning serial number prefixes not listed on the title page or in the *Manual Changes* supplement, contact the nearest Agilent Technologies office.

TABLE OF SERVICE TEST EQUIPMENT

The first part of Table 1-1 lists all of the equipment required to verify, adjust, and troubleshoot the analyzer and perform the operator's check. The table also notes the use and critical specifications of each item, and the recommended models. Equipment other than the recommended models may be substituted if the equipment meets or exceeds the critical specifications.

In addition to test equipment listed in Table 1-1, the following tools are also required:

- Torx screwdriver, T15
- Pozidriv screwdriver, pt size #1 (small)
- Pozidriv screwdriver, pt size #2 (medium)
- IC extractor
- Open-end wrench, 1/4 inch
- Open-end wrench, 5/16 inch
- Hex socket, 7/32 inch (5.5 mm)
- Flat edge screwdriver

Table 1-1. Recommended Test Equipment

Equipment	Critical Specifications	Recommended Model/Agilent Part Number	Qty	Use ¹
Computer	CPU: 80486, 33 MHz or faster; RAM: 16MB, OS: Windows 3.1, HP VEE, GPIB Card	HP Vectra Series with HP E2120C, 82335B/82340A	1	A
Program	4352B Adjustment Program	PN 04352-18010	1	A
Signal Generator	Freq.Range 10 MHz to 2 GHz	8664A #004 or 8642B	1	A, P
Signal Generator	Freq.Range 10 MHz to 3 GHz	8664A #004 or 8665B #004	1	A, P
Network Analyzer	Freq.Range to 3 GHz	8753D	1	A, P
Function Generator	Freq.Range: 80 kHz, Level: -20 dBm	3325B	1	A
Frequency Counter	Freq.Range: 10 MHz to 3 GHz	5343A Opt.001, 5334B	1	P, A, T
Power Meter	No Substitute	436A Opt.022, 437B, or 438A	2	P, A, T
Power Sensor	Frequency Range: 10 MHz to 3 GHz, Power: +5 dBm to -20 dBm, Freqnecy: 10 MHz to 3 GHz	8482A	2	P, A, T
DVM	No Substitute	3458A	1	P, A, T
AM/FM Test Source	No Substitute	11715A	1	A, T
Power Amplifier	Gain: 35 dB, Flatness:±1 dB	R & K A3000-2H-R	1	P, A, T
Power Divider	No Substitute	11636A	1	P
10 dB Fixed Attenuator	50Ω, N(m)-N(f)	8491A Opt.010, H60	1	P
Step Attenuator ²	Attenuation Range: 0 dB to 70 dB, Step: 10 dB, VSWR: ≤1.02	8496A/G Opt.001 and H60 ³	1	P

¹ P: Performance Tests, A: Adjustments and Correction Constants, T: Troubleshooting

² Calibration values at 10 MHz, 1 GHz are required.

³ 11713A is required when using a programmable step attenuator 8496G.

Table 1-1. Recommended Test Equipment (continued)

Equipment	Critical Specifications	Recommended Model/Agilent Part Number	Qty	Use ¹
50Ω Termination	Type-N (m), 50Ω	909C Opt.012 or part of 85032B ¹	P	
Power Splitter	Frequency Range: 100 kHz to 3 GHz, Output Tracking: ≤0.15dB	11667A	1	P, A, T
Oscilloscope	Bandwidth: ≥100 MHz	54111D	1	T
Oscilloscope Probe	Impedance: 1MΩ	10431A	1	T
Spectrum Analyzer	Frequency Range: > 80 MHz	8568B	1	T
Cables, Adapters	Type N Cable, 50Ω	11500B or Part of 11851B	3	P, A, T
	BNC Cable, 61 cm, 50Ω	PN 8120-1839	2	P, A, T
	BNC Cable, 122 cm, 50Ω	PN 8120-1840	2	P, A, T
	N(m)-N(m) Adapter, 50Ω	PN 1250-1475	2	P, A, T
	N(f)-SMA(m) Adapter, 50Ω	PN 1250-1562	2	P, A
	BNC Tee Adapter	PN 1250-0781	2	P, A
	N(m)-BNC(f) Adapter, 50Ω	PN 1250-1476	2	P, A, T
	SMB(m)-BNC(f) Adapter, 50Ω	PN 1250-1237	1	T
	RF Cable assembly	PN 04352-61616	1	T
	940Ω Resistor BOX	PN 04352-65002	1	T
	300Ω Resistor BOX	PN 04352-65001	1	P, A, T
	BNC(f)-Dual Banana Adapter	PN 1251-2277	1	P, A, T
	GPIB Cable	10833A/B/C	4	P, A, T
I/O Port Test Kit	PN 87510-65002	1	T	

¹ The 85032B includes a type-N(m) 50 Ω termination.

Performance Tests

INTRODUCTION

This chapter provides information on the 4352B VCO/PLL Signal Analyzer performance tests information. These performance tests are used to verify that the 4352B performance meets its specifications.

General information about the performance tests is provided first. Then, step by step procedures for each test are provided.

Each test procedure consists of the following parts:

Description:	describes the test procedure.
Test Equipment:	describes test equipment required in the test.
Procedure:	describes the test procedure step by step.

GENERAL INFORMATION

This section provides general information about the performance tests.

Warm Up Time

Allow the 4352B to warm up for at least 30 minutes before you execute any of the performance tests.

Ambient Conditions

Perform all performance tests within ambient conditions of $23 \pm 5^{\circ}\text{C}$, $\leq 70\% \text{RH}$.

Calibration Cycle

The 4352B requires periodic performance verification to remain in calibration. The frequency of performance verification depends on the operating and environmental conditions under which the 4352B is used. Verify the 4352B's performance at least every two years using the performance tests given in this chapter.

Performance Test Record

The Performance Test Record lists all test points, acceptable test limits, test result entry columns, and measurement uncertainties. The measurement uncertainty shows how accurately the 4352B's specifications are measured and depends on the test equipment used. The listed measurement uncertainties are valid only when the recommended test equipment is used.

The Performance Test Record is provided at the end of this chapter. Use the record as a master and make extra copies for performance testing.

Recommended Test Equipment

Table 1-1 lists the equipment required for performance testing the 4352B. Other equipment may be substituted if the equipment meets or exceeds the critical specifications given in Table 1-1.

FREQUENCY MEASUREMENT TEST

Description

This test measures the output frequency from the external signal generator, and verifies the frequency measurement accuracy over its entire frequency measurement range.

Specification

Frequency Range	10 MHz to 3 GHz
Resolution	
When @1kHz Selected as resolution	1 kHz
Accuracy	\pm (time base accuracy of the external signal source used + 1 kHz)

Test Equipment

Signal Generator (SG#2)	8664A/8665B
Network Analyzer	8753D
N(m)-N(m) cable, 61 cm, 2 ea.	11500B or part of 11851B
BNC cable; 122 cm, 2 ea.	PN 8120-1840
GPIB Cable	PN 8120-3445

Procedure

1. Connect the test equipment as shown in Figure 2-1.

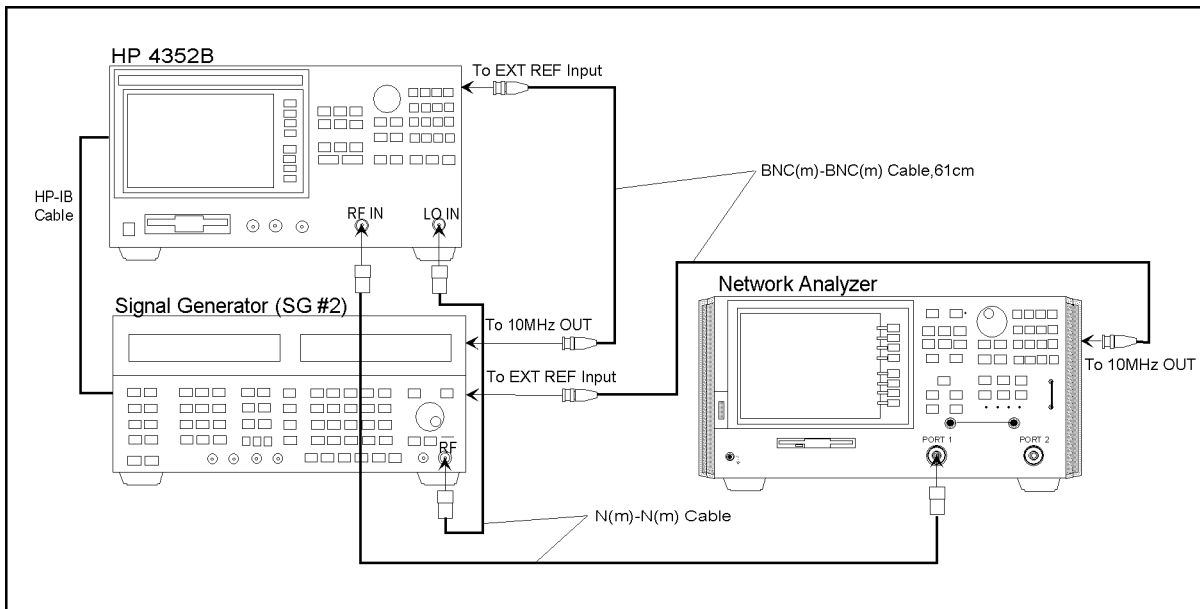

CDS02022

Figure 2-1. Frequency Measurement Test Setup

Note



Connect the signal generator's 10 MHz frequency reference output to the 4352B EXT REF Input on the rear panel as shown in Figure 2-1. With this configuration, both the signal generator and the 4352B are phase locked to the same reference frequency to obtain a stable measurement.

Note

In this test, the 4352B uses the signal generator (SG#2) as the first local oscillator. The 4352B automatically controls SG#2 via GPIB by performing the following procedures.

- a. Connect the GPIB cable between the 4352B and the signal generator.
 - b. Press **(Local)**, **SYSTEM CONTROLLER**. Then press **SET ADDRESSES**, **ADDRESS: SG** and the entry keys to set the GPIB address of the signal generator (SG#2). (The factory default setting of the signal generator address is 19.)
 - c. Press **(RF/LO)**, **SG TYPE**, **(1)**, **(x1)** to set the signal generator type to the 8664A.
 - d. Press **(Preset)** to initialize the 4352B. Confirm that the SG#2's GPIB remote indicator is lit.
-
2. Press **(Meas)**, **INST TYPE**, **INST TYPE: VCO TESTER** to set the instrument type to the Tester Mode.
 3. Set the measurement controls as follows:
 - a. Press **(Preset)**, **(Meas)**, and **FREQUENCY** to set the measurement item to Frequency.
 - b. Press **(Sense Range)**, **FREQ RES: 1kHz** to set the frequency resolution to 1 kHz.
 4. Set the network analyzer's output to 10 MHz, 0 dBm.
 5. Read the 4352B measurement result. Subtract the network analyzer setting value from the 4352B reading, and record the calculated value in the performance test record.
 6. Change the network analyzer's output to the frequencies listed below. Repeat step 5 for each of these settings:
 - 100 MHz
 - 1 GHz
 - 3 GHz

RF POWER MEASUREMENT ACCURACY TEST

Description

This tests measures the output level of the signal generator with/without the power amplifier, and verifies the RF power measurement accuracy.

Specification

Frequency Range	10 MHz to 3 GHz
Input Level	-10 dBm to +20 dBm
Resolution	0.01 dB
Accuracy	
@ ≤ 2 GHz, ≤ 15 dBm, Peak Voltage Response, $23 \pm 10^\circ\text{C}$	± 0.6 dB
@Other than the above, Peak Voltage Response, $23 \pm 10^\circ\text{C}$	± 1.0 dB
@Peak Voltage Response, 0 to 40°C	± 2.0 dB

Test Equipment

Signal Generator (SG#2)	8664A/8665B
Power Amplifier (35 dB)	R & K A3000-2H-R
Power Meter, 2 ea.	436A
Power Sensor, 2 ea.	8482A
Power Splitter	11667A
10 dB Fixed Attenuator	8491A Opt.010, H60
50 Ω Termination, type-N(m)	909C Opt.012 or part of 85032B
N(m)-N(m) adapter, 50 Ω	PN 1250-1475
N(f)-SMA(m) adapter, 2 ea.	PN 1250-1562
N(m)-N(m) cable, 61 cm, 2 ea.	11500B or part of 11851B
BNC cable, 122 cm	PN 8120-1840

Procedure

1. Connect the power sensor #A to the power meter #A. Calibrate the power meter #A with the power sensor #A. Set the power meter #A's display unit to dBm. Connect the power sensor #B to the power meter #B. Calibrate the power meter #B with the power sensor #B. Set the power meter #B's display unit to dBm.
2. Obtain the tracking error data of the power splitter in accordance with the following procedures.
 - a. Connect the test equipment as shown in Figure 2-2.

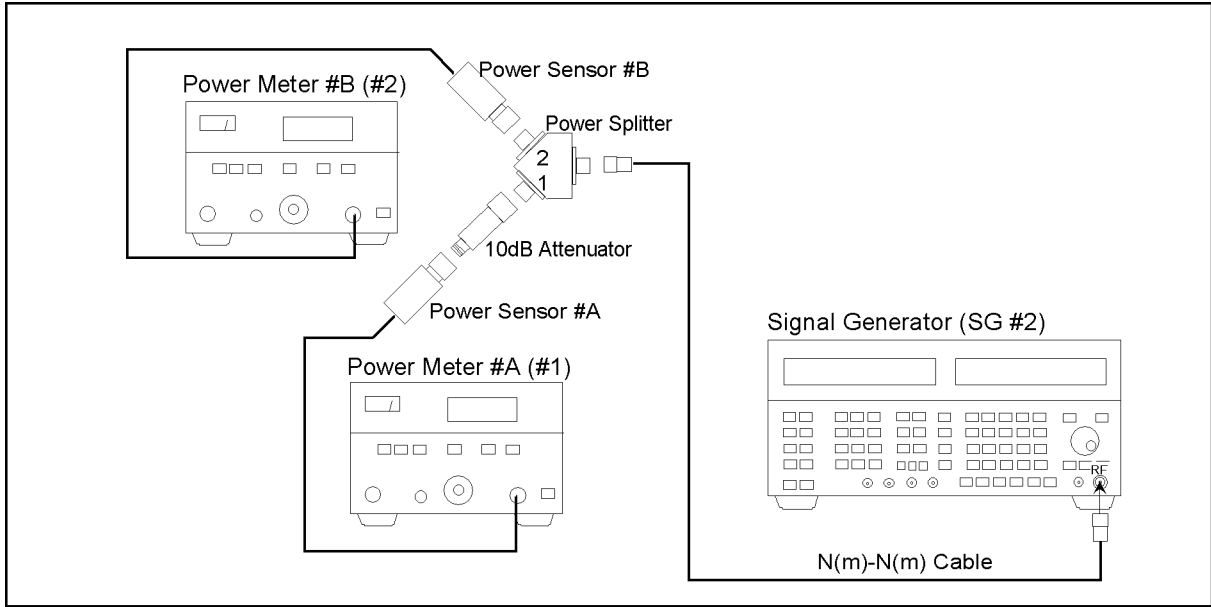

CDS02023

Figure 2-2. Power Splitter Tracking Error Measurement Setup 1

- b. Set the signal generator output level to 6 dBm.
- c. Set the output frequency of the signal generator in accordance with the following table, and record each power meter value at each frequency as PMA1(XXX) and PMB1(XXX) (where, XXX is the SG's setting frequency).

SG Frequency	Power Meter #A Value as:	Power Meter #B Value as:
10 MHz	PMA1(10M)	PMB1(10M)
50 MHz	PMA1(50M)	PMB1(50M)
100 MHz	PMA1(100M)	PMB1(100M)
500 MHz	PMA1(500M)	PMB1(500M)
1 GHz	PMA1(1G)	PMB1(1G)
1.5 GHz	PMA1(1.5G)	PMB1(1.5G)
2 GHz	PMA1(2G)	PMB1(2G)
2.5 GHz	PMA1(2.5G)	PMB1(2.5G)
3 GHz	PMA1(3G)	PMB1(3G)

- d. Reverse the power sensor with 10 dB attenuator connections on the Power Splitter as shown in Figure 2-3.

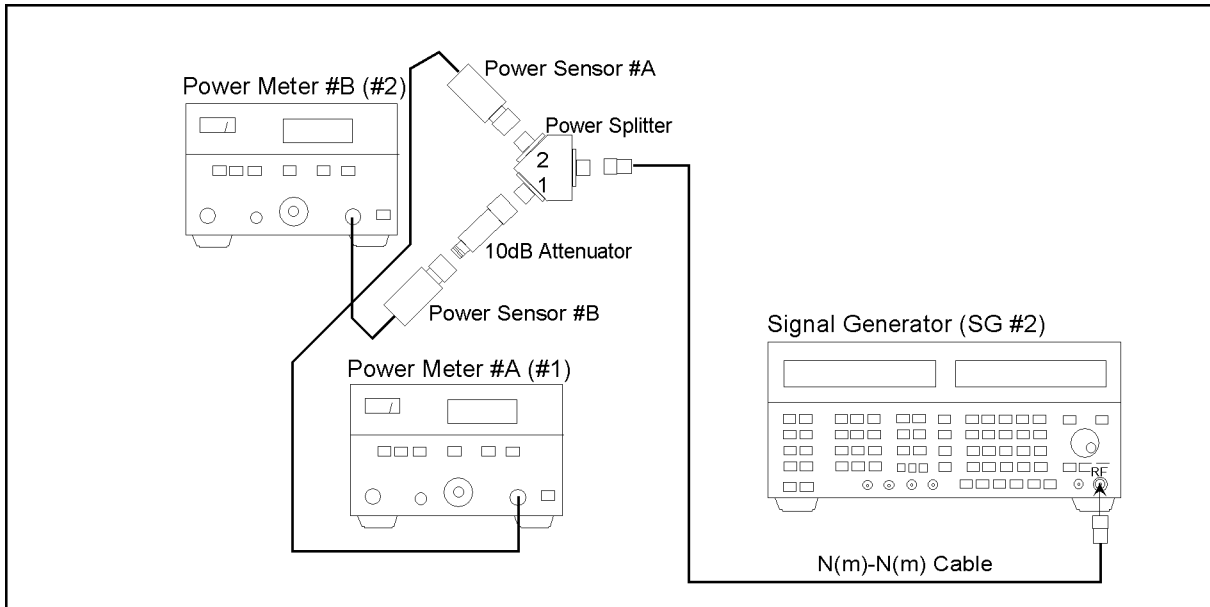

CDS02024

Figure 2-3. Power Splitter Tracking Error Measurement Setup 2

- e. Repeat the step c except for the recording name. Use PMA2(XXX), PMB2(XXX) instead of PMA1(XXX), PMB1(XXX), respectively.
 - f. Calculate the following formula. Note each calculated value as Track(XXX).

$$\text{Track(XXX)} = \{ \text{PMA1(XXX)} - \text{PMB1(XXX)} \} - \{ \text{PMA2(XXX)} - \text{PMB2(XXX)} \} / 2$$
3. Remove the 50Ω termination, and connect the power splitter to the 4352B RF IN connector with a N(m)-N(m) adapter as shown in Figure 2-4.

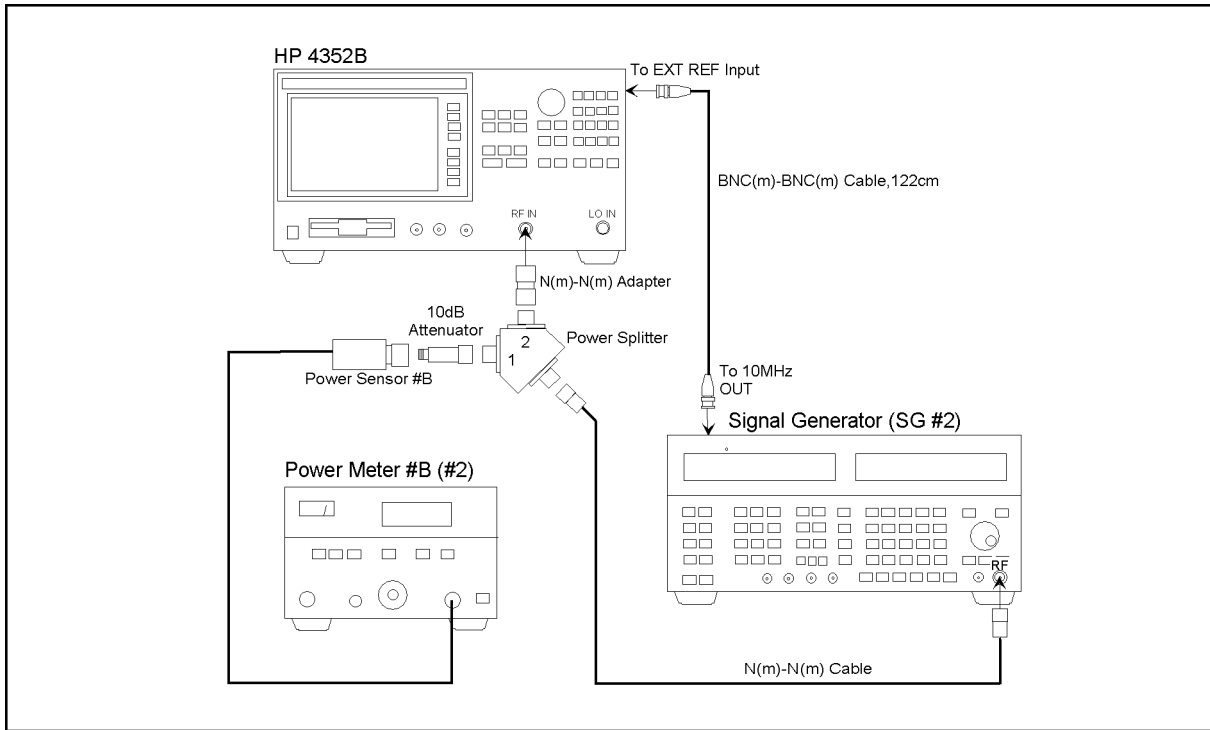

CDS02025

Figure 2-4. RF Power Measurement Accuracy Test Setup 1

Note



Connect the signal generator's 10 MHz frequency reference output to the 4352B EXT REF Input on the rear panel as shown in Figure 2-4. With this configuration, both the signal generators and the 4352B are phased locked to the same reference frequency to obtain a stable measurement.

4. Press **[Preset]** to initialize the 4352B.
5. Press **[Meas]**, **INST TYPE**, **INST TYPE: VCO TESTER** to set the instrument type to Tester Mode.
6. Press **MEAS: RF POWER** to set the measurement item to RF Power.
7. Set the signal generator output frequency to 10 MHz, and turn the signal generator output ON.
8. Adjust the signal generator output level around 6 dBm until the power meter reading is -10 dBm \pm 0.1 dB.
9. Read the 4352B measurement result, and calculate the following formula:

$$\text{Test Result (dB)} = 4352\text{B reading} - (\text{Power Meter reading} - \text{Track}(10\text{M}))$$
 Record the calculated test result on the Performance Test Record.

10. Set the signal generator output frequency in accordance with the following frequencies, and repeat step 8 and step 9.
 - 10 MHz
 - 50 MHz
 - 100 MHz
 - 500 MHz
 - 1 GHz
 - 1.5 GHz
 - 2 GHz
 - 2.5 GHz
 - 3 GHz
11. Set the signal generator output frequency to 50 MHz, and adjust the signal generator output level to around -4 dBm until the power meter reading is -20 dBm \pm 0.1 dB.
12. Read the 4352B measurement result, and calculate the following formula:
 Test Result (dB) = 4352B - (Power Meter reading - Track(50M))
 Record the calculated test result on the Performance Test Record.
13. Turn the signal generator output OFF, and connect the test equipment as shown in Figure 2-5.

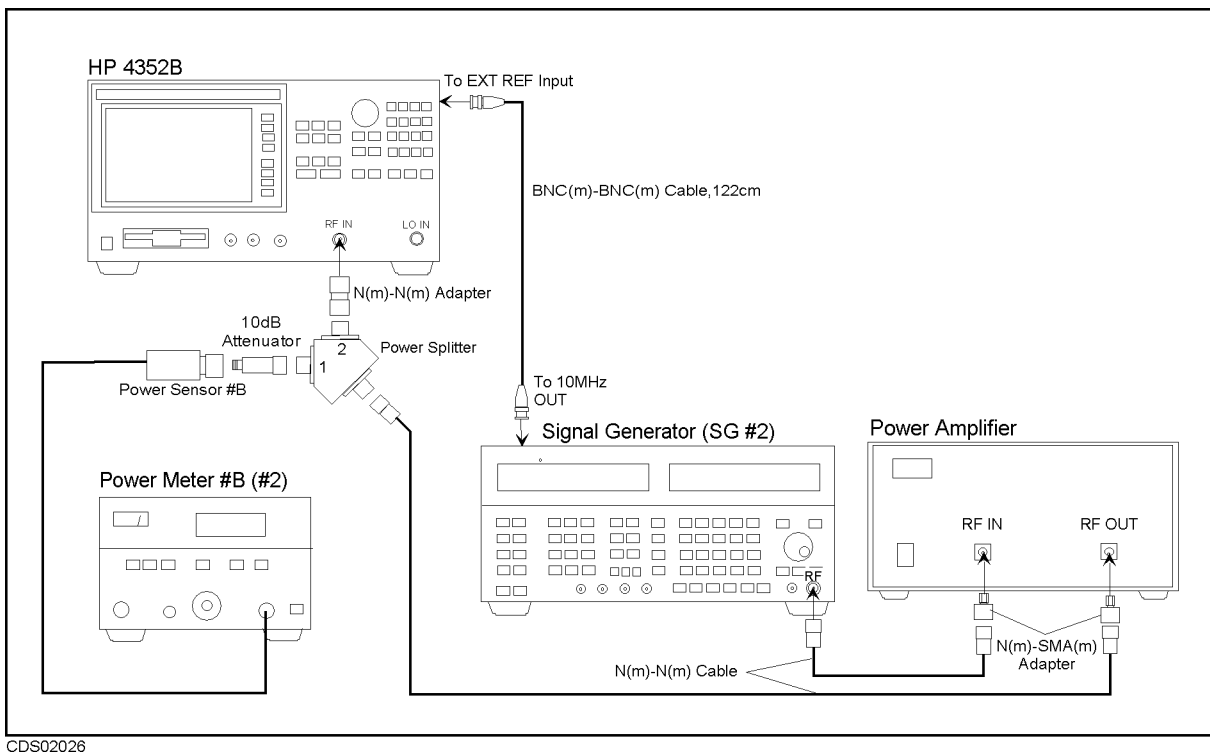

Figure 2-5. RF Power Measurement Accuracy Test Setup 2

14. Set the signal generator output level to -22 dBm, 50 MHz, and turn the signal generator output ON. Adjust the signal generator output level until the power meter reading is 0 dBm \pm 0.1 dB.
15. Read the 4352B measurement result, and calculate the following formula:

Test Result (dB) = 4352B reading - (Power Meter reading - Track(50M))

Record the calculated test result on the Performance Test Record.

16. Turn the signal generator output OFF, and set the signal generator output level to -12 dBm, 50 MHz. Then turn the signal generator output ON.
17. Adjust the signal generator output level until the power meter reading is 10dBm \pm 0.1 dB.
18. Read the 4352B measurement result, and calculate the following formula:

Test Result (dB) = 4352B reading - (Power Meter reading - Track(50M))

Record the calculated test result on the Performance Test Record.

Caution



To prevent damage of the 4352B from an accidentally large signal level input, turn the power amplifier off immediately after this test is completed.

C/N RATIO MEASUREMENT PHASE NOISE TEST

Description

This test verifies the accuracy of the Carrier/Noise ratio measurement in Tester Mode. This test uses the 10 MHz internal reference frequency on the rear panel as the carrier frequency.

Specification

Phase Noise

@1 kHz Offset	100 dBc/Hz
@10 kHz Offset	130 dBc/Hz
@100 kHz Offset	140 dBc/Hz

Test Equipment

BNC cable, 122 cm, 2 ea.	PN 8120-1840
BNC(f)-N(m) adapter, 2 ea.	PN 1250-1476

Procedure

1. Connect the test equipment as shown in Figure 2-6.

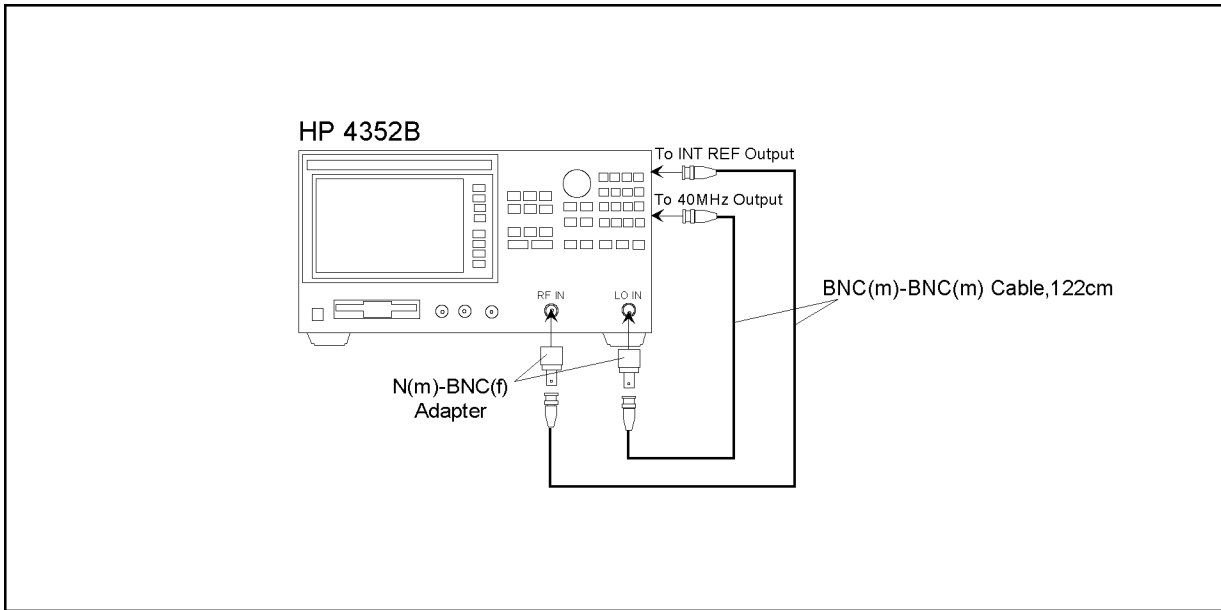

Figure 2-6. C/N Measurement Phase Noise Test Setup

2. Press **[Preset]** to initialize the 4352B.
3. Press **[Meas]**, **INST TYPE**, **INST:TYPE VCO TESTER** to set the instrument type to the Tester Mode.
4. Press **[Meas]**, **CARRIER/NOISE** to set the measurement item to Carrier/Noise ratio.
5. Press **[Bw/Avg]**, **AVERAGING on OFF** to turn the averaging function (AVG=16) ON.

6. Press **Bw/Avg**, **OFFSET FREQ**, and the entry keys to set the offset frequency in accordance with the following list, and record each measurement result on the Performance Test Record.
 - 1 kHz
 - 10 kHz
 - 100 kHz

C/N MEASUREMENT FLATNESS ACCURACY TEST

Description

This test verifies the flatness of the Carrier/Noise ratio measurement in Tester Mode. The mixed signal generated by two signal generators is used as the signal under test (One signal generator is used to make a carrier signal, and the other is used to make a noise signal).

Specification

C/N Measurement Accuracy[†]	
@1 kHz to 1 MHz offset	±2dB
@1 MHz to 10 MHz offset	±4dB

[†](Note that if **NOISE PLL auto WIDE** (CNPLL WIDE) is selected, this accuracy is valid at an offset frequency above 5 kHz.)

Test Equipment

Signal Generator for LO (SG#1)	8664A/8642B
Signal Generator (SG#2)	8664A/8665B
Network Analyzer	8753D
Power Meter	436A
Power Sensor	8482A
Power Divider	11636A
10 dB Fixed Attenuator, 2 ea.	8491A Opt.010, H60
Power Splitter	11667A
Step Attenuator	8496A/G Opt.H60
N(m)-N(m) adapter, 50Ω, 2 ea.	PN 1250-1475
N(m)-N(m) cable, 61 cm, 3 ea.	11500B or part of 11851B
BNC cable, 122 cm, 3 ea.	PN 8120-1840
GPIO Cable	PN 8120-3445

1: Calibration values for attenuation setting of 40 dB at 10 MHz, 1 GHz are required.

2: 11713A is required when using a programmable step attenuator 8496G.

Procedure

1. Connect the power sensor to the power meter. Calibrate the power meter with the power sensor. Set the display unit to dBm.
2. Connect the test equipment as shown in Figure 2-7.

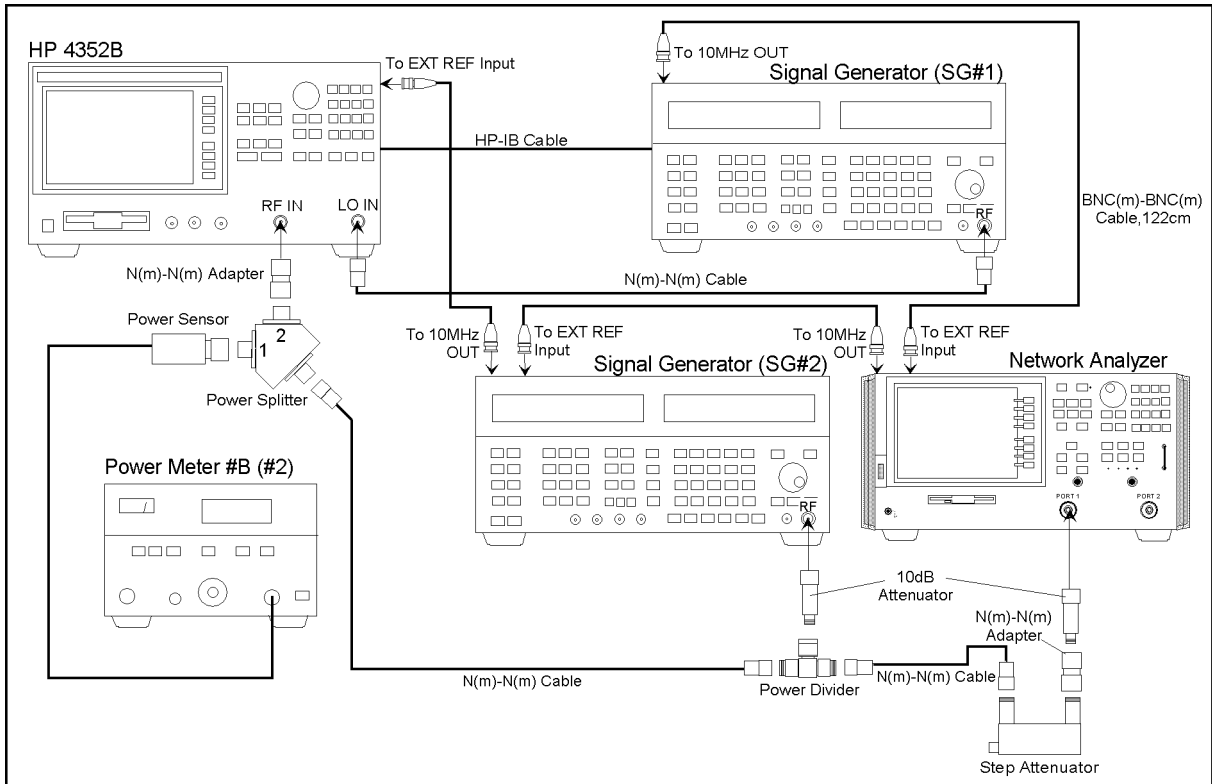

CDS02027

Figure 2-7. C/N Ratio Measurement Accuracy (Flatness) Test Setup

Note



Connect the signal generator's 10 MHz frequency reference output to the 4352B EXT REF Input on the rear panel as shown in Figure 2-8. With this configuration, both the signal generators and the 4352B are phase locked to the same reference frequency to obtain a stable measurement.

Note



In this test, the 4352B uses the signal generator (SG#1) as the first local oscillator. The 4352B automatically controls SG#1 via GPIB by performing the following procedures.

- a. Connect the GPIB cable between the 4352B and the signal generator.
- b. Press **[Local]**, **SYSTEM CONTROLLER**. Then press **SET ADDRESSES**, **ADDRESS: SG** and the entry keys to set the GPIB address of the signal generator (SG#1). (The factory default setting of the signal generator address is 19.)
- c. Press **[RF/LO]**, **SG TYPE**, **[1]**, **[x1]** to set the signal generator type to the 8664A.
- d. Press **[Preset]** to initialize the 4352B. Confirm that the SG#1's GPIB remote indicator is lit.

3. Press **[Preset]** to initialize the 4352B.
4. Press **[Meas]**, **INST TYPE**, **INST TYPE: VCO TESTER** to set the instrument type to Tester Mode.
5. Press **[Meas]**, **CARRIER/NOISE** to set the measurement item to Carrier/Noise ratio.

6. Set the 4352B Measurement Controls as follows:

Control Settings	Keystrokes
RF ATTEN = 0 dB	Sense Range , RF ATTEN , 0 , x1
AVERAGING: ON (AVG= 16)	Bw/Avg , AVERAGING on OFF
C/N APERTURE: MANUAL	System , SERVICE MENU , SERVICE MODES , MISC MENU , C/N APER AUTO man

7. Set SG#2's output frequency to 10 MHz as the carrier signal.
8. Set SG#3's output frequency to 9 MHz as the noise signal.
9. Turn the SG#2 signal output ON, and turn the SG#3 signal output OFF.
10. Adjust the output amplitude of SG#2 until the power meter reading is -10 dBm ±0.1 dB. Then record the power meter reading as PM_carrier(10M).
11. Turn the SG#2 signal output OFF, and turn the SG#3 signal output to ON.
12. Set the step attenuator to 0 dB.
13. Adjust the output amplitude of SG#3 until the power meter reading is -10 dBm ±0.1 dB. Then record the power meter reading as PM_noise (9M).
14. Set the step attenuator to 40 dB.
15. Turn both SG#2 and SG#3 signal outputs ON.
16. Press **Bw/Avg**, **OFFSET FREQ** , **1**, **M/μ** to set the offset frequency of the 4352B Carrier/Noise ratio measurement to 1 MHz.
17. Read the 4352B measurement result, and calculate the following formula:
 Test Result(dB) = 4352B reading - (PM_carrier(10M) - PM_noise(9M) + 40 dB Cal.Value of Step Att.)
 Record the test result on the Performance Test Record.
18. Change the signal generator's (SG#2/SG#3) output frequencies, and the 4352B offset frequency in accordance with the following table. Repeat step 7 through step 17 for each setting.

SG#2 Freq. (Carrier)	SG#3 Freq. (Noise)	4352B Offset Freq.
10 MHz	9 MHz	1 MHz
10 MHz	9.999 MHz	1 kHz
10 MHz	10.001 MHz	1 kHz
10 MHz	11 MHz	1 MHz
1 GHz	0.99 GHz	10 MHz
1 GHz	0.999 GHz	1 MHz
1 GHz	0.999999 GHz	1 kHz
1 GHz	1.000001 GHz	1 kHz
1 GHz	1.001 GHz	1 MHz
1 GHz	1.01 GHz	10 MHz

C/N RATIO MEASUREMENT LINEARITY ACCURACY TEST

Description

This test verifies the linearity of the Carrier/Noise ratio measurement in Tester Mode. The mixed signal generated by two signal generators is used as the signal under test (One signal generator is used to make a carrier signal, and the other is used to make a noise signal).

Specification

C/N Measurement Accuracy[†]

@1 kHz to 1 MHz offset	±2dB
@1 MHz to 10 MHz offset	±4dB

[†](Note that if **NOISE PLL auto WIDE** (CNPLL WIDE) is selected, this accuracy is valid at offset frequency above 5 kHz.)

Test Equipment

Signal Generator for LO (SG#1).....	8664A/8642B
Signal Generator (SG#2)	8664A/8665B
Network Analyzer	8753D
Power Meter	436A
Power Sensor	8482A
Power Divider	11636A
10 dB Fixed Attenuator, 2 ea.	8491A Opt.010, H60
Power Splitter	11667A
Step Attenuator	8496A/G Opt.H60
N(m)-N(m) adapter, 50Ω, 2 ea.	PN 1250-1475
N(m)-N(m) cable, 61 cm, 3 ea.	11500B or part of 11851B
BNC cable, 122 cm, 3 ea.	PN 8120-1840
GPIB Cable	PN 8120-3445

1: Calibration values for attenuation settings of 10 dB through 70 dB at 1 GHz are required.

2: 11713A is required when using a programmable step attenuator 8496G.

Procedure

1. Connect the power sensor to the power meter. Calibrate the power meter with the power sensor. Set the display unit to dBm.
2. Connect the test equipment as shown in Figure 2-8.

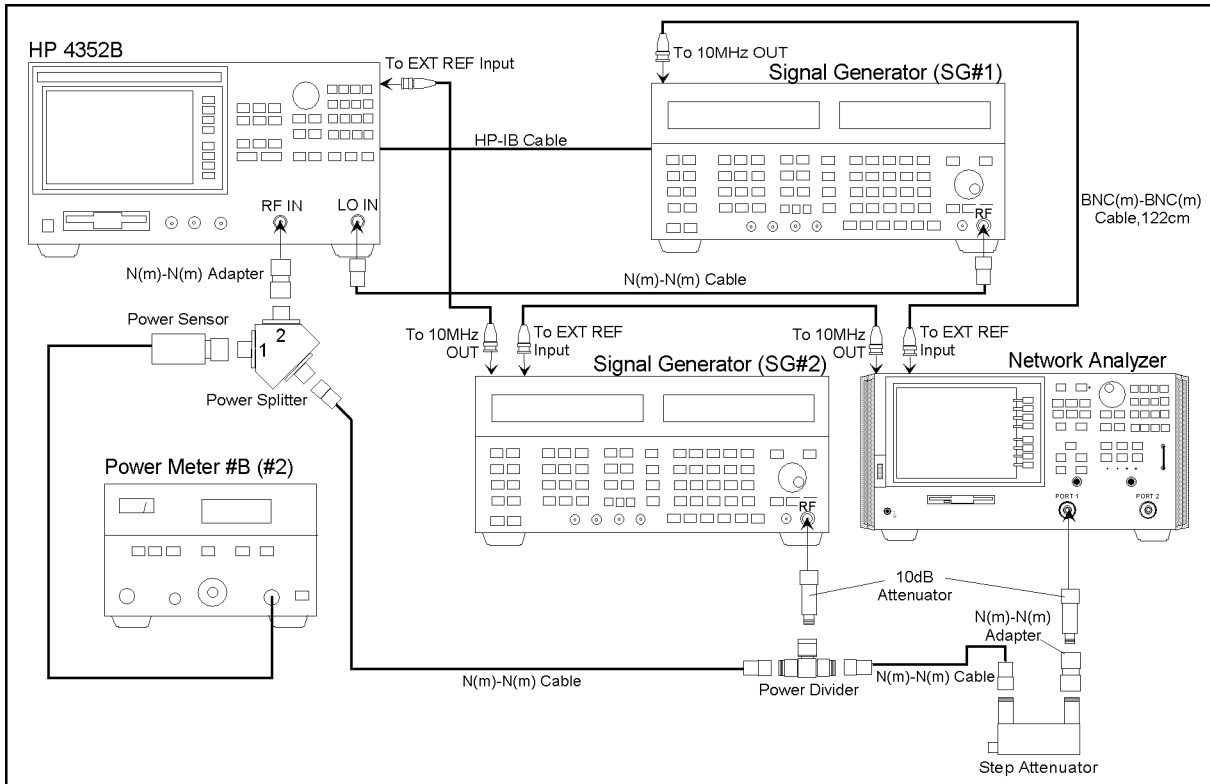

CDS02027

Figure 2-8. C/N Ratio Measurement Accuracy (Linearity) Test Setup

Note



Connect the signal generator's 10 MHz frequency reference output to the 4352B EXT REF Input on the rear panel as shown in Figure 2-8. With this configuration, both the signal generators and the 4352B are phase locked to the same reference frequency to obtain a stable measurement.

Note



In this test, the 4352B uses the signal generator (SG#1) as the first local oscillator. The 4352B automatically controls SG#1 via GPIB by performing the following procedures.

- a. Connect the GPIB cable between the 4352B and the signal generator.
- b. Press **[Local]**, **SYSTEM CONTROLLER**. Then press **SET ADDRESSES**, **ADDRESS: SG** and the entry keys to set the GPIB address of the signal generator (SG#1). (The factory default setting of the signal generator address is 19.)
- c. Press **[RF/LO]**, **SG TYPE**, **[1]**, **[x1]** to set the signal generator type to the 8664A.
- d. Press **[Preset]** to initialize the 4352B. Confirm that the SG#1's GPIB remote indicator is lit.

3. Press **[Preset]** to initialize the 4352B.
4. Press **[Meas]**, **INST TYPE**, **INST TYPE: VCO TESTER** to set the instrument type to Tester Mode.
5. Press **[Meas]**, **CARRIER/NOISE** to set the measurement item to Carrier/Noise ratio.

6. Set the 4352B Measurement Controls as follows:

Control Settings	Keystrokes
RF ATTEN = 0 dB	Sense Range , RF ATTEN , 0, x1
AVERAGING: ON (AVG=16)	Bw/Avg , AVERAGING on OFF
NOISE ATTEN = 30 dB	Sense Range , NOISE ATTEN , 3, 0, x1
C/N APERTURE: MANUAL	System , SERVICE MENU , MISC MENU , C/N APER AUTO man

7. Set SG#2's output frequency to 1.0001 GHz as the carrier signal.
8. Set SG#3's output frequency to 1.0000 GHz as the noise signal.
9. Turn the SG#2 signal output ON, and turn the SG#3 signal output OFF.
10. Adjust the output amplitude of SG#2 until the power meter reading is -10 dBm ±0.1 dB. Then record the power meter reading as PM_carrier.
11. Turn the SG#2 signal output OFF, and turn the SG#3 signal output to ON.
12. Set the step attenuator to 0 dB.
13. Adjust the output amplitude of SG#3 until the power meter reading is - 20 dBm ±0.1 dB. Then record the power meter reading as PM_noise (0dB).
14. Turn both SG#2 and SG#3 signal outputs ON.
15. Press **Bw/Avg**, **OFFSET FREQ** , 1, 0, 0, **k/m** to set the offset frequency of the 4352B Carrier/Noise ratio measurement to 100 kHz.
16. Read the 4352B measurement result, and calculate the following formula:
 Test Result(dB) = 4352B reading - (PM_carrier - PM_noise(0dB))
 Record the test result on the Performance Test Record.
17. Change the step attenuator setting and the 4352B Noise Attenuator setting in accordance with the following list. Calculate the following formula, and record each test result on the Performance Test Record.
 Test Result(dB) = 4352B reading - (PM_carrier - PM_noise(each attenuator) + Calibrated Value of Step Attenuator)

Attenuator Setting	4352B NOISE ATTEN Setting	C/N ratio
10 dB	20 dB	20 dB
20 dB	10 dB	30 dB
30 dB	0 dB	40 dB
40 dB	0 dB	50 dB
50 dB	0 dB	60 dB
60 dB	0 dB	70 dB
70 dB	0 dB	80 dB

FM DEVIATION TEST

Description

This test verifies the accuracy of the FM deviation measurement. This test uses the FM signal from function generator with an AM/FM Test Source.

Specification

Measurement Range	0 to 200 kHz
Deviation Resolution	4 digits
Deviation Accuracy	
@1kHz FM, 2kHz range, 23±10°C	(±2% of reading + 0.5% of meas.range)
@1kHz FM, 2kHz range, 0 to 40°C	(±8% of reading + 2.0% of meas.range)
@1kHz FM, 20, 200 kHz range, 23±10°C	(±2% of reading + 0.1% of meas.range)
@1kHz FM, 20, 200 kHz range, 0 to 40°C	(±8% of reading + 0.4% of meas.range)

Test Equipment

Signal Generator for LO (SG#1).....	8664A/8642B
Function Generator	3325A
AM/FM Test Source	11715A
N(m)-N(m) cable, 61 cm.	11500B or part of 11851B
BNC cable; 122 cm, 5 ea.	PN 8120-1840
N(m)-BNC(f) adapter.	PN 1250-1476
GPIB Cable	PN 8120-3445

Procedure

1. Connect the test equipment as shown in Figure 2-9.

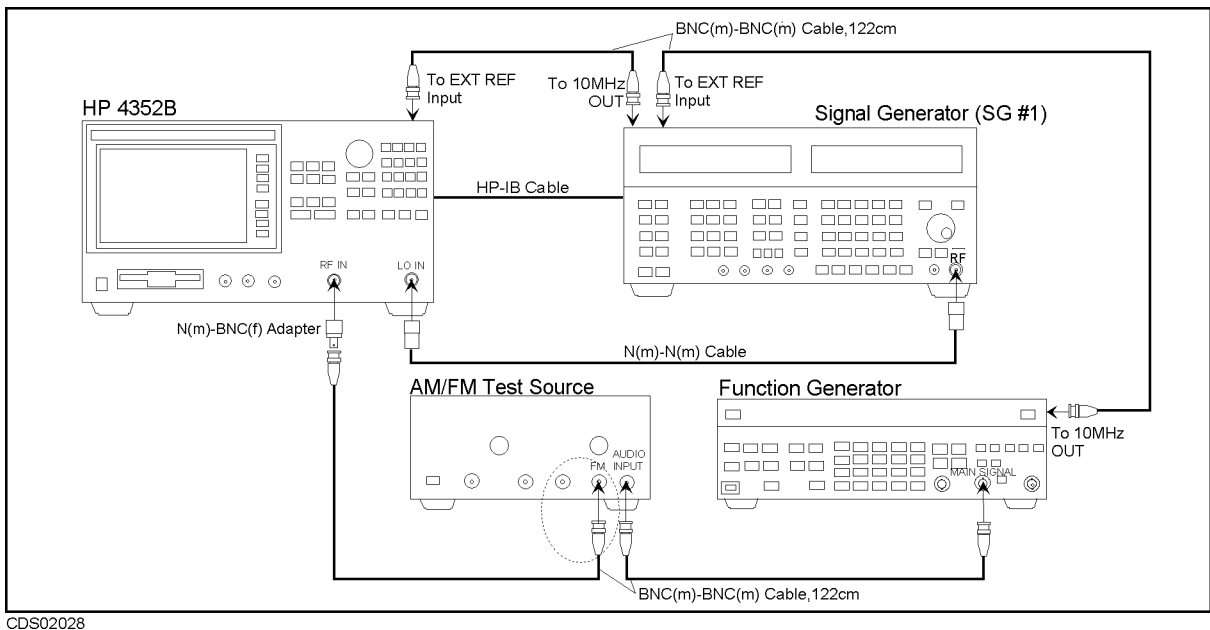

Figure 2-9. FM Deviation Accuracy Test Setup 1

Note

Connect the signal generator's 10 MHz frequency reference output to both the 4352B EXT REF Input on the rear panel and the function generator EXT REF Input on the rear panel as shown in Figure 2-8. With this configuration, the signal generator, the function generator, and the 4352B are phase locked to the same reference frequency to obtain a stable measurement.

Note

In this test, the 4352B uses the signal generator as the first local oscillator. The 4352B automatically controls the signal generator via GPIB by performing the following procedures.

- a. Connect the GPIB cable between the 4352B and the signal generator.
 - b. Press **[Local]**, **SYSTEM CONTROLLER**. Then press **SET ADDRESSES**, **ADDRESS: SG** and the entry keys to set the GPIB address of the signal generator. (The factory default setting of the signal generator address is 19.)
 - c. Press **[RF/LO]**, **SG TYPE**, **[1]**, **[x1]** to set the signal generator type to the 8664A.
 - d. Press **[Preset]** to initialize the 4352B. Confirm that the signal generator's GPIB remote indicator is lit.
-

2. Set the Test Mode of AM/FM Test Source to FM.
3. Set the function generator's output to 1 kHz.
4. Press **[Preset]** to initialize the 4352B.
5. Press **[Meas]**, **INST TYPE**, **INST TYPE: VCO TESTER** to set the instrument type to Tester Mode.
6. Press **[Meas]**, **FREQUENCY** to set the measurement item to Frequency.
7. Adjust the AM/FM Test Source's CARRIER FREQUENCY TUNE knob until the 4352B reading is 400 MHz \pm 0.1 MHz. Keep this knob position until this test is completed.
8. Press **[Meas]**, **FM DEVIATION** to set the measurement item to FM deviation.
9. Perform the following steps to check the 200 kHz range of the FM deviation measurement.
 - a. Press **[Sense Range]**, **FM DEV RANGE**, **FM DEV RNG 200 kHz** to set the FM deviation range to 200 kHz.
 - b. Adjust the function generator's amplitude (around 0 dBm) until the 4352B reading is within the range of 199 kHz_{rms} to 200 kHz_{rms}, and note the 4352B reading as FM_REF.
 - c. Connect the test equipment as shown in Figure 2-10.

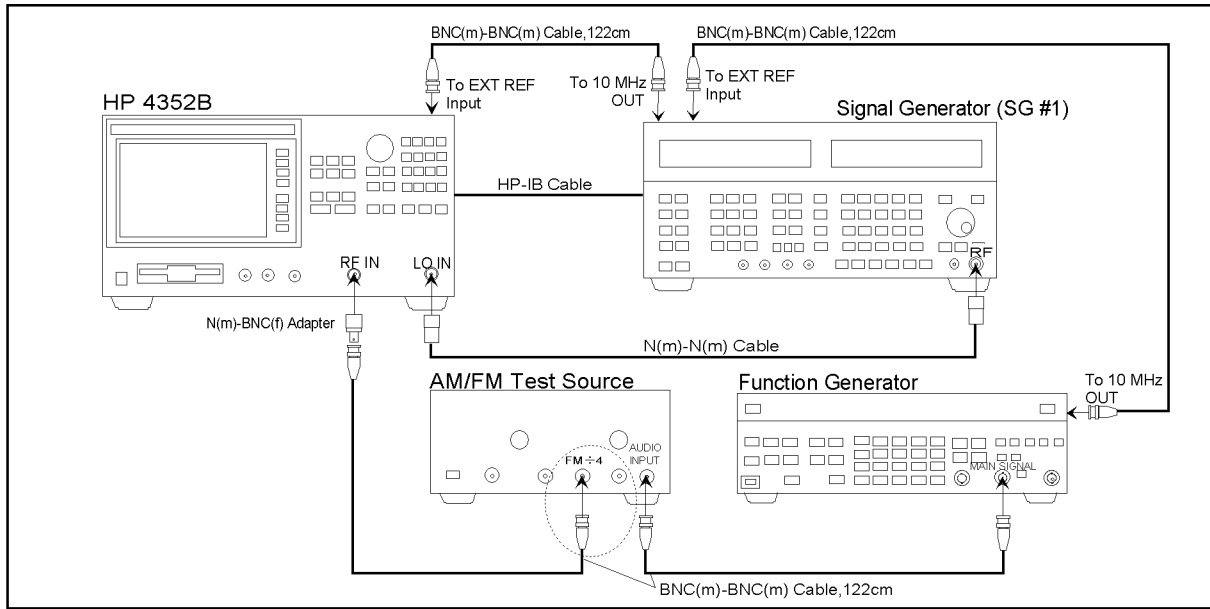

CDS02029

Figure 2-10. FM Deviation Accuracy Test Setup 2

- d. Confirm that the 4352B reading is approximately 50 kHz_{rms}, and note the 4352B reading as FM_TEST.
 - e. Calculate the following formula, and record the 200 kHz range test result on the Performance Test Record.

$$\text{Test Result (\%REL)} = \text{FM_TEST} / \text{FM_REF} * 100$$
10. Perform the following steps to check the 20 kHz range of the FM deviation measurement.
- a. Remove the BNC cable from FM output on the AM/FM Test Source, and connect it to the FM OUTPUT on the AM/FM Test Source as shown in Figure 2-11.

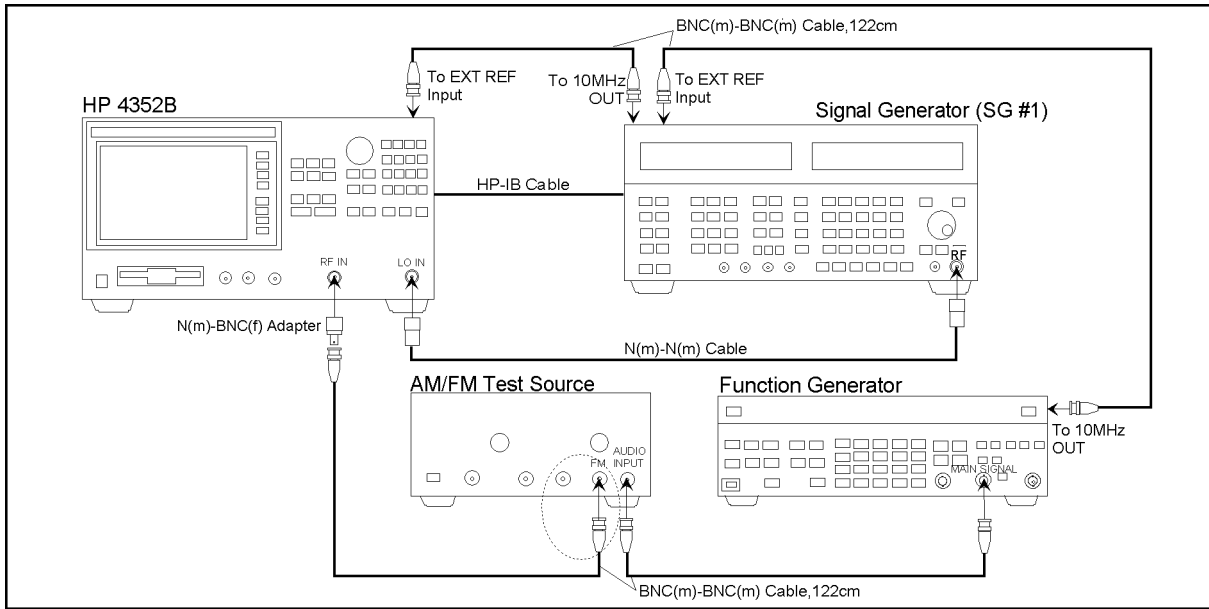

CDS02028

Figure 2-11. FM Deviation Accuracy Test Setup 3

- b. Press **Sense Range**, **FM DEV RANGE**, **FM DEV RNG 200 kHz** to set the FM deviation range to 200 kHz.
- c. Adjust the function generator's amplitude (around -8 dBm) until the 4352B reading is $80 \text{ kHz}_{\text{RMS}} \pm 1 \text{ kHz}_{\text{RMS}}$, and note the 4352B reading as FM_REF.
- d. Remove the BNC cable from the FM/4 output on the AM/FM Test Source, and connect it to the FM OUTPUT on the AM/FM Test Source as shown in Figure 2-12.

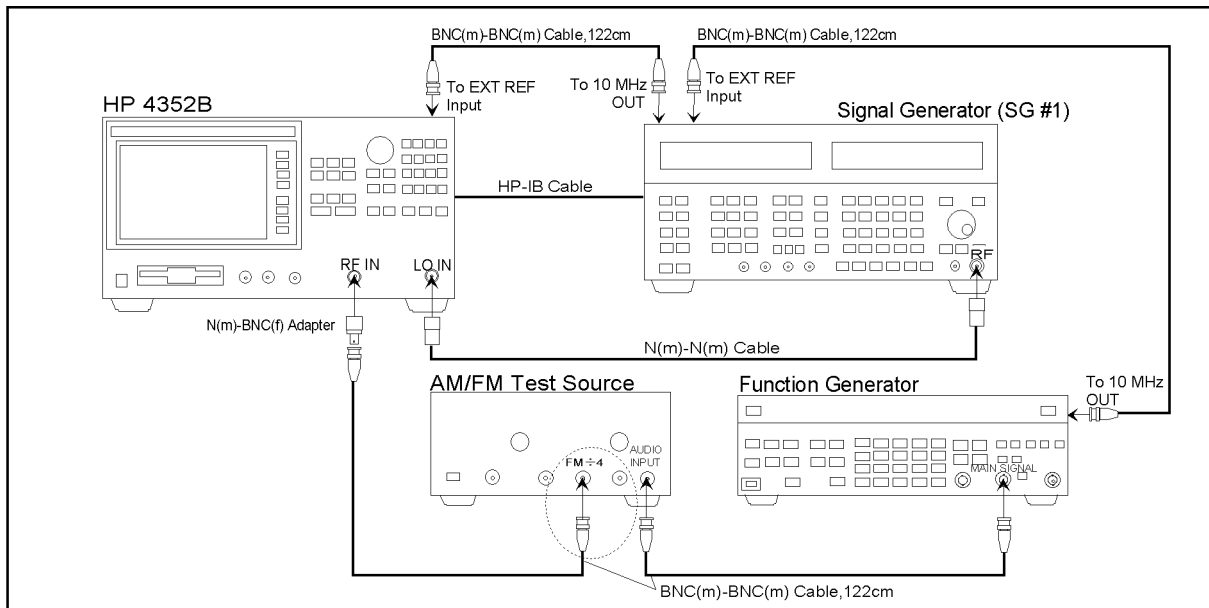

CDS02029

Figure 2-12. FM Deviation Accuracy Test Setup 4

- e. Press **Sense Range**, **FM DEV RANGE**, **20 kHz** to set the FM deviation range to 20 kHz.

- f. Confirm that the 4352B reading is approximately 20 kHz_{rms}, and note the 4352B reading as FM_TEST.
- g. Calculate the following formula, and record the 20 kHz range test result on the Performance Test Record.

$$\text{Test Result (\%REL)} = \text{FM_TEST} / \text{FM_REF} * 100$$

- 11. Perform the following steps to check the 2 kHz range of the FM deviation measurement.
 - a. Remove the BNC cable from FM output on the AM/FM Test Source, and connect it to the FM OUTPUT on the AM/FM Test Source as shown in Figure 2-13.

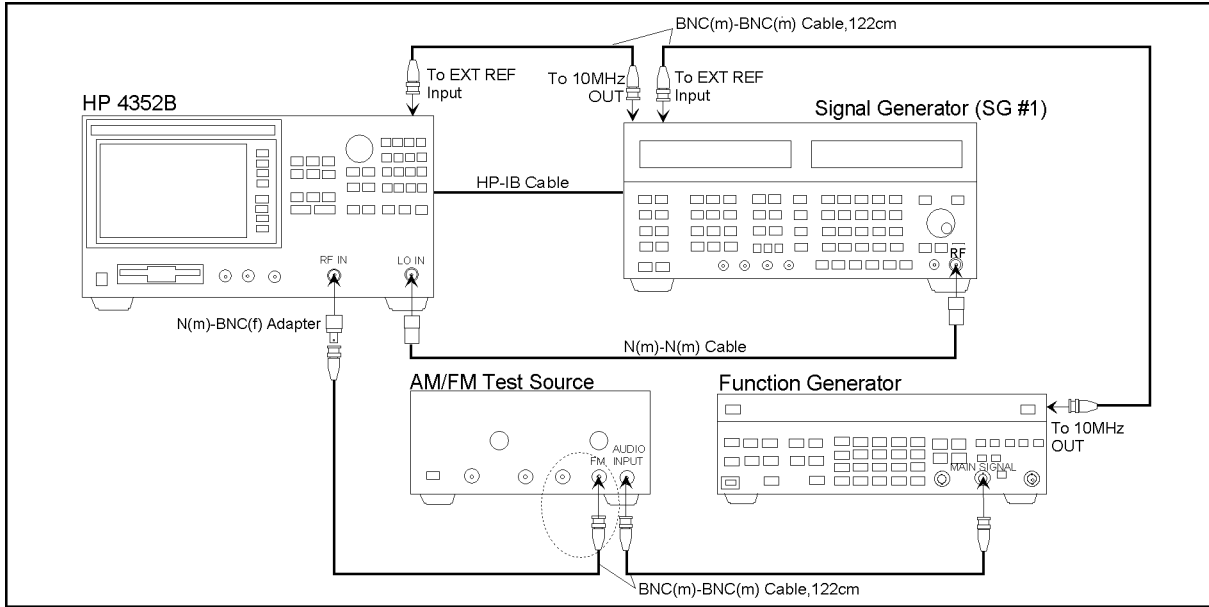

CDS02028

Figure 2-13. FM Deviation Accuracy Test Setup 5

- b. Press **Sense Range**, **FM DEV RANGE**, **20 kHz** to set the FM deviation range to 20 kHz.
- c. Adjust the function generator's amplitude (around -28 dBm) until the 4352B reading is 8 kHz_{rms} ± 0.1 kHz_{rms}, and note the 4352B reading as FM_REF.
- d. Connect the test equipment as shown in Figure 2-14.

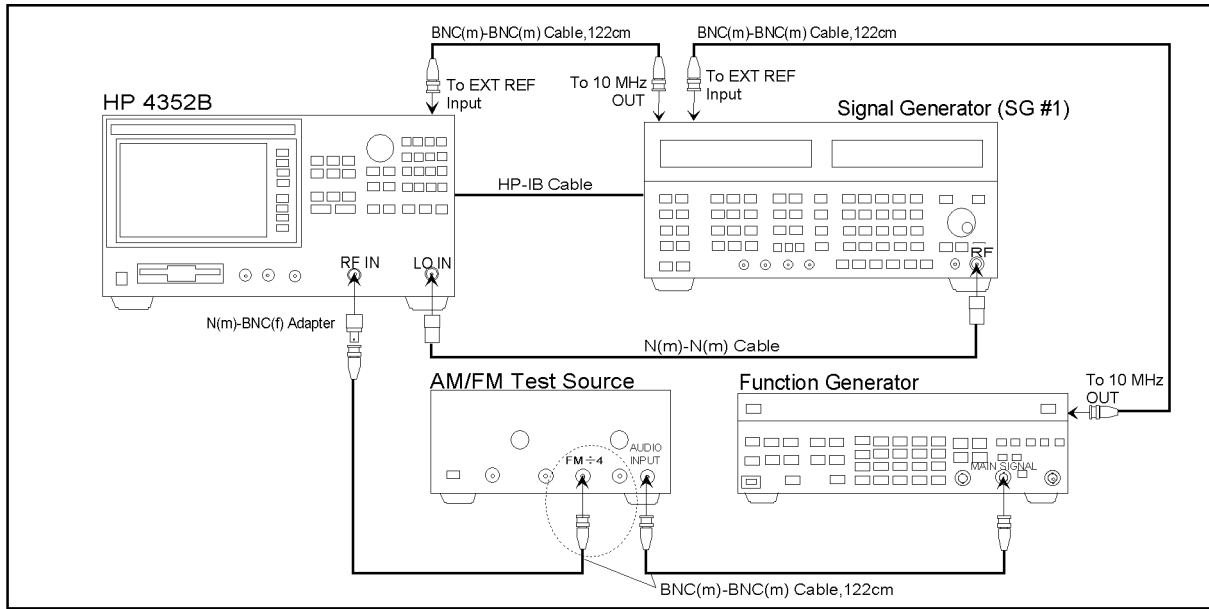

CDS02029

Figure 2-14. FM Deviation Accuracy Test Setup 6

- e. Press **Sense Range**, **FM DEV RANGE**, **2 kHz** to set the FM deviation range to 2 kHz.
- f. Confirm that the 4352B reading is approximately 2 kHz_{rms}, and note the 4352B reading as FM_TEST.
- g. Calculate the following formula, and record the 2 kHz range test result on the Performance Test Record.

$$\text{Test Result (\%REL)} = \text{FM_TEST} / \text{FM_REF} * 100$$

SPECTRUM MEASUREMENT RELATIVE LEVEL ACCURACY TEST

Description

This test verifies the relative level accuracy of the spectrum measurement in Analyzer mode. The mixed signal generated by two signal generators is used as the signal under test.

Specification

Relative Level Accuracy

Ratio of -10 dBm to -60 dBm during one sweep, attenuation=0 dB
..... ±1.5dB

Test Equipment

Signal Generator for LO (SG#1)	8664A/8642B
Signal Generator (SG#2)	8664A/8665B
Network Analyzer	8753D
Power Meter	436A
Power Sensor	8482A
Power Divider	11636A
10 dB Fixed Attenuator, 2 ea.	8491A Opt.H60
Power Splitter	11667A
Step Attenuator	8496A/G Opt.H60
N(m)-N(m) adapter, 50Ω, 2 ea.	PN 1250-1475
N(m)-N(m) cable, 61 cm, 3 ea.	11500B or part of 11851B
BNC cable; 122 cm, 3 ea.	PN 8120-1840
GPIB Cable	PN 8120-3445

1: Calibration value for attenuation setting of 50 dB at 1 GHz is required.

Procedure

1. Connect the power sensor to the power meter. Calibrate the power meter with the power sensor. Set the display unit to dBm.
2. Connect the test equipment as shown in Figure 2-15.

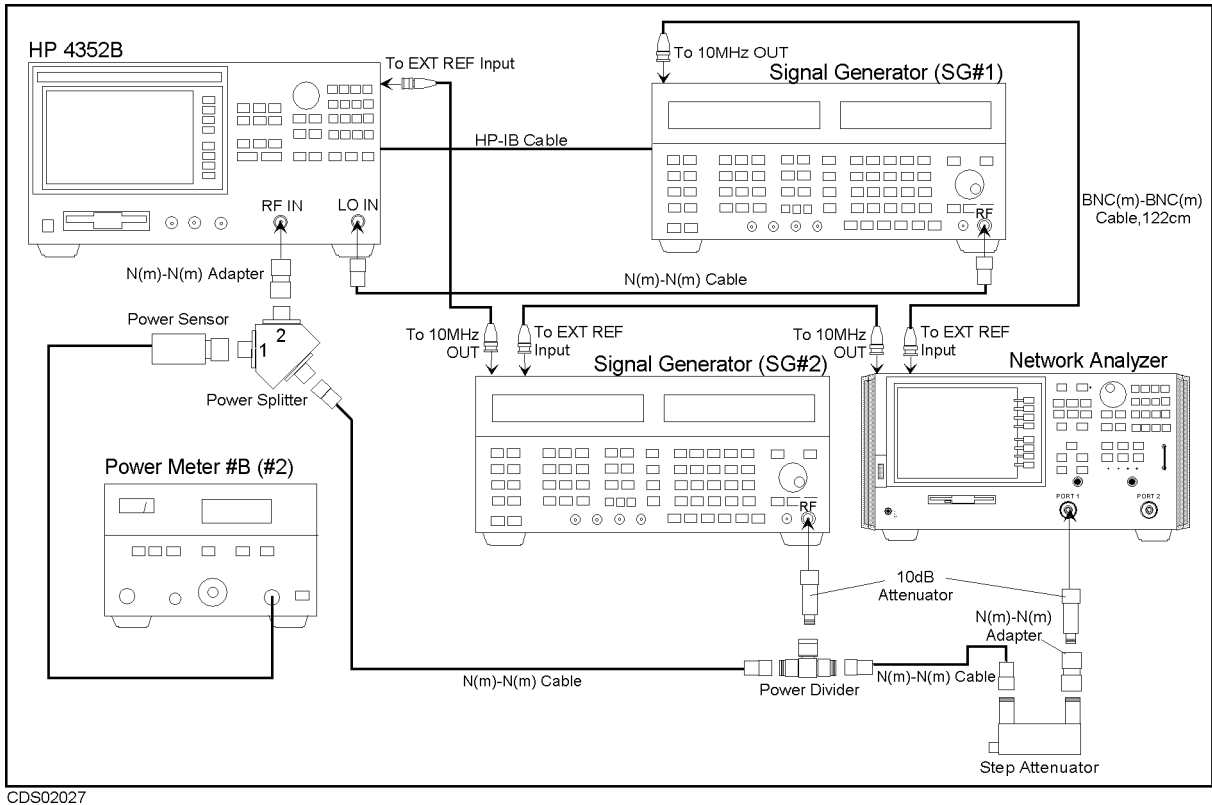

Figure 2-15. Relative Level Accuracy Test Setup

Note



Connect the signal generator's 10 MHz frequency reference output to the 4352B EXT REF Input on the rear panel as shown in Figure 2-8. With this configuration, both the signal generators and the 4352B are phase locked to the same reference frequency to obtain a stable measurement.

Note



In this test, the 4352B uses the signal generator (SG#1) as the first local oscillator. The 4352B automatically controls SG#1 via GPIB by performing the following procedures.

- a. Connect the GPIB cable between the 4352B and the signal generator.
- b. Press **[Local]**, **SYSTEM CONTROLLER**. Then press **SET ADDRESSES**, **ADDRESS: SG** and the entry keys to set the GPIB address of the signal generator (SG#1). (The factory default setting of the signal generator address is 19.)
- c. Press **[RF/LO]**, **SG TYPE**, **[1]**, **[x1]** to set the signal generator type to the 8664A.
- d. Press **[Preset]** to initialize the 4352B. Confirm that the SG#1's GPIB remote indicator is lit.

3. Press **[Preset]** to initialize the 4352B.
4. Press **[Meas]**, **INST TYPE**, **VCO ANALY** to set the instrument type to Analyzer mode.
5. Press **[Meas]**, **SPECTRUM** to set the measurement item to Spectrum.

6. Set the 4352B Measurement Controls as follows:

Control Settings

RF ATTEN = 0 dB

CENTER = 1 GHz

SPAN = 10 MHz

RES BW = 1 kHz

Keystrokes

(Sense Range), RF ATTEN, (0), (x1)

(Menu), SWEEP, CENTER, (1), (G/n)

SPAN, (1), (0), (M/μ)

(Bw/Avg), RES BW, (1), (k/m)

7. Set the signal generator (SG#2) output to 1 GHz, 12 dBm.
8. Set the signal generator (SG#3) output to 0.999 GHz, 12 dBm.
9. Turn the SG#2 signal output ON, and turn the SG#3 signal output OFF.
10. Record the power meter reading as PM1.
11. Turn the SG#1 signal output OFF, and turn the SG#2 signal output ON.
12. Set the step attenuator to 0 dB.
13. Record the power meter reading as PM2.
14. Turn both SG#2 and SG#3 signal outputs ON.
15. Set the step attenuator to 50 dB.
16. Press (Trigger), SINGLE to make a measurement. Wait until a sweep is completed.
17. Press (Menu), MKR SEARCH, MAX to move the marker to the SG#2 frequency point. Note the 4352B reading as SA1. Press SEARCH: PEAK, NEXT PEAK to move the marker to the SG#3 frequency point. Note the 4352B reading as SA2.
18. Calculate the following formula:
Test Result(dB) = (SA1 - SA2) - (PM1 - PM2 - Cal.value of Step attenuator(50 dB @ 1GHz))
Record the test result on the Performance Test Record.
19. Set the SG#3 output frequency in accordance with the following list, and repeat steps 16 through 18.
- 0.998 GHz
 - 0.997 GHz
 - 0.996 GHz
 - 0.995 GHz
 - 1.001 GHz
 - 1.002 GHz
 - 1.003 GHz
 - 1.004 GHz
 - 1.005 GHz

FREQUENCY TRANSIENT FREQUENCY ACCURACY TEST

Description

This test verifies the frequency accuracy of the Frequency Transient measurement in Analyzer mode.

Specification

Frequency Accuracy

Measurement Range = RF MAX – RF MIN

When Measurement range > 30MHz,

..... $\pm([\text{Integer of } \{ \text{RF MAX [MHz]} / 192 + 1 \}] \times 192 \times 0.1\% + 0.2)$ [MHz]

When Measurement range \leq 30MHz,

When RF MAX \geq 40MHz $\pm(\text{measurement range} \times 0.1\% + \text{time base accuracy of external signal source used})$

When RF MAX < 40MHz .. $\pm(30\text{kHz} + \text{time base accuracy of external signal source used})$

Test Equipment

Signal Generator (SG#1)	8664A/8642B
Signal Generator (SG#2)	8664A/8665B
N(m)-N(m) cable, 61 cm, 2 ea.	11500B or part of 11851B
BNC cable, 122 cm, 2 ea.	PN 8120-1840
GPIB Cable	PN 8120-3445

Procedure

1. Connect the test equipment as shown in Figure 2-16.

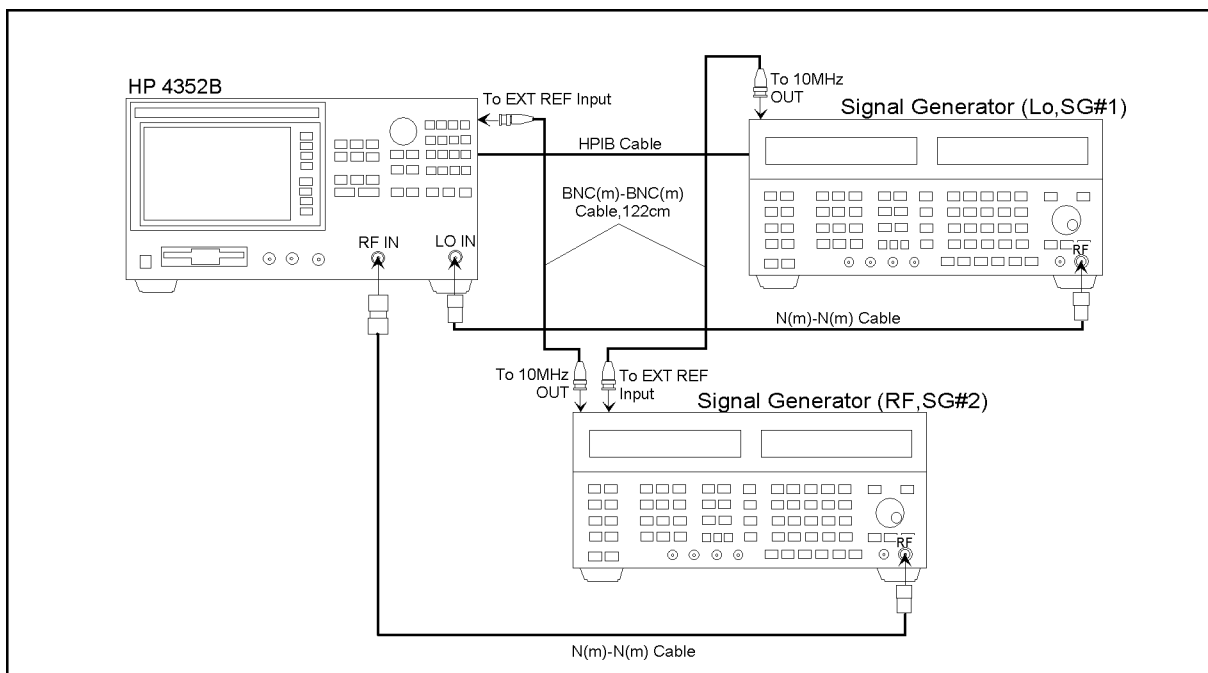

CDS02030

Figure 2-16. Frequency Transient Frequency Accuracy Setup

2. Press **Preset** to initialize the 4352B.
3. Press **Meas**, **INST TYPE**, **VCO ANALY** to set the instrument type to Analyzer mode.
4. Press **Meas**, **RF TRANSIENT** to set the measurement item to Frequency Transient.
5. Set the output level from the signal generator (SG#2) to 0 dBm.
6. Set the signal generator (SG#2) output frequency to 880 MHz.
7. Press **Sense Range**, **RF MAX FREQ**, **9**, **6**, **0**, **M/μ** to set the maximum frequency for RF transient measurement to 960 MHz.
8. Press **Sense Range**, **RF MIN FREQ**, **3**, **2**, **0**, **M/μ** to set the minimum frequency for RF transient measurement to 320 MHz.
9. Press **Trigger**, **SINGLE** to make one sweep measurement.
10. Press **Menu**, **MKR SEARCH**, **MAX** to move the marker to the maximum frequency point on the trace. Record the 4352B marker reading on the Performance Test Record.
11. Press **MIN** to move the marker to the minimum frequency point on the trace. Record the 4352B marker reading on the Performance Test Record.
12. Set the output frequency of the signal generator (SG#2) and the maximum/minimum frequency for RF transient measurement in accordance with the following table. (Refer to the above setting procedures as reference.) Record the 4352B marker reading (each maximum/minimum frequency point) on the Performance Test Record.

SG#2 Output	RF TRANS MAX FREQ	RF TRANS MIN FREQ
880 MHz	884 MHz	854 MHz
880 MHz	880.3 MHz	878.3 MHz
25 MHz	30 MHz	10 MHz

DC POWER VOLTAGE ACCURACY TEST

Description

This test verifies the accuracy of the DC POWER output voltage. This test uses a multimeter to measure the actual DC POWER voltage.

Specification

DC Power Voltage

Voltage Range 0 to +15.5 V (50 mA max.), variable in 1 mV steps

Setting Accuracy

@23±10°C ±(0.2% + 2 mV)

@0 to 40°C ±(0.6% + 6 mV)

Test Equipment

Multimeter 3458A

BNC Cable, 61 cm PN 8120-1839

Dual Banana-BNC(f) adapter PN 1251-2277

Procedure

1. Connect the test equipment as shown in Figure 2-17.

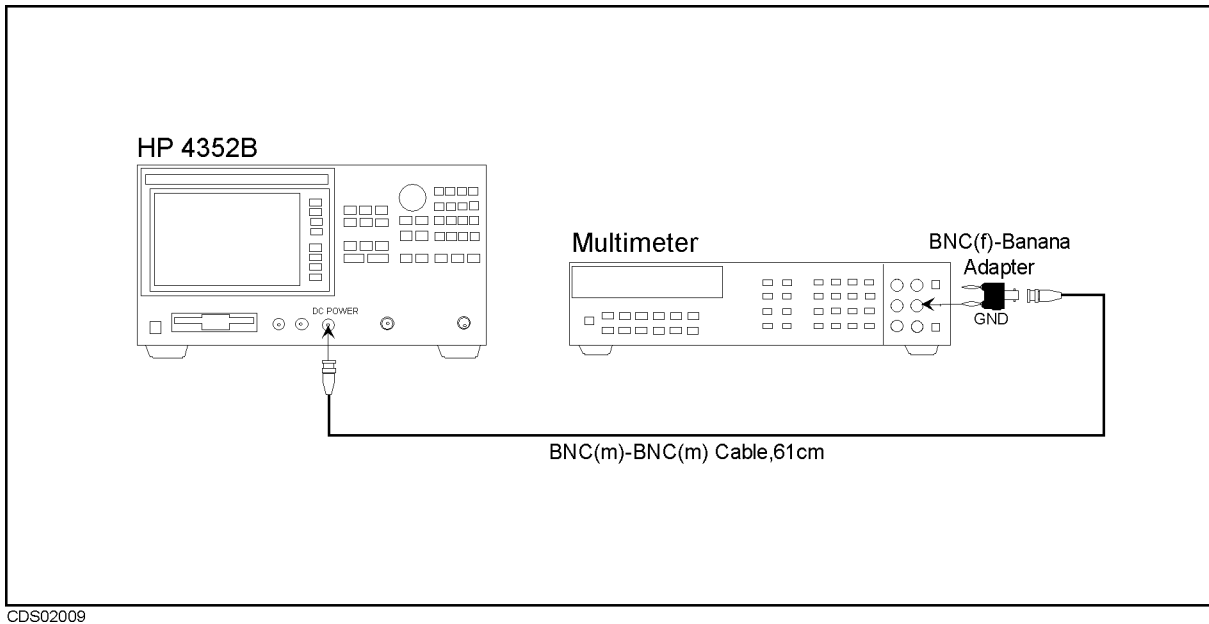

Figure 2-17. DC Power Voltage Accuracy Test Setup

2. Set the multimeter to the DCV measurement mode.
3. Press **Preset** to initialize the 4352B.
4. Press **DC Power**, **POWER VOLTAGE**, **0**, **x1** to set the DC POWER to 0 V.

5. Press **OUTPUT on OFF** to output the DC POWER voltage.
6. Record the multimeter reading on the Performance Test Record.
7. Press **DC Power**, **POWER VOLTAGE**, and the entry keys to set the DC POWER voltage in accordance with the following list. Subtract each DC Power voltage setting value from each multimeter reading, and record the calculated value on the Performance Test Record.
 - 1.0 V
 - 2.5 V
 - 5.0 V
 - 7.5 V
 - 10.0 V
 - 12.5 V
 - 15.0 V
 - 15.5 V

DC CONTROL VOLTAGE ACCURACY TEST

Description

This test verifies the accuracy of the DC CONTROL output voltage. This test uses a multimeter to measure the actual DC CONTROL voltage.

Specification

Voltage Range 0 to 20 V (20 mA max.), variable in 100 μ V steps
with option 001 -15 to 35 V (20 mA max.), variable in 100 μ V steps

Setting Accuracy

@23 \pm 10°C

-15 V to -0.0001 V $\pm\{(\text{setting} + 15 \text{ V}) \times 0.1 \% + 5 \text{ mV}\}$

0 V to 20 V $\pm(\text{setting} \times 0.1 \% + 2 \text{ mV})$

20.0001 V to 35 V $\pm\{(\text{setting} - 15 \text{ V}) \times 0.1 \% + 5 \text{ mV}\}$

Test Equipment

Multimeter 3458A
BNC Cable, 61 cm PN 8120-1839
Dual Banana-BNC(f) adapter PN 1251-2277

Procedure

1. Connect the test equipment as shown in Figure 2-18.

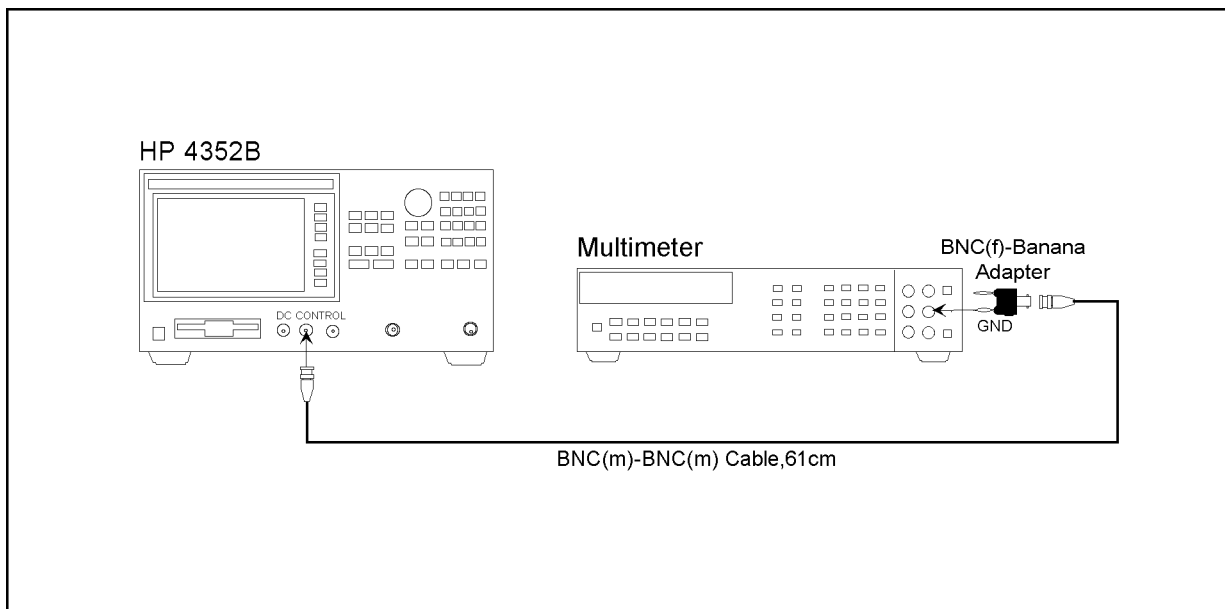

CDS02010

Figure 2-18. DC Control Voltage Accuracy Test Setup

2. Set the multimeter to the DCV measurement mode.
3. Press **[Preset]** to initialize the 4352B.

4. Press **DC Control**, **CTRL VOLTAGE**, **0**, **ⓧ** to set the DC CONTROL to 0 V.
5. Press **OUTPUT on OFF** to output the DC CONTROL voltage.
6. Record the multimeter reading on the Performance Test Record.
7. Press **DC Control**, **CTRL VOLTAGE**, and the entry keys to set the DC CONTROL voltage in accordance with the following list. Subtract each DC CONTROL voltage setting value from each multimeter reading, and record the calculated value on the Performance Test Record.
 - -15 V (opt.001 only)
 - -1 V (opt.001 only)
 - 1.0 V
 - 1.2 V
 - 5.0 V
 - 10.0 V
 - 15.0 V
 - 20.0 V
 - 21 V (opt.001 only)
 - 35 V (opt.001 only)

MOD OUT LEVEL ACCURACY TEST

Description

This test verifies the accuracy of the MOD OUT output level. This test uses a multimeter to measure the actual MOD OUT level.

Specification

Frequency	1 kHz (Fixed)
Level	
@ OPEN load	0 to 1 V _{rms} , variable in 1 mV _{rms} steps
Setting Accuracy	
@ OPEN load, 23±10°C	±(0.5% + 1 mV _{rms})
@ OPEN load, 0 to 40°C	±(1.5% + 3 mV _{rms})

Test Equipment

Multimeter	3458A
BNC Cable, 61 cm	PN 8120-1839
Dual Banana-BNC(f) adapter	PN 1251-2277

Procedure

1. Change the cable connection as shown in Figure 2-19.

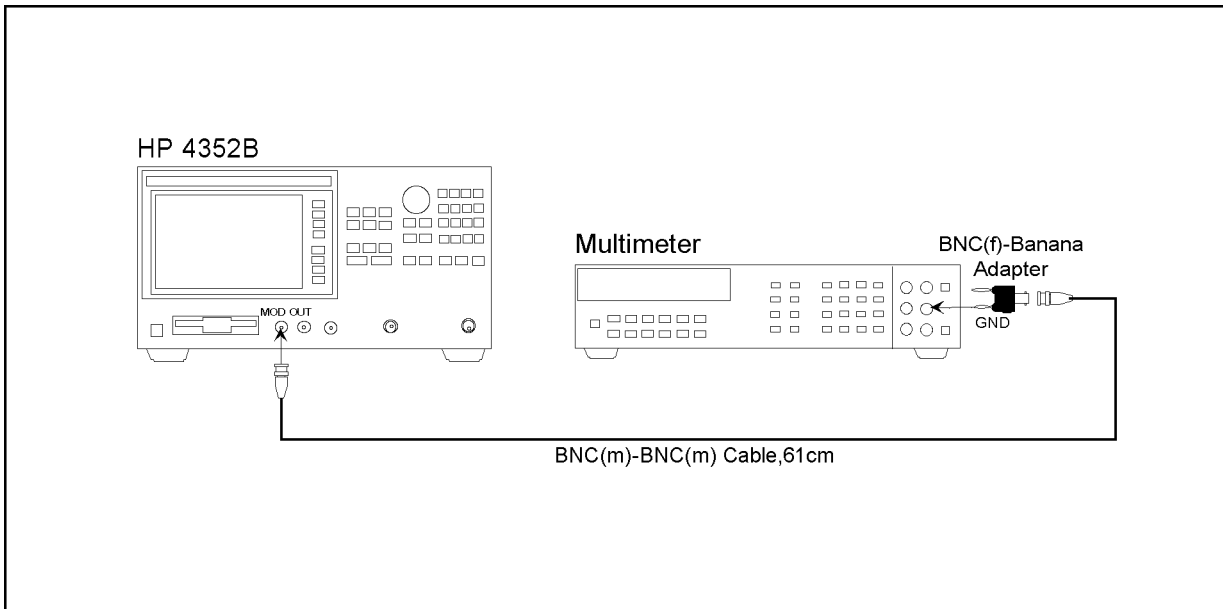

CDS02011

Figure 2-19. MOD OUT Voltage Test Setup

2. Set the multimeter to Synchronously Sub-sample AC voltage measurement mode (**ACV**, **SETACV SYNC**).
3. Press **[Preset]** to initialize the 4352B.

4. Press **(Mod)**, **MOD AMPLITUDE**, **(0)**, **(x1)** to set the MOD OUT level to 0 V_{rms}.
5. Press **MOD OUT on OFF** to output the MOD OUT level.
6. Record the multimeter reading on the Performance Test Record.
7. Press **(Mod)**, **MOD AMPLITUDE**, and the entry keys to set the MOD OUT level in accordance with the following list. Subtract each MOD OUT setting value from each multimeter reading, and record the calculated value on the Performance Test Record.
 - 0.005 V_{rms}
 - 0.25 V_{rms}
 - 0.5 V_{rms}
 - 0.75 V_{rms}
 - 1.0 V_{rms}

DC POWER CURRENT MEASUREMENT ACCURACY TEST

Description

This test verifies the accuracy of the DC POWER current measurement function. This test uses a 300 Ω resistor box to define the DC POWER current.

Specification

Current Range	0 to 50 mA
Accuracy	
@23±10°C	±(0.2% of reading + 100 μA)
@0 to 40°C	±(0.8% of reading + 400 μA)
Resolution	10μA

Test Equipment

Multimeter	3458A
BNC Cable, 61 cm, 2 ea.	PN 8120-1839
Dual Banana-BNC(f) adapter	PN 1251-2277
300 Ω Resistor Box	PN 04352-65001

Procedure

1. Connect the equipment as shown in Figure 2-20.

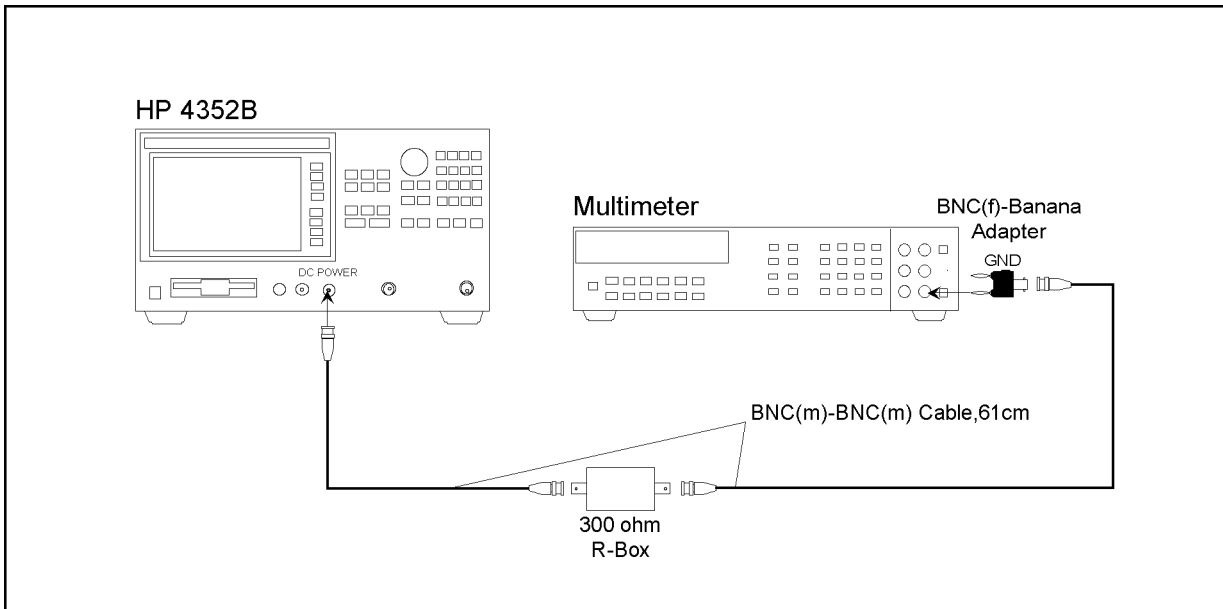

CDS02017

Figure 2-20. DC Power Current Test Setup

2. Set the multimeter to the DCI measurement mode.
3. Press **Preset** to initialize the 4352B.

4. Press **(Meas)**, **INST TYPE**, **INST TYPE: VCO TESTER** to set the instrument type to Tester Mode.
5. Press **DC POWER CURRENT** to set the measurement item to DC Power Current.
6. Press **(DC Power)**, **POWER VOLTAGE**, **(0)**, **(x1)** to set the DC POWER voltage to 0 V.
7. Press **OUTPUT on OFF** to output the DC POWER voltage.
8. Record the multimeter reading on the Performance Test Record.
9. Press **(DC Power)**, **POWER VOLTAGE**, and the entry keys to set the DC POWER voltage in accordance with the following table. Subtract each DC POWER CURRENT measurement value from each multimeter reading, and record the calculated value on the Performance Test Record.

DC POWER setting voltage	DC POWER Current through 300 Ω R-Box
0.3 V	1 mA
3 V	10 mA
6 V	20 mA
9 V	30 mA
12 V	40 mA
15 V	50 mA

PERFORMANCE TEST RECORD

Agilent Technologies 4352B VCO/PLL Signal Analyzer

Serial Number _____

Temperature _____ °C

Test Date _____

Humidity _____ %RH

Tested by _____

Frequency Measurement Test

Input Frequency	Test Limit	Test Result
10 MHz	±1 kHz	_____ kHz
100 MHz	±1 kHz	_____ kHz
1 GHz	±1 kHz	_____ kHz
3 GHz	±1 kHz	_____ kHz

Power Measurement Accuracy Test

Frequency	Input Level	Test Limit	Test Result	Measurement Uncertainty
10 MHz	0 dBm	±0.6 dB	_____ dB	±0.18 dB
50 MHz	0 dBm	±0.6 dB	_____ dB	±0.18 dB
100 MHz	0 dBm	±0.6 dB	_____ dB	±0.19 dB
500 MHz	0 dBm	±0.6 dB	_____ dB	±0.19 dB
1 GHz	0 dBm	±0.6 dB	_____ dB	±0.18 dB
1.5 GHz	0 dBm	±0.6 dB	_____ dB	±0.18 dB
2 GHz	0 dBm	±0.6 dB	_____ dB	±0.19 dB
2.5 GHz	0 dBm	±1 dB	_____ dB	±0.22 dB
3 GHz	0 dBm	±1 dB	_____ dB	±0.22 dB
50 MHz	-10 dBm	±0.6 dB	_____ dB	±0.19 dB
50 MHz	10 dBm	±0.6 dB	_____ dB	±0.18 dB
50 MHz	20 dBm	±1 dB	_____ dB	±0.22 dB

C/N Phase Noise Test

Offset Frequency	Test Limit	Test Result
1 kHz	>100 dBc	_____ dBc
10 kHz	>130 dBc	_____ dBc
100 kHz	>140 dBc	_____ dBc

C/N Measurement Accuracy Test (Flatness)

Carrier Frequency	Offset Frequency	Test Limit	Test Result	Measurement Uncertainty
10 MHz	-1 MHz	±2.0 dB	_____dB	±0.04 dB
	-1 kHz	±2.0 dB	_____dB	±0.04 dB
	+1 kHz	±2.0 dB	_____dB	±0.04 dB
	+1 MHz	±2.0 dB	_____dB	±0.04 dB
1 GHz	-10 MHz	±4.0 dB	_____dB	±0.04 dB
	-1 MHz	±2.0 dB	_____dB	±0.04 dB
	-1 kHz	±2.0 dB	_____dB	±0.04 dB
	+1 kHz	±2.0 dB	_____dB	±0.04 dB
	+1 MHz	±2.0 dB	_____dB	±0.04 dB
	+10 MHz	±4.0 dB	_____dB	±0.04 dB

C/N Measurement Accuracy Test (Linearity)

C/N	Test Limit	Test Result	Measurement Uncertainty
10 dB	±2.0 dB	_____dB	±0.08 dB
20 dB	±2.0 dB	_____dB	±0.08 dB
30 dB	±2.0 dB	_____dB	±0.08 dB
40 dB	±2.0 dB	_____dB	±0.08 dB
50 dB	±2.0 dB	_____dB	±0.08 dB
60 dB	±2.0 dB	_____dB	±0.09 dB
70 dB	±2.0 dB	_____dB	±0.15 dB
80 dB	±2.0 dB	_____dB	±0.43 dB

FM Deviation Test

Range	Min Limit	Test Result	Max Limit
200 kHz	24.4%REL	_____%	25.6%REL
20 kHz	24.475%REL	_____%	25.525%REL
2 kHz	24.375%REL	_____%	25.625%REL

Spectrum Measurement Relative Level Accuracy Test

Frequency @-10 dBm	Frequency @-70 dBm	Test Limit	Test Result	Measurement Uncertainty
1 GHz	0.999 GHz	± 1.5 dB	_____dB	±0.15 dB
1 GHz	0.998 GHz	± 1.5 dB	_____dB	±0.15 dB
1 GHz	0.997 GHz	± 1.5 dB	_____dB	±0.15 dB
1 GHz	0.996 GHz	± 1.5 dB	_____dB	±0.15 dB
1 GHz	0.995 GHz	± 1.5 dB	_____dB	±0.15 dB
1 GHz	1.001 GHz	± 1.5 dB	_____dB	±0.15 dB
1 GHz	1.002 GHz	± 1.5 dB	_____dB	±0.15 dB
1 GHz	1.003 GHz	± 1.5 dB	_____dB	±0.15 dB
1 GHz	1.004 GHz	± 1.5 dB	_____dB	±0.15 dB
1 GHz	1.005 GHz	± 1.5 dB	_____dB	±0.15 dB

Frequency Transient Frequency Accuracy Test

MIN FREQ	MAX FREQ	RF	Test Limit	Test Result	Measurement Uncertainty
320 MHz	960 MHz	880 MHz	±1.16 MHz	Max. _____MHz	330 Hz
320 MHz	960 MHz	880 MHz	±1.16 MHz	Min. _____MHz	330 Hz
854 MHz	884 MHz	880 MHz	±30 kHz	Max. _____kHz	330 Hz
854 MHz	884 MHz	880 MHz	±30 kHz	Min. _____kHz	330 Hz
878.3 MHz	880.3 MHz	880 MHz	±2 kHz	Max. _____kHz	330 Hz
878.3 MHz	880.3 MHz	880 MHz	±2 kHz	Min. _____kHz	330 Hz
10 MHz	30 MHz	25 MHz	± 30kHz	Max. _____kHz	9.4 Hz
10 MHz	30 MHz	25 MHz	± 30kHz	Min. _____kHz	9.4 Hz

DC POWER Voltage Test

DC POWER Voltage	Test Limit	Test Result	Measurement Uncertainty
0 V	±2.0 mV	_____mV	±0.001 mV
1 V	±4.0 mV	_____mV	±0.014 mV
2.5 V	±7.0 mV	_____mV	±0.033 mV
5 V	±12.0 mV	_____mV	±0.063 mV
7.5 V	±17.0 mV	_____mV	±0.093 mV
10.0 V	±22.0 mV	_____mV	±0.124 mV
12.5 V	±27.0 mV	_____mV	±0.318 mV
15 V	±32.0 mV	_____mV	±0.367 mV
15.5 V	±33.0 mV	_____mV	±0.377 mV

DC CONTROL Voltage Test

DC CONTROL Voltage	Test Limit	Test Result	Measurement Uncertainty
-15 V	±5.0 mV	_____mV	±0.367 mV (Opt.001 only)
-1 V	±19.0 mV	_____mV	±0.014 mV (Opt.001 only)
0 V	±2.0 mV	_____mV	±0.001 mV
1.2 V	±3.2 mV	_____mV	±0.017 mV
5 V	±7.0 mV	_____mV	±0.063 mV
10 V	±12.0 mV	_____mV	±0.124 mV
15 V	±17.0 mV	_____mV	±0.367 mV
20 V	±22.0 mV	_____mV	±0.466 mV
21 V	±11.0 mV	_____mV	±0.485 mV (Opt.001 only)
35 V	±25.0 mV	_____mV	±0.763 mV (Opt.001 only)

MOD OUT Voltage Test

MOD OUT Voltage	Test Limit	Test Result	Measurement Uncertainty
0 V	±1.00 mV	_____mV	±0.004 mV
0.005 V	±1.03 mV	_____mV	±0.003 mV
0.25 V	±2.25 mV	_____mV	±0.068 mV
0.5 V	±3.50 mV	_____mV	±0.112 mV
0.75 V	±4.75 mV	_____mV	±0.156 mV
1 V	±6.00 mV	_____mV	±0.200 mV

DC POWER Current Test

DC POWER Current	Test Limit	Test Result	Measurement Uncertainty
0 mA	±100 μ A	_____ μ A	±0.07 nA
1 mA	±102 μ A	_____ μ A	±0.049 μ A
10 mA	±120 μ A	_____ μ A	±0.490 μ A
20 mA	±140 μ A	_____ μ A	±2.3 μ A
30 mA	±160 μ A	_____ μ A	±3.1 μ A
40 mA	±180 μ A	_____ μ A	±3.8 μ A
50 mA	±200 μ A	_____ μ A	±4.6 μ A

Adjustments and Correction Constants

Introduction

This chapter describes the Adjustments and Correction Constants procedures required to ensure that the 4352B VCO/PLL Signal Analyzer is within its specifications. These adjustments should be performed along with periodic maintenance to keep the analyzer in optimum operating condition. The recommended calibration period is 24 months. If proper performance cannot be achieved after the Adjustments and Correction Constants procedures are performed, see Chapter 4.

Note

The correction constants are empirically derived data that are stored in memory and then recalled to refine the analyzer's measurement and to define its operation.

Safety Considerations

This manual contains NOTES, CAUTIONS, and WARNINGS that must be followed to ensure the safety of the operator and to keep the instrument in a safe and serviceable condition. The adjustments must be performed by qualified service personnel.

Warning

Any interruption of the protective ground conductor (inside or outside the analyzer) or disconnection of the protective ground terminal can make the instrument dangerous. Intentional interruption of the protective ground system for any reason is prohibited.

The removal or opening of covers for adjustment, or removal of parts other than those that are accessible by hand will expose circuits containing dangerous voltage levels.

Remember that the capacitors in the analyzer can remain charged for several minutes, even through you have turned the analyzer OFF and unplugged it.

Warning

The adjustments described in this chapter are performed with power applied and the protective covers removed. Dangerous voltage levels exist at many points and can result in serious personal injury or death if you come into contact with them.

Required Equipment

Table 1-1 lists the equipment required to perform the Adjustments and the Correction Constants procedures described in this chapter. Use only calibrated test equipment when adjusting the analyzer. If the recommended test equipment is not available, equipment whose specifications are equal to, or surpasses those of the recommended test equipment may be used.

Adjustment Program

The adjustment program must be used to adjust the 4352B and to update the correction constants of the 4352B. The adjustment program is provided on one disk. The disk's Agilent part number is 04352-18010 . The file contained on the diskette is ADJ4352B.EXE, self-extracting file.

Note



To prevent accidental deletion or destruction of the program, make working copies of the furnished master diskette. Use the working copies for daily use. Keep the master diskette in a safe place and use it only for making working copies.

The following equipment is required when using the adjustment program.

- HP E2120C HP VEE for Windows
- 82335B / 82340A GPIB Card
- Personal Computer: HP Vectra series
 - Microprocessor
 - 80486, 66 MHz or faster
 - RAM
 - Minimum: 16 MB (megabytes)
 - Recommended: 20 MB
 - Mass Storage A 3.5-inch (1.44 MHB) floppy disk drive, and a hard disk drive with at least 15 MB of free disk space.
 - Display system
 - Ultra VGA (1024-by-768)
 - Operating System
 - MS-DOS Version 5.0 or later
 - Microsoft Windows NT

Warm-up for Adjustments and Correction Constants

Warm-up the analyzer for at least 30 minute before performing any of the following Adjustments and Correction Constants procedures to ensure proper results and correct instrument operation.

Instrument Cover Removal

To gain access to the adjustment components, be careful when removing the top cover and the side covers.

Order Of Adjustments and Correction Constants

When performing more than one Adjustments or Correction Constants procedure, perform them in the order they appear in this chapter. The procedures are presented in the following order:

- Reference Frequency Adjustment
- Third Mixer Feedthrough Adjustment
- Third IF Amp Gain Adjustment
- EEPROM Write-ID and Initial Correction Constants
- Crystal Filter Frequency Response Correction Constants
- FV Converter Correction Constants
- DC Power Voltage Correction Constants
- DC Control Voltage Correction Constants
- MOD OUT Level Correction Constants
- DC Power Current Correction Constants
- RF Power Linearity Correction Constants
- RF Power Flatness Correction Constants
- Spectrum Measurement Correction Constants

Preparation for Using the Adjustment Program

Correction Constants are updated using the following procedure:

1. Connect the equipment as shown in Figure 3-1

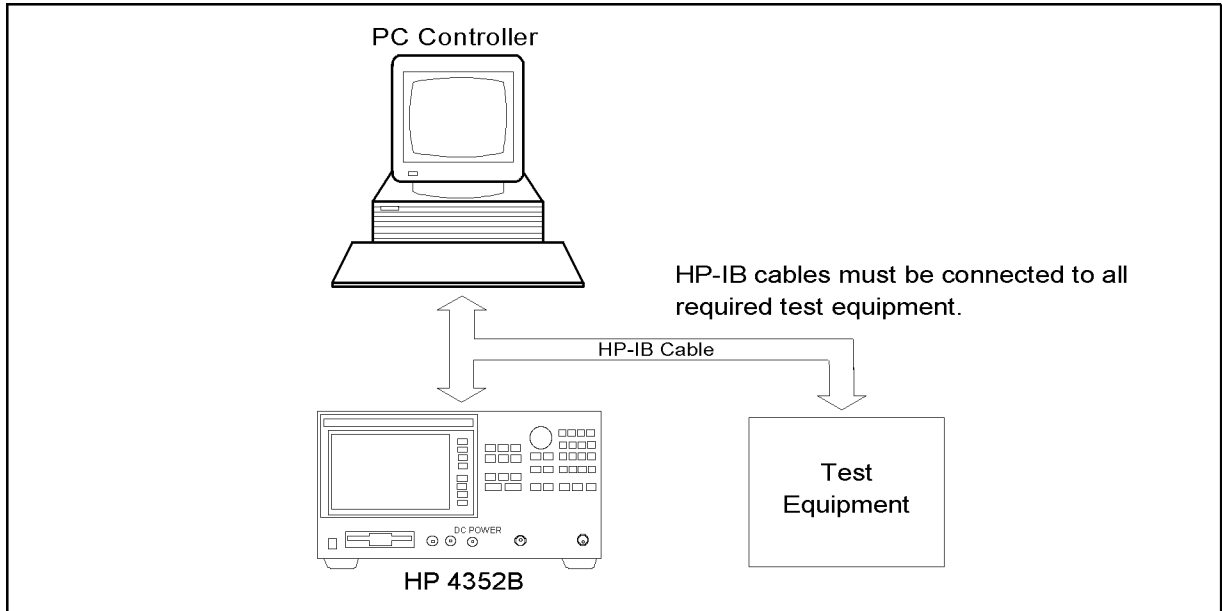

Figure 3-1. Updating Correction Constants Setup

Note

Press **(Local)**, **ADDRESSABLE ONLY** to set the 4352B to the addressable only mode.



2. Run Microsoft Windows.
3. Make the directory `c:\vee4352b` in your c: drive using the File Manager.
4. Put the adjustment program disk in the a: drive (3.5 inch FDD).
5. Copy `a:adj4352b.exe` to `c:\vee4352b\adj4352b.exe`.
6. From the Windows Program Manager, pull down the File menu and click on Run. The RUN dialog box will be displayed.
7. Type the following: `c:\vee4352b\adj4352b.exe` in the command line text box. Click on *OK*. All files and directories will be automatically extracted.
8. Run HP VEE software by double-clicking its icon.
9. Click on *File* and select *OPEN*. Type "`c:\vee4352b\4352b.vee`". Then click on *OK*. The 4352B adjustment program will load. Wait until the 4352B adjustment program basic menu as shown in Figure 3-2 is displayed.

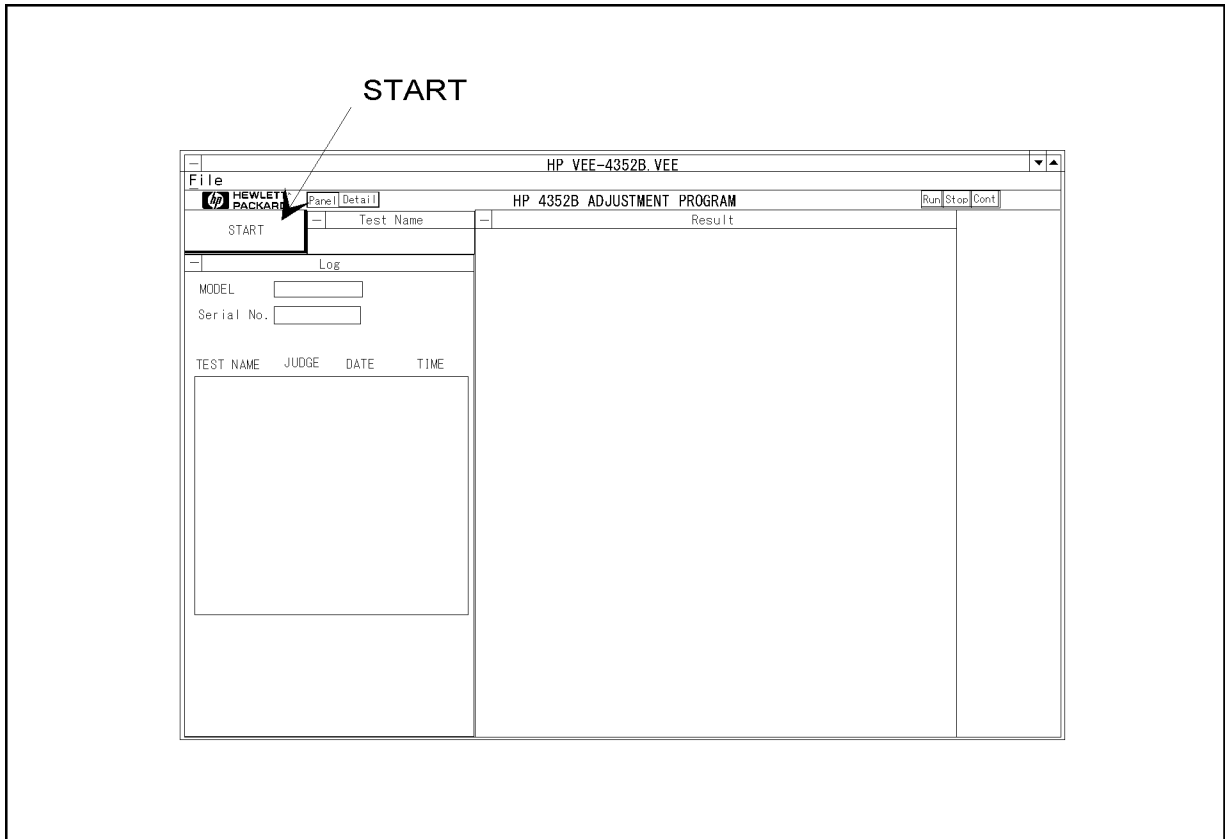

CDS03VE1

Figure 3-2. 4352B Adjustment Program Basic Menu

10. Click on *START*. GPIB Address menu will be displayed. Choose the model number of your test equipment. Set the GPIB address and time for time out for each item. Then Click on *OK*.
11. The Setup Menu will be displayed as shown in Figure 3-3. Click on *OK*. If you want to save to a different drive or directory, change the drive letter and path (default is c:\vee4352b), and click on *OK*.

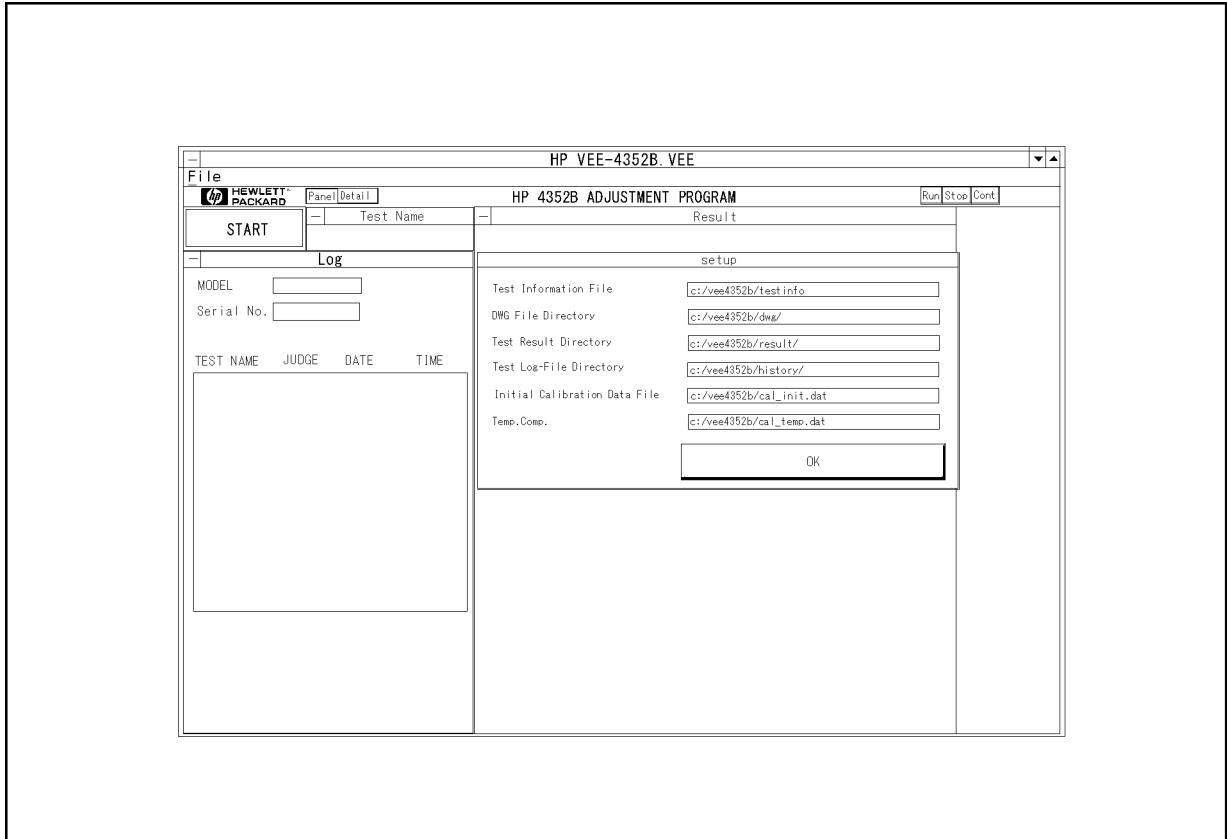

CDS03VE2

Figure 3-3. Setup Menu

12. The Calibration Factor Entry Menu for an 8482A will be displayed. Edit the reference calibration factor and the calibration factor to match your power sensor. Then click on *OK*.
13. The Serial Number Entry Menu will be displayed. Enter the serial number, and click on *If OK, Push here!* .
14. The list Box Menu will be displayed as shown in Figure 3-4. Choose the adjustment items using the mouse. Click on *OK* to start the adjustment procedures. If you click on *Select All*, you can easily activate all adjustment items. These selected adjustments are performed in the listed order.

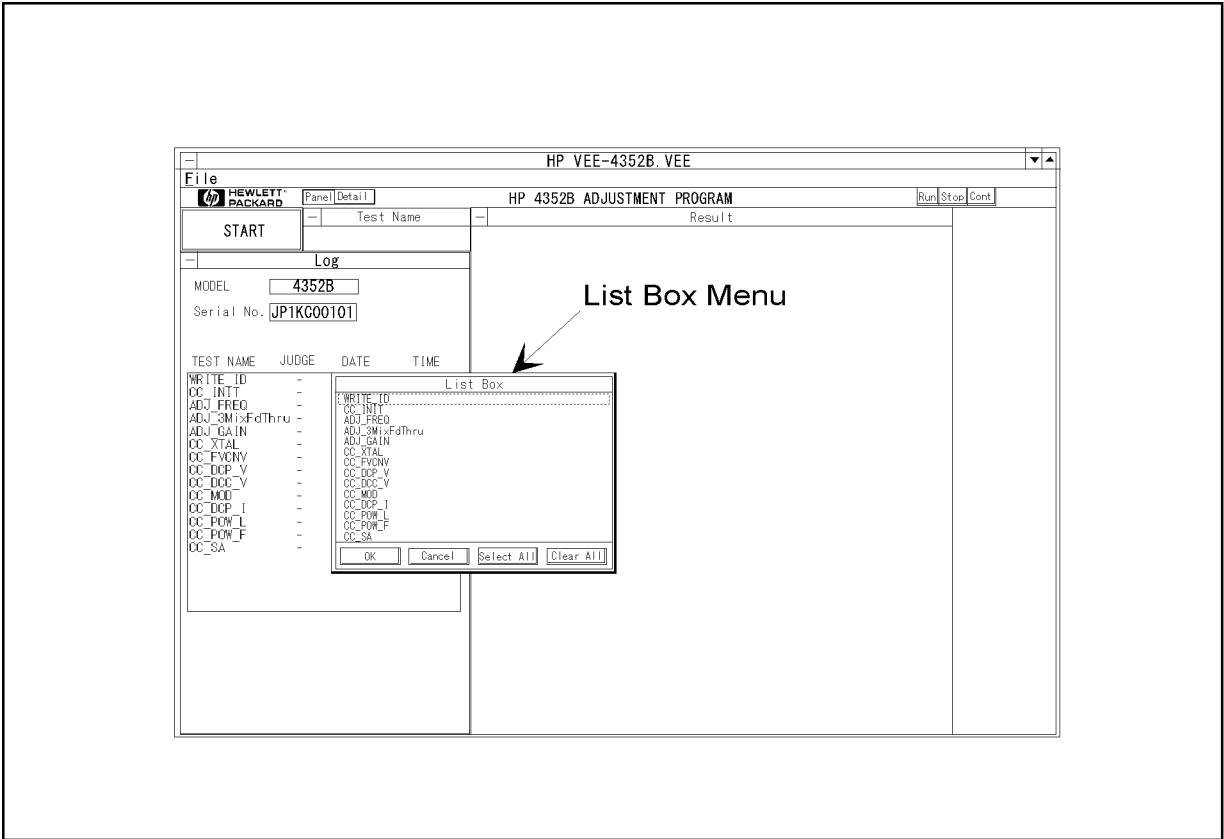

CDS03VE3

Figure 3-4. List Box Menu

REFERENCE FREQUENCY ADJUSTMENT

The purpose of this procedure is to adjust the 40 MHz reference oscillator frequency.

Required Equipment

Frequency Counter	5334B
BNC cable, 122 cm	PN 8120-1840

Procedure

1. Run the HP VEE adjustment program and display the list box menu.
2. Click on *ADJ_FREQ* to choose the Reference Frequency Adjustment in the list box menu. Then click on *OK*.
3. Follow the adjustment program instructions to adjust the reference frequency. Figure 3-5 shows the equipment setup for this adjustment, and Figure 3-6 shows the adjustment location.

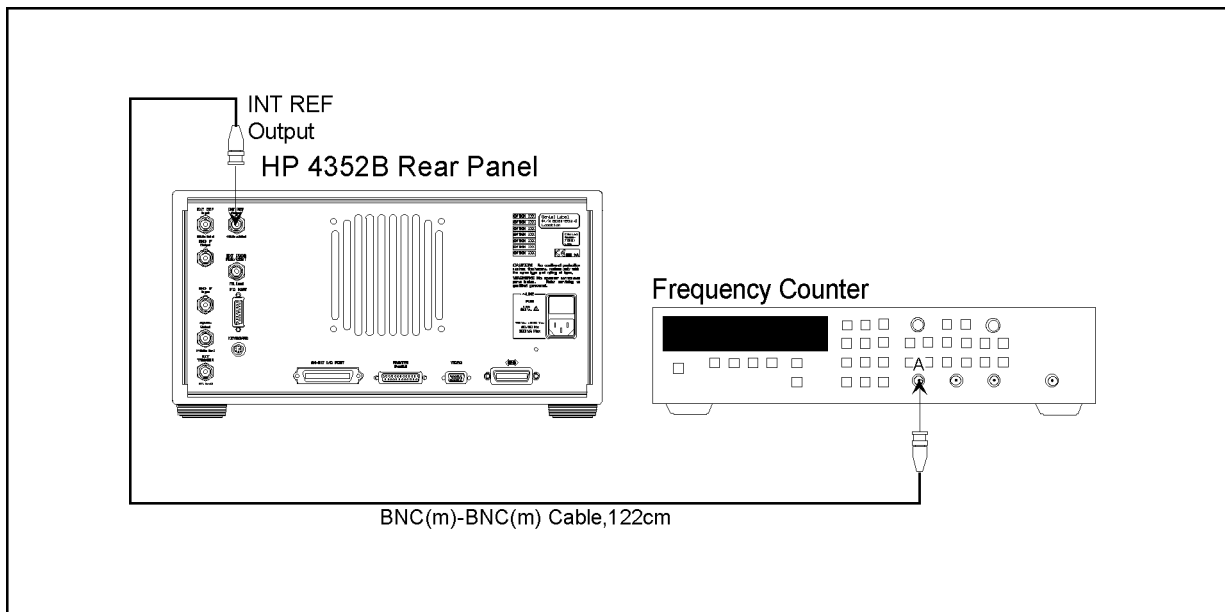

CDS03001

Figure 3-5. Reference Frequency Adjustment Setup

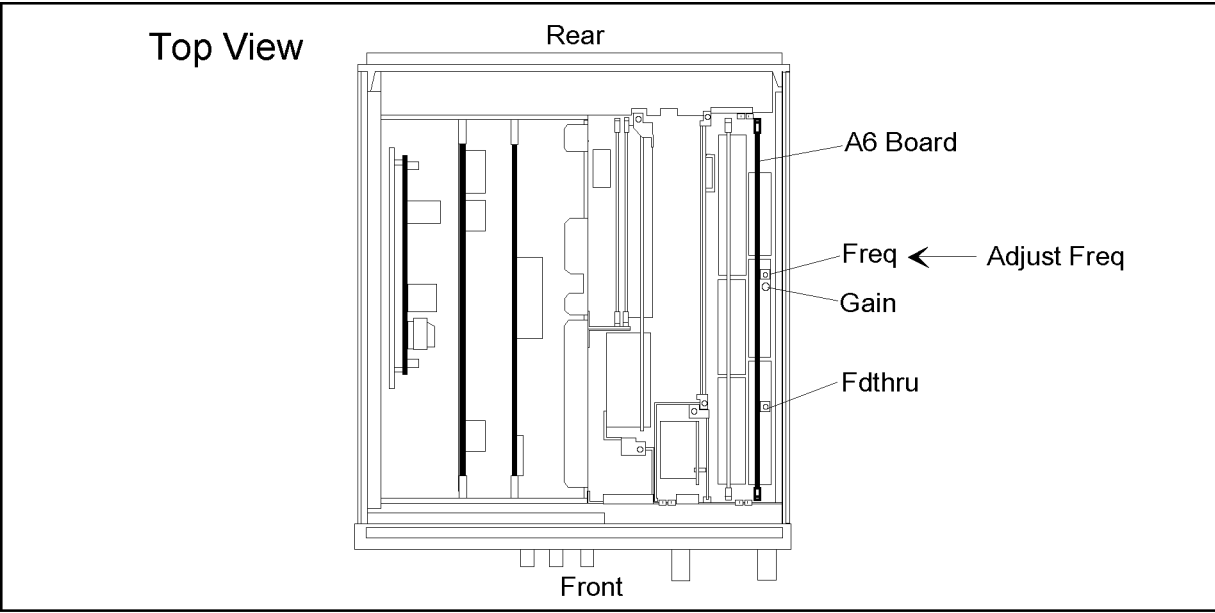

CDS03002

Figure 3-6. Reference Frequency Adjustment Location

THIRD MIXER FEEDTHROUGH ADJUSTMENT

The purpose of this procedure is to minimize the leakage of the 3rd mixer.

Required Equipment

None

Procedure

1. Run the HP VEE adjustment program and display the list box menu.
2. Click on *ADJ_3MixFdThru* to choose the Third Mixer Feedthrough Adjustment in the list box menu. Then click on *OK*.
3. Follow the adjustment program instructions to adjust the third mixer feedthrough. Figure 3-7 shows the adjustment location.

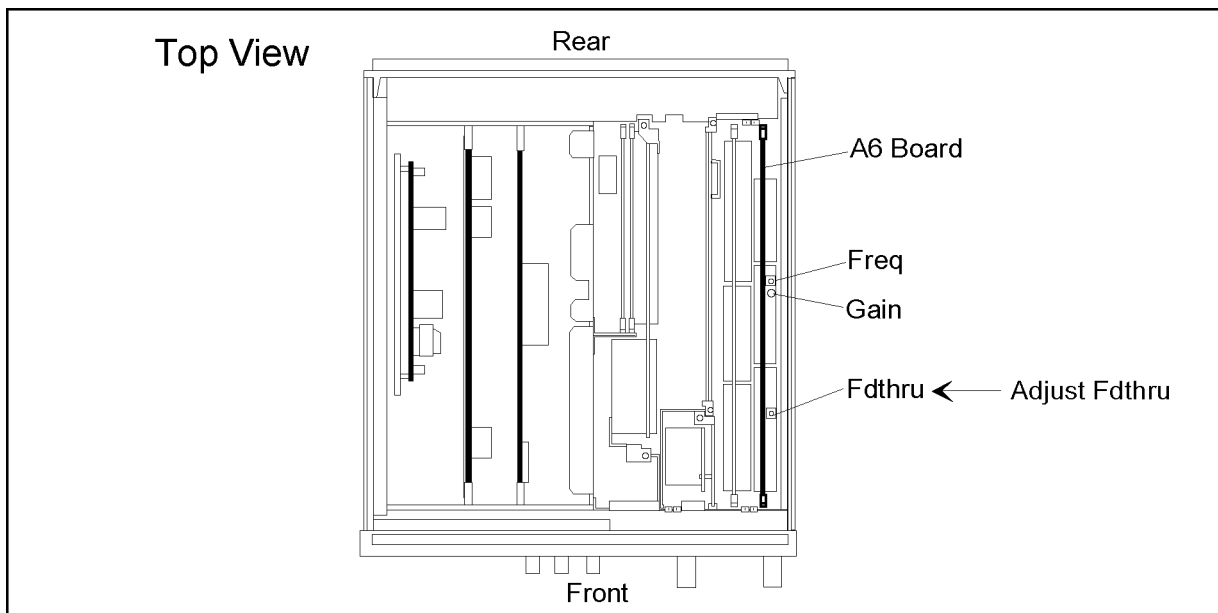

CDS03003

Figure 3-7. Third Mixer Feedthrough Adjustment Location

THIRD IF AMP GAIN ADJUSTMENT

The purpose of this procedure is to maximize the dynamic range of the 3rd IF Amplifier gain.

Required Equipment

Function Generator	3325B
BNC cable, 122 cm, 2 ea.	PN 8120-1840

Procedure

1. Run the HP VEE adjustment program and display the list box menu.
2. Click on *ADJ_GAIN* to choose the Third IF Amp Gain Adjustment in the list box menu. Then click on *OK*.
3. Follow the adjustment program instructions to adjust the reference frequency. Figure 3-8 shows the equipment setup for this adjustment, and Figure 3-9 shows the adjustment location.
4. After this adjustment, connect the BNC-BNC adapter between the 2nd IF Input and Output connectors on the 4352B rear panel.

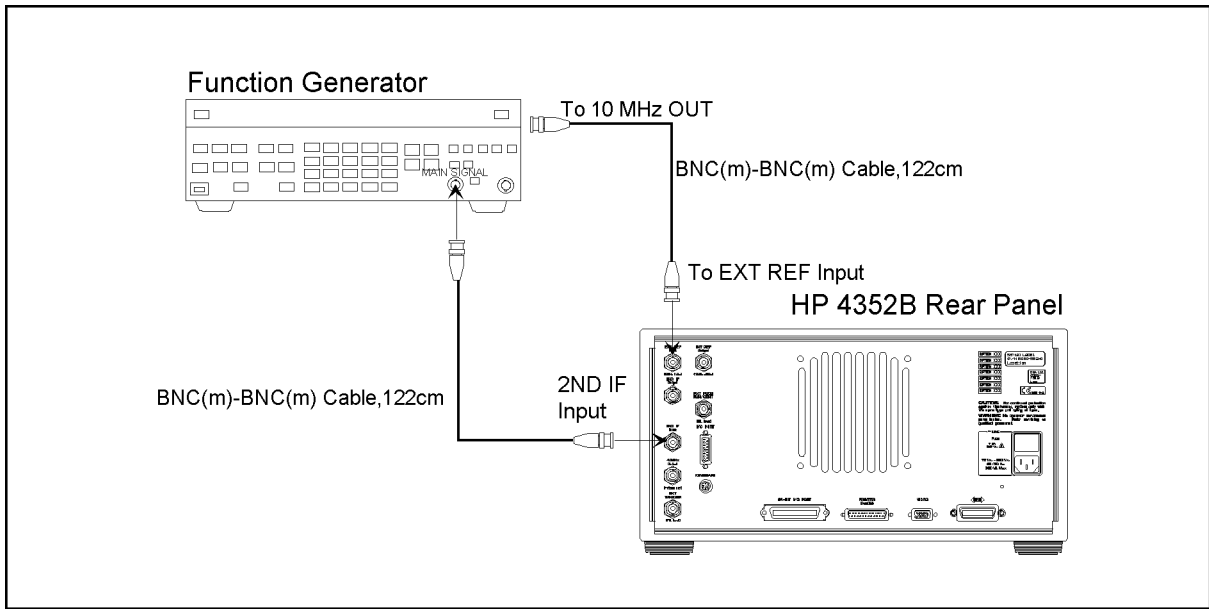

CDS03004

Figure 3-8. Third IF AMP GAIN Adjustment Setup

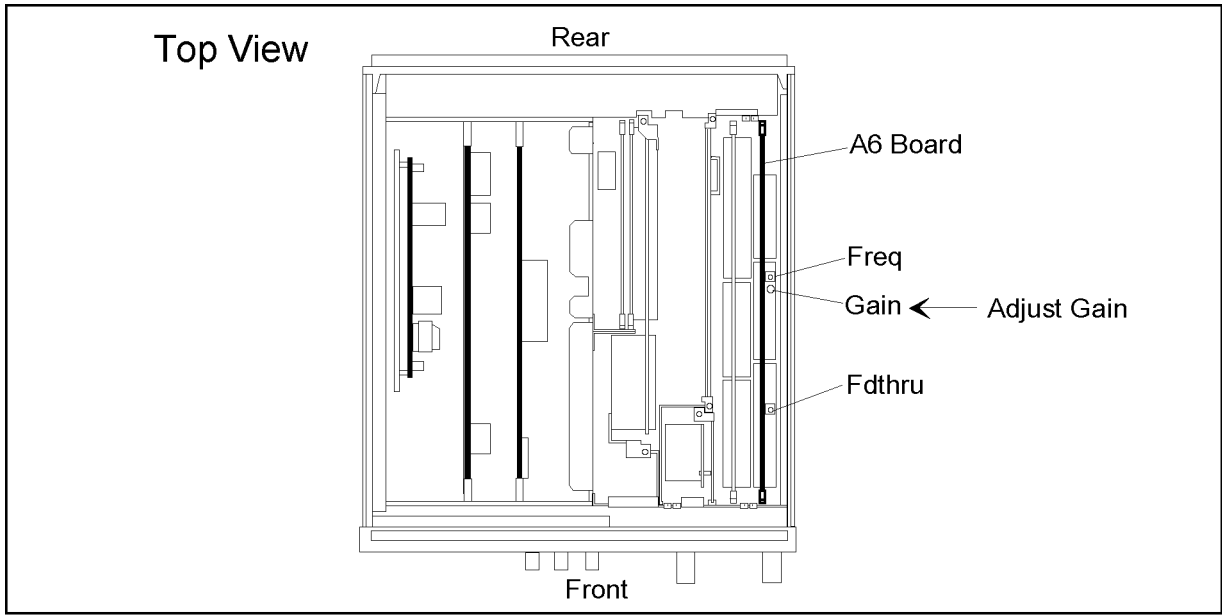

CDS03005

Figure 3-9. Third IF AMP GAIN Adjustment Location

EEPROM WRITE-ID AND INITIAL CORRECTION CONSTANTS

The purpose of this procedure is to write the ID and initial correction constants data into EEPROM when replacing a defective A1 CPU or EEPROM with new one.

Required Equipment

None

Procedure

1. Run the HP VEE adjustment program and display the list box menu.
2. Click on *WRITE_ID* and *CC_INIT* to choose the WRITE-ID and Initial Correction Constants in the list box menu. Then click on *OK*.
3. Follow the adjustment program instructions to write the data into EEPROM.

CRYSTAL FILTER FREQUENCY RESPONSE CORRECTION CONSTANTS

The purpose of this procedure is to obtain the correction constants that correct the crystal filter frequency response.

Required Equipment

Function Generator	3325A
BNC cable, 122 cm, 2 ea.	PN 8120-1840

Procedure

1. Run the HP VEE adjustment program and display the list box menu.
2. Click on *CC_XTAL* to choose the Crystal Filter Frequency Response Correction Constants in the list box menu. Then click on *OK*.
3. Follow the adjustment program instructions to update the correction constants. Figure 3-10 shows the equipment setup for these correction constants.
4. After this adjustment, connect the BNC-BNC adapter between the 2nd IF Input and Output connectors on the 4352B rear panel.

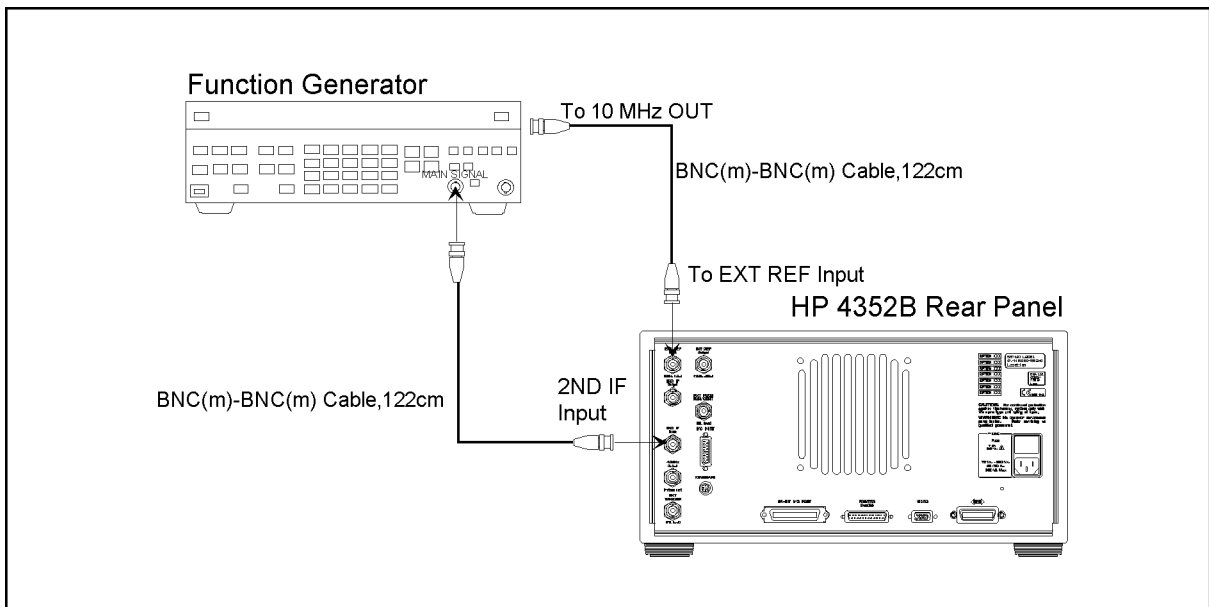

CDS03004

Figure 3-10. Crystal Filter Frequency Response Correction Constants Setup

FV CONVERTER CORRECTION CONSTANTS

The purpose of this procedure is to obtain the correction constants that correct the F-V Converter for FM Deviation and RF Transient measurements.

Required Equipment

Signal Generator (LO SG#1)	8664A/8665B/8753D
Signal Generator (RF SG#2)	8664A/8665B
N(m)-N(m) cable, 61 cm, 2 ea.	11500B or part of 11851B
BNC cable; 61 cm, 2 ea.	PN 8120-1839

Procedure

1. Run the HP VEE adjustment program and display the list box menu.
2. Click on *CC_FVCNV* to choose the Crystal FV Converter Correction Constants in the list box menu. Then click on *OK*.
3. Follow the adjustment program instructions to update the correction constants. Figure 3-11 shows the equipment setup for these correction constants.

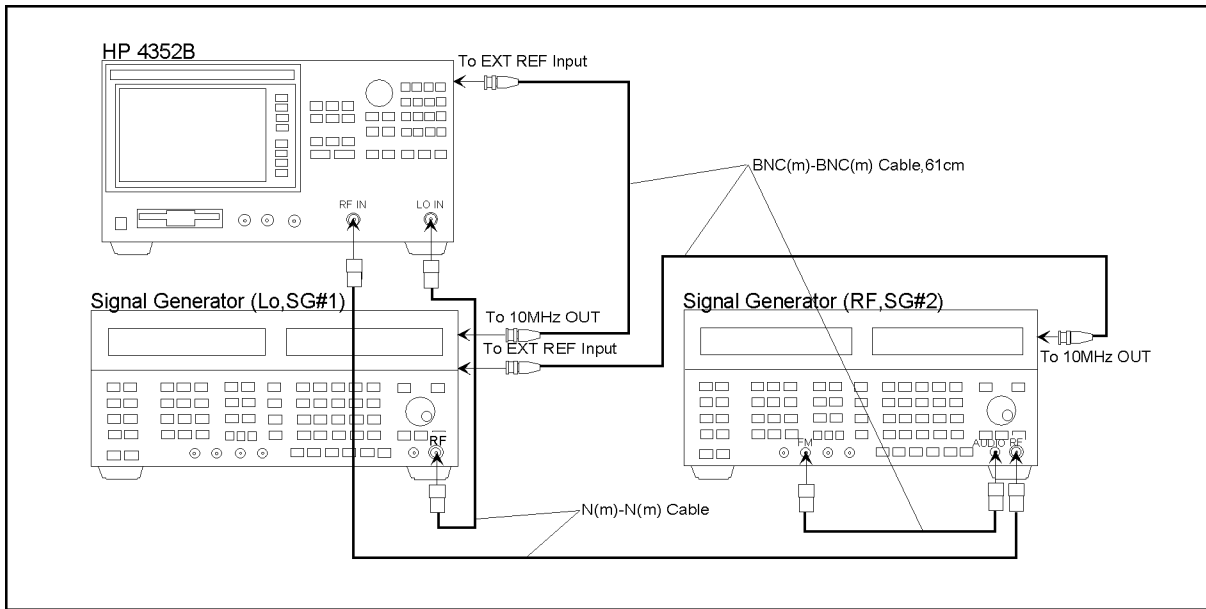

CDS03016

Figure 3-11. F-V Converter Correction Constants Setup

DC POWER VOLTAGE CORRECTION CONSTANTS

The purpose of this procedure is to obtain the correction constants that correct the DC POWER output voltage.

Test Equipment

Multimeter	3458A
BNC cable, 61 cm	PN 8120-1839
BNC(f)-Dual Banana adapter	PN 1251-2277

Procedure

1. Run the HP VEE adjustment program and display the list box menu.
2. Click on *CC_DCP_V* to choose the DC Power Voltage Correction Constants in the list box menu. Then click on *OK*.
3. Follow the adjustment program instructions to update the correction constants. Figure 3-12 shows the equipment setup for these correction constants.

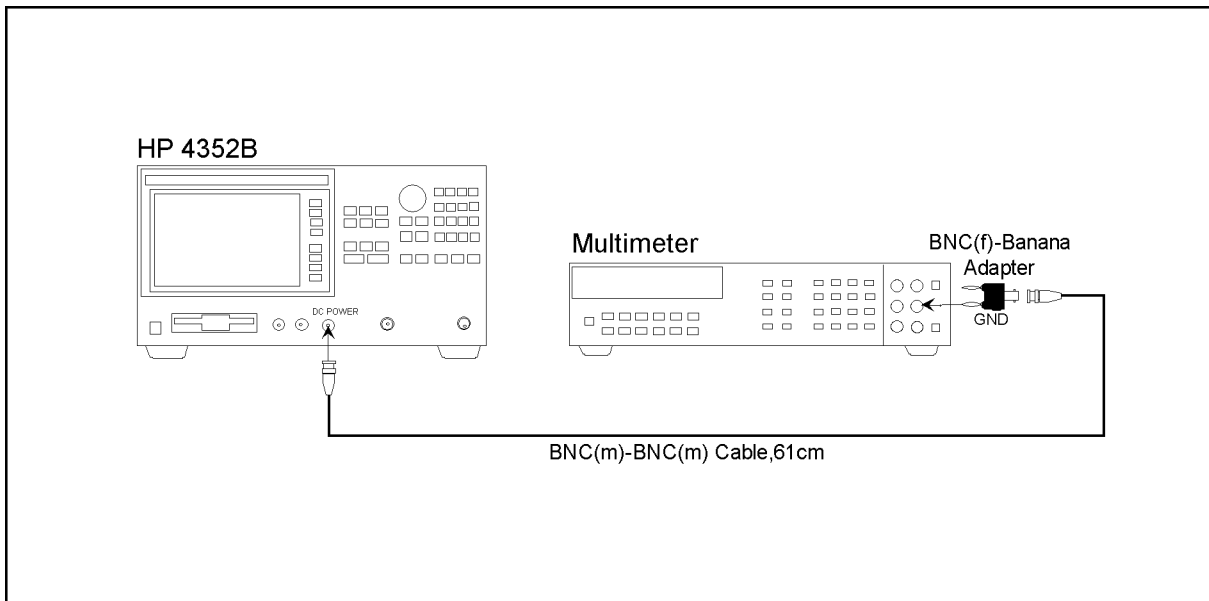

CDS02009

Figure 3-12. DC Power Voltage Correction Constants Setup

DC CONTROL VOLTAGE CORRECTION CONSTANTS

The purpose of this procedure is to obtain the correction constants that correct the DC CONTROL output voltage.

Required Equipment

Multimeter	3458A
BNC Cable, 61 cm	PN 8120-1839
Dual Banana-BNC(f) adapter	PN 1251-2277

Procedure

1. Run the HP VEE adjustment program and display the list box menu.
2. Click on *CC_DCC_V* to choose the DC Control Voltage Correction Constants in the list box menu. Then click on *OK*.
3. Follow the adjustment program instructions to update the correction constants. Figure 3-13 shows the equipment setup for these correction constants.

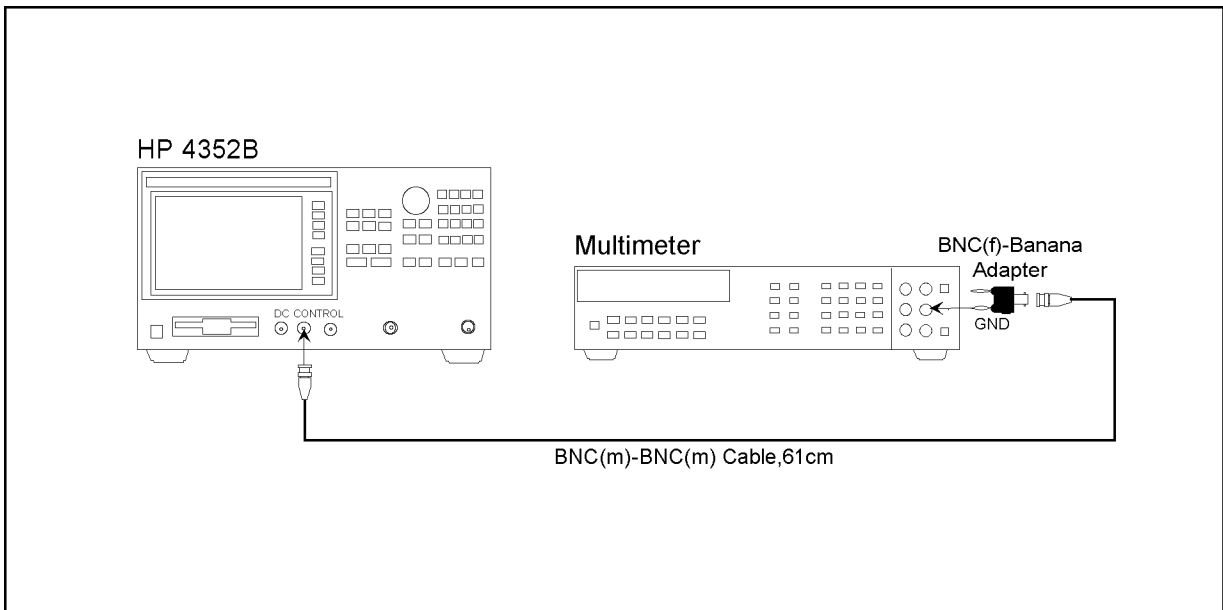

CDS02010

Figure 3-13. DC Control Voltage Correction Constants Setup

MOD OUT LEVEL CORRECTION CONSTANTS

The purpose of this procedure is to obtain the correction constants that correct the MD OUT voltage.

Required Equipment

Multimeter	3458A
BNC Cable, 61 cm	PN 8120-1839
Dual Banana-BNC(f) adapter	PN 1251-2277

Procedure

1. Run the HP VEE adjustment program and display the list box menu.
2. Click on *CC_MOD* to choose the MOD OUT level Correction Constants in the list box menu. Then click on *OK*.
3. Follow the adjustment program instructions to update the correction constants. Figure 3-14 shows the equipment setup for these correction constants.

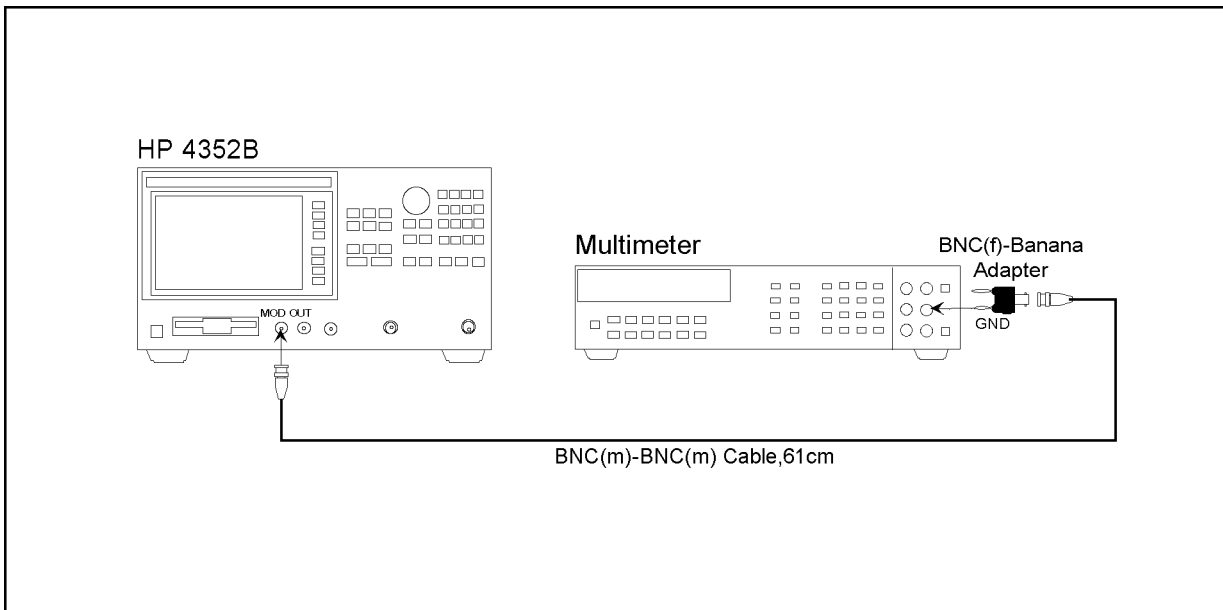

CDS02011

Figure 3-14. MOD OUT Level Correction Constants Setup

DC POWER CURRENT CORRECTION CONSTANTS

The purpose of this procedure is to obtain the correction constants that correct the DC POWER current measurement.

Test Equipment

Multimeter	3458A
BNC Cable, 61 cm	PN 8120-1839
300 ohm R-Box	PN 04352-65001
Dual Banana-BNC(f) adapter	PN 1251-2277

Procedure

1. Run the HP VEE adjustment program and display the list box menu.
2. Click on *CC_DCP_I* to choose the DC Power Current Correction Constants in the list box menu. Then click on *OK*.
3. Follow the adjustment program instructions to update the correction constants. Figure 3-15 shows the equipment setup for these correction constants.

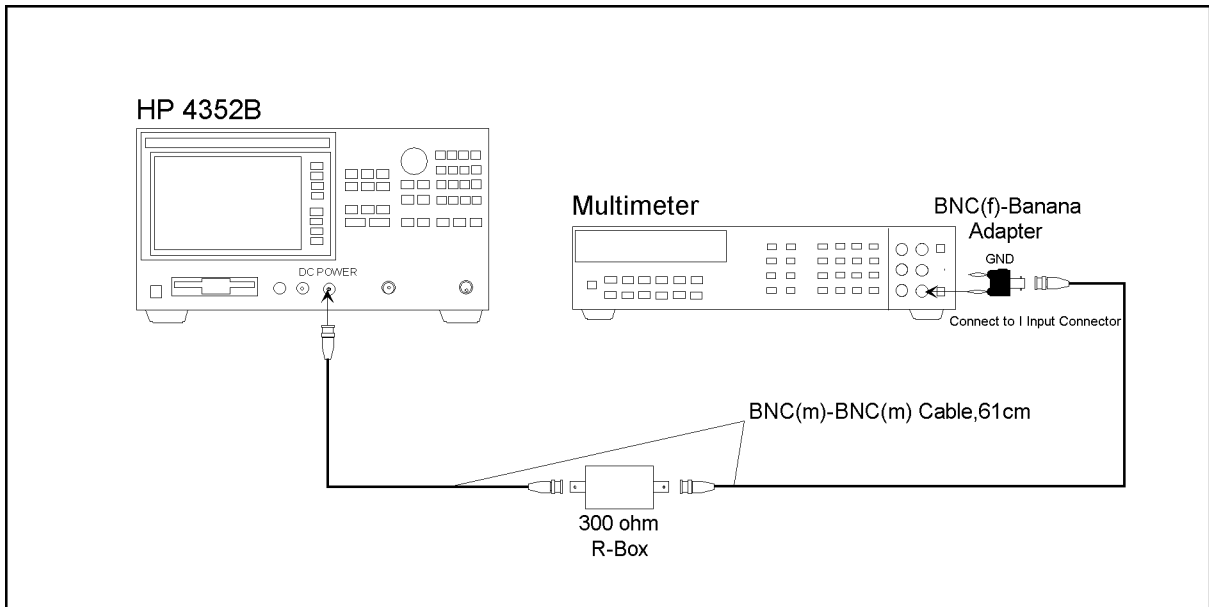

CDS03017

Figure 3-15. DC Power Current Correction Constants Setup

RF POWER LINEARITY CORRECTION CONSTANTS

The purpose of this procedure is to obtain the correction constants that correct the linearity of RF POWER measurement.

Required Equipment

Signal Generator (LO SG#1)	8664A/8665B/8753D
Signal Generator (RF SG#2)	8664A/8665B
Power Meter	436A
Power Sensor	8482A
Power Amplifier (35 dB)	A & K A3000-2H-R
Power Splitter	11667A
N(m)-N(m) adapter, 50 Ω	PN 1250-1475
N(m)-SMA(m) adapter, 2 ea.	PN 1250-1636
N(m)-N(m) Cable, 61 cm, 2 ea.	11500B or part of 11851B
BNC Cable, 122 cm	PN 8120-1840

Procedure

1. Run the HP VEE adjustment program and display the list box menu.

Note Before performing this procedure, calibrate the power meter with the power sensor.



2. Click on *CC_POW_L* to choose the RF Power Linearity Correction Constants in the list box menu. Then Click on *OK*.
3. Follow the adjustment program instructions to update the correction constants. Figure 3-16 and Figure 3-17 show the equipment setup for these correction constants.

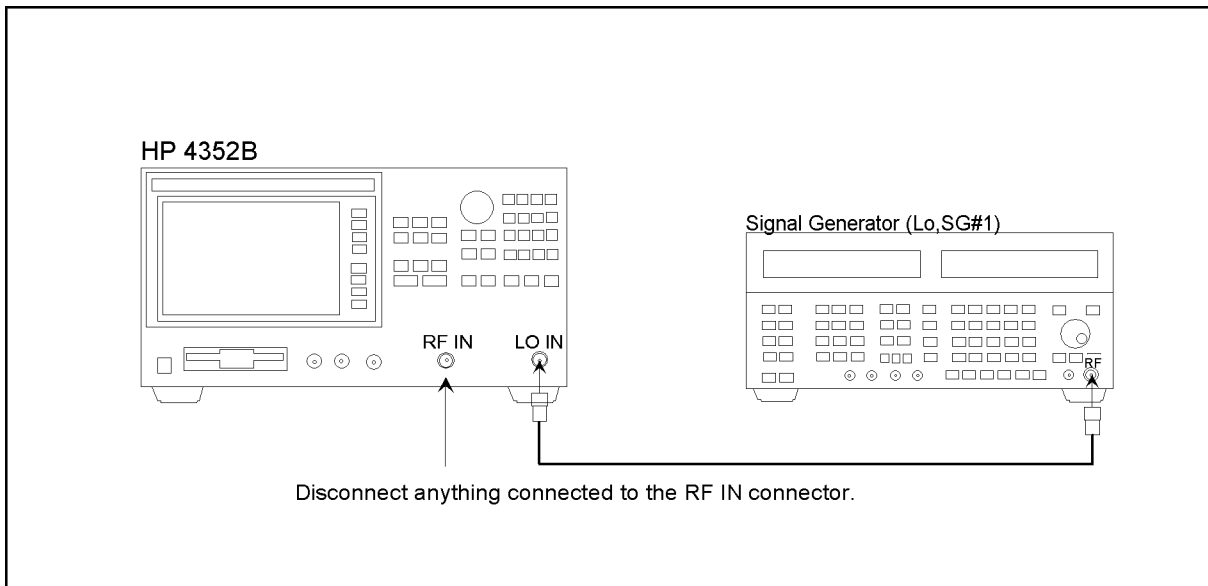

CDS03018

Figure 3-16. RF Power Linearity Correction Constants Setup 1

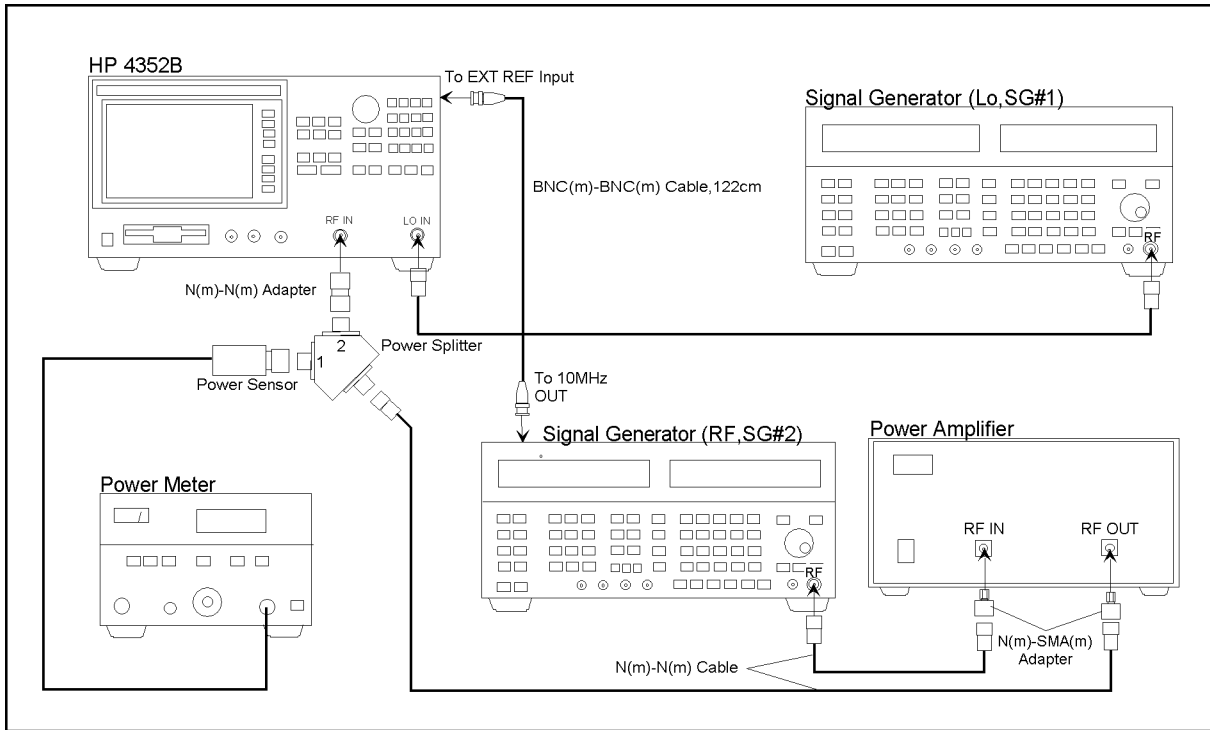

CDS03019

Figure 3-17. RF Power Linearity Correction Constants Setup 2

Caution



To prevent any damage to the 4352B from large input levels, turn the power amplifier off immediately performing this procedure.

RF POWER FLATNESS CORRECTION CONSTANTS

The purpose of this procedure is to obtain the correction constants that correct the flatness of RF POWER measurement.

Required Equipment

Signal Generator (LO SG#1)	8664A/8665B/8753D
Signal Generator (RF SG#2)	8664A/8665B
Power Meter	436A
Power Sensor	8482A
Power Splitter	11667A
N(m)-N(m) adapter, 50Ω	PN 1250-1475
N(m)-N(m) cable, 61 cm	11500B or part of 11851B
BNC cable, 122 cm, 2 ea.	PN 8120-1840

Procedure

1. Run the HP VEE adjustment program and display the list box menu.

Note

Before performing this procedure, calibrate the power meter with the power sensor.



2. Click on *CC_POW_F* to choose the RF Power Flatness Correction Constants in the list box menu. Then click on *OK*.
3. Follow the adjustment program instructions to update the correction constants. Figure 3-18 shows the equipment setup for these correction constants.

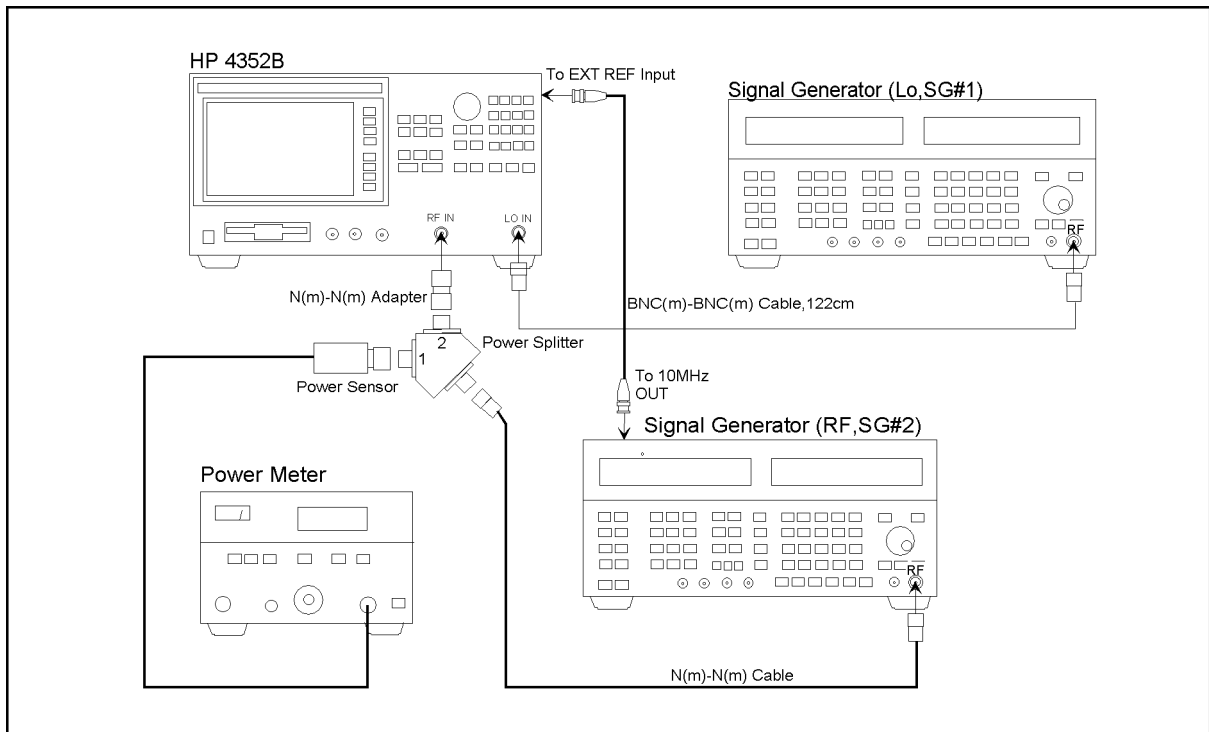

Figure 3-18. RF Power Flatness Correction Constants Setup

SPECTRUM MEASUREMENT CORRECTION CONSTANTS

The purpose of this procedure is to obtain the correction constants that correct the absolute level of the spectrum measurement.

Required Equipment

Signal Generator (RF,SG#1)	8664A/8665B/8753D
Signal Generator (Lo,SG#2)	8664A/8665B
Power Meter, 2 ea.	436A
Power Sensor, 2 ea.	8482A
Power Splitter	11667A
10 dB Fixed Attenuator	8491A Opt.010, H60
N(m)-N(m) adapter, 50Ω	PN 1250-1475
N(m)-N(m) cable, 61 cm, 2 ea.	11500B or part of 11851B
BNC cable, 122 cm, 2 ea.	PN 8120-1840
GPIB Cable	PN 8120-3445

Procedure

1. Run the HP VEE adjustment program and display the list box menu.

Note

Before performing this procedure, calibrate the power meter with the power sensor.



2. Click on *CC_SA* to choose the Spectrum Measurement Correction Constants in the list box menu. Then click on *OK*.
3. Follow the adjustment program instructions to update the correction constants. Figure 3-19 shows the equipment setup for these correction constants.

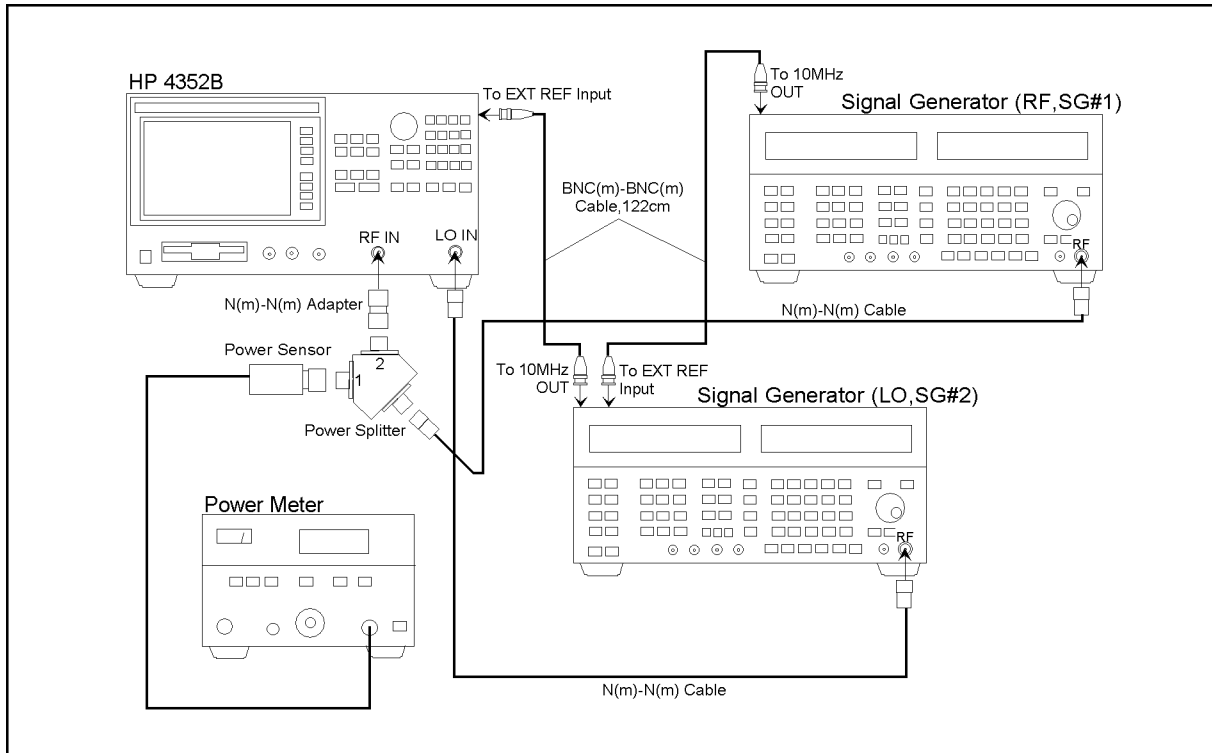

CDS03020

Figure 3-19. Spectrum Measurement Correction Constants Setup

4. After updating these correction constants, perform the following procedures to verify the the absolute amplitude accuracy of the spectrum measurement.

Note The following verification is performed without the adjustment program.



5. Connect the power sensor #A to the power meter #A. Calibrate the power meter #A for the power sensor #A. Set the power meter #A's display unit of the power meter to dBm. Connect the power sensor #B to the power meter #B. Calibrate the power meter #B for the power sensor #B. Set the power meter #B's display unit of the power meter to dBm.
6. Obtain the tracking error data of the power splitter in according with the following procedure.
 - a. Connect the test equipment as shown in Figure 3-20.

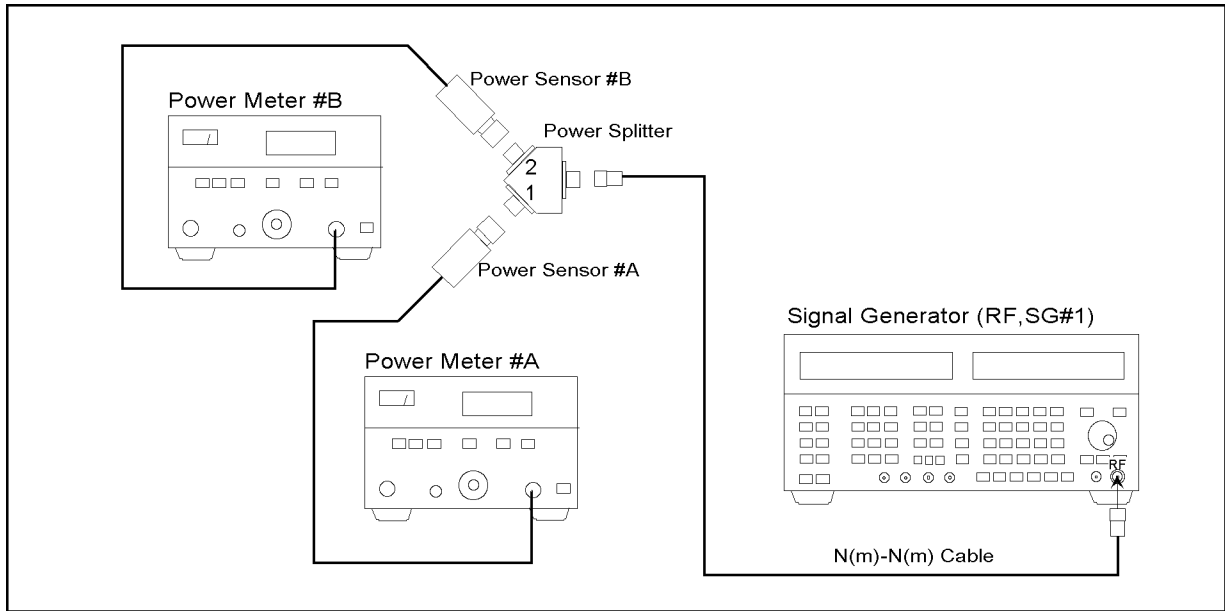

CDS02002

Figure 3-20. Power Splitter Tracking Error Measurement Setup 1

- b. Set the signal generator output level to 6 dBm.
- c. Set the output frequency of the signal generator in accordance with the following table, and record each power meter value at each frequency as PMA1(XXX) and PMB1(XXX) (where, XXX is the SG's setting frequency).

SG Frequency	Power Meter #A Value as:	Power Meter #B Value as:
10 MHz	PMA1(10M)	PMB1(10M)
80 MHz	PMA1(80M)	PMB1(80M)
800 MHz	PMA1(800M)	PMB1(800M)
3 GHz	PMA1(3G)	PMB1(3G)

- d. Reverse the power splitter connection as shown in Figure 3-21.

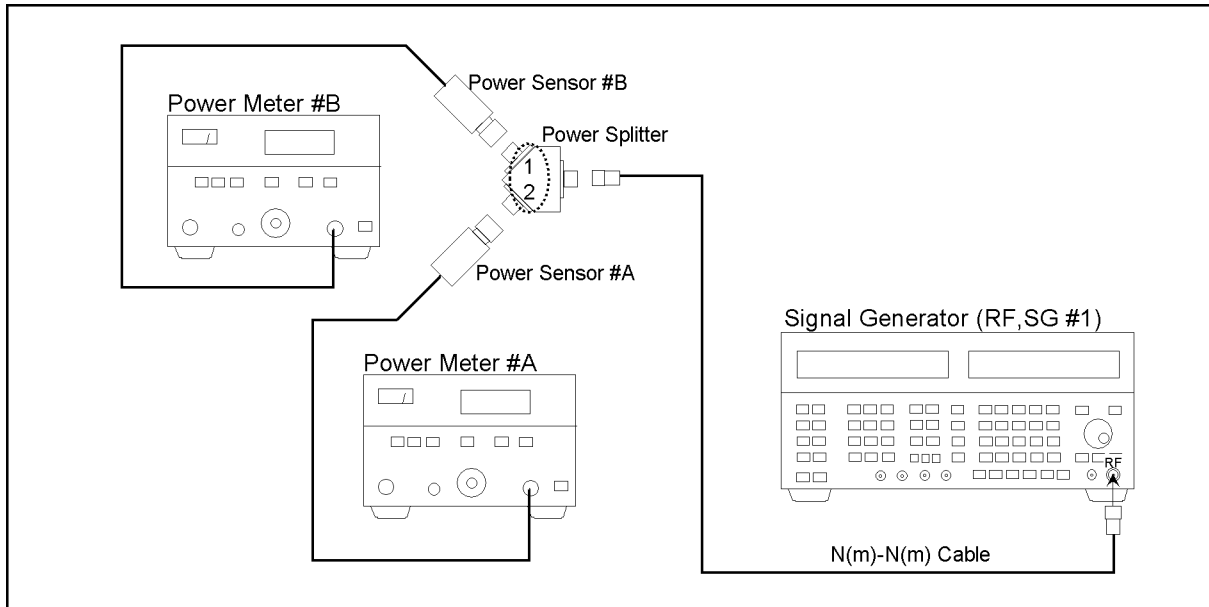

CDS03021

Figure 3-21. Power Splitter Tracking Error Measurement Setup 2

- e. Repeat the step c except for the name recorded. Use PMA2(XXX), PMB2(XXX) instead of PMA1(XXX), PMB1(XXX), respectively.
 - f. Calculate the following formula. Note each calculated value as Track(XXX).

$$\text{Tack(XXX)} = \{ \text{PMA1(XXX)} - \text{PMB1(XXX)} \} - \{ \text{PMA2(XXX)} - \text{PMB2(XXX)} \} / 2$$
7. Connect the test equipment as shown in Figure 3-22.

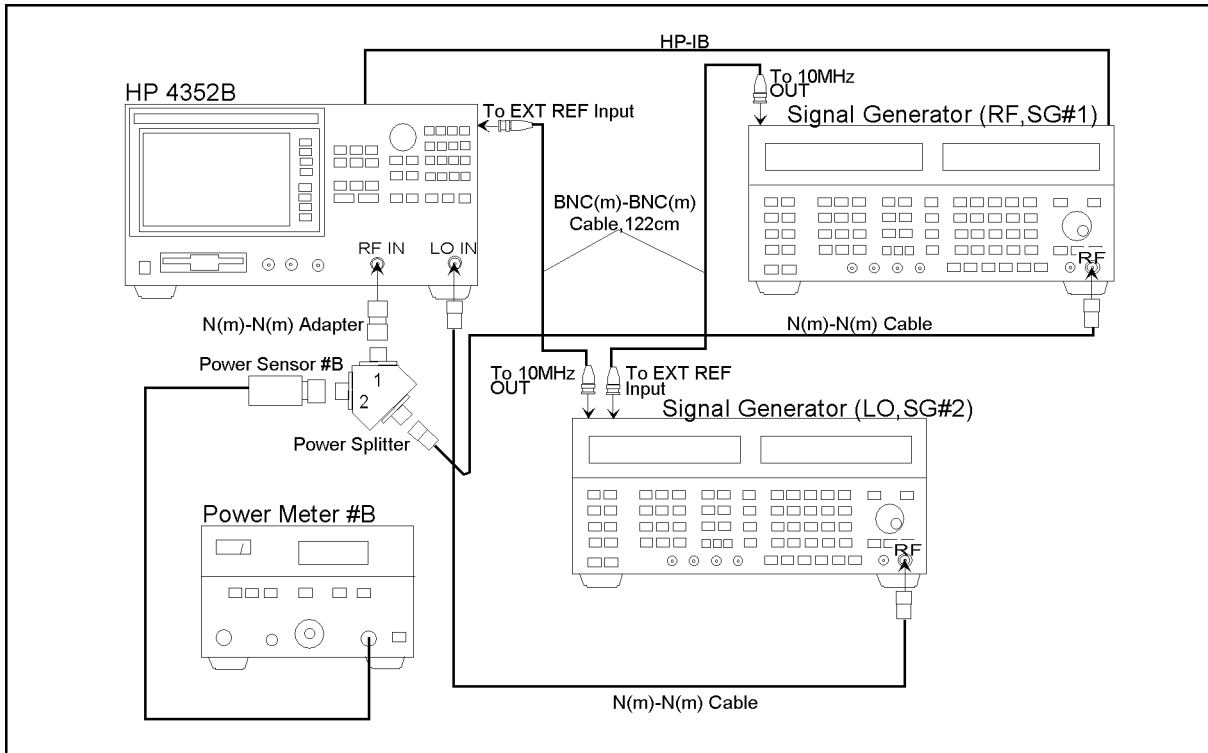

CDS03022

Figure 3-22. Absolute Amplitude Measurement Accuracy Test Setup

Note



Connect the signal generator's 10 MHz frequency reference output to the 4352B EXT REF Input on the rear panel as shown in Figure 3-22. With this configuration, both the signal generators and the 4352B are phased locked to the same reference frequency to obtain a stable measurement.

Note



In this test, the 4352B uses the signal generator (LO,SG#2) as the first local oscillator. The 4352B automatically controls SG#2 via GPIB by performing the following procedures.

- a. Connect the GPIB cable between the 4352B and the signal generator.
- b. Press **[Local]**, **SYSTEM CONTROLLER**. Then press **SET ADDRESSES**, **ADDRESS: SG** and the entry keys to set the GPIB address of the signal generator (LO,SG#2). (The factory default setting of the signal generator address is 19.)
- c. Press **[RF/LO]**, **SG TYPE**, **[1]**, **[x1]** to set the signal generator type to the 8664A.
- d. Press **[Preset]** to initialize the 4352B. Confirm that the SG#2's GPIB remote indicator is lit.

8. Press **[Preset]** to initialize the 4352B.

9. Press **[Meas]**, **INST TYPE**, **VCO ANALY** to set the instrument type to Analyzer mode.

10. Set the 4352B controls as follows:

Control Settings	Keystrokes
Meas.mode: Spectrum	(Meas), SPECTRUM
RF ATTEN = 0 dB	(Sense Range), RF ATTEN, (0), (x1)
SPAN = 10 kHz	(Menu), SWEEP, SPAN, (1), (0), (k/m)
RBW = 1 kHz	(Bw/Avg), RES BW, (1), (k/m)
AVERAGING: ON (AVG = 16)	(Bw/Avg), AVERAGING on OFF

11. Set the signal generator (Lo,SG#2) output level to 1 dBm.

12. Set the signal generator (Lo,SG#2) output frequency to 10 MHz.

13. Press (Menu), SWEEP, CENTER, (1), (0), (.), (0), (0), (5), (M/μ) to set the center frequency to 10.005 MHz.

14. Press (Menu), MARKER, (Menu), MKR SEARCH, MAX, and note the 4352B amplitude reading at 10 MHz input signal.

15. Subtract the 4352B reading and the power splitter tracking error with the power meter reading as in following formula:

$$\text{Test Result} = 4352\text{B reading} - \text{Power Meter reading} + \text{Track(XXX)}$$

Confirm that the test result is within the range of ± 2 dB.

16. Set the signal generator and the 4352B center frequency in accordance with the following list. Repeat step 9 through step 11. Confirm that each test result is within the range of ± 2 dB.

- 80 MHz
- 800 MHz
- 2.999995 GHz

Overall Troubleshooting

INTRODUCTION

This chapter describes overall troubleshooting summary and provides a procedure to determine whether the analyzer is faulty, or not. The procedure is performed first in the troubleshooting section of this manual.

TROUBLESHOOTING SUMMARY

The troubleshooting strategy of this manual is based on a verification (rather than symptomatic) approach. This chapter's first step is to verify the operation of the analyzer alone, independent of the signal generator or system peripherals. Peripherals are devices like computers, disk drives, and plotters, for instance, which typically use an GPIB connection and a line connection. This chapter also suggests remedies for system problems external to the analyzer.

This chapter identifies one or more faulty groups in the analyzer's four functional groups. Then refers the technician to the appropriate chapter. The four functional groups are power supply, digital control, source, and receiver. Descriptions of these groups are provided in the *Theory of Operation* chapter.

Figure 4-1 diagrams the troubleshooting organization.

Post-Repair Procedures is the last chapter of this manual. *Post-Repair Procedures* is organized by assembly and notes what adjustment to perform and how to verify proper instrument operation following the replacement of an assembly.

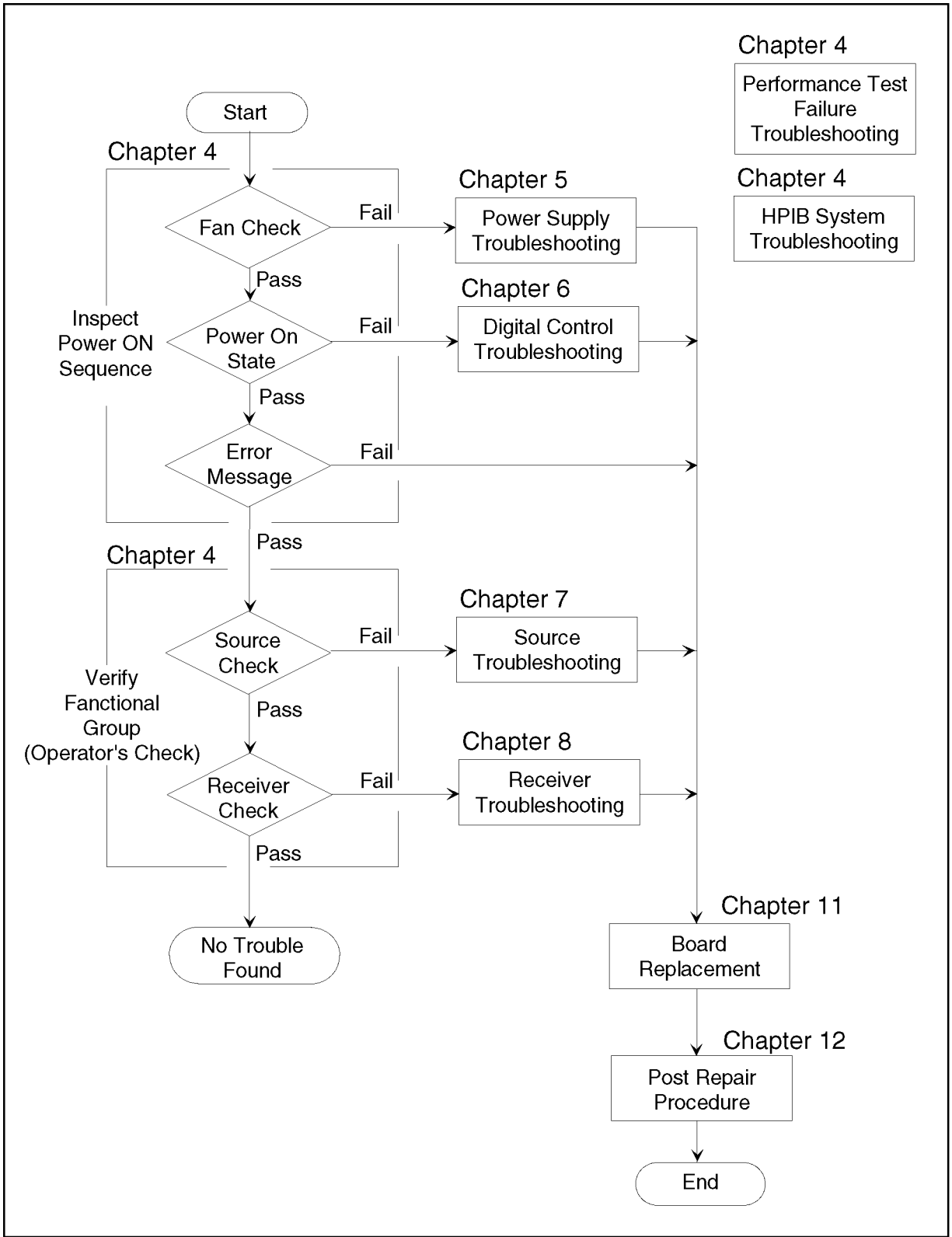

CAS04001

Figure 4-1. Troubleshooting Organization

START HERE

A system failure can be caused by a problem in the analyzer and its accessories or external to the analyzer (in a peripheral or in programming). To verify the operation of the analyzer alone, perform the following procedure.

1. Disconnect everything from the analyzer: GPIB cable, and RF cables, etc.
2. Perform the *INSPECT THE POWER ON SEQUENCE* in this chapter.
3. Perform the *OPERATOR's CHECK* in this chapter.
4. Perform the *PERFORMANCE TEST FAILURE TROUBLESHOOTING* in this chapter.
5. Perform the *TROUBLESHOOTING GPIB SYSTEM* in this chapter.

INSPECT THE POWER ON SEQUENCE

Check the Fan

Turn the analyzer power on. Inspect the fan on the rear panel.

- The fan should be rotating and audible.

If case of unexpected results, check AC line power to the analyzer. Check the fuse (rating listed on the rear panel). Check the line voltage setting. For setting the line voltage, see the *Power Requirements* in Appendix B.

If the problem persists, continue with the *Power Supply Troubleshooting* chapter.

Check the Front Panel LED

Turn on the analyzer and watch for the following events in this order:

1. Beep is sounding.
2. The beep stops.
3. Within a minute, LCD should come up bright.
4. “Internal test in progress” is shown for several seconds.

If case of unexpected results, continue with *Digital Control Troubleshooting* chapter.

Check Error Message

Turn the analyzer power on. Inspect the LCD. No error message should be displayed.

If one of the error message or status annotation listed below appears on the LCD, follow the instructions described below.

- If one of the following error messages is displayed, troubleshoot the power supply group in Chapter 5.
 - POWER FAILED ON ---
 - POWER FAILED ON PostRegHot
- If one of the following error messages or the status annotation (SVC) is displayed, troubleshoot the digital control group in Chapter 6.
 - EEPROM CHECK SUM ERROR
 - DUAL PORT SRAM R/W ERROR
 - CPU DRAM R/W ERROR

Note POWER ON TEST FAILED indicates the power on self-test failed.



These error messages indicate that one of power-on self tests failed. If an other error message appears, refer to the appendix *Error Messages* .

OPERATOR'S CHECK

The *Operator's Check* verifies that the analyzer is functioning properly. This is an excellent test to begin troubleshooting measurement problems.

When you want to test the individual analyzer specifications, perform the performance tests in accordance with the Chapter 2 in this manual.

Test Equipment

Digital Multimeter	3458A
Dual Banana-BNC(m) Cable	PN 1251-2277
BNC(m)-BNC(m) Cable, 61 cm	PN 8120-1839
BNC(m)-BNC(m) Cable, 122 cm, 2 ea.....	PN 8120-1840
BNC(f)-N(m) Adapter, 2 ea.	PN 1250-1477

Procedure to check the source group

1. Connect the equipment as shown in Figure 4-2.

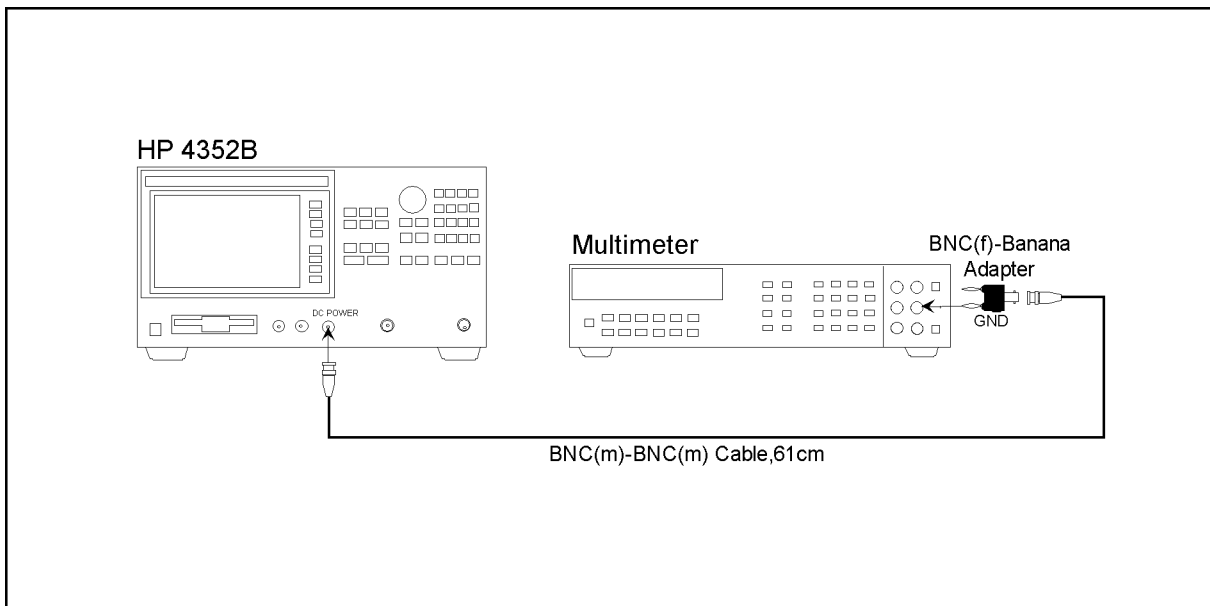

CDS02009

Figure 4-2. Source Group Check Setup

2. Turn the analyzer power on.
3. Set the multimeter to the DCV measurement mode.
4. Press **[Preset]** to initialize the analyzer.
5. Press **[DC Power]**, **POWER VOLTAGE**, **[1]**, **[5]**, **[.]**, **[5]**, **[x1]** to set the DC POWER voltage to 15.5 V. Press **OUTPUT** on **OFF** to activate the dc output.
6. Confirm that the multimeter reading value is 15.5 V \pm 33 mV. If it fails, go to the *Source Group Troubleshooting* Chapter.
7. Press **OUTPUT ON off** to turn the dc output off.

8. Remove the BNC cable from the DC POWER connector, and connect the BNC cable to the DC CONTROL connector.
9. Press **DC Control**, **CTRL VOLTAGE**, **2**, **0**, **x1** to set the DC CONTROL voltage to 20 V. Press **OUTPUT on OFF** to activate the dc output.
10. Confirm that the multimeter reading value is $20\text{ V} \pm 22\text{ mV}$. If it fails, go to the *Source Group Troubleshooting* Chapter.
11. If the unit is equipped with the Option 001, perform the step 12 through 17. If the unit is not, skip the steps.
12. Press **DC Control**, **MIN CTRL VOLTAGE**, **-**, **1**, **5**, **x1** to set the minimum DC CONTROL voltage to -15 V .
13. Press **MAX CTRL VOLTAGE**, **3**, **5**, **x1** to set the maximum DC CONTROL voltage to 35 V .
14. Press **CTRL VOLTAGE**, **-**, **1**, **5**, **x1** to set the DC CONTROL voltage to -15 V . Press **OUTPUT on OFF** to activate the dc output.
15. Confirm that the multimeter reading value is $-15\text{ V} \pm 5\text{ mV}$. If it fails, go to the *Source Group Troubleshooting* Chapter.
16. Press **CTRL VOLTAGE**, **3**, **5**, **x1** to set the DC CONTROL voltage to 35 V . Press **OUTPUT on OFF** to activate the dc output.
17. Confirm that the multimeter reading value is $35\text{ V} \pm 25\text{ mV}$. If it fails, go to the *Source Group Troubleshooting* Chapter.
18. Press **OUTPUT ON off** to turn the dc output off.
19. Remove the BNC cable from the DC CONTROL connector, and connect the BNC cable to the MOD OUT connector.
20. Set the multimeter to the Synchronously Sub-sample AC voltage measurement mode (**ACV**, **SETACV SYNC**).
21. Press **Mod**, **MOD AMPLITUDE**, **1**, **x1** to set the modulation amplitude to 1 Vrms. Press **MOD OUT on OFF** to activate the modulation output.
22. Confirm that the multimeter reading value is $1\text{ V} \pm 6\text{ mV}$ @1 kHz. If it fails, go to the *Source Group Troubleshooting* Chapter.

Procedures to check the receiver group

Perform the following steps to check the receiver group. If one or more test fail, note the test results, and go to the *Receiver Group Troubleshooting* chapter.

1. Connect the equipment as shown in Figure 4-3.

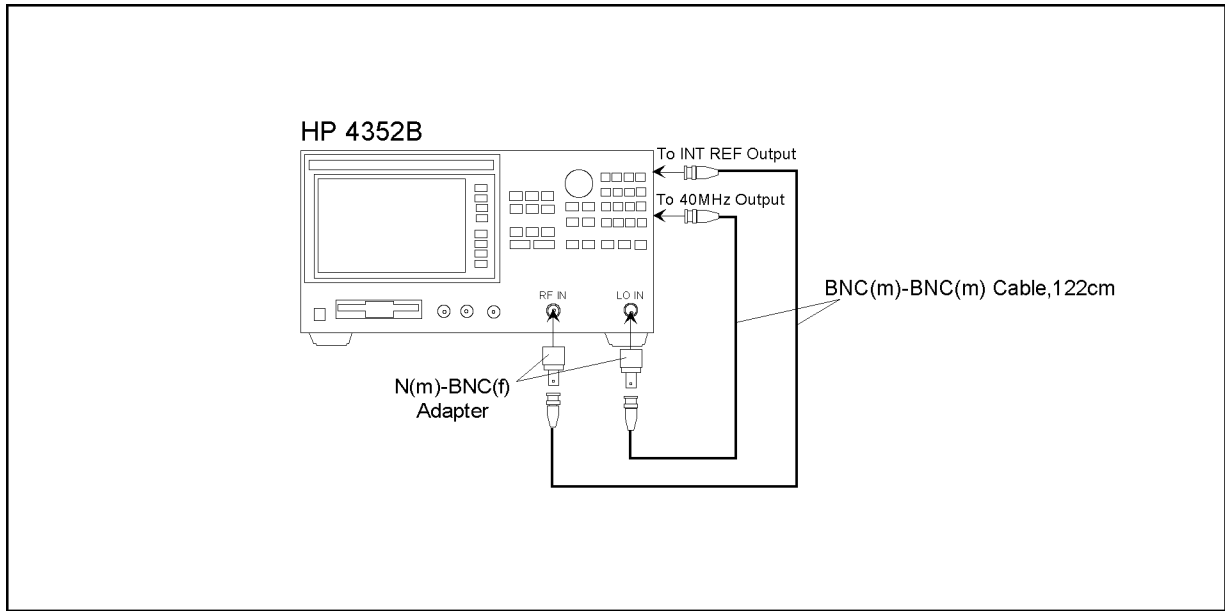

CDS02004

Figure 4-3. Receiver Group Check Setup

2. Check RF POWER measurement.
 - a. Press **(Preset)**, **(Meas)**, **INST TYPE**, **INST TYPE: VCO TESTER**, **MEAS: RF POWER**.
 - b. Confirm the reading value is within $2.5 \text{ dBm} \pm 1 \text{ dB}$. Record the result (pass or fail) as **RESULT(RF)**.
3. Check FREQUENCY measurement.
 - a. Press **(Meas)**, **FREQUENCY**, **(Sense Range)**, **FREQ RES: 64 kHz**.
 - b. Confirm the reading value is within $10 \text{ MHz} \pm 100 \text{ kHz}$. Record the result (pass or fail) as **RESULT(FREQ)**.
4. Check FM Deviation measurement.
 - a. Press **(Meas)**, **FM DEVIATION**, **(Sense Range)**, **FM DEV RANGE**, **FM DEV RNG: 2kHz**, **(Bw/Avg)**, **FM DETECTION**, **HP FILTER: 300 Hz**, **LP FILTER: 3 kHz**.
 - b. Confirm the reading value is equal to, or less than $3 \text{ Hz}_{\text{rms}}$. Record the result (pass or fail) as **RESULT(FM)**.
5. Check Carrier/Noise ratio measurement.
 - a. Press **(Meas)**, **CARRIER/NOISE**, **(Bw/Avg)**, **OFFSET FREQ**, **(1)**, **(k/m)**.
 - b. Confirm the reading value is equal to, or greater than 100 dBc. Record the result (pass or fail) as **RESULT(CN(1k))**.
 - c. Press **OFFSET FREQ**, **(1)**, **(0)**, **(k/m)**.
 - d. Confirm the reading value is equal to, or greater than 130 dBc. Record the result (pass or fail) as **RESULT(CN(10k))**.
 - e. Press **OFFSET FREQ**, **(1)**, **(0)**, **(0)**, **(k/m)**.

- f. Confirm the reading value is equal to, or greater than 140 dBc. Record the result (pass or fail) as RESULT(CN(100k)).
 - g. If one or more tests fail, note all test results, and go to the *Receiver Group Troubleshooting* Chapter.
6. Check the FM Deviation Calibration.
- a. Press **Trigger**, **TRIGGER: HOLD** to hold the measurement.
 - b. Press **Meas**, **FM DEVIATION**, **Menu**, **FM DEV CAL**, **EXECUTE DEV CAL** to perform the FM Deviation Calibration.
 - If FM DEV CAL FACTOR : XXXXXXX (X: numeric) is displayed, there is no trouble found.
 - If CAUTION: Invalid Dev Cal is displayed, go to the *Receiver Group Troubleshooting* chapter.

PERFORMANCE TESTS FAILURE TROUBLESHOOTING

Perform the following procedure sequentially when any performance tests fail.

Perform Adjustments and Correction Constants

Table 4-1 gives the recommended adjustments and correction constants when a performance test fails. If a performance test fails, you should perform the corresponding adjustments or correction constants function as shown in Table 4-1.

Table 4-1. Recommended Adjustments and Correction Constants

Failed Performance Tests	Adjustments Correction Constants (CC)
Frequency Measurement	None
RF Power Measurement	RF Power Linearity CC, RF Power Flatness CC
C/N Measurement Phase Noise	Crystal Filter Frequency Response CC
C/N Measurement Accuracy (Flatness)	Crystal Filter Frequency Response CC
C/N Measurement Accuracy (Linearity)	Crystal Filter Frequency Response CC
FM Deviation Test	Crystal Filter Frequency Response CC FV Converter CC
Spectrum Measurement Relative Level Accuracy	Crystal Filter Frequency Response CC Spectrum Measurement CC
Frequency Transient Frequency Accuracy	None
DC Power Voltage	DC Power Voltage CC
DC Control Voltage	DC Control Voltage CC
MOD OUT Voltage	MOD OUT Level CC
DC Power Current	DC Power Current CC

TROUBLESHOOTING GPIB SYSTEM

Check the analyzer's GPIB functions with a known working passive peripheral (like a printer) or the recommended signal generator.

Check the GPIB system with the signal generator

The 4352B is normally used with the following recommended signal generator as the 4352S VCO/PLL Signal Test System. The signal generator is controlled by the 4352B via GPIB cable automatically. Perform the following procedures to check the GPIB system with the signal generator.

- 8664A with Option 004
- 8644B with Option 002
- 8657B
- 8648B
- 8648C

1. Connect the signal generator using a good GPIB cable to the analyzer.
2. Turn the analyzer power on.
3. Press **(Local)**, **SYSTEM CONTROLLER**. Then press **SET ADDRESSES** and press **ADDRESS: SG** to see the signal generator addresses recognized by the analyzer. The factory default address is:

Table 4-2. Default GPIB Addresses

DEVICE	GPIB ADDRESS
Signal Generator	19

4. Set the GPIB address of the signal generator to the address that the analyzer recognizes, if required. Refer to the manual of the peripheral to read or change its address.
5. Press **(RF/LO)**, set **Lo Control auto Man** to AUTO, and press **SG TYPE**, entry keys to set the signal generator type according to the following list.

Table 4-3. SG Type

Signal Generator	SG Type
8664A	1
8644B	1
8657B	2
8648B	3
8648C	3

6. Turn the signal generator power on.
7. Press **(Preset)** of the 4352B. Then confirm the signal generator's GPIB remote indicator is lit.
 - If it passes, the GPIB function is working in the analyzer.
 - If it fails, suspect GPIB problems in the analyzer. Continue with the *Digital Control Troubleshooting* chapter.

Check the External Controller

If unexpected operations appear when controlling the analyzer with an external controller, perform the following checks to verify the problem is not within the controller.

- Compatibility, must be HP 9000 series 200/300, see the controller and the BASIC system manuals.
- GPIB interface hardware must be installed in the controller, see the controller and the BASIC system manuals.
- I/O and GPIB binaries loaded, see the BASIC system manuals.
- Select code, see the BASIC system manuals.
- GPIB cables, see the BASIC system manuals.
- Programming syntax, see the BASIC system manuals.

If the analyzer is operating in an unexpected manner after these checks are verified, continue with *Digital Control Troubleshooting* chapter.

Power Supply Troubleshooting

INTRODUCTION

Use this procedure only if you have read *Troubleshooting*, and you believe the problem is in the power supply. The procedure is designed to let you identify the bad assembly within the power supply functional group in the shortest possible time.

The power supply functional group consists of:

- A40 Pre-Regulator
- A50 DC-DC Converter
- A2 Post-Regulator
- Fan Assembly

All assemblies, however, are related to the power supply functional group because power is supplied to each assembly. For more information about the signal paths and specific connector pin numbers, see Figure 5-11, Figure 5-12, and Figure 5-13 at the end of this chapter.

If an assembly is replaced, see *Post Repair Procedures* in this manual. It tells what additional tests or adjustments need to be done after replacing any assembly.

START HERE

1. Check Error Messages

Turn the analyzer power on. If one of error messages listed below appears on the display, follow the instruction of the displayed error message. If no error message is displayed, continue with the next *Check the Fan is Rotating*.

Error Messages	Instruction
POWER FAILED ON - - -	One or some of A2 power supplies, +15 V, +8.5V, +5.3 V, +5 V, -5 V, -15 V are displayed in - - - of the message. The displayed power supplies are shut down due to the trouble on the A2 post-regulator. Continue with the <i>Check the A2 Seven LEDs</i> in this <i>START HERE</i> .
POWER FAILED ON PostRegHot	This indicates A2 power supplies, +15 V, +8.5 V, +5.3 V, +5 V, -5 V, -15 V, are shut down due to too hot heat sink on A2 post-regulator. Cool down the analyzer for about 30 minutes. Then turn the analyzer power on. If this message is still displayed, replace A2 post-regulator.

These messages are associated with the power supplies functional group. These messages indicate the A2 protective shutdown circuit is shutting down some of A2 power supplies to protect them from over current, over voltage, under voltage, and too hot conditions. For more information about the A2 shutdown circuit, see the Figure 5-12 Power Supply Block Diagram 2.

Note



These messages are displayed only after the power on sequence. In the power on sequence, the analyzer checks the shutdown status of the A2 power supplies, +15 V, +5 V, -5 V, -15 V. If a power supply is shut down, the analyzer displays an error message and stops its operation. Once the analyzer stops the operation, any front key operations are disabled. The only way to reset the analyzer is turning the analyzer power off.

2. Check the Fan is Rotating

Look at the fan on the rear panel. Check the fan is rotating.

- If the fan is not rotating, continue with the *FIND OUT WHY THE FAN IS NOT ROTATING* in this chapter.
- If the fan is rotating, continue with the next *Check the A50 SHUTDOWN LED*.

3. Check the A50 SHUTDOWN LED

There is a LED, SHUTDOWN LED, on the A50 DC-DC Converter. Perform the following procedure to check it. The SHUTDOWN LED is described in the next *A50 Shutdown LED*.

- Turn the analyzer power off.
- Remove the analyzer's top cover and shield plate.
- Turn the analyzer power on.
- Look at the A50 SHUTDOWN LED. The LED is normally on. The SHUTDOWN LED location on A50 DC-DC Converter is shown in Figure 5-1.

- If the A50 SHUTDOWN LED is off, check the cable connection between A50J2 and A2J4. If the connection is good, continue with the *FIND OUT WHY THE A50 SHUTDOWN LED IS OFF* in this chapter.
- If the A50 SHUTDOWN LED is on, continue with the *Check the A1 +5 VD LED* in this procedure.

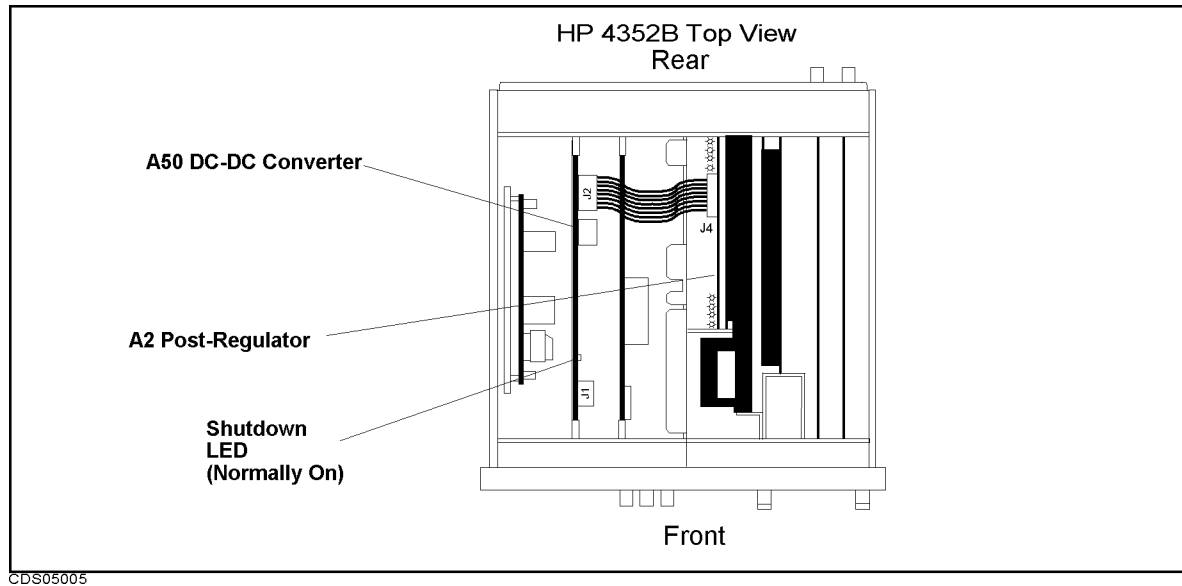

Figure 5-1. A50 SHUTDOWN LED Location

A50 Shutdown LED

The A50 SHUTDOWN LED turning off indicates some of A50 power supply is shut down by the A50 shutdown circuitry.

There are two FAN conditions, rotating and not rotating when the SHUTDOWN LED turns off. When the fan is rotating, the shutdown circuit is probably activated by the over current condition on the power lines in the A50 DC-DC Converter or the A2 Post Regulator. In this condition, though the A50 power supplies, +5 VD, +18 V, +7.8 V, -7.8 V, and -18 V are shut down, the Fan Power +24 V is still supplied to the fan. When the fan is not rotating, the shutdown circuit is probably activated by the FAN LOCK signal missing.

For more information about the A50 shutdown circuit operation, see the Figure 5-11 Power Supply Block Diagram 1.

Note



Once the A50 shutdown circuit is activated, the only way to reset the circuit is turning the analyzer power off. Wait a minute after turning the analyzer off. Then turn it on.

4. Check the A1 +5 VD LED

- a. Remove the analyzer's bottom cover.
- b. Turn the analyzer power on.
- c. Look at the +5 VD LED. The +5 VD LED location on A1 CPU is shown in Figure 5-2. The LED is normally on.
 - If the +5 VD LED is off, continue with the *FIND OUT WHY THE A1 +5 VD LED IS NOT ON STEADILY* in this chapter.
 - If the +5 VD LED is on, the +5 VD power supply is verified with 95% confidence level. Continue with the *Check A2 Seven LEDs* in this procedure. If you want to confirm the last 5% uncertainty, perform steps in the next *Measure the A1 +5 VD Voltage*.

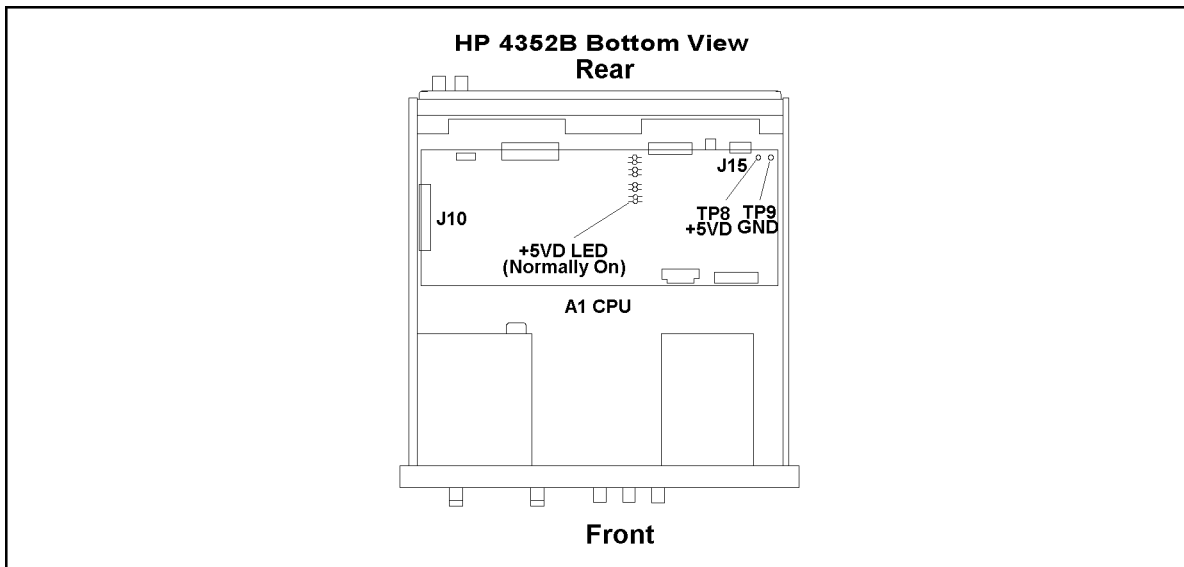

CDS05006

Figure 5-2. A1 +5 VD LED Location

Measure the A1 +5 VD Voltage

Measure the DC voltage on a test point A1TP8 (+5 VD) using a voltmeter. Check the voltmeter reading is within 4.59 V to 5.61 V.

- If the voltmeter reading is out of the limits, continue with the *FIND OUT WHY THE A1 LED IS NOT ON STEADILY*.
- If the voltmeter reading is within the limits, continue with the next step.

5. Check the A2 Seven LEDs

- a. Remove the analyzer's top cover and shield.
- b. Turn the analyzer power on.
- c. Look at the A2 Seven LEDs. The A2 Seven LED locations are shown in Figure 5-3. Check the LEDs are correctly on.
 - If two or more LEDs are off, continue with the *TROUBLESHOOT A2 POST-REGULATOR* in this chapter.
 - If the LEDs are correctly on, continue with the next *Run the Internal Test 4: A2 POST REGULATOR*.

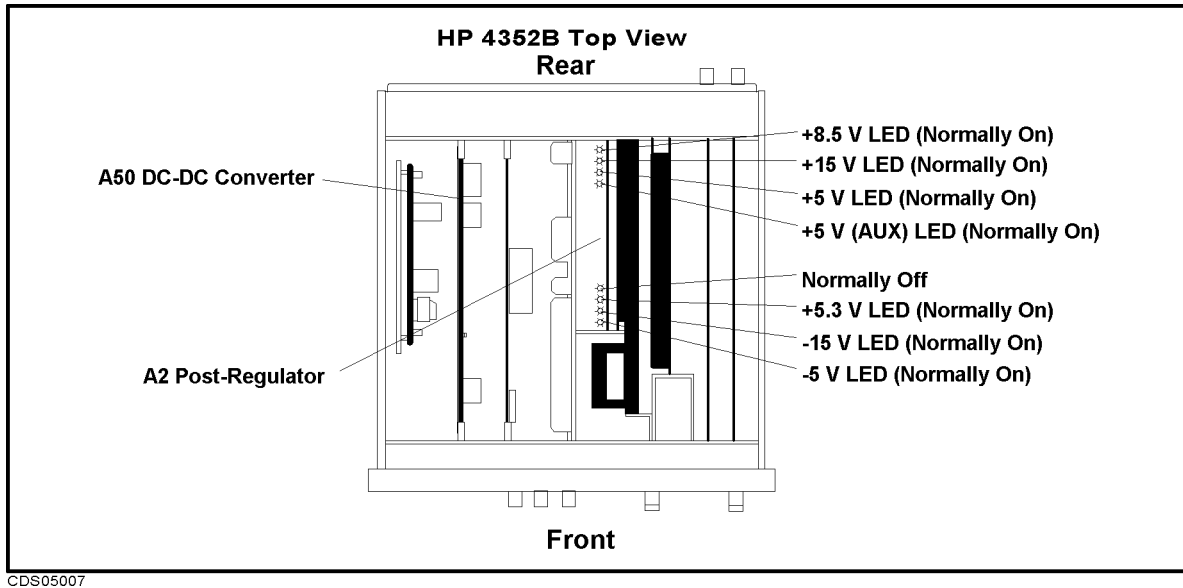

Figure 5-3. A2 Eight LED Locations

6. Run the Internal Test 4: A2 POST REGULATOR

The internal test 4: A2 POST REGULATOR verifies the A2 post-regulator. Perform the following procedure to check the A2 post-regulator. The internal test 4 is described in the next *Internal Test 4: A2 POST REGULATOR*.

Press **System**, **SERVICE MENU**, **TESTS**, **4**, **x1**, **EXECUTE TEST** to execute the internal test 4: A2 POST REGULATOR. After the test completed, the test result is displayed as shown in Figure 5-4.

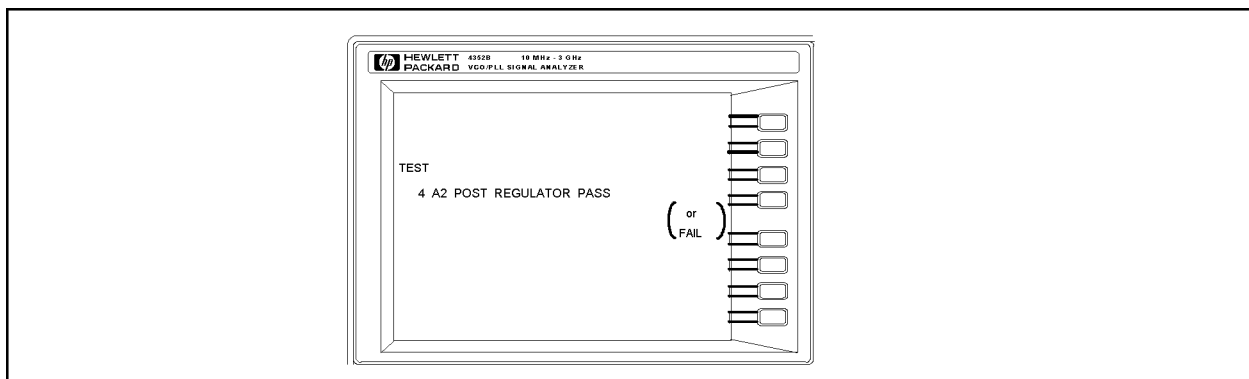

Figure 5-4. Displayed Test Result

- If “PASS” is displayed, the power supply function group are working properly with a 95% confidence level. To confirm the last 5% uncertainty of the A2 power supplies, measure the all A2 power supply voltages. See the *Measure A2 Post Regulator Output Voltages* at the end of this chapter.
- If “FAIL” is displayed, perform the following steps.
 - a. Press **RETURN**, **SERVICE MODES**, **BUS MEAS [0N]**, **DC BUS**. Then the abbreviated faulty power supply is displayed on the LCD.

- b. Continue with the *TROUBLESHOOT A2 POST-REGULATOR* in this chapter. In particular, check the faulty power supply.

Internal Test 4: A2 POST REGULATOR

The internal test 4: A2 POST REGULATOR is a built-in diagnostics test. The test checks all A2 power supply voltages within the limits using the DC BUS and the A/D converter on the A6 receiver IF. If a power supply failure is found, the analyzer stops the test process and displays the test result as shown in Figure 5-4. For more information about the internal test and the DC BUS, see the *Service Key Menu* chapter in this manual.

FIND OUT WHY THE FAN IS NOT ROTATING

If the fan is not rotating, the problem may be in the A40 pre-regulator, the A50 DC-DC Converter, the A2 post-regulator, or the fan.

1. Check the Line Voltage, Selector Switch Setting, and Fuse

Check the main power line cord, line fuse, and actual line voltage to see that they are all correct. Figure 5-5 shows how to remove the line fuse, using a small flat-bladed screwdriver to pry off the fuse holder. For more information about the line cord and line fuse, see the *Power Requirements* in Appendix B.

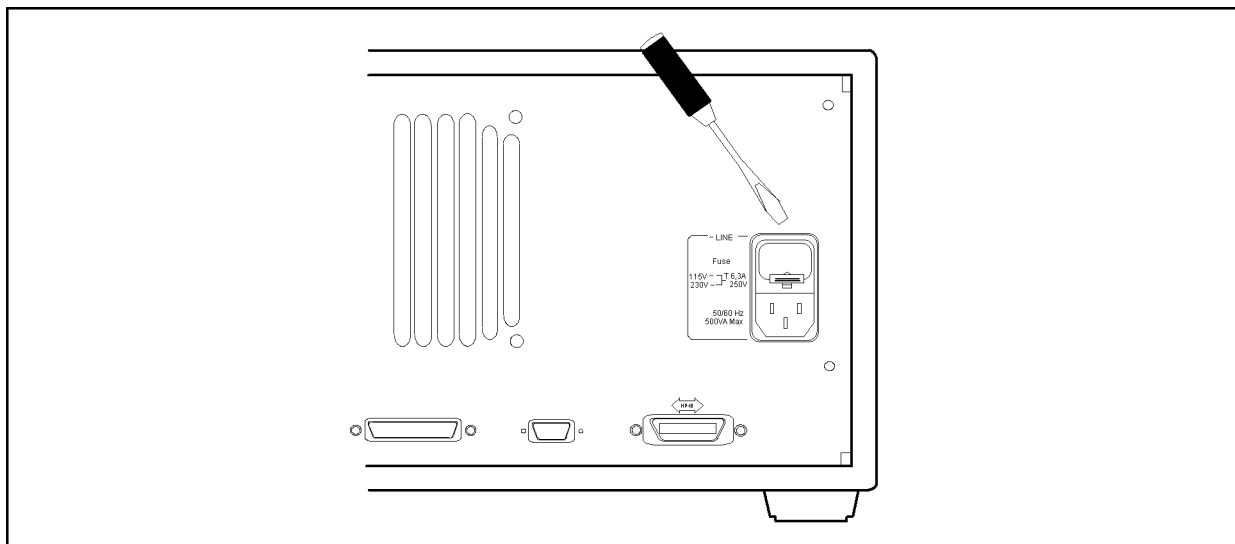

CDS05010

Figure 5-5. Removing Line Fuse

2. Check the A50 SHUTDOWN LED

When the fan stops, the A50 SHUTDOWN LED is off. See the Figure 5-11 Power Supply Block Diagram 1. The fan generates a FAN LOCK signal. The signal is fed into the FAN LOCK SENSE circuit in the A50 DC-DC converter. If the FAN stops, the FAN LOCK signal is missing. Then the FAN LOCK SENSE circuit activates the A50 shutdown circuitry, resulting the SHUTDOWN LED turned off.

Perform the following procedure to check the A50 SHUTDOWN LED on.

- a. Remove the analyzer's top cover and shield plate.
- b. Make sure the A2 post-regulator is firmly seated and the cables are connected properly.
- c. Turn the analyzer power on.
- d. Look at the A50 SHUTDOWN LED. The LED location is shown in Figure 5-1.
 - If the SHUTDOWN LED is on, replace the A50 DC-DC Converter.
 - If the SHUTDOWN LED is off, check the cable connection between A50J2 and A2J4. If the connection is good, continue with the *TROUBLESHOOT THE FAN AND THE A50 DC-DC CONVERTER* in this chapter.

FIND OUT WHY THE A50 SHUTDOWN LED IS OFF

Use this procedure when the fan is rotating.

If the fan is rotating, the A50 SHUTDOWN LED turning off indicates the A50 shutdown circuit is protecting the +5 VD power supply from the over voltage condition. The +5 VD power line may be shorted with one of power lines higher than +5 V. The problem may be in the A50 DC-DC Converter, the A2 post-regulator, and any of assemblies obtaining the power from +5 VD supply and the higher power supplies.

1. Disconnect the Cable from the A50J3

Turn the analyzer power off. Disconnect the cable from the A50J3. Turn the analyzer power on.

- If the A50 SHUTDOWN LED is still off, replace the A50 DC-DC Converter.
- If the A50 SHUTDOWN LED goes on, the A50 DC-DC Converter is verified. Turn the analyzer power off and reconnect the cable to the A50J3. Continue with the next *Disconnect the Cable from the A1J10*.

2. Disconnect the Cable from the A1J10

Turn the analyzer power off. Disconnect the cable from A1J10. Turn the analyzer power on.

- If the A50 SHUTDOWN LED is still off, replace the A1 CPU.
- If the A50 SHUTDOWN LED goes on, the A1 CPU is verified. Turn the analyzer power off and reconnect the cable to the A1J10. Continue with the next *Remove Assemblies*.

3. Remove Assemblies

- a. Turn the analyzer power off.
- b. Remove the assemblies, A3, A5, A6, A13, A17, A60 and A70. Don't remove the A2 post-regulator.
- c. Turn the analyzer power on.
 - If the A50 SHUTDOWN LED is still off, the A2 post-regulator is probably faulty. Replace the A2 post-regulator. If the SHUTDOWN LED is still off after replacing the A2 post-regulator, inspect the A20 motherboard for soldering bridges and shorted traces on the FAN POWER and the FAN LOCK signal paths.
 - If the A50 SHUTDOWN LED goes on, the A2 post-regulator and the A20 motherboard are verified. Continue with the next step.
- d. Reinstall each assembly one at a time. Turn the analyzer power on after each is installed. The assembly that causes the A50 SHUTDOWN LED to go on is the most probable faulty assembly. Replace the assembly.

FIND OUT WHY THE A1 +5 VD LED IS NOT ON STEADILY

If the +5 VD LED is not on steadily, the +5 VD line voltage is missing or is not enough to power the analyzer. The problem may be in the A40 pre-regulator, the A50 DC-DC Converter, the A1 CPU, and any of assemblies obtaining the power from +5 VD supply.

1. Check the A40 Pre-Regulator

- a. Turn the analyzer power off.
- b. Disconnect a cable form the A50J1. The A50J1 location is shown in Figure 5-6.
- c. Turn the analyzer power on.
- d. Check the voltage between the pin 1 and pin 6(GND) of the cable within +22.0 V to +27.0 V using a voltmeter with a small probe.
 - If the voltmeter reading is out of the limits, replace the A40 pre-regulator.
 - If the voltmeter reading is within the limits, the A40 pre-regulator is verified. Turn the analyzer power off and reconnect the cable to the A50J1. Then continue with the next *Check the A50 DC-DC Converter* section.

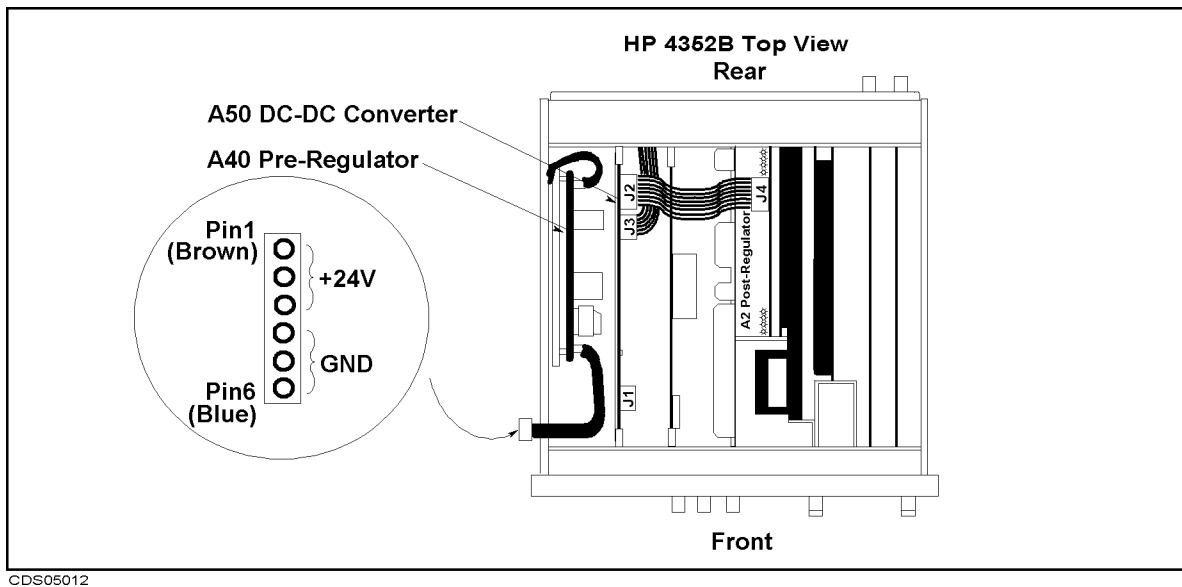

Figure 5-6. A40J1 Output Voltage

2. Check the A50 DC-DC Converter

- a. Turn the analyzer power off.
- b. Disconnect a cable form the A50J3. The A50J3 location is shown in Figure 5-6.
- c. Turn the analyzer power on.
- d. Check the voltage between the A50J3 pin 1 and pin 6(GND) within +4.59 V to +5.61 V using a voltmeter with a small probe.
 - If the voltmeter reading is out of the limits, replace the A50 DC-DC Converter.
 - If the voltmeter reading is within the limits, the A50 DC-DC Converter is verified. Turn the analyzer power off and reconnect the cable to the A50J3. Then continue with the next *Disconnect Cables on the A1 CPU* section.

3. Disconnect Cables on the A1 CPU

- a. Turn the analyzer power off.
- b. Disconnect cables from the A1 CPU's connectors, J10, J11, J12, J13, J14, J16, and J17. Don't disconnect the A1J15. The connector locations are shown in Figure 5-7

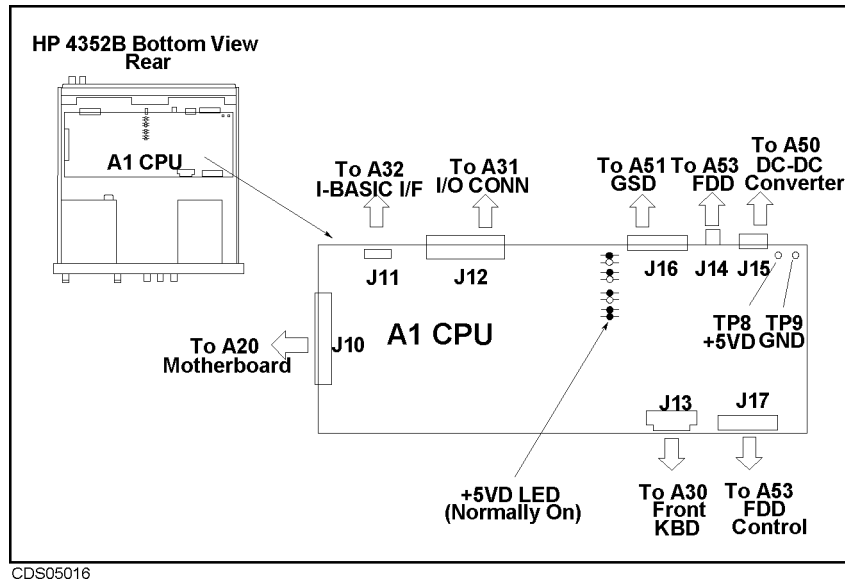

Figure 5-7. A1 CPU Connector Locations

- c. Turn the analyzer power on. Look at the A1 +5 VD LED.
 - If the LED is still off, the A1 CPU is probably faulty. Replace the A1 CPU.
 - If the LED goes on, the A1 CPU is verified. Continue with the next step.
- d. Turn the analyzer power off. Reconnect the cable to the A1J10. Turn the analyzer power on. Look at the A1 +5 VD LED.
 - If the +5 VD LED goes off, the problem may be in the analog assemblies. Continue with the next *Remove Assemblies*.
 - If the +5 VD LED is still on, continue with the next step.
- e. Reconnect one of the disconnected cables to its connector at a time. Turn the analyzer power on after each cable is connected. The assembly related with the cable turning the +5 VD LED off is probably faulty. Replace the assembly.

4. Remove Assemblies

- a. Turn the analyzer power off. Remove the assemblies, A3, A5, A6, A13, A17, A60 and A70. Do not remove the A2 post-regulator.
- b. Turn the analyzer power on. Look at the A1 +5 VD LED.
 - If the LED is still off, replace the A2 post-regulator. If the +5 VD LED is still off after replacing the A2 post-regulator, inspect the A20 motherboard.
 - If the LED goes on, the A2 post-regulator and the A20 motherboard are verified. Continue with the next step.

- c. Reinstall one of the removed assemblies at a time. Turn the analyzer power on after each is installed. The assembly that turns the A1 +5 VD LED on is the most probable faulty assembly. Replace the assembly.

TROUBLESHOOT THE FAN AND THE A50 DC-DC CONVERTER

Perform the following procedure to troubleshoot the fan and the A50 DC-DC Converter.

1. Troubleshoot the Fan

- a. Turn the analyzer power off.
- b. Disassemble the rear panel.
- c. Remove the fan power cable from the Motherboard A20J18.
- d. Connect a DC power supply, a 10 k Ω resistance, and an oscilloscope to the fan power cable using appropriate wires as shown in Figure 5-8.

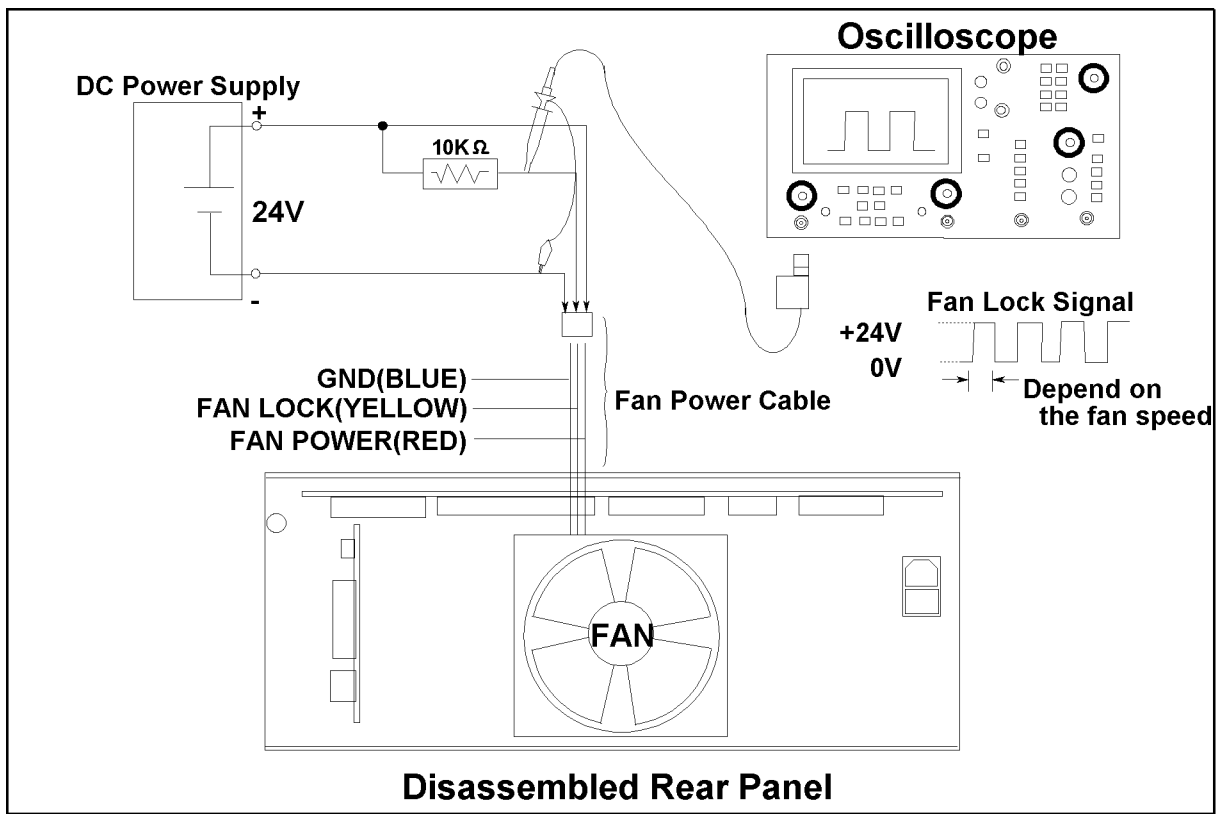

CDS05009

Figure 5-8. Fan Troubleshooting Setup

- e. Turn the DC power supply on. Adjust the output voltage to +24 V.
- f. Check the fan is rotating. Check the FAN LOCK signal is as shown in Figure 5-8.
 - If the fan is not rotating or the FAN LOCK signal is unexpected, replace the fan.
 - If these are good, the fan is verified.
- g. Reconnect the fan power cable to the Motherboard A20J18.

2. Troubleshoot the A50 DC-DC Converter

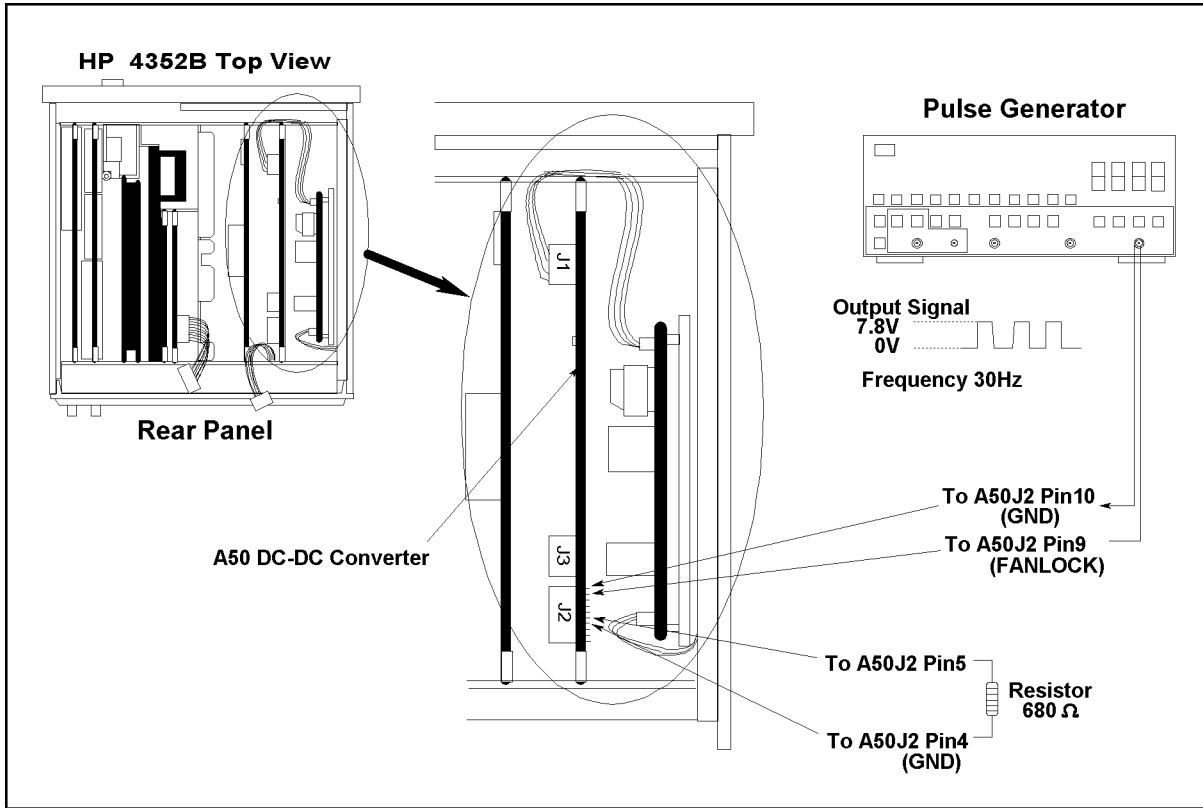

CDS05011

Figure 5-9. A50 DC-DC Converter Troubleshooting Setup

- a. Turn the analyzer power off.
- b. Disconnect cables from the A50J2 and A50J3. The connector locations are shown in Figure 5-9
- c. Connect the pulse generator to the A50J2 as shown in Figure 5-9. The pulse generator is used to feed the substitute of the FAN LOCK signal to the A50 DC-DC converter. This purposes not to shut down the A50 DC-DC converter.
- d. Turn the pulse generator power on. Set the controls as follows:

Wave Form	Square
Frequency	Approximately 30 Hz
Amplitude	+7.8 V
- e. Connect a resister (approximately 680ohms, 125mW) between the A50J2 pin 5 (+7.8 V) and pin 4(GND) as shown in Figure 5-9.
- f. Turn the analyzer power on.
- g. Measure all power supply voltages on A50J2 and A50J3 using a voltmeter with a small probe. See the Table 5-1 for power lines, connector pins, and limits.

Table 5-1. A50 Power Supplies

Supply	Connector Pin	GND Connector Pin	Range
+ 5 VD	A50J3 Pin 1, 2, and 3	A50J3 Pin 4, 5, and 6	+ 4.6 V to + 5.7 V
-18 V	A50J2 Pin 1	A50J2 Pin 3 and 4	-14.0 V to -27.0 V
+ 18 V	A50J2 Pin 2	A50J2 Pin 3 and 4	14.0 V to 27.0 V
+ 7.8 V	A50J2 Pin 5	A50J2 Pin 3 and 4	7.0 V to 9.0 V
-7.8 V	A50J2 Pin 6	A50J2 Pin 3 and 4	-6.0 V to -12.0 V
+ 24 V	A50J2 Pin 8	A50J2 Pin 10	22.0 V to 27.0 V

- If any of the power supply voltages are out of the limits, replace the A50 DC-DC Converter.
- If all A50 power supply voltages are good, the A50 pre-regulator is verified.

TROUBLESHOOT A2 POST-REGULATOR

Use this procedure when the fan is rotating and the A50 SHUTDOWN LED turns on.

If one or some of the A2 eight LEDs are not on steadily, the corresponding A2 power supply voltages, +8.5 V, +15 V, +5 V, +5 V(AUX), +5.3 V, -15 V, -5 V are missing or are not enough to power the analyzer. The problem may be in the A40 pre-regulator, the A50 DC-DC Converter, the A2 post-regulator, and any of assemblies obtaining the A2 post-regulator.

1. Measure A2 Post Regulator Output Voltages

Use this procedure to measure all A2 post-regulator voltages. If all A2 output voltages are within the limits, the A2 post-regulator is verified with 100% confidence.

This procedure put out the A2 post-regulator from the analyzer and measure the voltages on the A2J3 pins. A pulse generator is used to feed the substitute of the FAN LOCK signal to the A2 post-regulator. This purposes not to shut down the A50 DC-DC converter.

- a. Turn the analyzer power off.
- b. Remove the cable from A2J4.
- c. Remove A2 post-regulator from the analyzer.
- d. Reconnect the cable between the A2J4 and the A50J2 as shown in Figure 5-10.

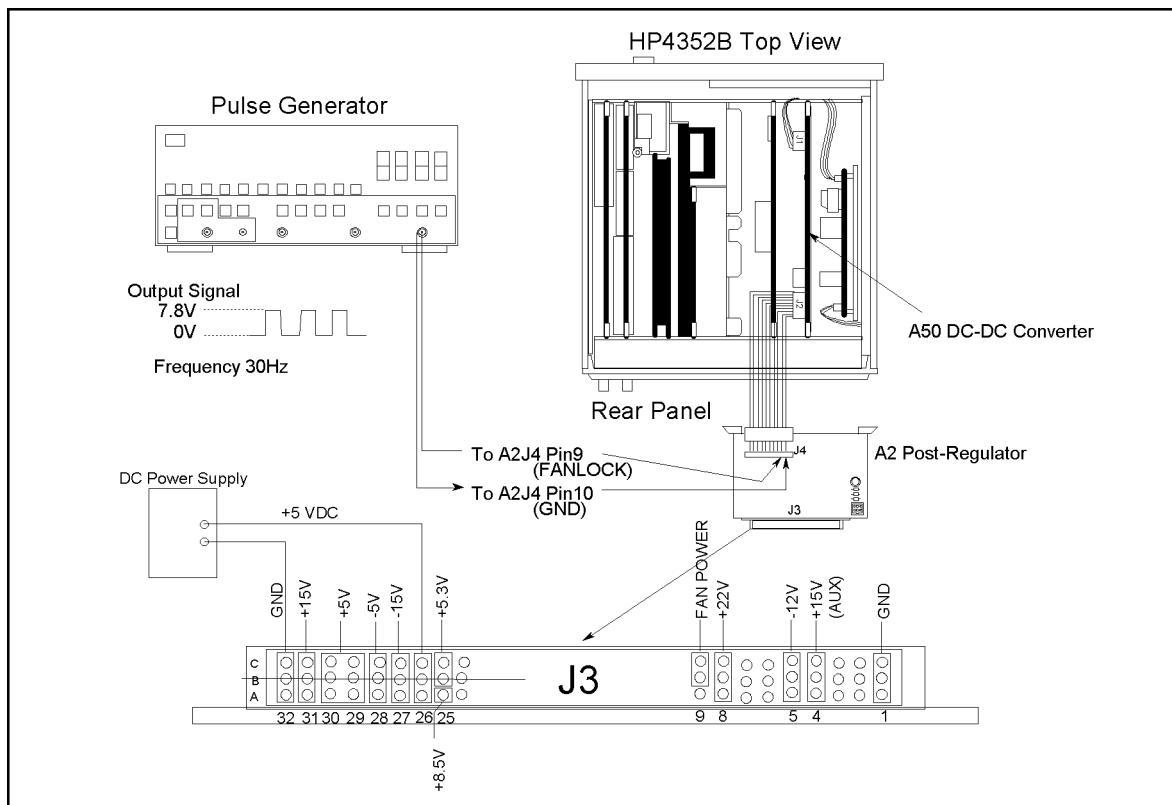

Figure 5-10. A2 Output Voltage Measurement Setup

- e. Connect the pulse generator to the A2J4 as shown in Figure 5-10.
- f. Turn the DC Power Supply on. Adjust the output voltage to +5.0 V.

g. Turn the pulse generator power on. Set the controls as follows:

Wave Form	Square
Frequency	Approximately 30 Hz
Amplitude	+7.8 V

h. Turn the analyzer power on.

i. Measure the A2 output voltages at the A2J3 pins using a voltmeter with a small probe. See Figure 5-10 and Table 5-2 for the power supplies, A2J3, and the limits.

Table 5-2. Power Supplies on A2 Post-Regulator

Supply	Connector Pin	Range
+22 V	J3 Pin 8	19.8 V to 24.2 V
+15 V(AUX)	J3 Pin 4	13.5 V to 16.5 V
+15 V	J3 Pin 31	13.5 V to 16.5 V
+8.5 V	J3 Pin 25A	7.65 V to 9.35 V
+5.3 V	J3 Pin 25B 25C	4.77 V to 5.83 V
+5 V	J3 Pin 29 30	4.5 V to 5.5 V
-5 V	J3 Pin 28	-4.5 V to -5.5 V
-12 V	J3 Pin 5	-10.8 V to -13.2 V
-15 V	J3 Pin 27	-13.5 V to -16.5 V
FAN POWER	J3 Pin 9B, 9C	19.2 V to 28.8 V
GND	J3 Pin 1, 32	

- If any of the line voltages are out of the limits, replace the A2 post-regulator.
- If all line voltages are within the limits, the A2 post-regulator is verified.

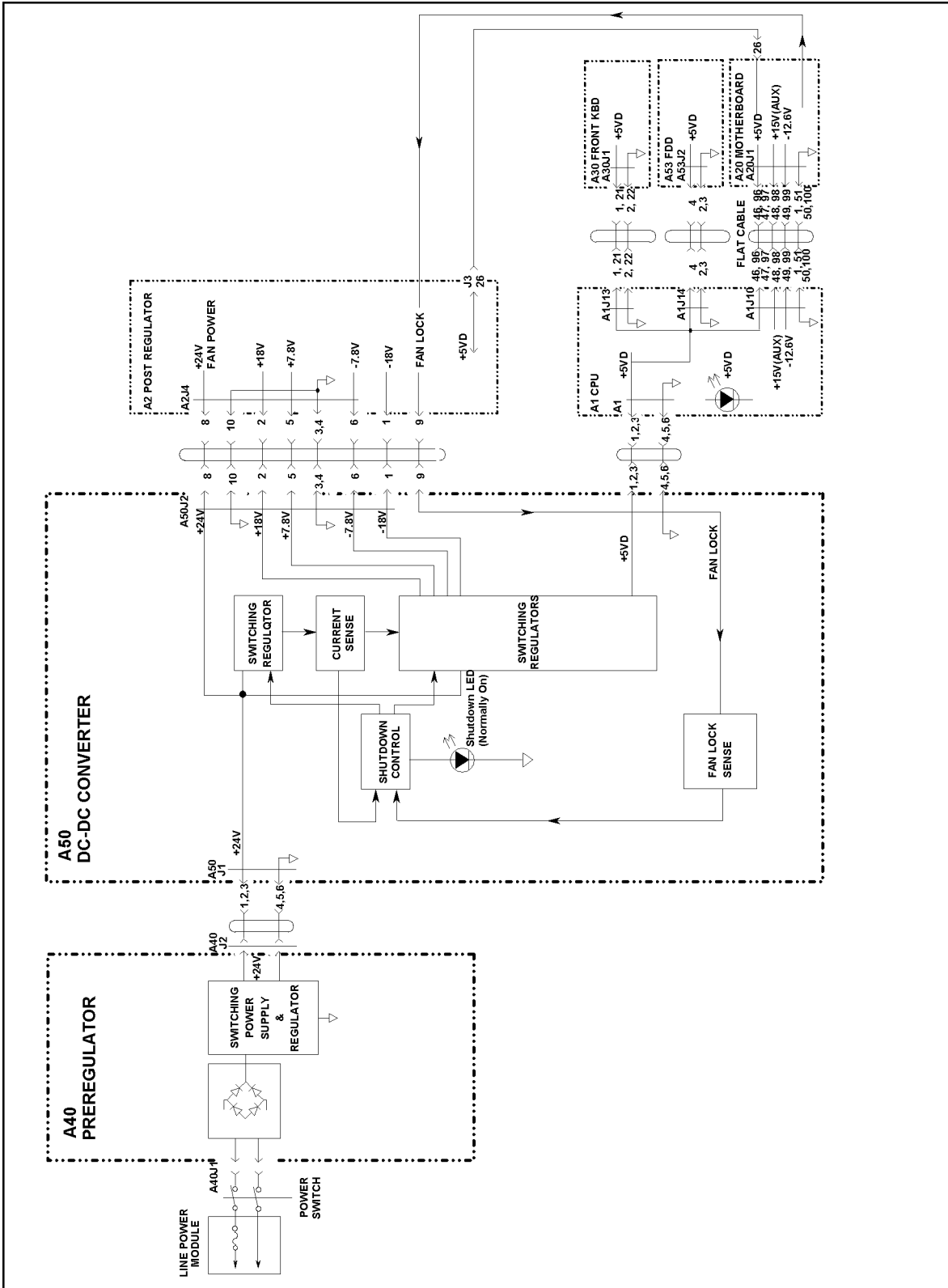

CDS05018

Figure 5-11. Power Supply Block Diagram 1

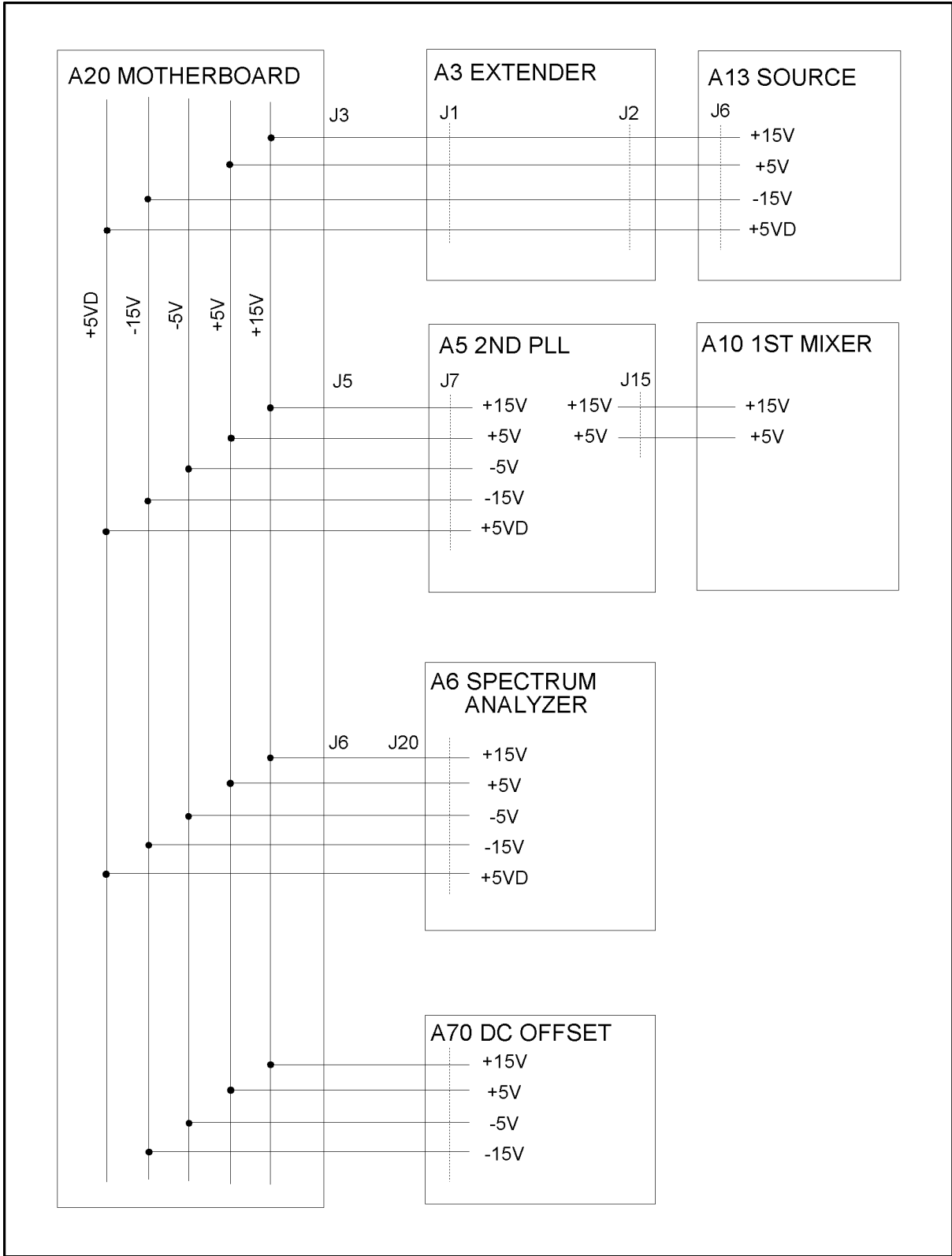

CDS05020

Figure 5-13. Power Supply Block Diagram 3

Digital Control Troubleshooting

INTRODUCTION

Use this procedure only if you have followed the procedures in the *Troubleshooting* chapter and believe the problem to be in the digital control group. This procedure is designed to let you identify the bad assembly within the digital control group in the shortest possible time. Whenever an assembly is replaced in this procedure, refer to the *Table of Related Service Procedures* in the *Post-Repair Procedures* chapter of this manual.

Figure 6-1 shows the digital control group in simplified block diagram form. The following assemblies make up the digital control group:

- A1 CPU
- A17 24 Bit I/O Port
- A30 Front Keyboard
- A31 I/O Connector
- A32 I-BASIC Interface
- A51 GSP
- A52 LCD display
- A53 FDD

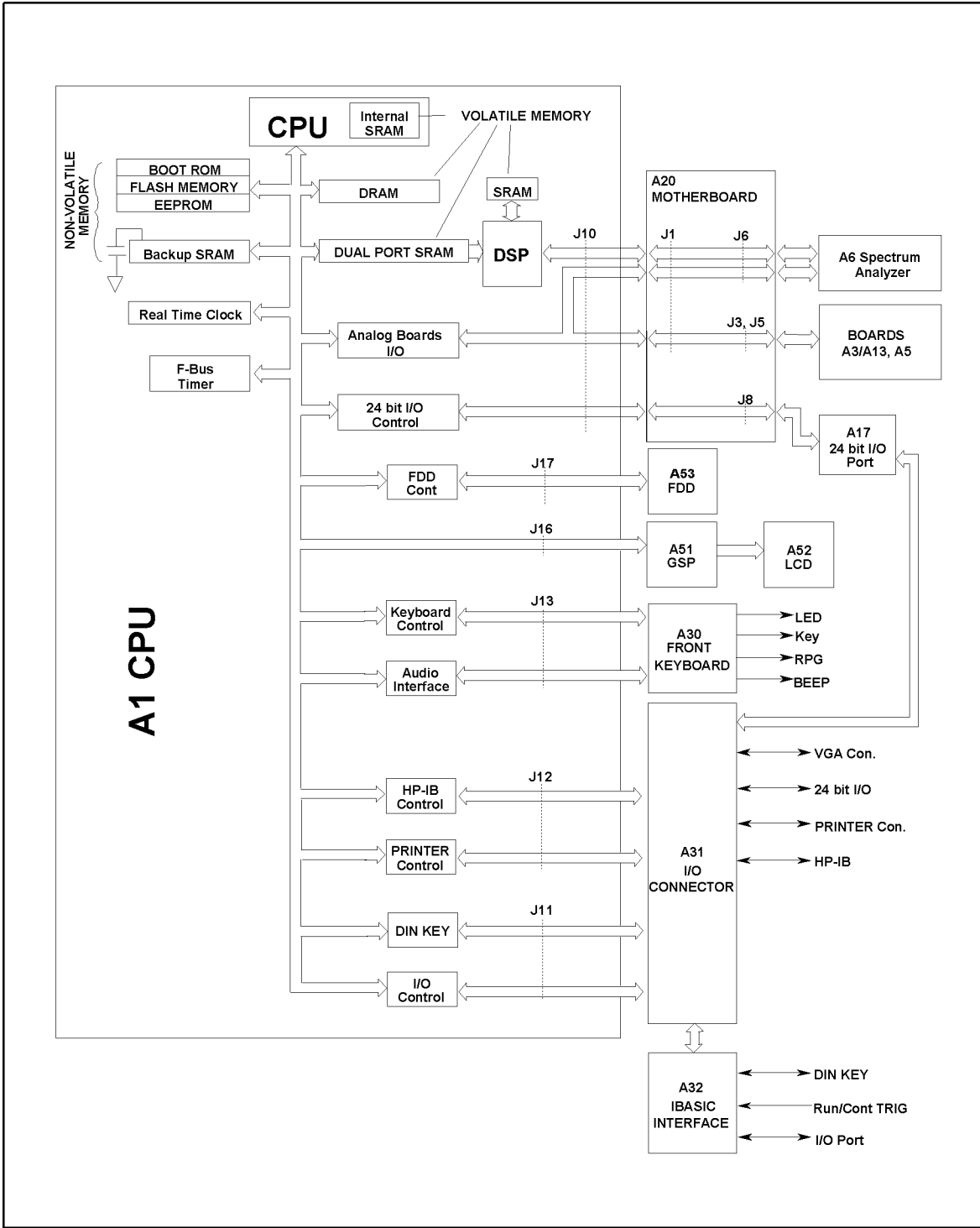

CDS06011

Figure 6-1. Digital Control Group Simplified Block Diagram

A1 CPU Replacement

When you replace a faulty A1 CPU with a new one, remove the EEPROM from the faulty A1 and mount the EEPROM on the replacement A1.

In the EEPROM, the correction constants data is stored after performing the Adjustment and Correction Constants procedures described in the chapter 2. The data may be valid for the new A1 CPU.

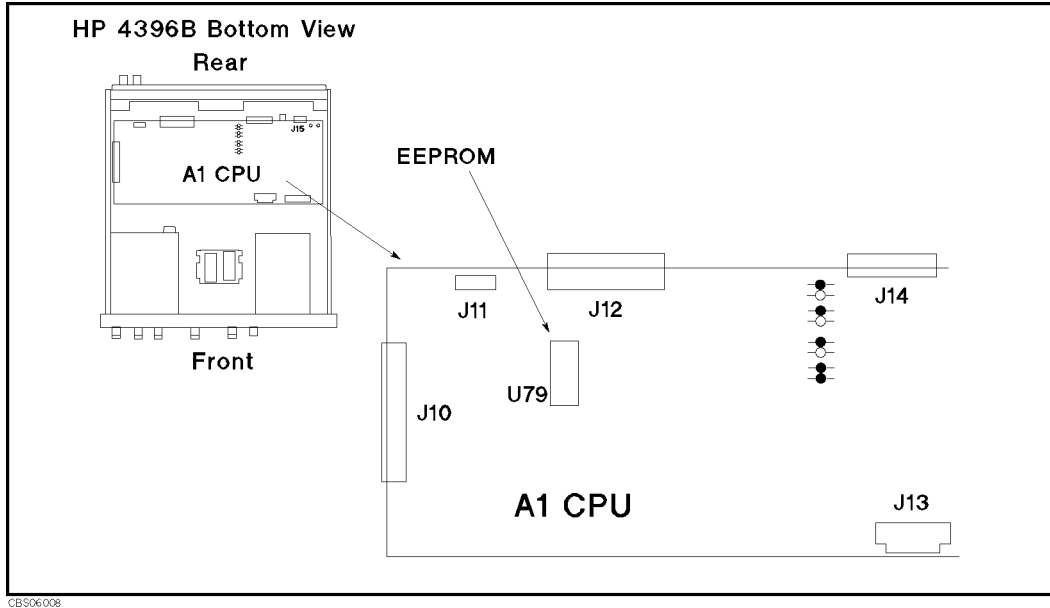

Figure 6-2. A1 EEPROM Location

FIRMWARE INSTALLATION

No firmware is installed in new A1 CPU assembly. When you replace a faulty A1 CPU with a new one, perform the following steps to install the firmware into the A1 CPU.

Ordering the Firmware Diskette

A firmware diskette (3.5 inch) that contains the analyzer's firmware is required for the firmware installation. If you do not have a Firmware Installation Kit, you must order one. For ordering information, contact your nearest Agilent Technologies service center and provide the revision of the analyzer's firmware. The part number of the Firmware Installation Kit depends on the firmware revision. The firmware revision of the analyzer is indicated on the revision label attached on the rear panel as shown in Figure 6-3.

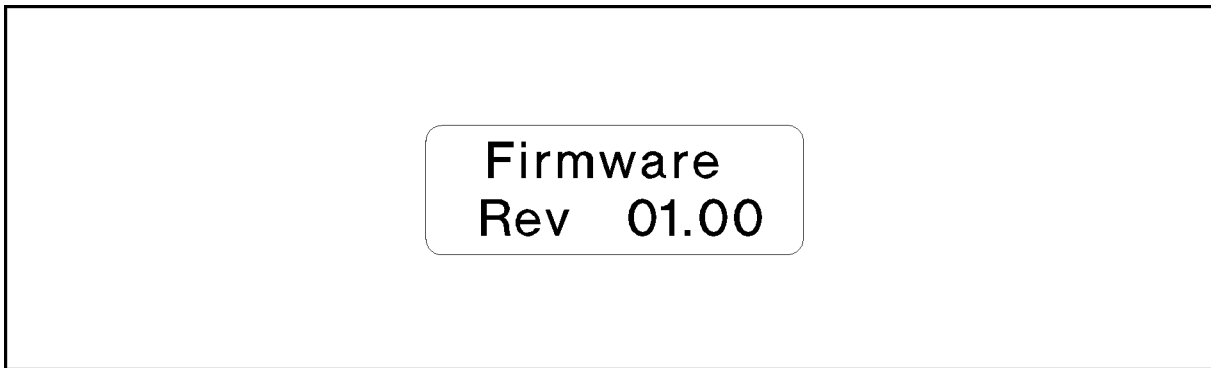

CBS06009

Figure 6-3. Firmware Revision Label

START HERE

1. Check the Power On Sequence

See the INSPECT THE POWER ON SEQUENCE in the chapter 4 for checking the Power On Sequence.

Check the A1 Eight LEDs

There are eight LEDs on the A1 CPU. These LEDs should be in the pattern shown in Figure 6-4 at the end of the power on sequence. Perform the following procedure to check the A1 eight LEDs.

- a. Turn the analyzer turn off.
- b. Remove the bottom cover of the analyzer.
- c. Turn the analyzer power on.
- d. Look at the A1 eight LEDs. Some of the LEDs light during the power on sequence. At the end of the power on sequence, the LEDs should stay in the pattern shown in Figure 6-4. If the LEDs stay in the other pattern, the A1 CPU is probably faulty. Replace the A1 CPU.

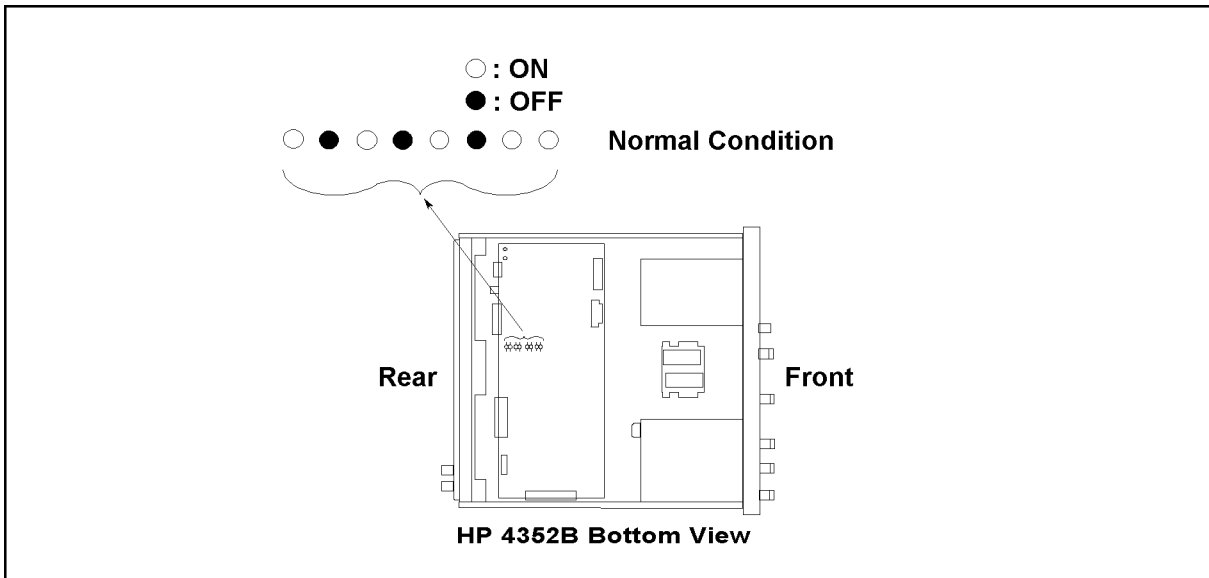

CDS06002

Figure 6-4. A1 Eight LEDs' Pattern

Check Error Messages

Turn the analyzer power on. Check that no error message appears on the LCD.

- If no error message is displayed, continue with the *Check A1 DRAM and Flash Memory* in this *START HERE* section.
- If one of error messages listed below is displayed, follow the instruction described below. For any other message, see the *Error Messages* in the Messages Chapter.

Error Messages	Instruction
EEPROM CHECK SUM ERROR	This indicates that the correction constants stored in the EEPROM on the A1 CPU are invalid or the EEPROM is faulty. Rewrite all correction constants into the EEPROM using the adjustment program. For the detailed procedure, see the <i>Adjustments and Correction Constants</i> chapter in this manual. If the rewriting is not successfully performed, replace the EEPROM and then rewrite the correction constants into the new EEPROM.
Svc (Status Annotation)	This indicates that the correction constants stored in the EEPROM on the A1 CPU are invalid or the EEPROM is faulty. See the instructions in the EEPROM CHECK SUM ERROR message, above.
CPU DRAM R/W ERROR	This indicates that the A1 DRAM Read/Write test failed on the power-on self test sequence. Replace the A1 CPU.
DUAL PORT SRAM R/W ERROR	This indicates that the power-on self test for DSP's dual port SRAM on the A1 CPU failed. Replace the A1 CPU.

Note  CAUTION: Insufficient RF Level is displayed when turning with the analyzer power on. This is caused by no RF signal input on RF IN connector of the 4352B. After the signal is input to the RF IN connector, this message will disappear.

2. Check the A1 CPU

- Turn the analyzer power on.
- Press **(System)**, **SERVICE MENU**, **TESTS**, **(1)**, **(x1)**, **EXECUTE TEST** to run the internal test 1: A1 CPU.
 - If no error message is displayed, the A1 CPU is probably good. Continue with the next step, *Check the A1 DRAM and Flask Memory*.
 - If one of the error messages listed below is displayed, the A1 CPU is faulty. Replace the A1 CPU.

FLASH MEMORY CHECK SUM ERROR
EEPROM CHECK SUM ERROR
F-BUS TIMER CHIP TEST FAILED
KEY CHIP TEST FAILED
GPIB CHIP TEST FAILED
RTC CHIP TEST FAILED
mini-DIN CHIP TEST FAILED
DSP CHIP TEST FAILED
BACKUP SRAM CHECK SUM ERROR
FDC CHIP TEST FAILED

3. Check the A1 DRAM and Flash Memory

The A1 DRAM and flash memory are tested in sequence to access the bootloader menu. For the bootloader menu, see the *Service Key Menus* chapter.

Perform the following procedure to verify the A1 DRAM and flash memory.

- a. Turn the analyzer power off.
- b. Push the two keys **DC Control** and **Preset**. While keeping the two keys pushed down, turn the analyzer power on.
- c. Wait for the display shown in Figure 6-5 to appear on the LCD.
- d. Check that no error message displayed on the LCD.
 - If no error message is displayed, the A1 DRAM and flash memories are verified. Continue with the next step, *Check the A1 Volatile Memory*.
 - If an error message is displayed or the display shown in Figure 6-5 does not appear, the A1 CPU is probably faulty. Replace the A1 CPU.

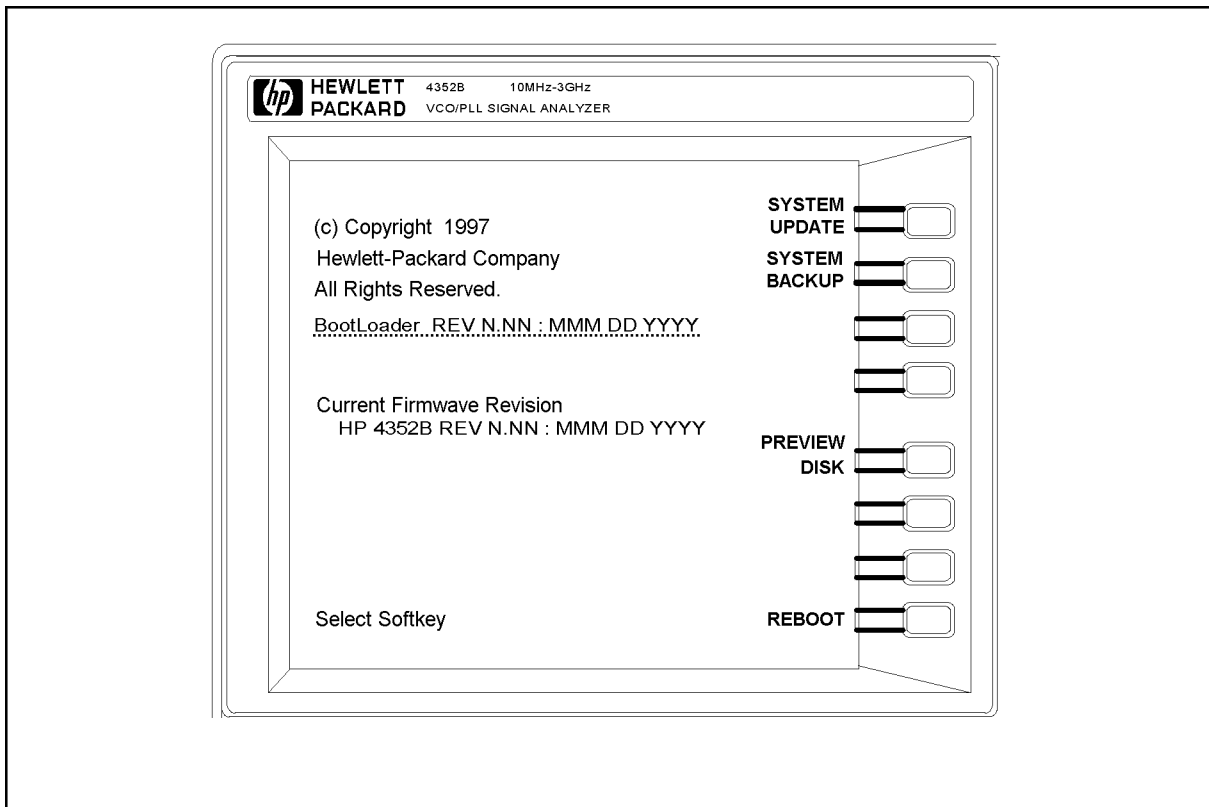

CDS14003

Figure 6-5. Bootloader Display

4. Check the A1 Volatile Memory

- a. Turn the analyzer power on.
- b. Press **(System)**, **SERVICE MENU**, **TESTS**, **(2)**, **(x1)**, **EXECUTE TEST** to run the internal test 2: A1 VOLATILE MEMORY.
- c. Check that no error message displayed. At the end of this test, the analyzer returns the control settings to their default values (power on reset). If the test fails, the analyzer displays an error message for a few seconds before setting the defaults.
 - If no error message is displayed, the A1 volatile memories are verified. Continue with the next step, *Check the A30 Front Keyboard*.
 - If one of the error messages listed below is displayed, the A1 CPU is faulty. Replace the A1 CPU.
 - CPU INTERNAL SRAM R/W ERROR
 - DSP SRAM R/W ERROR
 - DUAL PORT SRAM R/W ERROR
 - CPU BACKUP SRAM R/W ERROR

5. Check the A30 Front Keyboard

The A30 front keyboard can be checked using the external test 11: FRONT PANEL DIAG.

- a. Press **(Preset)**, **(System)**, **SERVICE MENU**, **TESTS**, **(1)**, **(1)**, **(x1)**, **EXECUTE TEST** to run the external test 17.
- b. Press all of the front panel keys. The pressed abbreviated key name should be displayed as a key is pressed. You can check every key on the A30 Keyboard except for **(Preset)**. (If you want to exit this test, press **(Preset)**.)
 - If one or more keys seems to be defective, replace the A30 front keyboard.
 - If all keys seem to be good, the A30 front keyboard is verified. Continue with the next step, *Check the A53 FDD*.

6. Check the A53 FDD

The A53 FDD (Flexible Disk Drive) can be checked using the external test 12: DISK DR FALUT ISOL'N.

- a. Press **(Preset)**, **(System)**, **SERVICE MENU**, **TESTS**, **(1)**, **(2)**, **(x1)**, **EXECUTE TEST** to run the external test 12.
- b. As the analyzer instructs, insert a flexible disk into FDD. Use a formatted but blank flexible disk, otherwise the data on the disk will be overwritten by this test. Then press **CONT**.
- c. Check the test result, PASS or FAIL, that is displayed at the end of the test.
 - If this test fails, replace the A53 FDD.

7. Check the A32 I-BASIC Interface and the mini-DIN Keyboard

Perform this procedure to verify the A32 I-BASIC interface assembly on the rear panel. The mini-DIN external keyboard is connected to the A32 I-BASIC I/O connector, and is used to develop programs.

If the mini-DIN keyboard of the I-Basic is not working, perform the following procedure to verify the mini-DIN keyboard.

Press **Ⓟ**, **Ⓢ**, **SERVICE MENU**, **TESTS**, **1**, **x1**, **EXECUTE TEST** to run the internal test 1: A1 CPU.

- If the internal test 1 passes, the mini-DIN driver circuit on the A1 CPU is probably working. Inspect the cables between the mini-DIN keyboard and the A1 CPU through the A32 I-BASIC interface. If the cable is good, replace the mini-DIN keyboard.
- If the internal test 1 fails, replace the A1 CPU.

8. Check the A17 24 bit I/O Port

Perform this procedure to verify the A17 24 bit I/O port by using the I/O Port Test Kit (PN 87510-65002).

1. Turn the analyzer off.
2. Connect the I/O Simulator to the 24 bit I/O Port on the analyzer's rear panel as shown in Figure 6-6.

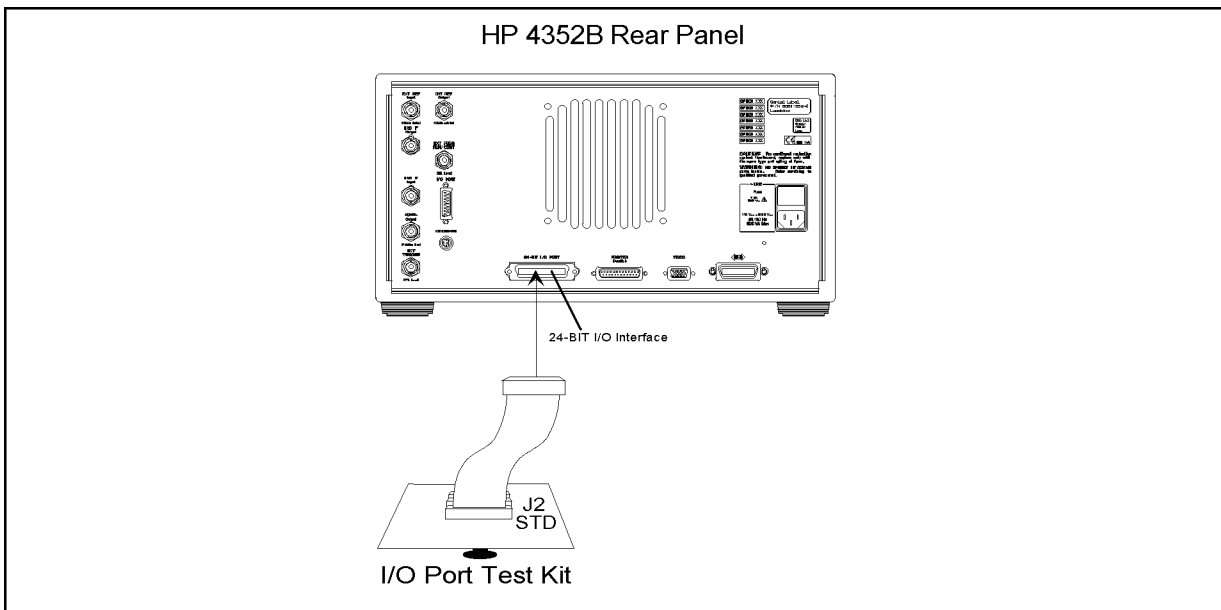

CDS06004

Figure 6-6. A17 24 bit I/O Port Test Setup

3. Turn the analyzer power on.
4. Press **Ⓢ**, **SERVICE MENU**, **TESTS**, **1**, **3**, **x1** to select the 13: 24 BIT I/O PORT test.
5. Press **EXECUTE TEST CONT** to perform this test.
 - If it fails, replace the A17 24 bit I/O port.
 - If it passes, continue with the next step.

TROUBLESHOOT THE A51 GSP and A52 LCD

Use this procedure when the LCD not acceptable, not bright or not focused.

1. Run the Internal Test 3: A51 GSP

The A51 GSP can be checked using the internal test 3: A51 GSP. If the test fails, a few beeps will sound at the end of test. Then the analyzer returns the control settings to the power-on default setting values.

- a. Press **(Preset)**, **(System)**, **SERVICE MENU**, **TESTS**, **(3)**, **(x1)**, **EXECUTE TEST** to run the internal test 3.
- b. Check the beeps at the end of the test.
 - If no beep sound, the A51 GSP is probably working. Continue with the next step, *Check the Two LEDs on A51 GSP*.
 - If the beep sounds, the A51 GSP chip is faulty. Replace the A51 GSP.
 - If two beeps sound, the A51 GSP's DRAM is faulty. Replace the A51 GSP.
 - If three beeps sound and the LED blinks three times, the A51 GSP's VRAM is faulty. Replace the A51 GSP.

2. Check the A52 LCD(Liquid Crystal Display)

The A52 LCD can be tested using the internal test 21 to 25.

- a. Press **(PRESET)**, **(SYSTEM)**, **SERVICE MENU**, **TESTS**, **(2)**, **(1)**, **(x1)**, **EXECUTE TEST** **CONTINUE** to run the internal test 21, and run the other tests with the same manner.
- b. If any defects on the LCD, replace the LCD.
- c. If no correct patterns are displayed, check the A54 Inverter.

Source Group Troubleshooting

INTRODUCTION

Use these procedures only if you have read the *Overall Troubleshooting* chapter and you believe the problem is in the source group.

This procedure is designed to let you identify a bad assembly within the source group in the shortest possible time. Whenever an assembly is replaced in this procedure, refer to the *Post-Repair Procedures* chapter.

Figure 7-1 shows a simplified block diagram of the source group. The source group consists of the following assemblies:

- A3/A13 Source
- A60 DC Source LPF
- A part of A6 Spectrum Analyzer
- A70 DC Offset (Opt. 001 only)

Note Allow the analyzer to warm up for at least 30 minutes before you perform any procedure in this chapter.



Note A3 is only an extender board which connects the A13 Source to the A20 Motherboard. Since the A3 is considered to be part of A13, the combination of the assembly numbers “A3/A13” is used.



SOURCE GROUP TROUBLESHOOTING SUMMARY

This overview summarizes the sequence of checks included in this chapter.

The source group troubleshooting flow is shown in Figure 7-2.

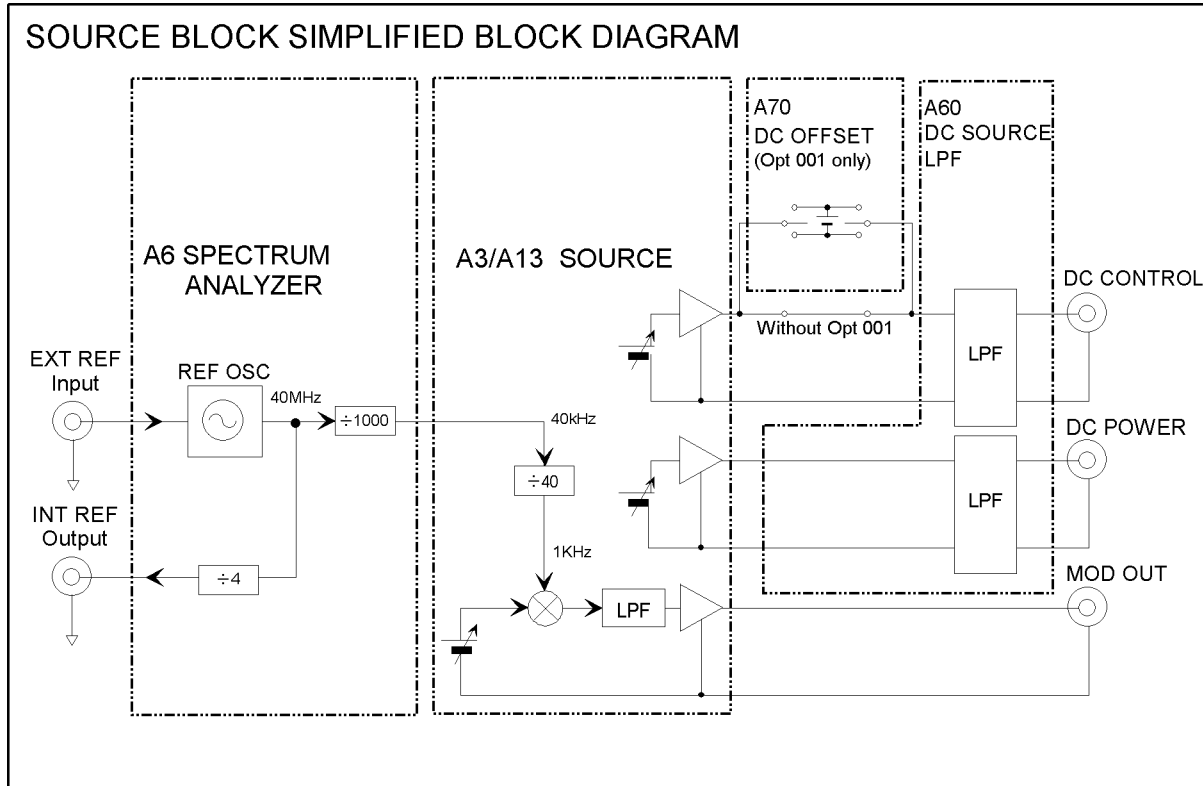

CDS07001

Figure 7-1. Source Group Block Diagram

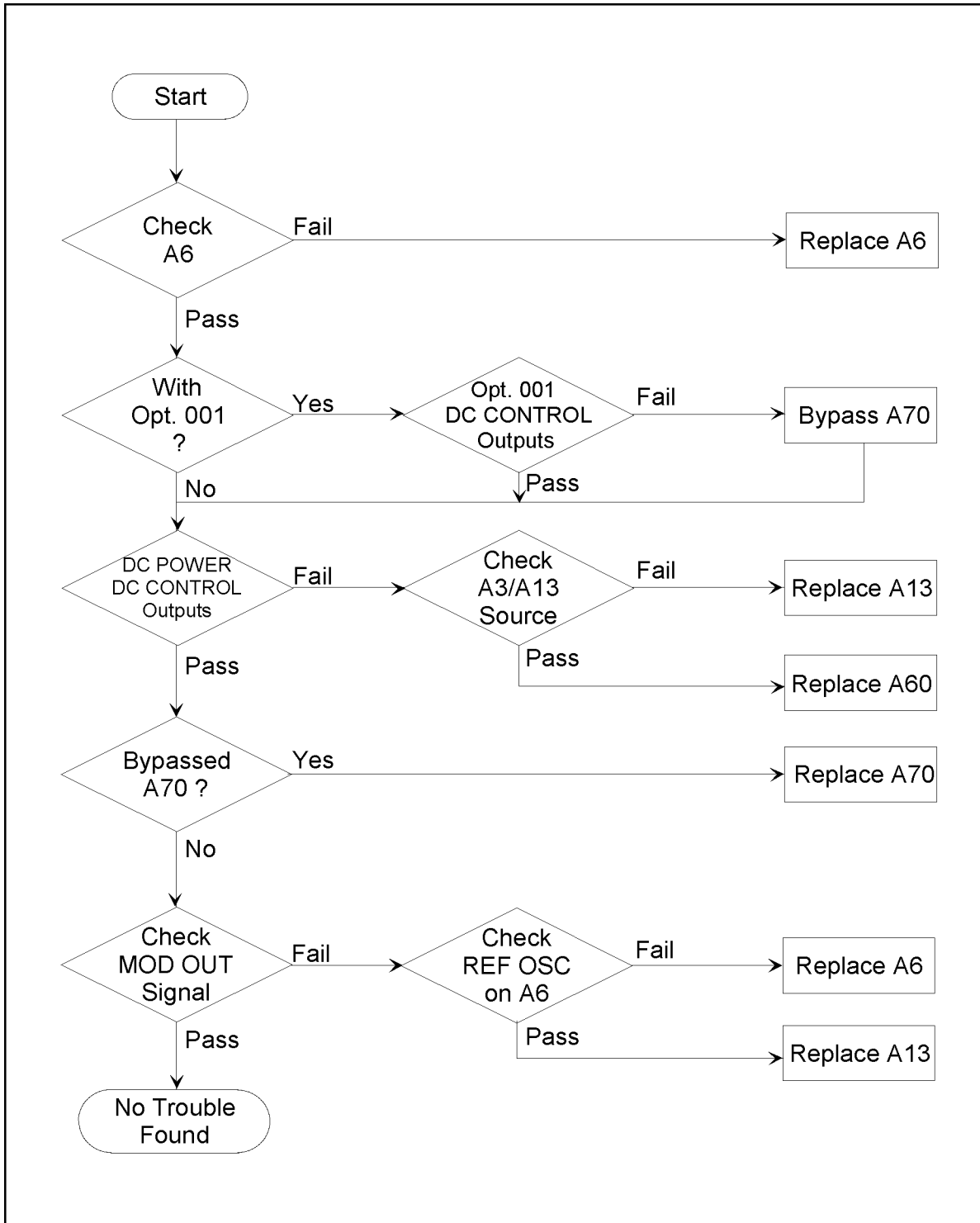

CDS07004

Figure 7-2. Source Group Troubleshooting Flow

START HERE

1. Check A6's A/D Converter

First, the A6's A/D Converter is verified because the internal tests use the A/D Converter to check voltages at DC bus nodes for the source group.

Perform the following steps to troubleshoot the source group.

1. Press **[Preset]**, **[System]**, **SERVICE MENU**, **SERVICE MODES**, **BUS MEAS [OFF]**, **DC BUS [OFF]**, **[4]**, **[0]**, **[x1]** to select DC BUS to 40: AD VREF.
2. Press **BUS MEAS** on **OFF** to activate DC BUS function.
3. Confirm that the reading value is within the range from 190 mU to 210 mU.
 - If the test fails, replace the A6 spectrum analyzer assembly.
 - if the test passes, continue with the next step.

2. Check Option 001 DC CONTROL Outputs

If the unit is equipped with the Option 001(Expand DC Control Voltage), perform the following steps to confirm the Option 001 DC CONTROL Outputs. If the unit is not equipped the Option 001, go to the *Check DC POWER/DC CONTROL Outputs*.

1. Connect the multimeter as shown in Figure 7-3.

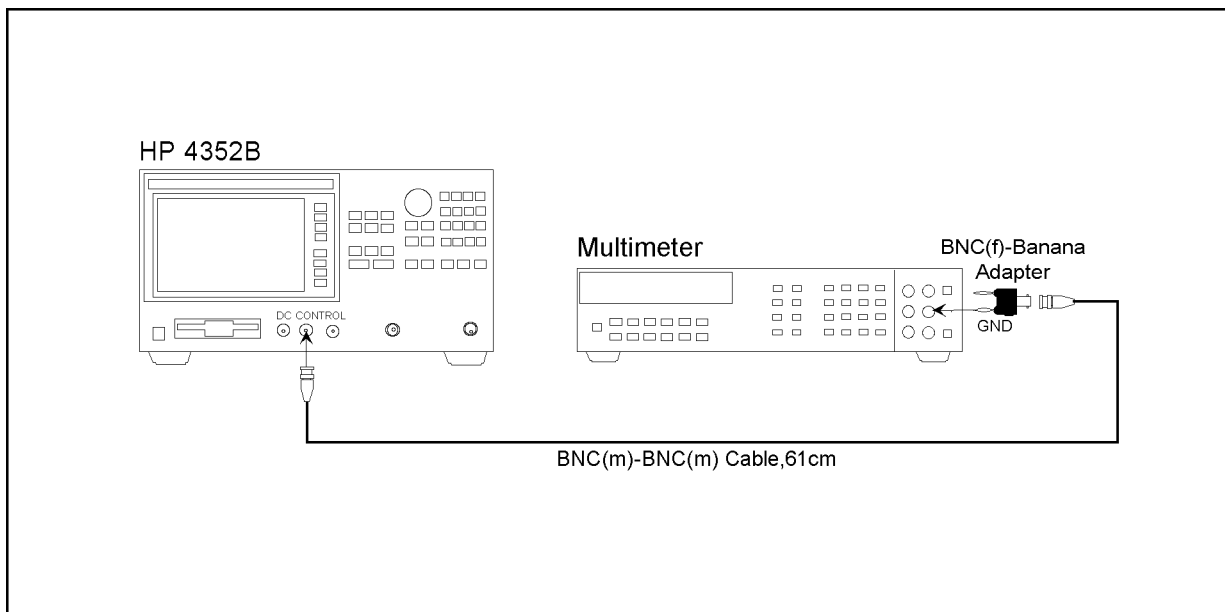

CDS02010

Figure 7-3. Option 001 DC CONTROL Output Test Setup

2. Set the multimeter to the DCV measurement mode.
3. Press **[Preset]**, **[DC CONTROL]**, **MIN CTRL VOLTAGE**, **[-]**, **[1]**, **[5]**, **[x1]** to set the minimum DC CONTROL voltage to -15 V.

4. Press **CTRL VOLTAGE**, **[-]**, **[1]**, **[5]**, **[x1]** to set the DC CONTROL voltage to -15 V. Press **OUTPUT** on **OFF** to output the DC CONTROL source.
5. Confirm that the multimeter reading value is -15 V±5 mV
6. Press **MAX CTRL VOLTAGE**, **[3]**, **[5]**, **[x1]** to set the maximum DC CONTROL voltage to 35 V.
7. Press **CTRL VOLTAGE**, **[3]**, **[5]**, **[x1]** to set the DC CONTROL voltage to 35 V. Press **OUTPUT** on **OFF** to output the DC CONTROL source.
8. Confirm that the multimeter reading value is 35 V±25 mV
 - If it fails, go to the *Bypass A70*.
 - If it passes, go to the *Check DC POWER/DC CONTROL Outputs*.

3. Bypass A70

If the unit is equipped with the Option 001 and failed the *Check Option 001 DC CONTROL Outputs*, perform the following steps. The DC CONTROL Expansion capability is eliminated because A70 DC Offset Assembly is bypassed.

1. Turn off the 4352B.
2. Remove the top cover and the top shield plate from the 4352B.
3. Unplug the “K” RF cable from the A60 Output Filter Assembly and another “K” RF cable from A13 DC FM Source Assembly. See Figure 11-35, 11-36 and 11-42 to identify the cables and assemblies.
4. Connect a RF cable Agilent P/N 04352-61616 between the “K” connector of A60 and the “K” connector of A13.
5. Go to the *Check DC POWER/DC CONTROL Outputs*.

4. Check DC POWER/DC CONTROL Outputs

Perform the following steps to confirm the DC POWER/DC CONTROL Outputs.

1. Connect the multimeter as shown in Figure 7-4.

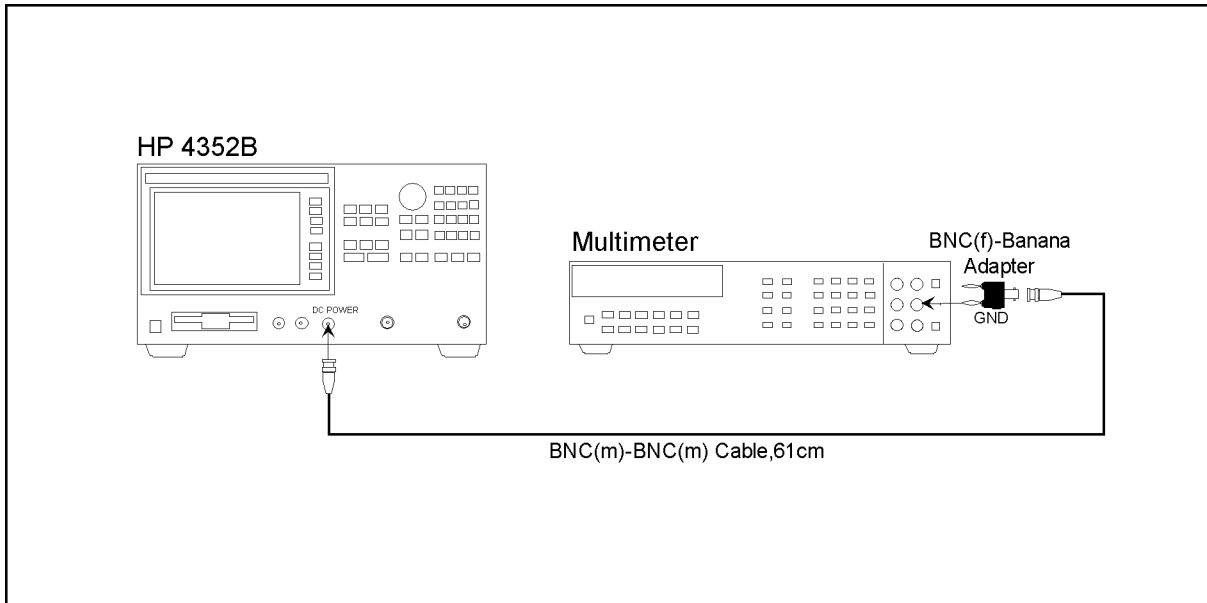

CDS02009

Figure 7-4. DC POWER Output Test Setup

2. Set the multimeter to the DCV measurement mode.
3. Press **[Preset]**, **[DC Power]**, **POWER VOLTAGE**, **[1]**, **[5]**, **[.]**, **[5]**, **[x1]** to set the DC POWER voltage to 15.5 V. Press **OUTPUT off ON** to output the DC POWER source.
4. Confirm that the multimeter reading value is 15.5 V \pm 33 mV.
 - If it fails, go to the *Check A3/A13 Source*.
 - If it passes, continue with the next step.
5. Press **OUTPUT ON off** to turn the DC POWER output off.
6. Remove the BNC connector from the DC POWER connector, and connect the BNC cable to the DC CONTROL connector.
7. Press **[DC Control]**, **CTRL VOLTAGE**, **[2]**, **[0]**, **[x1]** to set the DC CONTROL voltage to 20 V. Press **OUTPUT on OFF** to output the DC CONTROL source.
8. Confirm that the multimeter reading value is 20 V \pm 22 mV.
 - If it fails with eliminating A70 DC Offset(Opt.001 only), A70 was verified. Reinstall the A70 and go to the *Check A3/A13 Source*.
 - If it passes with eliminating A70 DC Offset(Opt.001 only), replace A70. If it passes and not equipped with the option 001, go to the *Check MOD OUT Signal*.

5. Check A3/A13 Source

Perform the following steps to confirm the A3/A13 Source by using the DC BUS function.

1. Make an OPEN condition at both DC POWER and DC CONTROL connectors.
2. Perform the following steps to check the DC-DC Converter on the A13.
 - a. Press **[Preset]**, **[System]**, **SERVICE MENU**, **SERVICE MODES**, **BUS MEAS [OFF]**, **DC BUS [OFF]**, **[2]**, **[0]**, **[x1]**, **BUS MEAS on OFF**. Confirm that the marker reading value on the upper right corner is $2.0\text{ U} \pm 0.2\text{ U}$. Record the result (pass or fail) as RESULT(20).
 - b. Press **[2]**, **[1]**, **[x1]**. Confirm that the marker reading value is $-0.5\text{ U} \pm 0.05\text{ U}$. Record the result (pass or fail) as RESULT(21).
 - c. Press **[2]**, **[2]**, **[x1]**. Confirm that the marker reading value is $+2.5\text{ U} \pm 0.2\text{ U}$. Record the result (pass or fail) as RESULT(22).
 - d. Press **[2]**, **[3]**, **[x1]**. Confirm that the marker reading value is $-0.5\text{ U} \pm 0.05\text{ U}$. Record the result (pass or fail) as RESULT(23).
3. Perform the following steps to check the DC power function via DC BUS.
 - a. Press **[Preset]**, **[System]**, **SERVICE MENU**, **SERVICE MODES**, **CORRECTION CONSTANTS**, **DCPOW VOLT ON off** so as not to activate the DC POWER Output Correction Constants.
 - b. Press **[System]**, **SERVICE MENU**, **SERVICE MODES**, **BUS MEAS [OFF]**, **DC BUS [OFF]**, **[2]**, **[4]**, **[x1]**, **BUS MEAS on OFF** to select the 24: [A3] DC POWER.
 - c. Press **[DC Power]**, **POWER VOLTAGE**, **[0]**, **[x1]**, **OUTPUT on OFF**. Confirm that the marker reading value on the upper right corner is $0\text{ U} \pm 0.01\text{ U}$. Record the result (pass or fail) as RESULT(24(0)).
 - d. Press **POWER VOLTAGE**, **[1]**, **[5]**, **[x1]**. Confirm that the marker reading value is $1.5\text{ U} \pm 0.1\text{ U}$. Record the result (pass or fail) as RESULT(24(15)).
4. Perform the following steps to check the DC control function via DC BUS.
 - a. Press **[Preset]**, **[System]**, **SERVICE MENU**, **SERVICE MODES**, **CORRECTION CONSTANTS**, **DCCTL VOLT ON off** so as not to activate the DC CONTROL output voltage Correction Constants.
 - b. Press **[System]**, **SERVICE MENU**, **SERVICE MODES**, **BUS MEAS [OFF]**, **DC BUS [OFF]**, **[2]**, **[5]**, **[x1]**, **BUS MEAS on OFF** to select the 25: [A3] DC CONTROL.
 - c. Press **[DC Control]**, **CTRL VOLTAGE**, **[0]**, **[x1]**, **OUTPUT ON off**. Confirm that the marker reading value on the upper right corner is $0\text{ U} \pm 0.01\text{ U}$. Record the result (pass or fail) as RESULT(25(0)).
 - d. Press **CTRL VOLTAGE**, **[2]**, **[0]**, **[x1]**. Confirm that the marker reading value is $2.0\text{ U} \pm 0.1\text{ U}$. Record the result (pass or fail) as RESULT(25(20)).
5. Decide which assembly is faulty according to the following guideline.
 - If all results (RESULT(20) through RESULT (25(20))) are “PASS”, replace the A60 DC Source LPF assembly.
 - If one or more results are “FAIL”, replace the A13 source assembly.

6. Check MOD OUT signal

Perform the following steps to confirm the MOD OUT signal.

1. Connect the multimeter as shown in Figure 7-5.

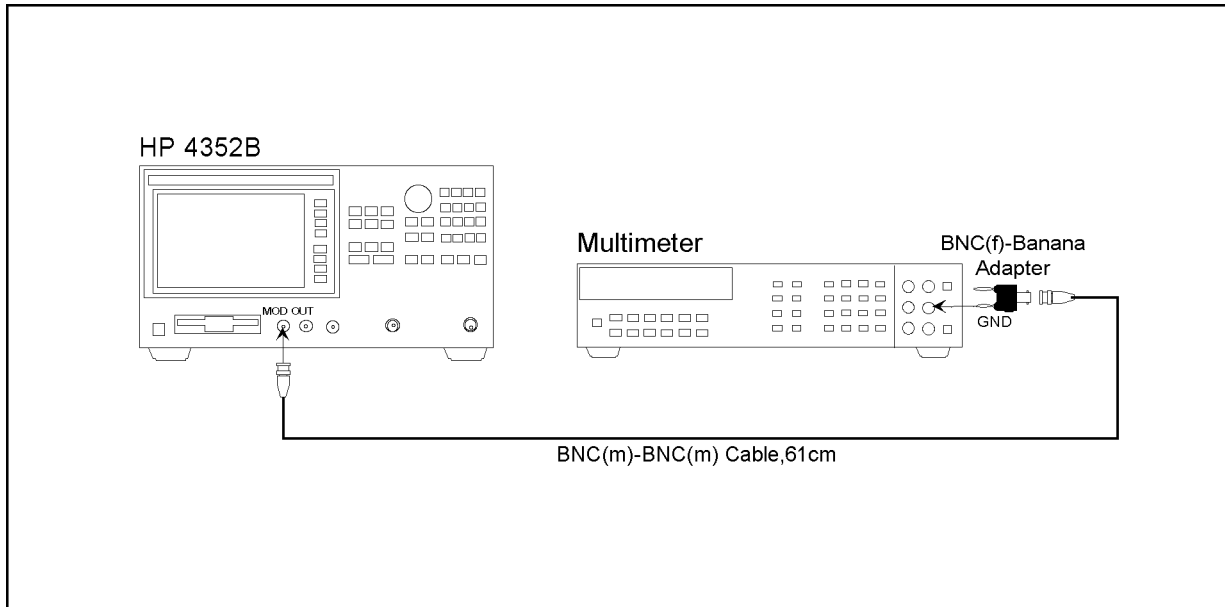

CDS02011

Figure 7-5. MOD OUT Signal Test Setup

2. Set the multimeter to the Synchronously Sub-sample AC voltage measurement mode (**ACV**, **SETACV SYNC**).
3. Press **[Preset]**, **[Mod]**, **MOD AMPLITUDE**, **[1]**, **[x1]** to set the modulation amplitude to $1 V_{rms}$. Press **MOD OUT off ON** to output the modulation signal.
4. Confirm that the multimeter reading value is $1 V_{rms} \pm 6 mV_{rms} @ 1 kHz$.
 - If it fails, go to the *Check REF OSC on A6*.
 - If it passes, there is no trouble found in the source group.

7. Check REF OSC on A6

Perform the following steps to confirm the REF OSC on A6 which derives MOD OUT signal by using the DC BUS function.

1. Press **[System]**, **SERVICE MENU**, **SERVICE MODES**, **BUS MEAS [OFF]**, **DC BUS [OFF]**, **[4]**, **[1]**, **[x1]**, **BUS MEAS on OFF** to select 41: [A6] REF LOOP VTUNE. Confirm that the marker reading value is $1.1 U \pm 0.5 U$.
 - If it fails, replace the A6 spectrum analyzer assembly.
 - If it passes, replace the A13 source assembly.

Receiver Group Troubleshooting

INTRODUCTION

Use these procedures only if you have read the *Overall Troubleshooting* chapter, and you believe the problem is in the receiver group.

These procedures are designed to let you identify the bad assembly within the receiver group in the shortest possible time. Whenever an assembly is replaced in this procedure, refer to *Post Repair Procedures* chapter in this manual.

The procedures isolate the faulty assembly by using the 4352B service functions. Therefore, before performing these procedures, verify the source group. See the *Overall Troubleshooting* chapter.

Figure 8-1 shows a simplified block diagram of the receiver group. The receiver group consists of the following assemblies:

- A5 Second PLL
- A6 Spectrum Analyzer
- A7 Power Divider
- A8 RF Attenuator
- A9 Peak Detector
- A10 First Mixer
- A11 Thermometer
- A part of A3/A13/A60

Note

Make sure all of the assemblies listed above are firmly seated before performing the procedures in this chapter.

Allow the analyzer to warm up for at least 30 minutes before you perform any procedure in this chapter.

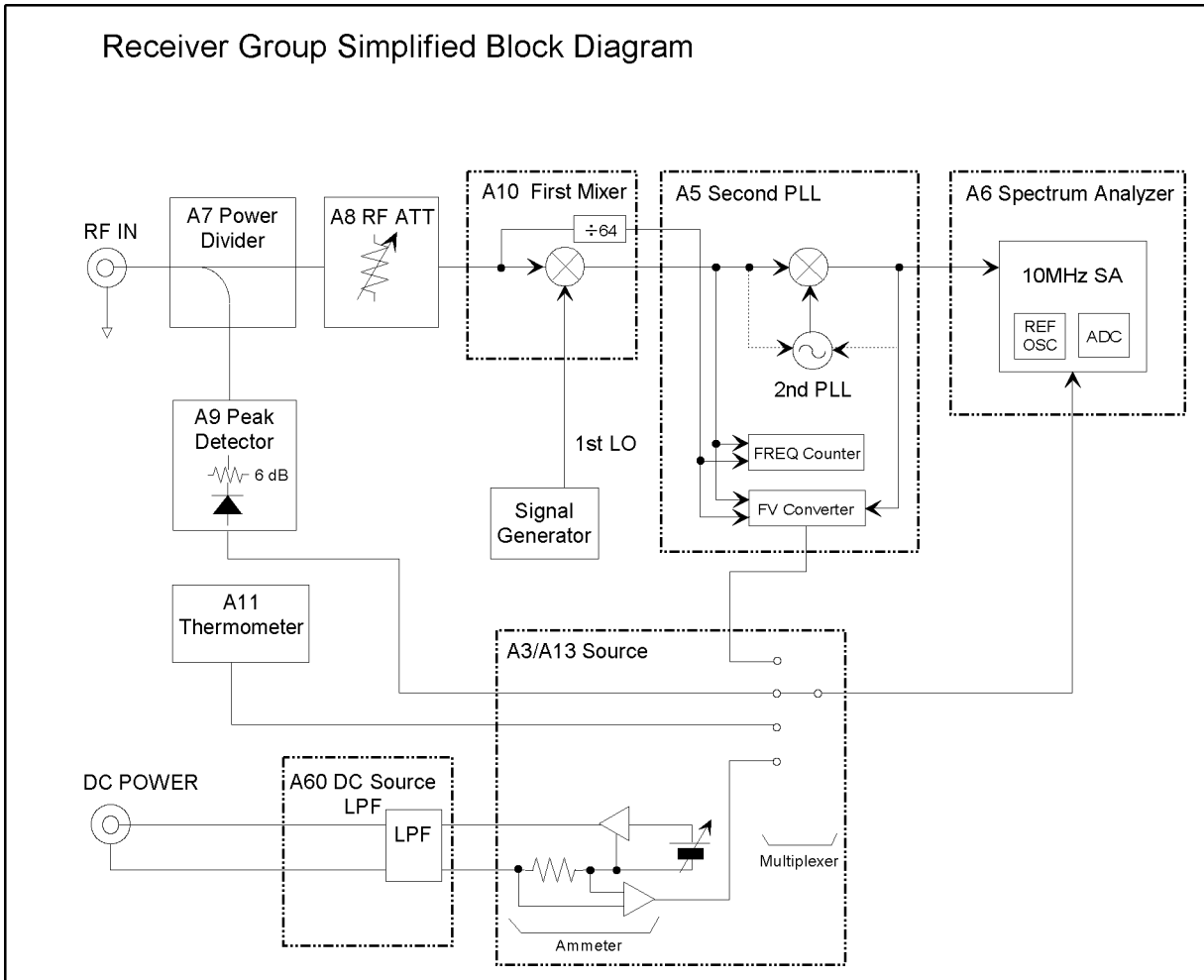

RECEIVER

Figure 8-1. Receiver Group Block Diagram

RECEIVER GROUP TROUBLESHOOTING SUMMARY

This overview summarizes the sequence of checks included in this chapter.

The receiver group troubleshooting flow is shown in Figure 8-2.

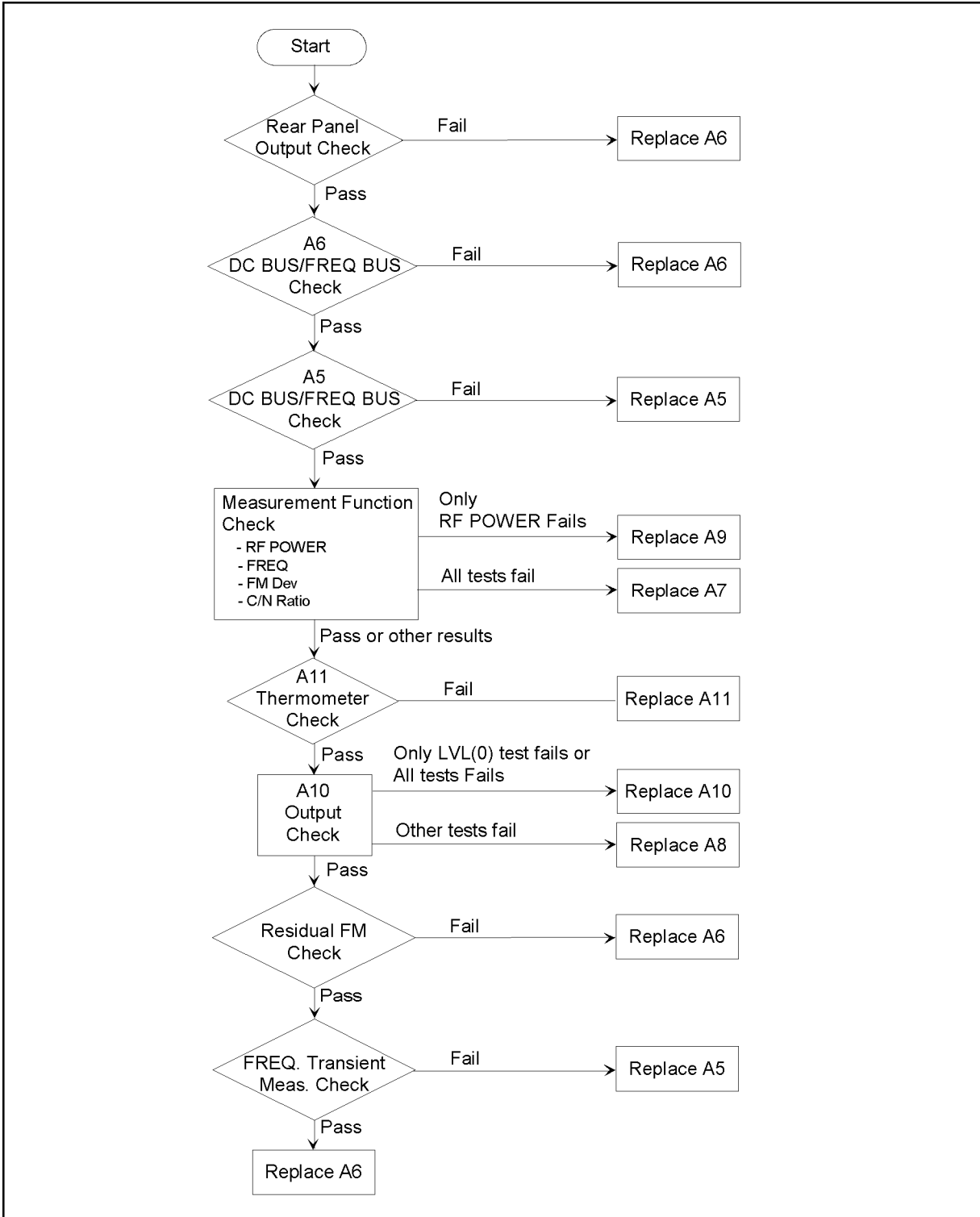

CAS08002

Figure 8-2. Receiver Group Troubleshooting Flow

START HERE

1. Check the Rear Panel Output signals (40MHz Output/INT_REF OUTPUT)

Perform the following steps to check the 40 MHz Output/INT_REF OUTPUT reference signals generated from the REF OSC on the A6 spectrum analyzer.

1. Connect the spectrum analyzer to the 40 MHz Output connector using BNC cable as shown in Figure 8-3.

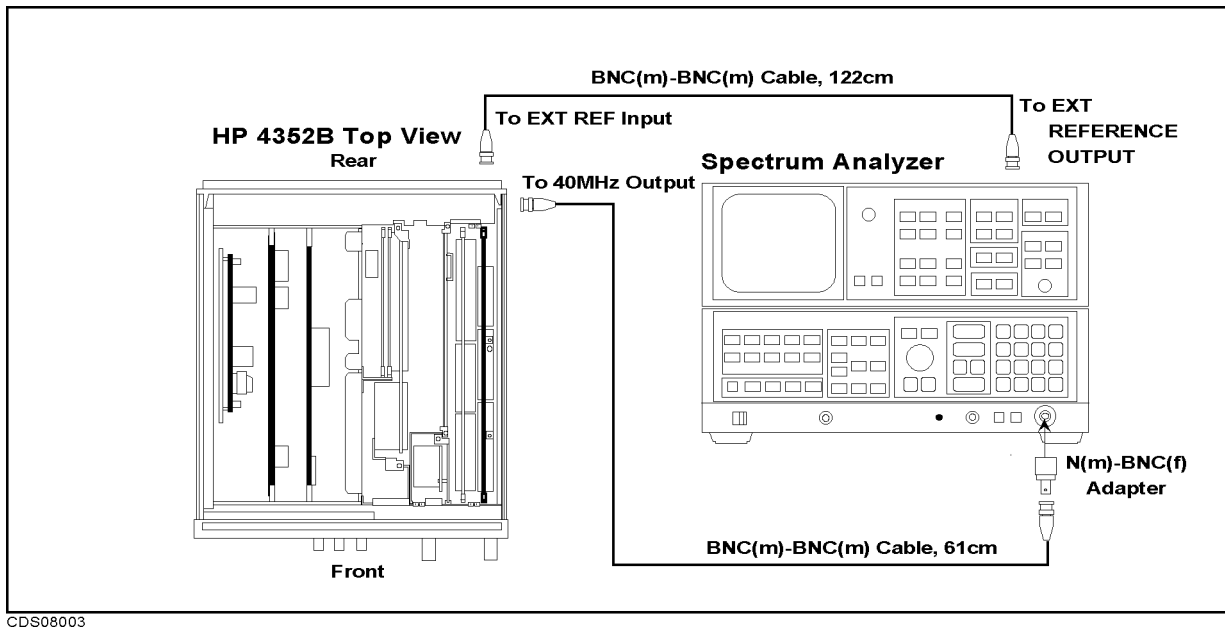

Figure 8-3. 40MHz Output/INT_REF OUTPUT Signals Test Setup

2. Confirm that the output spectrum is 40 MHz @ 11 dBm \pm 1dB.
 - If it fails, replace the A6 spectrum analyzer assembly.
 - If it passes, continue with the next step.
3. Change the connection from the 40 MHz Output connector to the INT REF Output connector.
4. Confirm that the output spectrum is 10 MHz @2.5 dBm \pm 1dB. If it fails, replace the A6 spectrum analyzer assembly.
 - If it fails, replace the A6 spectrum analyzer assembly.
 - If it passes, continue with the next step.

2. Check A6 Spectrum Analyzer

Perform the following steps to check the A6 spectrum analyzer by DC BUS/FREQ BUS functions.

1. Press (Preset), (System), SERVICE MENU, SERVICE MODES, BUS MEAS [OFF], DC BUS [OFF], (4), (0), (x1), BUS MEAS on OFF to set the DC BUS to 40 [A6] AD VREF.
2. Confirm that the marker reading value at the upper right corner is 0.2 U \pm 0.01 U.
 - If it fails, replace the A6 spectrum analyzer assembly.

- If it passes, continue with the next step.
3. Press **[4]**, **[1]**, **[x1]** to set the DC BUS to 41 [A6] REF LOOP VTUNE.
 4. Confirm that the marker reading value at the upper right corner is $1.1 \text{ U} \pm 0.05 \text{ U}$.
 - If it fails, replace the A6 spectrum analyzer assembly.
 - If it passes, continue with the next step.
 5. Press **[4]**, **[2]**, **[x1]** to set the DC BUS to 42 [A6] FIXED PLL VTUNE.
 6. Confirm that the marker reading value at the upper right corner is within the range of 0.4 U to 1.5 U.
 - If it fails, replace the A6 spectrum analyzer assembly.
 - If it passes, continue with the next step.
 7. Press **[4]**, **[5]**, **[x1]** to set the DC BUS to 45 [A6] GND.
 8. Confirm that the marker reading value at the upper right corner is within the range of -2.5 mU to +2.5 mU.
 - If it fails, replace the A6 spectrum analyzer assembly.
 - If it passes, continue with the next step.
 9. Press **[4]**, **[3]**, **[x1]** to set the DC BUS to 43 [A6] FN LOOP VTUNE.
 10. Press **RETURN**, **A6**, **PLL**, **AUTO CTRL ON off** to set AUTO CONTROL to OFF.
 11. Press **SPOT FREQ**, **[0]**, **[x1]** to set the spot frequency to 0 Hz.
 12. Confirm that the marker reading value at the upper right corner is $\pm 0.2 \text{ U}$.
 - If it fails, replace the A6 spectrum analyzer assembly.
 - If it passes, continue with the next step.
 13. Press **SPOT FREQ**, **[1]**, **[0]**, **[M/μ]** to set the spot frequency to 10 MHz.
 14. Confirm that the marker reading value at the upper right corner is within the range of 1.55 U to 1.93 U.
 - If it fails, replace the A6 spectrum analyzer assembly.
 - If it passes, continue with the next step.
 15. Remove the BNC-BNC Adapter from the 2ND IF Input/2ND IF Output connectors located on the rear panel.
 16. Connect the BNC Cable between the 2ND IF Input connector on the rear panel and the MOD OUT connector on the front panel as shown in Figure 8-4.

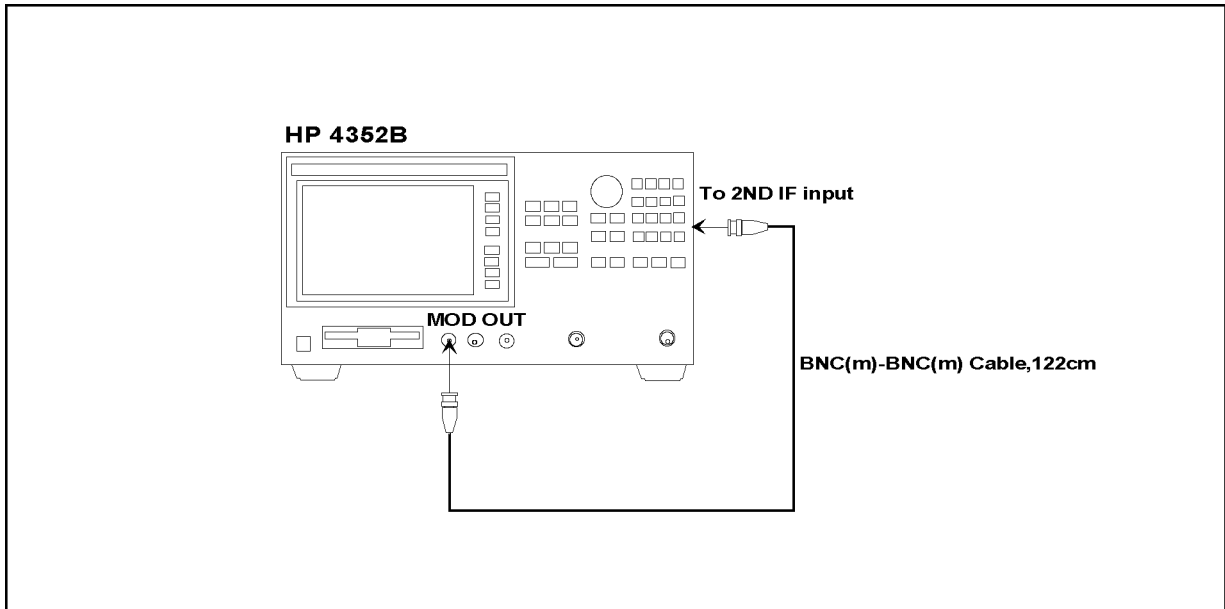

CDS08007

Figure 8-4. A6 Peak Detector Test Setup

17. Press **(Preset)**, **(System)**, **SERVICE MENU**, **SERVICE MODES**, **BUS MEAS [OFF]**, **DC BUS [OFF]**, **(4)**, **(4)**, **(x1)**, **BUS MEAS on OFF** to set the DC BUS to 44 [A6] PEAK DETECTOR.
18. Press **(Mod)**, **MOD AMPLITUDE**, **(4)**, **(4)**, **(k/m)** to set the MOD OUT amplitude to 44 mV_{rms}. Press **MOD OUT on OFF** to output the MOD OUT signal.
19. Press **(System)**, **SERVICE MENU**, **SERVICE MODES**, **A6**, **ATTEN/AMP**, **ATTEN: 0 dB**.
20. Confirm that the marker reading value at the upper right corner is within the range of 45 mU to 65 mU.
 - If it fails, replace the A6 spectrum analyzer assembly.
 - If it passes, continue with the next step.

Note



Remove the BNC cable from the 2nd IF Input connector, and reconnect the BNC(m)-BNC(m) Adapter between the 2nd IF Input and the 2nd IF Output connectors on the rear panel.

21. Press **(Preset)**, **(System)**, **SERVICE MENU**, **SERVICE MODES**, **BUS MEAS [OFF]**, **FREQ BUS [OFF]**, **(1)**, **(0)**, **(x1)**, **BUS MEAS on OFF** to set the FREQ BUS to 10 [A6] SAMPLE HOLD.
22. Confirm that the marker reading value is within the range of 79 mU to 81 mU.
 - If it fails, replace the A6 spectrum analyzer assembly.
 - If it passes, continue with the next step.
23. Press **(1)**, **(1)**, **(x1)** to set the FREQ BUS to 11 [A6] FM FREQ.
24. Confirm that the marker reading value is within the range of 0.99 mU to 1.01 mU.
 - If it fails, replace the A6 spectrum analyzer assembly.
 - If it passes, continue with the next step.

8-6 Receiver Group Troubleshooting

25. Press **[1]**, **[2]**, **[x1]** to set the FREQ BUS to 12 [A6] REF LOOP.
26. Confirm that the marker reading value is within the range of 39.6 mU to 40.4 mU.
 - If it fails, replace the A6 spectrum analyzer assembly.
 - If it passes, continue with the next step.
27. Press **[1]**, **[3]**, **[x1]** to set the FREQ BUS to 13 [A6] FIXED PLL.
28. Confirm that the marker reading value is within the range of 198 mU to 202 mU.
 - If it fails, replace the A6 spectrum analyzer assembly.
 - If it passes, continue with the next step.
29. Press **[1]**, **[4]**, **[x1]** to set the FREQ BUS to 14 [A6] FN LOOP.
30. Confirm that the marker reading value is within the range of 2.475 U to 2.525 U.
 - If it fails, replace the A6 spectrum analyzer assembly.
 - If it passes, continue with the next step.

3. Check A5 2nd PLL

Perform the following steps to check the A5 2nd PLL by DC BUS/FREQ BUS functions.

1. Press **[Preset]**, **[System]**, **SERVICE MENU**, **SERVICE MODES**, **BUS MEAS [OFF]**, **FREQ BUS [OFF]**, **[1]**, **[x1]**, **BUS MEAS on OFF** to set the FREQ BUS to 1 [A5] 2nd LOCAL.
2. Press **RETURN**, **A5**, **2nd PLL**, **PLL MODE: SINGLE**, **PLL BW: WIDE**, **PLL REF: FIXed**, **MORE**. Confirm that the PLL OFST setting is OFF (**PLL OFST on OFF**).
3. Press **2nd PLL DIVIDER**, **[3]**, **[8]**, **[x1]**.
4. Confirm that the marker reading value at the upper right corner is 1.1875 U ± 0.0001 U.
 - If it fails, replace the A5 2nd PLL assembly.
 - If it passes, continue with the next step.
5. Press **2nd PLL DIVIDER**, **[6]**, **[2]**, **[x1]**.
6. Confirm that the marker reading value at the upper right corner is 1.9375 U ± 0.0001 U.
 - If it fails, replace the A5 2nd PLL assembly.
 - If it passes, continue with the next step.
7. Press **PLL OFST on OFF** to set PLL OFST to ON.
8. Press **2nd PLL DIVIDER**, **[4]**, **[8]**, **[x1]**.
9. Confirm that the marker reading value at the upper right corner is 1.5050 U ± 0.0001 U.
 - If it fails, replace the A5 2nd PLL assembly.
 - If it passes, continue with the next step.
10. Press **[Preset]**, **[System]**, **SERVICE MENU**, **SERVICE MODES**, **BUS MEAS [OFF]**, **FREQ BUS [OFF]**, **[2]**, **[x1]**, **BUS MEAS on OFF** to set the FREQ BUS to 2 [A5] FREQ COUNTER.
11. Press **RETURN**, **A5**, **FREQ COUNTER**. Confirm that the frequency counter input (FREQ CNTR INPUT:) is FV CAL.
12. Press **RETURN**, **RETURN**, **A6**, **FV CALOUT on OFF** to set FV CALOUT to ON.

13. Press **PLL**, **AUTO CTRL ON off** to set AUTO CTRL to OFF.
14. Press **SPOT FREQ**, **2**, **0**, **5**, **8**, **(M/μ)** to set the spot frequency to 2.58 MHz.
15. Confirm that the marker reading value at the upper right corner is $1.5000\text{ U} \pm 0.0001\text{ U}$.
 - If it fails, replace the A5 2nd PLL assembly.
 - If it passes, continue with the next step.
16. Press **(Preset)**, **(System)**, **SERVICE MENU**, **SERVICE MODES**, **BUS [OFF]**, **FREQ BUS [OFF]**, **3**, **(x1)**, **BUS MEAS on OFF** to set the FREQ BUS to 3 [A5] FV CONVERTER.
17. Press **RETURN**, **A5**, **FREQ CONVERTER**. Confirm that the frequency counter input (FREQ CNVTR INPUT:) is FV CAL, and the FV DIV MOD is set to OFF.
18. Press **FV DIVIDER**, **1**, **2**, **(x1)** to set the FV DIVIDER to 12.
19. Press **FV RANGE**, **FV RANGE: 1MHz** to set the FV RANGE to 1MHz.
20. Press **RETURN**, **RETURN**, **RETURN**, **A6**, **FV CALOUT on OFF** to set the FV CALOUT to ON.
21. Press **PLL**, **AUTO CNTRL ON off** to set the AUTO CONTROL to OFF.
22. Press **SPOT FREQ**, **2**, **0**, **5**, **8**, **(M/μ)** to set the spot frequency to 2.58 MHz.
23. Confirm that the marker reading value at the upper right corner is $2.000\text{ U} \pm 0.0001\text{ U}$.
 - If it fails, replace the A5 2nd PLL assembly.
 - If it passes, continue with the next step.
24. Press **(Preset)**, **(System)**, **SERVICE MENU**, **SERVICE MODES**, **BUS MEAS [OFF]**, **DC BUS [OFF]**, **3**, **0**, **(x1)**, **BUS MEAS on OFF** to set the DC BUS to 30 [A5] VCO VTUNE.
25. Press **RETURN**, **A5**, **2nd PLL**. Set the control settings as follows:
 - PLL MODE is set to SINGLE.
 - PLL BW is set to WIDE.
 - PLL REF is set to FIXed.
26. Press **MORE**. Confirm that the PLL OFST is set to OFF.
27. Press **2nd PLL DIVIDER**, **3**, **8**, **(x1)** to set the 2nd PLL DIVIDER to 38.
28. Confirm that the marker reading value at the upper right corner is $-1.5\text{ U} \pm 0.3\text{ U}$.
 - If it fails, replace the A5 2nd PLL assembly.
 - If it passes, continue with the next step.
29. Press **6**, **2**, **(x1)** to set the 2nd PLL DIVIDER to 62.
30. Confirm that the marker reading value at the upper right corner is $+1.7\text{ U} \pm 0.3\text{ U}$.
 - If it fails, replace the A5 2nd PLL assembly.
 - If it passes, continue with the next step.

4. Check Measurement Functions

Perform the following steps to check the receiver group's measurement functions by using the 40MHz Output/INT_REF OUTPUT signals, and especially to confirm that the A7 power divider/A9 peak detector is working properly.

Note



This is the same procedure as described in *OPERATOR'S CHECK*. If you have already done the OPERATOR'S CHECK, go to the step 6 of this procedure.

1. Connect the two BNC Cables as shown in Figure 8-5.

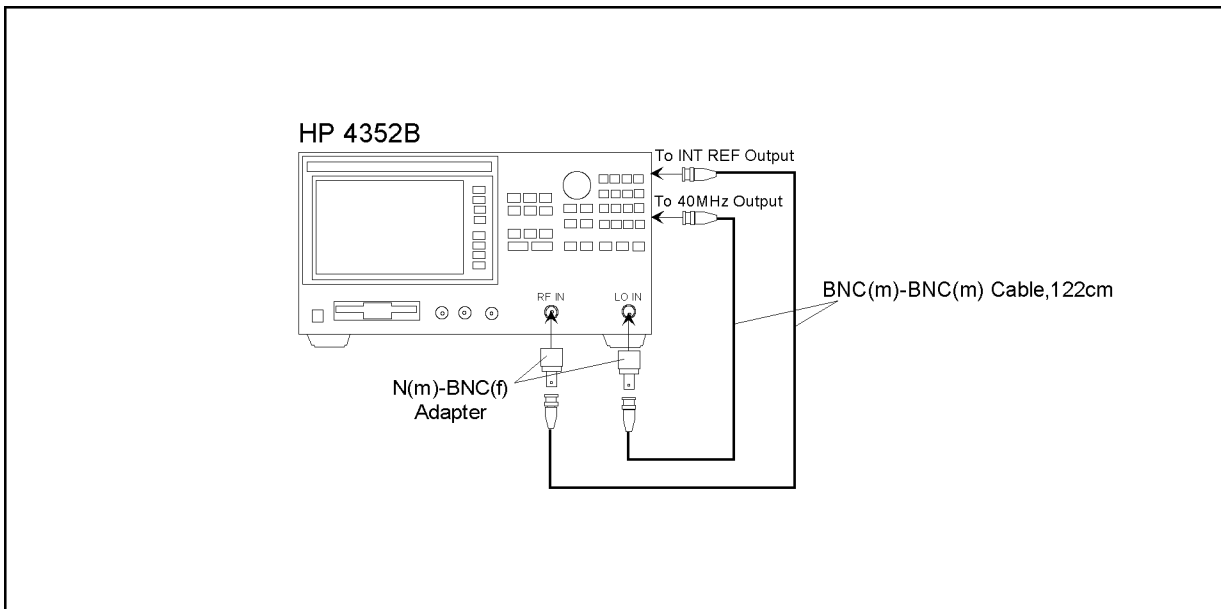

CDS02004

Figure 8-5. Measurement Functions Test Setup

2. Check RF POWER measurement.
 - a. Press **Preset**, **Meas**, **INST TYPE**, **INST TYPE: VCO TESTER**, **MEAS: RF POWER**.
 - b. Confirm that the reading value is within $2.5 \text{ dBm} \pm 1 \text{ dB}$. Record the result (pass or fail) as RESULT(RF).
3. Check FREQUENCY measurement.
 - a. Press **Meas**, **FREQUENCY**, **Sense Range**, **FREQ RES: 64 kHz**.
 - b. Confirm that the reading value is within $10 \text{ MHz} \pm 100 \text{ kHz}$. Record the result (pass or fail) as RESULT(FREQ).
4. Check FM Deviation measurement.
 - a. Press **Meas**, **FM DEVIATION**, **Sense Range**, **FM DEV RANGE**, **FM DEV RNG: 2kHz**, **Bw/Avg**, **FM DETECTION**, **HP FILTER: 300 Hz**, **LP FILTER: 3 kHz**.
 - b. Confirm that the reading value is equal to, or less than 3 Hzrms. Record the result (pass or fail) as RESULT(FM).

5. Check C/N ratio measurement.
 - a. Press **[Meas]**, **CARRIER/NOISE**, **[Bw/Avg]**, **OFFSET FREQ**, **[1]**, **[k/m]**.
 - b. Confirm that the reading value is equal to, or greater than 100 dBc. Record the result (pass or fail) as RESULT(CN(1k)).
 - c. Press **OFFSET FREQ**, **[1]**, **[0]**, **[k/m]**.
 - d. Confirm that the reading value is equal to, or greater than 130 dBc. Record the result (pass or fail) as RESULT(CN(10k)).
 - e. Press **OFFSET FREQ**, **[1]**, **[0]**, **[0]**, **[k/m]**.
 - f. Confirm that the reading value is equal to, or greater than 140 dBc. Record the result (pass or fail) as RESULT(CN(100k)).
6. Decide which assembly is faulty according to the following guideline.
 - If all results (RESULT(RF)) through RESULT(CN(100k)) are “FAIL”, replace the A7 power divider assembly.
 - If only RESULT(RF) is “FAIL”, replace the A9 peak detector assembly.
 - Otherwise, continue with the next step.

5. Check A11 Thermometer

Perform the following steps to check that the A11 thermometer by using the DC BUS function.

1. Press **[Preset]**, **[System]**, **SERVICE MENU**, **SERVICE MODES**, **BUS MEAS [OFF]**, **DC BUS [OFF]**, **[5]**, **[1]**, **[x1]**, **BUS MEAS [off ON]**, **RETURN**, **A3**, **OUTPUT SELECT**, **TEMP**.
2. Multiply the marker reading value by 100. Confirm that the multiplied value is within the range of -5 to +60.
 - If it fails, replace A11 thermometer.
 - If it passes, continue with the next step.

6. Check the outputs from A10 1st Mixer

Perform the following steps to measure the output signals from the A10 1st Mixer by using the spectrum analyzer, and to confirm that the A8 RF attenuator/A10 1st Mixer is working properly.

1. Turn the 4352B power off.
2. Connect two BNC Cables with two N(m)-BNC(f) adapters as shown in Figure 8-6.

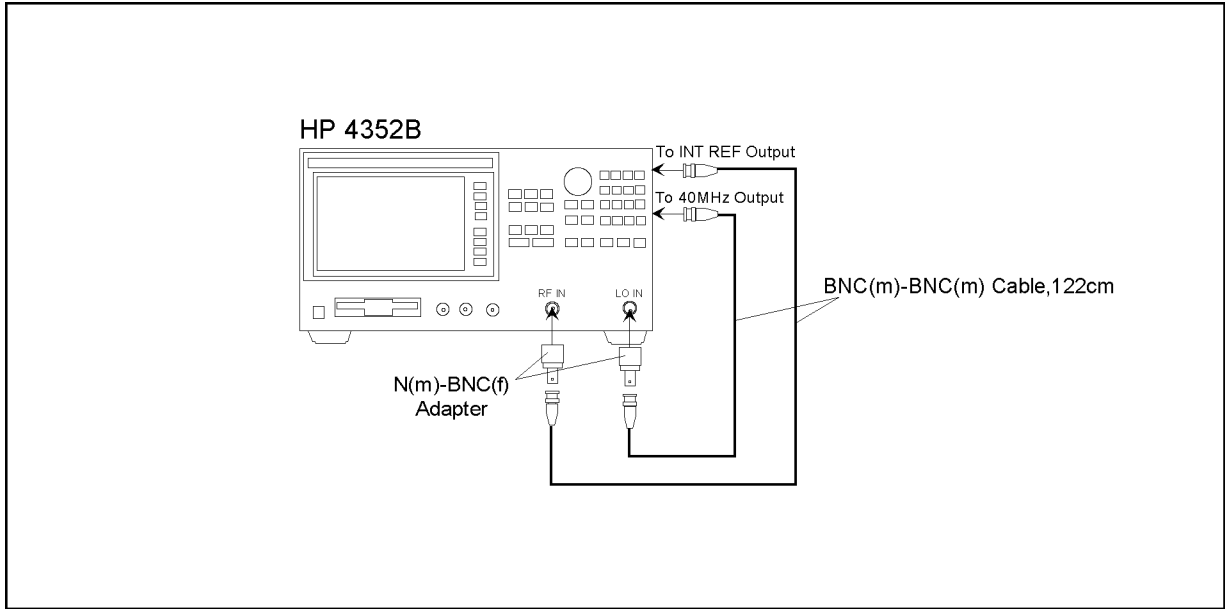

CDS02004

Figure 8-6. A10 Output Test Setup 1

3. Remove the top cover, and the shield plate.
4. Remove the “J” labeled cable connected to the A5. Connect the BNC cable with the SMB(m)-BNC(f) adapter between the “J” cable and the spectrum analyzer as shown in Figure 8-7.

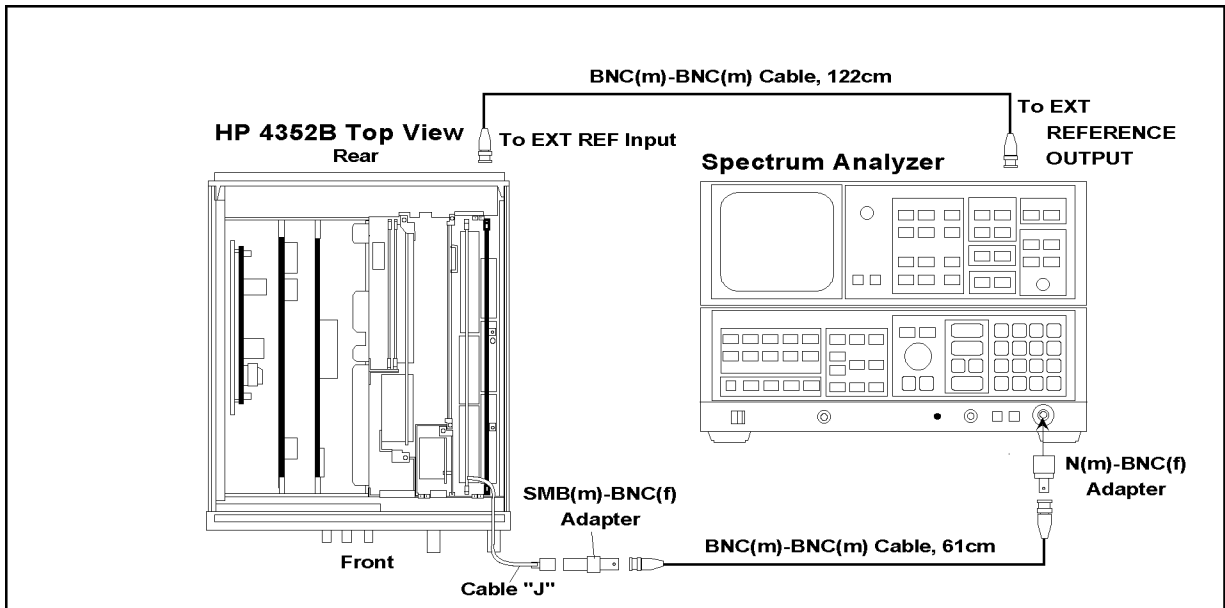

CDS08006

Figure 8-7. A10 Output Test Setup 2

5. Set the spectrum analyzer as follows:
 CENTER 30 MHz

SPAN 100 kHz
 RBW 1 kHz
 REF LEVEL 0 dBm

6. Turn the 4352B power on.
7. Set the RF attenuator according to the following table by pressing **(Sense Range)**, **RF ATTEN**, and entry keys, and record each 30 MHz peak value of each RF attenuator setting of the spectrum analyzer as LEVEL(0) through LEVEL(25).

RF ATTEN	Record peak value @ 30MHz as:
0 dB	LEVEL(0)
5 dB	LEVEL(5)
10 dB	LEVEL(10)
15 dB	LEVEL(15)
20 dB	LEVEL(20)
25 dB	LEVEL(25)

8. Calculate the following formula, and confirm that each calculated value is within the range of the limits.

Formula	Limits
LEVEL(0)	$-12 \text{ dBm} \leq \text{LEVEL}(0) \leq -2 \text{ dBm}$
$\text{LEVEL}(5) - \text{LEVEL}(0) + 5 = A$	$-1.5 \text{ dB} \leq A \leq 1.5 \text{ dB}$
$\text{LEVEL}(10) - \text{LEVEL}(0) + 10 = B$	$-1.5 \text{ dB} \leq B \leq 1.5 \text{ dB}$
$\text{LEVEL}(15) - \text{LEVEL}(0) + 15 = C$	$-1.5 \text{ dB} \leq C \leq 1.5 \text{ dB}$
$\text{LEVEL}(20) - \text{LEVEL}(0) + 20 = D$	$-1.5 \text{ dB} \leq D \leq 1.5 \text{ dB}$
$\text{LEVEL}(25) - \text{LEVEL}(0) + 25 = E$	$-1.5 \text{ dB} \leq E \leq 1.5 \text{ dB}$

9. Turn the 4352B power off.
10. Disconnect the cable from the connector “J”, and reconnect the cable “J”.
11. Decide which assembly is faulty according to the following guideline.
 - If all tests pass, continue with the next step.
 - If all fail, replace the A10 1st Mixer assembly.
 - If only LEVEL(0) fails, replace the A10 1st Mixer assembly.
 - Otherwise, replace the A8 RF attenuator assembly.

7. Check the Residual FM

Perform the following steps to checks that the residual FM is within the limit.

1. Connect the test equipment as shown in Figure 8-8.

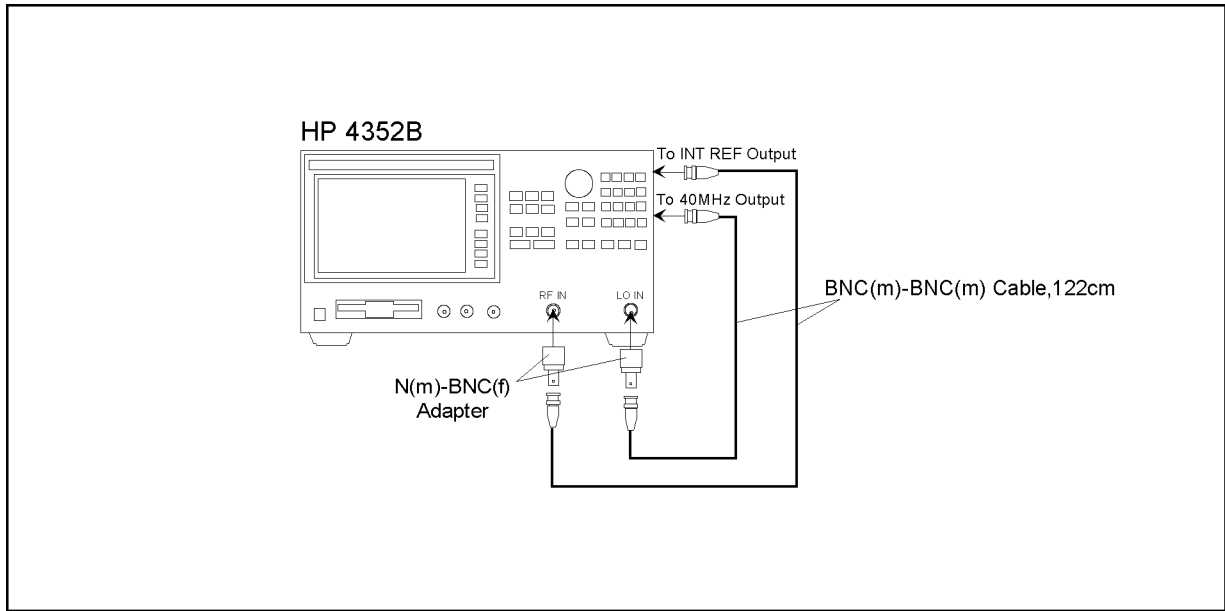

CDS02004

Figure 8-8. FM Deviation Residual FM Test Setup

2. Press **(Preset)** to initialize the 4352B.
3. Press **(Meas)**, **INST TYPE**, **INST TYPE: VCO TESTER**, **FM DEVIATION** to set the measurement item to FM Deviation in Tester mode.
4. Press **(Sense Range)**, **FM DEV RANGE**, **2kHz** to set the FM Deviation range to 2 kHz.
5. Press **(Bw/Avg)**, **FM DETECTION**, **300 Hz**, **LP FILTER: 3kHz** to set the filter bandwidth to the range between 300 Hz and 3 kHz.
6. Confirm that the 4352B reading is within the range of 0 Hz_{rms} to 3 Hz_{rms}.
 - If it fails, replace the A6 spectrum analyzer assembly.
 - If it passes, continue with the next step.

8. Check the Frequency Transient measurement

Perform the following steps to check the functions for RF Transient measurement, and to isolate which is probably faulty: the A5 2nd PLL assembly or the A6 spectrum analyzer assembly.

1. Connect two BNC Cables with two N(m)-BNC(f) adapters as shown in Figure 8-9.

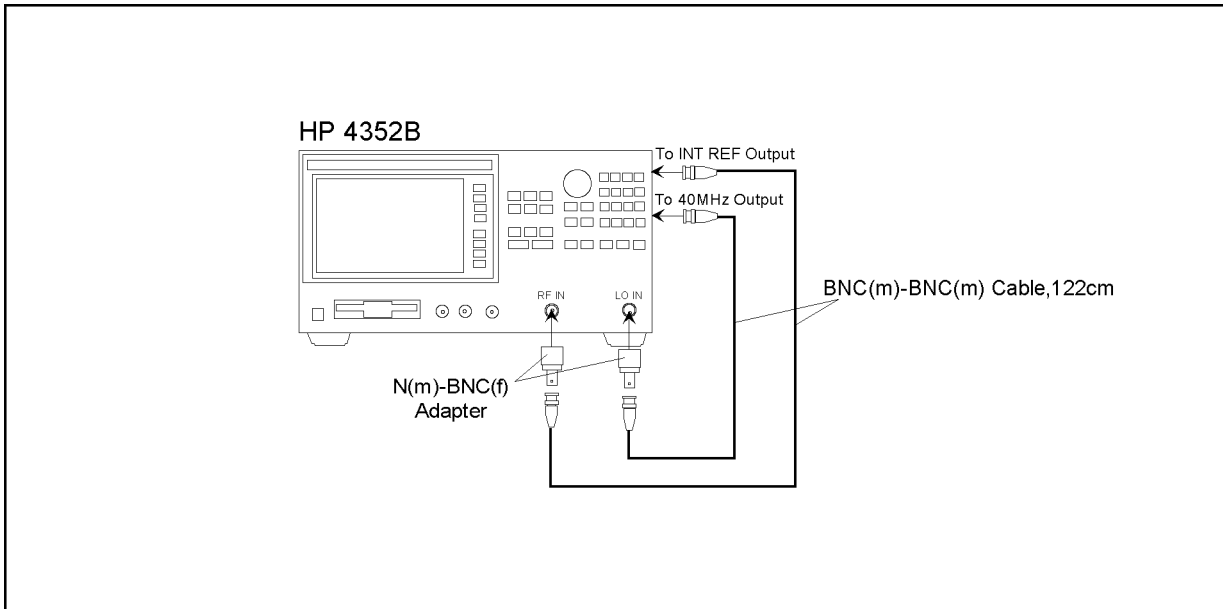

CDS02004

Figure 8-9. Frequency Transient Measurement Test Setup

2. Press **Preset**, **Meas**, **INST TYPE**, **VCO ANALY**, **RF TRANSIENT** to set the measurement function to FREQUENCY TRANSIENT.
3. Press **Sense Range**, **RF TRANS MAX FREQ**, **3**, **0**, **M/μ**, **RF TRANS MIN FREQ**, **1**, **0**, **M/μ**, **Menu**, **MARKER**.
4. Confirm that the reading value is 10 MHz ± 30 kHz.
 - If it fails, replace the A5 2nd PLL assembly.
 - If it passes, replace the A6 spectrum analyzer assembly.

Service Key Menus

INTRODUCTION

The service key menus are used to test, verify, adjust, and troubleshoot the analyzer. They are also used to install and update the firmware in the analyzer.

The service key menus consist of several menus that are accessed through the service menu and the Bootloader menu as shown in Figure 9-1. The service menu is displayed by pressing **System**, **SERVICE MENU**. The Bootloader menu is displayed by turning the analyzer power on while pressing **DC Control** and **Preset**.

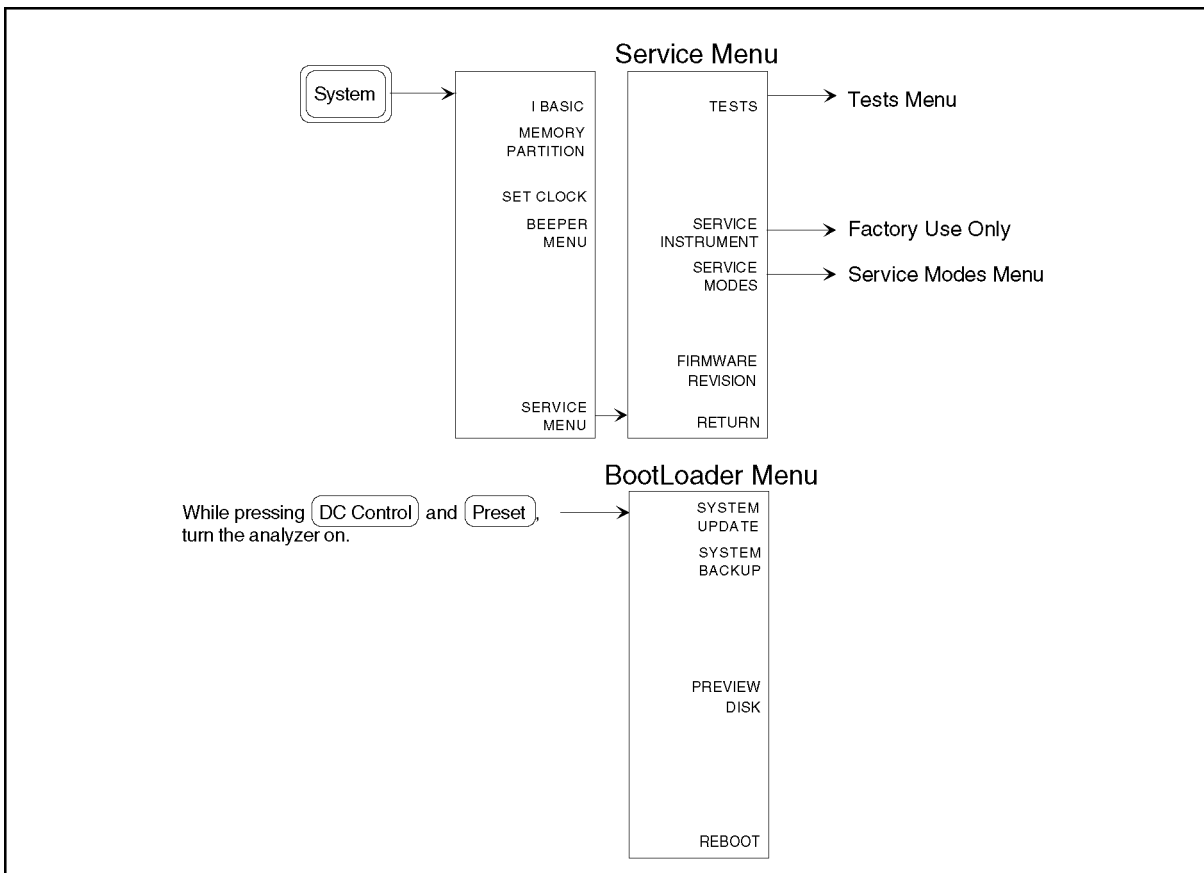

Figure 9-1. Service Key Menus

The service key menus allow you to perform the following functions:

- Select and execute a built-in diagnostic test. The analyzer has 22 built-in diagnostic tests. For detailed information, see the *Tests Menu* in this chapter.

- Control and monitor various circuits for troubleshooting. For detailed information, see the *Service Modes Menu* in this chapter.
- Display the firmware revision. See the *Service Menu* .
- Install and update the firmware in the analyzer. For detailed information, see the *Bootloader Menu* in this chapter.

When applicable, the GPIB mnemonic is written in parentheses following the softkey using the following symbol conventions:

- { } A necessary appendage
- <numeric> A necessary numerical appendage
- | A delimiter for applicable appendages. For example, {OFF|ON|0|1|} means OFF, ON, 0, or 1.

For more information about the GPIB commands, see the *4352B GPIB Command Reference*.

SERVICE MENU

Figure 9-2 shows the service menu. This menu is used to display the tests menu, the service modes menu, and the firmware revision information. To display the service menu, press `(System)`, `SERVICE MENU`. Each softkey in the service menu is described below.

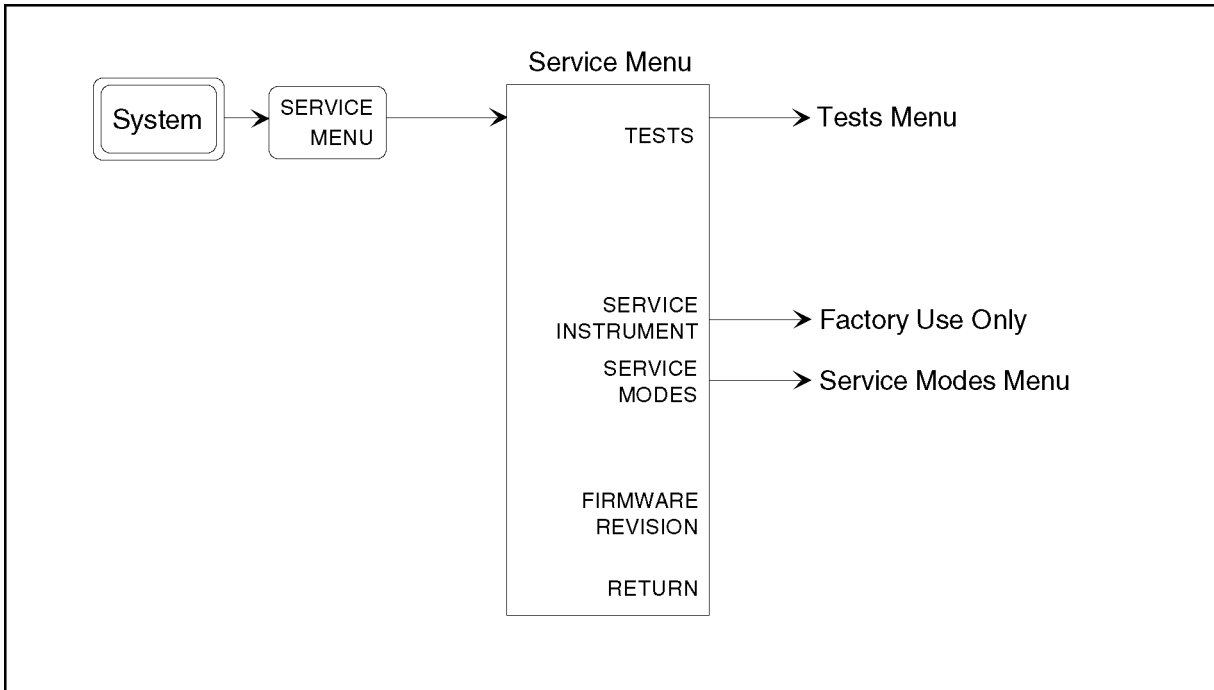

C5S10002

Figure 9-2. Service Menu

TESTS

Displays the tests menu. For more information about the tests menu, see the *Tests Menu* later in this chapter.

SERVICE INSTRUMENT

Only for use by factory personnel.

SERVICE MODES (:DIAG:SERV:MODE {OFF|ON|0|1})

Activates the service modes and displays the service modes menu. For more information about the service modes menu, see the *Service Modes Menu* later in this chapter.

FIRMWARE REVISION (:DIAG:FREV?)

Displays the current firmware revision information. The number and implementation date appear in the active entry area of the display as shown below.

```
4352B REVN.NN MON DD YEAR HH:MM:SS
```

where	N.NN:	Revision Number
	MON DD YEAR	Implementation Date (Month Day Year)
	HH:MM:SS	Implementation Time (Hour:Minute:Second)

TESTS MENU

Figure 9-3 shows the tests menu. The tests menu is used to select and execute one of the 22 built-in diagnostic tests. More information about the diagnostic tests is provided in the *Diagnostic Tests* later in this section. To display the tests menu, press **System**, **SERVICE MENU**, and **TESTS**.

When entering the tests menu, internal test 0: ALL INT is selected as the default test. The test number, name, and status abbreviation is displayed in the active entry area of the display. For the test status, see Figure 9-4.

The diagnostic tests are numbered from 0 to 35. To select a test, enter the desired test number using the numeric keypad, **↑**, **↓**, RPG knob or GPIB command (:DIAG:TEST<numeric>).

Each softkey in the tests menu is described below.

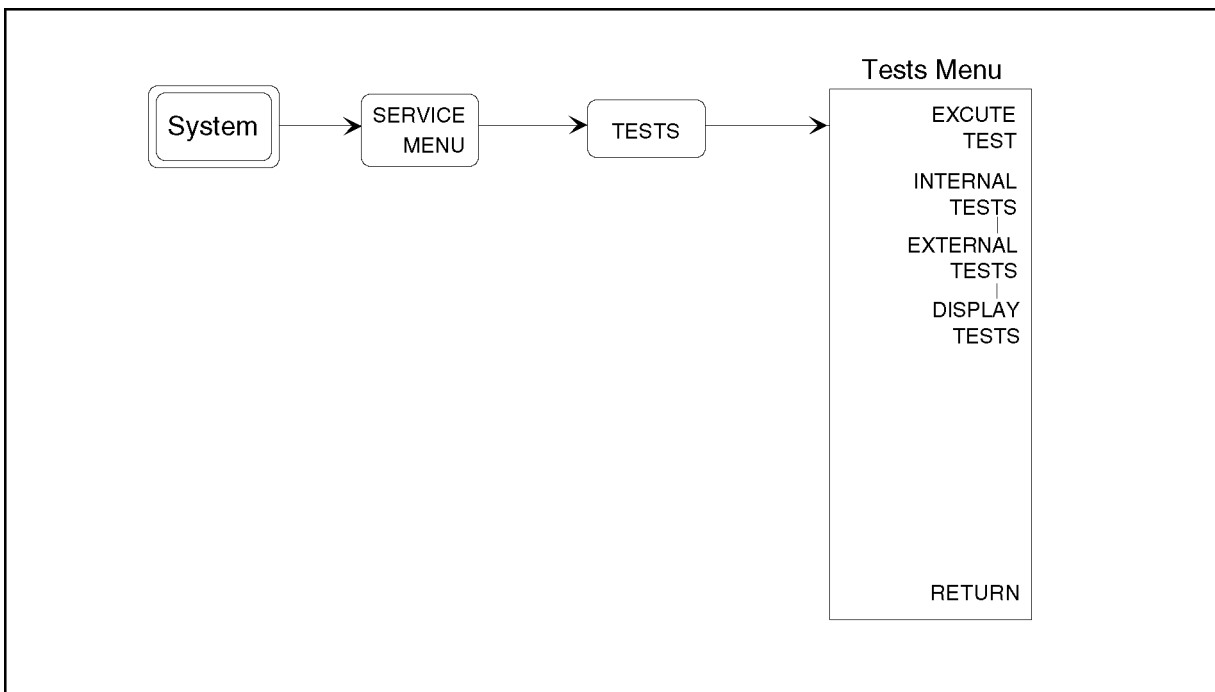

C5S10003

Figure 9-3. Tests Menu

EXECUTE TEST (:DIAG:TEST:EXEC)

Runs the selected test. When the executed test requires user interaction, **CONT** (:DIAG:TEST:CONT) and the instruction appear on the display. Follow the displayed instruction and press **CONT** to continue the test.

INTERNAL TESTS (:DIAG:TEST 0)

Selects the first internal test 0: ALL INT.

EXTERNAL TESTS (:DIAG:TEST 11)

Selects the first external test 11: FRONT PANEL DIAG.

DISPLAY TESTS (:DIAG:TEST 21)

Selects the first display test 21: TEST PATTERN 1.

Note



After executing a test by pressing **EXECUTE TEST**, an annotation (Svc) is displayed to indicate which tests are executing and that the analyzer settings are changed to the test settings. To return the analyzer to normal operation, cycle the analyzer power (off then on), or press **(Preset)**.

Note



While any test is being executed, do not change any analyzer setting using the front-panel keys, the GPIB, or the I-BASIC program. If the setting is changed during test execution, the test result and the analyzer operation will be unreliable.

Test Status

When selecting a test, the test status abbreviation is displayed as shown in Figure 9-4.

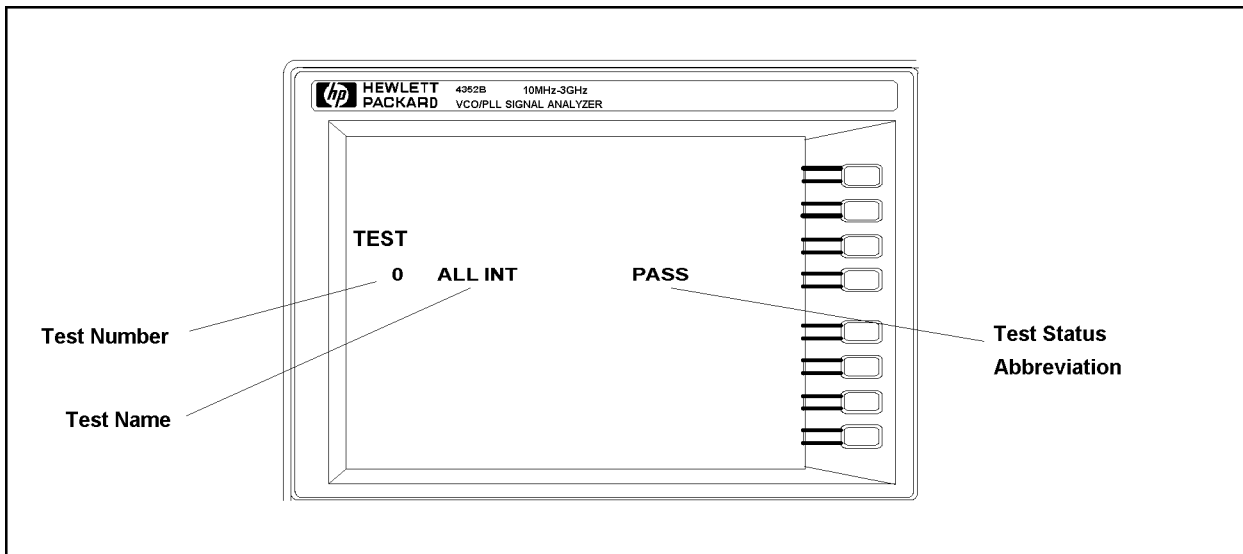

CDS10005

Figure 9-4. Test Status on the Display

To see the test status of the desired test, enter the desired test number using the numeric keypad, **(↑)**, **(↓)**, or RPG knob. Also, the three GPIB commands listed below are available to get the test status using GPIB.

`:DIAG:TEST:RES? <numeric>` returns the test status. The *<numeric>* specifies the test number and is an integer from 0 to 35.

The power on self-test consists of A1 CPU DRAM write/read test, Dual Port SRAM write/read test, and the internal test 4: [A2] POST REGULATOR. If the test fails, a “*POWER ON TEST FAILED*” message is displayed at the end of the power on sequence.

Internal Tests	These tests are completely internally and are self-evaluating. They do not require external connections or user interaction. The analyzer has 4 internal tests.
External Tests	These are additional self-evaluating tests. However, these tests require some user interaction (such as key entries). The analyzer has 3 external tests.
Display Tests	These tests are used to check for proper operation of the display circuits. The analyzer has 5 display tests.

Test Descriptions

This section describes all 12 diagnostic tests.

INTERNAL TESTS

This group of tests run without external connections or operator interaction. All return a “PASS” or “FAIL” indication on the display. Except as noted, all are run during the power on self-test and when **(Preset)** pressed.

0: ALL INT

Runs only when selected. It consists of internal tests (1, 4). If any of these tests fail, this test displays the “FAIL” status indication. Use the RPG knob to scroll through the tests to see which test failed. If all pass, the test displays the “PASS” status indication. Each test in the subset retains its own test status.

1: A1 CPU

Verifies the following circuit blocks on the A1 CPU:

- Flash Memory Check Sum
- Digital Signal Processor (DSP)
- System Timer
- Real Time Clock
- Front Key Controller
- Flexible Disk Drive Controller
- GPIB Controller
- mini-DIN Chip
- EEPROM

2: A1 VOLATILE MEMORY

Runs only when selected. It verifies the A1 volatile memories:

- CPU internal SRAM
- DSP SRAM
- Dual Port SRAM
- Backup SRAM

At the end of the test, the analyzer is set to the power-on default state because the data in the tested memories has been destroyed. During this test, a test pattern is written into the memories and then the pattern is read back and checked.

If the test fails, the test displays an error message for a few seconds and then sets the analyzer to the default state. The error message indicates the faulty memory location.

3: A51 GSP

Runs only when selected. It verifies the following circuit blocks on the A51 GSP:

- GSP Chip
- DRAM
- VRAM

At the end of this test, the analyzer is set to the power-on default state because the data in the tested memories has been destroyed. During this test, a test pattern is written into the memories and then the pattern is read back and checked.

If the test fails, the analyzer beeps. It then sets the analyzer to the default state. If the GSP chip is faulty, a beep sounds. If the DRAM is faulty, two beeps sound. If the VRAM is faulty, three beeps sound.

4: A2 POST REGULATOR

Verifies all A2 post regulator output voltages:

- +5 V(AUX), +15 V(AUX)
- 15 V, -12.6 V, -5 V, +5 V, +5.3 V, +8.5 V, +15 V,
- +22 V, FAN POWER, GND

This test measures the A2 output voltages at DC bus nodes 1 through 12. It checks that each measured value is within limits.

5 through 10: N/A

These numbers are not assigned for tests.

EXTERNAL TESTS

This group of tests requires either external equipment and connections or operator interaction to run. These tests are used in the *Troubleshooting* chapter.

11: FRONT PANEL DIAG.

Checks the RPG and all front panel keys on the A30 keyboard. The abbreviated name is displayed by pressing one of the keys or by rotating the RPG.

12: DSK DR FAULT ISOL'N

Checks the FDD (Flexible Disk Drive). A formatted, blank disk is required. When this test is started, a bit pattern is written to the flexible disk. The pattern is then read back and checked. This write pattern check is repeated from the low to high addresses.

Note After this test is performed, the data stored on the floppy disk is lost.



13: 24 BIT I/O PORT

Checks the 24 bit I/O Port function on the rear panel. This test requires I/O Port Test Kit (PN 87510-65002). For a more detailed procedure, refer to the *Digital Control Troubleshooting*.

14 through 20: N/A

Does not assign the tests.

DISPLAY TESTS

These tests are test patterns that are used to inspect the LCD display. Test patterns are executed by entering the test number (21 through 25), then pressing **EXECUTE TEST**, **CONTINUE**. The test pattern is displayed and the softkey labels are blanked. To exit the test pattern and return to the softkey labels, press softkey 8 (on the bottom). The following is a description of the test patterns.

Note



Do NOT press any keys except softkey 8 (on the bottom) while the test pattern is being executed. If you do, you CANNOT quit the test pattern (that is, you can quit the test pattern only when the analyzer is turned OFF).

21: TEST PATTERN 1

All Black. This pattern is used to verify the color purity of the LCD Display.

22: TEST PATTERN 2

All White. This pattern is used to verify the light output and to check the color purity of the LCD display.

23: TEST PATTERN 3

All Red. This pattern has the same use as TEST PATTERN 2.

24: TEST PATTERN 4

All Green. This pattern has the same use as TEST PATTERN 2.

25: TEST PATTERN 5

All Blue. This pattern has the same use as TEST PATTERN 2.

SERVICE MODES MENU

Figure 9-6 shows the service modes menu. The service modes menu leads to one of the menus used to control the analyzer service modes. For the analyzer's service modes, see the *Service Modes* . To display the service modes menu, press **System**, **SERVICE MENU**, and **SERVICE MODES** . Each softkey in the service modes menu is described below.

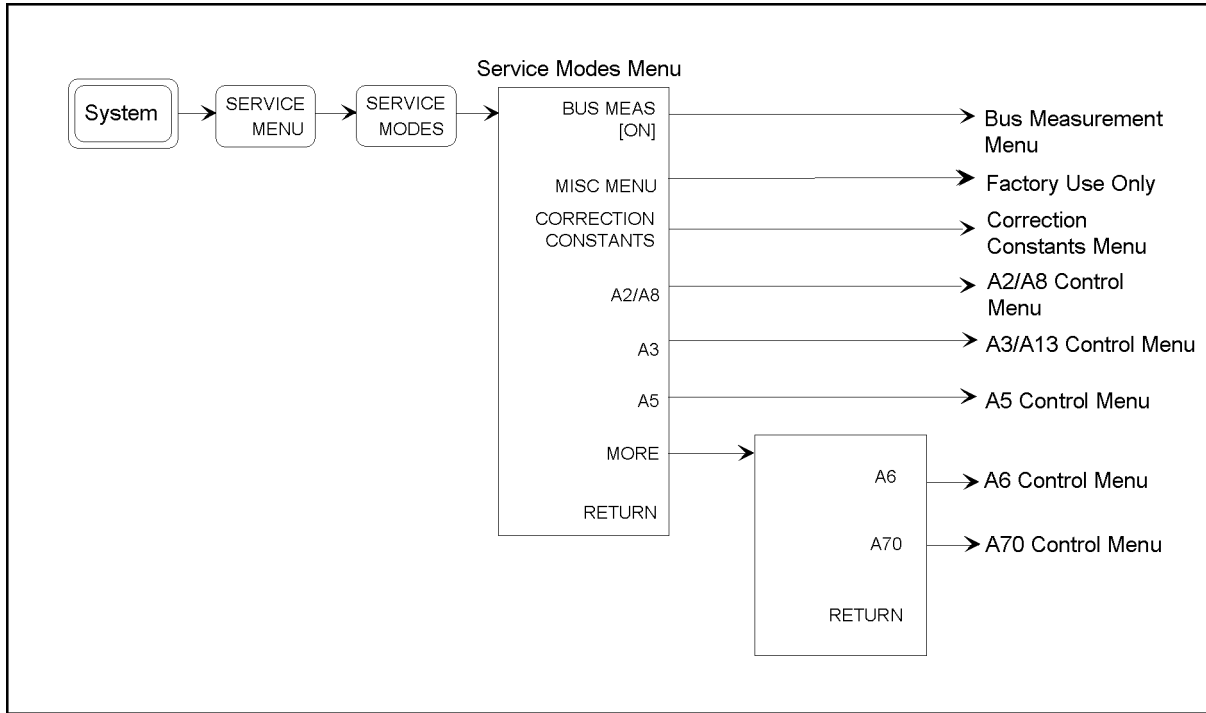

CDS09010

Figure 9-6. Service Modes Menu

BUS MEAS [ON]

Displays the Bus Measurement Menu. See the *Bus Measurement Menu* in this chapter.

MISC MENU

Displays the Miscellaneous Menu. See the *Miscellaneous Menu* in this chapter.

CORRECTION CONSTANTS

Displays the Correction Constant Menu. See the *Correction Constant Menu* in this chapter.

A2/A8

Displays the A2/A8 Menu. See the *A2/A8 Menu* in this chapter.

A3

Displays the A3/A13 Menu. See the *A3/A13 Menu* in this chapter.

A5

Displays the A5 Menu. See the *A5 Menu* in this chapter.

A6

Displays the A6 Menu. See the *A6 Menu* in this chapter.

A70

Displays the A70 Menu. This menu is factory use only.

Service Modes

The analyzer has various service modes. These service modes are powerful tools to test, verify, and troubleshoot the analyzer. The service modes are divided by function into the five groups listed below:

Bus Measurement	measures and displays the signal voltage or frequency at the selected bus node of the analyzer. This service mode allows you to check the circuit operation by monitoring the circuit signal without accessing the inside of the analyzer.
Correction Constants On/Off	allows you to turn one (or more) of the corrections on/off.
A2/A8	allows you to control the internal circuit settings in the A8 input attenuator, and to see the power fail status on the A2 post regulator.
A3/A13	allows you to control the internal circuit settings in the A3/A13 source.
A5	allows you to control the internal circuit settings in the A5 second PLL.
A6	allows you to control the internal circuit settings in the A6 spectrum analyzer.
A70	allows you to control the internal circuit settings in the A70 .

Note



After pressing **SERVICE MODES** , an annotation (Svc) is displayed to indicate that the service modes are activated. The settings made in the service modes are kept until the analyzer is turned off or **Preset** is pressed.

BUS MEASUREMENT MENU

Figure 9-7 shows the bus measurement menu. This menu is used to control the bus measurements. For more information about the bus measurements, see the *Bus Measurement*. For the bus measurement procedure, see the *Bus Measurement Procedure*.

To display the bus measurement menu, press `(System)`, `SERVICE MENU`, `SERVICE MODES`, and `BUS MEAS []`. Each softkey in the bus measurement menu is described below.

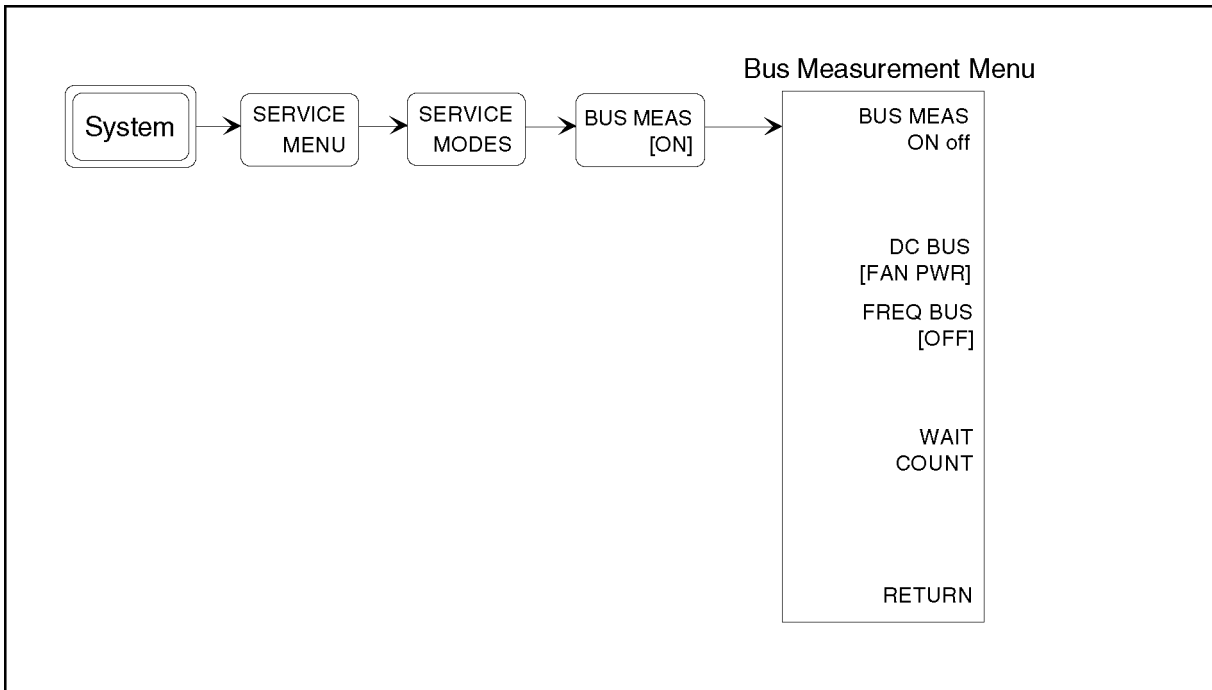

CDS09009

Figure 9-7. Bus Measurement Menu

`BUS MEAS ON off` (:DIAG:SERV:BUS:STAT {ON|OFF|1|0})

Toggles the bus measurement on and off. After pressing this softkey, the menu changes to `BUS MEAS on OFF` and the measured value of the bus measurement is displayed.

`DC BUS [FAN PWR]` (:DIAG:SERV:BUS:DC <numeric>)

Allows you to select one of the DC bus nodes. The DC bus nodes are numbered from 0 to 51. To select the desired DC bus node, press this softkey and then enter the node number by using the numeric keypad, `(↑)`, `(↓)`, or RPG knob. The node number and name are displayed in the active entry area of the display and the node abbreviation is displayed in the brackets of the menu.

FREQ BUS [OFF] (:DIAG:SERV:BUS:FREQ <numeric>)

Allows you to select one of the frequency bus nodes. The frequency bus nodes are numbered from 0 to 14. To select the desired frequency bus node, press this softkey and then enter the frequency node number by using the numeric keypad, \uparrow , \downarrow , or RPG knob. The node number and name are displayed in the active entry area of the display and the node abbreviation is displayed in the brackets of the menu.

WAIT COUNT (:DIAG:SERV:BUS:WAIT<numeric>)

Sets the wait count to specify the wait time in the DC bus measurement. The wait count is an integer from 1 to 32767. When the wait count is N, the analyzer waits $N * 12.5 \mu\text{sec}$ before each DC bus measurement.

Bus Measurement

In this service mode, the analyzer measures and displays the signal voltage or frequency at the selected bus node. This service mode allows you to check the circuit operation by monitoring the circuit signal without accessing the inside of the analyzer.

The analyzer has 28 bus nodes for this service mode. Of these, 28 bus nodes are for DC voltage measurement. These nodes are connected to the A/D converter in the A6 through the DC Bus. The other 7 bus nodes are for frequency measurement. These nodes are connected to the frequency bus timer in the A1 CPU through the frequency bus.

Each of the DC bus nodes and the frequency bus nodes is described in the *DC Bus Nodes* and *Frequency Bus Nodes* in this section.

Bus Measurement Procedure

Use this procedure to perform the bus measurement.

1. Press **Preset** to initialize the analyzer.
2. Press **System**, **SERVICE MENU**, **SERVICE MODES**, **BUS MEAS** to display the bus measurement menu.
3. Select the desired bus node as follows:
 - If a DC bus measurement is desired, press **DC BUS [OFF]**. Then enter a node number between 1 and 52.
 - If a frequency bus measurement is desired, press **FREQ BUS [OFF]**. Then enter a node number between 1 and 14.
4. Press **BUS MEAS on OFF** to activate the bus measurement. The menu changes to **BUS MEAS ON off**. The DC or frequency bus measurement value is displayed in the marker value. See the *Bus Measurement Values* section.
5. Set the analyzer controls to the settings that you want to observe in the bus measurement.
6. Observe the bus measurement trace and marker value.
7. Press **Preset** to exit the bus measurement.

To change the bus node to another node, repeat the steps above.

The DC bus and the frequency bus can not be monitored simultaneously.

Bus Measurement Values

The bus measurement value is displayed with a unit “U”.

- The DC bus measurement’s “1 U” is equivalent to “1 V”. The displayed value in the DC bus measurement does not correspond to the measured voltage because the voltage detected at the DC bus node is scaled appropriately and measured. The scaling factor depends on each DC node. For example, the scaling factor at the DC bus node 1 of +5 V (AUX) is approximately 0.405. Therefore, the displayed value is nominally 2.025 U (5 U x 0.405). A typical value for each DC bus node measurement is provided in the *DC Bus Node Descriptions*.
- The frequency bus measurement’s “1 U” is equivalent to “1 MHz”. For example, a measured value of 1 kHz is displayed as 1 mU. A typical value for each frequency bus measurement is provided in the *Frequency Bus Node Descriptions*.

DC Bus Node Descriptions

The following paragraphs describe the 26 DC bus nodes. They are listed in numerical order.

0: NONE

The DC bus is off. This is the default setting.

1: [A2] + 5 V (AUX) (2.025 U)

This node is located on the A2 post-regulator and detects the voltage of the +5 V (AUX) power supplied to the A2 post-regulator. The typical trace is flat at approximately +2.025 U (±10%).

2: [A2] –15 V (–1.92 U)

This node is located on the A2 post-regulator and detects the voltage of the +5 V (AUX) power supplied to the analog boards. The typical trace is flat at approximately –1.92 U (±10%).

3: [A2] –12.6 V (–2.124 U)

This node is located on the A2 post-regulator and detects the voltage of the –12.6 V power supplied to the probe power connectors on the front panel. The typical trace is flat at approximately –2.124 U (±10%).

4: [A2] –5 V (–2.025 U)

This node is located on the A2 post-regulator and detects the voltage of the –5 V power supplied to the analog boards. The typical trace is flat at approximately –2.025 U (±10%).

5: [A2] + 5 V (2.025 U)

This node is located on the A2 post-regulator and detects the voltage of the +5 V power supplied to the analog boards. The typical trace is flat at approximately +2.025 U (±10%).

6: [A2] + 5.3 V (2.1465 U)

This node is located on the A2 post-regulator and detects the voltage of the +5.3 V power supplied to the A3/A13 source. The typical trace is flat at approximately +2.1465 U (±10%).

7: [A2] + 8.5 V (1.8955 U)

This node is located on the A2 post-regulator and detects the voltage of the +8.5 V power supplied to the A3/A13 source. The typical trace is flat at approximately +1.8955 U (±10%).

8: [A2] +15 V (AUX) (1.92 U)

This node is located on the A2 post-regulator and detects the voltage of the +15 V (AUX) power supplied to the probe power connectors on the front panel. The typical trace is flat at approximately +1.8955 U ($\pm 5\%$).

9: [A2] +15 V (1.92 U)

This node is located on the A2 post-regulator and detects the voltage of the +15 V power supplied to the analog boards. The typical trace is flat at approximately +1.92 U ($\pm 10\%$).

10: [A2] +22 V (2.002 U)

This node is located on the A2 post-regulator and detects the voltage of the +22 V power supplied to the S-parameter test set through the TEST SET-I/O INTERCONNECT connector on the rear panel. The typical trace is flat at approximately +2.002 U ($\pm 10\%$).

11: [A2] FAN POWER

This node is located on the A2 post-regulator and detects the voltage of the FAN POWER (nominal 24 V) supplied to the fan on the rear panel. The typical trace is flat at approximately +2.3 U ($\pm 10\%$).

12: [A2] +65 V (2.0605 U)

(This node is not connected to the DC Bus.)

13 through 19: Not Assigned

These nodes are not assigned.

20: [A3] +20VB

This node is located on the A3/A13 source and detects the voltage of the +20 V supplied from DC-DC Converter. The typical trace is flat at approximately +2.0 U ($\pm 10\%$).

21: [A3] -5VB

This node is located on the A3/A13 source and detects the voltage of the -5 V supplied from DC-DC Converter. The typical trace is flat at approximately -0.5 U ($\pm 10\%$).

22: [A3] +25VC

This node is located on the A3/A13 source and detects the voltage of the +25 V supplied from DC-DC Converter. The typical trace is flat at approximately +2.5 U ($\pm 10\%$).

23: [A3] -5VC

This node is located on the A3/A13 source and detects the voltage of the -5 V supplied from DC-DC Converter. The typical trace is flat at approximately -0.5 U ($\pm 10\%$).

24: [A3] DC POWER

This node is located on the A3/A13 source and detects the output voltage of the DC POWER supplied to the A60 source LPF. The typical trace is flat, and the value is proportional to the specified DC POWER voltage when the DC POWER voltage is output.

25: [A3] DC CONTROL

This node is located on the A3/A13 source and detects the output voltage of the DC CONTROL supplied to the A60 source LPF. The typical trace is flat, and the value is proportional to the specified DC CONTROL voltage when the DC CONTROL voltage is output.

26 through 29: Not Assigned

These nodes are not assigned.

30: [A5] VCO VTUNE

This node is located on the A5 second PLL and detects the tuning voltage of the second PLL.

31: [A5] 2ND IF DC OFFSET

This node is located on the A5 second PLL and detects the voltage of the second IF DC offset. The typical trace is flat at $0\text{ U} \pm 0.12\text{ U}$.

32 through 39: Not Assigned

These nodes are not assigned.

40: [A6] AD VREF

This node is located on the A6 spectrum analyzer and detects the reference voltage of the A-D converter. The typical trace is flat at approximately $+200\text{ mU} (\pm 10\%)$.

41: [A6] REF LOOP VTUNE

This node is located on the A6 spectrum analyzer and detects the tuning voltage of the reference oscillator. The typical trace is flat at approximately $+1.1\text{ U} (\pm 10\%)$.

42: [A6] FIXED PLL VTUNE

This node is located on the A6 spectrum analyzer and detects the tuning voltage of the 4th local oscillator (fixed PLL). The typical trace is flat at approximately $+1.0\text{ U} (\pm 50\%)$.

43: [A6] FN LOOP VTUNE

This node is located on the A6 spectrum analyzer and detects the tuning voltage of the fractional N PLL.

44: [A6] PEAK DETECTOR

This node is located on the A6 spectrum analyzer and detects the input of the spectrum analysis function.

45: [A6] GND

This node is located on the A6 spectrum analyzer. To observe this node, perform the steps in the *Bus Measurement Procedure*. When this node is selected, the trace is typically flat and within $\pm 2.5\text{ mU}$.

46 through 49: Not Assigned

These nodes are not assigned.

50: [A6] SA PATH

This is different from the above DC BUS nodes. This selects the SA Path instead of DC BUS path as the input of A-D Converter. See the analog circuit block diagram.

51: [A6] MONITOR PATH

This is different from the above DC BUS nodes. This selects the MONITOR Path instead of DC BUS path as the input of A-D Converter. See the analog circuit block diagram.

Frequency Bus Node Descriptions

The following paragraphs describe the 6 frequency bus nodes. They are listed in numerical order.

0: OFF

The frequency bus is off. This is the default setting.

1: [A5] 2nd LOCAL

This node is located on A5 second PLL, and measures the loop back frequency of 2nd Local Oscillator.

2: [A5] FREQ COUNTER

This node is located on A5 second PLL, and measures the frequency input to the frequency counter. The displayed value is equal to $F \text{ (MHz)}/16$ (F: F_BUS frequency value).

3: [A5] FV CONVERTER

This node is located on A5 second PLL, and measures the frequency input to the FV converter.

4 through 9: Not Assigned

These notes are not assigned.

10: [A6] SAMPLE HOLD

This node is located in the A6 spectrum analyzer, and measures the frequency of the sampling hold signal. The typical trace is flat at approximately 80 mU ($\pm 10\%$).

11: [A6] FM FREQ

This node is located on the A6 spectrum analyzer, and measures the 1 kHz FM frequency derived from 4th LO OSC. The typical trace is flat at approximately 1 mU ($\pm 10\%$).

12: [A6] REF LOOP

This node is located on the A6 spectrum analyzer, and measures the loop back frequency of the REF OSC. The typical trace is flat at approximately 40 mU ($\pm 10\%$).

13: [A6] FIXED PLL

This node is located on the A6 spectrum analyzer, and measures the loop back frequency of the 4th LO OSC (fixed PLL). The typical trace is flat at approximately 200 mU ($\pm 10\%$).

14: [A6] FN LOOP

This node is located on the A6 spectrum analyzer, and measures the loop back frequency of the Fractional N OSC. The typical trace is flat at approximately 2.5 U ($\pm 10\%$).

CORRECTION CONSTANTS MENU

Figure 9-8 shows the correction constants menu. This menu allows you to turn off one (or more) of the corrections. When one (or more) corrections are turned off, the analyzer displays the raw measured data. You can check the raw characteristics of the source and receiver circuit. For the corrections, see the *Correction Constants*.

To display the menu, press **System**, **SERVICE MENU**, **SERVICE MODES**, and **CORRECTION CONSTANTS**. Each softkey in the correction constants menu is described below.

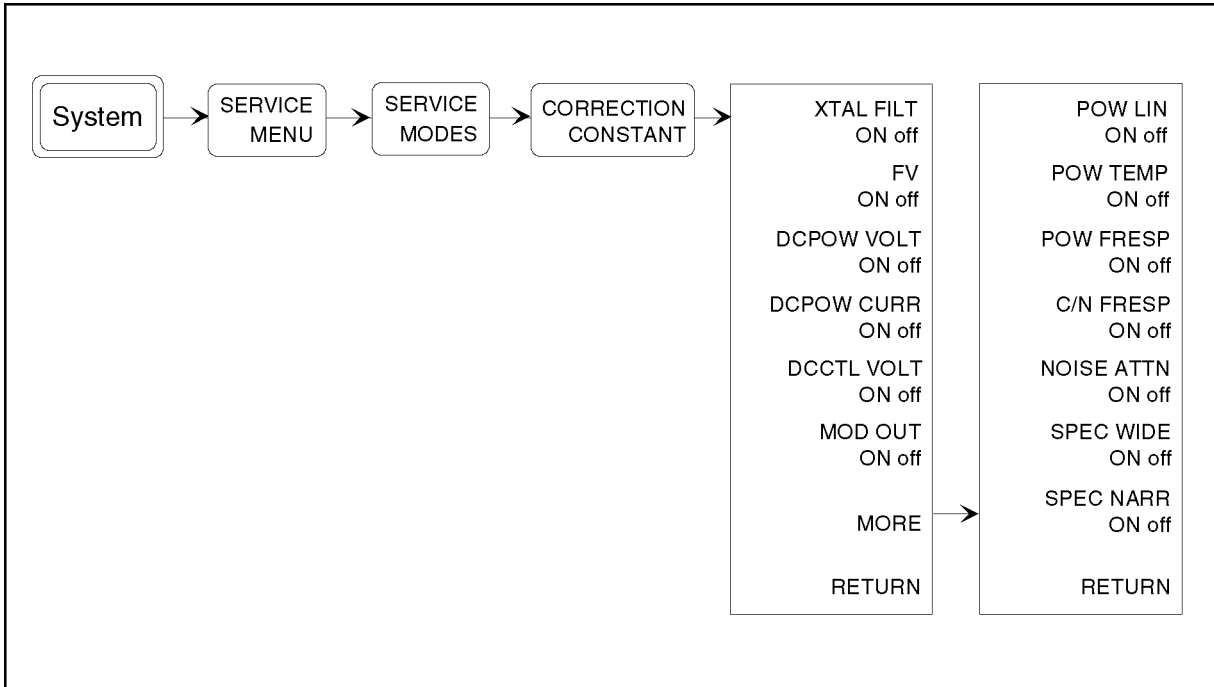

CDS09001

Figure 9-8. Correction Constants Menu

XTAL FILT ON off

Toggles the crystal filter frequency response correction on and off. This correction constant data is updated when performing *Crystal Filter Frequency Response Correction Constants*.

FV ON off

Toggles the FV converter correction on and off. This correction constant data is updated when performing *FV Converter Correction Constants*.

DCPOW VOLT CC ON off

Toggles the DC POWER output voltage correction on and off. This correction constant data is updated when performing *DC POWER Voltage Correction Constants*.

DCPOW CURR CC ON off

Toggles the DC POWER current measurement correction on and off. This correction constant data is updated when performing *DC POWER Current Correction Constants*.

DCCTL VOLT ON off

Toggles the DC CONTROL output voltage correction on and off. This correction constant data is updated when performing *DC CONTROL Voltage Correction Constants*.

MOD OUT ON off

Toggles the MOD output signal correction on and off. This correction constant data is updated when performing *MOD OUT Level Correction Constants*.

POW LIN ON off

Toggles the RF Power Linearity correction on and off. This correction constant data is updated when performing *RF Power Linearity Correction Constants*.

POW TEMP ON off

Toggles the RF Power Temperature correction on and off. This correction constant data is updated when performing *RF Power Linearity Correction Constants*.

POW FRESP ON off

Toggles the RF Power Frequency Response correction on and off. This correction constant data is updated when performing *RF Power Flatness Correction Constants*.

NOISE ATTN ON off

Toggles the Noise Attenuators correction on and off. This correction data is fixed and applicable for all 4352Bs. Therefore, the correction constants update is not required. When you replace a broken EEPROM with new one, this data is written by performing *EEPROM Write-ID and Initial Correction Constants*.

SPEC WIDE ON off

Toggles the spectrum analyzer absolute level correction on and off. This correction constant data is updated when performing *Spectrum Measurement Correction Constants*.

SPEC NARR ON off

Note

All corrections must be turned to on except when checking the analog circuits.



Note

The analyzer stores the above correction constants in the EEPROM on the A1 CPU. It uses them to control the internal circuits and to achieve optimum performance by compensating for errors due to circuit characteristics.



A2/A8 CONTROL MENU

Figure 9-9 shows the A2/A8 Control Menu hierarchy. To display the A2/A8 control menu, press **System**, **SERVICE MENU**, **SERVICE MODES**, and **A2/A8**. Each softkey of the A2/A8 control menu is described below.

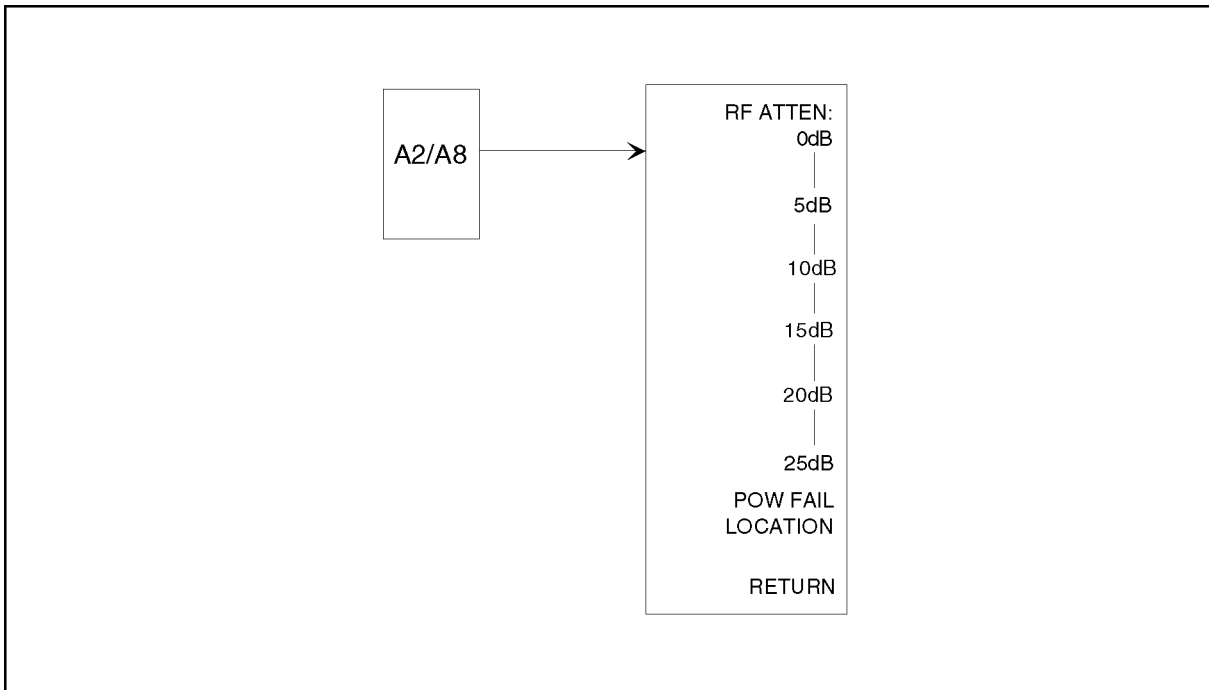

CAS09002

Figure 9-9. A2/A8 Control Menu

RF ATTEN :

Displays the control menu that allows you to control the A8 RF Attenuator setting. This is equal to the control of **RF ATTEN** under **Sense Range** key. You can set one of these attenuation values, 0 dB, 5 dB, 10 dB, 15 dB, 20 dB, and 25 dB by selecting the softkey.

POW FAIL LOCATION

Displays the power fail location address on the A2 post regulator when you press this key. If the displayed address is not “FFFF”, the A2 post regulator is probably faulty. Troubleshoot the power supply group by referring to the *Power Supply Troubleshooting* Chapter.

A3/A13 CONTROL MENU

Figure 9-10 shows the A3/A13 Source Control Menu hierarchy. To display the A3/A13 control menu, press **(System)**, **SERVICE MENU**, **SERVICE MODES**, and **A3**. Each softkey of the A3/A13 control menus is described below.

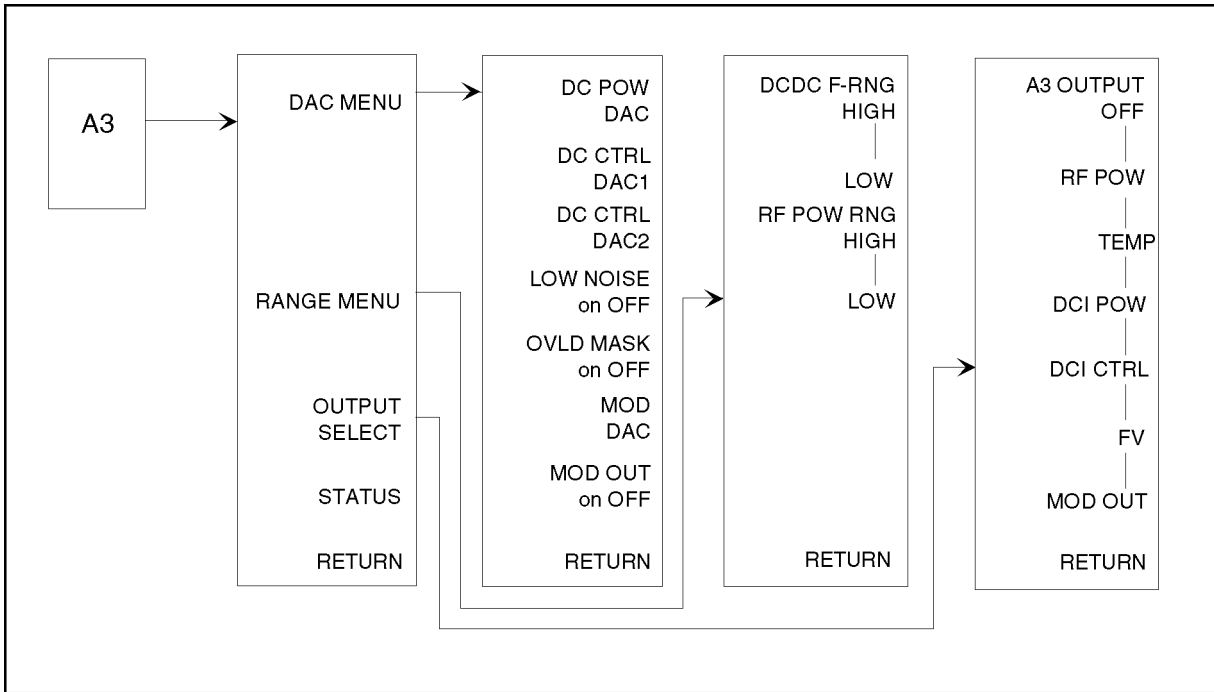

CDS09003

Figure 9-10. A3/A13 Control Menu

DAC MENU

Displays the control menu which allows you to control the DAC on the A3/A13 source for DC POWER/DC CONTROL/MOD OUT. Each softkey in these control menus is described below.

DC POW DAC	sets the DAC value for DC POWER output level.
DC CTRL DAC1	sets the DAC value to a coarse level setting for DC CONTROL output.
DC CTRL DAC2	sets the DAC value to a fine level setting for DC CONTROL output.
LOW NOISE on OFF	toggles the low noise filter for DC CONTROL output on and off.
OVLD MASK on OFF	sets the overload signal detection for DC POWER and DC CONTROL.
MOD DAC	sets the DAC for MOD OUT output level.
MOD OUT on OFF	toggles the MOD OUT signal output on and off.

RANGE MENU

Displays the control menu that allows you to control the switching frequency of the DC-DC Converter on the A3/A13 (DCDC F-RNG), and to control the power range for RF POWER measurement (RF POW RNG). This menu is for factory use only.

OUTPUT SELECT

Displays the control menu that allows you to select one of the following six nodes which outputs from the A3/A13 to the A6 spectrum analyzer.

RF POW	RF POWER signal from A9
TEMP	Thermometer value from A11
DCI POW	DC POWER Current
DCI CTRL	DC CONTROL Current
FV	FV Converter output from A5
MOD OUT	MOD OUT signal

STATUS

Displays the DC POWER/DC CONTROL Overload address on the A3/A13 source when you press this key. The displayed address is normally “FFFF” with nothing connections. If the different value is displayed, troubleshoot the source group by referring to the *Source Group Troubleshooting* Chapter.

A5 CONTROL MENU

Figure 9-11 shows the A5 Control Menu hierarchy. To display the A5 control menu, press **(System)**, **SERVICE MENU**, **SERVICE MODES**, and **A5**. Each softkey of the A5 control menus is described below.

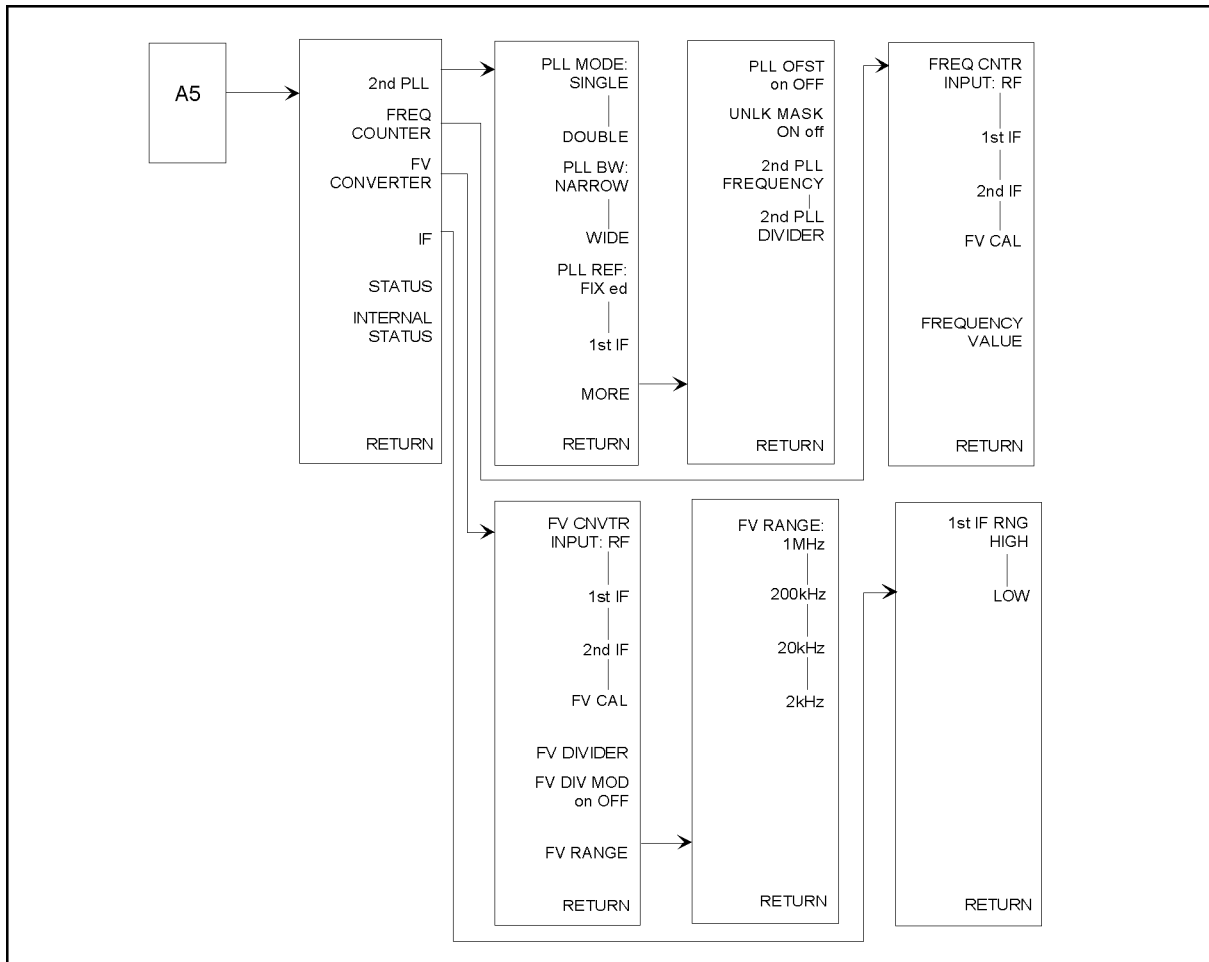

CAS09004

Figure 9-11. A5 Control Menu

2nd PLL

Displays the 2nd PLL menus. Each softkey of the 2nd PLL menus is described below.

2nd PLL:	sets the 2nd PLL to single loop mode or double loop mode.
PLL BW:	sets the 2nd PLL bandwidth to narrow mode or wide mode.
PLL REF:	assign the fixed signal or 1st IF signal as the reference signals of 2nd PLL.
PLL OFST on OFF	sets the 2nd PLL offsets lock mode to on and off.
UNLK MASK on OFF	sets the 2nd PLL unlock indicator to on and off.
2nd PLL FREQUENCY	shows the output frequency setting of 2nd PLL (2nd PLL FREQUENCY = 500 kHz x 2nd PLL Divider Value).
2nd PLL DIVIDER	sets the 2nd PLL divider (32 through 64).

FREQ COUNTER

FREQ CNTR INPUT	sets the input of the frequency counter out of the RF (RF), 1st IF (1st IF), 2nd IF (2nd IF), FM Deviation Calibration Signal (FV CAL).
FREQUENCY VALUE	shows the frequency counted value.

FV CONVERTER

Displays the control menu that allows you to control FV converter related circuits.

FV CNVTR INPUT:	selects one input signal out of four signals (RF signal from A10 (RF), 1st IF signal (1st IF), 2nd IF signal (2nd IF), and FV CAL signal for FM DEV CAL function from A6 (FV CAL).
FV DIVIDER	sets the FV Divider value.
FV DIV MOD on OFF	sets the FV DIV MOD switch ON/OFF.
FV RANGE	sets the FM Deviation Range to 2 kHz(2kHz), 20 kHz(20kHz), 200 kHz(200kHz), or 1 MHz(1MHz).

IF

Displays the 1st IF Range Selection Menu that allows you to set the 1st IF range to HIGH or LOW.

STATUS

Displays the phase lock status of the 2nd PLL. The displayed address is normally "FFF1". If a different value is displayed, troubleshoot the receiver group by referring to the *Receiver Group Troubleshooting* Chapter.

INTERNAL STATUS

Displays the status of the 2nd PLL, Frequency Counter, and FV Converter. The displayed address depends on the 4352B settings.

A6 CONTROL MENU

Figure 9-12 shows the A6 Control Menu hierarchy. To display the A6 control menu, press **System**, **SERVICE MENU**, **SERVICE MODES**, **MORE**, and **A6**. Each softkey of the A6 control menu is described below.

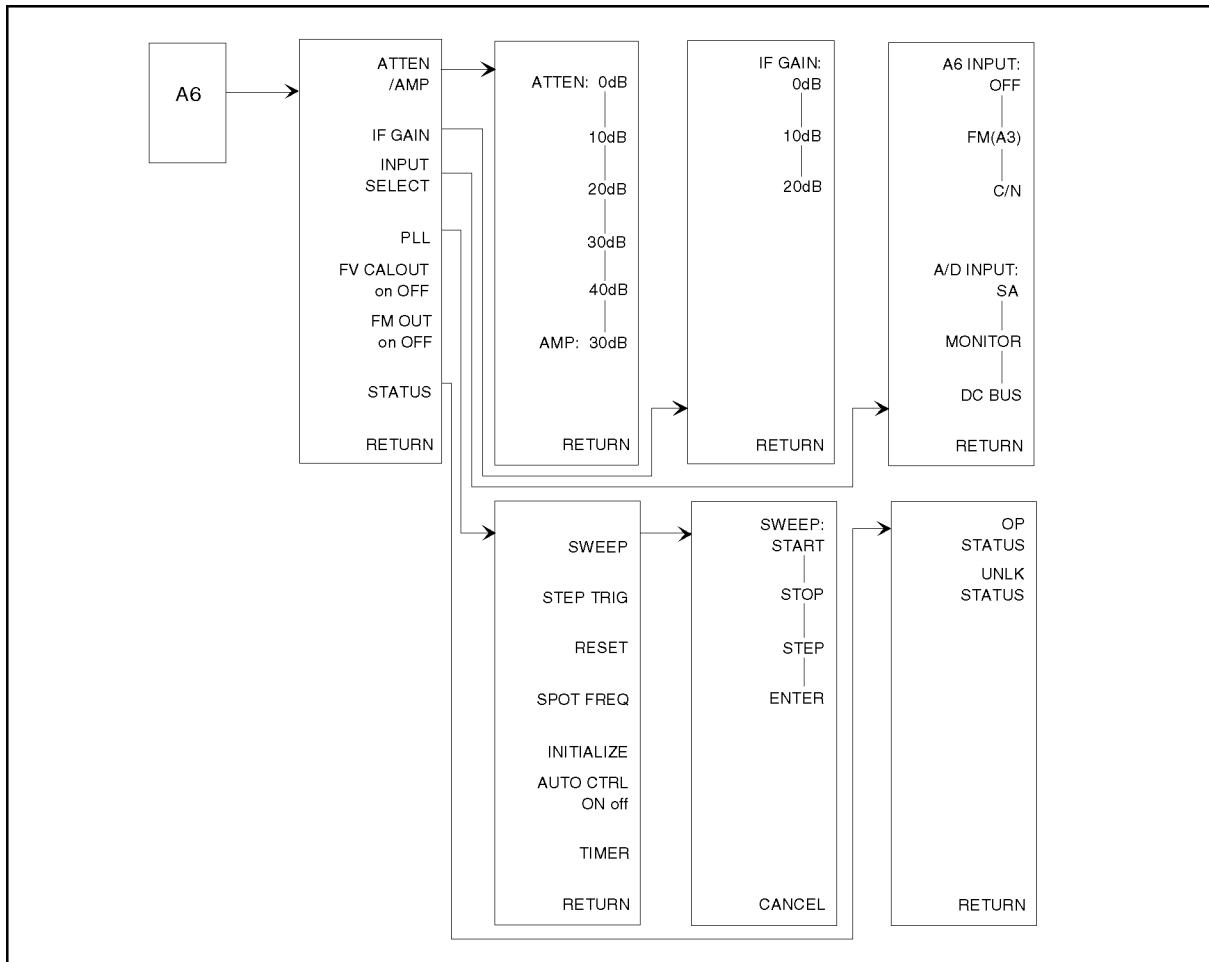

CAS09005

Figure 9-12. A6 Control Menu

ATTEN/AMP

Displays the control menu that allows you to select the input attenuator/special amplifier of the A6 spectrum analyzer Assembly. You can select one of the following attenuator/special amplifier (ATT: 0 dB, 10 dB, 20 dB, 30 dB, 40 dB, and AMP: 30 dB). The input attenuator is equal to the attenuator of **NOISE ATTEN** under **Sense Range** when Phase Noise, Spectrum, or C/N ratio measurement is performed. The special attenuator is used for testing the DC POWER/DC CONTROL noise as in *Troubleshooting* Chapter.

IF GAIN

Displays the control menu that allows you to control the 4th IF Gain Amplifier of A6. You can select one of three gains (0 dB, 10 dB, 20 dB).

INPUT SELECT

Displays the control menu that allows you to select one of two signal paths (FM deviation signal path from A3/A13 (FM (A3)) and Carrier/Noise signal path from A5 (C/N) for A6 input (A6 INPUT), and it also allows you to select one of three paths (SA path (SA), Monitor path (MONITOR), and DC BUS path (DC BUS) for the A-D Converter input (A/D INPUT).

PLL

Displays the control menu that allows you to control the PLL circuit on the A6. Each softkey of the control menus is described below. However, SWEEP, STEP TRIG, RESET, and INITIALIZE are for factory use only. These menus are not described.

SPOT FREQ	determines the 3rd Local frequency generated by FRAC N OSC (3rd LO = SPORT FREQ + 21.42 MHz).
AUTO CTRL ON off	toggles the internal frequency sweep on and off, even if the DC BUS node is tested.
TIMER	Sets the timer value for the A-D Converter.

FV CALOUT on OFF

Toggles the FV CAL signal output on and off.

FM OUT on OFF

Toggles the FM signal output (40 kHz) on and off.

STATUS

Displays the OP STATUS and UNLK STATUS keys.

When you press OP STATUS, the phase lock status of the FRAC N OSC or the input overload status is displayed. The displayed address is normally "FFFF". If a different value is displayed, troubleshoot the receiver group by referring to the *Receiver Group Troubleshooting* Chapter.

When you press UNLK STATUS, the phase lock status of the REF OSC and 4th LO OSC on the A6 is displayed. The displayed address is normally "FFFF". If the different value is displayed, troubleshoot the receiver group by referring to the *Receiver Group Troubleshooting* Chapter.

BOOTLOADER MENU

Figure 9-13 shows the Bootloader menus and the associated menus. To display the menu, turn the analyzer on while pressing (DC Control) and (Preset). The Bootloader menu is used to install the firmware into the analyzer using a firmware disk and the built-in FDD. Also, these menus are used to make a system backup disk. Each softkey in the Bootloader menu is described below.

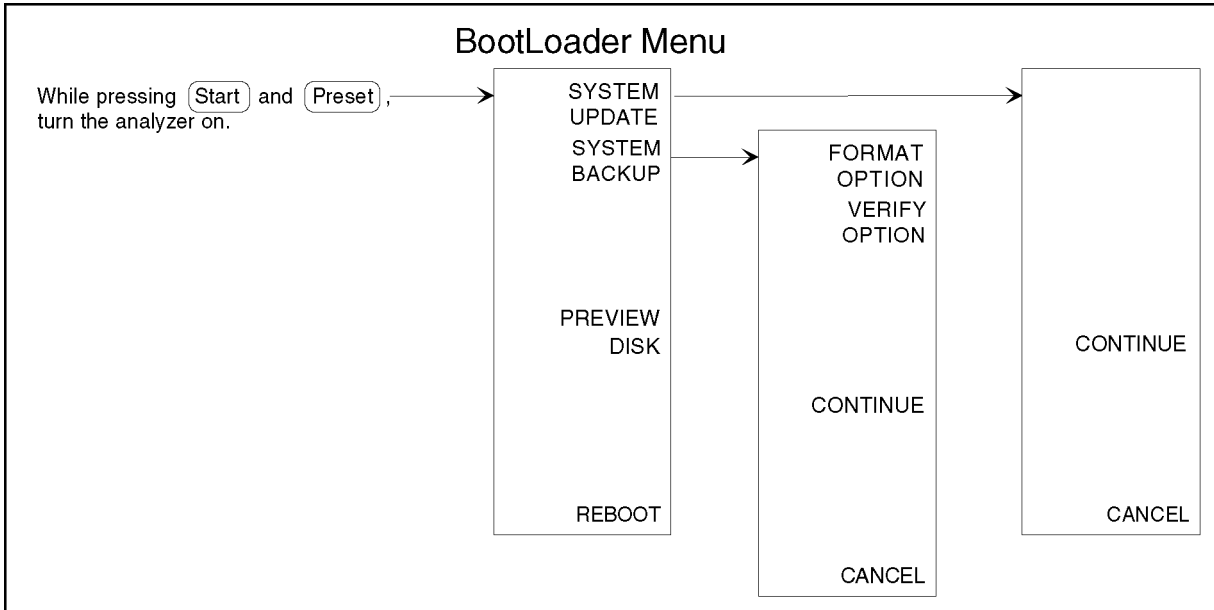

CAS09006

Figure 9-13. Bootloader Menu

SYSTEM UPDATE

Allows you to install and update the firmware in the analyzer. Before pressing this softkey, insert the firmware disk into the FDD on the front panel. Then press this softkey to install the firmware from the disk to the analyzer. The detailed procedure is provided in the *Firmware Installation* in Post-Repair Procedures chapter.

After pressing this softkey, **CONTINUE** and **CANCEL** softkeys appear on the display. Press **CONTINUE** to continue the firmware installation. Press **CANCEL** to cancel the firmware installation.

SYSTEM BACKUP

Displays the control menu that allows you to make a system backup disk in which the current firmware is stored. The applicable disk is a 3.5 inch 1.44 MByte flexible disk. The softkeys in the control menu are described below.

FORMAT OPTION toggles format option on and off. When the format option is set to on, the flexible disk is formatted before storing the firmware. When the format option is set to off, the disk is not formatted. The default setting is on. The format option setting is displayed as shown below.

```
Backup Options
Format Disk      : ON (or OFF)
Verify Data     : ON (or OFF)
```

Note

This option is available on Bootloader revision 1.01 and above. Before performing SYSTEM BACKUP, the flexible disk must be initialized as LIF format when the bootloader revision is 1.00.

VERIFY OPTION toggles verify option on and off. When the verify option is set to on, the system stored in the flexible disk is verified to be the same as the current firmware in the analyzer. When the verify option is set to off, the verification is not performed. The default setting is on. The verify option setting is displayed as shown above.

CONTINUE continues making the system backup. Before pressing this softkey, insert a disk into the FDD on the front panel.

CANCEL stops making the system backup and returns to the Bootloader menu.

PREVIEW DISK

Displays the revision information of the firmware stored in the firmware disk as shown below. Before pressing this softkey, insert a firmware disk into the FDD on the front panel.

```
Update Disk Revision
4352B Format Disk REVN.NN : MON DD YEAR
```

where N.NN: Revision Number
 MON DD YEAR: Implementation Date (Month Day Year)

REBOOT

Reboots the analyzer. If the firmware is installed, the analyzer boots up using the new firmware. After pressing the softkey, the analyzer performs the normal power on sequence.

Theory of Operation

The theory of operation begins with a general description of the operation of a VCO/PLL signal analyzer. This description is followed by the detailed operating theory for the functional groups of the analyzer.

Each functional group consists of several assemblies that combine to perform basic instrument functions. These groups are the power supplies, the digital control, the source, and the receiver. The operation of each group is described to the assembly level only. Detailed component-level circuit theory is not provided in this manual.

Simplified block diagrams illustrate the operation of each functional group. The detailed analog section block diagram is provided at the end of this chapter.

OVERALL OPERATION AND FUNCTIONAL GROUPS

The 4352B consists of four main functional groups: a power supply, a digital control, a source, and a receiver. Each group consists of several major assemblies, and performs a distinct function in the analyzer. However, all the groups are interrelated to some extent and affect each other's performance.

Power Supply: The power supply functional group consists of the A40 preregulator, A50 DC-DC Converter and the A2 post-regulator. It supplies power to the other assemblies in the analyzer.

Digital Control: The digital control group consists of the A1 CPU, the A17 24 bit I/O Port, the A30 keyboard, the A31 I/O connector, the A32 Instrument BASIC interface, the A51 GSP (Graphics System Processor), the A52 LCD, and the A53 FDD (Flexible Disk Drive). These assemblies combine to provide digital control for the analyzer.

Source: The source group consists of the A3/A13 Source, the A60 DC Source, A70 DC Offset (Opt. 001 only) and a part of A6 Spectrum Analyzer. The source supplies DC Control, DC Power, and a 1 kHz Modulation Signal to the device under test.

Receiver: The receiver group consists of the A5 Second PLL, the A6 Spectrum Analyzer, the A7 Power Divider, the A8 RF Attenuator, the A9 Peak Detector, the A10 First Mixer, the A11 Thermometer, and a part of A3/A13 Source/A60 (as an ammeter/multiplexer). The receiver measures RF Inputs and processes them for display.

The following pages describe the operation of the functional groups.

POWER SUPPLY OPERATION

The power supply functional group consists of the following assemblies:

- A40 Preregulator
- A50 DC-DC Converter
- A2 Post-Regulator

These two assemblies comprise a switching power supply that provides regulated DC voltages to power all assemblies in the analyzer. See Figure 10-1.

The A40 preregulator steps down and rectifies the line voltage, and provides +24 V to the A50 DC-DC converter.

The A50 DC-DC converter contains two switching regulators, and provides the following six power supply voltages.

+5 VD, +7.8 V, -7.8 V, +18 V, -18 V and +24 V

The +5 VD (+5 V digital supply) is fully regulated in A50 and is directly supplied to the A1 CPU. The other five power supplies are preregulated in A50 and go to the A2 post-regulator for final regulation. A50 receives the FAN LOCK signal from the fan through the A20 motherboard and the A2 post-regulator.

The A2 post-regulator filters and regulates the five power supply voltages from A50. It distributes the following eleven regulated voltages to individual assemblies throughout the analyzer:

FAN POWER (+24 V), +22 V, +15 V, +15 V (AUX), +8.5, +5.3 V, +5 V, -5 V, -12.6 V, -15 V

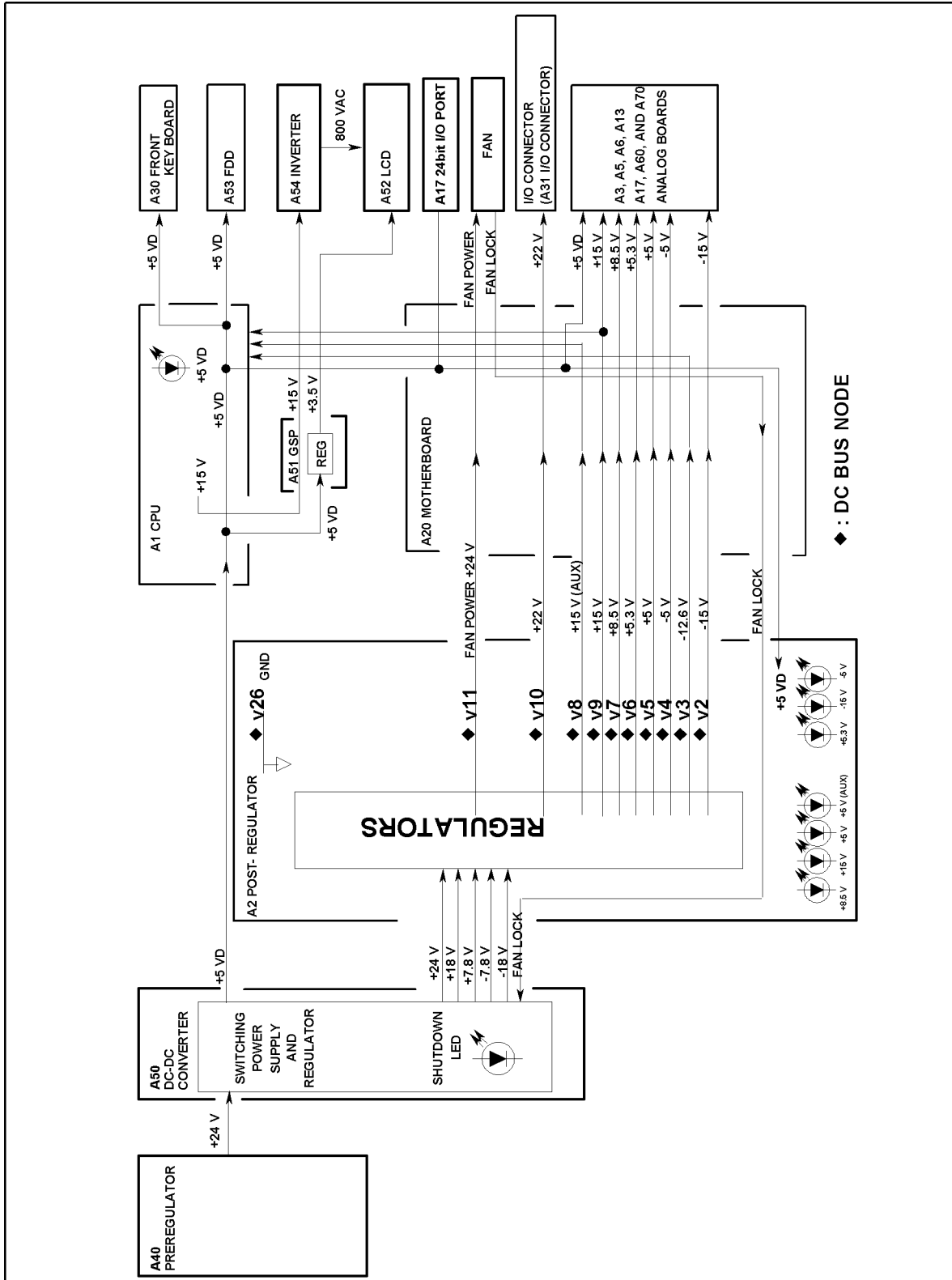

CDS05015

Figure 10-1. Power Supply Functional Group, Simplified Block Diagram

Line Power Module

The line power module includes the main fuse. The main fuse, which protects the input side of the preregulator from drawing too much line current, is also accessible at the rear panel. See *Power Requirements* in appendix B for the fuse replacement and other power considerations.

A40 Preregulator

The A40 preregulator contains a rectifier and a switching regulator, converts the line voltage to +24 V and provides it to the A50 DC-DC converter.

A50 DC-DC Converter

The A50 DC-DC Converter consists of the two switching regulators (1 and 2). The DC-DC converter provides an LED (green) to indicate circuit status. See Figure 5-11 in chapter 5. The shutdown LED is turned off when the overcurrent protection circuit activates. The circuit activates when an overcurrent is sensed on the +5 VD power line, when an overcurrent is sensed on the four power supplies (± 18 V and ± 7.8 V), or when the FAN LOCK signal is sensed. It shuts down the five power supplies of the switching regulators (1 and 2). For A50 to work properly, the +7.8 V must be loaded (approximately 680 ohms, more than 125mW). If it is not, the other preregulated voltages in the A50 DC-DC converter will not be correct.

Switching Regulator 1

Switching regulator 1 converts the +24 V to the regulated +5 VD (digital supply). The +5 VD goes directly to the A1 CPU.

Switching Regulator 2

Switching preregulator 2 converts the +24 V to four DC voltages, +7.8 V, -7.8 V, +18 V, -18 V. The voltages are routed to the A2 post-regulator for final regulation.

Regulated +5V Digital Supply (+5 VD)

The +5VD power supply is fully regulated in the A50 DC-DC converter. It goes directly to the A1 CPU and is supplied to all assemblies requiring a digital +5 V supply through A1, and the A20 motherboard.

A50 Shutdown LED

The A50 shutdown LED is on during normal operation. It turns off when the A50 protective circuits are activated and shut down some power lines. The shutdown LED turns off when one of the following conditions is sensed:

- Overcurrent on +5 VD Power Line.
- Overcurrent on the four power supplies (± 18 V and ± 7.8 V)
- Fan is not rotating (FAN LOCK signal is sensed).

The fan obtains its power +24 V from A40 preregulator through the A50 DC-DC converter and the A2 post-regulator. When the power is missing, the FAN LOCK signal shuts the switching regulators down and turns the A50 shutdown LED off.

A2 Post-Regulator

The A2 post-regulator consists of seven filters, nine regulators, and the drive circuits for the A8 input attenuator. See Figure 5-12 in chapter 5.

The A2 post-regulator distributes the following eleven power supply voltages to individual assemblies throughout the analyzer. Each of the nine regulators receives the DC voltage pre-regulated in A50 through a filter and converts it to one of the fully regulated constant DC voltages listed below:

FAN POWER	is derived from the +24 V supply from A40. It powers the fan.
+22 V	is derived from the +24 V supply from A50. It goes to the A31 I/O connector.
+15 V	is derived from the +18 V supply from A50. It powers analog assemblies.
+15 V (AUX)	is derived from the +18 V supply from A50. It goes to the A1 CPU through A20 Motherboard.
+8.5 V	is derived from the +15 V supply regulated in the A2 post-regulator. It powers the analog assemblies.
+5.3 V	is derived from the +7.8 V supply from A50. It powers the analog assemblies.
+5 V	is derived from the +7.8 V supply from A50. It powers analog assemblies.
-5 V	is derived from the -7.8 V supply from A50. It powers analog assemblies.
-12.6 V	is derived from the -18 V supply from A50. It goes to the A1 CPU through A20 Motherboard.
-15 V	is derived from the -18 V supply from A50. It powers analog assemblies.

The A2 post-regulator is equipped with a protective shutdown circuit.

The A2 post-regulator provides two LED arrays, visible at the top edge of the A2 post-regulator. Each LED array consists of four LEDs and indicates the status of the seven power supplies.

Shutdown Circuit

Four regulators for power supplies, +15 V, +5 V, -5 V, and -15 V are equipped with the capability of sensing overcurrent, and overvoltage, undervoltage on their output lines. When a regulator senses one of these conditions, it triggers the protective shutdown circuit. The circuit is also triggered by an over temperature condition in A2.

The following power supplies are not shutdown:

FAN POWER, +22 V, -12.6 V, +15 V (AUX)

The shutdown circuit also provides the shutdown status to the A1 CPU. When the circuit is activated, it triggers the A1 CPU. The A1 CPU checks the shutdown status on the A2 post-regulator and displays a warning message. Then the analyzer stops its operation. Once the analyzer stops the operation, the front-panel keys are disabled. The only way to reset the analyzer is to turn the analyzer power off then on.

Seven Status LEDs

The seven status LEDs on the A2 post-regulator are on during normal operation. They indicate that the correct voltage is present in each supply. See Figure 10-2. If one (or more) of them is off or flashing, there is a problem in the corresponding power supply.

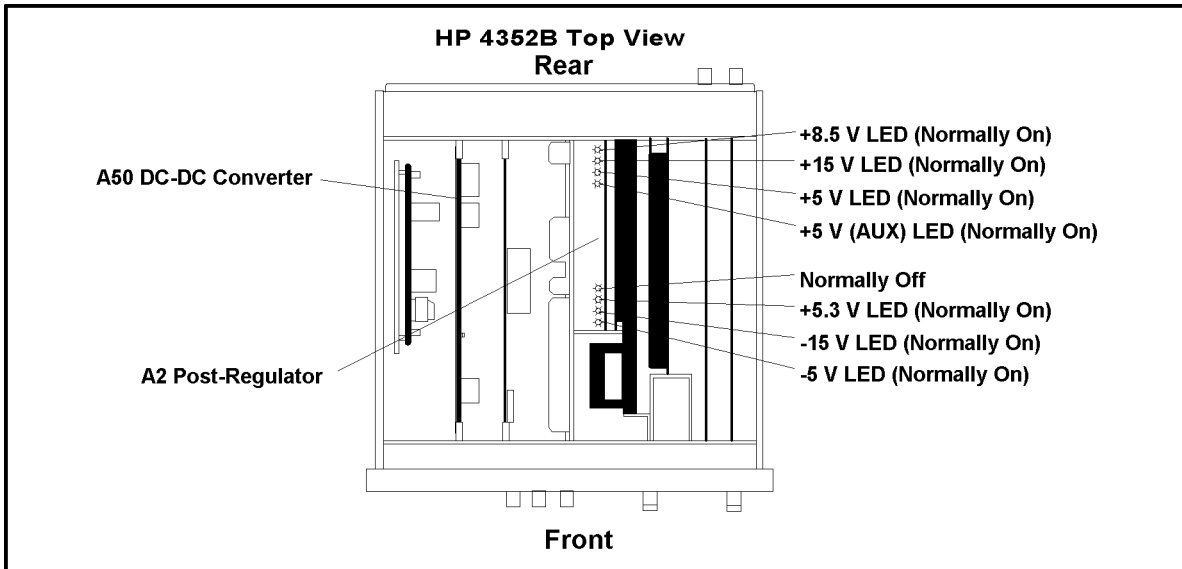

CDS05007

Figure 10-2. A2 Eight Status LED

A8 RF Attenuator Drive Circuit

The A2 post-regulator has the drive circuit for the A8 RF attenuator. The circuit decodes the control signal from the A1 CPU and generates the following TTL signals:

- A8 input attenuator drive signals (5 dB ON/OFF, 10 dB ON/OFF, 15 dB ON/OFF, 20 dB ON/OFF, 25 dB ON/OFF).

These signals are supplied to A8 through the A20 motherboard.

DIGITAL CONTROL OPERATION

The digital control functional group consists of the following assemblies:

- A1 CPU
- A17 24 bit I/O Port
- A30 Front Keyboard
- A31 I/O Connector
- A32 I-BASIC Interface
- A51 GSP
- A52 LCD
- A53 FDD (Flexible Disk Drive)

These assemblies combine to provide digital control for the analyzer. They provide math processing functions, as well as communications between the analyzer and an external controller and/or peripherals. Figure 10-3 is a simplified block diagram of the digital control functional group.

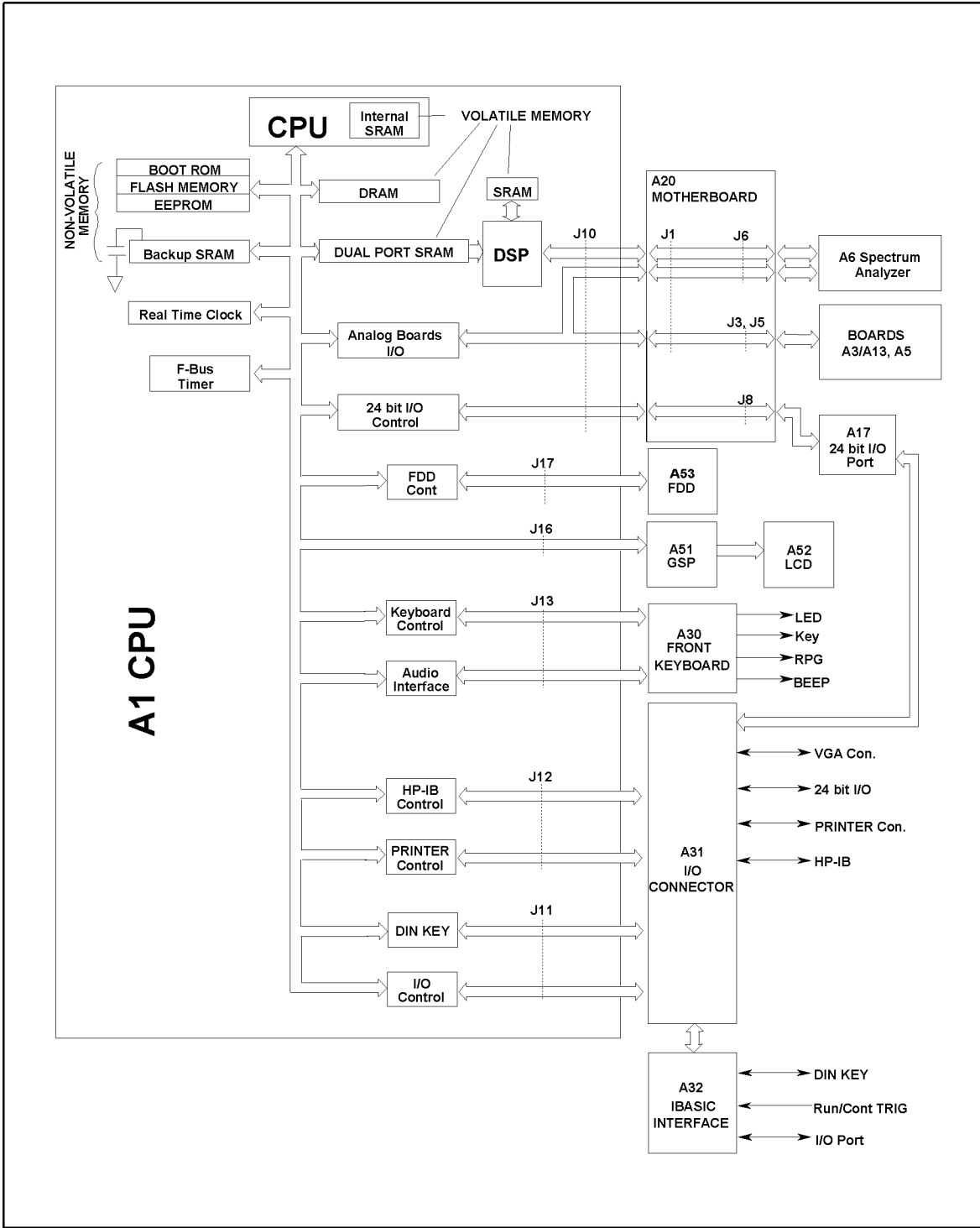

CDS06011

Figure 10-3. Digital Control Group Simplified Block Diagram

A1 CPU

The A1 CPU consists of the following circuits and parts (See Figure 10-3):

CPU	central processing unit that controls the analyzer.
DSP	digital signal processor that is used for fast data processing.
Memory storages	consists of BOOT ROMs, Flash Memory, EEPROM, Backup SRAM, DRAM, and Dual Port SRAM. The backup SRAM is powered from a large capacitor that is charged when the analyzer is turned on. Therefore, the SRAM keeps its data at least 72 hours after the analyzer is turned off. The Dual Port SRAM is used for communication between the CPU and DSP.
F-Bus Timer	is used in the frequency bus measurement that is a diagnostic function of the analyzer. For a description of the frequency bus measurement, see the <i>Service Key Menus</i> Chapter.
Analog Board Interface	interfaces between the CPU and analog assemblies.
24 bit I/O Control	controls the input/output from/to the 24 bit I/O port connector on the A31 I/O connector from/to the A17 24 bit I/O Port.
Keyboard Controller	controls the A30 front-panel keyboard.
Audio Interface	controls the beeper on the A30 front-panel keyboard.
FDD Control	controls the A53 FDD.
GPIB Control	communicates with the external GPIB devices through the GPIB connector on the A31 I/O connector.
mini-DIN Control	interfaces between the CPU and the external keyboard through the mini-DIN connector on the A32 I-BASIC Interface.
I/O Control	controls external devices through the I/O PORT connector on the A32 IBASIC interface. It also interfaces between the CPU and the external inputs through the EXT PROG RUN/CONT connector.

A17 24 Bit I/O Port

The A17 24 bit I/O port assembly interfaces the 4352B to an external handler, or the device under test (PLL circuit) through the A31 I/O connector.

A30 Front-Panel Keyboard

The A30 front-panel keyboard assembly detects your inputs (key inputs and RPG inputs) from the front panel of the analyzer, and transmits them to the keyboard controller on A1.

A31 I/O Connector

The A31 I/O connector is the board with two connectors: the GPIB connector and the 24 Bit I/O connector. These connectors are connected to the GPIB controller on the A1 through the A20 motherboard and the A17 24 bit I/O port assembly.

A32 I-BASIC Interface

The A32 I-BASIC Interface is the board with three connectors: the EXT PROG RUN/CONT connector, the I/O Port connector, and the mini-DIN connector. These connectors are connected to the I/O control and mini-DIN control circuit on A1 through the A20 motherboard.

A51 GSP

The A51 GSP (graphics system processor) provides an interface between the A1 CPU and the A52 LCD. The A1 CPU converts the formatted data to GSP commands and writes them to the A51 GSP. The A51 GSP processes the data to obtain the necessary signals and sends these signals to the A52 LCD

The A51 GSP receives two power supply voltages: +5 VD, which is used for data processing and converted to +3.3 V, and +15 V, which is passed on the A54 Inverter. The +3.3 V goes to the A52 LCD.

A54 Inverter

The A54 Inverter is located in the LCD module on the front panel assembly. The A54 receives +15 V from A1 CPU and provides a high voltage (800 to 1000 VAC) to the backlight of the LCD.

A52 LCD (Liquid Crystal Display)

The A52 LCD is a 8.4 TFT Color LCD, receives a high voltage (800 to 1000 VAC) from the A54 Inverter as backlight power and the digital horizontal and the vertical signals from the A51 GSP.

A53 FDD

The analyzer has a built-in, 3-1/2 inch FDD (Flexible Disk Drive) on the front panel. The high density or 2 double density 3-1/2 inch flexible disk is applicable. The A52 FDD reads and writes data to and from the flexible disk.

SOURCE THEORY

The 4352B generates the DC POWER voltage, the DC CONTROL voltage, and the MOD out modulation signal (1 kHz) on the front panel. See Figure 10-4.

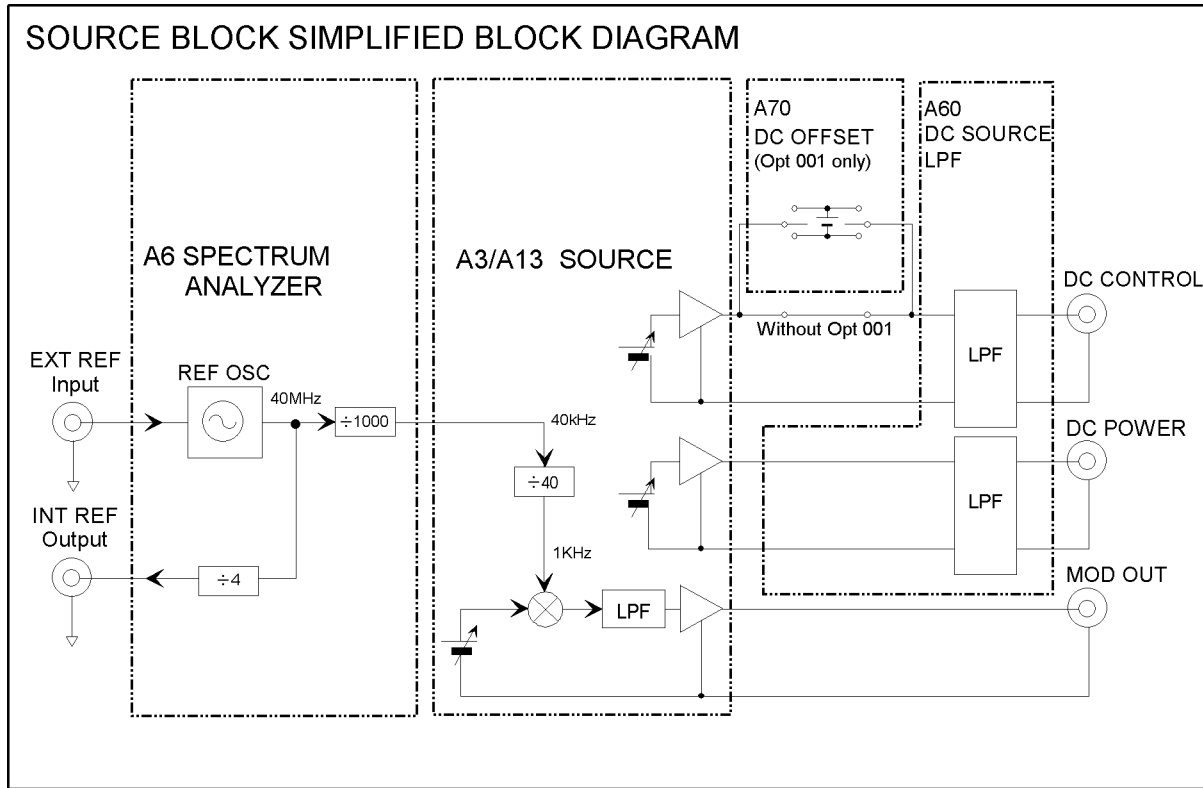

CDS07001

Figure 10-4. Source Group Simplified Block Diagram

The source group consists of the following assemblies:

- A3/A13 Source
- A60 DC Source LPF
- A part of A6 Spectrum Analyzer as a reference oscillator
- A70 DC Offset (Opt. 001 only)

Note



A3 is only an extender board which connects A13 Source to the A20 motherboard, and A3 appears to be a part of A13 as a connector. Therefore, the combination of the assembly numbers "A3/A13" is used even if the analog assembly is only A13.

A3/A13 Source consists of the DC POWER Source, the DC CONTROL Source, and the MOD OUT Source. The DC POWER Source, which includes a 12-bit D/A converter, generates the dc voltage from 0 V to 16 V with 1 mV resolution at the DC POWER connector through A60 DC Source LPF. The DC CONTROL Source, which includes two D/A converters (16 bit DAC (fine setting) and 12 bit DAC (coarse setting)), generates the dc voltage from 0 V to 20 V with 0.1 mV resolution to the DC CONTROL connector through A60 DC Source LPF. The MOD OUT Source generates 1 kHz signal whose level can be set from 0 to 1 V_{rms} with 1 mV_{rms} resolution. 1 kHz signal is derived from Reference Oscillator on A6, and is combined to 12-bit-DAC output in order to determine the MOD OUT level.

RECEIVER THEORY

The 4352B receives the input signal from RF IN connector on the front panel, and measures/analyzes the input signal according to the measurement item selected (RF POWER, FREQUENCY, C/N RATIO, DC POWER CURRENT, PHASE NOISE, RF TRANSIENT, SPECTRUM, and FM DEVIATION).

See Figure 10-5.

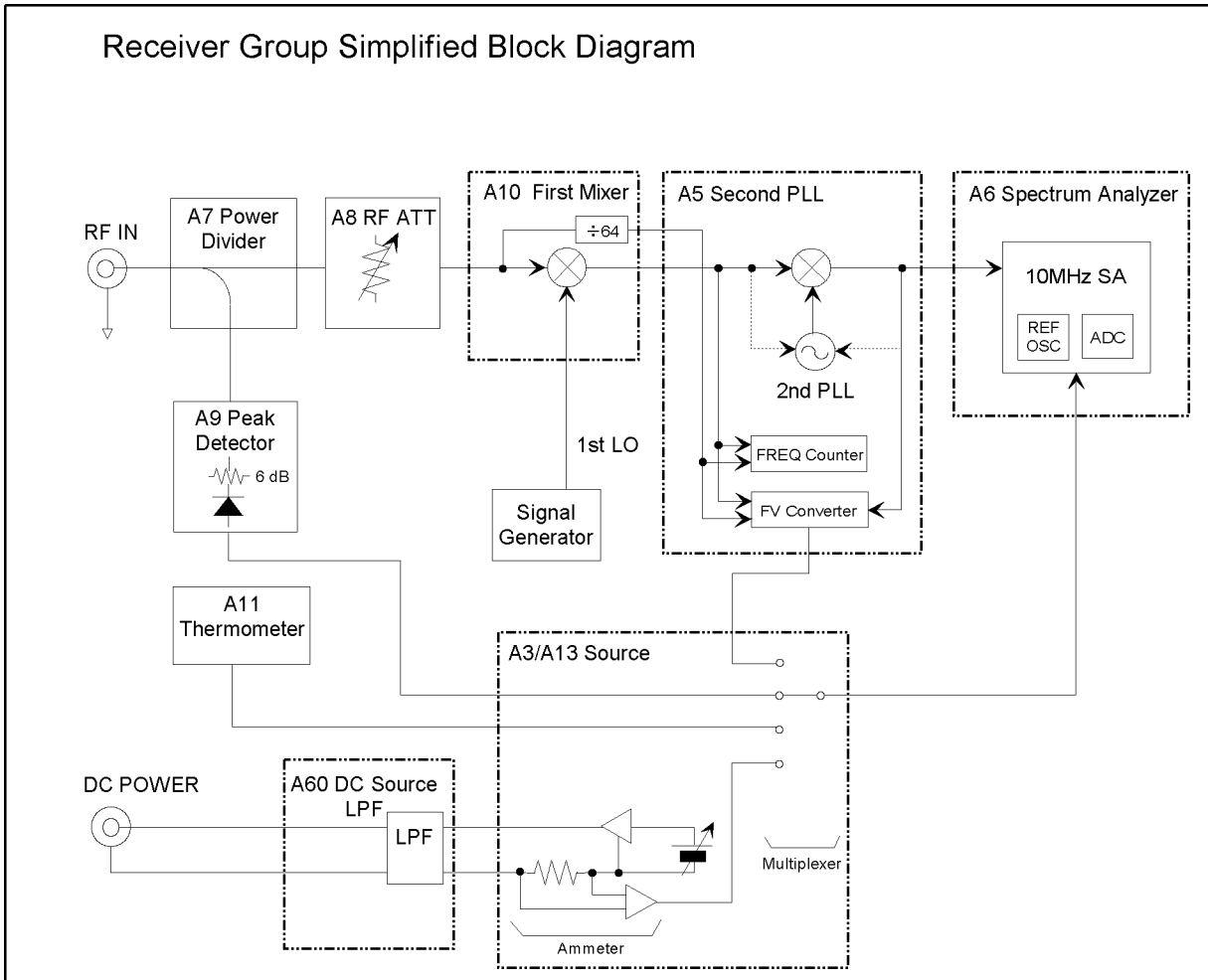

RECEIVER

Figure 10-5. Receiver Group Simplified Block Diagram

The receiver group consists of the following assemblies:

- A5 Second PLL
- A6 Spectrum Analyzer
- A7 Power Divider
- A8 RF Attenuator
- A9 Peak Detector
- A10 First Mixer
- A11 Thermometer
- A part of A3/A13 Source as an ammeter/multiplexer

A5 Second PLL

The A5 Second PLL consists of the 2nd local oscillator, the frequency counter, and the FV converter. The 2nd local oscillator generates the applicable signals to make the proper 2nd IF signal. The frequency counter is used to measure the frequency. In case of 64 kHz resolution selection, the frequency counter counts the signal, which is RF input signal/64. In case of 1 kHz resolution selection, the frequency counter counts the 1st IF signal. The FV converter converts the frequency into the voltage, and is used to make the FM deviation or the frequency transient measurement.

A6 Spectrum Analyzer

The A6 Spectrum Analyzer is used to make the spectrum measurement for C/N ratio, Phase Noise, and Spectrum. The Reference Crystal Oscillator is included on the A6, and derives all of the internal signals. The A-D Converter is also located on the A6, and is used for not only the normal measurements (Spectrum, C/N Ratio, etc.), but also service functions (DC BUS, etc.).

A7 Power Divider

The A7 Power Divider is used to divide the RF input signal into two. One goes to the A10 1st Mixer via A8 RF Attenuator. The other goes to the A9 Peak Detector.

A8 RF Attenuator

The A8 RF attenuator is a 5 dB step attenuator (0 dB to 25 dB). A8 is used to control the input signal level to the first mixer in the A10. The A8 setting can be controlled from the front panel directly.

A9 Peak Detector

The A9 Peak Detector is used to detect the RF input power level for RF Power measurement. The A9 is also used to check if there is the signal under test at the RF IN connector of the 4352B.

A10 First Mixer

The A10 First Mixer is to mix the RF input signal with the 1st local signal from the external signal generator, and used outputs the 1st IF signal. When the automatic signal generator control function is used, the 4352B controls the signal generator's settings (reset, output frequency setting, output level setting, and output on/off) via GPIB to make the proper 1st IF signal.

The 1st IF frequency depends on the RF input frequency. When the RF input frequency is ≥ 50 MHz, the 1st IF is within the range of $24 \text{ MHz} \pm 2.5 \text{ MHz}$. When the RF input frequency is < 50 MHz, the 1st IF is $(31.5 \text{ MHz} - \text{RF input freq. (MHz)} \times 0.15) \pm \text{RF input freq.} \times 0.05$. To generate the proper 1st IF, the 1st LO is set/re-set in accordance with the following (Note that the frequency range between 550 MHz and 600 MHz is the hysteresis zone):

- When RF input ≥ 550 MHz, 1st IF = RF input - 1st LO
- When RF input < 600 MHz, 1st IF = 1st LO - RF input

A11 Thermometer

The A11 Thermometer is used to measure the temperature around the A9 Peak Detector, and to compensate the RF power value of the A9 Peak Detector with the A11 Thermometer reading value.

A part of A3/A13, A60

The A3/A13/A60 not only generates the DC POWER/DC VOLTAGE/MOD OUT outputs, but also monitors the current of the DC POWER output. The A13 also contains a mutiplexer which selects one of several nodes to the A6 Spectrum Analyzer in accordance with the measurement item.

Replaceable Parts

Introduction

This chapter lists the analyzer's replaceable parts. How to order the parts is also described.

Ordering Information

To order a part listed in the replaceable parts table, quote the Agilent Technologies part number (with a check digit), indicate the quantity required, and address the order to the nearest Agilent Technologies office. The check digit will ensure accurate and timely processing of the order.

To order a part not listed in the replaceable parts table, include the instrument model number, the description and function of the part, and the quantity of parts required. Address the order to the nearest Agilent Technologies office.

Direct Mail Order System

Within the USA, Agilent Technologies can supply parts through a direct mail order system. Advantages of using this system are:

1. Direct ordering and shipment from the Agilent Technologies Parts Center in Mountain View, California.
2. No maximum or minimum on any mail order (there is a minimum order amount for parts ordered through a local Agilent Technologies office when the orders require billing and invoicing).
3. Prepaid transportation (there is a small handling charge for each order).
4. No invoices.

To provide these advantages, a check or money order must accompany each order.

Mail order forms and specific ordering information are available through your local Agilent Technologies office. Their addresses and phone numbers are located at the back of this manual.

Replaceable Parts List

The Replaceable parts table lists the following information for each part.

- 1 Agilent Technologies part number.
- 2 Part number check digit (CD).
- 3 Part quantity as shown in the corresponding figure. There may or may not be more of the same part located elsewhere in the instrument.
- 4 Part description, using abbreviations (see Table 11-2).
- 5 A typical manufacturer of the part in a five-digit code (see Table 11-1).
- 6 The manufacturer's part number.

Table 11-1. Manufacturers Code List

Mfr #	Name	Location	Zipcode
00779	AMP INC	HARRISBURG PA US	17111
06369	HIROSE ELECTRIC CO	JP	
06691	HOUSE OF METRICS LTD	SPRING VALLEY NY US	10977
08747	KITAGAWA KOGYO	TOKYO JP	
09635	TAJIMI MUSEN	TOKYO JP	
10572	XICOR INC	MILPITAS CA	
12085	SCHLEGEL CORP	ROCHESTER NY US	14692
13160	TEAC OF AMERICA INC	MONTEBELLO CA US	90640
28480	AGILENT TECHNOLOGIES CO CORPORATE HQ	PALO ALTO CA US	94304
28520	HEYCO MOLDED PRODUCTS	KENTWORTH NJ US	07033
73734	FEDERAL SCREW PRODUCTS CO	CHICAGO IL US	60618
76381	3M CO	ST PAUL MN US	55144
78189	ILLINOIS TOOL WORKS INC SHAKEPROOF	ELGIN IL US	60126

Table 11-2. List of Abbreviations

A	: amperes	N/C	: normally closed
A.F.C.	: automatic frequency control	NE	: neon
AMPL	: amplifier	NI PL	: nickel plate
B.F.O	: beat frequency oscillator	N/O	: normally open
BE CU	: beryllium copper	NPO	: negative positive zero (zero temperature coefficient)
BH	: binder head	NPN	: negative-positive-negative
BP	: bandpass	NRFR	: not recommended for field replacement
BRS	: brass	NSR	: not separately replaceable
BWO	: backward wave oscillator	OBD	: order by description
CCW	: counter-clockwise	OH	: oval head
CER	: ceramic	OX	: oxide
CMO	: cabinet mount only	P	: peak
COEF	: coefficient	PC	: printed circuit
COM	: common	p	: pico
COMP	: composition	PH BRZ	: phosphor bronze
COMPL	: complete	PHL	: Philips
CONN	: connector	PIV	: peak inverse voltage
CP	: cadmium plate	PNP	: positive-negative-positive
CRT	: cathode-ray tube	P/O	: part of
CW	: clockwise	POLY	: polystyrene
DE PC	: deposited carbon	PORC	: porcelain
DR	: drive	POS	: position(s)
ELECT	: electrolytic	POT	: potentiometer
ENCAP	: encapsulated	PP	: peak to peak
EXT	: external	PT	: point
F	: farads	PWV	: peak working voltage
f	: femto	RECT	: rectifier
FH	: flat head	RF	: radio frequency
FIL H	: fillister head	RH	: round head or right hand
FXD	: fixed	RMO	: rack mount only
G	: giga	RMS	: root-mean square
GE	: germanium	RWV	: reverse working voltage
GL	: glass	S-B	: slow-blow
GRD	: ground(ed)	SCR	: screw
H	: henries	SE	: selenium
HEX	: hexagonal	SECT	: section(s)
HG	: mercury	SEMICON	: semiconductor
HR	: hour(s)	SI	: silicon
Hz	: hertz	SIL	: silver
IF	: intermediate freq.	SL	: slide
IMPG	: impregnated	SPG	: spring
INCD	: incandescent	SPL	: special
INCL	: include(s)	SST	: stainless steel
INS	: insulation(ed)	SR	: split ring
INT	: internal	STL	: steel
k	: kilo	TA	: tantalum
LH	: left hand	TD	: time delay
LIN	: linear taper	TGL	: toggle
LK WASH	: lock washer	THD	: thread
LOG	: logarithmic taper	TI	: titanium
LPF	: low pass filter	TOL	: tolerance
m	: milli	TRIM	: trimmer
M	: meg	TWT	: traveling wave tube
MET FLM	: metal film	μ	: micro
MET OX	: metallic oxide	VAR	: variable
MFR	: manufacturer	VDCW	: dc working volts
MINAT	: miniature	W/	: with
MOM	: momentary	W	: watts
MTG	: mounting	WIV	: working inverse voltage
MY	: "mylar"	WW	: wirewound
n	: nano	W/O	: without

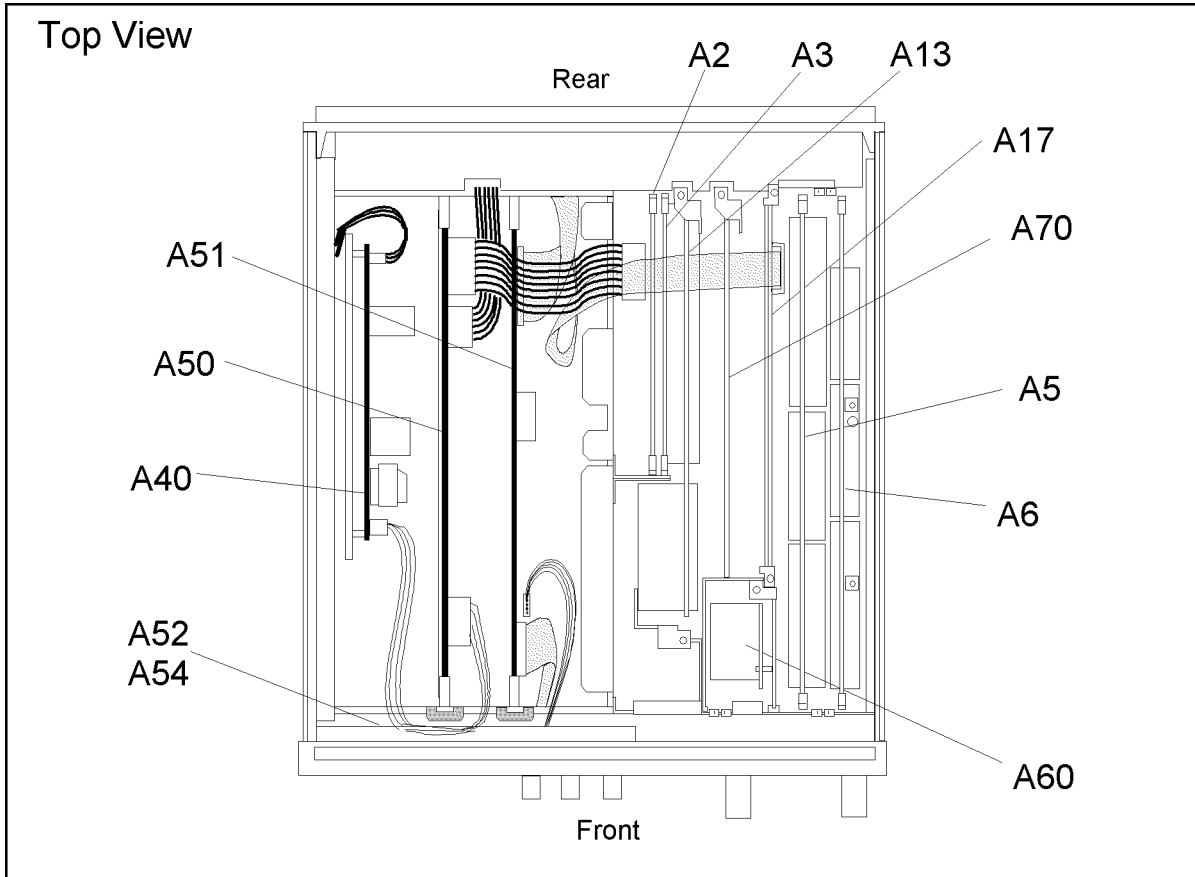

CDS11TOP

Figure 11-1. Top View

Table 11-3. Top View

Ref. Desig.	Agilent Part Number	C D	Qty.	Description	Mfr Code	Mfr Part Number
A52	2090-0534	8	1	LCD	28480	2090-0534
A51	E4970-66552	9	1	GSP Board	28480	E4970-66552
A50	E4970-66550	7	1	DC-DC Converter	28480	E4970-66550
A2	04396-66542	4	1	Post Regulator	28480	04396-66542
A3	04352-66503	5	1	Connector Board	28480	04352-66503
A13	04352-66513	7	1	DC/FM Source Board	28480	04352-66513
A17	04351-66517	0	1	24 Bit I/O Board	28480	04351-66517
A5	04352-66515	9	1	Receiver Board	28480	04352-66515
A6	04352-66506	8	1	Spe. Ana. Section Board	28480	04352-66506
A60	04352-66560	4	1	Output Filter	28480	04352-66560
A40	0950-3246	7	1	Preregulator	28480	0950-3246
A70	04352-66540	0	1	DC Offset (Opt.001 only)	28480	04352-66540
A54	0950-2924	6	1	Inverter Board	28480	0950-2924

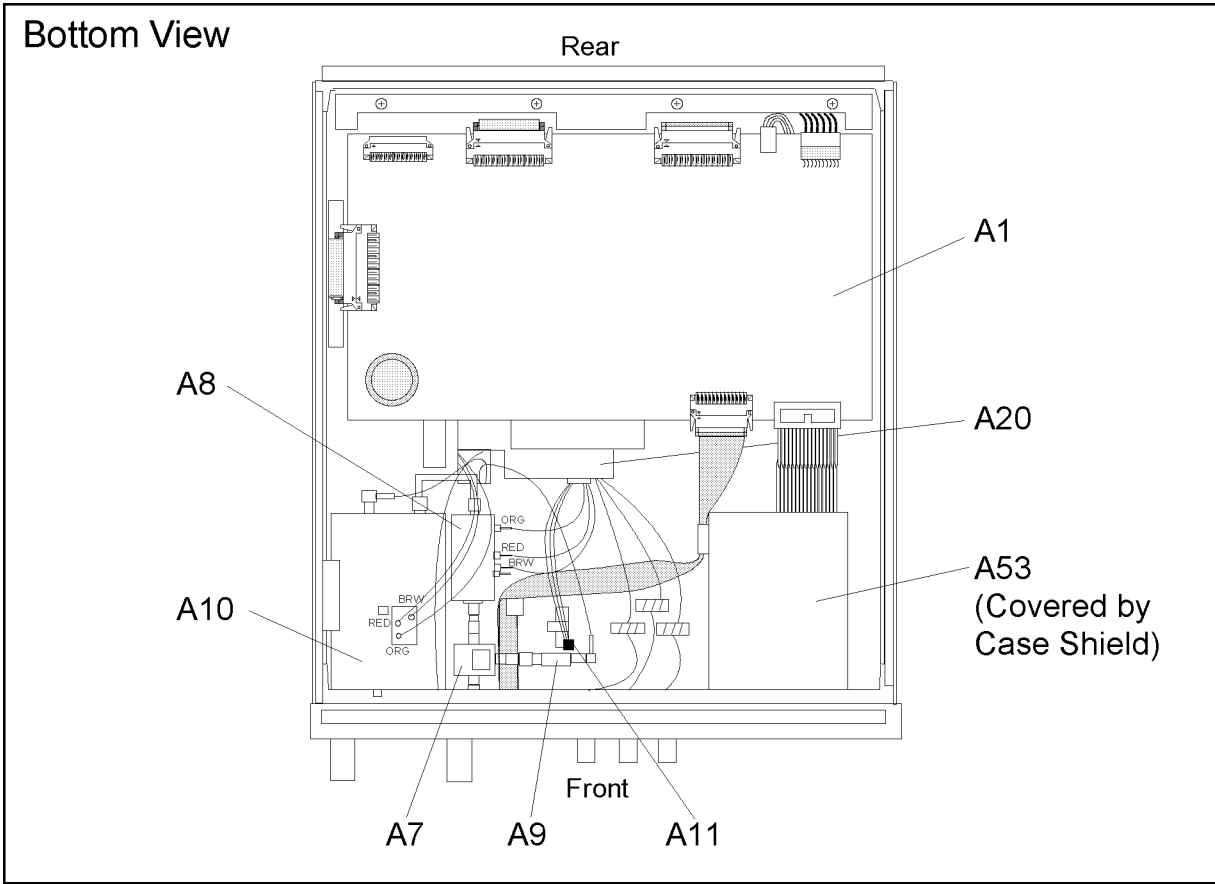

CDS11BTM

Figure 11-2. Bottom View

Table 11-4. Bottom View

Ref. Desig.	Agilent Part Number	C	D	Qty.	Description	Mfr Code	Mfr Part Number
A1	E4970-66501	8		1	CPU Board	28480	E4970-66501
A7	11636B	1		1	Power Divider	28480	11636B
A8	0955-1008	5		1	Step ATT	28480	0955-1008
A9	8471E#004	8		1	Peak Detector	28480	8471E#004
	0955-0971	9		1	ATT	28480	0955-0971
A10	04352-66516	0		1	1st Mixer Board	28480	04352-66516
A11	04352-61621	8		1	Thermometer	28480	04352-61621
A20	04396-66520	8		1	Motherboard	28480	04396-66520
A53	0950-3208	1		1	FDD	28480	0950-3208

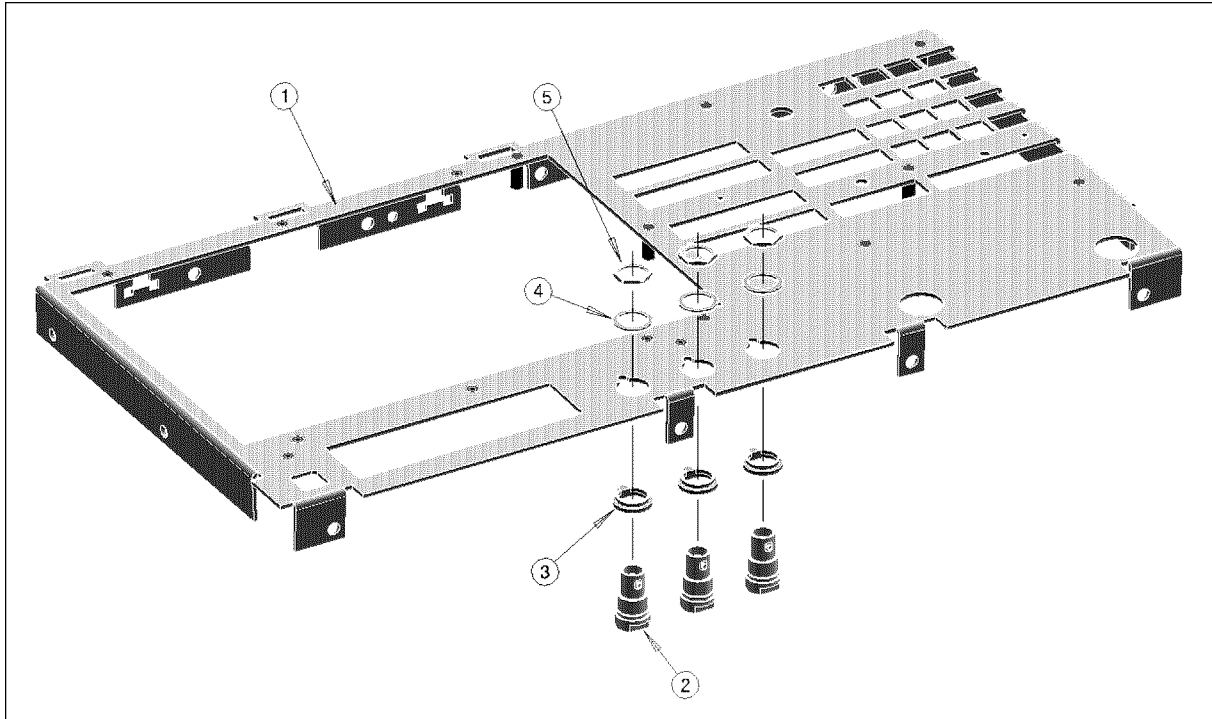

CDS11001

Figure 11-3. Front Assembly Parts 1

Table 11-5. Front Assembly Parts 1

Ref. Desig.	Agilent Part Number	C D	Qty.	Description	Mfr Code	Mfr Part Number
1	04352-00222	7	1	Panel Sub	28480	04352-00222
2	1250-0252	6	3	CONN-RF-BNC	28480	1250-0252
3	5040-3325	9	3	Insulator BNC	28480	5040-3325
4	5040-3324	8	3	Insulator BNC	28480	5040-3324
5	2950-0035	8	3	NUT-HEX-DBL-CHAM	28480	2950-0035

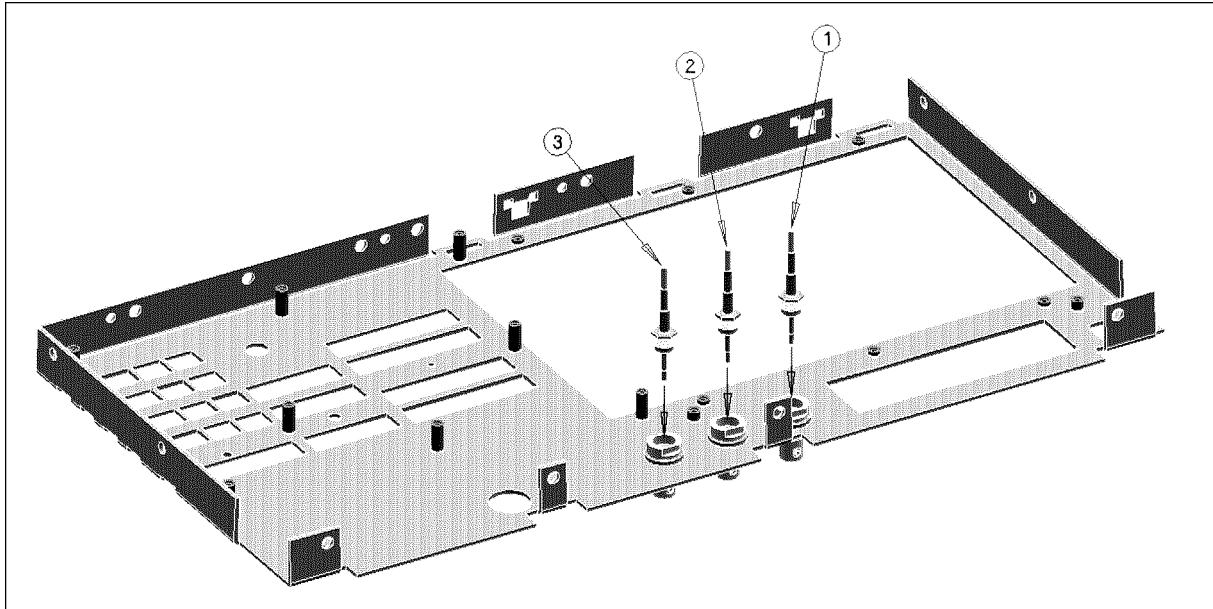

CDS11002

Figure 11-4. Front Assembly Parts 2

Table 11-6. Front Assembly Parts 2

Ref. Desig.	Agilent Part Number	C D	Qty.	Description	Mfr Code	Mfr Part Number
1	04351-61611	5	1	RF CBL ASSY	28480	04351-61611
2	04351-61614	8	1	RF CBL ASSY	28480	04351-61614
3	04351-61612	6	1	RF CBL ASSY	28480	04351-61612

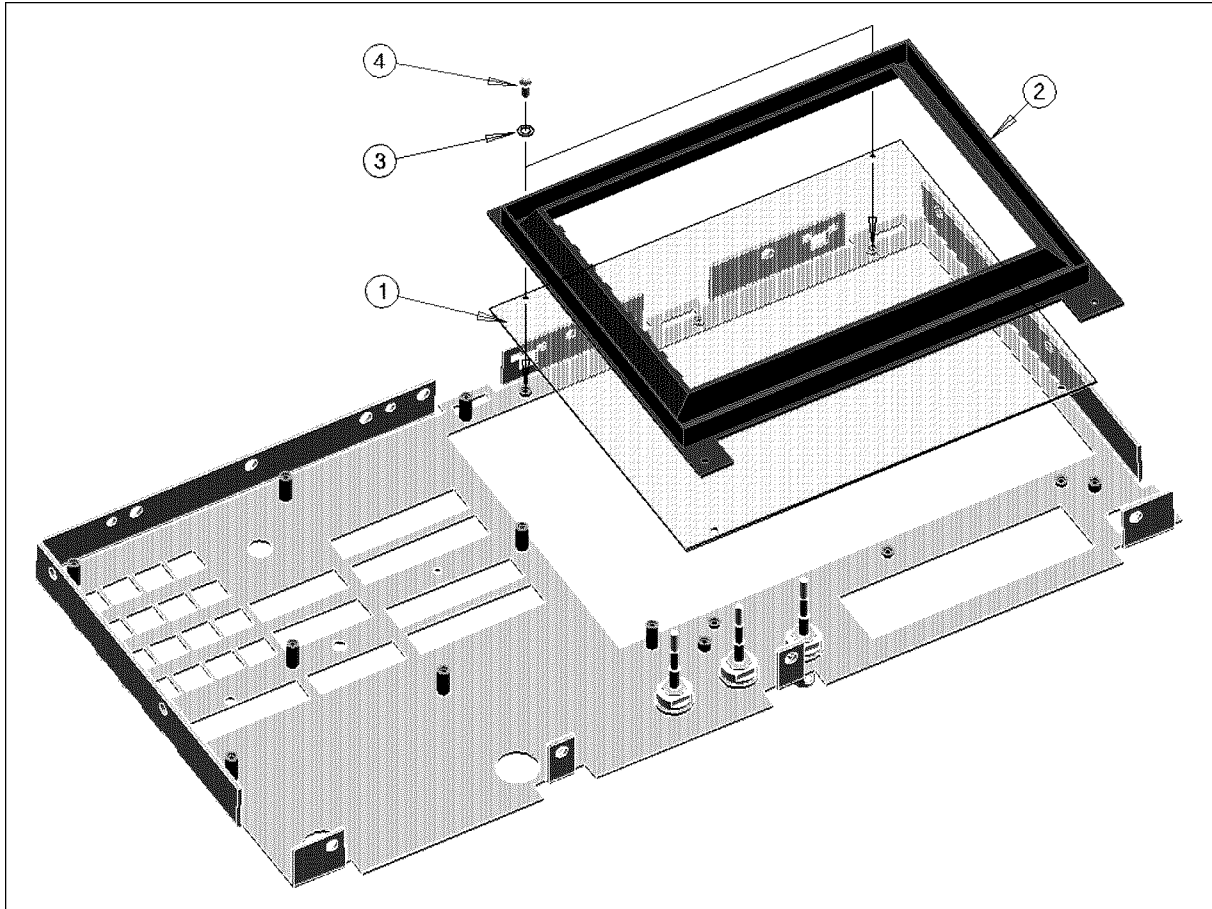

CDS11003

Figure 11-5. Front Assembly Parts 3

Table 11-7. Front Assembly Parts 3

Ref. Desig.	Agilent Part Number	C D	Qty.	Description	Mfr Code	Mfr Part Number
1	E4970-25001	7	1	Filter	28480	E4970-25001
2	04396-40071	0	1	Bezel Back	28480	04396-40071
3	3050-0891	7	2	Washer M3	28480	3050-0891
3	0515-1550	0	2	SCR M3-L 8 P-H	28480	0515-1550

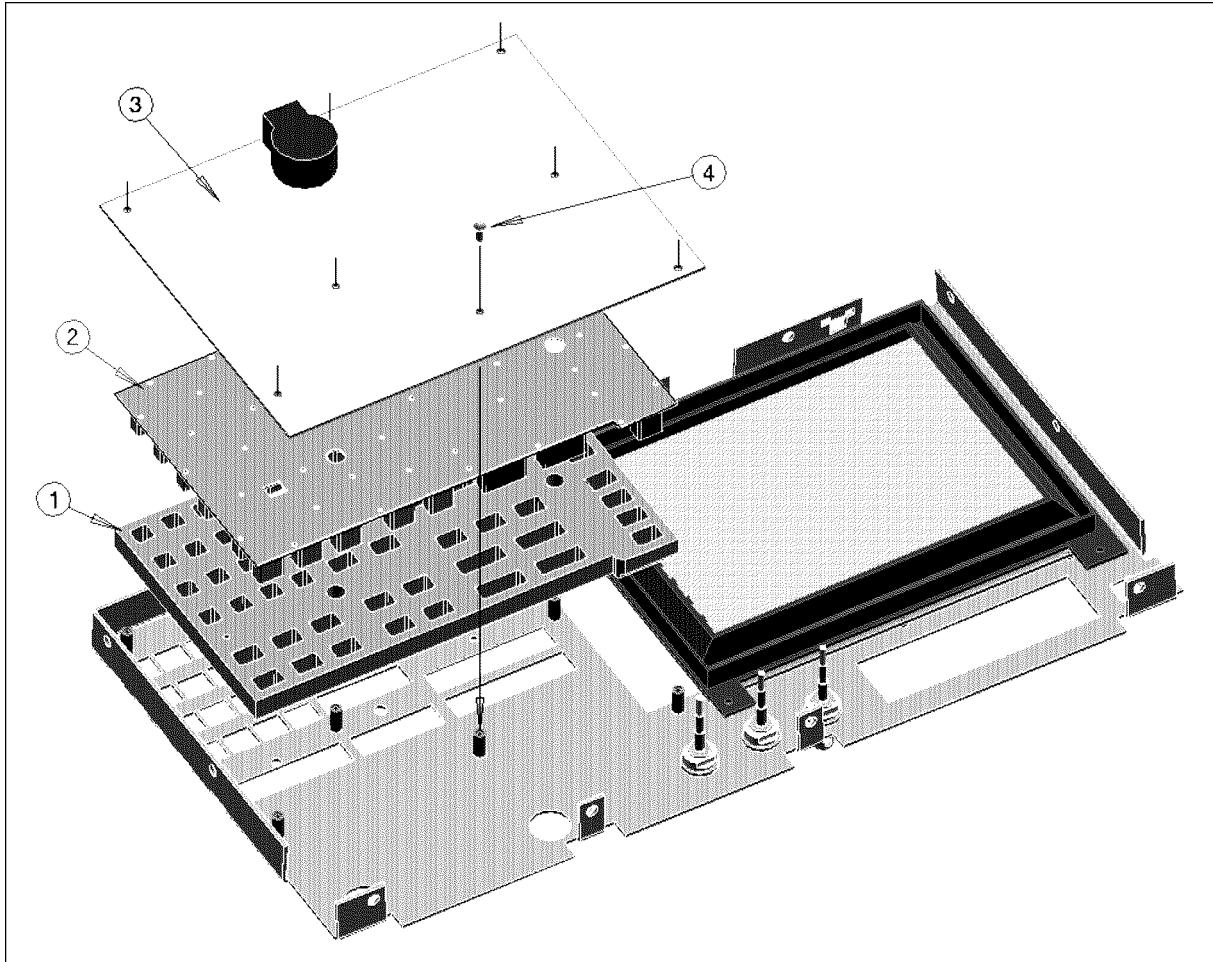

CDS11004

Figure 11-6. Front Assembly Parts 4

Table 11-8. Front Assembly Parts 4

Ref. Desig.	Agilent Part Number	C	D	Qty.	Description	Mfr Code	Mfr Part Number
1	04286-40001	3		1	Guide	28480	04286-40001
2	04352-25051	2		1	Rubber Key	28480	04352-25051
3	04352-66530	8		1	A30 Front Keyboard	28480	04352-66530
4	0515-1550	0		8	SCR M3-L 8 P-H	28480	0515-1550

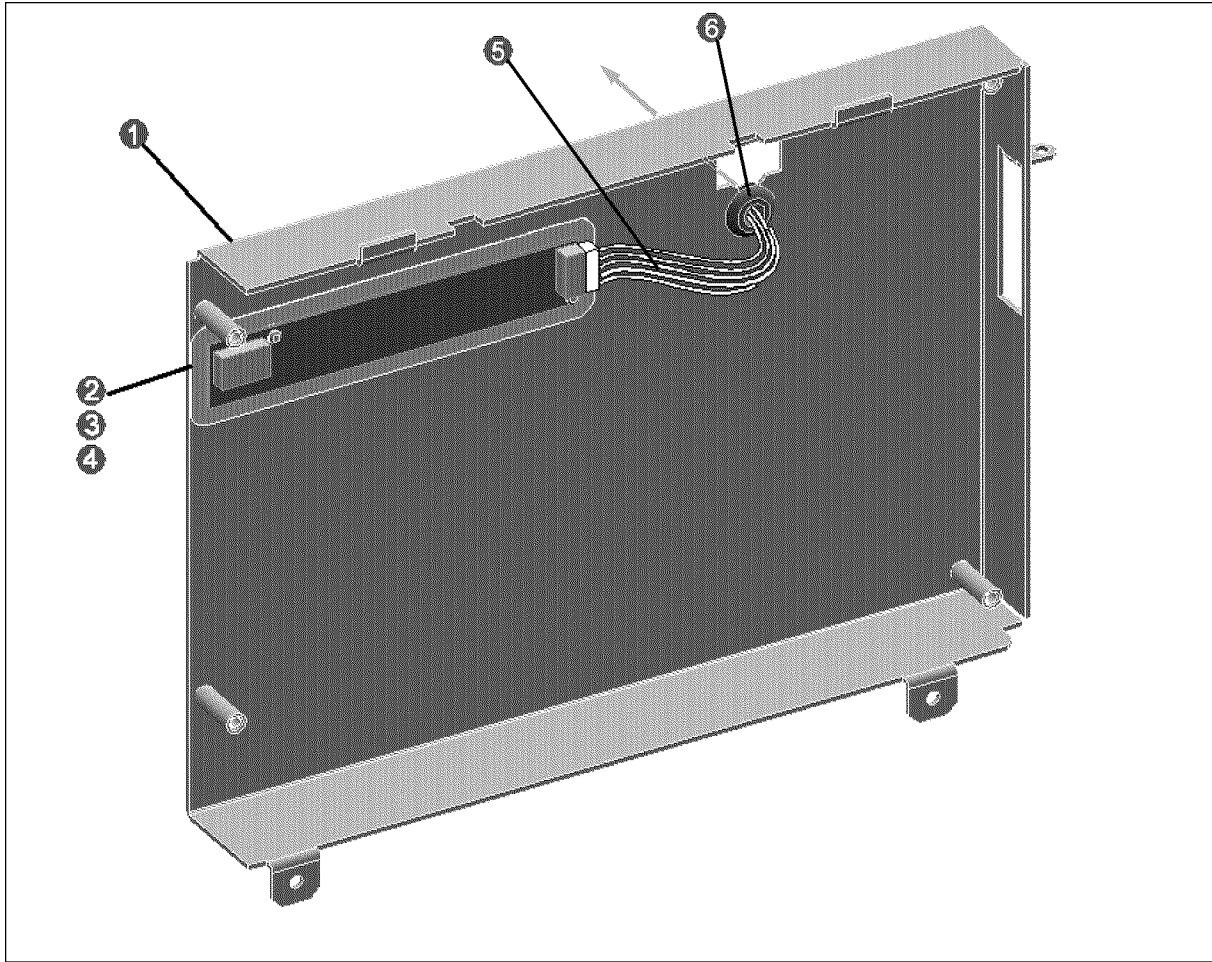

CDS11046

Figure 11-7. Front Assembly Parts 5

Table 11-9. Front Assembly Parts 5

Ref. Desig.	Agilent Part Number	C D	Qty.	Description	Mfr Code	Mfr Part Number
1	E4970-04002	3	1	Cover	28480	E4970-04002
2	E4970-25002	8	1	Insulator	28480	E4970-25002
3	0950-2924	6	1	A54 Inverter Board	28480	0950-2924
4	0515-0977	3	2	SCR-MACH M2X0.4	28480	0515-0977
5	04396-61709	5	1	Cable Assy	28480	04396-61709
6	0400-0010	2	1	Gromet	28480	0400-0010

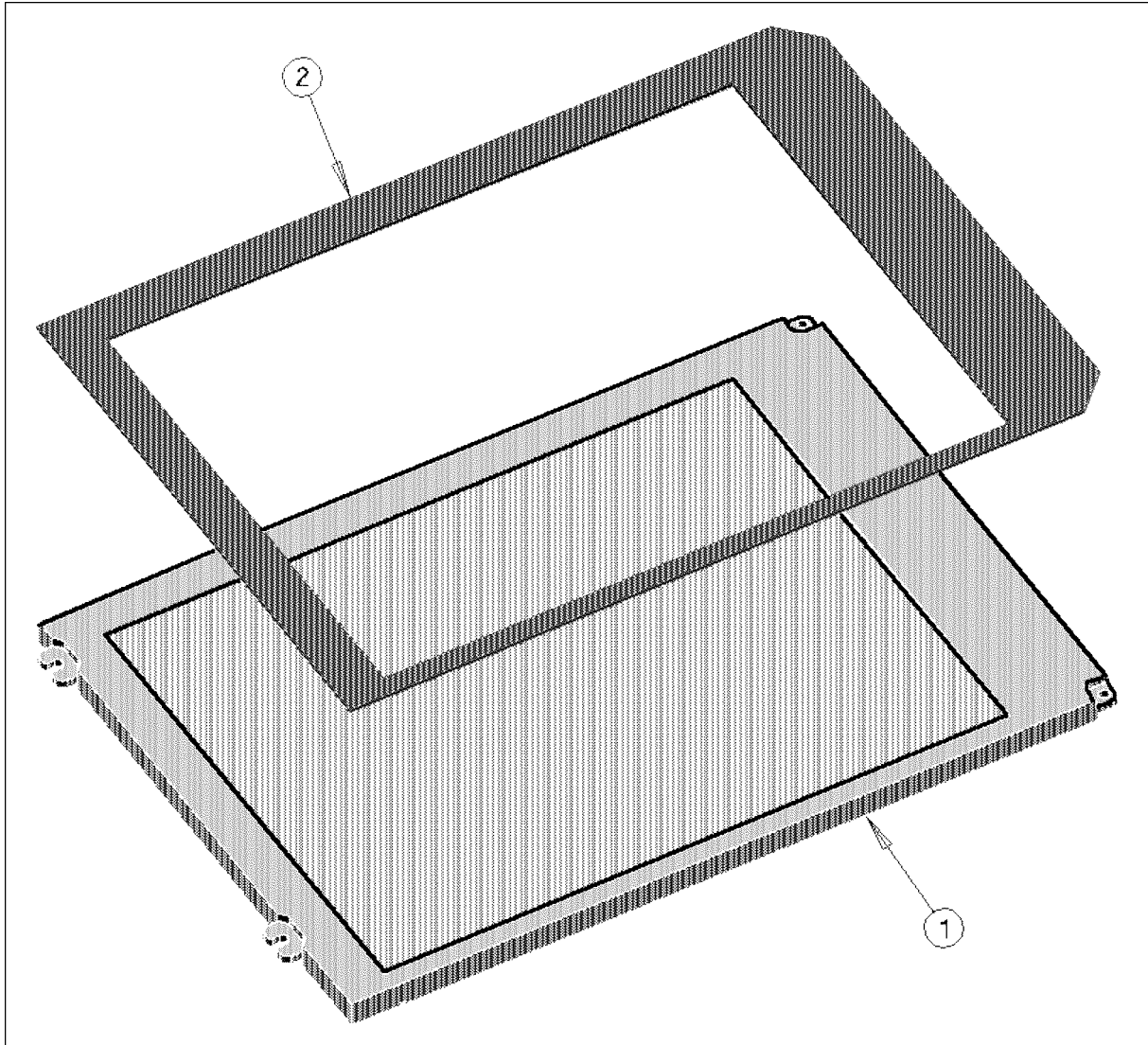

CDS11006

Figure 11-8. Front Assembly Parts 6

Table 11-10. Front Assembly Parts 6

Ref. Design.	Agilent Part Number	C D	Qty.	Description	Mfr Code	Mfr Part Number
1	2090-0574	7	1	A52 LCD	28480	2090-0574
2	04396-25071	8	1	Gasket	28480	04396-25071

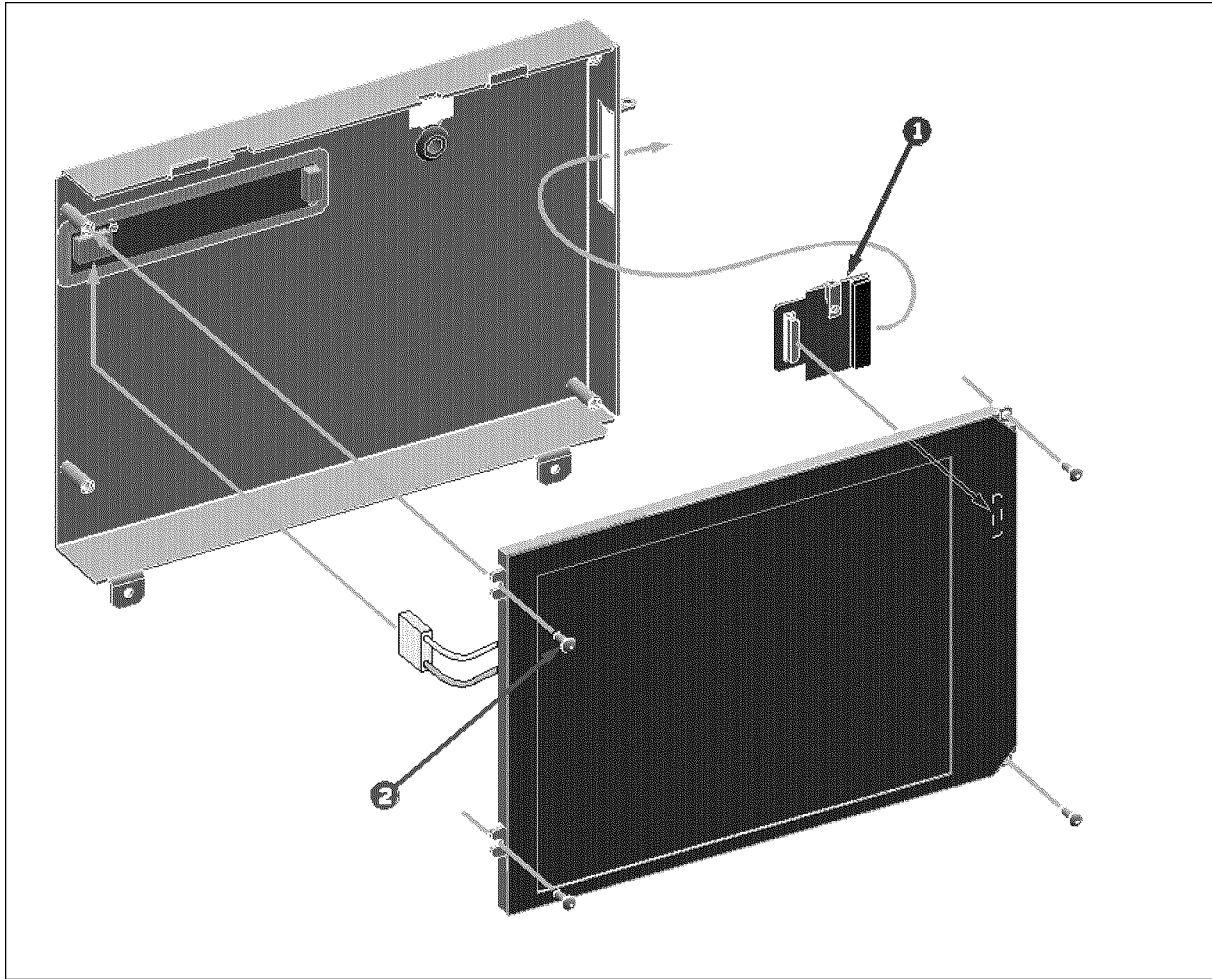

CDS11047

Figure 11-9. Front Assembly Parts 7

Table 11-11. Front Assembly Parts 7

Ref. Desig.	Agilent Part Number	C D	Qty.	Description	Mfr Code	Mfr Part Number
1	E4970-66539	2	1	LCD MINI-BD	28480	E4970-66539
2	0515-1550	0	4	SCR M3-L 8 P-H	28480	0515-1550

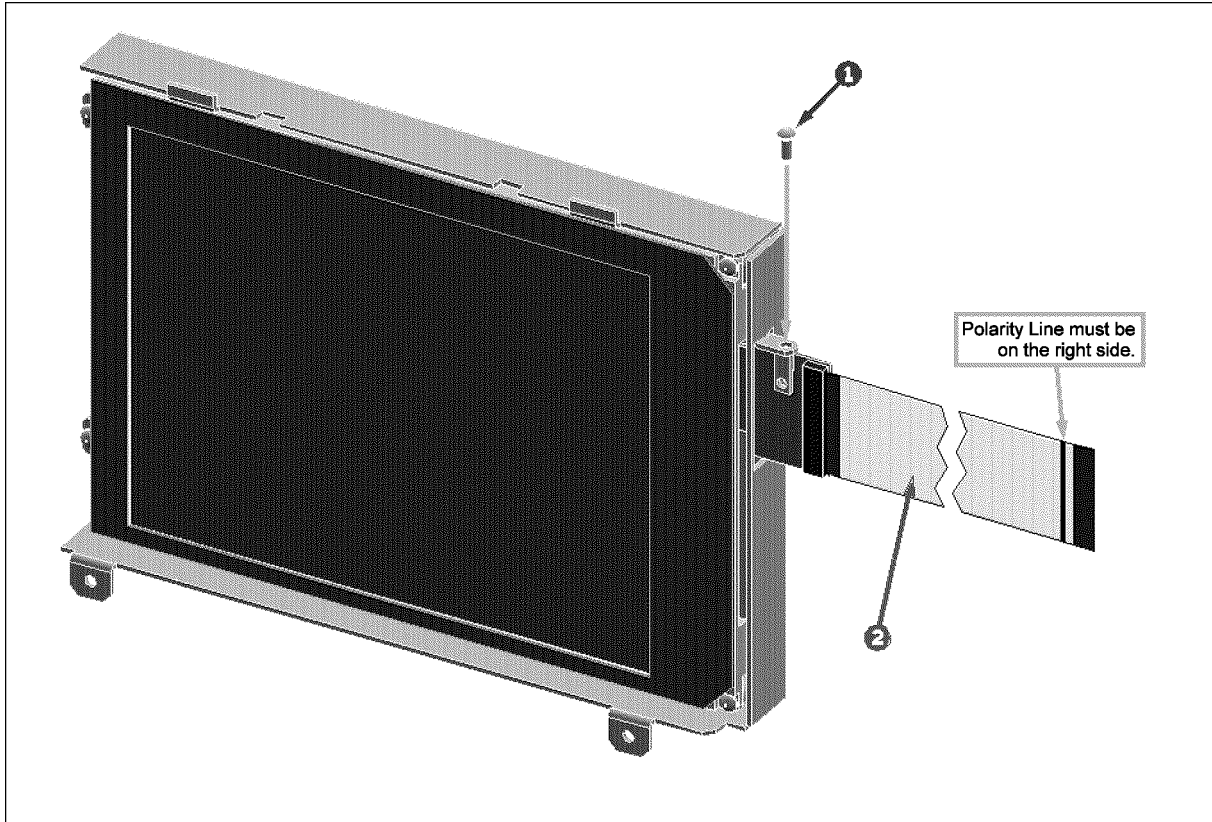

CDS11048

Figure 11-10. Front Assembly Parts 8

Table 11-12. Front Assembly Parts 8

Ref. Desig.	Agilent Part Number	C D	Qty.	Description	Mfr Code	Mfr Part Number
1	0515-1550	0	1	SCR M3-L 8 P-H	28480	0515-1550
2	E4970-61651	9	1	FLAT CBL FFC	28480	E4970-61651

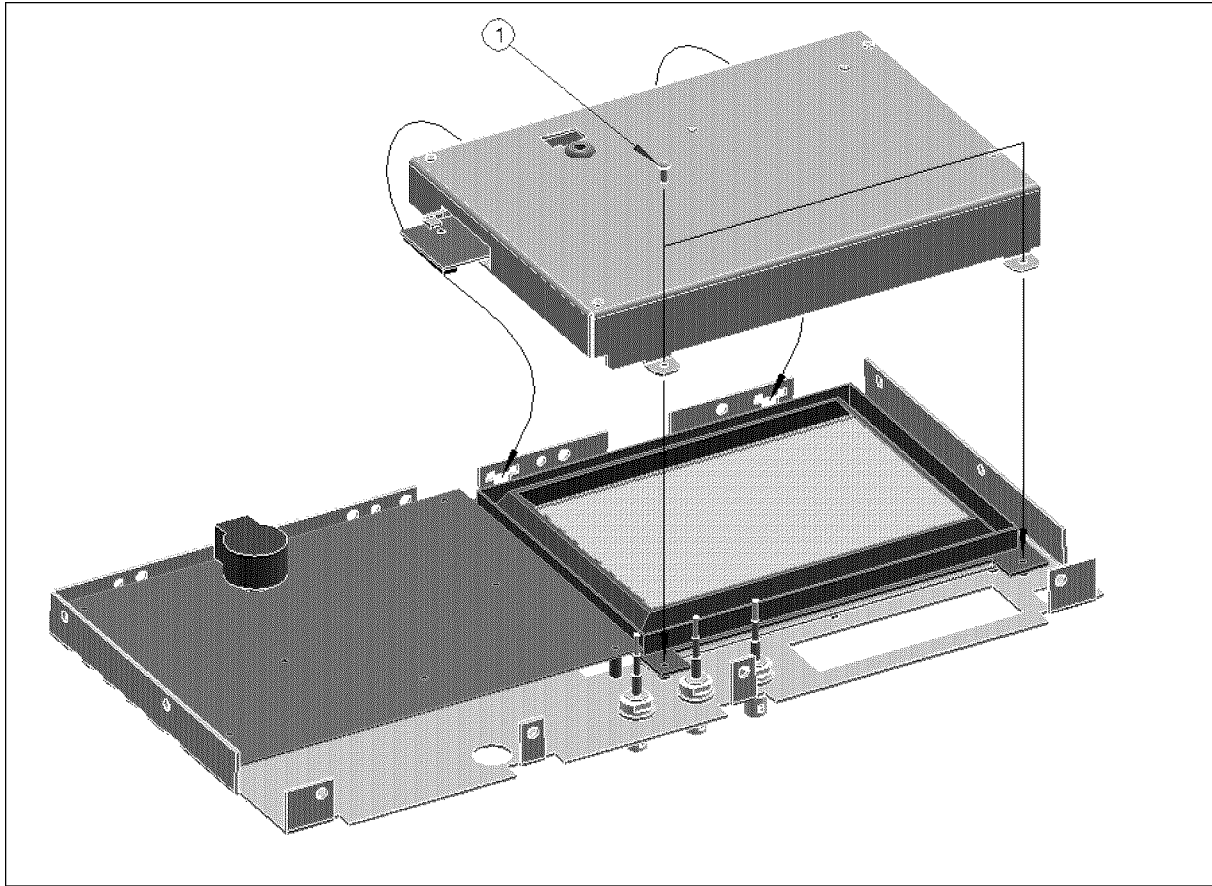

CDS11049

Figure 11-11. Front Assembly Parts 9

Table 11-13. Front Assembly Parts 9

Ref. Desig.	Agilent Part Number	C D	Qty.	Description	Mfr Code	Mfr Part Number
1	0515-1550	0	2	SCR M3-L 8 P-H	28480	0515-1550

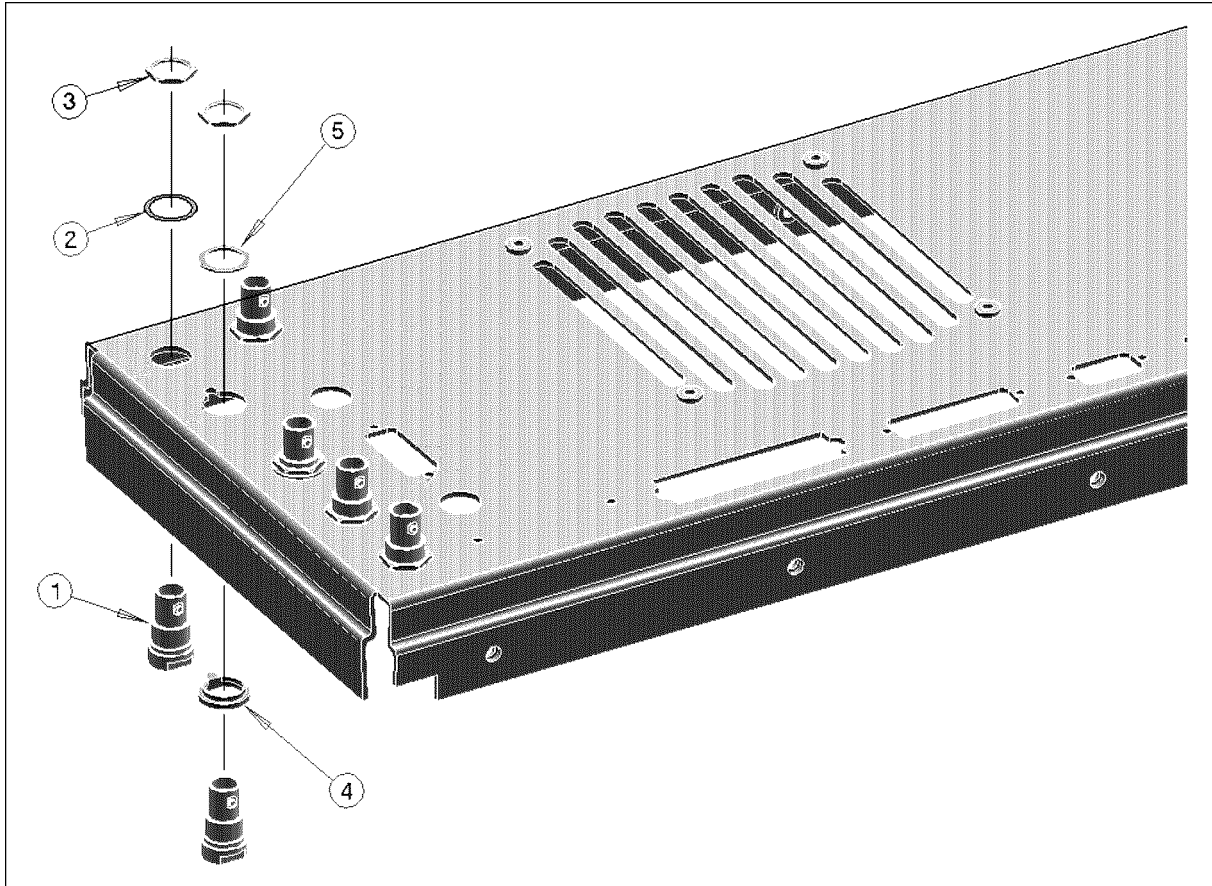

CDS11009

Figure 11-12. Rear Assembly Parts 1

Table 11-14. Rear Assembly Parts 1

Ref. Desig.	Agilent Part Number	C D	Qty.	Description	Mfr Code	Mfr Part Number
1	1250-0252	6	6	CONN-RF BNC	28480	1250-0252
2	2190-0102	8	4	WSHR-LK INTL T	28480	2190-0102
3	2950-0035	8	6	NUT-HEX-DBL-CHAM	28480	2950-0035
4	5040-3325	9	2	Insulator BNC	28480	5040-3325
5	5040-3324	8	2	Insulator BNC	28480	5040-3324

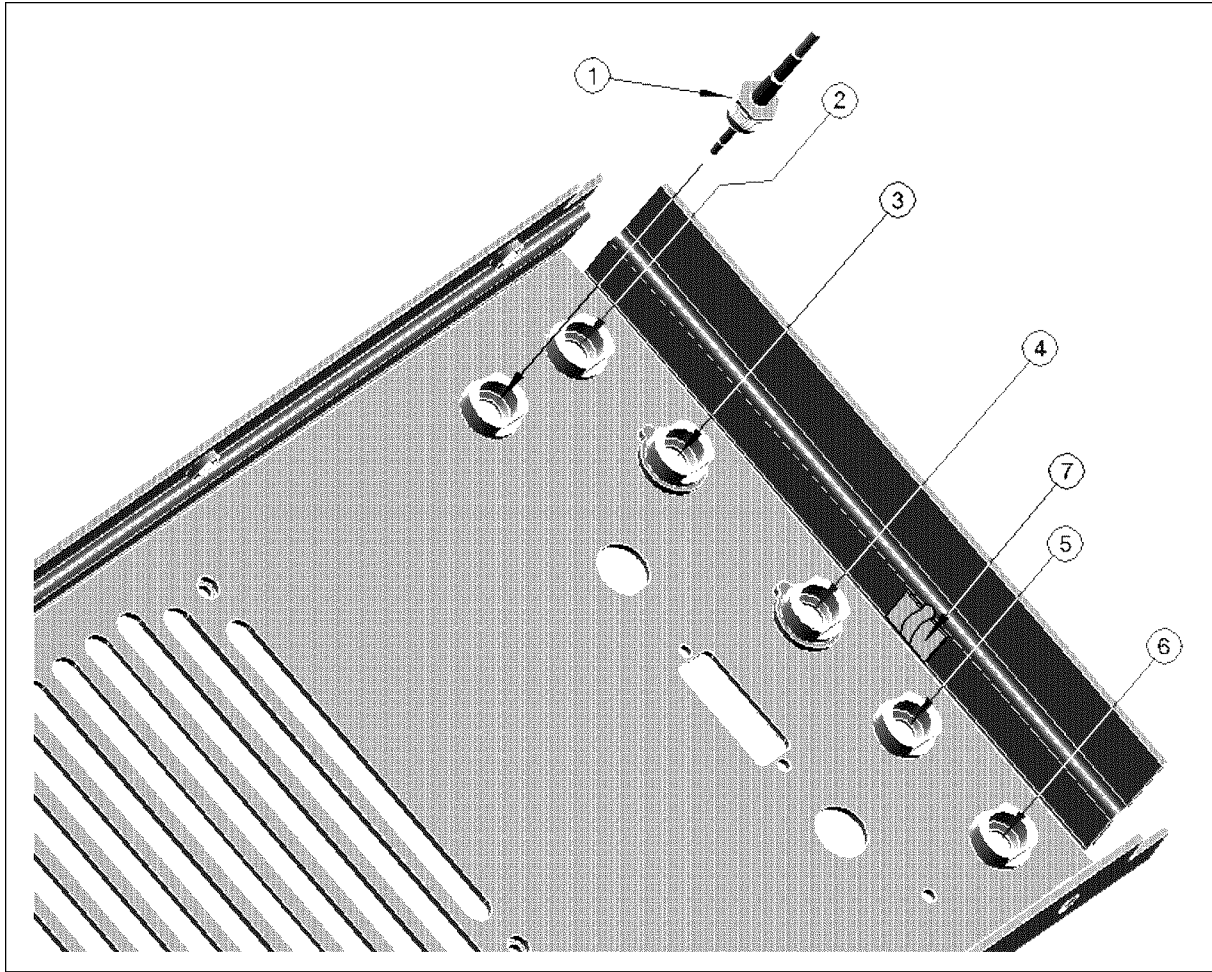

CDS11010

Figure 11-13. Rear Assembly Parts 2

Table 11-15. Rear Assembly Parts 2

Ref. Desig.	Agilent Part Number	C D	Qty.	Description	Mfr Code	Mfr Part Number
1	04396-61633	4	1	RF CBL ASSY	28480	04396-61633
2	04396-61634	5	1	RF CBL ASSY	28480	04396-61634
3	04352-61614	9	1	RF CBL ASSY	28480	04352-61614
4	04351-61622	8	1	RF CBL ASSY	28480	04351-61622
5	04352-61618	3	1	RF CBL ASSY	28480	04352-61618
6	04396-61635	6	1	RF CBL ASSY	28480	04396-61635
7	1400-1334	6	1	Clamp Cable	28480	1400-1334

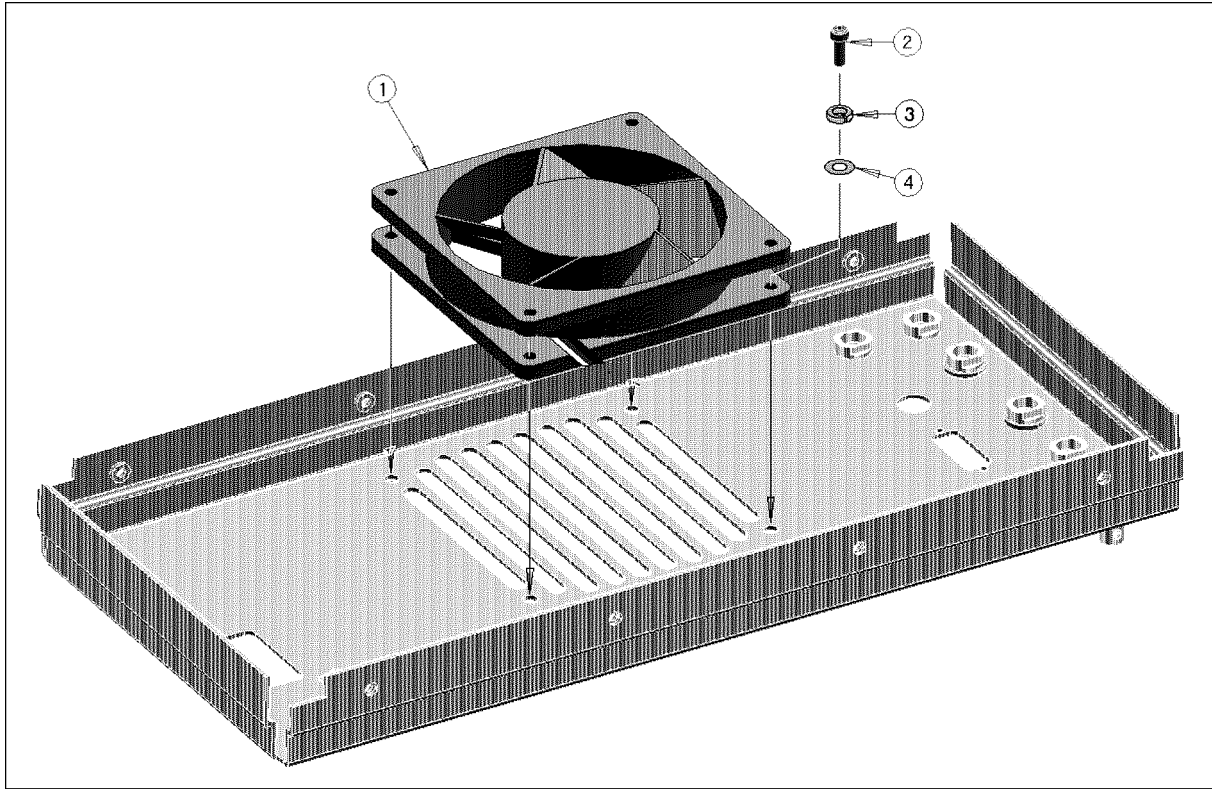

CDS11011

Figure 11-14. Rear Assembly Parts 3

Table 11-16. Rear Assembly Parts 3

Ref. Desig.	Agilent Part Number	C D	Qty.	Description	Mfr Code	Mfr Part Number
1	04396-61001	0	1	Fan ASSY	28480	04396-61001
2	0515-1598	6	4	SCR SKT-Head	28480	0515-1598
3	2190-0586	2	4	WSHR-LK HLCL	28480	2190-0586
4	3050-0893	9	4	WSHR-FL	28480	3050-0893

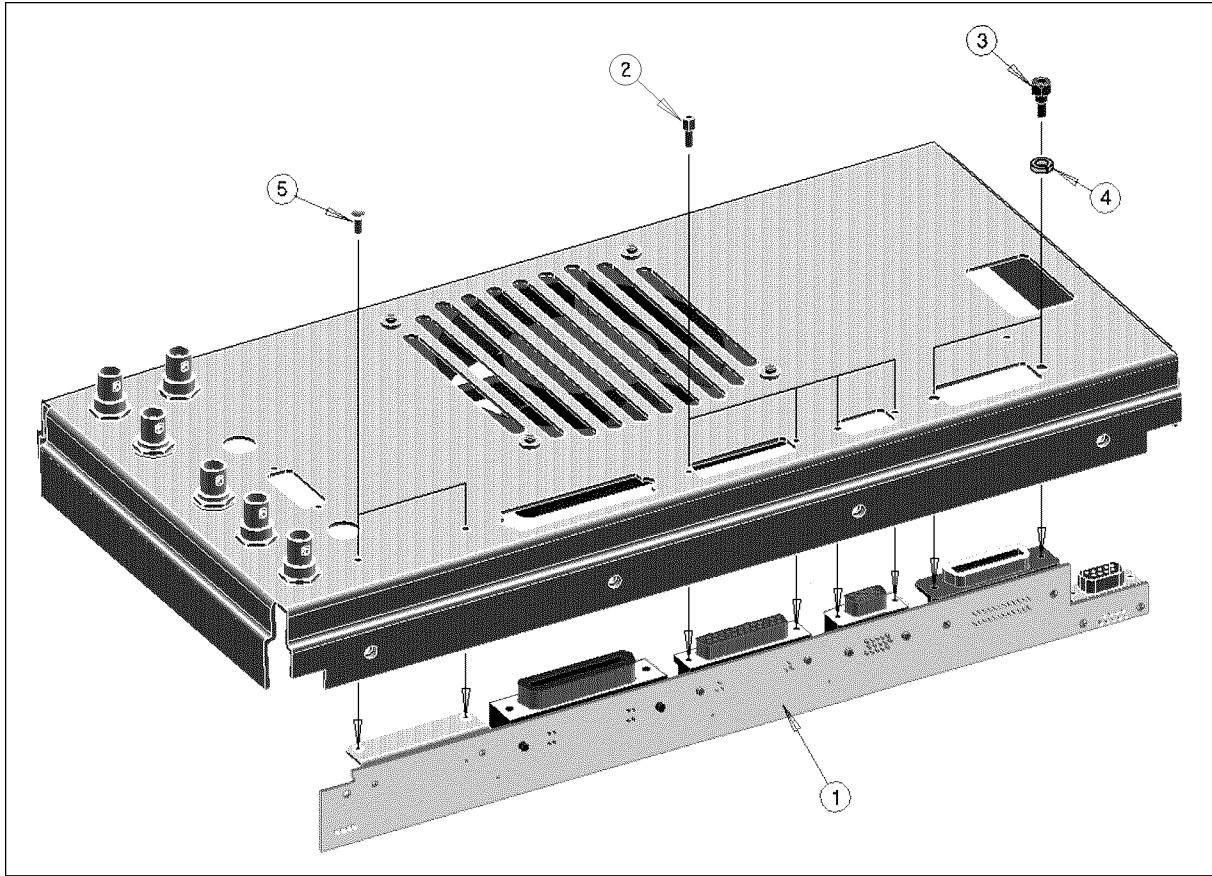

CDS11012

Figure 11-15. Rear Assembly Parts 4

Table 11-17. Rear Assembly Parts 4

Ref. Desig.	Agilent Part Number	C	D	Qty.	Description	Mfr Code	Mfr Part Number
1	E4970-66534	7		1	A31 Ext I/O Connector	28480	E4970-66534
2	1251-7812	0		4	Jackscrew	28480	1251-7812
3	0380-0644	4		2	STDF-HEX-M/FEM	28480	0380-0644
4	2190-0577	1		2	WSHR-LK HLCL	28480	2190-0577
5	0515-1550	0		2	SCR M3-L 8 P-H	28480	0515-1550

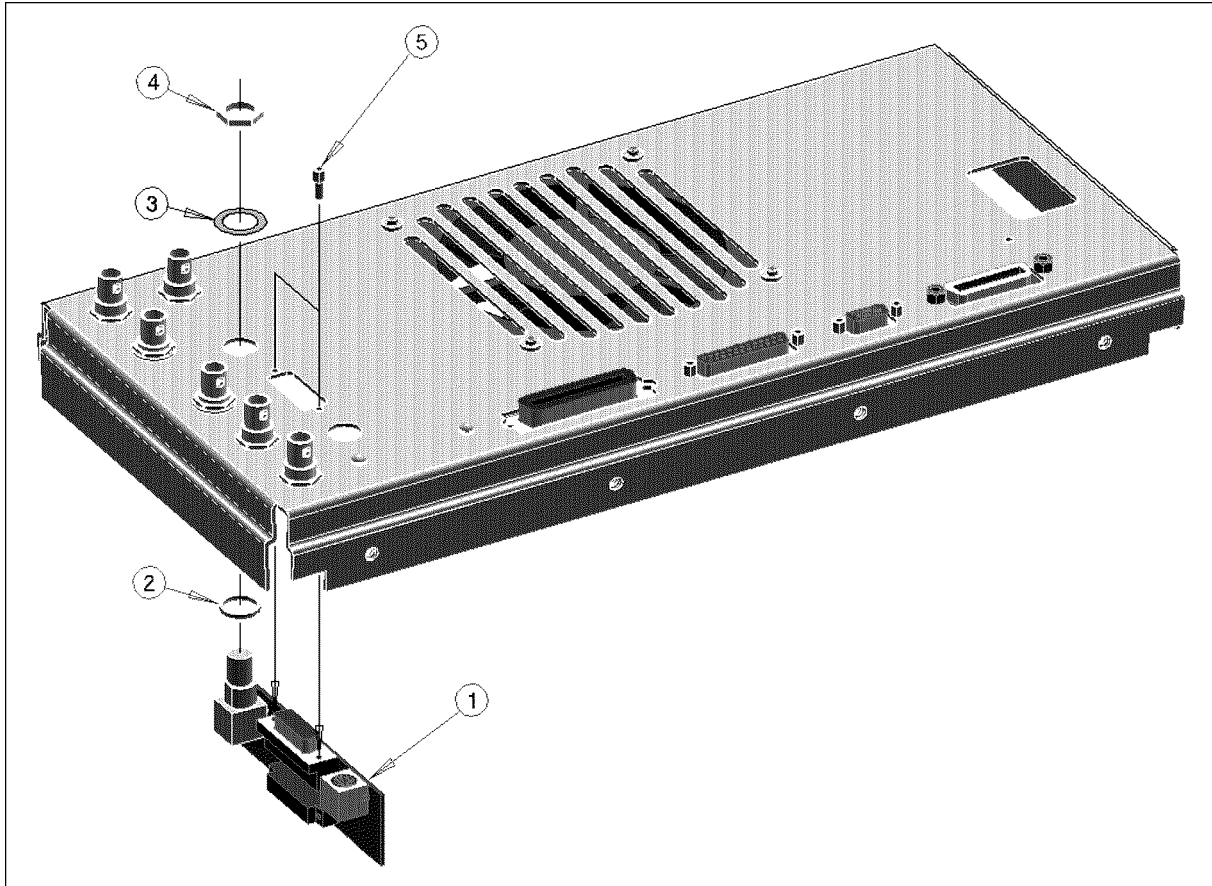

CDS11013

Figure 11-16. Rear Assembly Parts 5

Table 11-18. Rear Assembly Parts 5

Ref. Desig.	Agilent Part Number	C D	Qty.	Description	Mfr Code	Mfr Part Number
1	E4970-66532	5	1	A32 IBASIC I/F Board	28480	E4970-66532
2	3050-1546	1	1	Washer Flat NM	28480	3050-1546
3	2190-0054	9	1	WSHR-LK INTL T	28480	2190-0054
4	2950-0054	1	1	NUT-HEX-DBL-CHAM	28480	2950-0054
5	1251-7812	0	2	Jackscrew	28480	1251-7812

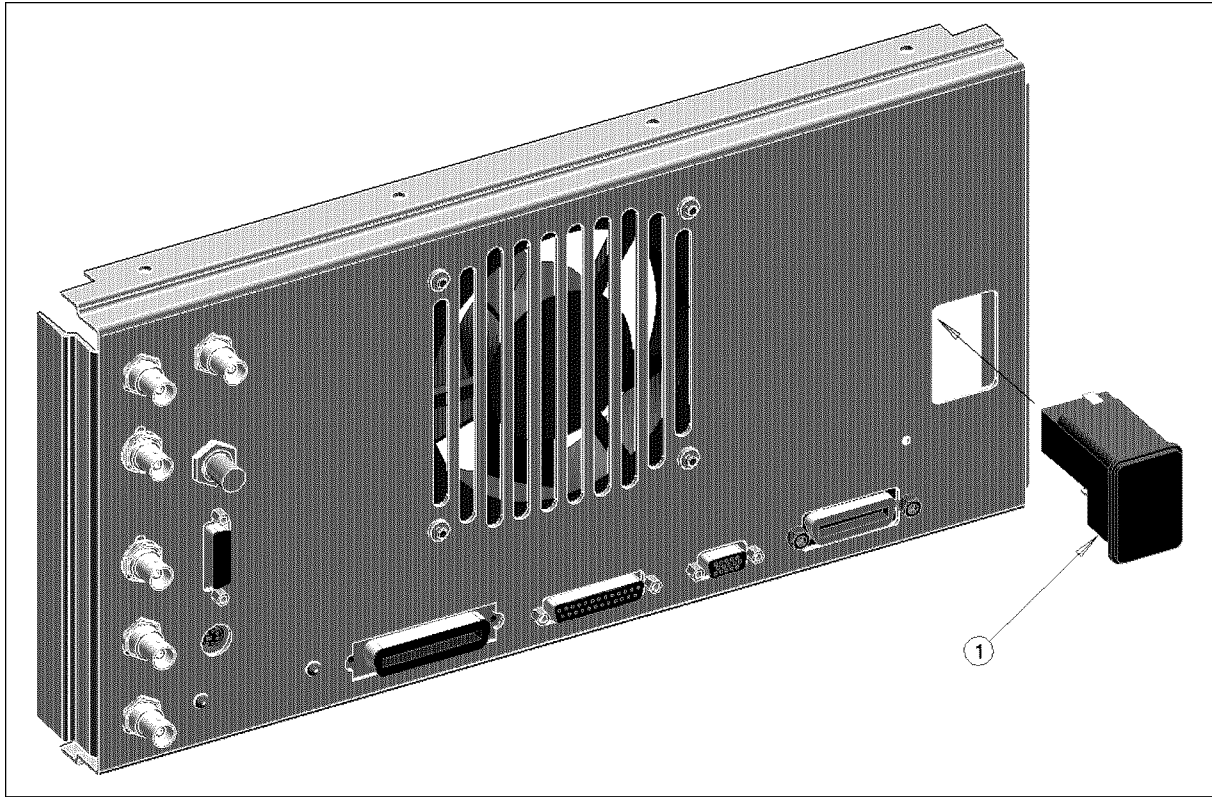

CDS11014

Figure 11-17. Rear Assembly Parts 6

Table 11-19. Rear Assembly Parts 6

Ref. Desig.	Agilent Part Number	C D	Qty.	Description	Mfr Code	Mfr Part Number
1	1252-6951	8	1	AC Inlet	28480	1252-6951
	2110-0030	3	1	Fuse 5A 250V	28480	2110-0030
	2110-1134	0	1	Fuse Drawer	28480	2110-1134

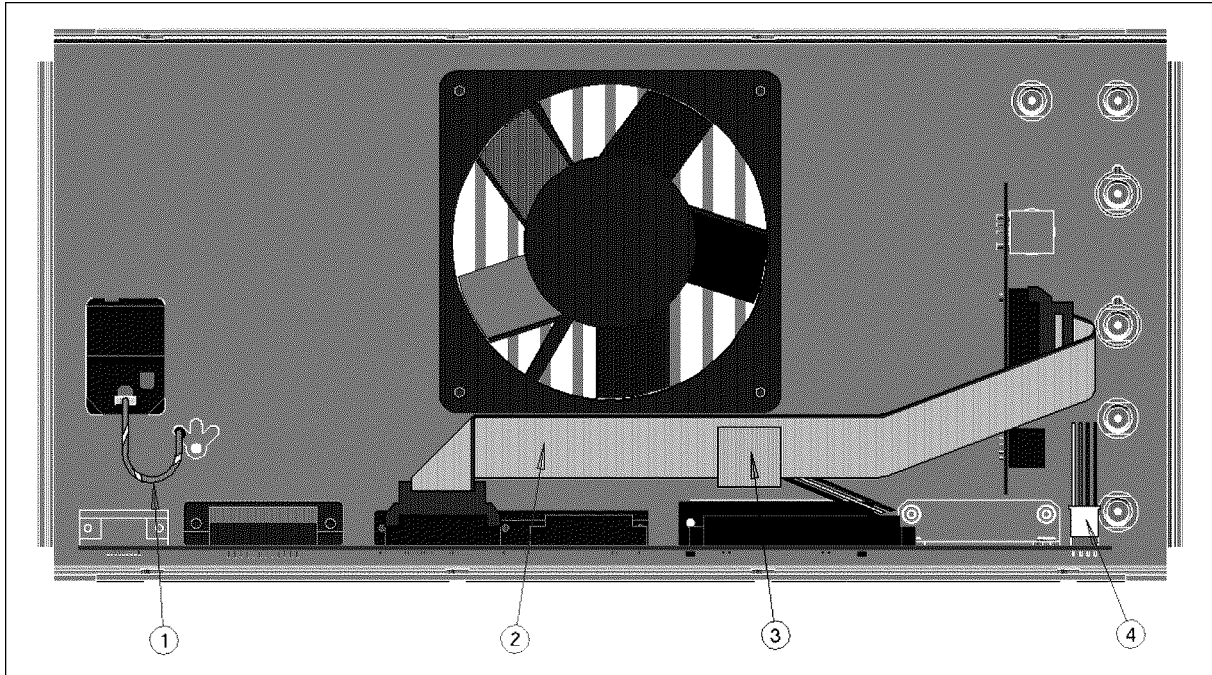

CDS11015

Figure 11-18. Rear Assembly Parts 7

Table 11-20. Rear Assembly Parts 7

Ref. Desig.	Agilent Part Number	C	D	Qty.	Description	Mfr Code	Mfr Part Number
1	E5100-61640	6		1	Wire ASSY GND	28480	E5100-61640
2	04396-61706	2		1	Cable ASSY	28480	04396-61706
3	1400-0611	0		1	Clamp-Cable	28480	1400-0611
4	04396-61682	3		1	Wire ASSY	28480	04396-61682

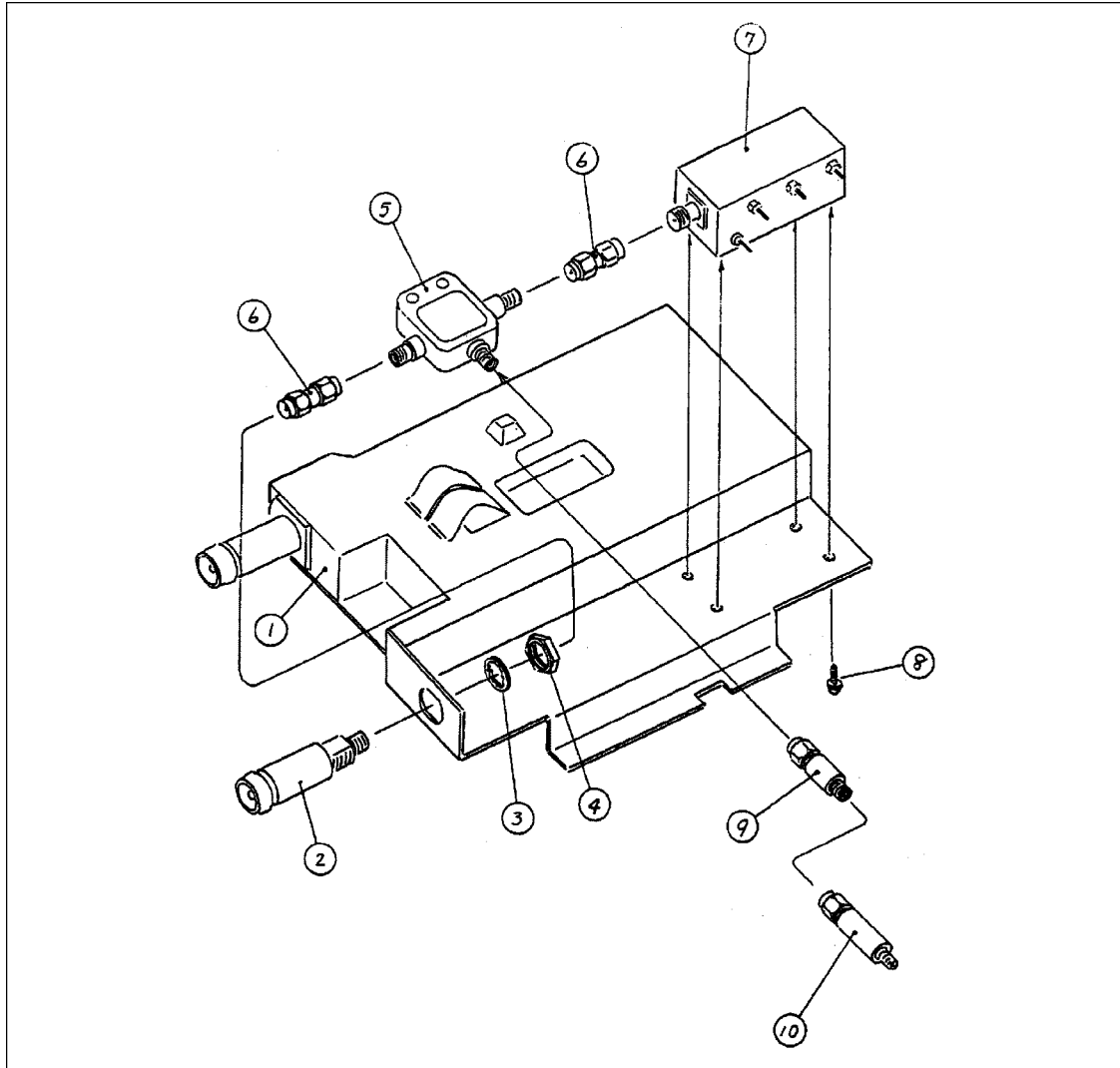

CDS11016

Figure 11-19. 1st Mixer Board - 1

Table 11-21. 1st Mixer Board - 1

Ref. Desig.	Agilent Part Number	C	D	Qty.	Description	Mfr Code	Mfr Part Number
1	04352-66516	4		1	A10 1st Mixer Board	28480	04352-66516
2	1250-2312	3		1	ADPT-RF N-SMA	28480	1250-2312
3	2190-0104	0		1	WSHR-LK INTL T	28480	2190-0104
4	2950-0132	6		1	NUT-HEX-DUB-CHAM	28480	2950-0132
5	11636B	1		1	A7 Power Divider	28480	11636B
6	1250-1159	4		2	ADPTR-COAX STR	28480	1250-1159
7	0955-1008	5		1	A8 Step ATT	28480	0955-1008
8	0515-1550	0		4	SCR M3-L 8 P-H	28480	0515-1550
9	0955-0971	9		1	ATT	28480	0955-0971
10	8471E#004	8		1	A9 Peak Detector	28480	8471E#004

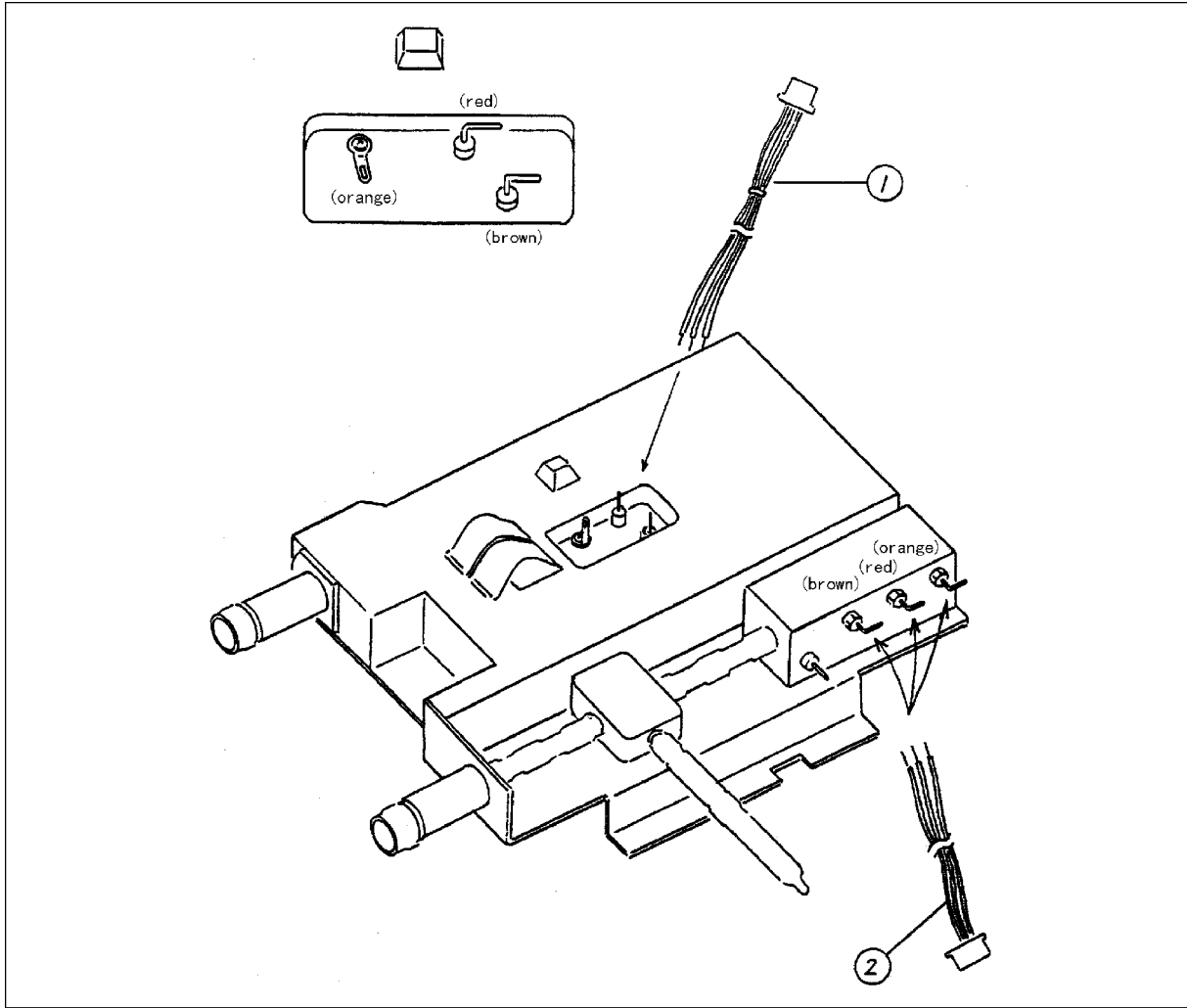

CDS11017

Figure 11-20. 1st Mixer Board -2

Table 11-22. 1st Mixer Board -2

Ref. Desig.	Agilent Part Number	C D	Qty.	Description	Mfr Code	Mfr Part Number
1	04352-61622	9	1	Cable ASSY	28480	04352-61622
2	04352-61623	0	1	Wire ASSY	28480	04352-61623

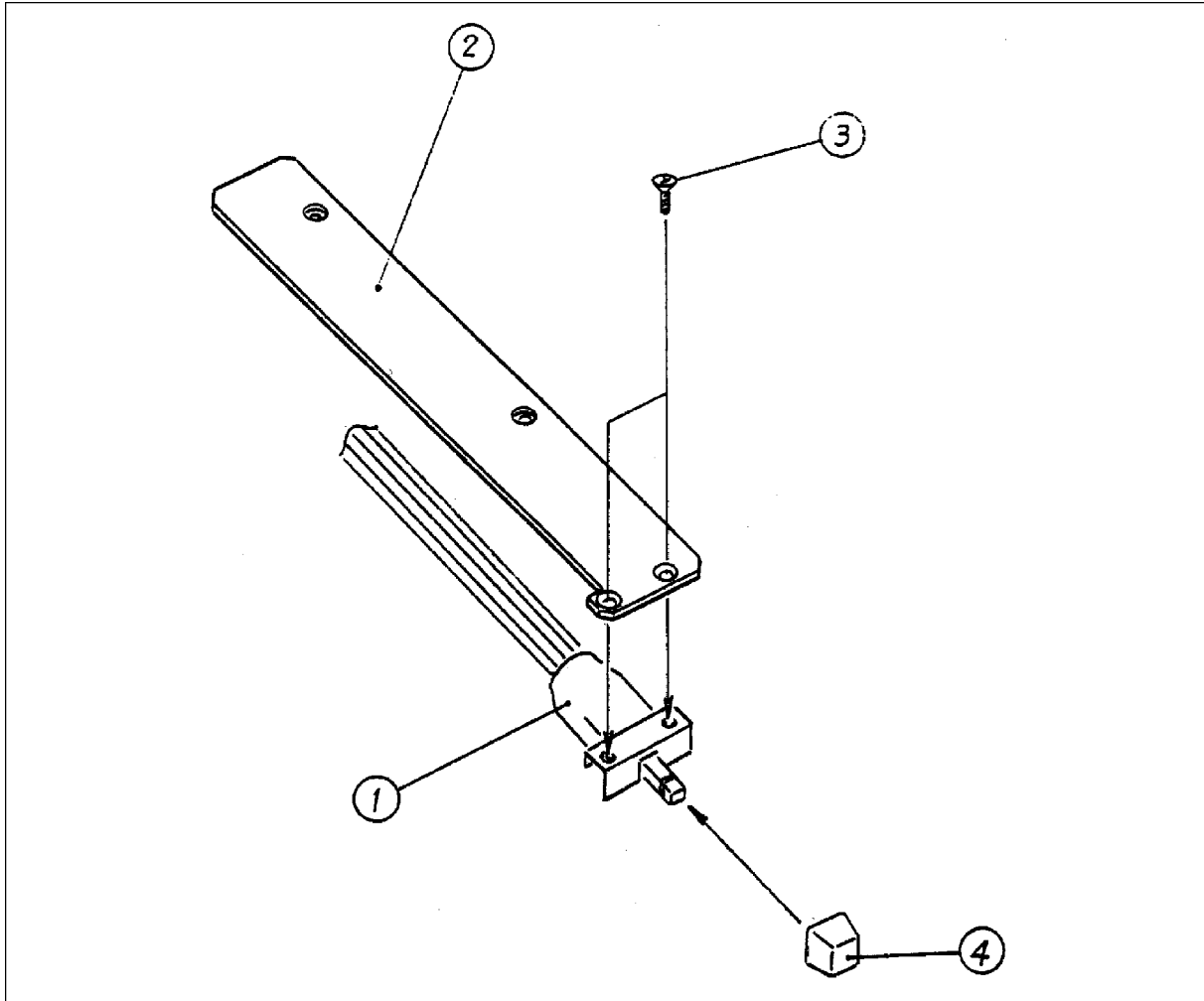

CDS11018

Figure 11-21. Power Switch ASSY

Table 11-23. Power Switch ASSY

Ref. Desig.	Agilent Part Number	C D	Qty.	Description	Mfr Code	Mfr Part Number
1	04396-61701	7	1	Cable ASSY	28480	04396-61701
2	04396-01274	3	1	Holder	28480	04396-01274
3	0515-0999	9	2	M2.5X0.45 L=6 FL	28480	0515-0999
4	5041-0564	4	1	KEY-Q-CORP WHT	28480	5041-0564

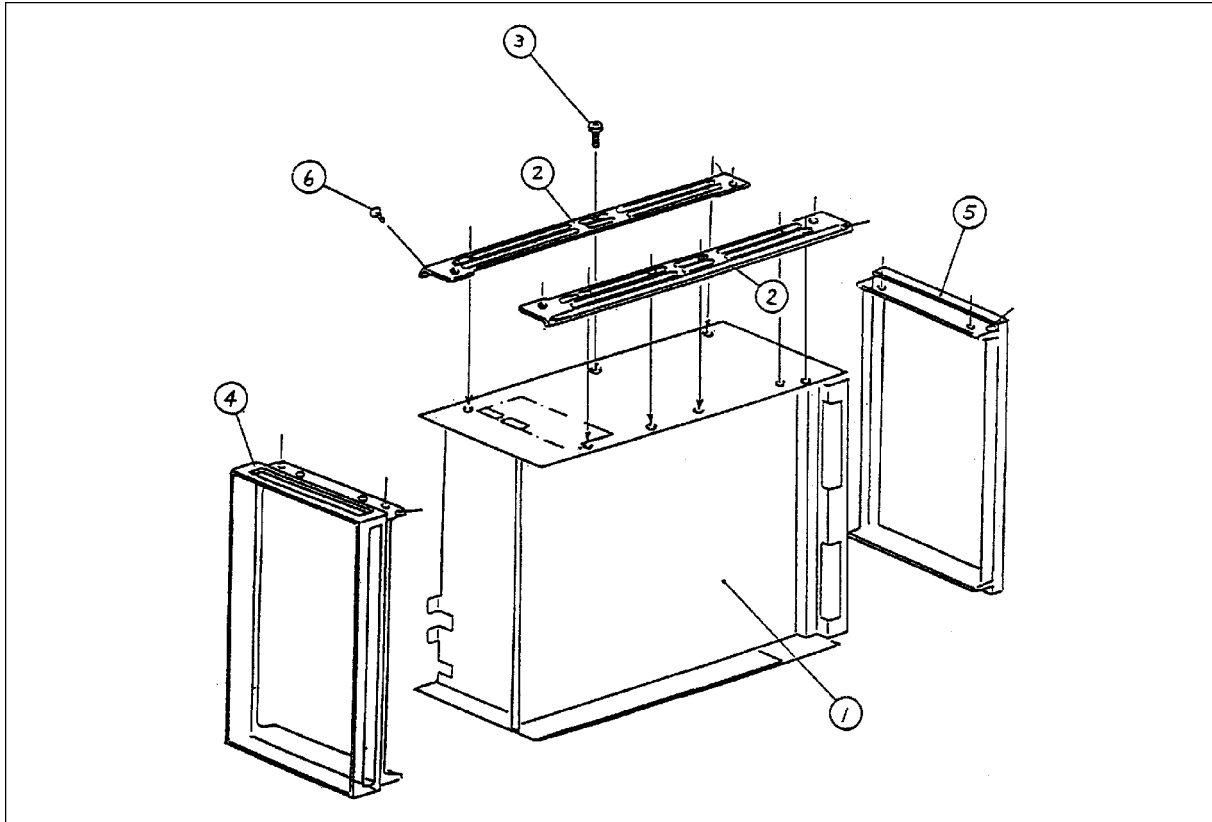

CDS11019

Figure 11-22. Chassis/Frames -1

Table 11-24. Chassis/Frames -1

Ref. Desig.	Agilent Part Number	C D	Qty.	Description	Mfr Code	Mfr Part Number
1	04396-60071	2	1	Chassis ASSY	28480	04396-60071
2	5021-5837	2	2	STRUT COR 497.8D	28480	5021-5837
3	0515-1719	3	8	SCR M4X10	28480	0515-1719
4	5022-1190	4	1	Front Frame221.5	28480	5022-1190
5	5021-5808	7	1	RR-FR 221.5XFM	28480	5021-5808
6	0515-1668	1	8	SCR-MTRC SPCLY	28480	0515-1668

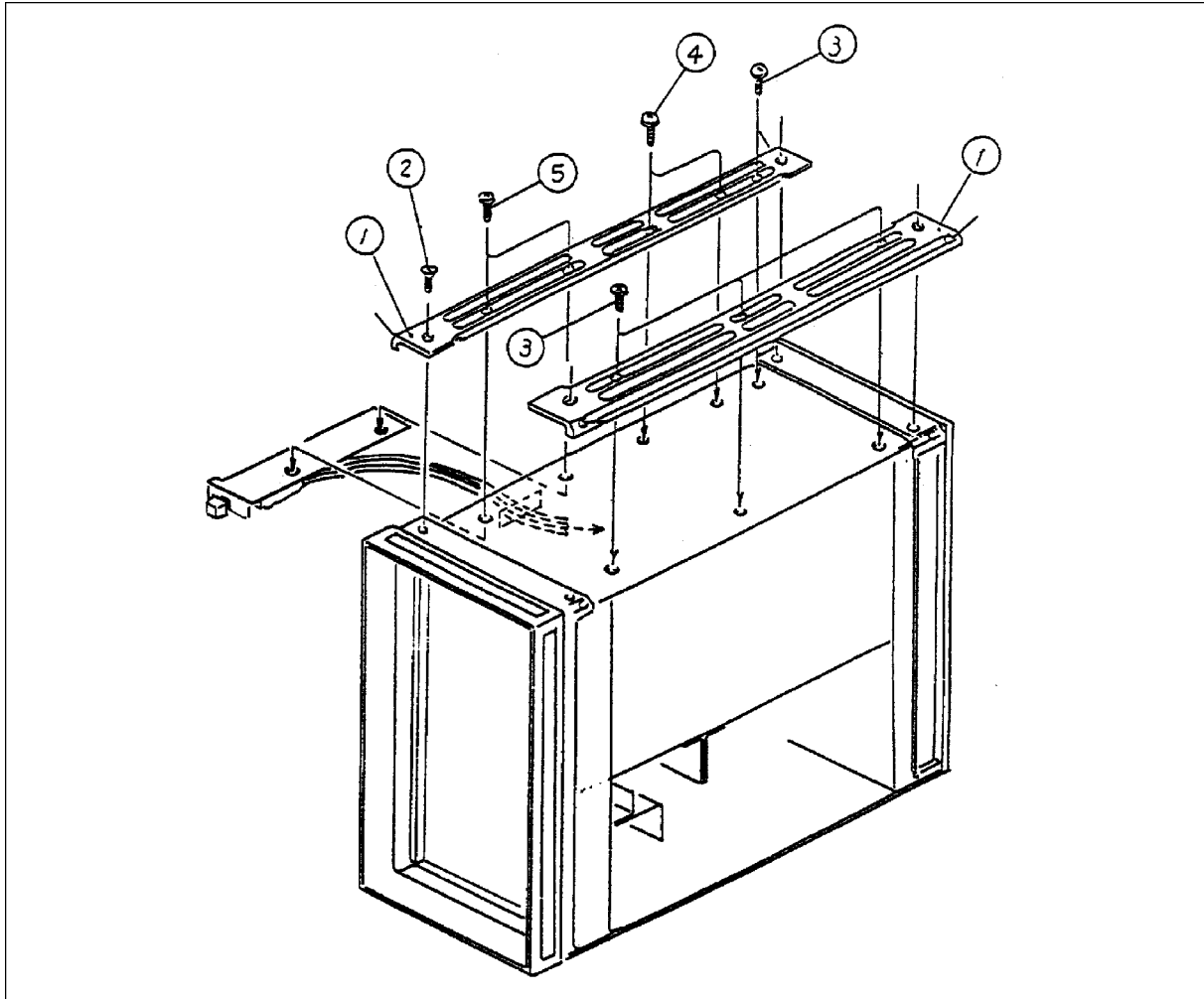

CDS11020

Figure 11-23. Chassis/Frames -2

Table 11-25. Chassis/Frames -2

Ref. Desig.	Agilent Part Number	C D	Qty.	Description	Mfr Code	Mfr Part Number
1	5021-5837	2	2	STRUT COR 497.8D	28480	5021-5837
2	0515-1668	1	8	SCR-MTRC SPCLY	28480	0515-1668
3	0515-2079	0	4	SCR M4X8	28480	0515-2079
4	0515-1718	2	2	SCR M4X12	28480	0515-1718
5	0515-0868	1	2	SCR M4X16	28480	0515-0868

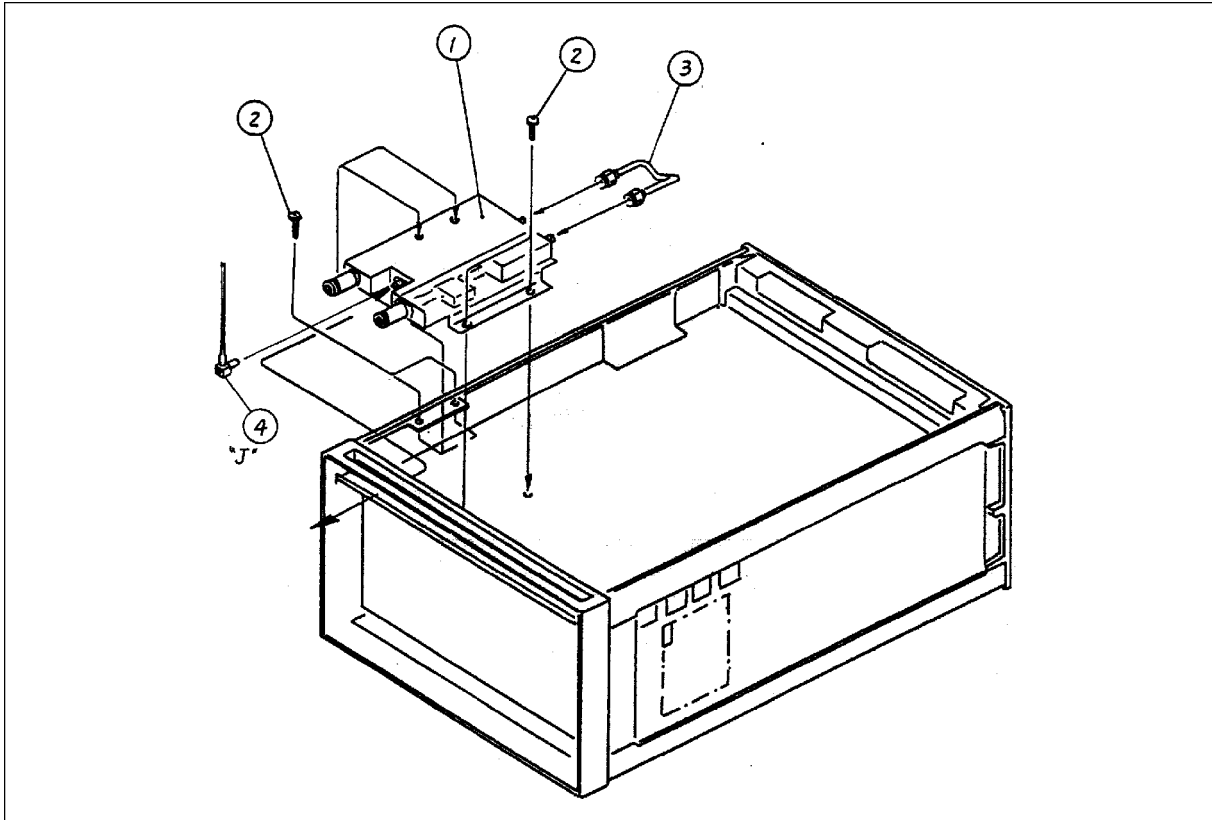

CDS11021

Figure 11-24. 1st Mixer Installation

Table 11-26. 1st Mixer Installation

Ref. Desig.	Agilent Part Number	C	D	Qty.	Description	Mfr Code	Mfr Part Number
1	see Figure 11-19						
2	0515-1550	0		4	SCR M3-L 8 P-H	28480	0515-1550
3	04352-61601	4		1	RF CBL ASSY SRGD	28480	04352-61601
3	04352-61612	7		1	RF CBL ASSY	28480	04352-61612

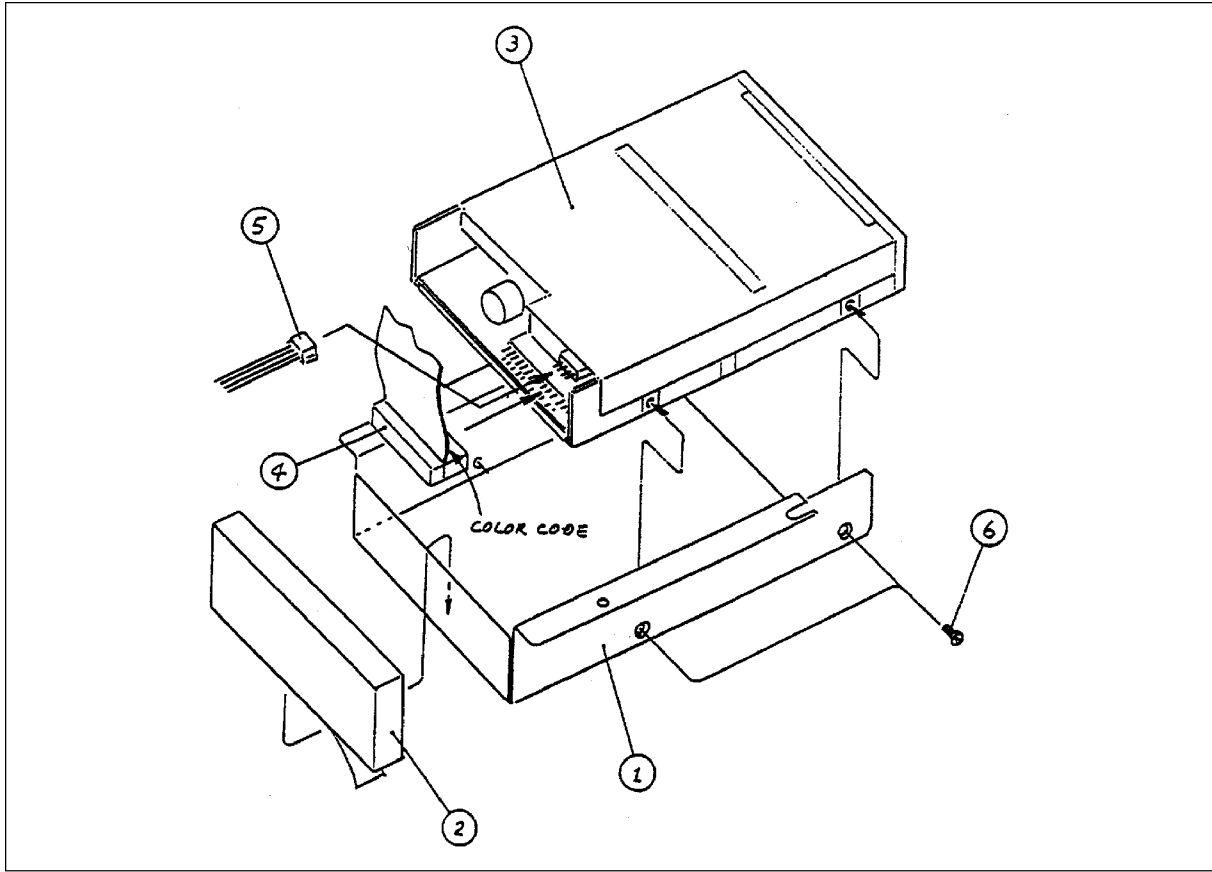

CDS11022

Figure 11-25. FDD Assembly

Table 11-27. FDD Assembly

Ref. Desig.	Agilent Part Number	C D	Qty.	Description	Mfr Code	Mfr Part Number
1	04396-01275	4	1	Angle	28480	04396-01275
2	04396-25004	7	1	Sponge	28480	04396-25004
3	0950-3208	0	1	A53 FDD	28480	0950-3208
4	04396-61651	6	1	Flat CBL ASSY	28480	04396-61651
5	04396-61672	1	1	Wire ASSY	28480	04396-61672
6	0515-0914	8	4	SCR-MACH M3X0.5	28480	0515-0914

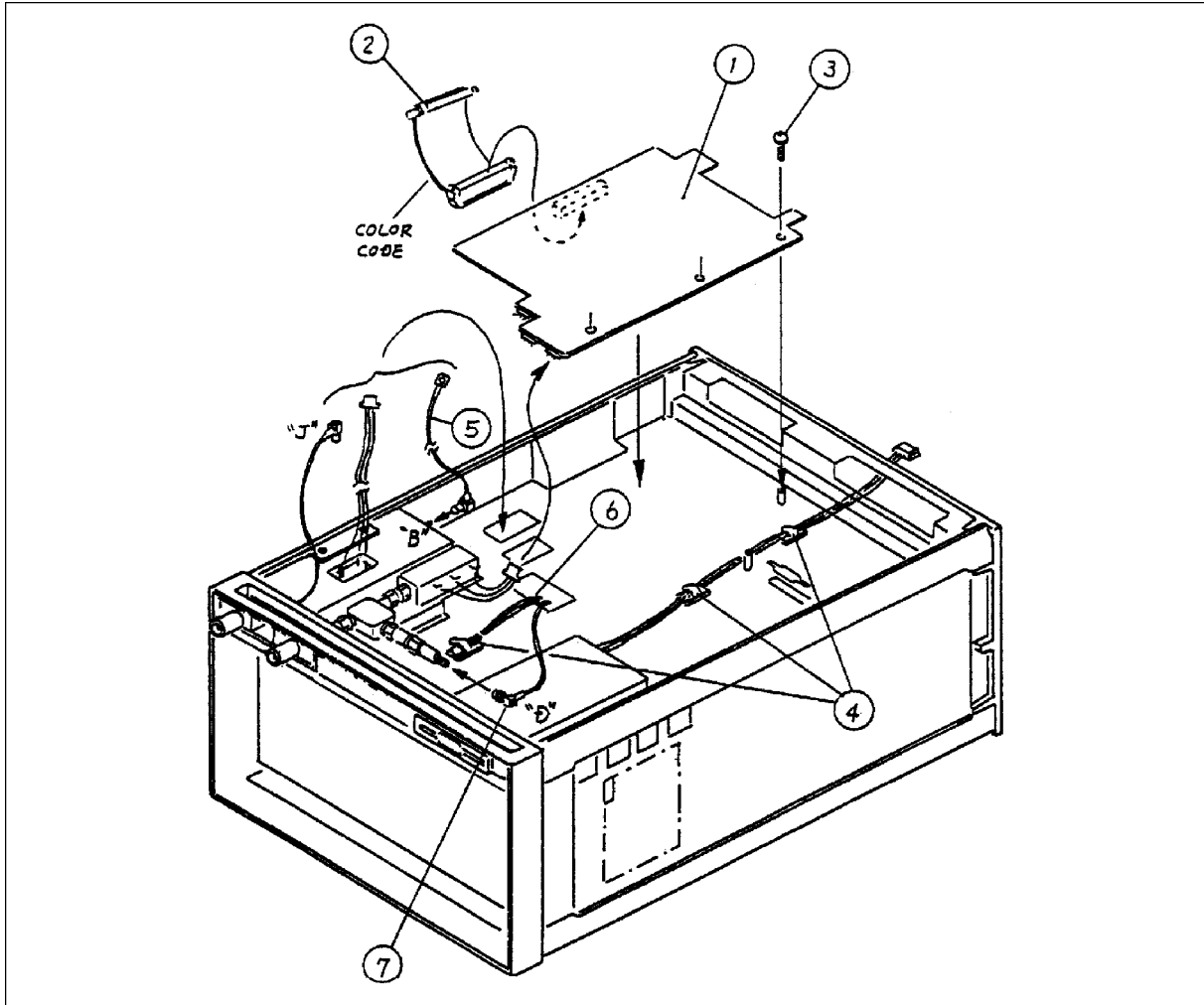

CDS11023

Figure 11-26. Motherboard Installation

Table 11-28. Motherboard Installation

Ref. Desig.	Agilent Part Number	C	D	Qty.	Description	Mfr Code	Mfr Part Number
1	04396-66520	8		1	A20 Motherboard	28480	04396-66520
2	04396-61661	8		1	CA-ASSY Flat 100	28480	04396-61661
3	0515-1550	0		14	SCR M3-L 8 P-H	28480	0515-1550
5	04352-61613	8		1	RF CBL ASSY	28480	04352-61613
6	04352-61621	8		1	Wire ASSY	28480	04352-61621
7	04352-61615	0		1	RF CBL ASSY	28480	04352-61615

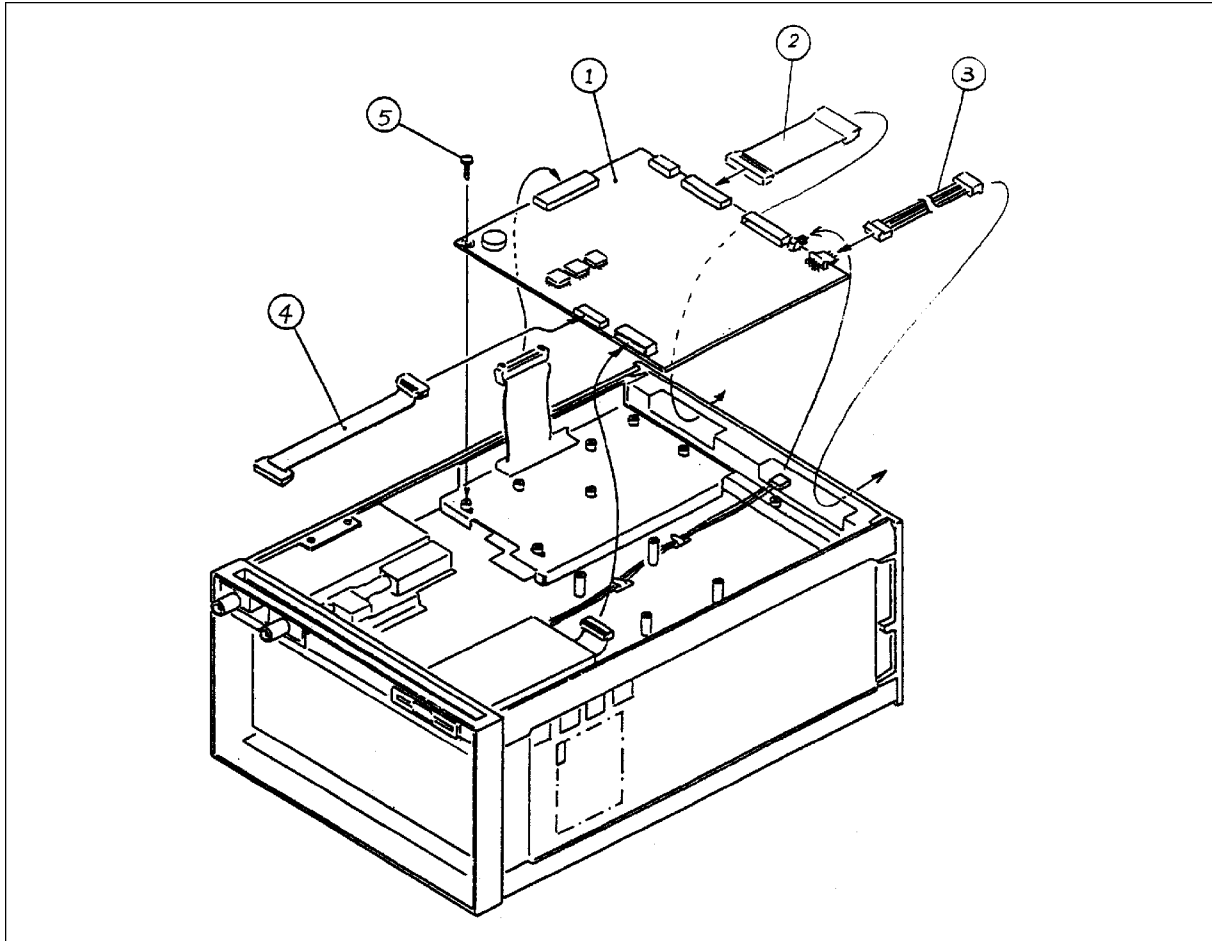

CDS11024

Figure 11-27. CPU Board Installation

Table 11-29. CPU Board Installation

Ref. Desig.	Agilent Part Number	C	D	Qty.	Description	Mfr Code	Mfr Part Number
1	E4970-66501	5		1	A1 CPU Board	28480	E4970-66501
2	04396-61661	8		1	CA-ASSY Flat 100	28480	04396-61661
3	04396-61671	0		1	Wire ASSY	28480	04396-61671
4	04396-61662	9		1	CA-ASSY Flat 40	28480	04396-61662
5	0515-1550	0		13	SCR M3-L 8 P-H	28480	0515-1550

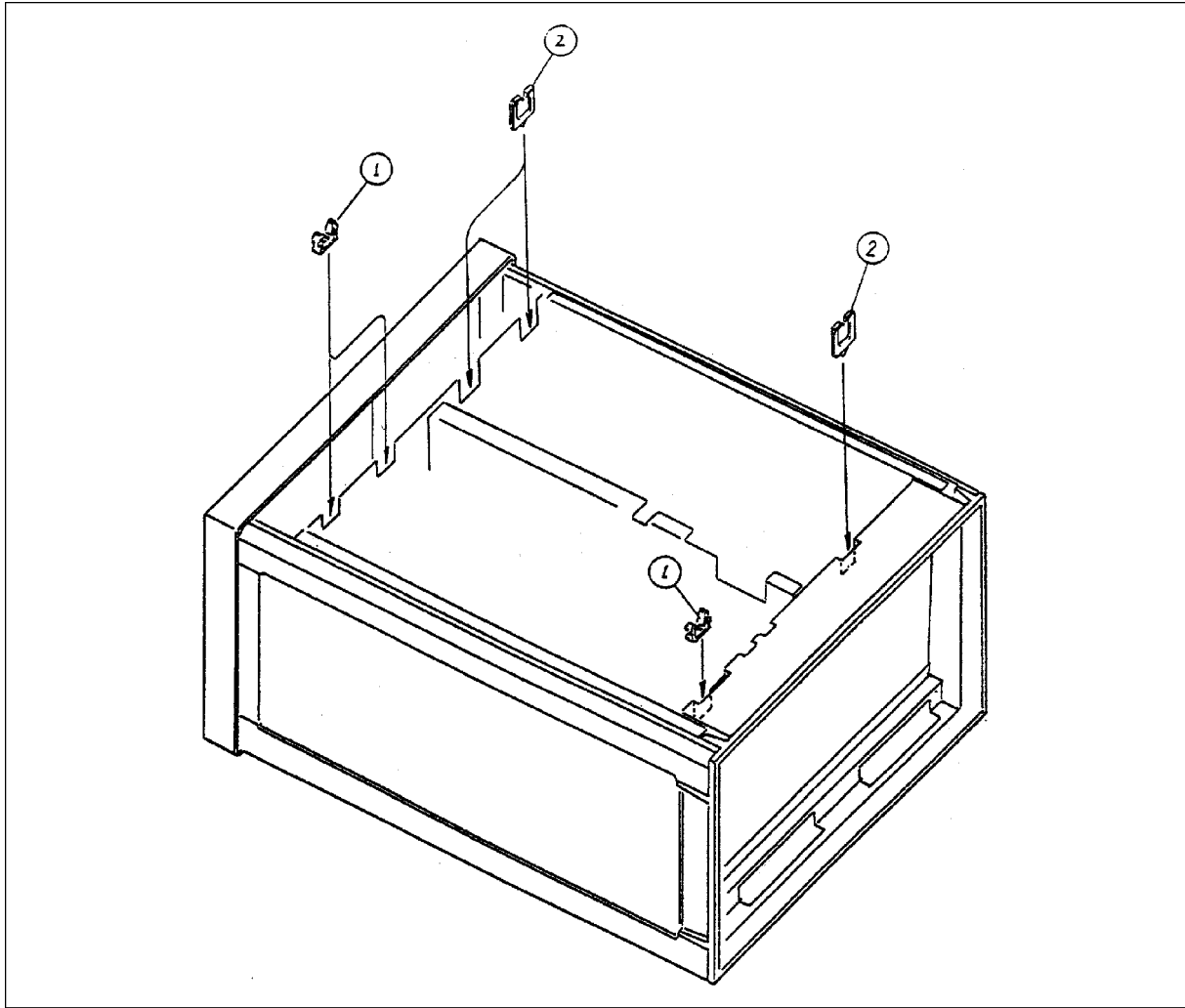

CDS11025

Figure 11-28. Saddle Edge

Table 11-30. Saddle Edge

Ref. Desig.	Agilent Part Number	C D	Qty.	Description	Mfr Code	Mfr Part Number
1	1400-1048	9	3	Saddle-Edge	28480	1400-1048
2	1400-2198	2	3	Saddle-Edge	28480	1400-2198

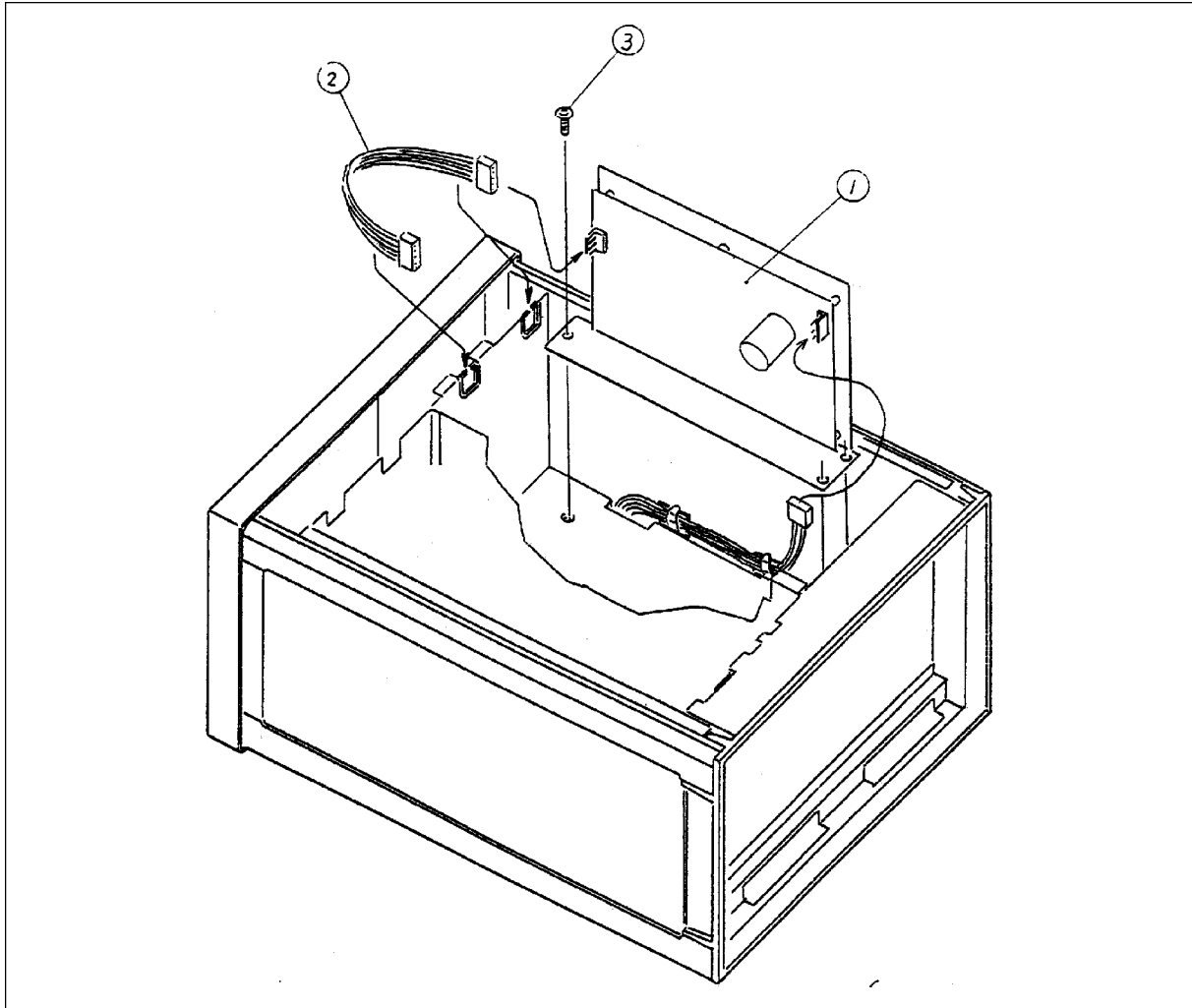

CDS11026

Figure 11-29. Prerregulator Installation

Table 11-31. Prerregulator Installation

Ref. Desig.	Agilent Part Number	C D	Qty.	Description	Mfr Code	Mfr Part Number
1	0950-3246	7	1	A40 Prerregulator	28480	0950-3246
2	04396-61671	0	1	Wire ASSY	28480	04396-61671
3	0515-1719	3	3	SCR M4X10	28480	0515-1719

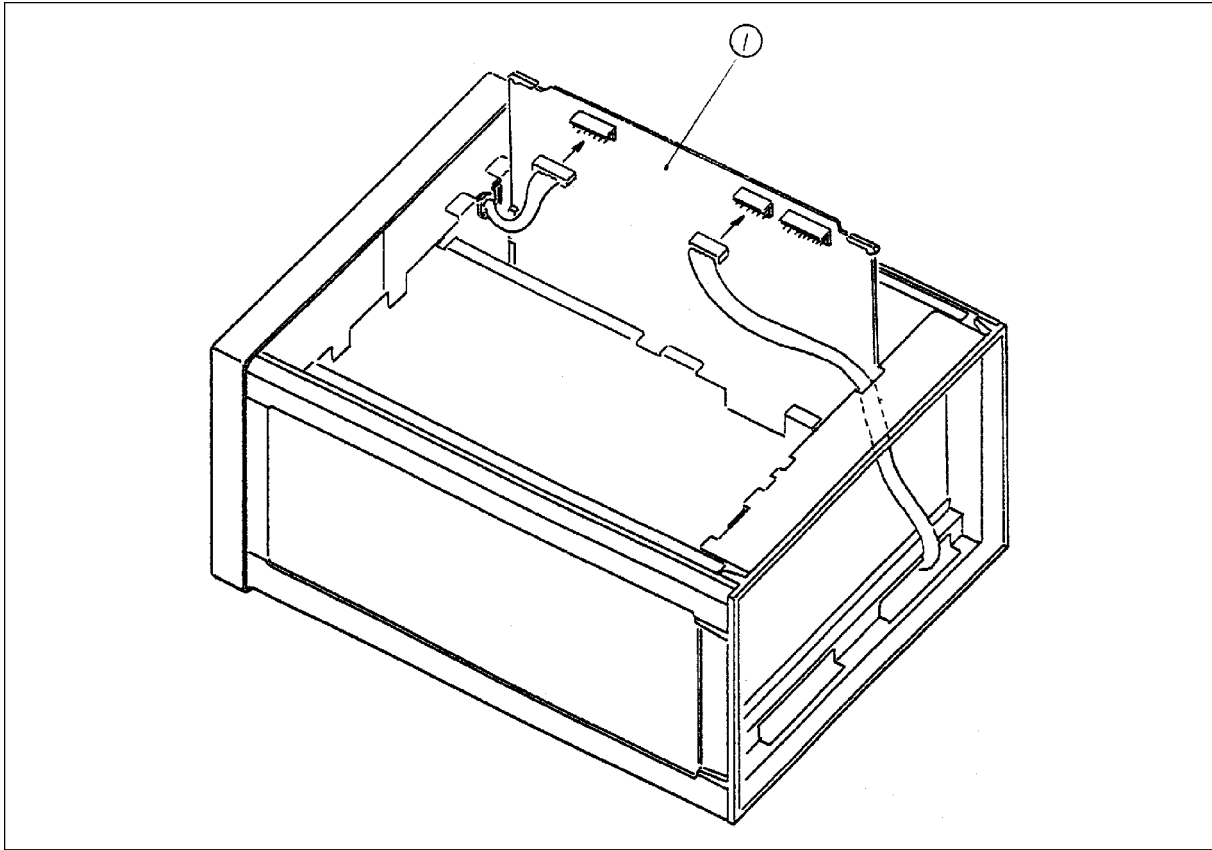

CDS11027

Figure 11-30. DC-DC Converter Installation

Table 11-32. DC-DC Converter Installation

Ref. Desig.	Agilent Part Number	C D	Qty.	Description	Mfr Code	Mfr Part Number
1	E4970-66550	3	1	A50 DC-DC Converter	28480	E4970-66550

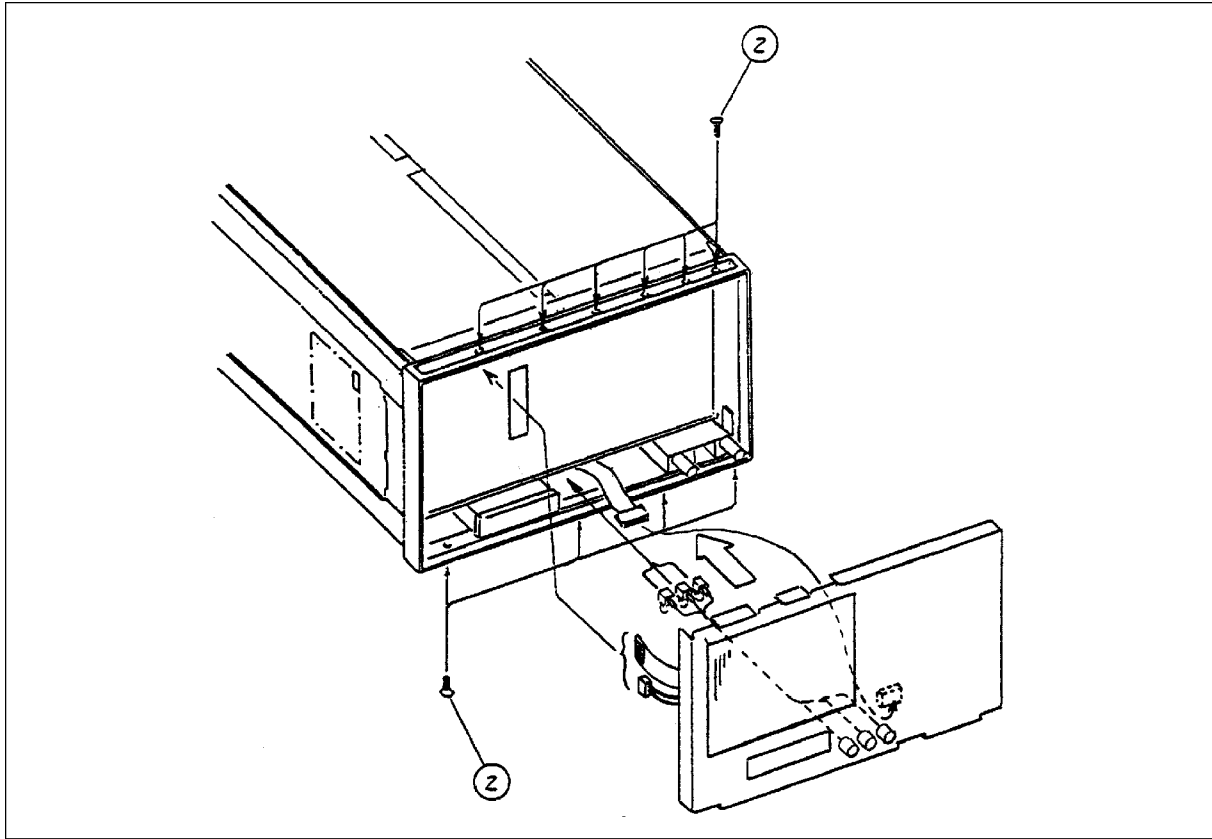

CDS11028

Figure 11-31. Front Panel Installation

Table 11-33. Front Panel Installation

Ref. Desig.	Agilent Part Number	C D	Qty.	Description	Mfr Code	Mfr Part Number
2	0515-0889	6	10	SCR-MACH M3.5X.6	28480	0515-0889

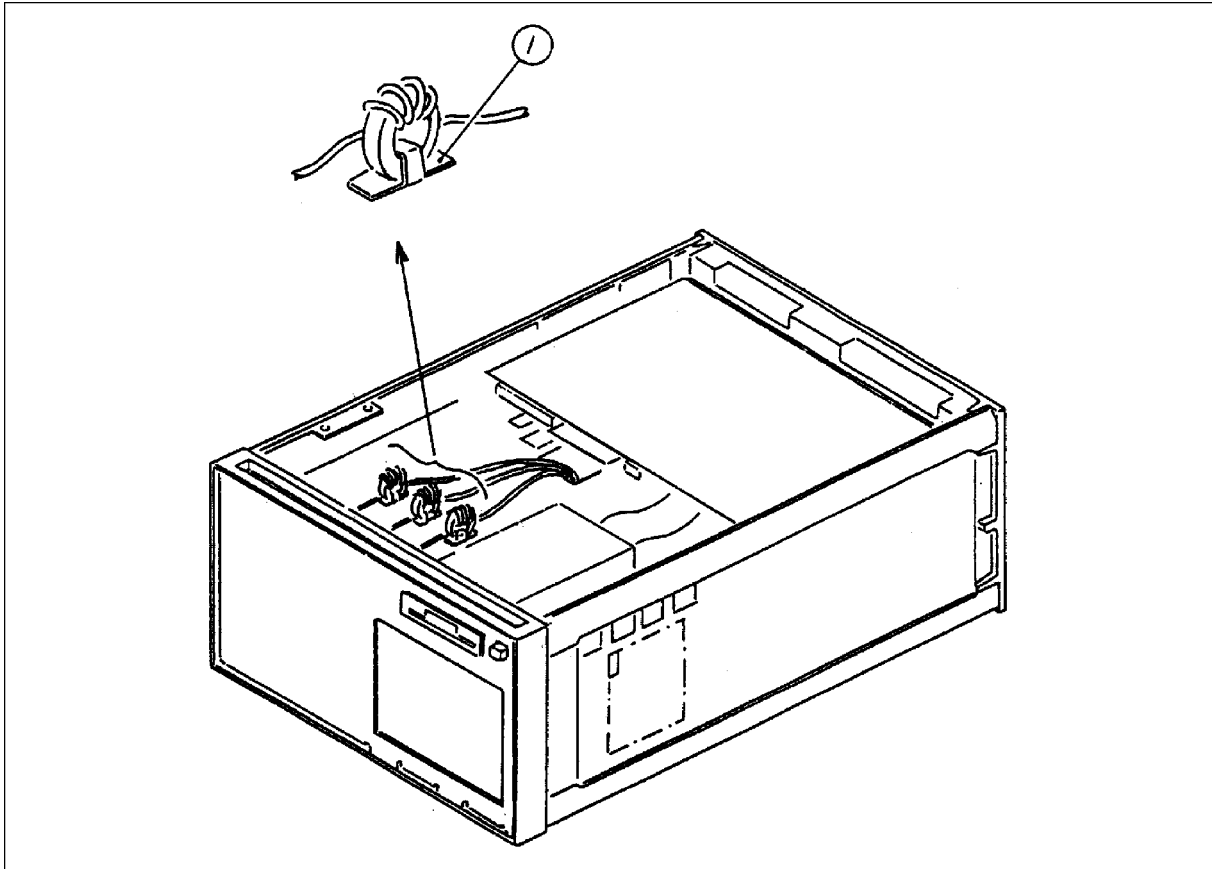

CDS11029

Figure 11-32. Troidal Core

Table 11-34. Troidal Core

Ref. Desig.	Agilent Part Number	C D	Qty.	Description	Mfr Code	Mfr Part Number
1	1400-1334	6	3	Clamp Cable	28480	1400-1334

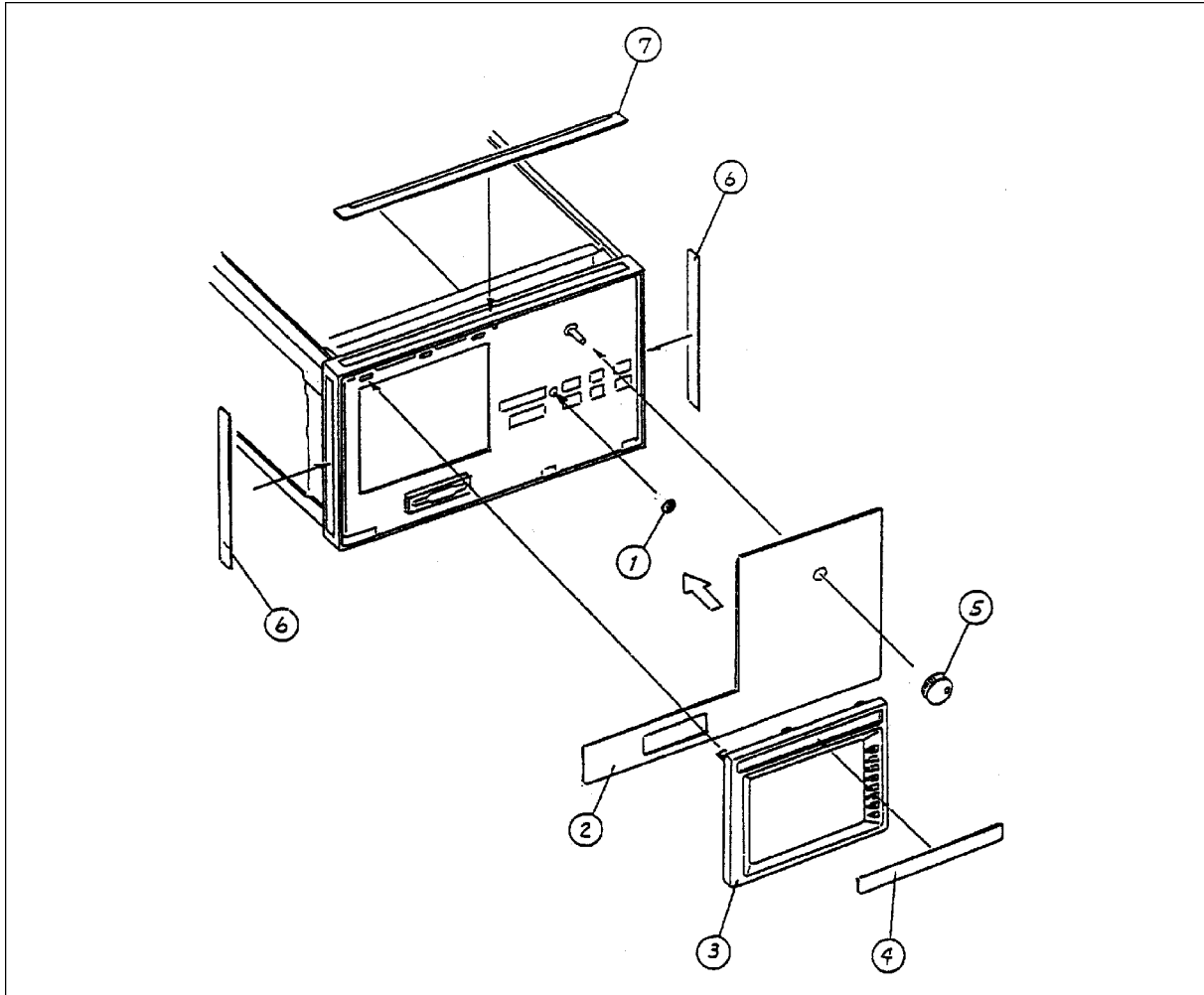

CDS11030

Figure 11-33. Front Bezel

Table 11-35. Front Bezel

Ref. Desig.	Agilent Part Number	C D	Qty.	Description	Mfr Code	Mfr Part Number
1	04191-08000	0	1	Spring	28480	04191-08000
2	04352-00221	6	1	Panel Front	28480	04352-00221
3	04396-40051	6	1	Bezel	28480	04396-40051
4	04352-87121	7	1	Label Front	28480	04352-87121
5	5182-7522	6	1	RPG Knob	28480	5182-7522
6	5041-9173	9	2	SIDE TRIM 221.5	28480	5041-9173
7	5041-9176	2	1	Trim Strip	28480	5041-9176

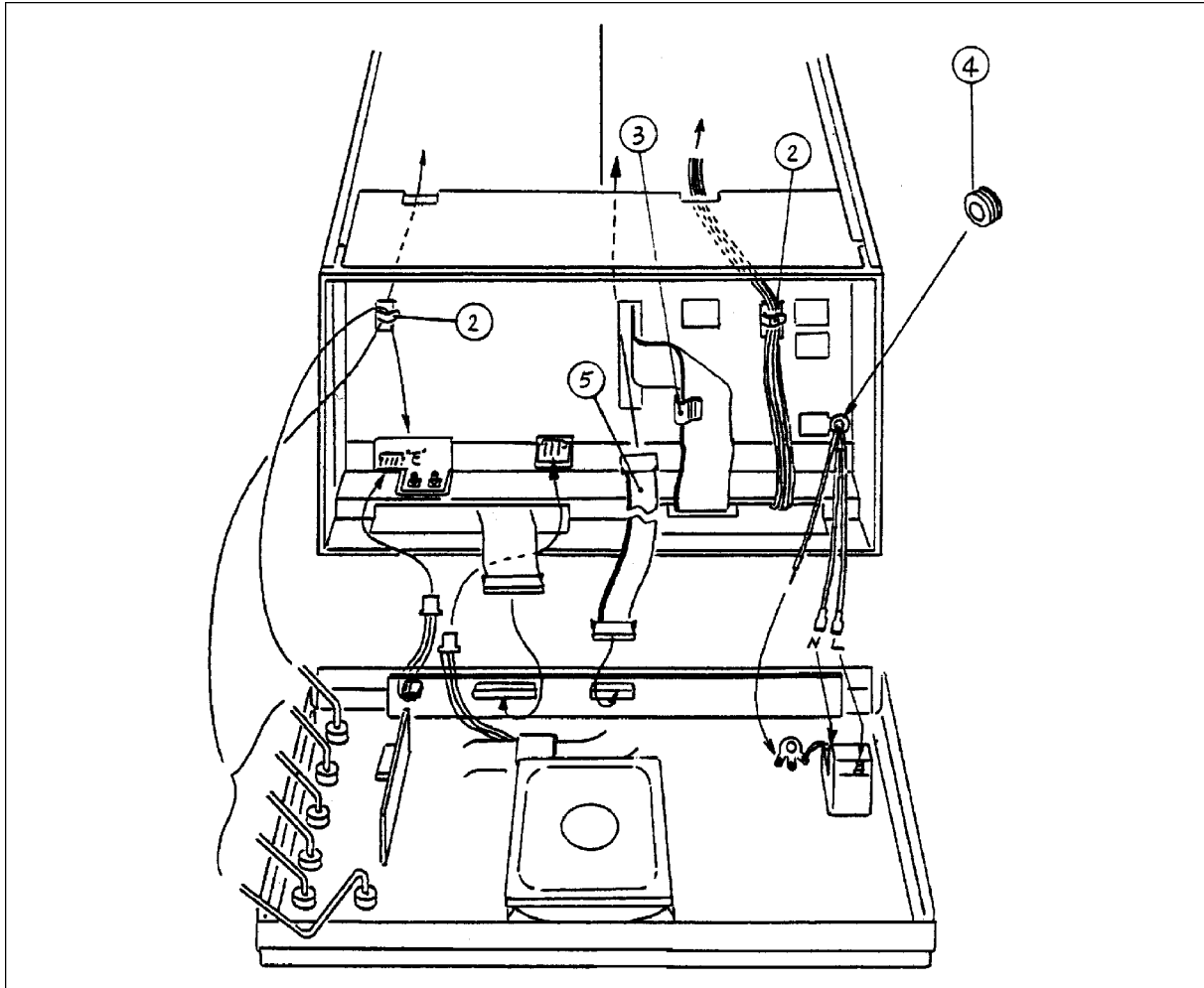

CDS11031

Figure 11-34. Rear Panel Installation

Table 11-36. Rear Panel Installation

Ref. Desig.	Agilent Part Number	C	D	Qty.	Description	Mfr Code	Mfr Part Number
2	1400-1391	5		2	Clamp Cable	28480	1400-1391
3	1400-0611	0		1	Clamp-Cable	28480	1400-0611
4	0400-0276	2		1	GROM RND	28480	0400-0276
5	04396-61662	9		1	CA-ASSY FLAT 40	28480	04396-61662

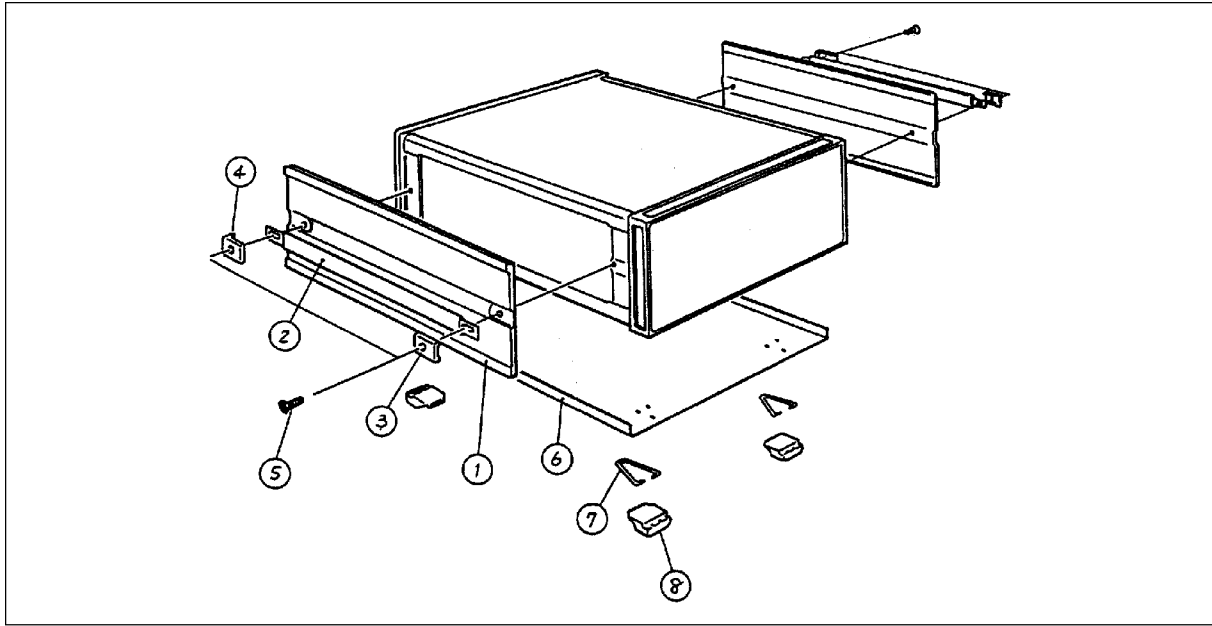

CDS11032

Figure 11-35. Covers

Table 11-37. Covers

Ref. Desig.	Agilent Part Number	C D	Qty.	Description	Mfr Code	Mfr Part Number
1	5002-3989	1	2	Cover Side REFE	28480	5002-3989
2	5063-9210	1	2	Strap Handle	28480	5063-9210
3	5041-9186	4	2	Strap Handle FRT	28480	5041-9186
4	5041-9187	5	2	Strap Handle Rear	28480	5041-9187
5	0515-1132	4	4	SCR-MACH M5X0.8	28480	0515-1132
6	5002-1088	7	1	Cover Bottom	28480	5002-1088
7	1460-1345	5	2	Wireform	28480	1460-1345
8	5041-9167	1	4	Foot FL	28480	5041-9167

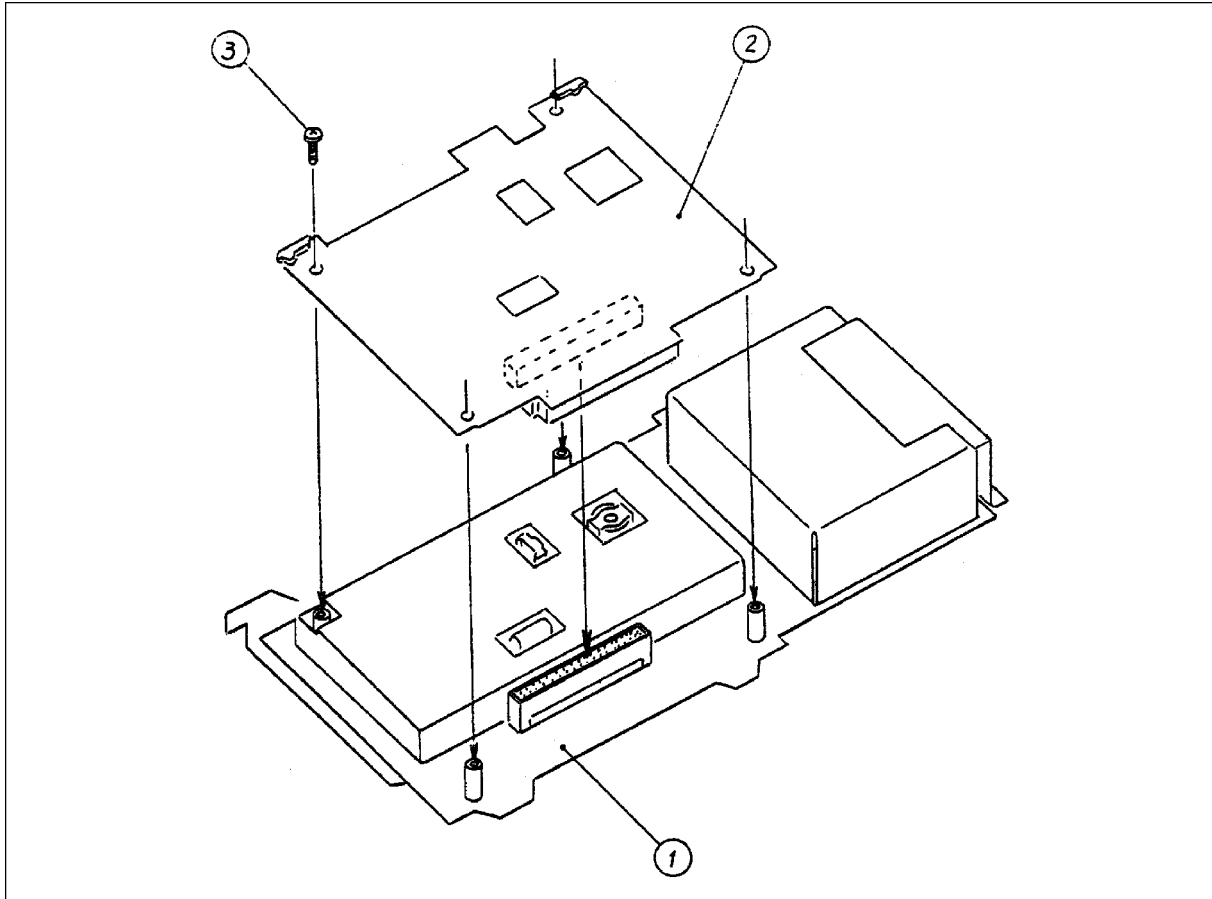

CDS11033

Figure 11-36. DC/FM Source Board ASSY

Table 11-38. DC/FM Source Board ASSY

Ref. Desig.	Agilent Part Number	C D	Qty.	Description	Mfr Code	Mfr Part Number
1	04352-66513	7	1	A13 DC/FM Source Board	28480	04352-66513
2	04352-66503	5	1	A3 Connector Board	28480	04352-66503
3	0515-1550	0	4	SCR M3-L 8 P-H	28480	0515-1550

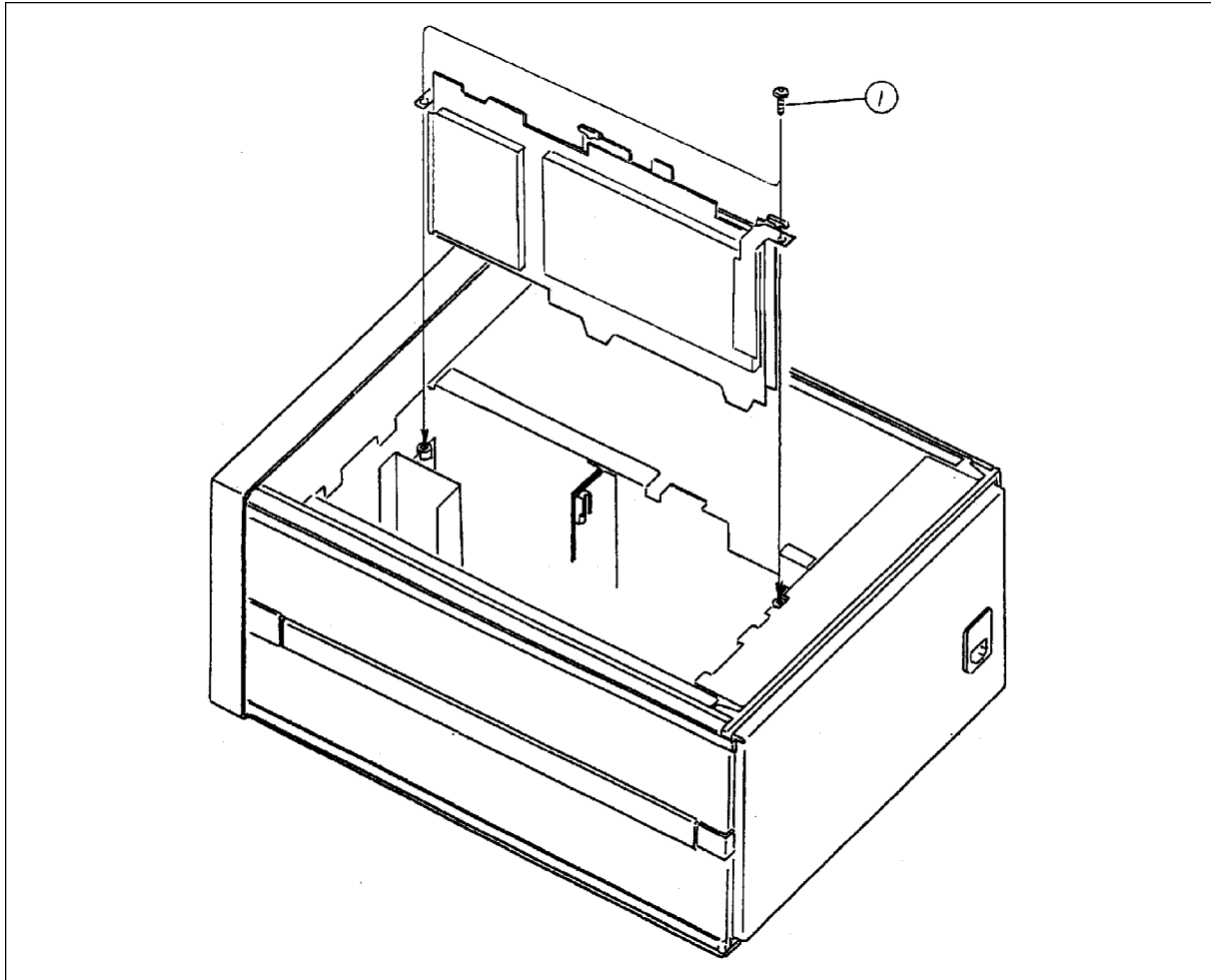

CDS11034

Figure 11-37. DC/FM Source Board Installation

Table 11-39. DC/FM Source Board Installation

Ref. Desig.	Agilent Part Number	C D	Qty.	Description	Mfr Code	Mfr Part Number
1	0515-2079	0	2	SCR M4X8	28480	0515-2079

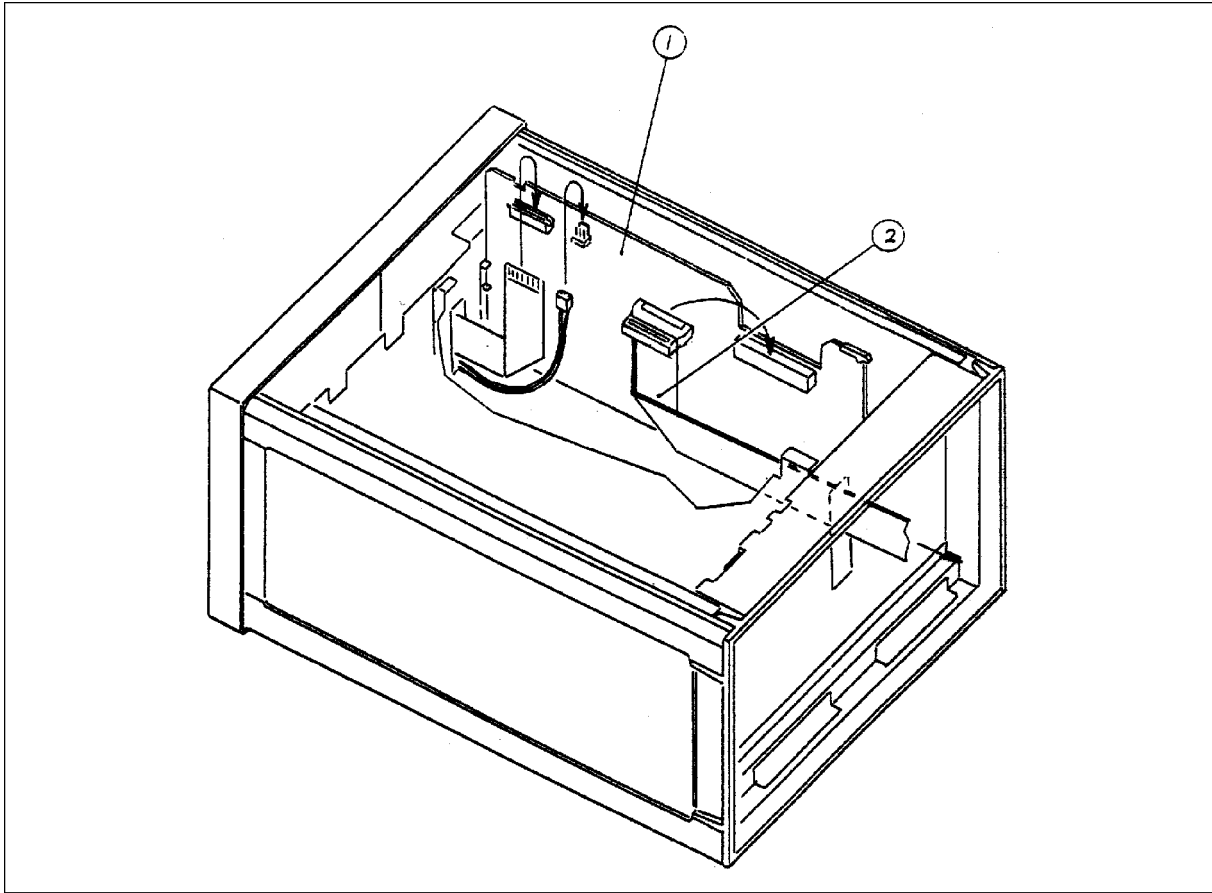

CDS11035

Figure 11-38. GSP Board Installation

Table 11-40. GSP Board Installation

Ref. Desig.	Agilent Part Number	C D	Qty.	Description	Mfr Code	Mfr Part Number
1	E4970-66552	4	2	A51 GSP Board	28480	E4970-66552
2	04396-61707	3	2	Cable ASSY	28480	04396-61707

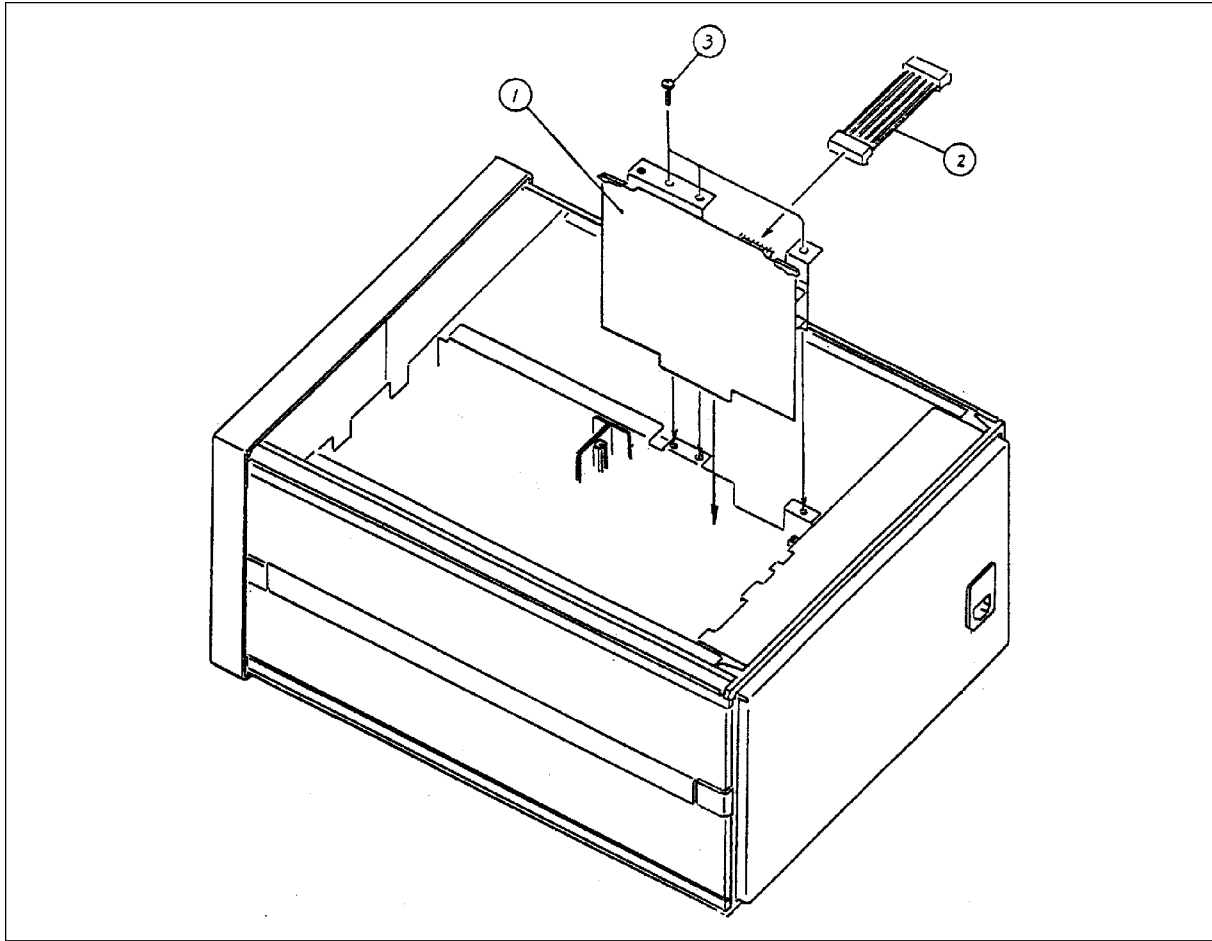

CDS11036

Figure 11-39. Post-Regulator Installation

Table 11-41. Post-Regulator Installation

Ref. Desig.	Agilent Part Number	C D	Qty.	Description	Mfr Code	Mfr Part Number
1	04396-66542	6	1	A2 Post Regulator	28480	04396-66542
2	04396-61674	3	1	Wire ASSY	28480	04396-61674
3	0515-1550	0	3	SCR M3-L 8 P-H	28480	0515-1550

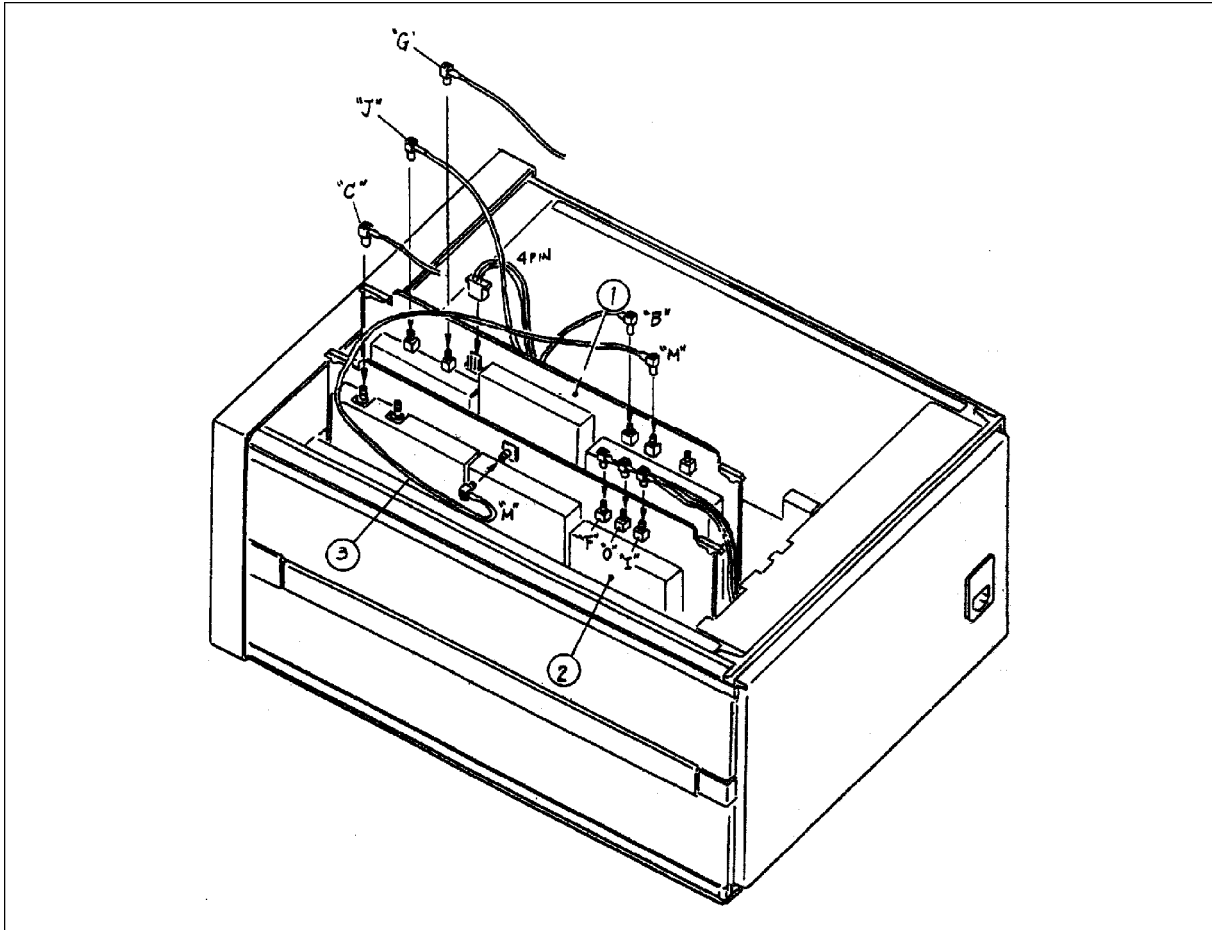

CDS11037

Figure 11-40. Receiver Board and Spe Ana Board

Table 11-42. Receiver Board and Spe Ana Board

Ref. Desig.	Agilent Part Number	C D	Qty.	Description	Mfr Code	Mfr Part Number
1	04352-66515	7	1	A5 Receiver Board	28480	04352-66515
2	04352-66506	8	1	A6 Spe. Ana. Section Board	28480	04352-66506
3	04396-61626	5	1	RF CBL ASSY	28480	04396-61626

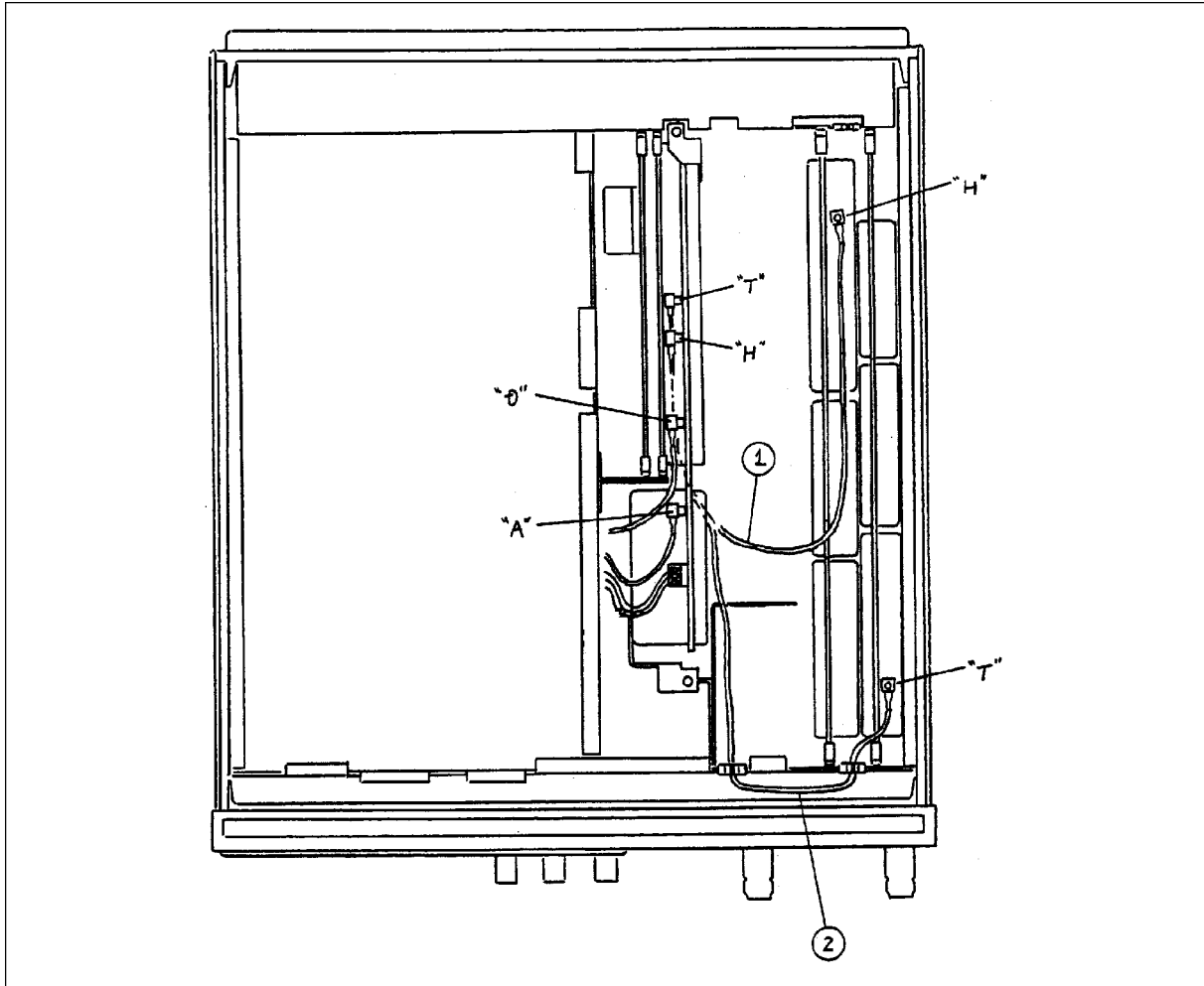

CDS11038

Figure 11-41. Cables

Table 11-43. Cables

Ref. Desig.	Agilent Part Number	C D	Qty.	Description	Mfr Code	Mfr Part Number
1	04352-61611	6	1	RF CBL ASSY	28480	04352-61611
2	04351-61618	2	1	RF CBL ASSY	28480	04351-61618

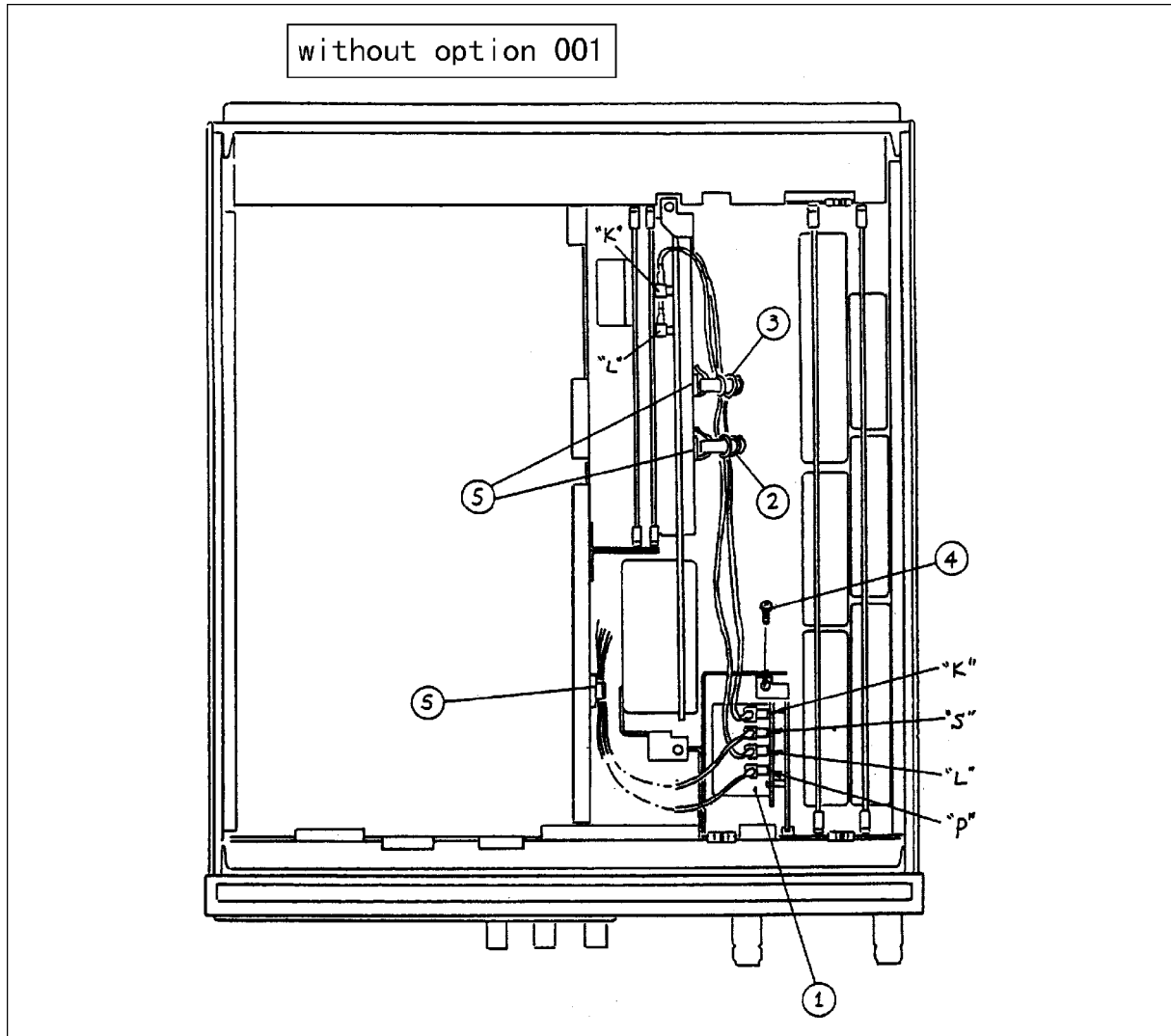

CDS11039

Figure 11-42. Output Filter ASSY

Table 11-44. Output Filter ASSY

Ref. Desig.	Agilent Part Number	C	D	Qty.	Description	Mfr Code	Mfr Part Number
1	04352-66560	4		1	A60 Output Filter	28480	04352-66560
2	04352-61616	1		1	Cable-RF	28480	04352-61616
3	04352-61617	2		1	Cable-RF	28480	04352-61617
4	0515-1550	0		1	SCR M3-L 8 P-H	28480	0515-1550
5	1400-1391	5		3	Clamp Cable	28480	1400-1391

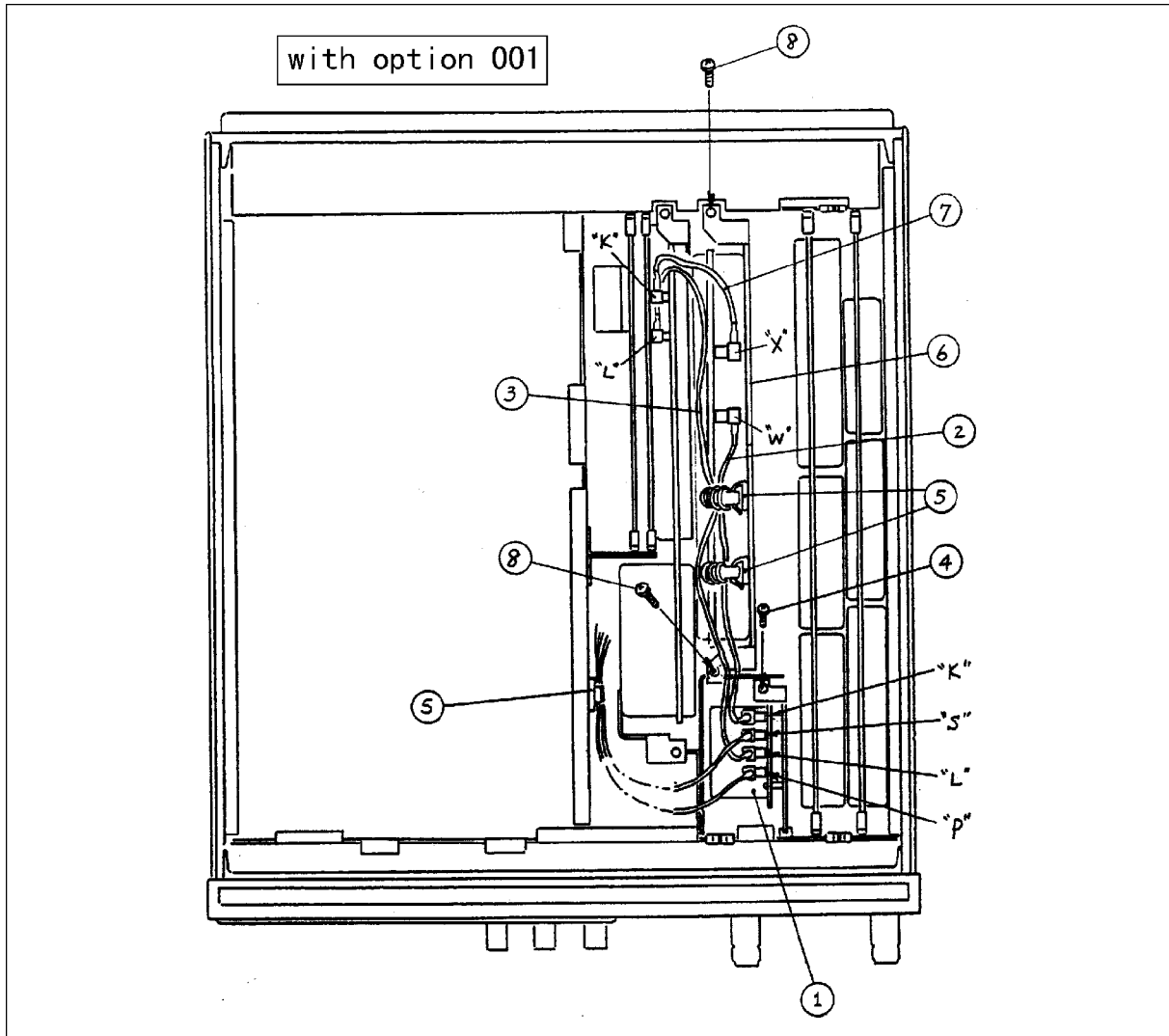

CDS11040

Figure 11-43. DC Offset (Option 001)

Table 11-45. DC Offset (Option 001)

Ref. Desig.	Agilent Part Number	C	D	Qty.	Description	Mfr Code	Mfr Part Number
1	04352-66560	4		1	A60 Output Filter	28480	04352-66560
2	04352-61631	0		1	RF FLEX COAX	28480	04352-61631
3	04352-61617	2		1	Cable-RF	28480	04352-61617
4	0515-1550	0		1	SCR M3-L 8 P-H	28480	0515-1550
5	1400-1391	5		3	Clamp Cable	28480	1400-1391
6	04352-66540	0		1	A70 DC Offset (Option 001 only)	28480	04352-66540
7	04352-61632	1		1	RF FLEX COAX	28480	04352-61632
8	0515-2079	0		2	SCR M4X8	28480	0515-2079

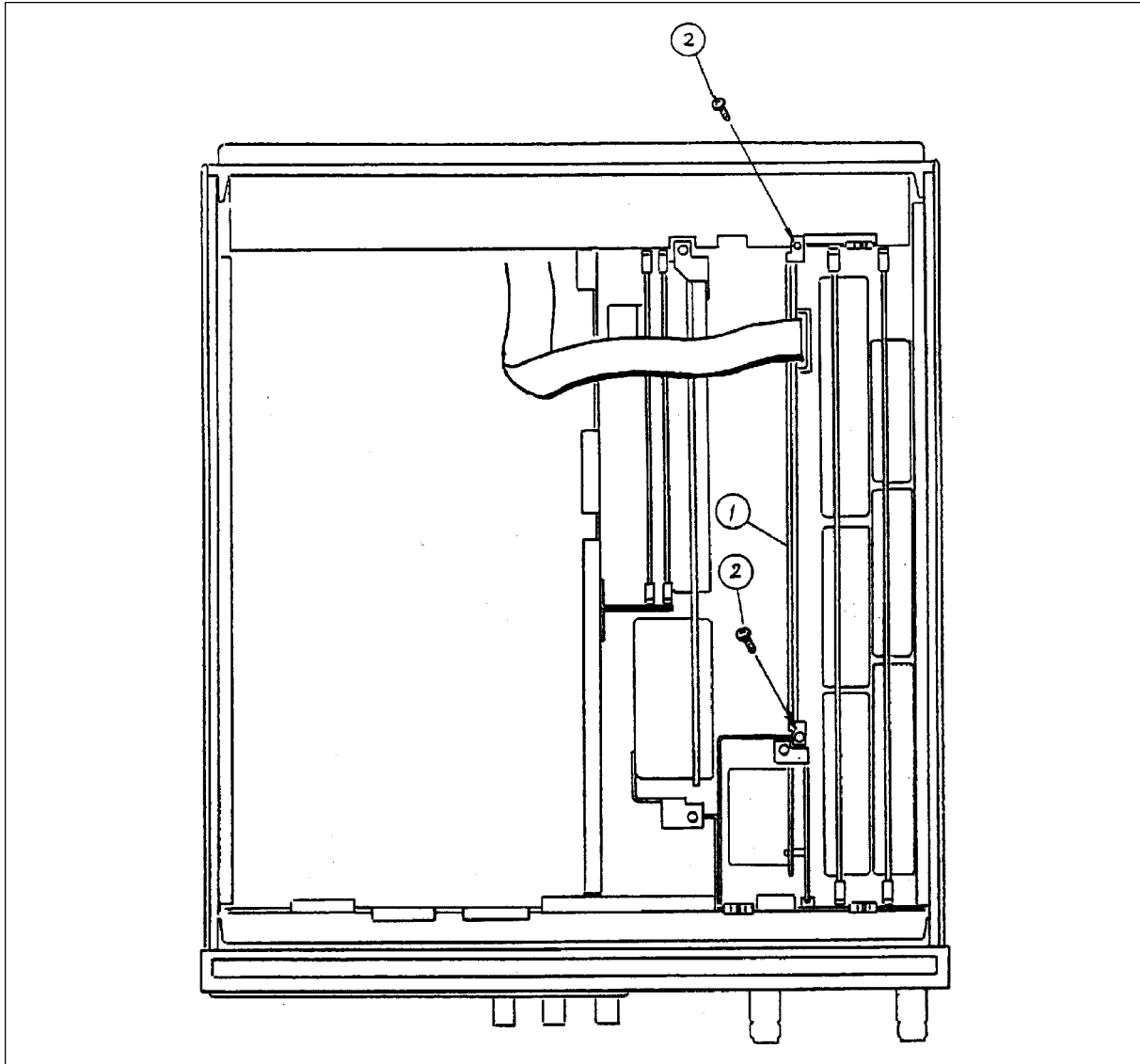

CDS11041

Figure 11-44. 24 Bit I/O Board

Table 11-46. 24 Bit I/O Board

Ref. Desig.	Agilent Part Number	C D	Qty.	Description	Mfr Code	Mfr Part Number
1	04351-66517	0	1	A17 24 Bit I/O Board	28480	04351-66517
2	0515-2079	0	2	SCR M4X8	28480	0515-2079

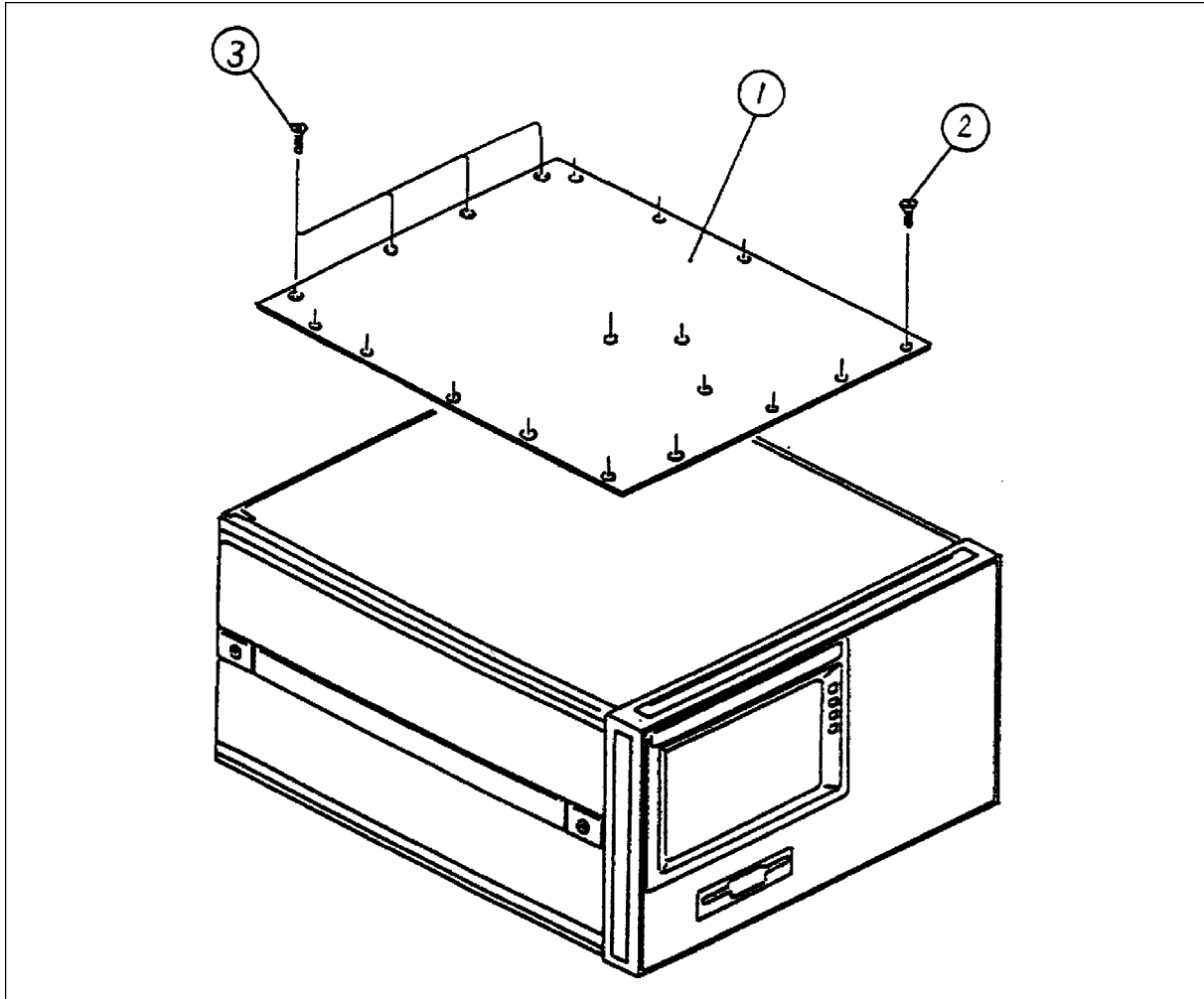

CDS11042

Figure 11-45. Top Shield Plate

Table 11-47. Top Shield Plate

Ref. Desig.	Agilent Part Number	C D	Qty.	Description	Mfr Code	Mfr Part Number
1	04352-00621	0	1	Shield Top	28480	04352-00621
2	0515-0914	8	15	SCR-MACH M3X0.5	28480	0515-0914
3	0515-0913	7	4	SCR-MACH M4X0.7	28480	0515-0913

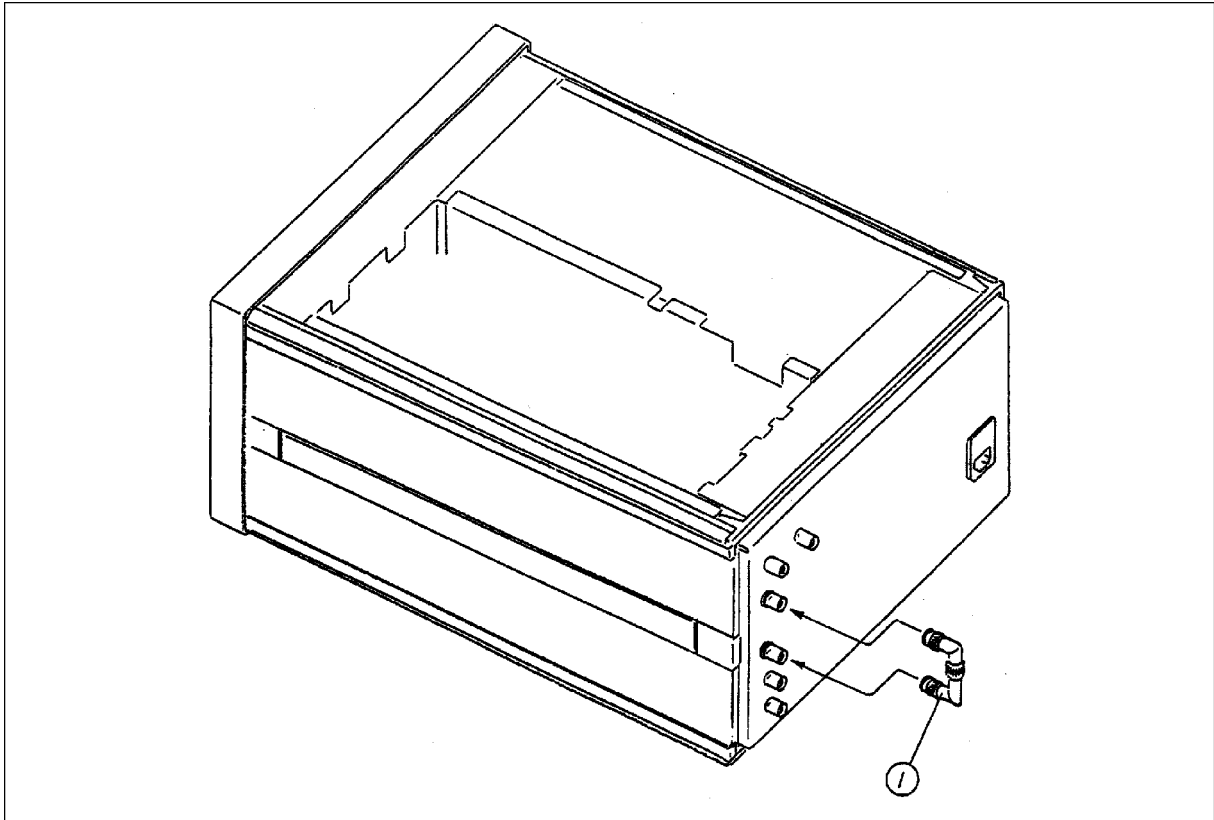

CDS11043

Figure 11-46. BNC-BNC Adapter

Table 11-48. BNC-BNC Adapter

Ref. Desig.	Agilent Part Number	C D	Qty.	Description	Mfr Code	Mfr Part Number
1	1250-1859	1	1	ADPTER-COAX	28480	1250-1859

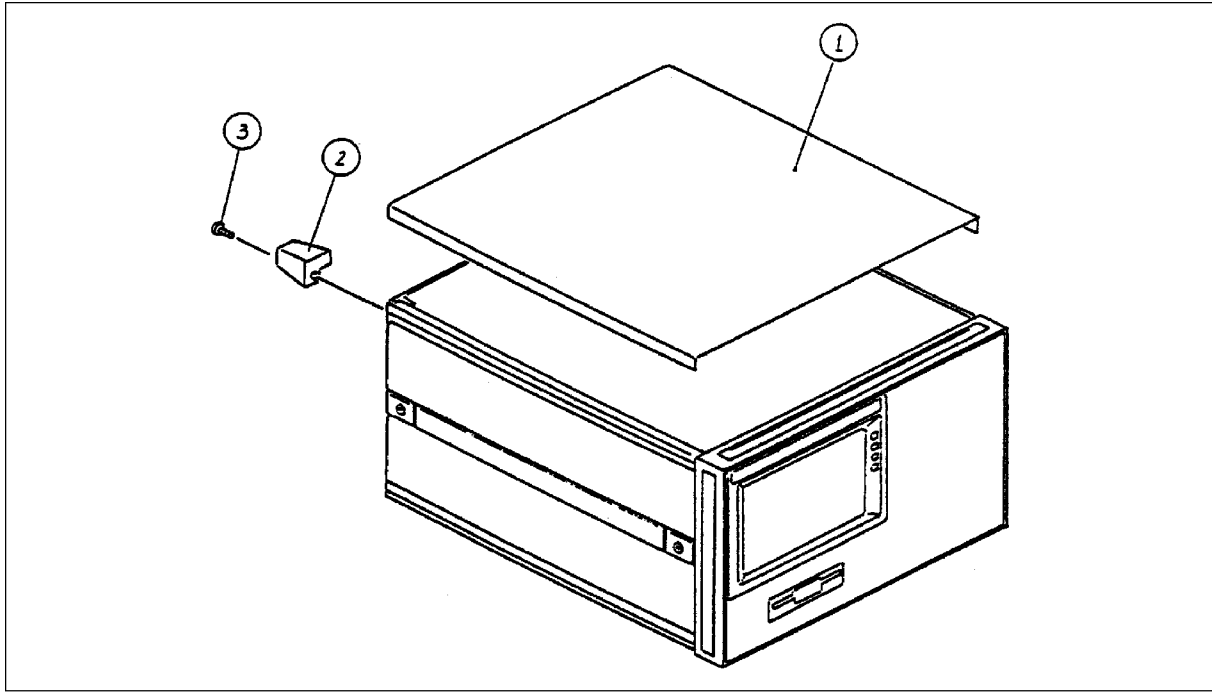

CDS11044

Figure 11-47. Top Covers/Foot

Table 11-49. Top Covers/Foot

Ref. Desig.	Agilent Part Number	C	D	Qty.	Description	Mfr Code	Mfr Part Number
1	5002-1047	8		1	Cover Top	28480	5002-1047
2	5041-9188	6		4	Foot Rear	28480	5041-9188
3	0515-1232	1		4	SCR-MACH M3.5	28480	0515-1232

Post Repair Procedures

INTRODUCTION

This chapter lists the procedures required to verify the analyzer operation after an assembly is replaced with a new one.

POST REPAIR PROCEDURES

Table 12-1 *Post Repair Procedures* lists the required procedures that must be performed after the replacement of an assembly or the EEPROM. These are the minimum recommended procedures to ensure that the analyzer is working properly following the replacement.

When you replace an assembly or the EEPROM on the A1 CPU, perform the adjustments and updating correction constants (CC) listed in Table 12-1. Then perform the operational verifications and performance verifications listed in Table 12-1.

For the detailed procedure of the adjustments and updating correction constants, see the *Adjustments and Correction Constants* Chapter. For detailed operational verification procedures, see this manual's chapter specified in Table 12-1. For detailed performance verification procedures, see the *Performance Tests* Chapter in this manual.

Table 12-1. Post Repair Procedures

Replaced Assembly or Part	Adjustments Correction Constants (CC)	Verification
A1 CPU	Firmware Installation ¹	<i>INSPECT THE POWER ON SEQUENCE</i> ² Internal Test 1: A1 CPU ³ Internal Test 2: A1 VOLATILE MEMORY ³
A1 EEPROM	EEPROM Initialization Display Background Crystal Filter Frequency Response CC FV Converter CC DC Power Voltage CC DC Control Voltage CC MOD OUT Level CC RF Power CC Spectrum Measurement CC	<i>INSPECT THE POWER ON SEQUENCE</i> ² <i>OPERATOR'S CHECK</i> ² Frequency Measurement RF Power Measurement Accuracy C/N Phase Noise C/N Meas. Accuracy (Flatness) C/N Meas. Accuracy (Linearity) FM Deviation Test DC Power Voltage DC Control Voltage MOD OUT Level Accuracy DC Power Current Spectrum Measurement Relative Level Accuracy Frequency Transient Frequency Accuracy
A2 Postregulator A50 DC-DC Converter	None	<i>INSPECT THE POWER ON SEQUENCE</i> ² Internal Test 4: A2 POST REGULATOR ⁴
A5 2nd PLL	FV Converter CC Spectrum Measurement CC	<i>INSPECT THE POWER ON SEQUENCE</i> ² Frequency Measurement C/N Phase Noise C/N Meas. Accuracy (Flatness) C/N Meas. Accuracy (Linearity) FM Deviation Spectrum Measurement Relative Level Accuracy Frequency Transient Frequency Accuracy

- 1 See the *Firmware Installation* in this chapter.
- 2 See the *Overall Troubleshooting* chapter.
- 3 See the *Digital Control Troubleshooting* chapter.
- 4 See the *Power Supply Troubleshooting* chapter.

Table 12-1. Post Repair Procedures (continued)

Replaced Assembly or Part	Adjustments Correction Constants (CC)	Verification
A6 Spectrum Analyzer	Internal Reference Frequency Third Mixer Feedthrough Third IF Amp Gain Crystal Filter Frequency Response CC FV Converter CC DC Power Current CC RF Power CC Spectrum Measurement CC	<i>INSPECT THE POWER ON SEQUENCE</i> ¹ Frequency Measurement Power Measurement Accuracy C/N Phase Noise C/N Meas.Accuracy (Flatness) C/N Meas.Accuracy (Linearity) MOD OUT Voltage DC Power Current Spectrum Measurement Relative Level Accuracy Frequency Transient Frequency Accuracy
A7 Power Divider	RF Power CC Spectrum Measurement CC	<i>INSPECT THE POWER ON SEQUENCE</i> ¹ RF Power Measurement Accuracy C/N Meas. Accuracy (Flatness)
A8 RF Attenuator	RF Power CC Spectrum Measurement CC	<i>INSPECT THE POWER ON SEQUENCE</i> ¹ RF Power Measurement Accuracy C/N Meas. Accuracy (Flatness)
A9 Peak Detector	RF Power CC Spectrum Measurement CC	<i>INSPECT THE POWER ON SEQUENCE</i> ¹ RF Power Measurement Accuracy
A10 1st Mixer	RF Power CC Spectrum Measurement CC	<i>INSPECT THE POWER ON SEQUENCE</i> ¹ Frequency Measurement RF Power Measurement Accuracy C/N Meas. Accuracy (Flatness) C/N Meas. Accuracy (Linearity)
A11 Thermometer	RF Power CC	<i>INSPECT THE POWER ON SEQUENCE</i> ¹ RF Power Measurement Accuracy
A13 Source	FV Converter CC DC Power Voltage CC DC Power Current CC DC Control Voltage CC MOD OUT Level CC RF Power CC	<i>INSPECT THE POWER ON SEQUENCE</i> ¹ C/N Phase Noise FM Deviation DC Power Voltage DC Control Voltage MOD OUT voltage DC Power Current

¹ See the *Overall Troubleshooting* chapter.

Table 12-1. Post Repair Procedures (continued)

Replaced Assembly or Part	Adjustments Correction Constants (CC)	Verification
A17 24 Bit I/O Port	None	<i>INSPECT THE POWER ON SEQUENCE</i> ¹ External Test 13: 24 BIT I/O PORT ²
A20 Motherboard	None	<i>INSPECT THE POWER ON SEQUENCE</i> ¹ <i>OPERATOR'S CHECK</i> ¹
A30 Keyboard	None	<i>INSPECT THE POWER ON SEQUENCE</i> ¹ External Test 11: FRONT PANEL DIAG. ²
A31 I/O Connector	None	<i>INSPECT THE POWER ON SEQUENCE</i> ¹
A32 I-BASIC Interface	None	<i>INSPECT THE POWER ON SEQUENCE</i> ¹ Check the A32 I-BASIC Interface and mini-DIN keyboard ²
A40 Pre-Regulator	None	<i>INSPECT THE POWER ON SEQUENCE</i> ¹ Internal Test 4: A2 POST REGULATOR ³
A51 GSP	Display Background	<i>INSPECT THE POWER ON SEQUENCE</i> ¹ Internal Test 3: GSP ²
A52 LCD	Vertical Position and Focus (if needed) Display Background	<i>INSPECT THE POWER ON SEQUENCE</i> ¹
A53 FDD	None	<i>INSPECT THE POWER ON SEQUENCE</i> ¹ External Test 12: DSK DR FAULTY ISOLN ²
A60 DC Source LPF	None	<i>INSPECT THE POWER ON SEQUENCE</i> ¹ DC Power Voltage DC Control Voltage DC Power Current

1 See the *Overall Troubleshooting* chapter.

2 See the *Digital Control Troubleshooting* chapter.

3 See the *Power Supply Troubleshooting* chapter.

Manual Changes

Introduction

This Appendix contains the information required to adapt this manual to earlier versions or configurations of the 4352B than the current printing date of this manual. The information in this manual applies directly to the 4352B VCO/PLL Signal Analyzer serial number prefix listed on the title page of this manual.

Manual Changes

To adapt this manual to your 4352B, refer to Table A-1 and Table A-2, and make all of the manual changes listed opposite your instrument's serial number and firmware version.

Instruments manufactured after the printing of this manual may be different than those documented in this manual. Later instrument versions will be documented in a manual changes supplement that will accompany the manual shipped with that instrument. If your instrument's serial number is not listed on the title page of this manual or in Table A-1, it may be documented in a *yellow MANUAL CHANGES* supplement.

Turn on the line switch or execute the “*IDN?” command by GPIB to confirm the firmware version. See *GPIB Command Reference* for information on the “*IDN?” command. For additional information on serial number coverage, see chapter 1 of the *Function Reference*.

Table A-1. Manual Changes by Serial Number

Serial Prefix or Number	Make Manual Changes
JPIKE00195 or below	Change 1

Table A-2. Manual Changes by Firmware Version

Version	Make Manual Changes

Change 1

Change the Replaceable Parts as following.

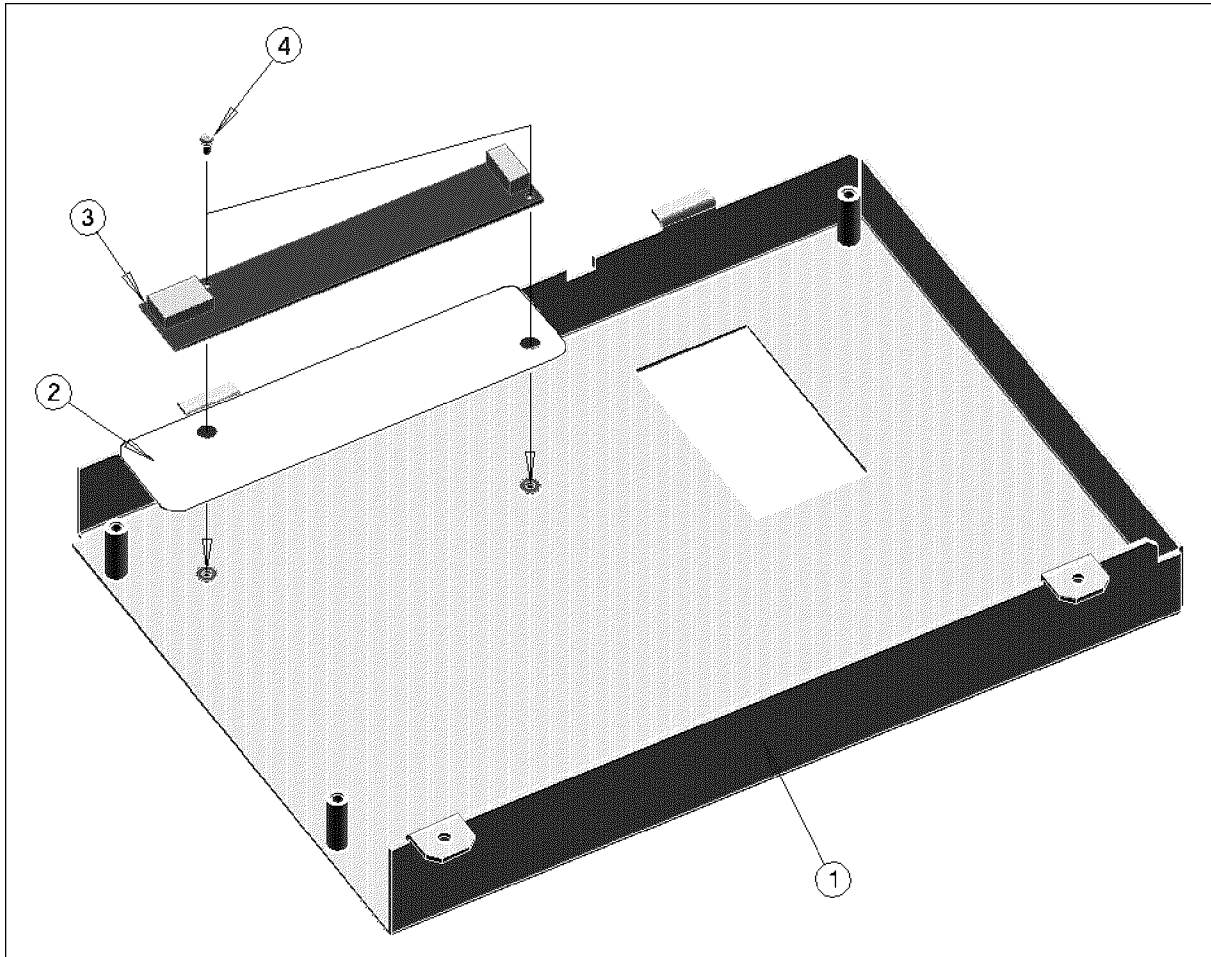

CDS11005

Figure A-1. Front Assembly Parts 5

Table A-3. Front Assembly Parts 5

Ref. Desig.	Agilent Part Number	C D	Qty.	Description	Mfr Code	Mfr Part Number
1	E4970-04002	3	1	Cover	28480	E4970-04002
2	E4970-25002	8	1	Insulator	28480	E4970-25002
3	0950-2924	6	1	A54 Inverter Board	28480	0950-2924
4	0515-0977	3	2	SCR-MACH M2X0.4	28480	0515-0977

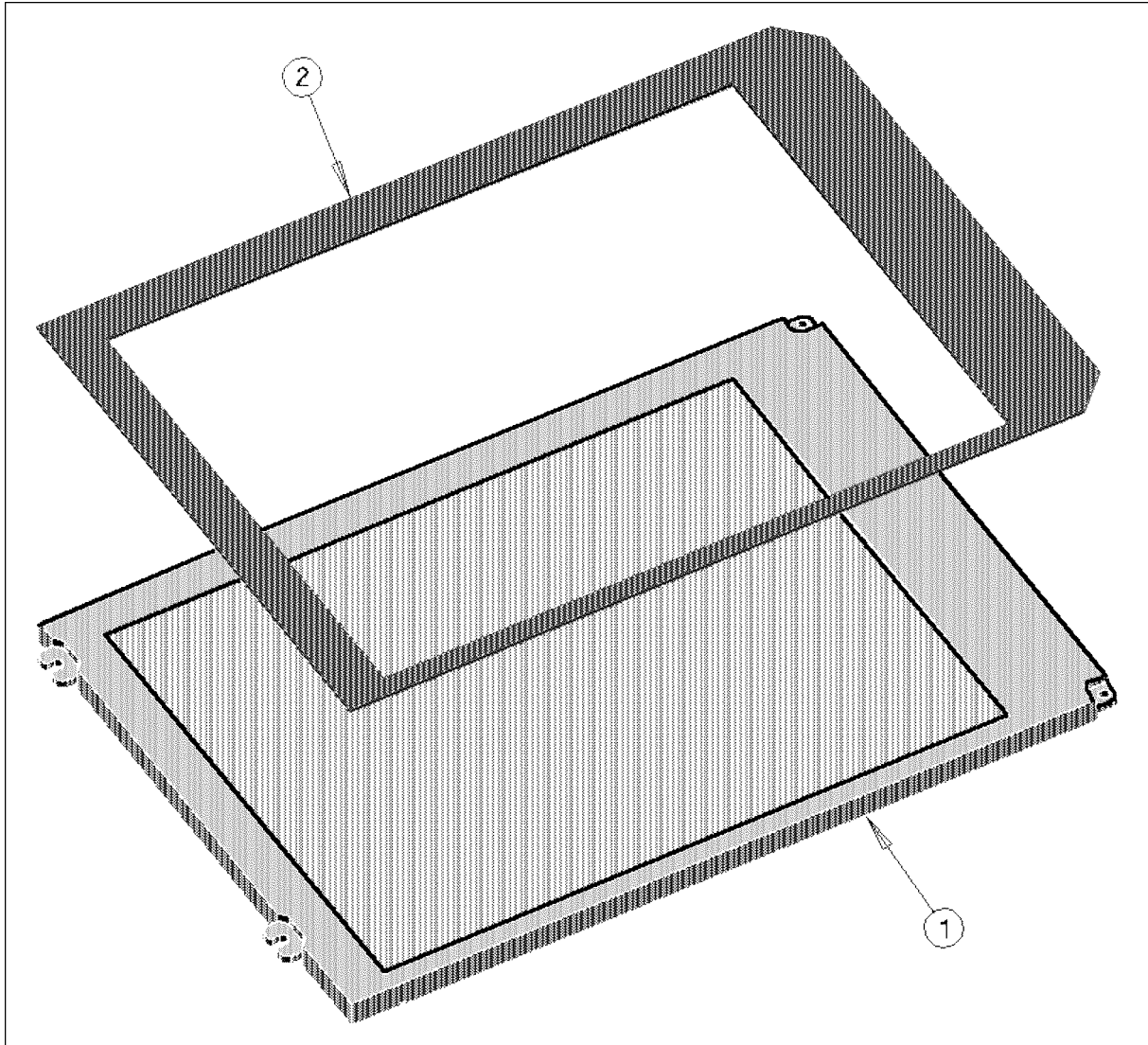

CDS11006

Figure A-2. Front Assembly Parts 6

Table A-4. Front Assembly Parts 6

Ref. Desig.	Agilent Part Number	C D	Qty.	Description	Mfr Code	Mfr Part Number
1	(Not Available)	7	1	A52 LCD (See Service Note 4352B-1)	28480	2090-0574
2	04396-25071	8	1	Gasket	28480	04396-25071

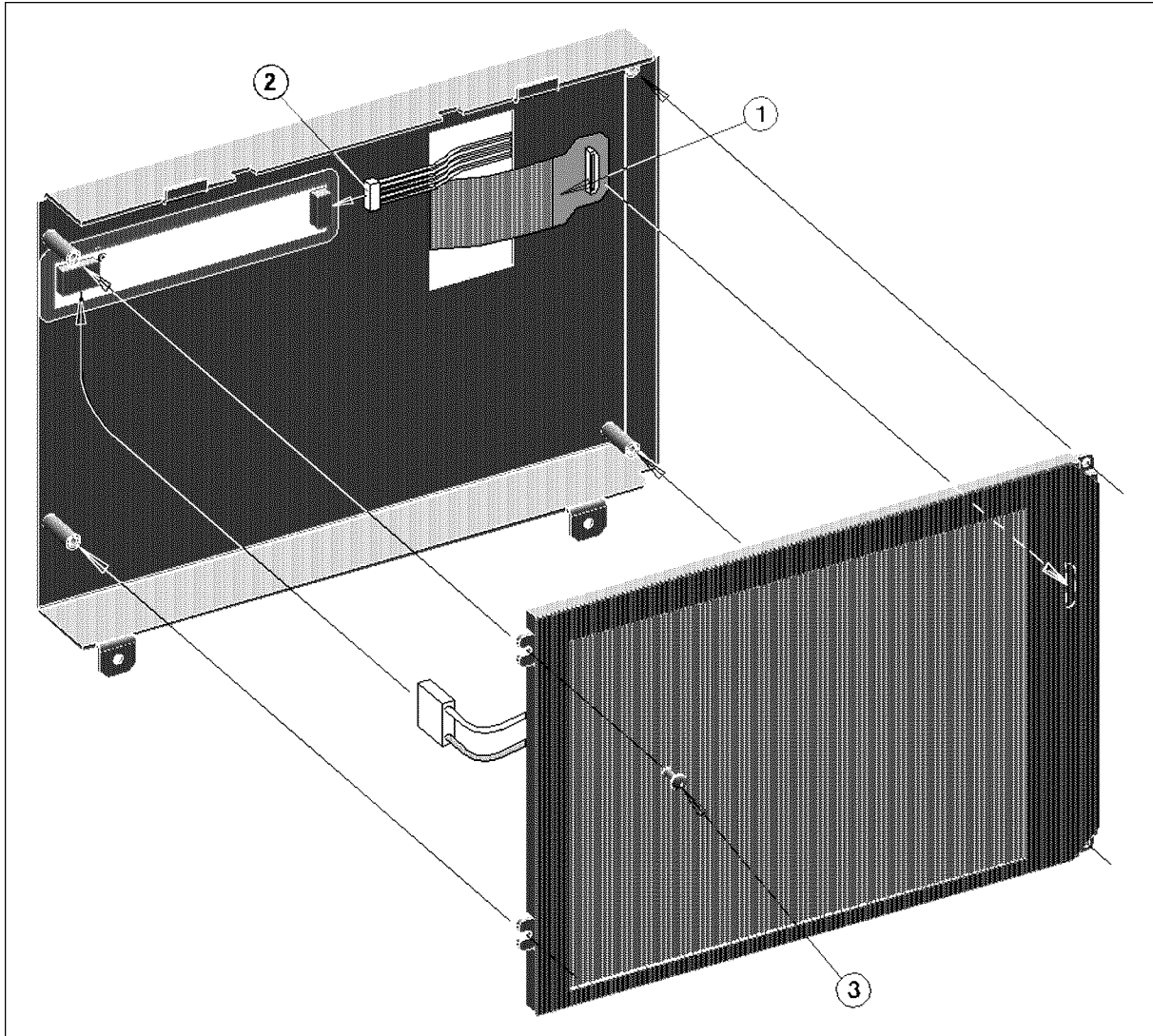

CDS11007

Figure A-3. Front Assembly Parts 7

Table A-5. Front Assembly Parts 7

Ref. Desig.	Agilent Part Number	C	D	Qty.	Description	Mfr Code	Mfr Part Number
1	E4970-61651	4		1	Flex PCBD ASSY	28480	E4970-61651
2	04396-61709	5		1	Cable ASSY	28480	04396-61709
3	0515-1550	0		4	SCR M3-L 8 P-H	28480	0515-1550

Serial Number

Agilent Technologies uses a two-part, ten-character serial number that is stamped on the serial number plate (see Figure A-4) attached to the rear panel. The first five digits and the letter are the serial prefix and the last five digits are the suffix.



Figure A-4. Serial Number Plate

Power Requirement

Replacing Fuse

Fuse Selection

Select proper fuse according to the Table B-1.

Table B-1. Fuse Selection

Fuse Rating/Type	Fuse Part Number
5A 250Vac UL/CSA type Time Delay	2110-0030

For ordering the fuse, contact your nearest Agilent Technologies Sales and Service Office.

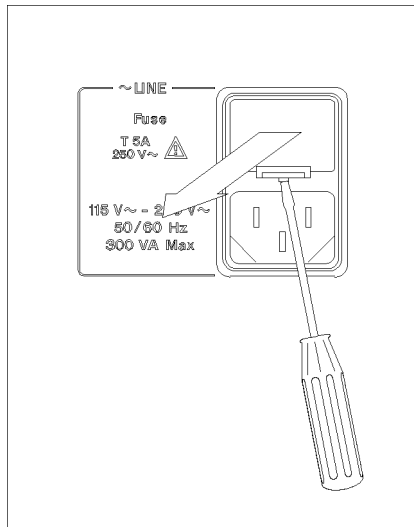

Lever a small minus screwdriver to dismount the fuse holder above the AC line receptacle on the rear panel.

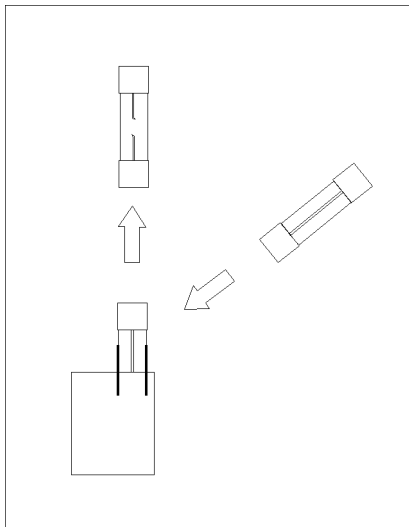

To check or replace the fuse, pull the fuse holder and remove the fuse. To reinstall the fuse, insert a fuse with the proper rating into the fuse holder.

Power Requirements

The 4352B requires the following power source:

Voltage : 90 to 132 Vac, 198 to 264 Vac

Frequency : 47 to 63 Hz

Power : 300 VA maximum

Power Cable

In accordance with international safety standards, this instrument is equipped with a three-wire power cable. When connected to an appropriate ac power outlet, this cable grounds the instrument frame.

The type of power cable shipped with each instrument depends on the country of destination. Refer to Figure B-1 for the part numbers of the power cables available.

Warning



For protection from electrical shock, the power cable ground must not be defeated.

The power plug must be plugged into an outlet that provides a protective earth ground connection.

<p>OPTION 900</p>  <p>Plug : BS 1363A, 250V Cable : HP 8120-1351</p>	<p>OPTION 901</p>  <p>Plug : NZSS 198/AS C112, 250V Cable : HP 8120-1369</p>
<p>OPTION 902</p>  <p>Plug : CEE-VII, 250V Cable : HP 8120-1689</p>	<p>OPTION 903</p>  <p>Plug : NEMA 5-15P, 125V, 15A Cable : HP 8120-1378</p>
<p>OPTION 904</p>  <p>Plug : NEMA 6-15P, 250V, 15A Cable : HP 8120-0698</p>	<p>OPTION 906</p>  <p>Plug : SEV 1011.1959-24507 Type 12, 250V Cable : HP 8120-2104</p>
<p>OPTION 912</p>  <p>Plug : DHCR 107, 220V Cable : HP 8120-2956</p>	<p>OPTION 917</p>  <p>Plug : SABS 164, 250V Cable : HP 8120-4211</p>
<p>OPTION 918</p>  <p>Plug : JIS C 8303, 125V, 15A Cable : HP 8120-4753</p>	<p>OPTION 922</p>  <p>Plug : GB 1002, 250V Cable : HP 8120-8376</p>
<p>NOTE: Each option number includes a 'family' of cords and connectors of various materials and plug body configurations (straight, 90° etc.).</p>	

Figure B-1. Power Cable Supplied

Error Message

This section lists the error messages that are displayed on the 4352B display or transmitted by the instrument over GPIB. Each error message is accompanied by an explanation, and suggestions are provided to help in solving the problem. Where applicable, references are provided to the related chapter of the appropriate manual.

When displayed, error messages are preceded with the word "CAUTION:." That part of the error message has been omitted here for the sake of brevity. Some messages without the "CAUTION:" are for information only, and do not indicate an error condition. The messages are listed first in alphabetical order because the displayed messages do not contain the message number. The messages are then listed in numerical order to make them easier to find if they are read over the GPIB.

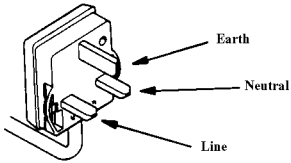
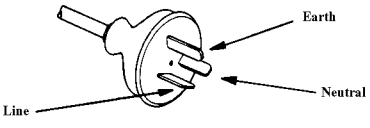
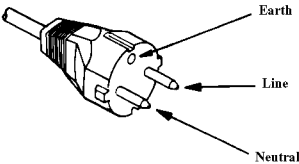
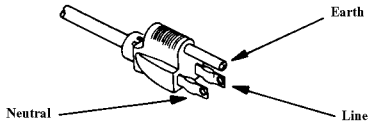
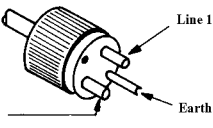
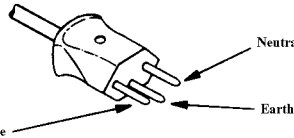
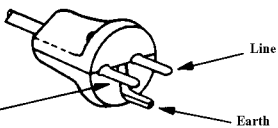
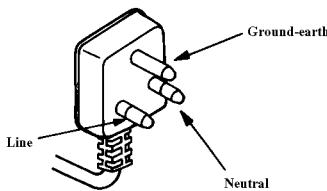
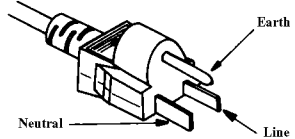
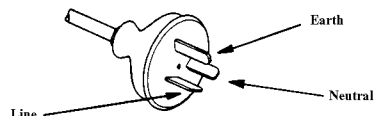
In addition to error messages, The 4352B's status is indicated by status notations in the left margin of the display. Examples are *, Cor, and P|. Sometimes these appear together with error messages. A complete listing of status notations and their meanings is provided in Chapter 2 in *4352B Function Reference*.

Errors with a negative number are errors that occurred when the 4352B was being controlled with GPIB commands over the GPIB.

Error Messages in Alphabetical Order

45 1st IF Out Of Range

The 4352B's 1st IF frequency is outside of the proper range.

Possible problems and the corrective action are shown below:

- The frequency of the external signal generator is not correct.
The 4352B has not performed automatic control of the external signal generator via GPIB (LO CONTROL MAN and/or ADDRESSABLE ONLY is selected). Verify the frequency of the external signal generator.
- The actual time required for the stabilization of the output frequency from the external signal generator after changing the output frequency exceeds the specified wait time in LOCAL SWITCH TIME .
Press (RF/LO), LOCAL SWITCH TIME , and the entry keys to increase the 4352B's wait time.
- The DUT output frequency fluctuated largely in a very short time (several hundred kHz in several tens of ms)
Verify the DUT's frequency stability.
- The automatic frequency control function was ON and the target frequency was 50 MHz or less.
Set the acceptable frequency deviation to 4% or less of the target frequency.

81 2nd PLL Unlocked

The 4352B's internal 2nd PLL cannot be locked. If this message is displayed during a C/N ratio measurement or a phase noise measurement, the following problems and the corrective action are shown below.

- The DUT's noise level is too large, or a large level spurious component exists in the measurement range.
Verify the spectrum of the DUT's output signal.
- The DUT's output signal is being modulated in frequency.
Press (Mod), MOD OUT on OFF to stop the frequency modulation.
- In the case of a DUT with an oscillation frequency of 100 MHz or less, a large harmonics component is included in the output signal (effect of TTL output, etc.).

Insert a low-pass filter between the DUT's output terminal and the 4352B RF IN connector to eliminate the harmonics component.

If this message is displayed any time other than during a C/N measurement, adjustment or repair is necessary. Contact our service office or the company from which you purchased the 4352B.

70 A/D Overload

The input level to the 4352B's internal A/D converter is too large.

Adjustment or repair is necessary. Contact our service office or the company from which you purchased the 4352B.

48 AFC Out Of Loop

The automatic frequency control function could not follow the fluctuation in the measurement condition, and did not converge on the target frequency.

Possible problems and the corrective action are shown below:

- The tuning sensitivity is improperly set.
Press **(Menu)**, **AUTO FREQ CONTROL**, **SENSITIVITY**, and the entry keys to specify a proper tuning sensitivity (the unit is [Hz/V]).
- The maximum value of the control voltage is too small.
Press **(Menu)**, **AUTO FREQ CONTROL**, **MAX CTRL VOLTAGE**, and the entry keys to specify a maximum value larger than the current setting. *Be careful not to set a value that exceeds the DUT's maximum acceptable value.*
- The math/measurement repeat count is too low.
Press **(Menu)**, **AUTO FREQ CONTROL**, **MAX ITERATION**, and the entry keys to specify a value larger than the current setting.
- An effect of the high value capacitor included with the DUT's power voltage (V_{cc}) terminal.
Press **(Menu)**, **AUTO FREQ CONTROL**, **CTRL DELAY**, and the entry keys to specify a value larger than the current setting.

102 ANALYZER TYPE MISMATCH

Indicates an invalid function was selected in the present measurement item. Change the measurement item, or select a different function.

13 BACKUP DATA LOST

Data checksum error on the battery backup memory has occurred. Wait until the battery is re-charged (approximately 10 minutes after turning the 4352B on).

-160 Block data error

The 4352B detected an invalid syntax in a block data element.

-168 Block data not allowed

A legal block data element was encountered but was not allowed by the 4352B at this point in parsing.

51 Calibration Aborted

The FM deviation calibration in progress was aborted. This was probably caused by changing the measurement parameters during the FM deviation calibration.

Perform the FM deviation calibration again.

100 CAN'T CHANGE- ANOTHER CONTROLLER ON BUS

The 4352B cannot assume the mode of system controller until the active controller is removed from the bus or relinquishes the bus. See the *4352B GPIB Programming Manual*.

144 CAN'T CHANGE NUMBER OF POINTS

The number of points in the spectrum measurement cannot be changed manually, except in zero span.

Error Messages (Alphabetical Order)

132 CAN'T SAVE GRAPHICS WHEN COPY IN PROGRESS

If you attempt to save graphics when a print is in progress, this error message is displayed. Wait until the print is completed, then save the graphics again.

–281 Cannot create program

Indicates that an attempt to create a program was unsuccessful. A reason for the failure might include not enough memory.

54 Carrier Overload

The carrier level in a C/N ratio measurement or a phase noise measurement is too large.

The 4352B RF IN connector's input level is too large. Verify the input level to the 4352B RF IN connector.

–140 Character data error

This error, as well as errors –141 through –148, are generated when analyzing the syntax of a character data element. This error message might be displayed if the 4352B detects an unknown problem.

–148 Character data not allowed

A legal character data element was encountered where prohibited by the 4352B.

–144 Character data too long

The character data element contains more than twelve characters (see IEEE 488.2, 7.7.1.4).

–100 Command error

This is a generic syntax error that the 4352B displays when it cannot detect more specific errors. This code indicates only that a command error, as defined in IEEE 488.2, 11.5.1.1.4, has occurred.

–110 Command header error

An error was detected in the header. This error message might be displayed if the 4352B detects an unknown problem related to errors –111 through –119.

77 DC Control Current Overload

The current through the DC CONTROL connector is too large (20 mA or more).

Possible problems and the corrective action are shown below:

- The DUT's control current is too large.
Verify that the DUT is correctly connected to the 4352B RF IN connector.
- An effect of the high value capacitor connected to the DUT's power voltage (V_{cc}) terminal.
This is a transient error. Press **DC Control**, **CTRL DELAY**, and the entry keys to set a sufficiently large value for elimination of this transient error.

52 DC Output On Required in AFC

The automatic frequency control function was set on, however, the power or control voltage is not being applied to the DUT.

Verify that the power/control voltages output is set to ON on the LCD display information (the measurement setting parameter display or the status notations). If the power/control voltage output is turned to OFF, press **DC Power** or **DC Control**, and **OUTPUT ON off**.

76 DC Power Current Overload

The current through the DC POWER connector is too large (50 mA or more).

Possible problems and the corrective action are shown below:

- The DUT's power current is too large.
Verify that the DUT is correctly connected to the 4352B.
- An effect of the high value capacitor connected to the DUT's power voltage (V_{cc}) terminal. This is a transient error. Wait until the DC POWER voltage is stabilized, then perform the measurement.

-230 Data corrupt or stale

Possibly invalid data. New reading started but not completed since last access.

-225 Data out of memory

The 4352B has insufficient memory to perform the requested operation.

-222 Data out of range

A legal program data element was parsed but could not be executed because the interpreted value was outside the legal range as defined by the 4352B (see IEEE 488.2, 11.5.1.1.5).

-231 Data questionable

Indicates that the measurement accuracy is suspect.

-104 Data type error

The parser recognized a data element that is not allowed. For example, numeric or string data was expected but block data was encountered.

135 DUPLICATE FILE EXTENSION

The extension name entered is already used for other file types. Use a different extension name.

-200 Execution error

This is the generic syntax error that the 4352B displays when it cannot detect more specific errors. This code indicates only that an execution error as defined in IEEE 488.2, 11.5.1.1.5 has occurred.

-123 Exponent too large

The magnitude of the exponent was larger than 32000 (see IEEE 488.2, 7.7.2.4.1).

Error Messages (Alphabetical Order)

44 F-V Input Overflow

The input frequency to the 4352B's F-V converter is too high.

This message indicates that the DUT's frequency has fluctuated widely in a very short time (several hundred kHz in several tens of ms). Verify the DUT's output frequency stability.

-257 FILE NAME ERROR

Indicates that a legal program command or query could not be executed because the file name on the device media was in error. For example, an attempt was made to copy to a duplicate file name. The definition of what constitutes a file name error is device-specific.

53 FM Deviation Range Overload

The DUT's FM deviation is out of the measurement range.

Press **(Sense Range)**, **FM DEV RANGE**, and select a measurement range larger than the current setting. (FM deviations over 200 kHz cannot be measured.)

43 F-V Input Underflow

The input frequency to the 4352B's F-V converter is too low.

This message indicates that the DUT's frequency has fluctuated widely in a very short time (several hundred kHz in several tens of ms). Verify the DUT's output frequency stability.

-105 GET not allowed

A Group Execute Trigger (GET) was received within a program message (see IEEE 488.2, 7.7).

-240 Hardware error

Indicates that a legal program command or query could not be executed because of a hardware problem in the 4352B. Definition of what constitutes a hardware problem is device-specific. This error message might be displayed if the 4352B detects an unknown problem related to errors -241 through -249.

-241 Hardware missing

A legal program command or query could not be executed because of missing 4352B hardware. For example, an option was not installed.

-111 Header separator error

A character that is not a legal header separator was encountered while parsing the header. For example, no white space followed the header, thus *SRE4 is an error.

-114 Header Suffix out of range

The value of a numeric suffix attached to a program mnemonic makes the header invalid.

-224 Illegal parameter value

Used where an exact value, from a list of possibilities, was expected.

Error Messages (Alphabetical Order)

–282 **Illegal program name**

The name used to reference a program was invalid. For example, redefining an existing program, deleting a nonexistent program, or in general, referencing a nonexistent program.

–283 **Illegal variable name**

An attempt was made to reference a nonexistent variable in a program.

–213 **Init ignored**

A request for a measurement initiation was ignored as another measurement was already in progress.

159 **INSUFFICIENT memory**

If a lot of tasks are executed at the same time, memory might be insufficient for a while. (For example, if running an HP Instrument BASIC program, printing a screen, and sending or receiving data array by GPIB are requested at the same time.) Wait until finishing some tasks then execute the next task.

40 **Insufficient RF Level**

The input level to the 4352B RF IN connector is too low (less than –20 dBm).

Verify that the DUT is correctly connected to the 4352B. Also, verify that the power/control voltage output is turned ON on the LCD display information (the measurement setting parameter display or the status notations). If it is OFF, press **DC Power** or **DC Control**, and press **OUTPUT ON off**.

This message is also displayed if a positive DC voltage component (TTL output, etc.) is included in the DUT's output signal. In this case, insert a high-pass filter to sufficiently eliminate the positive DC voltage component.

–161 **Invalid block data**

A block data element was expected, but was invalid for some reason (see IEEE 488.2, 7.7.6.2). For example, an END message was received before the length was satisfied.

–141 **Invalid character data**

Either the character data element contains an invalid character or the particular element received is not valid for the header.

–121 **Invalid character in number**

An invalid character for the data type being parsed was encountered. For example, an alpha character in a decimal numeric or a “9” in octal data.

–101 **Invalid character**

A syntax element contains a character that is invalid for that type. For example, a header containing an ampersand (SING&).

171 **INVALID DATE**

The date entered to set the real time clock is invalid. Re-enter the correct date.

Error Messages (Alphabetical Order)

50 Invalid Dev Cal

The correction coefficient of the FM deviation calibration is not proper.

Adjustment or repair is necessary. Contact our service office or the company from which you purchased the 4352B.

130 INVALID FILE NAME

The file name for the RECALL, PURGE, or RE-SAVE function must have a “_D” or “_S” extension for LIF format.

–103 Invalid separator

The parser was expecting a separator and encountered an illegal character (semicolon (;), comma (,), etc.).

–151 Invalid string data

A string data element was expected, but was invalid for some reason (see IEEE 488.2, 7.7.5.2). For example, an END message was received before the terminal quote character.

–131 Invalid suffix

The suffix does not follow the syntax described in IEEE 488.2, 7.7.3.2, or the suffix is inappropriate for the 4352B.

133 LIF-DOS COPY NOT ALLOWED

Indicates that you tried to copy a file between the differently formatted disks.

For example, if you try to copy a file between the RAM disk and the flexible disk when the format of the RAM disk is different from the format of the flexible disk, this message is displayed.

–250 MASS STORAGE ERROR

Indicates that a mass storage error occurred. This error message might be displayed if the 4352B detects an unknown problem related to error –257.

–311 Memory error

An error was detected in the 4352B's memory.

–109 Missing parameter

Fewer parameters were received than required for the header.

116 NO ACTIVE MARKER

Indicates that the Marker→ function was executed when no marker is activated. Press Menu **MARKER** to activate a marker.

111 NO DATA TRACE

Indicates that **MKR ON [DATA]** was pressed when no data trace is displayed.

Error Messages (Alphabetical Order)

137 NO DATA TRACE DISPLAYED

Indicates that `SCALE FOR [DATA]` was pressed when no data trace is displayed.

118 NO FIXED DELTA MARKER

The fixed Δ marker was not turned on. Be sure to turn the fixed Δ marker on before using `FIXED Δ MKR VALUE` or `FIXED Δ MKR AUX VALUE`.

114 NO MARKER DELTA - RANGE NOT SET

Indicates that `MKR Δ SEARCH RNG` was selected when the Δ marker is not turned on.

113 NO MARKER DELTA - SPAN NOT SET

Indicates that `MKR Δ SPAN` was selected when the Δ marker is not displayed.

112 NO MEMORY TRACE

Indicates that `MKR ON [MEMORY]` was selected when no memory trace is displayed.

138 NO MEMORY TRACE DISPLAYED

Indicates that `SCALE FOR [MEMORY]` was selected when no memory trace is displayed.

131 NO STATE/DATA FILES ON DISK

There are no files with extensions (“_D” or “_S” for LIF format, or “.STA” or “.DTA” for DOS format) on the flexible disk.

134 NO STATE/DATA FILES ON MEMORY

There are no files with extensions (“_D” or “_S” for LIF format, or “.STA” or “.DTA” for DOS format) in the RAM disk memory.

30 NO VALID MEMORY STORED

Indicates that you tried to display memory trace/data when there was no measurement data stored in memory.

0 (No error)

The error queue is empty. Every error in the queue has been read (OUTPERRO? query) or the queue was cleared by power-on or the *CLS command.

55 Noise Overload

The noise level during a C/N ratio measurement or a phase noise measurement is too large.

This is caused by either the DUT's noise level being too large or by a spurious DUT component being too large in the measurement range. Verify the spectrum of the DUT's output signal.

91 NOT ENOUGH DATA

The amount of data sent to the 4352B is less than that expected when the data transfer format is binary.

Error Messages (Alphabetical Order)

–120 Numeric data error

This error, as well as errors –121 through –129, are generated when parsing a data element that appears to be numeric, including the nondecimal numeric types. This error message might be displayed if the 4352B detects an unknown problem.

–128 Numeric data not allowed

A legal numeric data element was received, but the 4352B does not accept it in this position for a header.

75 POWER FAILED ON *nnn*

Serious error. Contact your nearest Agilent Technologies office. One or more power supply failed. where *nnn* is one of –5 V, –15 V, +5 V, +15 V, +65 V, and PostRegHot. It shows which power line failed. When this error occurs, the system halts so an external controller cannot read this error using GPIB.

22 PRINTER: not on, not connect, wrong address

Indicates that the printer did not respond when the 4352B tried to access the printer via GPIB. Verify power to the printer, and check the GPIB connection between the 4352B and the printer. Ensure that the printer address recognized by the 4352B matches the GPIB address set on the printer itself.

–108 Parameter not allowed

More parameters were received than expected for the header. For example, the *SRE command only accepts one parameter, so receiving *SRE 4,16 is not allowed.

–284 Program currently running

Certain operations dealing with programs may be illegal while the program is running. For example, deleting a running program might not be possible.

–280 Program error

Indicates that a downloaded program-related execution error occurred. This error message might be displayed if the 4352B detects an unknown problem related to errors –281 through –289.

–112 Program mnemonic too long

The header contains more than twelve characters (see IEEE 488.2, 7.6.1.4.1).

–286 Program runtime error

A program runtime error of the HP Instrument BASIC has occurred. To get more specific error information, use the ERRM\$ or ERRM command (HP Instrument BASIC).

–285 Program syntax error

Indicates that a syntax error appears in a downloaded program. The syntax used when parsing the downloaded program is device-specific.

Error Messages (Alphabetical Order)

–350 **Queue overflow**

A specific code entered into the queue instead of the code that caused the error. This code indicates that there is no room in the queue and an error occurred but was not recorded.

–400 **Query error**

This is the generic query error that the 4352B displays when it cannot detect more specific errors. This code indicates only that a query error as defined in IEEE 488.2, 11.5.1.1.7 and 6.3 has occurred.

–410 **Query INTERRUPTED**

A condition causing an interrupted query error occurred (see IEEE 488.2, 6.3.2.3). For example, a query followed by DAB or GET before a response was completely sent.

–420 **Query UNTERMINATED**

A condition causing an unterminated query error occurred (see IEEE 488.2, 6.3.2.2). For example, the 4352B was addressed to talk and an incomplete program message was received by the controller.

129 **RECALL ERROR: INSTR STATE PRESET**

A serious error, for example corrupted data, is detected on recalling a file, and this forced the 4352B to be PRESET.

49 **RF Freq Out Of Range**

The DUT's output frequency is not within the measurement range of the 4352B (10 MHz to 3 GHz).

Verify the DUT's output frequency.

58 **RF Input Over Trans Max Freq**

Indicates that the frequency transient measurement trace was probably inaccurate because the input frequency to the 4352B was above the upper limit of the detection band.

Note, however, that "RF Input Under Trans Min Freq" (message No.: 57) may erroneously appear even when the above problem is present, if the 4352B is operating in the heterodyne mode and if the difference between input signals from the device and the external signal generator is larger than 40 MHz.

Verify that the DUT generates the proper signal, and sends it to the 4352B RF IN connector. If the signal is generated, check its frequency. Press **Sense Range**, **MAX TRANS FREQ** or **MIN TRANS FREQ**, and the entry keys to change the detection bandwidth, if required.

57 **RF Input Under Trans Min Freq**

Indicates that the frequency transient measurement trace was probably inaccurate because the input frequency to the 4352B was below the lower limit of the detection band.

Note, however, that "RF Input Under Trans Max Freq" (message No.: 58) may erroneously appear even when the above problem is present, if the 4352B is operating in the heterodyne mode and if the difference between input signals from the device and the external signal generator is larger than 40 MHz.

Error Messages (Alphabetical Order)

Verify that the DUT generates the proper signal, and inputs it to the 4352B RF IN connector. If the signal is generated, check its frequency. Press **(Sense Range)**, **MAX TRANS FREQ** or **MIN TRANS FREQ**, and the entry keys to change the detection bandwidth, if required.

78 **RF Level Overload**

The input level to the 4352B RF IN connector is too high (+20 dBm or more).

Verify the input level to the 4352B RF IN connector. Also, this message is displayed if a negative DC voltage component is included in the DUT's output signal during RF Power Level measurement. In this case, insert a filter between the DUT's output terminal and the 4352B RF IN connector to eliminate the DC voltage component.

Caution Continuously applying excessive input to the 4352B will cause failures.



128 **SAVE ERROR**

A serious error occurred while a file was being saved.

For example, this is displayed when the disk surface is physically damaged.

27 **SG:not on, not connect, wrong address**

Indicates that the external signal generator did not respond when the 4352B tried to control the external signal generator via GPIB.

Verify the external signal generator is turned ON, the GPIB cable connection is proper, the GPIB address setting for the external signal generator is proper, etc.

-330 **Self-test failed**

The self test failed. Either contact our service office, or see the *Service Manual*.

47 **Set Noise ATT 10 dB More**

Press **(Sense Range)**, **NOISE ATTN**, and the entry keys to set a value 10 dB higher than the current setting.

41 **Set RF ATT 5 dB Less**

Press **(Sense Range)**, **RF ATTN**, and the entry keys to set a value 5 dB lower than the current setting.

42 **Set RF ATT 5 dB More**

Press **(Sense Range)**, **RF ATTN**, and the entry keys to set a value 5 dB higher than the current setting.

-221 **Settings conflict**

A legal program data element was parsed but could not be executed due to the current device state (See IEEE 488.2, 6.4.5.3, and 11.5.1.1.5.).

Error Messages (Alphabetical Order)

–150 **String data error**

This error, as well as errors –151 and –158, are generated when analyzing the syntax of a string data element. This error message might be displayed if the 4352B detects an unknown problem.

–158 **String data not allowed**

A string data element was encountered but was not allowed by the 4352B at this point in parsing.

–130 **Suffix error**

This error, as well as errors –131 through –139, are generated when parsing a suffix. This error message might be displayed if the 4352B detects an unknown problem.

–138 **Suffix not allowed**

A suffix was encountered after a numeric element that does not allow suffixes.

–134 **Suffix too long**

The suffix contained more than 12 characters (see IEEE 488.2, 7.7.3.4).

–102 **Syntax error**

An unrecognized command or data type was encountered. For example, a string was received when the 4352B was not expecting to receive a string.

–310 **System error**

Some error, termed “system error” by the 4352B, has occurred.

59 **Target Freq Out Of Range**

Indicates the 2nd or 3rd harmonic target frequency is not within the 4352B measurement range (below 10 MHz or above 3 GHz) when `2xCARR → CENTER` or `3 x CARR → CENTER` is selected in spectrum measurements.

At this time, the previous measurement conditions still remain [any of the sweep parameters (start, stop, center, or span values) are not changed]. Check the DUT's output frequency.

90 **TOO MUCH DATA**

Either there is too much binary data to send to the 4352B when the data transfer format is FORM 2, FORM 3 or FORM 5, or the amount of data is greater than the number of points.

82 **Thermometer Out Of Range**

The 4352B's internal thermometer reading is out of the proper range.

Adjustment or repair is necessary. Contact our service office or the company from which you purchased the 4352B.

Error Messages (Alphabetical Order)

–124 Too many digits

The mantissa of a decimal numeric data element contains more than 255 digits excluding leading zeros (see IEEE 488.2, 7.7.2.4.1).

–223 Too much data

A legal program data element of block, expression, or string type was received that contained more data than the 4352B could handle due to memory or related device-specific requirements.

–210 Trigger error

A trigger related error occurred. This error message might be displayed if the 4352B detects an unknown problem related to errors –211 through –219.

–211 Trigger ignored

A GET, *TRG, or triggering signal was received and recognized by the 4352B but was ignored because of the 4352B timing considerations. For example, the 4352B was not ready to respond.

–113 Undefined header

The header is syntactically correct, but it is undefined for the 4352B. For example, *XYZ is not defined for the 4352B.

160 WRONG I/O PORT DIRECTION

The direction setting for the I/O port (input or output) is incorrect.

Verify that a signal from an external instrument is being sent to an input port, and a signal from an output port is being sent to an external instrument.

79 X-tal PLL Unlocked (40 MHz)

The 4352B's internal PLL cannot be locked.

Verify the reference frequency input to the EXT REF input connector on the 4352B rear panel is 10 MHz \pm 100 Hz.

80 X-tal PLL Unlocked (85.6 MHz)

The 4352B's internal PLL cannot be locked.

Adjustment or repair is necessary. Contact our service office or the company from which you purchased the 4352B.

Error Messages in Numerical Order

Note



The positive number error messages are listed first, and then negative number error messages are listed.

- 0 (No error)
- 13 **BACKUP DATA LOST**
- 22 **PRINTER: not on, not connect, wrong address**
- 27 **SG: not on, not connect, wrong address**
- 30 **NO VALID MEMORY STORED**
- 40 **Insufficient RF Level**
- 41 **Set RF ATT 5 dB Less**
- 42 **Set RF ATT 5 dB More**
- 43 **F-V Input Underflow**
- 44 **F-V Input Overflow**
- 45 **1st IF Out Of Range**
- 47 **Set Noise ATT 10 dB More**
- 48 **AFC Out Of Loop**
- 49 **RF Freq Out Of Range**
- 50 **Invalid Dev Cal**
- 51 **Calibration Aborted**
- 52 **DC Output On Required in AFC**
- 53 **FM Deviation Range Overload**
- 54 **Carrier Overload**
- 55 **Noise Overload**

Error Messages (Numerical Order)

- 57 **RF Input Under Trans Min Freq**
- 58 **RF Input Over Trans Max Freq**
- 59 **Target Freq Out Of Range**
- 70 **A/D Overload**
- 75 **POWER FAILED ON *nnn***
- 76 **DC Power Current Overload**
- 77 **DC Control Current Overload**
- 78 **RF Level Overload**
- 79 **X-tal PLL Unlocked (40 MHz)**
- 80 **X-tal PLL Unlocked (85.6 MHz)**
- 81 **2nd PLL Unlocked**
- 82 **Thermometer Out Of Range**
- 90 **TOO MUCH DATA**
- 91 **NOT ENOUGH DATA**
- 100 **CAN'T CHANGE- ANOTHER CONTROLLER ON BUS**
- 102 **ANALYZER TYPE MISMATCH**
- 111 **NO DATA TRACE**
- 112 **NO MEMORY TRACE**
- 113 **NO MARKER DELTA - SPAN NOT SET**
- 114 **NO MARKER DELTA - RANGE NOT SET**
- 116 **NO ACTIVE MARKER**
- 118 **NO FIXED DELTA MARKER**
- 128 **SAVE ERROR**
- 129 **RECALL ERROR: INSTR STATE PRESET**

Error Messages (Numerical Order)

- 130 **INVALID FILE NAME**
- 131 **NO STATE/DATA FILES ON DISK**
- 132 **CAN'T SAVE GRAPHICS WHEN COPY IN PROGRESS**
- 133 **LIF-DOS COPY NOT ALLOWED**
- 134 **NO STATE/DATA FILES ON MEMORY**
- 135 **DUPLICATE FILE EXTENSION**
- 137 **NO DATA TRACE DISPLAYED**
- 138 **NO MEMORY TRACE DISPLAYED**
- 144 **CAN'T CHANGE NUMBER OF POINTS**
- 159 **INSUFFICIENT memory**
- 160 **WRONG I/O PORT DIRECTION**
- 171 **INVALID DATE**
- 230 **FLOPPY DISK DRIVE FAILURE FOUND**

- 100 **Command error**
- 101 **Invalid character**
- 102 **Syntax error**
- 103 **Invalid separator**
- 104 **Data type error**
- 105 **GET not allowed**
- 108 **Parameter not allowed**
- 109 **Missing parameter**
- 110 **Command header error**
- 111 **Header separator error**
- 112 **Program mnemonic too long**

Error Messages (Numerical Order)

- 113 **Undefined header**
- 114 **Header Suffix out of range**
- 120 **Numeric data error**
- 121 **Invalid character in number**
- 123 **Exponent too large**
- 124 **Too many digits**
- 128 **Numeric data not allowed**
- 130 **Suffix error**
- 131 **Invalid suffix**
- 134 **Suffix too long**
- 138 **Suffix not allowed**
- 140 **Character data error**
- 141 **Invalid character data**
- 144 **Character data too long**
- 148 **Character data not allowed**
- 150 **String data error**
- 151 **Invalid string data**
- 158 **String data not allowed**
- 160 **Block data error**
- 161 **Invalid block data**
- 168 **Block data not allowed**
- 200 **Execution error**
- 210 **Trigger error**
- 211 **Trigger ignored**

Error Messages (Numerical Order)

- 213 **Init ignored**
- 220 **Parameter error**
- 221 **Settings conflict**
- 222 **Data out of range**
- 223 **Too much data**
- 224 **Illegal parameter value**
- 225 **Data out of memory**
- 230 **Data corrupt or stale**
- 231 **Data questionable**
- 240 **Hardware error**
- 241 **Hardware missing**
- 250 **MASS STORAGE ERROR**
- 257 **FILE NAME ERROR**
- 280 **Program error**
- 281 **Cannot create program**
- 282 **Illegal program name**
- 283 **Illegal variable name**
- 284 **Program currently running**
- 285 **Program syntax error**
- 286 **Program runtime error**
- 310 **System error**
- 311 **Memory error**
- 330 **Self-test failed**
- 350 **Queue overflow**

Error Messages (Numerical Order)

–400 **Query error**

–410 **Query INTERRUPTED**

–420 **Query UNTERMINATED**