

## 17 Functional Tests

### Functional Test Performance Verification

Functional tests are tests of various instrument parameters that give a high degree of confidence that the analyzer is operating correctly. They are recommended as a check of analyzer operation for incoming inspection or after a repair. Measurement uncertainty analysis is not available for functional tests, and the analyzer is checked against limits that are wider than the published specifications. The functional tests are designed to test an analyzer operating within the temperature range defined by the analyzer specifications using a minimum set of test equipment. If a test does not pass, performance verification tests must be run to determine whether a problem exists.

Functional tests use a minimum set of test equipment to check a much smaller range of parameters (and a limited number of data points for each parameter) than do performance verification tests. Functional tests use limits that are wider than the published specifications; measurement uncertainty analysis is **not** available for functional tests.

#### NOTE

**If a functional test does not pass, you must run performance verification tests to determine whether a problem exists.**

---

Performance verification tests span a wide range of instrument parameters and provide the highest level of confidence that the instrument conforms to published specifications. These tests can be time consuming and require extensive test equipment.

## Before Performing a Functional Test

1. Ensure that you have the proper test equipment.
2. Switch on the unit under test (UUT) and let it warm up (in accordance with warm-up requirements in the instrument specifications).
3. Allow sufficient warm-up time for the required test equipment (refer to individual instrument documentation for warm-up specifications).
4. Ensure that the analyzer's frequency reference is set to **Internal**:
  - a. Press the **Input/Output**, **Freq Ref Input** keys.
  - b. If the **Freq Ref Input** does **not** show **Internal**, press the **Freq Ref Input** softkey and select **Internal**.
5. Following instrument warm-up, perform the auto align routine:  
Press **System**, **Alignments**, **Align Now**, **Align Now All**.

### NOTE

Functional test accuracy depends on the precision of the test equipment used. Ensure that all of the test equipment is calibrated before running a functional test.

---

## Test Equipment

The table below summarizes the test equipment needed to perform all of the functional tests. Alternate equipment model numbers are given in case the recommended equipment is not available. If neither the recommended nor the alternative test equipment are available, substitute equipment that meets or exceeds the critical specifications listed.

Table 17-1

Analyzer Option	Item	Critical Specifications	Recommended Keysight Model	Alternate Keysight Model
<b>Adapters</b>				
503, 507, 513, 526	3.5 mm (f) to 3.5 mm (f) (connector saver for source)	Frequency: 10 MHz to 26.5 GHz VSWR: < 1.1:1	83059B	1250-1749
532, 544, 550	2.4 mm (f) to 2.4 mm (f)	Frequency: 10 MHz to 50 GHz VSWR: < 1.1:1	11900B	
532, 544, 550	2.4 mm (f) to 3.5 mm (f) (connector saver for source)	Frequency: 10 MHz to 26.5 GHz VSWR: < 1.1:1	11901B	
All	BNC (f) to SMA (m)	Frequency: 40 MHz	1250-1200	
All	Type N (f) to Type N (f)	Frequency: 10 MHz to 18 GHz VSWR: < 1.05:1	1250-1472	1250-0777
All	Type N (m) to 3.5 mm (m)	Frequency: 10 MHz to 18 GHz VSWR: < 1.1:1	1250-1743	
All	Type N (m) to 3.5 mm (f)	Frequency: 10 MHz to 18 GHz VSWR: < 1.1:1	1250-1744	
All	Type N (f) to 3.5 mm (f)	Frequency: 10 MHz to 18 GHz VSWR: < 1.1:1	1250-1745	
All	Type N (m) to BNC (f)	Frequency: 10 MHz to 1 GHz VSWR: < 1.05:1	1250-1476	
<b>Attenuators</b>				
All	10 dB Step Attenuator	Frequency: 50 MHz Range: 0 to 70 dB	8495A	8496A
All	10 dB Fixed Attenuator (2 required)	Frequency: 50 MHz VSWR: < 1.2:1	8493C Option 010	8493A Option 010 or 8493B Option 010

Functional Tests  
Test Equipment

Table 17-1

Analyzer Option	Item	Critical Specifications	Recommended Keysight Model	Alternate Keysight Model
Preamp Options (Pxx)	30 dB Fixed Attenuator	Accuracy: < 0.05 dB @ 50 MHz	11708A	
<b>Cables</b>				
All	3.5 mm (1 meter)	Frequency: 10 MHz to 26.5 GHz VSWR: < 1.4:1 Loss: < 2.0 dB	11500E	8120-4921
532, 544, 550	2.4 mm (f) to 2.4 mm (m) (1 meter)	Frequency: 10 MHz to 50 GHz VSWR: < 1.55:1 @ 44 GHz Loss: < 6.0 dB	8120-6164	
All	Cable, BNC (3 required)	120 cm (48 in.) BNC cable	10503A	
BBA	Cable, BNC	120 cm (48 in.) BNC cable Flatness (250 kHz to 40 MHz) < 0.5 dB	10503A	
BBA	Cable, BNC	BNC male 23 cm (9 in) max	10502A	
<b>Signal Source</b>				
All	Synthesized Sweeper	Frequency: 10 MHz to 44 GHz <sup>a</sup> Harmonic level: < - 40 dBc Amplitude: 10 to - 20 dBm Frequency Accuracy: 0.02%	PSG <sup>b</sup>	83630B, 83640B, 83650B
BBA	Signal Generator	Frequency: 250 kHz to 40 MHz Amplitude: ~-10 dBm Flatness: < ±0.75 dB	E4438C	33250A
<b>Power Meter</b>				
All	Power Meter	Power Reference Accuracy: ±1.2% Compatible with power sensor	E4418B	E4419B
All	Power Sensor	Frequency: 50 MHz to 3.66 GHz Amplitude: -70 to -10 dBm	8481D	8487D 8485D
503, 508, 513	Power Sensor	Frequency: 50 MHz to 13.66 GHz Amplitude: -30 to +20 dBm	8481A	N8481A
526	Power Sensor	Frequency: 50 MHz to 26.5 GHz Amplitude: -30 to +20 dBm	8485A	N8485A
532, 544, 550	Power Sensor	Frequency: 50 MHz to 50 GHz <sup>c</sup> Amplitude: -30 to +20 dBm	8487A	

Functional Tests  
Test Equipment

Table 17-1

Analyzer Option	Item	Critical Specifications	Recommended Keysight Model	Alternate Keysight Model
P03	Low Power Sensor	Frequency: 50 MHz to 3.6 GHz Amplitude: -70 to -10 dBm	8481D	8485D 8487D
Pxx other than P03	Low Power Sensor	Frequency: 50 MHz to 50 GHz <sup>C</sup> Amplitude: -70 to -10 dBm	8487D	
<b>Miscellaneous Equipment</b>				
All	Filter, 50 MHz Low Pass	Cutoff Frequency: 50 MHz Rejection at 65 MHz: > 40 dB Rejection at 75 MHz: > 60 dB Rejection at 80 MHz: > 60 dB	0955-0306	
526	Power Splitter, 3.5 mm	Nominal Insertion Loss: 6 dB Tracking Between Ports: < 0.25 dB	11667B	
532, 544, 550	Power Splitter	Nominal Insertion Loss: 8.5 dB Tracking Between Ports: < 0.4 dB	11667C	
503, 508, 513	Power Splitter	Nominal Insertion Loss: 6 dB Tracking Between Ports: < 0.25 dB	11667A	11667B
All	Termination, 50Ω	Type N (m) Connector Frequency: 30 Hz to 26.5 GHz	909A Option 012	
532, 544, 550	Termination, 50Ω	2.4 mm (f) Connector Frequency: 9 kHz to 44 GHz	85138B	

- a. Maximum frequency equal to or greater than the maximum frequency of the MXA.
- b. PSG model numbers: E8244A, E8254A, E8247C Option 520, E8247C Option H31 or 540, E8257D Option 520, E8257D Option 550, E8257D Option 567, E8267D Option 544.
- c. Maximum frequency equal to or greater than the maximum frequency of the preamplifier option.

## Displayed Average Noise Level (DANL)

### Test Limits (with 0 dB input attenuation)

See [Table 17-2](#) for values.

The Displayed Average Noise Level (DANL) of the signal analyzer is measured across a 10 kHz frequency span at several center frequencies. The analyzer input is terminated into a 50  $\Omega$  load. A test is performed to assure the measurement is not performed in the presence of a residual response. The measurement is then averaged, and the result is normalized to a 1 Hz bandwidth.

Table 17-2 DANL Measurement Requirements

Item	Critical Specifications (for this test)	Recommended Keysight Model
Termination, 50 $\Omega$ Type-N (m) <sup>a</sup>	Frequency: 10 MHz to 18 GHz	909A Option 012
Termination, 50 $\Omega$ 2.4 mm (f) <sup>b</sup>	Frequency: 10 MHz to 50 GHz	85138B

a. For Options 503, 507, 513, and 526

b. For Options 532, 544, and 550

Figure 17-1 DANL Test Setup

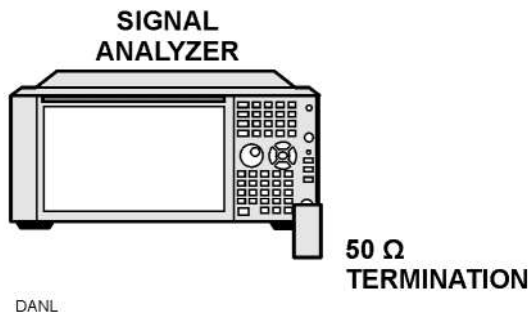

### Procedure

1. Configure the equipment as shown in [Figure 17-1](#)
2. Press **MODE/MEAS**. Select **Spectrum Analyzer** mode, **Swept SA** measurement, **Normal** view. Press **OK**. Press **Mode Preset** on the analyzer.
3. Set up the signal analyzer by pressing:

**FREQ, Center Frequency, 10, MHz**  
**Input/Output, Input, RF Coupling, select DC**  
**FREQ, Span, 10, kHz**  
**AMPTD, -70, dBm**  
**AMPTD, Attenuation, Mech Atten, 0, dB**

**BW, Res BW, 1, kHz**  
**BW, Video BW, 100, Hz**  
**Meas Setup, Avg/Hold, Number, 20, Enter**  
**Trace, Trace Average**  
**Single/Cont** until single sweep is selected.

4. Press **Restart**, then wait for Average/Hold to display 20/20.
5. Press **Display, Meas Display**, then press **Display Line, On**.
6. Rotate the knob and set the display line at the average amplitude of the displayed noise floor by visual inspection.
7. Confirm that the measurement is performed on the analyzer noise floor and not on a residual response within the displayed 10 kHz span.

**NOTE**

Ignore the residual response if one appears when taking the measurement.

- 
8. Enter the value of the display line as the Measured Average Noise Level at 10 MHz column in [Table 17-2 on page 586](#).
  9. Normalize the measured value to a 1 Hz BW by adding -30 dB to the measured value.

**NOTE**

The -30 dB value is added because the formula used to calculate the value of the noise power in a 1 Hz BW when measured with a 1 kHz BW is:

Normalized Noise = 10 Log (BW 2/BW 1) where BW 2 is the 1 kHz BW we measure and BW 1 is 1 Hz BW to which we want to normalize.

Therefore, 10 Log (1000) = 30 dB, so the noise floor will be 30 dB lower in a 1 Hz BW.

- 
10. Enter the normalized value of the displayed average noise level in [Table 17-2 on page 586](#).
  11. The value of the normalized displayed average noise should be less than the specification value.
  12. Change the analyzer center frequency to the next value listed in [Table 17-2 on page 586](#). Press: **FREQ, Center Frequency**, [Table 2-1 Value], **GHz**
  13. Repeat [step 4](#) through [step 12](#) to fill in the remainder of [Table 17-2 on page 586](#) for your analyzer frequency range.

Functional Tests  
 Displayed Average Noise Level (DANL)

<b>Center Frequency</b>	<b>Measured Average Noise Level (dBm)</b>	<b>Normalized Average Noise Level/(1 Hz BW) (dBm)</b>	<b>Test Limits (dBm) (Options 503, 508, 513, 526)</b>	<b>Test Limits (dBm) (Options 532, 544, 550)</b>
10 MHz			-150	-150
2 GHz			-150	-151
6 GHz			-148	-142
13 GHz			-147	-145
20 GHz			-142	-138
26.5 GHz			-135	-138
30 GHz			N/A	-136
35 GHz			N/A	-133
40 GHz			N/A	-131
43.5 GHz			N/A	-131
50 GHz			N/A	-127

## Frequency Readout Accuracy

### Test Limits

Frequency Readout Accuracy is equivalent to the following equation:

$$\pm(0.25\% \times \text{span} + 5\% \times \text{RBW} + 2 \text{ Hz} + 0.5 \times \text{horizontal resolution})$$

See results table for actual values.

The frequency readout accuracy is measured in several spans and center frequencies that allow both internal analyzer synthesizer modes and prefilter bandwidths to be tested. Frequency reference error is eliminated by using the same frequency standard for the analyzer and signal source.

Item	Critical Specification (for this test)	Recommended Keysight Model
Adapter, Type-N (m), to 3.5 mm (f)	Frequency: 10 MHz to 1.51 GHz VSWR: < 1.1:1	1250-1744
Adapter, 3.5 mm (f) to 3.5 mm (f)	Frequency: 10 MHz to 1.51 GHz VSWR: < 1.1:1	83059B
Cable, 3.5 mm, 1 meter	Frequency: 10 MHz to 1.51 GHz VSWR: < 1.4:1	11500E
Cable, BNC, 120 cm	Frequency: 10 MHz	10503A
Synthesized Sweeper	Frequency: 10 MHz to 1.51 GHz	PSG

Figure 17-2 Frequency Readout Accuracy Test Setup

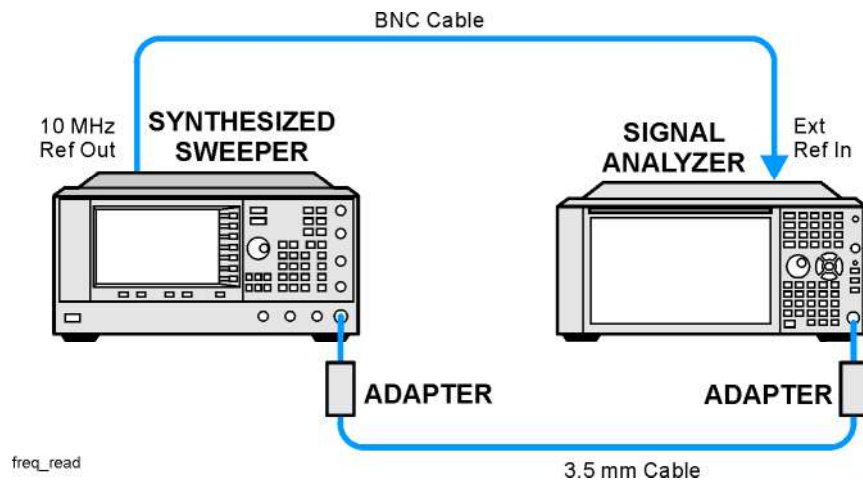

### Procedure

1. Configure the equipment as shown in **Figure 17-2**. Confirm the analyzer's built-in auto alignment has been performed within the past 24 hours.

- On the synthesized sweeper, press **PRESET**, then set the controls as follows:

**FREQUENCY, 1505, MHz**  
**POWER LEVEL, -10, dBm**

- Set up the signal analyzer by pressing:

**MODE/MEAS.** Select **Spectrum Analyzer** mode, **Swept SA** measurement, **Normal** view. Press **OK**. Press **Mode Preset Input/Output, Freq Ref Input, Freq Ref Input External**  
**FREQ, Center Frequency, 1505, MHz**  
**Span, 2990, MHz**  
**Trace, Detector, Sample**  
**Single/Cont** to place analyzer in Single Sweep.

- Press **Restart**.

Press **Peak Search** on the analyzer. If the instrument is functioning correctly, the marker reading in the active function block will be between the values listed in [Table 17-3](#). Record the marker value in the Marker Frequency Readout column in [Table 17-3](#).

- On the signal analyzer, change the span and center frequency as listed in [Table 17-3](#).
- Change the synthesized sweeper frequency to match the center frequency of the analyzer.
- Repeat [step 4](#) through [step 6](#) until the Marker Frequency Readout column of [Table 17-3](#) is complete.

Table 17-3 Frequency Readout Accuracy Results

Span (MHz)	Center Frequency (MHz)	Minimum	Marker Frequency Readout	Maximum
2990	1505	1495.9 MHz		1514.1 MHz
127.2	1505	1504.56 MHz		1505.44 MHz
54.1	1505	1504.8122 MHz		1505.1878 MHz
7.95	1505	1504.97240 MHz		1505.0276 MHz
0.106	1505	1504.999630 MHz		1505.000370 MHz
1.98	517.59	517.58316 MHz		517.59684 MHz
1.98	832.50	832.49316 MHz		832.50684 MHz

## Second Harmonic Distortion (SHD)

### Test Limits

Applied Frequency	Mixer Level	Distortion
40 MHz	-10 dBm	< -55 dBc

This test checks the second harmonic distortion of the signal analyzer by tuning to twice the input frequency and examining the level of the distortion product. A low pass filter is inserted between the source and the signal analyzer to prevent the source second harmonic from artificially raising the second harmonic product displayed on the analyzer.

The power level at the input mixer is 20 dB higher than specified to allow the distortion product to be seen. For example, the instrument specification may state that with a -15 dBm signal at the input mixer, the distortion product should be suppressed by > -60 dBc.

The equivalent Second Harmonic Intercept (SHI) is 45 dBm (-15 dBm + 60 dBc). This test is performed with -10 dBm at the mixer and verifies the distortion product is suppressed by -55 dBc. This ensures the SHI is also 45 dBm (-10 dBm + 55 dBc).

Item	Critical Specifications (for this test)	Recommended Keysight Model
Adapter, Type-N(m) to BNC(f)	Frequency: 10 MHz to 80 MHz VSWR: < 1.05:1	1250-1476
Adapter, BNC(f) to SMA(m)	Frequency: 40 to 80 MHz	1250-1200
Adapter, 3.5 mm(f) to 3.5 mm(f)	Frequency: 10 MHz to 80 MHz VSWR: < 1.1:1	83059B
Cable, BNC 120 cm (2 required)	Frequency: 10 to 40 MHz	10503A
Filter, 50 MHz Low Pass	Cutoff Frequency: 50 MHz Rejection at 65 MHz: > 40 dB Rejection at 75 MHz: > 60 dB	0955-0306
Synthesized Sweeper	Frequency: 50 MHz Spectral Purity: Better than -30 dBc	PSG

Figure 17-3

Second Harmonic Distortion Test Setup

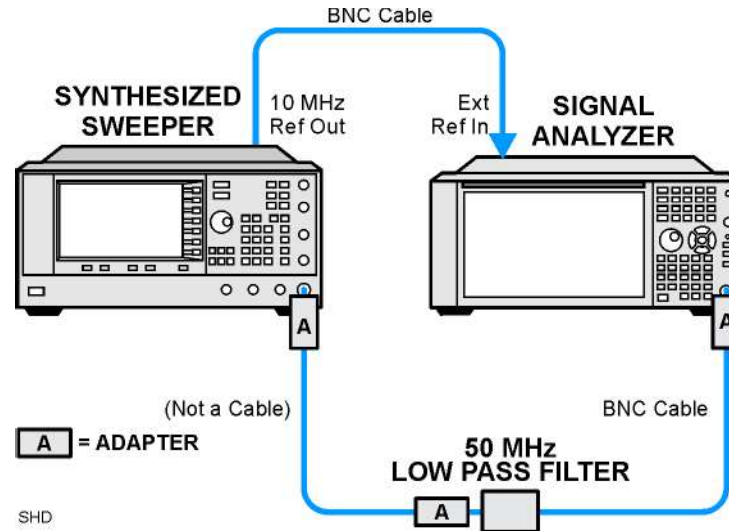

### Procedure

1. Configure the equipment as shown in [Figure 17-3](#).
2. Press **MODE/MEAS**. Select the **Spectrum Analyzer** mode, **Swept SA** measurement, and **Normal** view. Press **OK**. Press **Mode Preset**.
3. Set up the synthesized sweeper by pressing:  
**Frequency, 40, MHz**  
**Amplitude, -10, dBm**
4. Set up the signal analyzer by pressing:  
**Input/Output, Freq Ref Input, Freq Ref Input External**  
**FREQ, Center Frequency 40, MHz**  
**Span, 1, MHz**
5. On the analyzer, press **Peak Search**.
6. Adjust the synthesized sweeper amplitude for a signal analyzer display of  $-10 \text{ dBm} \pm 0.1 \text{ dB}$ .
7. On the analyzer, activate the marker delta function by pressing the **Marker** and **Delta** keys.
8. On the signal analyzer, press:  
**FREQ, Center Frequency, 80, MHz**  
**Meas Setup, Avg/Hold Number, 20, Enter**  
**Trace, Trace Average**  
**Single**

Functional Tests  
Second Harmonic Distortion (SHD)

9. Press **Peak Search**. Enter the displayed value under the Measured Second Harmonic Distortion (dBc) heading in **Table 17-4**.

Table 17-4 Second Harmonic Distortion Results

Applied Frequency (MHz)	Measured Second Harmonic Distortion (dBc)	Mixer Level (dBm)	Specification (dBc)
40		-10	-55

## Amplitude Accuracy at 50 MHz

### Test Limits

Amplitude Accuracy should remain within 1.13 dB of the measured source value across the range of source levels and changes in resolution bandwidth. The Preamp (option P03, P08, P13, P26) should remain within  $\pm 1.3$  dB of measured values.

A synthesized sweeper is used as the signal source for the test. The source amplitude is varied using the signal source amplitude control. The attenuation and resolution bandwidth are varied on the signal analyzer. The source amplitude is measured by the power meter and signal analyzer at each setting, and the values compared. The difference between each pair of measurements indicates the amplitude accuracy.

Item	Critical Specifications	Recommended Keysight Model
Adapter <sup>a</sup>	Type-N (m), to 3.5 mm (m)	1250-1743
Adapter <sup>a</sup>	3.5 mm (f) to 3.5 mm (f)	83059B
Adapter <sup>b</sup>	2.4 mm (f) to 3.5 mm (m)	11901A
Adapter	2.4 mm (f) to 3.5 mm (f)	11901B
Attenuator, 30 dB	Accuracy: < 0.5 dB at 50 MHz	11708A
Cable	3.5 mm, 1 meter	11500E
Cable	BNC, 120 cm	10503A
Power Meter	Compatible with power sensor	E4418B
Power Sensor	Amplitude: -25 dBm to 10 dBm	8485A
Power Splitter	3.5 mm (f) connectors 6 dB loss	11667B
Synthesized Sweeper	Typical Temperature Stability: 0.01 dBc/°C	PSG

a. For Options 503, 508, 513, and 526

b. For Options 532, 544, and 550

Figure 17-4 Amplitude Accuracy Test Setup

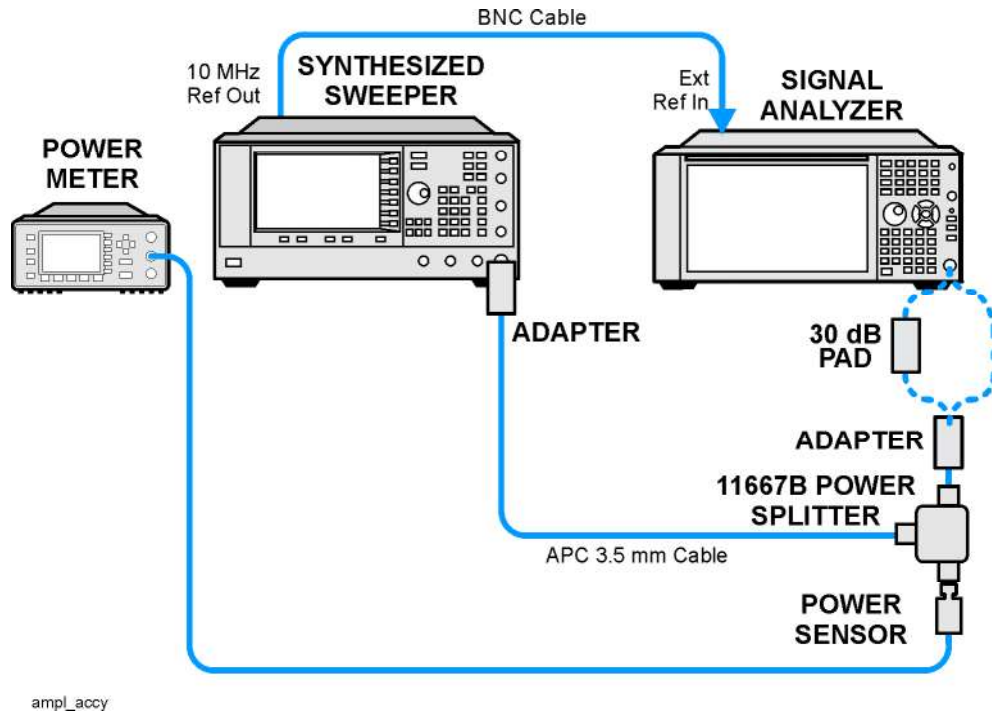

## Procedure

1. Zero and calibrate the power meter.
2. Configure equipment as shown in [Figure 17-4](#), with the power splitter connected directly to the signal analyzer input through the adapter.

### CAUTION

To minimize stress on the test equipment connections, support the power sensor.

3. If the auto alignment for the analyzer has not been performed within the past 24 hours, press **System, Alignments, Align Now, Align Now All** to perform the auto alignment routine.
4. Press **MODE/MEAS**. Select the **Spectrum Analyzer** mode, **Swept SA** measurement, and **Normal** view. Press **OK**. Press **Mode Preset**.
5. Set up the synthesized sweeper by pressing:  
**CW, 50, MHz**  
**Power Level, -4, dBm**  
**RF (On)**
6. Set up the signal analyzer by pressing:  
**Input/Output, Freq Ref Input, Freq Ref Input External**  
**FREQ, Center Frequency, 50, MHz**  
**Span, 2, MHz**

**AMPTD, Attenuation, Mech Atten, 10, dB  
Input/Output, Input, RF Coupling, select DC  
SWEEP, Sweep Config, Sweep Time Rules, SA - Accuracy  
Meas Setup, Avg/Hold Number, 20, Enter  
Trace, Trace Average  
Single**

7. Perform the following steps for each row listed in [Table 17-5](#):
  - a. Set the synthesized sweeper amplitude to the value listed in the Nominal Source Amplitude column in [Table 17-5](#)
  - b. Set the Mech Atten as indicated in the Attenuation column in [Table 17-5](#)
  - c. Set the Span as listed in the Span column of [Table 17-5](#)
  - d. Record the source amplitude, as measured by the power meter, in the Power Meter Amplitude column of [Table 17-5](#)
  - e. On the signal analyzer, press **Restart**.
  - f. Wait for the signal analyzer to finish averaging.
  - g. Press Peak Search.
  - h. Record the signal amplitude, as measured by the analyzer in the Measured Amplitude column of [Table 17-5](#)
  - i. Calculate the signal amplitude accuracy error using the following equation, and record the results under the Amplitude Accuracy Error column:

$$\text{Amplitude Accuracy Error} = \text{Meas\_amp} - \text{Power\_meter}$$

Table 17-5 Amplitude Accuracy Results

Nominal Source Amplitude (dBm)	Attenuation (dB)	Span (MHz)	Measured Amplitude Meas_amp (dBm)	Power Meter Amplitude Power_meter (dBm)	Amplitude Accuracy Error (dB)	Test Limit (dB)
-4	10	2				±1.13 dB
-9	10	1				±1.13 dB
-14	10	0.5				±1.13 dB
-4	20	0.1				±1.13 dB
-14	20	0.1				±1.13 dB
-4	30	0.1				±1.13 dB
-14	30	0.1				±1.13 dB

## Testing Preamp Option (P03, P08, P13, P26, P32, P44, P50)

Instruments containing Options P03, P08, P13, P26 must have the preamp function turned on and tested.

### Procedure

1. On the analyzer, press **AMPTD, Signal Path, Internal Preamp, Low Band**.
2. Connect the equipment as shown in [Figure 17-4 on page 595](#), using a 30 dB Pad between the adapter and the signal analyzer input.
3. Set the synthesized sweeper amplitude to the value listed in the Nominal Source Amplitude column in [Table 17-6](#).
4. Set the signal analyzer input attenuation to 0 dB.
5. Set the Span as listed in [Table 17-6](#).
6. Record the source amplitude, as measured by the power meter, in the Power Meter Amplitude column of [Table 17-6](#).
7. On the signal analyzer, press **Restart**.
8. Wait for the analyzer to finish averaging.
9. Press **Peak Search**.
10. Record the signal amplitude as measured by the analyzer in the measured amplitude column of [Table 17-6](#).
11. Calculate the signal amplitude accuracy using the following equation:  

$$\text{Amplitude Accuracy Error} = \text{Meas\_amp} + 30 \text{ dB} - \text{Power\_meter}$$
12. Record the results under the Amplitude Accuracy Error column of [Table 17-6](#)

Table 17-6 Amplitude Accuracy Results (Option P03, P08, P13, P26, P32, P44, P50)

Nominal Source Amplitude (dBm)	Low- band Preamp	Res BW (kHz)	Span (kHz)	Measured Amplitude Meas_amp (dBm)	Power Meter Amplitude Power_meter (dBm)	Amplitude Accuracy Error (dB)	Test Limit (dB)
-13	ON	1	106				±1.30 dB

## Frequency Response (Flatness)

### Test Limits

Frequency Range	Limit Relative to 50 MHz
20 Hz to 3.6 GHz	±1.5 dB
> 3.6 GHz to 8.4 GHz	±2.5 dB
> 8.4 GHz to 13.6 GHz	±3.0 dB
> 13.6 GHz to 26.5 GHz	±3.5 dB
> 26.5 GHz to 34.5 GHz	±3.5 dB
> 34.5 GHz to 50 GHz	±4.2 dB

The frequency response test measures the signal analyzer's amplitude error as a function of the tuned frequency. Measurements are made ranging from 50 MHz to the maximum frequency range of your analyzer. The signal source amplitude is measured with a power meter to eliminate error due to source flatness. The measured value is normalized to 50 MHz.

Item	Critical Specifications (for this test)	Recommended Keysight Model
Adapter, Type N (m) to 3.5 mm (m)	Frequency: 10 MHz to 18 GHz VSWR: < 1.1:1	1250-1743
Adapter, 3.5 mm (f) to 3.5 mm (f)	Frequency: 10 MHz to 26.5 GHz VSWR: < 1.1:1	83059B
Cable, 3.5 mm, 1 meter	Frequency: 10 MHz to 26.5 GHz VSWR: < 1.4:1	11500E
Cable, 2.4 mm, 1 meter	Frequency: 10 MHz to 50 GHz VSWR: < 1.55:1	8120-6164
Cables, BNC 120 cm	Frequency: 10 MHz	10503A
Power Meter	Compatible with power sensor	E4418B
Power Sensor <sup>a</sup>	Frequency: 50 MHz to 26.5 GHz	8485A
Power Sensor <sup>b</sup>	Frequency: 50 MHz to 50 GHz	8487A
Power Splitter <sup>a</sup>	Frequency: 50 MHz to 26.5 GHz Tracking between ports: < 0.25 dB	11667B

Functional Tests  
 Frequency Response (Flatness)

Item	Critical Specifications (for this test)	Recommended Keysight Model
Power Splitter <sup>b</sup>	Frequency: 50 MHz to 50 GHz Tracking between ports: < 0.4 dB	11667C
Synthesized Sweeper	Frequency: 50 MHz to 50 GHz	PSG

- a. For Options 503, 508, 513, and 526  
 b. For Options 532, 544, and 550

Figure 17-5 Frequency Response Test Setup

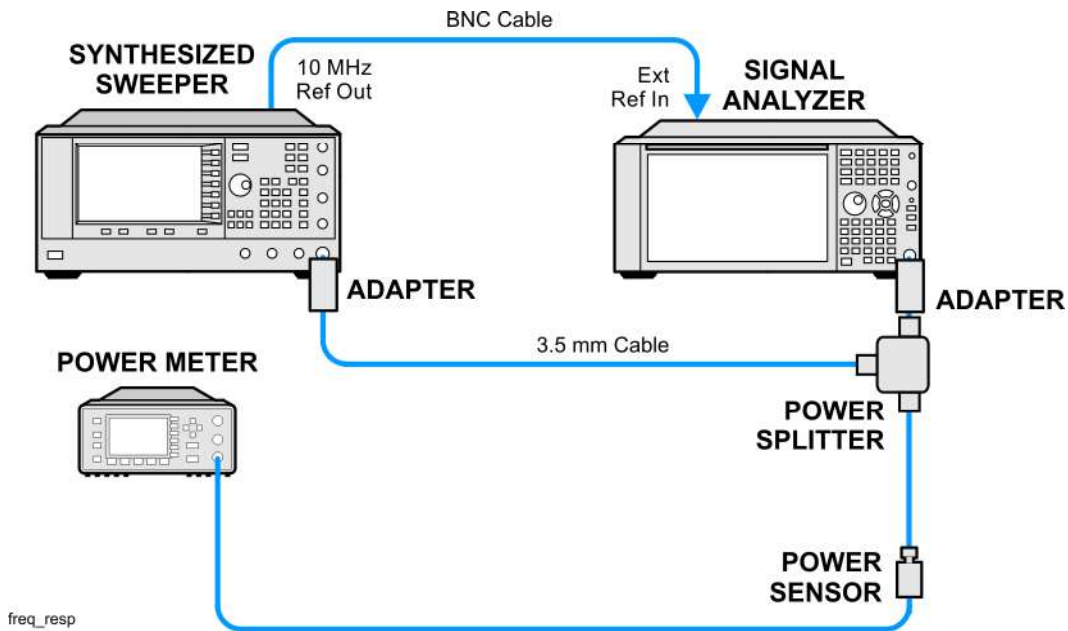

Procedure

1. Zero and calibrate the power meter and power sensor as described in the power meter operation manual.
2. Configure the equipment as shown in [Figure 17-5](#).

**NOTE**

Connect the power splitter to the signal analyzer input using the appropriate adapter. Do not use a cable.

3. Assure the signal analyzer's built-in auto alignment has been performed within the last 24 hours.
4. Press **MODE/MEAS** on the analyzer. Select the **Spectrum Analyzer** mode, **Swept SA** measurement, and **Normal** view. Press **OK**. Press **Mode Preset**. Press **Preset** on the synthesized sweeper.
5. Set up the synthesized sweeper by pressing:

**CW, 50, MHz**  
**Power level, -4, dBm**

6. Set up the signal analyzer by pressing:  
**Input/Output, Freq Ref Input, Freq Ref Input External**  
**FREQ, Center Frequency, 50, MHz**  
**Span, 50, kHz**  
**AMPTD, Ref Level, 0, dBm**
7. Adjust the synthesized sweeper output power for a power meter reading of  $-10 \text{ dBm} \pm 0.1 \text{ dB}$ .
8. On the signal analyzer, press **Single**.
9. Press the **Peak Search** key on the signal analyzer to position the marker on the peak of the signal.
10. Refer to **Table 17-7, "Frequency Response (Flatness) Results."** Enter the amplitude of the signal displayed on the signal analyzer into the  $\text{Meas}_{\text{Amp}}$  column of **Table 17-7**.
11. Enter the power meter reading into the  $\text{Power}_{\text{Meter}}$  column of **Table 17-7**.
12. Tune the synthesized sweeper and signal analyzer to the next frequency listed in **Table 17-7**.
13. Enter the power sensor calibration factor into the power meter.
14. For frequencies 3.6 GHz and above, press **AMPTD Signal Path**, then **Presel Center** to center the preselector filter for an optimum amplitude measurement.
15. Repeat **step 7** through **step 14** and complete the remainder of **Table 17-7** for the frequency range of your analyzer.
16. Compute the measurement error ( $\text{Meas}_{\text{Error}} = \text{Meas}_{\text{Amp}} - \text{Power}_{\text{Meter}}$ ).
17. Compute the flatness error normalized to 50 MHz:  
( $\text{Meas}_{\text{Error}} - \text{Meas}_{\text{Error}} @ 50 \text{ MHz}$ )
18. Enter the computed flatness error value into the  $\text{Flat}_{\text{Norm}}$  column of **Table 17-7**.
19. Compare the value of  $\text{Flat}_{\text{Norm}}$  to the test limit.

Functional Tests  
 Frequency Response (Flatness)

Table 17-7 Frequency Response (Flatness) Results

Center Frequency	Analyzer Amplitude $Meas_{amp}$	Power Meter Measurement $Power_{meter}$	Meas Error $Meas_{error}$	Flatness Normalized to 50 MHz $Flat_{Norm}$	Flatness Error Test Limits (dB)
50 MHz				0	Ref
1 GHz					±1.5 dB
2 GHz					1.5 dB
3 GHz					±1.5 dB
3.5 GHz					±1.5 dB
4 GHz					±2.5 dB
6 GHz					±2.5 dB
8 GHz					±2.5 dB
9 GHz					±3.0 dB
11 GHz					±3.0 dB
13 GHz					±3.0 dB
14 GHz					±3.5 dB
17 GHz					±3.5 dB
20 GHz					±3.5 dB
23 GHz					±3.5 dB
26 GHz					±3.5 dB
29 GHz					±3.5 dB
32 GHz					±3.5 dB
35 GHz					±4.2 dB
38 GHz					±4.2 dB
41 GHz					±4.2 dB
43.5 GHz					±4.2 dB
46 GHz					±4.2 dB
49 GHz					±4.2 dB

## Frequency Response (Flatness), Preamp On

### Test Limits

Frequency Range	Limit Relative to 50 MHz
100 kHz to 3.6 GHz	±2.0 dB
> 3.6 GHz to 8.4 GHz	±3.0 dB
> 8.4 GHz to 13.6 GHz	±3.5 dB
> 13.6 GHz to 26.5 GHz	±4.0 dB
> 26.5 GHz to 34.5 GHz	±4.0 dB
> 34.5 GHz to 50 GHz	±5.1 dB

The frequency response test, with preamplifier on, measures the signal analyzer's amplitude error as a function of the tuned frequency. Measurements are made ranging from 50 MHz to the maximum frequency range of the preamp. The signal source amplitude is measured with a power meter to eliminate error due to source flatness. The measured value is normalized to 50 MHz.

Item	Critical Specifications (for this test)	Recommended Keysight Model
Adapter, Type N(m) to 3.5 mm(m)	Frequency: 10 MHz to 18 GHz VSWR: < 1.1:1	1250-1743
Adapter, 3.5 mm(f) to 3.5 mm(f)	Frequency: 10 MHz to 26.5 GHz VSWR: < 1.1:1	83059B
Cable, 3.5 mm, 1 meter	Frequency: 10 MHz to 26.5 GHz VSWR: < 1.4:1	11500E
Cable, 2.4 mm, 1 meter	Frequency: 10 MHz to 50 GHz VSWR: < 1.55:1	8120-6164
Cables, BNC 120 cm	Frequency: 10 MHz	10503A
Power Meter	Compatible with power sensor	E4418B
Attenuator, 30 dB Fixed	Frequency: 50 MHz Accuracy: ±0.05 dB	11708A

Functional Tests  
 Frequency Response (Flatness), Preamp On

Item	Critical Specifications (for this test)	Recommended Keysight Model
Power Sensor <sup>a</sup>	Frequency: 50 MHz to 26.5 GHz Amplitude: -65 dBm to -55 dBm	8485D
Power Sensor <sup>b</sup>	Frequency: 50 MHz to 50 GHz Amplitude: -65 dBm to -55 dBm	8487D
Power Splitter <sup>a</sup>	Frequency: 50 MHz to 26.5 GHz Tracking between ports: < 0.25 dB	11667B
Power Splitter <sup>b</sup>	Frequency: 50 MHz to 50 GHz Tracking between ports: < 0.4 dB	11667C
Synthesized Sweeper	Frequency: 50 MHz to 50 GHz	PSG

a. For Options 503, 508, 513, and 526  
 b. For Options 532, 544, and 550

Figure 17-6 Frequency Response Test Setup

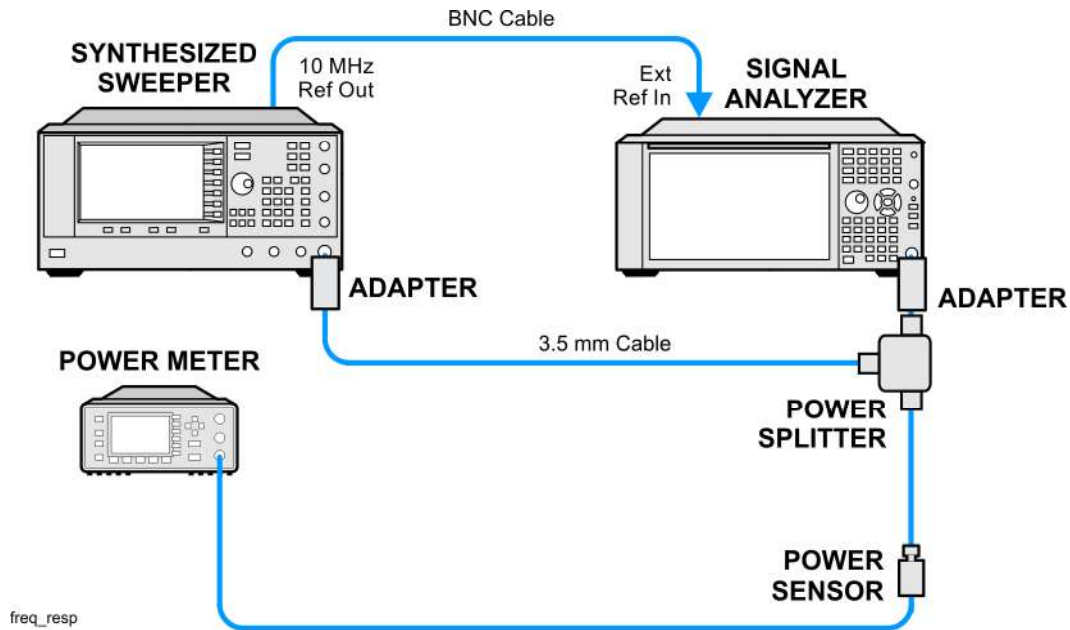

Procedure

1. Zero and calibrate the power meter and power sensor as described in the power meter operation manual.
2. Configure the equipment as shown in [Figure 17-6](#).

**NOTE**

Connect the power splitter to the signal analyzer input using the appropriate adapter. Do not use a cable.

3. Assure the signal analyzer's built-in auto alignment has been performed within the last 24 hours.
4. Press **MODE/MEAS** on the analyzer. Select the **Spectrum Analyzer** mode, **Swept SA** measurement, and **Normal** view. Press **OK**. Press **Mode Preset**. Press **Preset** on the synthesized sweeper.
5. Set up the synthesized sweeper by pressing:
  - CW, 50, MHz**
  - Power level, -54, dBm**
6. Set up the signal analyzer by pressing:
  - Input/Output, Freq Ref Input, Freq Ref Input External**
  - FREQ, Center Frequency, 50, MHz**
  - Span, 50, kHz**
  - AMPTD, Signal Path, Internal Preamp, Full Range**
  - AMPTD, Attenuation, Mech Atten, 0, dB**
  - AMPTD, Y Scale, Ref Level, -55, dBm**
7. Adjust the synthesized sweeper output power for a power meter reading of  $-60 \text{ dBm} \pm 0.1 \text{ dB}$ .
8. On the signal analyzer, press **Single**.
9. Press the **Peak Search** key on the signal analyzer to position the marker on the peak of the signal.
10. Refer to **Table 17-7, "Frequency Response (Flatness) Results."** Enter the amplitude of the signal displayed on the signal analyzer into the  $\text{Meas}_{\text{Amp}}$  column of **Table 17-7**.
11. Enter the power meter reading into the  $\text{Power}_{\text{Meter}}$  column of **Table 17-7**.
12. Tune the synthesized sweeper and signal analyzer to the next frequency listed in **Table 17-7**.
13. Enter the power sensor calibration factor into the power meter.
14. For frequencies 3.6 GHz and above, press **AMPTD, Signal Path**, then **Presel Center** to center the preselector filter for an optimum amplitude measurement.
15. Repeat **step 7** through **step 14** and complete the remainder of **Table 17-7** for the frequency range of your preamp.
16. Compute the measurement error ( $\text{Meas}_{\text{Error}} = \text{Meas}_{\text{Amp}} - \text{Power}_{\text{Meter}}$ ).
17. Compute the flatness error normalized to 50 MHz:  
( $\text{Meas}_{\text{Error}} - \text{Meas}_{\text{Error}} @ 50 \text{ MHz}$ )
18. Enter the computed flatness error value into the  $\text{Flat}_{\text{Norm}}$  column of **Table 17-7**.
19. Compare the value of  $\text{Flat}_{\text{Norm}}$  to the test limit.

Functional Tests  
 Frequency Response (Flatness), Preamp On

Table 17-8 Frequency Response (Flatness) Results

Center Frequency	Analyzer Amplitude $Meas_{amp}$	Power Meter Measurement $Power_{meter}$	Meas Error $Meas_{error}$	Flatness Normalized to 50 MHz $Flat_{Norm}$	Flatness Error Test Limits (dB)
50 MHz				0	Ref
1 GHz					±2.0 dB
2 GHz					±2.0 dB
3 GHz					±2.0 dB
3.5 GHz					±2.0 dB
4 GHz					±3.0 dB
6 GHz					±3.0 dB
8 GHz					±3.0 dB
9 GHz					±3.5 dB
11 GHz					±3.5 dB
13 GHz					±3.5 dB
14 GHz					±4.0 dB
17 GHz					±4.0 dB
20 GHz					±4.0 dB
23 GHz					±4.0 dB
26 GHz					±4.0 dB
29 GHz					±4.0 dB
31 GHz					±4.0 dB
34 GHz					±4.5 dB
37 GHz					±5.1 dB
40 GHz					±5.1 dB
43 GHz					±5.1 dB
47 GHz					±5.1 dB
49.5 GHz					±5.1 dB

## Scale Fidelity

### Test Limits

The scale fidelity error will be  $\leq \pm 1.0$  dB with  $\leq -10$  dBm at the mixer.

This test checks the scale fidelity of the instrument by maintaining a constant reference level and measuring signals of different amplitudes over most of the display range. This test sets the input attenuator to 10 dB and the Reference Level to 0 dBm. The external attenuator is set to 0 dB, and the amplitude of the source is adjusted to set the displayed signal at the reference level.

The instrument's internal marker is used to measure the reference amplitude. The Marker Delta function is activated and the RF input is reduced using the external precision step attenuator. Signal input levels from 0 dBm to -50 dBm are measured.

Item	Critical Specifications (for this test)	Recommended Keysight Model
Adapter, Type-N (m), to 3.5 mm (f) <sup>a</sup>	Frequency: 10 MHz to 18 GHz VSWR: < 1.1:1	1250-1745
Adapter, 3.5 mm (f) to 3.5 mm (f) <sup>a</sup>	Frequency: 10 MHz to 26.5 GHz VSWR: < 1.1:1	83059B
Adapter, 2.4 mm (f) to 3.5 mm (f) (2 required) <sup>b</sup>	Frequency: 50 MHz VSWR: < 1.1:1	11901B
Attenuator, 10 dB Step	Range: 0-50 dB Frequency: 50 MHz Accuracy: $\pm 0.25$ dB	8495A
Attenuator, 10 dB fixed (2 required)	Frequency: 50 MHz VSWR: < 1.2:1	8493C, option 010
Cable, 3.5 mm, 1 meter (2 required)	Frequency: 10 MHz to 26.5 GHz VSWR: < 1.4:1	11500E
Cable, BNC 120 cm	Frequency: 10 MHz	10503A
Synthesized Sweeper	Output Level Accuracy: 0 to -15 dBm: $\pm 1.0$ dB	PSG

a. For Options 503, 508, 513, and 526

b. For Options 532, 544, and 550

Figure 17-7 Scale Fidelity Setup

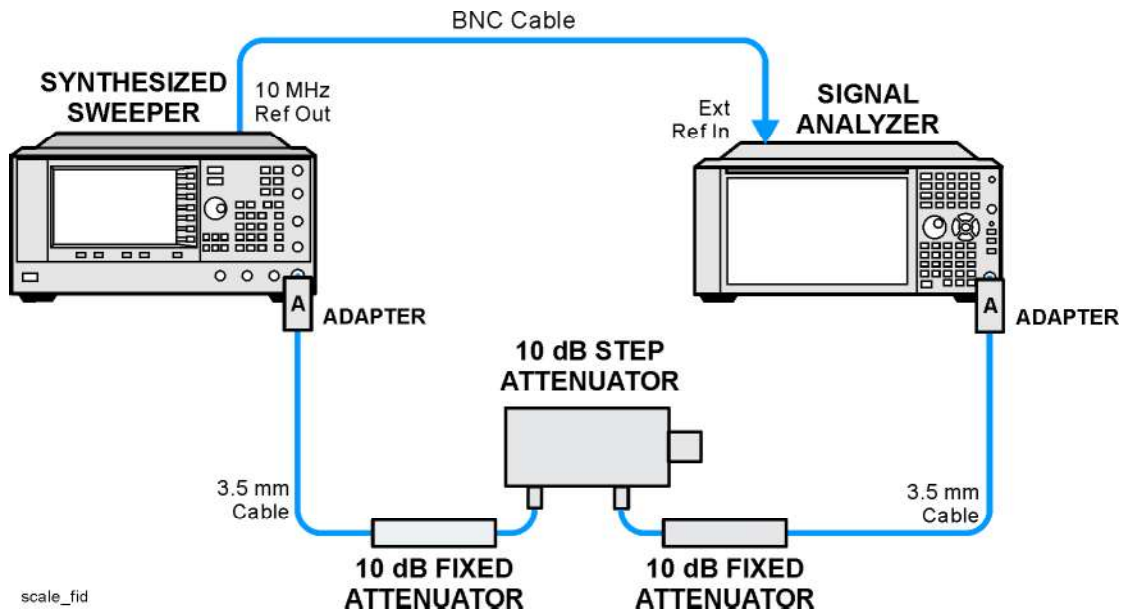

**NOTE**

Averaging is used for all measurements to improve repeatability and reduce measurement uncertainty.

Procedure

1. Configure the equipment as shown in [Figure 17-7](#).
2. Preset the Source and press **MODE/MEAS** on the analyzer. Select the **Spectrum Analyzer** mode, **Swept SA** measurement, and **Normal** view. Press **OK**. Press **Mode Preset**.
3. Set up the synthesized sweeper by pressing:
  - Frequency, 50, MHz**
  - Amplitude, +5, dBm**
  - RF On/Off, On**
4. Set up the signal analyzer by pressing:
  - Input/Output, Freq Ref Input, Freq Ref Input External**
  - FREQ, Center Frequency, 50, MHz**
  - Span, 1, MHz**
  - AMPTD, Y Scale, Ref Level, 0, dBm**
  - Meas Setup, Avg/Hold Number, 10, Enter**
  - Trace, Trace Average**
  - Peak Search**
5. Set the external 10 dB step attenuator to 0 dB.
6. Adjust the amplitude on the signal source until the marker amplitude on the analyzer reads  $-15 \text{ dBm} \pm 0.2 \text{ dB}$ .

7. On the analyzer, press the **Single** key to trigger a 10 sweep average.
8. On the analyzer, activate the Marker Delta function by pressing **Peak Search, Marker Delta**.
9. Perform the following steps for each attenuator setting listed in the table below:
  - a. Select the next External attenuator setting.
  - b. Press the **Restart** key to trigger a 10 sweep average.
  - c. Enter the delta marker value into **Table 17-9**.
  - d. Check delta marker reading against the test limits.

Table 17-9          Scale Fidelity Results

External Attenuator Setting	Minimum (dB)	Marker Delta Value (dB)	Maximum (dB)
0	N/A	Reference	N/A
10	-11.0		-9.0
20	-21.0		-19.0
30	-31.0		-29.0
40	-41.0		-39.0
50	-51.0		-49.0

## BBIQ Input Frequency Response (Option BBA only)

### Test Limits

Frequency Range	Limit Relative to 250 kHz
Frequency Range	Limit Relative to 250 kHz
250 kHz to 10 MHz (Standard)	$\pm 1.75$ dB
250 kHz to 25 MHz (Option B25)	$\pm 1.75$ dB
250 kHz to 40 MHz (Option B40)	$\pm 1.75$ dB

This procedure tests the amplitude response of each of the BBIQ inputs versus frequency. For each input, a reference measurement is made at 250 kHz and then subsequent measurements are made at several frequencies up to the maximum IQ bandwidth. The amplitude difference between the measurement at 250 kHz and subsequent frequencies is calculated and compared to the test limit.

Item	Critical Specifications	Recommended Keysight Model
RF Signal Generator	Frequency: 250 kHz to 40 MHz Amplitude: $\sim -10$ dBm Flatness: $< \pm 0.75$ dB	E4438C
Cable, BNC	Connectors: BNC male Length: 23 cm (9 in) max	10502A
Cable, BNC, 120 cm	Connectors: BNC male Frequency: 250 kHz to 40 MHz	10503A
50 Ohm Termination	Connector: BNC male Frequency: 250 kHz to 40 MHz	11593A

Figure 17-8 BBIQ Input Frequency Response Setup (I Input)

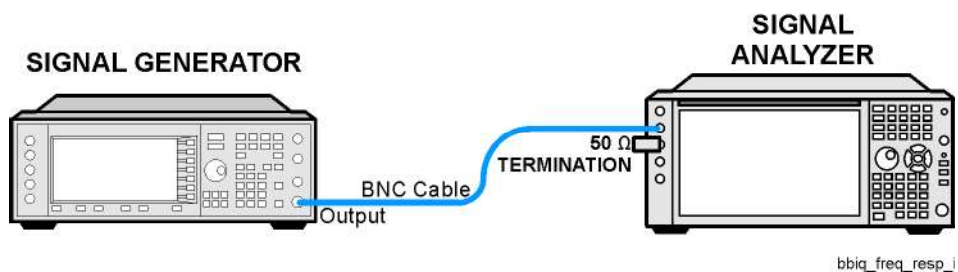

Figure 17-9 BBIQ Input Frequency Response Setup (I Input)

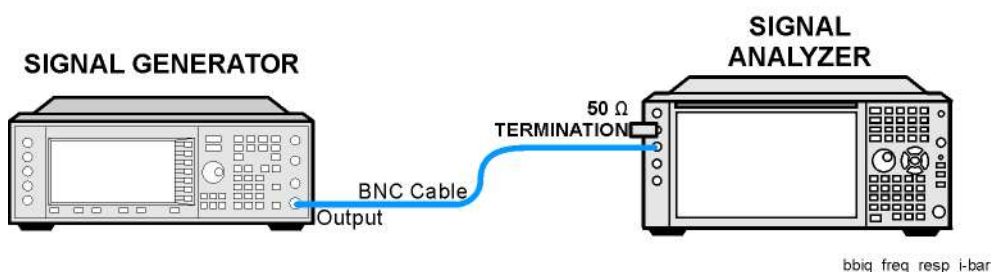

Figure 17-10 BBIQ Input Frequency Response Setup (Q Input)

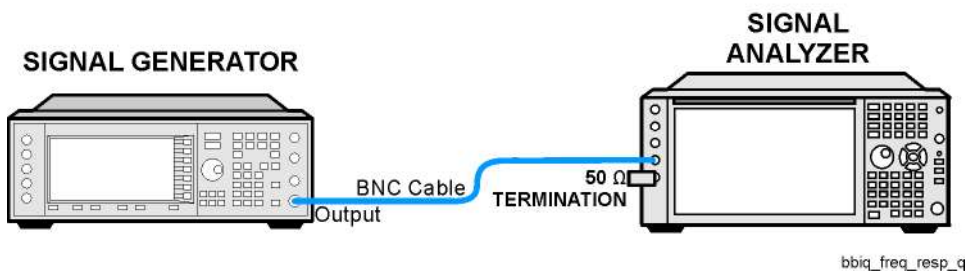
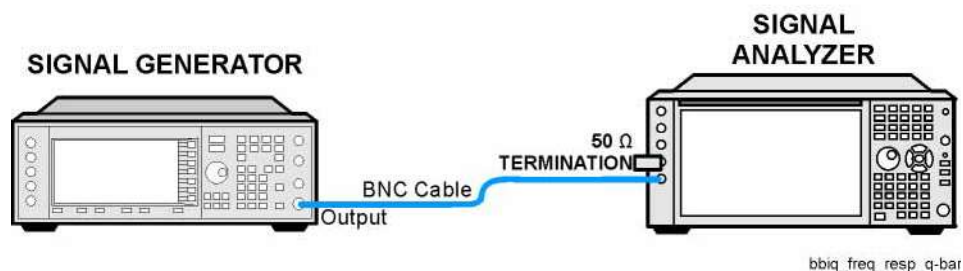

Figure 17-11 BBIQ Input Frequency Response Setup (Q Input)



## Procedure

1. Press **MODE/MEAS** on the analyzer. Select the **I/Q Analyzer (Basic)** mode, **Complex Spectrum** measurement, and **Normal** view. Press **OK**. Press **Mode Preset**.
2. Press **Input/Output Input, Select Input, I/Q**, (to change to I/Q inputs), **I/Q** (to bring up the I/Q input menu), **I/Q Cable Calibrate**. Follow the instructions on screen. Use the short BNC cable listed above to perform the calibration. This process has several steps and will take about 3 minutes to perform.
3. Press **I/Q Path, I+jQ, I/Q Setup, I Setup, Differential (On)**. Press **Return, Q Setup, Q Same as I (On)**.
4. Preset the RF Signal Generator and set the controls as follows:

Frequency	250 kHz
Amplitude	-10 dBm
RF	On

### NOTE

Once the RF Signal Generator's Amplitude is set, do not change the RF Signal Generator's Amplitude setting during the rest of this procedure.

5. Connect the longer BNC cable between the RF Signal Generator's RF OUTPUT and the I input of the X-Series analyzer, see [Figure 17-7](#).
6. Connect the 50 Ohm termination to the I input of the X-Series analyzer, see [Figure 17-7](#).
7. Press **Mode Preset** on the X-Series analyzer. Press **System, Show System**. Note if either of the options listed below are present:  
N9020B-B25  
N9020B-B40
8. If none of the options listed in [step 7](#) are present, the maximum IQ bandwidth is 10 MHz.
9. If N9020B-B25 is present, but N9020B-B40 is not present, the maximum IQ bandwidth is 25 MHz.
10. If N9020B-B40 is present, the maximum IQ bandwidth is 40 MHz.
11. Press **FREQ** on the X-Series analyzer and set the Center Freq equal to one half the maximum IQ bandwidth determined above. For example, if the maximum IQ bandwidth is 40 MHz, set the Center Freq to 20 MHz.
12. Press **FREQ, Span** on the X-Series analyzer and set the Span equal to the maximum IQ bandwidth determined above.
13. Press **BW** on the X-Series analyzer and set the Res BW to 100 kHz.
14. Press **Peak Search** on the X-Series analyzer. Record the marker amplitude reading in [Table 17-10](#) for the I Input at 250 kHz.

**15.** Set the RF Signal Generator to each of the remaining frequencies listed in Table 1, up to the maximum IQ bandwidth of the X-Series analyzer. At each frequency, do the following:

- a. Press **Peak Search**
- b. Record the marker amplitude reading in **Table 17-10** for the I Input at the current RF Signal Generator frequency

Table 17-10 BBIQ Input Frequency Response, I and I Inputs

RF Signal Generator Frequency	I Input		I Input		Test Limits
	Marker Amplitude	Frequency Response	Marker Amplitude	Frequency Response	
250 kHz		0.0 dB		0.0 dB	±1.75 dB
2 MHz					±1.75 dB
5 MHz					±1.75 dB
7.5 MHz					±1.75 dB
9.9 MHz					±1.75 dB
Stop here if Maximum IQ Bandwidth is 10 MHz					
12.5 MHz					±1.75 dB
15 MHz					±1.75 dB
17.5 MHz					±1.75 dB
20 MHz					±1.75 dB
22.5 MHz					±1.75 dB
24.9 MHz					±1.75 dB
Stop here if Maximum IQ Bandwidth is 25 MHz					
30 MHz					±1.75 dB
35 MHz					±1.75 dB
39.9 MHz					±1.75 dB

- 16.** Set the RF Signal Generator frequency to 250 kHz
- 17.** Connect the BNC Cable between the RF Signal Generator RF Output and the I input on the X-Series analyzer, see **Figure 17-9**
- 18.** Connect the 50 Ohm termination to the I input on the X-Series analyzer, see **Figure 17-9**
- 19.** Press **Peak Search** on the X-Series analyzer. Record the marker amplitude reading in **Table 17-10** for the I Input at 250 kHz.

20. Set the RF Signal Generator to each of the remaining frequencies listed in [Table 17-10](#), up to the maximum IQ bandwidth of the X-Series analyzer. At each frequency, do the following:

- a. Press **Peak Search**
- b. Record the marker amplitude reading in [Table 17-10](#) for the I Input at the current RF Signal Generator frequency

**NOTE**

Since the input is set for I + Q and the input signal is being applied to I only, the analyzer will measure 6 dB lower than the signal generator output; in this case

$$-10 \text{ dB} - +6 \text{ dB} = -16 \text{ dB}$$

This will be the case for I, I, Q, and Q inputs.  
This is because the Fourier transform of

$$A \sin(\omega t) = \frac{1}{2} A e^{j\omega t} + \frac{1}{2} A e^{-j\omega t}$$

Since a signal is placed at  $\omega$  or  $-\omega$ , the result will be  $20 \log(1/2)$  lower.  
The transform is in voltage and not power.

---

21. Connect the BNC Cable between the RF Signal Generator RF Output and the Q input on the X-Series analyzer, see [Figure 17-10](#)

22. Connect the 50 Ohm termination to the Q input on the X-Series analyzer, see [Figure 17-10](#)

23. Set the RF Signal Generator frequency to 250 kHz.

24. Press **Peak Search** on the X-Series analyzer. Record the marker amplitude reading in [Table 17-11](#) for the Q Input at 250 kHz.

25. Set the RF Signal Generator to each of the remaining frequencies listed in [Table 17-11](#), up to the maximum IQ bandwidth of the X-Series analyzer. At each frequency, do the following:

Press **Peak Search**

Record the marker amplitude reading in [Table 17-11](#) for the Q Input at the current RF Signal Generator frequency

Table 17-11 BBIQ Input Frequency Response, Q and Q Inputs

RF Signal Generator Frequency	I Input		I Input		Test Limits
	Marker Amplitude	Frequency Response	Marker Amplitude	Frequency Response	
250 kHz		0.0 dB		0.0 dB	±1.75 dB
2 MHz					±1.75 dB
5 MHz					±1.75 dB
7.5 MHz					±1.75 dB
9.9 MHz					±1.75 dB
<b>Stop here if Maximum IQ Bandwidth is 10 MHz</b>					
12.5 MHz					±1.75 dB
15 MHz					±1.75 dB
17.5 MHz					±1.75 dB
20 MHz					±1.75 dB
22.5 MHz					±1.75 dB
24.9 MHz					±1.75 dB
<b>Stop here if Maximum IQ Bandwidth is 25 MHz</b>					
30 MHz					±1.75 dB
35 MHz					±1.75 dB
39.9 MHz					±1.75 dB

26. Set the RF Signal Generator frequency to 250 kHz
27. Connect the BNC Cable between the RF Signal Generator RF Output and the Q input on the X-Series analyzer, see [Figure 17-11](#)
28. Connect the 50 Ohm termination to the Q input on the X-Series analyzer, see [Figure 17-11](#)
29. Press **Peak Search** on the X-Series analyzer. Record the marker amplitude reading in [Table 17-11](#) for the Q Input at 250 kHz.
30. Set the RF Signal Generator to each of the remaining frequencies listed in [Table 17-11](#), up to the maximum IQ bandwidth of the X-Series analyzer. At each frequency, do the following:
  - a. Press **Peak Search**
  - b. Record the marker amplitude reading in [Table 17-11](#) for the Q Input at the current RF Signal Generator frequency

Functional Tests

BBIQ Input Frequency Response (Option BBA only)

**31.**In **Table 17-10** and **Table 17-11**, calculate the Frequency Response for each input by subtracting the Marker Amplitude at 250 kHz for that input from the Marker Amplitude for each frequency greater than 250 kHz.

$$\text{Frequency Response} = \text{Marker Amplitude (Freq > 250 kHz)} - \text{Marker Amplitude (250 kHz)}$$

**32.**Compare the Frequency Response values to the Test Limits.