



Agilent 34931A-34933A Matrix Modules

User's Guide

Agilent Technologies, Inc.
Printed in Malaysia
Edition 1
June 2008 E0608

* 34980-90031 *
34980-90031

Notices

© Agilent Technologies, Inc. 2008

No part of this manual may be reproduced in any form or by any means (including electronic storage and retrieval or translation into a foreign language) without prior agreement and written consent from Agilent Technologies, Inc. as governed by United States and international copyright laws.

Manual Part Number

34980-90031

Edition

First Edition, June 2008

Printed in Malaysia

Agilent Technologies, Inc.
3501 Stevens Creek Blvd
Santa Clara, CA 95052 USA

Microsoft® and Windows® are U.S. registered trademarks of Microsoft Corporation.

Software Revision

This guide is valid for the firmware that was installed in the instrument at the time of manufacture. However, upgrading the firmware may add or change product features. For the latest firmware and documentation, go to the product page at:

www.agilent.com/find/34980A

Warranty

The material contained in this document is provided “as is,” and is subject to being changed, without notice, in future editions. Further, to the maximum extent permitted by applicable law, Agilent disclaims all warranties, either express or implied, with regard to this manual and any information contained herein, including but not limited to the implied warranties of merchantability and fitness for a particular purpose. Agilent shall not be liable for errors or for incidental or consequential damages in connection with the furnishing, use, or performance of this document or of any information contained herein. Should Agilent and the user have a separate written agreement with warranty terms covering the material in this document that conflict with these terms, the warranty terms in the separate agreement shall control.

Technology Licenses

The hardware and/or software described in this document are furnished under a license and may be used or copied only in accordance with the terms of such license.

Restricted Rights Legend

U.S. Government Restricted Rights. Software and technical data rights granted to the federal government include only those rights customarily provided to end user customers. Agilent provides this customary commercial license in Software and technical data pursuant to FAR 12.211 (Technical Data) and 12.212 (Computer Software) and, for the Department of Defense, DFARS 252.227-7015 (Technical Data - Commercial Items) and DFARS 227.7202-3 (Rights in Commercial Computer Software or Computer Software Documentation).

Safety Notices

CAUTION

A **CAUTION** notice denotes a hazard. It calls attention to an operating procedure, practice, or the like that, if not correctly performed or adhered to, could result in damage to the product or loss of important data. Do not proceed beyond a **CAUTION** notice until the indicated conditions are fully understood and met.

WARNING

A **WARNING** notice denotes a hazard. It calls attention to an operating procedure, practice, or the like that, if not correctly performed or adhered to, could result in personal injury or death. Do not proceed beyond a **WARNING** notice until the indicated conditions are fully understood and met.

Additional Safety Notices

The following general safety precautions must be observed during all phases of operation of this instrument. Failure to comply with these precautions or with specific warnings or instructions elsewhere in this manual violates safety standards of design, manufacture, and intended use of the instrument. Agilent Technologies assumes no liability of the customer's failure to comply with the requirements.

General

Do not use this products in any manner not specified by the manufacturer. The protective features of this product may be impaired if it is used in a manner not specified in the operation instructions.

Before Applying Power

Verify that all safety precautions are taken. Make all connections to the unit before applying power.

Ground the Instrument

This product is provided with protective earth terminals. To minimize shock hazard, the instrument must be connected to the ac power mains through a grounded power cable, with the ground wire firmly connected to an electrical ground (safety ground) at the power outlet. Any interruption of the protective (grounding) conductor or disconnection of the protective earth terminal will cause a potential shock hazard that could result in personal injury.

Do Not Operate in an Explosive Atmosphere

Do not operate the instrument in the presence of flammable gases or fumes.

Do Not Remove the Instrument Cover

Only qualified, service-trained personal who are aware of the hazards involved should remove instrument covers. Always disconnect the power cable and any external circuits before removing the instrument cover.

Do Not Modify the Instrument

Do not install substitute parts or perform any unauthorized modification to the product. Return the product to an Agilent Sales and Service Office for service and repair to ensure that safety features are maintained.

In Case of Damage

Instruments that appear damaged or defective should be made inoperative and secured against unintended operation until they can be repaired by qualified service personnel.

Safety Symbols

 Alternating current

 Frame or chassis terminal

 Standby supply. Unit is not completely disconnected from ac mains when switch is off

 Caution, risk of electric shock

 Caution, refer to accompanying description

Waste Electrical and Electronic Equipment (WEEE) Directive 2002/96/EC



This product complies with the WEEE Directive (2002/96/EC) marking requirement. The affixed product label (see above) indicates that you **must not discard this electrical/electronic product in domestic household waste.**

Product Category: With reference to the equipment types in the WEEE directive Annex 1, this product is classified as a "Monitoring and Control instrumentation" product.

To return unwanted products, contact your local Agilent office, or go to www.agilent.com/environment/product for more information.

Technical Support

If you have questions about your shipment, or if you need information about warranty, service, or technical support, contact Agilent Technologies:

In the United States: (800) 829-4444
In Europe: 31 20 547 2111
In Japan: 0120-421-345

Or go to www.agilent.com/find/assist for information on contacting Agilent in your country of specific location. You can also contact your Agilent Technologies Representative.

The **Declaration of Conformity (DoC)** for the 34980A mainframe instrument can be found on page iii in the *34980A Mainframe User's Guide*. That DoC applies to the 34980A mainframe and all available plug-in modules.

Contents

Matrix Modules	1
Operating Considerations	2
SCPI Programming Examples for the Matrix Modules	3
Linking Multiple Matrix Modules	6
34931A Dual 4x8 Armature Matrix	8
34931A Simplified Schematic	9
34931A D-Sub Connectors	10
34931T Terminal Block	11
34932A Dual 4x16 Armature Matrix	13
34932A Simplified Schematic	14
34932A D-Sub Connectors	15
34932T Terminal Block	16
34933A Dual/Quad 4x8 Reed Matrix	17
34933A Simplified Schematic for Two-Wire Mode	19
34933A D-Sub Connectors for Two-Wire Mode	20
34933T-001 Terminal Block for Two-Wire Mode	21
34933A Simplified Schematic for One-Wire Mode	23
34933A D-Sub Connectors for One-Wire Mode	24
34933T-002 Terminal Block for One-Wire Mode	25

Matrix Modules

This User's Guide covers the following three plug-in modules for the Agilent 34980A Multifunction Switch/Measure Unit::

34931A	Dual 4x8 armature matrix
34932A	Dual 4x16 armature matrix
34933A	Dual/Quad 4x8 reed matrix

The 34931A has two (dual) matrices of latching armature switches. Each matrix is organized in a 4-row by 8-column configuration.

The 34932A has two (dual) matrices of latching armature switches. Each matrix is organized in a 4-row by 16-column configuration.

The 34933A has non-latching reed switches, which you can configure for:

- differential (2-wire) mode, which has two (dual) matrices. Each matrix is organized in a 4-row by 8-column configuration.
- single-ended (1-wire) mode, which has four (quad) matrices. Each matrix is organized in a 4-row by 8-column configuration.

These matrix switch modules offer a convenient way for you to connect multiple instruments to multiple points on your device under test. For a lower cost and better specification alternative, you can connect both matrix and multiplexer (MUX) modules.

Operating Considerations

Connection to Voltage Sources

Although flexible, it is possible to connect more than one source at the same time with a matrix. Make sure that dangerous or unwanted conditions are not created by these connections.

NOTE

Safety Interlock The Analog Buses of the 34980A are capable of carrying 300V signals. The matrix modules have a hardware *Safety Interlock* feature that automatically opens the Analog Bus relays when the associated interlock pins on the D-sub connectors (faceplate) lose continuity. This prevents signals on the Analog Buses from being present on the D-sub connector pins. Optional terminal blocks available from Agilent automatically provide continuity for these interlock pins. If cables are used, you must provide continuity for the interlock pins in your DUT assembly. See the pinout information later in this manual for the location of interlock pins on each module.

The matrix modules have Analog Bus relays on Bank 2 only. Therefore, the interlock pins are present on only the Bank 2 D-sub connectors.

Normally, if you attempt to connect to the Analog Buses without a terminal block or cable connected, an error is generated. The `SYSTEM:ABUS:INTERlock:SIMulate` command allows you to temporarily disable errors generated by the Safety Interlock feature and enables the simulation mode. Although Safety Interlock errors are suppressed in this mode, the actual Analog Bus relays affected by the Safety Interlock are disabled as long as no terminal block or cable is connected to the module.

Electrical Considerations

See the *Introduction to the Plug In Modules* chapter of the 34980A Mainframe User's Guide for detailed environmental operating conditions for the 34980A mainframe and its installed modules. That guidance sets maximum per channel current and power ratings at rated voltage for pollution degree 1 (dry) and pollution degree 2 (possible condensation) conditions, for each of the matrix modules.

SCPI Programming Examples for the Matrix Modules

The programming examples below provide you with SCPI command examples to use for actions specific to the matrix switch modules.

The slot and channel addressing scheme used in these examples follow the general form **sccc** where **s** is the mainframe slot number (1 through 8) and **ccc** is the three-digit channel number. Channel numbers for the matrix modules are derived as follows:

Two-wire mode: The channel numbers for the 34931A, 34932A, and the 34933A (2-wire mode) are derived from the crosspoint or intersection of rows and columns, columns having two digits. See the example below.

Displayed Channel	Means This...
5304	A 34931A, 34932A, 34933A (2-wire mode) matrix module is in slot 5, crosspoint is row 3, column 4. It might be easy to remember this channel configuration as "srcc" (slot, row, column, column)

One-wire mode: The channel numbers for the 34933A (in 1-wire mode) are derived from a specific matrix number and the crosspoint or intersection of rows and columns on that matrix. See the example below.

Displayed Channel	Means This...
2437	A 34933A matrix module in 1-wire mode is in slot 2, matrix of interest is 4, crosspoint is row 3, column 7. It might be easy to remember this channel configuration as "smrc" (slot, matrix, row, column)

For information on specific configurations, refer to the simplified schematics for the matrix modules on [page 9](#), [page 14](#), [page 19](#) and [page 23](#).

For complete information on the SCPI commands used to program the 34980A, refer to the *Agilent 34980A Programmer's Reference* contained on the *34980A Product Reference* CD. For example programs, also refer to the *34980A Product Reference* CD.

Opening and Closing Channels

Example: Closing and opening matrix channels (34931A, 34932A, and 34933A in two-wire mode) The following commands close and open channels 311 and 312 through 315 of a 34932A matrix module in 2-wire mode. This module is in slot 3. The channel number represents the matrix crosspoint of a row (one digit) and a column (two digits). For example, channel 311 represents crosspoint at row 3 and column 11 on a 34932A module.

```
ROUTE:CLOSE (@3311,3312:3315)
ROUTE:OPEN (@3311,3312:3315)
```

Example: Closing and opening matrix channels (34933A in one-wire mode) The following commands close and open channels 311 and 312 through 315 of the 34933A module in 1-wire mode. The module is in slot 4. The channel number represents the matrix and the matrix crosspoint of a row (one digit) and a column (one digit). For example, channel 311 represents the crosspoint on matrix 3 at row 1, column 1 on a 34933A module in 1-wire mode.

```
ROUTE:CLOSE (@3311,3312:3315)
ROUTE:OPEN (@3311,3312:3315)
```

NOTE

Although the previous two examples show the same channel numbers, the channels are derived differently as determined by a module's configuration mode. See [page 3](#) for channel number derivation.

Example: Closing and opening Analog Bus relays The following command connects the Analog Buses to Matrix 2 for a module (in 2-wire mode) in slot 3.

```
ROUTE:CLOSE (@3921,3922,3923,3924)
ROUTE:OPEN (@3921,3922,3923,3924)
```

NOTE

For matrix modules in 2-wire mode, only Matrix 2 connects to the the Analog Buses. For the 34933A in 1-wire mode, only Matrix 3 and Matrix 4 connect to the Analog Buses.

The Analog Bus relays (numbered s921, s922, s923, etc.) on the matrix modules are ignored if they are included in a range of channels. An error will be generated if an Analog Bus relay is specified as the first or last channel in a range of channels. For example, the following command closes all valid channels between channel 304 and channel 615 (slot 2). In addition, this command closes Analog Bus relay 911 on the module in slot 1 (Bank 1). Note that although the specified range of channels includes the other Analog Bus relays, they are ignored and are not closed by this command.

```
ROUTE:CLOSE (@2304:2615,1911)
```

Example: Querying channels for open or close state The following command returns a 1 (true) or 0 (false) state of channel 204 for a module in slot 3.

```
ROUTe:CLOSE (@3204)
ROUTe:CLOSE? (@3204) !Returns a 1
ROUTe:OPEN? (@3204) !Returns a 0
```

Configuring a Module

Example: Configuring the 34933A module for 2-wire or 1-wire mode The following command configures a matrix module in slot 4 for 1-wire measurements. Because you can configure only the 34933A (and the 34923A and 34925A MUX modules) for either 2-wire or 1-wire mode, an error is generated if you send this command to a slot that does not contain one of those three modules. If you are using terminal blocks with the 34933A module, be sure to use the corresponding 2-wire or 1-wire terminal block.

```
SYSTem:MODUle:WIRE:MODE WIRE1,4
```

NOTE

When using a command to configure the system, the new configuration does not take effect until you cycle power on the 34980A.

Example: Querying the system for module Identify The following command returns the identity of the module installed in slot 7.

```
SYSTem:CTYPe? 7
```

NOTE

For the 34933A matrix module, the query response may include a suffix to indicate a 1-wire configuration. For example, the response for the 34933A will be either "34933A" (differential mode) or "34933A-1W" (single-ended mode).

Reading Cycle Count and Resetting Modules to Power-On State

Example: Reading the cycle count for a relay The following command returns the cycle count on channels 304 and 308 for a matrix module in slot 3.

```
DIAGnostic:RELay:CYCLes? (@3304,3308)
```

Example: Resetting module(s) to power-on state The following command resets a module in slot 4 to its power-on state.

```
SYSTem:CPON 4
```

Linking Multiple Matrix Modules

You can link multiple matrix modules to form a larger matrix. The drawings on [page 7](#) show examples of two-module connections through rows and columns.

Wiring Multiple 34931A or 34932A Modules

With a 34931A you can combine two matrices to form 8x8 (connecting columns) or 4x16 (connecting rows) configurations. Using two 34932A matrices on a 34932A module, you can create 16x8 (connecting columns) or 4x32 (connecting rows) configurations.

You can connect rows in separate modules using external wiring. Or, using Bank 2 matrices, you can connect through the mainframe Analog Buses. For a clear idea of how matrices are arranged and their connections to the Analog Buses, see the simplified schematics on [page 9](#) (34931A) and [page 14](#) (34932A).

You must use external wiring whenever you connect:

- Rows in Matrix 1 of separate modules
- Rows in Matrix 1 to rows in Matrix 2 on the same or separate modules
- Columns of two matrices on the same or separate modules

You can expand upon these two-module configurations and add up to eight modules to design your own large matrices. From a programming standpoint, each matrix module operates as an independent module regardless of the external connections. When linking modules, the channel numbering scheme remains the same as for single modules.

Wiring Multiple 34933A Modules

You can connect matrices on the 34933A module in a similar fashion to the 34931A. However, the presence of in-rush resistors on the Analog Buses and columns require additional consideration, and you must take care when linking multiple 34933A matrix modules. See the simplified schematics on [page 19](#) and [page 23](#).

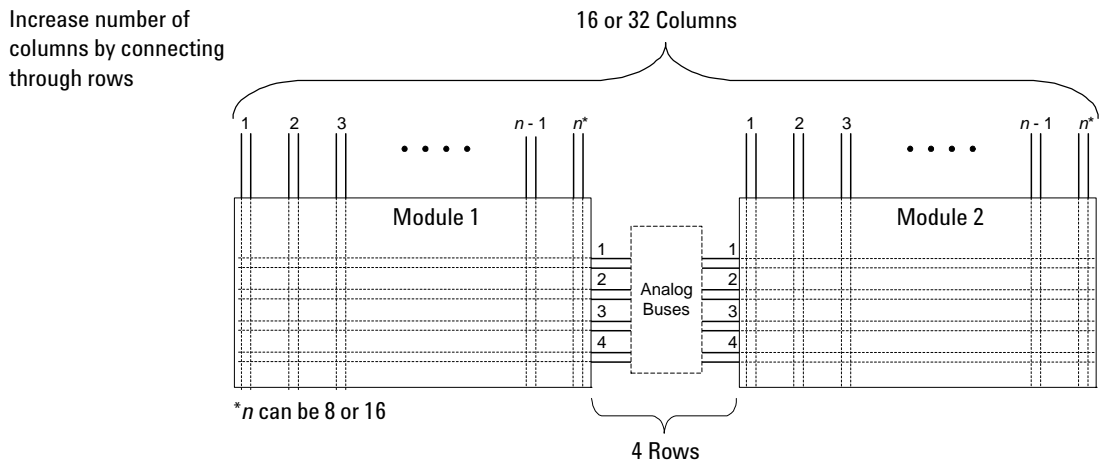
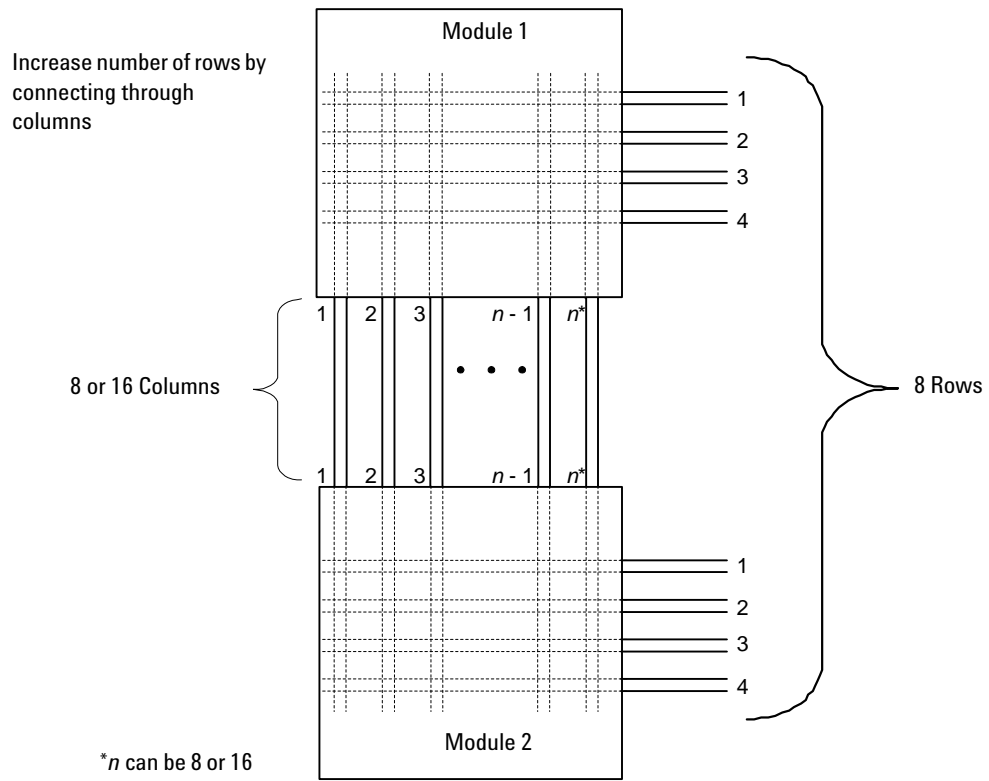

34931A Dual 4x8 Armature Matrix

The 34931A dual 4x8 armature matrix contains two matrices, each with 32 2-wire crosspoint latching armature relays organized in a 4-row by 8-column configuration. Every row and column are made up of two wires each, a high (H) and a low (L). Each crosspoint relay has a unique channel number representing the row and column that intersects to create the crosspoint. For example, channel 304 represent the crosspoint connection between row 3 and column 4 (all columns consisting of two digits; in this case the digits are 04). See the simplified schematic on [page 9](#).

You can connect any combination of inputs and outputs at the same time. However, only Matrix 2 in this module connects to the Analog Buses. By closing channels 921 and 922 you can connect rows 5 and 6 respectively to the internal DMM of the 34980A mainframe for voltage and resistance measurements. You can connect multiple matrix modules externally and/or through the Analog Buses for applications that require large matrices. For information on linking multiple matrices, refer to [page 6](#) of this manual.

NOTE

When the DMM is scanning, it controls ABus1 and ABus2 relays, which are on Matrix 2. Therefore, consider this behavior when you are connecting matrices.

When the power is off, matrix relays maintain state, and Analog Bus relays open.

34931A Simplified Schematic

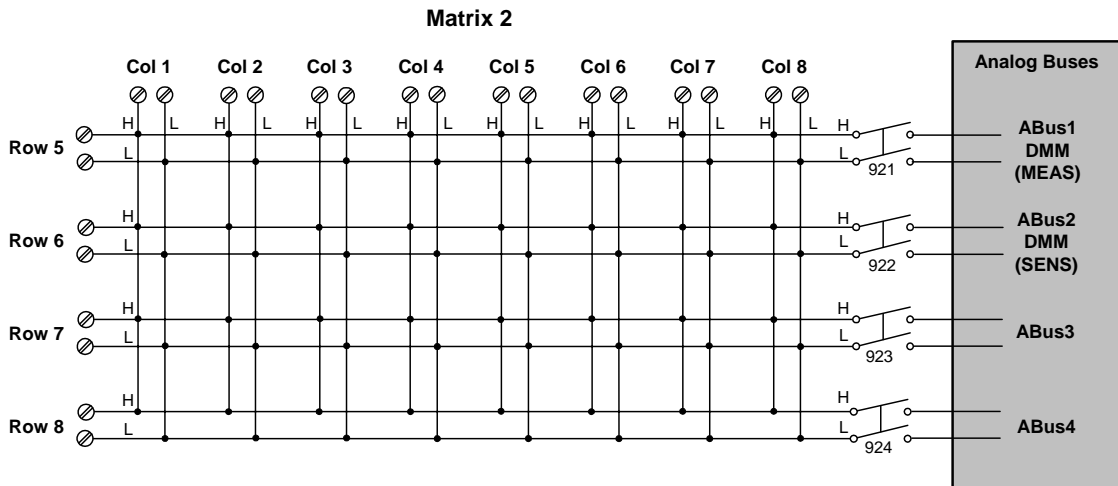
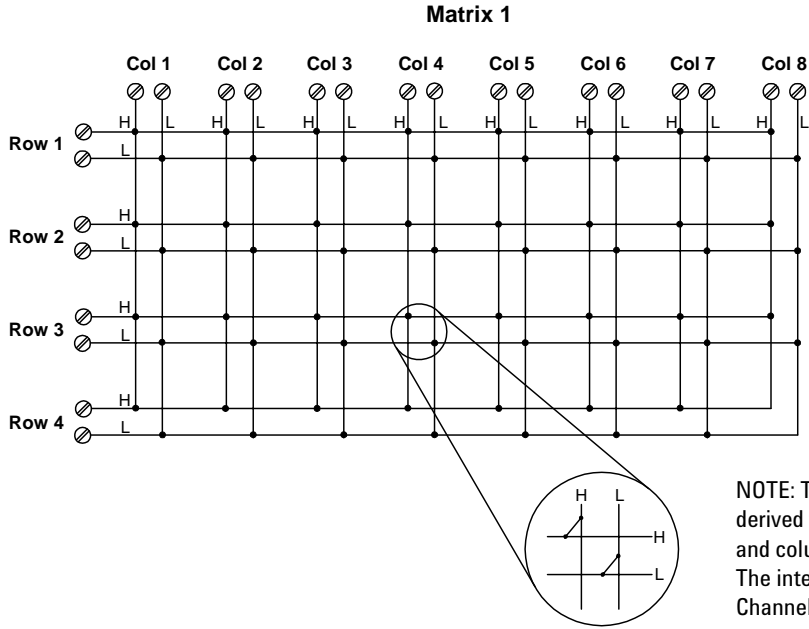

NOTE: Matrix 1 and Matrix 2 are electrically separate from one another.

NOTE:
 Matrix Relays: Armature latching
 Analog Bus Relays: Armature non-latching

34931A D-Sub Connectors

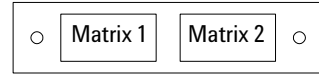

Matrix 1

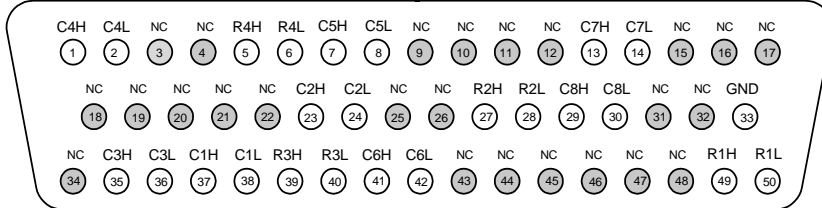

For orientation, the D-sub connector end of the module is facing you.

NOTE: In this diagram and the table below, R represents “row,” and C represents “column.”

50-Pin D-Sub Male Connector

Description	Pin	Description	Pin	Description	Pin
R1H	49	C2H	23	C7H	13
R1L	50	C2L	24	C7L	14
R2H	27	C3H	35	C8H	29
R2L	28	C3L	36	C8L	30
R3H	39	C4H	1	GND	33
R3L	40	C4L	2	No Connect pins: 3-4, 9-12, 15-22, 25-26, 31-32, 34, and 43-48.	
R4H	5	C5H	7		
R4L	6	C5L	8		
C1H	37	C6H	41		
C1L	38	C6L	42		

Matrix 2

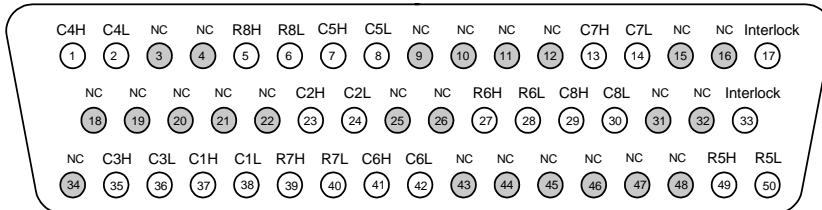

NOTE: In this diagram and the table below, R represents “row,” and C represents “column.”

50-Pin D-Sub Male Connector

WARNING As a safety feature, interlock pins (17 and 33) must be shorted to enable the Analog Bus relays, which are on Matrix 2, to close. The optional 34931T terminal block shorts these pins for you. This feature protects inadvertent routing of high voltages from the Analog Buses to the D-sub connector of the module.

Description	Pin	Description	Pin	Description	Pin
R5H	49	C2H	23	C7H	13
R5L	50	C2L	24	C7L	14
R6H	27	C3H	35	C8H	29
R6L	28	C3L	36	C8L	30
R7H	39	C4H	1	Interlock	17
R7L	40	C4L	2	Interlock	33
R8H	5	C5H	7	No Connect pins: 3-4, 9-12, 15-16, 18-22, 25-26, 31-32, 34, 43-48	
R8L	6	C5L	8		
C1H	37	C6H	41		
C1L	38	C6L	42		

34931T Terminal Block

This terminal block with screw-type connections is labeled with the model number and the abbreviated module name. In addition, space is available on the label for you to write the slot number.

NOTE

All modules that connect to the internal DMM are interlock protected. This means that when an installed module is exposed (no terminal block or cable is connected), the Analog Bus relays, which are on Matrix 2, are open and disconnected from the Analog Buses. See [page 2](#) for further information.

The *34980A Product Reference* CD (shipped with the instrument) contains a 34931T Wiring Log for you to document your wiring configuration for this module. You can open the wiring log file in Microsoft® Excel® or Adobe® Acrobat® format.

NOTE

On the 34931T terminal block, only two sets of screw terminals are for use with the 34931A module. See the following drawing.

When using the 34931T terminal block, be sure to wire your connections to the two sets of screw terminals closest to the 50-pin D-sub connectors.

Wire Size:
20 AWG Typical
18 AWG Max

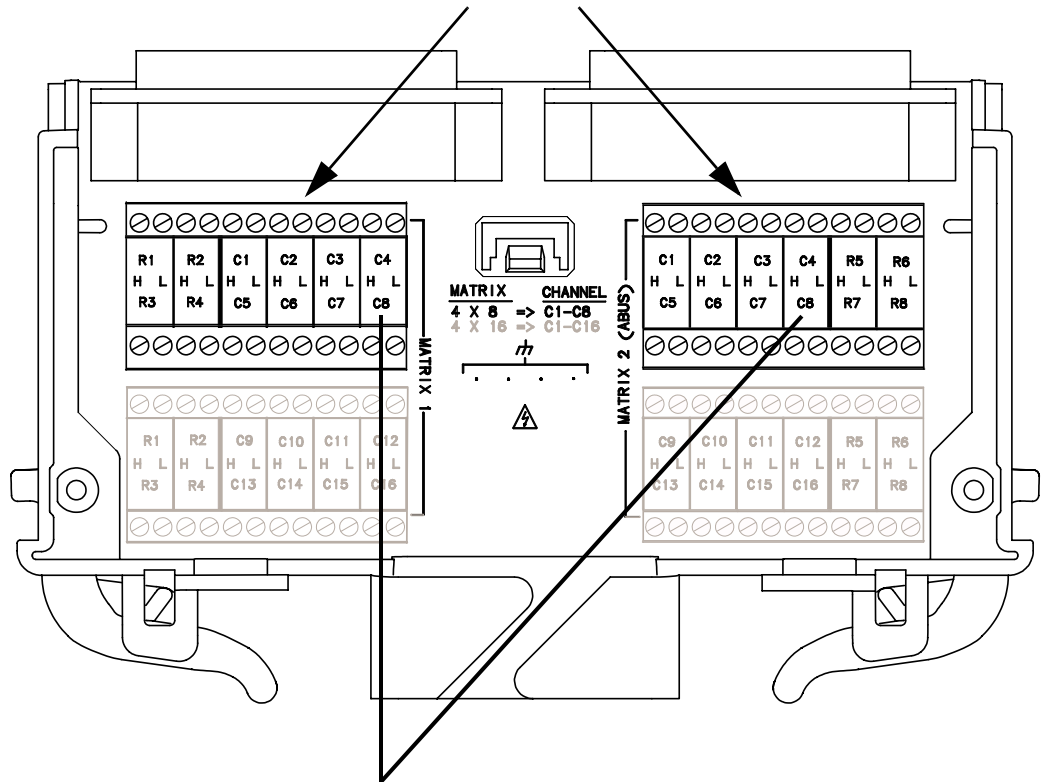

Although columns are numbered the same on Matrix 1 and Matrix 2, they are electrically separate from one another (e.g., Col C8).

34932A Dual 4x16 Armature Matrix

The 34932A dual 4x16 armature matrix contains two matrices, each with 64 2-wire crosspoint latching armature relays organized in a 4-row by 16-column configuration. Every row and column are made up of two wires each, a high (H) and a low (L). Each crosspoint relay has a unique channel number representing the row and column that intersect to create the crosspoint. For example, channel 315 represents the crosspoint connection between row 3 and column 15 (all columns consisting of two digits; in this case the digits are 15). See the simplified schematic on [page 14](#).

You can connect any combination of inputs and outputs at the same time. However, only Matrix 2 in this module connects to the Analog Buses. By closing channels 921 and 922 you can connect rows 5 and 6 respectively to the internal DMM of the 34980A mainframe for voltage and resistance measurements. You can connect multiple matrix modules externally and/or through the Analog Buses for applications that require large matrices. For information on linking multiple matrix modules, refer to [page 6](#) of this manual.

NOTE

When the DMM is scanning, it controls ABus1 and ABus2 relays, which are on Matrix 2. Therefore, consider this behavior when you are connecting matrices.

When the power is off, matrix relays maintain state, and Analog Bus relays open.

34932A Simplified Schematic

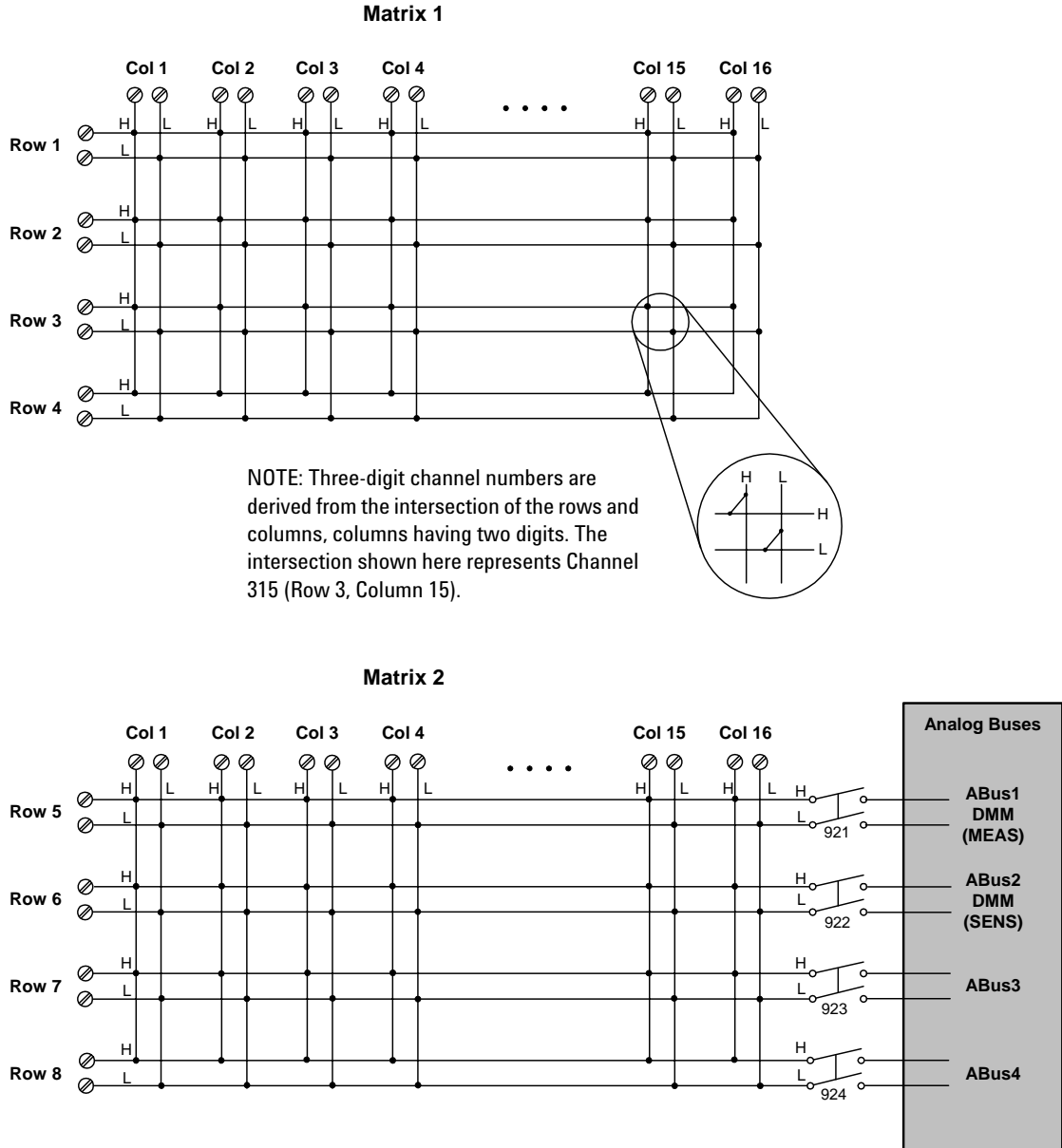

NOTE: Matrix 1 and Matrix 2 are electrically separate from one another.

NOTE:
 Matrix Relays: Armature latching
 Analog Bus Relays: Armature non-latching

34932A D-Sub Connectors

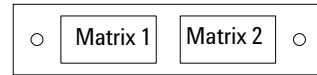

Matrix 1

For orientation, the D-sub connector end of the module is facing you.

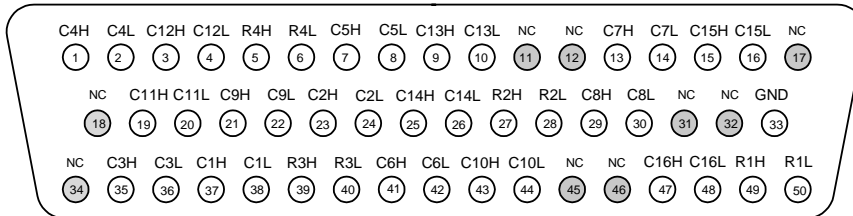

NOTE: In this diagram and the table below, R represents "row," and C represents "column."

50-Pin D-Sub Male Connector

Description	Pin	Description	Pin	Description	Pin	Description	Pin	Description	Pin
R1H	49	C2H	23	C7H	13	C12H	3	GND	33
R1L	50	C2L	24	C7L	14	C12L	4	No Connect pins: 11-12, 17-18, 31-32, 34, and 45-46	
R2H	27	C3H	35	C8H	29	C13H	9		
R2L	28	C3L	36	C8L	30	C13L	10		
R3H	39	C4H	1	C9H	21	C14H	25		
R3L	40	C4L	2	C9L	22	C14L	26		
R4H	5	C5H	7	C10H	43	C15H	15		
R4L	6	C5L	8	C10L	44	C15L	16		
C1H	37	C6H	41	C11H	19	C16H	47		
C1L	38	C6L	42	C11L	20	C16L	48		

Matrix 2

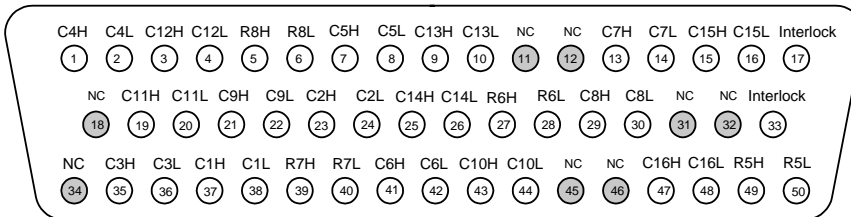

NOTE: In this diagram and the table below, R represents "row," and C represents "column."

50-Pin D-Sub Male Connector

WARNING As a safety feature, interlock pins (17 and 33) must be shorted to enable the Analog Bus relays, which are on Matrix 2, to close. The optional 34932T terminal block shorts these pins for you. This feature protects inadvertent routing of high voltages from the Analog Buses to the D-sub connector of the module.

Description	Pin	Description	Pin	Description	Pin	Description	Pin	Description	Pin
R5H	49	C2H	23	C7H	13	C12H	3	Interlock	17
R5L	50	C2L	24	C7L	14	C12L	4	Interlock	33
R6H	27	C3H	35	C8H	29	C13H	9	No connect pins: 11-12, 18, 31-32, 34, and 45-46.	
R6L	28	C3L	36	C8L	30	C13L	10		
R7H	39	C4H	1	C9H	21	C14H	25		
R7L	40	C4L	2	C9L	22	C14L	26		
R8H	5	C5H	7	C10H	43	C15H	15		
R8L	6	C5L	8	C10L	44	C15L	16		
C1H	37	C6H	41	C11H	19	C16H	47		
C1L	38	C6L	42	C11L	20	C16L	48		

34932T Terminal Block

This terminal block with screw-type connections is labeled with the model number and the abbreviated module name. In addition, space is available on the label for you to write the slot number.

NOTE

All modules that connect to the internal DMM are interlock protected. This means that when an installed module is exposed (no terminal block or cable is connected), the Analog Bus relays, which are on Matrix 2, are open and disconnected from the Analog Buses. See [page 2](#) for further information.

The *34980A Product Reference CD* (shipped with the instrument) contains a 34932T Wiring Log for you to document your wiring configuration for this module. You can open the wiring log file in Microsoft® Excel® or Adobe® Acrobat® format

Although they have separate screw-type connectors, rows labeled the same on a matrix are electrically connected. Therefore, you can wire the same-matrix rows in two locations.

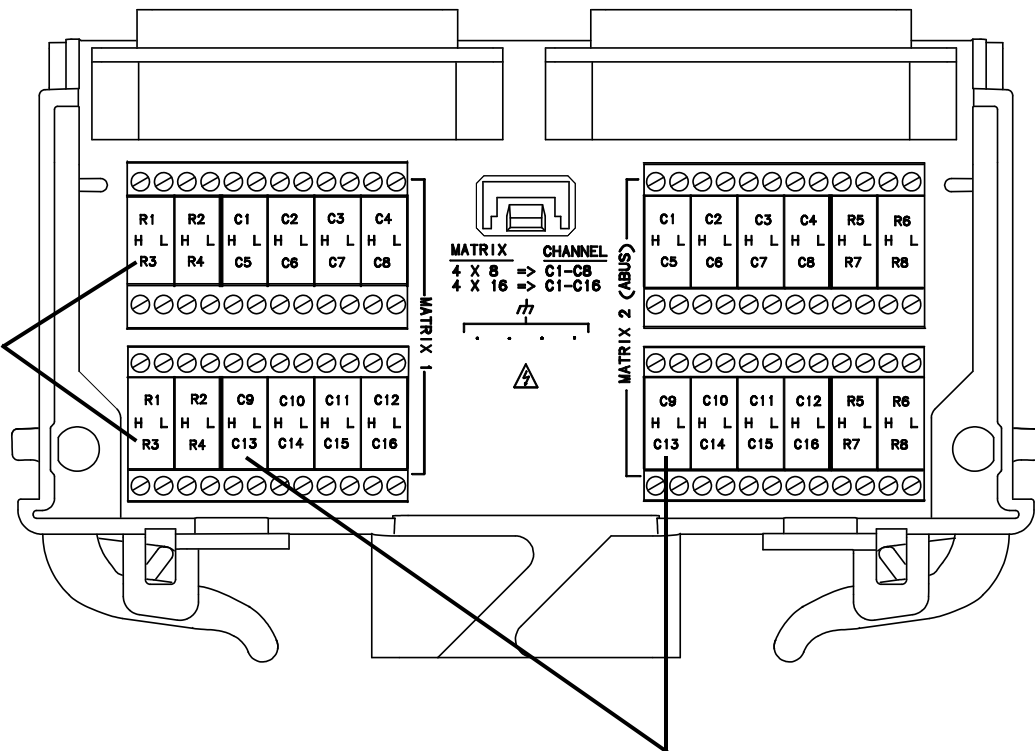

Wire Size:
20 AWG Typical
18 AWG Max

Although columns are numbered the same on Matrix 1 and Matrix 2, they are electrically separate from one another (e.g., Col C13).

34933A Dual/Quad 4x8 Reed Matrix

Using program commands or the front panel of the 34980A, you can configure the 34933A dual/quad 4x8 reed matrix module for differential (2-wire) mode or single-ended (1-wire) mode.

The 34933A module contains 100 Ω in-rush resistors that are used to protect the reed relays from reactive loads. If you have applications where in-rush resistors interfere with measurements, connections are provided on the terminal blocks for you to bypass the in-rush resistors that are located on the columns. See the simplified schematics on [page 19](#) and [page 23](#). However, if you choose to bypass the in-rush resistors, the life of the reed relays that you bypass may be degraded.

Two-Wire Mode

To physically configure the module for 2-wire mode, use the 34933T-001 terminal block, or a compatible standard or custom cable. If using a standard or custom cable, make sure you connect interlock pins 17 and 33 on the Matrix 2 D-sub connector. Refer to the pinout drawing and table on [page 20](#).

In 2-wire mode, the 34933A module contains two matrices, each with 32 2-wire crosspoint non-latching reed relays organized in a 4-row by 8-column configuration. Every row and column are made up of two wires each, a high (H) and a low (L). Each crosspoint relay has a unique channel number representing the row and column that intersect to create the crosspoint. For example, channel 308 represents the crosspoint connection between row 3 and column 08 (all columns consisting of two digits; in this case the digits are 08). See the simplified schematic on [page 19](#).

You can connect any combination of inputs and outputs at the same time. However, only Matrix 2 in 2-wire mode of this module connects to the Analog Buses. By closing channels 921 and 922 you can connect rows 5 and 6 respectively to the internal DMM of the 34980A mainframe for voltage and resistance measurements.

In 2-wire mode, you can close no more than 20 channels simultaneously due to power dissipation. However, note that Analog Bus relays count half as much as channel relays in that total. For example, with one Analog Bus relay closed, you can close up to a maximum of 19 channel relays. If you try to close more than the allowed number of channels, you will receive an error message.

One-Wire Mode

To physically configure the module in 1-wire mode, use the 34933T-002 terminal block, or a compatible standard or custom cable. If using a standard or custom cable, make sure you connect interlock pins 17 and 33 on the Matrix 2 D-sub connector. Refer to the pinout drawing and table on [page 24](#).

In 1-wire mode, the 34933A module contains four matrices (1 through 4), each with 32 1-wire crosspoint non-latching reed relays organized in a 4-row by 8-column configuration. Every row and column has one wire each. Each crosspoint relay has a unique channel number representing the matrix, and the single-wire row and column that intersect to make the crosspoint. For example, channel 218 represents Matrix 2, row 1 and column 8. See the simplified schematic on [page 23](#).

In 1-wire mode, you can close no more than 40 channels simultaneously due to power dissipation. For example, with one Analog Bus relay closed you can close up to a maximum of 39 channel relays. If you try to close more than the allowed number of channels, you will receive an error message.

You can connect any combination of inputs and outputs at the same time. However, only Matrix 3 and Matrix 4 in 1-wire mode of this module connect to the Analog Buses. By closing channels 921 and 922 you can connect rows 1 and rows 2 respectively to the internal DMM of the 34980A mainframe for voltage and resistance measurements.

You can connect multiple matrix modules externally and/or through the Analog Buses for applications that require large matrices. For information on linking multiple matrix modules, refer to [page 6](#) of this manual.

When the power is off, matrix relays and Analog Bus relays open.

34933A Simplified Schematic for Two-Wire Mode

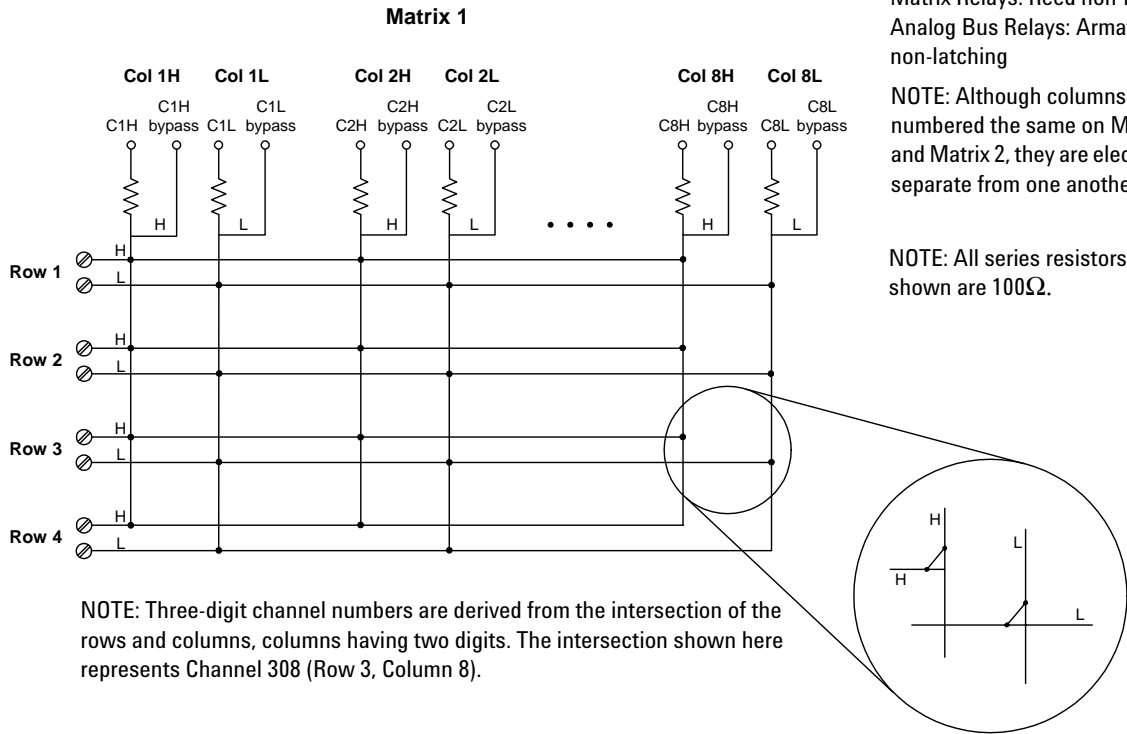

NOTE:
Matrix Relays: Reed non-latching
Analog Bus Relays: Armature non-latching

NOTE: Although columns are numbered the same on Matrix 1 and Matrix 2, they are electrically separate from one another.

NOTE: All series resistors shown are 100Ω.

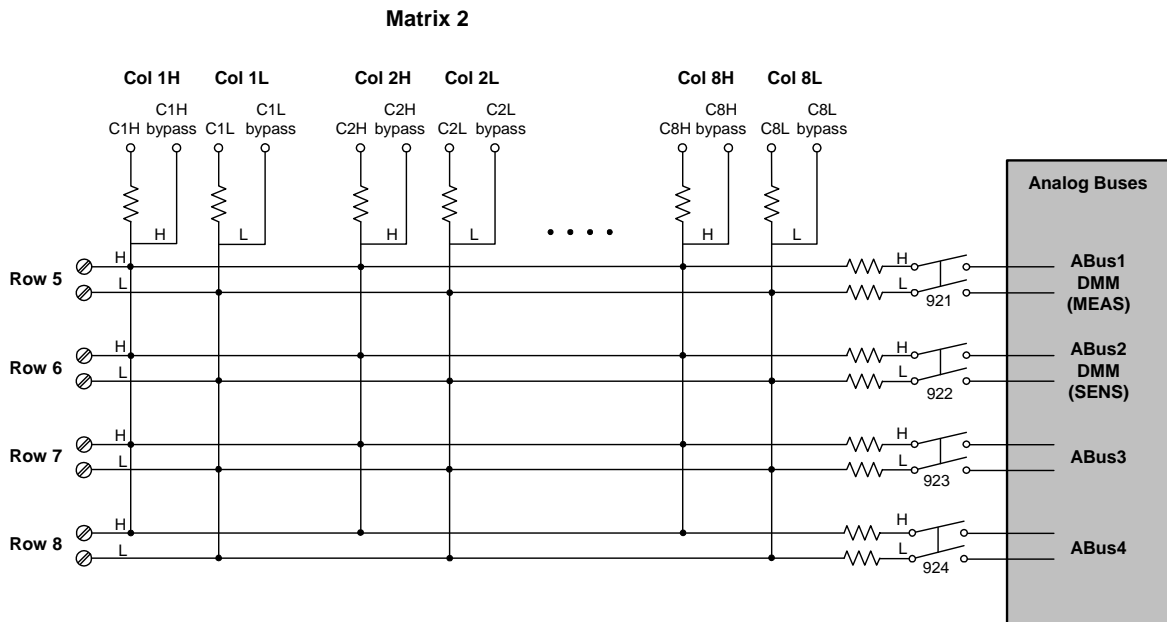

34933A D-Sub Connectors for Two-Wire Mode

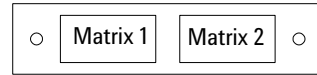

Matrix 1

For orientation, the D-sub connector end of the module is facing you.

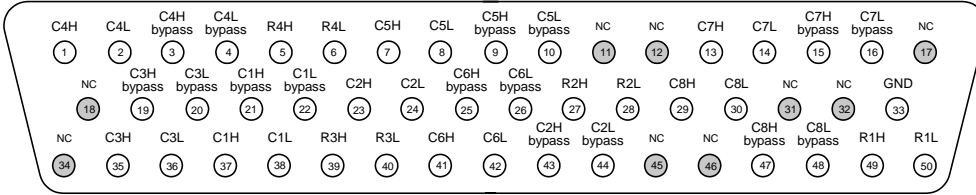

50-Pin D-Sub Male Connector

NOTE:

- In this diagram and the table below, R represents "row," and C represents "column."
- Bypass means to bypass the 100Ω in-rush resistor that protects the reed relays.

Description	Pin	Description	Pin	Description	Pin	Description	Pin	Description	Pin	Description	Pin
R1H	49	C1H	37	C5H	7	C1H bypass	21	C5H bypass	9	GND	33
R1L	50	C1L	38	C5L	8	C1L bypass	22	C5L bypass	10	No Connect pins: 11-12, 17-18, 31-32, 34, and 45-46	
R2H	27	C2H	23	C6H	41	C2H bypass	43	C6H bypass	25		
R2L	28	C2L	24	C6L	42	C2L bypass	44	C6L bypass	26		
R3H	39	C3H	35	C7H	13	C3H bypass	19	C7H bypass	15		
R3L	40	C3L	36	C7L	14	C3L bypass	20	C7L bypass	16		
R4H	5	C4H	1	C8H	29	C4H bypass	3	C8H bypass	47		
R4L	6	C4L	2	C8L	30	C4L bypass	4	C8L bypass	48		

Matrix 2

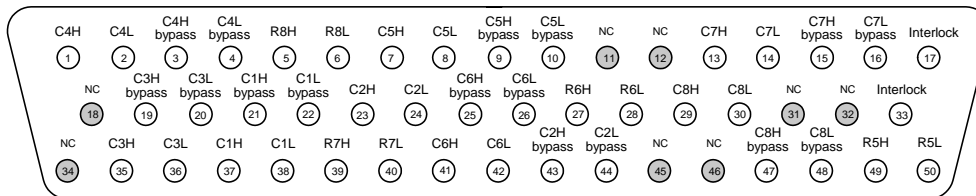

50-Pin D-Sub Male Connector

NOTE:

- In this diagram and the table below, R represents "row," and C represents "column."
- "Bypass" means to bypass the 100Ω in-rush resistor that protects the reed relays.

WARNING As a safety feature, interlock pins (17 and 33) must be shorted to enable the Analog Bus relays, which are on Matrix 2, to close. The optional 34933T-001 (for 2-wire) terminal block shorts these pins for you. This feature protects inadvertent routing of high voltages from the Analog Bus to the D-sub connector of the module.

Description	Pin	Description	Pin	Description	Pin	Description	Pin	Description	Pin
R5H	49	C2H	23	C7H	13	C4H bypass	3	Interlock	17
R5L	50	C2L	24	C7L	14	C4L bypass	4	Interlock	33
R6H	27	C3H	35	C8H	29	C5H bypass	9	No Connect pins: 11-12, 18, 31-32, 34, and 45-46	
R6L	28	C3L	36	C8L	30	C5L bypass	10		
R7H	39	C4H	1	C1H bypass	21	C6H bypass	25		
R7L	40	C4L	2	C1L bypass	22	C6L bypass	26		
R8H	5	C5H	7	C2H bypass	43	C7H bypass	15		
R8L	6	C5L	8	C2L bypass	44	C7L bypass	16		
C1H	37	C6H	41	C3H bypass	19	C8H bypass	47		
C1L	38	C6L	42	C3L bypass	20	C8L bypass	48		

34933T-001 Terminal Block for Two-Wire Mode

This terminal block with screw-type connections is labeled with the model number and the abbreviated module name. In addition, space is available on the label for you to write the slot number.

NOTE

All modules that connect to the internal DMM are interlock protected. This means that when an installed module is exposed (no terminal block or cable is connected), the Analog Bus relays, which are on Matrix 2, are open and disconnected from the Analog Buses. See [page 2](#) for further information.

The *34980A Product Reference* CD (shipped with the instrument) contains a 34933T (2-wire) Wiring Log for you to document your wiring configuration for this module. You can open the wiring log file in Microsoft® Excel® or Adobe® Acrobat® format

NOTE

If you are using an Agilent terminal block to connect your DUT to this module be sure to use the 34933T-001 terminal block that corresponds to the 2-wire configuration mode. Note that an error will not be generated if you have installed a terminal block that doesn't match the present module configuration.

34933A Dual/Quad 4x8 Reed Matrix

Although columns are numbered the same on Matrix 1 and Matrix 2, they are electrically separate from one another (e.g., Col C2).

Wire Size:
20 AWG Typical
18 AWG Max

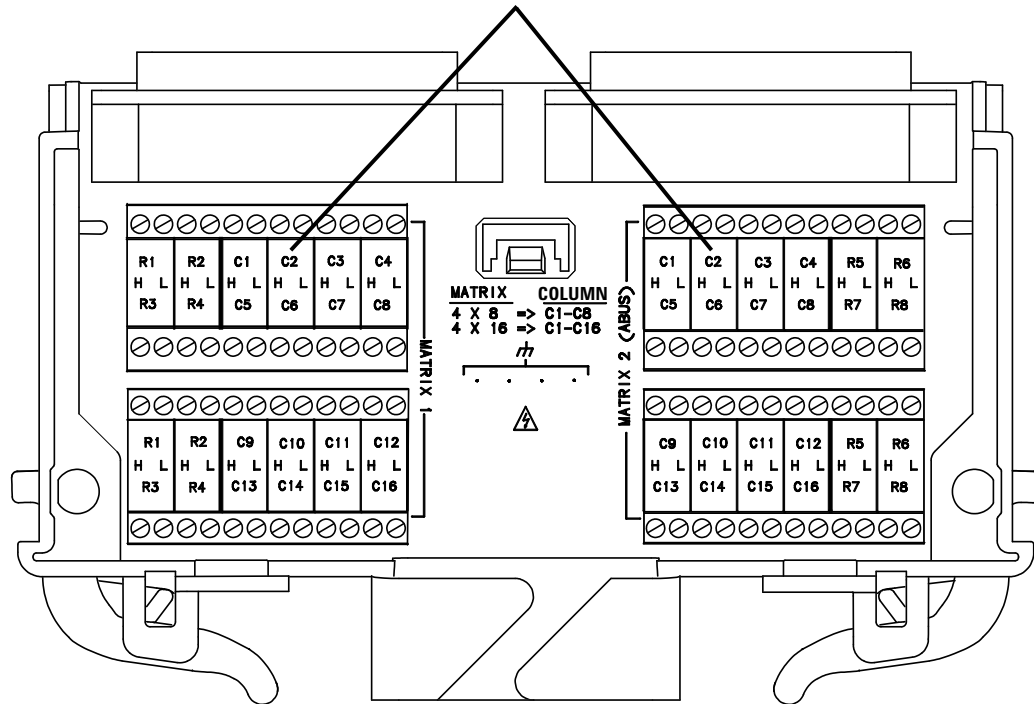

When using the 34933T terminal block for 2-wire mode, access is provided to the bypass columns through the columns labeled C9 through C16. Follow this wiring convention shown in the table below for both matrices.

Terminal marked...	Connects to...	Terminal marked...	Connects to...
C9H	C1Hbypass	C13H	C5H bypass
C9L	C1L bypass	C13L	C5L bypass
C10H	C2H bypass	C14H	C6H bypass
C10L	C2L bypass	C14L	C6L bypass
C11H	C3H bypass	C15H	C7H bypass
C11L	C3L bypass	C15L	CC7L bypass
C12H	C4H bypass	C16H	C8H bypass
C12L	C4L bypass	C16L	C8L bypass

34933A Simplified Schematic for One-Wire Mode

NOTE: Although rows are numbered the same across the matrices, they are electrically separate from one another.

NOTE:
Matrix Relays: Reed non-latching
Analog Bus Relays: Armature non-latching

NOTE: All series resistors shown are 100Ω.

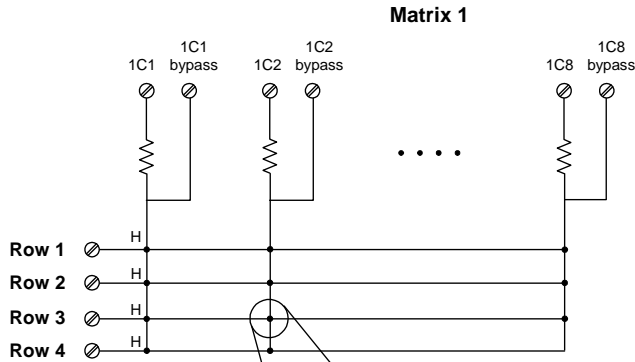

NOTE: Three-digit channel numbers are derived from a specific matrix number and the intersection of rows and columns on that matrix. The channel shown here is 132 (Matrix 1, Row 3, Column 2.)

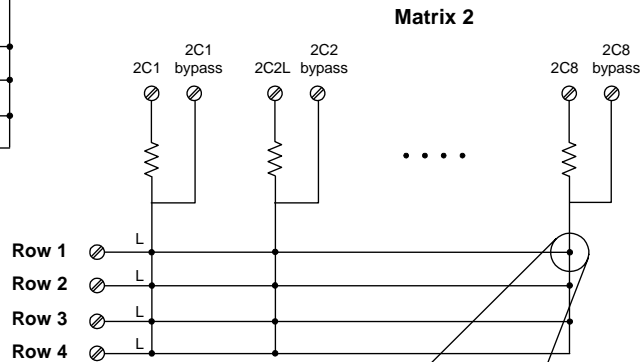

Channel 218
(Matrix 2, Row 1, Column 8)

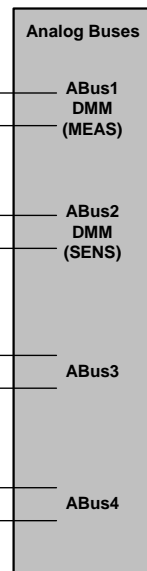
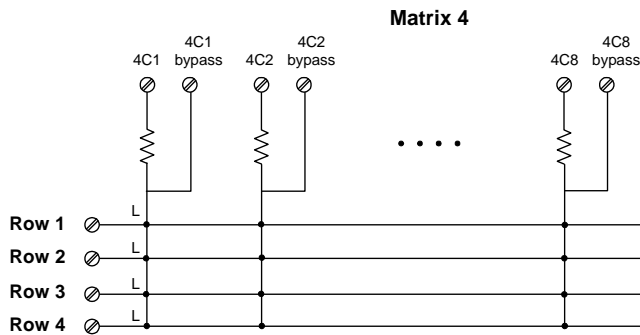
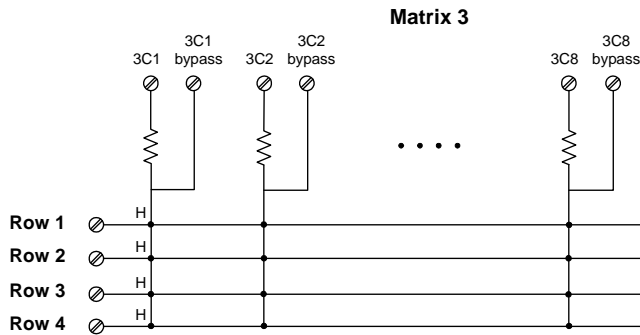

34933A D-Sub Connectors for One-Wire Mode

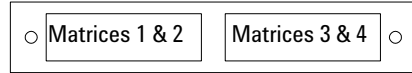

Matrices 1 and 2

For orientation, the D-sub connector end of the module is facing you.

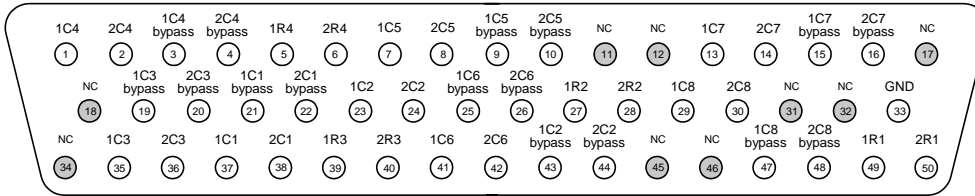

50-Pin D-Sub Male Connector

NOTE: Conventions for these drawings and tables as they relate to pinout information:

- **2R4** means Matrix **2**, Row **4**.
- **1C5** means Matrix **1**, Column **5**
- **4C2 bypass** means: Matrix **4**, Column **2**, and the connection bypasses the 100Ω in-rush resistor that protects the reed relays

Description	Pin	Description	Pin	Description	Pin	Description	Pin	Description	Pin
1R1	49	1C2	23	1C7	13	1C4 bypass	3	GND	33
1R2	27	2C2	24	2C7	14	2C4 bypass	4	No connect pins: 11-12, 17-18, 31-32, 34, and 45-46	
1R3	39	1C3	35	1C8	29	1C5 bypass	9		
1R4	5	2C3	36	2C8	30	2C5 bypass	10		
2R1	50	1C4	1	1C1 bypass	21	1C6 bypass	25		
2R2	28	2C4	2	2C1 bypass	22	2C6 bypass	26		
2R3	40	1C5	7	1C2 bypass	43	1C7 bypass	15		
2R4	6	2C5	8	2C2 bypass	44	2C7 bypass	16		
1C1	37	1C6	41	1C3 bypass	19	1C8 bypass	47		
2C1	38	2C6	42	2C3 bypass	20	2C8 bypass	48		

Matrices 3 and 4

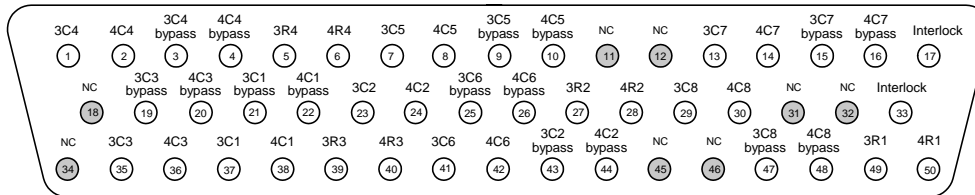

50-Pin D-Sub Male Connector

WARNING As a safety feature, interlock pins (17 and 33) must be shorted to enable the Analog Bus relays, which are on Matrix 2, to close. The optional 34933T-002 (for 1-wire) terminal block shorts these pins for you. This safety feature protects inadvertent routing of high voltages from the Analog Buses to the D-sub connector of the module.

Description	Pin	Description	Pin	Description	Pin	Description	Pin	Description	Pin
3R1	49	3C2	23	3C7	13	3C4 bypass	3	Interlock	17
3R2	27	4C2	24	4C7	14	4C4 bypass	4	Interlock	33
3R3	39	3C3	35	3C8	29	3C5 bypass	9	No connect pins: 11-12, 18, 31-32, 34, and 45-46	
3R4	5	4C3	36	4C8	30	4C5 bypass	10		
4R1	50	3C4	1	3C1 bypass	21	3C6 bypass	25		
4R2	28	4C4	2	4C1 bypass	22	4C6 bypass	26		
4R3	40	3C5	7	3C2 bypass	43	3C7 bypass	15		
4R4	6	4C5	8	4C2 bypass	44	4C7 bypass	16		
3C1	37	3C6	41	3C3 bypass	19	3C8 bypass	47		
4C1	38	4C6	42	4C3 bypass	20	4C8 bypass	48		

34933T-002 Terminal Block for One-Wire Mode

This terminal block with screw-type connections is labeled with the model number and the abbreviated module name. In addition, space is available on the label for you to write the slot number.

NOTE

All modules that connect to the internal DMM are interlock protected. This means that when an installed module is exposed (no terminal block or cable is connected), the Analog Bus relays and current channels are open and disconnected from the Analog Buses. See [page 2](#) for further information.

The *34980A Product Reference* CD (shipped with the instrument) contains a 34933T (1-wire) Wiring Log for you to document your wiring configuration for this module. You can open the wiring log file in Microsoft® Excel® or Adobe® Acrobat® format

NOTE

If you are using an Agilent terminal block to connect your DUT to this module be sure to use the 34933T-002 terminal block that corresponds to the 1-wire configuration mode. Note that an error will not be generated if you have installed a terminal block that doesn't match the present module configuration.

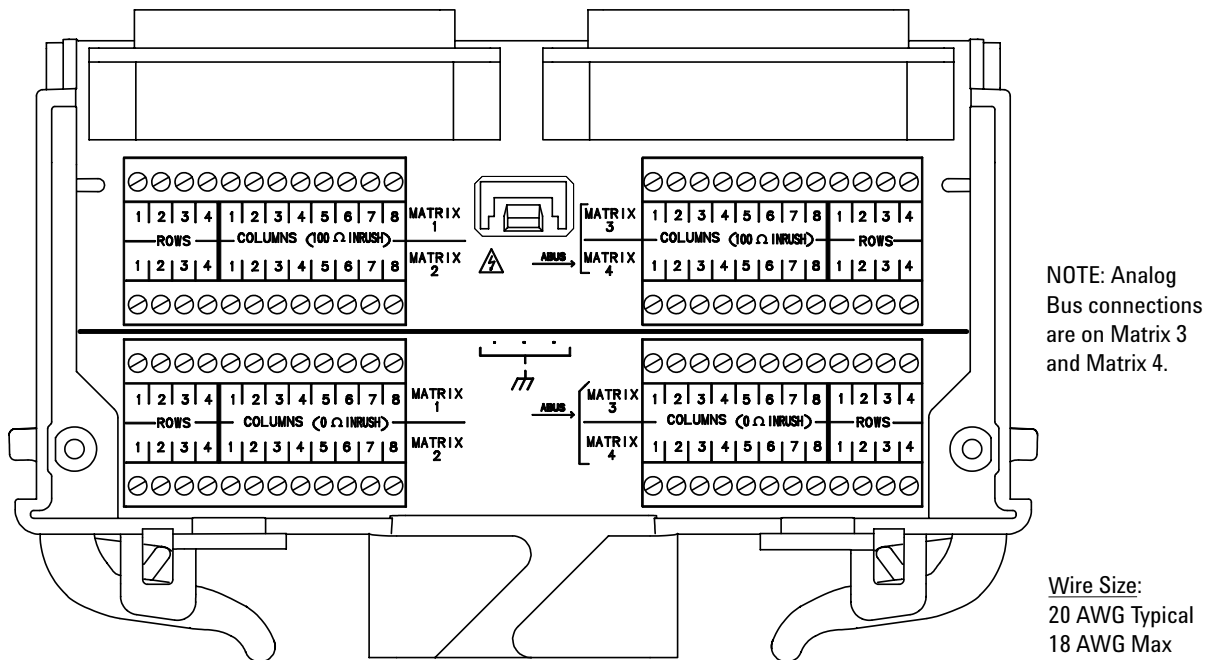

34933A Dual/Quad 4x8 Reed Matrix

Index

Numerics

- 34931A
 - channel numbering, 3
 - connector pinouts, 10
 - description, 8
 - linking multiple modules, 6
 - programming examples, 3
 - simplified schematic, 9
 - terminal block, 11
 - wiring log, 11
- 34932A
 - channel numbering, 3
 - connector pinouts, 15
 - description, 13
 - linking multiple modules, 6
 - programming examples, 3
 - simplified schematic, 14
 - terminal block, 16
 - wiring log, 16
- 34933A
 - channel numbering, 3
 - connector pinouts, 20, 24
 - description, 17
 - linking multiple modules, 6
 - programming examples, 3
 - simplified schematic, 19, 23
 - terminal block, 21, 25
 - wiring log, 21, 25

C

- connector pinouts
 - 34931A, 10
 - 34932A, 15
 - 34933A, 20, 24

D

- D-sub pinouts
 - 34931A, 10
 - 34932A, 15
 - 34933A, 20, 24

O

- operating considerations, 2

P

- pinouts
 - 34931A, 10
 - 34932A, 15
 - 34933A, 20, 24

W

- warranty, ii

