

Keysight 53147A/148A/149A Microwave Frequency Counter/Power Meter/DVM

Assembly Level
Service Guide

Notices

Copyright Notice

© Keysight Technologies 2001 - 2017
No part of this manual may be reproduced in any form or by any means (including electronic storage and retrieval or translation into a foreign language) without prior agreement and written consent from Keysight Technologies as governed by United States and international copyright laws.

Manual Part Number

53147-90010

Edition

Edition 3, November 1, 2017

Printed in:

Printed in Malaysia

Published by:

Keysight Technologies
Bayan Lepas Free Industrial Zone,
11900 Penang, Malaysia

Technology Licenses

The hardware and/or software described in this document are furnished under a license and may be used or copied only in accordance with the terms of such license.

Declaration of Conformity

Declarations of Conformity for this product and for other Keysight products may be downloaded from the Web. Go to <http://www.keysight.com/go/conformity>. You can then search by product number to find the latest Declaration of Conformity.

U.S. Government Rights

The Software is “commercial computer software,” as defined by Federal Acquisition Regulation (“FAR”) 2.101. Pursuant to FAR 12.212 and 27.405-3 and Department of Defense FAR Supplement (“DFARS”) 227.7202, the U.S. government acquires commercial computer software under the same terms by which the software is customarily provided to the public. Accordingly, Keysight provides the Software to U.S. government customers under its standard commercial license, which is embodied in its End User License Agreement (EULA), a copy of which can be found at <http://www.keysight.com/find/sweula>. The license set forth in the EULA represents the exclusive authority by which the U.S. government may use, modify, distribute, or disclose the Software. The EULA and the license set forth therein, does not require or permit, among other things, that Keysight: (1) Furnish technical information related to commercial computer software or commercial computer software documentation that is not customarily provided to the public; or (2) Relinquish to, or otherwise provide, the government rights in excess of these rights customarily provided to the public to use, modify, reproduce, release, perform, display, or disclose commercial computer software or commercial computer software documentation. No additional government requirements beyond those set forth in the EULA shall apply, except to the extent that those terms, rights, or licenses are explicitly required from all providers of commercial computer software pursuant to the FAR and the DFARS and are set forth specifically in writing elsewhere in the EULA. Keysight shall be under no obligation to update, revise or otherwise modify the Software. With respect to any technical data as defined by FAR 2.101, pursuant to FAR 12.211 and 27.404.2 and DFARS 227.7102, the U.S. government acquires no greater than Limited Rights as defined in FAR 27.401 or DFAR 227.7103-5 (c), as applicable in any technical data.

Warranty

THE MATERIAL CONTAINED IN THIS DOCUMENT IS PROVIDED “AS IS,” AND IS SUBJECT TO BEING CHANGED, WITHOUT NOTICE, IN FUTURE EDITIONS. FURTHER, TO THE MAXIMUM EXTENT PERMITTED BY APPLICABLE LAW, KEYSIGHT DISCLAIMS ALL WARRANTIES, EITHER EXPRESS OR IMPLIED, WITH REGARD TO THIS MANUAL AND ANY INFORMATION CONTAINED HEREIN, INCLUDING BUT NOT LIMITED TO THE IMPLIED WARRANTIES OF MERCHANTABILITY AND FITNESS FOR A PARTICULAR PURPOSE. KEYSIGHT SHALL NOT BE LIABLE FOR ERRORS OR FOR INCIDENTAL OR CONSEQUENTIAL DAMAGES IN CONNECTION WITH THE FURNISHING, USE, OR PERFORMANCE OF THIS DOCUMENT OR OF ANY INFORMATION CONTAINED HEREIN. SHOULD KEYSIGHT AND THE USER HAVE A SEPARATE WRITTEN AGREEMENT WITH WARRANTY TERMS COVERING THE MATERIAL IN THIS DOCUMENT THAT CONFLICT WITH THESE TERMS, THE WARRANTY TERMS IN THE SEPARATE AGREEMENT SHALL CONTROL.

Safety Information

CAUTION

A CAUTION notice denotes a hazard. It calls attention to an operating procedure, practice, or the like that, if not correctly performed or adhered to, could result in damage to the product or loss of important data. Do not proceed beyond a CAUTION notice until the indicated conditions are fully understood and met.

WARNING

A WARNING notice denotes a hazard. It calls attention to an operating procedure, practice, or the like that, if not correctly performed or adhered to, could result in personal injury or death. Do not proceed beyond a WARNING notice until the indicated conditions are fully understood and met.

Serial Prefix Number

This guide describes how to service the Keysight 53147A, 53148A, and 53149A. The information in this guide applies to instruments having the number prefix listed below, unless accompanied by a “Manual Updating Changes” package indicating otherwise.

SERIAL PREFIX NUMBER: **US4047 (53147A)**
 US4048 (53148A)
 US4049 (53149A)

Certification and Warranty

Certification

Keysight Technologies certifies that this product met its published specification at the time of shipment from the factory. Keysight further certifies that its calibration measurements are traceable to the United States National Institute of Standards and Technology (formerly National Bureau of Standards), to the extent allowed by the Institute’s calibration facility, and to the calibration facilities of other International Standards Organization members.

Warranty

Keysight warrants Keysight hardware, accessories and supplies against defects in materials and workmanship for a period of one year from date of shipment. If Keysight receives notice of such defects during the warranty period, Keysight will, at its option, either repair or replace products which prove to be defective. Replacement products may be either new or like-new.

Keysight warrants that Keysight software will not fail to execute its programming instructions, for the period specified above, due to defects in material and workmanship when properly installed and used. If Keysight receives notice of such defects during the warranty period, Keysight will replace software media which does not execute its programming instructions due to such defects.

Keysight does not warrant that the operation of Keysight products will be uninterrupted or error free. If Keysight is unable, within a reasonable time, to repair or replace any product to a condition as warranted, customer will be entitled to a refund of the purchase price upon prompt return of the product.

Keysight products may contain remanufactured parts equivalent to new in performance or may have been subjected to incidental use.

The warranty period begins on the date of delivery or on the date of installation if installed by Keysight. If customer schedules or delays Keysight installation more than 30 days after delivery, warranty begins on the 31st day from delivery.

Warranty does not apply to defects resulting from (a) improper or inadequate maintenance or calibration, (b) software, interfacing, parts or supplies not supplied by Keysight, (c) unauthorized modification or misuse, (d) operation outside of the published environmental specifications for the product, or (e) improper site preparation or maintenance.

TO THE EXTENT ALLOWED BY LOCAL LAW, THE ABOVE WARRANTIES ARE EXCLUSIVE AND NO OTHER WARRANTY OR CONDITION, WHETHER WRITTEN OR ORAL, IS EXPRESSED OR IMPLIED AND Keysight SPECIFICALLY DISCLAIMS ANY IMPLIED WARRANTIES OR CONDITIONS OF MERCHANTABILITY, SATISFACTORY QUALITY, AND FITNESS FOR A PARTICULAR PURPOSE.









Keysight will be liable for damage to tangible property per incident up to the greater of \$300,000 or the actual amount paid for the product that is the subject of the claim, and for damages for bodily injury or death, to the extent that all such damages are determined by a court of competent jurisdiction to have been directly caused by a defective Keysight product.

TO THE EXTENT ALLOWED BY LOCAL LAW, THE REMEDIES IN THIS WARRANTY STATEMENT ARE CUSTOMER'S SOLE AND EXCLUSIVE REMEDIES. EXCEPT AS INDICATED ABOVE, IN NO EVENT WILL Keysight OR ITS SUPPLIERS BE LIABLE FOR LOSS OF DATA OR FOR DIRECT, SPECIAL, INCIDENTAL, CONSEQUENTIAL (INCLUDING LOST PROFIT OR DATA), OR OTHER DAMAGE, WHETHER BASED IN CONTRACT, TORT, OR OTHERWISE.

For consumer transactions in Australia and New Zealand: the warranty terms contained in this statement, except to the extent lawfully permitted, do not exclude, restrict or modify and are in addition to the mandatory statutory rights applicable to the sale of this product to you.

Safety Symbols

The following symbols on the instrument and in the documentation indicate precautions which must be taken to maintain safe operation of the instrument.

	Direct current (DC)		Alternating current (AC)
	Caution, risk of danger (refer to this manual for specific Warning or Caution information)		Caution, risk of electric shock
	Earth (ground) terminal		Frame or chassis (ground) terminal
	Alternating current (AC)		Direct current (DC)

Safety Considerations

Read the information below before using this instrument.

The following general safety precautions must be observed during all phases of operation, service, and repair of this instrument. Failure to comply with these precautions or with specific warnings elsewhere in this manual violates safety standards for design, manufacture, and intended use of the instrument. Keysight Technologies assumes no liability for the customer's failure to comply with these requirements.

Safety Earth Ground

An uninterruptible safety earth ground must be maintained from the mains power source to the product's ground circuitry.

WARNING

WHEN MEASURING POWER LINE SIGNALS, BE EXTREMELY CAREFUL AND ALWAYS USE A STEP-DOWN ISOLATION TRANSFORMER WHICH OUTPUT IS COMPATIBLE WITH THE INPUT MEASUREMENT CAPABILITIES OF THIS PRODUCT. THIS PRODUCT'S FRONT AND REAR PANELS ARE TYPICALLY AT EARTH GROUND. THUS, NEVER TRY TO MEASURE AC POWER LINE SIGNALS WITHOUT AN ISOLATION TRANSFORMER.

WARNING

INSTRUCTIONS FOR ADJUSTMENTS WHILE COVERS ARE REMOVED AND FOR SERVICING ARE FOR USE BY SERVICE-TRAINED PERSONNEL ONLY. TO AVOID DANGEROUS ELECTRIC SHOCK, DO NOT PERFORM SUCH ADJUSTMENTS OR SERVICING UNLESS QUALIFIED TO DO SO.

WARNING

ANY INTERRUPTION OF THE PROTECTIVE GROUNDING CONDUCTOR (INSIDE OR OUTSIDE THE PRODUCT'S CIRCUITRY) OR DISCONNECTING THE PROTECTIVE EARTH TERMINAL WILL CAUSE A POTENTIAL SHOCK HAZARD THAT COULD RESULT IN PERSONAL INJURY. (GROUNDING ONE CONDUCTOR OF A TWO CONDUCTOR OUTLET IS NOT SUFFICIENT PROTECTION.)

Whenever it is likely that the protection has been impaired, the instrument must be made inoperative and be secured against any unintended operation.

If this instrument is to be energized via an autotransformer (for voltage reduction), make sure the common terminal is connected to the earthed pole terminal (neutral) of the power source.

Instructions for adjustments while covers are removed and for servicing are for use by trained personnel only. To avoid dangerous electric shock, do not perform such adjustments or servicing unless qualified to do so.

For continued protection against fire, replace the line fuse(s) with fuses of the same current rating and type (for example, normal blow, time delay). Do not use repaired fuses or short-circuited fuseholders.

Acoustic Noise Emissions

LpA<47 dB at operator position, at normal operation, tested per EN 27779. All data are the results from type test.

Geräuschemission

LpA<47 dB am Arbeits
platz, normaler Betrieb, geprüft nach EN 27779.
Die Angaben beruhen auf Ergebnissen von Typenprüfungen.

Electrostatic Discharge Immunity Testing

When the product is tested with 8kV AD, 4kV CD and 4kV ID according to IEC801-2, a system error may occur that may affect measurement data made during these disturbances. After these occurrences, the system self-recovers without user intervention.

Waste Electrical and Electronic Equipment (WEEE) Directive

This instrument complies with the WEEE Directive marking requirement. This affixed product label indicates that you must not discard this electrical or electronic product in domestic household waste.

Product category:

With reference to the equipment types in the WEEE directive Annex 1, this instrument is classified as a “Monitoring and Control Instrument” product.

The affixed product label is as shown below.



Do not dispose in domestic household waste.

To return this unwanted instrument, contact your nearest Keysight Service Center, or visit <http://about.keysight.com/en/companyinfo/environment/takeback.shtml> for more information.

Sales and Technical Support

To contact Keysight for sales and technical support, refer to the support links on the following Keysight websites:

- www.keysight.com/find/counters
(product-specific information and support, software and documentation updates)
- www.keysight.com/find/assist
(worldwide contact information for repair and service)

Table of Contents

Serial Prefix Number	3
Certification and Warranty	3
Certification	3
Warranty	3
Safety Symbols	5
Safety Considerations	6
Safety Earth Ground	6
Acoustic Noise Emissions	7
Geräuschemission	7
Electrostatic Discharge Immunity Testing	7
Waste Electrical and Electronic Equipment (WEEE) Directive	8
Product category:	8
Sales and Technical Support	8
List of Figures	13
List of Tables	15
1 Performance Tests - Verifying Specifications	
Introduction	18
Operational Verification	18
Complete Performance Tests	18
Recommended Calibration Cycle	19
Test Record	19
Equipment Required	20
Operational Verification	22
Power-On Self Tests	22
10 MHz Test	23
Run Self Test	24
External Timebase Test	24
Power Meter Test	26
DVM Test	28

Complete Performance Tests	30
Test 1: Channel 1 Frequency Sensitivity	31
Test 1a: 10 Hz to 20 MHz Frequency Sensitivity	31
Test 1b: 50 MHz to 125 MHz Frequency Sensitivity	33
Test 2: Channel 2 Frequency Sensitivity	35
Test 2a: 50 MHz to 20 GHz Frequency Sensitivity	35
Test 2b: 22 GHz to 26.5 GHz Frequency Sensitivity	37
Test 2c: 30 GHz to 46 GHz Frequency Sensitivity	38
Test 3: Power Measurement	39
Power Measurement Accuracy Test	39
Test 4: Power Reference Oscillator Frequency	42
Power Reference Oscillator Frequency Test	42
Test 5: Power Meter Reference Level	44
Power Meter Reference Level: Method 1	44
Power Meter Reference Level: Method 2	46
Performance Test Record (Page 1 of 3)	51
Performance Test Record (Page 2 of 3)	52
Performance Test Record (Page 3 of 3)	53

2 Service

Introduction	56
Returning the Instrument to Keysight Technologies for Service	57
Providing Repair Information	57
Packing the Instrument in the Original Packaging Materials	58
Packing the Instrument in Commercially Available Packaging Materials	58
Calibration Procedures	59
Equipment Required	59
10 MHz Timebase Calibration	60
Power Reference Oscillator Frequency Calibration	62
Power Reference Oscillator Level Adjustment	66
DVM Calibration	73
Pre-Troubleshooting Information	76

Safety Considerations	76
Recommended Test Equipment	77
Repair Considerations	77
After Service Considerations	78
Assembly Identification and Location	79
Troubleshooting the Instrument	81
Power Supply Check	81
Self-Test	83
3 Replacing Assemblies - Disassembly and Reassembly	
Introduction	90
Tools Required	91
Do This First	92
Removing the Bumpers	93
Removing the Handle	94
Removing the Bumper Retainers	95
Removing the Shroud	96
Removing the Front Panel Assembly	98
Removing the Rear Panel Assembly	101
Removing the Cooling Fan	103
Removing the Power Supply	104
4 Replaceable Parts	
Introduction	108
Replaceable Parts	109
How To Order A Part	110
Contacting Keysight Technologies	111
Parts Identification	112
Reference Designations	112
Cabinet Parts and Hardware	112
Accessories and Miscellaneous Items	112
5 Backdating	

	Introduction	122
6	Specifications	
A	Rack Mounting the Instrument	
	Rack Mounting the Instrument	126
	Index	131

List of Figures

Figure 1-1	External Timebase Test Setup	25
Figure 1-2	DVM Test Setup	28
Figure 1-3	10 Hz to 20 MHz Frequency Sensitivity Test Setup	32
Figure 1-4	50 MHz to 125 MHz Frequency Sensitivity Test Setup	33
Figure 1-5	50 MHz to 20 GHz Frequency Sensitivity Test Setup	36
Figure 1-6	Power Measurement Accuracy Test Setup	39
Figure 1-7	Reference Oscillator Frequency Adjustment Setup	43
Figure 1-8	E4418B Power Meter Zeroing and Calibration Test Setup	44
Figure 1-9	Power Meter Reference Level Test Setup	45
Figure 1-10	Keysight 8120-1082 Power Sensor Cable End View	46
Figure 1-11	Power Meter Reference Level Test Setup	47
Figure 2-1	Calibrating the 10 MHz Frequency Reference Oscillator	61
Figure 2-2	Reference Oscillator Frequency Adjustment Setup	63
Figure 2-3	Power Reference Oscillator Adjustment Locations	65
Figure 2-4	E4418B Power Meter Zeroing and Calibration Test Setup	66
Figure 2-5	Power Meter Reference Level Test Setup	67
Figure 2-6	Keysight 8120-1082 Power Sensor Cable End View	68
Figure 2-7	Power Meter Reference Level Calibration Setup	69
Figure 2-8	DVM Tests Main Menu	74
Figure 2-9	Replaceable Assembly Locations – Top Internal View	80
Figure 2-10	A4 DC Power Supply Test-Point Locations	81
Figure 3-1	Removing the Bumpers	93
Figure 3-2	Removing the Handle	94
Figure 3-3	Removing the Bumper Retainers	95
Figure 3-4	Removing the Shroud	97
Figure 3-5	Removing the Front Panel Assembly	99
Figure 3-6	Rear Panel Assembly Screws	101
Figure 3-7	Cooling Fan Screws	103
Figure 3-8	Removing the Power Supply	104
Figure 4-1	Keysight 53147A/148A/149A Exploded View – Internal	

	Parts	113
Figure 4-2	Keysight 53147A/148A/149A Exploded View – Cabinet and External Parts	114
Figure 4-3	Keysight 53147A/148A/149A Top View	115

List of Tables

Table 1-1	Recommended Test Equipment and Accessories	20
Table 1-2	Complete Performance Tests	30
Table 1-3	Range Calibrator Settings and Expected Results	41
Table 2-1	Recommended Test Equipment and Accessories	59
Table 2-2	Keysight 53147A/148A/149A Assembly Identification	79
Table 2-3	A4 Power Supply Inputs and Outputs	82
Table 2-4	Self-Test Messages	84
Table 2-5	Front Panel Display Error Messages	85
Table 2-6	RS-232 Error Messages	86
Table 4-1	Reference Designations	112
Table 4-2	Keysight 53147A/148A/149A Replaceable Parts	116
Table 4-3	Keysight 53147A/148A/149A Accessories and Miscellaneous Items	119

THIS PAGE HAS BEEN INTENTIONALLY LEFT BLANK.

1 Performance Tests – Verifying Specifications

Introduction	18
Equipment Required	20
Operational Verification	22
Complete Performance Tests	30
Test 1: Channel 1 Frequency Sensitivity	31
Test 2: Channel 2 Frequency Sensitivity	35
Test 3: Power Measurement	39
Test 4: Power Reference Oscillator Frequency	42
Test 5: Power Meter Reference Level	44
Performance Test Record (Page 1 of 3)	51
Performance Test Record (Page 2 of 3)	52
Performance Test Record (Page 3 of 3)	53

Introduction

This chapter provides procedures to test the electrical performance of the Keysight 53147A, 53148A, and 53149A. These procedures are based on the specifications in Chapter 6, “Specifications”.

Two types of testing are provided:

- Operational Verification
- Complete Performance Tests

This chapter is organized as follows:

- “Introduction” pg. 18
- “Equipment Required” pg. 20
- “Operational Verification” pg. 22
- “Complete Performance Tests” pg. 30
- “Performance Test Record” pg. 51

Operational Verification

Operational Verification is an abbreviated series of tests that you can perform (instead of performing the Complete Performance Tests) to provide a high degree of confidence that the instrument is operating properly. Operational Verification is useful for incoming inspection, routine maintenance, and after instrument repair.

Complete Performance Tests

The Complete Performance Tests verify the specifications listed in Chapter 6, “Specifications”. All tests can be performed without opening the instrument.

Recommended Calibration Cycle

The instrument requires periodic verification of operation. Depending on the type of use, environmental conditions, aging, and measurement accuracy required, the instrument should be checked using the operational verification procedure at least once every year. A full Calibration and Performance Test should be performed each time the instrument changes environment or if an assembly or module has been replaced.

Test Record

The results of the Operational Verification and the Complete Performance Tests should be recorded on a copy of the Performance Test Record, located at the end of the **“Complete Performance Tests”** section in this chapter.

Equipment Required

Table 1-1 lists the test equipment and accessories needed to perform the tests in this chapter.

Table 1-1 Recommended Test Equipment and Accessories

Instrument Type	Required Characteristics	Model Recommended ^[a]	Quantity Required	Use ^[b]
Synthesized Signal Generator	10 Hz to 20 MHz, +7 dBm to -40 dBm	Keysight 3325A/B	2	OV, P, T
Microwave Synthesized Signal Generator	10 MHz to 50 GHz, Accuracy $>1 \times 10^{-10}$ +7 dBm to -50 dBm	Keysight 83650B	1	P, T
Microwave Amplifier	45 MHz to 50 GHz	Keysight 83051A	1	P, T
Digital Multimeter	6½ digit AC/DC	Keysight 34401A	1	OV, P
DC Power Supply	25 VDC	Keysight E3640A	1	OV
Frequency Counter	10 Hz to 125 MHz	Keysight 53150A/51A/52A	1	P, C, T
Power Meter	Range 1 mW	Keysight 432A	1	P, C, T
Power Meter	50 MHz to 50 GHz, +13 dBm to -50 dBm	Keysight 437B	1	P, C, T
Power Meter	100 kHz to 110 GHz, -70 dBm to +44 dBm	Keysight E4418B	1	P, C, T
Thermistor Mount	SWR 1.05 at 50 MHz Accuracy $\pm 0.5\%$ at 50 MHz	Keysight 478A-H75 or 478A-H76	1	P, T
Power Sensor	10 MHz to 18 GHz, -30 dBm to +20 dBm	Keysight 8481A	1	P, T
Power Sensor	50 MHz to 50 GHz, +13 dBm to -50 dBm	Keysight 8487A	1	P, C, T
Power Sensor Cable	2.4 mm to 2.4 mm, 5 ft.	Keysight 11730A	2 ^[c]	P, T
Power Sensor Cable		Keysight 8120-1082	1	P, T
Range Calibrator	3, 10, 30, 100, and 300 μ W 1, 3, 10, 30, and 100 mW	Keysight 11683A	1	P
20 dB Attenuator	DC to 50 GHz 2.4 mm (m) to 2.4 mm (f)	Keysight 8490D (Opt. 020)	1	P, T
Power Splitter	DC to 50 GHz 2.4 mm (f3x)	Keysight 11667C/D	1	P, T

Table 1-1 Recommended Test Equipment and Accessories (continued)

Instrument Type	Required Characteristics	Model Recommended ^[a]	Quantity Required	Use ^[b]
Cables	BNC (m) to BNC (m) 2.4 mm (m) to 2.4 mm (m)	Keysight 10503 series	2	OV, P, C, T
Adapters	BNC (f) to Type N (m)	Keysight E9635A	1	P, C, T
	BNC (m) to SMA (f)	Keysight 1250-2015	1	
	3.5 mm (f) to 2.92 mm (m)	–	1	
	2.92 mm (m) to 2.4 mm (m)	Keysight 11904A	1	
	2.92 mm (m) to 2.4 mm (f)	Keysight 11904D	1	
	2.4 mm (m) to 2.4 mm (m)	Keysight 11900A	1	
	2.4 mm (f) to 2.4 mm (f)	Keysight 11900B	1	

[a] Equivalent equipment can be substituted for all instruments and accessories.

[b] OV = Operational Verification P = Performance Tests C = Calibration T = Troubleshooting

[c] One supplied with Keysight 53147A/48A/49A

Operational Verification

Operational Verification is an abbreviated series of tests that you can perform (instead of performing the Complete Performance Tests) to provide a high degree of confidence that the instrument is operating properly. Operational Verification is useful for incoming inspection, routine maintenance, and after instrument repair.

If you are not familiar with operating the instrument, you should review the Chapter 1, “Getting Started,” in the *Keysight 53147A/148A/149A Operating Guide*. However, the procedures in this chapter are written so that little experience is necessary. These procedures should be followed in the order in which they appear.

Power-On Self Tests

NOTE

This test is appropriate for the Keysight 53147A, 53148A, and 53149A.

- 1 Inspect the instrument for damage.
- 2 Make sure no cables are connected to the instrument’s inputs.
- 3 Connect the power cord to the instrument and the power source.

NOTE

- Since the instrument’s power supply automatically senses the line voltage, there is no AC input-voltage setting.
 - It is normal for the fan in the instrument to run when the instrument is in Standby mode. Power is supplied to the timebase whenever the power cord is connected to maintain long-term measurement reliability, and the fan helps to maintain the timebase’s temperature stability.
-

- 4 Press and release the **Power** button on the front panel.

- 5 Verify that the front-panel display shows the following:
 - All segments of the front-panel display are temporarily activated.
 - **TESTING** is displayed.
 - **SELF TEST OK** is displayed.
 - The model number of the instrument is displayed (a four-digit hex number is also displayed).
 - **GPIB ADDR nn** (nn = a two digit number from 0 to 30) is displayed.
 - **CH2 NO SIGNAL** is displayed.
- 6 If an error message is displayed, refer to the troubleshooting section in Chapter 2, “**Service**”
- 7 Mark Pass or Fail in the “**Performance Test Record**” on page 51, “**Test 1**”.

NOTE

To ensure that the test results are valid, the instrument and the test equipment should be powered on for at least 30 minutes prior to beginning the tests. This allows the internal temperatures of the equipment and the timebase to stabilize.

10 MHz Test

- 1 Connect a BNC-to-BNC cable from the **Reference 10MHz** connector on the instrument’s rear panel to the **CHANNEL 1** input connector on the front panel.
- 2 Press and release the **Chan Select** key.
- 3 Verify that **Ch 1** is displayed in the upper-left corner of the display.
- 4 Verify that the display reads **10,000,000 Hz**.
- 5 Mark Pass or Fail in the “**Performance Test Record**” on page 51, “**Test 2**”.

Run Self Test

NOTE

This test is appropriate for the Keysight 53147A, 53148A, and 53149A.

- 1 Disconnect all signal cables from the input and **Reference 10MHz** connectors.
- 2 Press and release the **Shift** key, and then press and release the **Menu (Reset/Local)** key.
- 3 Press the up- and/or down-arrow key(s) as many times as necessary until **DO SELF TEST** is displayed.
- 4 Press and release the **Enter** key.
- 5 If no errors are detected, **SELF TEST OK** is briefly displayed when the self test is completed. If any error messages are displayed, refer to the troubleshooting section in Chapter 2, “**Service**”.
- 6 Mark Pass or Fail in the “**Performance Test Record**” on page 51, “**Test 3**”.

External Timebase Test

This test verifies the instrument’s 10 MHz external timebase specification by verifying that setting **REF OSC** to **EXT** allows the instrument to be synchronized to an external reference signal.

Equipment Required

Keysight 3325A/B Synthesizer (2)
Keysight 10100C 50 Ω Feedthrough Terminator
Keysight 10503 Series Coaxial Cables (BNC m to m) (2)

NOTE

- To ensure that the test results are valid, the instrument and the test equipment should be powered on for at least 30 minutes prior to beginning the tests. This allows the internal temperatures of the equipment to stabilize.
 - These tests are appropriate for the Keysight 53147A, 53148A, and 53149A.
-

- 1 Connect an Keysight 10503 series coaxial cable between the output of the first Keysight 3325A/B Synthesizer and the **Reference 10MHz** connector on the instrument's rear panel (see [Figure 1-1](#)).
- 2 Connect an Keysight 10100C 50 Ω Feedthrough Terminator to the Counter's **Channel 1** input connector.
- 3 Connect an Keysight 10503 series coaxial cable between the output of the second Synthesizer and the feedthrough terminator on the Counter's **CHANNEL 1** input connector.

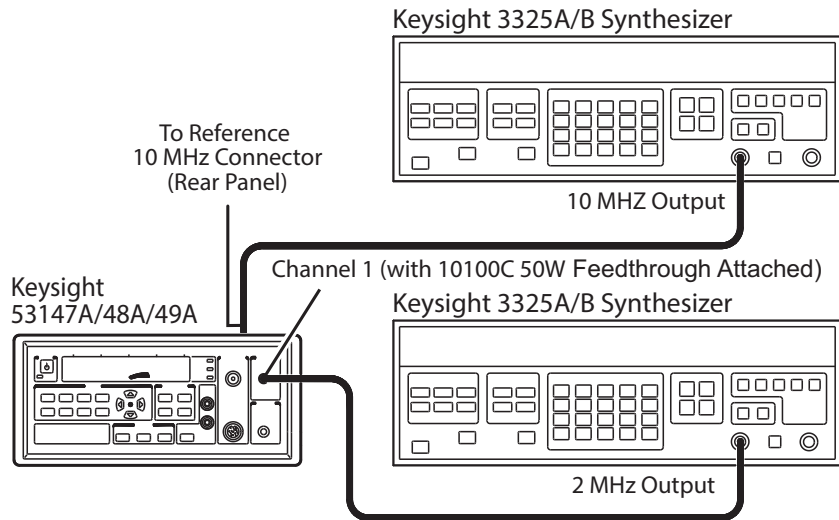

Figure 1-1 External Timebase Test Setup

- 4 Cycle the **POWER** button to preset the instrument.
- 5 Press the **Shift** key on the instrument's front panel.
- 6 Press the **Menu** key on the instrument's front panel.
- 7 If necessary, use the up- and down-arrow keys to cycle the display until it reads **REF OSC > INT**.
- 8 Press the right-arrow key once. **INT** begins to flash off and on.
- 9 Press the up- or down-arrow key once. **INT** changes to **EXT**.
- 10 Press the **Enter** key.
- 11 Press the **Chan Select** key once to select the **CHANNEL 1** input connector.

1 Performance Tests - Verifying Specifications

- 12 Set the frequency of the first Synthesizer (connected to the instrument's rear-panel **Reference 10MHz** connector) to 10 MHz at 1 V rms.
- 13 Set the frequency of the second Synthesizer (connected to the instrument's **Channel 1** input connector) to 2 MHz at 100 mV rms.
- 14 Press and release the instrument's **Reset/Local** key.
- 15 Verify that the Counter displays a reading of approximately 2 MHz and that the **Ext Ref** annunciator is activated.
- 16 Mark Pass or Fail for "Test 4" in the "Performance Test Record" on page 51.
- 17 Disconnect the test setup.

Power Meter Test

This test verifies the accuracy of the Power Meter.

Equipment Required

Keysight 11730A Power Sensor Cable (supplied with instrument)
Keysight 8481A, 8481D, 8482A, 8485A, or 8487A Power Sensor Head

NOTE

- To ensure that the test results are valid, the instrument and the test equipment should be powered on for at least 30 minutes prior to beginning the tests. This allows the internal temperatures of the equipment to stabilize.
- These tests are appropriate for the Keysight 53147A, 53148A, and 53149A.

-
- 1 Connect one end of the Keysight 11730A cable (supplied with instrument) to the Power Meter **INPUT** connector on the front panel of the Keysight 53147A, 53148A, or 53149A.
 - 2 Connect the other end of the Keysight 11730A cable to a power sensor head.

- 3 Press the **Display Power** key in the Power Meter area of the front panel.
The display should look like this (the reading will vary):

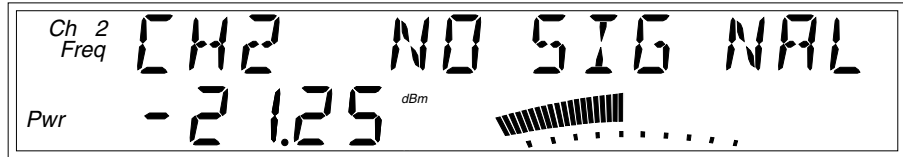

- 4 If the power sensor head you are using is an Keysight 8481A, 8481D, 8482A, 8485A, or 8487A, select the power sensor head model in the **HEAD** menu. If you are not using one of the power sensor heads listed above, press the **Cal Factor** key, and enter the calibration factor for the head.
- 5 Press the **Zero** key.
The display shows **ZEROING** for several seconds.
- 6 Connect the power sensor head to the Power Meter **OUTPUT** connector.
- 7 Press the **Cal** key.
The display briefly shows **CALIBRATING**.
- 8 Turn on the power reference output in the instrument's menu (**PWR REF > ON**).
- 9 Verify that the Counter displays a reading of 0 dBm \pm .02 dB.
- 10 Mark Pass or Fail for "Test 5" in the "Performance Test Record" on page 51.
- 11 Disconnect the test setup.

DVM Test

This test verifies the accuracy of the DVM.

Equipment Required

Keysight 34401A Digital Multimeter
Keysight E3640A DC Power Supply

NOTE

- To ensure that the test results are valid, the instrument and the test equipment should be powered on for at least 30 minutes prior to beginning the tests. This allows the internal temperatures of the equipment to stabilize.
- These tests are appropriate for the Keysight 53147A, 53148A, and 53149A.

- 1 Set the output of the E3640A DC Power Supply to +25 VDC.
- 2 Set the Keysight 34401A Digital Multimeter to the lowest DC voltage range capable of safely measuring 25 VDC.
- 3 Connect the test leads to the Multimeter (observe correct polarity).
- 4 Connect the test prods to the output terminals on the Keysight E3640A DC Power Supply (observe correct polarity).

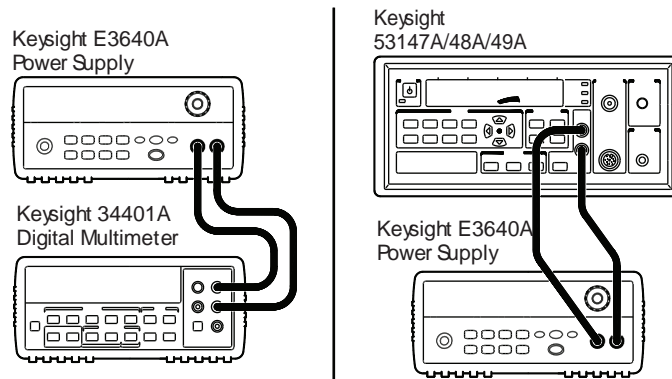

Figure 1-2 DVM Test Setup

- 5 Observe and record the voltage reading on the Keysight 34401A Multimeter.

- 6 Disconnect the test leads from the Keysight E3640A DC Power Supply. Be careful not to disturb the voltage setting.
- 7 Connect the test leads to the Keysight 53147A/48A/49A (be sure to observe the correct polarity).
- 8 Press the **Display DVM** key on the Keysight 53147A/48A/49A front panel.
- 9 Connect the test prods to the output terminals on the Keysight E3640A DC Power Supply (be sure to observe the correct polarity).
- 10 Observe and record the voltage reading on the Keysight 53147A/48A/49A.
- 11 Compare the voltage readings you recorded in steps 5 and 10. If the reading taken with the Keysight 53147A/48A/49A is within $\pm 0.25\% \pm 10$ mV of the reading taken with the Keysight 34401A, mark Pass for "Test 6" in the "Performance Test Record" on page 51. If the reading taken with the Keysight 53147A/48A/49A is not within $\pm 0.25\% \pm 10$ mV of the reading taken with the Keysight 34401A, mark Fail for "Test 6" in the "Performance Test Record" on page 51.

This completes the Operational Verification.

Complete Performance Tests

The Complete Performance Tests verify the specifications of the Keysight 53147A/148A/149A listed in Chapter 6, “Specifications”. All of these tests can be performed without opening the instrument. Table 1-3 lists a summary of the performance tests.

Record the results of the performance tests in the appropriate place on the Performance Test Record, which starts on page 51.

NOTE

To ensure that the test results are valid, the instrument and the test equipment should be powered on for at least 30 minutes prior to beginning the tests. This allows the internal temperatures of the equipment and the timebase to stabilize.

Table 1-2 Complete Performance Tests

Page Number	Test Description
Page 31	“Test 1: Channel 1 Frequency Sensitivity”
Page 35	“Test 2: Channel 2 Frequency Sensitivity”
Page 39	“Test 3: Power Measurement”
Page 42	“Test 4: Power Reference Oscillator Frequency”
Page 44	“Test 5: Power Meter Reference Level”

NOTE

Other instrument measurement functions (e.g., Averaging) are mathematically derived by the microprocessor from the parameters verified by these performance tests. If the instrument passes the performance tests, the other measurement functions are also functioning to specifications.

Test 1: Channel 1 Frequency Sensitivity

This set of tests verifies the frequency-sensitivity specifications of Channel 1 of the Keysight 53147A/148A/149A's Frequency Counter.

Equipment Required

Keysight 3325A/B Synthesizer
 Keysight 83650B Synthesizer
 Keysight 437B Power Meter
 Keysight 8487A/D Power Sensor
 Keysight 11730A Power Sensor Cable (provided with 53147A/148A/149A)
 Keysight 11667C Power Splitter
 Keysight 8490D (Opt. 020) 20 dB Attenuator
 Keysight 1250-2015 BNC (m) to SMA (f) Adapter
 Keysight 11904A 2.92 mm (m) to 2.4 mm (m) Adapter
 Keysight 10100C 50 Ω Feedthrough Terminator
 Keysight 10503 Series Coaxial Cable (BNC m to m)
 2 mm (m) to 2 mm (f) Cable (2)

Test 1a: 10 Hz to 20 MHz Frequency Sensitivity

NOTE

- To ensure that the test results are valid, the instrument and the test equipment should be powered on for at least 30 minutes prior to beginning the tests. This allows the internal temperatures of the equipment to stabilize.
- These tests are appropriate for the Keysight 53147A, 53148A, and 53149A.
- If the Keysight 3325A/B Synthesizer or the Keysight 83650B Synthesizer reference output is not adequate to drive the 53147A/48A/49A, connect the cable from the Synthesizer to the **Reference 10 MHz** connector on the back of the 53147A/48A/49A, and set the 53147A/48A/49A to use the internal oscillator.

-
- 1 Connect an Keysight 10503 Series Coaxial Cable between the reference output connector on the Keysight 3325A/B Synthesizer and the instrument's **Reference 10MHz** connector.
 - 2 Connect an Keysight 10100C 50 Ω Feedthrough Terminator to the Counter's **CHANNEL 1** connector.

- 3 Connect an Keysight 10503 Series Coaxial Cable between the RF output connector on the Keysight 3325A/B Synthesizer and the 50 Ω feedthrough terminator on the Counter's **CHANNEL 1** connector.

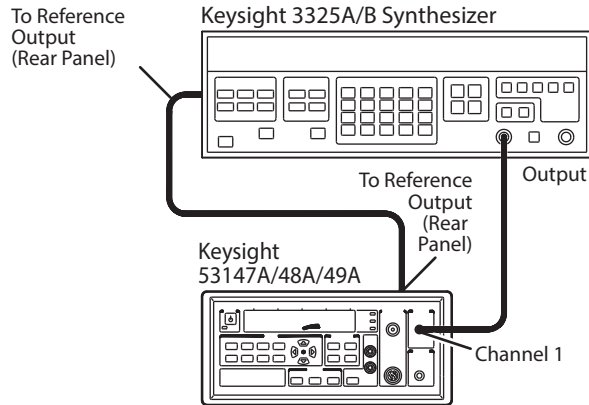

Figure 1-3 10 Hz to 20 MHz Frequency Sensitivity Test Setup

- 4 Verify that the Counter is still set to use an external reference signal (refer to steps 5 through 10 on page 25).
- 5 Set the output of the Synthesizer to the first frequency specified for “Test 1a” in the “Performance Test Record” on page 51 (10 Hz).
- 6 Set the power output of the Synthesizer to the first power value specified for “Test 1a” in the “Performance Test Record” on page 51 (–14.9 dBm/40 mV).
- 7 Record the frequency value read on the Counter (± 1 count) for “Test 1a” in the “Performance Test Record” on page 51.
- 8 Repeat steps 5, 6, and 7 for each of the remaining frequencies specified for “Test 1a”. Don’t forget to change the power level when performing the 1 KHz test (–19.2 dBm/25 mV).
- 9 If all of the frequency values you recorded for “Test 1a” are correct, mark Pass in the Performance Test Record for “Test 1a”. If any of the frequency readings you recorded are incorrect, mark Fail in the Performance Test Record.

NOTE

- Do not disconnect the cable from the instrument's **Reference 10MHz** connector. This connection is used in the following test.
- Do not turn off the instrument. Turning the instrument off and back on resets the reference oscillator (REF OSC) selection to internal (INT) and the channel selection to **CHANNEL 2**.

Test 1b: 50 MHz to 125 MHz Frequency Sensitivity

- 1 Connect an Keysight 10100C 50 Ω Feedthrough Terminator to the **CHANNEL 1** input connector on the instrument's front panel (refer to Figure 1-4 for steps 1 through 9).

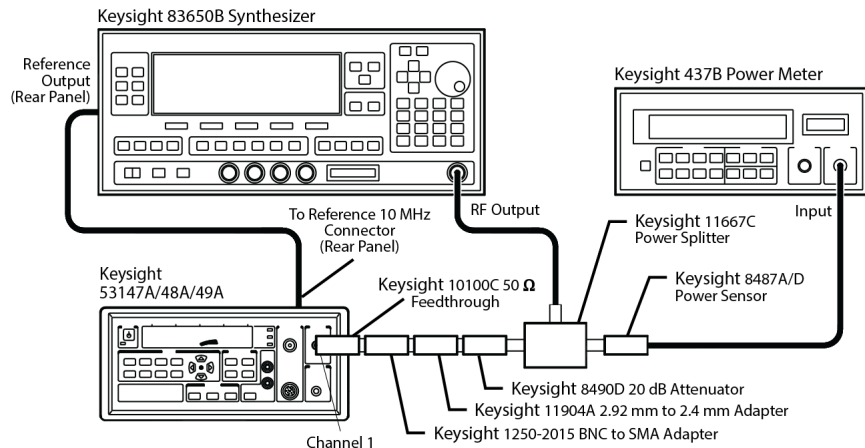

Figure 1-4 50 MHz to 125 MHz Frequency Sensitivity Test Setup

- 2 Connect the Keysight 1250-2015 BNC (m) to SMA (f) Adapter to the Keysight 10100C Feedthrough Terminator on the Counter's **CHANNEL 1** connector.
- 3 Connect the Keysight 11904A 2.92 mm (m) to 2.4 mm (m) Adapter to the Keysight 1250-2015 Adapter.
- 4 Connect the Keysight 8490D 20 dB Attenuator to the Keysight 11904A Adapter.

- 5 Connect one of the output connectors on the Keysight 11667C Power Splitter to the Keysight 8490D Attenuator
- 6 Connect the Keysight 11900B 2.4 mm (f) to 2.4 mm (f) Adapter to the RF output of the Synthesizer.
- 7 Connect a 2.4 mm (m) to 2.4 mm (m) cable between the Adapter on the Synthesizer's RF output connector and the input connector on the Keysight 11667C Power Splitter.
- 8 Connect the Keysight 8487A/D Power Sensor to the remaining output connector on the Keysight 11667C Power Splitter.
- 9 Connect the Keysight 11730A Power Sensor Cable between the Power Sensor and the sensor connector on the Keysight 437B Power Meter.
- 10 Verify that the Counter is still set to use an external reference signal (refer to steps 5 through 10 on page 25).
- 11 Set the output of the Keysight 83650B Synthesizer to the first frequency specified for "Test 1b" in the "Performance Test Record" on page 51 (50 MHz).
- 12 Set the power output of the Synthesizer (read on the Power Meter) to a power value 20 dBm above the value specified for "Test 1b" in the "Performance Test Record" on page 51 (+.8 dBm). (The added 20 dBm compensates for the 20 dB Attenuator.)
- 13 Record the frequency value read on the Counter (± 1 count) for "Test 1b" in the "Performance Test Record" on page 51.
- 14 Set the output of the Synthesizer to 125 MHz, and repeat steps 11 through 13.
- 15 If both of the frequency values you recorded for "Test 1b" are correct, mark Pass in the Performance Test Record for "Test 1b". If either of the frequency readings you recorded are incorrect, mark Fail in the Performance Test Record.
- 16 Disconnect the Keysight 10100C Feedthrough Terminator, the Keysight 1250-2015 Adapter, and the Keysight 11904A Adapter from the Counter's **CHANNEL 1** connector.

NOTE

- Do not disconnect the rest of the test setup, as these connections are also used in the Channel 2 Frequency Sensitivity test.
- Do not turn off the instrument. Turning the instrument off and back on resets the reference oscillator (REF OSC) selection to internal (INT).

Test 2: Channel 2 Frequency Sensitivity

This set of tests verifies the frequency-sensitivity specifications of Channel 2 of the Keysight 53147A/148A/149A's Frequency Counter.

Equipment Required

Keysight 83650B Synthesizer
 Keysight 437B Power Meter
 Keysight 8487A/D Power Sensor
 Keysight 11667C Power Splitter
 Keysight 11730A Power Sensor Cable (provided with 53147A/148A/149A)
 Keysight 8490D (Opt. 020) 20 dB Attenuator
 Keysight 11904D 2.92 mm (m) to 2.4 mm (f) Adapter
 Keysight 10503 series Coaxial Cable (BNC m to m)
 2.4 mm (m) to 2.4 mm (m) Cable (2)

Test 2a: 50 MHz to 20 GHz Frequency Sensitivity

NOTE

- To ensure that the test results are valid, the instrument and the test equipment should be powered on for at least 30 minutes prior to beginning the tests. This allows the internal temperatures of the equipment to stabilize.
- This test is appropriate for the Keysight 53147A, 53148A, and 53149A.

- 1 Connect the Keysight 11904D 2.92 mm (m) to 2.4 mm (f) Adapter to the Counter's **CHANNEL 2** input connector (refer to [Figure 1-5](#) for steps 1 through 4).
- 2 Connect the Keysight 8490D Attenuator to the Keysight 11904D Adapter, as shown in [Figure 1-5](#) (the other end of the Attenuator should remain connected to the Keysight 11667C Power Splitter).
- 3 Verify that the cable (with Adapter) is still connected between the RF output of the Keysight 83650B Synthesizer and the Power Splitter input connector.

- 4 Verify that the Power Sensor is still connected to the Power Splitter and that the Power Sensor Cable is still connected between the Power Sensor and the sensor connector on the Power Meter.

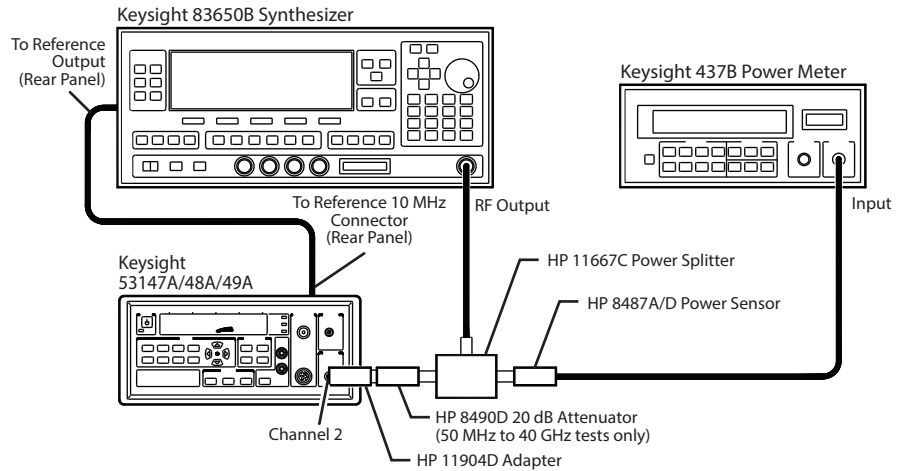

Figure 1-5 50 MHz to 20 GHz Frequency Sensitivity Test Setup

- 5 Verify that the instrument is still set to use an external reference signal (refer to steps 5 through 10 on page 25).
- 6 Set the output of the Keysight 83650B Synthesizer to the first frequency specified for “Test 2a” in the “Performance Test Record” on page 52 (50 MHz).
- 7 Set the power output of the Synthesizer (read on the Power Meter) to a power value 20 dBm above the value specified for “Test 2a” in the “Performance Test Record” on page 52 (0 dBm). (The added 20 dBm compensates for the 20 dB Attenuator.)
- 8 Record the frequency value read on the Counter (± 1 count) for “Test 2a” in the “Performance Test Record” on page 52.
- 9 Repeat steps 6, through 8 for each of the remaining frequencies specified for “Test 2a”. Don’t forget to change the power level when performing the 300 MHz and 19 GHz tests (53147A, 53148A, and 53149A) and the 16 GHz and 19 GHz tests (53149A only).

NOTE

It may be necessary to repeat Step 5.

- 10 If all of the frequency values you recorded for “Test 2a” are correct, mark Pass in the Performance Test Record. If any of the frequency readings you recorded are incorrect, mark Fail in the Performance Test Record.

Test 2b: 22 GHz to 26.5 GHz Frequency Sensitivity

NOTE

This test is appropriate for the Keysight 53148A and 53149A.

- 1 Use the same test setup as described for “Test 2a” on page 35.
- 2 Set the output of the Keysight 83650B Synthesizer to the first frequency specified for “Test 2b” in the “Performance Test Record” on page 52 (22 GHz).
- 3 Set the power output of the Synthesizer (read on the Power Meter) to a power value 20 dBm above the value specified for “Test 2b” in the “Performance Test Record” on page 52 (-5 dBm for the Keysight 53148A; -7 dBm for the Keysight 53149A). (The added 20 dBm compensates for the 20 dB Attenuator.)
- 4 Record the frequency value read on the Counter (± 1 count) for “Test 2b” in the “Performance Test Record” on page 52.
- 5 Repeat steps 2, through 4 for each of the remaining frequencies specified for “Test 2b”.
- 6 If all of the frequency values you recorded for “Test 2b” are correct, mark Pass in the Performance Test Record for “Test 2b”. If any of the frequency readings you recorded are incorrect, mark Fail in the Performance Test Record.

Test 2c: 30 GHz to 46 GHz Frequency Sensitivity

NOTE

This test is appropriate for the 53149A only.

- 1 Use the same test setup as described for “Test 2a” on page 35.
- 2 Set the output of the Keysight 83650B Synthesizer to the first frequency specified for “Test 2c” in the “Performance Test Record” on page 52 (30 GHz).
- 3 Set the power output of the Synthesizer (read on the Power Meter) to a power value 20 dBm above the value specified for “Test 2c” in the “Performance Test Record” on page 52 (-3 dBm). (The added 20 dBm compensates for the 20 dB Attenuator.)
- 4 Record the frequency value read on the Counter (± 1 count) for “Test 2c” in the “Performance Test Record” on page 52.
- 5 Repeat steps 2, through 4 for each of the remaining frequencies specified for “Test 2c”. Don’t forget to change the power level for the 42, 44, and 46 GHz tests.
- 6 If all of the frequency values you recorded for “Test 2c” are correct, mark Pass in the Performance Test Record for “Test 2c”. If any of the frequency readings you recorded are incorrect, mark Fail in the Performance Test Record.

NOTE

- Do not disconnect the Power Sensor or the Power Sensor Cable from the power meter or the Power Splitter. These connections are reused in the following tests.
 - Do not turn off the instrument. Turning the instrument off and back on resets the reference oscillator (REF OSC) selection to internal (INT).
-

Test 3: Power Measurement

This set of tests verifies the power-measurement specifications of Keysight 53147A/148A/149A's Power Meter.

Equipment Required

Keysight 11683A Range Calibrator

Keysight 11730A Power Sensor Cable (provided with 53147A/148A/149A)

Power Measurement Accuracy Test

NOTE

- To ensure that the test results are valid, the instrument and the test equipment should be powered on for at least 30 minutes prior to beginning the tests. This allows the internal temperatures of the equipment to stabilize.
- These tests are appropriate for the Keysight 53147A, 53148A, and 53149A.

- 1 Connect the Keysight 11730A Power Sensor Cable between Keysight 11683A Range Calibrator's output connector and the Keysight 53147A, 53148A, or 53149A's Power Meter **INPUT** connector.

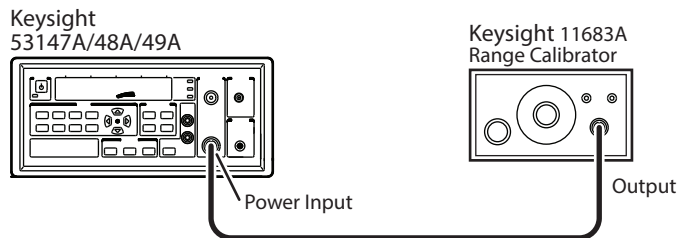

Figure 1-6 Power Measurement Accuracy Test Setup

- 2 Press the **Reset/Local** key on the Keysight 53147A, 53148A, or 53149A.
- 3 Press the **Shift + dBm/W** key on the Keysight 53147A, 53148A, or 53149A to set the Power Meter to display readings in Watts, mW, and/or μ W.

- 4 Set the Range Calibrator switches as follows:

FUNCTION: STANDBY
POLARITY: NORMAL
RANGE: 1 mW
LINE: ON

- 5 Press the **Zero** key on the Keysight 53147A, 53148A, or 53149A. When the reading appears, verify that it is $0.00 \pm 0.06 \mu\text{W}$.
- 6 Change the Range Calibrator's **FUNCTION** switch to **CALIBRATE**.
- 7 Press the **Cal** key on the Keysight 53147A, 53148A, or 53149A. Wait for the Power Meter to complete calibration.
- 8 Verify that the Keysight 53147A, 53148A, or 53149A display reads $1.000 \pm 0.006 \text{ mW}$.

NOTE

The Range Calibrator output level is adjustable in 5 dB increments. Thus, the 3 μW , 30 μW , 300 μW , 3 mW, and 30 mW legends on the **RANGE** switch are approximations. The true values for these settings are 3.16 μW , 31.6 μW , 316 μW , 3.16 mW, and 31.6 mW.

- 9 Set the Range Calibrator **RANGE** switch to each of the positions shown in [Table 1-3](#). For each setting, verify that the Keysight 53147A, 53148A, or 53149A autoranges properly and that the reading displayed is within the limits shown in the table.

NOTE

- The lower the setting of the **RANGE** switch, the longer it takes for the reading to stabilize.
 - You may have to repeat Step 5 (re-zero the instrument) for each measurement.
-

Table 1-3 Range Calibrator Settings and Expected Results

Range Calibrator	Keysight 53147A/48A/49A		
RANGE Switch Setting	Minimum	Actual	Maximum
3 μ W	3.10 μ W		3.23 μ W
10 μ W	9.90 μ W		10.10 μ W
30 μ W	31.4 μ W		31.8 μ W
100 μ W	99.5 μ W		100.5 μ W
300 μ W	0.314 mW		0.318 mW
1 mW	0.995 mW		1.005 mW
3 mW	3.14 mW		3.18 mW
10 mW	9.95 mW		10.05 mW
30 mW	31.4 mW		31.8 mW
100 mW	99.5 mW		100.5 mW

- 10** Record the actual power readings in the “Performance Test Record” on page 51.
- 11** Press the **Shift + dBm/W** key on the Keysight 53147A, 53148A, or 53149A again to set the Power Meter to display readings in dBm.
- 12** Verify that the annunciator changes to **dBm** and that the indication is within 20.00 ± 0.04 dBm with the Range Calibrator’s **RANGE** switch in the **100 mw / 20 dBm** position.
- 13** Record the actual power reading in the Performance Test Record.
- 14** Set the Range Calibrator’s **RANGE** switch to -10 dBm.
- 15** Verify that the Power Meter displays a reading of -10.00 ± 0.04 dBm.
- 16** Record the actual power reading in the Performance Test Record.
- 17** Review all of the results for “Test 3”, and mark Pass or Fail for “Test 3” in the Performance Test Record.

Test 4: Power Reference Oscillator Frequency

The internal power reference oscillator is used to calibrate the Power Meter to the power sensor head. This test verifies that the frequency output of the power reference oscillator is 50.0 MHz \pm 0.5 MHz.

Equipment Required

Keysight 53150A Microwave Frequency Counter
Keysight 10503 Series Coaxial Cables (BNC m to m)
Keysight 1250-1535 BNC (f) to Type N (m) Adapter

Power Reference Oscillator Frequency Test

NOTE

- The instrument and the test equipment must be powered on for at least 30 minutes prior to measuring the power reference oscillator output. This allows the internal temperatures of the equipment to stabilize.
- This procedure specifies the Keysight 53150A for measuring the frequency output of the 53147A/48A/49A's power reference oscillator. If the 53147A/48A/49A's Frequency Counter is known to be in calibration (see **“Test 1: Channel 1 Frequency Sensitivity”** on page 31), you can use it in place of the 53150A in this procedure.

-
- 1 Connect an Keysight E9635A adapter to the Keysight 53147A/48A/49A's Power Meter **OUTPUT** connector as shown in **Figure 1-7**.

- 2 Connect an Keysight 10503 series cable between the Keysight E9635A adapter on the Keysight 53147A/148A/149A's Power Meter **OUTPUT** connector and the **CHANNEL 1** input connector on the Keysight 53150A/51A/52A Frequency Counter.

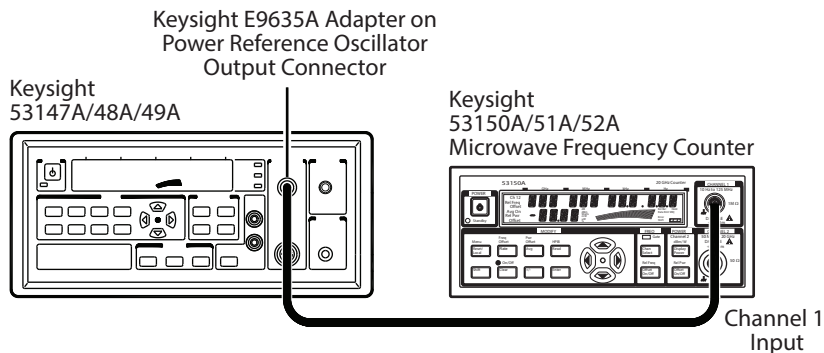

Figure 1-7 Reference Oscillator Frequency Adjustment Setup

- 3 Set the Keysight 53150A/51A/52A Frequency Counter to measure frequency on Channel 1.
- 4 Turn on the Keysight 53147A/48A/49A's internal power reference oscillator:
Press **Shift + Menu**, use the up and/or down arrow keys to cycle through the menu to **PWR REF**, press the right-arrow key, then use the up or down arrow key to change the setting to **ON**, and press the **Enter** key. The **Pwr Ref** annunciator should now be activated.

NOTE

The reference oscillator is normally off. It is turned on automatically during calibration and then turned back off when calibration is complete. Setting PWR REF in the 53147A/148A/149A's menu to ON turns the power reference oscillator on, and it remains on until the PWR REF menu setting is returned to OFF. When you calibrate the Power Meter with PWR REF set to ON, the power reference oscillator remains on after calibration is complete.

- 5 Record the power reading shown on the Keysight 53150A/51A/52A for "Test 4" in the "Performance Test Record" on page 51.
- 6 Mark Pass or Fail for "Test 4" in the Performance Test Record.

Test 5: Power Meter Reference Level

Two methods for verifying the level of the Power Meter reference signal are provided in this section. Both methods provide acceptable results, and either one can be used.

Power Meter Reference Level: Method 1

Equipment Required

Keysight E4418B Power Meter

Keysight 8481A Power Sensor

Keysight 11730A Power Sensor Cable (supplied with 53147A/48A/49A)

NOTE

- To ensure that the test results are valid, the Keysight 53147A/48A/49A and the test equipment should be powered on for at least 30 minutes prior to beginning the tests. This allows the internal temperatures of the equipment to stabilize.
- The calibration of the Keysight E4418B Power Meter must be no more than one level removed from NIST (National Institute of Standards and Technology). If the E4418B Power Meter's calibration is more than one level removed from NIST, the test results will be invalid.
- This test is appropriate for the Keysight 53147A, 53148A, and 53149A.

-
- 1 Connect the Keysight 11730A Power Sensor Cable to the Keysight 8481A Power Sensor (see [Figure 1-8](#)).

Figure 1-8 E4418B Power Meter Zeroing and Calibration Test Setup

- 2 Connect the free end of the Keysight 11730A Power Sensor Cable to the input connector on the Keysight E4418B Power Meter.
- 3 Connect the Keysight 8481A Power Sensor to the power reference output connector of the Keysight E4418B Power Meter.
- 4 Zero the E4418B Power Meter.
- 5 Calibrate the E4418B Power Meter.
- 6 Disconnect the Keysight 8481A Power Sensor from the Keysight E4418B Power Meter, and immediately connect it to the Power **OUTPUT** connector on the Keysight 53147A/48A/49A (see [Figure 1-9](#)).

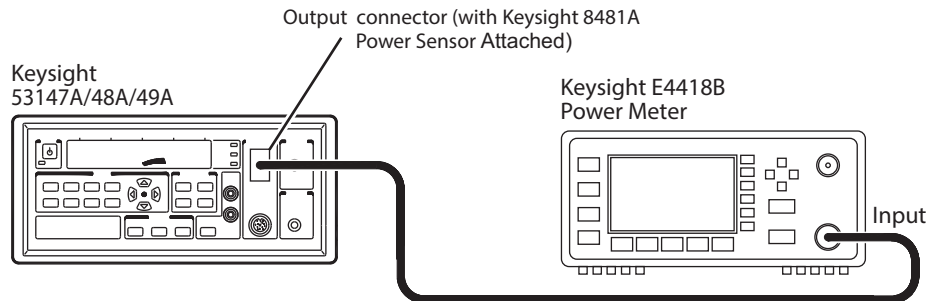

Figure 1-9 Power Meter Reference Level Test Setup

- 7 Record the power reading shown on the Keysight E4418B Power Meter for "Test 5" in the "Performance Test Record" on page 51.
- 8 Mark Pass or Fail for "Test 5" in the Performance Test Record.

Power Meter Reference Level: Method 2

Equipment Required

Keysight 432A Power Meter
Keysight 478A-H75 or 478A-H76 Thermistor Mount
Keysight 34401A Digital Multimeter
Keysight 8120-1082 Power Sensor Cable

NOTE

- To ensure that the test results are valid, the instrument and the test equipment should be powered on for at least 30 minutes prior to beginning the tests. This allows the internal temperatures of the equipment to stabilize.
- This test is appropriate for the Keysight 53147A, 53148A, and 53149A.

- 1 Turn the Keysight 432A Power Meter off. Do not turn it on until instructed to do so.
- 2 Set the Keysight 34401A Digital Multimeter to measure resistance, and connect the DVM test prods between the center pin of the V_{RF} connector on the Keysight 432A Power Meter rear panel and pin 1 on the thermistor-mount end of the Keysight 8120-1082 Power Sensor Cable (see [Figure 1-10](#) to locate pin 1).

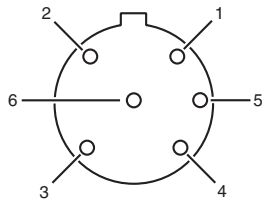

Figure 1-10 Keysight 8120-1082 Power Sensor Cable End View

- 3 Round off the resistance reading to two decimal places and keep a record of this value as R. It is the internal bridge resistance (R) of the Keysight 432A Power Meter (this should be approximately 200.3 ohms).
- 4 Connect the Keysight 478A-H75 or 478A-H76 Thermistor Mount to the Keysight 53147A/148A/149A Power Meter **OUTPUT** connector, as shown in [Figure 1-11](#).

NOTE

Do not use a cable between the Thermistor Mount and the 53147A/148A/149A Power Meter OUTPUT connector. Connect the Thermistor Mount directly to the OUTPUT connector.

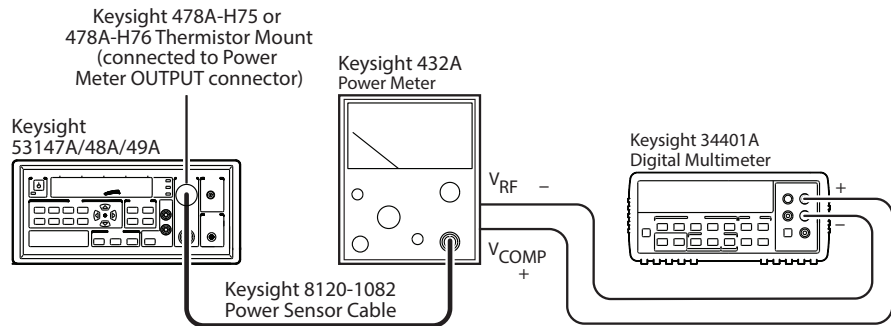

Figure 1-11 Power Meter Reference Level Test Setup

- 5 Connect the Keysight 8120-1082 Power Sensor Cable between the Thermistor Mount and the input connector on the Keysight 432A Power Meter.
- 6 Turn on the 432A Power Meter. Wait 30 minutes for the Power Meter and the Thermistor Mount to stabilize before proceeding to the next step.
- 7 Set the 432A Power Meter's **RANGE** switch to **Coarse Zero**.
- 8 Adjust the **COARSE ZERO** control on the 432A Power Meter's front panel to obtain a zero reading on the meter.
- 9 Set the 432A Power Meter's **RANGE** switch to **.01 mW / -20 dBm**.
- 10 Press the **FINE ZERO** switch on the 432A Power Meter's front panel down to obtain a zero reading on the meter.
- 11 Set the 432A Power Meter's **RANGE** switch to **1 mW**.
- 12 Set the Digital Multimeter to measure microvolts.

CAUTION

Ensure that the Keysight 34401A Digital Multimeter's input leads are isolated from chassis ground before performing the next step.

- 13 Connect the positive test prod from the Keysight 34401A Multimeter to the V_{COMP} connector on the Keysight 432A Power Meter rear panel.

NOTE

The V_{COMP} and V_{RF} connectors are BNC female. You can use two BNC-to-banana jack adapters and two BNC cables to make it easier to connect the Multimeter to the Power Meter.

- 14 Connect the negative test prod from the Keysight 34401A Digital Multimeter to the V_{RF} connector on the 432A Power Meter's rear panel.
- 15 If the reading on the Multimeter is less than 400 microvolts, proceed to step 16. If the reading is 400 microvolts or more, press the **FINE ZERO** toggle switch on the 432A Power Meter's front panel down.
- 16 Observe the reading on the Multimeter, round off the reading to the nearest microvolt, and keep a record of this value as V_0 .
- 17 Turn on the Keysight 53147A/148A/149A's internal power reference oscillator:
Press **Shift + Menu**, use the up and/or down arrow keys to cycle through the menu to **PWR REF**, press the right-arrow key, then use the up or down arrow key to change the setting to **ON**, and press the **Enter** key. The **Pwr Ref** annunciator should now be activated.

NOTE

The reference oscillator is normally off. It is turned on automatically during calibration and then turned back off when calibration is complete. When **PWR REF** in the 53147A/148A/149A's menu is set to **ON**, the power reference oscillator is turned on, and it is left on after calibration.

- 18 Observe the reading on the Multimeter, and keep a record of this value as V_1 .
- 19 Disconnect the Multimeter's negative test lead from the 432A Power Meter's V_{RF} connector, and connect it to the 432A Power Meter's chassis ground.
- 20 Observe the reading on the Multimeter, and keep a record of this value as V_{COMP} .
- 21 Calculate the output level of the 53147A/148A/149A's power reference oscillator (P_{rf}) using the following formula:

$$P_{rf} = \frac{2 V_{comp} (V_1 - V_0) + V_0^2 - V_1^2}{4R \text{ (Calibration Factor)}}$$

Where:

- P_{rf} = Power reference oscillator output level
- V_{comp} = previously recorded value
- V_1 = previously recorded value
- V_0 = previously recorded value
- R = previously recorded value
- Calibration Factor = value for thermistor mount at 50 MHz (traceable to NIST)

NOTE

The following is an example showing how a calculation of the Power Reference Output Level is performed:

$$R = 200 \Omega$$

$$V_0 = 170 \mu V \text{ or } 170 \times 10^{-6} V$$

$$V_1 = 78,107 \mu V \text{ or } 78,107 \times 10^{-6} \text{ or } .078 V$$

$$V_{comp} = 5.1583 V$$

$$R = \text{previously recorded value}$$

$$\text{Calibration Factor} = 99.68\%$$

$$P_{rf} = \frac{2 V_{comp} (V_1 - V_0) + V_0^2 - V_1^2}{4R (\text{Calibration Factor})}$$

Note that V_0 is eventually dropped out of the equation in the following steps, because its value is very small (effectively zero).

$$\begin{aligned} P_{rf} &= \frac{2 (5.1583) (.078 - 0)^2 + (.000170)^2 - (0.78)}{4(200) (99.68\%)} \\ &= \frac{0.80469 - 0.00608}{797.44} = \frac{0.79861}{797.44} \\ &= 1.00147 \text{ mW} \end{aligned}$$

22 Verify that P_{rf} is between 0.988 mW and 1.012 mW.

23 Record the value for P_{rf} in the “Performance Test Record” on page 51.

24 Mark Pass or Fail for “Test 5” in the Performance Test Record.

Performance Test Record (Page 1 of 3)

Keysight 53147A/148A/149A Frequency Counter/Power Meter/DVM				
Serial Number: _____		Repair/Work Order No.: _____		
Test Performed By: _____		Temperature: _____		
Date: _____		Relative Humidity: _____		
Notes: _____				
Pre Calibration Test <input type="checkbox"/>		Post Calibration Test <input type="checkbox"/>		
Test Number	Operational Verification	Specifications	Test Results	
			Pass	Fail
1	Power on Self Tests	N/A	<input type="checkbox"/>	<input type="checkbox"/>
2	10 MHz Test	10,000,000 Hz	<input type="checkbox"/>	<input type="checkbox"/>
3	Run Self Test	N/A	<input type="checkbox"/>	<input type="checkbox"/>
4	10 MHz External Timebase Input Test	2 MHz	<input type="checkbox"/>	<input type="checkbox"/>
5	Power Meter Test	0 dBm ±.02 dB	<input type="checkbox"/>	<input type="checkbox"/>
6	DVM Test	+25 Vdc ±0.25% ±10 mV (+24.365 Vdc to +25.635 Vdc)	<input type="checkbox"/>	<input type="checkbox"/>
Test Number	Complete Performance Tests	Specifications	Test Results	
			Pass	Fail
1a	Channel 1 Frequency Sensitivity	10 Hz @ 40 mV rms (-14.9 dBm) 30 Hz @ 40 mV rms (-14.9 dBm) 1 kHz @ 25 mV rms (-19.2 dBm) 500 kHz @ 25 mV rms (-19.2 dBm) 5 MHz @ 25 mV rms (-19.2 dBm) 10 MHz @ 25 mV rms (-19.2 dBm) 20 MHz @ 25 mV rms (-19.2 dBm)	<input type="checkbox"/>	<input type="checkbox"/>
	10 Hz		_____	_____
	30 Hz		_____	_____
	1 kHz		_____	_____
	500 kHz		_____	_____
	5 MHz		_____	_____
	10 MHz		_____	_____
20 MHz	_____	_____		
1b	Channel 1 Frequency Sensitivity	50 MHz @ 25 mV rms (-19.2 dBm) 125 MHz @ 25 mV rms (-19.2 dBm)	<input type="checkbox"/>	<input type="checkbox"/>
	50 MHz		_____	_____
	125 MHz		_____	_____

Performance Test Record (Page 2 of 3)

Test Number	Complete Performance Tests	Specifications			Test Results	
		53147A	53148A	53149A	Pass	Fail
2a	Channel 2 Frequency Sensitivity	53147A	53148A	53149A	<input type="checkbox"/>	<input type="checkbox"/>
	50 MHz	-20 dBm	-20 dBm	-20 dBm	_____	_____
	100 MHz	"	"	"	_____	_____
	250 MHz	"	"	"	_____	_____
	300 MHz	-33 dBm	-33 dBm	-33 dBm	_____	_____
	500 MHz	"	"	"	_____	_____
	1 GHz	"	"	"	_____	_____
	2.5 GHz	"	"	"	_____	_____
	5 GHz	"	"	"	_____	_____
	10 GHz	"	"	"	_____	_____
	12.4 GHz	"	"	"	_____	_____
	16 GHz	"	"	-30 dBm	_____	_____
	18 GHz	"	"	"	_____	_____
	19 GHz	-29 dBm	-29 dBm	-27 dBm	_____	_____
20 GHz	"	"	"	_____	_____	
2b	Channel 2 Frequency Sensitivity	53147A	53148A	53149A	<input type="checkbox"/>	<input type="checkbox"/>
	22 GHz	N/A	-25 dBm	-27 dBm	_____	_____
	24 GHz	N/A	"	"	_____	_____
	26.5 GHz	N/A	"	"	_____	_____
2c	Channel 2 Frequency Sensitivity	53147A	53148A	53149A	<input type="checkbox"/>	<input type="checkbox"/>
	30 GHz	N/A	N/A	-23 dBm	_____	_____
	34 GHz	N/A	N/A	"	_____	_____
	40 GHz	N/A	N/A	"	_____	_____
	42 GHz	N/A	N/A	-17 dBm	_____	_____
	44 GHz	N/A	N/A	"	_____	_____
	46 GHz	N/A	N/A	"	_____	_____

Performance Test Record (Page 3 of 3)

Test Number	Complete Performance Tests	Specifications	Test Results	
			Pass	Fail
3	Power Measurement:		<input type="checkbox"/>	<input type="checkbox"/>
	3 μ W	± 0.02 dB or $\pm 0.5\%$		
	10 μ W	"		
	30 μ W	"		
	100 μ W	"		
	300 μ W	"		
	1 mW	"		
	3 mW	"		
	10 mW	"		
	30 mW	"		
	100 mW	"		
	20.00 dBm	± 0.04 dBm		
-10.00 dBm	± 0.04 dBm			
4	Power Reference Frequency:	50.0 MHz $\pm 1\%$ (49.5 MHz to 50.5 MHz)	<input type="checkbox"/>	<input type="checkbox"/>
	50.0 MHz			
5	Power Reference Level:	1.0 mW $\pm 1.2\%$ 0.988 mW to 1.012 mW	<input type="checkbox"/>	<input type="checkbox"/>
	1.0 mW (0.00 dBm)			

THIS PAGE HAS BEEN INTENTIONALLY LEFT BLANK.

Keysight 53147A/148A/149A Microwave Frequency Counter/
Power Meter/DVM
Assembly Level Service Guide

2 Service

Introduction	56
Returning the Instrument to Keysight Technologies for Service	57
Calibration Procedures	59
Pre-Troubleshooting Information	76
Troubleshooting the Instrument	81

Introduction

This chapter provides service information for your Keysight 53147A/148A/149A. It is divided into four major sections:

- **“Returning the Instrument to Keysight Technologies for Service”** (page 57). This section provides you with step-by-step instructions on how to return the instrument for service.
- **“Calibration Procedures”** (page 59). This section provides step-by-step procedures for calibrating the Keysight 53147A/148A/149A.
- **“Pre-Troubleshooting Information”** (page 76). This section provides you with pertinent information such as safety considerations, recommended test equipment, repair and after-service considerations, and assembly identification and location.
- **“Troubleshooting the Instrument”** (page 81). This section provides you with troubleshooting procedures that isolate the faulty assembly or module. Replacement and recalibration of most modules can only be performed at an authorized Keysight Technologies Service Center.

If the instrument is under warranty, return it to Keysight for service. Refer to **“Returning the Instrument to Keysight Technologies for Service”** on page 57. If you decide to troubleshoot the instrument yourself, refer to the section titled **“Troubleshooting the Instrument”** on page 81.

Returning the Instrument to Keysight Technologies for Service

Providing Repair Information

Before shipping the instrument to an Keysight Technologies office for service or repair, call the nearest Keysight Sales Office to make arrangements. Then, tag and package the Keysight 53147A/148A/149A for shipment.

NOTE

ISD (Instrument Service Division) Emergency Response or Express Calibration Service is available for Keysight customers in the USA. If downtime is critical, you can receive your repaired instrument via overnight shipment. Call 800-403-0801, and ask for *Emergency Response or Express Calibration Service*. When your instrument is repaired, it is returned via overnight shipment at no extra charge.

- 1 Write the following information on a tag:
 - Owner's name and address
 - Instrument model number
 - Complete serial number
 - Description of service required or failure indications
- 2 Attach the tag to the instrument.
- 3 Pack the instrument.

If the original packaging materials are available, use the procedure titled "Packing the Instrument in the Original Packaging Materials." If the original packaging materials are not available, you can order new packaging materials from an Keysight Sales Office. The new packaging materials are identical to those used by the factory when packaging new instruments. To use commercially available packaging materials, use the procedure titled "Packing the Instrument in Commercially Available Packaging Materials." Both procedures are on the following page.

Packing the Instrument in the Original Packaging Materials

To prevent shipping damage, it is best to repack the instrument in its original packaging. In any correspondence, refer to the instrument by the model number and the complete serial number.

- 1 Disconnect the power cord, probes, cables, or other accessories attached to the instrument.
- 2 Make sure the folded corrugated spacer (which normally contains the manuals) is in the box to ensure proper fitting.
- 3 Make sure one of the polystyrene blocks is in its proper position in the box.
- 4 Place the instrument, front panel end first, on the polystyrene block.
- 5 Place the other polystyrene block on top of the rear end of the instrument to secure it.
- 6 Do not return the manuals with the instrument. Return an accessory only when it is a part of the failure symptoms.
- 7 Seal the shipping container securely.

Packing the Instrument in Commercially Available Packaging Materials

If the original factory packaging materials are not available, use the following procedure to pack the instrument in commercially available shipping materials.

- 1 Wrap the instrument in heavy paper or plastic.
- 2 Place the instrument in a strong shipping container. Use a double-walled carton made of at least 350 lb. test material.
- 3 Protect the control panel with cardboard.
- 4 Add a layer of shock-absorbing material that is 3 to 4 inches (70 to 100 mm) thick around all sides of the instrument cushion it and to prevent it from moving within the container
- 5 Seal the shipping container securely.
- 6 Mark the shipping container **FRAGILE**.

Calibration Procedures

There are four calibration procedures that can be performed outside of an Keysight authorized service facility. The following procedures describe how to calibrate the frequency of the instrument's timebase, the frequency and output level of the power reference oscillator, and the DVM.

Equipment Required

Table 2-1 lists the test equipment and accessories needed to perform the calibration procedures in this chapter.

Table 2-1 Recommended Test Equipment and Accessories

Instrument Type	Required Characteristics	Model Recommended ^[a]	Quantity Required
Digital Multimeter	6½ digit AC/DC	Keysight 34401A	1
Power Meter	Range 1 mW	Keysight 432A	1
Power Meter	100 kHz to 110 GHz, -70 dBm to +44 dBm	Keysight E4418B	1
Frequency Counter	10 Hz to 125 MHz	Keysight 53150A/51A/52A	1
Thermistor Mount	SWR 1.05 at 50 MHz Accuracy ±0.5% at 50 MHz	Keysight 478A-H75 or 478A-H76	1
Power Sensor	10 MHz to 18 GHz, -30 dBm to +20 dBm	Keysight 8481A	1
Power Sensor Cable	5 ft.	Keysight 11730A	1 ^[b]
Range Calibrator	3, 10, 30, 100, and 300 µW 1, 3, 10, 30, and 100 mW	Keysight 11683A	1
Serial Cable	RS-232, DB-25 to RJ-45	Keysight 53150-60215	1
Precision DC Power Supply	+ 50 V / - 50 V	Keysight 6613C or 6614C	1
Cable	BNC (m) to BNC (m)	Keysight 10503 series	1
Adapter	Type N (m) to BNC (f)	Keysight E9635A	1

[a] Equivalent equipment can be substituted for all instruments and accessories.

[b] One supplied with Keysight 53147A/148A/149A

10 MHz Timebase Calibration

Equipment Required

10 MHz Frequency Reference Standard
Keysight 11730A Power Sensor Cable (provided with 53147A/148A/149A)
Keysight 10503 series BNC (m) to BNC (m) Coaxial Cable
Small, non-metallic adjustment tool for slotted screw heads

NOTE

The instrument and the test equipment must be powered on for at least 30 minutes prior to beginning this calibration procedure. This allows the internal temperatures of the equipment to stabilize.

- 1 Connect an Keysight 10503 series coaxial cable from the output of your 10 MHz frequency standard to the Counter's **CHANNEL 1** input on the instrument's front panel.
- 2 Press the **Resol** key, and verify that the resolution is set to **1 HZ**. If necessary change the resolution to **1 HZ**.
- 3 If there is a label covering the calibration adjustment access hole, remove it (see [Figure 2-1](#)).

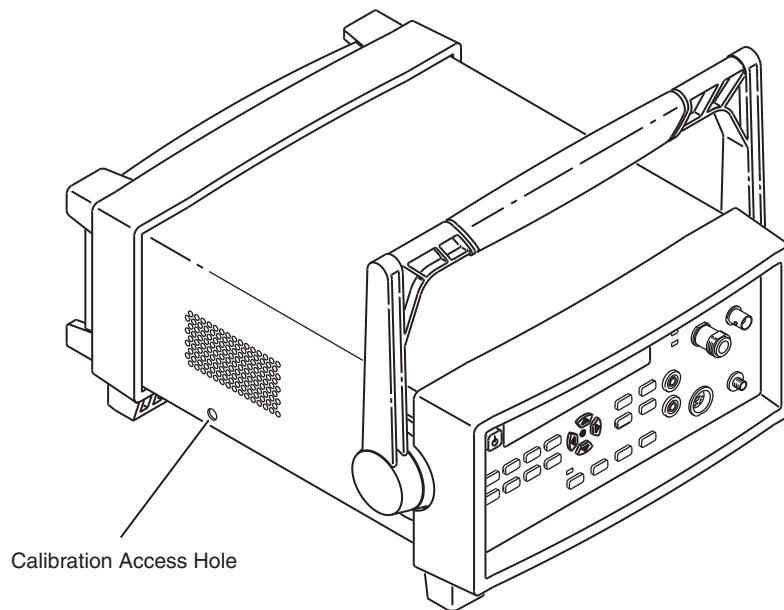

Figure 2-1 Calibrating the 10 MHz Frequency Reference Oscillator

- 4 Insert a non-metallic, slot-type adjustment tool through the hole near the bottom of the instrument's left side and into the slot in the timebase calibration screw.
- 5 Turn the calibration screw clockwise to increase the Counter's reading or counter-clockwise to decrease the reading until the frequency value displayed on the Counter's front panel is exactly **10,000,000 Hz**.

Power Reference Oscillator Frequency Calibration

The internal power reference oscillator is used to calibrate the Power Meter to the power sensor head. This adjustment calibrates the frequency output of the power reference oscillator to 50.0 MHz \pm 0.5 MHz.

Equipment Required

Keysight 53150A Microwave Frequency Counter
 Keysight 10503 series BNC (m) to BNC (m) Coaxial Cable
 Keysight E9635A Type N (m) to BNC (f) Adapter
 Small, non-metallic adjustment tool for slotted screw heads

NOTE

- The instrument and the test equipment must be powered on for at least 30 minutes prior to adjusting the power reference oscillator output. This allows the internal temperatures of the equipment to stabilize.
- This procedure specifies the Keysight 53150A for measuring the frequency output of the 53147A/148A/149A's power reference oscillator. If the 53147A/148A/149A's Frequency Counter is known to be in calibration (see **“Test 1: Channel 1 Frequency Sensitivity”** on page 31), you can use it in place of the 53150A in this procedure.
- Adjusting the power reference oscillator frequency may also affect the output level of the oscillator. Therefore, after you adjust the frequency to 50.0 MHz \pm 0.05 MHz, always check the output level and adjust it, if necessary, as described in **“Power Reference Oscillator Level Adjustment”** on page 66.

- 1 Turn off the Keysight 53147A/148A/149A, and disconnect the power cord.
- 2 Remove the shroud from the Keysight 53147A/148A/149A (see **“Removing the Shroud”** on page 96).
- 3 Position the Keysight 53147A/148A/149A on its right side so that you have access to the front panel and the left side of the main circuit board (see **Figure 2-2**).

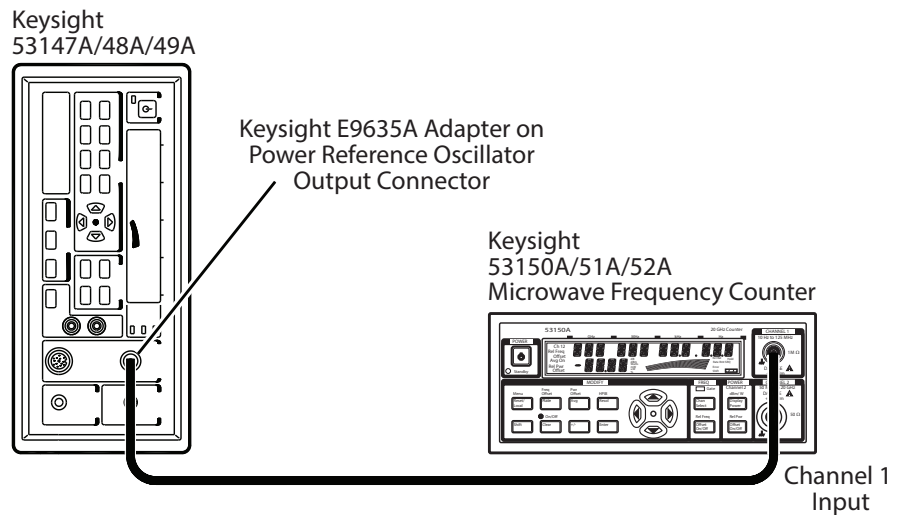

Figure 2-2 Reference Oscillator Frequency Adjustment Setup

- 4 Connect the power cord to the Keysight 53147A/148A/149A and to a power outlet.

WARNING

DANGEROUS VOLTAGES ARE PRESENT INSIDE THE KEYSIGHT 53147A/148A/149A WHEN IT IS CONNECTED TO A POWER SOURCE. WORK VERY CAREFULLY AND AVOID CONTACT WITH INTERNAL COMPONENTS WHEN THE SHROUD IS REMOVED AND POWER IS APPLIED TO PREVENT INJURY OR DEATH FROM ELECTRICAL SHOCK.

CAUTION

Some internal components of the Keysight 53147A/148A/149A are subject to damage from electrostatic discharge (ESD), physical contact, and/or electrical short circuits. Work very carefully when the shroud is removed, and avoid all unnecessary contact with the internal components.

- 5 Turn on the Keysight 53147A/148A/149A and then wait for at least 30 minutes to allow the internal temperature of the instrument to stabilize.
- 6 Connect an Keysight E9635A adapter to the Power Meter **OUTPUT** connector as shown in [Figure 2-2](#).

- 7 Connect an Keysight 10503 series cable from the Keysight E9635A adapter on the Keysight 53147A/148A/149A's Power Meter **OUTPUT** connector to the **CHANNEL 1** input connector on the Keysight 53150A/51A/52A Frequency Counter.
- 8 Set the Keysight 53150A/51A/52A Frequency Counter to measure frequency on Channel 1.
- 9 Turn on the Keysight 53147A/148A/149A's internal power reference oscillator:
Press **Shift + Menu**, use the up and/or down arrow keys to cycle through the menu to **PWR REF**, press the right-arrow key, then use the up or down arrow key to change the setting to **ON**, and press the **Enter** key. The **Pwr Ref** annunciator should now be activated.

NOTE

The reference oscillator is normally off. It is turned on automatically during calibration and then turned back off when calibration is complete. Setting **PWR REF** in the 53147A/148A/149A's menu to **ON** turns the power reference oscillator on, and it remains on until the **PWR REF** menu setting is returned to **OFF**. When you calibrate the Power Meter with **PWR REF** set to **ON**, the power reference oscillator remains on after calibration is complete.

- 10 Insert a small, non-conductive, slot-type adjustment tool into the hole in the side of the power reference oscillator shield (see [Figure 2-3](#)). This opening allows access to L9, the adjustable inductor that is used to adjust the frequency of the power reference oscillator.

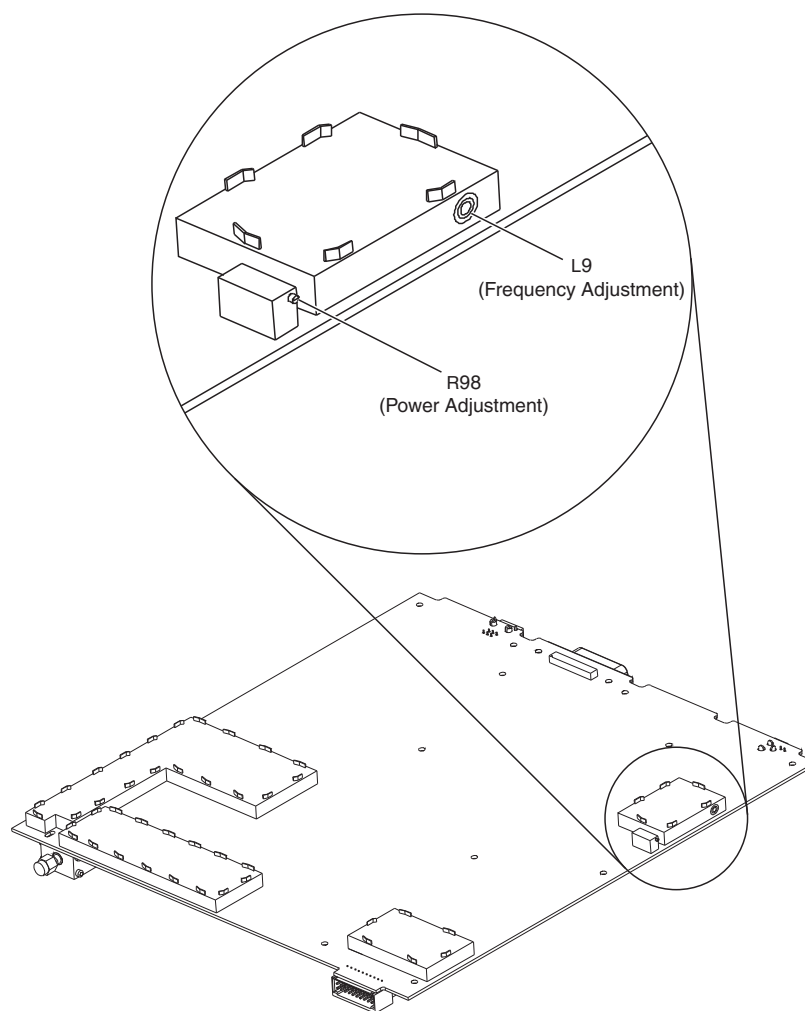

Figure 2-3 Power Reference Oscillator Adjustment Locations

- 11 Set the frequency to $50.0 \text{ MHz} \pm 0.05 \text{ MHz}$ (49.95 MHz to 50.05 MHz). Turn the adjustment tool counter-clockwise to increase the frequency or clockwise to decrease the frequency.

Power Reference Oscillator Level Adjustment

Two methods for calibrating the level of the Power Meter reference signal are provided in this section. Both methods provide acceptable results, and either one can be used.

Method 1

Equipment Required

Keysight E4418B Power Meter

Keysight 8481A Power Sensor

Keysight 11730A Power Sensor Cable (supplied with 53147A/148A/149A)

NOTE

- To ensure that the results are valid, the Keysight 53147A/148A/149A and the test equipment should be powered on for at least 30 minutes prior to beginning the calibration procedure. This allows the internal temperatures of the equipment to stabilize.
- The calibration of the Keysight E4418B Power Meter must be no more than one level removed from NIST (National Institute of Standards and Technology). If the E4418B Power Meter's calibration is more than one level removed from NIST, the test results will be invalid.
- This test is appropriate for the Keysight 53147A, 53148A, and 53149A.

- 1 Connect the Keysight 11730A Power Sensor Cable to the Keysight 8481A Power Sensor (see [Figure 2-4](#)).

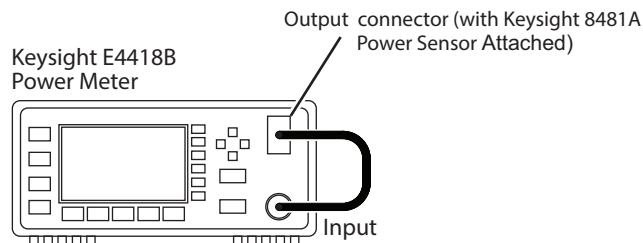

Figure 2-4 E4418B Power Meter Zeroing and Calibration Test Setup

- 2 Connect the free end of the Keysight 11730A Power Sensor Cable to the input connector on the Keysight E4418B Power Meter.
- 3 Connect the Keysight 8481A Power Sensor to the power reference output connector of the Keysight E4418B Power Meter.
- 4 Zero the E4418B Power Meter.
- 5 Calibrate the E4418B Power Meter.
- 6 Disconnect the Keysight 8481A Power Sensor from the Keysight E4418B Power Meter, and immediately connect it to the Power **OUTPUT** connector on the Keysight 53147A/148A/149A (see [Figure 2-5](#)).

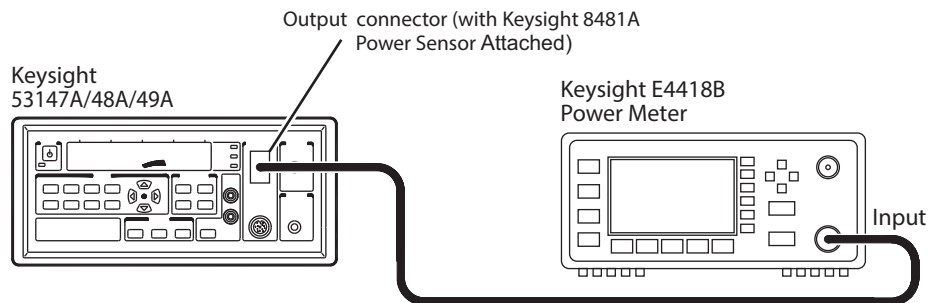

Figure 2-5 Power Meter Reference Level Test Setup

- 7 Use a non-metallic, slot-type adjustment tool to adjust the setting of R98 on the main circuit board (see [Figure 2-3](#)) until the power level is as close to 1.000 mW as possible (the level must be between 0.988 mW and 1.012 mW). Turn the adjustment tool counter-clockwise to increase the power level or clockwise to decrease the power level.

Method 2

Equipment Required

Keysight 432A Power Meter
 Keysight 478A-H75 or 478A-H76 Thermistor Mount
 Keysight 34401A Digital Multimeter
 Keysight 8120-1082 Power Sensor Cable

NOTE

To ensure that the results are valid, the Keysight 53147A/148A/149A and the test equipment should be powered on for at least 30 minutes prior to beginning the calibration procedure. This allows the internal temperatures of the equipment to stabilize.

- 1 Make sure the Keysight 432A Power Meter is off. Do not turn it on until instructed to do so.
- 2 Set the Keysight 34401A Digital Multimeter to measure resistance, and connect the DVM test prods between the center pin of the **V_{RF}** connector on the Keysight 432A Power Meter rear panel and pin 1 on the thermistor-mount end of the Keysight 8120-1082 Power Sensor Cable (see [Figure 2-6](#) to locate pin 1).

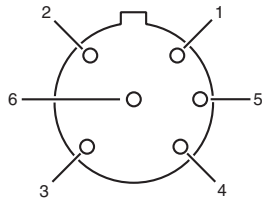

Figure 2-6 Keysight 8120-1082 Power Sensor Cable End View

- 3 Round off the resistance reading to two decimal places and keep a record of this value as R. It is the internal bridge resistance (R) of the Keysight 432A Power Meter (this should be approximately 200.3 ohms).
- 4 Connect the Keysight 478A-H75 or 478A-H76 Thermistor Mount to the Keysight 53147A/148A/149A Power Meter **OUTPUT** connector, as shown in [Figure 2-7](#).

NOTE

Do not use a cable between the Thermistor Mount and the 53147A/148A/149A Power Meter **OUTPUT** connector. Connect the Thermistor Mount directly to the **OUTPUT** connector.

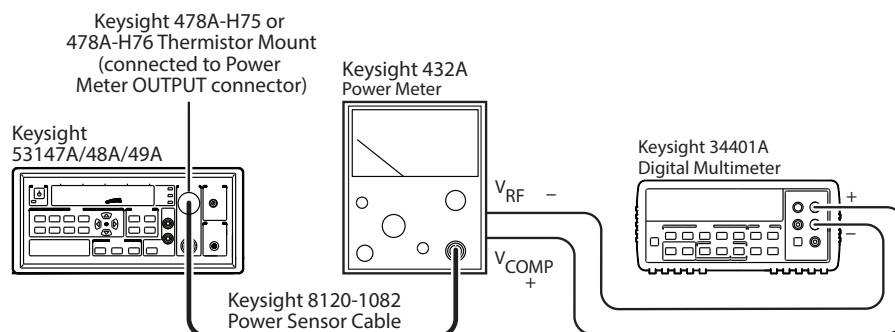

Figure 2-7 Power Meter Reference Level Calibration Setup

- 5 Connect the Keysight 8120-1082 Power Sensor Cable between the Thermistor Mount and the input connector on the Keysight 432A Power Meter.
- 6 Turn on the 432A Power Meter. Wait 30 minutes for the Power Meter and the Thermistor Mount to stabilize before proceeding to the next step.
- 7 Set the 432A Power Meter's **RANGE** switch to **Coarse Zero**.
- 8 Adjust the **COARSE ZERO** control on the 432A Power Meter's front panel to obtain a zero reading on the meter.
- 9 Set the 432A Power Meter's **RANGE** switch to **.01 mW / -20 dBm**.
- 10 Press the **FINE ZERO** control on the 432A Power Meter's front panel down to obtain a zero reading on the meter.
- 11 Set the 432A Power Meter's **RANGE** switch to **1 mW**.
- 12 Set the Digital Multimeter to measure microvolts.

CAUTION

Ensure that the Keysight 34401A Digital Multimeter's input leads are isolated from chassis ground before performing the next step.

- 13** Connect the positive test prod from the Keysight 34401A Multimeter to the **V_{COMP}** connector on the Keysight 432A Power Meter rear panel.

NOTE

The **V_{COMP}** and **V_{RF}** connectors are BNC female. You can use two BNC-to-banana jack adapters and two BNC cables to make it easier to connect the Multimeter to the Power Meter.

- 14** Connect the negative test prod from the Keysight 34401A Multimeter to the **V_{RF}** connector on the 432A Power Meter's rear panel.
- 15** If the reading on the Multimeter is less than 400 microvolts, proceed to step 16. If the reading is 400 microvolts or more, press the **FINE ZERO** toggle switch on the 432A Power Meter's front panel down.
- 16** Observe the reading on the Multimeter, round off the reading to the nearest microvolt, and keep a record of this value as V_0 .
- 17** Turn on the Keysight 53147A/148A/149A's internal power reference oscillator:
Press **Shift + Menu**, use the up and/or down arrow keys to cycle through the menu to **PWR REF**, press the right-arrow key, then use the up or down arrow key to change the setting to **ON**, and press the **Enter** key. The **Pwr Ref** annunciator should now be activated.

NOTE

The reference oscillator is normally off. It is turned on automatically during calibration and then turned back off when calibration is complete. Setting **PWR REF** in the 53147A/148A/149A's menu to **ON** turns the power reference oscillator on, and it remains on until the **PWR REF** menu setting is returned to **OFF**. When you calibrate the Power Meter with **PWR REF** set to **ON**, the power reference oscillator remains on after calibration is complete.

- 18** Observe the reading on the Multimeter, and keep a record of this value as V_1 .
- 19** Disconnect the Multimeter's negative test lead from the 432A Power Meter's **V_{RF}** connector, and connect it to the 432A Power Meter's chassis ground.
- 20** Observe the reading on the Multimeter, and keep a record of this value as V_{COMP} .

- 21** Calculate the output level of the 53147A/148A/149A's power reference oscillator (P_{rf}) using the following formula:

$$P_{rf} = \frac{2 V_{comp} (V_1 - V_0) + V_0^2 - V_1^2}{4R \text{ (Calibration Factor)}}$$

Where:

- P_{rf} = Power reference oscillator output level
 V_{comp} = previously recorded value
 V_1 = previously recorded value
 V_0 = previously recorded value
 R = previously recorded value
Calibration Factor = value for thermistor mount at 50 MHz (traceable to NIST)

NOTE

The following is an example showing how a calculation of the Power Reference Output Level is performed:

$$R = 200 \Omega$$

$$V_0 = 170 \mu V \text{ or } 170 \times 10^{-6} V$$

$$V_1 = 78,107 \mu V \text{ or } 78,107 \times 10^{-6} \text{ or } .078 V$$

$$V_{comp} = 5.1583 V$$

$$R = \text{previously recorded value}$$

$$\text{Calibration Factor} = 99.68\%$$

$$P_{rf} = \frac{2 V_{comp} (V_1 - V_0) + V_0^2 - V_1^2}{4R (\text{Calibration Factor})}$$

Note that V_0 is eventually dropped out of the equation in the following steps, because its value is very small (effectively zero).

$$\begin{aligned} P_{rf} &= \frac{2 (5.1583) (.078 - 0)^2 + (.000170)^2 - (0.78)}{4(200) (99.68\%)} \\ &= \frac{0.80469 - 0.00608}{797.44} = \frac{0.79861}{797.44} \\ &= 1.00147 \text{ mW} \end{aligned}$$

- 22** Use a non-metallic, slot-type adjustment tool to adjust the setting of R98 on the main circuit board (see [Figure 2-3](#)) until P_{rf} is between 0.988 mW and 1.012 mW. Turn the adjustment tool counter-clockwise to increase the power level or clockwise to decrease the power level.

DVM Calibration

The DVM calibration procedure is semi-automatic in that it is accomplished via software embedded in the Keysight 53147A/148A/149A. A computer and an RS-232 serial cable are required to access the calibration software.

Equipment Required

A computer with an RS-232 serial interface and terminal software
Keysight 53150-60215 RS-232 Serial Cable
Keysight 6613C or 6614C Precision DC Power Supply

NOTE

To ensure that the results are valid, the Keysight 53147A/148A/149A and the Keysight 6613C/6614C Precision DC Power Supply should be powered on for at least 30 minutes prior to beginning the calibration procedure. This allows the internal temperatures of the equipment to stabilize.

- 1 Press the **Display DVM** key on the Keysight 53147A/148A/149A.
- 2 Connect the DVM test leads to the DVM + and – connectors on the Keysight 53147A/148A/149A (red to + and black to –).
- 3 Connect the test prods to the + and – output connectors on the Keysight 6613C/6614C Precision DC Power Supply.
- 4 Set the 6613C/6614C Precision DC Power Supply to output exactly + 50.0 V.
- 5 Connect the Keysight 53150-60215 RS-232 Serial Cable between the computer's serial port (DB-25) and the Keysight 53147A/148A/149A's serial port (RJ-45).
- 6 Start the terminal software on the computer.
- 7 Send "**!acq 60**" from the terminal program to the Keysight 53147A/148A/149A (be sure to type lowercase letters when typing "**!acq 60**").
- 8 Press "**5**" on the computer to choose option 5 from the **DMM Tests** menu (see [Figure 2-8](#)).

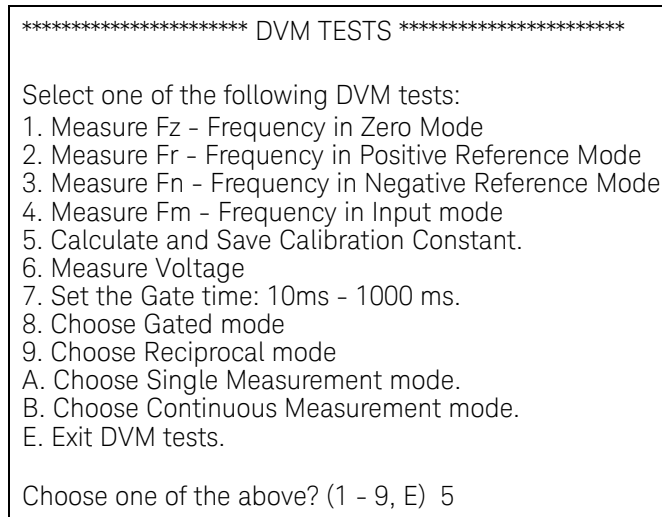

Figure 2-8 DVM Tests Main Menu

- 9 When the calibration program displays:
Apply 50.000 Volts Reference to the DVM. Ready? (y/n) y
type “y”.
- 10 When the calibration program displays:
Update from old 10974.12 to new 10974.1 Cal. Constant? (y/n) y
type “y” (the values in the display line above are simulated).
- 11 When the calibration program displays:
Apply -50.000 Volts Reference to the DVM. Ready? (y/n) y
- 12 Reverse the connection of the test prods in the + and – output connectors on the Keysight 6613C/6614C Precision DC Power Supply (red to – output, black to + output), or reverse the polarity of the power outputs.
- 13 Type “y”.
- 14 When the calibration program displays:
Update from old 10974.01 to new 10974.96 Cal. Constant? (y/n) y
type “y” (the values in the display line above are simulated).

- 15** When the calibration program redisplay its menu (as shown in [Figure 2-8](#)), type “e” to exit the program.
- 16** Close the terminal program and disconnect the serial cable from the computer and the instrument.

Pre-Troubleshooting Information

This section contains the following pertinent troubleshooting information:

- Safety Considerations
- Recommended Test Equipment
- Repair Considerations
- After Service Considerations
- Assembly Identification and Location

Safety Considerations

Although this instrument has been designed in accordance with international safety standards, this guide contains information, cautions, and warnings which must be followed to ensure safe operation and to retain the instrument in a safe condition. Service instructions, and adjustment procedures requiring removal of the instrument cover, are for use by service-trained personnel only. To avoid dangerous electric shock, do not perform any servicing or make any adjustments with the cover removed, unless qualified to do so.

WARNING

BEFORE APPLYING AC POWER, THE INSTRUMENT AND ALL PROTECTIVE EARTH TERMINALS, EXTENSION CORDS, AUTO TRANSFORMERS, AND DEVICES CONNECTED TO THE INSTRUMENT SHOULD BE CONNECTED TO A PROTECTIVE EARTH GROUNDED SOCKET.

ANY INTERRUPTION OF THE PROTECTIVE GROUNDING CONDUCTOR INSIDE OR OUTSIDE THE INSTRUMENT OR DISCONNECTION OF THE PROTECTIVE EARTH TERMINAL WILL CAUSE A POTENTIAL SHOCK HAZARD THAT COULD RESULT IN PERSONAL INJURY. INTENTIONAL INTERRUPTION IS PROHIBITED.

Any maintenance and repair of the opened instrument under voltage should be avoided as much as possible and, if necessary, should be carried out only by a skilled person who is aware of the hazards involved (for example, fire and electric shock).

Recommended Test Equipment

Test equipment recommended for testing and troubleshooting the Keysight 53147A/148A/149A is listed in [Chapter 1, “Performance Tests - Verifying Specifications”](#). Substitute equipment may be used if it meets or exceeds the required characteristics listed in [Table 1-1](#).

Repair Considerations

Electrostatic Discharge

Electronic components and assemblies in the Keysight 53147A/148A/149A can be permanently degraded or damaged by electrostatic discharge. Use the following precautions when servicing the instrument:

- 1 ENSURE** that static-sensitive devices or assemblies are serviced at static-safe work stations providing proper grounding for service personnel.
- 2 ENSURE** that static-sensitive devices or assemblies are stored in static shielding bags or containers.
- 3 DO NOT** wear clothing subject to static-charge buildup, such as wool or synthetic materials.
- 4 DO NOT** handle components or assemblies in carpeted areas.
- 5 DO NOT** remove an assembly or component from its static shielding protection until you are ready to install it.
- 6 AVOID** touching component leads. (Handle by packaging only.)

Surface Mount Repair

None of the assemblies in the instrument that use surface-mount components can be repaired outside of authorized Keysight Service Centers. Any attempt to repair these assemblies voids the Keysight factory warranty.

Disassembly and Reassembly Specifics

Refer to Chapter 3 of this guide, [“Replacing Assemblies - Disassembly and Reassembly”](#) for complete disassembly and reassembly instructions, and Chapter 4, [“Replaceable Parts”](#) for an exploded view of the instrument’s parts.

After Service Considerations

Product Safety Checks

The following safety checks must be performed after any troubleshooting and repair procedures have been completed to ensure the safe operation of the instrument.

WARNING

THE RESISTANCE CHECKS DESCRIBED IN THE FOLLOWING TEXT REQUIRE THAT THE POWER CORD BE CONNECTED TO THE INSTRUMENT AND THAT AC POWER BE DISCONNECTED. BE SURE THAT THE POWER CORD IS NOT CONNECTED TO AN AC POWER SOURCE BEFORE PERFORMING ANY SAFETY CHECKS.

- 1 VISUAL INSPECTION.** Visually inspect the interior of the instrument for any signs of abnormal internally generated heat, such as discolored printed circuit boards or components, damaged insulation, or evidence of arcing. Determine and remedy the cause of any such condition.
- 2 GROUND CONTINUITY TEST.** Plug the power cord into the rear- panel power receptacle. (DO NOT connect the instrument to AC power at this time.) Using a suitable ohmmeter, check resistance from the instrument's metallic connection (such as the rear panel or BNC ground collar) to the ground pin on the power cord plug. The reading must be less than 1Ω . Flex the power cord while making this measurement to determine whether intermittent discontinuities exist.
- 3** Check any indicated front- or rear-panel ground terminals marked, using the above procedure.
- 4 INSULATION RESISTANCE TEST.** Tie the line and neutral pins of the power cord plug together. Measure the resistance from the instrument enclosure (chassis) to the line and neutral pins of the power cord plug. The minimum acceptable resistance is $2\text{ M}\Omega$. Replace any component which results in a failure.

Product Performance Checks

After replacement of any functional assembly, perform the operational verification test in Chapter 1 of this guide, "[Performance Tests - Verifying Specifications](#)"

Assembly Identification and Location

The assembly number, name, and Keysight part number of each of the Keysight 53147A, 53148A, and 53149A assemblies are listed in [Table 2-2](#). [Figure 2-9](#) illustrates the replaceable assemblies in the Keysight 53147A/148A/149A.

Table 2-2 Keysight 53147A/148A/149A Assembly Identification

Assembly Name	Keysight Part No.
A1 Adapter (53149A only)	53152-80001
A2 Front Panel Assembly (53147A)	53147-60207
A2 Front Panel Assembly (53148A)	53148-60207
A2 Front Panel Assembly (53149A)	53149-60207
A3 Front Panel Power Switch Assembly (Power/Standby Switch)	53147-20203
A4 Battery Housing Assembly ^[a]	53150-00002
A5 DC/DC Converter PCB ^[a]	53150-60004
A6 Battery Switch Assembly ^[a]	53147-60223
A7 Battery ^[a]	53150-80010
A8 Battery Sled Assembly ^[a]	53150-00004
A9 Battery Cover Assembly	53150-00003
A10 Power Entry Module Assembly	53147-40007
A11 Rear Panel Assembly	53147-60219
A12 Cooling Fan Assembly	53147-80012
A13 Power Supply Assembly	0950-3299

[a] With Option 002 (Battery Option) only.

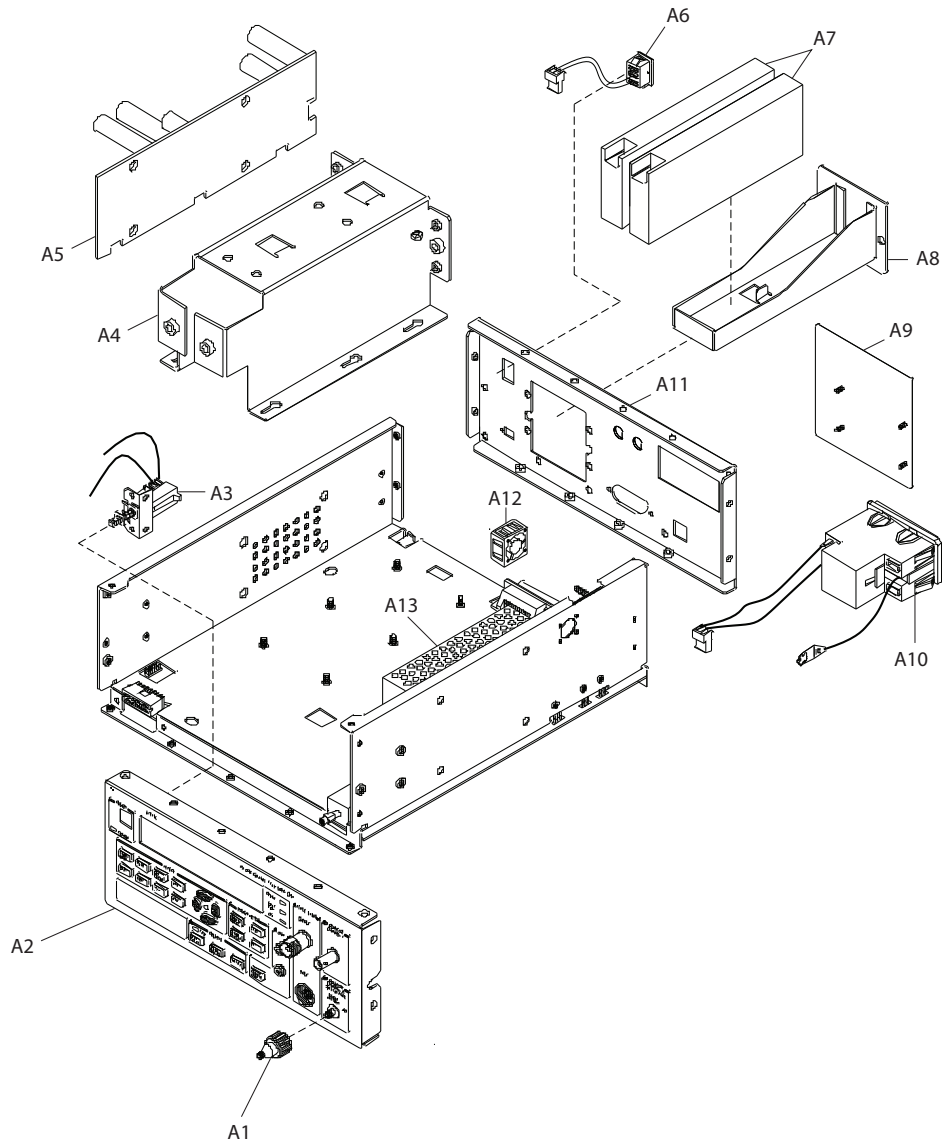

Figure 2-9 Replaceable Assembly Locations – Top Internal View

Troubleshooting the Instrument

Power Supply Check

WARNING

HAZARDOUS VOLTAGES ARE PRESENT ON THE POWER SUPPLY ASSEMBLY. ONLY TRAINED AND QUALIFIED SERVICE PERSONNEL SHOULD PERFORM THE FOLLOWING PROCEDURE.

- 1 Remove the power cord from the back of the instrument.
- 2 Remove the cover as described in Chapter 3.

NOTE

The DC Power Supply Assembly is fused for safety reasons. It must be assumed that, if the fuses are blown, the power supply has probably suffered damage and has therefore become unreliable. If the power supply fails, it must be replaced, even if the fuse in the power supply appears to be all that has failed.

- 3 Connect the instrument to the power source.
- 4 Connect the negative lead of a voltmeter to the chassis and measure each of the voltages listed in [Table 2-3](#) on Power Supply connectors TB1 and TB2 (see [Figure 2-10](#)).

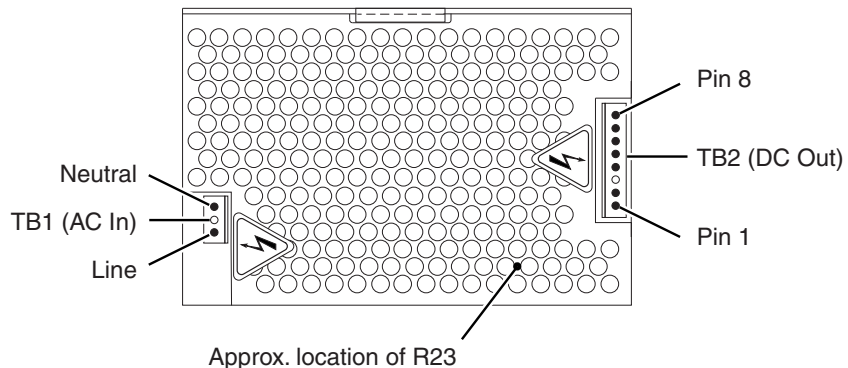

Figure 2-10 A4 DC Power Supply Test-Point Locations

Table 2-3 lists A4 Power Supply's input and output voltages, the corresponding wire color for each input and output, and the tolerances specified for these voltages.

Table 2-3 A4 Power Supply Inputs and Outputs

Input/Output Voltage	Connector and Pin Designation	Wire Color	Tolerance
AC-input (neutral) 0 VAC ^[a]	TB1, pin N	blue	–
AC-input (line in) 85 - 264 VAC ^[a]	TB1, pin L	brown	–
–15.0 VDC @ 0.7 A max.	TB2, pin 1	lavender	±3%
0.0 VDC (ground for –15 VDC)	TB2, pin 2	brown	–
N/A (unused)	TB2, pin position 3 (no pin)	N/A	–
N/A (unused)	TB2, pin 4		
+15.0 VDC @ 2 A max.	TB2, pin 5	blue	±5%
0.0 VDC (ground for +15 VDC)	TB2, pin 6	brown	–
+5.0 VDC @ 5A max.	TP 13 (bottom of motherboard)	red	±1%
0.0 VDC (ground for +5 VDC)	TB2, pin 8	black	–

[a] AC-input values are referenced to chassis ground.

Adjusting the +5 VDC Output

The +5 VDC output of the power supply is adjustable. If this voltage is found to be outside of the tolerance range listed in **Table 2-3**, it can be adjusted using R23, which is visible on the top surface of the power supply's circuit board. When adjusting the +5 VDC output, use a nonmetallic or insulated adjustment tool.

Self-Test

The instrument performs a Self-Test procedure when it is powered on. The Self-Test can also be invoked from the instrument's Menu.

Running the Self Test

- 1 Disconnect all cables connected to the instrument's front and rear signal connectors.
- 2 Connect the power cord to the power input connector on the instrument's rear panel and to an appropriate power source.
- 3 Press and release the **Power** button on the front panel.
- 4 Observe the front-panel display and note any error messages displayed.
- 5 When **CH 2 NO SIGNAL** is displayed, press and release the **Shift** key, and then press and release the **Menu** key.
- 6 Press the up-arrow key or the down-arrow key repeatedly until DO SELF TEST is displayed, and then press and release the **Enter** key.
- 7 Observe the front-panel display and note any error messages displayed.

Self Test Error Messages

Table 2-4 lists and describes messages that are generated by the instrument during Self-Test to indicate whether a component passed or failed its test. These messages are sent via the RS-232 serial output only—they do not appear on the instrument's front-panel display.

Table 2-4 Self-Test Messages

Message	Description
ROM TEST FAIL ROM TEST OK	ROM failed read test. ROM passed read test.
RAM DATA LINES OK RAM DATA ERROR RAM ADDR LINES OK RAM ADDR ERROR RAM TEST OK	RAM data lines passed test. RAM data lines failed test. RAM address lines passed test. RAM address lines failed test. RAM tests completed with no errors detected.
EEPROM FAIL - CONFIGURATION DATA	The configuration data saved in EEPROM memory is defective.
ROM FAIL; Computed checkbyte does not match the value stored in EEPROM.	The checksum of the ROM data does not match the value stored in EEPROM.
EEPROM FAIL - CONFIGURATION DATA; Needs to be (re)initialized.	The EEPROM org code does not verify with current revision of ROM code.
EEPROM FAIL - POWER CAL DATA; Using default data	The checksum of the EEPROM power-calibration table is bad. Factory default calibration data will be used.
EEPROM FAIL - SAVED SETTINGS; Using default data	The checksum of the user settings stored in EEPROM is bad. Factory default settings will be used.
EEPROM FAIL - SAVED SETTINGS; Invalid EEPROM SAV n Data.	The checksum of one set of user settings (1 – 9) stored in EEPROM is bad.
GPIB FAIL; Conf. Test	The GPIB hardware failed its confidence test.

Table 2-5 and Table 2-6 list and describe the messages that are generated by the instrument during Self-Test or during operation to indicate that a problem has been detected. These messages are displayed on the instrument's front-panel display and are also sent via the RS-232 serial output (in many cases, the exact message text that is displayed on the front panel is a condensed form of the message that is sent via RS-232).

Table 2-5 Front Panel Display Error Messages

Message	Description
12V FAIL	The +12 VDC output from the power supply is not within specifications.
-12V FAIL	The -12 VDC output from the power supply is not within specifications.
-5V FAIL	The -5 VDC output from the power supply is not within specifications.
ADC FAIL	Failure detected in the ADC.
PATH FAIL	Failure detected in the Channel 1 signal path.
THRS FAIL	Failure detected in the Channel 1 threshold circuit.
THRS FAIL	Failure detected in the Channel 2 RF threshold circuit.
THRS THRU	Failure detected in the Channel 2 through-path threshold circuit.
THRS HET	Failure detected in the Channel 2 heterodyne-path threshold circuit.
EEP WRT FAIL	Failure detected while writing to EEPROM.
FPANEL FAIL	The front panel or its interconnecting cable is defective or not properly connected.
FPGA FAIL	Failure detected in the FPGA (Field Programmable Gate Array).
GPIB FAIL	Failure detected in the GPIB hardware.
HET PATH FAIL	Failure detected in the heterodyne-path circuit.
IIC FAIL	An attempt to write to the LCD display failed.
INSTCFG FAIL	The instrument's configuration data is missing or has become corrupted.
OVERTEMP	The instrument's internal temperature is above the acceptable limit.
PWR CAL FAIL	The instrument's power-calibration data is missing or corrupted.
PWR CKT FAIL	Failure detected in the Channel 2 power-measurement circuit.
RAM FAIL	Failure detected in RAM.
ROM FAIL	Failure detected in ROM.
SAV SET FAIL	One or more of the sets of user settings is missing or is corrupted.
SERVICE FAIL	The instrument's service data is missing or has become corrupted.
THRU FAIL	Failure detected in the through-path circuit of Channel 2.
VCO/CNT FAIL	Failure detected in the VCO or the Count Chain.

Table 2-6 RS-232 Error Messages

Message	Description
12V FAIL	The +12 VDC output from the power supply is not within specifications.
-12V FAIL	The -12 VDC output from the power supply is not within specifications.
-5V FAIL	The -5 VDC output from the power supply is not within specifications.
ADC FAIL	Failure detected in the ADC.
B1 SIGNAL PATH FAIL	Failure detected in the Channel 1 signal path.
B1 THRESHOLD FAIL	Failure detected in the Channel 1 threshold circuit.
B2 RF THRESHOLD FAIL	Failure detected in the Channel 2 RF threshold circuit.
B2 THROUGH-PATH THRESHOLD FAIL	Failure detected in the Channel 2 through-path threshold circuit.
B2 HETERODYNE PATH THRESHOLD FAIL	Failure detected in the Channel 2 heterodyne-path threshold circuit.
EEPROM FAIL - WRITE	Failure detected while writing to EEPROM.
FRONT PANEL FAIL	The front panel or its interconnecting cable are defective or not properly connected.
FPGA FAIL	Failure detected in the FPGA (Field Programmable Gate Array).
GPIB FAIL	Failure detected in the GPIB hardware.
HETERODYNE PATH FAIL	Failure detected in the heterodyne-path circuit.
IIC FAIL	An attempt to write to the LCD display failed.
INSTCFG FAIL	The instrument's configuration data is missing or corrupted.
OVER TEMPERATURE	The instrument's internal temperature is above the limit.
PWR CAL FAIL	The instrument's power-calibration data is missing or corrupted.
POWER METER FAIL	Failure detected in the Channel 2 power-measurement circuit.
RAM FAIL	Failure detected in RAM.
ROM FAIL	Failure detected in ROM.
SAV SET FAIL	One or more of the sets of user settings is missing corrupted.
SERVICE FAIL	The instrument's service data is missing or corrupted.

Table 2-6 RS-232 Error Messages (continued)

Message	Description
THRU PATH FAIL	Failure detected in the through-path circuit of Channel 2.
VCO/COUNT CHAIN FAIL	Failure detected in the VCO or the Count Chain.

THIS PAGE HAS BEEN INTENTIONALLY LEFT BLANK.

3 Replacing Assemblies – Disassembly and Reassembly

Introduction	90
Tools Required	91
Do This First	92
Removing the Bumpers	93
Removing the Handle	94
Removing the Bumper Retainers	95
Removing the Shroud	96
Removing the Front Panel Assembly	98
Removing the Rear Panel Assembly	101
Removing the Cooling Fan	103
Removing the Power Supply	104

Introduction

This chapter provides instructions for removing major assemblies in the Keysight 53147A/148A/149A. To install an assembly, apply the removal instructions in reverse.

The following disassembly and repair procedures are provided:

- “Removing the Bumpers” pg. 93
- “Removing the Handle” pg. 94
- “Removing the Bumper Retainers” pg. 95
- “Removing the Shroud” pg. 96
- “Removing the Front Panel Assembly” pg. 98
- “Removing the Rear Panel Assembly” pg. 101
- “Removing the Cooling Fan” pg. 103
- “Removing the Power Supply” pg. 104

WARNING

HAZARDOUS VOLTAGES ARE PRESENT ON THE POWER SUPPLY ASSEMBLY. DISCONNECT THE INSTRUMENT FROM THE POWER SOURCE, AND WAIT AT LEAST SIX MINUTES BEFORE WORKING INSIDE THE INSTRUMENT.

CAUTION

Do not replace assemblies when the instrument is operating to prevent damage to components.

NOTE

Unless otherwise stated, directional referents in the procedures in this chapter are accurate when viewing the instrument from the front.

Part numbers for all replaceable parts and assemblies are provided in [Chapter 4, “Replaceable Parts”](#).

Tools Required

The following tools are required for the removal/replacement procedures in this chapter:

- #1 Phillips screwdriver
- #2 Phillips screwdriver
- TORX® 15 (T15) hand screwdriver
- 1/4-inch open-end or box wrench
- 1/4-inch nut driver
- 5/16-inch nut driver
- 7 mm nut driver
- Needle-nose pliers

Do This First

Perform the following steps before beginning any of the removal and replacement procedures:

- 1 If the instrument is on, press and release the POWER button on the front panel.
- 2 Disconnect the AC power cord from the AC input socket on the rear panel.
- 3 If the instrument has the Battery Option (002) installed, remove the battery sled, and disconnect any DC input cable from the EXT DC connector on the rear panel.

CAUTION

While most of the hardware used in the instrument is SAE, the six TORX screws that attach the handle mounts to the instrument are metric. To avoid damage to the threaded holes in the chassis that handle mount screws fit in, be sure to use the correct screws.

Removing the Bumpers

Use the following procedure to remove the front and rear protective bumpers:

- 1 Remove the rear bumper by lifting the inner edge of the bumper away from the shroud near one corner at the top and one side and pulling that corner away from the instrument. Repeat the process with the remaining corners until the bumper is free of the instrument.



Figure 3-1 Removing the Bumpers

- 2 Use the same procedure (as in Step 1) to remove the front bumper.

NOTE

The bumpers can be used to support and protect the instrument after the shroud is removed. Place both bumpers on their inner edges on your work surface, and then place the instrument on top of them. The rear bumper can also serve as a holder for the instrument (once the bumper retainers are removed) when you need to position it upright on either end.

Removing the Handle

Use the following procedure to remove the carrying handle:

- 1 Remove the front bumper (see “Removing the Bumpers” on page 93).
- 2 Stand the instrument on end on its back bumper.
- 3 Position the handle so that it is against the top surface of the shroud (see Figure 3-2).

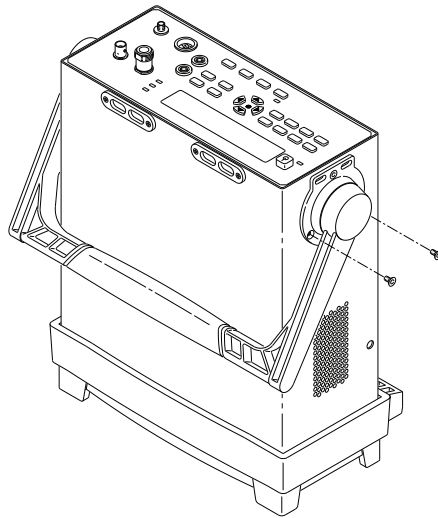

Figure 3-2 Removing the Handle

- 4 Use a T15 TORX screwdriver to remove two of the 8-32 x 1/4-inch handle mounting screws (remove the two screws that are closest to the back of the instrument).
- 5 Repeat Step 4 for the other handle mount.
- 6 While holding the handle to support it, remove the remaining two screws (one on each handle mount).
- 7 Remove the handle.

Removing the Bumper Retainers

Use the following procedure to remove the bumper retainers:

- 1 Remove the front and rear bumpers (see “Removing the Bumpers” on page 93).
- 2 Use a #1 Phillips screwdriver to remove the two 4-40 x 7/16-inch flathead machine screws that attach each bumper retainer to the chassis (see Figure 3-3).

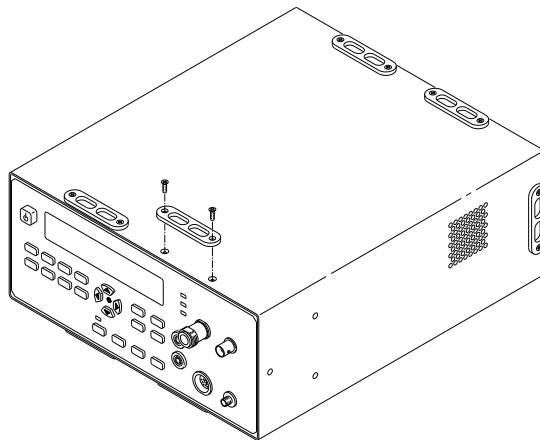

Figure 3-3 Removing the Bumper Retainers

- 3 Repeat Step 2 for each bumper retainer you need to remove.

CAUTION

When all of the bumper-retainer screws and the handle are removed, the shroud is not attached to the chassis. Exercise caution when moving the instrument in this condition to prevent the chassis from sliding out of the shroud. If you do not intend to remove the shroud, insert the bumper retainer screws in the holes they were removed from (the holes are countersunk to accept the screws, and the screws can safely be inserted fully into the holes).

Removing the Shroud

Use the following procedure to remove the shroud:

WARNING

WHEN THE SHROUD IS REMOVED FROM THE COUNTER, DANGEROUS LINE VOLTAGES THAT CAN CAUSE SERIOUS INJURY ARE EXPOSED. ALWAYS DISCONNECT THE POWER CORD BEFORE REMOVING THE SHROUD.

- 1 Remove all detachable connector fittings and/or adapters from the connectors on the instrument's front panel.
- 2 Remove the front and rear bumpers (see ["Removing the Bumpers"](#) on page 93).

NOTE

The bumpers can be used to support and protect the instrument after the shroud is removed. Place both bumpers on their inner edges on your work surface, and then place the instrument on top of them. The rear bumper can also serve as a holder for the instrument (once the bumper retainers are removed) when you need to position it upright on either end.

- 3 Remove the handle (see ["Removing the Handle"](#) on page 94).
- 4 Remove the four bumper retainers from the front end of the instrument (see [Figure 3-3](#) and ["Removing the Bumper Retainers"](#) on page 95).
- 5 Remove the six bumper retainers at the rear end of the chassis.

- 6 Slide the shroud off the chassis to the rear (see [Figure 3-4](#)), and place it aside (if the shroud does not slide easily off the chassis, press on the rear panel with one hand while pulling the shroud with the other hand).

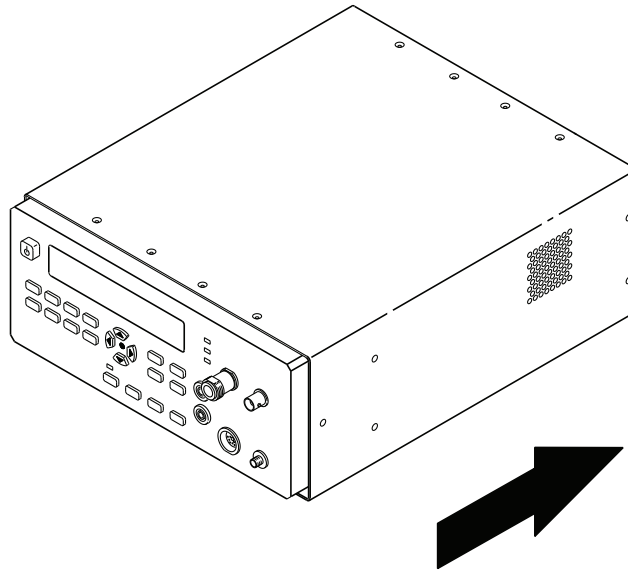

Figure 3-4 Removing the Shroud

Removing the Front Panel Assembly

Use the following procedure to remove the front panel assembly:

- 1 Remove the shroud (see “[Removing the Shroud](#)” on page 96).
- 2 Use a 5/16-inch wrench to loosen the nut that attaches the Power Meter output cable to the back of the Power Meter **OUTPUT** connector on the front panel assembly.
- 3 Disconnect the Power Meter output cable from the back of the Power Meter **OUTPUT** connector.
- 4 Disengage the Power Meter output cable from the cable clamp on the chassis floor near the right front corner of the chassis.
- 5 Disconnect the Power Meter input cable from J22, which is accessible through the rectangular opening in the chassis floor near the right-front corner of the chassis.
- 6 Disengage the Power Meter input cable from the cable clamp on the chassis floor near the right front corner of the chassis.
- 7 Disconnect the Power Meter **INPUT** connector’s ground wire (black) from the ground lug on the chassis floor.
- 8 Disconnect the Channel 1 input cable from J15, which is accessible through a hole in the chassis floor that is at the front of the chassis, behind the **Chan Select** key.
- 9 Disconnect the DVM input connector from J23, which is accessible through the square hole in the chassis floor approximately 1/3 of the way back from the front panel in line with the **Display DVM** key.
- 10 Use a microwave torque wrench to partially loosen the nut that connects the Channel 2 input connector to the sampler on the main circuit board.

CAUTION

Do not attempt to fully loosen the nut at this time. As soon as the nut turns freely, stop turning it, and proceed to the next step.

- 11 Remove the two 6-32 x ¼ flathead machine screws from the countersunk holes at the top-front corners of the chassis (see [Figure 3-5](#)).

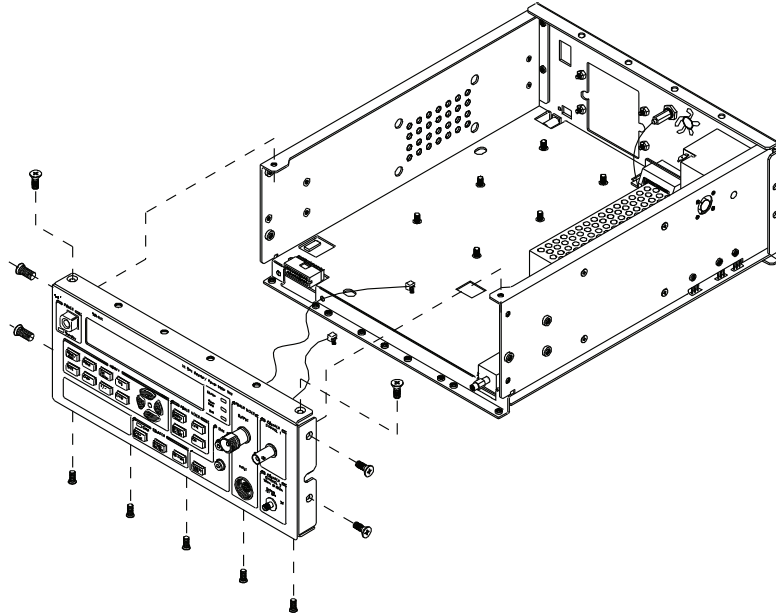

Figure 3-5 Removing the Front Panel Assembly

- 12 Remove the five 4-40 x ¼-inch flathead machine screws that attach the front-panel assembly to the bottom of the chassis.
- 13 Remove the two 6-32 x ¼-inch flathead machine screws from the countersunk holes at each side of the front the end of the chassis.
- 14 While holding the front panel assembly with one hand, use the fingers of your other hand to continue to loosen the nut on the Channel 2 input connector. Gently pull the front panel assembly away from the chassis as you loosen the nut until the front panel assembly is completely disconnected.

CAUTION

When reattaching the front panel assembly, reverse the procedure above. You *must* use a microwave torque wrench to tighten the nut that attaches the Channel 2 input connector to the sampler. Using any other tool to tighten the coupling nut will damage the connector, the sampler, or both.

Removing the Rear Panel Assembly

Use the following procedure to remove the rear panel assembly:

- 1 Remove the shroud (see “[Removing the Shroud](#)” on page 96).
- 2 If the Battery Option is *not* installed, remove the four 4-40 self-locking hex nuts that attach the battery opening cover to the rear panel (these nuts are accessible from inside the chassis). Remove the battery opening cover, and skip to Step 5.
- 3 If the Battery Option *is* installed, remove the battery sled from the Counter (for instructions on removing the battery sled, see Appendix C of the *Keysight 53147A/148A/149A Operating Guide*).
- 4 If the Battery Option is installed, remove the four 4-40 x 3/16-inch self-locking flathead machine screws that attach the rear panel assembly to the Battery Option chassis as shown in [Figure 3-6](#) (two screws on each side of the opening).

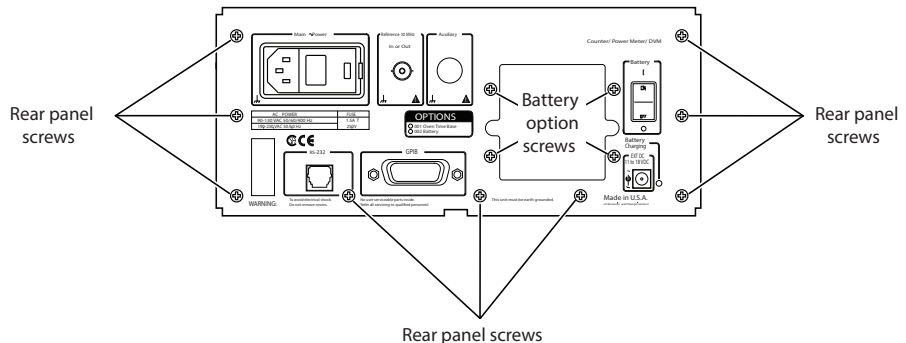

Figure 3-6 Rear Panel Assembly Screws

- 5 Remove the nine 4-40 x 3/16-inch self-locking flathead machine screws that attach the rear panel assembly to the chassis (see [Figure 3-6](#)).

NOTE

The screw in the lower-left corner of the rear panel assembly (as viewed from the rear of the Counter) may be covered by the serial-number sticker. If it is, carefully cut away the lower-left corner of the sticker to expose the screw head.

- 6 Disconnect the external-reference input/output cable (coaxial) from connector J8 on the main board. J8 is directly under the back edge of the power supply near the chassis wall.
- 7 A two-wire AC-input cable (brown and blue wires) runs between the AC input module on the rear-panel assembly and the connector that is accessible through the cutout in the front of the power supply enclosure (TB1). Disconnect this cable from the power supply.
- 8 If the Battery Option is installed, there is a two-wire cable (brown and white wires) that runs between the AC input module on the rear panel assembly and connector J3 on the Battery Option circuit board (J3 is the third connector from the back edge of the board). Disconnect this cable from J3 on the Battery Option circuit board.
- 9 Use a 5/16-inch nut driver to remove the self-locking hex nut that attaches the rear panel assembly grounding wire (green/yellow) to the right wall of the chassis. Slide the grounding lug off the welded stud on the chassis wall, and thread the lock nut back onto the stud a few turns until it is finger-tight.
- 10 Use a 7 mm nut driver to remove the two hex standoff screws that attach the GPIB connector to the rear panel assembly.

WARNING

AN ELECTRICAL SHOCK HAZARD EXISTS IF THE COUNTER IS OPERATED WITH THE REAR PANEL ASSEMBLY GROUNDING WIRE NOT PROPERLY CONNECTED TO THE CHASSIS. TO PREVENT SERIOUS INJURY AND/OR DAMAGE TO THE EQUIPMENT, NEVER OPERATE THE COUNTER UNLESS THIS GROUND WIRE IS SECURELY CONNECTED TO THE CHASSIS WALL AND THE REAR PANEL ASSEMBLY.

- 11 Carefully pull the rear panel assembly away from the back end of the chassis. Guide the cables that remain attached to the rear panel assembly as you remove it to prevent them from catching on other cables or other components of the Counter.

CAUTION

When reinstalling the rear panel assembly, position it carefully to avoid damage to the Battery Charging LED, the serial-port connector (RJ-12), the GPIB connector, and the main board. If these components are not correctly aligned with the openings in the back panel, they may be damaged.

Removing the Cooling Fan

Use the following procedure to remove the cooling fan:

- 1 Remove the shroud (see [“Removing the Shroud”](#) on page 96).
- 2 Disconnect the two-wire cooling-fan power cable (blue and red wires) from J16 on the main board. J16 is the connector that is closest to the rear panel assembly near the right chassis wall and behind the power supply (directly under the fan).
- 3 Use a #1 Phillips screwdriver and a 1/4-inch wrench or nut driver to remove the four 4-40 x 1-inch panhead machine screws and 1/4-inch self-locking hex nuts that attach the cooling fan to the chassis (see [Figure 3-7](#)).

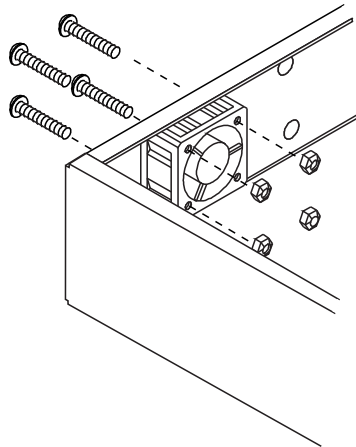

Figure 3-7 Cooling Fan Screws

- 4 While removing the cooling fan from the chassis, guide the cable to be sure it does not catch on other cables or other components of the instrument.

Removing the Power Supply

Use the following procedure to remove the power-supply:

- 1 Remove the shroud (see “Removing the Shroud” on page 96).
- 2 Place the rear bumper face-down on your work surface (the portion of the bumper that normally fits around the end of the instrument should be facing up).
- 3 Carefully position the instrument on end with the front panel inserted into the bumper.
- 4 Disconnect the two power-supply connectors (one at the front and one at the rear of the power supply).
- 5 While holding the power supply in position, use a #2 Phillips screwdriver to remove the four countersunk flathead screws that fasten the power supply to the side wall of the chassis (see Figure 3-8).

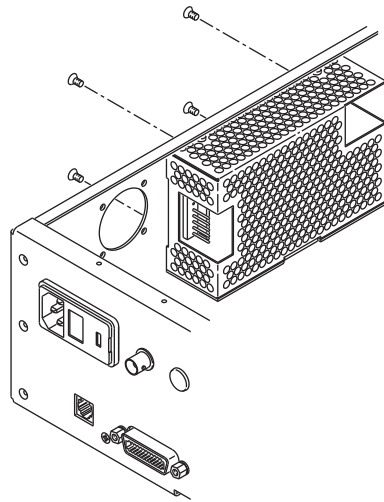

Figure 3-8 Removing the Power Supply

- 6 Remove the power supply.
- 7 Install the replacement power supply by reversing the instructions in Steps 1 through 6.

- 8** Turn the instrument on, and perform the “Power Supply Check” procedure on page 81.
- 9** If necessary, adjust the +5 VDC output of the power supply using the procedure titled “Adjusting the +5 VDC Output” on page 82.
- 10** Reassemble the instrument.

THIS PAGE HAS BEEN INTENTIONALLY LEFT BLANK.

4 Replaceable Parts

Introduction	108
Replaceable Parts	109
How To Order A Part	110
Parts Identification	112

Introduction

This chapter contains parts-ordering information for the Keysight 553147A/148A/149A Counter. [Table 4-1](#) lists the reference designations used in the parts list and throughout this guide, [Table 4-2](#) lists all replaceable assemblies and parts. [Figure 4-1](#) is an exploded view of the Keysight 553147A/148A/149A's internal parts, [Figure 4-2](#) is an exploded view of the cabinet and other external parts, and [Figure 4-3](#) is a top view of the chassis with the shroud removed. These illustrations are provided to help you locate and identify parts.

Replaceable Parts

Table 4-2 contains a list of replaceable parts that is organized as follows:

- 1** Electrical assemblies in alphanumeric order by reference designation.
- 2** Chassis-mounted electrical parts in alphanumeric order by reference designation.
- 3** Chassis-mounted mechanical parts in alphanumeric order by reference designation.

The information given for each part consists of the following:

- 1** Reference designation.
- 2** Keysight part number.
- 3** The quantity (QTY) of the part used in the instrument (field-replaceable items only).
- 4** Description of the part.
- 5** Typical manufacturer's part number for the part (when available).

How To Order A Part

Keysight Technologies wants to keep your parts ordering process as simple and efficient as possible. To order parts, perform the following steps:

- 1** Identify the part and the quantity you need.
- 2** Determine the ordering method to be used, and contact Keysight.

If the part you need is *not identified* in this chapter, you can call Keysight for help (see the following section titled “[Contacting Keysight Technologies](#)”). Please have the following information available when you contact Keysight for help:

- Instrument Model Number (example, “Keysight 53148A”).
- Complete instrument Serial Number (example, “1234A56789”). Information about where to find the serial number is provided in the Preface portion of this guide in the section titled “How to Use This Guide.”
- Description of the part(s) and its use.
- Quantity of the part(s) required.

Contacting Keysight Technologies

Depending on where you are in the world, there are one or more ways to obtain parts or parts information from Keysight Technologies contact your local Keysight Technologies sales office.

- Within the United States, we encourage you to order replacement parts or request parts information directly by telephone or mail from Keysight using the telephone numbers or address listed on the next page. You can also contact your local Keysight sales office. Keysight sales offices are listed near the back of this guide.

By Telephone:

- For Parts Ordering, use our toll-free number, **(800) 227-8164**, Monday through Friday (except Holidays), 6:00 a.m. to 5:00 p.m. (Pacific Time).
- For Parts Identification Assistance, call us at **(916) 783-0804**. Our Parts Identification hours are from 6:00 a.m. to 3:00 p.m. (Pacific Time) on Monday through Thursday and from 6:00 a.m. to 2:00 p.m. (Pacific Time) on Friday.

For Mail Correspondence, please use the address below:

Keysight Technologies
P.O. Box 1145
Roseville, CA 95661-1145

Parts Identification

To identify the part(s) you need, refer to the exploded views in [Figure 4-1](#) and [Figure 4-2](#) and the top view of the chassis in [Figure 4-3](#).

When ordering from Keysight Technologies, the important numbers to note from the Parts List are the Keysight Part Number and the quantity of the part(s) you need.

Reference Designations

[Table 4-1](#) lists the reference designations used in the parts lists.

Table 4-1 Reference Designations

A	= assembly	P/O	= part of
H	= hardware	S	= switch
J	= electrical connector (stationary portion); jack	T	= transformer
MP	= miscellaneous mechanical part	TP	= test point
P	= electrical connector (movable portion); plug	U	= integrated circuit; microcircuit
		W	= cable; transmission path; wire

Cabinet Parts and Hardware

To locate and identify cabinet and external parts and mounting hardware, refer to [Figure 4-2](#) (internal parts and mounting hardware are shown in [Figure 4-1](#)). These figures provide different views of the instrument, with the parts identified by reference designations; the reference designations correspond with the ones in [Table 4-2](#).

Accessories and Miscellaneous Items

[Table 4-3](#) lists all of the accessories available for the Counter and also lists some other miscellaneous items, such as power cords, rack mounts, and manuals.

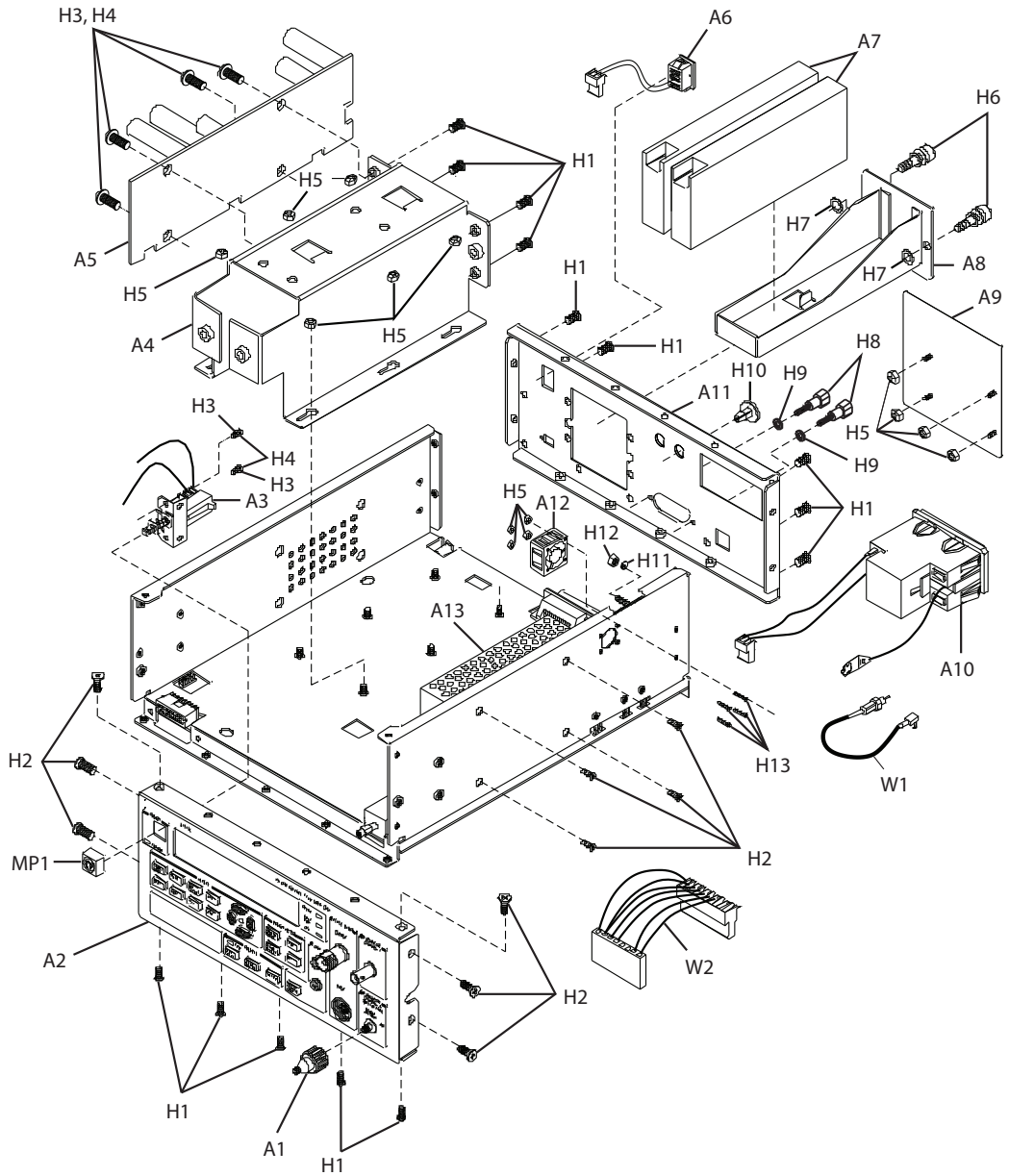

Figure 4-1 Keysight 53147A/148A/149A Exploded View – Internal Parts

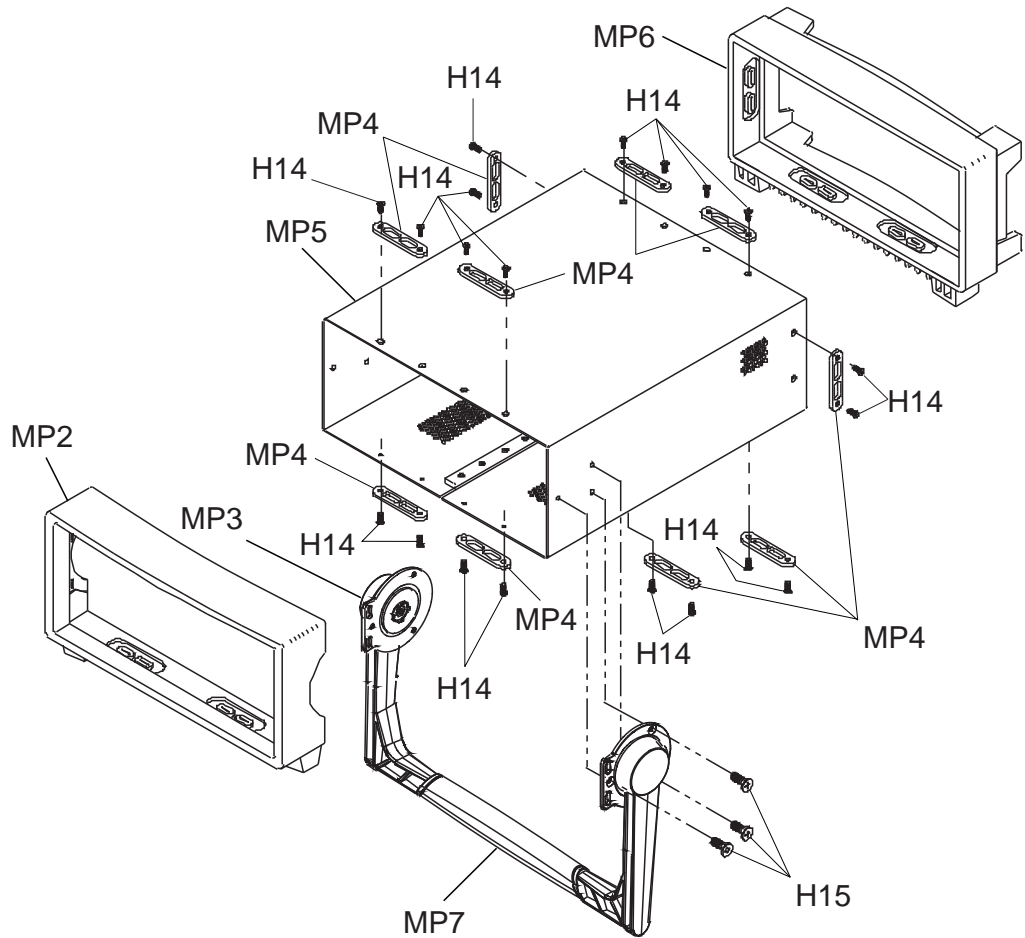

Figure 4-2 Keysight 53147A/148A/149A Exploded View – Cabinet and External Parts

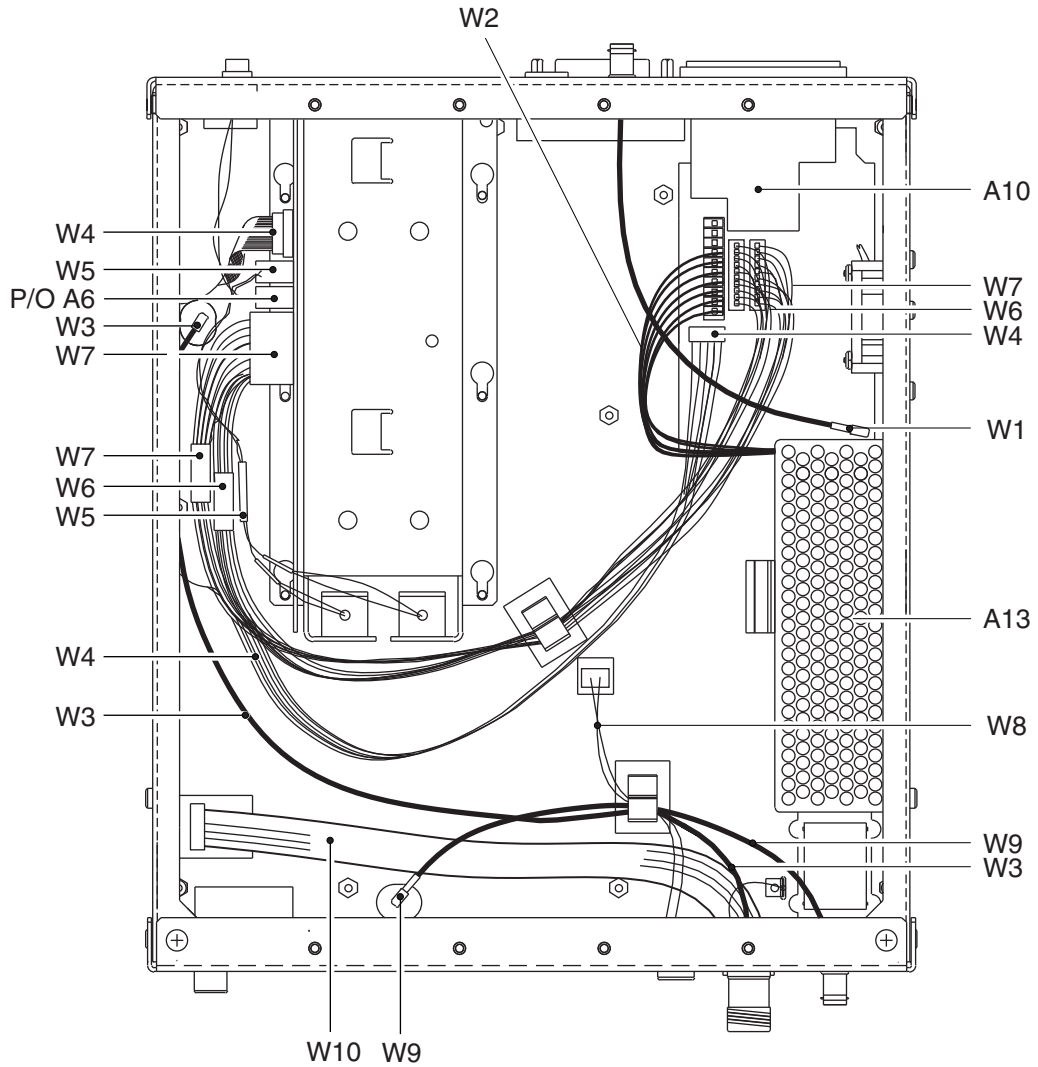

Figure 4-3 Keysight 53147A/148A/149A Top View

Table 4-2 Keysight 53147A/148A/149A Replaceable Parts

Reference Designation	Keysight Part Number	Qty.	Description	Mfr. Part Number
A1	53152-80001	1	ADAPTER, 2.92 mm FEMALE ¹	2610181-00
A2 (53147A)	53147-60207	1	PANEL ASSY, FRONT (53147A)	2011509-01
A2 (53148A)	53148-60207	1	PANEL ASSY, FRONT (53148A)	2011510-01
A2 (53149A)	53149-60207	1	PANEL ASSY, FRONT (53149A)	2011511-01
A3	53147-20203	1	SWITCH ASSY, FRONT PANEL POWER	4540015-00
A4	53150-00002	1	HOUSING ASSY, BATTERY ²	5211156-01
A5	53150-60004	1	DC/DC CONVERTER PCB ²	2020543-04
A6	53147-60223	1	SWITCH ASSY, BATTERY ²	2041107-01
A7	53150-80010	2	BATTERY, LEAD-ACID, RECHARGEABLE ²	5000410-00
A8	53150-00004	1	SLED ASSY, BATTERY ²	5218025-01
A9	53150-00003	1	COVER, BATTERY OPENING ³	5218019-01
A10	53147-40007	1	POWER ENTRY MODULE ASSY.	2011513-01
A11	53147-60219	1	PANEL ASSY, REAR	5218104-01
A12	53147-80012	1	FAN, COOLING	2011514-01
A13	0950-3299	1	POWER SUPPLY ASSY, 45 W	2011156-01
H1	2200-0165	18 ⁴	SCREW, FLATHEAD, SELF-LOCKING, 4-40x1/4	5140004-04
H2	2360-0192	10	SCREW, FLATHEAD, 6-32x1/4	5144006-04
H3	2190-0004	6	WASHER, LOCK, #4 (USE WITH H4)	—
H4	2200-0139	6	SCREW, PANHEAD, 4-40x5/16	5174004-04
H5	0590-0076	10	NUT, HEX, SELF-LOCKING, 4-40 ⁴	5184004-40

¹ 53149A only² With Option 002 only³ Without Option 002⁴ Qty. = 8 without Option 002⁵ Part of A10, in Counters without Option 002, this harness is used in place of W6 and W7.

Table 4-2 Keysight 53147A/148A/149A Replaceable Parts (continued)

Reference Designation	Keysight Part Number	Qty.	Description	Mfr. Part Number
H6	1390-0832	2	SCREW, KNURLED HEAD, CAPTIVE, W/WASHER ²	5110101-00
H7	1390-0473	2	WASHER, RETAINING (USE WITH H6) ²	5000420-00
H8	0380-0643	2	SCREW, HEX STANDOFF, 6-32	–
H9	2190-0007	2	WASHER, LOCK, #6	–
H10	6960-0045	1	HOLE PLUG, REAR PANEL	5000246-00
H11	3050-0010	1	WASHER, FLAT, #6	–
H12	0590-0157	1	NUT, HEX, SELF-LOCKING, 6-32	5000046-00
H13	2200-0155	4	SCREW, PANHEAD, 4-40x1	5120004-16
H14	2200-0143	20	SCREW, FLATHEAD, 4-40x3/8	5174004-04
H15	0515-1101	6	SCREW, TORX, FLATHEAD, m4x8	5138007-01
MP1	53150-40008	1	SWITCH CAP, FRONT PANEL POWER	5230012-00
MP2	53147-40001	1	BUMPER, FRONT	5230016-01
MP3	53147-40005	2	MOUNT, HANDLE	5230015-01
MP4	53147-40010	10	RETAINER, BUMPER	5230018-01
MP5	53147-00001	1	SHROUD	5218106-01
MP6	53147-40002	1	BUMPER, REAR	5230017-01
MP7	53147-40013	1	HANDLE ASSY.	2011508-01
MP8	53147-40011	1	JACK, BANANA, RED, DVM INPUT	2640038-01
MP9	53147-40012	1	JACK, BANANA, BLACK, DVM INPUT	2640039-01
W1	53150-60210	1	CABLE ASSY, COAXIAL, 10 MHz I/O	2041086-02
W2	53147-60224	1	CABLE ASSY, HARNESS, OUTPUT, DC SUPPLY	2041083-01

¹ 53149A only² With Option 002 only³ Without Option 002⁴ Qty. = 8 without Option 002⁵ Part of A10, in Counters without Option 002, this harness is used in place of W6 and W7.

Table 4-2 Keysight 53147A/148A/149A Replaceable Parts (continued)

Reference Designation	Keysight Part Number	Qty.	Description	Mfr. Part Number
W3	53147-60221	1	CABLE ASSY, COAXIAL, OUTPUT, POWER REFERENCE	5450030-01
W4	53150-60213	1	CABLE ASSY, RIBBON, STATUS INTERFACE ²	2041092-01
W5	53150-60208	1	CABLE ASSY, HARNESS, INTERCONNECT, BATTERY ²	2041088-01
W6	53150-60212	1	CABLE ASSY, HARNESS, RETURN ²	2041087-02
W7	53150-60211	1	CABLE ASSY, HARNESS, INTERCONNECT ²	2041087-01
–	–	1	CABLE ASSY, HARNESS, INTERCONNECT ⁵	2041082-01
W8	53147-60222	1	CABLE ASSY, HARNESS, INPUT, DVM	2041108-01
W9	53150-60216	1	CABLE ASSY, COAXIAL, INPUT, BAND 1	2041086-01
W10	53147-60220	1	CABLE ASSY, RIBBON, INPUT, POWER METER	5450031-01

¹ 53149A only

² With Option 002 only

³ Without Option 002

⁴ Qty. = 8 without Option 002

⁵ Part of A10, in Counters without Option 002, this harness is used in place of W6 and W7.

Table 4-3 Keysight 53147A/148A/149A Accessories and Miscellaneous Items

Description	Keysight Part Number
BATTERY 12 V	53150-80010
CABLE ASSY, EXT. DC POWER	53150-60214
GPIB CABLES	10833A/B/C/D
TEST LEAD KIT, DVM	34132-37904
CABLE ASSY, POWER (AUSTRALIA)	8120-0696
CABLE ASSY, POWER (CANADA)	8120-1692
CABLE ASSY, POWER (DENMARK)	8120-2957
CABLE ASSY, POWER (ENGLAND)	8120-1703
CABLE ASSY, POWER (GERMANY)	8120-2296
CABLE ASSY, POWER (JAPAN)	8120-4754
CABLE ASSY, POWER (S. AFRICA)	8120-4600
CABLE ASSY, POWER (USA)	8120-1521
CABLE ASSY, RS-232, DB-25/RJ-12	53150-60215
CARRYING CASE, SOFT	53147-80016
CHARGER, BATTERY, 115 V (INCLUDES AUTOMOTIVE POWER ADAPTER)	53150-60217
CHARGER, BATTERY, 230 V (INCLUDES AUTOMOTIVE POWER ADAPTER)	53150-60218
FUSE 1.0 A 250 V TD	2110-0007
GUIDE, OPERATING AND PROGRAMMING	53147-90009
GUIDE, ASSEMBLY-LEVEL SERVICE	53147-90010
RACK MOUNT KIT	53147-67001

THIS PAGE HAS BEEN INTENTIONALLY LEFT BLANK.

5 Backdating

Introduction [122](#)

Introduction

As of the current edition of this guide (Edition 3, November 1, 2017), this chapter does not contain any information for adapting this guide to apply to older instruments.

As engineering changes are made, newer instruments may have higher serial prefix numbers than the ones shown on the title page of this guide. These instruments may be supplied with a *Manual Updating Changes* package containing the required information, or they may be supplied with newer editions of this guide that contain information about adapting that edition of this guide to older instruments.

If a *Manual Updating Changes* package is included with your Counter, modify existing guide information or replace the affected pages as directed in the pages of the *Manual Updating Changes* package. For additional information, contact the nearest Keysight Sales and Support Office.

6 Specifications

For the specifications and characteristics of the 53147A/148A/149A Microwave Frequency Counter/Power Meter/DVM, refer to the datasheet at <http://literature.cdn.keysight.com/litweb/pdf/5988-0300EN.pdf>

THIS PAGE HAS BEEN INTENTIONALLY LEFT BLANK.

A Rack Mounting the Instrument

Rack Mounting the Instrument [126](#)

Rack Mounting the Instrument

You can mount the Keysight 53147A, 53148A, and 53149A in a standard 19-inch rack using the optional Rack Mounting Kit (53147-67001) available from Keysight:

To rack-mount the instrument, you must first remove the front bumper, the front bumper retainers, and the carrying handle. Use the following procedure to prepare the instrument for rack-mounting:

NOTE

Unlike the hardware used elsewhere in this instrument, all hardware used to attach the handle pivots and the rack mounts to the instrument is metric.

- 1 Remove the front bumper by lifting the inner edge of the bumper away from the shroud near one corner at the top and one side and pulling that corner away from the instrument. Repeat the process with the remaining corners until the bumper is free of the instrument.

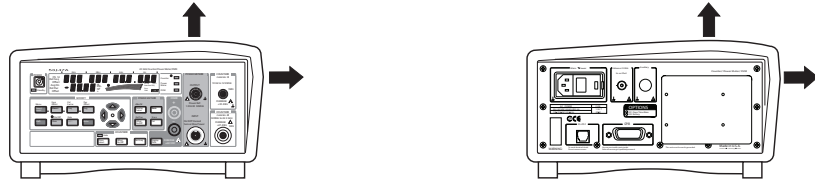

- 2 Pull out on both sides of the handle at the handle pivots, and rotate the handle towards the top of the instrument until the handle is touching the top of the shroud.
- 3 Use a T15 Torx™ tool to remove the three screws that attach each of the handle pivots to the sides of the instrument, and remove the handle.
- 4 Use a #1 Phillips™ screwdriver to remove the two screws that attach each of the front bumper retainers to the top and bottom of the instrument (there are four front bumper retainers—two each on the top and bottom).

- 5 Position the rack-mount panel (53147-60211) on the front of the instrument so that the four holes in the top and bottom of the rack-mount panel are aligned with the four threaded holes in the top and bottom of the instrument (the holes that were used to mount the front bumper retainers).

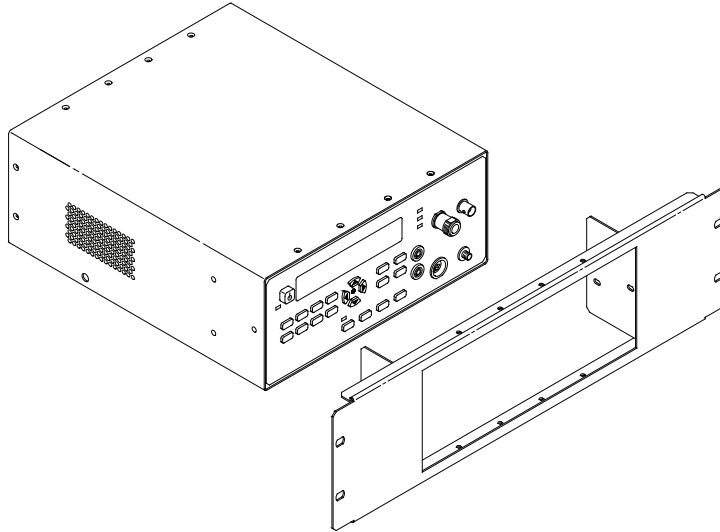

A Rack Mounting the Instrument

- 6 Insert the eight 3/8-inch x 4-40, pan-head Phillips screws (2) supplied in the Rack Mount Kit through the holes in the top and bottom of the rack-mount panel into the threaded holes in the top and bottom of the instrument. Start the screws, but do not tighten them at this time.

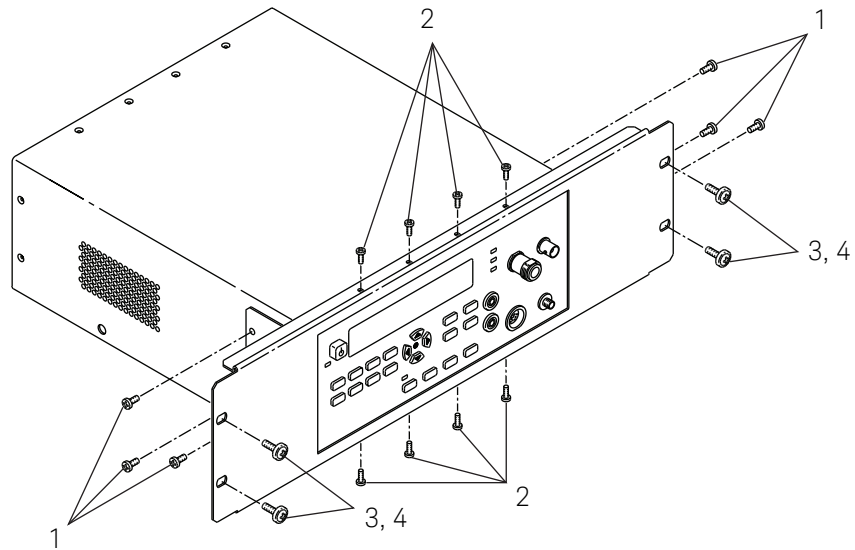

- 7 Insert the six 10mm long, 4 mm x .7, pan-head Torx screws (1) supplied in the Rack Mount Kit through the holes in the side flanges of the rack-mount panel and tighten them fully.
- 8 Tighten the eight screws you inserted in Step 6.

NOTE

You can use angle brackets to help support the instrument in the rack and to make it easier to mount the instrument.

- 9 Place the four Nylon washers supplied in the Rack Mount Kit over the four 10-32 screws (3, 4).
- 10 Inspect the holes in the rack to determine if they are threaded. If the holes are threaded, skip Step 11.

- 11** Insert the four sheet-metal U-nuts provided in the Rack Mount Kit in the rack flange behind the four holes you intend to use to mount the instrument.
- 12** While holding the instrument in position in the rack, insert one of the 10-32 screws with the Nylon washer on it (3,4) through one of the upper holes in the rack-mount panel into the threaded hole in the rack (or into the U-nut you installed in Step 11 if the hole is not threaded).
- 13** Repeat the procedure in Step 12 for the remaining upper rack-mount hole and the two lower rack-mount holes.
- 14** Tighten all four rack-mount screws.
- 15** Connect the power cord to the **Main ~ Power** input connector on the instrument's rear panel.
- 16** Connect the other end of the power cord to an appropriate AC power source.

A Rack Mounting the Instrument

THIS PAGE HAS BEEN INTENTIONALLY LEFT BLANK.

Index

Symbols

+5 VDC, [82](#)

Numerics

10 MHz Timebase Calibration, [60](#)
22 GHz to 26.5 GHz Frequency Sensitivity, [37](#)
30 GHz to 46 GHz Frequency Sensitivity, [38](#)
50 MHz to 125 MHz Frequency Sensitivity, [33](#)
50 MHz to 20 GHz Frequency Sensitivity, [35](#)

A

Accessories, [119](#)
Accessories and Miscellaneous Items, [112](#)
address, [111](#)
adjusting the +5 VDC output, [82](#)
Assemblies, [89](#)
assemblies, [90, 108](#)
Assembly Identification, [79](#)

B

Bumpers, [93](#)

C

Cabinet, [114](#)
cabinet, [108](#)
Cabinet Parts and Hardware, [112](#)
calibration, [19, 59](#)
calibration procedure, [59](#)
Calibration Procedures, [59](#)
calibration procedures, [59](#)
Channel 1 Frequency Sensitivity, [31](#)
Complete Performance Tests, [18, 30](#)

Contacting Keysight Technologies, [111](#)
Cooling Fan, [103](#)
correspondence, [111](#)

D

DC Power Supply Assembly, [81](#)

E

electrostatic discharge, [77](#)
Emergency Response, [57](#)
equipment, [77](#)
Equipment Required, [20, 59](#)
Error Messages, [83, 85](#)
-12V FAIL, [85, 86](#)
12V FAIL, [85, 86](#)
-5V FAIL, [85, 86](#)
ADC FAIL, [85, 86](#)
EEP WRT FAIL, [85](#)
FPANEL FAIL, [85](#)
FPGA FAIL, [85, 86](#)
 GPIB FAIL, [85, 86](#)
HET PATH FAIL, [85](#)
IIC FAIL, [85, 86](#)
INSTCFG FAIL, [85, 86](#)
OVERTEMP, [85](#)
PATH FAIL, [85](#)
PWR CAL FAIL, [85, 86](#)
PWR CKT FAIL, [85](#)
RAM FAIL, [85, 86](#)
SAV SET FAIL, [85, 86](#)
SERVICE FAIL, [85, 86](#)
THRS FAIL, [85](#)
THRS HET, [85](#)
THRS THRU, [85](#)
THRU FAIL, [85](#)
VCO/CNT FAIL, [85](#)
Exploded View, [113, 114](#)
exploded view, [108](#)
exploded views, [112](#)
Express Calibration Service, [57](#)
external parts, [108](#)
External Timebase Tests, [24](#)

F

fan, [22](#)
Frequency Sensitivity, [31, 33, 35, 37, 38, 51, 52](#)
Front Panel at a Glance, [18](#)

H

Handle, [94](#)
How To Order A Part, [110](#)

I

Instrument Service Division, [57](#)
Internal Parts, [113](#)
internal parts, [108](#)
ISD, [57](#)

M

Manual Updating Changes, [122](#)
Messages, [86](#)
messages, [83, 84](#)
Miscellaneous Items, [119](#)

O

Operational Verification, [18, 51](#)
ordering parts, [110](#)

P

Packing the Counter in Commercially Available Packaging Materials, [58](#)
Packing the Counter in the Original Packaging Materials, [58](#)
Parts, [107, 113, 114, 116](#)
Parts Identification Assistance, [111](#)
Parts Ordering, [111](#)
parts ordering, [110](#)
parts-ordering information, [108](#)
Performance Test Record, [19, 51](#)

performance test record, [51](#), [52](#), [53](#)
Power Measurement, [39](#)
power reference oscillator, [59](#)
Power Supply Assembly, [81](#)

R

Rack Mounting the Counter, [126](#)
Rear Panel Assembly, [101](#)
Recommended Calibration Cycle, [19](#)
reference designations, [108](#)
Removing the Bumpers, [93](#)
Removing the Cooling Fan, [103](#)
Removing the Cover, [96](#)
Removing the Handle and the Handle Mounts, [95](#)
Removing the Rear Panel Assembly, [98](#)
Removing the Shroud, [96](#)
replaceable assemblies, [108](#)
Replaceable Parts, [107](#), [116](#)
replaceable parts, [109](#)
Replacing Assemblies, [89](#)
required equipment, [20](#), [59](#)
Returning the Counter for Service, [57](#)
Returning the Counter to Keysight Technologies for Service, [57](#)
RS-232, [83](#), [84](#)

S

safety, [76](#)
Self-Test, [83](#)
Serial Number, [110](#)
service, [55](#)
Shroud, [96](#)
specifications, [30](#)
Standby mode, [22](#)
surface-mount components, [77](#)

T

Test 1
Channel 1 Frequency
Sensitivity, [31](#)

Test 1a
10 Hz to 20 MHz Frequency
Sensitivity, [31](#)
Test 1b
50 MHz to 125 MHz Frequency
Sensitivity, [33](#)
Test 2
Channel 2 Frequency
Sensitivity, [35](#)
Test 2a
50 MHz to 20 GHz Frequency
Sensitivity, [35](#)
Test 2b
22 GHz to 26.5 GHz Frequency
Sensitivity, [37](#)
Test 2c
30 GHz to 46 GHz Frequency
Sensitivity, [38](#)
Test 3
Channel 2 Power
Measurement, [39](#)
test equipment, [77](#)
test record, [51](#), [52](#), [53](#)
timebase, [22](#), [59](#)
toll-free number, [111](#)
Tools, [91](#)
Tools Required, [91](#)
Top View, [115](#)
top view, [108](#)
troubleshooting, [76](#), [81](#)
Troubleshooting the Counter, [81](#)

W

warranty, [77](#)



This information is subject to change without notice. Always refer to the Keysight website for the latest revision.

© Keysight Technologies 2001 - 2017
Edition 3, November 1, 2017

Printed in Malaysia



53147-90010

www.keysight.com

