



Agilent 5071A Primary Frequency Standard

Operating and Programming Manual



Agilent Technologies

Operating and Programming Manual

SERIAL NUMBER PREFIX: US3930

(See Instruments Covered by this Manual, in the Introduction for information about manual applicability and your instrument.)

**Agilent 5071A Primary
Frequency Standard**

©Copyright Agilent Technologies, Inc. 1992 - 2000

All Rights Reserved. Reproduction, adaptation, or translations without prior written permission is prohibited, except as allowed under the copyright laws.

Printed: December 2000

Printed in USA

**Manual part number
05071-90041**

Certification and Warranty

Certification

Agilent Technologies certifies that this product met its published specification at the time of shipment from the factory. Agilent further certifies that its calibration measurements are traceable to the United States National Institute of Standards and Technology (formerly National Bureau of Standards), to the extent allowed by the Institute's calibration facility, and to the calibration facilities of other International Standards Organization members.

Warranty

Agilent warrants Agilent hardware, accessories and supplies against defects in materials and workmanship for a period of one year from date of shipment. If Agilent receives notice of such defects during the warranty period, Agilent will, at its option, either repair or replace products which prove to be defective. Replacement products may be either new or like-new.

Agilent warrants that Agilent software will not fail to execute its programming instructions, for the period specified above, due to defects in material and workmanship when properly installed and used. If Agilent receives notice of such defects during the warranty period, Agilent will replace software media which does not execute its programming instructions due to such defects.

For detailed warranty information, see back matter.

Safety Considerations General

This product and related documentation must be reviewed for familiarization with this safety markings and instructions before operation.

This product is a safety Class I instrument (provided with a protective earth terminal).

Before Applying Power

Verify that the product is set to match the available line voltage and the correct fuse is installed. Refer to instructions in Chapter 1 of the Manual.

Before Cleaning

Disconnect the product from operating power before cleaning.

Safety Earth Ground

An uninterruptible safety earth ground must be provided from the mains power source to the product input wiring terminals or supplied power cable.

Warning Symbols That May Be Used In This Book



Instruction manual symbol; the product will be marked with this symbol when it is necessary for the user to refer to the instruction manual.



Indicates hazardous voltages.

Safety Considerations (contd)



Indicates earth (ground) terminal.



or



Indicates terminal is connected to chassis when such connection is not apparent.



Indicates Alternating current.



Indicates Direct current.

WARNING _____
BODILY INJURY OR DEATH MAY RESULT FROM FAILURE TO HEED A WARNING. DO NOT PROCEED BEYOND A WARNING SIGN UNTIL THE INDICATED CONDITIONS ARE FULLY UNDERSTOOD AND MET.

CAUTION _____
Damage to equipment, or incorrect measurement data, may result from failure to heed a caution. Do not proceed beyond a *CAUTION* sign until the indicated conditions are fully understood and met.

For additional safety and acoustic noise information, see back matter.

MANUAL UPDATING COVERAGE	MANUAL IDENTIFICATION
This supplement adapts your manual to Serial Numbers prefixed through: US3930	Instrument: Agilent 5071A Primary Frequency Standard Operating and Programming Manual Manual Print Date: December 2000 Manual Part Number: 05071-90041

ABOUT THIS SUPPLEMENT

The information in this supplement is provided to correct manual errors and to adapt the manual to instruments containing changes after the manual print date.

Change and correction information in this supplement is itemized by page numbers corresponding to the original manual pages. The pages in this supplement are organized in numerical order by manual page number.

HOW TO USE THIS SUPPLEMENT

Insert this title page in front of the title page in your manual.

Perform all changes specified for “All Serials”, and all changes through the Series Prefix of your instrument or board.

Insert any complete replacement pages provided into your manual in the proper location. The following pages are included in this update:

If your manual has been updated according to the last edition of this supplement, you need only perform those changes pertaining to the new series prefix; see List of Effective Pages. New information affecting “All Serials” will be indicated by a “#” in front of the change.



LIST OF EFFECTIVE PAGES

SERIAL PREFIX, SERIAL # OR DATE CODE	PAGES
---	-------

All Serials 3-5, 4-23

MANUAL CHANGES, AGILENT 5071A OPERATING AND PROGRAMMING MANUAL

SERIAL PREFIX, SERIAL # OR DATE CODE	CHANGES
---	---------

PAGE 3-5, Instrument States

All Serials >Change item **4. Warning** to read:

4. **Warning:** The Yellow Attention light flashes while the Continuous Operation light remains ON. This continues as long as the warning condition exists. The instrument will return to Normal operation and the Attention light will stop flashing if the Warning condition clears. A message describing the cause on the warning may be read from the instrument's front panel via the LOG menu choice.

PAGE 4-23, Printer-Mode Output

All Serials >Change the **Note** to read:

These "unprompted" messages may be inconvenient when the instrument is controlled by a computer and can be suppressed with the DIAG:LOG:VERB DISABLE command line.

The messages can then be obtained from the instrument's non-volatile log on demand.

Contents

Preface

Introducing the 5071A	xii
Operating The 5071A	xiv
How this Manual is Organized	xviii
Manuals Supplied	xix
Related Documentation	xix
Accessories, Options, and Specifications	xix
Instruments Covered by This Manual	xx
Suggested Sequence of Reading	xx

1 Getting Started

The 5071A at a Glance	1-2
Indicators	1-2
Controls	1-2
Connectors	1-2
Quick Reference Guide to Controls	1-2
Rear-Panel Connections	1-5
Starting the 5071A	1-6
Performing Basic Tasks	1-8
Synchronizing to an External 1 PPS Reference	1-8
Setting Time and Date	1-9
To Set Time	1-9
To Set Date	1-9
Powering Down the 5071A	1-9

2 Using the 5071A

Chapter Contents	2-2
Using the Front-Panel Menus	2-4
Keypad Descriptions	2-4
ACTIONS Keypad	2-4
DATA ENTRY / FUNCTION Keypad	2-4
Action Key Functions	2-4
Controlling the 5071A From the Front-Panel	2-5
Setting the Output Port Frequency	2-5
Setting the 1pps and Clock Outputs	2-6
To Set the 1pps Outputs	2-6
To Synchronize the 1pps Outputs Using a Time-Interval Counter	2-6
To Set the Clock	2-7

Setting the Time	2-7
To Turn the Clock Display On or Off	2-8
To Schedule a Leap Second	2-9
Monitoring Status	2-10
To Select Parameters	2-10
To Interpret Displayed Results	2-10
To Print a Status Report	2-10
Reading and Managing the Event Log	2-11
To Check Log Status	2-11
To View Log Entries	2-11
To Clear the Log	2-11
To Print the Log	2-11
Steering the Output Frequency	2-12
Steering Explained	2-12
To Add an Offset	2-12
To Check an Offset	2-13
To Remove an Offset	2-13
Using Utility Features	2-14
To Reset the Continuous Operation Light	2-14
To Reset the Rear-Panel Status Output	2-14
To Display the Firmware Revision or CBT Identification String	2-14
Diagnostic Self-Tests	2-14
Configuring the 5071A	2-15
To Set the Operating Mode	2-15
To Set the Printer Log Mode	2-15
To Set Up the Serial Port	2-16
To Save a Configuration	2-16
Connecting a Printer	2-16
Disabling the Internal Standby Battery	2-17
3 In Case of Difficulty	
Chapter Contents	3-2
Front-Panel Indicators and Messages	3-3
Clock Display	3-3
Attention Light	3-3
Continuous Operation Light	3-3
LCD Display	3-4
Instrument States	3-5
Front-Panel Warning Messages	3-6
Remote Mode	3-6
Standby Mode	3-6

- Steered Operation 3-6
- Power-up Problems 3-7**
- Using Menus to Check Operational Status 3-8**
 - INFORmation Menu 3-8
 - LOG Menu 3-8
 - UTILities Menu 3-8
 - CLOCK Menu 3-8
 - CONFIGuration Menu 3-8
- Operating System Failure 3-9**
 - Operating System Failure Symptoms 3-9
 - Restarting the 5071A 3-9
- Verifying Operation 3-10**
- Cesium Beam Tube Life 3-10**
- 4 Remote Operation and Programming**
 - Chapter Contents 4-2**
 - Remote-Operation Setup 4-3**
 - Overview 4-3
 - Remote Interface Features 4-3
 - Serial-Port Description 4-3
 - Hardware Connection 4-4
 - Serial-Port Configuration 4-6
 - Remote-Modem Setup and Precautions 4-8**
 - Overview 4-8
 - Modem Selection 4-8
 - Modem Configuration 4-8
 - Verifying Remote Operation with a Terminal 4-9
 - Programming Overview 4-10**
 - SCPI Command Conformance 4-11**
 - Command Types 4-12**
 - Common Command Format 4-12
 - SCPI Command and Query Format 4-12
 - Command Separator 4-12
 - Abbreviated Commands 4-13
 - Implied Channel 4-13
 - Implied Commands 4-13
 - Parameter Types 4-14
 - Optional Parameters 4-15
 - Query Parameters 4-15
 - Linking Commands 4-15
 - *RST Reset Response 4-16

Sample Program Commands	4-17
Status Monitoring Tasks	4-18
Example Program 1 — Status Report Inquiry	4-18
Example Program 2 — Print Log Request	4-18
Instrument Control Tasks	4-19
Example Program 1 — Configuration	4-19
Example Program 2 — Synchronization and Time/Date Setup	4-19
Example Program 3 — Leap Second Insertion	4-20
Example Program 4 — Steering the Outputs	4-20
Example Program 5 — Slewing the Clock	4-20
Batch Processing for the Program Commands	4-21
Command Scripts On a Personal Computer	4-21
SCPI Considerations For HP BASIC	4-22
SCPI on RS-232C	4-22
Full-Duplex Communication	4-22
Printer-Mode Output	4-23
Example Program	4-24
Tips on Using the RS-232C Port on the 5071A	4-27
Keypad Lock-Ups: Why do they occur and how are they cleared?	4-27
Description	4-27
XON/XOFF	4-27
DSR	4-28
Using Ctrl-Q in Programs	4-29

5 Command Reference

Chapter Contents	5-2
5071A Command Summary	5-3
IEEE 488.2 Common Commands	5-3
SCPI Commands	5-5
Description of SCPI Commands	5-9
Diagnostic Commands	5-9
Display Commands	5-14
Precision Time (Date and Time) Commands	5-15
Reference Oscillator Commands	5-19
STATus Monitoring Commands	5-21
Parameter Entry	5-21
Using the Operation Status Register	5-21
Using the Questionable Data Register	5-24
System Commands	5-26

Status Reporting 5-30

Rear-Panel Status Output Operation 5-33

Status Output Programming 5-33

Example 1 — Programming the Status Output for a Single True Condition 5-34

Example 2 — Programming the Status Output for Multiple True and False Conditions 5-34

Serial-Port Command/Printer Interface 5-35

Mode Selection 5-35

Pacing 5-35

The Prompt 5-36

End-Of-Line Characters 5-36

Error Messages/Codes 5-37

6 Specifications

Introduction 6-2

Chapter Summary 6-2

Accuracy and Stability 6-3

Frequency stability (5- and 10-MHz outputs) 6-4

Sinusoidal output characteristics (all located on rear panel) 6-4

Supplemental Characteristics † 6-5

Supplemental Characteristics † (continued) 6-6

Telecommunications Options 6-7

Footnotes: 6-7

7 Installation

Chapter Contents 8-2

Initial Inspection 8-3

Preparation for Use 8-4

Power Requirements 8-4

Selecting Line Voltage and Fuse 8-5

AC Power Cabling 8-6

Operating Environment 8-7

Bench Operation 8-7

Installing Options 908 and 913 8-7

Returning the 5071A to Agilent 8-8

Operator's Maintenance 8-11

Operating the 5071A From External-DC Power 8-11

Preparing the 5071A For External-DC Operation 8-11

Replacing the External DC Input Power Fuse 8-12

- Internal Standby Battery Maintenance 8-13**
 - Battery Shelf Life and Storage 8-13
 - Battery Operating Temperatures 8-13
 - Battery Charging 8-14
 - Battery Disposal 8-15
 - Using the Battery Disconnect Switch 8-15
 - Removing and Replacing the Internal Battery 8-16
- Cesium Beam Tube Replacement 8-17**
- Long-Term Storage 8-17**

A Performance Tests

- Introduction A-2**
 - Operational Verification A-2
 - Complete Performance Tests A-2
 - RS-232 Verification A-2
- Test Record A-2**
- Equipment Required A-3**
- 5071A Operational Verification A-6**
 - Power-On Self-Tests and Servo Lock A-6
- Rear-Panel Output Signal Checks A-8**
 - Required Equipment A-8
- RS-232 Serial Port Verification A-9**
- 5071A Complete Performance Tests A-11**
 - Test 1— Output Signals: Harmonic Distortion and Spurious Signals Check A-11
 - A. Harmonic Distortion Check for the 5 and 10 MHz Outputs A-11
 - B. Non-Harmonic (Spurious) Signal Check for the 5 and 10 MHz Outputs A-13
 - C. Harmonic Distortion Check for the 1 MHz Output A-15
 - D. Harmonic Distortion Check for the 100 kHz Output A-17
 - Test 2 — Frequency Accuracy A-19
 - Equipment A-19
 - Setup A-19
 - Specifications A-20
 - Procedure A-20
 - Test 3 — Stability A-22
 - A. Time Domain A-22
 - B. Frequency Domain A-22
- 5071A PERFORMANCE TEST A-23**

B Glossary

5071A Glossary B-2

Index

Contents

Preface

This preface consists of the following:

- **Introducing the 5071A** page -xii
- **Operating The 5071A** page -xiv
- **How this Manual is Organized** page -xviii
- **Manuals Supplied** page -xix
- **Related Documentation** page -xix
- **Accessories, Options, and Specifications** page -xix
- **Instruments Covered by This Manual** page -xx
- **Suggested Sequence of Reading** page -xx

Introducing the 5071A

Overview This introduction describes the 5071A's features, providing information to better understand them so you can operate the instrument effectively. The following is a functional narrative description. For specific details such as signal levels, accuracy, stability, etc., see the specifications in Chapter 6.

What is the 5071A Primary Frequency Standard? The 5071A is a source of extremely accurate and stable output frequencies. The accuracy of the 5071A is within a few parts in 10^{12} of the internationally accepted definition of frequency. This accuracy is made more usable and practical by the 5071A's excellent environmental stability.

How Does the 5071A Work? The 5071A uses a fundamental property of the element cesium to define frequency. Inside the cesium beam tube assembly, an applied microwave signal causes energy-level transitions to occur in the cesium atoms. The microwave signal is synthesized from a 10 MHz Voltage-Controlled Crystal Oscillator (VCXO).

Patented *Cesium II circuit and software technology* detects departures of the microwave frequency from the cesium energy-level transition frequency and corrects them by tuning the VCXO to run precisely at the proper rational-fraction of the cesium frequency. The microprocessor (an integral part of this servo loop) performs the error determination and correction several times a second to ensure that the VCXO is always closely locked to the cesium-transition frequency.

Many functions within the 5071A are under *Cesium II software* control. The software manages the initial warm-up and alignment, then continuously monitors the appropriate signals using this information to control all key operating parameters for optimum performance. Starting the 5071A merely requires connecting ac or dc power (see page 1-6).

After a typical warm-up time of 15 minutes, the standard is fully operational and the operator may optionally press three keys to display a continuous operation signal. There are no maintenance procedures or adjustments needed even when necessary to replace the cesium beam tube. The 5071A meets all specifications within 30 minutes of power connection at room temperature.

- 5071A Major Features
- 5 or 10 MHz programmable outputs
 - Time and date clocks
 - Easily synchronized 1 Pulse Per Second (1PPS) outputs
 - 45-minute standby battery
 - Accurate and precise output frequency steering
 - Event log

System Applications

As a system component, the 5071A's function is significantly enhanced by its capacity for complete remote control via an RS-232C port on the rear panel. All front-panel functions can be programmed through the port as well as many functions not available via the front panel controls. The RS-232C port allows the instrument to:

- Print status reports and internal parameters to an external printer,
- Communicate with and be controlled by a data terminal or computer,
- Communicate over a telephone line or data link via modem.

Operating The 5071A

Local operation of the 5071A is performed on the control panel located behind the front panel door. Here you will find the 5071A's controls and Liquid Crystal Display (LCD). The LCD is backlit for better visibility whenever any key is pressed.

Signal Outputs There are four sinusoidal outputs available on the 5071A: two fixed frequency outputs of 1 MHz and 100 kHz, and two programmable output ports. Each programmable output port can be set to emit a 5 or 10 MHz signal. These two ports are isolated from each other so that noise or impedance changes on one port can not significantly effect the amplitude or phase of the signal on the other port. An additional property of these outputs is that they are phase consistent. That is, when the frequency on a port is changed then returned to the original frequency, the original phase is restored.

Clock Functions The clock functions use the large six-digit LED display, the 1pps outputs, and their control circuits. The 1pps outputs are movable in time and can be automatically synchronized with other 1PPS sources. Clock adjustment procedures can be found in Chapter 2.

Clock display: On power up, the clock display is OFF so the clock will not display incorrect time. The display may be set and turned on using the front-panel controls or the RS-232C interface. If you plan to use the Modified Julian Day (MJD) date system, the time should be set to Coordinated Universal Time (UTC). See below for more information about the MJD.

1pps outputs: There are three 1pps outputs on the 5071A, one on the front panel and two on the rear panel. All are synchronous (pulses occur at the same time) and isolated from each other so that a short circuit or other disturbance on one, can not effect the amplitude or timing on the others.

All 1pps outputs are TTL compatible and are designed for 50 Ω termination. You can automatically synchronize the 1PPS signals to an external 1PPS, or manually change their timing by up to ± 500 ms in 50 ns steps. For automatic sync, there are two reference inputs: one on the front panel and one on the rear panel. You select either input using the front-panel controls.

Leap second: The 5071A can be easily set to add or delete a leap second on a designated day. The leap second is automatically added-to or subtracted-from the last minute of the day. There is no need for operator intervention when the actual leap-second alteration occurs.

Modified Julian Day (MJD): The Modified Julian Day is a number which is unique for each day. This numbering system is widely used by astronomers and scientists to tag data and events. Within the 5071A the MJD is used for two purposes:

- To tag events kept in the instrument's event log, and
- To program the insertion or deletion of a leap second at a future date

The MJD increments at 00:00:00 hours Coordinated Universal time (UTC). To ensure proper synchronization of your MJD setting, the clock display must be set to UTC. If the MJD is not set, the 5071A will start with 00000 in its MJD counter, and increment from there each time the clock display passes 00:00:00 hours. See Chapter 2 for information on how to determine and set the current MJD.

Steering (or offsetting) the 5071A output frequency: The 5071A output frequency can be steered in a very precise and calibrated manner. When steered, the stability of the output signals is identical to the un-steered signal.

You can steer the 5071A over a range of ± 1 part in 10^9 with a resolution of 6.331991 parts in 10^{15} . These specifications are called the SETTABILITY of the 5071A.

Steering is accomplished by changing the ratio between the VCXO output frequency and the cesium transition frequency through a digital synthesizer. The reference frequency of the cesium beam tube is not disturbed. This system has the following advantages over previous HP cesium beam frequency standards:

- No change in stability of steered output over un-steered output,
- Offset from un-steered frequency is precisely known,
- Fast change to the precise steered frequency, and
- Fast and precise return to the original frequency.

As a result of knowing the exact amount that the 5071A has been steered, its value as an independent frequency source in an ensemble is maintained.

Event Log: The event log automatically stores significant events such as power supply changes, system warnings, and error messages. The event log has the following features:

- Non-volatile memory: all data remains if power is lost,
- Stores 190 events,
- Each logged event is time-and-date tagged, and the
- Log may be read locally or via the RS-232C port.

Power input and management: The 5071A operates from either ac- or dc-power. An internal-standby battery provides at least 45 minutes of operating power. Power-source priority is controlled by the 5071A. The priority order is:

1. AC-line power: when below the specified minimum voltage or if absent, the 5071A switches to,
2. External-dc power: if this fails or goes below 22 Vdc, the 5071A switches to,
3. Internal-Standby battery power.

Remote Operation: The 5071A may be operated completely via remote control. The RS-232C port on the rear panel allows the 5071A to be connected to a printer, a computer, or a data terminal. Using a modem and a telephone line, the 5071A can be connected to these devices anywhere in the world. The 5071A is programmed in a standard language called SCPI (Standard Commands for Programmable Instruments) based on IEEE 488.2.

Status Output: The rear-panel status port gives you an additional option for remote monitoring of the 5071A's operating status. In its default mode the rear-panel Status Output indicates when the Continuous Operation light goes out. You can re-program this output to activate on other combinations of internal events.

The Status Output is TTL with the active state asserted LOW. The status outputs of several 071A's can be connected in parallel (in a wired-OR configuration) to operate a system monitor, or act as a service-request signal for a computer. See Rear-Panel Status Output Operation in Chapter 5 for details.

Operating modes: There are two operating modes: Normal and Standby. The default mode is Normal. The operating mode should never be changed from Normal to Standby except under special circumstances. These are described below. **PLACING THE 5071A IN STANDBY MODE WILL CAUSE A LOSS OF TIME AND FREQUENCY ACCURACY.** (See Caution on page 2-15.)

1. Normal mode: The 5071A always powers up in this mode. Use this mode for all normal operation and timekeeping.
2. Standby mode: The Standby mode is enabled through the Utility menu and is used for two special purposes;
 - Long term storage - Use Standby when the 5071A is stored more than 3 months. (See Long-Term Storage on page 7-17 for more information.)
 - Service - If a failure occurs, diagnostics operate in Standby mode.

Remote operation: The remote state can only be entered via remote command through the RS-232C port. In this state the 5071A operates normally with the front-panel controls locked out: no changes can be made to parameters (like 1PPS delay), and no actions can be taken via the front panel. Status information however, can be read when the front panel is locked. If any disallowed operations are attempted the 5071A beeps and displays a message. Remote operation is indicated on the front-panel display with a small lock symbol on the right-hand side.

We believe you will find the 5071A easier to use, more flexible in adapting to your needs, and significantly more accurate and stable than any cesium standard you have ever owned. Now, if you have not already done so, power up the 5071A (instructions are on page 1-6).

How this Manual is Organized

Table of Contents

Preface (this preface) introduces you to the product and the manual.

Chapter 1 Getting Started —

Provides quick start-up and basic operating information.

Chapter 2 Using the 5071A —

Provides detailed front-panel task procedures.

Chapter 3 In Case of Difficulty —

Gives status, message, and recovery information.

Chapter 4 Remote Operation and Programming —

Gives remote-operating information

Chapter 5 Command Reference —

Gives details of programming commands.

Chapter 6 Specifications —

Provides full performance and environmental data.

Chapter 7 Installation —

Gives details for installation and maintenance.

Appendix A Performance Tests —

Provides procedures that verify the 5071A Primary Frequency Standard operate properly and meet electrical performance specifications. Electrical performance is tested against the specifications listed in Chapter 6, “Specifications,” in this manual.

Appendix B Glossary —

Provides definitions and explanations of terms in Chapter 6, “Specifications.”

Index

Manuals Supplied

Operating and Programming manual (this manual), part number 05071-90041

Related Documentation

1. Beginner's Guide to SCPI: part number - H2325-90001 - Edition July 1990, or Beginner's Guide to SCPI, Barry Eppler, Addison-Wesley Publishing Co. 1991.
2. Standard Commands for Programmable Instruments (SCPI), Version 1991.0, May 1991. Available from: SCPI Consortium, Fred Bode, Executive Director, 8380 Hercules Drive, Suite P3, La Mesa, CA 91942.
3. Characterization of Clocks and Oscillators, NIST Technical Note 1337, March 1990.
4. Application Note 1289, The Science of Timekeeping, Agilent part number 5965-7984E.

Accessories, Options, and Specifications

Information concerning accessories, options, and specifications can be found in Chapter 6, "Specifications."

Instruments Covered by This Manual

This instrument has a two-part serial number in the form 0000A00000 or US00000000 which appears on the serial number plate attached to the rear of the instrument. The first four numerical digits and any letters constitute the serial number prefix and the last 4 significant digits form the suffix. The prefix is the same for all identical instruments. It changes only when a change is made to the instrument. The suffix, however, is assigned sequentially and is different for each instrument. This manual applies directly to instruments having the same serial prefix as listed under SERIAL NUMBER on the title page.

An instrument manufactured after the printing of this manual may have a serial number prefix that is not listed on the title page. These unlisted numbers indicate that the instrument is different from that documented in this manual. The manual for this newer instrument is accompanied by a “Manual Updating Changes” supplement. This supplement contains information that explains how to adapt the manual to the newer instrument.

In addition to change information, the supplement may contain information that corrects errors in the manual. The supplement for this manual is identified with the manual print date and part number, both of which appear on the manual title page. Complimentary copies of the supplement are available from Agilent. For information concerning a serial number prefix that is not listed on the title page or the Manual Updating Changes supplement, contact your nearest Agilent Sales and Support Office.

Suggested Sequence of Reading

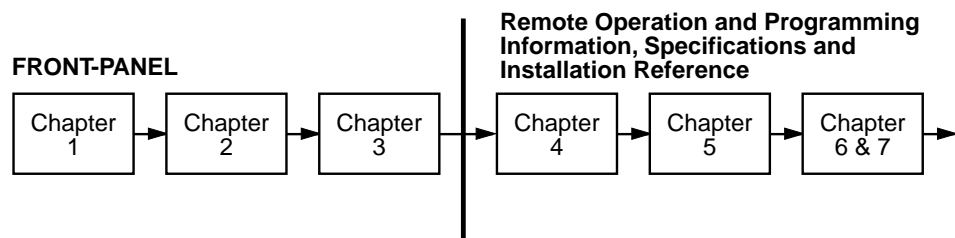

1

Getting Started

- The 5071A at a Glance page 1-2
- Rear-Panel Connections page 1-5
- Starting the 5071A page 1-6
- Performing Basic Tasks page 1-8

The 5071A at a Glance

If you've unpacked and inspected the 5071A and are ready to operate it, go to the top of page 1-6.

The front-panel features are illustrated and briefly described on the following pages. (The item numbers on this page correspond to the callouts in the following Front and Rear panel illustrations).

Indicators

- 1** CLOCK DISPLAY: shows 24-hour time,
- 2** ATTENTION LIGHT: indicates power-up sequence or the need for attention¹
- 3** CONTINUOUS OPERATION LIGHT: when lit continuously, indicates normal operation (No faults since last reset)¹.
- 4** LCD DISPLAY: shows instrument menus, functions, MJD, and internal operating parameters.²

Controls

- 5** DATA ENTRY / FUNCTION KEYPAD: selects six menu shortcuts and enters numeric data.
- 6** ACTIONS KEYPAD: controls Cursor, menu choices, data entry termination, and display contrast.

Connectors

- 7** 1PPS OUTPUT: provides a 20 μ s pulse every second for synchronization and timing.
- 8** SYNC INPUT: accepts a 100 ns to 100 μ s pulse for synchronization of 1 PPS.

(The electrical characteristics of these connectors are the same as the rear-panel 1pps Output and Sync Input. See "Rear-Panel Features" on pages 1-4 and 1-5 for more information.)

Quick Reference Guide to Controls

- 9** QUICK REFERENCE GUIDE TO CONTROLS: explains both the user interface and control/data key actions.

You can use the menu map shown on the next page to customize the 5071A's operation for your time-keeping needs.

¹ Refer to Chapter 3, "In Case of Difficulty," for more information.

² See top of page 1-8 to adjust the LCD display for best viewing.

Chapter 1 Getting Started

The 5071A at a Glance

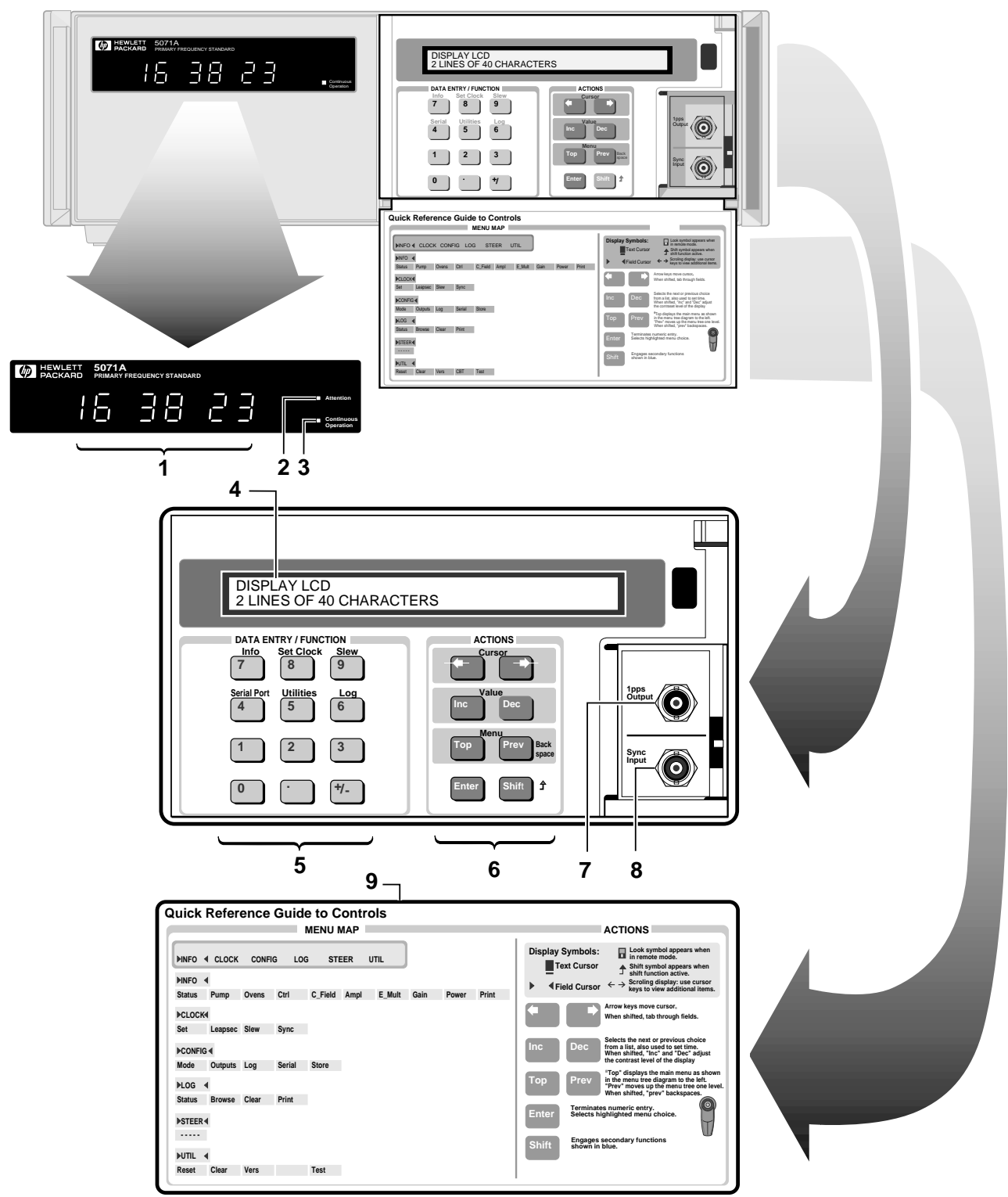

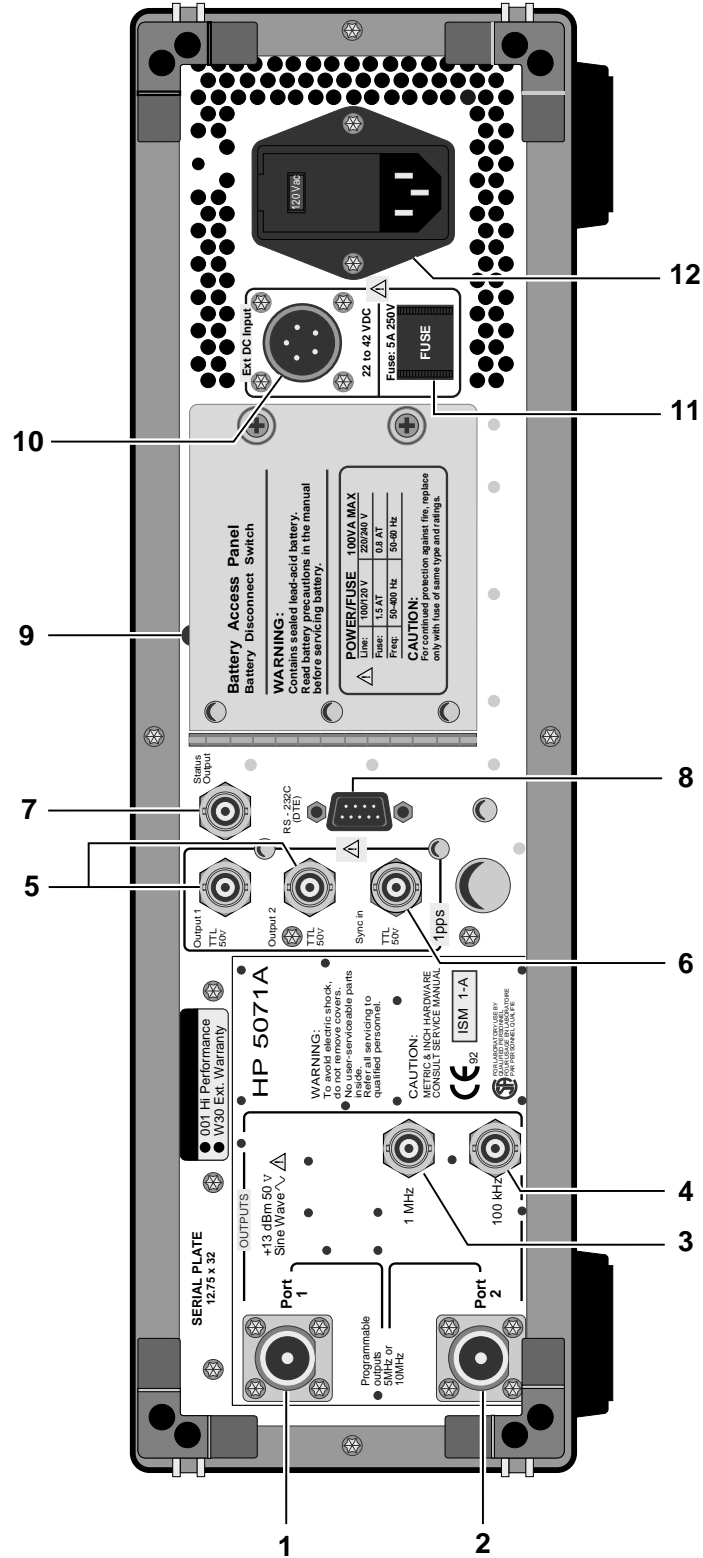

Rear-Panel Connections

The item numbers in Table 1-1 correspond to the callouts in the adjacent illustration on page 1-4.

Table 1-1. Connector Descriptions

Item Number	Function	Connector Type	Signal Characteristics	Program Control	Page Reference
1	Output- Port 1, 5 or 10 MHz	Type N Female	Sinusoidal, 1 Vrms into 50Ω, Nominal	YES	2-5, 2-12, 5-7, 5-20, 6-4
2	Output- Port 1, 5 or 10 MHz	Type N Female	Sinusoidal, 1 Vrms into 50Ω, Nominal	YES	2-5, 2-12, 5-7, 5-20, 6-4
3	1 MHz Output	BNC Female	Sinusoidal, 1 Vrms into 50Ω, Nominal	NO	2-12, 6-4
4	100 kHz Output	BNC Female	Sinusoidal, 1 Vrms into 50Ω, Nominal	NO	2-12, 6-4
5	1pps Outputs	BNC Female	1pps, 20 μs wide, TTL compatible, into 50Ω	YES	1-8, 2-6, 2-12, 5-18, 6-5
6	1pps Sync Input	BNC Female	100 ns to 100 μs wide, +2 to +10V into 50Ω (TTL) Threshold	YES	1-8, 2-6, 2-12, 5-18, 6-5
7	Status Output, Active Low	BNC Female	TTL Open Collector, 1.6 kΩ pull-up to 5V	YES	2-11, 5-33
8	Remote Data Transmission	9-Pin, Male, D-Sub miniature	RS-232C, DTE Configuration	YES	Chap 4, Chap 5
9	Internal Standby Battery Disconnect Switch Access	N/A	Switch disconnects Internal Standby Battery.	NO	2-17, 7-14
10	External dc Power	5-Pin Cannon, Series ME	22-42 Vdc, 100 Watts, Pinout: +22 to +42 Vdc (pin A), Neg. dc (pin C), Chassis Gnd (pin-E), pins B and D are not used	NO	7-12
11	External dc Power Fuse	Cartridge Fuse	Fuses external dc power, 5 Amp fuse	NO	7-13
12	AC Power Input and Fuse	3-prong, Grounded	120/240 Vac, 1.5/0.75 Amp slow-blow fuse.	NO	7-4/7-6

Starting the 5071A

- 1** Inspect the instrument for any damage (see page 7-3 for details).
- 2** Ensure that the ac-power setting, ac line fuse, (rear panel) and supplied power cord are appropriate for your ac-power source.
Refer to Chapter 7, "Installation," for more detailed information.
- 3** Apply power to the instrument.

The amber Attention light illuminates, indicating normal power-up sequence, and the following messages are displayed on the LCD.

The message "Waiting for ion pump start" may appear. If so, it could stay on for up to 20 minutes before the following messages appear.

- a.** Warming up **(Indicates self-test passed successfully.)**
 - b.** Setting Osc. Control
 - c.** Setting RF amplitude
 - d.** Setting E_mult voltage
 - e.** Logging signal levels
 - f.** Setting C-field
 - g.** Locking servo loops
 - h.** Operating normally
- 4** After about 15 minutes, the Attention (amber) light goes out and the Continuous (green) light flashes.

Starting the 5071A

- 5 Press Shift (in the ACTIONS keypad section), then 5 (Utilities): LCD display shows RESET.

Press Enter: This resets the continuous operation circuit, causing the light to be on steadily. Any subsequent fault will cause the Continuous Operation light to go out or flash. (See Chapter 3 for details.)

NOTE

The 5071A will power up at shipment receipt with the following configuration:

Output Ports

Port 1	5 MHz output
Port 2	10 MHz output

RS-232C

Baud rate	2400
Data bits	8
Parity	none
Stop bits	1

System Logs

Printer log	disabled
Error log	cleared *

If your application requires a different configuration, please refer to page 2-15 in this manual.

* 1 entry remains: "Power source is BATT"

Performing Basic Tasks

Things You May Do at Any Time During These Basic Tasks

1. During the following tasks, you may, at any time, return to the Top menu by pressing the **Top** key.
2. At any time, you may cancel a pending operation or data entry task by pressing **Prev**.
3. If you need to adjust the display for better readability, hold down **Shift**, then press **Inc** or **Dec**.

Synchronizing to an External 1 PPS Reference

The 5071A requires a sync pulse with these characteristics:

- +2 to +10 Volts into 50 Ω (TTL Threshold),
- Width = 100 ns minimum to 100 μ s maximum, Rise time <50 ns.

NOTE

The 1PPS output from an 5061A/B or 5071A meets these sync-pulse requirements. As an alternative, the 1pps may be manually synchronized (see page 2-6).

Synchronize the 5071A's 1pps Outputs (to your reference source) with the following procedure:

- 1** Connect a 1pps sync-pulse from your reference clock to the instrument's front (or rear) sync-input.
- 2** Press **Top**, then **◆** once to select the **CLOCK** option.
- 3** Press **Enter**.
SET option of the **CLOCK** menu is selected.
- 4** Press **◆** three times.
SYNC option (**CLOCK** menu) is selected.
- 5** Press **Enter**, then **◆** to select **ARM FRONT** or **ARM REAR**.
- 6** Press **Enter** to arm the selected sync input connection. The 5071A will synchronize to within ± 50 ns on the next sync pulse and the display will show **Caught a sync pulse**. (See Notes on the following page.)

NOTE

While the sync input is armed, *all 1pps outputs and the clock display are stopped*. These resume on synchronization or within 1.5 seconds, whichever occurs first.

If no sync pulse is captured within 1.5 seconds after arming, the selected sync input is disarmed, and the instrument's LCD display shows: `Sync timed out`.

Setting Time and Date

To Set Time

- 1 Press **Shift**, then **8** (Set Clock).
- 2 Set 24-hour time³ (numeric keys), then press **Enter**: the time displays increment immediately.
- 3 Press **◆** to select the Display ON/OFF field, then press **Inc** to turn on the Display.

To Set Date

- 1 Press **Shift**, then **8** (Set Clock).
- 2 Press **◆** twice to select the DATE field.
- 3 Enter the Modified Julian day³ with the numeric keys.
- 4 Press **Enter**.

The new date is shown in the LCD display.

NOTE

Always synchronize the 1pps pulse outputs before setting time and date, otherwise the clock may display incorrect time/date information.

Powering Down the 5071A

When removing power from the 5071A, you'll need to disable the internal-standby battery.

If the 5071A is used in a system or operation where power is removed on a daily or more repetitive basis, it is strongly recommended that the internal standby batteries be physically disconnected. This will prevent excessive discharge/recharge cycles from prematurely depleting standby capacity.

Refer to page 2-17 for the information on how to disable the internal-standby battery.

³See page 2-8 for information about the Modified Julian Day (MJD).

Chapter 1 Getting Started
Performing Basic Tasks

Chapter Contents

This chapter introduces you to the front-panel interface menus and shows how to perform more complex time-keeping tasks.

This chapter is organized as follows:

- Using the Front-Panel Menus page 2-4
 - Keypad Descriptions page 2-4
 - Action Key Functions page 2-4
 - Controlling the 5071A From the Front-Panel page 2-5
- Setting the Output Port Frequency page 2-5
- Setting the 1pps and Clock Outputs page 2-6
 - To Set the 1pps Outputs page 2-6
 - To Synchronize the 1pps Outputs Using a Time-Interval Counter page 2-6
 - To Set the Clock page 2-7
 - To Turn the Clock Display On or Off page 2-8
 - To Schedule a Leap Second page 2-9
- Monitoring Status page 2-10
 - To Select Parameters page 2-10
 - To Interpret Displayed Results page 2-10
 - To Print a Status Report page 2-10
- Reading and Managing the Event Log page 2-11
 - To Check Log Status page 2-11
 - To View Log Entries page 2-11
 - To Clear the Log page 2-11
 - To Print the Log page 2-11
- Steering the Output Frequency page 2-12
 - Steering Explained page 2-12
 - To Add an Offset page 2-12
 - To Check an Offset page 2-13
 - To Remove an Offset page 2-13
- Using Utility Features page 2-14
 - To Reset the Continuous Operation Light page 2-14
 - To Reset the Rear-Panel Status Output page 2-14
 - To Display the Firmware Revision or CBT Identification String page 2-14
 - Diagnostic Self-Tests page 2-14

Chapter Contents

- **Configuring the 5071A** page 2-15
 - **To Set the Operating Mode** page 2-15
 - **To Set the Printer Log Mode** page 2-15
 - **To Set Up the Serial Port** page 2-16
 - **To Save a Configuration** page 2-16
- **Connecting a Printer** page 2-16
- **Disabling the Internal Standby Battery** page 2-17

Using the Front-Panel Menus

Keypad Descriptions

ACTIONS Keypad

The ACTIONS keypad makes menu selections, engages shift functions (DATA ENTRY / FUNCTION: in blue), terminates numeric entry, and controls LCD display contrast.

DATA ENTRY / FUNCTION Keypad

DATA ENTRY / FUNCTION keypad enters numeric data and selects secondary functions (in blue).

Action Key Functions

- 1 Use the **↵** arrow **↔** keys to move around the menus, or when shifted, tab through menu fields.
- 2 Use the **Inc** and **Dec** keys to select the next or previous choice from a list (when shifted adjusts LCD display contrast).
- 3 Use the **Top** or **Prev** keys to move all the way, or one level back up the menu tree.
- 4 Use the **Enter** key to select a menu choice or trigger an action.

Refer to page 1-3 for the available menus, display icons, and conventions.

Setting the Output Port Frequency

Controlling the 5071A From the Front-Panel

You can customize the 5071A's operation by performing a number of tasks after the instrument is running normally (see page 1-8). When you've completed most of these tasks, no further operator intervention will usually be required. Some of these operations can cause the instrument to gain or lose time and are clearly marked with cautions. The suggested operator tasks are:

- Setting the Output-Port Frequency
- Setting the Clock
- Monitoring Status
- Reading and Managing the Event Log
- Steering the Output Frequency
- Using Utility Features
- Configuring the Instrument
- Connecting a Printer
- Disabling the Internal-Standby Battery

More information for using the menus to check instrument status can be found in Chapter 3 of this manual.

Setting the Output Port Frequency

Use this procedure to set the output frequencies at rear-panel ports 1 and 2 to either 5 or 10 MHz.

NOTE

When the frequency of a port is changed and then returned to the previous frequency, the original phase is restored.

- 1** Select the `CONFIG` menu, then press **Enter**.
- 2** Select `OUTPUTS`, then press **Enter**.
- 3** Choose `Port 1` or `Port 2`, then press **Inc** or **Dec** to set frequency.

Setting the 1pps and Clock Outputs

Use the following information to adjust the 5071A's clock and synchronization functions.

To Set the 1pps Outputs

Set the 1pps outputs before setting the clock display for time or date. The timing of the 1pps output signal can be synchronized with a reference 1pps signal in two ways: automatically or manually.

- The automatic method requires a reference-sync input signal and is described on page 1-8.
- The manual method is used when an appropriate reference-sync input pulse is not available, or when you need to offset the instrument's 1pps output signal from a reference pulse by a specific time interval.
- The manual method can also be used to arbitrarily move (slew) the 1pps signal in time. (If you want to move the 1 pps signal without using a time-interval (TI) counter, simply use the last three steps of the following procedure.)

All three of the instrument's 1pps outputs are synchronous and isolated from one-another. Changes made to the 1pps output signal timing have no effect on the 10, 5, 1, or 0.1 MHz output signals.

To Synchronize the 1pps Outputs Using a Time-Interval Counter

You can manually synchronize the 1pps outputs with another frequency standard or system (± 50 ns) if a Sync input signal is not available as described in Chapter 1. A high resolution TI counter should be used when synchronizing the 5071A with another clock or system with the following considerations:

- TI measurements should include consideration of cable-length delay.
- Use 50Ω termination on the 1 PPS lines to reduce ringing.

Use the following procedure to synchronize the 1pps outputs manually:

- 1** Connect the reference 1 PPS signal to the START input of the TI counter.
- 2** Connect the 5071A's 1pps Output to the STOP input of the TI counter.

Setting the 1pps and Clock Outputs

- 3 Set the counter's trigger-level controls to trigger on the leading edge of each signal at the 50% amplitude point. (for the 5071A with 50 Ω termination: trigger slope = Positive, trigger level = +1.5 Volts)
- 4 Read the time difference on the counter.
- 5 Adjust the 1pps timing (select Slew) by pressing **Shift**, then **9**.
- 6 Enter the counter reading in microseconds into the Epoch Advance value field.
- 7 Press **Enter** and observe the TI counter reading for confirmation.

NOTE

Positive values advance the 5071A's 1pps in time, while **negative** values retard it. The resolution of the Slew control is 50 ns. (You will need to make more than one adjustment if the initial TI counter reading exceeds 500 ms.)

Check the time and date on the 5071A after you've synchronized the 1pps outputs.

To Set the Clock

Setting the Time

- 1 Select the `CLOCK` menu.
- 2 Set 24-hour time (numeric keys), then press **Enter**.

The clock setting increments immediately.¹

- 3 To turn on the LED display, see page 2-8.

Setting the Date

- 1 Select the `CLOCK` menu.
- 2 Press **◆** twice to bracket the `DATE` field.

¹ You can use the Inc/Dec keys to make small adjustments.

Setting the 1pps and Clock Outputs

- 3** Enter the correct Modified Julian Day (MJD) with the numeric keys.
(See the MJD information below and Table 2-1.)
- 4** Press **Enter**.

The new date is shown in the LCD display.

The Modified Julian Day (MJD)

During the course of configuring and using the 5071A, you'll have occasion to set the date. The 5071A uses the MJD to date log entries as well as tagging the day that a leap second is to be added or subtracted.

The MJD is a widely accepted method of providing each day with a unique number and is used with Coordinated Universal Time (UTC). The MJD changes at midnight, and increments in the 5071A when the clock display reaches 00:00:00. This ensures that the instrument is correctly synchronized with the MJD.

The easiest way to determine the MJD is to add the number of days between the current date and a recent known MJD. For example, December 31, 1991 is MJD 48621. January 5, 1992 was (48621 + 5) or MJD 48626. MJD's for December 31 are given in Table 2-1.

Table 2-1. Modified Julian Days

December 31,	MJD	December 31,	MJD
1992	48987	1997	50813
1993	49352	1998	51178
1994	49717	1999	51543
1995	50082	2000	51909
1996	50448	2001	52274

To Turn the Clock Display On or Off

Use the following procedure to control the clock display:

- 1** Select the **CLOCK** menu.
- 2** Press **◆** to enter the clock display control field.
- 3** Press the **Inc** or **Dec** keys to toggle the display **ON** or **OFF**.

Setting the 1pps and Clock Outputs

To Schedule a Leap Second

You can pre-program the 5071A to add or subtract a leap second on a designated MJD.

- 1 Select the `CLOCK` menu.
- 2 Select `LEAPSEC`, press **Enter**, enter the effective date (MJD), and press **Enter**.

This is the MJD on which the change is to occur at 23:59:59.

- 3 Select the next field by Pressing the **↵** key.
- 4 Press **Inc** or **Dec** to choose 59 or 61, depending on whether a leap second is to be added or subtracted.

Display shows Leap second is pending. The leap second will occur as desired without further input. When the desired MJD has arrived, an entry will be placed into the Status Log at 23:59:57 indicating that either a short or long minute has occurred.

Monitoring Status

Use the following procedures to check the 5071A's operational status and selected internal parameters.

To Select Parameters

Press **Shift**, then **7** (INFO): display shows instrument status.

Select the reading you want to check then use the cursor keys to examine the instrument's status.

To Interpret Displayed Results

The front-panel LCD display shows the current status (or value) of the selected parameter. Refer to Table 2-2 below for typical internal-parameter operating ranges and definitions.

Table 2-2. Internal Operating Parameters

Parameter	Description	Typical Range
Pump	Ion pump current	0 - 40 μ A
Ovens	Cesium beam tube and VCXO Oven monitor	0 to 10V, and -5 to -10V
Ctrl	VCXO control voltage	-95 to 95%
C-Field	C-field control current	10.0 to 14.05 mA
Ampl	Microwave signal strength for CBT (% of maximum)	0 to 100%, and 0 to 100%
E_Mult	CBT electron multiplier voltage	1000 to 2553V
Gain	Frequency control loop gain (% of maximum)	14.4 to 58%
Power	Voltage source	AC, DC, or Battery

To Print a Status Report

Use the following procedure to print a status report when a printer is connected to the rear-panel RS-232C serial port (see page 2-16).

- 1 Select the `INFO` menu.
- 2 Select the `PRINT` option and press **Enter**.

Reading and Managing the Event Log

The event log contains a history of such things as power-supply status, errors, and warnings. A maximum of 192 entries can be recorded with each numbered entry time-and-date stamped. When the log is full, no more entries can accumulate. Therefore, you should periodically examine the log and clear entries.

To Check Log Status

Use the following procedure to see how many entries are in the event log.

- 1 Select the `LOG` menu, then press **Enter**.
- 2 Select `STATUS`.

The number of log entries is displayed.

To View Log Entries

Use the following procedure to read event-log entries.

- 1 Select the `LOG` menu, then press **Enter**.
- 2 Select `BROWSE`, then press **Inc** or **Dec** as needed to read the entries.

To Clear the Log

This procedure clears the entire log. Cleared entries cannot be recovered.

- 1 Select the `LOG` menu, then press **Enter**.
- 2 Select `CLEAR`, then press **Enter** to clear the entire log.

To Print the Log

Use the following procedure to print the log contents when a printer is connected to the rear-panel RS-232C serial port (See page 4-3).

- 1 Select the `LOG` menu, then press **Enter**.
- 2 Select `PRINT`, then press **Enter**.

Steering the Output Frequency

Steering Explained

In normal operation, the output frequencies of the 5071A are in fixed relation to the Cesium Beam tube response. This relationship provides the basis for traceability of the 5071A to the international definition of time.

The STEER menu lets you change output frequencies in a calibrated manner with great precision. Changes can be made manually (front panel), or via the serial interface (SCPI commands). The 5071A's output Steerability facilitates its use in active-clock ensembles. It also gives you a convenient way to make controlled changes in the phase of the rear-panel sinusoidal and 1pps outputs.

For example, a reserve standard can be brought into phase with a working standard before the two are interchanged. You can also make changes in the timing of the 1pps output signal with greater precision than provided by the Slew control's ± 50 ns resolution. Simply, Steer the output frequency for a suitable length of time.

The resolution unit of the STEER function is 6.331991×10^{-15} , and the range of the fractional frequency offset is $\pm 999999 \times 10^{-15}$. When you STEER the instrument's output frequency, you must take into account the exact amount of the offset to establish and maintain traceability and accuracy. The frequencies of the sinusoidal outputs and the rate of the 1pps outputs change by the same fractional amount when the output is steered.

Use following procedures to add, check, or remove a fractional frequency offset when using the 5071A:

To Add an Offset

- 1 Select the STEER menu, then press **Enter**.
- 2 Enter the desired fractional frequency offset in units of 1.0×10^{-15} using the numeric keypad.

Steering the Output Frequency

- 3 Press **Enter** to initiate the offset, or **Prev** to cancel the operation and return to next-higher menu level.

NOTE

The 5071A rounds the entered offset to the nearest multiple of 6.331991×10^{-15} , and displays it when you press **Enter**. The rounded value is displayed to a resolution and accuracy of 1×10^{-15} .

When the output frequency is steered, the ATTENTION light flashes, indicating that the output frequency and clock rate contain an intentional deviation.

NOTE

The steering value is NOT stored in the 5071A non-volatile memory. If the Continuous operation LED is flashing any time after a reset, it indicates that power was lost during operation. This would mean that any steering value you have previously entered is no longer in effect. You will need to re-enter the steering value as part of the reset procedure.

To Check an Offset

Use the following procedure to determine the value of an active offset.

- 1 Select the STEER menu, then press **Enter**.

The LCD display shows the current offset value with an accuracy of 1×10^{-15} .

- 2 Leave the active menu by pressing **Prev**.

To Remove an Offset

- 1 Select the STEER menu, then press **Enter**.
- 2 Press **0**, then **Enter** to clear the offset.

The ATTENTION light goes out.

Using Utility Features

Use the following procedures to run selected utility functions.

To Reset the Continuous Operation Light

Use the following procedure when the Continuous Operation light is flashing.

NOTE

If the Continuous operation LED is flashing any time after a reset, it indicates that power was lost during operation. If you are concerned with timing, phase, or if you had been steering the frequency you will need to re-synchronize the timing and phase and/or re-enter the steering value as part of the reset procedure.

- 1 Press **Shift**, then **5** (UTILITIES): the LCD display shows `RESET` selected.
- 2 Press **Enter**.

The Continuous Operation light is now continuously lit.

To Reset the Rear-Panel Status Output

- 1 Select the `UTIL` menu, then press **Enter**.
- 2 Select `CLEAR`, then press **Enter**.

NOTE

Resetting the Status Output results in a “high” logic state when the instrument is operating normally.

To Display the Firmware Revision or CBT Identification String

- 1 Select the `UTIL` menu, then press **Enter**.
- 2 Select `CBT` or `VERS`, then press **Enter**.

Diagnostic Self-Tests

CAUTION

Running these tests requires Standby Mode, disrupting the instrument’s time keeping and output frequency functions.

The `TEST` option of the `UTIL` menu is provided for use by qualified personnel only. Refer to the Assembly-Level Service manual for more information.

Configuring the 5071A

Use the following procedures to customize the operation of the 5071A for your specific time-keeping needs.

To Set the Operating Mode

Use the following procedure to change the instrument's operating mode from Normal to Standby. The standby mode is useful for such things as long-term storage and non-operator maintenance procedures (refer to the Assembly-Level Service manual.).

CAUTION

When you put the 5071A into Standby mode, the Cesium Beam tube is shut-down except for the Ion pump. The 5071A will not maintain accurate time or frequency in this mode. Placing the instrument back into Normal mode initiates the normal CBT power-up sequence.

- 1 Select the `CONFIG` menu, then press **Enter**.
- 2 Select `MODE`, then press **Enter**.

Use the **↵** or **⬅** keys to select `NORMAL` or `STANDBY`, then press **Enter**.

To Set the Printer Log Mode

The internal event log can report several different levels of information to the instrument's rear-panel RS-232C serial port when a printer has been connected to the instrument and correctly configured. Four levels of information depth are available:

- `Disable` - No information is printed,
- `Terse` - prints only Fatal errors,
- `Verbose` - prints all functional and internal progress information,
- `Service` - adds detailed power-on and warm-up events to Verbose level.

Use the following procedure to select the printer-log mode for the 5071A:

- 1 Select the `CONFIG` menu, then press **Enter**.
- 2 Select `Log`, then press **Enter**.
- 3 Press the **Inc** or **Dec** keys to select `DISABLED`, `TERSE`, `VERBOSE`, or `SERVICE`, then press **Enter**.

Connecting a Printer

To Set Up the Serial Port

You can configure the instrument's rear-panel RS-232C serial port from the front-panel with the following procedure. (Refer to Chapter 4, page 4-3 for detailed remote operation set-up information.)

- 1 Select the `CONFIG` menu, then press **Enter**.
- 2 Select `SERIAL`, then press **Enter**.
- 3 Use the **↗** or **↘** keys to select a port parameter, then press **Inc** or **Dec** as needed to adjust each parameter value.

To Save a Configuration

Use this procedure to save your selected configuration choices into non-volatile memory.

- 1 Select the `CONFIG` menu, then press **Enter**.
- 2 Select `STORE`, then press **Enter**.

NOTE

This stores the Display angle, Output frequencies, Serial port settings, and Log mode in non-volatile memory.

Connecting a Printer

You can connect a printer to the 5071A to create hardcopy output of the internal event log entries or print current status.

Refer to Chapter 4, "Remote Operation and Programming," in this manual to connect and configure a serial printer to the instrument's RS-232C port.

Disabling the Internal Standby Battery

When ac (or external dc) power is removed, the internal-standby battery will automatically power the instrument unless disabled. Use the following procedure to disable (turn off) the internal-standby battery. This is useful when you need to turn off the instrument without discharging the internal battery.

NOTE

Because of the long-term storage design of the 5071A internal lead-acid batteries, we do not recommend that the 5071A internal batteries be used in situations where power is removed on a daily basis. If this is your situation, the internal batteries will be constantly subjected to discharge and possibly not receive the necessary full 16 hours re-charge during each typical work day. Such repeated partial charge and discharge cycles can permanently damage the battery's storage capacity. (Refer to Chapter 7, "Internal Standby Battery Maintenance" and "Battery Charging," for more information.)

If your situation requires you to operate the 5071A under these conditions, it is strongly recommended that the internal batteries be manually disconnected each time power is removed, or permanently disconnected. This will ensure that the batteries are not stressed by continual under-charging.

-
- 1** Locate the battery disconnect switch hole just above the battery-access door on its left side (rear panel).
 - 2** Insert any insulated non-metallic 1/8" (3 mm) rod into the opening, depress the momentary switch button and release.
 - 3** Confirm that the instrument remains off by checking that no front-panel indicators are on.
 - 4** If you need to disconnect the internal battery pack, (for instance, long-term storage) open the battery access door and unplug both pairs of the locking connectors.

NOTE

The 5071A will function normally from ac and auxiliary dc power with the internal battery disconnected.

Disabling the Internal Standby Battery

Chapter Contents

This chapter gives you information to examine, analyze, and resolve unexpected operating results and situations.

This chapter is organized as follows:

- **Front-Panel Indicators and Messages** page 3-3
 - **Clock Display** page 3-3
 - **Attention Light** page 3-3
 - **Continuous Operation Light** page 3-3
 - **LCD Display** page 3-4
 - **Instrument States** page 3-5
 - **Front-Panel Warning Messages** page 3-6
- **Power-up Problems** page 3-7
- **Using Menus to Check Operational Status** page 3-8
 - **INFORMATION Menu** page 3-8
 - **LOG Menu** page 3-8
 - **UTILITIES Menu** page 3-8
 - **CLOCK Menu** page 3-8
 - **CONFIGURATION Menu** page 3-8
- **Operating System Failure** page 3-9
 - **Operating System Failure Symptoms** page 3-9
 - **Restarting the 5071A** page 3-9
- **Verifying Operation** page 3-10
- **Cesium Beam Tube Life** page 3-10

Front-Panel Indicators and Messages

You can use the front-panel indications and messages to assess the instrument's operation and status. The warning messages that can appear on the front panel LCD are listed and explained on the next two pages. Warning messages and states indicate that the instrument cannot proceed with an entered front-panel command or has left the normal operation state. The front-panel indicators are shown and briefly explained on page 1-2 and 1-3 of Chapter 1. These displays and indicators (Table 3-1) have the following characteristics and functions:

Clock Display

Consists of six large seven-segment red LEDs that display 24-hour time.

Attention Light

Illuminates continuously to warn you if the instrument is running in a non-normal operating condition or needs attention. The Information Status display (read from the LCD display) will tell you why. (See page 2-10, "Monitoring Status," for more information.)

Flashes when the instrument is approaching (or has entered) a failure mode. (See "Instrument States," next page for more information.) View the Event Log for more detailed information. (Refer to the front-panel Quick Reference Guide to Controls or Chapter 2 of this manual to read the Event Log.)

Continuous Operation Light

Flashes after a normal power-on sequence then, is lit continuously after manual or remote Reset of the Continuous Operation state. The Continuous Operation light lets you verify that the instrument has been functioning continuously as a frequency standard since it was last Reset.

Is off when the instrument enters a Fatal error state or is in standby mode. When this happens, the Attention light flashes. (See "Instrument States," on page 3-5 for more information.)

NOTE

If the Continuous operation LED is flashing any time after a reset, it indicates that power was lost during operation. If you are concerned with timing, phase, or if you had been steering the frequency you will need to re-synchronize the timing and phase and/or re-enter the steering value as part of the reset procedure.

LCD Display

Consists of two 40-character lines that can show you:

- Active functions and menus
- Active operating settings
- Available menu choices and options
- Internal operating parameters
- Warning messages (see page 3-6)

Table 3-1. Front-Panel Status Lights

<i>ATTENTION (Amber) Light</i>			
<i>CONTINUOUS OPERATION (Green) Light</i>	OFF	Flashing	ON
OFF	Power is OFF, the internal battery is discharged, or disabled/disconnected	Fatal Error (See Fatal Error instrument state below)	Warm-up or Standby Mode (See Front-panel Message)
Flashing*	Ready to set Continuous Operation (Continuous Operation NOT Set)	Running on battery (Continuous Operation Not Set)	Steered Output (Continuous Operation NOT Set)
ON	Normal Operation (Continuous Operation Set)	Normal Operation with Battery Power or Warning state (See Warning Instrument state below.)	Normal Operation with Steered Output

* IMPORTANT - The flashing Continuous LED can also indicate that power has been disrupted and then restored. If this happens and timing, phase, or steering are critical to your application, you must check these and make any necessary corrections when performing a reset.

Front-Panel Indicators and Messages

NOTE

Once the Continuous Operation light has been set to ON (not flashing) using the reset procedure, flashing could indicate that a power interruption has occurred. There are two important consequences involved with power interruption during continuous operation, and these should be considered:

If you are concerned with timing, phase, or if you had been steering the frequency you will need to re-synchronize the timing and phase and/or re-enter the steering value as part of the reset procedure.

If the internal battery became exhausted while attempting to sustain operation, it cannot be assumed that it is completely re-charged until the 5071A has been connected to ac mains for at least 16 hours.

Instrument States

The 5071A has six operational states as follows:

1. **Power On:** Initial start-up phase; performs self-tests and initiates warm up.
If any self-tests fail, the next state is “Fatal error”, see below.
2. **Warm up:** During warm up, CBT and VCXO ovens heat to operating temperature. The instrument then attempts to auto-lock its servo loops. If successful, the next state is Normal operation. If there is a failure, the next state is “Fatal error”, see below.
3. **Normal Operation:** Runs internal software continuously to check and adjust the instrument’s operation. The Continuous Operation light flashes, and the user may reset continuous operation at this point. Transition to a “Warning” state occurs when internal software detects a Warning condition.
4. **Warning:** The Continuous Operation light is extinguished as long as the detected Warning condition persists. The instrument may return to Normal operation upon user request (Reset Continuous Operation command) if the Warning condition clears. Specific Warning messages may be read from the instrument’s front panel via the LOG menu choice.
5. **Standby:** This state may be entered any time the user requests. The only way to leave this state is by user request. The Cesium Beam tube is turned OFF (see page 2-15 under “To Set the Operating Mode”).
6. **Fatal Error:** This state is active when the instrument detects a non-recoverable error. The only way to exit the fatal error state is by cycling power to the unit. Specific messages may be read from the instrument’s front panel via the Log Menu choice.

Front-Panel Warning Messages

If you attempt an operation that isn't allowed, the 5071A will make an audible beep and display one of three possible warning messages:

Remote Mode

The LCD display shows the small padlock symbol at the far right-hand side of the screen. You attempt schedule a leap second, but when you press **Enter**, the instrument beeps and displays:

```
"Remote Mode: front panel locked out",  
"      (Press any key to continue)"
```

Standby Mode

The 5071A is in Normal mode. You attempt to run the diagnostic self-tests, but when you press **Enter**, the instrument beeps and displays:

```
"Valid only when in standby"  
"      (Press any key to continue)"
```

Steered Operation

The 5071A is warming-up. You attempt to steer the output, but when you press **Enter**, the instrument beeps and displays:

```
"Valid only when operating normally"  
"      (Press any key to continue)"
```

Power-up Problems

In general, the 5071A will power-on and warm-up within approximately 15 minutes and operate to specifications after 30 minutes. Some instruments may take slightly more or less time to do so and represent a normal variation of start-up performance. There are, however, circumstances that are associated with a lack of any activity or, cause fatal error states to occur (see event log) by preventing a normal power-on/warm-up sequence. These situations are listed along with a suggested remedial procedure.

- If you attempt to start the 5071A and observe no signs of activity:
 1. Disconnect the instrument from ac and/or external-dc power (if present).
 2. Check the ac fuse located in the rear-panel ac power module (also check the dc fuse if external-dc power is present).
 3. Replace the fuse as needed, then attempt restart.
 4. If the fuse blows again, disconnect power immediately and contact your nearest Agilent Sales and Support office for assistance.
- If you attempt to start the 5071A when its temperature is below 0° Centigrade, the allotted maximum 45-minute power-up/warm-up time may not be sufficient to heat both the Cesium Beam tube oven and VCXO oven.
 1. Let the instrument warm up to room temperature.
 2. Attempt to restart the instrument.
- If you connect 240-volt power to the instrument when it is set for 120 volts, the ac-power fuse will blow.
 1. Replace the ac-power fuse.
 2. Wait at least 15 minutes as required by internal power-supply circuit time constants.
 3. Attempt to restart the instrument.
- If you attempt to start the 5071A in a normal operating environment with the correct ac-voltage set and the instrument reports a fatal error or appears otherwise unresponsive.
 1. Attempt restart twice if the instrument does not power up.
 2. Contact your local Agilent Sales and Support office for assistance.

Using Menus to Check Operational Status

The section provide suggested ways to use the menus for checking the operational status of the 5071A. A specific procedure for each menu is provided in Chapter 2, “Using the 5071A.”

INFORmation Menu

Use the INFO (Information) menu to check:

- Overall operating status, and to
- Examine specific values of the instrument’s internal operating parameters

LOG Menu

Use the LOG menu to check:

- Instrument’s most recent operating history, and to
- Print a copy of the current log contents

UTILities Menu

Use the UTIL (Utilities) menu to:

- Check the firmware revision and View CBT Identification string, and
- Clear (reset) the rear-panel Status Output

CLOCK Menu

Use the CLOCK menu to check the:

- Active clock time and date settings,
- Current leap-second settings, and
- Last used slew value

CONFIGuration Menu

Use the CONFIGURATION menu to check the current configuration for the instrument’s:

- Operating mode,
- Printer log operation,
- Output ports, and
- Serial port

Operating System Failure

This section provides information to check symptoms associated with operating system failures and a procedure to restart the 5071A in the event of such a failure.

Operating System Failure Symptoms

Five symptoms are associated with operating system failure:

- **Continuous Operation light extinguished:** The front-panel Continuous Operation light is out and does not light with attempts to reset continuous operation.
- **Deteriorating Stability and Accuracy:** Although the instrument's rear-panel outputs are electrically active, the observed stability and accuracy are out of specification with no frequency offsets present or output steering active.
- **Clock Stops:** The large front-panel LED clock display and CLOCK menu time display fail to show incrementing time.
- **Unresponsive Front-Panel:** Attempts to issue commands from the front-panel keys fail to cause any LCD display update or changes to the instrument's rear-panel output functions. Refer to the restart procedure.
- **Unresponsive Rear-Panel RS-232C Serial Port:** Attempts to issue commands through a correctly configured rear-panel RS-232C serial port fail to cause any remote terminal display update and/or changes to the instrument's rear-panel output functions. Refer to the restart procedure.

Restarting the 5071A

Check all configuration and operating commands issued from the front-panel or through the RS-232C-serial port immediately prior to the operating system failure. Attempt to determine if the failure occurred in association with any recent changes in the instrument's environment or power source.

Use the following procedure to restart the 5071A in the event of an operating system failure.

- 1 Remove external-dc power (if connected).
- 2 Remove ac-line power.

Verifying Operation

- 3 Disable the internal battery by operating the rear-panel battery-disconnect switch. (Refer to “Disabling the Internal Standby Battery” on page 2-17 for details.)
- 4 Re-apply ac-line power.
- 5 Observe the instrument for successful completion of the normal power-up and warm-up sequence.

Verifying Operation

Perform the Operational Verification starting on page A-4 of Appendix A, “Performance Tests,” to verify that the 5071A is operating properly.

Cesium Beam Tube Life

This section provides information to check the Long-Term operating status of the instrument’s Cesium Beam tube.

The primary symptom associated with terminal Cesium Beam tube life is a progressive deterioration in the instrument’s output stability or accuracy. Eventually, the Continuous Operation light may extinguish (for no discernible reason) but can be reset momentarily after any warnings have cleared.

If these symptoms occur:

- 1 Select the front-panel INFOrmation menu, then press **Enter**.
- 2 Check the `E_Mult` parameter for an excessive increased or decreased value. (See Table 2-2 on page 2-10 for typical values.)
- 3 Check the `Gain` parameter for an excessive increase in value. (See Table 2-2 on page 2-10 for typical values.)
- 4 The presence of these two parameters at these extremes along with poor instrument output stability and accuracy is consistent with Cesium Beam tube failure.
- 5 Search for Log messages that contain information relevant to Cesium Beam tube performance.
- 6 Contact your nearest Agilent Sales and Support office for assistance.

Chapter Contents

This chapter gives you the information required to set up and operate the 5071A as a remote device.

This chapter is organized as follows:

- Remote-Operation Setup page 4-3
 - Overview page 4-3
 - Hardware Connection page 4-4
 - Serial-Port Configuration page 4-6
- Remote-Modem Setup and Precautions page 4-8
 - Overview page 4-8
 - Modem Selection page 4-8
 - Modem Configuration page 4-8
 - Verifying Remote Operation with a Terminal page 4-9
- Programming Overview page 4-10
- SCPI Command Conformance page 4-11
- Command Types page 4-12
 - Common Command Format page 4-12
 - SCPI Command and Query Format page 4-12
 - *RST Reset Response page 4-16
- Sample Program Commands page 4-17
 - Status Monitoring Tasks page 4-18
 - Instrument Control Tasks page 4-19
- Batch Processing for the Program Commands page 4-21
 - Command Scripts On a Personal Computer page 4-21
 - SCPI Considerations For HP BASIC page 4-22
 - Example Program page 4-24
- Tips on Using the RS-232C Port on the 5071A page 4-27
 - Keypad Lock-Ups: Why do they occur and how are they cleared? page 4-27
 - Using Ctrl-Q in Programs page 4-29

Remote-Operation Setup

Overview

Remote Interface Features

The 5071A's remote or serial port interface provides a variety of features for such tasks as:

- Terminal operation (or terminal emulation) to allow single-line command entry and display of instrument response.
- Remote control via computer programs or scripts to facilitate multiple command-line tasks (with or without a modem).
- Output to a printer to provide hardcopy record of the instruments internal operation and Event log.
- Remote communication using a modem (short-haul or telephone line) to increase the effective distance between an operator for controlling computer and the 5071A.

These features are discussed as they occur for hardware setup (in this section) and later for software beginning with the Programming Overview section in this chapter and command reference information in Chapter 5.

Serial-Port Description

The 5071A's serial port is a DTE device that may be connected to a printer, terminal, computer, or modem. The available transmission protocol features are:

- RS-232C serial port supports both XON/XOFF (software) or DTR-DSR (hardwired) pacing. Both are always enabled with the DSR input transparent when not connected.
- Baud rate, Handshaking include 300-9600 baud, 7 or 8 data bits, 1 or 2 stop bits, and odd, even, or no parity
- Input End-of-Line character line-termination with CR (ASCII 13, decimal), LF (ASCII 10, decimal), one followed by the other in either order. The 5071A's line termination of formatted output is <CR> and <LF>.

Remote-Operation Setup**Hardware Connection**

The rear-panel serial-port connection uses a 9-pin Male, D-Subminiature connector. Signal voltage levels comply with the RS-232C standard. The serial-port connections are electrically isolated from the 5071A's ground and circuitry. The serial port pin assignments are listed below:

Pin	Function
1	Not connected
2	Received data (<i>To 5071A</i>)
3	Transmitted data (<i>From 5071A</i>)
4	Not connected
5	Signal Ground
6	Data Set Ready - DSR (<i>To 5071A</i>)
7-9	Not connected

See Figure 4-1 for the different RS-232C cabling-connection setups. Use the appropriate setup that meets your remote operation needs.

Chapter 4 Remote Operation and Programming
Remote-Operation Setup

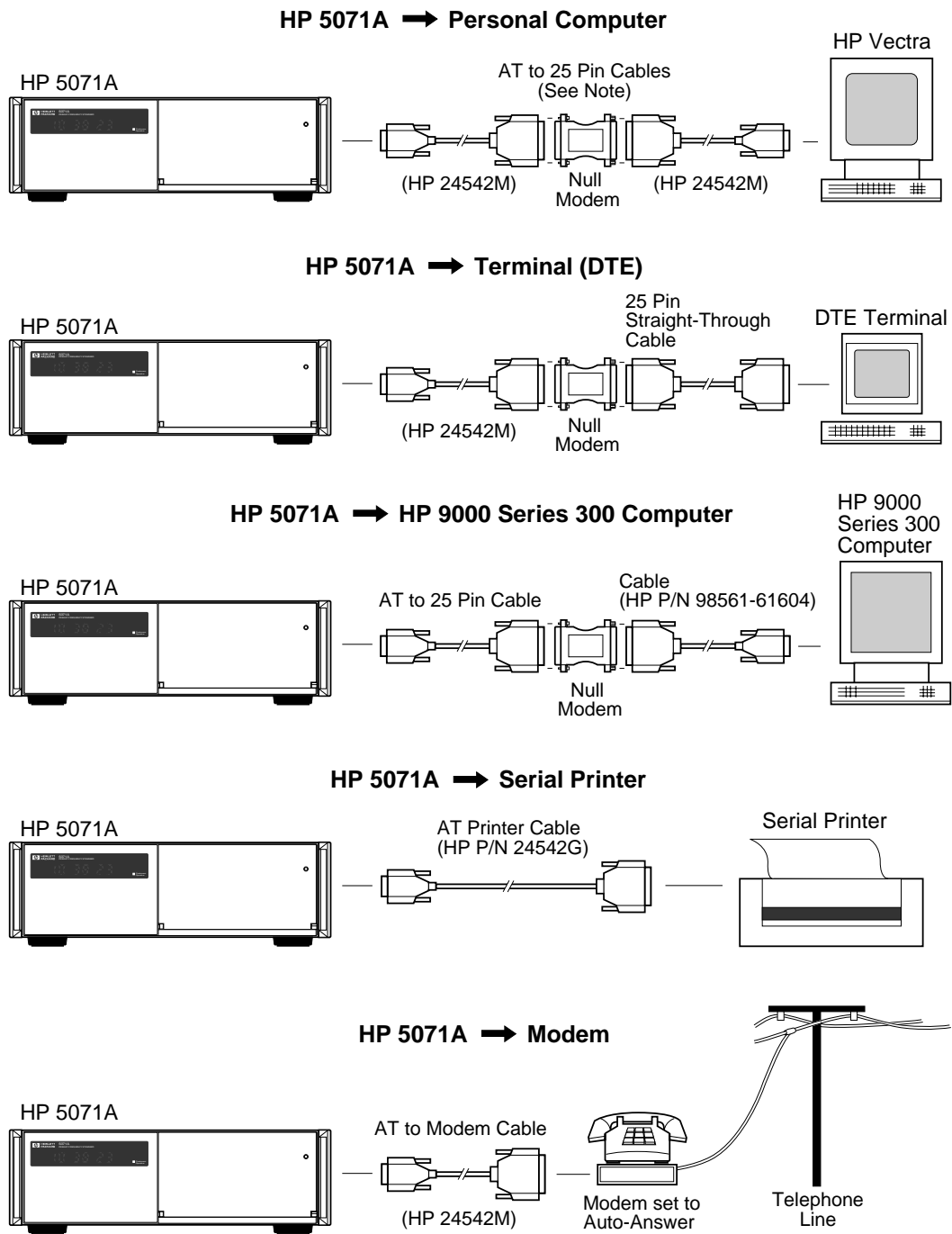

Note: The HP 24542M cables and Null Modem may be replaced by a single HP 24542H cable.

Figure 4-1. RS-232C Cabling Setups

Remote-Operation Setup

Serial-Port Configuration

Once the instrument is properly connected to a device (terminal, computer, or PC, etc.) configure the device to match the following default communications settings of the 5071A:

- Baud Rate: 9600
- Parity: None
- Data Bits: 8
- Stop Bits: 1

If you are using an NT[®] 4.0-based or Windows[®] 95-based PC to communicate with your 5071A, perform the following steps to configure the PC's serial port to match the 5071A's serial port.

The steps to configure the PC's serial port are:

- 1** In Windows NT (or Windows 95), main window, click the **Start** button then select **Programs**.
- 2** Select **Accessories, Hyperterminal, and Hyper Terminal**.

The **Connection Description** dialog box is displayed.

- 3** In the "Name" window, type 5071A (for example), select one of the icons (the first one will do), then click **OK**.

The **Connect To** dialog box is displayed.

- 4** In the "Connect using" window, select the appropriate port or connector (COM1 or COM2), then click **OK**.

The **COM1 (or COM2) Properties** dialog box is displayed. This dialog box allows you to configure the RS-232 port of your PC.

- 5** Set the RS-232 port of your PC to match the default values of the 5071A.

Once you've enabled the correct COM port from your PC, a prompt should appear each time you press the enter (or return) key.

Remote-Operation Setup

The prompt will look either like **scpi >** or something like **E-113>** if an error has occurred. Following the prompt you can type the command you want to send. For commands that produce a response, the reply will appear on screen. For example, sending ***idn?** asks the instrument to identify itself. The transaction might look something like this:

```
scpi > *idn?
```

```
AGILENT,5071A,US38400000,3840-A
```

```
scpi >
```

After you've selected the communication parameters for your terminal, be sure to configure the 5071A's serial port with the same values, using the CONFIG menu's Serial option.

Remote-Modem Setup and Precautions

If you chose to connect a modem to the 5071A, read this information and observe the necessary precautions to setup remote communication via telephone lines.

Overview

The 5071A's RS-232C serial interface allows the control and monitoring functions usually performed by a terminal or computer to be carried out over a much greater distance. For example, two short-haul modems can separate the 5071A and a computer by thousands-of-feet instead of the tens-of-feet permitted by the RS-232C standard.

The use of a modem set for auto-answer also allows the 5071A to be operated and maintained over telephone lines, so the 5071A can be operated in a remote location with no loss of control. If a modem is used to connect the instrument directly to public telephone lines, there exists the possibility of accidental or intentional interference with the instruments operation. Since the instruments communication protocol does not provide password protection, connection via a computer or suitably programmed dial-back modem is preferable.

Modem Selection

The modem used to control the 5071A must be capable of operating without hardware handshake and should be connected to provide an asserted DSR signal to the 5071A. The pin-out of the 9-pin serial connector on the rear panel of the 5071A is listed at the beginning of this chapter.

Modem Configuration

The 5071A communication protocol does not use any special features for modem operation, and does not recognize any modem system prompts. Thus, the modem must be preset not to emit any characters except those received over the communication path. If the modem is attached to a telephone line it must be configured to operate in the "auto-answer" mode. Many modems can be set up with switches to operate this way.

Remote-Modem Setup and Precautions

Under these conditions, the communication-path configuration is handled by the calling computer or terminal, and the link to the 5071A works as it would for a direct RS-232C connection. The calling computer and 5071A must be set to the same Baud rate at the outset. If the instrument is to communicate with a computer, the Baud rate should be chosen for a low data error rate, as errors may be difficult to handle. To set up your modem, follow the manufacturers instructions.

CAUTION

The 5071A should only be connected via a modem to public telephone lines when communication is specifically needed. If permanent connection over telephone lines is required, a dedicated line or computer-implemented password protection is strongly advised.

Verifying Remote Operation with a Terminal

Use the following steps to verify proper operation of your data communications link between the 5071A and remote terminal.

- 1** Ensure that the correct hardware connections exist between the 5071A and your terminal as shown on page 4-5.
- 2** Ensure that the 5071A and your data communications equipment (terminal) are powered-up and have passed their own self-tests.
- 3** Press the “Enter” or “Return” key on your terminal several times.
- 4** Observe the returned `scpi >` prompt on the terminal screen.
- 5** If the prompt does not appear:
 - Check and verify all serial port parameters mentioned on page 4-6, or
 - Check and verify the hardware connections and cabling for correct DTE- DCE signal paths, or
 - Check and verify all cables and connections for open or shorted lines

Programming Overview

Programming for the 5071A includes several levels of control via the serial interface:

- Single SCPI command-line entry and instrument response
- Multiple SCPI command-line entry as data communication program scripts
- Automated SCPI control using an instrument controller

The control examples included in this chapter illustrate the single-line command entry level for a terminal session. Once this level is appreciated, you can build task scripts and more complex programs by reading further in this chapter and referencing the next chapter of command reference information.

The next several pages provide the minimum introductory information about the 5071As programming command format, syntax, and *RST response (initialization state). After reading this section you will have a basic knowledge of how to use and understand the SCPI commands for the 5071A Primary Frequency Standard.

The details of the 5071A's SCPI and IEEE Common Commands appear in the next chapter and include summary tables that describe all command subsystems, syntax, parameter ranges, values, and response forms for possible command queries.

The next section, Sample Programs, will illustrate the SCPI command format and syntax with tested examples for typical time-keeping tasks performed via RS-232C serial data communication.

The section following the sample programs describes how to use a typical personal computer-based data communications program to automate the program examples as pre-programmed batch tasks you can call up quickly. This same section also mentions some very important programming considerations for using HP BASIC with the 5071A's SCPI commands and serial interface.

SCPI Command Conformance

The SCPI commands used in the 5071A are in conformance with the SCPI Standard Version 1990.0. The instruments SCPI command set consists of the following:

- Common Commands as defined in IEEE 488.2 - 1987.
- Subsystem commands as confirmed (and listed) in the SCPI standard. These are commands defined in table 5-2 as Std.
- Subsystem commands designated for the instrument in conformance with SCPI standards but not yet listed in the SCPI standard. These are the commands defined in table 5-2 as New.

Command Types

There are two types of 5071A program commands: IEEE 488.2 Common and SCPI. The SCPI commands control instrument functions while the IEEE 488.2 Common commands control and manage communications between the 5071A and a terminal or personal computer.

Common Command Format

The IEEE 488.2 standard defines the Common commands that perform functions like reset, self-test, status byte query, and identification. Common commands are four or five characters in length, always begin with the asterisk (*) character, and may include one or more parameters. The command keyword is separated from the first parameter by a space character. Some examples of common commands are:

```
*RST
*ESR?
*IDN?
```

SCPI Command and Query Format

SCPI commands perform functions like instrument setup, synchronization, adjusting epoch and reporting instrument-specific operating parameters. A subsystem command structure is a hierarchical structure that usually consists of a top level (or root) command, one or more lower-level commands, and their parameters. The following example shows part of a typical subsystem for an issued command and its associated query (?):

```
DIAGnostic:LOG:VERBosity <DISable|TERSe|VERBoSe|SERVice>
:VERBosity? DIS|TERS|VERB|SERV
```

DIAGnostic is the root command with :LOG and :VERBosity (?) the second level commands with command and response parameters.

Command Separator

A colon (:) always separates one command from the next lower-level command as shown here: `DIAGnostic:CURRent:CFIeld?`

Command Types***Abbreviated Commands***

The command syntax shows most commands as a mixture of upper and lower case letters. Upper case letters indicate the abbreviated spelling for the command. For shorter program lines, send the abbreviated form. For better program readability, you may send the entire command. The 5071A accepts either command form and is not case sensitive.

For example, if the command syntax shows DIAGnostic, then DIAG and DIAGNOSTIC are both acceptable forms. Other forms of DIAGnostic, such as DIAGN or DIAGNOST will generate an error. You may use upper or lower case letters. Therefore, DIAGNOSTIC, diagnostic, and DiAgNoStIc are all acceptable.

Implied Channel

Some commands contain channel numbers in square brackets: [1 | 2]. The brackets indicate that the same programming sequence can be used for both channels, one of which must be specified. If a channel number is not specified, it will default to 1.

Implied Commands

Implied commands appear in square brackets ([]) in the command syntax. (The brackets are not part of the command and are not sent to the instrument.) Suppose you send a second level command but do not send the preceding implied command. In this case, the instrument assumes you intend to use the implied command and responds as if you had sent it.

Examine the portion of the DIAGnostic subsystem shown below:

```
SOURce ]
      :PTIME
          [ :TIME ] <hour> , <minute> , <second>
          [ :TIME ]? [ MIN | MAX ] , [ MIN | MAX ] , [ MIN | MAX ]
```

The root command SOURce is an implied command (as is :TIME). To set the instruments time to 9:30 am, you can send either of the following command statements:

```
SOURce:PTIME:TIME 09,30,00
```

or

```
PTIME 09,30,00
```

Command Types

If a command is an implied form but can also accept channel numbers, the implied form pertains to channel 1 only. To switch channels, you must use the channel number in the command string. For example:

```
ROSC:FREQ2 5E6
```

Parameter Types

Table 4-1 contains explanations and examples of parameter and response types typically encountered in SCPI programming. These may be numeric, boolean, or discrete.

Table 4-1. Command Parameter and Response Types

Parameter Type	Examples and Explanations
Numeric	<p>Accepts all commonly used decimal representations of numbers with optional signs, decimal points and scientific notation: 123, 123E2, -123, -1.23E2, .123, 1.23E-2, 1.23000E-01</p> <p>Special cases include MIN and MAX as follows: MIN selects the minimum value available, and MAX selects the maximum value available.</p> <p>Queries on MIN or MAX return the associated value. All decimal types also accept MIN or MAX and can be queried with them to produce a numeric value.</p>
Boolean	Represents a single binary condition that is either true or false: 1 or ON, 0 or OFF.
Discrete	<p>Selects from a finite number of choices. These parameters use mnemonics to represent each valid setting. An example is the DIAGnostic: LOG:VERBosity<mode> command where mode can be DISable, TERSe, VERBoSe, or SERvice.</p>
Response Type	Explanations
<boolean>	Represents a single binary condition that is either true or false.
ASCII_string	Represents a series of ASCII characters of arbitrary length.
<NR1>	Represents integer numbers with an implied decimal point.
<NR2>	Represents floating point numbers with an explicit decimal point.
<NR3>	Represents floating point numbers with an explicit decimal point and an exponent.

Command Types***Optional Parameters***

Parameters shown within square brackets ([]) are optional parameters. (The brackets are not part of the parameter and are not sent to the instrument.) If you do not specify a value for an optional parameter, the instrument selects the most appropriate value.

Query Parameters

All selectable numeric parameters can be queried to return the minimum and maximum values that are capable of being set to by sending a MIN or MAX optional parameter after the ?. For example, consider the PTIME:MJDate? [MIN | MAX] command. If you send the command without specifying a parameter, the present PTIME:MJDate value is returned. If you send the MIN parameter, the command returns the minimum usable value. If you send the MAX parameter, the command returns the largest MJDate usable value. Be sure to place a space between the command and the parameter.

Linking Commands

To link IEEE 488.2 Common Commands with SCPI commands on the same line, use a semicolon between the commands. For example:

```
*RST;DIAG:CONT:RES?
```

Multiple SCPI commands with corresponding parameters can also be sent at the same time. Here, the first command is always referenced to the root node. Subsequent commands, separated by ;, are referenced to the same level as the previous command if no : is present immediately after the command separator. For example, sending

```
SOUR:ROSC:FREQ1 5.0E+6;ROSC:FREQ2 1E+7
```

is equivalent to sending:

```
SOUR:ROSC:FREQ1 5.0E+6
SOUR:ROSC:FREQ2 1E+7
```

The “:” must be present to distinguish another root level command. For example,

```
SYST:REM ON;:DIAG:CONT:RESET
```

is equivalent to sending:

```
SYST:REM ON
DIAG:CONT:RESET
```

Command Types

If the “:” in front of `DIAG` is omitted, the instrument assumes that you’ve sent `SYST:DIAG:CONT:RESET` and will generate an error.

***RST Reset Response**

The 5071A reset response (Initialization state) is the configuration acquired at program reset. Table 4-2 summarizes this state. Once a configuration has been saved, it will persist even if power is removed or until it is reprogrammed (via SCPI commands or through the front-panel menus).

Table 4-2. *RST Reset Conditions

Subsystem	Command/Parameter	State
DIAGnostic	:LOG:VERBosity	DISable
DISPlay	:ENABLE	ON
[SOURce]:PTIME	:SYNC	OFF
[SOURce]:ROSCillator	:STEer	0.0
SYSTem	:REMote	ON

The IEEE 488.2 *RST command returns the instrument to a specified state optimized for remote operation. Use *CLS to clear the status registers and the SCPI error queue.

Sample Program Commands

Several remote-operation task scenarios are provided that illustrate how to control the 5071A from a terminal with SCPI commands (Standard Commands for Programmable Instruments). The example programs cover the major time-keeping operations needed for remote control of the 5071A.

Each program contains several functions related to the overall task. The constituent functions are listed to the right of the corresponding program lines. You can use these function explanations to customize control programs for your own special needs.

The example programs are written with SCPI short-form notation. The full names, options, and parameters for these commands are contained in the SCPI Command Tree/Summary in Chapter 5 of this manual. A complete list of 5071A error messages including code numbers and causes is located at the end of Chapter 5.

Set Printer Log Verbosity to DISABLED For Example Programs in this Section

The programming examples provided must be run with the printer log verbosity set to DISABLED, otherwise the returned messages will differ from those presented in the examples.

Sample Program Commands**Status Monitoring Tasks*****Example Program 1 — Status Report Inquiry***

The commands you send are in BOLD, (followed by <CR><LF>) the 5071A's responses are in italics. If you make a mistake (i.e., generate an error # at the scpi prompt) type “*cls” followed by <CR><LF> (Return Line Feed).

Program Dialog**Task Function****SYST:PRINT?**

Request an operating status report.

*MJD 48587 21:03:42**CBT ID: 6-temp**Status summary: Operating normally**Power source: AC**Log status: Empty*

Freq Offset: 0e-15
RF amplitude 1: 20.2 %
Zeeman Freq: 39949 Hz
E-multiplier: 1870 V

Osc.control: -1.67 %
RF amplitude 2: 19.9 %
C-field curr: 12.137 mA
Signal Gain: 28.8 %

CBT Oven: 6.2 V
Osc. Oven: -8.8 V
HW Ionizer: 1.0 V
SAW Tuning: 3.5 V
87MHz PLL: -0.8 V
+12V supply: 12.3 V
+5V supply: 5.3 V

BT Oven Err: 0.00 C
Ion Pump 0.2 μA
Mass spec: 9.1 V
DRO Tuning: 6.8 V
μP clock PLL: 2.9 V
-12V supply: -12.4 V
Thermometer: 35.0 C

*scpi >****Example Program 2 — Print Log Request*****Program Dialog****Task Function****DIAG:LOG:PRINT?**

Print log (empty !)

*Log status: Empty**<scpi >*

Sample Program Commands**Instrument Control Tasks**

The commands you send are in BOLD, (followed by <CR><LF>) the 5071A's responses are in italics. If you make a mistake (i.e., generate an error # at the scpi prompt) type *cls followed by <CR><LF>.

Example Program 1 — Configuration

Program Dialog	Task Function
DIAG:STAT:GLOB? <i>"Operating normally"</i> <i>scpi ></i>	Request the operating status of the 5071A.
SYST:REM ON	Command the 5071A to enter Remote mode.
DIAG:CONT:RESET <i>scpi ></i>	Set/Reset the Continuous Operation light on the front panel.
SOUR:ROSC:FREQ1 5.0E+6 <i>scpi ></i>	Set Port 1 output to 5 MHz.
SOUR:ROSC:FREQ2 1.0E+7 <i>scpi ></i>	Set Port 2 output to 10 MHz.
SYST:SCON <i>scpi ></i>	Save this configuration in memory.

Example Program 2 — Synchronization and Time/Date Setup

Program Dialog	Task Function
SOUR:PTIM:SYNC FRONT <i>scpi ></i>	Synchronize to external pulse with front-panel sync input.
SOUR:PTIM:TIME 20,54,40 <i>scpi ></i>	Set time.
SOUR:PTIM:MJD 48587 <i>scpi ></i>	Set Modified Julian date.
SOUR:PTIM:SLEW 123.33425E-3 <i>scpi ></i>	Adjust Epoch with resolution to 50 ns.

Sample Program Commands***Example Program 3 — Leap Second Insertion***

Program Dialog	Task Function
SOUR:PTIM:LEAP:MJD 48621 <i>scpi</i> >	Set date of leap second.
SOUR:PTIM:LEAP:DUR 59 <i>scpi</i> >	Set time (show minute).
SOUR:PTIM:LEAP ON <i>scpi</i> >	Enable Leap second insertion.

Example Program 4 — Steering the Outputs

Program Dialog	Task Function
SOUR:ROSC:STE -1.23E-13 <i>scpi</i> >	Steer all outputs with a fractional offset of -1.23×10^{-13} .

Example Program 5 — Slewing the Clock

Program Dialog	Task Function
SOUR:PTIM:SLEW 0.5 <i>scpi</i> >	Adjust epoch: add one-half second.

Batch Processing for the Program Commands

This section provides information for automating the sample program commands presented in the previous section. HP/Agilent's AdvanceLink for Windows data communications program for the personal computer is discussed first. This is followed by some important considerations for using SCPI commands with HP BASIC on the HP 9000 Series 200/300 instrument controllers.

Command Scripts On a Personal Computer

You can use any terminal emulator program that supports scripting (batch file execution over a data-communications line) such as Agilent's AdvanceLink for Windows. The following procedure applies specifically to AdvanceLink for Windows and may also provide a generic plan useful with other popular Data Communications software for your Personal Computer.

- 1** Use an ASCII text editor to type in and name one of the example programs (or your own).
- 2** Exit the text editor and open Agilent's AdvanceLink for Windows on your Personal Computer.
- 3** Select the Script menu choice from the pull-down menus at the top of the screen.
- 4** Choose the Do Commands in File ... task.
- 5** Type in the name of the SCPI task file you entered previously as ASCII text.
- 6** Observe the successful completion of the script file by return of the scpi > prompt.

SCPI Considerations For HP BASIC

You can also use an HP 9000 Series 200/300 Instrument Controller with HP BASIC to operate the 5071A remotely. The following considerations require your attention as you attempt to utilize SCPI commands that follow protocols optimized for HP-IB parallel data transfer, status reporting, and SRQ polling.

SCPI on RS-232C

The SCPI protocol has been adapted to fit the communication requirements of the 5071A. On one hand this facilitates extremely convenient programming, as a serial terminal can be used. On the other hand, some complexities arise since full-duplex communication is usually required, data is in serial form, and no control lines are available. The most important features added to the SCPI protocol for serial operation are as follows:

- Each character in the command string sent to the instrument is echoed back to the sender immediately.
- Any command must be terminated with suitable characters.
- Following the execution of any command, the instrument outputs a prompt sequence, indicating that it is ready for more commands.
- The prompt sequence indicates whether an operational or communication error has occurred while attempting to execute the command.
- The error prompt is removed by reading the error.
- If the command sent to the instrument generates a response, the response is emitted as soon as it is ready.

More details of the serial protocol can be found in Chapter 5, “Serial-Port Command/Printer Interface.”

An IEEE-488.2 to RS232 converter can also be used to drive the 5071A from an IEEE-488.2 interface. The converter must provide buffering for the incoming serial data since the serial port of the 5071A uses full-duplex operation.

Full-Duplex Communication

The normal mode of serial communication for the 5071A is full-duplex. The instrument echoes the command sequence, thus emitting characters while others are being received. If an instrument controller is to be used to control the 5071A, it must buffer incoming data while sending data. If the loss of data-rate is acceptable, it is possible to suppress full-duplex operation using the XON/XOFF protocol. In the following example, full-duplex operation is assumed.

Printer-Mode Output

If you want to monitor instrument operation with a printer, the 5071A has an operating mode that automatically sends operational or warning messages out the serial port to a printer (or terminal).

NOTE

These “unprompted” messages may be inconvenient when the instrument is controlled by a computer, and can be suppressed with the CONFIG:LOG DISABLE configuration command line.

The messages can then be obtained from the instruments non-volatile log on demand.

Example Program

The following HP BASIC program demonstrates some of the points discussed. The program segment consists of a Main program and Defined Function. The main program contains subroutines for setting up a 98626 or 98644-equivalent serial interface, and establishing the buffering required for full-duplex operation.

The transmitted messages are entered from the keyboard and passed to the defined function FNTalk\$ as the string Output\$. The function outputs the properly terminated string and returns the instruments reply. The operation of the program can be understood from the comments which are included.

For details see the HP BASIC Manual (part number 98613-90022), Interfacing Techniques Vol 1: General Topics. The program works on workstations with HP BASIC 5.13 or later, and with HP BASIC/UX 6.2.

```
10 Prog_des$="example"
20 Ver_date$="01/22/92"
30 !
40 COM /Io/ In_buff$[2048] BUFFER,Out_buff$[80] BUFFER,@In,@Out
50 INTEGER Isc,Baud,Type,Quit_flag
60 DIM Output$[80],Type$[16],Return$[64],Op_sys$[6]
70 !
80 Isc=9
90 Baud=2400
100 !Op_sys$="RMB/WS" !Un-comment the appropriate
110 Op_sys$="RMB/UX" !operating system
120 !
130 CLEAR SCREEN
140 CONTROL 1,12;1
150 PRINT TABXY(1,1)
160 GOSUB Ser_setup
170 GOSUB Bfr_setup
180 !
190 WHILE NOT Quit_flag
200 LINPUT "Enter command string ('quit' to stop)", Output$
210 IF LWC$(Output$)="quit" THEN
220 Quit_flag=1
230 ELSE
240 OUTPUT 1;FNTalk$(Output$);
250 END IF
260 END WHILE
270 GOSUB Bfr_cancel
280 CONTROL 1,12;2
290 STOP
300 !
310 Ser_setup:!
```

Chapter 4 Remote Operation and Programming

Batch Processing for the Program Commands

```

320 STATUS Isc,0;Type           !This sub-routine finds the
330 SELECT Type                 !interface identity at the
340 CASE 2                       !chosen Select Code.  If
350   Type$="98626"             !suitable, it calls the
360   GOSUB Ifc_set             !'Ifc_set' sub-routine to
370 CASE 66                     !set appropriate register
380   Type$="98644"             !values.  Types 98626 and
390   GOSUB Ifc_set             !98644 work are supported.
400 CASE ELSE
410   PRINT "  The interface at ISC "&VAL$(Isc)&" is not
      suitable"
420   STOP
430 END SELECT
440 RETURN
450 !
460 Ifc_set:!
470 CONTROL Isc,0;1             !This sub-routine sets the
480 CONTROL Isc,3;Baud          !interface for operation at
490 CONTROL Isc,4;3             !the selected baud rate with
500 CONTROL Isc,5;1             !8 data bits, HDSK disabled.
510 IF Op_sys$="RMB/WS" THEN
520   CONTROL Isc,12;176
530 END IF
540 PRINT "  "&Type$&" Serial interface at ISC "&VAL$(Isc)&" set
      up: "&VAL$(Baud)&", 8, None"
550 RETURN
560 !
570 Bfr_setup:                  !This sub-routine
580 ASSIGN @Ser_in TO Isc        !sets up buffers
590 ASSIGN @Ser_out TO Isc       !to support full-
600 ASSIGN @In TO BUFFER In_buff$;FORMAT ON !duplex serial
610 ASSIGN @Out TO BUFFER Out_buff$;FORMAT ON!communication.
620 TRANSFER @Ser_in TO @In;CONT !The FORMAT ON
630 TRANSFER @Out TO @Ser_out;CONT! !option expects
640 RETURN                       !ASCII data.
650 !
660 Bfr_cancel:!                !This sub-routine
670 ABORTIO @Ser_out             !cancels buffers
680 ABORTIO @Ser_in             !previously setup in
690 RETURN                       !order to shut down.
700 !
710 END
720 !-----
730 DEF FNTalk$(Output$)
740   COM /Io/ In_buff$[2048] BUFFER,Out_buff$[80] BUFFER,
      @In,@Out
750   DIM Input$[2048],A$[1],Term$[1]
760   INTEGER Q,Prompt_flag,Done
770   REAL Timeout
780   Term$=CHR$(62)
790   Timeout=10

```

Chapter 4 Remote Operation and Programming

Batch Processing for the Program Commands

```
800      !
810      !
820      ON DELAY Timeout,15 GOTO Hang!
830      STATUS @In,4;Q           !Set timeout and remove
840      WHILE Q                 !any remaining characters
850          ENTER @In USING "#,A";A$      !from input buffer
860          STATUS @In,4;Q
870      END WHILE
880      !
890      OUTPUT @Out;Output$      !Put data in output buffer
900      !OUTPUT @Out;Output$&"scpi > "; !Loopback test version
910      !
920      WHILE NOT Prompt_flag
930          STATUS @In,4;Q           !The input buffer unloads
940          IF Q THEN               !one character at a time.
950              ENTER @In USING "#,A";A$      !Each character is added
960              Input$=Input$&A$          !to the input string and
970              IF A$=Term$ THEN          !checked for a match with
980                  Prompt_flag=1         !the termination character
990              END IF                 !When the termination
1000             END IF                !appears, unloading stops.
1010         END WHILE                !After the termination
1020                                     !character, one more
1030     WHILE NOT Done                !character is unloaded
1040         STATUS @In,4;Q           !and added to the
1050         IF Q THEN                !string.
1060             ENTER @In USING "#,A";A$      !
1070             Input$=Input$&A$
1080             Done=1
1090         END IF
1100     END WHILE
1110     OFF DELAY
1120     GOTO Exit
1130     !                             !I/O has timed out.
1140 Hang: !
1150     IF LEN(Input$) THEN
1160         Input$="< "&Input$&" (prompt sequence not received
            before timeout)"
1170     ELSE
1180         Input$="< I/O timeout (no reply from serial port)"
1190     END IF
1200     !
1210 Exit: !
1220     RETURN Input$
1230 FNEN
```

Tips on Using the RS-232C Port on the 5071A

The RS-232C port on the 5071A rear panel is very useful for controlling the instrument and gathering data. However, communication via the RS-232C is not always a connect-and-go process. Until recently, there were many different vendors producing differing handshaking protocols, data rates, and wiring connections.

Because of the myriad of possible hardware, system, and software combinations, there are many ways to incorrectly set up and connect the RS-232C and potentially lock-up the system. This condition usually appears as non-sensible characters being received, or no communication at all.

This section is intended to give you a summary of how some RS-232C lock-ups occur and how best to clear them.

Keypad Lock-Ups: Why do they occur and how are they cleared?

Description

First, make sure the padlock symbol does not appear in the LCD display. If so, the 5071A is locked via the SCPI command SYST:REM ON and must be unlocked before some front panel operations can be accepted. Refer to this manual for instructions on how to unlock the front panel.

If this is not the case, the 5071A front panel can appear to be frozen (no key presses accepted) if it is communicating with another serial device via the RS-232C and receives a data holdoff from that device. There are two types of holdoffs: One is the XON/XOFF (software) protocol, and the other is the DSR (Data Set Ready) line (hardware). Either of these can be used by printers or terminals. The 5071A is capable of understanding both.

XON/XOFF

When a connected terminal or printer uses the XON/XOFF protocol the 5071A will hold off further data transmission when an XOFF (Control-S) is received.

This usually happens when a terminal/printer buffer is full or if a printer is out of paper.

The 5071A will then wait until it receives an XON signal (Control-Q) before resuming the transmission. The 5071A will wait indefinitely for an XOFF to clear.

Example:

One example of this is when the 5071A is printing the Status Log and the connected printer runs out of paper. If the printer uses the XON/XOFF protocol, it will send an XOFF (Control-S) that will stop the flow of data from the 5071A. The front panel is now busy waiting for an XON (Control-Q) to resume printing.

Solution:

If the front panel is locked in a print operation to the Serial Port, the solution is to correct the cause of the problem. For example, add more paper to the printer.

If the printer is no longer connected but a terminal is available, ensure that the terminals Baud Rate, Parity, Data Bits, and Stop Bits are consistent with the 5071A, then send a Control-Q from the terminal keyboard. This should result in the remaining data from the 5071A being sent to the terminal and thereby clear the problem.

DSR

The DSR signal acts exactly like the XON/XOFF protocol, but instead of being implemented in software it is done in hardware. The DSR line (pin 6) is one of the three signals used by the 5071A in RS-232C communications (the other lines are Data Transmit and Data Receive). When DSR is false (negative voltage), data transmission from the 5071A will stop until the DSR is true again (positive voltage). If this line is not connected to any signal, then DSR is pulled positive inside the 5071A.

Example:

One example of how DSR can stop front panel operation is if the wrong cable is used, forcing a negative signal on the DSR (pin 6). If under these conditions, an INFO PRINT command is issued from the front panel, the 5071A will be busy until the DSR returns to a positive voltage.

Solution:

One way to find out if there is a DSR problem is to remove the Serial Port cable. The DSR will be pulled back to a positive voltage and the front panel should re-activate. As long as there are no other reasons for halting the data (e.g. XOFF) the 5071A will send data to the RS-232C port even when there is no device attached.

Using Ctrl-Q in Programs

Because some hang-ups could occur without user intervention during program operations, it may be useful to add a routine that automatically sends a Ctrl-Q (XON) to the 5071A. This can be triggered by a timeout that monitors the RS-232 for incoming data.

Chapter 4 Remote Operation and Programming
Tips on Using the RS-232C Port on the 5071A

Chapter Contents

This chapter describes the SCPI and IEEE 488.2 commands and error messages applicable to the 5071A Primary Frequency Standard. Software interface and status reporting operation are also discussed.

The chapter is organized as follows:

- 5071A Command Summary page 5-3
 - IEEE 488.2 Common Commands page 5-3
 - SCPI Commands page 5-5
- Description of SCPI Commands page 5-9
 - Diagnostic Commands page 5-9
 - Display Commands page 5-14
 - Precision Time (Date and Time) Commands page 5-15
 - Reference Oscillator Commands page 5-19
 - STATus Monitoring Commands page 5-21
 - System Commands page 5-26
- Status Reporting page 5-30
- Rear-Panel Status Output Operation page 5-33
 - Status Output Programming page 5-33
 - Example 1 — Programming the Status Output for a Single True Condition page 5-34
 - Example 2 — Programming the Status Output for Multiple True and False Conditions page 5-34
- Serial-Port Command/Printer Interface page 5-35
 - Mode Selection page 5-35
 - Pacing page 5-35
 - The Prompt page 5-36
 - End-Of-Line Characters page 5-36
- Error Messages/Codes page 5-37

5071A Command Summary

This section summarizes both the IEEE 488.2 Common and 5071A SCPI (Standardized Commands for Programmable Instruments) commands in tabular format. IEEE 488.2 commands appear first followed by SCPI commands. The SCPI commands used in this instrument are in conformance with the SCPI Standard Version 1990.0. The SCPI command set consists of the following:

- Common commands as defined in IEEE 488.2-1987.
- Subsystem commands as confirmed (and listed) in the SCPI Standard. These are the commands defined in Table 5-2 as Std.
- Subsystem commands designed for the instrument in conformance with SCPI Standards but not yet listed in the SCPI Standard. These are the commands defined in Table 5-2 as New.

The IEEE 488.2 commands are summarized first (Table 5-1) followed by SCPI commands (Table 5-2). Details of all 5071A SCPI commands can be found in the SCPI Subsystem Commands section following the SCPI Command summary.

The SCPI command format, syntax, parameter and response types, and Common command formats are explained in Chapter 4 following the programming overview.

IEEE 488.2 Common Commands

Table 5-1 lists Common commands by mnemonic, name and function. More information concerning the operation of IEEE 488.2 status reporting commands and structure can be found in the Status Registers section of this chapter following the SCPI Subsystem Command descriptions. Detailed explanations of the 5071A Common Commands can be found in ANSI/IEEE Std. 488.2-1987, IEEE Standard Codes, Formats, Protocols and Common Commands.

5071A Command Summary**Table 5-1. IEEE 488.2 Common Commands**

Mnemonic	Command Name	Function
*CLS	Clear Status	Clears the status registers and error queue
*ESE	Standard Event Status Enable	Sets the Standard Event Status Enable Register bits
*ESE?	*ESE Query	Returns Standard Event Status Enable Register contents
*ESR?	Event Status Register Query	Returns Event Status Register Contents.
*IDN?	Identification Query	Returns Instrument identification string
*OPC	Operation Complete	(accepted but ignored)
*OPC?	Operation Complete Query	(always returns +1)
*RST	Reset	Reset (See *RST Response: Table 4-2.)
*SRE	Service Request Enable	Set service request enable register.
*SRE?	*SRE Query	Returns contents of SRE register
*STB?	Status Byte Query	Returns summary status byte
*TST?	Self-Test Query	Same as DIAG:TEST? –1 (runs self tests)
*WAI	Wait for completion	(accepted but ignored)

5071A Command Summary

SCPI Commands

Table 5-2 lists SCPI commands by keyword, syntax, parameter and response form and provides brief explanatory comments.

Table 5-2. SCPI Command Summary

Command	Parameter Form	Response Form	Comment
DIAGNOSTIC COMMANDS			
DIAGnostic:CBTSerial?	—	<string>	Returns CBT serial number.
DIAGnostic:CONTinuous:RESet	—		Reset Continuous Operation light.
DIAGnostic:CONTinuous: [:STATe]?		<OFF ENAB ON>	Returns Continuous Operation status.
DIAGnostic:CURRent :BEAM?	—	<NR3>	Returns beam current setpoint.
DIAGnostic:CURRent:CFieLd?	—	<NR3>	Returns C-field current.
DIAGnostic:CURRent :PUMP?	—	<NR3>	Returns ion-pump current.
DIAGnostic:GAIN?	—	<NR3>	Returns signal gain.
DIAGnostic:LOG:CLEar	—		Clears log entries.
DIAGnostic:LOG :COUNT?	—	<NR1>	Returns number of log entries.
DIAGnostic:LOG :PRINt?	—	<string>	Prints log entries.
DIAGnostic:LOG[:READ]?	[<numeric_value>]	<string,string>	Returns log entry.
DIAGnostic:LOG:VERBosity	<DISable TERSe VERBose SERVice>		Selects printer log-report detail.
DIAGnostic:LOG:VERBosity?	—	DIS TERS VERB SERV	Returns printer-logging detail level.
DIAGnostic:RFAMplitude?	—	<NR3,NR3>	Returns RF amplitudes.
DIAGnostic:STATus[:GLOBal]?	—	<string>	Returns summary status.
DIAGnostic:STATus:SUPPLY?	—	AC DC BATT LOW	Returns power supply status.
DIAGnostic:TEMPerature?	—	<NR3>	Returns ambient temperature.
DIAGnostic:TEST?	<numeric_value>	<0 1>	Runs Diagnostics (standby mode).
DIAGnostic :VOLTage:COVen?	—	<NR3>	Returns CBT oven Volts.
DIAGnostic :VOLTage :EMULTiplier?	—	<NR3>	Returns Electron multiplier Volts.

Chapter 5 Command Reference
5071A Command Summary

Table 5-2. SCPI Command Summary (Continued)

Command	Parameter Form	Response Form	Comment
DIAGnostic :VOLTage:HWIonizer?	—	<NR3>	Returns Hot wire ionizer Volts.
DIAGnostic :VOLTage:MSpec?	—	<NR3>	Returns Mass spectrometer Volts.
DIAGnostic :VOLTage:PLLoop?	—	<NR3, NR3, NR3, NR3>	Returns Phase-Lock Loop Volts.
DIAGnostic :VOLTage:ROSCillator?	—	<NR3>	Returns Quartz OSC Mon. Volts.
DIAGnostic :VOLTage:SUPply?	—	<NR3, NR3, NR3, NR3>	Returns Power Supply Volts.
DISPLAY COMMANDS			
DISPlay:ENABLE	<OFF 0 ON 1>		Sets the Clock Display ON or OFF.
DISPlay:ENABLE?		<0 1>	Returns Clock display status.
PRECISION TIME (DATE AND TIME) COMMANDS			
[SOURce]:PTIME[:TIME]	<hour>, <minute>, <second>		Sets 24-hour time.
[SOURce]:PTIME[:TIME]?	[MIN MAX, MIN MAX, MIN MAX]	<NR1, NR1, NR1>	Returns 24-hour time.
[SOURce]:PTIME:MJDate	<numeric_value>		Sets modified Julian date (MJD).
[SOURce]:PTIME:MJDate?	[MIN MAX]	<NR1>	Returns the MJD.
[SOURce]:PTIME:LEAPsecond:DURation	<numeric_value>		Sets Leap second minute duration.
[SOURce]:PTIME:LEAPsecond:DURation?	[MIN MAX]	<NR1>	Returns Leap second minute duration.
[SOURce]:PTIME:LEAPsecond:MJDate	<numeric_value>		Sets MJD for a scheduled leapsecond (LPS).
[SOURce]:PTIME:LEAPsecond:MJDate?	[MIN MAX]	<NR1>	Returns MJD scheduled leapsecond (LPS).
[SOURce]:PTIME:LEAPsecond[:STATe]	<OFF 0 ON 1>		Sets or cancels a scheduled LPS.
[SOURce]:PTIME:LEAPsecond[:STATe]?		<0 1>	Returns status of a scheduled LPS.
[SOURce]:PTIME:SLEW	<numeric_value>		Adjusts clock Epoch.
[SOURce]:PTIME:SLEW?	[MIN MAX]	<NR3>	Returns MIN/MAX acceptable Slew-value.

Chapter 5 Command Reference
5071A Command Summary

Table 5-2. SCPI Command Summary (Continued)

Command	Parameter Form	Response Form	Comment
[SOURce]:PTIMe:STANdby	<OFF 0 ON 1>		Sets/resets Standby mode.
[SOURce]:PTIMe:STANdby?		<0 1>	Returns Standby mode status.
[SOURce]:PTIMe:SYNChronization	<OFF FRONT REAR>		Arms selected Sync port.
[SOURce]:PTIMe:SYNChronization?		<OFF FRON REAR>	Returns armed Sync port, if any.
REFERENCE OSCILLATOR COMMANDS			
[SOURce]:ROSCillator:CONTRol	<numeric_value>		Sets OSC tune voltage (in Standby).
[SOURce]:ROSCillator:CONTRol?	[MIN MAX]	<NR3>	Returns OSC tuning voltage.
[SOURce]:ROSCillator:STEEr	<numeric_value>		Sets fractional frequency offset.
[SOURce]:ROSCillator:STEEr?	[MIN MAX]	<NR3>	Returns set fractional frequency offset.
[SOURce]:ROSCillator:FREQuency[1 2]	<frequency>		Sets selected Output-port Hz.
[SOURce]:ROSCillator:FREQuency[1 2]?	[MIN MAX]	<NR3>	Returns Output-port Hz.
[SOURce]:ROSCillator:MVOLTage?		<NR3>	Returns OSC-oven monitor voltage.
STATUS MONITORING COMMANDS			
STATus:OPERation[:EVENT]?		<NR1>	Returns/clears OEReg contents.
STATus:OPERation:CONDition?		<NR1>	Returns OCREg contents.
STATus:OPERation:ENABLE	<numeric_value>		Sets OEReg to specified value.
STATus:OPERation:ENABLE?		<NR1>	Returns OEReg contents.
STATus:OPERation:NTRansition	<numeric_value>		Sets NTRReg to specified value.
STATus:OPERation:NTRansition?		<NR1>	Returns NTRReg contents.
STATus:OPERation:PTRansition	<numeric_value>		Sets PTRReg to specified value.
STATus:OPERation:PTRansition?		<NR1>	Returns PTRReg contents.

Chapter 5 Command Reference
5071A Command Summary

Table 5-2. SCPI Command Summary (Continued)

Command	Parameter Form	Response Form	Comment
STATus:QUESTionable[:EVENT]?		<NR1>	Returns/clears QEReg contents.
STATus:QUESTionable:CONDition?		<NR1>	Returns QCReg contents.
STATus:QUESTionable:ENABle	<numeric_value>		Sets QEReg to specified value.
STATus:QUESTionable:ENABle?		<NR1>	Returns QEReg contents.
STATus:QUESTionable:NTRansition	<numeric_value>		Sets NTRReg to specified value.
STATus:QUESTionable:NTRansition?		<NR1>	Returns NTRReg contents.
STATus:QUESTionable:PTRansition	<numeric_value>		Sets PTRReg to specified value.
STATus:QUESTionable:PTRansition?		<NR1>	Returns PTRReg contents.
STATus:PRESet			Resets Control Registers/clears Status Output.
SYSTEM COMMANDS			
SYSTem:ERRor?		<NR1,string>	Returns error numbers/messages
SYSTem:KEY	<numeric_value>		Inserts keycode in keypress queue.
SYSTem:KEY?	[MIN MAX]	<NR1>	Returns last keypress code.
SYSTem:PRINt?		<ASCII_string>	Prints status report.
SYSTem:REMote	<OFF 0 ON 1>		Enables/disables remote operation.
SYSTem:REMote?		<0 1>	Returns remote operation status.
SYSTem:SCONfiguration			Saves instrument configuration.
SYSTem:TIME	<hours>,<minutes>,<seconds>		Sends SOUR:PTIM:TIME.
SYSTem:TIME?	[MIN MAX, MIN MAX, MIN MAX]	<NR1,NR1, NR1>	Returns 24-hour time.
SYSTem:VERSion?		<NR2>	Returns SCPI Version number.

Description of SCPI Commands

This section describes the SCPI commands for the 5071A Primary Frequency Standard. The commands are grouped by functionality and are presented in alphabetical order with their group. See Table 5-2 for a summary of each SCPI command.

Diagnostic Commands

The DIAGnostic commands provide access to the instrument's internal operating parameter values, event log entries, and internal self-tests.

DIAGnostic:CBTSerial?

This query returns the serial number of the installed CBT (Cesium-Beam tube). If the CBT ROM is faulty or unreadable, Factory Default returns.

Returned format = <string quoted>.

DIAGnostic:CONTinuous:RESet

This command resets the Continuous Operation light (illuminates continuously) if the instrument has triggered its warning mode. The 5071A must be in REMote mode to execute this command. If DIAG:CONT? is OFF, sending :CONT:RESet will generate error +202, "Valid only when operating normally".

The function of this command is not affected by *RST.

NOTE

If the instrument's state is "Warning", execution of this command changes it to "Operating normally". If a warning condition still exists, the instrument re-enters the Warning state immediately. Otherwise, the warning is cleared.

DIAGnostic:CONTinuous: [:STATE]?

This query returns Continuous Operation status.

Response format = OFF | ENAB | ON, defined as follows:

- OFF - Continuous Operation is neither enabled or reset,
- ENABle - Continuous Operation may be reset: Light flashing, or
- ON - Continuous Operation reset has occurred: Light On.

DIAGnostic:CURRent :BEAM?

This query returns the beam current setpoint in amperes.

Response format = <NR3>, precision = 1×10^{-9} A.

DIAGnostic:CURRent:CFieLd?

This query returns C-field current-setpoint value in amperes.

Response format = <NR3>, precision = 1×10^{-6} A.

DIAGnostic:CURRent :PUMP?

This query returns the ion pump current in amperes.

Response format = <NR3>, precision = 2×10^{-7} A.

DIAGnostic:GAIN?

This query returns counter signal gain as fraction of full-scale value.

Response format = <NR3>, precision = 1×10^{-3} .

DIAGnostic:LOG:CLEAr

This command purges all event log entries.

The 5071A must be in REMote mode to execute this command. This command is not affected by *RST and does not have a query.

DIAGnostic:LOG :COUNT?

This query returns the number of entries in the log as an integer. (If the log has been deleted, this query returns a negative value.)

Response format = <NR1>.

DIAGnostic:LOG :PRINT?

This query prints the entire contents of the event log. (Equivalent to the front panel "LOG PRINT" command.)

Response format = <arbitrary ASCII>

DIAGnostic:LOG[:READ]? [<numeric_value>]

This query returns the time stamp and text of the most recent unread log entry if no parameter is supplied; otherwise, it returns the specified log entry.

Response format = <string quoted, string quoted>.

Description of SCPI Commands

DIAGnostic:LOG:VERBosity DISable|TERSe|VERBose|SERVice

This command specifies the log stream events actually sent to the serial port.

The 5071A must be in REMote mode to execute this command.

The following four parameters of the DIAGnostic:LOG:VERBosity command allow you to select the log stream events that will be sent to the serial port:

- DISable prevents messages from being echoed to the serial port.
- TERSe causes only fatal errors to be echoed to the serial port.
- VERBose echoes all progress information and user events.
- SERVice adds detailed power-on/warm-up events to VERBose content.

The VERBosity setting has no effect on which messages are saved in non-volatile log. It only specifies which messages echo to the serial port unrequested.

DIAGnostic:LOG:VERBosity?

This query reports the active setting for log verbosity.

Return values = DIS, TERS, VERB, or SERV, (discussed above).

DIAGnostic:RFAMplitude?

This query returns RF Attenuator setpoints as fraction of full-scale.

Response format = <NR3, NR3>, precision = 1×10^{-3} .

DIAGnostic:STATus[:GLOBal]?

This query returns instrument's summary status message.

Response format = <string quoted>.

DIAGnostic:STATus:SUPPLY?

This query returns a power supply status indication.

Response format = AC | DC | BATT | LOW, defined as follows:

- AC - operating from ac power.
- DC - operating from auxiliary dc power.
- BATT - operating from internal battery backup.
- LOW - internal supply voltages below nominal.

DIAGnostic:TEMPerature?

This query returns ambient temperature sensed within the instrument in Celsius.

Response format = <NR3>, precision = 0.1° C, accuracy = ± 2.5° C

DIAGnostic:TEST? <numeric_value>

This query executes the diagnostic test specified by the supplied parameter.

The 5071A must be in Standby mode or Fatal error state to successfully execute this command, otherwise error message +203 “Valid only in standby” returns.

Response format = <boolean> (0: tests passed, or 1: tests failed).

The available test parameters and corresponding functions are:

- 1. Execute tests 0 through 17
- 0. Cbt board register test
- 1. Cbt board thermistor window test
- 2. Cbt board thermistor test
- 3. Cbt board Cesium oven test
- 4. Cbt board hot wire ionizer test
- 5. Cbt board mass spectrometer test
- 6. Cpu board RTDS test
- 7. Cpu board phase lock loop test
- 8. DDFS board register test
- 9. DDFS board and 87 MHz module tuning voltage test
- 10. DDFS board 9.2 GHz module tuning voltage test
- 11. Servo board register test
- 12. Servo board DAC time-out test
- 13. Interface board register test
- 14. Interface board Analog bus test
- 15. Pps board register test
- 16. Pps board interrupt test
- 17. Power logic check

DIAGnostic :VOLTage:COven?

This query returns the Cesium oven heater voltage.

Response format = <NR3>, precision = 0.1 V.

DIAGnostic :VOLTage :EMULtiplier?

:This query returns the electron multiplier voltage setpoint.

Response format = <NR3>, precision = 1 V.

DIAGnostic :VOLTage:HWIonizer?

This query returns the hot wire ionizer voltage setpoint.

Response format = <NR3>, precision = 1×10^{-1} V.

DIAGnostic :VOLTage:MSpec?

This query returns the mass spectrometer voltage setpoint.

Response format = <NR3>, precision = 1×10^{-1} V.

DIAGnostic :VOLTage:PLLloop?

This query returns tuning voltages for each of four phase locked loops: 9.2 GHz, 640 MHz, 87 MHz, 9 MHz.

Response format = <NR3, NR3, NR3, NR3>, precision = 1×10^{-1} V.

DIAGnostic :VOLTage:ROSCillator?

This query is equivalent to “[SOURce:]ROSCillator:MVOLTage?” See [SOURce:]ROSCillator:MVOLTage?

DIAGnostic :VOLTage:SUPPLY?

This query returns voltages from the +5, +12, and -12 volt power supplies.

Response format = <NR3, NR3, NR3>, precision = 1×10^{-1} V.

Display Commands

The DISPlay command turns the front-panel LED clock display ON or OFF.

DISPlay:ENABle OFF|0|ON|1

This command enables or disables the LED clock display. The display will illuminate if the time has been set.

The 5071A must be in REMote mode to execute this command.

REMote mode can be set ON by sending *RST.

The available parameters are:

OFF|0 - turns the display OFF, or

ON|1 - turns the display ON.

:DISPlay:ENABle?

This query returns the LED clock display status as ON or OFF (see above).

The clock display is ON if enabled and time has been set.

Response format <0 or 1>

Returns 1 if clock display is ON, 0 if display clock is OFF.

Precision Time (Date and Time) Commands

The [SOURce]:PTIME commands provide the most-important time keeping functions for the 5071A. These functions include commands for:

- Setting Time and Date
- Adjusting, scheduling, and executing Leap-second insertion
- Adjusting Epoch
- Setting operating mode
- Synchronizing 1pps outputs

PTIME[:TIME] <hour>,<minute>,<second>

This command sets time in 24-hour format (SCPI standard).

The 5071A must be in REMote mode to execute this command.

Requires three parameters: hours, minute, and second.

Entered values are rounded to integer.

The maximum range limits are 23, 59, 59, respectively.

The function of this command is not affected by *RST.

PTIME[:TIME]? [MIN|MAX, MIN|MAX, MIN|MAX]

This query returns time in 24-hour format (SCPI Std) as hours, minute, second, or minimum-maximum range-limit values.

Response format = <NR1, NR1, NR1>, precision = 1 s.

PTIME:MJDate <numeric_value>

This command sets the Modified Julian date to the specified value.

The 5071A must be in REMote mode to execute this command.

One parameter is required, range = 0 to 99999.

The function of this command is not affected by *RST.

PTIME:MJDate? [MIN|MAX]

This query returns the instrument's current MJD.

If not set, the date starts at zero and increments at the instrument's transition for midnight.

Response format = <NR1>.

PTIME:LEAPsecond:DURation <numeric_value>

This command programs the length of the minute preceding a scheduled leap second.

If no leap second is pending, duration is active when STATE is set ON.

If a leap second is pending, this command changes the scheduled duration by canceling the prior leap second and scheduling a new one with the specified duration.

The function of this command is not affected by *RST.

PTIME:LEAPsecond:DURation? [MIN|MAX]

This query indicates the duration of the minute preceding a pending leap second or minimum-maximum range-limit values.

If none is pending, the last specified value for DURation returns.

PTIME:LEAPsecond:MJDate <numeric_value>

This command programs the MJD for a scheduled leap second with the supplied parameter.

One parameter is required (MJD), range = 0 to 99999.

If no Leap second is pending, this date is active when STATE is ON.

If a leap second is pending, this command changes the scheduled duration by canceling the old leap second and scheduling a new one with the specified duration.

The function of this command is not affected by *RST.

PTIME:LEAPsecond:MJDate? [MIN|MAX]

This query indicates the MJD of any pending leap second or minimum-maximum range-limit values.

If none is pending, the last specified value of MJD or the present MJD, (whichever is greater) returns.

Description of SCPI Commands

PTIME:LEAPsecond[:STATe] OFF|0|ON|1

This command activates or cancels a programmed leap second.

When STATe is turned ON, a leap second is scheduled for the last specified values of DURation and MJDate.

The function of this command is not affected by *RST.

PTIME:LEAPsecond[:STATe]?

This query indicates whether a leap second is pending.

Response format = <0 or 1>

Returns 1 if pending, 0 if none pending.

PTIME:SLEW <numeric_value>

This command adjusts the epoch of the clock with the supplied parameter.

The 5071A must be in REMote mode to execute this command.

One parameter is required, accepts “S” suffix.

Parameter range = -0.5 S to 0.5 S., precision = 50 ns.

This is an event.

The function of this command is not affected by *RST.

PTIME:SLEW? MIN|MAX

This query returns the smallest and largest slew value which can be used.

Response format = <NR3>.

PTIME:STANdby OFF|0|ON|1

This command enables or disables STANDBY mode.

The 5071A must be in REMote mode to execute this command.

Disabling standby initiates normal operation, if possible. (This command is equivalent to the 5061B “cesium off” switch.)

The function of this command is not affected by *RST.

PTIME:STANdby?

This query returns 1 if instrument is in standby, 0 otherwise.

Response format <0 or 1>

Returns 1 if in standby, 0 if not in standby.

PTIME:SYNChronization OFF|FRONt|REAR

This command arms the specified sync port with the supplied parameter.

The 5071A must be in REMote mode to execute this command.

Arming terminates when:

- canceled from the command interface,
- a valid sync pulse is received at the armed port, or
- after 1-1/2 seconds has elapsed.

Examine the relative timing of the pulses to determine which event has occurred.

The function of this command is OFF at *RST.

The available parameters are:

- OFF — Turns off either Front or Rear Sync Input port connectors.
- FRONt — enables the Front-panel Sync Input port connector.
- REAR — enables the Rear-panel Sync Input port connector.

PTIME:SYNChronization?

This query indicates which sync port is armed, if any.

Response format = OFF | FRON | REAR.

Reference Oscillator Commands

The [SOURce]:ROSCillator commands provides more advanced time keeping functions for the 5071A. These functions increase the flexibility of the 5071A by providing a means of:

- setting reference oscillator tuning voltage,
- setting fractional frequency offsets,
- programming output-port frequency, and
- checking the monitor voltage for the ovenized oscillator.

ROSCillator:CONTRol <numeric_value>

This command controls the reference oscillator tuning voltage as a signed fraction of full scale with the supplied parameter.

The 5071A must be in REMote mode to execute this command.

This command requires that PTIME:STANdby is ON for successful completion; otherwise, the command is ignored.

Precision of control = one part in 32767.

Range = $\pm 3.3 \times 10^{-7}$ in frequency.

ROSCillator:CONTRol? [MIN|MAX]

This query returns the reference oscillator frequency control setpoint as a signed fraction of full scale or minimum-maximum acceptable range limits.

Response format = <NR3>, precision = 1×10^{-4} or better.

ROSCillator:STEEr <numeric_value>

This command introduces a fractional frequency offset in the output frequencies with the supplied parameter.

The 5071A must be in REMote mode to execute this command.

The instrument maintains servo lock to the Cesium resonance.

Parameter range = -1×10^{-9} to $+1.0 \times 10^{-9}$.

The function of this command is set to 0.0 by *RST.

ROSCillator:STEEr? [MIN|MAX]

This query returns the active value of fractional frequency offset or minimum-maximum acceptable range limits.

Response format = <NR3>, precision = 1×10^{-15} .

ROSC:FREQuency[1|2] <frequency>

This command sets the output frequency of the indicated port with the supplied parameter.

The 5071A must be in REMote mode to execute this command.

The frequency parameter is 5×10^6 or 10×10^6 Hz.

Values are rounded to the nearest valid setting, unless out of range.

The function of this command is not affected by *RST.

ROSCillator:FREQuency[1|2]? [MIN|MAX]

This query returns the programmed frequency at specified port, in Hz or minimum-maximum acceptable range limits.

Response format = <NR3>.

ROSCillator:MVOLTage?

This query returns the Oscillator oven monitor voltage.

Response format = <NR3>, precision = 1×10^{-1} V.

STATus Monitoring Commands

The STATus commands allow you to examine the status of the instrument by monitoring the Operation Status register and the Questionable Data register. Figure 5-1 shows all of the instrument's status registers.

The STATus system contains four registers (and the Output Queue), two of which are under IEEE 488.2 control. These are the Standard Event Status Register (ESR) and the Status Byte Register (SBR). The other two are the Standard Operation Status register and Questionable Data register. Refer to the Common command descriptions in Table 5-1 and the Status Reporting section of this chapter for more details.

The two registers under the instrument's control are the Standard Operation Status register and the Questionable Data register. These registers may be set and queried.

Parameter Entry

Parameter entry for both registers is numeric only. Numeric types may be Decimal, Hexadecimal, Octal, or Binary. The decimal numeric range is between 0 and 32767. The *RST value is 0. Sending a decimal value of 64 will set bit 6.

Bit Number	0	1	2	3	4	5	6	7	8	9	10	11	12	13	14	15
Decimal Value	1	2	4	8	16	32	64	128	256	512	1024	2048	4096	8192	16384	N/A

Using the Operation Status Register

The 16-bit Operation Status register monitors instrument operations currently being performed. The instrument implements bits 0, 8, 9, 10, 11, and 12 to monitor various internal operations. Refer to the Status Reporting section of this chapter for definitions of these bits.

The Operation Status register group consists of a condition (C) register, an event (EV) register, and an enable (EN) register as shown in Figure 5-1. The commands in the STATus:OPERation subsystem control and monitor these registers.

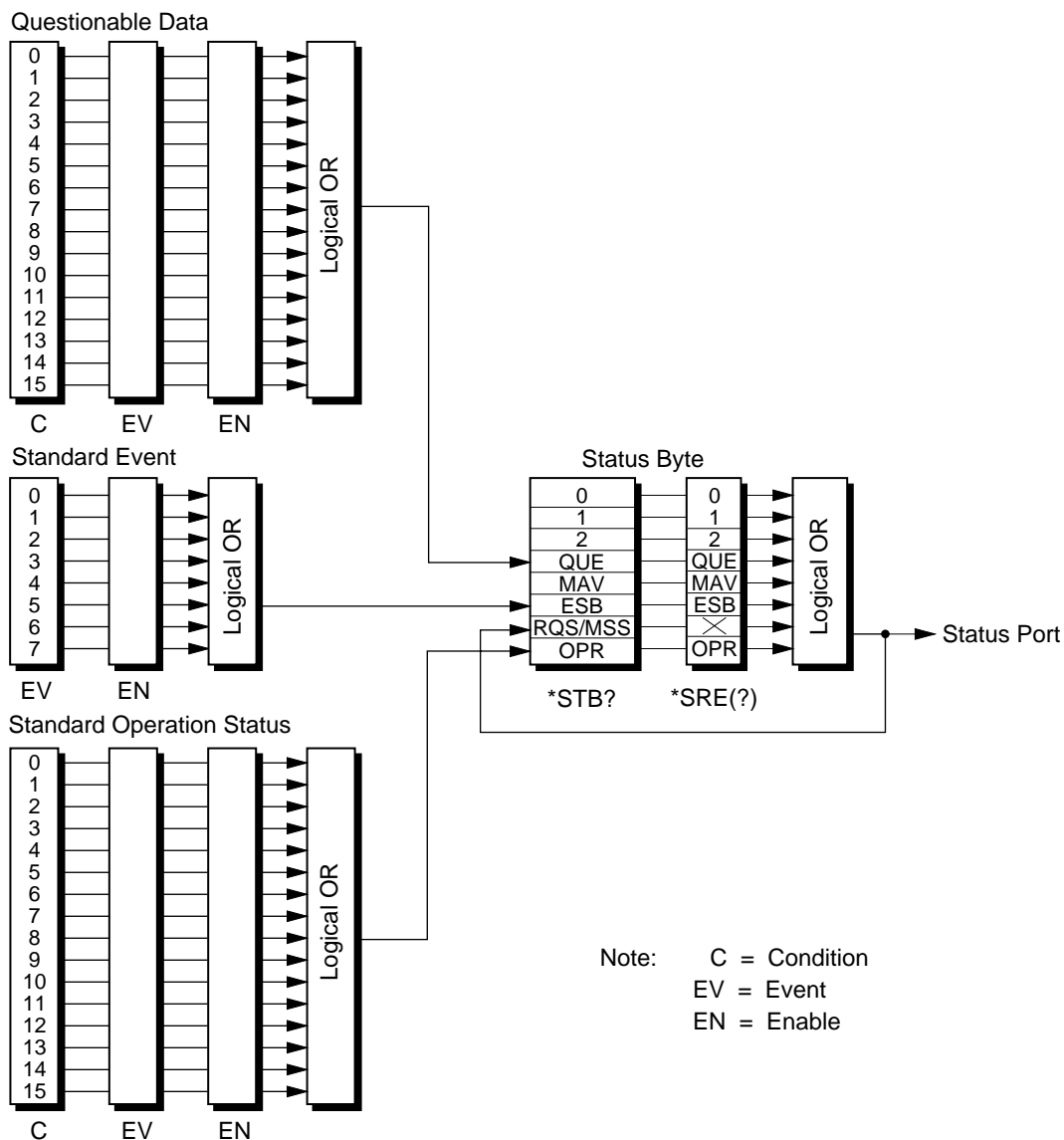

Figure 5-1. Status System Registers

Description of SCPI Commands

STATus:OPERation[:EVENT]?

This query returns the contents of the OPERation event register, then clears the event register.

The event register bits are determined by the settings of the corresponding rise, fall, and condition registers.

Response format = <NR1>.

STATus:OPERation:CONDition?

This query returns the contents of the OPERation condition register, non destructively.

Response format = <NR1>.

STATus:OPERation:ENABLE <numeric_value>

This command sets the OPERation enable register to the specified value.

Meaningful values are in the range 0 to 32767.

STATus:OPERation:ENABLE?

This query reports OPERation enable register contents, non-destructively.

Response format = <NR1>.

STATus:OPERation:NTRansition <numeric_value>

This command sets the negative transition filter (fall register) as specified.

Meaningful values are in the range 0 to 32767.

STATus:OPERation:NTRansition?

This query returns the contents of the fall register.

Response format = <NR1>.

STATus:OPERation:PTRansition <numeric_value>

This command sets the positive transition filter (rise register) as specified.

Meaningful values are in the range 0 to 32767.

STATus:OPERation:PTRansition?

This query reports the contents of the rise register.

Response format = <NR1>.

Using the Questionable Data Register

The Questionable Data Register conveys information about the quality of the instrument's functions and outputs. The 5071A implements bits 2, 5, and 6 of the Questionable Data Register. (Refer to the Status Reporting section of this chapter for more details.)

The Questionable Data Register group consists of a condition register, an event register, and an enable register as shown in Figure 5-1. The commands in the STATus:QUEStionable subsystem control and monitor these registers.

The STATus:QUEStionable subsystem commands query the QUEStionable Register to indicate whether an overflow has occurred for a specific function after an associated command has executed. When any of the bits are set (questionable data), bit 3 of the Status Register is set to 1 if enabled by the STAT:QUES:ENAB command.

STATus:QUEStionable[:EVENT]?

This query reports contents of the QUEStionable event register, then clears the event register.

The event register bits are determined by the settings of the corresponding rise, fall, and condition registers.

Response format = <NR1>.

STATus:QUEStionable:CONDition?

This query reports contents of the QUEStionable condition register, non destructively.

Response format = <NR1>.

STATus:QUEStionable:ENABLE <numeric_value>

This command sets QUEStionable enable register to the specified value.

Meaningful values are in the range 0 to 32767.

Description of SCPI Commands

STATus:QUEStionable:ENABle?

This query reports the contents of the QUEStionable enable register, non destructively.

Response format = <NR1>

STATus:QUEStionable:NTRansition <numeric_value>

This command sets the negative transition filter (fall register) as specified.

Meaningful values are in the range 0 to 32767.

STATus:QUEStionable:NTRansition?

This query reports the contents of the fall register.

Response format = <NR1>.

STATus:QUEStionable:PTRansition <numeric_value>

This command sets the positive transition filter (rise register) as specified.

Meaningful values are in the range 0 to 32767.

STATus:QUEStionable:PTRansition?

This query reports the contents of the rise register.

Response format = <NR1>.

STATus:PRESet

This command clears the OPER and QUES enable registers, sets the rise registers, and clears the fall registers.

System Commands

The SYSTem commands control functions related to remote system communication, configuration, and any error messages.

NOTE

Any commands which alter the state of the instrument will return error +201 if the instrument is not in REMOTE mode when the command is issued.

SYSTem:ERRor?

This query returns error numbers and corresponding error messages in the error queue.

- Refer to the error message listing at the end of this chapter for details of error codes, messages and meanings.
- Response format = <NR1>.
- When an error occurs within the instrument, its corresponding number and message are generated and stored in the error queue.
- One error is removed from the error queue each time the SYSTem:ERRor? command is executed. The errors are cleared in a first-in, first-out order. This means that if several errors are waiting in the queue, each SYSTem:ERRor? query returns the oldest (not the most recent) error. That error is then removed from the queue.
- When the error queue is empty, subsequent SYSTem:ERRor? queries return +0, "No error". To clear all errors from the queue, execute the *CLS command.
- The error queue has a maximum capacity of 30 errors. If the queue overflows, the last error is replaced with -350, "Too many errors". No further errors are accepted until space is available.
- The error queue is empty at power-on.

Description of SCPI Commands**SYSTEM:KEY <numeric_value>**

This command inserts the specified keycode into the keypress queue. Operates with remote OFF.

Input range: 0 to 19, 128 to 149.

Code 148 turns the SHIFT annunciator On, while code 0 turns it Off.

Codes 1 - 19 point to unshifted keys in left-right, top-bottom order.

Add 128 to any keycode to arrive at its shifted code.

Codes 20, 128, and 149 are reserved. (See the key-code listing the following table.)

Key	Code	Shifted Key	Code
Shift OFF	0	INFO	129
Data 7	1	SET CLOCK	130
Data 8	2	SLEW	131
Data 9	3	<-	132
<-	4	->	133
->	5	SERIAL	134
Data 4	6	UTILITIES	135
Data 5	7	LOG	136
Data 6	8	Inc	137
Inc	9	Dec	138
Dec	10	Data 1	139
Data 1	11	Data 2	140
Data 2	12	Data 3	141
Data 3	13	Top	142
Top	14	Prev	143
Prev	15	Data 0	144
Data 0	16	Data .	145
Data .	17	Data +/-	146
Data +/-	18	Enter	147
Enter	19	Shift ON	148
Shift ON	148		

SYSTem:KEY? [MIN|MAX]

This query returns the numeric code of the last keypress or minimum-maximum acceptable range limits.

Does not reflect codes sent by the KEY command.

Response format = <NR1>

SYSTem:PRINt?

This query prints a status report.

This query or command is identical to the front-panel information print command.

Output format = arbitrary ASCII (several lines of ASCII text).

:REMOte

SYSTem:REMOte OFF|0|ON|1

This command enables or disables REMOTE operation mode.

The function of this command is ON at *RST.

SYSTem:REMOte?

This query returns the state of REMOTE mode.

Response format = <0 or 1>

Returns 1 if REMOTE mode is ON, 0 if REMOTE mode is OFF

SYSTem:SCONfiguration

This command saves the following instrument parameters in nonvolatile memory:

- Serial port: baud rate, data bits, stop bits, and parity
- LCD angle
- Output port frequencies
- Printer report level

The 5071A must be in REMote mode to execute this command.

The function of this command is not affected by *RST.

Description of SCPI Commands

SYSTem:TIME <hours>,<minutes>,<seconds>

This command is equivalent to "SOUR:PTIM:TIME".

The function of this command is not affected by *RST.

SYSTem:TIME? [MIN|MAX, MIN|MAX, MIN|MAX]

This query returns 24-hour time or minimum-maximum acceptable range limits.

Response format = <NR1, NR1, NR1>, precision = 1 Second.

SYSTem:VERSion?

This query returns the SCPI version number for which the instrument complies (1990.0).

Response format = <NR2>.

Status Reporting

The 5071A status registers conform to the SCPI and IEEE 488.2 standards applicable with an RS-232C serial data-communications port. RS-232C does not support serial poll, parallel poll, or SRQ. Instead, IEEE SRQ and RQS signals will always have the same state, and will be reflected in the state of the (low TRUE) status output port (rear-panel Status Output BNC connector).

The conditions under which the rear-panel Status Output goes active can be programmed with the commands available in the SCPI STATUS subsystem. These commands are used in conjunction with IEEE 488.2 Common commands. Refer to the next section of this chapter for information about, and examples of, programmed rear-panel Status Output states. The status registers of the 5071A are defined in tables 5-3, 5-4, 5-5, and 5-6 as follows:

Table 5-3. IEEE Summary Status Byte (STB)

Bit	Function	Bit Status
0	unused	—
1	unused	—
2	unused	—
3	QUE	Summary of SCPI QUEStionable status register
4	MAV	IEEE 488.2 MAV bit (unused, always zero)
5	ESB	Summary of IEEE 488.2 Event Status Register
6	MSS	IEEE 488 request status (same state as status port)
7	OPR	Summary of SCPI OPERation status register

Status Reporting**Table 5-4. IEEE Standard Event Status Register (ESR)**

Bit	Function Name
0	OPC IEEE Operation complete
1	RQC (not used)
2	SCPI Query error
3	SCPI Device Dependent Error
4	SCPI Execution Error
5	SCPI Command Error
6	URQ (not used)
7	PON Power On flag

Table 5-5. SCPI OPERation Status Register

Bit	Function	Bit Status
0	CALibrating	Set when performing auto calibration
1	SETTling	always zero
2	RANGing	always zero
3	SWEeping	always zero
4	MEASuring	always zero
5	awaiting TRIG	always zero
6	awaiting ARM	always zero
7	CORRecting	always zero
8	Standby	Set when in standby state
9	On Battery	Set when power source is internal battery
10	Normal	Set when operating normally
11	Fatal	Set when in fatal error state
12	Steered	Set when output frequency is being steered
13	INST summary	always zero
14	PROG running	always zero
15	Unused	always zero

Status Reporting**Table 5-6. SCPI QUEStionable Status Register**

Bit	Function	Bit Status
0	VOLTage	always zero
1	CURRent	always zero
2	TIME	Condition cleared when clock is set.
3	POWER	always zero
4	TEMPerature	always zero
5	FREQuency	Indicates out-of-lock condition (see log)
6	PHASe	Indicates spurious bursts from servo chain
7	MODulation	always zero
8	CALibration	always zero
9	unassigned	always zero
10	unassigned	always zero
11	unassigned	always zero
12	unassigned	always zero
13	INST summary	always zero
14	Command Warning	always zero
15	Unused	always zero

Rear-Panel Status Output Operation

The status port is a rear-panel BNC (Status Output) connected to an open-collector output with pull-up to +5V. This output goes low (active) under circumstances which you can select from a set of programmable conditions listed in the SCPI Operation and Questionable status register descriptions (Tables 5-5 and 5-6 of this chapter).

The status port is connected analogously to an SRQ line in an IEEE-488.2 (HP-IB) system. Specifically, the status port contact closes whenever the SRQ bit (RQS/MSS) of the IEEE 488.2 Status Byte Register is asserted (see Figure 5-1. Status System Registers). Therefore, you use the SCPI and IEEE common commands which control the status model to select which conditions will trigger the status output.

After successful power-on and warm up, the 5071A will assert its status output active when the instrument leaves normal operation. This exit from normal operation may be programmed for a variety of conditions. Two example conditions are described below. The SCPI STATus:PRESet command restores the control registers to SCPI-required values.

Status Output Programming

Programming the rear-panel Status Output consists of eight general steps: (Examples for the Operation Status Register are on the next page.)

1. Choose the conditions you wish to program by referencing tables 5-5 and 5-6 for the available choices.
2. Look up the equivalent decimal value for each associated condition "bit" (See the STATus subsystem section, "Parameter Entry" in this chapter.)
3. Sum all of these decimal values and use this total to enable all the possible conditions. (See example on next page.)
4. Use the STATus:OPERation(or QUEStionable:):ENABLE command to program this value.
5. Sum all decimal values that must assert the Status Output active when they become true. (See example on next page.)
6. Use the STATus:OPERation(or QUEStionable:):PTRansition command to program this true value.

Rear-Panel Status Output Operation

7. Sum all decimal values that must assert the Status Output active when they become false. (See example below.)
8. Use the STATus:OPERation(or QUEStionable:):NTRansition command to program this false value.

Example 1 — Programming the Status Output for a Single True Condition

This example describes how to program the Status Output to go active when the 5071A is operating on its Internal-Standby Battery.

According to Table 5-5, “On Battery” is bit “9”. Bit 9 corresponds to decimal value 512. The resulting SCPI command entries are:

- STAT:OPER:ENAB 512
- STAT:OPER:PTR 512
- STAT:OPER:NTR 0

Be aware that even though no false conditions are programmed, the Negative transition command must however be programmed for zero. You may, at any time set the rise and clear the fall registers of the OPERation and QUEStionable subsystems by issuing the STATus:PRESet command.

Example 2 — Programming the Status Output for Multiple True and False Conditions

This example describes how to program the Status Output to go active when the 5071A encounters any combination of the following transitional conditions:

- | | |
|----------------------------|------------|
| • CALibrating - true | bit = 1 |
| • Standby mode - true | bit = 256 |
| • On Battery - true | bit = 512 |
| • Normal operation - false | bit = 1024 |
| • Fatal error state - true | bit = 2048 |
| • Steered output - true | bit = 4096 |
1. By adding all the condition bit values we get the sum 7937 which is used to program the STAT:OPER:ENAB command.
 2. By adding all the true condition bit values we get the sum 6913 which is used to program the STAT:OPER:PTR command.

Serial-Port Command/Printer Interface

3. By adding all the false condition bit values (in this case, only one) we get the value 1024 which is used to program the STAT:OPER:NTR command.

The resulting SCPI command entries are:

- STAT:OPER:ENAB 7937
- STAT:OPER:PTR 6913
- STAT:OPER:NTR 1024

You may, at any time set the rise and clear the fall registers of the OPERATION and QUESTIONABLE subsystems by issuing the STATus:PRESet command.

NOTE

Although these examples used the OPERATION register functions, you can also use the QUESTIONABLE register functions that are available for questionable conditions as well.

Serial-Port Command/Printer Interface

The following paragraphs describe the operation of the serial-port command and printer interface.

Mode Selection

The serial port may be connected either to a printer or to a device which issues SCPI commands via RS-232C. The primary distinction is whether the instrument generates text in response to internal events.

For example, the serial port may be configured so that the instrument sends text only in response to SCPI commands. You may also configure it so that the serial port announces all changes in the state of the instrument. This sort of configuration is available on the front panel in the config/log screen. Set DISABLED if you want the serial port to be mute unless requested to respond. Set VERBOSE for detailed status and event reporting.

Pacing

The serial port supports both XON/XOFF (software) and DTR/DSR pacing.

Serial-Port Command/Printer Interface

Both pacing features are always enabled. The DSR input of the serial port is pulled up by a resistor so that it is transparent if not connected. Many RS-232C printers support this pacing arrangement. Some also support XON/XOFF. XON/XOFF is also useful when using a terminal. XOFF is the same as control-S, while XON is control-Q.

The Prompt

The SCPI program parser prints a prompt whenever ready for another command. If no errors are in the queue, the prompt appears as: `scpi>`.

NOTE

The prompt string ends with a space (ASCII 32).

If there are errors in the queue, the prompt reflects the number of the most recent unread error in the queue. For example, `E-100>`.

You can read errors from the queue using the `syst:err?` query. This prints the error number and a short description of the error, popping that message from the queue. When the queue is clear, the prompt returns to its normal form. Note: you can clear the queue without reading the messages using the IEEE common `*CLS` command.

End-Of-Line Characters

The 5071A will receive lines terminated with CR (ASCII 13 decimal), LF (ASCII 10 decimal), or one followed immediately by the other, in either order.

There is no support for IEEE 488 `<EOI>`. The instrument always terminates formatted output lines with `<CR>` and `<LF>`. (See also Prompt above.)

Error Messages/Codes

Table 5-7 lists and describes the error messages.

Table 5-7. Error Messages

Number	Error String	Cause
-100	Command error	This is the generic syntax error used if the 5071A cannot detect more specific errors.
-101	Invalid character	Unrecognized character in specified parameter.
-102	Syntax error	Command missing space/comma between parameters.
-103	Invalid separator	Command parameter separated by space is a not comma.
-104	Data type error	Wrong data type specified in parameter.
-108	Parameter not allowed	Parameter specified in parameterless command.
-109	Missing parameter	Parameter missing in entered command.
-112	Program mnemonic too long	Header contains more than 12 characters.
-113	Undefined header	Command header incorrectly specified.
-121	Invalid character in number	Entered character for numeric data is incorrect.
-123	Exponent too large	Exponent larger than 32000.
-124	Too many digits	More than 256 digits specified.
-128	Numeric data not allowed	Number specified for parameter not letter.
-131	Invalid suffix	Parameter suffix incorrectly specified.
-134	Suffix too long	The suffix contained more than 12 characters.
-138	Suffix not allowed	Parameter suffix specified when not allowed.
-141	Invalid character data	Parameter type specified not allowed.
-144	Character data tool long	Character data element has more than 12 characters.
-148	Character data not allowed	Entered character data not recognized by instrument.
-150	String data error	Entered string data contained a non-specific error.
-151	Invalid string data	Entered string data syntax invalid.
-158	String data not allowed	String data encountered but not allowed.
-160	Block data error	Entered block data contained a non-specific error.

Error Messages/Codes**Table 5-7. Error Messages (Continued)**

Number	Error String	Cause
-161	Invalid block data	Entered block data syntax invalid.
-168	Block data not allowed	Block data encountered but was not allowed.
-170	Expression error	Entered expression contained a non-specific error.
-171	Invalid expression	Entered block data syntax invalid.
-178	Expression data not allowed	Expression data encountered but was not allowed.
-180	Macro error	Entered macro command or parameter contained a non-specific error.
-200	Execution error	Requested function is not available.
-221	Settings conflict	Requested configuration conflicts with current setting(s): occurs upon attempt to set leap state ON when duration is 60 or date has expired.
-222	Data out of range	Specified parameter value too large/small.
-223	Too much data	Excess data for memory/device-specific process requirements.
-224	Illegal parameter value	Specified numeric value not allowed.
-230	Data corrupt or stale	New function started but not completed since last access.
-231	Data questionable	Output data accuracy is suspect.
-300	Device-specific error	This is the generic device-dependent error.
-310	System error	Non-specific system error has occurred.
-350	Queue overflow	The error queue is full - more than 8 errors have occurred.
+201	SYSTem:REMOte must be ON	Requested entry not allowed when REMote is OFF.
+202	Valid only when operating normally	Requested entry not allowed in current operating state.
+203	Valid only in Standby	Requested entry not allowed in Normal operating mode.

6

Specifications

Introduction

This chapter provides the technical specifications for the 5071A. Specifications describe the instrument's warranted performance. Supplemental characteristics are intended to provide information useful to apply the instrument by giving typical or nominal, but nonwarranted performance parameters.

Chapter Summary

- Accuracy and Stability 6-3
- Frequency Stability (5- and 10-MHz outputs) 6-4
- Sinusoidal Output Characteristics 6-4
- Supplemental Characteristics 6-5
- Telecommunications Options 6-7

Accuracy and Stability

Conditions:

Any combination of:

Temperature: 0 to 50°C

Humidity: 0 to 80% (40°C maximum)

Magnetic Field: dc, 55, 60 Hz; 0 to 0.2 millitesla (2 Gauss) peak —
any orientation

Pressure: 47 kPa (equivalent to an altitude of 6 km)

Shock Vibration: 100-mm drop

Parameter		Standard Cesium Beam Tube. Values are within:	High-performance Cesium Beam Tube (Option 001).
Accuracy†		$\pm 1 \times 10^{-12}$	$\pm 5 \times 10^{-13}$
Frequency Change vs Environment		$\pm 1 \times 10^{-13}$	$\pm 8 \times 10^{-14}$
Warm-up Time: To normal operation status (typical) To full specifications (typical)		15 minutes 30 minutes	15 minutes 30 minutes
Reproducibility†		$\pm 1.0 \times 10^{-13}$	$\pm 1.0 \times 10^{-13}$
Long-term Stability			
Time domain Stability†	Averaging Time		
5- and 10-MHz outputs	10 ⁴ seconds	$\leq 2.7 \times 10^{-13}$	$\leq 8.5 \times 10^{-14}$
	10 ⁵ seconds	$\leq 8.5 \times 10^{-14}$	$\leq 2.7 \times 10^{-14}$
	5 days	$\leq 5.0 \times 10^{-14}$	$\leq 1.0 \times 10^{-14}$
	30 days	$\leq 5.0 \times 10^{-14}$	$\leq 1.0 \times 10^{-14}$
Flicker Floor Value†	Guaranteed	$\leq 5.0 \times 10^{-14}$	$\leq 1.0 \times 10^{-14}$
	Typical††	$\leq 1.5 \times 10^{-14}$	$\leq 5.0 \times 10^{-15}$

† Footnotes are defined starting on page 6-7.

Frequency stability (5- and 10-MHz outputs)

Time Domain Stability †

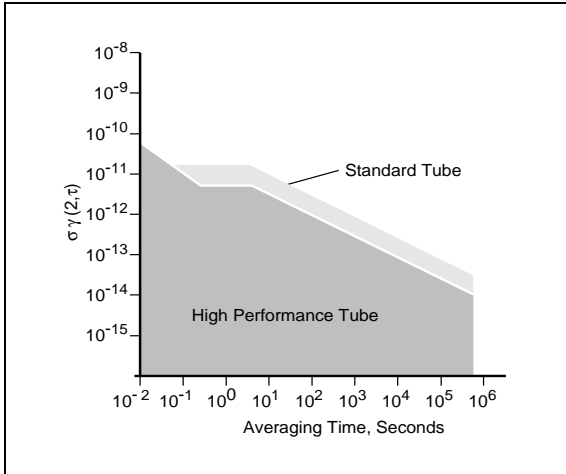

Averaging Time (Seconds)	$\sigma_y(2, \tau)^\dagger$	
	Standard Cesium Beam Tube	High-Performance Cesium Beam Tube (Option 001)
10^{-2}	$\leq 7.5 \times 10^{-11}$	$\leq 7.5 \times 10^{-11}$
10^{-1}	$\leq 1.2 \times 10^{-11}$	$\leq 1.2 \times 10^{-11}$
10^0	$\leq 1.2 \times 10^{-11}$	$\leq 5.0 \times 10^{-12}$
10^1	$\leq 8.5 \times 10^{-12}$	$\leq 3.5 \times 10^{-12}$
10^2	$\leq 2.7 \times 10^{-12}$	$\leq 8.5 \times 10^{-13}$
10^3	$\leq 8.5 \times 10^{-13}$	$\leq 2.7 \times 10^{-13}$
10^4	$\leq 2.7 \times 10^{-13}$	$\leq 8.5 \times 10^{-14}$
10^5	$\leq 8.5 \times 10^{-14}$	$\leq 2.7 \times 10^{-14}$
5 days	$\leq 5.0 \times 10^{-14}$	$\leq 1.0 \times 10^{-14}$

Frequency Domain Stability †

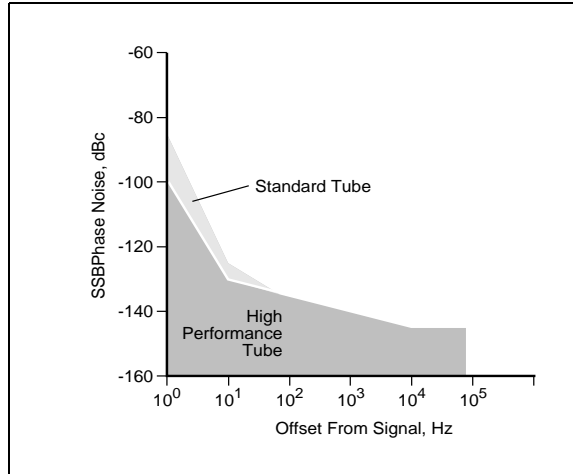

Offset from Signal (Hz)	SSB Phase Noise [†] dBc	
	Standard Cesium Beam Tube	High-Performance Cesium Beam Tube (Option 001)
100	≤ -85	≤ -100
101	≤ -125	≤ -130
102	≤ -135	≤ -135
103	≤ -140	≤ -140
104	≤ -145	≤ -145
105	≤ -145	≤ -145

Sinusoidal output characteristics (all located on rear panel)

Parameter	Ports 1 & 2 ⁽¹⁾	1 MHz, 100 kHz
Amplitude into 50Ω load	> 1 Vrms	> 1 Vrms
Isolation† between ports	> 110 dB (typ)	not specified
Harmonic signals (typical)	< -40 dBc	< -40 dBc
Non-harmonic distortion	< -80 dBc	not specified
Connector type	N	BNC
Source impedance (nominal)	50Ω	50Ω

⁽¹⁾ Each output can be set to either 5 or 10 MHz from the front panel or by remote command.

† Footnotes are defined starting on page 6-7.

Supplemental Characteristics †**Time Standard****Clock Display**

24-hour red LED display of hours, minutes, and seconds.

Clock 1 PPS Outputs

All outputs are isolated from each other.

Amplitude: ≥ 2.4 V into 50Ω (output levels are TTL compatible).

Width: $20\ \mu\text{s} \pm 10$ ns

Rise Time: < 5 ns (slew rate $> 10^9$ volts/second at 1.5 volts).

Jitter: < 1 ns rms (pulse-to-pulse or pulse-to-10-MHz).

Connectors: BNC.

Locations: one on front panel, two on rear panel

Clock Synchronization

Automatic synchronization: to within 50 ns of reference pulse.

Sync pulse: 2 inputs; each may be independently armed.

Amplitude: +2 to +10 volts (maximum). Pulse width must be less than $100\ \mu\text{s}$ maximum.

Width: 100 ns minimum, $100\ \mu\text{s}$ maximum.

Rise Time: < 50 ns.

Input impedance: $50\ \Omega$ (nominal).

Time reference: rising edge

Connectors: BNC.

Location: one on front panel, one on rear panel.

Manual synchronization:

Range: -0.5 to + 0.5 s.

Resolution: 50 ns.

Frequency settability†

Resolution: 6.3×10^{-15}

Range: $\pm 1.0 \times 10^{-9}$

Internal Standby Battery (Nominal Values)**Capacity**

45 minutes at 25°C from full charge.

Charge Time

16 hours maximum from fully discharged state.

Charge source

ac input power only.

Remote System Interface and Control**RS-232C (DTE configuration)**

Provides complete remote control and interrogation of all instrument functions and parameters. RS-232C interface circuits are optically isolated and floating with respect to 5071A chassis.

Software command set:

Standard commands for Programmable Instruments (SCPI), version 1990.0 adapted for RS-232C.

Connector: 9-pin male rectangular D subminiature type.

Status Output

Provides a logic output to monitor normal and abnormal operation externally. Parameters which define abnormal operation can be user programmed.

Output: TTL High, Normal

TTL Low, Fault

Circuit is TTL open collector with internal pull-up resistor.

Circuit can sink up to 10 mA.

Connector: BNC located on rear panel.

Power Requirements

Input voltage:

ac: 100, 120 Vac $\pm 10\%$, 45 to 440 Hz.

220, 240 Vac $\pm 10\%$, 45 to 66 Hz.

dc: 22 to 42 Vdc operating (for 48 Vdc operation, see Opt 48).

Damage level: 55 V.

NOTE: Both dc input terminals are floating. Either input terminal may be connected to the chassis, or both may be left floating. The maximum allowable voltage between either input terminal and the chassis is 45 V.

Input power (nominal):

ac: Primary power source; unit will draw ac power in preference to dc power.

Warm-up:

Standard: 100W, 140 VA.

Option 001: Same as standard unit.

Operating:

Standard: 50W, 70 VA.

Option 001: 56W, 78 VA.

dc:

Warm-up:

Standard: 85W.

Option 001: 85W

Operating:

Standard: 45W

Option 001: 50 W.

Standby operation:

Unit requires 20% less power.

† Footnotes are defined starting on page 6-7.

Supplemental Characteristics † (continued)
Environmental**Temperature:**

Operating: 0 to 55°C.

Non-operating: -40 to 70°C.

Humidity:

0 to 95% relative humidity (at maximum temperature of 45° C).

Atmospheric pressure:

<math>1 \times 10^{-13}</math> change in frequency for pressure change down to 19 kPa (equivalent to an altitude of about 12.2 km).

Shock and vibration:MIL-T-28800D, Type III,
Class 5.**Hammer Blow Shock Test,**MIL-S-901C, Grade A, Class 1,
Type A.

EMI: C1SPR 22, Class A.

CISPR 11, Group 1, Class A;

MIL-STD-461 C, Part 7, Class B.

dc magnetic field: up to
7.8 Gauss.**Weight:**

Net weight: 30 kg

Shipping weight: 40 kg

Dimensions**Height**

133.4 mm

Width

425.5 mm

Depth

523.9 mm

This includes spacers which extend
25.4 mm beyond the rear panel.**Warranty****Electronics**

1 year.

Cesium beam tube

Standard tube: 10 years.

High-performance tube
(Option 001): 3 years.**Accessories Furnished****Power Cord**

180 cm detachable.

dc input Connector:Part number 1251-0126
(5 contact), Cannon MS3106E-14S-5S
(series ME).

Cabinet front handles kit.

Accessories AvailableRack Slides: (see Options for other
rack mounting hardware)Fixed Slides: order part number
1494-0059.**Application note available**Application Note 1289, *The Science of
Timekeeping*.**5071A Options****001:** High Performance Cesium Beam
Tube.**5071A Options (continued)****OB2:** One Extra Set of Operating
and Programming
Documentation**OBW:** Assembly-level Service
Manual (Contact your local
Agilent Sales Office for pricing
and availability.)**908:** Rack Flange Kit. Use for
mounting the 5071A when
front handles will not be used.
Also available under part
number 5062-3977.WARNING: Do not mount this
product by the rack flanges
alone. Always use a shelf,
rails, or slides.**913:** Rack Flange Kit. Use with
front handles supplied with
5071A. Also available under
part number 5062-3983.
WARNING: Do not mount this
product by the rack flanges
alone. Always use a shelf,
rails, or slides.**W30:** Two additional years of
“Return to Agilent” service on
the electronics (the cesium
beam tube is warranted
separately). This option adds
to the basic electronics
warranty to provide a total of
three years of coverage.**W50:** Four additional years of
“Return to Agilent” service on
the electronics (the cesium
beam tube is warranted
separately). This option adds
to the basic electronics
warranty to provide a total of
five years of coverage.

† Footnotes are defined starting on page 6-7.

Telecommunications Options

048: This option equips the frequency standard to operate from 48-Vdc nominal power. The range that the frequency standard will accept is 40-58 Vdc. Maximum dc power consumption is 100W. Two independent 48-Vdc power sources may be supplied. The power sources must be of the same polarity but either polarity may be used. The instrument automatically uses 48-Vdc source if one is present. If no dc source is available, the instrument will attempt to use ac power. The internal battery normally supplied with the 5071A is not available when Option 048 is installed.

The telecom signal options all contain the following outputs:

- 8kHz frame sync in (TTL level into 50 Ω)
- 8kHz frame sync out (TTL level into 50 Ω)
- Sync out (Telecommunications rate 1.544 or 2.048 Mbps) (TTL level into 50 Ω)
- Sync out (1.544 or 2.048 MHz), per G.703-10.

In addition, each option has a framed output whose characteristics are determined by the following option numbers. The telecommunications signal outputs comply with ITU recommendations G.703 and G.704 for electrical signal characteristics and formatted content.

- 104:** 1.544 Mbps, 100 Ω balanced, super frame (D4)
- 105:** 1.544 Mbps, 100 Ω balanced, extended super frame (ESF)
- 220:** 2.048 Mbps, 120 Ω balanced, common channel signaling
- 221:** 2.048 Mbps, 120 Ω balanced, channel associated signaling
- 222:** 2.048 Mbps, 120 Ω balanced, channel associated signaling with CRC4
- 270:** 2.048 Mbps, 75 Ω unbalanced, common channel signaling
- 271:** 2.048 Mbps, 75 Ω unbalanced, channel associated signaling
- 272:** 2.048 Mbps, 75 Ω unbalanced, channel associated signaling with CRC4

Footnotes:

Accuracy: The degree to which the 5071A output frequency differs from that of the accepted definition. The currently-accepted definition is that of the 13th General Conference of Weights and Measures and is based on Cesium (The hyperfine resonance of the Cesium 133 atom in zero magnetic field is 9.192631770 GHz.). In practice, this involves comparison with some generally-accepted physical embodiment of this definition such as one of the time standards in the international time scale (TIA) monitored by the BIH (Bureau International L'Heure) in Paris, France. The specified accuracy of the 5071A is intrinsic and is maintained without calibration.

Flicker Floor: The level at which the Allan variance time domain stability measurement remains constant with increased averaging time. The Allan Variance statistical method for measuring time domain stability responds in several ways to various noise processes in a cesium standard. Many of these noise processes produce contributions which average out or decrease as the averaging time increases. Flicker noise, on the other hand, gives rise to an Allan variance independent of averaging time. Thus, the Allan variance of a typical frequency standard will decrease with increasing time, until a relatively constant value is reached. This value is known as the *flicker floor*.

Flicker Floor Value, Typical: Typical flicker floor performance measure is based on long-term measurements made by NIST.

Frequency Domain Stability: (also called single-sideband phase noise or additive noise). Describes the spectral noise in the specified output signal caused by phase modulation from internal noise sources. The measurement is normalized by expressing the ratio of noise power (in a 1-Hz bandwidth) to the signal power, then measured as a function of offset from that signal. For more information see NIST Technical Note 1337, Characterization of Clocks and Oscillators available from the Superintendent of documents, U.S. Government Printing Office, Washington DC 20402-9325.

Specifications

Footnotes:

Frequency Settability: The degree to which the frequency of the 5071A may be adjusted to correspond with a reference without loss of stability.

Isolation: The degree to which one output of the 5071A is affected by changes in loading on another output of the same standard. In practice, this represents a change in amplitude, frequency, or phase as seen at one terminal due to the effect of placing a short, open, or reactance on another terminal. In the 5071A, both the Port 1 and Port 2 high isolation output frequencies are derived from the same source; there is no measurable change in frequency. The change in amplitude or phase is measured as the level of the sideband at one port, which results from applying and removing the load at a low frequency rate at the other port. The measurement is the level of the resulting sideband compared to the nominal output level, expressed in decibels.

Reproducibility: The degree to which the 5071A will reproduce the same frequency from one occasion to another after an interruption in operation. This does not include any calibration procedure but may require degaussing.

Supplemental Characteristics: Specifications refer to the instruments' warranted performance. Supplemental characteristics are typical or nominal values intended to provide information useful in applying the instrument.

Time Domain Stability: (also called short-term stability); The standard deviation of fractional frequency fluctuations in the specified output signal due to random noise in the cesium standard. The mathematical method by which it is calculated is called the Root Allan Variance. Symbolically, it is represented by the term $\sigma_y^{(2, \tau)}$ where σ_y is the standard deviation, 2 means that measurements are taken in pairs, and τ is the measurement time.

In the 5071A specifications, values for all averaging times are shown in one chart for convenience. However, short-term stability specifications for averaging times in excess of 1000 seconds are valid only under laboratory conditions (temperature 25 ± 5 °C, relative humidity $45\% \pm 10\%$). For more information on time domain stability, see NIST Technical Note 1337, Characterization of Clocks and Oscillators available from the Superintendent of documents, U.S. Government Printing Office, Washington D.C. 20402-9325.

Chapter Contents

This chapter provides information to inspect, install, commission, and maintain the 5071A Primary Frequency Standard. Installation information is also provided for external-dc operation and rack-mounting.

The chapter is organized as follows:

- Initial Inspection page 7-3
- Preparation for Use page 7-4
 - Power Requirements page 7-4
 - Selecting Line Voltage and Fuse page 7-5
 - AC Power Cabling page 7-6
 - Operating Environment page 7-7
 - Bench Operation page 7-7
 - Installing Options 908 and 913 page 7-7
- Returning the 5071A to Agilent page 7-8
- Operator's Maintenance page 7-11
- Operating the 5071A From External-DC Power page 7-11
 - Preparing the 5071A For External-DC Operation page 7-11
 - Replacing the External DC Input Power Fuse page 7-12
- Internal Standby Battery Maintenance page 7-13
 - Battery Shelf Life and Storage page 7-13
 - Battery Operating Temperatures page 7-13
 - Battery Charging page 7-14
 - Battery Disposal page 7-15
 - Using the Battery Disconnect Switch page 7-15
 - Removing and Replacing the Internal Battery page 7-16
- Cesium Beam Tube Replacement page 7-17
- Long-Term Storage page 7-17

Initial Inspection

Inspect the shipping container and cushioning material for signs of damage.

- If damage is evident, keep the packing materials until the contents of the shipment have been checked for completeness and the instrument has been checked mechanically and electrically.
- If the contents are incomplete, if there is mechanical damage or defect, or if the instrument or some component fails operational verification or full performance test, notify the nearest Agilent office.
- If the shipping container is damaged, or the cushioning material shows signs of stress, notify the carrier as well as the Agilent office.

Keep the shipping materials for the carrier's inspection. The Agilent office will arrange for repair or replacement at Agilent's option without waiting for a claim settlement.

WARNING

TO AVOID HAZARDOUS ELECTRIC SHOCK, DO NOT PERFORM ELECTRICAL TESTS WHEN THERE ARE SIGNS OF SHIPPING DAMAGE TO ANY PORTION OF THE OUTER ENCLOSURE (COVERS, PANELS, CONNECTORS, LEDS, ETC.).

Preparation for Use

This section describes:

- Power requirements, line voltage and fuse selection, and available ac-power cables
- Operating environment
- Bench Operation
- Installing options 908 or 913
- How to return the instrument to Agilent.

Power Requirements

The 5071A can operate from ac power sources of 100-, 120-, 220-, or 240 volts ac, 45 to 66 Hertz for all voltages, 400 (10%) Hertz for 100-, and 120-volts ac. Maximum ac-power consumption is 100W, 140VA.

Operating power may also be supplied as external dc voltages between 22 and 42 Vdc. Maximum dc-power consumption is 85 W. Refer to Chapter 6, “Specifications,” for more details, and the section in this chapter that explains auxiliary dc-power operation.

WARNING

THIS IS A SAFETY CLASS I PRODUCT PROVIDED WITH A PROTECTIVE EARTH TERMINAL. AN UNINTERRUPTIBLE SAFETY EARTH GROUND MUST BE PROVIDED FROM THE MAINS POWER SOURCE TO THE PRODUCT INPUT WIRING TERMINALS, POWER CORD, OR SUPPLIED POWER-CORD SET. WHENEVER IT IS LIKELY THAT THE PROTECTION HAS BEEN IMPAIRED, THE INSTRUMENT MUST BE MADE INOPERATIVE AND BE SECURED AGAINST ANY UNINTENDED OPERATION.

IF THIS INSTRUMENT IS TO BE ENERGIZED VIA AN EXTERNAL AUTOTRANSFORMER FOR VOLTAGE REDUCTION, MAKE SURE THAT THE COMMON TERMINAL IS CONNECTED TO THE EARTHED POLE OF THE POWER SOURCE. FAILURE TO GROUND THE INSTRUMENT CAN RESULT IN PERSONAL INJURY. REFER TO THE PARAGRAPH TITLED “AC POWER CABLING”.

Preparation for Use

Selecting Line Voltage and Fuse

CAUTION

Before Plugging This Instrument into the Mains (line) voltage, be sure the correct line voltage and fuse have been selected. You must set the voltage selector turret wheel correctly to adapt the 5071A to the power source as described in the following paragraphs.

The 5071A is equipped with an ac-power module (on the rear panel) that contains a turret wheel selector to select 100-, 120-, 220-, or 240 volt ac-operation as shown in Figure 7-1. Before applying ac power to the 5071A, the turret wheel selector must be set to the correct position and the correct fuse must be installed as described in the following paragraphs.

Appropriate power-line connections are selected by the position of the plug-in turret wheel in the module. The correct-value fuse, with a 250-volt rating must be installed before the turret wheel is inserted. This instrument uses a 1.5A slow-blow fuse (part number 2110-0304) for 100/120-volt operation and a 0.75A slow-blow fuse (part number 2110-0360) for 200/240-volt operation.

To change the line voltage, first disconnect the ac-power cord from the module and then follow the instructions in Figure 7-1.

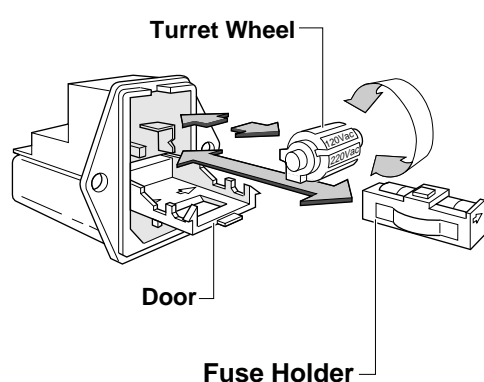

SELECTION OF OPERATING VOLTAGE

1. Using a small, flat-head screwdriver, snap open the power module door to access the fuse and turret wheel.
2. REMOVE the turret wheel before turning to desired voltage. DO NOT turn turret wheel while installed in module. Push wheel firmly into module slot.
3. To change or install fuse, pull fuse holder and re-insert fuse in holder, using caution to select correct fuse value. Re-insert fuse and holder.
4. Close the power module door. The selected operating voltage is shown in module window.

Figure 7-1. Line Voltage and Fuse Selection with Power Module Turret Wheel

Preparation for Use

AC Power Cabling

This instrument is equipped with a three-wire power cable. When connected to an appropriate ac-power receptacle, this cable grounds the instrument cabinet. The type of power cable shipped with each instrument depends on the country of destination. Table 7-1 lists the part number of the power cables and the available mains plugs.

Table 7-1. AC Power Cables Available

Plug Type	Cable Part No.	*C D	Plug Description	Cable Length (Inches)	Cable Color	For Use In Country
250V	8120-1351	0 6	Straight **BS1363A 90°	90 90	Mint Gray Mint Gray	United Kingdom, Cyprus, Nigeria, Zimbabwe, Singapore
250V	8120-1369 8120-0696	0 4	Straight NZSS198/ASC112 90°	70 87	Gray Gray	Australia, New Zealand
250V	8120-1689 8120-1692	7 2	Straight **CEE7-Y11 90°	79 79	Mint Gray Mint Gray	East and West Europe, Egypt, (Unpolarized in many nations)
125V	8120-1348 8120-1389 8120-1754 8120-1378 8120-1521 8120-1676 8120-4753	5 5 7 1 6 1 3	Straight **NEMA5-15P 90° Straight **NEMA5-15P Straight **NEMA5-15P 90° Straight **NEMA5-15P Straight **NEMA5-15P	80 80 36 80 80 30 90	Black Black Black Jade Gray Jade Gray Jade Gray Dark Gray	United States, Canada, 100V or 200V, Mexico, Philippines, Taiwan, Saudi Arabia, Japan
250V	8120-2104	3	Straight **SEV1011 1959-24507	79	Gray	Switzerland
250V	8120-0698	6	Straight **NEMA6-15P	—	—	United States, Canada
220V	8120-2956 8120-2957	2 3	Straight **DHCK 107 90°	79 79	Gray Gray	Denmark
220V	8120-4211 8120-4600	7 8	Straight 90°	—	Gray Gray	South Africa, India
<p>*CD = Check Digit (refer to Replaceable Parts in Service Manual).</p> <p>**Part number shown for plug is industry identifier for plug only. Number shown for cable is Part Number for complete cable including plug.</p> <p>E = Earth Ground L = Line N = Neutral</p>						

Operating Environment

The 5071A may be operated in temperatures from 0 to 55° C. Refer to the environmental specifications in chapter 6 for more detailed information.

Bench Operation

The instrument has plastic feet for convenience in bench operation. The plastic feet are keyed to facilitate self-alignment when stacking instruments.

WARNING

THE 5071A WEIGHS 30 KG (66 LBS). CARE MUST BE TAKEN WHEN LIFTING THE INSTRUMENT TO AVOID PERSONNEL INJURY. ALWAYS USE SLIDING RAILS OR RACK TRAY WHEN RACK MOUNTING.

Installing Options 908 and 913

Options 908 and 913 facilitate rack-mount installation for the 5071A. The options differ as follows:

- The option 908 rack-mount kit provides the hardware necessary to mount the 5071A in a standard rack with flanges and no handles.
- The option 913 rack-mount kit provides the hardware necessary to mount the 5071A in a standard rack with flanges and handles.

WARNING

WHEN INSTALLING THE 5071A IN AN INSTRUMENT RACK WITH EITHER OPTION 908 OR 913, YOU MUST USE EITHER AN INSTRUMENT SUPPORT TRAY OR SLIDE-MOUNT RAILS ON THE INSIDE OF THE INSTRUMENT RACK. FAILURE TO DO SO WILL RESULT IN RACK-MOUNT FLANGE FAILURE AND SUBSEQUENT INSTRUMENT DAMAGE.

The rack-mounting contents and detailed instructions are provided with each rack-mount kit. (Be sure to remove the plastic feet from the instrument before installing in a rack.) If a kit was not ordered with the instrument, it can be ordered through your nearest Agilent Sales and Support office by using the following part numbers: part number 5062-3977 for option 908, and part number 5062-4071 for option 913.

A Rack Slide-Mount Kit is also available. The rack-slide lessens the need to lift the 5071A and is required to support the instrument's weight when installed in a rack if an internal support tray is not present. The available Rack Slide-Mount Kit part number is 1494-0059.

Returning the 5071A to Agilent

The following paragraphs provide information to properly package and ship the 5071A.

When packing has been completed:

- mark the shipping container as FRAGILE to ensure careful handling, and
- in any correspondence, refer to the contents by both the product model (or part) number and the product's full serial number.

If the *original* packing materials are *not* available, obtain a 59991-91105 Packing kit which consists of the items listed in Table 7-2.

Table 7-2. Contents of 59991-91105 Packing Kit

Part Number	Quantity	Description	Callout
9220-4915	2	Tube, Corrugated	1
9211-6672	1	Tray	2
9220-4972	2	Insert	3 and 7
5040-6967	16	Pad, foam-corner	4 and 8
5040-6968	1	Plastic Cap	5
9220-4914	1	Insert	6
9211-6671	1	Carton, corrugated cardboard inner	9
05071-80027	1	Corrugated Outer Box	not shown
None	As Req'd	Reinforced packing tape	N/A
None	As Req'd	Staples	N/A

Returning the 5071A to Agilent

Perform the following steps to package the 5071A for shipment:

- 1** Pack the instrument as shown in Figure 7-2, on the next page, using the instructions provided with the packing kit. (You do not need to return the manual and power cord.):
- 2** After you've finished packing the instrument in the inner corrugated carton, place it into the outer corrugated carton using 8 of the foam pads and then securely staple and/or tape closed.
- 3** Ensure that all labels are attached and instructions provided with the packing kit have been completed.

Chapter 7 Installation
Returning the 5071A to Agilent

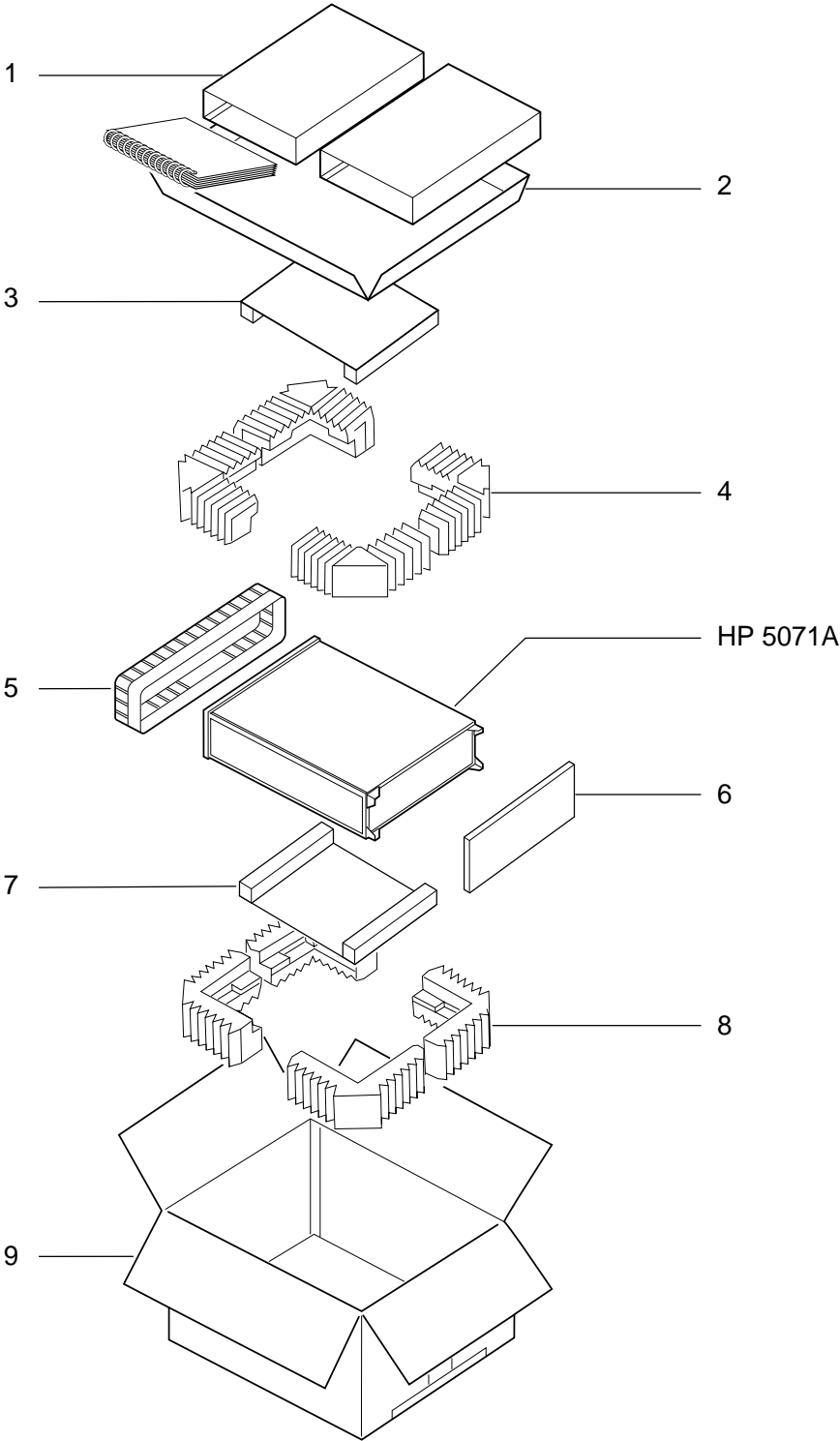

Figure 7-2. 5071A Packing Exploded View

Operator's Maintenance

The 5071A requires NO operator maintenance or calibration during normal operation.

Operating the 5071A From External-DC Power

In addition to ac-power capability, the 5071A can also be operated from an external dc source with a voltage range of ± 22 to 42 Vdc; 85 W. The dc-power source may be applied simultaneously, with the ac-power source. DC-power requirements are listed in Chapter 6, "Specifications," on page 6-5. DC-power connections are made through the rear panel "Ext DC Input" connector.

NOTE

The 5071A runs from ac power when both ac and dc power are available. The 5071A will not run from dc power unless the ac power source fails or is disconnected.

Preparing the 5071A For External-DC Operation

Use the dc-power connector (supplied), that mates with the Ext DC Input connector on the rear panel, to connect dc power to the 5071A. Follow the procedure below to set up and verify operation from auxiliary dc power:

- 1 Connect the positive (+) terminal of the 22 to 42 Vdc power to pin A of the 5-pin Series ME, Cannon connector.
- 2 Connect the negative terminal of the external dc power to pin C. (Either line of the external-dc source may be grounded.)
- 3 Connect the chassis ground to pin E. (The two remaining pins are not used.)
- 4 Check your connections for correct polarity and voltage range.
- 5 Connect external-dc power to the rear-panel Ext DC Input connector.
- 6 Remove ac power from the rear-panel ac-power input connector. Observe the front panel, the ATTENTION light remains extinguished and the front-panel status message will read: "Source: DC". Refer to Table 2-2 for more status details.

- 7 Re-apply ac power, the front-panel status message reads: "Source: AC".

Replacing the External DC Input Power Fuse

- 1 Remove all power from the 5071A.
- 2 Press down on the top edge of the dc FUSE cap located under the Ext DC Input connector, then grasp the top and bottom of the fuse holder and gently pull it out (back and slightly down). The first fuse to appear is a spare, the one behind it is the active dc fuse element.
- 3 Insert the replacement fuse (5A, 125-volt rating, part number 2110-0838).
- 4 Gently push the fuse holder back into the rear panel.

Internal Standby Battery Maintenance

The 5071A uses two, sealed, 12-Volt lead-acid battery packs as an internal back-up power source. These battery packs are designed specifically for use with the 5071A. The battery's operating time and life can be optimized by understanding and following some guidelines for sealed lead-acid rechargeable batteries.

Battery Shelf Life and Storage

When not in use, the internal standby batteries have a nonlinear self-discharge rate. Additional discharge (always less than 500 microamperes), results from monitor circuits connected across the battery, even when all power to the instrument is removed and the battery disconnect switch has been activated.

Under these conditions (25° C), the useful storage life is roughly three months, does not cause full discharge, and still provides at least 45 minutes of battery operation. The storage time required to deplete all capacity is at least one year. Continued storage beyond one year could jeopardize future battery operation or reduce the remaining number of discharge cycles. For storage times beyond one year, always physically disconnect the batteries from the instrument.

When disconnected, (shelf life at 25° C) the batteries may be stored for up to two years without recharging. The permissible storage temperature range is -65° C to +65° C, with storage life decreasing rapidly as ambient temperature increases.

Battery Operating Temperatures

The battery pack(s) is designed for use between -40° and +65° C. At 25° C, the 5071A is specified to operate for at least 45 minutes, but will typically run for 1 hour. At 0°, the 5071A will typically operate for approximately 50 minutes. At 55° C, the instrument operates between 60 and 75 minutes.

For the operating temperature of 25°, the battery provides 200 cycles of operation with 100% discharge depth for each cycle (when the 5071A automatically shuts down). The battery will provide 2000 cycles of operation at 25° C with 25% discharge depth for each cycle.

The expected battery service life (trickle charged by the internal charger with few discharge cycles) at 23° C is approximately 8 years.

Battery Charging

Lead-acid batteries are designed for occasional usage and long periods of continual trickle charging currents. Unlike Nickel-cadmium batteries, they are not designed for continual deep discharge/charge usage. This makes lead-acid the ideal choice for typical constant operating installations of the 5071A. They will last much longer in a full-charge state and provide more reliable capacity when they are needed.

Because of the long-term storage design of lead-acid batteries, we do not recommend that the 5071A internal batteries be used in situations where power is removed on a daily basis. If this is your situation, the internal batteries will be constantly subjected to discharge and possibly not receive the necessary full 16 hours of re-charge during each typical work day. Such repeated partial charge and discharge cycles can permanently damage the lead-acid battery storage capacity. If you need to operate the 5071A under these conditions, it is recommended that one of the two following processes be used to ensure that the batteries not be stressed by over-use and under-charging.

- Either press the BATTERY DISCONNECT switch on the rear panel each time the power is turned off, or
- Disconnect the battery wires (inside the rear door) to completely remove them from use.

Refer to page 2-17 of this manual for instructions on how to disconnect the batteries.

The rechargeable lead-acid batteries in the 5071A are charged only when the instrument is connected to the ac mains. The typical charging time between a fully discharged state and fully charged state is approximately 16 hours. Shorter charging periods will reduce the operating time you can expect from a single battery charge.

Charging occurs automatically when ac power is connected to the 5071A. The battery is either boost- or trickle-charged depending upon the terminal voltage read by the charging circuit. The charger automatically switches from one state to another as it monitors the battery terminal voltage.

Charging the battery pack(s) outside the instrument with an external charger is not recommended. The 5071A's charging circuit is designed specifically for lead-acid batteries and incorporates temperature-compensated threshold levels to determine the point at which charging rates switch from boost to trickle. These threshold levels are critical to the long-term performance and reliability of the internal battery packs.

WARNING

DO NOT ATTEMPT TO DISASSEMBLE, INCINERATE, OR MUTILATE THE BATTERY PACK(S). THE PACKS MAY BURST OR RELEASE TOXIC MATERIALS. DO NOT CONNECT TOGETHER OR OTHERWISE SHORT-CIRCUIT THE BATTERY TERMINALS; THE PACKS MAY MELT OR CAUSE SERIOUS BURNS.

CAUTION

The 5071A should NOT be operated in a gas-tight enclosure, to minimize the possibility of any hazardous accumulation of hydrogen gas associated with battery overcharging or failure. The possibility of such gaseous accumulation during normal operating circumstances is very remote but requires care as a preventive measure.

Battery Disposal

The spent lead-acid battery pack(s) is considered hazardous waste in some countries. **Dispose only in accordance with local environmental regulations. Contact your nearest regional office of environmental health service for guidance.**

The battery is recyclable as shown by the recyclable symbols that appear on the battery case (see symbol at left). Contact your nearest regional office-of-environmental-health-service for guidance.

Using the Battery Disconnect Switch

Refer to page 2-17, "Disabling the Internal Standby Battery", for information about using the rear-panel Battery Back-up Disconnect switch.

Internal Standby Battery Maintenance

Removing and Replacing the Internal Battery

The batteries are supplied in a nearly-full charged state at instrument shipment. Use ONLY the direct replacement batteries (part number 1420-0514, 2 required) for replacement.

CAUTION

Use of any batteries other than the Battery Pack (part number 1420-0514) may result in damage to your instrument or impaired instrument performance.

Use the following procedure to remove and replace the internal battery pack(s):

- 1** Open the Battery Access Panel on the rear panel of the instrument.
- 2** Carefully disconnect the two battery cables from their mating instrument connections.
- 3** Remove the battery pack(s) by sliding them out of the battery compartment.
- 4** Install the new battery pack(s) by sliding them into the battery compartment.
- 5** Re-connect the battery pack(s) cables to their mating instrument connections.
- 6** Apply ac power to the instrument: the batteries will begin charging.

Cesium Beam Tube Replacement

Refer to the 5071A Assembly-Level Service Manual for information about removal, replacement, and disposal of the Standard or High-Performance Cesium Beam tube.

Long-Term Storage

WARNING

PROLONGED PERIODS OF NON-OPERATION OF THE 5071A CAN RESULT IN DECREASED CESIUM BEAM TUBE LIFE OR PERMANENT TUBE DAMAGE. NEVER STORE THE 5071A LONGER THAN SIX MONTHS WITHOUT PERIODIC (OR CONTINUOUS) OPERATION.

You can safely store the 5071A for extended periods of time by leaving the instrument connected to ac power and placing it into the Standby Mode of operation. (Refer to page 2-15 for details.)

If you need to store the 5071A for extended periods without power, the minimum amount of standby operation time required to maintain the tube's vacuum is 24 continuous hours for each six months of storage time. Remember to physically disconnect the instrument's internal-standby battery before placing the instrument into prolonged un-powered storage (see page 2-17 for more information).

Chapter 7 Installation
Long-Term Storage

A

Performance Tests

Verifying Specifications

Introduction

Introduction

This appendix provides procedures to test the electrical performance of the 5071A Primary Frequency Standard, using the specifications listed in Chapter 6, "Specifications." Three types of tests are provided:

- Operational Verification
- Complete Performance Tests
- RS-232 Verification

Operational Verification

The Operational Verification test is an abbreviated series of checks that may be performed to give a high degree of confidence that the instrument is operating properly without performing the complete Performance Tests. An operational verification is useful for incoming inspection, routine maintenance, and after instrument repair.

Complete Performance Tests

The complete Performance Tests verify the specifications listed in Chapter 6 of this manual. All tests can be performed without access to the inside of the instrument.

RS-232 Verification

The RS-232 Serial Port verification checks the serial port for successful data communication with a terminal or PC.

Test Record

The results of the Operational Verification, complete Performance Tests, and RS-232 Verification should be recorded on a copy of the Performance Test Record, located at the end of this chapter.

Equipment Required

Equipment Required

Equipment required for the performance tests in this chapter is listed in Table A-1. Any equipment that satisfies the critical specification listed in the table may be substituted for the recommended model(s). (The performance test and diagnostic procedures assume the use of the listed equipment.)

If operational verification (OV) or complete-performance tests (P) are being performed, use the test equipment that is indicated for operational verification and/or performance tests in Table A-1.

If diagnostic troubleshooting is required, use the test equipment that is indicated for troubleshooting use in Table A-1.

Table A-1. Recommended Test Equipment

Instrument	Required Characteristics	Use*	Model
General-Purpose Oscilloscope	At least 100 MHz bandwidth Input: 1 M Ω	OV, T	HP/Agilent 54600A
Spectrum Analyzer	Frequency Range Span: 0 to 40 MHz Measurement Resolution 1 kHz/Div. Center Frequency Accuracy: 1 PPM	P, T	HP/Agilent 3585A/B
Linear Phase Comparator	Input Frequency Range: 5 to 10 MHz Input Level (50 Ω): 1 Vrms Output: 0 to +1 Vdc Output Linearity: Proportional from 0 to 360 degrees phase	P	K34-59991A
Strip Chart Recorder	Paper Movement: 1 inch/hour Input Range: 0 to +1 Vdc Full Scale Range: +1 Vdc Full Scale Resolution: 50 minor divisions	P	No Recommendation
Digital Multimeter	Input Resistance: 10 M Ω Accuracy: 0.04% at 1 Vdc	T	HP/Agilent 34401A
40kV ac/dc High Voltage Probe	Range: \leq 5KV dc, input Z = 1 G Ω , Accuracy: 2%, 10 M Ω load	T	34300A
Clip-on Current Probe	Range: \leq 1 Amp dc Output: 1 Vdc at 10 Amp dc	T	HP/Agilent 34302A
Universal Counter	Range: \leq 500 MHz Accuracy: 0.1 PPM	T	HP/Agilent 53131A, Opt 010, 030

Equipment Required**Table A-1. Recommended Test Equipment (Continued)**

Instrument	Required Characteristics	Use*	Model
CW Microwave Counter	Range: ≤ 10 GHz Accuracy: ≤ 0.1 PPM	T	HP/Agilent 5350B, Option 010
Spectrum Analyzer	Frequency Range: ≤ 9.5 GHz Resolution: 100 kHz / Division Center Frequency Accuracy: 1 PPM Input: Up to 1 Watt input capability Dynamic Range: 100 dB	T	HP/Agilent 8566A/B
Input Probe	10:1 Divider (included with 54600A oscilloscope)	T	HP/Agilent 10071A
Input Probe	1:1 1 M Ω (for 50 Ω measurements)	T	HP/Agilent 10070A
RF Signal Generator	Frequency Range: > 80 MHz Power: $\leq +7$ dBm	T	HP/Agilent 8656B
Pulse Generator	Repetition Rate: 10 Hz Pulse Width: ≤ 10 μ sec Output Voltage: $\leq +3$ V	T	HP/Agilent 8111A
General-purpose DC Power Supply,	Adjustable 0 - 10V, ≤ 25 ma	T	HP/Agilent E3610A
IBM-Compatible PC	MS-DOS® 3.3 or later, 640 kB RAM, 1 serial (COM:) Port	T	Any Vendor
Service Accessories Kit	Special Test Tools, Devices, and Fixtures	T	05071-67003
Profiling Software	For Online CBT Performance Testing (included as P/O Service manual)	T	05071-13501
BNC cables	BNC Cables, 50 Ω , 1 meter long, quantity 4	T	10503A
Serial Interface cable	RS-232 Cable, 9-pin (jack) to 9-pin (jack)	T	24542U

Equipment Required**Table A-1. Recommended Test Equipment (Continued)**

Instrument	Required Characteristics	Use*	Model
Adapters	50Ω BNC In-line Feedthrough 2-Way 3dB Power Splitter BNC (jack) to BNC (jack), quantity 4 BNC (jack) to SMC (plug), quantity 2 BNC (plug) to SMC (jack) BNC (jack) to SMB (plug) BNC (plug) to SMB (jack) N (plug) to BNC (jack) N (plug) to SMA (jack) SMA (jack) to SMA (plug) Right-Angle SMA (plug) to SMA (plug) SMA (jack) to SMA (jack) SMB (jack) to SMB (jack) SMB (plug) to SMB (plug) SMC (jack) to SMC (jack) SMC (plug) to SMC (plug)	T	10100C 0960-0496 1250-0080 1250-0832 1250-0831 1250-1236 1250-1857 1250-0780 1250-1250 1250-1249 1250-1159 1250-1158 1250-0672 1250-0669 1250-0827 1250-1113
Microwave Test Cable	SMA (male) at both ends, < 10 dB loss at 10 GHz	T	GoreTex 32R01R01048.0
Special Tools	Narrow bladed non-conducting screwdriver TORX® T-8 Driver TORX® T-10 Driver TORX® T-15 Driver TORX® T-25 Driver	T	Jacobsen #8777 8710-1614 8710-1623 8710-1622 8710-1617
<p>*OV = Operational Verification P = Complete Performance Tests T = Troubleshooting</p>			

5071A Operational Verification

Power-On Self-Tests and Servo Lock

- 1 Inspect the 5071A for any damage (see the section titled Initial Inspection in Chapter 7 for detailed inspection information).
- 2 Ensure that the ac-power setting, ac-line fuse (rear panel), and supplied power cord are appropriate for your ac-power source. (Refer to Chapter 7, “Installation,” for detailed information.)
- 3 Now, apply power to the instrument by connecting ac-power source to the instrument via the ac power cord. The amber Attention light is lit indicating normal power-up sequence and the following messages are displayed on the LCD in sequence:

The message “Waiting for ion pump start” may appear. If so, it could stay on for up to 20 minutes before the following messages appear.

- a. Warming up **(this indicates self-test passed successfully)**
 - b. Lowering E_mult voltage
 - c. Setting Osc. Control
 - d. Setting RF amplitude
 - e. Setting E_mult voltage
 - f. Logging signal levels
 - g. Setting C-field
 - h. Locking servo loops
 - i. Operating normally
- 4 After about 15 minutes (typically), the ATTENTION (amber) light goes out and the CONTINUOUS OPERATION (green) light flashes. This indicates that all servo loops have locked and the instrument is operating normally.

- 5 Press **Shift**, then **5** (Utilities).

LCD display shows RESET.

- 6 Press **Enter**.

This resets the continuous operation circuit, causing the light to be on steadily. Any subsequent fault will cause the Continuous Operation light to go out or flash.

Appendix A Performance Tests
5071A Operational Verification

NOTE

The 5071A will power up at shipment receipt with the following configuration:

Output Ports

Port 1	5 MHz output
Port 2	10 MHz output

RS-232C

Baud rate	2400
Data bits	8
Parity	none
Stop bits	1

System Logs

Printer log	disabled
Error log	lock completed

These first-time power-up configurations can be changed by using the front-panel controls. See the section “Setting the Output Port Frequency” in Chapter 2, “Using the 5071A,” of this manual for instructions on how to perform this.

-
- 7** Mark Pass or Fail on the Performance Test Record, Line 1.

Rear-Panel Output Signal Checks

Check the rear-panel outputs for appropriate signal waveform, frequency and voltage.

Required Equipment

- BNC-to-BNC 1-meter cable (male connectors), model number HP/Agilent 10503A
- Type N (male)-to-BNC (female) adapter, part number 1250-0780
- 50 Ω Feedthrough BNC (male) and (female) adapter, model number HP/Agilent 10100C
- HP/Agilent 54600A General-Purpose 100 MHz Oscilloscope (or equivalent)

To check the rear-panel output connectors quickly for the presence of valid output signals, perform the following:

NOTE

The LCD display backplane light will turn off after approximately 4 minutes to conserve energy if no front-panel key is pressed. Press any key to turn the backplane light back on.

- 1 Connect one of the 5071A outputs to an input channel of the HP/Agilent 54600A with a 50 Ω feedthrough termination and BNC cable as shown in Figure A-1.

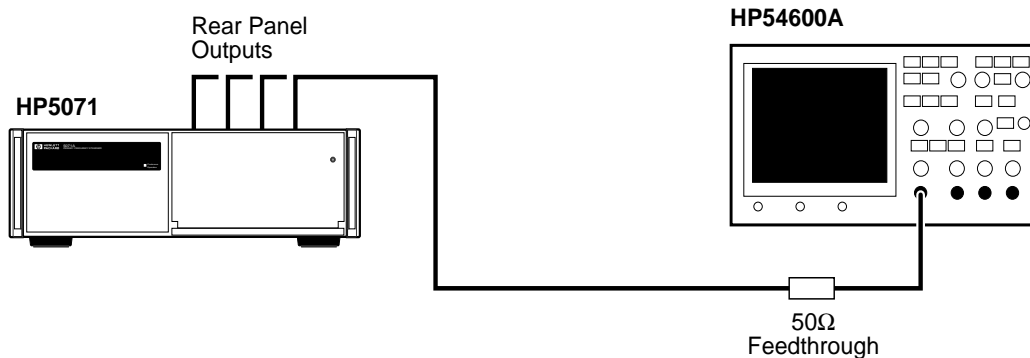

Figure A-1. Rear-Panel Outputs Verification Setup

- 2 On the HP/Agilent 54600A Oscilloscope, press Autoscale.
Use manual settings if needed to check the 1pps Outputs.
- 3 Verify that the output signal waveform, frequency, and nominal voltage correspond to the values listed in Chapter 6, “Specifications,” for the signal under test.
- 4 Repeat steps 1 through 4 for all outputs.
- 5 Mark Pass or Fail on the Performance Test Record, Line 2.

RS-232 Serial Port Verification

- 1 Ensure that the correct hardware connections exist between the 5071A and your terminal, personal computer, or workstation for your remote operation needs as shown in Figure A-2.
- 2 Ensure that the 5071A and your data communications equipment (terminal) are powered-up and have passed their own self-tests.
- 3 On your terminal, press the Enter or Return key several times.
- 4 Observe the returned **scpi>** or **E-xxx>** prompt on the terminal screen.

If the above prompt appears, the RS-232 Verification check passed.

If the prompt does not appear:

- Check and verify all serial port parameters: baud rate, data bits, stop bits, and parity.
 - Check and verify the hardware connections and cabling for correct DTE-DCE signal paths. See the section “Hardware Connection” on page 4-4 in Chapter 4 of this manual for serial-port pin assignments.
 - Check and verify all cables and connections for open or shorted lines.
- 5 Mark Pass or Fail on the Performance Test Record, Line 3.

Appendix A Performance Tests
RS-232 Serial Port Verification

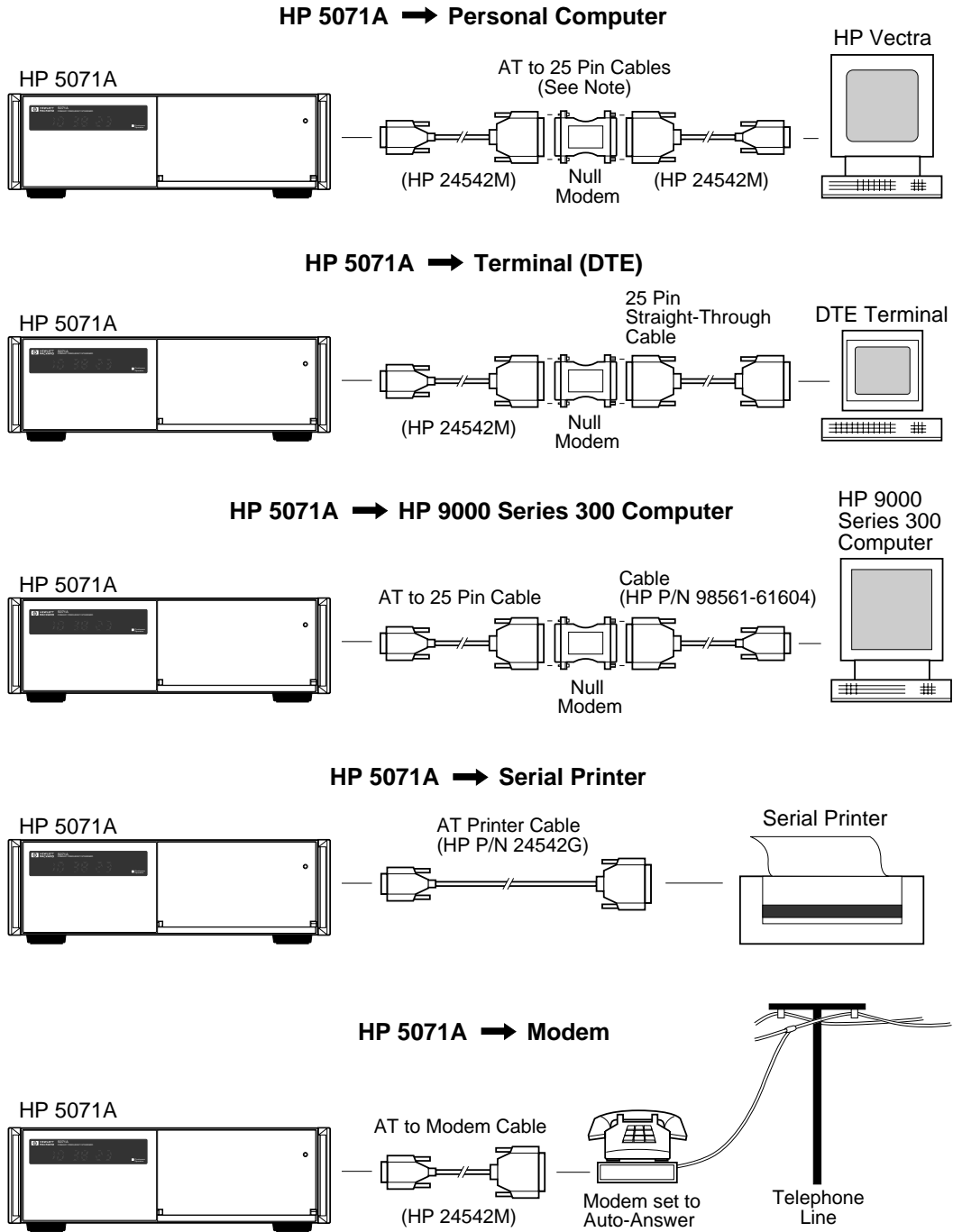

Note: The HP 24542M cables and Null Modem may be replaced by a single HP 24542H cable.

Figure A-2. RS-232C Cabling Setups

5071A Complete Performance Tests

Before performing the following tests, the 5071A under test must have been in operation for at least 30 minutes. If you are initially starting the 5071A, follow the instructions in the subsection “Power-On Self-Tests and Servo Lock” on page A-6 of the Operational Verification section in this appendix.

Test 1— Output Signals: Harmonic Distortion and Spurious Signals Check

A. Harmonic Distortion Check for the 5 and 10 MHz Outputs

Harmonics on the 10 MHz and 5 MHz output signals must be more than 40 dBc below the fundamental. To perform this check, a spectrum analyzer is tuned to the fundamental frequency and an amplitude reference is established. The output frequency spectrum is then examined to determine fundamental-to-sideband amplitude relationship at harmonic points of the fundamental.

Equipment

HP/Agilent 3585B Spectrum Analyzer

Setup

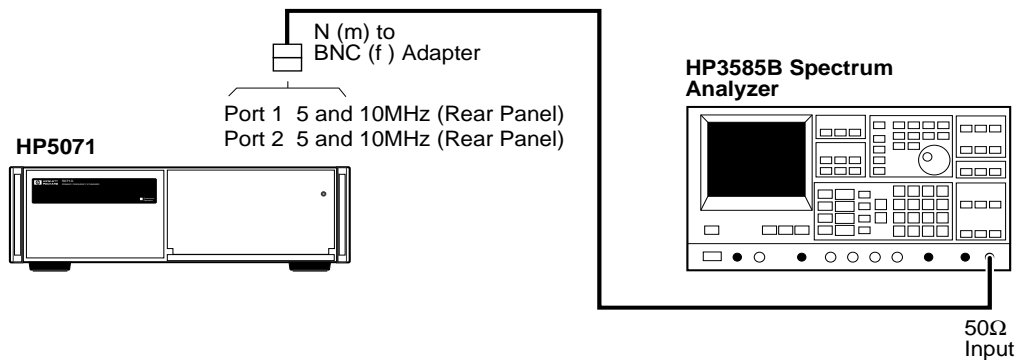

Figure A-3. Harmonic Distortion Test Setup

Specifications

Verify all harmonics are < -40 dBc with respect to the fundamental frequency.

5071A Complete Performance Tests**Procedure**

If you are using the HP/Agilent 3585B Spectrum Analyzer, follow the steps below to test for harmonic signals on the 5 and 10 MHz outputs. If you are using a different spectrum analyzer, use these steps as a guide for operation of that analyzer.

- 1** Connect the 5071A Port 1 to the 3585B analyzer as shown in Figure A-3. Set the 3585B for 50 Ω input impedance.
- 2** On the 5071A, set output ports 1 and 2 to 10 MHz using the front-panel controls. See the section “Setting the Output Port Frequency” in Chapter 2, “Using the 5071A,” of this manual for instructions on how to perform this.
- 3** On the 3585B, perform the following steps:
 - a.** Press the green INSTR PRESET button and allow the analyzer to go through its auto range algorithm (this takes about 5 seconds).
 - b.** Press the DISP LINE (display line) button in the marker menu and adjust the line to -40.0 dBc.
 - c.** Press the PEAK SEARCH button and then the MKR->REF LVL button (both are in the marker menu area).
 - d.** Set both the resolution bandwidth (RES BW) and the video bandwidth (VIDEO BW) to 1 kHz. Enter the 1 kHz values using the numeric and unit keys. The RES BW and VIDEO BW values are displayed at the bottom of the screen.

NOTE

The sweep time is 125 seconds. DO NOT adjust the sweep time manually.

- e.** Press the CONT button in the sweep menu area to begin a new sweep.
- f.** When the new sweep has passed through the fundamental frequency, press the PEAK SEARCH button again. Then press the OFFSET and the ENTER OFFSET buttons in the marker menu area. Verify that both the offset frequency (Hz) and the offset level (dB) go to zero (0 Hz and 0 dB should be displayed at the top of the screen). If necessary, press and hold the ENTER OFFSET button to zero-out the marker offsets.

5071A Complete Performance Tests

When at least one sweep has completed, verify that there are no harmonic signals on or above the -40 dBc display line. Use the knob in the marker area to move the offset marker to any harmonic signal that you want to measure or record. The marker shows the offset frequency and level in dBc from the output signal at 5 or 10 MHz. Verify that there are no harmonically related signals on or above -40 dBc within 5 harmonics of the fundamental.

- 4 On the 5071A, set output ports 1 and 2 to 5 MHz using the front panel controls.
- 5 Repeat step 3.
- 6 Connect 5071A Port 2 to the 3585B Spectrum Analyzer and repeat steps 2 through 5 to test Port 2.
- 7 Record the actual reading in the appropriate place in the Performance Test Record.

B. Non-Harmonic (Spurious) Signal Check for the 5 and 10 MHz Outputs

Non-harmonically related (spurious) signals on the 5 and 10 MHz outputs must be more than 80 dBc below the output signal levels. To perform this test, a spectrum analyzer is tuned to the 5 or 10 MHz signal and an amplitude reference is established. The output frequency spectrum is then examined at 1 MHz on either side of the center frequency to determine the fundamental-to-sideband amplitude relationship for any signals occurring within this range.

Equipment

HP/Agilent 3585B Spectrum Analyzer

Setup

Figure A-4. Non-Harmonic Distortion Test Setup

5071A Complete Performance Tests**Specifications**

All spurious nonharmonic signals must be < -80 dBc with respect to the fundamental frequency.

Procedure

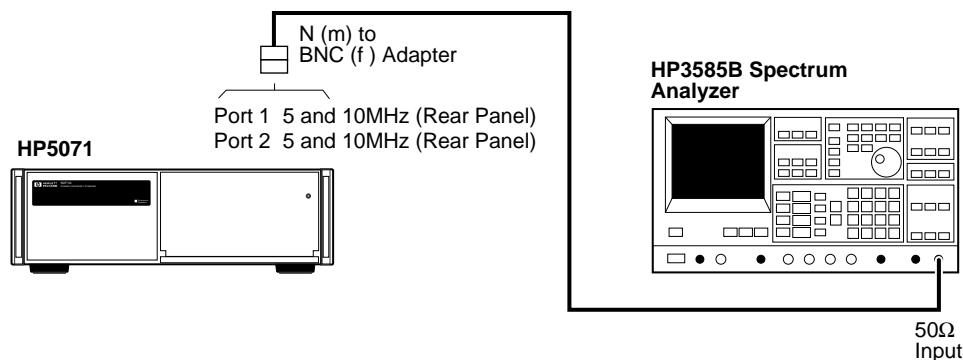
If you are using the HP/Agilent 3585B Spectrum Analyzer, follow the steps below to test for spurious signals on the 5 and 10 MHz outputs. If you are using a different spectrum analyzer, use these steps as a guide for operation of that analyzer.

- 1** Connect the 5071A Port 1 to the 3585B analyzer as shown in Figure A-4. Set the 3585B for 50 Ω input impedance.
- 2** On the 5071A, set output ports 1 and 2 to 10 MHz using the front-panel controls. See the section “Setting the Output Port Frequency” in Chapter 2, “Using the 5071A,” of this manual for instructions on how to perform this.
- 3** On the 3585B, perform the following steps:
 - a.** Press the green INSTR PRESET button and allow the analyzer to go through its auto range algorithm (this will take about 5 seconds).
 - b.** Press the DISP LINE (display line) button in the marker menu and adjust the line to -80.0 dBc.
 - c.** Press the PEAK SEARCH button and then the MKR->REF LVL button (both are in the marker menu area).
 - d.** Set both the resolution bandwidth (RES BW) and the video bandwidth (VIDEO BW) to 1 kHz. Enter the 1 kHz values using the numeric and unit keys. The RES BW and VIDEO BW values are displayed at the bottom of the screen.

NOTE

The sweep time is 125 seconds. DO NOT adjust the sweep time manually.

- e.** Press the CONT button in the sweep menu area to begin a new sweep.
- f.** When the new sweep has passed through the fundamental frequency, press the PEAK SEARCH button again. Then press the OFFSET and the ENTER OFFSET buttons in the marker menu area. Verify that both the offset frequency (Hz) and the offset level (dB) go to zero (0 Hz and 0 dB should be displayed at the top of the screen). If necessary, press and hold the ENTER OFFSET button to zero-out the marker offsets.

5071A Complete Performance Tests

When at least one sweep has completed, verify that there are no spurious signals on or above the -80 dBc display line. Use the knob in the marker area to move the offset marker to any spurious signal that you want to measure or record. The marker shows the offset frequency and level in dBc from the output signal at 5 or 10 MHz.

g. Verify that one of the following conditions is true:

1.No spurious signals are on or above the -80 dBc display line between 4 MHz and 6 MHz for the 5 MHz output, or

2.No spurious signals are on or above the -80 dBc display line between 9 MHz and 11 MHz for the 10 MHz output.

- 4** On the 5071A, set output ports 1 and 2 to 5 MHz using the front-panel controls.
- 5** Repeat step 3.
- 6** Connect 5071A Port 2 to the 3585B Spectrum Analyzer and repeat steps 2 through 5 to test Port 2.
- 7** Record the actual reading in the appropriate place in the Performance Test Record.

C.Harmonic Distortion Check for the 1 MHz Output

Harmonics on the 1 MHz output signal must be more than 40 dBc below the fundamental. To perform this check, a spectrum analyzer is tuned to the fundamental frequency and an amplitude reference is established. The output frequency spectrum is then examined to determine the fundamental-to-sideband amplitude relationship at harmonic points of the fundamental.

Equipment

HP/Agilent 3585B Spectrum Analyzer

Setup

Figure A-5. 1MHz Output Harmonic Distortion Test Setup

5071A Complete Performance Tests

Specifications

All harmonics must be < -40 dBc with respect to the fundamental frequency.

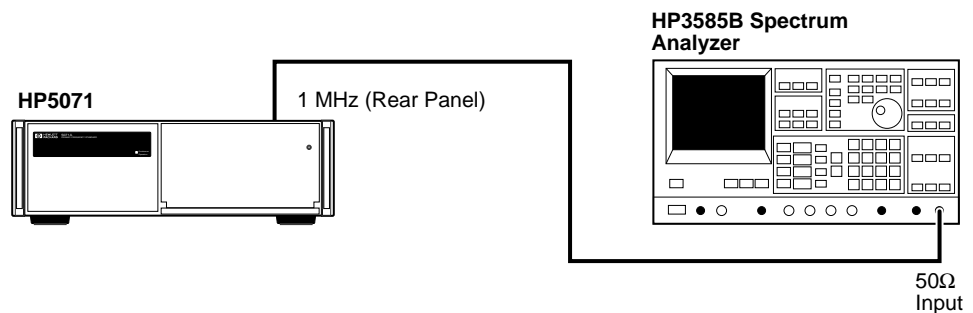
Procedure

If you are using the HP/Agilent 3585B Spectrum Analyzer, follow the steps below to test for harmonic signals on the 1 MHz output. If you are using a different spectrum analyzer, use these steps as a guide for operation of that analyzer.

- 1** Connect the 5071A 1 MHz output to the 3585B Spectrum Analyzer as shown in Figure A-5. Set the 3585B for 50 Ω input impedance.
- 2** On the 3585B, perform the following steps:
 - a.** Press the green INSTR PRESET button and allow the analyzer to go through its auto range algorithm (this will take about 5 seconds).
 - b.** Press the STOP FREQ button. Then set the stop frequency to 20 MHz using the numeric and unit keys in the entry menu.
 - c.** Press the DSP LINE button and move the display line to -40.0 dBc.
 - d.** Press the PEAK SEARCH button, then the MKR->REF LVL button.
 - e.** When the new sweep has passed through the fundamental frequency, press the OFFSET and the ENTER OFFSET buttons in the marker menu area. Verify that both the offset frequency (Hz) and the offset level (dB) go to zero (0 Hz and 0 dB should be displayed at the top of the screen). If necessary, press and hold the ENTER OFFSET button to zero-out the marker offsets.
 - f.** When at least one sweep has completed, verify that there are no signals on or above the -40 dBc display line at multiples of 1 MHz up to 4 MHz. Use the knob in the marker area to move the offset marker to any signals within this range if you want to measure or record these signals. The marker shows the offset frequency and level in dBc from the 1 MHz signal.
- 3** Record the actual reading in the appropriate place in the Performance Test Record.

5071A Complete Performance Tests***D. Harmonic Distortion Check for the 100 kHz Output***

Harmonics on the 100 kHz output signal must be more than 40 dBc below the fundamental. To perform this check, a spectrum analyzer is tuned to the fundamental frequency and an amplitude reference is established. The output frequency spectrum is then examined to determine fundamental-to-sideband amplitude relationship at harmonic points of the fundamental.

Equipment

HP/Agilent 3585B Spectrum Analyzer

Setup

Figure A-6. 100 kHz Harmonic Distortion Test Setup

Specifications

All harmonics must be < -40 dBc with respect to the fundamental frequency.

Procedure

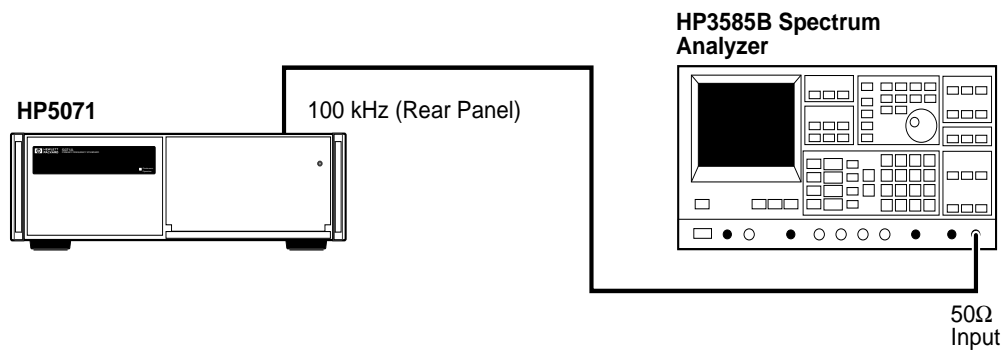
If you are using the HP/Agilent 3585B Spectrum Analyzer, follow the steps below to test for harmonic signals on the 100 kHz output. If you are using a different spectrum analyzer, use these steps as a guide for operation of that analyzer.

- 1 Connect the 5071A 100 kHz output to the 3585B Spectrum Analyzer as shown in Figure A-6. Set the 3585B for 50Ω input impedance.

5071A Complete Performance Tests

- 2** On the 3585B, perform the following steps:
 - a.** Press the green INSTR PRESET button and allow the analyzer to go through its auto range algorithm (this will take about 5 seconds).
 - b.** Press the STOP FREQ button. Then set the stop frequency to 3 MHz using the numeric and unit keys in the entry menu.
 - c.** Press the DSP LINE button and move the display line to -40.0 dBc.
 - d.** Press the PEAK SEARCH button, then the MKR->REF LVL button.
 - e.** Set the resolution bandwidth (RES BW) to 300 Hz and the video bandwidth (VIDEO BW) to 1 kHz.

NOTE

The sweep time is 66.8 seconds. DO NOT adjust the sweep time manually.

- f.** Press the CONT button in the sweep menu area to begin a new sweep.
 - g.** When the new sweep has passed through the fundamental frequency, press the OFFSET and the ENTER OFFSET buttons in the marker menu area. Verify that both the offset frequency (Hz) and the offset level (dB) go to zero (0 Hz and 0 dB should be displayed at the top of the screen). If necessary, press and hold the ENTER OFFSET button to zero-out the marker offsets.
 - h.** When at least one sweep has completed, look for any signals that appear on or above the -40 dBc display line at multiples of 100 kHz up to 500 kHz. Use the knob in the marker area to move the offset marker to any signals within this range if you want to measure or record these signals. The marker shows the offset frequency and level in dBc from the 100 kHz signal.
- 3** Record the actual reading in the appropriate place in the Performance Test Record.

5071A Complete Performance Tests**Test 2 — Frequency Accuracy**

The following accuracy check measures the changing phase relationship between the 5071A 10 MHz output and another primary frequency standard (5071A Primary Frequency Standard or better). An HP/Agilent K34-59991A Linear Phase Comparator is used to measure the phase between the 5071A under test and the reference standard.

NOTE

In this test, the reference standard must be of known accuracy. The measurement time must be of sufficient length so the accuracy of the measurement is not impaired by the stability of either the reference standard or the unit under test. If the reference standard is an 5071A with Option 001, the accuracy measurement must be made for 24 hours if the unit under test is a standard unit. The test can be made in 2 1/2 hours if the unit under test has Option 001 (High Performance Cesium Beam Tube).

Equipment

HP/Agilent
K34-59991A

Linear Phase Comparator

Strip Chart Recorder

Setup

Figure A-7. Frequency Accuracy Test Setup

Specifications

Standard Unit: $\pm 1 \times 10^{-12}$

Option 001: $\pm 5 \times 10^{-13}$

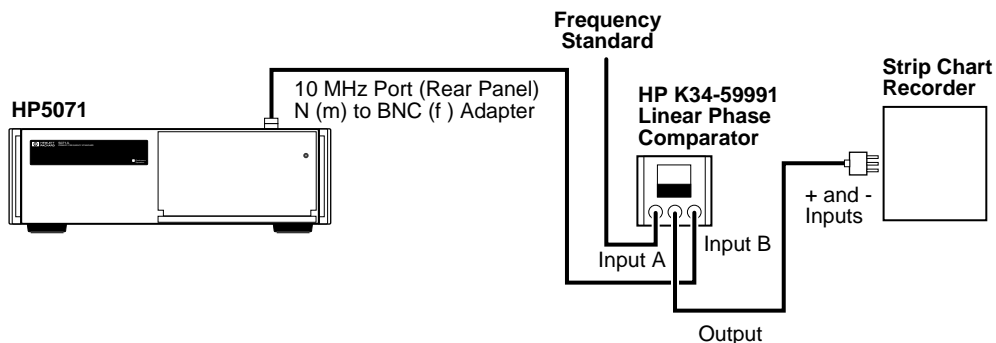
NOTE

The accuracy of the 5071A is better than 5×10^{-13} (Option 001) or 1×10^{-12} (standard unit). Be sure the accuracy of the reference standard is known with sufficient precision to make this measurement accurately.

Procedure

- 1** The 5071A must be on for at least 30 minutes and the green continuous operation LED must be on.
- 2** Connect the HP/Agilent K34-59991A Phase Comparator OUTPUT terminals to the strip chart recorder as shown in Figure A-7. Set the recorder for 1V full scale and 1 inch/hour, and turn on the recorder.
- 3** Turn on the K34-59991A power.
- 4** Connect the 10 MHz reference to INPUT A and the 5071A (unit under test) 10 MHz to INPUT B as shown in Figure A-7.
- 5** Set K34-59991A ZERO-OPER-FULL front panel mounted toggle switch to ZERO. Adjust the ZERO SCALE control for a zero reading on the meter. Then adjust the recorder for a zero indication.
- 6** Set K34-59991A switch to FULL and adjust FULL SCALE control for a full scale reading on the recorder.
- 7** Check both ZERO and FULL SCALE settings on the recorder and readjust if necessary.
- 8** Set K34-59991A switch to OPER for normal operation.
- 9** The recorder now provides a continuous record of the phase difference between the reference standard and the 5071A unit under test. When its output reaches full scale (360 degrees), the K34-59991A will automatically reset to 0 (0 degrees).
- 10** With the recorder set as described, the phase record is 100 ns full scale (with 10 MHz inputs). The figure below shows an example of a frequency difference measurement under these conditions.

Appendix A Performance Tests
5071A Complete Performance Tests

- 11** The frequency difference between the unit under test and the reference is given by the following equation:

$$\Delta f/F = \Delta t/T$$

Where,

$\Delta f/F$ is the desired frequency difference, and Δt is the phase change (in seconds) over the measurement time, T .

The Figure A-8 shows a typical plot using the strip chart recorder.

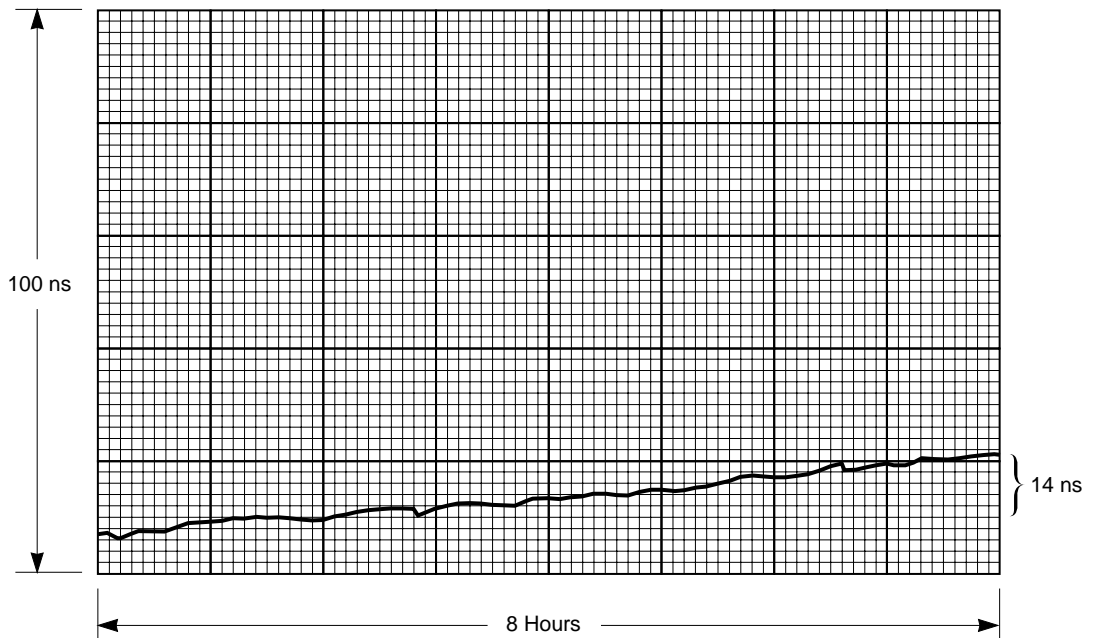

Figure A-8. Error Measurement

In the example, the frequency difference, $(\Delta f)/F$, is computed as follows:

$$\Delta f/F = \Delta t/T$$

$$= (7 \text{ minor divisions} \times 2 \times 10^{-9} \text{ seconds/minor divisions})$$

$$= 14 \times 10^{-9} \text{ seconds}$$

$$T = 8 \text{ hours or } 2.88 \times 10^4 \text{ seconds}$$

$$\Delta f/F = \Delta t/T = 14 \times 10^{-9} / 2.88 \times 10^4$$

$$= 4.9 \times 10^{-13} \text{ or } 4.9 \text{ parts in } 10^{13}$$

5071A Complete Performance Tests

This shows that frequency difference between the unit under test and the reference is **4.9** parts in ten to the 13th. This is only an example. The measured frequency accuracy of an 5071A should be 1×10^{-12} or better for a standard unit, or 5×10^{-13} or better for a high performance unit (Option 001). Note the final computation should include the accuracy of the reference source.

- 12** Record the actual reading in the appropriate place in the Performance Test Record.

Test 3 — Stability

NOTE

High accuracy precision measurements of time stability are available through the National Institute of Standards and Technology (NIST) in the USA. NIST can completely characterize and verify all major specifications of the 5071A. For information regarding the various tests available, contact:

M.C. 847.4
National Institute of Standards and Technology
325 Broadway
Boulder CO 80303-3328
USA
Telephone: (303) 497-3753

A. Time Domain

This is an engineering-level measurement requiring a special test setup. The test setup must be carefully designed to eliminate all sources of noise. For more information on how to make this measurement, see Application Note 358-12.

Also, see NIST Technical Note 1337 (available from US Government Printing Office, Washington DC., USA). This is an excellent theoretical as well as technical reference for this measurement.

Record the actual reading in the appropriate place in the Performance Test Record. This completes the performance test.

B. Frequency Domain

This measurement requires the 3048A Phase Noise Measurement System, a highly specialized test system. In order to perform properly, this system must contain a reference oscillator with phase noise characteristics that are equal to or better than the 5071A. Instructions for performing frequency domain stability tests can be found in the HP/Agilent 3048A system documentation.

Record the actual reading in the appropriate place in the Performance Test Record.

5071A PERFORMANCE TEST**5071A PERFORMANCE TEST**

Model 5071A Primary Frequency Standard			
Serial Number: _____		Repair/Work Order No. _____	
Test Performed By: _____		Temperature: _____	
Date: _____		Relative Humidity: _____	
Notes: _____			
Line Number	Operational Verification	Test Results	
		Pass	Fail
1	Power-On Self-Tests/Servo Lock	_____	_____
2	Rear-Panel Output Signal Checks	_____	_____
3	RS-232 Serial Port Verification	_____	_____
5071A Complete Performance Tests			
Test Number	Test Description	Actual Reading	Limits
1	Output Signals: Harmonic Distortion and Spurious Signals Check		
	A. Harmonic Distortion Check for the 5 and 10 MHz Outputs	_____	Greater than 40 dBc
	B. Non-harmonic (Spurious) Signal Check for the 5 and 10 MHz Outputs	_____	Greater than 80 dBc
	C. Harmonic Distortion Check for the 1 MHz Output	_____	Greater than 40 dBc
	D. Harmonic Distortion Check for the 100 kHz Output	_____	Greater than 40 dBc
2	Frequency Accuracy	_____	Standard Unit: $\pm 1 \times 10^{-12}$ Option 001: $\pm 5 \times 10^{-13}$
3	Stability		See Specifications in Chapter 6 of this manual.
	A. Time Domain	_____	
	B. Frequency Domain	_____	

5071A PERFORMANCE TEST

B

Glossary

5071A Glossary

Accuracy The degree to which the 5071A output frequency differs from that of the accepted definition. The currently-accepted definition is that of the 13th General Conference of Weights and Measures and is based on Cesium (The hyperfine resonance of the Cesium 133 atom in zero magnetic field is 9.192631770 GHz.). In practice, this involves comparison with some generally-accepted physical embodiment of this definition such as one of the time standards in the international time scale (TIA) monitored by the BIH (Bureau International L'Heure) in Paris, France. The specified accuracy of the 5071A is intrinsic and is maintained without calibration.

Epoch (Time) A selected instant in time, used as a reference point.

Flicker Floor The level at which the Allan variance time domain stability measurement remains constant with increased averaging time. The Allan Variance statistical method for measuring time domain stability responds in several ways to various noise processes in a cesium standard. Many of these noise processes produce contributions which average out or decrease as the averaging time increases. Flicker noise, on the other hand, gives rise to an Allan variance independent of averaging time. Thus, the Allan variance of a typical frequency standard will decrease with increasing time, until a relatively constant value is reached. This value is known as the *flicker floor*.

Frequency Domain Stability (also called single-sideband phase noise or additive noise). Describes the spectral noise in the specified

output signal caused by phase modulation from internal noise sources. The measurement is normalized by expressing the ratio of noise power (in a 1-Hz bandwidth) to the signal power, then measured as a function of offset from that signal.

For more information see NIST Technical Note 1337, Characterization of Clocks and Oscillators available from the Superintendent of documents, U.S. Government Printing Office, Washington DC 20402-9325.

Isolation The degree to which one output of the 5071A is affected by changes in loading on another output of the same standard. In practice, this represents a change in amplitude, frequency, or phase as seen at one terminal due to the effect of placing a short, open, or reactance on another terminal. In the 5071A, both the Port 1 and Port 2 high isolation output frequencies are derived from the same source; there is no measurable change in frequency. The change in amplitude or phase is measured as the level of the sideband at one port, which results from applying and removing the load at a low frequency rate at the other port. The measurement is the level of the resulting sideband compared to the nominal output level, expressed in decibels.

Reproducibility The degree to which the 5071A will reproduce the same frequency from one occasion to another after an interruption in operation. This does not include any calibration procedure but may require degaussing.

5071A Glossary

Short-Term Stability See Time Domain Stability.

Standards —

- *House*: The most stable and accurate frequency source available as a reference within the user's facility. Usually kept referenced to national frequency standards.
- *Reference/Transfer*: The reference standard used to transfer frequency or time from the house standard to working standards.
- *Working*: The standard against which instruments are compared for test or repair purposes.

Stability The degree to which the frequency of the 5071A may be adjusted to correspond with a reference without loss of stability.

Time Domain Stability (also called short-term stability); The standard deviation of fractional frequency fluctuations in the specified output signal due to random noise in the cesium standard. The mathematical method by which it is calculated is called the Root Allan Variance. Symbolically, it is represented by the term $\sigma_y(2, \tau)$ where σ_y is the standard deviation, 2 means that measurements are taken in pairs, and τ is the measurement time.

In the 5071A specifications, values for all averaging times are shown in one chart for convenience. However, short-term stability specifications for averaging times in excess of 1000 seconds are valid only under laboratory conditions (temperature $25 \pm 5^\circ \text{C}$, relative humidity $45\% \pm 10\%$). For more information on time domain stability, see NIST Technical Note 1337, Characterization of Clocks and Oscillators available from the Superintendent of documents, U.S. Government Printing Office, Washington D.C. 20402-9325.

Time Interval Time between events.

UTC Coordinated Universal Time; An internationally agreed-upon time scale having the same rate as Atomic Time. UTC is corrected in one-second step adjustments, as needed, to remain within 0.7 seconds of Astronomical Time

UT1 A non uniform time scale based on the earth's rotation and corrected for the effects of polar motion.

Index

NUMERICS

1PPS output, 1-2, 2-6

A

Ac power

- cabling, 8-6
- line fuse, 8-5
- power cord, 8-6
- selecting voltage, 8-5
- voltage, 8-4

Accuracy and stability, 6-3

ACTIONS keypad, 1-2, 2-4

Add a frequency offset, 2-12

Adjusting front-panel LCD display, 1-8

Assessing operational status, 3-8

Attention light, 1-2, 3-3

Auxiliary dc power requirements, 8-4

Available

- ac power cables, 8-6

B

Battery

- access panel, 8-16
- charging, 8-14
- connections, 2-17
- disposal, 8-15
- operating temperatures, 8-13
- removal and replacement, 8-16
- shelf life and storage, 8-13

Baud rate

- data, 4-3

C

Cesium beam tube

- life, 3-10
- replacement, 8-17

Clock display, 2-8

CLOCK menu, 3-8

CONFIGuration menu, 3-8

Configure the HP 5071A, 2-15

Connector descriptions, 1-5

Continuous operation light, 1-2, 3-3

- reset, 2-14

D

Data entry keypad, 1-2, 2-4

Dc power

- operation, 8-11
- power requirements, 8-4
- voltage, 8-4

Diagnostic commands, 5-9

Diagnostic self-tests, 2-14

Disabling the internal back-up

- battery, 2-17

Display commands, 5-14

E

Error messages, 5-37

Event log, 2-11

External dc power

- operation, 8-11
- power requirements, 8-4
- voltage, 8-4

F

Front-panel status lights, 3-4

Front-panel warning messages, 3-6

Fuse

- ac power, 8-5
- dc power, 8-12

G

Glossary, B-2

I

INFORMATION menu, 3-8

Installation

- rack-mount, 8-7

Instrument

- specifications
 - accuracy and stability, 6-3
 - supplemental characteristics, 6-6

Instrument states, 3-5

L

Leap second insertion, 4-20

Leap second scheduling, 2-9

LOG menu, 3-8

M

Maintenance

- operator, 8-11

Messages, error, 5-37

Modem operation, 4-8

Monitor status

- interpret results, 2-10
- print report, 2-10
- select parameters, 2-10

O

Operating specifications and characteristics, 6-3, 6-5

Operational verification, A-6

Operator maintenance, 8-11

Output port frequency, 2-5

P

Performance tests

- equipment required, A-3
- frequency accuracy, A-19

Index

- harmonic distortion and spurious signals, A-11
- stability, A-22
- Precision time commands, 5-15
- Printer
 - interface, 5-35
 - setup, 4-3

R

- Rack-mount installation, 8-7
- Rear-panel output checks, A-8
- Rear-panel status output
 - reset, 2-14
- Reference oscillator commands, 5-19
- Replacing the ac power fuse, 8-5
- Replacing the dc power fuse, 8-12
- Restarting the HP 5071A, 3-9
- RS-232
 - default values, 4-6
 - serial port verification, A-9

S

- SCPI command summary, 5-5
- Serial port, 2-16, 4-3
 - configuration, 4-6
 - pin assignments, 4-4
- Set the 1PPS output, 2-6
- Set the date, 1-9
- Set the output port frequency, 2-5
- Set the time, 1-9
- Specifications
 - accuracy and stability, 6-3
 - supplemental characteristics, 6-6
- Starting the HP 5071A, 1-6
- Status lights, 3-4
- Status monitoring commands, 5-21
- Storage, 8-17
- Sync input, 1-2
- Synchronize to external reference, 1-8
- Synchronize using a time-interval counter, 2-6
- System commands, 5-26

T

- Turn on clock display, 2-8

U

- UTILities menu, 3-8

W

- Warning messages, 3-6

Service and Support

Contacting Agilent Technologies:

For more information about Agilent test and measurement products, applications, and services, visit our web site at <http://www.agilent.com/services/English/index.html>.

Agilent's Test and Measurement Fax Service for United States and Canada:

Technical information for test and measurement products and services is available 24 hours a day, 7 days a week, by calling **1-800-800-5281**.

Technical Support:

If you need technical assistance with an Agilent test and measurement product or application, you can find a list of local service representatives on the web site listed above. If you do not have access to the Internet, one of the following centers can direct you to your nearest representative:

Asia Pacific:

Hong Kong, SAR

Tel: (852) 2599-7777

Fax: (852) 2506-9284

Australia/New Zealand:

Blackburn, Victoria, Australia

Tel: 1-800-629-485 (Australia)

Tel: 0-800-738-378 (New Zealand)

Fax: (61-3) 9272-0749

Canada:

Mississauga, ON, Canada

Tel: 877-894-4414

Fax: (905) 206-4700

Europe:

European Marketing Organization
The Netherlands

Tel: +31 20 547 9999

Fax: +31 20 547 7799

Japan:

Measurement Assistance Center
Tokyo, Japan

Tel: 81-426-56-7832

Fax: 81-426-56-7843

Latin America:

Latin America Region Headquarters
Miami, FL, U.S.A.

Tel: (305) 267-4245

Fax: (305) 267-4288

United States:

Test & Measurement Call Center
Englewood, CO, U.S.A.

Tel: (800) 452-4844 (Toll free in US)

Fax: (303) 662-3726

Continued from front matter. . .

Warranty (contd)

Agilent does not warrant that the operation of Agilent products will be uninterrupted or error free. If Agilent is unable, within a reasonable time, to repair or replace any product to a condition as warranted, customer will be entitled to a refund of the purchase price upon prompt return of the product.

Agilent products may contain remanufactured parts equivalent to new in performance or may have been subjected to incidental use.

The warranty period begins on the date of delivery or on the date of installation if installed by Agilent. If customer schedules or delays Agilent installation more than 30 days after delivery, warranty begins on the 31st day from delivery.

Warranty does not apply to defects resulting from (a) improper or inadequate maintenance or calibration, (b) software, interfacing, parts or supplies not supplied by Agilent, (c) unauthorized modification or misuse, (d) operation outside of the published environmental specifications for the product, or (e) improper site preparation or maintenance.

TO THE EXTENT ALLOWED BY LOCAL LAW, THE ABOVE WARRANTIES ARE EXCLUSIVE AND NO OTHER WARRANTY OR CONDITION, WHETHER WRITTEN OR ORAL, IS EXPRESSED OR IMPLIED AND AGILENT SPECIFICALLY DISCLAIMS ANY IMPLIED WARRANTIES OR CONDITIONS OF MERCHANTABILITY, SATISFACTORY QUALITY, AND FITNESS FOR A PARTICULAR PURPOSE.

Agilent will be liable for damage to tangible property per incident up to the greater of \$300,000 or the actual amount paid for the product that is the subject of the claim, and for damages for bodily injury or death, to the extent that all such damages are determined by a court of competent jurisdiction to have been directly caused by a defective Agilent product.

TO THE EXTENT ALLOWED BY LOCAL LAW, THE REMEDIES IN THIS WARRANTY STATEMENT ARE CUSTOMER'S SOLE AND EXCLUSIVE REMEDIES. EXCEPT AS INDICATED ABOVE, IN NO EVENT WILL AGILENT OR ITS SUPPLIERS BE LIABLE FOR LOSS OF DATA OR FOR DIRECT, SPECIAL, INCIDENTAL, CONSEQUENTIAL (INCLUDING LOST PROFIT OR DATA), OR OTHER DAMAGE, WHETHER BASED IN CONTRACT, TORT, OR OTHERWISE.

For consumer transactions in Australia and New Zealand: the warranty terms contained in this statement, except to the extent lawfully permitted, do not exclude, restrict or modify and are in addition to the mandatory statutory rights applicable to the sale of this product to you.

Assistance

Product maintenance agreements and other customer assistance agreements are available for Agilent products.

For any assistance, contact your nearest Agilent Sales and Service Office.

Safety Considerations (contd)

WARNING

ANY INTERRUPTION OF THE PROTECTIVE GROUNDING CONDUCTOR (INSIDE OR OUTSIDE THE INSTRUMENT) OR DISCONNECTING THE PROTECTIVE EARTH TERMINAL WILL CAUSE A POTENTIAL SHOCK HAZARD THAT COULD RESULT IN PERSONAL INJURY. (GROUNDING ONE CONDUCTOR OF A TWO CONDUCTOR OUTLET IS NOT SUFFICIENT PROTECTION.)

Whenever it is likely that the protection has been impaired, the instrument must be made inoperative and be secured against any unintended operation.

If this instrument is to be energized via an autotransformer (for voltage reduction) make sure the common terminal is connected to the earthed pole terminal (neutral) of the power source.

Instructions for adjustments while covers are removed and for servicing are for use by service-trained personnel only. To avoid dangerous electric shock, do not perform such adjustments or servicing unless qualified to do so.

For continued protection against fire, replace the line fuse(s) only with 250V fuse(s) of the same current rating and type (for example, normal blow, time delay). Do not use repaired fuses or short circuited fuseholders.

Acoustic Noise Emissions

LpA<47 dB at operator position, at normal operation, tested per EN 27779. All data are the results from type test.

Geräuschemission

LpA<47 dB am Arbeitsplatz, normaler Betrieb, geprüft nach EN 27779. Die Angaben beruhen auf Ergebnissen von Typenprüfungen.

Electrostatic Discharge Immunity Testing

When the product is tested with 8kV AD, 4kV CD and 4kV ID according to IEC801-2, a system error may occur that may affect measurement data made during these disturbances. After these occurrences, the system self-recovers without user intervention.



Manual Part Number 05071-90041

Printed in U.S.A., DECEMBER 2000