

Contents

Introduction and Product Description 2

E5250A Low Leakage Switch Mainframe 3

E5250A Option 001 10 x 12 Matrix Switch 4

Input/Output Cables and Connector Plates for the E5250A Option 001 7

E5250A Option 501 24 (8 x 3) Channel Multiplexer 8

Typical Applications

- Hot Carrier Induced Degradation 10
- Time Dependent Dielectric Breakdown 11

Input/Output Cables and Connector Plates for the E5250A Option 501 12

Ordering Information 13

Appendix 16



Introduction and Product Description

The Agilent E5250A Low Leakage Switch Mainframe can switch the measurement ports with less performance degradation. This Setup Guide describes the configuration for various applications. It also provides necessary information to order the accessory products.

The Agilent 4155C/4156C and other semiconductor parameter analyzers and semiconductor instruments provide high performance measurement capability. The Agilent E5250A expands the single measurement station to an automated measurement system.

The Agilent E5250A can be configured either for general parametric measurements (with Option 001) with up to 48 outputs or for long term reliability measurements (with Option 501) with up to 384 channels (4 mainframes).

Option 001 10 x 12 Matrix Switch

For sequential measurement of many devices on a test structure, the 10 inputs and 48 outputs provide flexibility and accuracy: two low leakage (100 fA) and four standard inputs for I-V measurements, two C-V paths with accurate capacitance compensation; and two auxiliary inputs for pulsed, differential voltage and other measurements.

Option 501 24 (8 x 3) Channel Multiplexer

The Agilent E5250A is ideal for long term reliability measurements with its 384 channel capability and advanced features typically found only on large, more costly dedicated reliability test systems. Each set of eight channels has a multilevel DC bias input. This allows inexpensive power supplies to be used for consistent stressing. The large number of channels and low-cost stress sources allow the customer to efficiently test hundreds of devices in parallel resulting in both cost and time savings, but still achieve accurate and consistent results.

E5250A Low Leakage Switch Mainframe

The width and height of the E5250A is same as Agilent 4155C/4156C Semiconductor Parameter Analyzer. So, you can easily stack with the instruments. The front panel has a selftest key, power switch, and LED indicators.

All switch control is executed by commands via the built-in GPIB interface. The Agilent 4155C/4156C has control of the Agilent E5250A (E5252A cards only) integrated into the front panel.



Front View

Software

A program disk that includes utilities and sample routines/programs is furnished with Agilent E5250A.

The Capacitance compensation routine is useful for accurate measurement with Agilent 4284A.

Agilent ICS

Besides the furnished software, the Agilent E5230B Interactive Characterization Software is available to provide point and click operation for Agilent E5250A control.



Rear View

E5250A Rear View

E5250A has 4 card slots for inserting the switch options.

The rear panel of the mainframe has 10 input ports. With the switch module options, you can configure a 10 x 48 Matrix Switch or a 96 channel Multiplexer per one mainframe.

When the mainframe is used as a matrix switch, 10 input ports function as 2 low leakage I-V, 4 general I-V, 2 C-V, and 2 HF ports. With Kelvin triaxial cable,

you can measure low voltage or small resistance more accurately. A Kelvin cable occupies two adjacent 2 I-V input ports. When the mainframe is used as a multiplexer, 6 of 10 input ports can be used as low leakage I-V ports, and remaining 4 input ports are not used.

Relay Test Adapter

If you need to test relays on the switch cards, Option 301 Relay Function Test Adapter is available.



E5250A Option 301 Relay Test Adapter

**E5250A Option 001
10 x 12 Matrix Switch**

E5250A Option 001 has 12 triaxial output channels per card and forms a 10 x 12 Matrix Switch configuration with the mainframe. Up to four Option 001 cards can be installed in the four card slots.

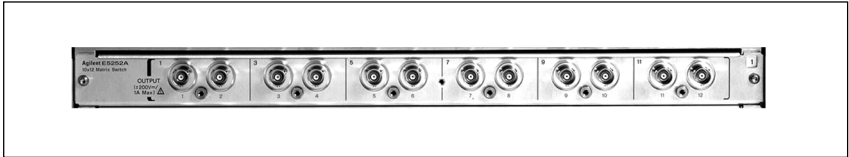

E5250A Option 001 10 x 12 Matrix Switch.

Two adjacent triaxial connectors can be used as a Kelvin connection. If all outputs are Kelvin, then the total number of output channels is 6.

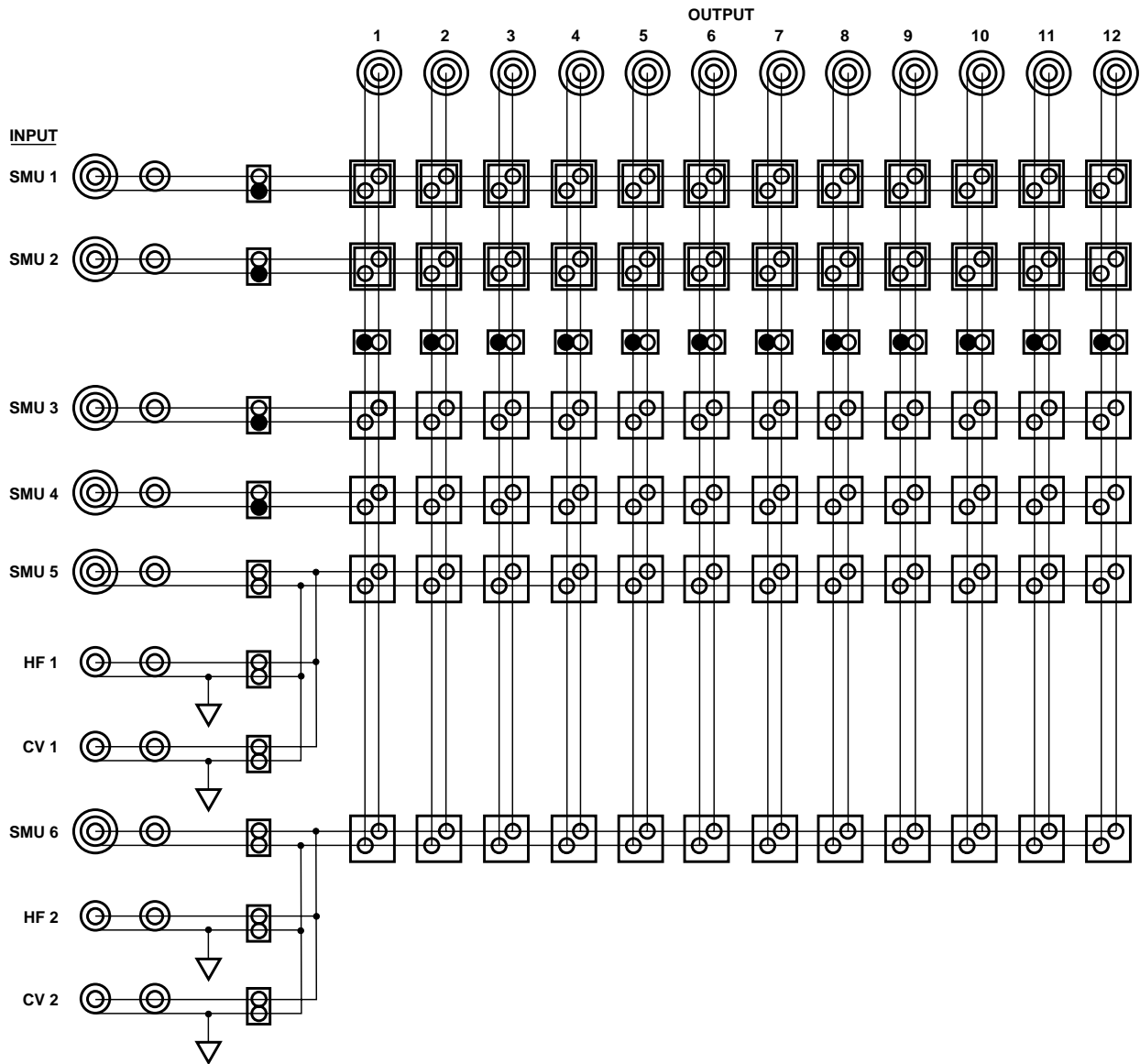

Figure 1. Option 001 block diagram.

The following describe items to consider for complete setting of the system:

Instruments

Agilent 4155C/4156C Semiconductor Parameter Analyzer is best suited for I-V and quasi-static C-V measurement. For high frequency C-V measurement, the Agilent 4284A is the best choice.

Switch Options

Select the number of Option 001s for E5250A by considering maximum pin count that you need. Remember that each Kelvin connection uses two ports.

Wafer Prober

Select a wafer prober for stable and accurate low current measurement. Cascade Microtech, Inc. is one supplier of low current probers with maximum 48 pin count. Or, you can use your prober in a shield box.

Cables between Instruments and E5250A with Option 001

Each I-V instrument furnishes the triaxial cables. Also, you can select suitable cable, triaxial, or Kelvin triaxial, for the Agilent E5250A input ports from the list on page 7. For the Agilent 4284A, you need to use the Agilent 16048D/E test cable with two T-connectors (Agilent P/N 1250-2405). The cable from ground unit is not connected through the E5250A switch.

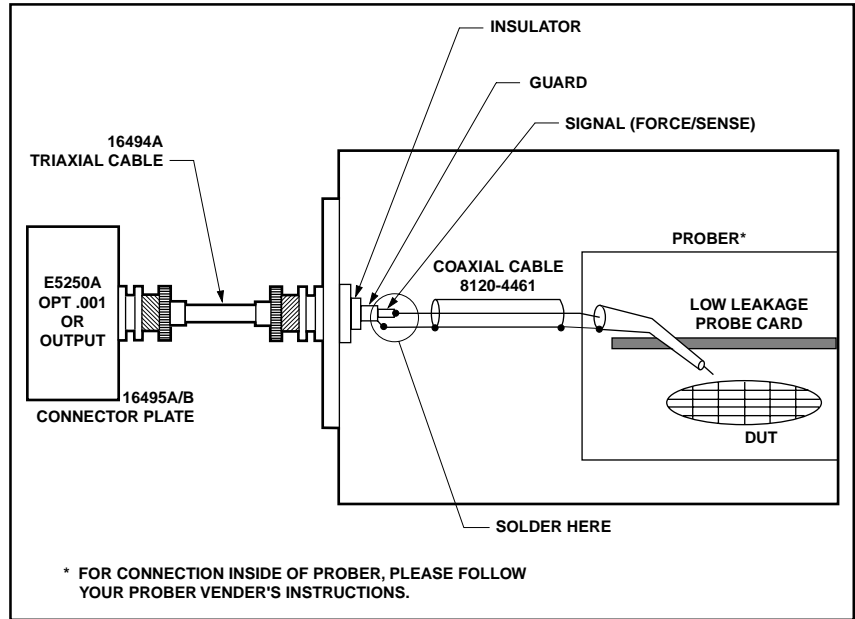

Figure 2. Cabling to prober.

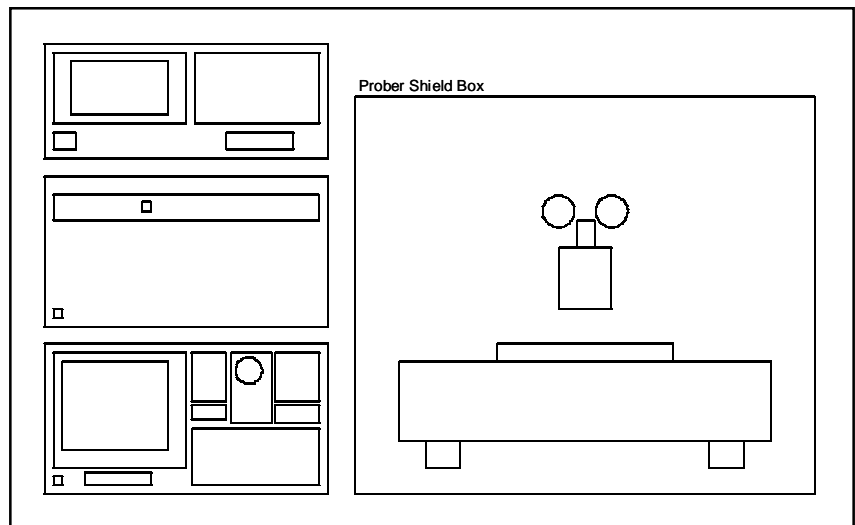

Figure 3. Typical application for Option 001 (front view).

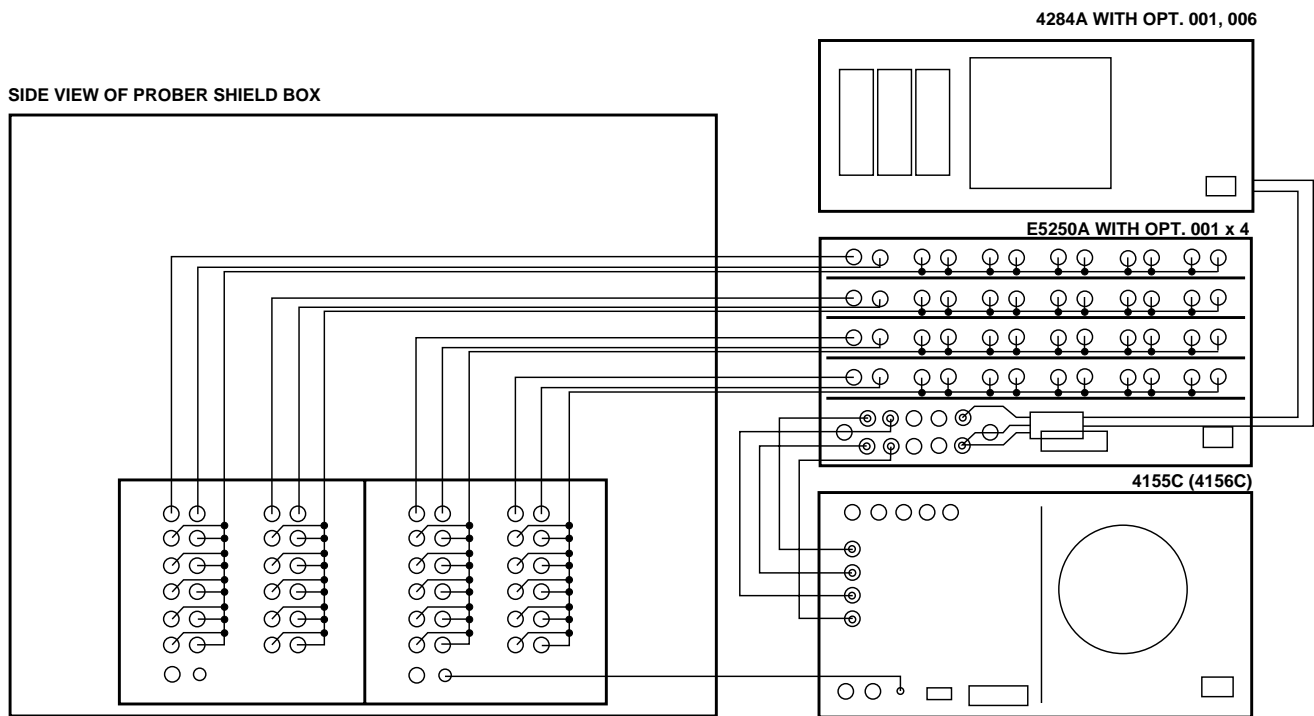

Figure 4. Typical application for Option 001 (rear view).

Connection to Prober

For a dedicated low leakage prober, you can directly connect to the triaxial terminals on the prober. If you use a conventional prober with shield box, you connect the triaxial cables to the connector plate (Agilent 16495A/B) mounted on the shield box. Then, you connect cables from the plate to the probe card.

Cabling to Prober

Figure 1 shows a cabling example. For the cable that connects the connector plates and probe/probe card, Agilent

recommends to use low-noise coaxial cable (Agilent P/N 8120-4461 for switch output, 8120-3674 for GNDU). Solder the cable on both sides.

Typical Application for E5250A Option 001 Matrix Switch

One example of the Option 001 10 x 12 Matrix Switch is general parametric measurement on wafer. Figure 4 shows the interconnection schematic.

This setup allows you to automate the system to measure the parameters of devices such as diodes, MOSFETs, and bipolar transistors on a test structure die.

The maximum 48 output channels should be sufficient for pads on test structure.

Input/Output Cables and Connector Plates for Agilent E5250A Option 001



Agilent 16494A Triaxial Cable
Low noise triaxial cable with male triaxial connectors on both ends. Length: 1.5 m, 3 m, and 80 cm. Above picture shows four Agilent 16494As.

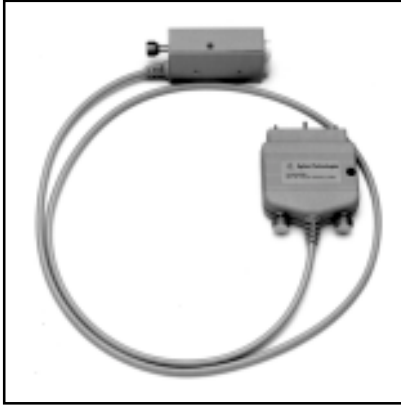

Agilent 16494B Kelvin Triaxial Cable
Low noise Kelvin triaxial cable with sense and force connectors to connect Agilent 4156C and Agilent E5250A. Length: 1.5 m and 3 m.

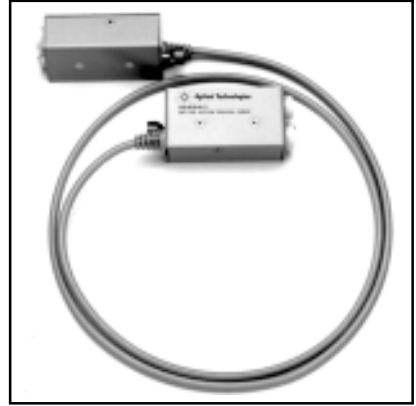

Agilent 16494C Kelvin Triaxial Cable
Low noise Kelvin triaxial cable with sense and force connectors to connect Agilent 4142B and Agilent E5250A. Length: 1.5 m and 3 m.



Agilent 16495A Connector Plate with 12 Triaxial Interlock/GNDU.
Half size connector plate with 12 triaxial female connectors, interlock, and GNDU connector.



Agilent 16495B Connector Plate with 24 Triaxial Interlock/GNDU.
Half size connector plate with 24 triaxial female connectors, interlock, and GNDU connector.



Agilent 16495E Half Size Blank Plate
Blank plate to use with half size connector plate to cover opening in shield box.



Agilent 16048D/E BNC Test Leads
Four-terminal test leads to connect Agilent 4284A Precision LCR Meter and E5250A. Length: 2 m (D) and 4 m (E).

E5250A Option 501 24 (8 x 3) Channel Multiplexer

E5250A Option 501 has three 8 channel shielded output connectors and 3 bias input ports on one card.

You can configure a total 96 outputs by using 4 cards.

Unique analog-bus and internal jumper connections allow flexible configurations.

For example, using four Option 501s, the Agilent E5250A can be configured as two 2 x 48 or four 2 x 24 or six 2 x 16 multiplexers. You can use an independent bias input port for each 8 channel output.

The following describe items to consider for complete setting of the system.

Instruments

The Agilent 4155C/4156C Semiconductor Parameter Analyzer is best suited for I-V measurement. The Agilent 4142B also can be used. For applying DC bias stress to many DUTs simultaneously, a DC power supply like Agilent 6627A is suitable. See example on page 9.

Switch Options

Select the number of Option 501s for E5250A considering maximum pin count that you need.

Environmental Chamber

For longtime reliability test of semiconductor devices, you may need to test the DUTs in a particular environment such as very low or high temperature/humidity. An environmental chamber is used for this purpose

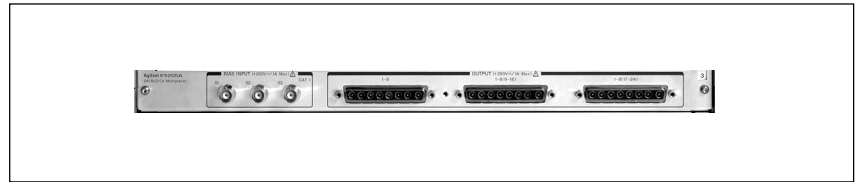

E5250A Option 501
24 (8 x 3) Channel Multiplexer

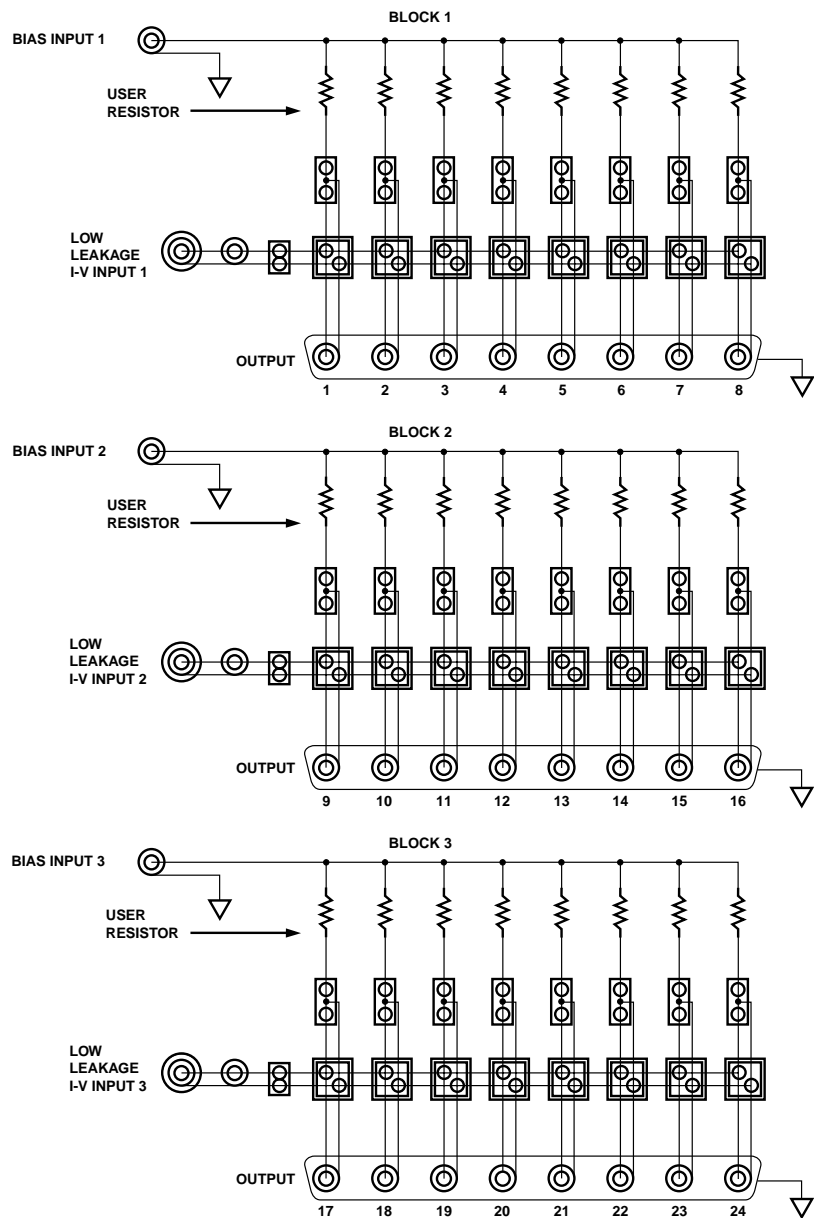

Figure 5. Option 501 block diagram.

when you test packaged devices. Vendors provide various types of chambers that are suitable for this purpose.

Cables between Instruments and the E5250A with Option 501

Select the triaxial or Kelvin triaxial cables for the Agilent E5250A input from the list on page 12. Also, the cables from DC power supply to E5250A Option 501 are recommended.

The cable from ground unit is not connected through the E5250A.

Cables to the Environmental Chamber

There are two methods to connect the cables to the environmental chamber.

One is direct connection using the Agilent 16494E wide temperature 8 channel shielded cable. Another is to use connector plates that are attached to the chamber, and use Agilent 16494D cable. See photos on page 12.

Interface to the DUT

You may need to design a DUT board to interface with DUT in the chamber. The board should be designed to keep low-leakage current for various environments if you require the best performance of the E5250A and instruments.

Typical Applications for E5250A Option 501 Multiplexer

One example of the use of Option 501 is a bias-temperature test of packaged devices.

Figure 6 shows the interconnection schematic for a 384 channel system. In this setup, you can apply various values of DC bias stress to many DUTs and obtain the degradation of device characteristics such as V_{th} , V_{dss} , or I_{gss} after long stress time.

This system realizes very high I-V measurement performance with chamber that you may not be able to achieve in a conventional reliability test system.

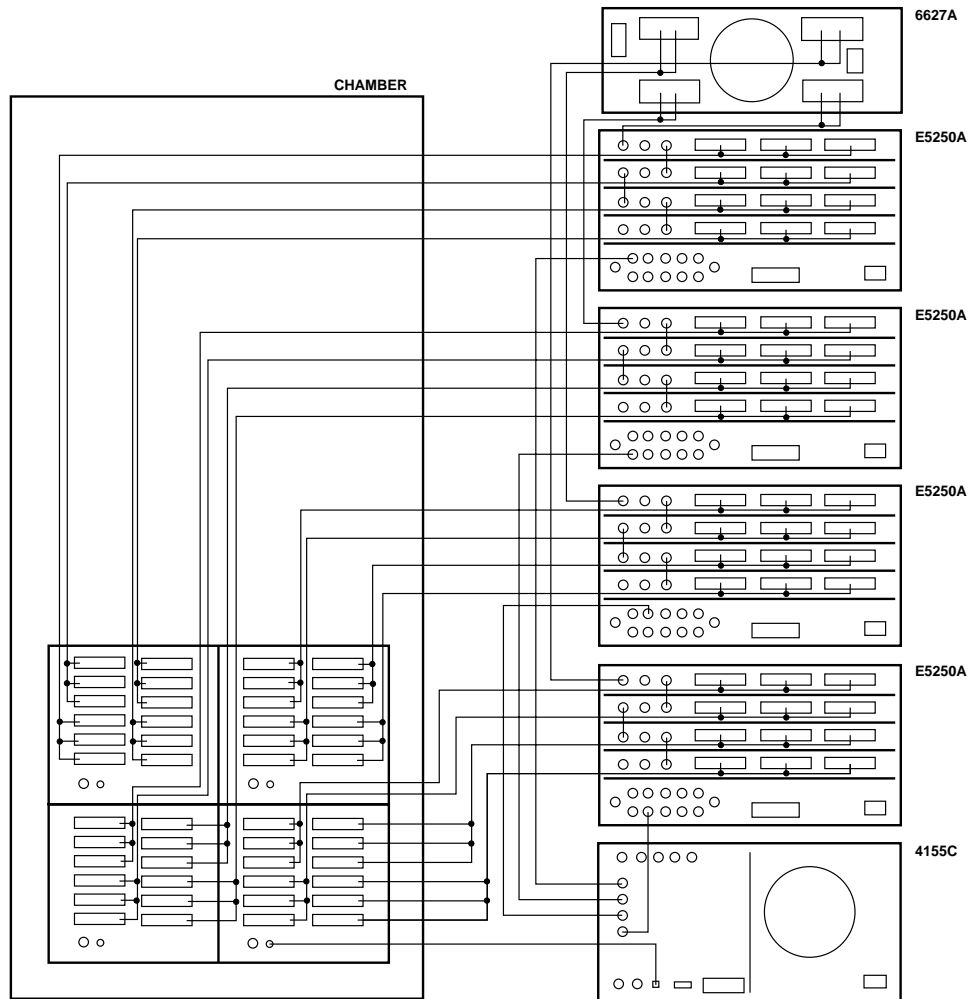

Figure 6. Typical application for Option 501.

Application 1: Hot Carrier Induced Degradation (HCI) of MOSFET Devices
 To evaluate HCI, use Option 501. In general, the total test time of HCI is very long. So, it is required to apply bias stress to many DUTs simultaneously, if you need mass of test data.

For the HCI measurement, the Agilent 4155C/4156C with Agilent E5250A has excellent accuracy so you can easily find small changes in the parameters.

Figure 7 shows a block diagram to configure the typical circuit for HCI measurement of 4 terminal MOSFETs.

The Agilent 6627A Multiple-Output System DC power supply provides stress voltage to all DUTs. The Agilent 4155C/4156C measures V_{th} , G_m , Source-Drain leakage current (I_{dss}), and monitors their degradation.

This example shows the unit configuration for an 8 FET measurement, which requires two 8 channel blocks of the multiplexer card. You may require more blocks if you need to connect other measurement ports to the DUTs drain and substrate.

The Agilent 6627A keeps substrate at a constant potential while forcing stress voltage to

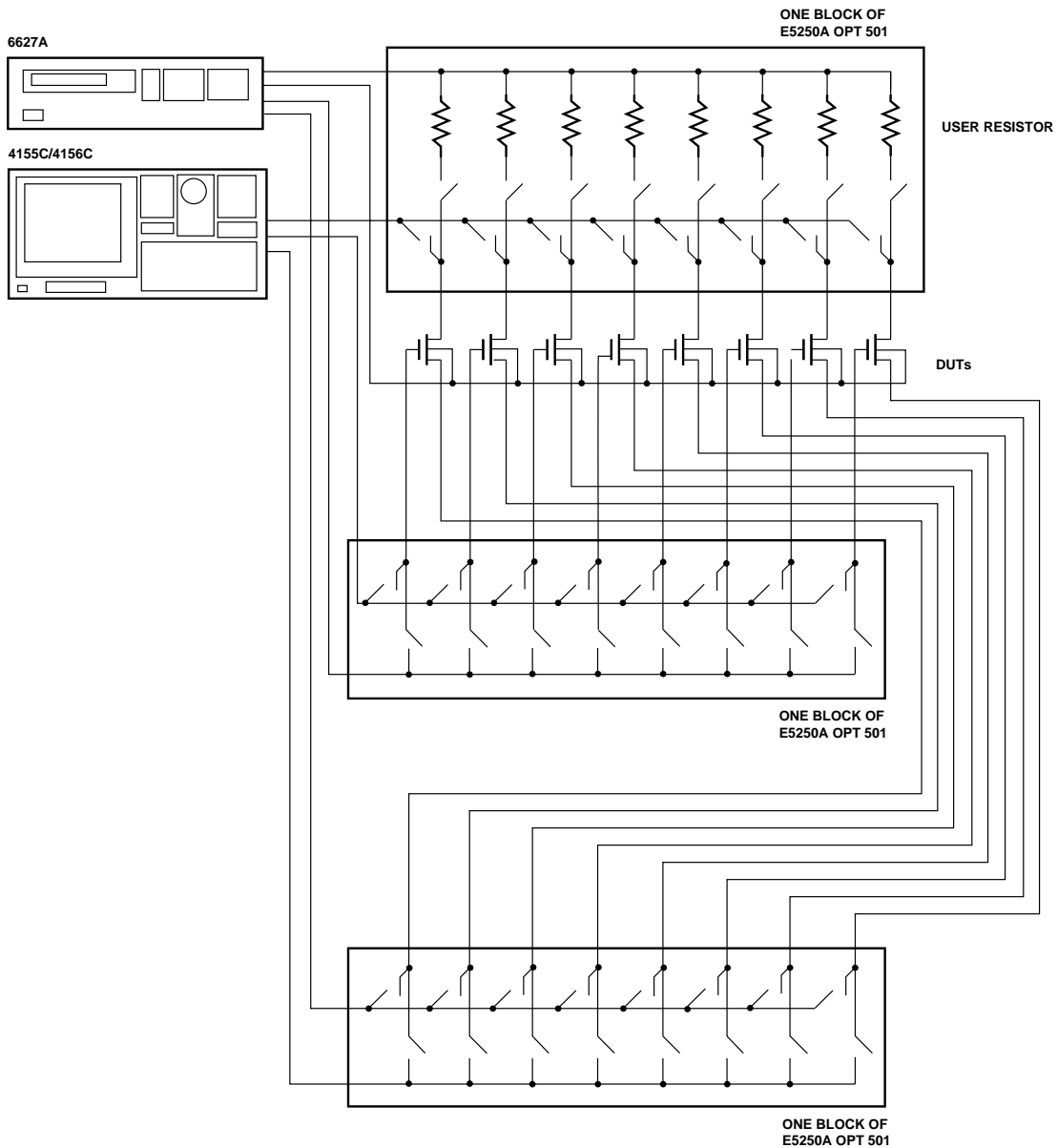

Figure 7. Block diagram of HCI measurement.

the gate and source. Then, the Agilent 4155C/4156C measures necessary parameters for HCI analysis.

You can expand this setup by number of DUT's to be tested.

Application 2: Time-Dependent Dielectric Breakdown (TDDB) of MOS Capacitor

To evaluate the TDDB test, use the Agilent E5250A Option 501.

For the TDDB test, the total test time is very long, and it is also required to apply voltage stress to many DUTs at the same time, until device breakdown occurs.

Figure 8 shows a block diagram to configure the typical circuit for TDDB test of 2 terminal MOS capacitors.

The Agilent 6627A Multiple-Output System DC power supply provides stress voltage to all DUTs.

This example shows a unit configuration for an 8 capacitor measurement, which requires one 8 channel block of the multiplexer card.

After applying the stress, disconnect the Agilent 6627A and connect 4155C/4156C, then measure leakage current of the capacitors one by one.

If capacitor is found to be broken, do not stress it again. Next, apply stress to all unbroken devices, and measure again. Continue this until all capacitors are broken.

Agilent E5250A and Agilent 4155C/4156C's low leakage measurement capability helps to find incipient degrading.

Agilent E5250A Option 501 has holders on which user can mount protective resistors. When the DUT breaks down, the resistance of the device becomes very low immediately.

User resistor limits the surge current and stabilizes the voltage stress.

You can expand this setup by number of DUTs to be tested.

There is one independent bias input port per 8 channel output, so you can apply different level of the voltage stress for more reliable data.

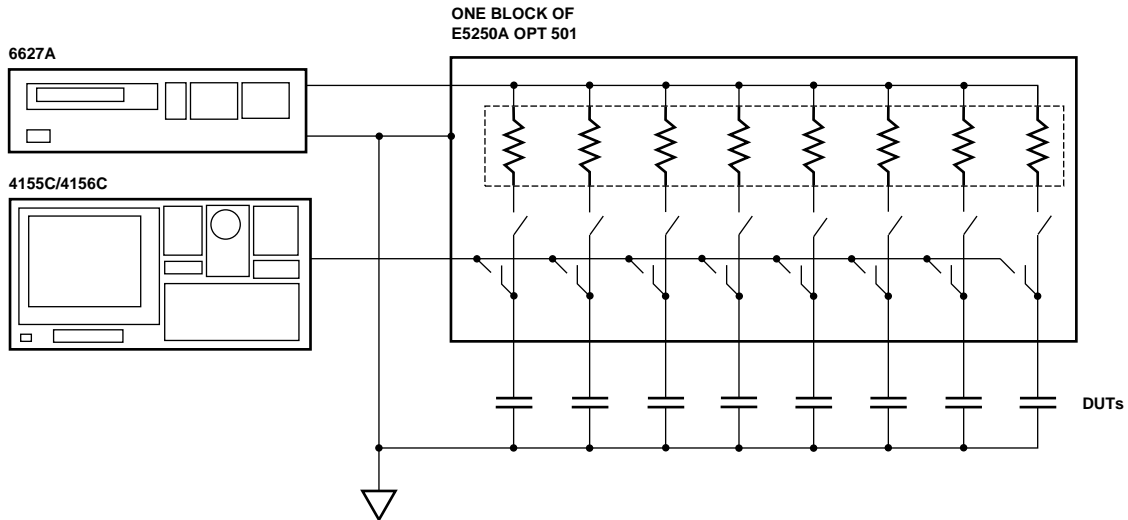

Figure 8. Block diagram of TDDB measurement.

Input/Output Cables and Connector Plates for Agilent E5250A Option 501



Agilent 16494D 8 Channel Shielded Coaxial Cable

Low noise shielded coaxial cable with 8 channel connectors for E5250A Option 501 on both ends. Length: 1.5 m and 3 m.



Agilent 16494E Wide Temperature 8 Channel Shielded Coaxial Cable

Low noise and wide temperature (-50 to +200°C) shielded coaxial cable with 8 channel connector for E5250A Option 501 on one end.

Bias Cable for the power supplies
For assembling one bias cable, following parts or equivalents are required. These are needed to interconnect the power supply's screw terminals and E5250As BNC bias ports.

Agilent 10501A
112 cm coaxial cable with BNC connector on one end.
Agilent 0890-1494 2 cm Tube
Agilent 0890-1351 2 cm Tube Ring Terminals



Agilent 16495C Connector Plate with Six 8 Channel Shielded Connector

Half size connector plate with six 8 channel shielded connectors, interlock and GNDU connector.



Agilent 16495D Connector Plate with Twelve 8 Channel Shielded Connector

Full size connector plate with twelve 8 channel shielded connectors, interlock and GNDU connector.



Agilent 16495E Half Size Blank Plate

Blank plates to use with half size connector plates for filling unnecessary hole on chamber.

Other Utility Parts

Agilent E5255-61626

A 2 m cable with coaxial connector on one end for fitting into the connector on Agilent 16495C/D Connector Plate. Eliminates need to solder each cable.

Use Agilent 1251-2170 tool to remove original connector and replace with this connector.

Agilent 1251-00179

Original contractor on the shielded connectors of Agilent 16495C/D connector plate.

Agilent 1251-2170

Remover tool for exchanging the connectors.

Ordering Information

| | | |
|--------------------------|---|-----------------|
| <input type="checkbox"/> | Switch Mainframe and Cards | Quantity |
| | Agilent E5250A Low Leakage Switch Mainframe | _____ *1) |
| | 001 10 x 12 Matrix Switch (E5252A) | _____ |
| | 301 Relay Function Test Adapter | _____ *2) |
| | 501 24 Channel Multiplexer (E5255A) | _____ |

Note 1: The mainframe does not furnish any cables.

Note 2: Please select this option if it is your first purchase of Agilent E5250A.

| | | |
|--------------------------|---|-----------------|
| <input type="checkbox"/> | Cables (See page 7 and 12 for photo and detailed explanations) | Quantity |
| | Agilent 16494A Triaxial Cable | _____ *3) |
| | 001 Triaxial Cable (1.5 m) | _____ |
| | 002 Triaxial Cable (3 m) | _____ |
| | 003 Triaxial Cable (80 cm) | _____ |
| | Agilent 16494B Kelvin Triaxial Cable | _____ *3) |
| | 001 Kelvin Triaxial Cable (1.5 m) | _____ |
| | 002 Kelvin Triaxial Cable (3 m) | _____ |
| | 003 Kelvin Triaxial Cable (80 cm) | _____ |
| | Agilent 16494C Kelvin Triaxial Cable for 4142 | _____ *3) |
| | 001 Kelvin Triaxial Cable for 4142 (1.5 m) | _____ |
| | 002 Kelvin Triaxial Cable for 4142 (3 m) | _____ |
| | Agilent 16494D 8 Channel Shielded Coaxial Cable | _____ *3) |
| | 001 8 Channel Shielded Coaxial Cable (1.5 m) | _____ |
| | 002 8 Channel Shielded Coaxial Cable (3 m) | _____ |
| | Agilent 16494E Wide Temperature 8 Channel Shielded Coaxial Cable | _____ *3) |
| | 001 Wide Temperature 8 Channel Shielded Coaxial Cable (3 m) | _____ |

Note 3: Fill in total number of all cable length options for the model.

| | | |
|--------------------------|---|-----------------|
| <input type="checkbox"/> | Connector Plates (See page 7 and 12 for photo and detailed explanations) | Quantity |
| | Agilent 16495A Connector Plate with 12 Triaxial Interlock/GNDU | _____ |
| | Agilent 16495B Connector Plate with 24 Triaxial Interlock/GNDU | _____ |
| | Agilent 16495C Connector Plate with Six 8 Channel SHLD Connectors | _____ |
| | Agilent 16495D Connector Plate with Twelve 8 Channel SHLD Connectors | _____ |
| | Agilent 16495E Half Size Blank Plate | _____ |

| | | |
|--------------------------|---|-----------------|
| <input type="checkbox"/> | Channel Upgrade Products for Agilent E5250A Mainframe User | Quantity |
| | Agilent E5252A 10 x 12 Matrix Switch (For Agilent E5250A Option 001 Equivalent) | _____ *4) |
| | Agilent E5255A 24 (8 x 3) Channel Multiplexer (For Agilent E5250A Option 501 Equivalent) | _____ *4) |

Note 4: The cards will be shipped ready to install. But, if you need the performance verification test to guarantee the switch specifications after installing the cards, please contact the nearest Agilent service office.

Ordering Information

Software Guide for Agilent E5250A

Interactive Characterization Software on Windows 3.1 Environment

| | | Quantity |
|----------------|---------------------------------------|----------|
| Agilent E5230B | Interactive Characterization Software | _____ |
| Agilent E5231B | IV Parametric Driver Library | _____ |
| Agilent E5232B | CV Driver Library | _____ |
| Agilent E5233B | Switch Driver Library | _____ |

CV driver library includes driver for Agilent 4284A Precision LCR Meter with Capacitance compensation routine through Agilent E5250A Option 001 and Cables.

For detailed descriptions, please see the Agilent E5230B Technical Data (Agilent P/N 5964-2377E).

Furnished Programs and Routines with Agilent E5250A Mainframe

Utility Programs (Agilent Instrument BASIC, runs on Agilent 4155C/4156C)

| | |
|------------------------------------|---|
| Virtual Front Panel (VFP) Program: | Allows Front Panel Like Operation of E5250A. |
| Selftest Program: | Performs the Selftest with Agilent E5250A Option 301. |

Sample Program and Routines (Agilent BASIC, for E5250A and the Instruments)

C-Compensation Routine (Used with Agilent 4284A)

VFP Data Upload Library: Routines to Upload Setup Data Stored by VFP.

Sample Application for Matrix Switch: Vth and Capacitance Measurement.

Sample Application for Multiplexer: Hot Carrier Induced Degradation Measurement.

Cable Compatibility Guide for E5250A Input and Output

| Agilent Model | Descriptions | For Input Use | For Output Use |
|----------------|--|-------------------------|-------------------|
| Agilent 16494A | Triaxial Cable ⁽¹⁾ | Yes (for Non-Kelvin) | Yes (for #001) |
| Agilent 16494B | Kelvin Triaxial Cable ⁽¹⁾ | Yes (for Agilent 4156C) | Yes (for #001) |
| Agilent 16494C | Kelvin Triaxial Cable for 4142 | Yes (for Agilent 4142B) | Yes (for #001) |
| Agilent 16494D | 8 Channel Shielded Coaxial Cable | No | Yes (for #501) |
| Agilent 16494E | Wide Temperature 8 Channel Shielded Coaxial Cable | No | Yes (for #501) |
| Agilent 16493C | Triaxial Cable for 41420B/41421B (or Agilent 4155C Furnished Triaxial Cables) | Yes (Non-Kelvin) | Yes (for #001) |
| Agilent 16493D | Quad Axial Cable for 41420B/41421B | No ⁽²⁾ | No ⁽²⁾ |
| Agilent 16493H | Ground Unit Cable | No ⁽³⁾ | No ⁽³⁾ |
| Agilent 16493J | Interlock Cable for 4155C/4156C | No ⁽³⁾ | No ⁽³⁾ |
| Agilent 16493K | Kelvin Triaxial Cable for 4156C (Or Agilent 4156C Furnished Kelvin Triaxial Cables) | No ⁽⁴⁾ | No ⁽⁴⁾ |

Note 1: The 80 cm length cable (Option 003) is not suitable for output use.

Note 2: Please order Agilent 16494C instead of 16493D.

Note 3: Connect directly to Connector Plate, not through E5250A Switch Cards.

Note 4: Please order Agilent 16494B instead of 16493K.

Ordering Information

□ Configuration Examples

Example 1. 48 Channel Matrix Switch Configuration for General Parametric Measurement

These examples are based on the figure on page 5, excludes system controller, software, and probe.

| | | |
|-------------------|--|----------|
| Agilent E5250A | (*1) Low Leakage Switch Mainframe | 1 |
| | 001 10 x 12 Matrix Switch (E5252A) | 4 |
| | 301 Relax Function Test Adapter | 1 |
| Agilent 16494A | Triaxial Cable | 52 |
| | 002 Triaxial Cable (3 m) | 48 |
| | 003 Triaxial Cable (80 cm) | 4 |
| Agilent 16495B | Connector Plate with 24 Triaxial Interlock/GNDU | 2 |
| Agilent 4155C | (*1) Semiconductor Parameter Analyzer | 1 |
| Agilent 4284A | (*1) Precision LCR Meter | 1 |
| | 001 Power Amplifier/DC Bias | 1 |
| | 006 2 m/4 m Cable Length Option | 1 |
| Agilent 10833A | Agilent-IB Cable | 2 |
| Agilent 16048D | BNC Test Cable (2 m) | 1 |
| Agilent 1250-2405 | BNC T-Connector | 2 |
| Agilent 8120-4461 | Coaxial Cable between Connector Plate and Probe Card | 2 m x 48 |

Example 2. 384 Channel Multiplexer Configuration for Long Term Reliability Test.

These examples are based on Figure 6 on page 8, excludes system controller, software, temperature chamber, and DUT boards in the chamber.

| | | |
|---|---|-----|
| Agilent E5250A | Low Leakage Switch Mainframe | 4 |
| | 301 Relax Function Test Adapter | 1 |
| | 501 24 Channel Multiplexer (E5255A) | 16 |
| Agilent 16494D | 8 Channel Shielded Coaxial Cable | 48 |
| | 002 8 Channel Shielded Coaxial Cable (3 m) | 48 |
| Agilent 16495D | Connector Plate with Twelve 8 Channel SHLD Connectors | 4 |
| Agilent 4155C | (*1) Semiconductor Parameter Analyzer | 1 |
| Agilent 10833A | Agilent-IB Cable | 5 |
| Agilent 6627A | (*1) Multiple-Output System DC Power Supply | 1 |
| For Connection to DC Power Supply and Multiplexer | | |
| Agilent 10501A | 112 cm Coaxial Cable with BNC Connector on One End | 4 |
| Agilent 0890-1494 | 2 cm Tube (For Protecting Bare Cable) | 4 |
| Agilent 0890-1351 | 2 cm Tube (For Protecting Bare Cable) | 4 |
| Agilent 8120-1838 | Cable between Bias Ports of E5250A #501 (BNC-BNC) | 12 |
| Agilent E5255-61626 | Assembled Coaxial Cable to DUT Board | 384 |
| Agilent 1251-2170 | Remover Tool for Exchanging the Connector | 1 |
| For Rack Mount | | |
| Agilent E3662A (*1) | 19 inch Rack | 1 |
| Agilent E3663A | Rail Kit | 5 |
| Agilent 5062-3985 | Rack Mount Kit | 5 |
| Agilent 5062-3977 | 5 1/4 Filler Kit | 1 |

Note 1: Select appropriate options for power line and localization.

Please contact local Agilent sales office for more details.

Appendix

How to Select Options for Cable Length

The Agilent 4155C/4156C or Agilent 4142B have low current forcing and measurement capability by their SMU (Source Monitor Unit) technology. The SMU uses a kind of feedback circuit for maintaining very high stability of the current/voltage sourcing. Therefore, the guard capacitance (a load for SMUs) of connections to SMU must be within certain limits to prevent SMU circuit oscillation.

The limit is about 900 pF in the Agilent 4155C/4156C or the Agilent 4142B's case, for example.

You should select proper cable lengths to keep small guard capacitance for the SMUs. A system using E5250A sometimes needs longer cable lengths than for the standalone instruments.

If you plan to connect more than 6 m (E5250A Option 001) or 4 m (E5250A Option 501) total cable length (both instrument to switch and switch to the DUTs), make sure the cable guard capacitance does not exceed 900 pF.

Table 1, on page 16, shows the guard capacitance for each cable and the E5250A.

How to Mount the Connector Plates

The Agilent 16495A/B connector plate mounts on the side panel of your probe shield box and is for connecting triaxial output cable from matrix switch. The other side of the plate is for connecting coaxial cable to probe as shown in Figure 9. Figure 9 shows how to mount the connector plate. If you use a low leakage probing system that has a built-in shield box, you may not need to install the connector plate and cables.

See page 17 and 18 for detailed dimensions of the connector plates.

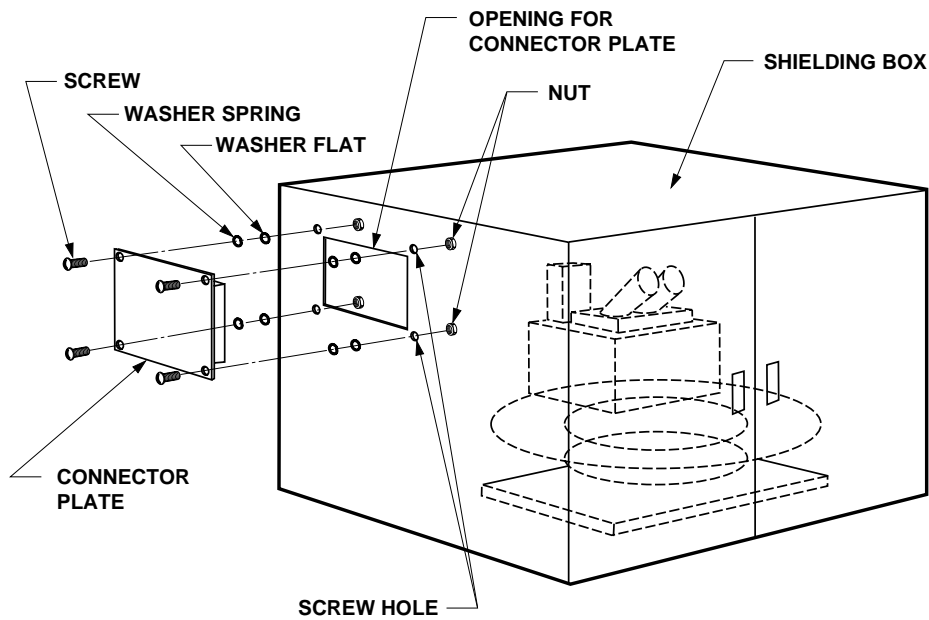

Figure 9. Mounting connector plates.

Table 1. Typical Value of Guard Capacitance.

| Models | Cable Length | Guard Capacitance |
|---|---------------------|--------------------------|
| E5250A with Option 001 | | |
| Guard Capacitance between an I-V Port and an Output Terminal | Not Applicable | 145 pF |
| Additional Guard Capacitance when Another 001 Card is Added | Not Applicable | 8 pF |
| E5250A with Option 501 | | |
| Guard Capacitance between an I-V Port and an Output Terminal | Not Applicable | 180 pF |
| Additional Guard Capacitance when Another 501 Card is Added | Not Applicable | 60 pF |
| 16494A Triaxial Cable | | |
| Option 001 | 1.5 m | 125 pF |
| Option 002 | 3.0 m | 240 pF |
| Option 003 | 80 cm | 75 pF |
| 16494B Kelvin Triaxial Cable | | |
| Option 001 | 1.5 m | 140 pF |
| Option 002 | 3.0 m | 260 pF |
| Option 003 | 80 cm | 90 pF |
| 16494C Kelvin Triaxial Cable for 4142 | | |
| Option 001 | 1.5 m | 140 pF |
| Option 002 | 3.0 m | 260 pF |
| 16494D 8 Channel Shielded Coaxial Cable | | |
| Option 001 | 1.5 m | 125 pF |
| Option 001 | 3.0 m | 240 pF |
| 16494E Wide Temperature 8 Channel Shielded Coaxial Cable | | |
| Option 001 | 3.0 m | 240 pF |
| Agilent P/N 8120-4461 Coaxial Cable | | |
| For Connection to DUT | Determined by User | 130 pF/m |

Guard Capacitance:

The structure of triaxial has three conductors: signal (sense/force), guard and ground. The guard capacitance is capacitance between the signal and guard.

Example:

| | | |
|-----------------------------|------------------------------------|--|
| Switch: | E5250A Option 001 x 4 (48 Channel) | 145 pF + 8 pF x 3 |
| Cables: | 16494A #001 | 125 pF |
| | 16494A #003 | 75 pF |
| | 8120-4461 2 m | 130 pF x 2 |
| Probe Card: | | < 10 pF (in usual case) |
| Total Guard Capacitance is: | | |
| | | 145 pF + 24 pF + 125 pF + 75 pF + 260 pF + 10 pF = 639 pF < 900 pF |

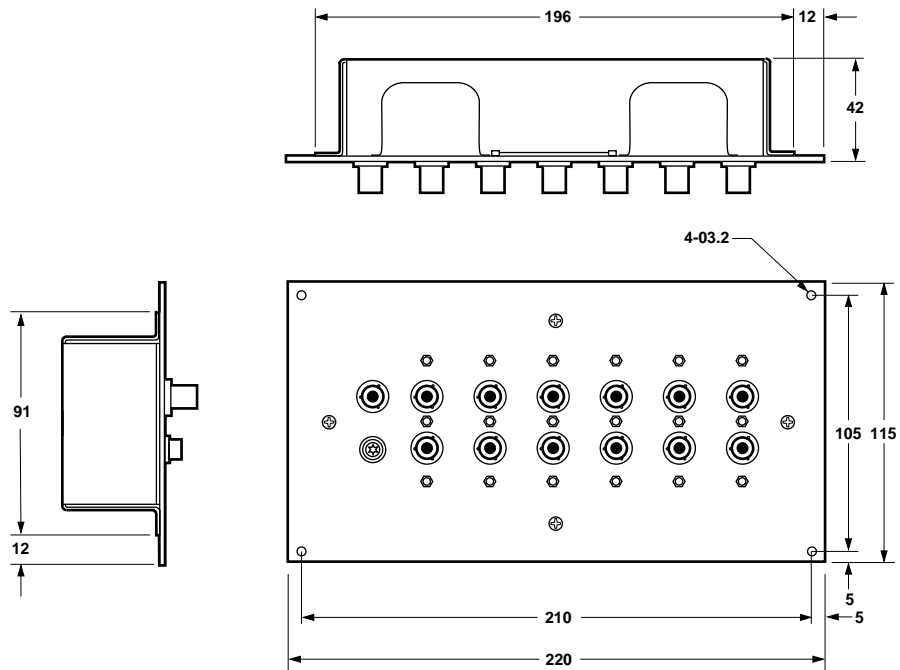

Figure 10. Agilent 16495A connector plate.

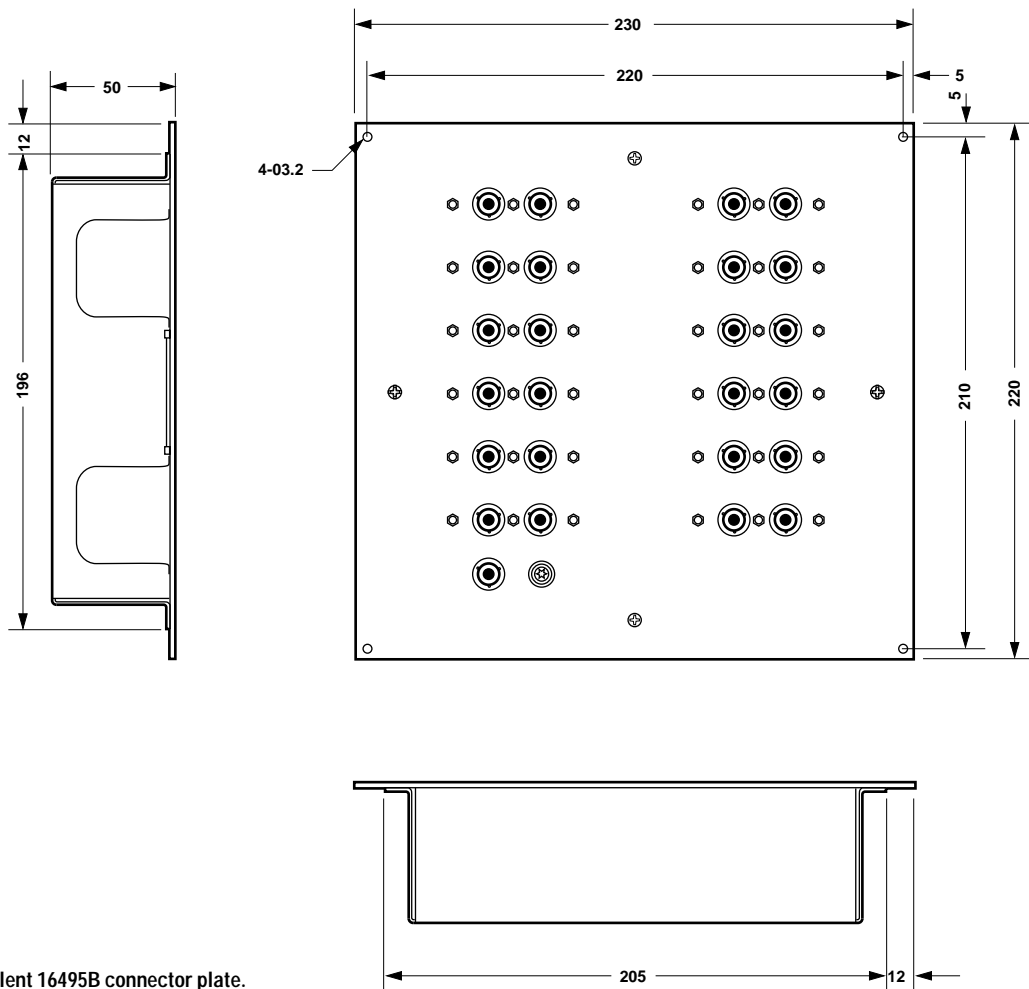

Figure 11. Agilent 16495B connector plate.

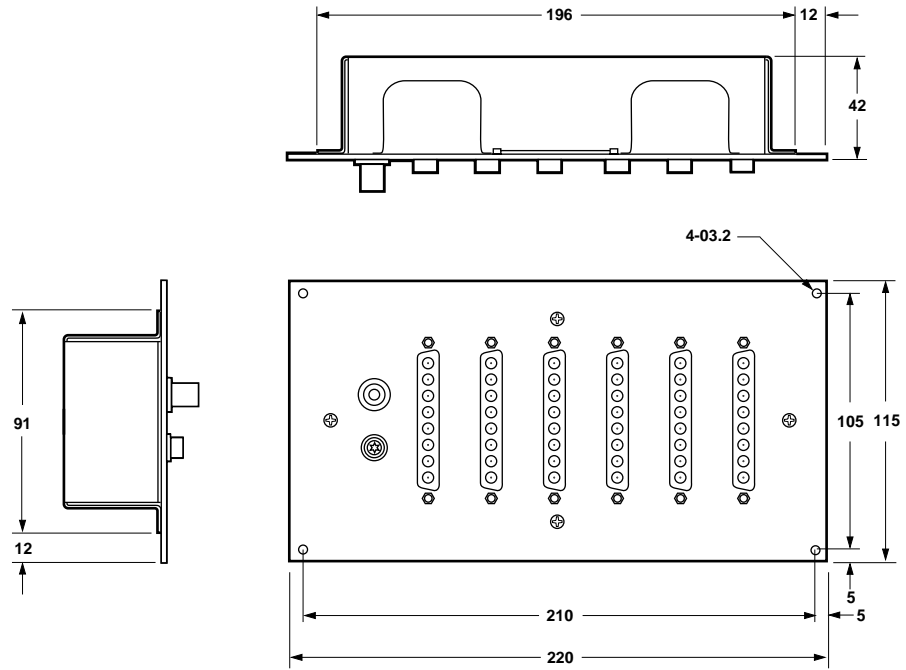

Figure 12. Agilent 16495C connector plate.

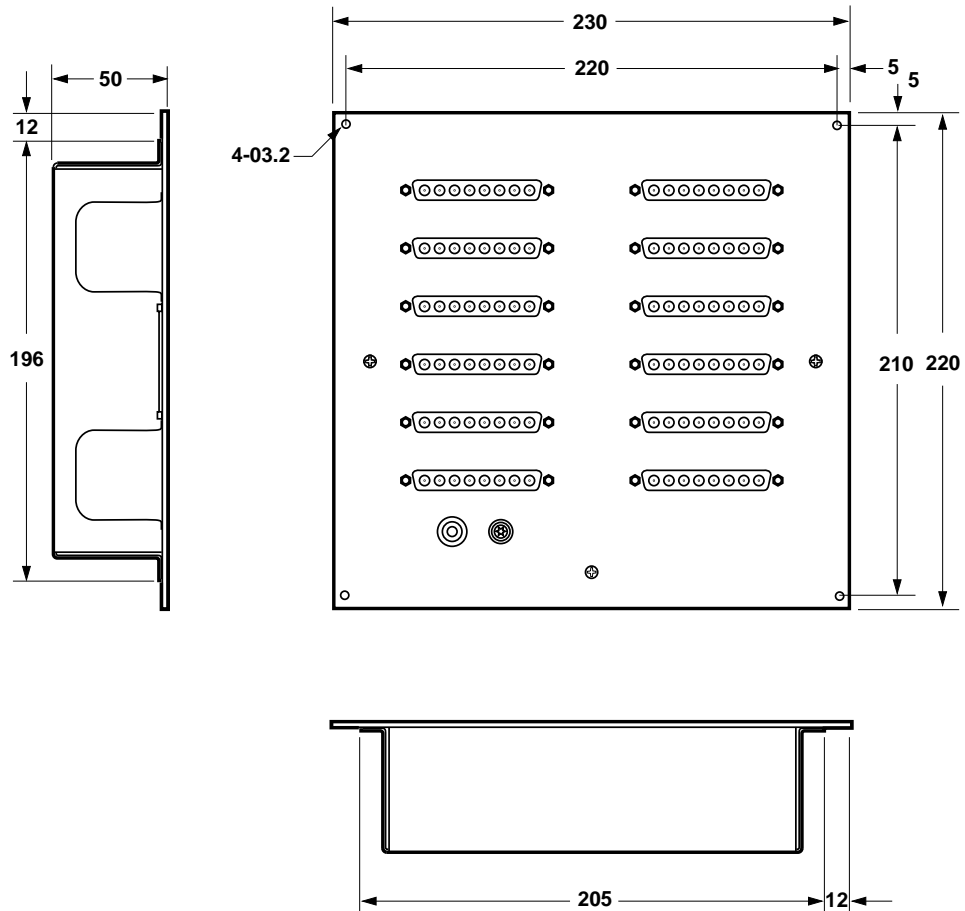

Figure 13. Agilent 16495D connector plate.

Note: Information relating to the Agilent 4155C/4156C is also applicable to the Agilent 4155A/4156A and 4155B/4156B, except for the front-panel matrix control.

For more information about Agilent Technologies semiconductor test products, applications and services, visit our website:

www.agilent.com/go/semiconductor

For information about other Agilent test and measurement products, go to www.agilent.com/find/tmdir.

United States:

Agilent Technologies
1 800 452 4844

Agilent Technologies Canada Inc.
1 877 894 4414

Europe:

Agilent Technologies
(3120) 547 2000

Japan:

Agilent Technologies Japan Ltd.
(81) 426 56 7832
Fax: (81) 426 56 7840

Latin America:

Agilent Technologies
(305) 269 7500
Fax: (305) 269 7599

Australia/New Zealand:

Agilent Technologies Australia Pty. Ltd.
1-800 G29 485 (Australia)
Fax: (613) 9272 0849
0 800 738 378 (New Zealand)
Fax: (644) 495 8950

Asia Pacific:

(852) 2599 7889
Fax: (852) 2506 9233

Taiwan:

Agilent Technologies
(886-2) 717-9524
Fax: (886) 2 718 9860

Korea:

(822) 769-0800
Fax: (822) 786-1083

Singapore:

(65) 1800-292 8100
Fax: (65) 275 0387

Technical data subject to change without notice.

© Copyright 2000 Agilent Technologies, Inc.

Printed in USA 11/00

5964-4091E



Agilent Technologies

Innovating the HP Way