

# **Sample Application Programs Guide Book**

Agilent 4155B Semiconductor Parameter Analyzer  
Agilent 4156B Precision Semiconductor Parameter Analyzer



**Agilent Technologies**

**Agilent Part No. 04156-90700**

**Printed in Japan January 2000**

**Edition 3**

---

## Legal Notice

The information contained in this document is subject to change without notice.

Copyright © 1997, 1998 Agilent Technologies

This document contains information which is protected by copyright. All rights are reserved. Reproduction, adaptation, or translation without prior written permission is prohibited, except as allowed under the copyright laws.

- **Product Warranty**

Agilent Technologies warrant Agilent Technologies hardware, accessories and supplies against defects in materials and workmanship for the period of one year from the warranty start date specified below. If Agilent Technologies receive notice of such defects during the warranty period, Agilent Technologies will, at its option, either repair or replace products which prove to be defective. Replacement products may be either new or like-new.

Warranty service of this product will be performed at Agilent Technologies. Buyer shall prepay shipping charges to Agilent Technologies and Agilent Technologies shall pay shipping charges to return the product to Buyer. However, Buyer shall pay all shipping charges, duties, and taxes for products returned to Agilent Technologies from another country.

Agilent Technologies do not warrant that the operation of Agilent Technologies products will be uninterrupted or error free. If Agilent is unable, within a reasonable time, to repair or replace any product to a condition as warranted, customer will be entitled to a refund of the purchase price upon prompt return of the product.

The Agilent Technologies products may contain remanufactured parts equivalent to new in performance or may have been subject to incidental use.

The warranty period begins on the date of delivery or on the date of installation if installed by Agilent Technologies. If customer schedules or delays Agilent Technologies installation more than 30 days after delivery, warranty begins on the 31st day from delivery.

Warranty does not apply to defects resulting from (a) improper or inadequate maintenance or calibration, (b) software, interfacing, parts or supplies not supplied by Agilent Technologies, (c) unauthorized modification or misuse, (d) operation outside of the published environmental specifications for the product, or (e) improper site preparation or maintenance.

To the extent allowed by local law, the above warranties are exclusive and no other warranty or condition, whether written or oral, is expressed or implied and Agilent Technologies specifically disclaim any implied warranties or conditions of merchantability, satisfactory quality, and fitness for a particular purpose.

Agilent Technologies will be liable for damage to tangible property per incident up to the greater of \$300,000 or the actual amount paid for the product that is the subject of the claim, and for damages for bodily injury or death, to the extent that all such damages are determined by a court of competent jurisdiction to have been directly caused by a defective Agilent Technologies product.

To the extent allowed by local law, the remedies in this warranty statement are customer's sole and exclusive remedies. Except as indicated above, in no event will Agilent Technologies or its suppliers be liable for loss of data or for direct, special, incidental, consequential (including lost profit or data), or other damage, whether based in contract, tort, or otherwise.

For consumer transactions in Australia and New Zealand: the warranty terms contained in this statement, except to the extent lawfully permitted, do not exclude, restrict or modify and are in addition to the mandatory statutory rights applicable to the sale of this product to you.

- Assistance

Product maintenance agreements and other customer assistance agreements are available for Agilent Technologies products.

For any assistance, contact your nearest Agilent Technologies Sales Office.

- Certification

Agilent Technologies Inc. certifies that this product met its published specifications at the time of shipment from the factory. Agilent further certifies that its calibration measurements are traceable to the National Institute of Standards and Technology (NIST), to the extent allowed by the Institute's calibration facility, and to the calibration facilities of other International Standards Organization members.

---

## Printing History

<b>Edition 1:</b>	August 1997
<b>Edition 2:</b>	November 1998
<b>Edition 3:</b>	January 2000

---

## In This Manual

This manual describes some sample application programs and setup files, which will be helpful for creating your own applications using Agilent 4155B/4156B.

All programs and setup files described in this manual are stored on the Sample Application Program Disk (DOS formatted, 3.5-inch diskette) that is furnished with your 4155B/4156B. All programs are written in the Instrument BASIC, and ready to run in the 4155B/4156B's built-in Instrument BASIC environment.

This manual covers the following applications:

- V-RAMP
- J-RAMP
- SWEAT
- GO/NO-GO Test
- HCI Degradation Test
- Charge Pumping
- Flash EEPROM Test
- TDDB
- Electromigration

---

### CAUTION

These programs are only examples, so you may need to modify these programs and setup files for your own application before executing. If these example programs damage your devices, Agilent Technologies is *NOT LIABLE* for the damage.

---

### NOTE

You should copy all files in the Sample Application Program Disk to a diskette that you will use as your working diskette, and keep the original diskette as backup.

---

---

# Contents

## 1. V-RAMP

Theory of V-Ramp Test Procedure .....	1-3
V-Ramp Test Overview .....	1-3
Initial Test .....	1-4
Post Stress Test .....	1-4
Ramp Stress Test .....	1-5
Failure Categorization and Data Recording .....	1-7
Basic Operation .....	1-8
Methodology .....	1-8
Required Equipment .....	1-16
Files on the Diskette .....	1-16
Executing the VRAMP Program .....	1-17
Flowchart of Sample VRAMP Program .....	1-18
Customization .....	1-20
Using an External Computer .....	1-20
Specifying Setup File to Load .....	1-21
File for Saving Measurement Results .....	1-21
Setting up Input Parameters .....	1-22
Searching for 10 $\mu$ Iexpect .....	1-23
Measurement Setups .....	1-24
Setups for Initial and Post Stress Tests .....	1-24
Setups for Ramped Stress Test .....	1-24

## 2. J-RAMP

Theory of J-Ramp Test Procedure .....	2-3
J-Ramp Test Overview .....	2-3
Initial Test .....	2-4
J-Ramp Stress Test .....	2-5
Post Stress Test .....	2-7
Failure Categorization and Data Recording .....	2-8
Basic Operation .....	2-9
Methodology .....	2-9
Required Equipment .....	2-20
Program Files Required .....	2-20
Executing the JRAMP Program .....	2-20
Flowchart of Sample JRAMP Program .....	2-22
Customization .....	2-24
Using an External Computer .....	2-24
Specifying Setup File to Load .....	2-25

---

## Contents

File for Saving Measurement Results .....	2-25
Setting up Input Parameters .....	2-26
When SMU Lacks Power to Break Oxide .....	2-27
Measurement Setups .....	2-28
Setups for Initial and Post Stress Tests .....	2-28
Setups for Ramped Stress Test .....	2-28
Proof of Equations .....	2-36
Step Increase Factor ( <i>F</i> ) .....	2-36
Step Time ( <i>Step_time</i> ) .....	2-36
Current Stop Value ( <i>Istop</i> ) .....	2-36
<b>3. SWEAT</b>	
SWEAT .....	3-3
Overview .....	3-3
Input Parameters .....	3-4
Initial Resistance (Rinit) Measurement .....	3-5
CTTF .....	3-5
Rfail .....	3-5
Exit Condition .....	3-5
Output Parameters .....	3-6
Basic Operation .....	3-7
Methodology .....	3-7
Required Equipment .....	3-10
Files on the Diskette .....	3-10
Execution .....	3-11
Sample SWEAT Program Overview .....	3-12
Customization .....	3-13
Using External Computer or Built-in Controller .....	3-13
Specifying Setup File to Load .....	3-13
File for Saving Measurement Results .....	3-14
Setting up Input Parameters .....	3-15
Setting up Input Parameters Related to CTTF Calculation .....	3-15
How to Reduce the Settling Time of CTTF .....	3-16
Defining JSTART .....	3-18
Current Adjustment Routine .....	3-18
Setup files .....	3-19
Setup File for Initial Resistance Measurement .....	3-19
Setup File for Stress/Resistance Measurement .....	3-19

---

## Contents

### 4. Go/NO-GO

GONOGO Sample Program .....	4-3
Basic Operation .....	4-5
Required Equipment .....	4-5
Files on the Diskette .....	4-5
Sample Devices .....	4-6
Connection .....	4-6
Execution .....	4-7
Viewing All Curves while Measurement is in Progress .....	4-10
Viewing Only Results while Measurement is in Progress .....	4-11
Viewing a Particular Measurement Curve .....	4-12
Changing Limits .....	4-13
Displaying Statistical Data .....	4-13
Exporting Data to Spreadsheet .....	4-14
Customization .....	4-15
Overview .....	4-15
Hints to Use with Handler .....	4-21

### 5. HCI Degradation Test

Hot-Carrier-Induced (HCI) Degradation Test .....	5-3
Overview .....	5-3
Determining Stress Bias Conditions .....	5-4
Selecting Test Devices .....	5-4
Initial Characterization .....	5-4
Parameter Definitions .....	5-5
Stress Cycle .....	5-6
Interim Characterization .....	5-6
Stress Termination .....	5-6
Precautions .....	5-6
Technical Requirements .....	5-7
HCI Degradation Test Data Analysis .....	5-8
Basic Operation .....	5-11
Methodology .....	5-11
Input Parameters .....	5-11
HCI Degradation Test .....	5-15
HCI Degradation Data Analysis .....	5-16
Required Equipment .....	5-17
Files on the Diskette .....	5-18
Execution .....	5-19
Sample HCI Degradation Test Program (DCDAHC) Overview .....	5-27

---

## Contents

Sample HCI Degradation Test Data Analysis Program (ANALYSIS) Overview	5-30
Customization	5-32
Using External Computer or Built-in Controller	5-32
Modifying and Specifying Setup File to Load	5-33
Changing File for Saving Measurement Results	5-34
Changing Input Parameters for HCI Degradation Test	5-35
To Change Pin Assignment	5-37
To Change Number of Test Devices	5-37
Changing the Cumulative Stress Times	5-38
Skipping Determination of Gate Stress Bias Condition	5-38
Reducing the Interval between Stress and Interim Measurement	5-39
Selecting Parameter Shift Graphs to Draw	5-39
If You Don't Use Switching Matrix	5-40
Using Another Switching Matrix	5-40
Performing HCI Degradation Test with AC Stress	5-41
Performing Reverse Mode Test	5-42
Changing Input Parameters for Test Data Analysis	5-43
Not to Pause Program after each Tdc Extraction	5-43
Changing File Name to save Calculated Average Tdc	5-43
Setup Files	5-44
Setup File for Id-Vd Measurement to Determine Drain Stress Voltage	5-44
Setup File for Ib-Vg Measurement to Determine Gate Stress Voltage	5-46
Setup File for Gate Leakage Current Measurement	5-49
Setup File for Initial/Interim Characterization	5-52
Setup File for DC Stress	5-55
Setup File for AC Stress	5-56
<b>6. Charge Pumping</b>	
Charge Pumping Methods	6-3
Square Pulse Method	6-3
Triangular Pulse Method	6-3
Trapezoidal Pulse Method	6-3
Equipment Required	6-4
Square Pulse Method	6-5
To Extract Interface-state Density	6-5
Program Files Required	6-7
Sample Setup File	6-7
To Execute the Sample Program	6-10
Square Pulse Method without Program	6-13
Requirement	6-13

---

## Contents

Sample Setup File .....	6-13
To Execute the Measurement .....	6-16
Triangular Pulse Method .....	6-17
To Extract Interface-state Density .....	6-18
To Extract Capture Cross Section .....	6-19
Program Files Required .....	6-20
Sample Setup File .....	6-20
To Execute the Sample Program .....	6-24
Trapezoidal Pulse Method .....	6-27
To Extract Interface-state Density .....	6-28
Program Files Required .....	6-30
Sample Setup File .....	6-30
To Execute the Sample Program .....	6-33
Program Modification Examples .....	6-36
To Change the Initial Value of Input Parameters .....	6-36
To Change the Measurement Unit .....	6-42
To Change the Destination of the File Operation .....	6-45
<b>7. Flash EEPROM Test</b>	
Program Overview .....	7-3
Device Connection for NOR type flash EEPROM .....	7-3
Device Connection for NAND type flash EEPROM .....	7-4
Main Program .....	7-5
Stress_loop .....	7-7
Vth_meas .....	7-8
Program Customization .....	7-9
Subprogram “Test_setting” .....	7-9
Measurement setup file for Vth measurement (for NOR type) .....	7-10
Stress setup file for write pulse of NOR type .....	7-11
Stress setup file for erase pulse of NOR type .....	7-11
Stress setup file for write pulse of NAND type .....	7-12
Stress setup file for erase pulse of NAND type .....	7-12
Program Listing .....	7-13
<b>8. Time Dependent Dielectric Breakdown (TDDB)</b>	
Application Overview .....	8-3
Customization .....	8-4

---

## Contents

### 9. Electromigration

Application Overview .....	9-3
Customization .....	9-4



**1**

**V-RAMP**



Voltage-Ramped (V-Ramp) test is one of the Wafer Level Reliability (WLR) tests, which is used to evaluate device reliability on a wafer. This test can provide quick evaluation data for estimating the overall reliability of thin oxides, and this data can be used to improve the thin oxide manufacturing process.

With the thickness of oxide shrinking along with device geometries, creating a reliable thin oxide has become an important issue. The integrity of the thin oxide in a MOS device is a dominant factor in determining the overall reliability of a micro-circuit. The V-Ramp test can promptly give useful feedback to the manufacturing process about oxide reliability.

This operation manual covers a sample V-Ramp program running on Agilent 4155/4156, and how to use and customize the program. The program is written in the Instrument BASIC (IBASIC), and is ready to run on the built-in IBASIC controller of the 4155/4156.

“Theory of V-Ramp Test Procedure” describes basic theory, procedure, and terminology of the V-Ramp test.

“Basic Operation” describes the V-Ramp sample program. Included are V-Ramp methodology using the 4155/4156, how to execute the sample program, and program overview.

“Customization” describes how to customize the sample program. This is very helpful because you probably need to modify the sample program to suit your test device.

“Measurement Setups” shows the 4155/4156 page settings that are stored in the setup files.

## Theory of V-Ramp Test Procedure

This section describes the Voltage-Ramped (V-Ramp) Test procedure. Included are basic theory, procedure, and terminology of V-Ramp test. The V-Ramp test procedure is based on JEDEC standard No.35.

### V-Ramp Test Overview

V-Ramp test measures the breakdown voltage ( $V_{bd}$ ) and breakdown charge ( $Q_{bd}$ ) of thin oxide capacitors, which you designed as test structures on the wafer. These results are used to evaluate the oxide integrity. The higher the  $V_{bd}$  and  $Q_{bd}$  measured by this test, the better the integrity of the oxide on wafer.

You extract these two parameters from a large amount of test structures and extracted parameters are used for standard process control to quickly evaluate oxide integrity.

In the V-Ramp test, an increasing voltage is forced to the oxide capacitor until the oxide layer is broken. Breakdown voltage ( $V_{bd}$ ) is defined as the voltage at which breakdown occurs. And breakdown charge ( $Q_{bd}$ ) is the total charge forced through the oxide until the breakdown occurs.

Figure 1-1 shows a simplified flowchart of V-Ramp test.

Figure 1-1

Simplified Flow Diagram of V-Ramp Test

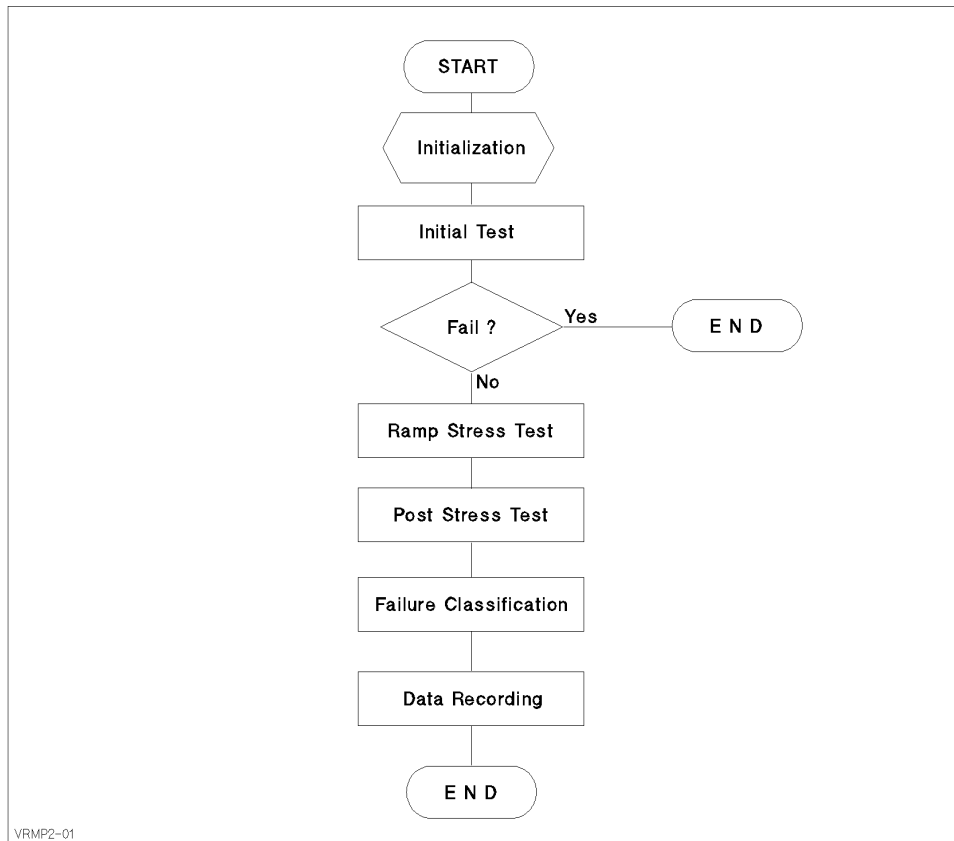

The V-Ramp test consists of three tests: initial test, ramp stress test, and post stress test.

In the initial test, normal operating voltage is applied to the oxide capacitor, then leakage current through the capacitor is measured to check for initial failure.

In the ramp stress test, linear ramped voltage is applied to the capacitor, and the current is measured.

The post stress test is for confirming that failure occurred during the ramp stress test. The normal operating voltage is applied to the oxide capacitor again, and leakage current is measured under the same conditions as the initial test.

After the tests, the test results must be analyzed and saved (data recording).

Before performing the V-Ramp test, test conditions must satisfy the following:

- Gate bias polarity is in accumulated direction. That is, negative (minus) voltage is applied to gate conductor for P-type bulk, and positive (plus) voltage is applied for N-type bulk.
- Diffusions and wells (if any) must be connected to substrate.
- Temperature is in  $25 \pm 5$  °C range.

## Initial Test

Initial test is to confirm that the oxide capacitor is initially good. If leakage current of that capacitor exceeds  $1 \mu\text{A}$ , it is categorized as **initial failure**.

For example, when you test a TTL-level oxide capacitor, constant voltage of  $-5$  V is applied to that capacitor, and leakage current is measured. If the leakage current is more than  $1 \mu\text{A}$ , that capacitor is an initial failure.

## Post Stress Test

The post stress test checks the oxide status after the ramp stress test. If the oxide is broken, proper ramp stress was applied to the oxide capacitor. If not, maybe the ramp stress was not applied correctly.

To check the oxide status, the normal operating voltage is applied to the oxide capacitor (same as initial test), then leakage current is measured. The leakage current ( $I_{\text{leak}}$ ) value indicates the following:

- If  $I_{\text{leak}} > 1 \mu\text{A}$ :  
The oxide was broken by the applied ramped voltage.
- If  $I_{\text{leak}} < 1 \mu\text{A}$ :  
The oxide was *not* broken by the applied ramped voltage.

If the applied ramped voltage reached the maximum electric field, the testing was probably faulty: for example, the ramped voltage was not applied to the oxide due to an open circuit.

For example, if you test a TTL level oxide capacitor, constant voltage of  $-5$  V is applied to that capacitor, then leakage current is measured. If the leakage current is more than  $1 \mu\text{A}$ , the capacitor was properly broken.

## Ramp Stress Test

A linear ramped voltage or a linear stepped voltage, which is approximately ramped voltage, is applied to the oxide capacitor. While the ramped voltage is forced, the current through the oxide is measured.

The ramped voltage is stopped when one of the following conditions occurs:

- Current through the oxide exceeds ten times the expected current. The expected current is calculated from the applied voltage and structure of oxide capacitor. For example, the expected current density  $J$  for a 200 angstrom oxide capacitor is calculated from the equation for Fowler-Nordheim current as follows:

$$J = A \cdot E^2 \exp\left(-\frac{B}{E}\right)$$

Where,  $A$  and  $B$  are constants in terms of effective mass and barrier height.  $E$  is electric field.

- Current through the oxide exceeds the current compliance determined by the current density compliance limit of  $20 \text{ A/cm}^2$ .
- Electric field generated by the applied voltage exceeds  $15 \text{ MV/cm}$ . This typically indicates *faulty testing*.

Figure 1-2 shows the concept of  $V_{bd}$  and  $Q_{bd}$ . In the graph, left vertical axis shows current through the oxide, right vertical axis shows voltage applied to the oxide capacitor, and horizontal axis shows time.

When the current through the oxide reaches 10 times the expected current, the ramped voltage is stopped, and the applied voltage at this point is the breakdown voltage ( $V_{bd}$ ). Breakdown charge ( $Q_{bd}$ ) is calculated by integrating the current through the oxide:

$$Q_{bd} = \int_{T_{start}}^{T_{bd}} I_{meas}(t) dt$$

Figure 1-2

Concept of Breakdown Voltage and Charge

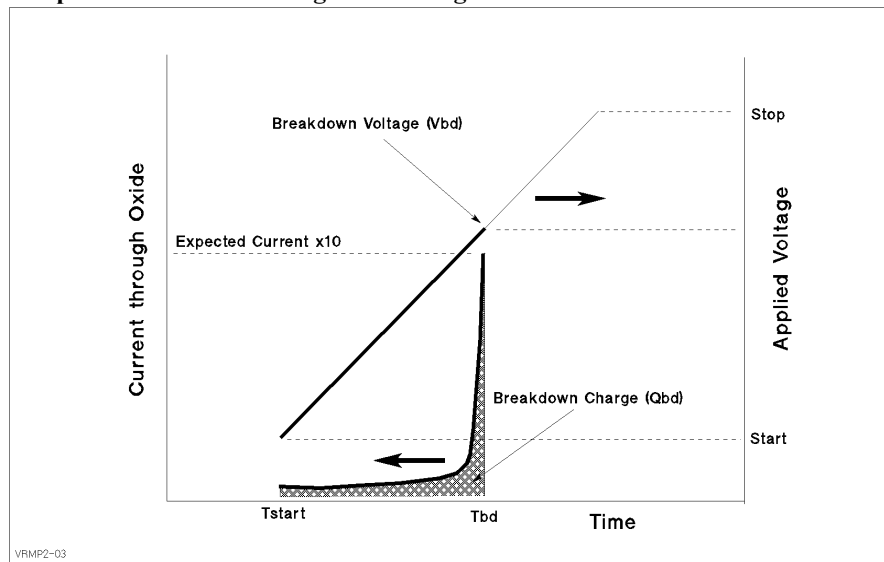

Figure 1-3 shows the two ways to apply the voltage: linear ramped voltage or linear stepped voltage.

Note that the applied ramped voltage must satisfy the following conditions:

- Ramp rate is in range from 0.1 MV/cm·s to 1.0 MV/cm·s.
- Current measurement interval is 0.1 s or less.
- Ramped voltage starts at normal operating voltage or lower.
- Ramped voltage stops if electric field reaches 15 MV/cm.

If you use the linear stepped voltage, the following conditions must be satisfied also:

- Step value of ramped voltage is 0.1 MV/cm or less.
- Current measurement must be performed at least once for every step.

Figure 1-3

### Linear Ramped and Linear Stepped Voltage

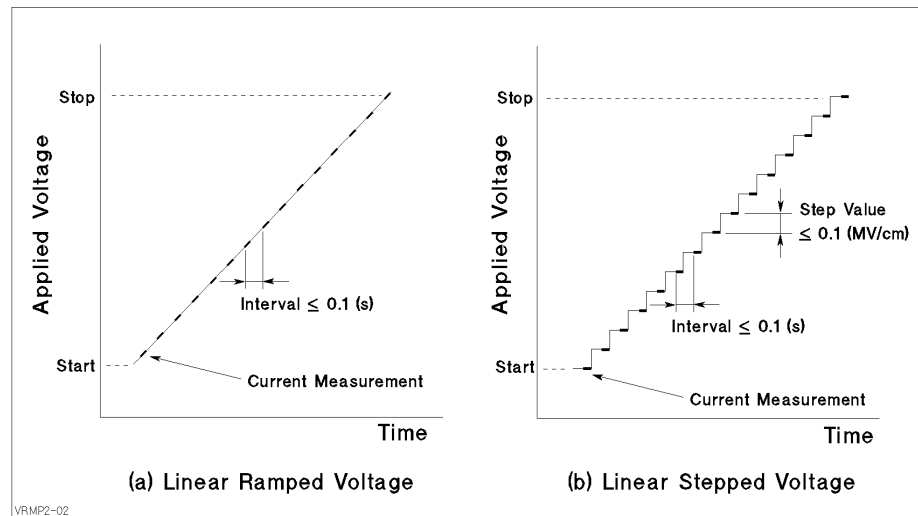

## Failure Categorization and Data Recording

According to the measurement results, the oxide status is categorized as follows and recorded:

- Initial Failure:** Failed the initial test. Indicates initially defective oxide capacitor. Other tests should not be performed.
- Catastrophic Failure:** Failed ramped and post stress tests. Indicates that oxide capacitor was properly broken by the ramped stress test.
- Masked Catastrophic Failure:** Did not fail ramped stress test, but failed post stress test.
- Non-catastrophic Failure:** Failed ramped stress test, but not post stress test.
- Other** Did not fail ramped stress test or post stress test.

The failure category is recorded for each test device. If the catastrophic failure is observed, breakdown voltage ( $V_{bd}$ ) and breakdown charge density ( $q_{bd} = Q_{bd}/Area$ ) are also recorded.

Table 1-1 shows the oxide failure categories.

**Table 1-1 Oxide Failure Categories**

Failure Category	Initial Test	Ramp Stress Test	Post Stress Test
Initial	Fail	n.a.	n.a.
Catastrophic <sup>a</sup>	Pass	Fail	Fail
Masked Catastrophic	Pass	Pass	Fail
Non-catastrophic	Pass	Fail	Pass
Other	Pass	Pass	Pass

a.  $V_{bd}$  and  $q_{bd}$  are also recorded.

## Basic Operation

This section covers the following for using an 4155/4156 to perform V-Ramp Test: required equipment, required files, methodology, how to execute the sample program, and sample program overview.

### Methodology

The entire V-Ramp Test procedure can be performed by executing the VRAMP sample program on the built-in IBASIC controller of the 4155/4156.

As explained in “Theory of V-Ramp Test Procedure”, the V-Ramp test consists of three measurement parts and an analysis part. Each measurement part executes three steps as follows:

1. Loads the measurement setup file into the 4155/4156 execution environment.
2. Changes some of the measurement or analysis parameters on the setup pages.
3. Executes the measurement.

The VRAMP program executes the above three steps for each test: initial test, ramp stress test, and post stress test. Using the measurement setups (step 1 above) loaded from a file reduces the length and complexity of the program. For details, see *Programmer's Guide*.

Measurement setups, which are loaded into the 4155/4156 execution environment, were previously developed and saved to measurement setup files on the diskette. You can easily modify the measurement setup information in fill-in-the-blank manner in the 4155/4156 execution environment. The VRAMP sample program is also saved to the diskette. You can easily modify the sample program by using the editor in the built-in IBASIC environment.

The VRAMP sample program assumes that the built-in IBASIC controller of the 4155/4156 is used, but you can also use another controller, such as HP BASIC running on an external computer. To do so, you must modify the sample program for your environment. See “Customization” on how to modify the program to run on an external controller.

### Initial Test

The initial test makes sure the oxide capacitor is initially good by applying the normal operating voltage ( $V_{use}$ ), then measuring the leakage current ( $I_{leak}$ ) through the oxide. If  $I_{leak}$  exceeds  $1 \mu A$ , the oxide capacitor is categorized as "initial failure".

The sample program assumes that SMU1 and SMU4 are connected to the oxide capacitor as shown in Figure 1-4.

For the initial test, the sample program does as follows:

1. Sets up the 4155/4156 according to the VRSPOT.MES setup file, which the sample program previously loaded from the diskette into internal memory MEM1.
2. Sets up SMU1 to constant voltage  $V_{use}$  for PMOS device, or  $-V_{use}$  for NMOS device.  $V_{use}$  value is specified previously in the sample program, and reset on the MEASURE: SAMPLING SETUP page by OUTPUT statement (line 2550 of the sample program).
3. Forces voltage from SMU1, then measures current after the HOLD TIME, which was setup by VRSPOT.MES setup file described next.
4. Checks if current through the oxide  $I_g$  exceeds  $1 \mu\text{A}$ . If so, the sample program aborts further testing.

The following are main points about the setup by the VRSPOT.MES setup file:

- On CHANNELS: CHANNEL DEFINITION page (see Figure 1-13)
  - MEASUREMENT MODE is set to SAMPLING.
  - SMU1 and SMU4 are set to be constant voltage sources.
  - $I_g$  is defined as name of current measured by SMU1.
- On MEASURE: SAMPLING SETUP page (see Figure 1-5)
  - NO. OF SAMPLES is set to 1 to execute the measurement once.
  - HOLD TIME is set to 2.00 s to allow the output voltage to stabilize.
  - SMU4 is set to force a constant 0 V.
  - STOP CONDITION is enabled, NAME is set to  $I_g$ , THRESHOLD is set to  $1 \mu\text{A}$ , and EVENT is set to  $V_{al} > Th$ .

So, the measurement will stop if the current through the oxide ( $I_g$ ) exceeds  $1 \mu\text{A}$ . If so, the sample program will abort further testing.

**Figure 1-4** Simplified Measurement Circuit and Output Voltage of Initial Test

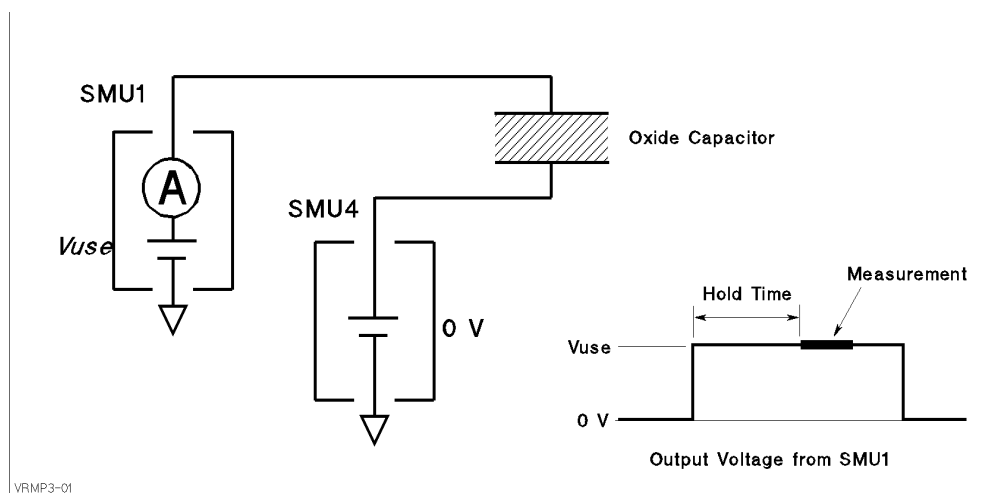
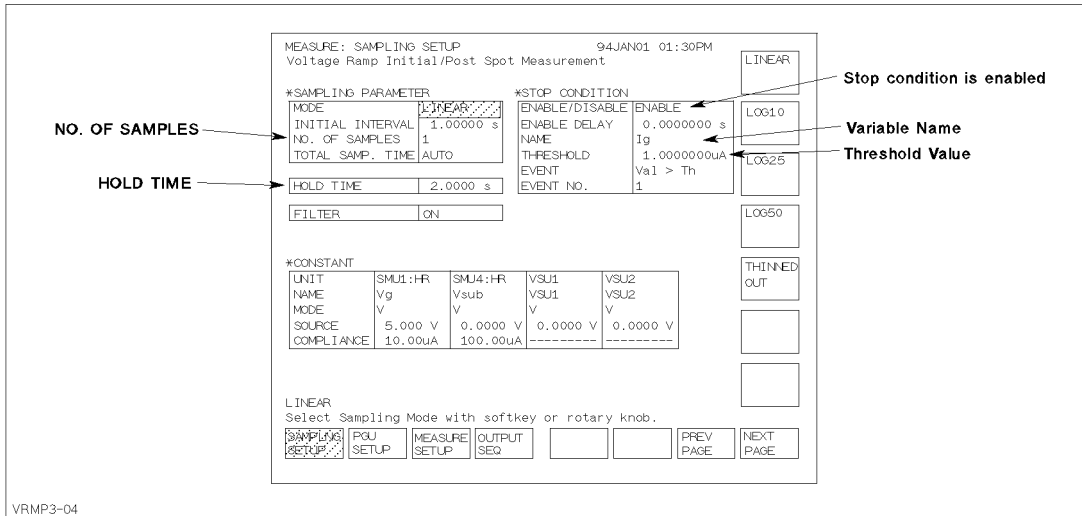

Figure 1-5 MEASURE: SAMPLING SETUP Page for Initial Test



## Ramp Stress Test

After the initial test, the sample program executes the ramp stress test. Linear stepped voltage is applied to the oxide.

The measurement setup for the ramp stress test is stored in the VRSWEP.MES setup file on the diskette. At the beginning of the sample program, this setup is loaded into internal memory (MEM2). Then, at the beginning of the ramp stress test, the sample program loads this setup into the 4155/4156.

To force proper stepped voltage, the sample program and VRSWEP.MES set the following:

- SMU channel definition (see Figure 1-6):  
SMU4 is set to force a constant 0 V, and SMU1 is set to voltage sweep mode.
- Constant step interval time (see Figure 1-8):  
Step interval time of output sweep voltage must be constant.
- Measurement stop mode:  
If the current through the oxide reaches the specified compliance, the voltage sweep and measurement stops.
- Auto-analysis and user functions:  
After the measurement, the 4155/4156 executes analysis automatically to search for  $V_{bd}$ , and to calculate  $Q_{bd}$ .

**SMU Channel Definition.**

The sample program assumes the connection between the SMUs and the oxide capacitor as shown in Figure 1-6. SMU4 is set to force a constant 0 V, and SMU1 is set to voltage sweep mode by the VRSWEP.MES setup as shown in Figure 1-7.

**Figure 1-6** Simplified Measurement Circuit of Ramp Stress Test

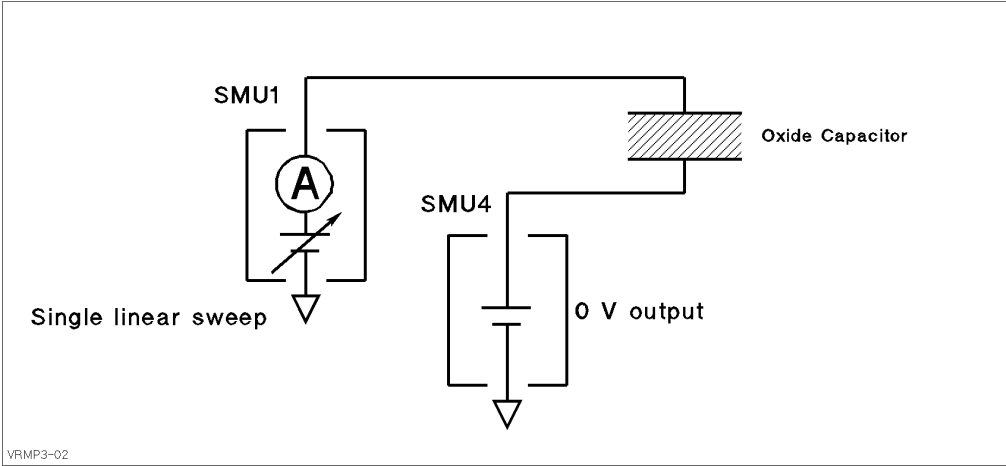

**Figure 1-7** CHANNELS: CHANNEL DEFINITION Page for Ramp Stress Test

CHANNELS: CHANNEL DEFINITION 94JAN01 01:30PM  
Voltage Ramp Sweep Measurement

\*MEASUREMENT MODE  
SWEEP

\*CHANNELS

UNIT	VNAME	INAME	MODE	FCTN	STBY	SERIES RESISTANCE
SMU1:HR	Vg	Ig	V	VAR1		0 ohm
SMU2:HR						
SMU3:HR						
SMU4:HR	Vsub	Isub	V	CONST		0 ohm
SMU5:HP						
VSU1	VSU1		V	CONST		
VSU2	VSU2		V	CONST		
VMU1	VMU1		V			
VMU2	VMU2					
PGU1						
PGU2						
GNDU						

SWEEP  
Select Measurement Mode with softkey or rotary knob.

CHANNELS USER USER NEXT  
DEF FCTN VAR PAGE

Annotations:  
 - SMU1 and SMU4 are connected to the oxide capacitor. (points to SMU1 and SMU4 rows)  
 - SMU1 is sweep source VAR1. (points to VAR1 in FCTN column)  
 - SMU4 is constant source. (points to CONST in FCTN column)

### Constant step interval time.

To keep a constant step interval time for the voltage sweep and measurement, triggering and measurement ranging techniques are used. VRSWEP.MES sets the measurement ranging mode to FIXED, so the time between measurements does not vary due to range changing.

VRSWEP.MES enables the TRIG OUT function, and the sample program calculates and sets values so that the step interval time becomes constant as shown in Figure 1-8. The *step interval time* ( $Step\_time$ ) is the *delay time* ( $Step\_delay\_t$ ) plus *step delay time* ( $Step\_keep\_t$ ). Strictly speaking, the sample program calculates these as follows:

```
Step_time=Vstep/(Ramp_rate*Tox)-1.2ms+0.1ms
Step_delay_t=Step_time/2
Step_keep_t=Step_time-Step_delay_t
```

Where,

- 1.2 ms is overhead time associated with the *delay time* for voltage sweep measurement, when the WAIT TIME field is set to 0 (zero). So, do not set another value in this field.
- 0.1 ms is overhead time associated with the TRIG OUT function.
- Ramp rate ( $Ramp\_rate$ ), oxide thickness ( $Tox$ ), and step voltage ( $Vstep$ ) are specified in lines 1800 to 1840 of the sample program.

The start voltage ( $Vstart$ ), stop voltage ( $Vstop$ ), and step voltage ( $Vstep$ ) are specified in sample program in lines 1830 to 1850. For NMOS devices, the ramp stress test subprogram actually sets the opposite polarity for these values by using the  $Tp$  variable.

### Measurement stop mode.

#### NOTE

The JEDEC standard says that the ramp stress test should abort when the current through the oxide reaches 10 times the expected current ( $I_{expect}$ ). But this sample program aborts when the current reaches current compliance ( $I_{gcomp}$ ). The  $I_{expect}$  and  $I_{gcomp}$  values are specified in lines 1860 and 1870 of the sample program, and must meet the following condition:  $I_{gcomp} \geq I_{expect} \times 10$ .

VRSWEP.MES file sets the sweep stop condition to SWEEP STOP AT COMPLIANCE as shown in the Figure 1-10.

Figure 1-8 Output Sweep Voltage for Ramp Stress Test

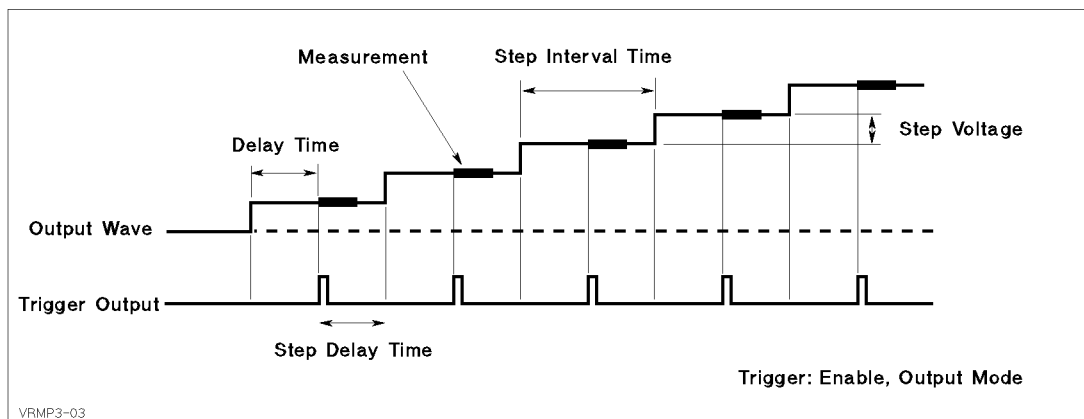

Figure 1-9 MEASURE: MEASURE SETUP and OUTPUT SEQUENCE Pages for Ramp Stress Test

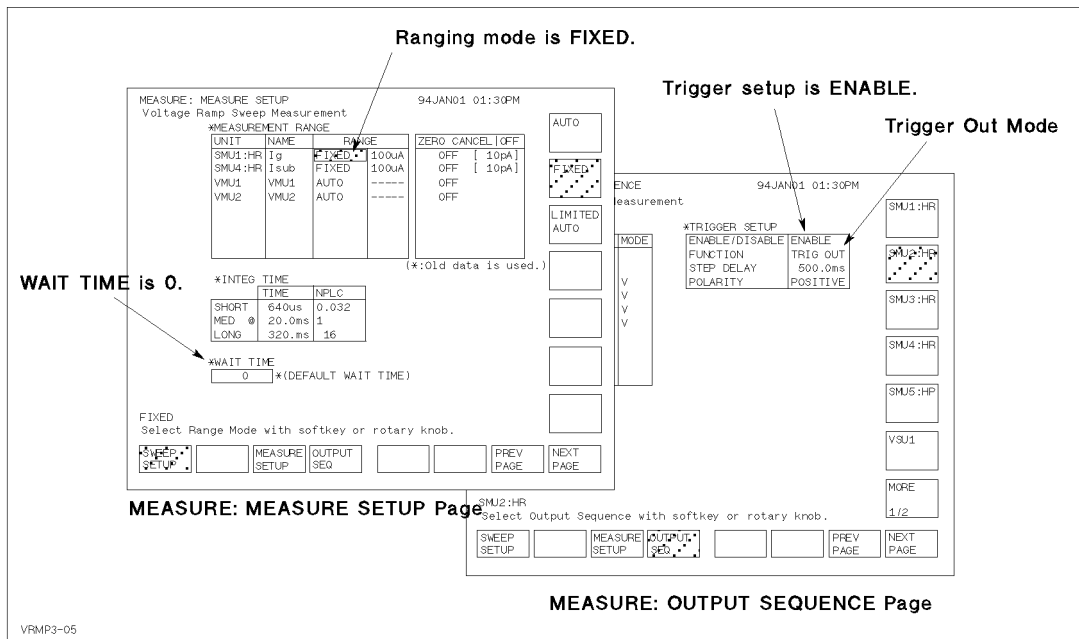
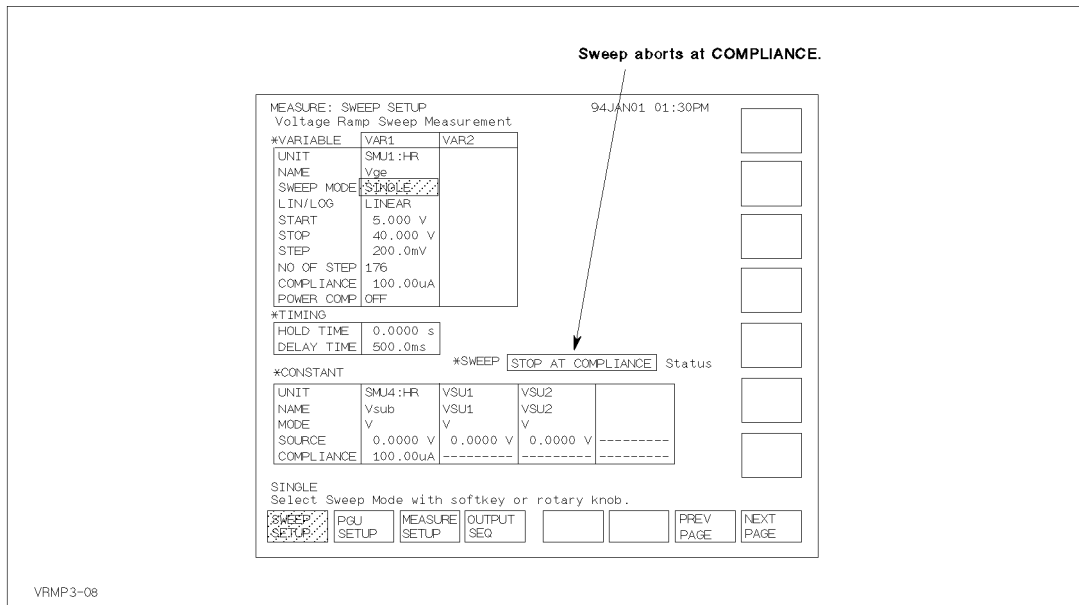

Figure 1-10 MEASURE: SWEEP SETUP Page for Ramp Stress Test



**Auto-analysis and user functions.**

The sample program does the following:

1. Sets up the maximum and minimum values for graph axes: X, Y1, and Y2. Lines 2940 to 2980.
2. Performs the measurement. Line 3020.
3. Moves marker to maximum  $I_g$ , and saves value to  $I_{gmax}$ . Lines 3100 to 3170.
4. Moves marker to position where  $I_g = I_{expect} * 10$ . Line 3200.
5. If compliance was reached or if  $I_{gmax} \geq I_{expect} * 10$ , the sample program reads the value of  $V_{bd}$  and  $Q_{bd}$  at present marker position. Lines 3250 to 3320. Where  $V_{db}$  and  $Q_{bd}$  are specified as described below.

The VRSWEP.MES setup file defines user functions on the CHANNELS: USER FUNCTION DEFINITION page (see Figure 1-20) as follows:

**Table 1-2**

**User Functions for Ramp Stress Test**

Name	Units	Definition
Time	(sec)	@INDEX * 1 <sup>a</sup>
Vbd	(V)	@MY2
Qbd	(Q)	INTEG(Ig,Time)

- a. This is a temporary value. Value of Time is redefined by line 2810 of the sample program.

The above user function calculates  $Q_{bd}$  as follows:

$$Q_{bd} = \int_{T_{start}}^{T_{bd}} I_{meas}(t) dt = \frac{1}{2} \sum_{i=2}^N (I_{meas}_i + I_{meas}_{i-1}) \times (T_i - T_{i-1})$$

Where,  $N$  is step number when the breakdown occurs.

## Post Stress Test

Post stress test checks the oxide status after the ramp stress test.

The methodology of the post stress test is the same as for initial test. The normal operating voltage ( $V_{use}$ ) is applied to the oxide, then the leakage current ( $I_{leak}$ ) is measured.

For the measurement circuit, connections, and measurement setups, see “Initial Test”.

## Failure Categorization

Table 1-3 shows the oxide failure categories that are determined by the sample program. The failure category is displayed for each device, and  $V_{bd}$ ,  $Q_{bd}$ , and  $q_{bd}$  are also displayed.

The measured data and measurement settings are saved in a file.

Table 1-3

Oxide Failure Categories

Category	Initial Test	Ramp Stress Test	Post Stress Test
Initial	$I_{meas} > 1 \mu A$	n.a.	n.a.
Catastrophic	$I_{meas} \leq 1 \mu A$	$I_{meas} \geq I_{expect} \times 10$ , or I compliance reached.	$I_{meas} > 1 \mu A$
Masked Catastrophic	$I_{meas} \leq 1 \mu A$	$I_{meas} < I_{expect} \times 10$ , and I compliance not reached.	$I_{meas} > 1 \mu A$
Non-catastrophic	$I_{meas} \leq 1 \mu A$	$I_{meas} \geq I_{expect} \times 10$ , or I compliance reached.	$I_{meas} \leq 1 \mu A$
Other	$I_{meas} \leq 1 \mu A$	$I_{meas} < I_{expect} \times 10$ , and I compliance not reached.	$I_{meas} \leq 1 \mu A$

## Required Equipment

The following equipment is required to use the V-Ramp sample program:

- Agilent 4155 or Agilent 4156 Semiconductor Parameter Analyzer
- Two triaxial cables
- Probe station
- This operation manual
- Diskette that contains sample program file and two setup files

## Files on the Diskette

The following files are stored in the sample diskette:

<b>VRAMP</b>	V-Ramp sample program. This is an IBASIC program file saved in ASCII format.
<b>VRSPOT.MES</b>	Measurement setup file for initial and post stress test.
<b>VRSWEP.MES</b>	Measurement setup file for ramp stress test.

## Executing the VRAMP Program

Before executing the program, you may need to customize the program to suit your test device. See "Customization".

To execute the sample program, use the following procedure:

1. Connect your 4155/4156 to your test device. See Figure 1-4.
2. Turn on your 4155/4156.
3. Insert the diskette containing the VRAMP program into the built-in 3.5 inch flexible disk drive.
4. Press **Display** key in the IBASIC area of the front panel until All IBASIC screen is displayed.
5. Load the VRAMP program. Type: GET "VRAMP" and press **Enter** key.
6. Press **RUN** key in the IBASIC area of the front panel to start the program.

Measurement results similar to Figure 1-11 will be displayed on the GRAPHICS page of the 4155/4156.

**Figure 1-11 An Example of Measurement Results**

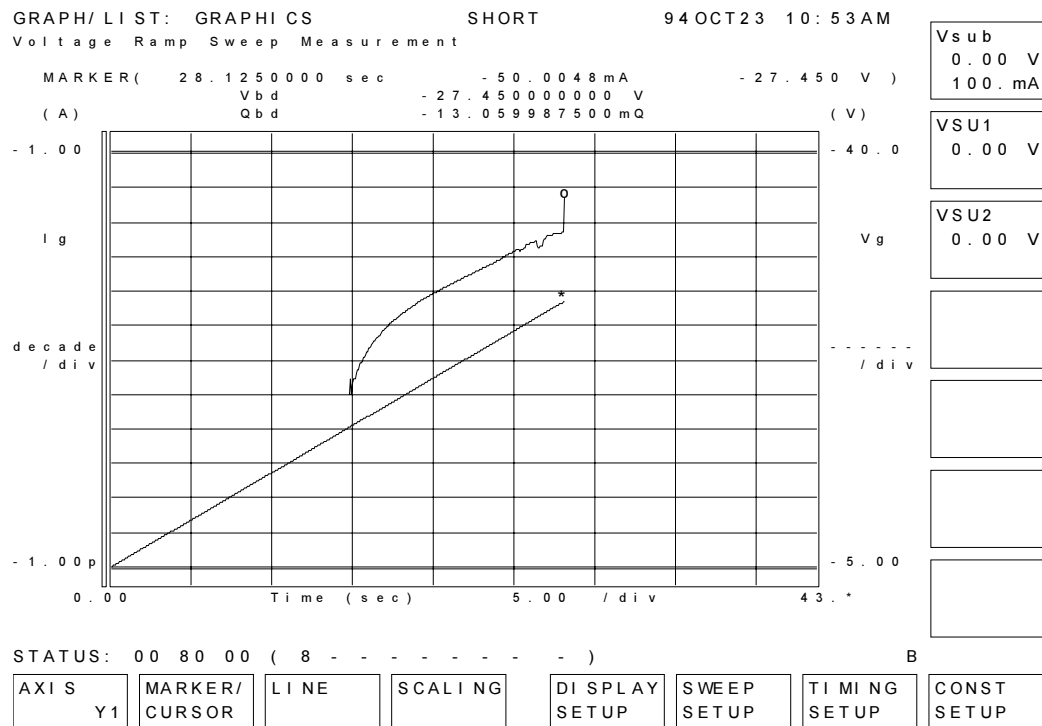

Note that this example is obtained when the maximum electric field is set to 50 MV/cm.

## Flowchart of Sample VRAMP Program

Figure 1-12 shows flowchart of sample VRAMP program and corresponding subprogram names.

Figure 1-12 Flowchart of Sample VRAMP Program

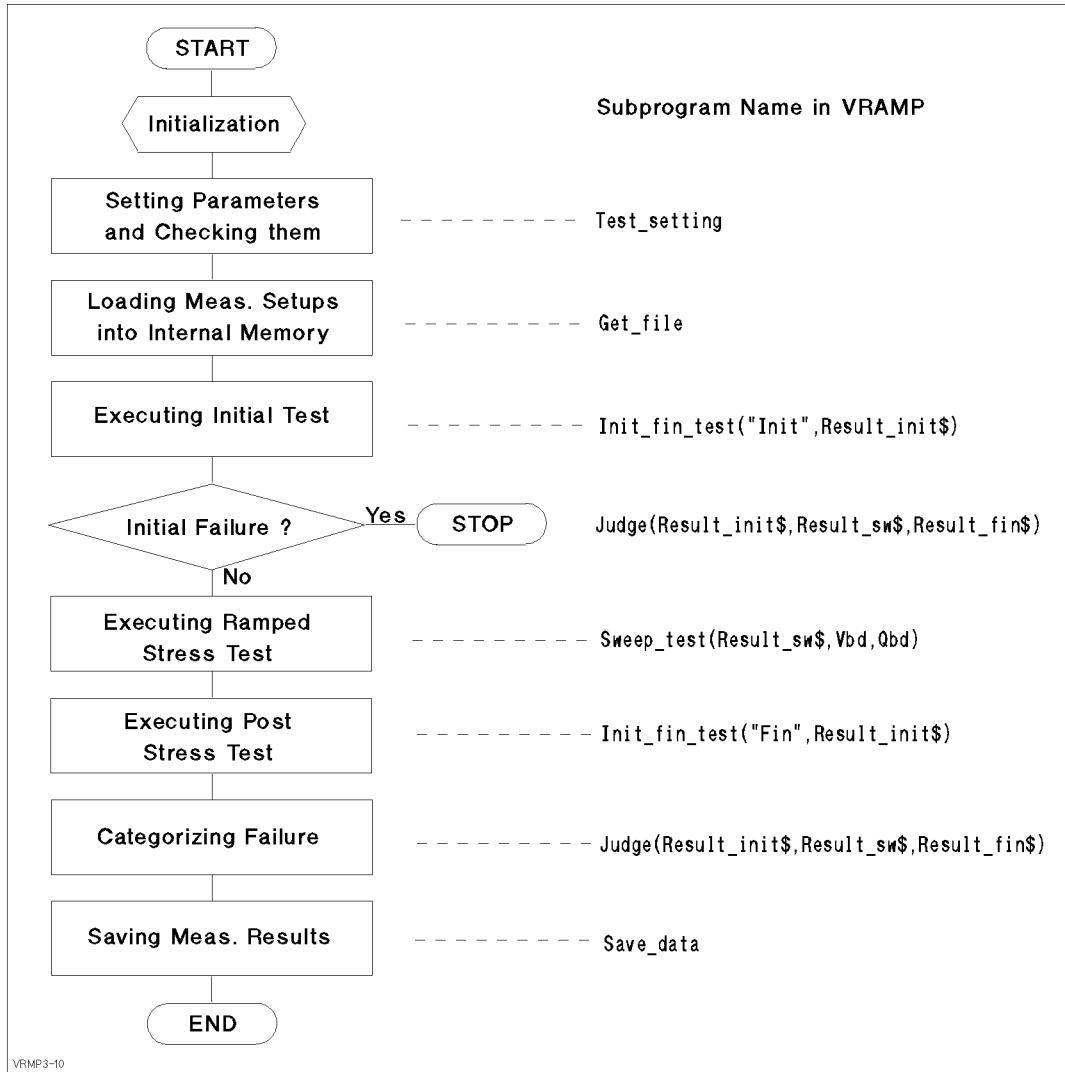

The following provides a brief description for each subprogram.

<b>Test_setting</b>	Specifies and checks the parameter values. These are values that the program will set directly instead of some of the setup file values.
<b>Get_file</b>	Loads measurement setup files from the diskette into internal memory: spot measurement setup into MEM1, and sweep measurement setup into MEM2. Having the measurement setups in internal memory reduces the measurement time.
<b>Init_fin_test</b>	Executes the spot measurement for initial test or for post stress test. First parameter specifies the test: <i>Init</i> is for initial test, and <i>Fin</i> is for post stress test. The measurement results are returned to the second parameter.
<b>Judge</b>	Categorizes failure according to measurement results of initial, ramped stress, and post stress tests. If the failure is initial failure, this subprogram aborts the program.
<b>Sweep_test</b>	Executes sweep measurement for ramped stress test, then returns the result flag, $V_{bd}$ , and $Q_{bd}$ to the three parameters. The measurement result data is temporarily stored in internal memory (MEM3).
<b>Save_data</b>	Saves measurement result data (that is in MEM3) to a file on the diskette.

---

## Customization

This section describes how to customize the sample program to suit your test device.

### Using an External Computer

This sample program (VRAMP) is assumed to run on the Instrument BASIC that is built into the 4155/4156. The 4155/4156 is used as both the measurement instrument and the controller running IBASIC, so VRAMP sets device selector *800*. On the following three lines, the 4155/4156 is assigned and interrupt from it is enabled as follows:

```
1470 ASSIGN @Hp4155 TO 800
      :
1540 ON INTR 8 CALL Err_check
1550 ENABLE INTR 8;2
```

If you use an external controller (that can run HP BASIC environment) to control the 4155/4156, you need to modify a few lines of the sample program. For example, if you use HP BASIC/WS on an HP 9000 Series 300 computer, you only need to modify lines the above three lines as follows:

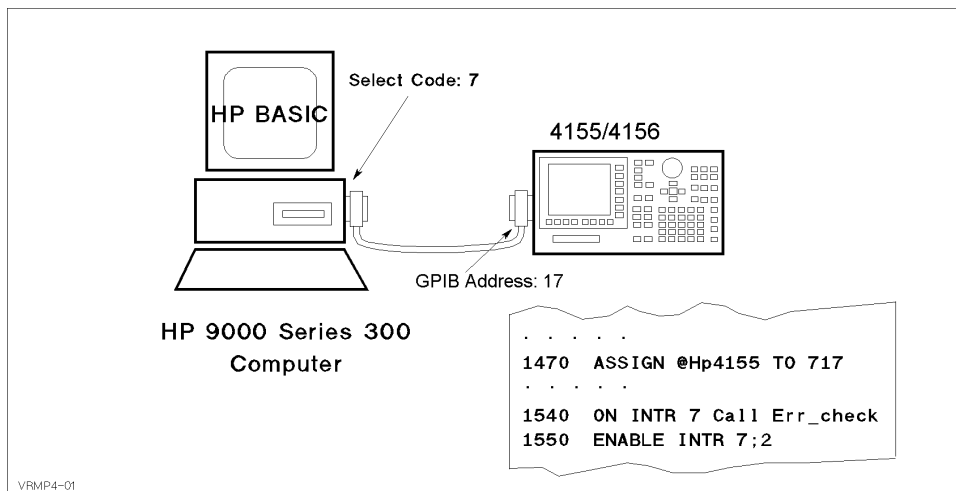

In this case, the 4155/4156 has GPIB address 17 and is not used as the system controller, and is connected to the built-in GPIB of the HP 9000 series 300 controller with a GPIB cable. Use the following procedure to set the GPIB address and system mode:

1. Turn on your 4155/4156.
2. Press **System** key.
3. Select MISCELLANEOUS softkey.
4. Move the field pointer to the "415x is " field, then select the NOT CONTROLLER softkey.
5. Move the field pointer to the "415x" field in the GPIB ADDRESS area, then enter: 17.

SYSTEM: MISCELLANEOUS 99DEC10 04:42PM

System Mode: \* 4156B is NOT SYSTEM CONTROLLER

GPIB Address: \* GPIB ADDRESS  
4156B HARD COPY 17 1

\* REMOTE CONTROL  
COMMAND SET 4155/4156

\* CLOCK  
Y M D H M  
1999 12 10 16 42

\* SYSTEM SETUP  
BEEP ON  
SCREEN SAVE 30 min  
LP TIMEOUT 300 sec

\* POWER LINE FREQUENCY  
50 Hz

\* 4156B NETWORK SETUP  
HOST NAME  
IP ADDRESS 0.0.0.0  
USER ID 200  
GROUP ID 100

\* NETWORK PRINTER SETUP  
PRINTER  
IP ADDRESS 0.0.0.0  
TEXT OUT -h  
GRAPH OUT -h -l  
SERVER TYPE BSD

\* NETWORK DRIVE SETUP  
LABEL  
IP ADDRESS 0.0.0.0  
DIRECTORY /

CON-TROLLER  
NOT CON-TROLLER

NOT SYSTEM CONTROLLER  
Select System Control Mode with softkey or rotary knob.

FILER MISCEL- CONFIG CALI B/ PRINT COLOR  
LANEOUS LANEOUS DIAG SETUP SETUP

## Specifying Setup File to Load

Two setup files are used to set up the 4155/4156 for the V-Ramp test: one is used for initial and post stress tests, and the other is for ramp stress test.

Filenames of these setups are defined on the following lines:

```
1730 Init_file$="VRSPOT.MES" !Spot Measurement Setup File Name
1740 Sweep_file$="VRSWEP.MES" !Sweep Measurement Setup File Name
```

If you want to use other setup files, store the setup files on the diskette, then modify the filenames on the lines above.

## File for Saving Measurement Results

The following lines specify the filename for the measurement results file. The filename starts with "D", then *HHMMSS*, then ends with ". DAT". Where *HH* is hour, *MM* is minute, and *S* is second (tens digit only).

```
1750 Save_file$=TIME$(TIMEDATE) !File Name for saving measurement
results
1760 Save_file$="D"&Save_file$[1,2]&Save_file$[4,5]&Save_file$[7,7]&".D
AT"
```

The following line commands the 4155/4156 to create the specified file on the diskette, then stores the result data in the file.

```
3860 OUTPUT @Hp4155;":MMEM:STOR:TRAC DEF,'"&Save_file$&'",'DISK''
```

For example, "D09344 . DAT" file that contains measurement data is created on the diskette. This filename means the "data file created at 9:34 4x seconds."

To change to your desired filename, you only need to edit line 1760.

## Setting up Input Parameters

Input parameter values are specified on the following lines. These are values that the sample program will set directly instead of using some of the setup file values. You can easily modify the values by editing these program lines.

```

1780 Type$="NMOS"           ! Type NMOS -- Pbulk, PMOS -- Nbulk
1790 Vuse=5                 ! Vuse (V)
1800 Ramp_rate=.5*1.E+6    ! Ramp rate (MV/cm*s)
1810 Tox=160*1.E-8        ! Oxide Thickness (cm)
1820 Area=.001             ! Gate Area (cm^2)
1830 Vstart=5              ! Start voltage (V)
1840 Vstop=24              ! Stop voltage (V)
1850 Vstep=.05             ! Step voltage (V)
1860 Iexpect=.003         ! Expected breakdown current (A)
1870 Igcomp=.05           ! Ig compliance (A)

```

Parameter	Default	Description
Type\$	NMOS <sup>a</sup>	Bulk type: NMOS is for P bulk and PMOS is for N bulk
Vuse	5 (V)	Normal operating voltage for the device
Ramp_rate	5.0×10 <sup>5</sup> (MV/cm.s)	Ramp rate of stepped voltage
Tox	1.60×10 <sup>-6</sup> (cm)	Thickness of oxide
Area	0.001 (cm <sup>2</sup> )	Area of target oxide
Vstart	5 (V)	Start voltage
Vstop	24 (V)	Stop voltage
Vstep	50 (mV)	Step voltage
Iexpect	3 (mA)	Expected current through the oxide
Igcomp	50 (mA)	Current compliance through the oxide

- a. If type is NMOS, opposite polarity values for the voltages are actually used later in the program by using the  $t_p$  parameter, which is set to -1 in line 1880.

## Searching for $10 \times I_{\text{expect}}$

In the VRAMP program,  $I_{\text{expect}}$  is set to 0.003 A in line 1860 of the program. However, this is a very simple method and might not give accurate results.

$I_{\text{expect}}$  is the expected current through the oxide, and is a function of the electric field  $E$ . So, the actual  $I_{\text{expect}}$  depends on the applied voltage.

To get more accurate results, you can plot a graph of  $I_{\text{expect}}$  versus  $V_g$  by using the Fowler-Nordheim equation:

$$J = A \cdot E^2 \exp\left(-\frac{B}{E}\right)$$

Where:  $A$  and  $B$  are constants in terms of effective mass and barrier height.  $E$  is electric field.

The oxide capacitor of MOS can be considered to be a parallel plate capacitance, so the oxide thickness ( $T_{\text{ox}}$ ) and its area ( $\text{Area}$ ) results in the following:

$$I_{\text{expect}} = \text{Area} \cdot J = \text{Area} \cdot A \cdot \left(\frac{V}{T_{\text{ox}}}\right)^2 \exp\left(-\frac{B \cdot T_{\text{ox}}}{V}\right) = \frac{\text{Area} \cdot A}{T_{\text{ox}}^2} \cdot V^2 \cdot \exp\left(-\frac{B \cdot T_{\text{ox}}}{V}\right) = \alpha \cdot V^2 \cdot \exp\left(\frac{\beta}{V}\right)$$

Where:  $V$  is applied voltage.

To draw the curve for the above equation, you can use a *user function*. For example, when  $\alpha=100$  and  $\beta=-415$ , you set the following user function on the CHANNELS: USER FUNCTION page:

NAME	UNIT	DESCRIPTION
Iexp	A	100*Vg^2*EXP(-415/Vg)

So, after the measurement finishes, you set up  $V_g$  for the X-Axis,  $I_g$  for the Y1 axis, and  $I_{\text{exp}}$  for the Y2 axis on the DISPLAY: DISPLAY SETUP page.

Also, set up analysis so that the marker will move automatically to the point on the curve where  $I_g$  is equal to  $10 \times I_{\text{exp}}$ . In the DISPLAY: ANALYSIS SETUP page, you would set as follows:

```
*MARKER: At a point where
  [Ig      ] = [10*Iexp      ]
  [        ]
```

This method allows you to find more accurately the  $V_{\text{bd}}$ , which is the value of  $V_g$  where  $I_g$  is equal to  $10 \times I_{\text{exp}}$ .

## Measurement Setups

This section covers the measurement setups that are stored in the VRSPOT.MES and VRSWEP.MES files.

### Setups for Initial and Post Stress Tests

The measurement setups stored in VRSPOT.MES are used for the initial and post stress tests. The setups of each page are shown in Figure 1-13 to Figure 1-18.

### Setups for Ramped Stress Test

The measurement setups that are stored in VRSWEP.MES are used for the ramped stress test. The setups of each page are shown in Figure 1-19 to Figure 1-25.

**Figure 1-13 CHANNELS: CHANNEL DEFINITION Page for Initial/Post Stress**

CHANNELS: CHANNEL DEFINITION 95FEB02 08:17AM  
Voltage Ramp Initial/Post Spot Measurement

\* MEASUREMENT MODE

\* CHANNELS

UNIT	MEASURE				STBY	SERIES RESISTANCE
	VNAME	I NAME	MODE	FCTN		
SMU1: HR	Vg	I g	V	CONST		0 ohm
SMU2: HR						0 ohm
SMU3: HR						
SMU4: HR	Vsub	I sub	V	CONST		
VSU1		-----				
VSU2		-----				
VMU1		-----			----	
VMU2		-----			----	

SAMPLING  
Select Measurement Mode with softkey or rotary knob.

<input type="text" value="CHANNEL DEF"/>	<input type="text" value="USER FCTN"/>	<input type="text" value="USER VAR"/>	<input type="text"/>	<input type="text"/>	<input type="text"/>	<input type="text"/>	<input type="text" value="NEXT PAGE"/>
------------------------------------------	----------------------------------------	---------------------------------------	----------------------	----------------------	----------------------	----------------------	----------------------------------------

Figure 1-14 MEASURE: SAMPLING SETUP Page for Initial/Post Stress

MEASURE: SAMPLING SETUP 95FEB02 08:19AM  
Voltage Ramp Initial/Post Spot Measurement

* SAMPLING PARAMETER		* STOP CONDITION	
MODE	LINEAR	ENABLE/ DI SABLE	ENABLE
INITIAL INTERVAL	1.00000 s	ENABLE DELAY	0.0000000 s
NO. OF SAMPLES	1	NAME	Ig
TOTAL SAMP. TIME	AUTO	THRESHOLD	1.0000000uA
		EVENT	Val > Th
		EVENT NO.	1
HOLD TIME	2.0000 s		
FILTER	ON		

UNIT	SMU1: HR	SMU4: HR		
NAME	Vg	Vsub		
MODE	V	V		
SOURCE	5.000 V	0.0000 V	-----	-----
COMPLIANCE	10.00uA	100.00uA	-----	-----

LINEAR  
Select Sampling Mode with softkey or rotary knob.

SAMPLING SETUP		MEASURE SETUP	OUTPUT SEQ			PREV PAGE	NEXT PAGE
----------------	--	---------------	------------	--	--	-----------	-----------

Figure 1-15 MEASURE: MEASURE SETUP Page for Initial/Post Stress

MEASURE: MEASURE SETUP 95FEB02 08:20AM  
Voltage Ramp Initial/Post Spot Measurement

* MEASUREMENT RANGE			
UNIT	NAME	RANGE	ZERO CANCEL OFF
SMU1: HR	Ig	LIMITED 1nA	OFF [ 10pA]
SMU4: HR	Isub	FIXED 100uA	OFF [ 10pA]

(\*: Old data is used.)

* INTEG TIME		
	TIME	NPLC
SHORT	640us	0.032
MED @	20.0ms	1
LONG	320.ms	16

\* WAIT TIME  
1 \*( DEFAULT WAIT TIME)

LIMITED  
Select Range Mode with softkey or rotary knob.

SAMPLING SETUP		MEASURE SETUP	OUTPUT SEQ			PREV PAGE	NEXT PAGE
----------------	--	---------------	------------	--	--	-----------	-----------

**Figure 1-16 MEASURE: OUTPUT SEQUENCE Page for Initial/Post Stress**

MEASURE: OUTPUT SEQUENCE 95FEB02 08:20AM  
Voltage Ramp Initial/Post Spot Measurement

* OUTPUT SEQUENCE				* TRIGGER SETUP	
	UNIT	NAME	MODE	ENABLE/DISABLE FUNCTION	DISABLE TRIGGER OUT
1	SMU2: HR				
2	SMU3: HR			STEP DELAY	0.000 s
3	SMU4: HR	Vsub	V	POLARITY	POSITIVE
4	SMU1: HR	Vg	V		
5	VSU1				
6	VSU2				

\* OUTPUT SEQUENCE MODE OF SAMPLING  
SEQUENTIAL

SMU2: HR  
Select Output Sequence with softkey or rotary knob.

SAMPLING SETUP		MEASURE SETUP	OUTPUT SEQ			PREV PAGE	NEXT PAGE
----------------	--	---------------	------------	--	--	-----------	-----------

**Figure 1-17 DISPLAY: DISPLAY SETUP Page for Initial/Post Stress**

DISPLAY: DISPLAY SETUP 95FEB02 08:21AM  
Voltage Ramp Initial/Post Spot Measurement

\* DISPLAY MODE  
GRAPHICS

\* GRAPHICS

	Xaxis	Y1axis	Y2axis
NAME	@TIME	Ig	
SCALE	LINEAR	LINEAR	
MIN	0.000000000 s	-2.000000000uA	
MAX	2.00000 s	2.000000000uA	

\* GRID ON

\* LINE PARAMETER ON

\* DATA VARIABLES  
Vg

GRAPHICS  
Select Display Mode with softkey or rotary knob.

DISPLAY SETUP	ANALYSIS SETUP					PREV PAGE	NEXT PAGE
---------------	----------------	--	--	--	--	-----------	-----------

Figure 1-18 **DISPLAY: ANALYSIS SETUP Page for Initial/Post Stress**

DI SPLAY: ANALYSIS SETUP 95FEB02 08:21AM  
 Voltage Ramp Initial/Post Spot Measurement

\*LINE1: [ ]

\*LINE2: [ ]

\*MARKER: At a point where  
 [ @NDEX ] = [ 1 ]  
 [ ]

\*Interpolate: [ OFF ]

Select Line Mode with softkey or rotary knob.

DI SPLAY SETUP   ANLYSIS SETUP   [ ]   [ ]   [ ]   [ ]   PREV PAGE   NEXT PAGE

Figure 1-19 **CHANNELS: CHANNEL DEFINITION Page for Ramped Stress**

CHANNELS: CHANNEL DEFINITION 95FEB02 08:35AM  
 Voltage Ramp Initial/Post Spot Measurement

\* MEASUREMENT MODE

\* CHANNELS

UNI T	MEASURE				STBY	SERIES RESI STANCE
	VNAME	I NAME	MODE	FCTN		
SMU1: HR	Vg	I g	V	VAR1		0 ohm
SMU2: HR						0 ohm
SMU3: HR						
SMU4: HR	Vsub	I sub	V	CONST		
VSU1		-----				
VSU2		-----				
VMU1		-----			----	
VMU2		-----			----	

SWEEP

Select Measurement Mode with softkey or rotary knob. B

CHANNEL DEF   USER FCTN   USER VAR   [ ]   [ ]   [ ]   [ ]   NEXT PAGE

**Figure 1-20 CHANNELS: USER FUNCTION DEFINITION Page for Ramped Stress**

CHANNELS: USER FUNCTION DEFINITION 95FEB02 08:37AM  
Voltage Ramp Initial/Post Spot Measurement

NAME	UNIT	DEFINITION
Time	sec	@NDEX*.0614
Vbd	V	@MY2
Qbd	C	INTEG(Ig, Time)

\* USER FUNCTION

Time  
Enter User Function Name. (max 6 chars.)

CHANNEL DEF	USER FCTN	USER VAR				PREV PAGE	NEXT PAGE
-------------	-----------	----------	--	--	--	-----------	-----------

DELETE ROW

**Figure 1-21 MEASURE: SWEEP SETUP Page for Ramped Stress**

MEASURE: SWEEP SETUP 95FEB02 08:38AM  
Voltage Ramp Initial/Post Spot Measurement

VARIABLE	VAR1	VAR2
UNIT	SMU1: HR	
NAME	Vg	
SWEEP MODE	SINGLE	
LI N/ LOG	LI NEAR	
START	- 5.000 V	
STOP	- 24.000 V	
STEP	- 50.0mV	
NO OF STEP	381	
COMPLIANCE	50.00mA	
POWER COMP	OFF	

\* TIMING

HOLD TIME	0.0000 s	
DELAY TIME	30.7 ms	

\* SWEEP STOP AT COMPLIANCE Status

\* CONSTANT

UNIT	SMU4: HR			
NAME	Vsub			
MODE	V			
SOURCE	0.0000 V	-----	-----	-----
COMPLIANCE	100.00mA	-----	-----	-----

SINGLE  
Select Sweep Mode with softkey or rotary knob.

SWEEP SETUP		MEASURE SETUP	OUTPUT SEQ			PREV PAGE	NEXT PAGE
-------------	--	---------------	------------	--	--	-----------	-----------

SINGLE  
DOUBLE

Figure 1-22 MEASURE: MEASURE SETUP Page for Ramped Stress

MEASURE: MEASURE SETUP 95FEB02 08:38AM  
Voltage Ramp Initial/Post Spot Measurement

* MEASUREMENT RANGE			
UNI T	NAME	RANGE	
SMU1: HR	Ig	FIXED	100uA
SMU4: HR	Isub	FIXED	100uA

ZERO CANCEL	OFF
OFF	[ 10pA]
OFF	[ 10pA]

(\*: Old data is used.)

\* INTEG TIME

	TIME	NPLC
SHORT@	640us	0.032
MED	20.0ms	1
LONG	320.ms	16

\* WAIT TIME  
0 \*( DEFAULT WAIT TIME)

FIXED  
Select Range Mode with softkey or rotary knob.

SWEEP  
SETUP

MEASURE  
SETUP

OUTPUT  
SEQ

PREV  
PAGE

NEXT  
PAGE

Figure 1-23 MEASURE: OUTPUT SEQUENCE Page for Ramped Stress

MEASURE: OUTPUT SEQUENCE 95FEB02 08:39AM  
Voltage Ramp Initial/Post Spot Measurement

* OUTPUT SEQUENCE			
	UNI T	NAME	MODE
1	SMU4: HR	Vsub	V
2	SMU1: HR	Vg	V
3	SMU2: HR		
4	SMU3: HR		
5	VSU1		
6	VSU2		

* TRIGGER SETUP	
ENABLE/ DI SABLE	ENABLE
FUNCTI ON	TRI G OUT
STEP DELAY	30.7ms
POLARI TY	POSI TIVE

SMU4: HR  
Select Output Sequence with softkey or rotary knob.

SWEEP  
SETUP

MEASURE  
SETUP

OUTPUT  
SEQ

PREV  
PAGE

NEXT  
PAGE

SMU1: HR

SMU2: HR

SMU3: HR

SMU4: HR

VSU1

VSU2

Agilent 4155B/4156B Sample Application Programs Guide Book, Edition 3

1-29

V-RAMP  
Measurement Setups

Figure 1-24 **DISPLAY: DISPLAY SETUP Page for Ramped Stress**

DI SPLAY: DI SPLAY SETUP 95FEB02 08:39AM  
Voltage Ramp Initial/Post Spot Measurement

\* DI SPLAY MODE

\* GRAPHICS

	X axis	Y1 axis	Y2 axis
NAME	Time	Ig	Vg
SCALE	LINEAR	LOG	LINEAR
MIN	0.000000 sec	-1.00pA	-5.000000 V
MAX	40.000000 sec	-1.000000000 A	-30.000000 V

\* GRID       \* LINE PARAMETER

\* DATA VARIABLES

Vbd
Qbd

GRAPHICS  
Select Display Mode with softkey or rotary knob.

Figure 1-25 **DISPLAY: ANALYSIS SETUP Page for Ramped Stress**

DI SPLAY: ANALYSIS SETUP 95FEB02 08:40AM  
Voltage Ramp Initial/Post Spot Measurement

\* LINE1: [  ]

\* LINE2: [  ]

\* MARKER: At a point where  
[ Ig ] = [ -.03 ]  
[  ]

\* Interpolate: [ OFF ]

Select Line Mode with softkey or rotary knob.

---

---

**2**

**J-RAMP**

---

Current-Ramped (J-Ramp) test is one of the Wafer Level Reliability (WLR) tests, which is used to evaluate device reliability on a wafer. This test can provide quick evaluation data for estimating the overall reliability of thin oxides, and this data can be used to improve the thin oxide manufacturing process.

With the thickness of oxide shrinking along with device geometries, creating a reliable thin oxide has become an important issue. The integrity of the thin oxide in a MOS device is a dominant factor in determining the overall reliability of a micro-circuit. The J-Ramp test can promptly give useful feedback to the manufacturing process about oxide reliability.

This operation manual covers a sample J-Ramp program running on the 4155/4156, and how to use and customize the program. The program is written in the Instrument BASIC (IBASIC), and is ready to run on the built-in IBASIC controller of the 4155/4156.

“Theory of J-Ramp Test Procedure” describes basic theory, procedure, and terminology of the J-Ramp test.

“Basic Operation” describes the J-Ramp sample program. Included are J-Ramp methodology using the 4155/4156, how to execute the sample program, and program overview.

“Customization” describes how to customize the sample program. This is very helpful because you probably need to modify the sample program to suit your test device.

“Measurement Setups” shows the 4155/4156 page settings that are stored in the setup files.

“Proof of Equations” shows how to solve equations described in “Basic Operation”.

## Theory of J-Ramp Test Procedure

This section covers Current Ramped (J-Ramp) Test procedure. Included are basic theory, procedure, and terminology of J-Ramp test.

The J-Ramp test procedure is based on the JEDEC standard No.35.

### J-Ramp Test Overview

J-Ramp test searches for the breakdown voltage ( $V_{bd}$ ), then calculates the breakdown charge ( $Q_{bd}$ ) of thin oxide capacitors, which you designed as test structures on the wafer. These results are used to evaluate the oxide integrity. The higher the  $V_{bd}$  and  $Q_{bd}$  measured by this test, the better the integrity of the oxide on wafer.

You extract these two parameters from a large amount of test structures and usually plot the cumulative breakdown/breakdown charge distribution on a probability chart. The manufacturing process should be driven so that this distribution becomes closer to the ideal shape.

In the J-Ramp test, an increasing current is forced to the oxide capacitor. This charges up the capacitor so the voltage across the capacitor increases. When the oxide layer is broken by the high electric field in the oxide, the current can flow through, so the voltage across the oxide capacitor decreases (breakdown). Breakdown voltage ( $V_{bd}$ ) is defined as the voltage at which breakdown occurs. And breakdown charge ( $Q_{bd}$ ) is the total charge forced through the oxide until breakdown occurs.

Figure 2-1 shows a simplified flowchart of J-Ramp test.

The J-Ramp test consists of three tests: initial test, ramp stress test, and post stress test.

In the initial test, an initial current  $I_0$  (typical value is 1  $\mu$ A) is forced to the oxide capacitor, then voltage across the oxide is measured to check for initial failure.

In the ramp stress test, a stepped current is applied, and the voltage across the oxide is continuously measured.

The post stress test is for confirming that failure occurred during the ramp stress test. The initial current is forced again, then the voltage across the oxide is measured.

After the tests, the test results must be analyzed and saved (data recording).

Before performing the J-Ramp test, test conditions must satisfy the following:

- Gate bias polarity is in accumulated direction. That is, negative (minus) current is applied to gate conductor for P-type bulk, and positive (plus) current is applied for N-type bulk.
- Diffusions and wells (if any) must be connected to substrate.
- Temperature is in  $25 \pm 5$  °C range.

Figure 2-1 Simplified Flow Diagram of J-Ramp Test

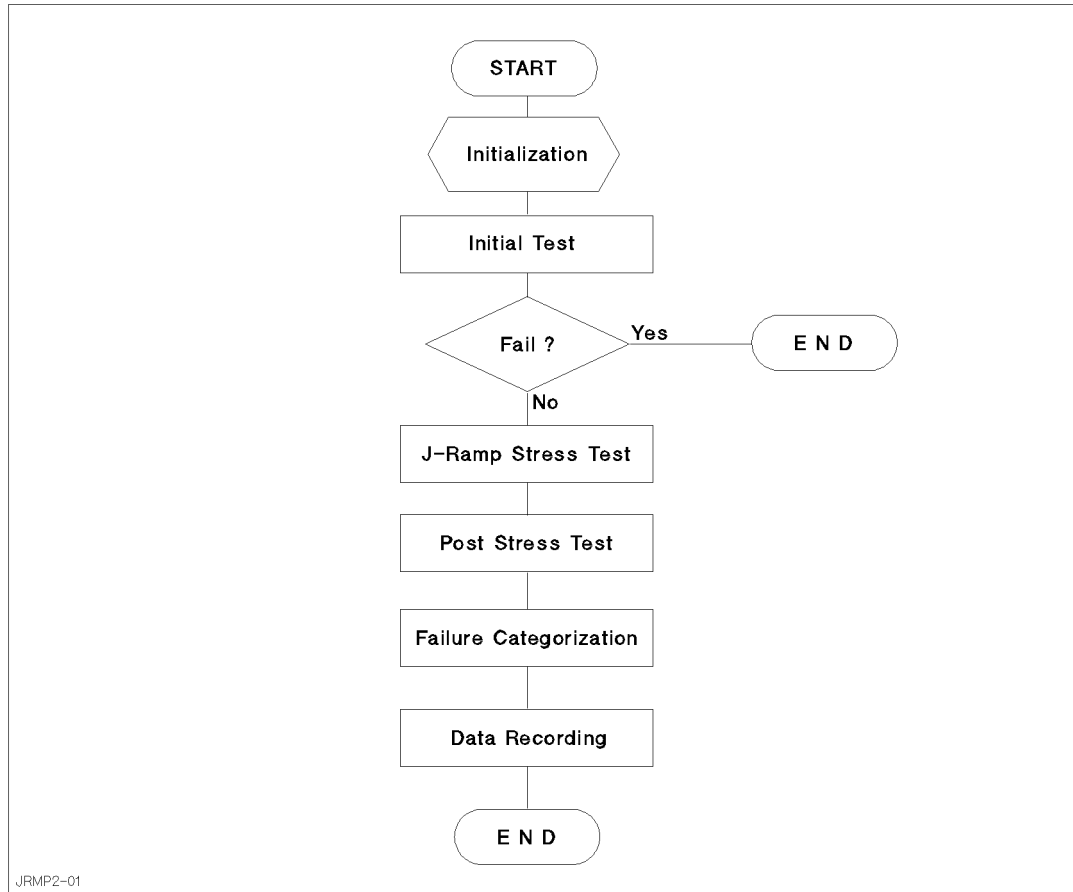

## Initial Test

Initial test is to confirm that the oxide capacitor is initially good. To do so, an initial current  $I_0$  (typical value is  $1 \mu\text{A}$ ), which is low enough not to break the oxide, is forced to the oxide capacitor, and the voltage across the oxide is measured after a certain time  $t_{initial}$ . If the measured voltage does not reach the normal operating voltage, it is categorized as **initial failure**.

If an oxide capacitor is categorized as initial failure, test should not continue for the capacitor. If the capacitor passes the initial test, the J-ramp stress test may begin immediately.

The value of  $t_{initial}$  is 50 ms or ten times the oxide time constant, whichever is greater. Initial current  $I_0$  must be large enough to charge up the capacitor within a reasonably short time  $t_{initial}$ , but must be small enough not to break the oxide.

Typically,  $10^{-6} \text{ C/cm}^2$  is the minimum breakdown current density  $q_{bd}$  that can be measured due to the system capacitance. The initial current  $I_0$  varies depending on the area of the oxide capacitor (test structure), oxide thickness, and oxide defect levels.

## J-Ramp Stress Test

A stepped current is applied to the oxide capacitor, and the voltage across the capacitor is continuously measured. Normally, applying the current to the oxide capacitor charges up the capacitor, so the voltage increases across the capacitor. When the electric field reaches a threshold, the oxide is broken, and current flows through the oxide.

Figure 2-2 shows the concept of  $V_{bd}$  and  $Q_{bd}$  for the J-ramp stress test. The forced current is increased logarithmically, and the voltage across the capacitor is measured at a constant interval. When the *measured voltage* < *previously measured voltage* × 0.85, the breakdown is considered to have occurred in the oxide. The previously measured voltage is considered to be  $V_{bd}$ , and  $Q_{bd}$  is calculated by integrating the current applied to the oxide.

If the measurement results indicate that breakdown occurred, the result of J-ramp stress test is defined as "fail".

Figure 2-2 Concept of Breakdown Voltage and Charge

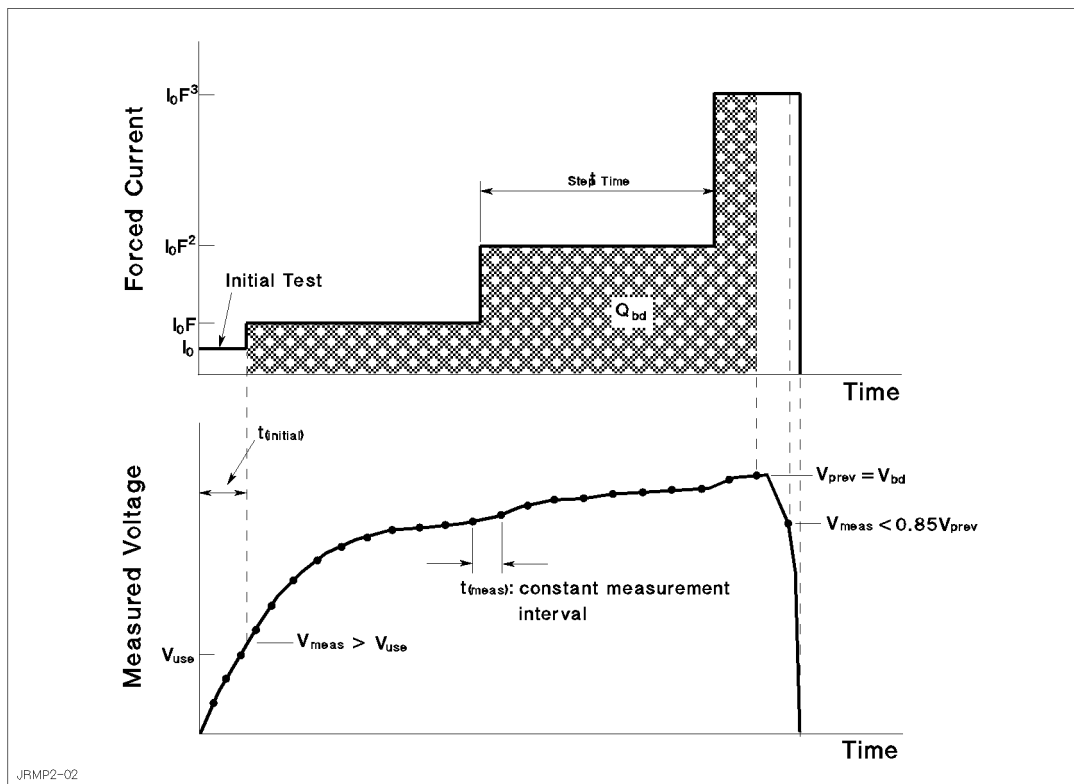

### Step Increase Factor for Forced Current

The current forced to the oxide capacitor is stepped in a logarithmic manner. The value of each step is related to the initial current  $I_0$  by the step increase factor  $F$  as shown in the following equation:

$$I_n = I_0 \times F^n$$

Where  $n = 1, 2, 3, \dots$

That is,

$$I_1 = I_0 \times F$$

$$I_2 = I_0 \times F^2$$

$$I_3 = I_0 \times F^3$$

...

$$I_n = I_0 \times F^n$$

### J-Ramp Characteristics (Conditions for Forced Current)

The forced current must satisfy the following conditions:

- Current ramp rate: 1 decade/500 ms.
- Maximum time ( $t_{meas}$ ) between voltage measurements: 50 ms or once per current step, whichever is less.
- Maximum charge density: 50 C/cm<sup>2</sup>.
- Maximum electric field (voltage compliance limit): 15 MV/cm.
- Maximum current step increase factor  $F$ :  $\sqrt{10}$ , approximately 3.2.
- Step interval time of applied current: constant.

### Indication of faulty J-ramp stress test

If either of the following situations occurs during the J-ramp stress test, the test should be aborted. This indicates that the testing was faulty.

- Accumulated charge density ( $q$ ) reaches the maximum allowed charge density. Charge density  $q$  is the accumulated charge  $Q$  divided by the oxide area  $Area$ .
- Maximum allowed electric field  $E$  is reached.

## Post Stress Test

The post stress test checks the oxide status after the J-ramp stress test. If the oxide is broken, proper J-ramp stress was applied to the oxide capacitor, and the result of post stress test is defined as "fail".

To check the oxide status, the initial current ( $I_0$ ) is applied to the oxide capacitor (same as initial test), then the voltage across the capacitor is measured. The measured voltage ( $V_{meas}$ ) indicates the following:

- If  $V_{meas} < V_{use}$  :  
The oxide was broken by the J-ramp stress test. Forced current flows through the oxide, so the voltage across the capacitor does not increase enough.
- If  $V_{meas} > V_{use}$  :  
The oxide was not broken by the J-ramp stress test. Forced current does not flow through the oxide enough, so the voltage across the capacitor increases.

One possible reason is that the testing was faulty as described in the previous section. For example, the current was not forced to the oxide due to an open circuit.

## Failure Categorization and Data Recording

According to the measurement results, the oxide status is categorized as follows:

<b>Initial Failure:</b>	Failed the initial test. Indicates initially defective oxide capacitor. Other tests should not be performed.
<b>Catastrophic Failure:</b>	Failed during J-ramp and post stress tests. Indicates that oxide capacitor was properly broken by the J-ramp stress test.
<b>Masked Catastrophic Failure:</b>	Did <i>not</i> fail during J-ramp stress test, but failed post stress test.
<b>Non-catastrophic Failure:</b>	Failed during the J-ramp stress test, but <i>not</i> post stress test.
<b>Others:</b>	Did <i>not</i> fail during J-ramp stress test, <i>and</i> did <i>not</i> fail post stress test.

The failure category is recorded for each test device. If the catastrophic failure is observed, breakdown voltage ( $V_{bd}$ ) and breakdown charge density ( $q_{bd} = Q_{bd}/Area$ ) are also recorded.

Table 2-1 shows the oxide failure categories.

**Table 2-1**

**Oxide Failure Categories**

Stress Failure Category	Initial Test	J-Ramp Stress Test	Post Stress Test
Initial	Fail	n.a.	n.a.
Catastrophic <sup>a</sup>	Pass	Fail	Fail
Masked Catastrophic	Pass	Pass	Fail
Non-catastrophic	Pass	Fail	Pass
Others	Pass	Pass	Pass

a.  $V_{bd}$  and  $q_{bd}$  are also recorded.

## Basic Operation

This section covers the following for using an 4155/4156 to perform J-Ramp Test: required equipment, required files, methodology, how to execute the sample program, and sample program overview.

### Methodology

The entire J-Ramp Test procedure can be performed by executing the JRAMP sample program on the built-in IBASIC controller of the 4155/4156.

As explained in “Theory of J-Ramp Test Procedure”, the J-ramp test consists of three measurement parts and an analysis part. Each measurement part executes three steps as follows:

1. Loads the measurement setup file into the 4155/4156 execution environment.
2. Changes some of the measurement or analysis parameters on the setup pages.
3. Executes the measurement.

The JRAMP program executes the above three steps for each test: initial test, J-ramp stress test, and post stress test. Using the measurement setups (step 1 above) loaded from a file reduces the length and complexity of the program. For details, see *Programmer's Guide*.

Measurement setups, which are loaded into the 4155/4156 execution environment, were previously developed and saved to measurement setup files on the diskette. You can easily modify the measurement setup information in fill-in-the-blank manner in the 4155/4156 execution environment. The JRAMP sample program is also saved to the diskette. You can easily modify the sample program by using the editor in the built-in IBASIC environment.

The JRAMP sample program assumes that the built-in IBASIC controller of the 4155/4156 is used, but you can also use another controller such as HP BASIC running on an external computer. To do so, you must modify the sample program for your environment. See “Customization” on how to modify the program to run on an external controller.

### Initial Test

The initial test makes sure the oxide capacitor is initially good by applying an initial current  $I_o$  ( $I_{force0}$  in the sample program), then measuring the voltage across the oxide capacitor. If the voltage does not reach the normal operating voltage, the oxide capacitor is categorized as "initial failure".

The sample program assumes that SMU1 and SMU4 are connected to the oxide capacitor as shown in Figure 2-3.

Figure 2-3 Simplified Measurement Circuit and Output Current of Initial Test

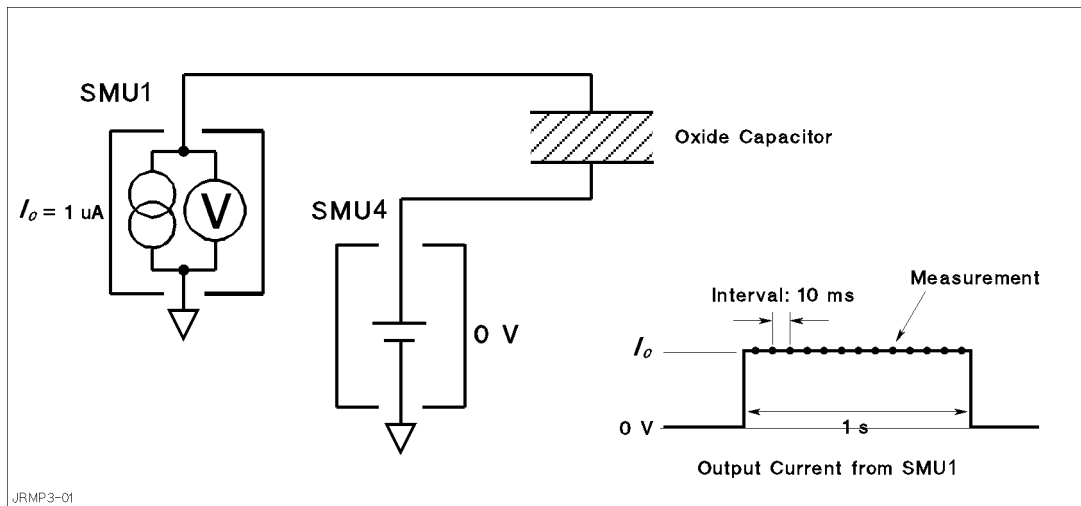

For the initial test, the sample program does as follows:

1. Sets up the 4155/4156 according to the JINIT.MES setup file, which the sample program previously loaded from the diskette into internal memory (MEM1).
2. Sets up SMU1 to constant current  $I_{force0}$  for PMOS device, or  $-I_{force0}$  for NMOS device.  $I_{force0}$  value is specified at beginning of the sample program, and reset in the MEASURE: SAMPLING SETUP page by OUTPUT statement (line 2550 of the sample program).
3. Sets the THRESHOLD value of the STOP CONDITION to  $V_{use}$  or  $-V_{use}$ , which is the normal operating voltage that was specified at beginning of the sample program.
4. Forces current  $I_{force0}$  from SMU1, and measures as set up by the JINIT.MES file described next.
5. Checks if the maximum voltage reached  $V_{use}$ . If not, the sample program aborts further testing.

The following are main points about the setup by the JINIT.MES setup file:

- On CHANNELS: CHANNEL DEFINITION page (see Figure 2-13)
  - MEASUREMENT MODE is set to SAMPLING.
  - SMU4 is set to be a constant voltage source.
  - SMU1 is set to be a constant current source.
  - $V_g$  is defined as name of voltage measured by SMU1.
- On MEASURE: SAMPLING SETUP page (see Figure 2-4)
  - Sampling mode (MODE) is set to LINEAR.
  - Sampling measurement interval (INITIAL INTERVAL) is set to 10 ms.
  - NO. OF SAMPLES is set to 100.
  - TOTAL SAMP. TIME is set to 1 second ( $t_{initial}$ ). So, for 1 second, the current  $I_{force0}$  will be forced and sampling measurements will be performed.
  - SMU4 is set to force a constant 0 V.
  - SMU1 is set to force a constant 1  $\mu$ A.
  - STOP CONDITION is enabled, NAME is set to  $V_g$ , and EVENT is set to  $|Val| > |Th|$ . Note that THRESHOLD is set to  $V_{use}$  by the sample program as described previously.

So, if the maximum  $V_g$  measured by SMU1 reaches  $V_{use}$ , the sample program next performs the J-Ramp Stress test. If not, the measurement will abort further testing.

Figure 2-4 MEASURE: SAMPLING SETUP Page for Initial Test

MEASURE: SAMPLING SETUP 95FEB02 09:20AM  
Voltage Ramp Initial/Post Spot Measurement

\*SAMPLING PARAMETER

MODE	LINEAR
INITIAL INTERVAL	10.00ms
NO. OF SAMPLES	100
TOTAL SAMP. TIME	1.00 s
HOLD TIME	0.000000 s
FILTER	ON

\*STOP CONDITION

ENABLE/DISABLE	ENABLE
ENABLE DELAY	0.0000000 s
NAME	Vg
THRESHOLD	4.0000000 V
EVENT	Val  >  Th
EVENT NO	1

\*CONSTANT

UNIT	SMU1: HR	SMU4: HR		
NAME	Ig	Vsb		
MODE	I	V		
SOURCE	-1.000uA	0.0000 V		
COMPLIANCE	40.000 V	100.00mA		

LINEAR  
Select Sampling Mode with softkey or rotary knob.

SAMPLING SETUP MEASURE SETUP OUTPUT SEQ PREV PAGE NEXT PAGE

<sup>1</sup> This value is re-specified by sample program.

## J-Ramp Stress Test

After the initial test, the sample program executes the J-ramp stress test. Logarithmic stepped current is applied to the oxide, and voltage across the oxide is measured at least once for each step.

The measurement setup for the J-ramp stress test is stored in the JRMP.MES setup file on the diskette. At the beginning of the sample program, this setup is loaded into internal memory (MEM2). Then, at the beginning of the J-ramp stress test, the sample program loads this setup into the 4155/4156.

To force proper stepped current, the sample program and JRMP.MES set the following:

- SMU channel definition (see Figure 2-5):  
SMU1 is set to current sweep mode, and SMU4 is set to force a constant 0 V.
- Constant step interval time (see Figure 2-7):  
Step interval time of output sweep current should be constant. The time can be constant by setting the *delay time* and *step delay time*. See Figure 2-7. However in the logarithmic sweep, if the sweep range extends to 1 decade or more (example; sweep range 1  $\mu\text{A}$  to 100  $\mu\text{A}$ ), the step interval time varies due to the output range changing of sweep source. This interval time error will cause the calculation error of breakdown charge ( $Q_{bd}$ ). Then the JRAMP sample program does the error correction of  $Q_{bd}$  after the measurement.
- Stepped current to be forced:  
Stepped current forced to the oxide is increased logarithmically. This stepped current is defined in the sample program.
- Measurement stop condition:  
Current sweep continues until one of three conditions is satisfied.
- Searching for breakdown point and calculating  $Q_{bd}$ :  
After the measurement, the JRAMP sample program gets the measured voltage values, and searches for the breakdown voltage ( $V_{bd}$ ). Then, calculates  $Q_{bd}$  by using the user-defined functions. Finally, the program compensates the  $Q_{bd}$  calculation error, and displays the  $Q_{bd}$  value.

**SMU channel definition.**

The sample program assumes the connection between the SMUs and the oxide capacitor as shown in Figure 2-5.

The JRMP.MES file sets the following (see Figure 2-6 and Figure 2-9):

- SMU4 is set to force a constant 0 V.
- SMU1 is set to current sweep mode.
- SMU4 is used prevent overcurrent by using its current compliance function. Compliance is set to 100 mA.

**Figure 2-5 Simplified Measurement Circuit of J-Ramp Stress Test**

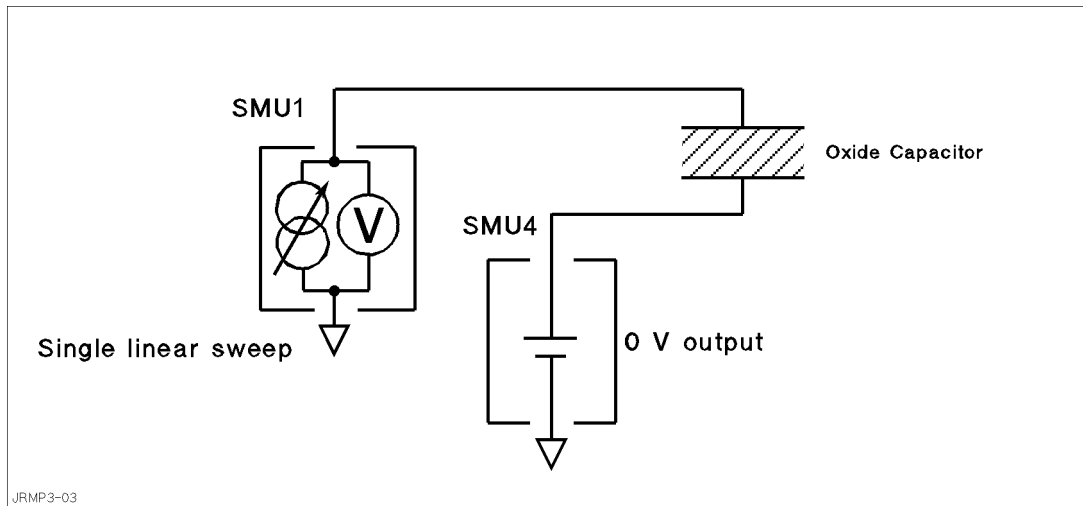

**Figure 2-6 CHANNELS: CHANNEL DEFINITION Page for J-Ramp Stress Test**

```

CHANNELS: CHANNEL DEFINITION
Voltage Ramp Initial/Post Spot Measurement

* MEASUREMENT MODE
SWEEP

* CHANNELS

```

UNIT	VNAME	I NAME	MODE	FCTN	STBY	SERIES RESISTANCE
SMU1: HR	Vg	Ig	I	VAR1		0 ohm
SMU2: HR						0 ohm
SMU3: HR						
SMU4: HR	Vsb	I sb	V	CONST		
V SU1		-----				
V SU2		-----				
V MU1		-----				
V MU2		-----				

SMU1 is sweep source (VAR1).

SMU1 and SMU 4 are connected to the oxide capacitor.

SMU4 is constant source.

### Constnt step interval.

To keep a constant step interval time for the current sweep and measurement, triggering and measurement ranging techniques are used. JRMP.MES sets the measurement ranging mode to FIXED, so the time between measurements does not vary due to measurement range changing.

JRMP.MES enables the TRIG OUT function, and the sample program calculates and sets values so that the *step interval time* becomes constant as shown in Figure 2-7. The *step interval time* (*Step\_time*) is the *delay time* (*Step\_delay\_t*) plus *step delay time* (*Step\_keep\_t*). Strictly speaking, the sample program calculates these as follows:

$$\text{Step\_time} = 0.5 \times \log_{10}(\text{Factor}) - 3.7 \text{ ms}$$

$$\text{Step\_delay\_t} = \text{Step\_time} / 2 \quad (\text{delay time})$$

$$\text{Step\_keep\_t} = \text{Step\_time} - \text{Step\_delay\_t} \quad (\text{step delay time})$$

Where,

- 3.7 ms is overhead time associated with the current output logarithmic sweep mode. So, do not set another value in this field.
- *Factor* is the step increase factor. See later in this section and “Proof of Equations” for details of this calculation.

In the logarithmic sweep, if the sweep range extends to 1 decade or more, the *step interval time* (*Step\_time*) varies due to the output range changing of sweep source. The output range changing adds the range changing time to the *step interval time*. This additional time depends on the range setting, but it is approximately 2 % of the time for 1 decade sweep. The output range changing will also cause the calculation error of *Qbd*. The JRAMP sample program can compensate this calculation error.

Figure 2-7

### Output Sweep Current for J-Ramp Stress Test

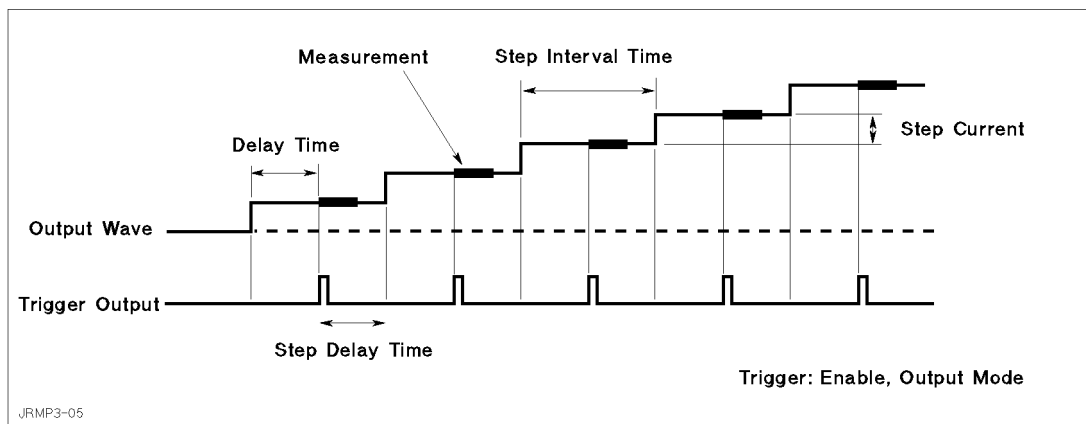
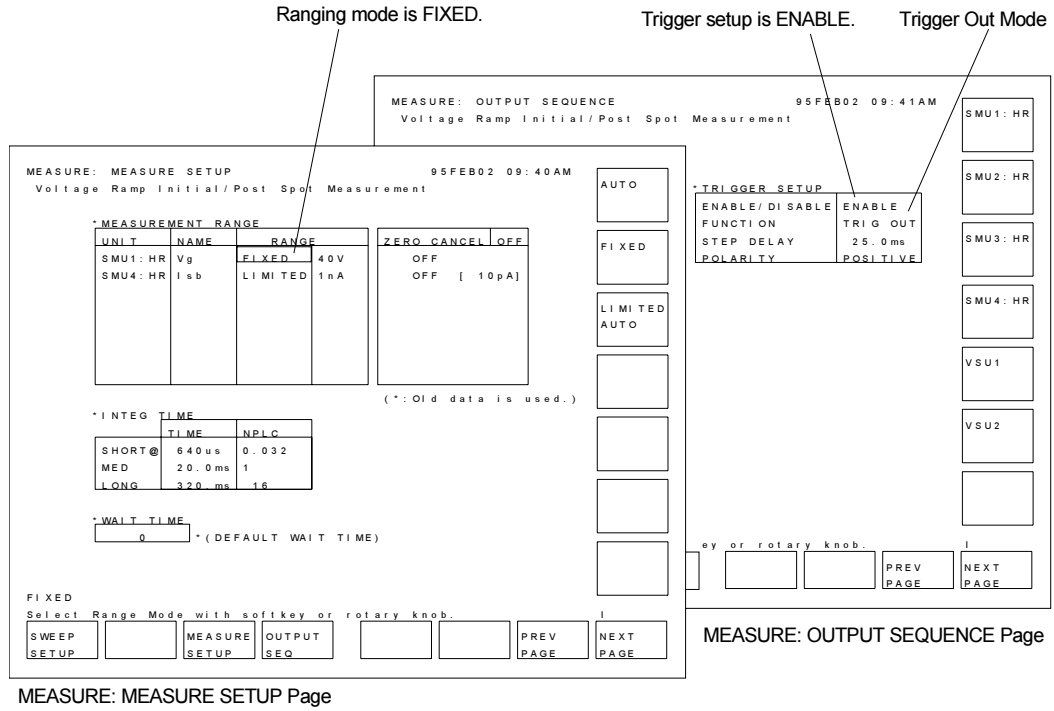

Figure 2-8

**MEASURE: MEASURE SETUP and OUTPUT SEQUENCE Pages for J-Ramp Stress Test**



### Stepped current to be forced.

The sample program sets to force to the oxide a current that increases logarithmically according to the equation  $I_n = I_0 \times F^n$ , where  $n = 1, 2, \dots n$ . See “J-Ramp Stress Test”. In the JRAMP sample program, you specify the start current (`Iforce0` on line 1800) and step increase factor  $F$  (`Factor` on line 1890), then the step interval time (`Step_time` on line 1900) and stop current (`Istop` on line 4560) are calculated. For NMOS devices, the ramp test subprogram actually sets the opposite polarity for these values by using the `Tp` variable (lines 2020 and 2030).

`Iforce0` is normally 1  $\mu\text{A}$ , as mentioned in the “Theory of J-Ramp Test Procedure”. Three values ( $10^{1/10}$ ,  $10^{1/25}$ , and  $10^{1/50}$ ) are possible for step factor  $F$  (`Factor`) of the 4155/4156 because you can use 10, 25, or 50 steps per decade for the logarithmic sweep.

The step interval time  $T_s$  (`Step_time` in program) of each step depends on the number of steps per decade, and must satisfy the condition that the ramp rate is 1 decade/500 ms. So, if  $N$  is the number of steps per decade, then  $T_s = 0.5/N$ . The following is the relationship of  $T_s$  to the step increase factor  $F$ :

$$T_s = 0.5 \times \log_{10} F$$

The current is stepped logarithmically until the charge density reaches the maximum allowed value, which is normally 50 C/cm<sup>2</sup>, as follows:

$$\int_0^n I(t) dt = \int_0^n I_0 \cdot F^n \cdot T_s \cdot dn = q_{max} \cdot Area$$

Where,  $I(t) = I_0 \times F^n$ ,  $t = n \times T_s$  (time),  $n$  is step number,  $T_s$  is the step interval time,  $q_{max}$  is the maximum allowed charge density, and  $Area$  is the area of the oxide capacitor.

If you solve for  $n$  in the equation above, you get the following result:

$$n = \frac{1}{\log_{10} F} \cdot \log_{10} \left( \frac{\log_{10} F \cdot q_{max} \cdot Area}{I_0 \cdot T_s} + 1 \right)$$

So, the current will be stepped  $n$  times to reach the maximum charge density, and the value of the current (`Istop`) at that step will be as follows:

$$I_{stop} = I_0 \cdot F^n$$

So, the sample program calculates and sets  $T_s$  (`Step_time`) and `Istop` as described above.

For details about solving all the above equations above, see “Proof of Equations”.

**Measurement stop condition.**

**NOTE**

JEDEC Standard No. 35 specifies that the current sweep should abort when breakdown occurs, but the JRAMP sample program continues the current sweep until one of the following three conditions is satisfied:

- Current sweep setting reaches current stop ( $I_{stop}$ ), which sample program calculates according to the maximum allowed charge density.
- SMU4 (which is set to force 0 V) reaches current compliance, which is set to 100 mA by the measurement setup file JRMP.MES.
- SMU1 (which is current sweep source) reaches voltage compliance ( $V_{gcomp}$ ), which the sample program calculates as  $Max\_e * T_{ox}$ , where  $Max\_e$  is the maximum allowed electric field, and  $T_{ox}$  is the oxide thickness.

When the voltage across the oxide reaches the voltage compliance setting, the measurement must stop and current sweep must be aborted. So, SWEEP STOP AT COMPLIANCE must be set as shown in Figure 2-9.

**Figure 2-9**

**MEASURE: SWEEP SETUP Page for J-Ramp Stress Test**

MEASURE: SWEEP SETUP 94 DEC 29 09:29 AM

* VARIABLE	VAR1	VAR2
UNIT	SMU1: HR	
NAME	I <sub>g</sub>	
SWEEP MODE	SINGLE	
LIN/LOG	LOG 10	
START	1.000 uA	
STOP	100.00 uA	
STEP	-----	
NO OF STEP	21	
COMPLIANCE	30.000 V	
POWER COMP	OFF	

Sweep aborts at COMPLIANCE.

* TIMING	
HOLD TIME	0.0000 s
DELAY TIME	25.0ms

\* SWEEP **STOP AT COMPLIANCE** Status

* CONSTANT			
UNIT	SMU4: HR		
NAME	V <sub>sb</sub>		
MODE	V		
SOURCE	0.0000 V	-----	-----
COMPLIANCE	100.00 mA	-----	-----

SINGLE

Select Sweep Mode with softkey or rotary knob.

SWEEP SETUP		MEASURE SETUP	OUTPUT SEQ			PREV PAGE	NEXT PAGE
-------------	--	---------------	------------	--	--	-----------	-----------

### Searching for breakdown point and calculating $Q_{bd}$ .

The sample program searches for the breakdown point as follows:

When a *measured voltage* < *previous measured voltage* × 0.85, the previous measured voltage is defined as the breakdown voltage ( $V_{bd}$ ).

To search for  $V_{bd}$ , the sample program stores all the measured voltage values in array variable  $V_g$ , then searches for the first TRUE case of the following, then sets  $V_{bd}$  as follows:

1. If  $V_g(2) < V_g(1) * 0.85$ , then  $V_{bd} = V_g(1)$ .
2. If  $V_g(3) < V_g(2) * 0.85$ , then  $V_{bd} = V_g(2)$ .
3. If  $V_g(4) < V_g(3) * 0.85$ , then  $V_{bd} = V_g(3)$ .

.....

99. If  $V_g(100) < V_g(99) * 0.85$ , then  $V_{bd} = V_g(99)$ .

IBASIC programming can easily realize this algorithm.

After finding the breakdown point, the sample program performs analysis on the measured curve to get  $Q_{bd}$  as follows:

1. Displays marker on the curve.
2. Moves the marker to the breakdown point.
3. Calculates  $Q_{bd}$  by using a user function.
4. Saves value of  $Q_{bd}$ .

The user-defined function calculates  $Q_{bd}$  as follows:

$$Q_{bd} = \int_{T_{start}}^{t_{bd}} I_g(t) dt = \frac{1}{2} \sum_{i=2}^n (I_{g_i} + I_{g_{i-1}}) \cdot (T_i - T_{i-1})$$

Where,  $n$  is step number when the breakdown occurs.

The JRMP.MES setup file defines the user functions on the CHANNELS: USER FUNCTION DEFINITION page (see Figure 2-21) as follows:

Table 2-2

#### User Functions for Ramp Stress Test

Name	Units	Definition
Time	sec	0.05 * @INDEX <sup>a</sup>
Vbd	V	@MY2
Qbdo	C	INTEG(Ig,Time)
Qbd	C	0 <sup>b</sup>

- a. This is a temporary definition. Time is redefined by line 2940 of the sample program.
- b. This is a temporary value.  $Q_{bd}$  value is entered by line 3590 of the sample program.

## Post Stress Test

Post stress test checks the oxide status after the ramp stress test.

The methodology of the post stress test is the same as for initial test. Initial current ( $I_{force0}$ ) is applied to the oxide, then the voltage across the oxide capacitor is measured.

For the measurement circuit, connections, and measurement setups, see “Initial Test”.

## Failure Categorization

Table 2-3 shows the oxide failure categories that are determined by the sample program. The failure category is displayed for each device, and  $V_{bd}$ ,  $Q_{bd}$ , and  $q_{bd}$  are also displayed.

The measured data and measurement settings are saved in a file.

Table 2-3

**Oxide Failure Categories**

Category	Initial Test	Ramp Stress Test	Post Stress Test
Initial	$V_{meas} < V_{use}$	n.a.	n.a.
Catastrophic	$V_{meas} \geq V_{use}$	$V_{meas} < 0.85 \times V_{prev}$ occurs.	$V_{meas} < V_{use}$
Masked Catastrophic	$V_{meas} \geq V_{use}$	$V_{meas} < 0.85 \times V_{prev}$ does not occur.	$V_{meas} < V_{use}$
Non-catastrophic	$V_{meas} \geq V_{use}$	$V_{meas} < 0.85 \times V_{prev}$ occurs.	$V_{meas} \geq V_{use}$
Other	$V_{meas} \geq V_{use}$	$V_{meas} < 0.85 \times V_{prev}$ does not occur.	$V_{meas} \geq V_{use}$

## Required Equipment

The following equipment is required to use the J-Ramp sample program:

- 4155 or 4156 Semiconductor Parameter Analyzer
- Two triaxial cables
- Probe station
- This operation manual
- Diskette that contains sample program file and two setup files. See below.

## Program Files Required

The following files are used for the J-Ramp test:

<b>JRAMP</b>	J-Ramp sample program. This is an IBASIC program file saved in ASCII format.
<b>JINIT.MES</b>	Measurement setup file for initial and post stress test.
<b>JRMP.MES</b>	Measurement setup file for J-ramp stress test.

## Executing the JRAMP Program

Before executing the program, you may need to customize the program to suit your test device. See “Customization”.

This procedure describes how to execute the sample program.

1. Display the SYSTEM: MISCELLANEOUS screen, and set the REMOTE CONTROL COMMAND SET field to 4155/4156.
2. Display the All IBASIC screen by pressing the front-panel **Display** key twice.
3. Insert a diskette containing the JRAMP program and JRMP.MES file into the built-in 3.5 inch flexible disk drive.
4. Get the JRAMP sample program as follows:
  - a. Select the GET "" softkey.
  - b. Enter JRAMP as shown below.

```
GET"JRAMP"
```
  - c. Press the front-panel **Enter** key.
5. (Optional) Edit the program, and change the measurement conditions. See Table 2-4.
6. Connect test device to the 4155/4156. See Figure 2-3.
7. Press the front-panel **Run** key to execute the program.

Measurement results similar to the Figure 2-10 will be displayed on the GRAPHICS page of the 4155/4156.

Table 2-4 JRAMP Sample Program Setup Parameters

Parameter	Line No.	Variable Name	Default Value
Device Type (NMOS or PMOS)	1790	Type\$ <sup>a</sup>	NMOS
Initial current or sweep start current (A)	1800	Iforce0	1.E-6
Normal operating voltage for the device (V) (threshold value used for Initial Test/Post Test)	1810	Vuse	5
Type of SMU used for current sweep source (1: HRSMU, 0: MPSMU or HPSMU)	1820	Smu_type <sup>b</sup>	1
Ramp step increase factor 10 <sup>1/10</sup> , 10 <sup>1/25</sup> , or 10 <sup>1/50</sup>	1890	Factor	10 <sup>1/10</sup>
Maximum charge (C/cm <sup>2</sup> )	1940	Max_q	50
Maximum electric field (V/cm)	1950	Max_e	15*1.E+6
Thickness of oxide (cm)	1970	Tox	130*1.E-8
Area of oxide capacitor (cm <sup>2</sup> )	1980	Area	0.001

- If type is NMOS, opposite polarity values for some of the values are actually used later in the program by using the T<sub>P</sub> parameter, which is set to -1 in line 2030.
- If you use the 4155, or MPSMU in the 41501 Expander, change the value to 0. If you use the HPSMU in the 41501, use the JRAMP1 sample program. See “When SMU Lacks Power to Break Oxide”.

Figure 2-10 An Example of Measurement Results

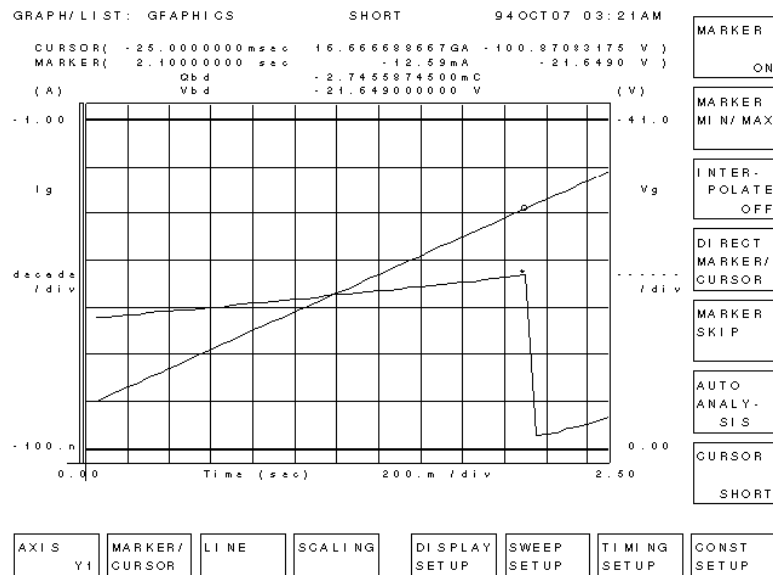

## Flowchart of Sample JRAMP Program

Figure 2-11 shows flowchart of sample JRAMP program and corresponding subprogram names.

Figure 2-11 Flowchart of Sample JRAMP Program

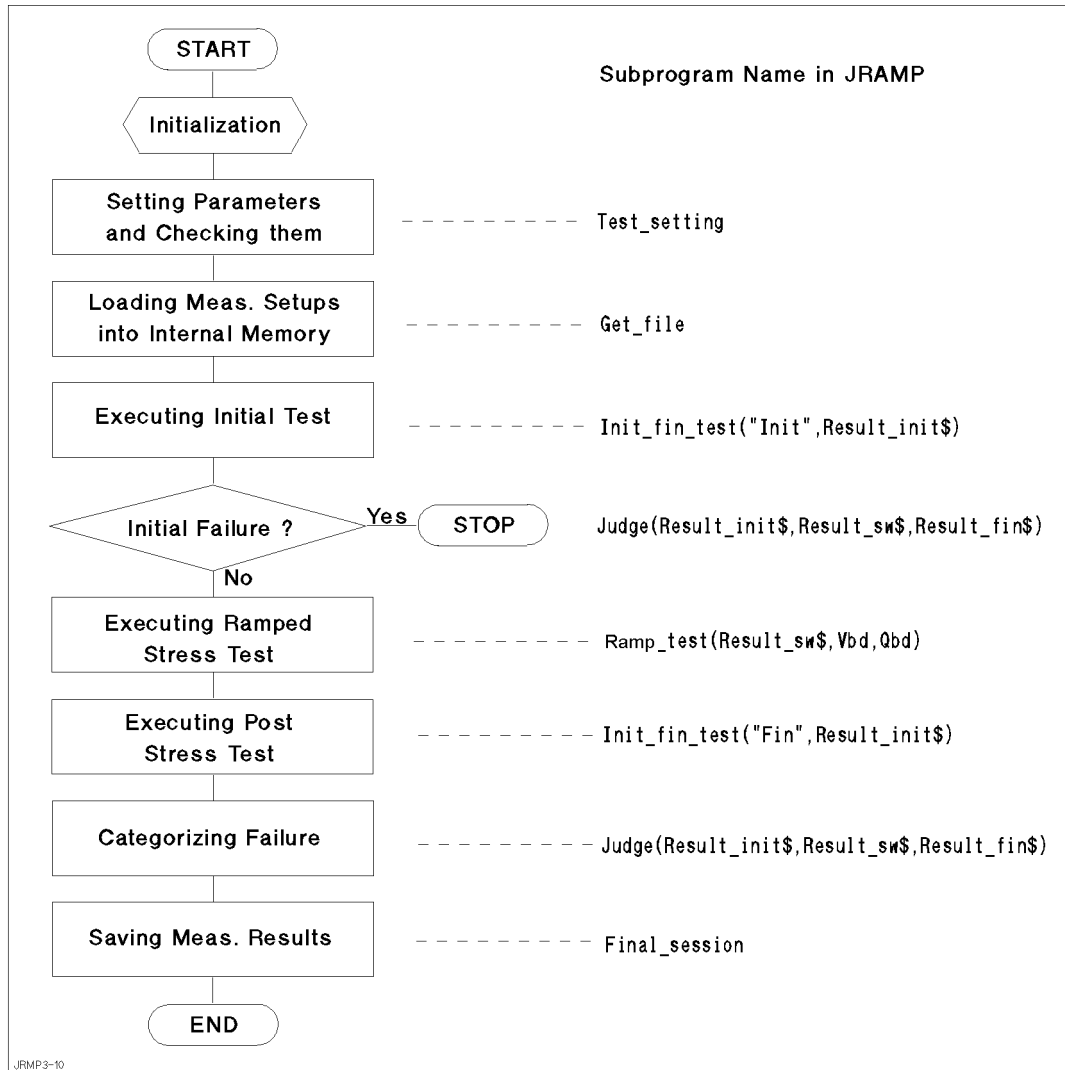

The following provides a brief description for each subprogram.

<b>Test_setting</b>	Specifies and checks the parameter values. These are values that the program will set directly instead of some of the setup file values. This subprogram calls the <code>Calc_istop</code> subprogram to calculate the sweep stop current value.
<b>Get_file</b>	Loads measurement setup files from the diskette into internal memory: initial/post measurement setup into MEM1, and sweep measurement setup into MEM2. Having the measurement setups in internal memory reduces the measurement time.
<b>Init_fin_test</b>	Executes initial test or post stress test. First parameter specifies the test: <code>Init</code> is for initial test, and <code>Fin</code> is for post stress test. The measurement results are returned to the second parameter.
<b>Judge</b>	Categorizes failure according to measurement results of initial, ramped stress, and post stress tests. If the failure is initial failure, this subprogram aborts the program.
<b>Ramp_test</b>	Executes sweep measurement for ramped stress test. After the measurement, compensates the $Qbd$ value using the <code>FNCompen</code> function, and displays $Vbd$ , $Qbd$ , and $qbd$ values. The measurement result data is temporarily stored in internal memory (MEM3).
<b>Save_data</b>	Saves measurement result data (in MEM3) to a file on the diskette.
<b>Calc_istop</b>	Calculates the sweep stop current value from the start current ( <code>Iforce0</code> ) and ramp step increase factor ( <code>Factor</code> ).
<b>FNCompen</b>	Compensates the $Qbd$ calculation error caused by the sweep source output range changing.

---

## Customization

This section describes how to customize the sample program to suit your test device.

### Using an External Computer

This sample program (JRAMP) is assumed to run on the Instrument BASIC that is built into the 4155/4156. The 4155/4156 is used as both the measurement instrument and the controller running IBASIC, so JRAMP sets device selector 800. On the following three lines, the 4155/4156 is assigned and interrupt from it is enabled as follows:

```
1450 ASSIGN @Hp4155 TO 800
      :
1530 ON INTR 8 CALL Err_check
1540 ENABLE INTR 8;2
```

If you use an external controller (that can run HP BASIC environment) to control the 4155/4156, you need to modify a few lines of the sample program. For example, if you use HP BASIC/WS on an HP 9000 Series 300 computer, you only need to modify lines the above three lines as follows:

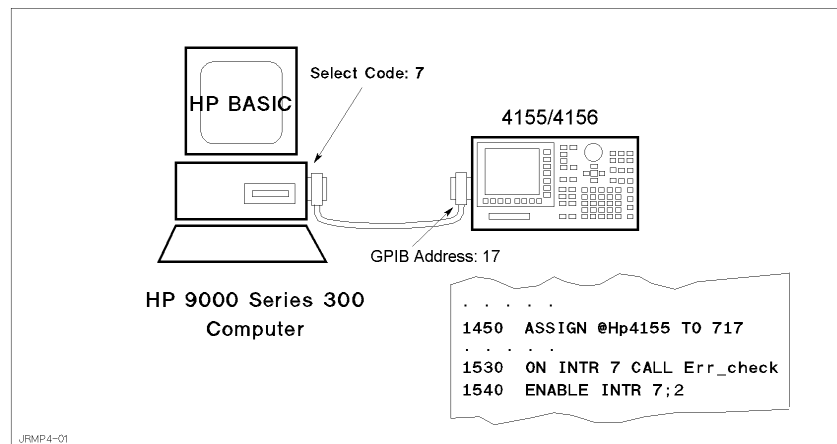

In this case, the 4155/4156 has GPIB address 17 and is not used as the system controller, and is connected to the built-in GPIB of the HP 9000 series 300 controller with a GPIB cable. Use the following procedure to set the GPIB address and system mode:

1. Turn on your 4155/4156.
2. Press the front-panel **System** key.
3. Select the MISCELLANEOUS softkey.
4. Move the field pointer to the "415x is " field, then select NOT CONTROLLER softkey.
5. Move the field pointer to the "415x" field in the GPIB ADDRESS area, then enter: 17  
**Enter**.

SYSTEM: MISCELLANEOUS 99DEC10 04:42PM

\* 4156B is

System Mode:

\* POWER LINE FREQUENCY

\* GPIB ADDRESS

HARD COPY

GPIB Address:

\* REMOTE CONTROL

COMMAND SET

\* 4156B NETWORK SETUP

HOST NAME

IP ADDRESS

USER ID

GROUP ID

\* NETWORK PRINTER SETUP

PRINTER

IP ADDRESS

TEXT OUT

GRAPH OUT

SERVER TYPE

\* CLOCK

Y	M	D	H	M
1999	12	10	16	42

\* SYSTEM SETUP

BEEP	ON
SCREEN SAVE	30 min
LP TIMEOUT	300 sec

\* NETWORK DRIVE SETUP

LABEL

IP ADDRESS

DIRECTORY

NOT SYSTEM CONTROLLER

Select System Control Mode with softkey or rotary knob.

FILER  CONFIG  PRINT  SETUP

CONTROLLER

## Specifying Setup File to Load

Two setup files are used to set up the 4155/4156 for the J-Ramp test: one is used for initial and post stress tests, and the other is for ramp stress test.

Filename of these setups are defined on the following lines:

```
1740 Init_file$="JINIT.MES" !Init/Post Measurement Setup File Name
1750 Sweep_file$="JRMP.MES" !Ramp Setup File Name
```

If you want to use other setup files, store the setup files on the diskette, then modify the filenames on the lines above.

## File for Saving Measurement Results

The following lines specify the filename for the measurement results file. The filename starts with "D", then *HHMMSS*, then ends with ".DAT". Where *HH* is hour, *MM* is minute, and *S* is second (tens digit only).

```
1760 Save_file$=TIME$(TIMEDATE) !File Name for saving measurement
results
1770 Save_file$="D"&Save_file$[1,2]&Save_file$[4,5]&Save_file$[7,7]&
".DAT"
```

The following line commands the 4155/4156 to create the specified file on the diskette, then stores the result data in the file.

```
4120 OUTPUT @Hp4155;" :MMEM:STOR:TRACDEF,'"&Save_file$&'",'DISK'"
```

For example, "D09344.DAT" file that contains measurement data is created on the diskette. This filename means the "data file created at 9:34 4x seconds."

To change to your desired filename, you only need to edit line 1770.

## Setting up Input Parameters

Input parameter values are specified on the following lines. These are values that the sample program will set directly instead of using some of the setup file values. You can easily modify the values by editing these program lines.

```

1790 Type$="NMOS"      !Dev type NMOS - P bulk, PMOS - N bulk
1800 Iforce0=1.E-6    !Initial current (A)
1810 Vuse=5           !Vuse (V) (Reference for Init/Post test)
1820 Smu_type=1       !SMU type used
1830                 !0:MP/HPSMU
1840                 !1:HRSMU
1850 !-----
1860 !Allowable current factor:
1870 !10^(1/10), 10^(1/25), 10^(1/50)
1880 !-----
1890 Factor=10^(1/10) !Current factor
1900 Step_time=.5/(1/LGT(Factor))-0.0037 !Ramp step time
1910 Step_delay_t=Step_time/2           !Step Delay time
1920 Step_keep_t=Step_time-Step_delay_t !Step keep time
1930 !
1940 Max_q=50           !Maximum charge (C/cm^2)
1950 Max_e=15*1.E+6    !Maximum Field (V/cm)
1960 !
1970 Tox=130*1.E-8     !Oxide Thickness (cm)
1980 Area=.001         !Area of oxide capacitor (cm^2)
1990 Calc_istop        !Calculate Istop (A)
2000 Vgcomp=Max_e*Tox !Vg compliance (V)
2010 Igcomp=.1         !Ig compliance (A)

```

Parameter	Default	Description
Type\$ <sup>a</sup>	NMOS	Bulk type: NMOS is for P bulk and PMOS is for N bulk
Iforce0	1 (μA)	Initial current
Vuse	5 (V)	Normal operating voltage for the device
Smu_type <sup>b</sup>	1	Type of SMU used for current sweep source (1: HRSMU, 0: MPSMU or HPSMU)
Factor	10 <sup>1/10</sup>	Ramp step increase factor <i>F</i> (10 <sup>1/10</sup> , 10 <sup>1/25</sup> , or 10 <sup>1/50</sup> )
Max_q	50 (C/cm <sup>2</sup> )	Maximum charge density
Max_e	15 (MV/cm)	Maximum electric field
Tox	1.30*10 <sup>-6</sup> (cm)	Thickness of oxide
Area	0.001 (cm <sup>2</sup> )	Area of oxide capacitor

- a. If type is NMOS, opposite polarity values for some of the values are actually used later in the program by using the  $T_p$  parameter, which is set to -1 in line 2030.
- b. If you use the 4155, or MPSMU in the 41501 Expander, change the value to 0. If you use the HPSMU in the 41501, use the JRAMP1 sample program. See “When SMU Lacks Power to Break Oxide”.

## When SMU Lacks Power to Break Oxide

You may encounter that the oxide does not break using MPSMU or HRSMU. Because voltage enough to break the oxide is not forced when relatively high current is forced. MPSMU or HRSMU can force maximum 20 V with the range of 40 mA through 100 mA.

To solve this problem, you can use HPSMU which is in the 41501 Expander. The HPSMU can force maximum 100 V with the range of 50 mA through 125 mA.

The following program and setup files assume to perform J-Ramp Test using an HPSMU and an SMU. Figure 2-12 shows the connections between SMUs and a DUT.

**JRAMP1** J-Ramp sample program with HPSMU. This is an IBASIC program file saved in ASCII format.

**JINIT1.MES** Measurement setup file for initial and post stress test with HPSMU.

**JRMP1.MES** Measurement setup file for J-ramp stress test with HPSMU.

Note that you may need to customize the JRAMP1 program and JINIT1.MES and JRMP1.MES setup files for your application before execution.

**Figure 2-12** Simplified Measurement Circuit of J-Ramp Test With HPSMU

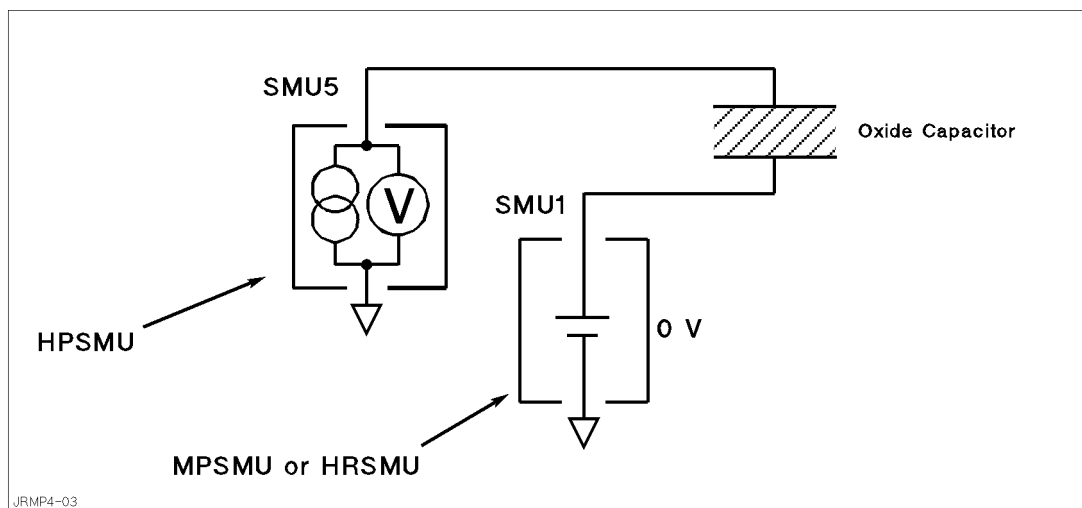

## **Measurement Setups**

This section covers the measurement setups that are stored in the JINIT.MES and JRMP.MES files.

### **Setups for Initial and Post Stress Tests**

The measurement setups stored in JINIT.MES are used for the initial and post stress tests. The setups of each page are shown in Figure 2-13 to Figure 2-19.

### **Setups for Ramped Stress Test**

The measurement setups stored in JRMP.MES are used for the ramped stress test. The setups of each page are shown in Figure 2-20 to Figure 2-26.

Figure 2-13

**CHANNELS: CHANNEL DEFINITION Page for Initial/Post Stress**

CHANNELS: CHANNEL DEFINITION 95FEB02 09:19AM  
Voltage Ramp Initial/Post Spot Measurement

\* MEASUREMENT MODE

SAMPLING

\* CHANNELS

UNIT	MEASURE				STBY	SERIES RESISTANCE
	VNAME	I NAME	MODE	FCTN		
SMU1: HR	Vg	I g	I	CONST		0 ohm
SMU2: HR						0 ohm
SMU3: HR						
SMU4: HR	Vsb	I sb	V	CONST		
VSU1		-----				
VSU2		-----				
VMU1		-----			----	
VMU2		-----			----	

SWEEP

SAMPLING

DEFAULT  
MEASURE  
SETUP

MEM1 M  
B-Tr  
VCE-IC

MEM2 M  
FET  
VDS-ID

MEM3 M  
FET  
VGS-ID

MEM4 M  
DIODE  
VF-IF

SAMPLING

Select Measurement Mode with softkey or rotary knob.

CHANNEL DEF USER FCTN USER VAR [ ] [ ] [ ] [ ] NEXT PAGE

Figure 2-14

**CHANNELS: USER FUNCTION DEFINITION Page for Initial/Post Stress**

CHANNELS: USER FUNCTION DEFINITION 95FEB02 09:19AM  
Voltage Ramp Initial/Post Spot Measurement

\* USER FUNCTION

NAME	UNIT	DEFINITION
Vm	V	@MY1

[ ]

[ ]

[ ]

[ ]

[ ]

[ ]

DELETE  
ROW

Vm

Enter User Function Name. (max 6 chars.)

CHANNEL DEF USER FCTN USER VAR [ ] [ ] [ ] [ ] PREV PAGE NEXT PAGE

Figure 2-15 MEASURE: SAMPLING SETUP Page for Initial/Post Stress

MEASURE: SAMPLING SETUP 95FEB02 09:20AM  
Voltage Ramp Initial/Post Spot Measurement

* SAMPLING PARAMETER		* STOP CONDITION	
MODE	LI NEAR	ENABLE/DI SABLE	ENABLE
INITIAL INTERVAL	10.00ms	ENABLE DELAY	0.0000000 s
NO. OF SAMPLES	100	NAME	Vg
TOTAL SAMP. TIME	1.00 s	THRESHOLD	4.0000000 V
		EVENT	Val  >  Th
		EVENT NO.	1
HOLD TIME	0.000000 s		
FILTER	ON		

* CONSTANT			
UNIT	SMU1: HR	SMU4: HR	
NAME	Ig	Vsb	
MODE	I	V	
SOURCE	-1.000uA	0.0000 V	-----
COMPLIANCE	40.000 V	100.00mA	-----

LI NEAR  
Select Sampling Mode with softkey or rotary knob.

SAMPLNG SETUP		MEASURE SETUP	OUTPUT SEQ			PREV PAGE	NEXT PAGE
---------------	--	---------------	------------	--	--	-----------	-----------

Figure 2-16 MEASURE: MEASURE SETUP Page for Initial/Post Stress

MEASURE: MEASURE SETUP 95FEB02 09:20AM  
Voltage Ramp Initial/Post Spot Measurement

* MEASUREMENT RANGE			
UNIT	NAME	RANGE	
SMU1: HR	Vg	AUTO	-----
SMU4: HR	I sb	LI MI TED	1nA

ZERO CANCEL	OFF
OFF	
OFF	[ 10pA]

(\*: Old data is used.)

* INTEG TIME		
	TI ME	NPLC
SHORT @	640us	0.032
MED	20.0ms	1
LONG	320.ms	16

\* WAIT TIME  
1 \*( DEFAULT WAIT TIME)

AUTO  
Select Range Mode with softkey or rotary knob.

SAMPLNG SETUP		MEASURE SETUP	OUTPUT SEQ			PREV PAGE	NEXT PAGE
---------------	--	---------------	------------	--	--	-----------	-----------

Figure 2-17

**MEASURE: OUTPUT SEQUENCE Page for Initial/Post Stress**

MEASURE: OUTPUT SEQUENCE 95FEB02 09:21AM  
Voltage Ramp Initial/Post Spot Measurement

* OUTPUT SEQUENCE				* TRIGGER SETUP	
	UNI T	NAME	MODE	ENABLE/ DI SABLE	DI SABLE
1	SMU4: HR	Vsb	V	FUNCTI ON	TRI G OUT
2	SMU1: HR	Ig	I	STEP DELAY	0.000 s
3	SMU2: HR			POLARI TY	POSITI VE
4	SMU3: HR				
5	VSU1				
6	VSU2				

\* OUTPUT SEQUENCE MODE OF SAMPLING  
SIMULTANEOUS

SMU4: HR  
Select Output Sequence with softkey or rotary knob.

SAMPLNG SETUP		MEASURE SETUP	OUTPUT SEQ			PREV PAGE	NEXT PAGE
---------------	--	---------------	------------	--	--	-----------	-----------

Figure 2-18

**DISPLAY: DISPLAY SETUP Page for Initial/Post Stress**

DI SPLAY: DI SPLAY SETUP 95FEB02 09:21AM  
Voltage Ramp Initial/Post Spot Measurement

\* DI SPLAY MODE  
GRAPHI CS

\* GRAPHI CS

	Xaxis	Y1axis	Y2axis
NAME	@TIME	Vg	
SCALE	LI NEAR	LI NEAR	
MI N	0.000000000 s	-110.000 mV	
MAX	1.00000 s	-100.000 mV	

\* GRI D ON      \* LINE PARAMETER ON

\* DATA VARIABLES  
Vm

GRAPHI CS  
Select Di splay Mode with softkey or rotary knob.

DI SPLAY SETUP	ANLYSIS SETUP					PREV PAGE	NEXT PAGE
----------------	---------------	--	--	--	--	-----------	-----------

Figure 2-19 **DISPLAY: ANALYSIS SETUP Page for Initial/Post Stress**

DI SPLAY: ANALYSIS SETUP 95FEB02 09:21AM  
Voltage Ramp Initial/Post Spot Measurement

\*LINE1: [ ]

\*LINE2: [ ]

\*MARKER: At a point where  
[ Vg ] = [ MAX(Vg) ]  
[ ]

\*Interpolate: [ OFF]

Select Line Mode with softkey or rotary knob.

I

DI SPLAY SETUP	ANLYSIS SETUP					PREV PAGE	NEXT PAGE
-------------------	------------------	--	--	--	--	--------------	--------------

NORMAL

GRAD

TANGENT

REGRES-  
SION

DI SABLE

Figure 2-20 **CHANNELS: CHANNEL DEFINITION Page for Ramped Stress**

CHANNELS: CHANNEL DEFINITION 98OCT29 01:34PM  
Voltage Ramp Initial/Post Spot Measurement

\*MEASUREMENT MODE  
SWEEP

\*CHANNELS

MEASURE					STBY	SERIES RESISTANCE
UNIT	VNAME	I NAME	MODE	FCTN		
SMU1: HR	Vg	I g	I	VAR1		0 ohm
SMU2: HR						0 ohm
SMU3: HR						
SMU4: HR	Vsb	I sb	V	CONST		
VSU1		-----				
VSU2		-----				
VMU1		-----				
VMU2		-----				

SWEEP

Select Measurement Mode with softkey or rotary knob. B

CHANNEL DEF	USER FCTN	USER VAR					NEXT PAGE
----------------	--------------	-------------	--	--	--	--	--------------

SWEEP

SAM-  
PLING

DEFAULT  
MEASURE  
SETUP

MEM1 M  
B-Tr  
VCE- I C

MEM2 M  
FET  
VDS- I D

MEM3 M  
FET  
VGS- I D

MEM4 M  
DIODE  
VF- I F



Figure 2-23 MEASURE: MEASURE SETUP Page for Ramped Stress

MEASURE: MEASURE SETUP 98OCT30 11:19AM  
Voltage Ramp Initial/Post Spot Measurement

AUTO  
 FIXED  
 LIMITED  
 AUTO

\* MEASUREMENT RANGE

UNI T	NAME	RANGE		ZERO CANCEL	OFF
SMU1: HR	Vg	FIXED	40V	OFF	
SMU4: HR	I <sub>sb</sub>	LIMITED	1nA	OFF	[ 10pA]

(\*: Old data is used.)

\* INTEGRATION TIME

	TIME	NPLC
SHORT@	640us	0.0384
MED	16.7ms	1
LONG	266*ms	16

\* WAIT TIME

\*(DEFAULT WAIT TIME)

FIXED  
Select Range Mode with softkey or rotary knob.

Figure 2-24 MEASURE: OUTPUT SEQUENCE Page for Ramped Stress

MEASURE: OUTPUT SEQUENCE 95FEB02 09:41AM  
Voltage Ramp Initial/Post Spot Measurement

SMU1: HR  
 SMU2: HR  
 SMU3: HR  
 SMU4: HR  
 VSU1  
 VSU2

\* OUTPUT SEQUENCE

	UNI T	NAME	MODE
1	SMU4: HR	V <sub>sb</sub>	V
2	SMU1: HR	I <sub>g</sub>	I
3	SMU2: HR		
4	SMU3: HR		
5	VSU1		
6	VSU2		

\* TRIGGER SETUP

ENABLE/ DI SABLE FUNCTI ON	ENABLE TRI G OUT
STEP DELAY	25.0ms
POLARI TY	POSITI VE

SMU4: HR  
Select Output Sequence with softkey or rotary knob.

Figure 2-25

**DISPLAY: DISPLAY SETUP Page for Ramped Stress**

DI SPLAY: DI SPLAY SETUP 95FEB02 09:41AM  
 Voltage Ramp Initial/Post Spot Measurement

GRAPH-ICS

\* DI SPLAY MODE

LIST

\* GRAPHICS

	Xaxis	Y1axis	Y2axis
NAME	Time	Ig	Vg
SCALE	LINEAR	LOG	LINEAR
MIN	0.0000000 sec	1.00000000uA	0.00000000 V
MAX	5.0000000 sec	100.0000000mA	30.000000 V

\* GRID \* LINE PARAMETER

\* DATA VARIABLES

GRAPHICS  
 Select Display Mode with softkey or rotary knob.

I

Figure 2-26

**DISPLAY: ANALYSIS SETUP Page for Ramped Stress**

DI SPLAY: ANALYSIS SETUP 95FEB02 09:41AM  
 Voltage Ramp Initial/Post Spot Measurement

NORMAL

\* LINE1: [ ]

GRAD

TANGENT

\* LINE2: [ ]

REGRES-SION

\* MARKER: At a point where  
 [ Vg ] = [ MAX(Vg) ]  
 [ ]

\* Interpolate: [ OFF ]

DISABLE

Select Line Mode with softkey or rotary knob.

I

## Proof of Equations

This section provides the information on how to solve the equations given in “J-Ramp Stress Test” on page 2-5.

### Step Increase Factor ( $F$ )

$N$  steps per decade ( $N = 10, 25, \text{ or } 50$ ) gives the following equation:

$$10 \times I_0 = I_0 \times F^N$$

Solving for  $F$  gives the following:

$$10 = F^N$$

$$\log_{10} 10 = \log_{10} F^N$$

$$1 = N \times \log_{10} F$$

$$1/N = \log_{10} F$$

$$F = 10^{1/N}$$

So  $F$  can be one of the following:  $10^{1/10}$ ,  $10^{1/25}$ , or  $10^{1/50}$ . In the JRAMP sample program,  $F$  is specified by the `Factor` variable.

### Step Time (*Step\_time*)

Relation between  $N$  (steps per decade) and  $F$  (step increase factor) is:

$$10 = F^N$$

$$\log_{10} 10 = \log_{10} F^N$$

$$1 = N \times \log_{10} F$$

$$N = 1 / \log_{10} F$$

So,

$$\text{Step\_time} = \frac{0.5}{N} = \frac{0.5}{\frac{1}{\log_{10} F}} = 0.5 \times \log_{10} F$$

The sample program sets  $N$  (`Fact$`) according to the  $F$  (`Factor`) that is set.

### Current Stop Value (*Istop*)

The forced current  $I$  is a function of time  $t$ , so the accumulated charge to the oxide is:

$$\int_0^n I(t) dt = \int_0^n I_0 \cdot F^n \cdot T_s \cdot dn = q_{max} \cdot Area$$

Where,  $I(t) = I_0 \times F^n$ ,  $t = n \times T_s$  (time),  $n$  is step number,  $T_s$  is step time.

You want to solve to find the step number ( $n$ ) of the step when the maximum allowed charge density is reached:

$$\int_0^n I_0 \cdot F^n \cdot T_s \cdot dn = q_{max} \cdot Area$$

$$I_0 \cdot T_s \cdot \int_0^n F^n \cdot dn = q_{max} \cdot Area$$

$$I_0 \cdot T_s \cdot \frac{1}{\log_{10} F} [F^n]_0^n = q_{max} \cdot Area$$

$$\frac{I_0 \cdot T_s}{\log_{10} F} (F^n - 1) = q_{max} \cdot Area$$

$$F^n - 1 = \frac{q_{max} \cdot Area \cdot \log_{10} F}{I_0 \cdot T_s}$$

$$F^n = \frac{q_{max} \cdot Area \cdot \log_{10} F}{I_0 \cdot T_s} + 1$$

$$n \cdot \log_{10} F^n = \log_{10} \left( \frac{q_{max} \cdot Area \cdot \log_{10} F}{I_0 \cdot T_s} + 1 \right)$$

$$n = \frac{1}{\log_{10} F} \cdot \log_{10} \left( \frac{q_{max} \cdot Area \cdot \log_{10} F}{I_0 \cdot T_s} + 1 \right)$$

So,  $I_{stop}$  is as follows, where  $M$  is the minimum integer that satisfies  $M \geq n$ . In the JRAMP sample program,  $M$  is the `Step_n` variable:

$$I_{stop} = I_0 \times F^M$$

---

**NOTE**

Assuming " $y = a^x$ ,  $a$ : constant", you can get the following:

$$\log y = \log a^x = x \times \log a$$

$$(\log y)' = \log a$$

$$y' \times 1/y = \log a$$

$$y' = (\log a) \times y = (\log a) \times a^x$$

So, the integration of  $a^x$  is:

$$\int a^x = \int \frac{y'}{\log a} dx = \frac{1}{\log a} \int (y') dx = \frac{1}{\log a} \cdot y = \frac{a^x}{\log a}$$

The result of this integration is used to go from 2nd to 3rd step of above solution (integration of  $F^n$ ).

---

J-RAMP  
Proof of Equations

---

---

**3            SWEAT**

---

## SWEAT

SWEAT means Standardized Wafer-level Electromigration Accelerated Test, which is an accelerated electromigration test for microelectronic metallization on the wafer.

This test can quickly provide data for monitoring metal reliability and process consistency.

This operation manual describes a sample SWEAT program running on the 4155/4156, and how to use and customize the program. The program is written in the Instrument BASIC (IBASIC), and is ready to run on the built-in IBASIC controller of the 4155/4156.

“SWEAT” describes the SWEAT procedure and terminology.

“Basic Operation” describes the SWEAT methodology using the 4155/4156, how to execute the sample program, and program overview.

“Customization” describes the customization procedure. This procedure is very important because you probably need to modify the program to suit your test device.

“Setup files” shows the 4155/56 page settings that are stored in the setup files.

## SWEAT

This section describes the SWEAT procedure (based on the proposed JEDEC 4-June-92 standard) and related terminology.

### Overview

SWEAT evaluates sensitivity of metal lines to failure caused by electromigration.

Figure 3-1 shows the flow of the SWEAT test according to the JEDEC proceeding titled "A PROCEDURE FOR EXECUTING SWEAT" (4-Jun-92).

Figure 3-1 SWEAT Algorithm Flow

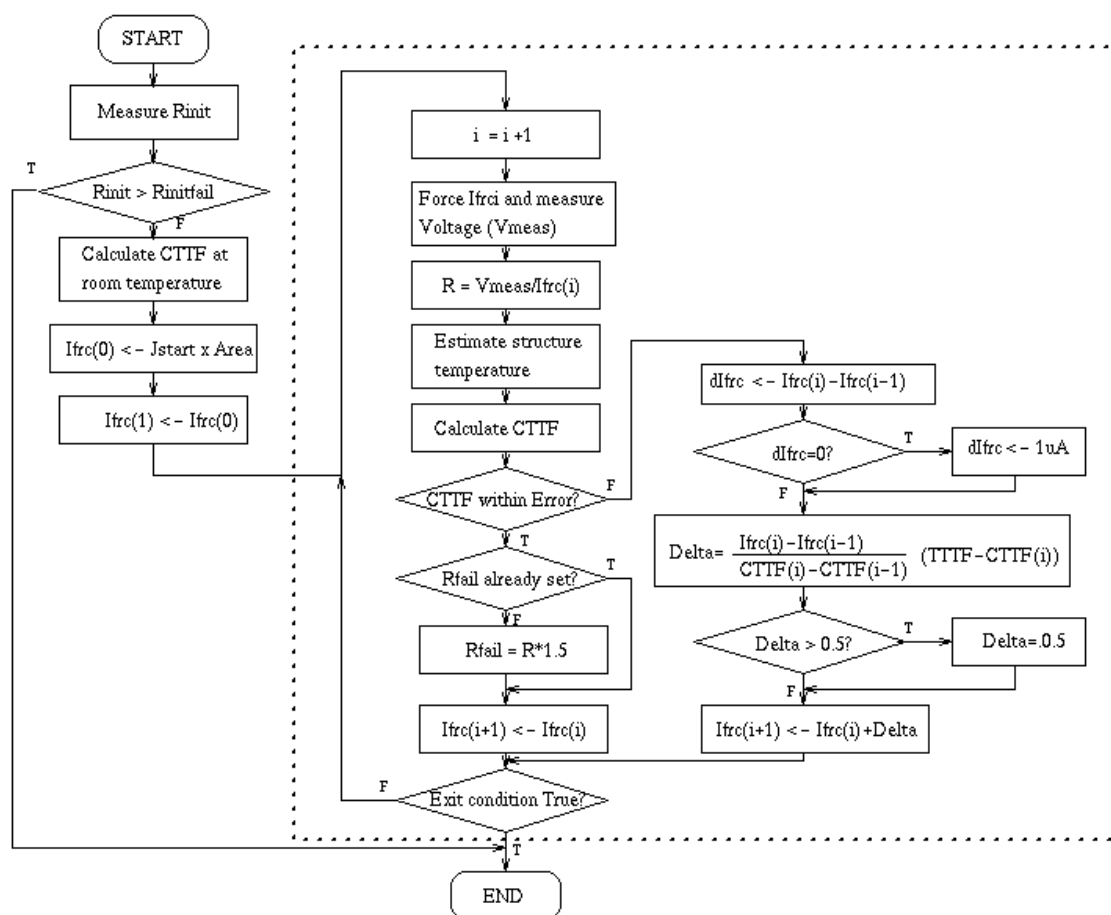

First, the initial structure resistance is measured. If it is too high, the program finishes.

If initial structure resistance is within limits, the stress/resistance measurement loop is performed, which is the part inside the dotted square in Figure 3-1. This loop is a feedback control loop that does the following:

1. An initial current is forced through the test structure, and the calculated time to failure (CTTF) is calculated by using Black's equation. The current is adjusted in a feedback loop until the CTTF is within a desired range ( $TTTF \pm \text{Errband}$ ), where TTTF is the target time-to-failure. This feedback period to reach the desired range is called the *settling period*. The structure resistance is measured when CTTF becomes within  $TTTF \pm \text{Errband}$ . This is called the *settling resistance*.
2. After settling, the current is continuously forced to the test structure. By continuously adjusting the current, CTTF is forced to track TTTF. This period is called the hold period. This adjustment is performed by the same feedback control algorithm as used during the settling period. Gradually, the structure resistance increases due to electromigration voids (CTTF deviates from TTTF).

The hold period continues until the structure resistance is  $1.5 \times \text{settling resistance}$ . This means the structure has ruptured (failed).

## Input Parameters

Following table shows the input parameters required for the SWEAT procedure and the values used in the sample program. You can change these values to suit your device.

Input Parameter (Default Value)	Description
Tcr (2.E-3 °K <sup>-1</sup> )	Temperature coefficient of resistance (This value should be measured before performing the SWEAT evaluation.) See JEDEC No.33 <i>Standard Method for Measuring and Using the Temperature Coefficient of Resistance to Determine the Temperature of a Metallization Line</i> for how to measure TCR.
Rinitfail (1000 Ω)	Maximum allowable structure resistance during the initial resistance test.
Ttff (190 sec)	Target time to failure.
Ttt (1000 sec)	Total testing time. Testing stops if this time is reached.
Troom (298 °K)	Room temperature.
Vcomp (20 V)	Voltage compliance.
Isrc_max (1 A)	Maximum limit of current source.
Errband (2 sec)	Allowable difference between CTTF and TTTF during feedback control loop. If difference is greater than this value, forced current is adjusted.
Area (1E-8 cm <sup>2</sup> )	Cross sectional area of the narrowest region of the structure.
Jstart (1.0E-2/Area A/cm <sup>2</sup> )	Starting current density.
Acc (1.E+10 sA <sup>2</sup> /cm <sup>4</sup> )	Acceleration factor for Black's Equation.
Blk (2)	Current density factor ( <i>n</i> ) for Black's Equation.
Ea (0.6 eV)	Activation energy for the metallization for Black's Equation.

## Initial Resistance (Rinit) Measurement

Rinit is the structure resistance at room temperature and low current density.

The algorithm assumes that the ambient temperature is 298 °K and the current density is sufficiently low so that Joule heating is negligible. Actual Rinit is measured when voltage (small enough not to cause the Joule heating) is applied to the structure.

## CTTF

CTTF is the Calculated Time to Failure of the structure based on Black's Equation:

$$CTTF = Acc * J^{-n} e^{Ea/kT}$$

<b>Acc :</b>	Acceleration factor
<b>J :</b>	Current density
<b>Ea :</b>	Activation energy for the metallization
<b>n :</b>	Current density factor
<b>k :</b>	Boltzman's constant
<b>T :</b>	Temperature in °K.

## Rfail

Rfail is used to judge if the test structure fails during the stress/resistance measurement loop. Rfail is defined as  $1.5 \times \text{settling resistance}$ .

## Exit Condition

SWEAT program ends if any of following occurs. The Ex\_cond variable is set to indicate the exit condition and is saved to the result data file.

- Rinit is greater than Rinitfail (1000 Ω in sample program). Ex\_cond = 10000.
- Rfail has been set and the structure resistance is greater than Rfail. This is the expected exit condition for the test. Rfail is defined as  $1.5 \times \text{settling resistance}$ . Ex\_cond = 1.
- Total testing time has elapsed. Ex\_cond = 2.
- New force current for feedback control is larger than the current limit. Ex\_cond = 3.
- Voltage compliance of the current source has been reached. Ex\_cond = 4.

## Output Parameters

The SWEAT sample program stores the following results in the result data file when the test is exited:

- Exit Condition  
This is the number of the exit condition that caused the test to terminate.
- Time To Fail (TTF)  
TTF is the time (in seconds) at which the structure failed.
- Fail Resistance  
This is the resistance at TTF, which is the structure resistance value when structure resistance exceeds  $R_{fail}$  ( $1.5 \times \text{settling resistance}$ ).
- Fail J (Iforce/Area)  
This is the applied current density at TTF based on the area of the narrowest region of the test structure.
- Temperature at Fail  
This is the estimated temperature of the narrowest region of the test structure at TTF.

---

## Basic Operation

This section describes the methodology for using the 4155/4156 to perform SWEAT, required equipment, required program and files, how to execute the sample program, and sample program overview.

### Methodology

The entire SWEAT procedure can be performed by executing the SWEAT sample program.

The program loads measurement setups (into the 4155/56) that were previously saved to the measurement setup files on diskette. These setup files are included on the diskette with the sample program. If you need to modify a setting, you can easily modify them in fill-in-the-blank manner from the 4155/56 front panel, then resave to the file.

SWEAT test needs a controller to make complicated calculations (such as CTTF) and to control the forced current during the stress/resistance measurement loop. When using the 4155/4156, two controllers are available: an external computer or the built-in IBASIC controller of the 4155/4156. The measurement data (CTTF versus Time) is displayed on the GRAPHICS page of the 4155/4156. Other result data is saved to a result data file.

The SWEAT sample program is created assuming that the 4155/56 built-in IBASIC controller is used. The sample program can easily be modified to run on HP BASIC or IBASIC on an external computer. Refer to “Customization” on how to modify the program to run on an external computer.

If you use a high performance external computer, such as *HP 9000 S382*, you can speed up the feedback loop and reduce the settling period.

An HPSMU is necessary to force high current greater than 100mA, and must be connected to SMU5 port. Measurement mode is set to **Sampling mode**, and SMU5 is set to **Standby mode** so that current is continuously forced even when measurement is not being made, such as during calculation.

### Initial Resistance (Rinit) Measurement

First, Rinit is measured while 0.1 V is applied to the test structure. Applied voltage value (0.1 V) is assumed to be low enough not to cause Joule heating. Rinit measurement circuit is shown in Figure 3-2.

This measurement setup is in the RINIT.MES file on the diskette, and the sample program loads this setup into the 4155/56 at the beginning of the measurement. You can easily modify this measurement setup if desired. You just set the setup pages as desired from the front panel, then save the new setup to the RINIT.MES file.

Figure 3-2 Rinit Measurement Circuit

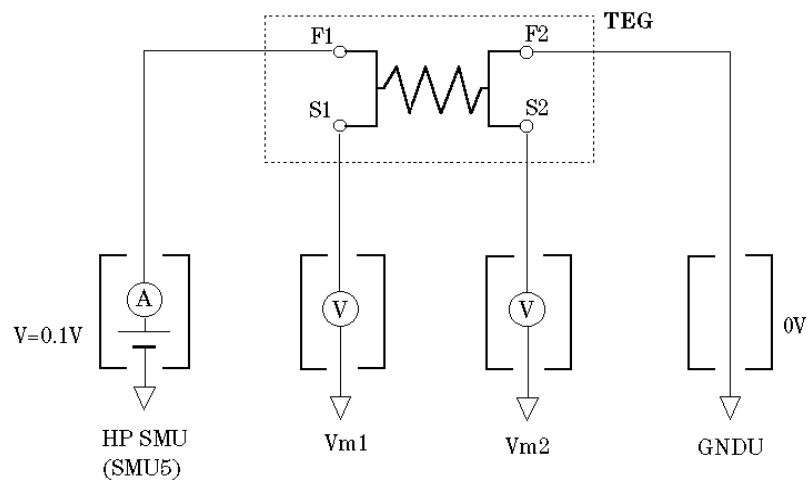

### Stress/Resistance Measurement Loop

After Rinit measurement, sample program loads a new setup into the 4155/56, and a feedback loop is entered. Current ( $I_{force}$ ) is applied to the test structure.  $I_{force}$  is controlled and adjusted until CTF (computed using the measurement results) has settled close enough to TTF (within  $\pm$  Errband). The 4155/4156 is set to sampling mode to make a single spot measurement. SMU5 port is set to standby mode to keep the current continuously applied while measurements and calculations are performed.

Measurement circuit of this feedback loop is shown in Figure 3-3. Figure 3-4 and Figure 3-5 show an example CHANNEL DEFINITION and SAMPLING SETUP page. This measurement setup is stored in the IFVM.MES file on the diskette.

Figure 3-3 Stress/Resistance Measurement Circuit

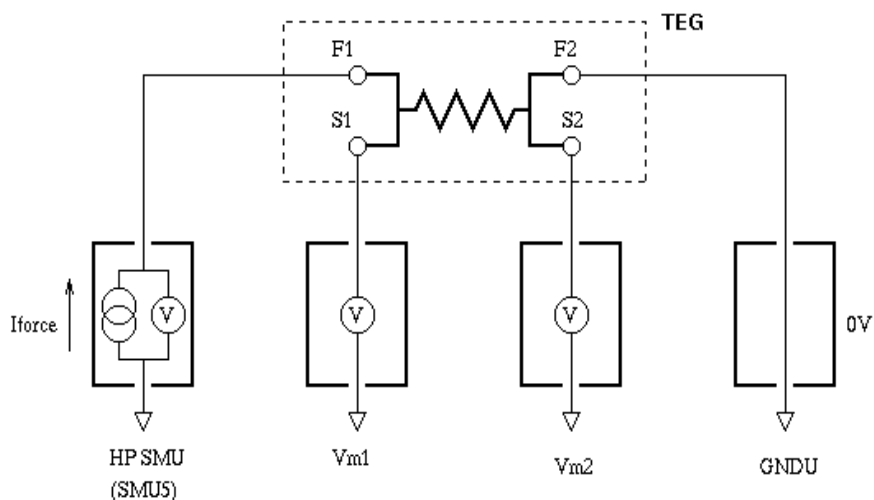

Figure 3-4 CHANNEL DEFINITION Page

CHANNELS: CHANNEL DEFINITION 94JUL03 07:27AM

\* MEASUREMENT MODE  
SAMPLING

\* CHANNELS

UNIT	VNAME	I NAME	MODE	FCTN	STBY	SERIES RESISTANCE
SMU1:HR						0 ohm
SMU2:HR						
SMU3:HR						
SMU4:HR						
SMU5:HP	vfr0	ifrc	I	CONST	ON	0 ohm
VSU1		.....				
VSU2		.....				
VMU1	vm1	.....	V	.....	.....	
VMU2	vm2	.....	V	.....	.....	
PGU1		.....				
PGU2		.....				
GNDU	vgnd	.....	COMMON	CONST	.....	

Enter Voltage Name. (max 6 chars.)

CHANNEL DEF USER FCTN USER VAR

DELETEROW

NEXT PAGE

Figure 3-5 SAMPLING SETUP Page

MEASURE: SAMPLING SETUP 94JUL03 07:29AM

\* SAMPLING PARAMETER

MODE	LINEAR
INITIAL INTERVAL	2.00 ms
NO. OF SAMPLES	1
TOTAL SAMP. TIME	AUTO
HOLD TIME	0.000000 s
FILTER	OFF

\* STOP CONDITION

ENABLE/DISABLE	DISABLE
ENABLE DELAY	0.000000 s
NAME	
THRESHOLD	0.00000000
EVENT	Val > Th
EVENT NO.	1

\* CONSTANT

UNIT	SMU5:HP			
NAME	ifrc			
MODE	I			
SOURCE	1.0000 mA	.....	.....	.....
COMPLIANCE	20.000 V	.....	.....	.....

LINEAR  
Select Sampling Mode with softkey or rotary knob.

SAMPLING SETUP MEASURE SETUP OUTPUT SEQ

PREV PAGE NEXT PAGE

After every measurement, the program updates only Iforce.

When CTF becomes within specified range of TTTF, the structure resistance is measured. This is called the *settling resistance*.

Then, current continues to be forced and adjusted in the stress/resistance measurement loop until sufficient electromigration has occurred to change the structure resistance so that it is greater than Rfail ( $1.5 \times \text{settling resistance}$ ).

## Required Equipment

The following are required to use the SWEAT sample program:

- Agilent 4155 or Agilent 4156 Semiconductor Parameter Analyzer
- Agilent 41501 SMU and Pulse Generator Expander furnished with HPSMU (Option 410 or 412)
- Four triaxial cables
- Probe station
- This operation manual
- Diskette that contains sample program and setup files.

## Files on the Diskette

Make sure that following files are on the diskette:

- SWEAT  
SWEAT sample program.
- RINIT.MES  
File for setting up the 4155/56 to measure initial resistance (Rinit).
- IFVM.MES  
File for setting up the 4155/56 to measure resistance during stress/resistance measurement loop, and to plot CTTF versus Time.

## Execution

Before executing the program, you may need to customize the program to suit your test device. If so, see “Customization”.

1. Connect the 4155/4156 to your test device. Refer to Figure 3-2.
2. Insert diskette that contains SWEAT program into built-in drive of the 4155/4156 or drive of external controller.
  - To load the program into the 4155/56, press the IBASIC Display key until All IBASIC screen is displayed. Then, type the following: GET "SWEAT" Enter
  - To load the program into an external controller, type the following on the command line of external controller display: GET "SWEAT: ,msus" Enter

Where *msus* is specifier of mass storage device that contains the SWEAT program. If default drive is used, just type GET "SWEAT" Enter.

Then, insert the diskette into the built-in drive of the 4155/56 because the 4155/56 will need to load the measurement setup files.

3. Press the IBASIC Display key until All Instrument screen is displayed.
4. To run SWEAT program in the 4155/56, press RUN front-panel key.

To run SWEAT program in external controller, type RUN Enter.

Measurement results will be displayed on GRAPHICS page of the 4155/4156.

Figure 3-6

### Measurement Result Example

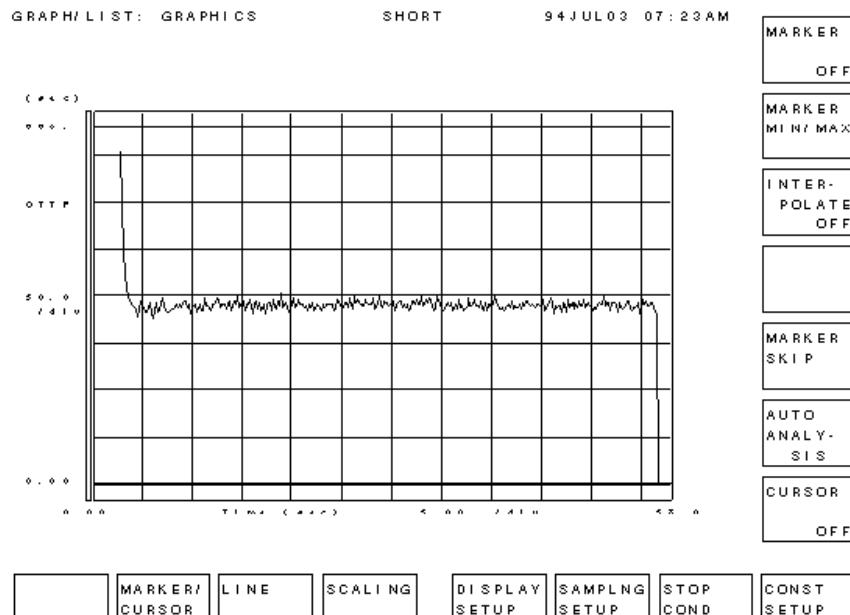

## Sample SWEAT Program Overview

For the actual program code, edit SWEAT program.

Line or Subprogram Name	Description
1510	Sets the 4155/4156's address. 800 means the 4155/4156 will be controlled by built-in IBASIC controller.
1530 - 1560	Creates data file for storing results.
1590 - 1600	Defines names for setup files that are on diskette.
1630 - 1750	Assigns input parameter values.
1800 - 1880	Loads Rinit measurement setup file, then measures Rinit.
1930	Loads setup file for stress/resistance measurement and displaying results.
1990	Sets standby mode.
2050 - 2400	Performs stress/resistance measurement loop.
2460 - 2500	Saves measured parameters into the result data file.
2520 - 2540	Displays "CTTF vs. Time" graph.
Init_hp415x	Subprogram for initializing the 4155/4156.
Get_file	Subprogram for loading setup file from the diskette into the 4155/56.
Rinit_meas	Subprogram for measuring Rinit.
Calc_cttf	Subprogram for calculating CTTF.
Calc_tmp	Subprogram for calculating structure temperature.
Sweat_graph	Subprogram for transferring measurement data from the 4155/56 user variable to program array variables, and setting up the "CTTF vs. Time" graph.

---

## Customization

This section describes how to customize the sample program to suit your test device.

### Using External Computer or Built-in Controller

Line 1510 specifies the address of the 4155/4156:

```
1510 ASSIGN @Hp415x TO 800      !Address setting
```

- If you will execute the SWEAT program using the 4155/4156's built-in IBASIC controller, use the above address (800).
- If you want to execute the SWEAT program on an external computer, use *XYZ* instead of 800, where *X* is the GPIB select code, and *YZ* is the GPIB address of the 4155/56.

For example, if the GPIB select code is 7, and the GPIB address of the 4155/4156 is 17, modify as follows:

```
1510 ASSIGN @Hp415x TO 717    !Address setting
```

Also, set the 4155/4156 to NOT SYSTEM CONTROLLER on SYSTEM: MISCELLANEOUS page.

### Specifying Setup File to Load

Two setup files are required to set up the 4155/56 for the SWEAT measurement: Rinit measurement setup file and stress/resistance measurement setup file.

These setup files are defined on lines 1590 and 1600.

```
1580 !----- File name setting -----  
1590 Ri_file$="RINIT.MES"      !Rinit measurement setup file  
1600 Ist_file$="IFVM.MES"     !Istress measurement setup file
```

If you want to use other setup files instead, store the setup files on the diskette, then modify the file names on the above lines.

## File for Saving Measurement Results

The following lines create an ASCII file for saving the extracted parameters:

```
1530 File$=TIME$(TIMEDATE)           !
1540 File$=File$[1,2]&File$[4,5]     !Creating
1550 CREATE File$,1                  !      Data
1560 ASSIGN @File1 TO File$;FORMAT ON !      File
```

Lines 1530 and 1540 create a file with name that is the present time: *HHMM*, where *HH* = hour and *MM* = minute.

If you want to change the file name, modify line 1540, as shown in following example:

```
1540 File$="TESTDATA"
```

Line 1550 creates a DOS file, and `FORMAT ON` in line 1560 means ASCII file. So, extracted parameters will be stored in an ASCII-format DOS file.

In the sample program, the following result parameters will be stored in the file:

- Exit condition
- Time to failure
- Failure resistance
- Failure temperature
- Failure current density

You can add result parameters to be stored in the file by adding lines in the following format:

```
OUTPUT @File1,"parameter"
```

For example, if you want to store CTTF, structure temperature (`T_now`), time, and resistance (`R_now`) during the stress/resistance measurement loop, add the following two lines:

```
2172 OUTPUT @File1;"I=";I;"CTTF(I)=";Cttf(I);"(s) T_now=";T_now;"(K) "
2174 OUTPUT @File1;"Time=";Time(I);"(s) R_now=";R_now;"(ohm) "
```

## Setting up Input Parameters

Input parameter values are assigned from line 1620 to 1720. Modify these values according to your test device.

### NOTE

Input parameters for CTF calculation are *not* defined here, but are defined in the Calc\_cttf subprogram. See next section.

```

1620 !----- Parameter setting -----
1630 Tcr=2.E-3           !Temperature Coefficient of R (1/K)
1640 Rinit_fail=1000    !Unallowable initial resistance value (ohm)
1650 Tttf=190           !Target Timeto Failure (sec)
1660 Ttt=1000           !Total Testing Time (sec)
1670 Troom=298          !Room Temperature (K)
1680 Vcomp=20           !Voltage compliance of every port
1690 Isrc_max=1         !Current Limit of HPSMU
1700 Errband=2         !Allowable Error Band (sec.)
1710 Area=1.E-8        !Narrowest cross section (cm^2)
1720 Jstart=1.0E-2/Area !Initial current density

```

Parameter	Description	Default
Tcr	Temperature coefficient of R	2.E-3 °K <sup>-1</sup>
Rinit_fail	Maximum allowable initial resistance value	1000 Ω
Tttf	Target time to failure	190 sec
Ttt	Total allowed testing time	1000 sec
Troom	Room temperature	298 °K
Vcomp	Voltage compliance	20 V
Isrc_max	Current limit of HPSMU	1 A
Errband	Allowable error band	2 sec
Area	Narrowest cross section	1.E-8 cm <sup>2</sup>
Jstart	Initial current density	1.0E-2/Area (A/cm <sup>2</sup> )

## Setting up Input Parameters Related to CTF Calculation

The following input parameters are used in Black's Equation to calculate CTF in the Calc\_cttf subprogram. If you want to modify these values, change following lines.

```

2990 !----- parameter setting -----
3000 Acc=1.E+10        !Acceleration factor (s*A^2/cm^4)
3010 Blk=2            !Dimensionless const for Black
3020 Ea=.6            !Activation Energy (eV)

```

Parameter	Description	Default
Acc	Acceleration factor	1.E+10 (sA <sup>2</sup> /cm <sup>4</sup> ).
Blk	Exponent for current density ( <i>n</i> in Black's equation)	2
Ea	Activation Energy for metallization	0.6 (eV)

## How to Reduce the Settling Time of CTTF

If many operations are performed (such as displaying results) during the settling period, the intervals between stress current adjustments becomes long. As a result, it takes a long time for CTTF to settle close to TTTF. So, the test structure may become OPEN before the CTTF settles. This leads to unreliable measurement results.

The following are hints for reducing the settling time of CTTF.

### Display the Results after Stress/Resistance Measurement Loop

The sample SWEAT program displays measurement results *after* the stress/resistance loop is exited. The following describes how to modify the SWEAT program so that measurement results are displayed *during* the stress/resistance measurement loop. If you make this modification, the CTTF settling period *becomes longer*.

The Sweat\_graph subprogram is used to display the measurement results. In the SWEAT program, the Sweat\_graph subprogram is called in line 2420, which is after the stress/resistance measurement loop is exited. The stress/resistance measurement loop is from line 2020 to 2410.

If you want to see the measurement results during the stress/resistance measurement loop, modify the SWEAT program to call the Sweat\_graph subprogram after line 2170 as shown in the following, and add lines 3490 and 3500 to the Sweat\_graph subprogram.

```
2170 Calc_cttf(Cttf(I),Iforce(I)/Area,T_now) !CTTF calculation
2175 Sweat_graph(I,Time(*),Cttf(*))
2180 !
      :      :      :
3500 OUTPUT @Hp415x;" :PAGE:GLIS"      !Display Graphic page
3510 OUTPUT @Hp415x;" :DISP ON"        !Enable Display Update
3520 OUTPUT @Hp415x;" :DISP OFF"       !Disable Display Update
```

The above modification displays the measurement results during the stress/resistance measurement loop, so the CTTF settling period becomes long.

### Use a High Performance External Controller

If you use a high performance external controller (such as the HP 9000 S382 SPU), the calculation time is reduced.

### Use Optimum $J_{START}$

If difference is too great between  $J_{START}$  and the stress current value when CTTF is settled, the CTTF settling time may become long. So, vary  $J_{START}$  value for first several measurements to find the optimum  $J_{START}$  value.

In the sample program,  $J_{START}$  is defined so that the first stress current is 1 mA.

## Reducing Parameter Extractions during Measurement

If many parameters are extracted during the stress/resistance measurement loop, especially when the stress current is being adjusted, the time interval between current adjustments becomes long. (Extract means to transfer the parameter from the 4155/56 to controller.)

So, do not extract parameters that are not important for the measurement results. In the sample program, only the resistance is extracted, which is required to calculate CTF.

If you want to extract parameters other than resistance, you need to modify the setup file IFVM.MES and SWEAT program as described in the example below.

First, add parameter name to be extracted to the DISPLAY SETUP page shown in Figure 3-7. In this example, Vm1 and Vm2 monitored by VMUs are added.

You need to save the new setup to the IFVM.MES file.

Figure 3-7

### Modification on DISPLAY SETUP Page

```

DI SPLAY: DI SPLAY SETUP                                94JUL28 04:09AM

```

^ DI SPLAY MODE		V f r e
LIST		I f r e
^ LI ST		V m 1
No.	NAME	V m 2
1	R	
2	V m 1	
3	V m 2	
4		V m 2
5		
6		
7		
8		V g n d

Then, add following lines to the SWEAT program:

```

2130 OUTPUT @Hp415x;"TRAC? 'R'"      !ExtractR_now
2140 ENTER @Hp415x;R_now              !
2142 OUTPUT @Hp415x;"TRAC? 'Vm1'"    !Extract Vm1
2144 ENTER @Hp415x;Vm1                !
2146 OUTPUT @Hp415x;"TRAC? 'Vm2'"    !Extract Vm2
2148 ENTER @Hp415x;Vm2                !
2150 !

```

#### NOTE

Adding parameters to be extracted *increases* the CTF settling time.

## Defining $J_{START}$

Test structure resistance is usually very small at first. So, the voltage drop across the test structure is very small if the start current is small. The voltage resolution of the VMU in sampling mode is 1 mV. It is very important for the current to be great enough to cause enough voltage drop to get an accurate resistance value. Modify following part if you need to change  $J_{start}$ .

```
1710 Area=1.E-8           !Narrowest cross section (cm^2)
1720 Jstart=1.0E-2/Area   !Initial current density
```

Use the following equation to determine the best  $J_{START}$ :

$$J_{START} * Area * Rinit > 10 \text{ mV}$$

## Current Adjustment Routine

The sample program is made based on the proposed JEDEC 4-June-92 standard, but the algorithm associated with the current adjustment routine in the stress/resistance measurement loop may not work for some test structures.

```
2190 IF Cttf(I)<Tttf-Errband OR Cttf(I)>Tttf+Errband THEN
2200   Delta_ifrc=Iforce(I)-Iforce(I-1)
2210   IF Delta_ifrc=0 THEN Delta_ifrc=1.E-6
2220   Delta=Delta_ifrc*(Tttf-Cttf(I))/Cttf(I)-Cttf(I-1)
2230   IF Delta>.05 THEN Delta=.05
2240   IF Delta<-.05 THEN Delta=-.05
2250   Iforce(I+1)=Iforce(I)+Delta
2260 ELSE
2270   IF Rf_set=0 THEN      !
2280     Rfail=R_now*1.5    !Set Rfail value
2290     Rf_set=1          !
2300   END IF
2310   Iforce(I+1)=Iforce(I)
2320 END IF
```

This routine is slightly different from the proposed JEDEC 4-June-92 standard. In lines 2230 and 2240, Delta is set to 0.05A (or -0.05A) if calculated Delta exceeds 0.05A (or -0.05A). But in proposed JEDEC 4-June-92 standard, Delta is set to 0.5A (or -0.5A) if calculated Delta exceeds 0.5A (-0.5A).

This modification is made due to the maximum current limit (1A) of HPSMU.

If the sample program does not work properly, try modifying Delta definition, Jstart, or Errband until it works properly.

## Setup files

This section describes the settings of the 4155/56 setup pages that are stored in the RINIT.MES and IFVM.MES files. If you change the setup page settings, you need to save the settings to the files.

### Setup File for Initial Resistance Measurement

The measurement setups stored in RINIT.MES file are used for the initial resistance (Rinit) measurement. The setups of each page are shown in Figure 3-8 to Figure 3-11.

### Setup File for Stress/Resistance Measurement

The measurement setups stored in IFVM.MES file are used for the stress/resistance measurement loop and for displaying results (CTTF versus Time) on graph. The setups of each page are shown in Figure 3-12 to Figure 3-18.

Figure 3-8 CHANNEL DEFINITION Page for Initial Resistance Measurement

```

CHANNELS: CHANNEL DEFINITION          94MAR16 06:35AM
Rinit measurement

* MEASUREMENT MODE
  SAMPLING

* CHANNELS
  MEASURE
  UNIT  VNAME  I NAME  MODE  FCTN  STBY  SERIES RESISTANCE
  SMU1: HR
  SMU2: HR
  SMU3: HR
  SMU4: HR
  SMU5: HP  Vfr c  I fr c  V     CONST  0 ohm
  VSU1
  VSU2
  VMU1     Vm1   -----  V     -----  -----
  VMU2     Vm2   -----  V     -----  -----
  PGU1
  PGU2
  GN DU    Vgnd  -----  COMMON CONST  -----

  MEM1 M B-Tr VCE-IC
  MEM2 M FET VDS-ID
  MEM3 M FET VGS-ID
  MEM4 M DIODE VF-IF

  SWEEP
  SAMPLING
  DEFAULT MEASURE SETUP
  MEM1 M B-Tr VCE-IC
  MEM2 M FET VDS-ID
  MEM3 M FET VGS-ID
  MEM4 M DIODE VF-IF

SAMPLING
Select Measurement Mode with softkey or rotary knob.
CHANNEL USER USER
DEF      FCTN  VAR      [ ]      [ ]      [ ]      [ ]      [ ]      [ ]
  
```

Figure 3-9 USER FUNCTION DEFINITION Page for Initial Resistance Measurement

CHANNELS: USEF FUNCTION DEFINITION 94JUL07 11:50PM  
Rinit measurement

^USER FUNCTION

NAME	UNIT	DEFINITION
Rinit	ohm	(Vm1-Vm2)/Ifrc

Rinit  
Enter User Function Name. (max 6 chars.)

CHANNEL DEF	USER FCTN	USER VAR				PREV PAGE	NEXT PAGE
-------------	-----------	----------	--	--	--	-----------	-----------

Figure 3-10 SAMPLING SETUP Page for Initial Resistance Measurement

MEASURE: SAMPLING SETUP 94JUL07 11:51PM  
Rinit measurement

^SAMPLING PARAMETER

MODE	LINEAR	ENABLE/DISABLE	DISABLE
INITIAL INTERVAL	4.00 ms	ENABLE DELAY	0.0000000 s
NO. OF SAMPLES	1	NAME	
TOTAL SAMP. TIME	AUTO	THRESHOLD	0.00000000
		EVENT	Val > Th
		EVENT NO.	1

HOLD TIME 500.0ms

FILTER OFF

^CONSTANT

UNIT	SMUS: MP			
NAME	Vfrc			
MODE	V			
SOURCE	100.0mV			
COMPLIANCE	100.00mA			

1  
Enter No of Sampling (1 to 10001).

SAMPLING SETUP		MEASURE SETUP	OUTPUT SEQ			PREV PAGE	NEXT PAGE
----------------	--	---------------	------------	--	--	-----------	-----------

Figure 3-11 DISPLAY SETUP Page for Initial Resistance Measurement

DISPLAY: DISPLAY SETUP 94JUL07 11:52PM

Rinit measurement

GRAPH-ICS

LIST

LIST

^ DISPLAY MODE

LIST

^ LIST

No.	NAME
1	Rinit
2	Ifrc
3	Vm1
4	Vm2
5	Vfrc
6	
7	
8	

^ DATA VARIABLES

LIST

Select Display Mode with softkey or rotary knob.

DISPLAY ANALYSIS PREV NEXT  
SETUP SETUP PAGE PAGE

Figure 3-12 CHANNEL DEFINITION Page for Stress / Resistance Measurement

CHANNELS: CHANNEL DEFINITION 94JUL03 07:27AM

MEASUREMENT MODE

SAMPLING

^ CHANNELS

UNIT	MEASURE				STBY	SERIES RESISTANCE
	VNAME	I NAME	MODE	FCTN		
SMU1:HR						0 ohm
SMU2:HR						
SMU3:HR						
SMU4:HR						
SMUS:HP	Vfrc	Ifrc	I	CONST	ON	0 ohm
VSU1		.....				
VSU2		.....				
VMU1	Vm1	.....	V	.....	.....	
VMU2	Vm2	.....	V	.....	.....	
PGU1		.....				
PGU2		.....				
GNDU	Vgnd	.....	COMMON	CONST	.....	

DELETE ROW

Enter Voltage Name. (max 6 chars.)

CHANNEL USER USER NEXT  
DEF FCTN VAR PAGE

**Figure 3-13 USER FUNCTION DEFINITION Page for Stress / Resistance Measurement**

CHANNELS: USER FUNCTION DEFINITION 94JUL07 11:41PM

* USER FUNCTION		
NAME	UNIT	DEFINITION
R	ohm	ABS({ Vm1 - Vm2 } / { I f r c })

Enter User Function Name. (max 6 chars.)

CHANNEL DEF	USER FCTN	USER VAR				PREV PAGE	NEXT PAGE
-------------	-----------	----------	--	--	--	-----------	-----------

**Figure 3-14 USER VARIABLE DEFINITION Page for Stress / Resistance Measurement**

CHANNELS: USEF VARIABLE DEFINITION 94JUL07 11:46PM

* USER VARIABLE		
NAME	UNIT	SIZE
Time	sec	1
CTTF	sec	1

Time

Enter User Variable Name. (max 6 chars.)

CHANNEL DEF	USER FCTN	USER VAR				PREV PAGE	NEXT PAGE
-------------	-----------	----------	--	--	--	-----------	-----------

Figure 3-15 SAMPLING SETUP Page for Stress / Resistance Measurement

MEASURE: SAMPLING SETUP 94JUL07 11:43PM

^ SAMPLING PARAMETER		^ STOP CONDITION	
MODE	LINEAR	ENABLE/DISABLE	DISABLE
INITIAL INTERVAL	2.00 ms	ENABLE DELAY	0.0000000 s
NO. OF SAMPLES	1	NAME	
TOTAL SAMP. TIME	AUTO	THRESHOLD	0.00000000
		EVENT	Val > Th
		EVENT NO.	1
HOLD TIME	0.000000 s		
FILTER	OFF		

^ CONSTANT				
UNIT	SMU5: MP			
NAME	I frc			
MODE	I			
SOURCE	1.0000 mA	.....	.....	.....
COMPLIANCE	20.000 V	.....	.....	.....

LINEAR  
Select Sampling Mode with softkey or rotary knob.

SAMPLING SETUP		MEASURE SETUP	OUTPUT SEQ			PREV PAGE	NEXT PAGE
----------------	--	---------------	------------	--	--	-----------	-----------

Figure 3-16 MEASURE SETUP Page for Stress / Resistance Measurement

MEASURE: MEASURE SETUP 94JUL07 11:44PM

^ MEASUREMENT RANGE				ZERO CANCEL		OFF	
UNIT	NAME	RANGE					
SMU5: MP	V frc	LIMITED 20V		OFF			
VMU1	Vm1	AUTO	.....	OFF			
VMU2	Vm2	AUTO	.....	OFF			

(\*: Old data is used.)

^ INTEGRATION TIME		
	TIME	NPLC
SHORT@	80 us	0.004
MED	20.0 ms	1
LONG	320. ms	16

^ WAIT TIME

1 ^ (DEFAULT WAIT TIME)

LIMITED  
Select Range Mode with softkey or rotary knob.

SAMPLING SETUP		MEASURE SETUP	OUTPUT SEQ			PREV PAGE	NEXT PAGE
----------------	--	---------------	------------	--	--	-----------	-----------

Figure 3-17 OUTPUT SEQUENCE Page for Stress / Resistance Measurement

MEASURE: OUTPLT SEQUENCE 94JUL07 11:45PM

^ OUTPUT SEQUENCE				^ TRIGGER SETUP	
	UNIT	NAME	MODE	ENABLE/DISABLE	DI SABLE
1	SMU5:MP	I f r o	I	FUNCTION	TRIG OUT
2	SMU2:MP			STEP DELAY	0.000 s
3	SMU3:MP			POLARITY	POSITIVE
4	SMU4:MP				
5	SMU1:MP				
6	VSU1				
7	VSU2				
8	PGU1				
9	PGU2				
10	SMU6:MP				

^ OUTPUT SEQUENCE MODE OF SAMPLING  
SIMULTANEOUS

SMU5: MP  
Select Output Sequence with softkey or rotary knob.

SAMPLING SETUP MEASURE SETUP OUTPUT SEQ PREV PAGE NEXT PAGE

SMU1: MP  
SMU2: MP  
SMU3: MP  
SMU4: MP  
SMU5: MP  
SMU6: MP  
MORE  
1 / 2

Figure 3-18 DISPLAY SETUP Page for Stress / Resistance Measurement

DISPLAY: DISPLAY SETUP 94JUL07 11:45PM

^ DISPLAY MODE  
LIST

^ LIST

No.	NAME
1	R
2	
3	
4	
5	
6	
7	
8	

^ DATA VARIABLES

LIST  
Select Display Mode with softkey or rotary knob.

DISPLAY SETUP ANALYSIS SETUP PREV PAGE NEXT PAGE

GRAPHICS  
LIST

---

---

**4            Go/NO-GO**

---

At present, incoming inspection and quality assurance inspection of semiconductor devices is extremely time-consuming due to the need to inspect a large number of different devices. It is important that the process be automated to save time. Also, the results are often different depending on the individual conducting the tests, and it is desirable that these differences be eliminated to raise the reliability of the results.

Using built-in Instrument BASIC (IBASIC) of the 4155/4156, you can turn the 4155/4156 into a functional and easy-to-use automatic incoming/outgoing inspection tester.

This operation manual describes a sample incoming/outgoing inspection program that runs on the 4155/4156, and describes how to use and customize the program. This sample program is stored on a diskette in the GONOGO file.

“GONOGO Sample Program” describes outline of GONOGO sample program.

“Basic Operation” describes basic operation of the GONOGO sample program.

“Customization” describes procedure to customize the GONOGO sample program to suit your devices.

## GONOGO Sample Program

This section gives an overview of the GONOGO sample program. The GONOGO sample program has following functions.

- Menu driven operation  
The program can basically be operated by selecting a softkey. For example, after the device is connected, you need only press the NEXT DEVICE softkey. All measurement parameters will be extracted automatically using the Auto Analysis function, then the result values are displayed in the Result column.
- Automatic binning  
You can set upper and lower limits for the result values, which are judged automatically by the program.
- Viewing all measurement curves while measurement is in progress  
It is possible to view the measurement curves while the measurement is in progress. Or to only view the results.
- Viewing a particular measurement curve  
It is possible to view a particular measurement curve. This is useful for viewing the device characteristics when the measured result is judged to be out of specification.
- Changing limits  
You can change the upper or lower limit after the program is started.
- Showing statistics  
You can display statistical results (average, maximum, minimum, standard deviation) at any time.
- Downloading to spreadsheet  
After measurement for all devices is finished, all measurement data can be downloaded to an ASCII file. You can import this file into a spreadsheet, such as LOTUS 1-2-3 or Microsoft Excel.

Figure 4-1 shows the flowchart of the GONOGO sample program.

Figure 4-1 Flowchart of GONOGO Sample Program

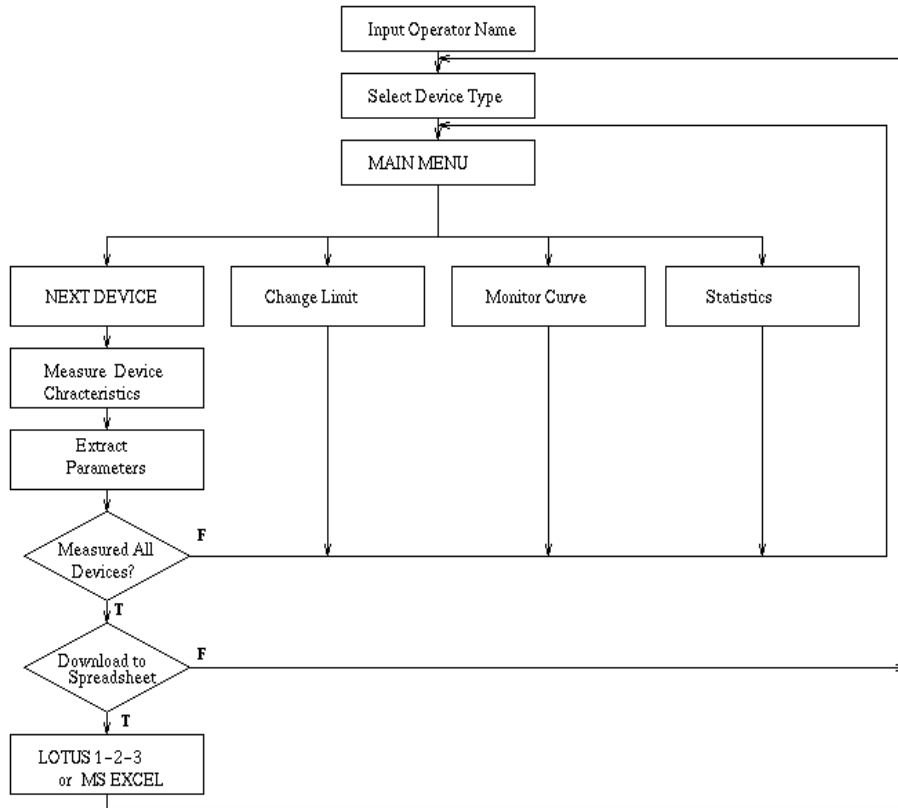

## Basic Operation

This section describes the required equipment, required program and files, connection, and how to execute the sample program.

### Required Equipment

The following are required to use the GO/NO-GO test sample program:

- Agilent 4155 or Agilent 4156
- Agilent 16442A test fixture
- Four triaxial cables
- This operation guide
- Diskette that contains sample program and the 4155/4156 setup files.

### Files on the Diskette

Following files are on the sample diskette:

- GONOGO  
GO/NO-GO sample program.
- VTH.MES  
File for setting up the 4155/4156 to measure Vth and beta.
- GM.MES  
File for setting up the 4155/4156 to measure gm.
- RDS.MES  
File for setting up the 4155/4156 to measure Rds(ON).
- BVCEO.MES  
File for setting up the 4155/4156 to measure BVceo.
- ICVC.MES  
File for setting up the 4155/4156 to measure Va and Rc.
- HFE.MES  
File for setting up the 4155/4156 to measure hFE.
- RE.MES  
File for setting up the 4155/4156 to measure Re.

## Sample Devices

This sample program is for testing the following two devices:

- MOSFET (SD214DE): Agilent P/N 1855-0723
- Bipolar Transistor (2N3904): Agilent P/N 1854-0215

You can customize this sample program to suit your devices. Refer to “Customization” for details.

## Connection

Connect the 4155/4156 to the 16442A as shown below. If you use the 4156, connect triaxial cables to the Force terminals, and open the Sense terminals.

Figure 4-2

Connection between 4155 and 16442A

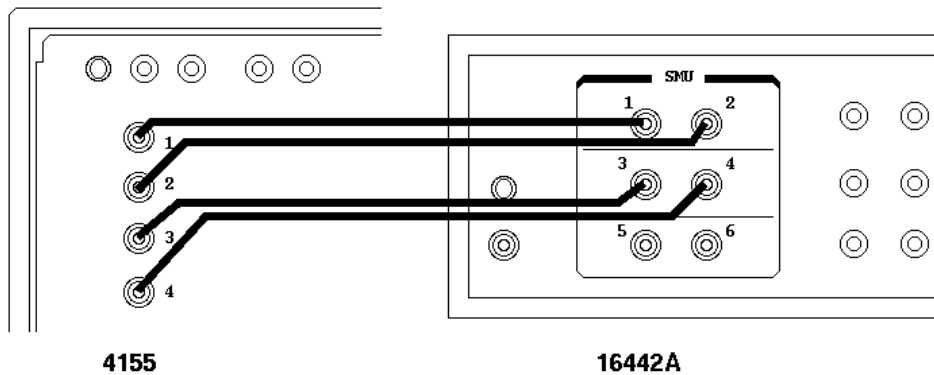

## Execution

1. Insert diskette that contains GONOGO program into built-in flexible disk drive of the 4155/4156.
2. Press the IBASIC **Display** key until All IBASIC screen is displayed. And enter the following command to get the GONOGO program.

GET"GONOGO"

3. Press **RUN** front-panel key to execute the program.
4. You need to enter supplemental information, such as "Operator name", as shown in Figure 4-3.

Type in your name, then comment as requested.

**Figure 4-3** Operator Name Input Screen

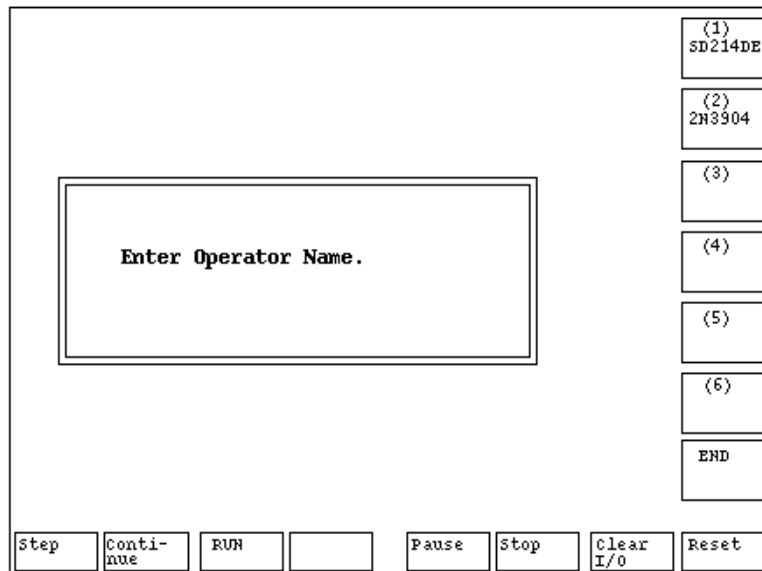

The diagram shows a terminal screen with a central text box containing "Enter Operator Name.". To the right of the screen is a vertical column of seven buttons labeled (1) through (6), with an "END" button below them. The (1) button contains "SD214DE" and the (2) button contains "2N3304". At the bottom of the screen is a horizontal row of eight buttons: "Step", "Conti-  
nue", "RUN", an empty box, "Pause", "Stop", "Clear  
I/O", and "Reset".

5. Program prompts you to select the device type from the selection menu as shown in Figure 4-4.

**Figure 4-4** Device Selection Menu

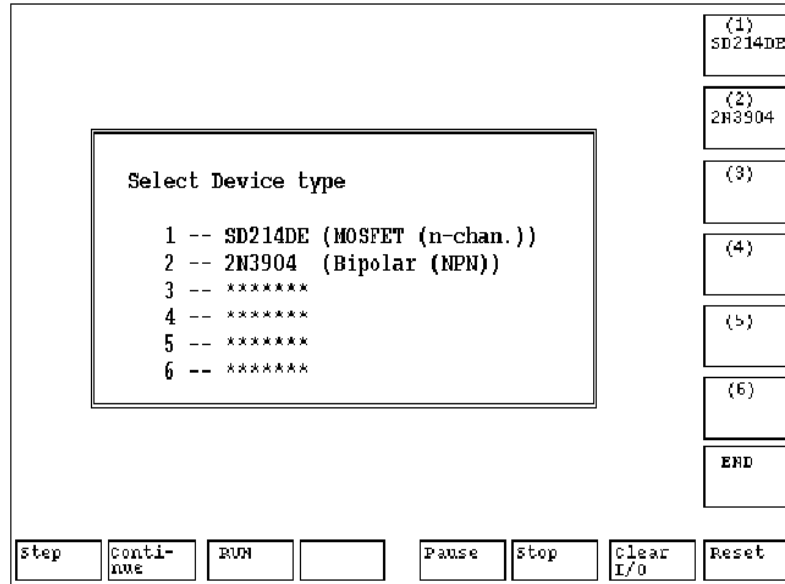

6. Select the softkey of desired device type. The following is displayed.

**Figure 4-5** Main Display

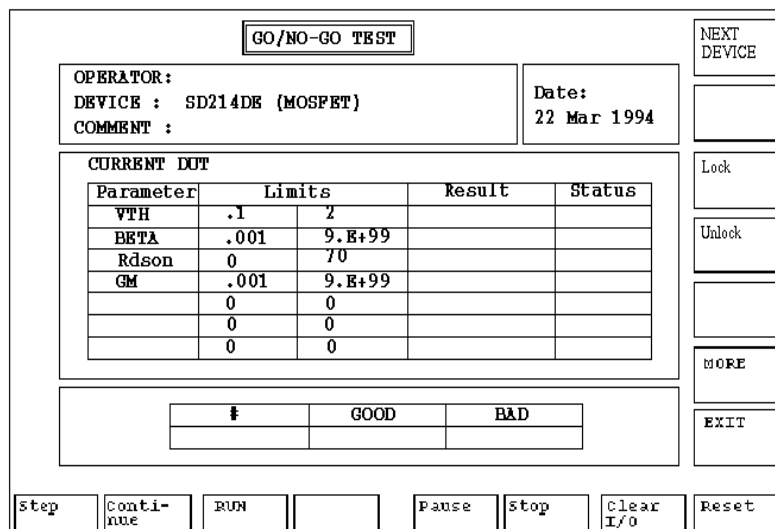

- Connect (on the 16442A test fixture) according to the device type you will use. See following figure.

Figure 4-6 Connection of Device on Test Fixture (Top View)

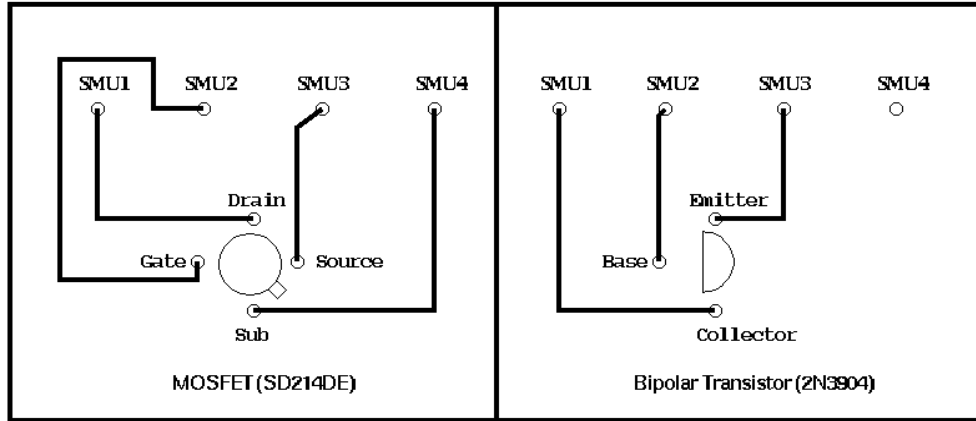

- After putting the device on the fixture, press NEXT DEVICE softkey.

The parameter extractions are performed one by one. After all the measurements are finished, results are displayed.

Each measured parameter is compared to the upper and lower limits, and judged GOOD or BAD. If all parameters are within limits, the device is judged as GOOD, so the device is ready to be shipped or to be used. If BAD, the device has some defects.

- Attach next device to the fixture, then select the NEXT DEVICE softkey.

Figure 4-7 shows an example result screen after several devices are measured.

Figure 4-7 Example Result Screen

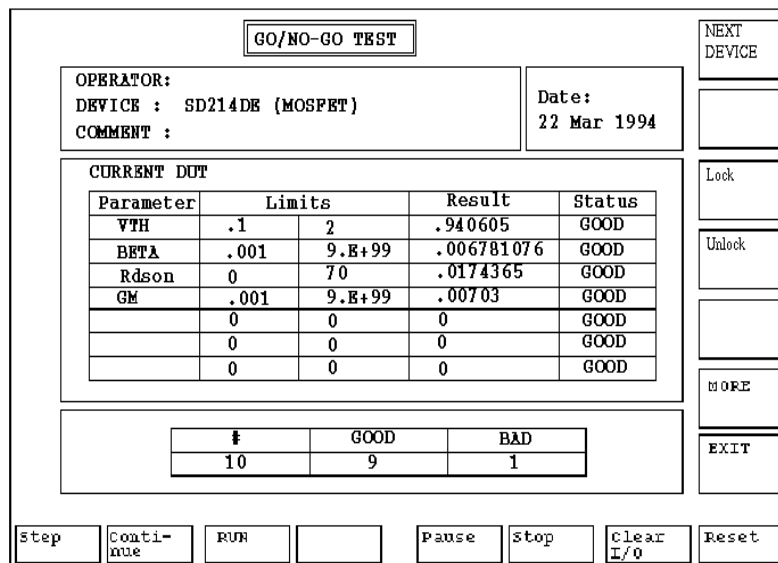

## Viewing All Curves while Measurement is in Progress

If you want to view all the measurement curves in real time while the test is in progress, select the Unlock softkey in the main display.

Figure 4-8 Unlock Function Shows Every Curve while Measurement is in Progress

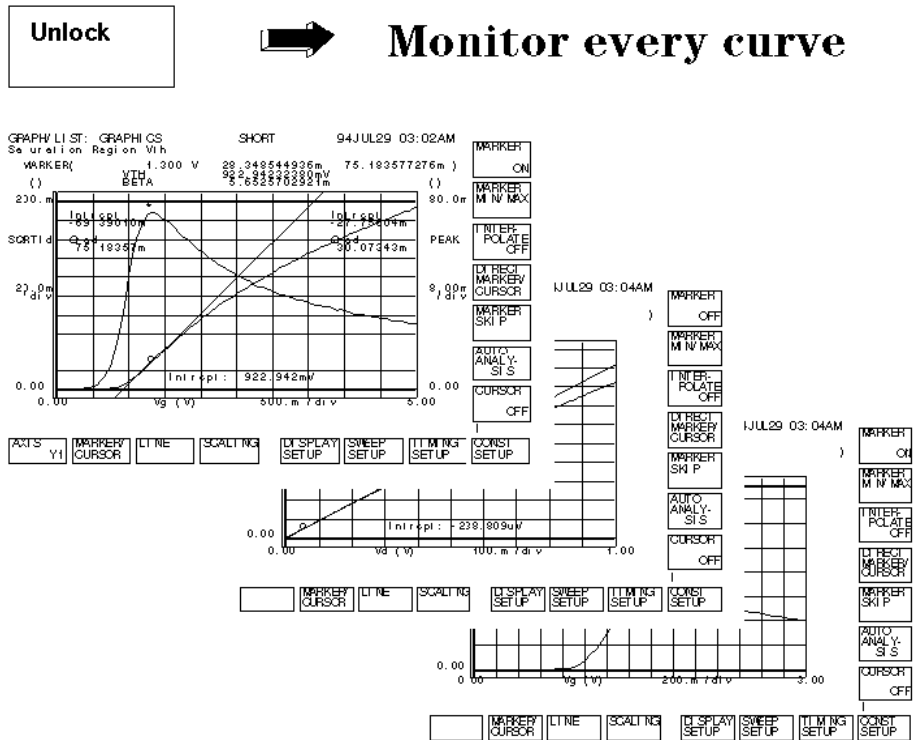

## Viewing Only Results while Measurement is in Progress

If you only want to see the measured parameter values, select Lock softkey in the main menu. Only the following screen will be displayed.

Figure 4-9 Lock Function Displays only the Status Screen



GO/NO-GO TEST												
OPERATOR:			Date:									
DEVICE : SD214DE (MOSFET)			22 Mar 1994									
COMMENT :												
CURRENT DUT												
Parameter	Limits		Result	Status								
VTH	.1	2	.940605	GOOD								
BETA	.001	9.E+99	.006781076	GOOD								
Rdson	0	70	.0174365	GOOD								
GM	.001	9.E+99	.00703	GOOD								
	0	0	0	GOOD								
	0	0	0	GOOD								
	0	0	0	GOOD								
<table border="1"> <thead> <tr> <th>#</th> <th>GOOD</th> <th>BAD</th> </tr> </thead> <tbody> <tr> <td>10</td> <td>9</td> <td>1</td> </tr> </tbody> </table>					#	GOOD	BAD	10	9	1		
#	GOOD	BAD										
10	9	1										
<table border="1"> <tr> <td>step</td> <td>Conti- nue</td> <td>RUN</td> <td></td> <td>Pause</td> <td>stop</td> <td>Clear I/O</td> <td>Reset</td> </tr> </table>					step	Conti- nue	RUN		Pause	stop	Clear I/O	Reset
step	Conti- nue	RUN		Pause	stop	Clear I/O	Reset					

## Viewing a Particular Measurement Curve

If a device is judged **BAD**, you may want to remeasure, and display only a particular measurement curve. If so, press MORE softkey, then the Monitor Curve softkey.

The softkey labels are changed to Curve curvename, where *curvename* is the name of each curve. Select the softkey for the desired curve. The measurement is performed again, and only selected curve is displayed as shown in the following example.

Figure 4-10

Monitor Curve Softkey

Monitor  
Curve



Monitor each curve

### Example

Monitor  
Curve



Curve  
Vth

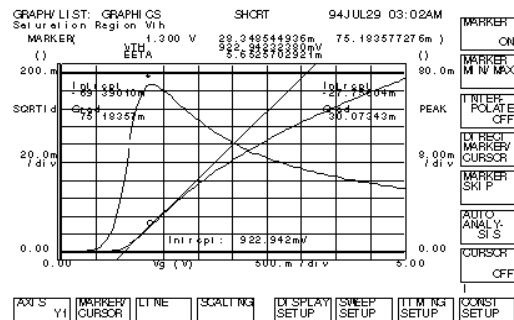

## Changing Limits

If you want to change the limit values after the program is started, select the MORE softkey, then the Change Limit softkey. Then, select the softkey for the limit value that you want to change. Type in the new value from the keyboard or front panel.

Figure 4-11

### Change Limit Softkey



CURRENT DUT				
Parameter	Limits		Result	Status
VTH	.1	2		
BETA	.001	9.E+99		
Rdsop	0	70		
Gm	.001	9.E+99		
	0	0		
	0	0		
	0	0		

Lock

Unlock

MORE

## Displaying Statistical Data

To display statistical results, such as average or standard deviation, press MORE softkey, then Statistics softkey.

Then, select the softkey of the statistical data that you want to display. The statistical data of all devices that have been measured is displayed in the Result column, and the type of statistic is displayed in the Status column.

Figure 4-12

### Statistics Softkey

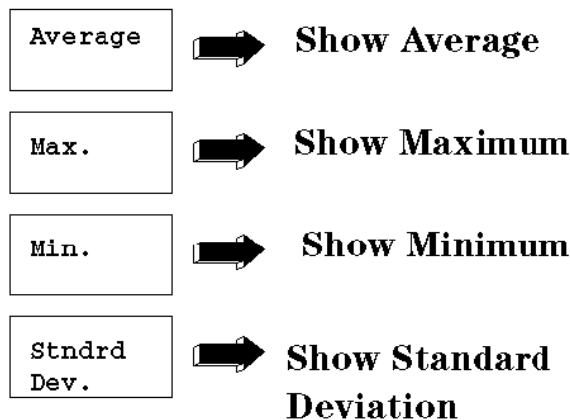
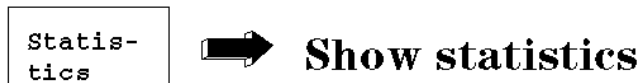

### Example

**Average**

Result	Status
.940605	Average
.006781076	Average
.0174365	Average
.00703	Average
0	Average
0	Average
0	Average

## Exporting Data to Spreadsheet

Figure 4-13 Exporting Result Data to a Spreadsheet

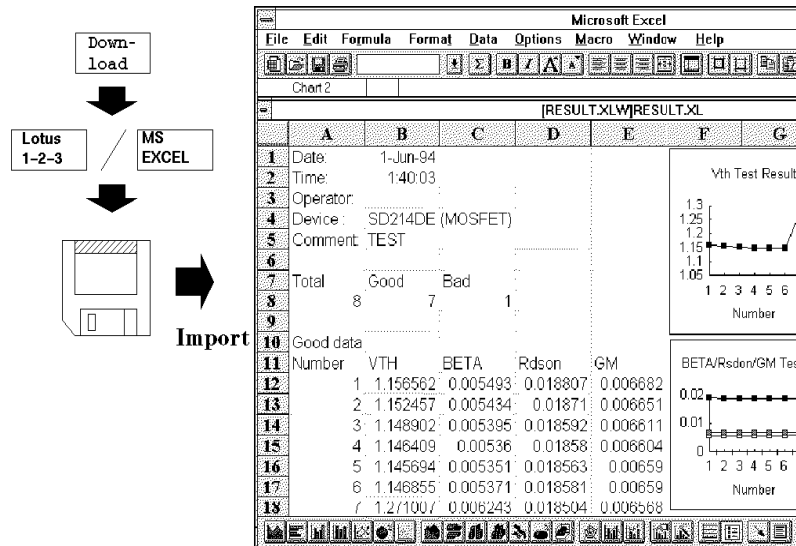

After finishing the test, you can export all the measured data to a spreadsheet as follows:

1. After all devices have been measured, select EXIT softkey on the main display.
2. Select Download, enter the desired file name, then select LOTUS 1-2-3 or MS EXCEL softkey depending on which of these spreadsheets you have.

The result data is saved to a diskette in ASCII format, which can be imported into the spreadsheet.

The following data is saved to the file on diskette:

- Date
- Time
- Operator name
- Device type
- Comment
- Number of measured devices
- Number of good devices
- Number of bad devices
- Raw measurement data
- Average
- Maximum
- Minimum
- Standard deviation

---

## Customization

This section describes how to customize the sample program to suit your test device.

Also, this section describes how to customize the sample program for use with a handler.

### Overview

Customization procedure consists of following 5 steps:

1. Decide which parameters you want to measure.
2. Decide upper and lower limits of each parameter according to the device specifications.
3. Create a 4155/4156 measurement setup file for each parameter.
4. Edit the Select\_dut subprogram in GONOGO program.
5. Edit the Dut\_spec subprogram in GONOGO program.

The following describes each of these steps:

#### To Decide Parameters to Measure

Decide which parameters you need to extract as shown in the following example for a MOSFET:

- Vth
- gm
- BVdss
- Rds(ON)

#### To Decide Lower and Upper Limits for Each Parameter

Decide the upper and lower limits of each parameter as shown in following example for a MOSFET:

Parameter	Lower Limit	Upper Limit
Vth	0.2	2.5
Gm	0.001	90
BVdss	40	9.E+99
Rds(ON)	.001	9.E+99

Write down the values. You will enter these values in the program as described in step 5.

---

**NOTE**

If you don't need to specify an upper limit or lower limit, assign a dummy value. For upper limit, the dummy value could be 9.E+99. For lower limit, it could be -9.E+99



Figure 4-16

**SWEEP SETUP Page**

MEASURE: SWEEP SETUP 94AUG09 02:46AM

Saturation Region Vth

* VARIABLE	VAR1	VAR2
UNIT	SMU2:HR	
NAME	Vg	
SWEEP MODE	SINGLE	
LIN/LOG	LINEAR	
START	0.0000 V	
STOP	5.000 V	
STEP	50.0mV	
NO OF STEP	101	
COMPLIANCE	100.00mA	
POWER COMP	OFF	

\*TIMING

HOLD TIME	0.0000 s
DELAY TIME	0.0000 s

\*SWEEP CONTINUE AT ANY Status

\*CONSTANT

UNIT	SMU1:HR	SMU4:HR		
NAME	Vd	Vsb		
MODE	V	V		
SOURCE	5.000 V	0.0000 V	.....	.....
COMPLIANCE	100.00mA	100.00mA	.....	.....

SINGLE

Select Sweep Mode with softkey or rotary knob.

SWEEP SETUP		MEASURE SETUP	OUTPUT SEG			PREV PAGE	NEXT PAGE
-------------	--	---------------	------------	--	--	-----------	-----------

Figure 4-17

**DISPLAY SETUP Page**

DISPLAY: DISPLAY SETUP 94AUG09 02:47AM

Saturation Region Vth

\*DISPLAY MODE

GRAPHICS

\*GRAPHICS

	Xaxis	Y1axis	Y2axis
NAME	Vg	SORTID	GRAD
SCALE	LINEAR	LINEAR	LINEAR
MIN	0.00000000 V	0.000000000	0.000000000
MAX	5.00000 V	200.00000000m	60.000000000m

\*GRID ON

\*LINE PARAMETER ON

\*DATA VARIABLES

VTH

BETA

GRAPHICS

Select Display Mode with softkey or rotary knob.

DISPLAY SETUP	ANALYSIS SETUP					PREV PAGE	NEXT PAGE
---------------	----------------	--	--	--	--	-----------	-----------

Figure 4-18

**ANALYSIS SETUP Page**

DISPLAY: ANALYSIS SETUP 94AUG09 02:47AM

Saturation Region Vth

\*LINE1: [TANGENT ] line on [Y1] at a point where [GRAD ] = [MAX(GRAD)]

\*LINE2: [ ]

\*MARKER: At a point where [GRAD ] = [MAX(GRAD)]

\*Interpolate: [OFF]

Switch Sweep On/Off with switche or rotary knob.

DISPLAY SETUP	ANALYSIS SETUP					PREV PAGE	NEXT PAGE
---------------	----------------	--	--	--	--	-----------	-----------

## To Edit Select\_dut Subprogram

Add the device type to the program by editing the `Select_dut` subprogram.

In the IBASIC editor, enter the following command. And edit the subprogram.

```
EDIT Select_dut
```

## Adding Device Type to Selection Menu.

To add the device type, you need to modify one of the following lines:

```
9380 PRINT TABXY(13,13);"2 -- 2N3904 (Bipolar (NPN))"  
9390 PRINT TABXY(13,14);"3 -- *****" !for future enhancement###  
9400 PRINT TABXY(13,15);"4 -- *****" !for future enhancement###
```

For example, modify line 9390 as follows:

```
9380 PRINT TABXY(13,13);"2 -- 2N3904 (Bipolar (NPN))"  
9390 PRINT TABXY(13,14);"3 -- 2N4351 (MOSFET (npn))"  
9400 PRINT TABXY(13,15);"4 -- *****" !for future enhancement###
```

## Setting the Device Type Flag.

The device type you select is passed to the other subprograms via the `Dut_flag` flag.

You need to modify following part of the `Select_dut` subprogram. The following shows the original subprogram.

```
9470 ON KEY 2 LABEL " (2) 2N3904 " GOTO Dut2  
9480 ON KEY 3 LABEL " (3) " GOTO End  
9490 ON KEY 4 LABEL " (4) " GOTO End  
:  
:  
9690 Dut3: !  
9700 Dut_flag=3  
9710 Dname$=""  
9720 GOTO Exit
```

In this example, we will modify lines 9480 and 9710 as follows:

```
9470 ON KEY 2 LABEL " (2) 2N3904 " GOTO Dut2  
9480 ON KEY 3 LABEL " (3) 2N4351 " GOTO End  
9490 ON KEY 4 LABEL " (4) " GOTO End  
:  
:  
9690 Dut3: !  
9700 Dut_flag=3  
9710 Dname$="2N4351 (MOSFET)"  
9720 GOTO Exit
```

Parameter `Dname$` is passed to the other subprograms as the name of the device.

## To Edit Dut\_spec Subprogram

The Dut\_spec subprogram sets the following for your device: parameter names, limits of each parameter, the name of the 4155/4156 measurement setup file to extract the parameter, and unit of each parameter.

In the IBASIC editor, enter the following command. And edit the subprogram:

```
EDIT Dut_spec
```

This subprogram has a SELECT Dut\_flag statement, which executes the CASE statement according to the Dut\_flag flag value. The Dut\_flag value was set by the Select\_dut subprogram according to the device you selected by softkey.

You need to add a "CASE" statement for your device just before the "CASE ELSE" statement.

For example, insert "CASE 3" just before the "CASE ELSE" statement as follows:

```
2630      M_file$(7)=""
2640      !
2641      CASE 3
2650      CASE ELSE
```

The "3" corresponds to the "2N4351 (MOSFET)", which you set in the Select\_dut subprogram as described in the previous section.

You set the parameter names in the Par\$(i) variables (maximum 9 characters). You can set up to seven parameter names.

---

**NOTE**

This parameter name must correspond to the measurement setup file assigned to M\_file\$(i). For example, if Par\$(1)="VTH", the setup file for measuring VTH must be specified for M\_file\$(1). This measurement setup file was created as described in "To Create the Measurement Setup Files".

The variable for the upper limit of the parameter is Par\_lmx(i).

The variable for the lower limit of the parameter is Par\_lmn(i).

The variable for the unit of the parameter is Par\_lu\$(i), maximum 1 character.

The variable for the setup file name is M\_file\$(i), maximum 10 characters.

---

**NOTE**

This file name must correspond to parameter assigned to Par\$(i). For example, if Par\$(1)="VTH", the setup file for measuring VTH must be specified for M\_file\$(1). This measurement setup file was created as described in "To Create the Measurement Setup Files".

### Example Modification.

Following is an example modification. If you do this modification which inserts lines 2641 to 2681, program line numbers 2650, 2660, 2670, and 2680 of original program will automatically shift to 2683, 2684, 2685, and 2686, respectively.

```
2640 !
2641 CASE 3
2642     Par$(1)="VTH"      !parameter names
2643     Par$(2)="GM"
2644     Par$(3)="BVdss"
2645     Par$(4)="Rdson"
2646     Par$(5)=""
2647     Par$(6)=""
2648     Par$(7)=""
2649 !
2650     Par_lmx(1)=2.5    !parameter spec max limit
2651     Par_lmx(2)=90
2652     Par_lmx(3)=9.E+99
2653     Par_lmx(4)=9.E+99
2654     Par_lmx(5)=0
2655     Par_lmx(6)=0
2656     Par_lmx(7)=0
2657 !
2658     Par_lmn(1)=.2     !parameter spec min limit
2659     Par_lmn(2)=.001
2660     Par_lmn(3)=40
2661     Par_lmn(4)=.001
2662     Par_lmn(5)=0
2663     Par_lmn(6)=0
2664     Par_lmn(7)=0
2665 !
2666     Par_lu$(1)="V"
2667     Par_lu$(2)="S"
2668     Par_lu$(3)="V"
2669     Par_lu$(4)="O"
2670     Par_lu$(5)=""
2671     Par_lu$(6)=""
2672     Par_lu$(7)=""
2673 !
2674     M_file$(1)="EXVTH.MES"
2675     M_file$(2)="EXGM.MES"
2676     M_file$(3)="EXBV.MES"
2677     M_file$(4)="EXRDS.MES"
2678     M_file$(5)=""
2679     M_file$(6)=""
2680     M_file$(7)=""
2681 !
2683 CASE ELSE
```

## Hints to Use with Handler

If you want to use the sample program with a handler, insert the control routine for the handler as described in the following:

### Mounting the DUT

When NEXT DEVICE softkey is selected in main screen, the program jumps to the `Next_device` label (line 4040).

Measurement parameter extraction starts from line 4130. Insert the handler control routine between lines 4120 and 4130.

### Sorting the DUT

The measured data is compared to the upper and lower limits in the `Check_data` subprogram. The result is returned to the `Flag` parameter. If measured data is within specification, "0" is returned. If out of the specification, "1" is returned.

The `Check_data` subprogram is called at line 4740.

If you want to sort the device using handler, put the control routine for sorting just after line 4740 referring to the value of `Flag`.

Go/NO-GO  
Customization

---

---

**5 HCl Degradation Test**

---

## HCI Degradation Test

Hot-carrier-induced (HCI) degradation of MOSFET parameters is an important reliability concern in modern microcircuits.

This operation manual describes a sample HCI degradation test program and data analysis program running on the 4155/4156, and how to use and customize the programs. The programs are written in the Instrument BASIC (IBASIC), and are ready to run on the built-in IBASIC controller of the 4155/4156.

“Hot-Carrier-Induced (HCI) Degradation Test” describes basic theory, procedure, and terminology of the HCI degradation test.

“HCI Degradation Test Data Analysis” describes the HCI degradation test data analysis procedure.

“Basic Operation” describes the HCI degradation test methodology using the 4155/4156, how to execute the sample programs, and program overview.

“Customization” describes the customization procedure. This procedure is very important because you probably need to modify the programs to suit your test device.

“Setup Files” shows the 4155/4156 page settings that are stored in the setup files.

## Hot-Carrier-Induced (HCI) Degradation Test

This section describes the Hot-Carrier-Induced Degradation measuring procedure (based on the proposed JEDEC 29-JULY-93 standard) and related terminology.

Hot-carriers are generated in the MOSFET by large electric fields in channel near the drain region. Hot-carriers break bonds at the Si/SiO<sub>2</sub> interface and can be also trapped in the SiO<sub>2</sub>. The trapping or bond breaking creates interface traps and oxide charge that affect the channel carrier's mobility, and the effective channel potential. Interface traps and oxide charge affect transistor performance. The common method to identify performance degradation is to monitor parameters such as threshold voltage, transconductance, and drain current.

Generally n-channel MOSFETs have the greatest susceptibility. Therefore this manual describes an accelerated test for measuring the hot-carrier-induced degradation of an n-channel MOSFET under DC bias.

### Overview

Figure 5-1 shows the flow of the HCI degradation test according to the JEDEC proceeding titled "A PROCEDURE FOR MEASURING HCI" (29-JULY-93).

**Figure 5-1** HCI Degradation Test Algorithm Flow

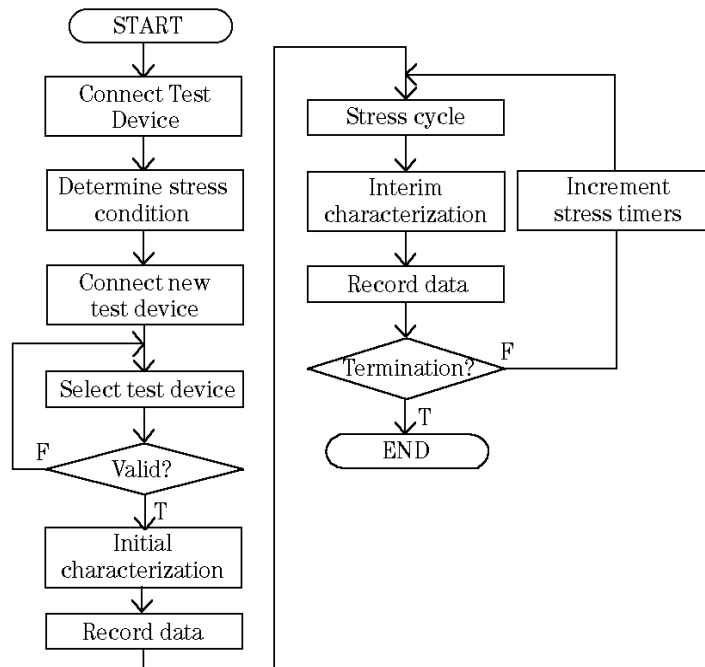

First, a test device is used to determine the stress bias conditions. After that, other test devices are connected and judged to be valid or not by measuring the gate, drain, and source leakage currents.

---

**NOTE**

---

The test device used to determine the stress bias conditions should not be used for hot-carrier stress testing.

For test devices that have all leakage currents within limits, initial characterization is performed, which measures and records the initial  $I_{dlin}$ ,  $G_{mmax}$ ,  $V_{text}$ , and  $V_{tci}$  parameters. Then, the stress/interim characterization loop is performed, which does the following:

1. During the stress cycle, the devices are biased using the previously determined stress bias conditions.
2. After each stress cycle, the device parameters are again measured, recorded and compared to the initial values.
3. If the parameter values have degraded past the limits, testing ends. Otherwise, another stress cycle is performed.

## Determining Stress Bias Conditions

Hot-carrier stressing should be performed under constant voltage bias conditions as follows (you use a test device to determine the appropriate drain and gate bias voltages):

- Source voltage should be set to 0 V.
- Bulk voltage should be set to nominal bulk supply voltage of the technology ( $V_{bb}$ ).
- (Recommended) Maximum drain stress bias voltage should be about 0.5 V below actual breakdown.
- For the selected drain bias condition, the corresponding gate bias should be set to induce the maximum possible bulk current. Peak  $I_b$  gate biasing typically results in the greatest rate of n-channel MOSFET degradation.

## Selecting Test Devices

Before starting the stress cycle, select only devices that have gate, drain, and source leakage currents that are within desired limits. For the stress cycle, do not use the test device that was used to determine the stress bias conditions.

## Initial Characterization

All parameters ( $I_{dlin}$ ,  $G_{mmax}$ ,  $V_{text}$ , and  $V_{tci}$ ) are determined for the selected devices, and these parameter values are recorded as the initial parameter values.

## Parameter Definitions

Following describes the parameters measured in the HCI degradation test program, and analyzed in the HCI degradation Data Analysis program.

### Linear Drain Current (*Idlin*)

The linear drain current is measured under the following conditions:

**Drain voltage Vd:** 0.1 V

**Gate voltage Vg:** Vdd

**Source voltage Vs:** 0 V

**Bulk voltage Vb:** Vbb

Vdd and Vbb are nominal drain and bulk voltages for the technology.

### Maximum Linear Transconductance (*Gmmax*)

The maximum linear transconductance is defined as the maximum slope of the Id-Vg curve. The Id-Vg characteristics are obtained by sweeping gate voltages under the following conditions:

**Drain voltage Vd:** 0.1 V

**Source voltage Vs:** 0 V

**Bulk voltage Vb:** Vbb

The gate voltage is varied in increments of 20 mV or less, starting from below the turn-on voltage and increasing to a value that is large enough to ensure that the maximum slope point is reached.

### Extrapolated Threshold Voltage (*Vtext*)

This parameter is obtained by measuring the drain current (*Id*) while sweeping the gate voltage (*Vg*). *Vtext* is calculated according the following equation:

$$V_{text} = V_g(G_{mmax}) - I_d(G_{mmax}) / G_{mmax}$$

$V_g(G_{mmax})$  is the gate voltage at the point where the slope of the Id-Vg curve is maximum.

$I_d(G_{mmax})$  is the drain current at the point of the maximum slope of the Id-Vg curve.

Vd is 0.1 V.

### Constant Current Threshold Voltage (*Vtci*)

The constant current threshold voltage is defined as the gate voltage applied to the device during the Id-Vg measurement where the drain current is equal to 1  $\mu$ A times the ratio of drawn gate width (W) to drawn gate length (L).

$$V_{tci} = V_g (@I_d=1\mu A * W/L)$$

## Stress Cycle

The transistor will be stressed with the voltages described previously in “Determining Stress Bias Conditions”. The stress voltages should be applied in the following order:

- 1:Vs
- 2:Vb
- 3:Vg
- 4:Vd

Turning off the bias shall be done in the reverse order. The minimum recommended stress intervals are *one-half* decade time-steps since the typical degradation follows a power-law with time.

## Interim Characterization

All parameters ( $I_{dlin}$ ,  $G_{mmax}$ ,  $V_{text}$ , and  $V_{tci}$ ) are determined for the selected devices, and these parameter values are recorded as the interim parameter values.

## Stress Termination

Stress is terminated when one of following occurs:

- At least one parameter among  $I_{dlin}$ ,  $G_{mmax}$ ,  $V_{text}$ , or  $V_{tci}$  reaches the limit values described below in “Time to Target ( $T_{dc}$ )”.
- Total stress time reaches 100,000 sec.

## Time to Target ( $T_{dc}$ )

For  $I_{dlin}$  or  $G_{mmax}$  parameter,  $T_{dc}$  is determined as the stress time at which the parameter has changed by 10 % from its unstressed value.

For  $V_{text}$  or  $V_{tci}$  parameter,  $T_{dc}$  is the stress time at which the parameter has changed by 20 mV from its unstressed value.

## Precautions

### Test Devices

Unstressed devices must be used in hot-carrier stress testing. Pre-stressed devices can have a  $T_{dc}$  that is much different from unstressed devices.

### Interim Measurement

The devices under test may experience parameter recovery, so the parameter measurements should be made as soon as possible after each stress cycle.

## Technical Requirements

### Equipment Requirements

- The measurement system must be able to measure a minimum of 1 nA. The overshoot must not exceed 1 % of applied voltage.
- To determine  $V_{tci}$ , the measurement system must have at least 2 mV resolution for  $V_g$  step. If the  $V_g$  step size is larger than 2 mV, an interpolation method may be used to achieve the 2 mV resolution.

### Measurement Requirements

- The temperature of the wafer chuck or the temperature of the test fixture must be controlled to a temperature of  $22\text{ }^{\circ}\text{C} \pm 3\text{ }^{\circ}\text{C}$ .
- The stress time interval should be known to an accuracy of  $\pm 3\%$ .

## HCI Degradation Test Data Analysis

This section describes the Data Analysis procedure to determine Time to Target ( $T_{dc}$ ) after Hot-Carrier-Induced Degradation test, which is based on the proposed JEDEC 29-JULY-93 standard.

Figure 5-2 shows the flow of the HCI degradation data analysis according to the JEDEC proceeding titled "A PROCEDURE FOR MEASURING HCI" (29-JULY-93).

Figure 5-2 Data Analysis Algorithm Flow

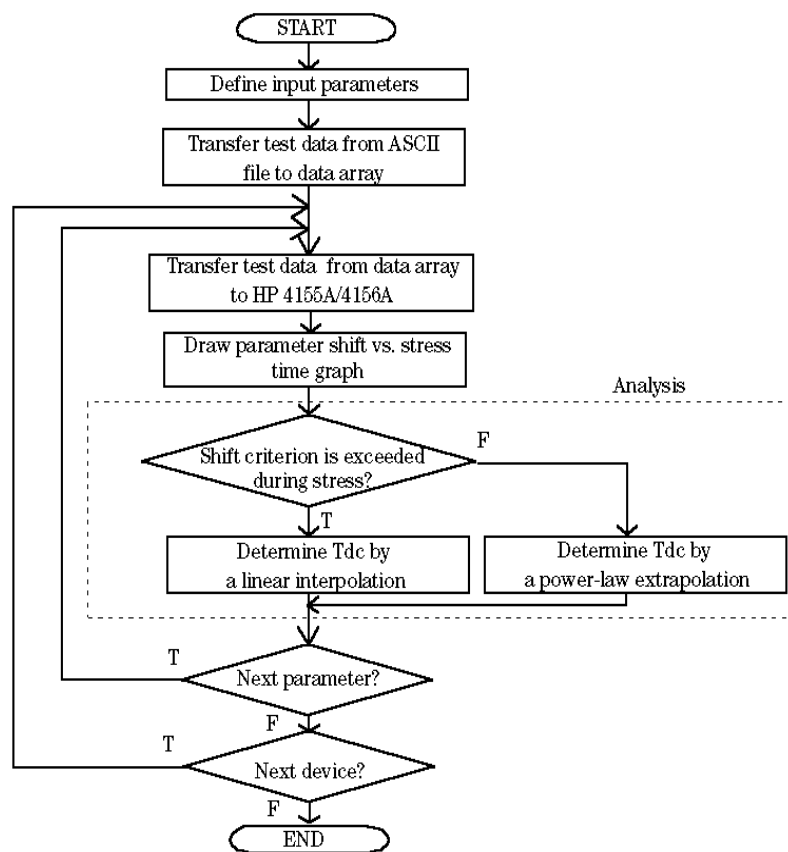

- Percent change for  $I_{dlin}$  and  $G_{max}$  is calculated as follows:

Example for  $I_{dlin}$

$$I_{dlinshift}(t) = (I_{dlin}(t) - I_{dlin}(init)) / I_{dlin}(init) * 100$$

- $I_{dlinshift}(t)$  is the percent change at stress time  $t$
  - $I_{dlin}(init)$  is the initial  $I_{dlin}$  value
  - $I_{dlin}(t)$  is the  $I_{dlin}$  value at stress time  $t$
- Relative shift for  $V_{text}$  and  $V_{tci}$  is calculated as follows:

Example of  $V_{text}$

$$V_{textshift}(t) = V_{text}(t) - V_{text}(init)$$

- $V_{textshift}(t)$  is the relative shift at stress time  $t$
- $V_{text}(init)$  is the initial  $V_{text}$  value
- $V_{text}(t)$  is the  $V_{text}$  value at stress time  $t$

The simple theory of hot-carrier degradation assumes that the degradation follows a power law with stress time. That is, the change in a parameter versus stress time is a straight line on a log-log plot.

The absolute value of change for each parameter should be fit to the following equation by using the least-squares fit:

Example for  $I_{dlin}$

$$|I_{dlinshift}(t)| = Ct^n$$

where  $|I_{dlinshift}(t)|$  is the absolute value of change in  $I_{dlin}$  and  $t$  is the cumulative stress time.  $C$  is the absolute value of change in  $I_{dlin}$  when  $t$  is 1, and  $n$  is the slope of the least-square fit line.

$T_{dc}$  for each parameter should be *interpolated* or *extrapolated* from the data based on the  $C$  and  $n$  values from this least-squares fit. See the following two figures.

**Figure 5-3** Example Extrapolation of HCI Degradation Data

If the shift criterion is *not* exceeded, *extrapolation* should be used based on the last two time decades as shown in following example.

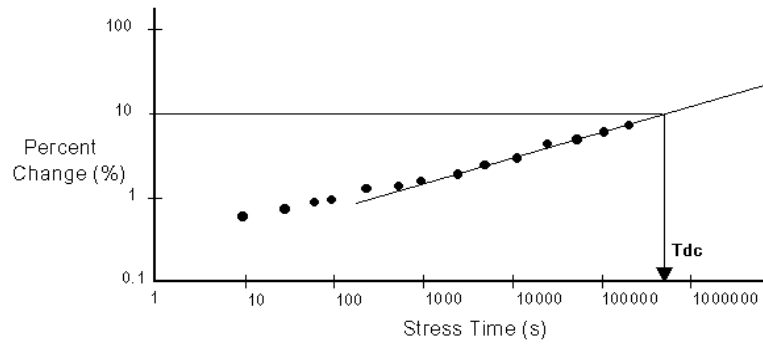

**Figure 5-4** Example Interpolation of HCI Degradation Data

If the shift criterion is exceeded,  $T_{dc}$  should be determined by using a linear *interpolation* between the two data points as shown in following example.

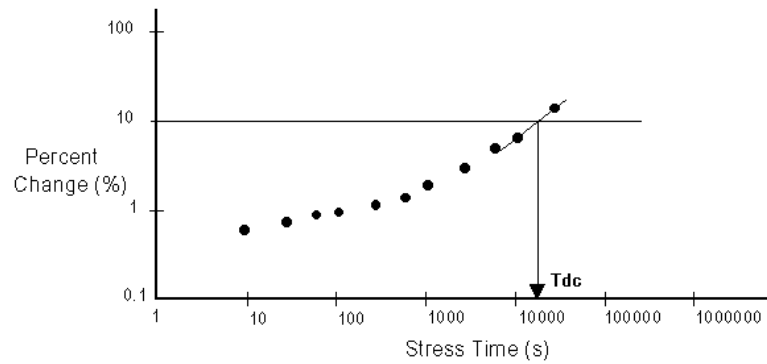

## Basic Operation

This section describes how to use the 4155/4156 to perform HCI degradation test and data analysis: methodology, input parameters, HCI degradation test, data analysis, required equipment, files on diskette, execution, and overview of sample programs.

### Methodology

The HCI degradation can be evaluated by executing the HCI degradation test sample program (DCDAHC), then the data analysis sample program (ANALYSIS). These programs are included on the sample software diskette.

These programs can run on the built-in IBASIC controller of the 4155/4156. Or you can modify the sample program to run on an external controller that supports HP BASIC or Instrument BASIC. Refer to “Customization” on how to modify the program to run on an external controller.

The programs load measurement setup files into the 4155/4156 internal memory. The setups are previously saved in measurement setup files on the diskette. If you need to modify the setups, get them and modify them in fill-in-the-blank manner from the 4155/4156 front panel, then re-save to the file.

The DCDAHC program displays the measurement data (Parameter shift versus Stress time) on the GRAPHICS page of the 4155/4156, and stores data in ASCII files.

The DCDAHC program can perform multiple test device evaluation by using Agilent 4085M switching matrix. Figure 5-5 shows the HCI degradation test flow for multiple device evaluation. To use another switching matrix or to not use any switching matrix, you need to modify the program as described in “Customization”.

The ANALYSIS program analyzes the measurement data (ASCII files that are saved by the DCDAHC program) to determine the time to target (Tdc).

### Input Parameters

Table 5-1 and Table 5-2 show the input parameters required for the HCI degradation test program (DCDAHC) and the HCI degradation data analysis program (ANALYSIS). You can define these parameters by editing sample program in advance.

Figure 5-5 HCI Degradation Test Algorithm Flow for Multiple Devices

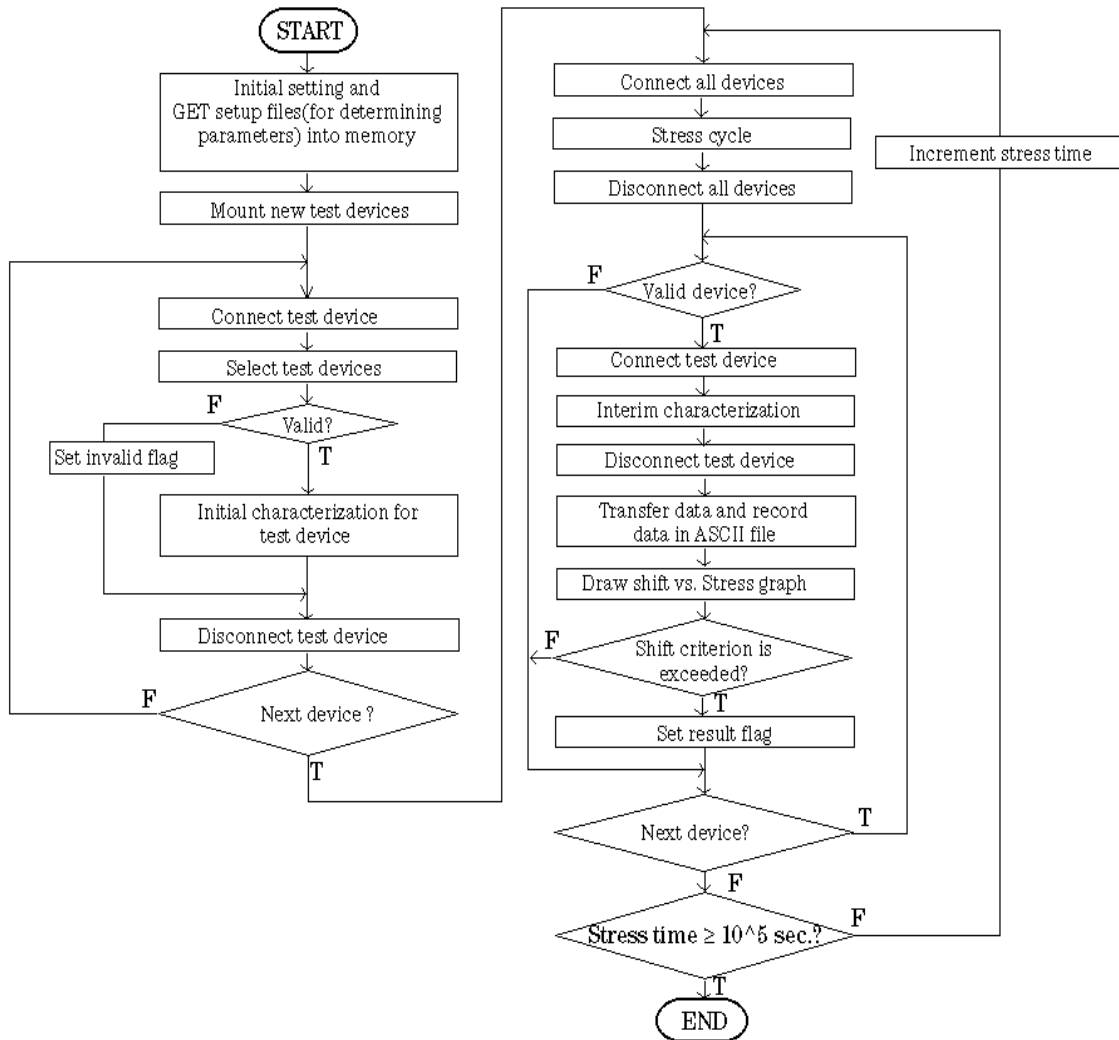

**Table 5-1 Input Parameters for HCI Degradation Test Program (DCDAH)**

<b>Parameter Name</b>	<b>Description</b>
Hpib_sc	GPIB select code for controlling 415X
Hpib_addr	GPIB address of 415X
Swm	GPIB select code and address of switching matrix controller
No_of_devices	Total number of test devices
Meas_points	Total number of interim characterization points
Igleak_max	Upper limit of the gate leakage current
Idleak_max	Upper limit of the drain leakage current
Isleak_max	Upper limit of the source leakage current
Vdstr	Drain stress voltage
Vgstr	Gate stress voltage
Vdd	Nominal drain voltage
Vbb	Nominal bulk voltage
Gate_length	Drawn gate length
Gate_width	Drawn gate width
Source_str	Source pin assignment of device used to determine stress conditions
Gate_str	Gate pin assignment of device used to determine stress conditions
Drain_str	Drain pin assignment pin of device used to determine stress conditions
Bulk_str	Bulk pin assignment of device used to determine stress conditions
Source(*) <sup>a</sup>	Source pin assignment of device to stress/measure
Gate(*) <sup>a</sup>	Gate pin assignment of device to stress/measure
Drain(*) <sup>a</sup>	Drain pin assignment of device to stress/measure
Bulk(*) <sup>a</sup>	Bulk pin assignment of device to stress/measure
Ibvg_file\$	Ib-Vg measurement setup file used to determine Vgstr
Igleak_file\$	Ig-time measurement setup file to check gate leakage
Idleak_file\$	Id-time measurement setup file to check drain leakage
Isleak_file\$	Is-time measurement setup file to check source leakage
Str_file\$	Stress setup file
Param_file\$	Parameter measurement setup file

<b>Parameter Name</b>	<b>Description</b>
Idlin_data\$	ASCII file of Idlin shift data
Gmmax_data\$	ASCII file of Gmmax shift data
Vtext_data\$	ASCII file of Vtext shift data
Vtci_data\$	ASCII file of Vtci shift data
Meas_str_time	Stress duration data
Show_device	Flag to specify the devices for which you want to display parameter shift graphs (All=0 or Device No.)
Show_param	Flag to specify parameters for which you want to display parameter shift graphs (All=0, Idlin=1, Gmmax=2, Vtext=3, Vtci=4, -1=No graphs)
Save_at_last	Flag to specify when to save ASCII data files (Save after each interim test=0, Save all ASCII files after completing test=1)

a. \* is device number.

**Table 5-2**

**Input Parameters for HCI Degradation Data ANALYSIS Program**

<b>Parameter Name</b>	<b>Description</b>
No_of_devices	Number of devices to analyze
Pause_to_save	Flag to specify whether to pause after drawing each "parameter shift vs stress time" graph so that you can save to a DAT file. (Pause: 1, No pause: 0)
Idlin_data\$	ASCII file of Idlin shift data
Gmmax_data\$	ASCII file of Gmmax shift data
Vtext_data\$	ASCII file of Vtext shift data
Vtci_data\$	ASCII file of Vtci shift data
Save_file\$	ASCII file in which to save averaged Tdc data

## HCI Degradation Test

### Determining Stress Bias Conditions

Stress voltages should be forced to the devices under the following conditions with specified temperature:

**Source stress voltage  $V_s$ :** 0 V

**Bulk stress voltage  $V_b$ :**  $V_{bb}$  (= 0 V)

Before executing the DCDAHC program, you should determine the drain stress voltage ( $V_{dstr}$ ) by performing the Id-Vd measurement. The Id-Vd measurement setup is in the IDVD.MES file on the diskette. It is recommended that the maximum drain stress bias voltage is about 0.5V below actual breakdown. According to the measurement result, modify the value of  $V_{dstr}$  in the DCDAHC program before execution.

The DCDAHC program determines the gate stress voltage ( $V_{gstr}$ ) by the Ib-Vg curve. The Ib-Vg setup is in the IGVG.MES file on the diskette. The sample program (DCDAHC) loads this setup into the 4155/4156 at the beginning of the measurement, and sets the specified  $V_{dstr}$ . Ib-Vg measurement is performed and the gate stress voltage ( $V_{gstr}$ ) is determined. Both  $V_{dstr}$  and  $V_{gstr}$  are saved to DCDAHC.STR file which is used for stress cycle.

### Selecting Test Devices

Remove the test device that was used for determining the stress conditions. Then mount unstressed test devices on the switching matrix. After mounting, valid test devices are selected according to the gate, drain, and source leakage currents.

The following setup files are copied from the diskette to internal memory to be used for selecting valid devices:

- IGLEAK.MES
- IDLEAK.MES
- ISLEAK.MES

If all leakage currents are within limits for a device, hot carrier stress testing will be performed for the device.

---

**NOTE**

---

For hot-carrier stress testing, do not use the test device that was used to determine the stress conditions.

### Initial Characterization

After selecting devices, one setup file is copied from the diskette to the 4155/4156 internal memory:

- PARAM.MES: setup file for determining Idlin, Gmmax, Vtext, and Vtci

DCDAHC program determines the *initial* Idlin, Gmmax, Vtext, and Vtci for the devices by using the above setup file. This setup file can easily be modified in fill-in-the-blank manner.

These initial measurement data (Idlin\_init, Gmmax\_init, Vtext\_init and Vtci\_init) are stored into IBASIC data arrays, and will be used to determine parameter shifts after each stress. These initial measurement data will be saved with parameter shift data into ASCII files on diskette after each interim measurement is performed.

### Stress/Interim Characterization

Stress voltage is applied to all test devices simultaneously. The stress setup is in DCDAHC .STR file. The cumulative stress time is 10, 20, 50, 100, 10000, 20000, 50000, 100000. After each of these cumulative times, the four parameters are measured for each device, then parameter shifts (Idlin\_shift, Gmmax\_shift, Vtext\_shift, and Vtci\_shift) are calculated and saved to ASCII files. This procedure is repeated until stress termination occurs for all test devices.

### HCI Degradation Data Analysis

After hot carrier stress test, Tdc can be determined by executing ANALYSIS sample program. You can specify the values of following parameters:

No\_of\_devices    No\_of\_devices: Number of devices to be analyzed  
Choice            Analysis parameter (Idlin=1, Gmmax=2, Vtext=3, Vtci=4,  
                      All parameters=0).

After analysis, ANALYSIS program calculates average of Tdc for each parameter, then saves the calculated data to an ASCII data file on the diskette.

## Required Equipment

The following are required to use the HCI degradation sample program:

- Agilent 4155 or Agilent 4156 Semiconductor Parameter Analyzer
- Agilent 4085M Switching Matrix (Agilent 4084B Switching Matrix Controller and Agilent 4085A Switching Matrix)
- Triaxial cable (4 cables)
- Test fixture for packaged device
- This operation manual
- Diskette that contains sample programs and setup files

Connect the required equipment and devices as shown in Figure 5-6 and Figure 5-7.

**Figure 5-6 DC HCI Degradation Test Equipment Connections**

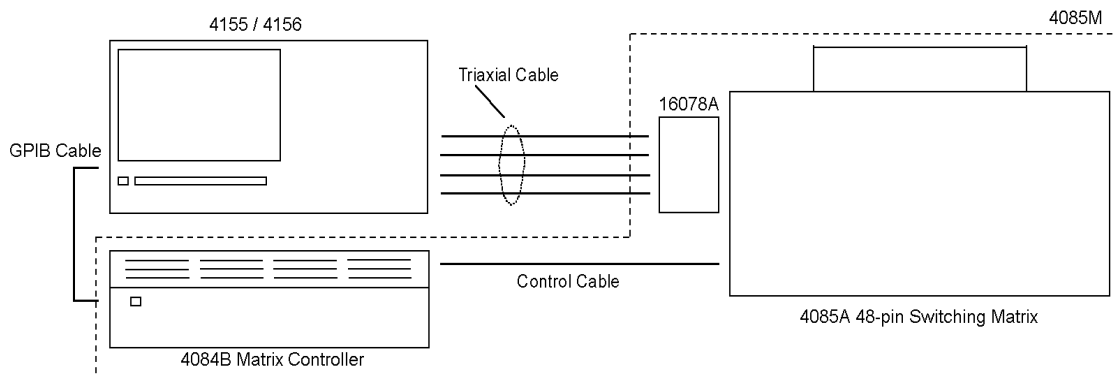

**Figure 5-7 DC HCI Degradation Test Device Connections**

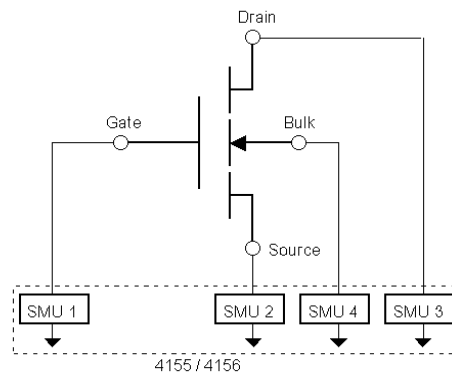

**NOTE**

If you test on a wafer, you need to have Agilent 16077A Extension Cable Fixture to connect the matrix to a prober/probe card.

If you connect multiple devices for stress forcing, your device may oscillate due to the cable impedance and characteristics of your devices. In such a case, reduce the number of devices that are connected at the same time or use shorter measurement cables.

---

**NOTE**

If you test packaged devices, you need one of the following test fixtures:

- Agilent 16067A Low Leakage Fixture (24-pin DIP)
- Agilent 16068A Low Leakage Fixture (48-pin DIP)
- Agilent 16070A General Purpose DIP Fixture
- Agilent 16071A Universal Fixture

---

**WARNING**

**Maximum output voltage is limited to 40V if you use Agilent 4085M to test on a wafer because the interlock terminal is not connected. However, you need to be careful that you don't touch the output terminals during the measurement.**

### AC Stress

If you execute AC HCI degradation test, the following are *also* required. Refer to “Performing HCI Degradation Test with AC Stress” on page 5-41 for details.

- Agilent 41501 SMU and Pulse Generator Expander furnished with 2 PGUs (Option 402, 412 or 422)
- Agilent 16440A SMU/PG Selector

### Files on the Diskette

Please make sure that following files are on the diskette.

File Name	Description
DCDAH.C	DC Drain-Avalanche HCI degradation test sample program
IDVD.MES	File for setting up the 4155/4156 to measure Id-Vd plot and determine Vdstr before running DCDAH.C program.
IBVG.MES	File for setting up the 4155/4156 to measure Ib-Vg plot and determine Vgstr
IGLEAK.MES	File for setting up the 4155/4156 to measure gate leakage current for selecting test device
IDLEAK.MES	File for setting up the 4155/4156 to measure drain leakage current for selecting test device
ISLEAK.MES	File for setting up the 4155/4156 to measure source leakage current for selecting test device
DCDAH.C.STR	File for setting up the 4155/4156 to force DC stress to test device
PARAM.MES	File for setting up the 4155/4156 to determine Idlin, Gmmax, Vtext, and Vtci after each stress
ACDAH.C.STR	File for setting up the 4155/4156 to force AC stress to test device
ANALYSIS	DC Drain-Avalanche HCI degradation test data analysis sample program

## Execution

### Before Executing HCI Degradation Test

Before executing the DCDAHC program, you must determine the drain stress voltage ( $V_{dstr}$ ) by Id-Vd measurement:

1. Connect the 4155/4156 to the 4085M switching matrix, then mount or probe the test device (that is used to determine stress conditions) on the 4085M.
2. Load the IDVD.MES setup file from the diskette into the 4155/4156, then perform the measurement. The Id-Vd measurement is displayed as shown in Figure 5-8.
3. Determine drain stress bias voltage ( $V_{dstr}$ ) from the curve. Recommended maximum value is about 0.5 V below actual breakdown.
4. Enter value for  $V_{dstr}$  in line 1900 of DCDAHC program. See “Customization” for details.

Figure 5-8

### Id-Vd Measurement Example

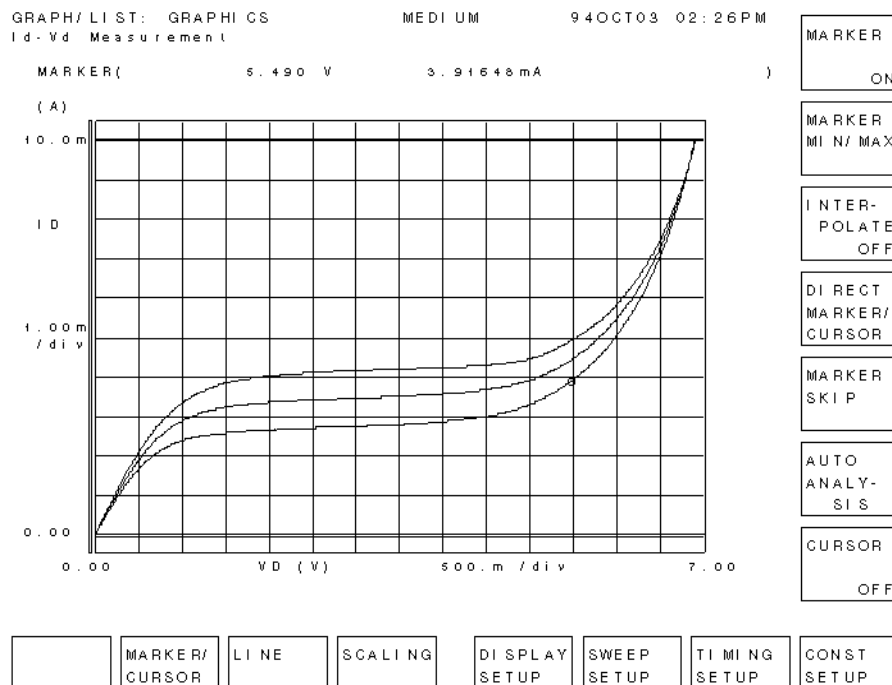

### HCI Degradation Test

1. Connect the 4155/4156 to the 4085M switching matrix. If you test packaged devices, mount necessary test fixture on the switching matrix. If you test on wafer, mount the 16077A Extension Cable Fixture and connect measurement cables to a probe card or probes on the micro manipulators.
2. Mount or probe the test device (that is used to determine stress conditions) on the 4085M.

3. Insert diskette that contains HCI degradation test sample program into the built-in drive of the 4155/4156 or drive of external controller.

- In case of using the built-in IBASIC of the 4155/4156, press the IBASIC **Display** key until All IBASIC screen is displayed. And enter the following command:

```
GET "DCDAHc"
```

- If you use an external controller on which HP BASIC is working, enter the following command:

```
GET "DCDAHc: ,msus"
```

Where *msus* is specifier of mass storage device that contains the DCDAHc program. If default *msus* is used, enter the following command:

```
GET "DCDAHc"
```

Then insert the diskette into the built-in disk drive of the 4155/4156. The diskette is used when the measurement setup files are loaded.

4. Press **RUN** front-panel key to run DCDAHc program in the 4155/4156.

To run DCDAHc program in external controller, type **RUN**, then press **Enter**.

The  $I_b$ - $V_g$  measurement is performed to determine the gate bias ( $V_{gstr}$ ) that will be used in the stress testing, then this gate bias and drain bias ( $V_{dstr}$ ) are saved to the DCDAHc.STR file.  $I_b$ - $V_g$  curve is displayed on GRAPHICS page as shown in Figure 5-9.

Figure 5-9

**Ib-Vg Measurement Example**

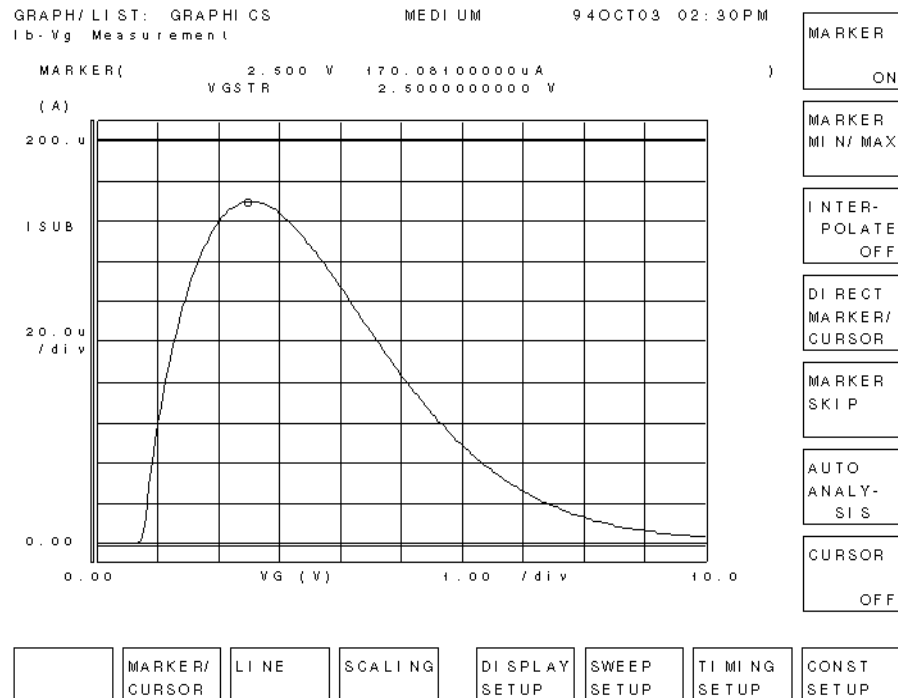

- After the message shown below is displayed, remove the device used to determine the stress conditions, then connect test devices for HCI degradation tests. Press Continue softkey to continue program. Leakage current tests are performed to select valid devices.

"Connect HCI degradation test devices"

If the device is valid, the following message is displayed.

"Device No. = XX can be used"

If the device is invalid, the following message is displayed.

"Device No. = XX shall not be used"

- The initial characterization is performed for all *valid* devices. Then stress/interim characterization loop is executed until stress termination occurs. In each interim characterization, Idlin, Gmmax, Vtext and Vtci are determined. An example measurement is shown in Figure 5-10.

**Figure 5-10 Initial/Interim Measurement Example**

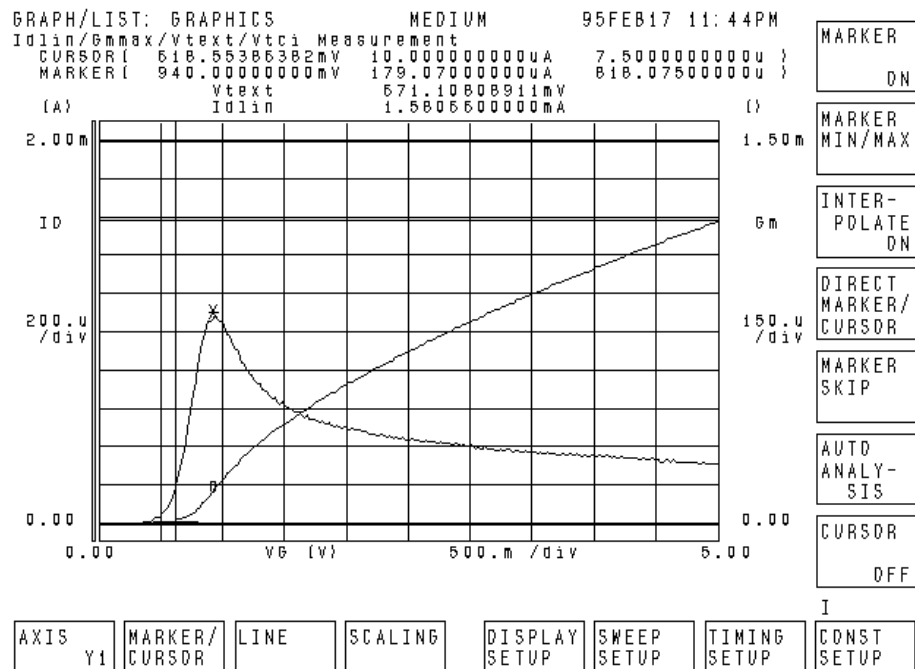



8. After testing, the following message is displayed.

```
"HCI Degradation Test is Completed!!"
```

All test data is saved to the following ASCII data files:

- IDXX: Percent change data for Idlin
- GMXX: Percent change data for Gmmax
- VTEXT: Relative shift data for Vtext
- VTIXX: Relative shift data for Vtci

(where XX = Test device number)

Each file contains following data:

- If the device is judged as valid by the leakage current tests:
  - a. Vdstr, Vgstr, Gate\_length, Gate\_width values at stress termination
  - b. Number of interim characterization points until stress termination for the device, and initial measurement data of the device
  - c. Parameter shift data for each interim characterization points until stress termination  
In case of IDXX for example, Idlin\_shift(\*) are saved.
  - d. Cumulative stress time Meas\_str\_time(\*) of interim characterization points until stress termination for the device.

The following is an example of VTEXT data file.

```
5, 1.95, 1.E-6, 1.E-5  
5, 1.094966  
.000921, .001106, .002565, .003549, .004747  
10, 20, 50, 100, 200
```

- If the device is judged as invalid by the leakage current tests:
  - a. Vdstr, Vgstr, Gate\_length, Gate\_width
  - b. 0,0

## Data Analysis

1. Insert diskette that contains ANALYSIS program and ASCII data files into built-in drive of the 4155/4156 or drive of external controller.

- To load the program into the 4155/4156, press the IBASIC **Display** key until All IBASIC screen is displayed. Then, enter the following command:

```
GET "ANALYSIS"
```

- To load the program into an external controller, enter the following command on the external controller:

```
GET "ANALYSIS: ,msus"
```

Where *msus* is specifier of mass storage device that contains the ANALYSIS program. If default *msus* is used, enter the following command:

```
GET "ANALYSIS"
```

Then insert the diskette into the built-in flexible disk drive of the 4155/4156. The diskette is used when the measurement result files are loaded.

2. Press **RUN** front-panel key to execute ANALYSIS program on the 4155/4156.

To run ANALYSIS program on external controller, type RUN, then press **Enter**.

3. Enter number of devices to be analyzed. Default number is 4.
4. Select softkey of parameter for which you want to extract Tdc.
5. Analysis result and Tdc will be displayed on GRAPHICS page of the 4155/4156 as shown in Figure 5-12. This step is repeated according to entered number of devices and selected parameters. After each graph is displayed, program pauses. During pause, you can save analyzed data to a DAT type file. To continue program, select Continue softkey.

If you don't want program to pause, change line 1740 in ANALYSIS program to `Pause_to_save=0` before you run the ANALYSIS program.

Figure 5-12 HCI Degradation Test Data Analysis Example

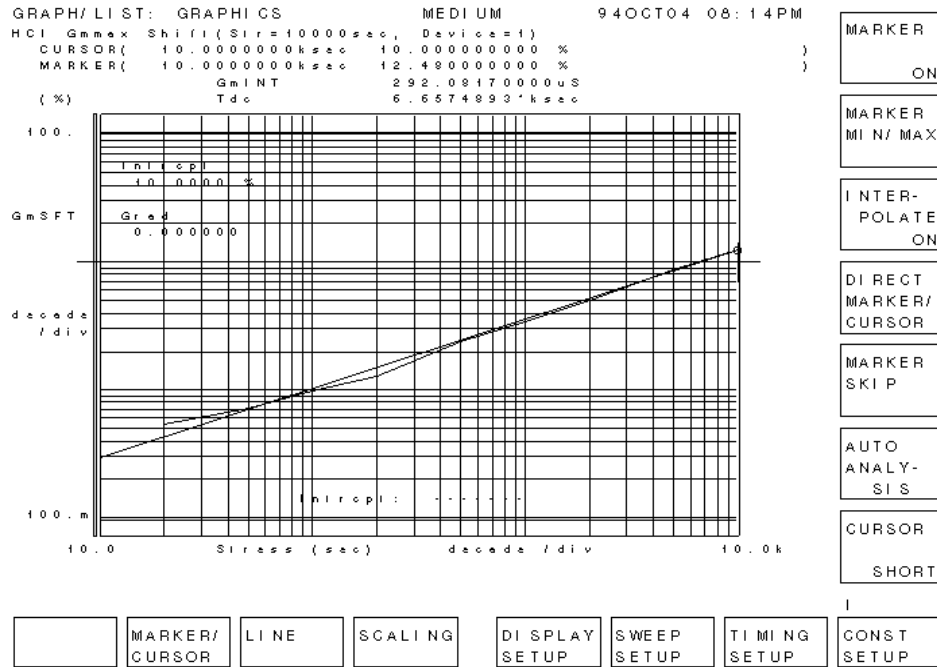

- All calculated data is saved to ANAHCI, which is an ASCII file. The data is also listed on IBASIC screen. After analyzing, saving, and listing the data, the 4155/4156 is initialized.

Following are contents of this file for the case that you selected `Idlin` parameter for the `Tdc` extraction:

- Number of devices
- `Vdstr, Vgstr, Gate width, Gate length`
- `Idlin`
- Device ,Validity ,`Tdc_idlin`  
*First device number, 0 or 1 (valid: 0, invalid: 1), Extracted Tdc for the device*  
 :  
*Last device number, 0 or 1, Extracted Tdc for the device*
- Averaged `Tdc_idlin`  
*Calculated average Tdc*

The following is an example of ANAHCI data file.

**Example of ANAHCI data file:**

The following is an example of ANAHCI data file for the following case:

- *Number of devices* is 4
- *Vdstr* is 5 V
- *Vgstr* is 1.95 V
- *Gate width* is 1  $\mu\text{m}$
- *Gate length* is 10  $\mu\text{m}$
- All parameters are selected

Example:

```
4
5, 1.95, 1.E-6, 1.E-5
Idlin
Device Validity Tdc_idlin
1, 0, 835.5786
2, 0, 3401.432
3, 0, 6269.047
4, 0, 24366.79
Averaged Tdc_idlin
8718.2119
Gmmax
Device Validity Tdc_gmmax
1, 0, 856.0696
2, 0, 1089.116
3, 0, 1963.261
4, 0, 5580.226
Averaged Tdc_gmmax
2372.16815
Vtext
Device Validity Tdc_vtext
1, 0, 205.1144
2, 0, 327.8407
3, 0, 455.0903
4, 0, 1506.441
Averaged Tdc_vtext
623.6216
Vtci
Device Validity Tdc_vtci
1, 0, 179.3154
2, 0, 345.677
3, 0, 557.895
4, 0, 2956.594
Averaged Tdc_vtci
1009.87035
```

## Sample HCI Degradation Test Program (DCDAH)

### Overview

For the program code, edit DCDAH program.

Line or Subprogram Name	Description
1640 to 1750	Sets the GPIB interface select code and address for the 4155/4156 and 4085M. 800 means the 4155/4156 will be controlled by built-in IBASIC controller. Also assigns the FORMAT OFF attribute to the I/O path name "@Form_off" without changing the file pointers. Default GPIB interface select code and address for the 4085M are set to 722.
1770 to 2700	Assigns input parameter values and file names
2730	Calls Initial_setting subprogram, which performs the initial settings.
2740	Calls Init_hp415x subprogram, which initializes 4155/4156
2750 to 2760	Enables service request from 4155/4156 to interrupt program
2790	Calls Str_define subprogram, which determines DC stress condition
2860 to 2980	Calls subprograms that connect test devices (Swm_connect), select valid test devices (Device_check), execute initial characterization for valid devices (Param_meas), then disconnect devices (Swm_clear). If device is invalid, calls subprograms (Record_parameter) that save data and invalid flag to data file.
3020 to 3100	Calls subprograms that connect devices (Swm_connect), force stress to devices (Stress), then disconnect devices (Swm_clear).
3130	Calls Calibration subprogram, which performs calibration if required (Commented)
3220 to 3240	Calls subprograms that connect devices (Swm_connect), performs an interim characterization (Param_meas), then disconnects devices (Swm_clear).
3280 to 3330	Calls subprograms (Record_parameter) that save interim characterization data to ASCII files after each interim characterization
3340 to 3360	Calls Record_data subprogram, which saves interim characterization data to DAT type files after each interim characterization (Commented)
3400 to 3760	Calls subprograms (Stress_parameter) that draw "parameter shift vs stress time" graphs for specified devices and parameters.
3800 to 4000	Judges whether shift criterion is exceeded for each parameter
4050 to 4090	Judges whether test should be terminated

Line or Subprogram Name	Description
4080	Judges whether all devices exceed shift criterion
4090	Judges whether accumulated stress time exceeds 100,000 sec
4130 to 4210	Calls subprograms ( <i>Record_parameter</i> ) that save all interim characterization data to ASCII files after entire test is completed
4220	Calls Test_end subprogram, which initializes 4155/4156 at the end of test
4230	Displays test completion message
Initial_setting (4280)	Defines the dimension of data arrays and initializes test result data variables
Init_hp415x (4650)	Initializes 4155/4156, loads PARAM.MES and DCDAHC.STR setup files into the 4155/4156, and sets the input parameter values to the these setups, then resaves setups to disk.
Str_define (5070)	Loads IBVG.MES setup file, writes new Vdstr value for this setup, determines DC stress condition (Vgstr), then saves the determined Vgstr to the stress setup file (DCDAHC.STR).
Device_check (5440)	Selects valid test devices by measuring leakage currents
Param_meas (6350)	Determines Idlin, Gmmax, Vtext and Vtci, then calculates Idlin shift, Gmmax shift, Vtext shift, and Vtci shift
Stress (6790)	Forces stress
Record_iddata (7180)	Saves Idlin shift data to ASCII file
Record_gmdata (7810)	Saves Gmmax shift data to ASCII file
Record_vtedata (8450)	Saves Vtext shift data to ASCII file
Record_vtidata (9090)	Saves Vtci shift data to ASCII file
Stress_idgraph (9730)	Draws "Idlin shift vs stress time" graph
Stress_gmgraph (10430)	Draws "Gmmax shift vs stress time" graph
Stress_vtegraph (11120)	Draws "Vtext shift vs stress time" graph

<b>Line or Subprogram Name</b>	<b>Description</b>
Stress_vtigraph (11820)	Draws "Vtci shift vs stress time" graph
Calibration (12510)	Performs calibration of the 4155/4156
Connect (12690)	Connects one SMU port to the specified pin of the 4085M
Swm_connect (12850)	Connects four SMU ports to the specified different pins of the 4085M
Swm_clear (12970)	Disconnects all SMU ports from connected pins
DEF FNSmu (13090)	Defines FNSmu used in "Connect", "Swm_connect" and "Swm_clear" subprograms
Err_check (13200)	Checks if 4155/4156 error occurred during the test
Error_rep (13490)	Checks if 4085M error occurred during the test
Record_data (13600)	Saves interim characterization data to DAT type files
Test_end (13690)	Initializes 4155/4156 at the end of test

## Sample HCI Degradation Test Data Analysis Program (ANALYSIS) Overview

For the actual program code, edit ANALYSIS.

Line or Subprogram Name	Description
1600 to 1630	Sets the GPIB interface select code and address for the 4155/4156. 800 means the 4155/4156 will be controlled by built-in IBASIC controller. Also assigns the FORMAT OFF attribute to the I/O path name "@Form_off" without changing the file pointers.
1650 to 1830	Assigns input parameter values and file names
1850 to 1890	Prompts you to specify input parameters.
1920 to 2160	Creates labels for softkeys that allow you to select which parameters to analyze
2200	Calls Init_setting subprogram, which sets the 4155/4156 display to be not updated, then transfers Idlin/Gmmax/Vtext/Vtci shift data from ASCII file to IBASIC data arrays
2260 to 2360	Calls subprograms to analyze the Idlin shift data as described in next three rows.
2280	Calls Trans_iddata subprogram, which Transfers Idlin shift data from IBASIC data arrays to the 4155/4156
2290	Calls Stress_idgraph subprogram, which draws Idlin shift vs stress time graph
2300	Calls Analysis1 program, which determines Tdc from the Idlin shift vs stress time graph
2380 to 2480	Performs same operations for Gmmax shift data as was performed for Idlin shift data
2500 to 2600	Performs same operations for Vtext shift data as was performed for Idlin shift data
2620 to 2720	Performs same operations for Vtci shift data as was performed for Idlin shift data
2780	Calls Calculate subprogram, which calculates average Tdc
2790	Calls Save_calc_data subprogram, which saves calculated average Tdc to ASCII file
2800	Calls Print_calc_data subprogram, which prints calculated average Tdc on IBASIC screen
2830	Calls Test_end subprogram, which initializes 4155/4156 at the end of program

Line or Subprogram Name	Description
2840	Displays analysis completion message
Init_setting (2880)	Sets the 4155/4156 display to be not updated. Then transfers Idlin/Gmmax/Vtext/Vtci shift data from ASCII file to IBASIC data arrays.
Trans_iddata (3940)	Transfers Idlin shift data from IBASIC data array to the 4155/4156
Trans_gmdata (4440)	Transfers Gmmax shift data from IBASIC data array to the 4155/4156
Trans_vtedata (4940)	Transfers Vtext shift data from IBASIC data array to the 4155/4156
Trans_vtidata (5430)	Transfers Vtci shift data from IBASIC data array to the 4155/4156
Stress_idgraph (5930)	Draws "Idlin shift vs stress time" graph
Stress_gmgraph (6310)	Draws "Gmmax shift vs stress time" graph
Stress_vtegraph (6690)	Draws "Vtext shift vs stress time" graph
Stress_vtigraph (7070)	Draws "Vtci shift vs stress time" graph
Analysis1 (7450)	Determines Tdc for Idlin/Gmmax by using a linear interpolation or a power law extrapolation
Analysis2 (8130)	Determines Tdc for Vtext/Vtci by using a linear interpolation or a power law extrapolation
Calculate (8800)	Calculates average of Tdc
Save_calc_data (9220)	Saves calculated average Tdc to ASCII file
Print_calc_data (9980)	Prints calculated average Tdc on IBASIC screen
Test_end (10500)	Initializes 4155/4156 at the end of test

## Customization

This section describes how to customize the sample program to suit your test device and requirements.

### Using External Computer or Built-in Controller

The DCDABC and ANALYSIS programs are created assuming that they will be run on the built-in IBASIC controller of the 4155/4156. However, you may be able to use an external computer, such as *HP 9000 S382*.

The following lines specify the GPIB select code and address of the 4155/4156:

```
1670 Hpib_sc=8      !415X GPIB Select Code
1680 Hpib_addr=0    !415X GPIB Address
```

- If you will execute the DCDABC or ANALYSIS program using the 4155/4156 built-in IBASIC controller, use the above GPIB select code and address (800).
- If you want to execute the DCDABC or ANALYSIS program on an external computer, modify above lines. For example, if the GPIB select code is 7, and the GPIB address of the 4155/4156 is 17, modify as follows:

```
1670 Hpib_sc=7      !415X GPIB Select Code
1680 Hpib_addr=17   !415X GPIB Address
```

Also, set the 4155/4156 to NOT SYSTEM CONTROLLER on the SYSTEM: MISCELLANEOUS page.

1. Press **System** key.
2. Select MISCELLANEOUS softkey.
3. Move the field pointer to the 415x is field, then select NOT CONTROLLER softkey.
4. Move the field pointer to the 415x field of the GPIB ADDRESS area, then enter 17.

## Modifying and Specifying Setup File to Load

The DCDAHC program loads six setup files to set up the 4155/4156 for the HCI degradation test.

- Ib-Vg measurement setup file (IBVG.MES)
- Gate leakage current measurement setup file (IGLEAK.MES)
- Drain leakage current measurement setup file (IDLEAK.MES)
- Source leakage current measurement setup file (ISLEAK.MES)
- DC stress setup file (DCDAHC.STR)
- Parameter (Idlin, Gmmax, Vtext and Vtci) measurement setup file (PARAM.MES)

These setup files must be on the diskette and diskette must be in the flexible disk drive of the 4155/4156, even if you run the program from the external controller.

The setup pages of each setup file are shown in “Setup Files” on page 5-44.

Before testing, you can modify a setup and re-save it to a file on the diskette. For example, if you want to change the gate voltage in the gate leakage current measurement setup file IGLEAK.MES, which is used to select valid devices, use the following procedure:

1. Press **Get** key. In the Get dialog, select FILE CATALOG, move the field pointer to IGLEAK.MES, then select the SELECT and EXECUTE softkeys.
2. Press **Meas** key in page control key group. On the MEASURE: SAMPLING SETUP page, move the field pointer to the SOURCE field of SMU1(VG).
3. For example, to change the gate voltage from 5 V to 6 V, type 6 then press **Enter**.
4. Press **Save** key. In the Save dialog, select FILE CATALOG, move the field pointer to IGLEAK.MES, then select the SELECT and EXECUTE softkeys.

The DCDAHC program file loads the above files into the 4155/4156. The file names are defined in the following lines of the program:

```

2360 !-----Definition of measurement and stress setup files-----
2370 !
2380 Ibvq_file$="IBVG.MES"      !Ib-Vg meas. to determine Vgstr
2390 Igleak_file$="IGLEAK.MES" !Ig-time meas. to check gate leak
2400 Idleak_file$="IDLEAK.MES" !Id-time meas. to check drain leak
2410 Isleak_file$="ISLEAK.MES" !Is-time meas. to check source leak
2420 !
2430 Str_file$="DCDAHC.STR"    !DC stress setup file
2440 !Str_file$="ACDAHC.STR"   !AC stress setup file
2450 !
2460 Param_file$="PARAM.MES"  !Idlin/Gmmax/Vtext/Vtci setup file
2470 !

```

If you want to use other setup files instead, change the file names. For example, to use INTRIM.MES instead of PARAM.MES, change line 2460 as follows:

```

2460 Param_file$="INTRIM.MES" !Idlin/Gmmax/Vtext/Vtci setup file

```

Be sure that the files you specified in above lines are on the diskette before running DCDAHC program.

## Changing File for Saving Measurement Results

The DCDAHC sample program creates ASCII data files as shown in the following lines. The ANALYSIS sample program gets these files to analyze test data and determine Tdc. For the contents of these files, please refer to step 8 in “Execution” on page 5-19.

```
2480 !----- File name to save ASCII data -----
2490 Idlin_data$="ID"      !Idlinshift data file name
2500 Gmmax_data$="GM"     !Gmmaxshift data file name
2510 Vtext_data$="VTE"    !Vtextshift data file name
2520 Vtci_data$="VTI"     !Vtcishift data file name

7270 Save_file$=Idlin_data&VAL$(Device)
      :
7910 Save_file$=Gmmax_data&VAL$(Device)
      :
8550 Save_file$=Vtext_data&VAL$(Device)
      :
9190 Save_file$=Vtci_data&VAL$(Device)
```

So, the following files are created, where *XX* is test device number.

IDXX, GMXX, VTEXX, VTLXX

If you want to change the file names, modify above lines as in following example:

```
2480 !----- File name to save ASCII data -----
2490 Idlin_data$="DTA"    !Idlin shift data file name
2500 Gmmax_data$="DTB"    !Gmmax shift data file name
2510 Vtext_data$="DTC"    !Vtext shift data file name
2520 Vtci_data$="DTD"     !Vtci shift data file name
```

The following files are created, where *XX* is the test device number:

DTAXX, DTBXX, DTCXX, DTDXX

Also, you need to modify corresponding lines in the ANALYSIS program:

```
1790 !----- Get file name -----
1800 Idlin_data$="DTA"    !Idlin shift data file name
1810 Gmmax_data$="DTB"    !Gmmax shift data file name
1820 Vtext_data$="DTC"    !Vtext shift data file name
1830 Vtci_data$="DTD"     !Vtci shift data file name
```

---

### NOTE

We recommend not to change lines 7270, 7910, 8550, and 9190 of DCDAHC program. If so, you need to modify many lines in ANALYSIS program because device number is used to handle measurement data files.

## Changing Input Parameters for HCI Degradation Test

Default parameter values for the test conditions are defined from line 1770 to 2350 in the DCDAHC program. Modify these values according to your test device and environment.

```

1770 !-----Input Parameters-----
1780 !
1790 No_of_devices=4           !Number of test devices
1800 Meas_points=13          !Number of times to repeat measurements
1810 REDIM Meas_str_time(1:Meas_points)
1820 REDIM Last_test(No_of_devices)
1830 !
1840 !-----Limits for leakage tests-----
1850 Igleak_max=2.E-10        !Maximum gate leakage current
1860 Idleak_max=1.E-8        !Maximum drain leakage current
1870 Isleak_max=1.E-8        !Maximum source leakage current
1880 !
1890 !-----Drain stress voltage should be determined by Id-Vd character
istics
1900 Vdstr=5                 !Drain stress voltage
1910 Vgstr=2.5              !Gate stress voltage
1920 Vdd=5                   !Drain nominal voltage
1930 Vbb=0                   !Bulk nominal voltage
1940 !
1950 !-----Device geometries-----
1960 Gate_length=1.E-6       !Gate length
1970 Gate_width=1.E-5        !Gate width
1980 !
1990 !-----Pin assignment to determine stress bias condition-----
2000 Source_str=1            !Pin assignment of source (Stress)
2010 Drain_str=2             !Pin assignment of drain (Stress)
2020 Gate_str=3              !Pin assignment of gate (Stress)
2030 Bulk_str=4              !Pin assignment of bulk (Stress)
2040 !
2050 !--Pin assignment for forcing stresses and interim measurements
2060 !Pin assignment for Device No.=1
2070 Source(1)=5
2080 Drain(1)=6
2090 Gate(1)=7
2100 Bulk(1)=8
2110 !
2120 !Pin assignment for Device No.=2
2130 Source(2)=9
2140 Drain(2)=10
2150 Gate(2)=11
2160 Bulk(2)=12
2170 !
2180 !Pin assignment for Device No.=3
2190 Source(3)=13
2200 Drain(3)=14
2210 Gate(3)=15
2220 Bulk(3)=16
2230 !
2240 !Pin assignment for Device No.=4
2250 Source(4)=17
2260 Drain(4)=18
2270 Gate(4)=19
2280 Bulk(4)=20
2290 !
2300 !Pin assignment for Device No.=X
2310 !Source(X)=XX
2320 !Drain(X)=XX
2330 !Gate(X)=XX
2340 !Bulk(X)=XX
2350 !

```

Parameter	Description	Default
No_of_devices	Number of devices to be tested	4
Meas_points	Number of times to repeat stress/measurement cycles	13 times
Igleak_max	Maximum gate leakage current	200 pA
Idleak_max	Maximum drain leakage current	10 nA
Isleak_max	Maximum source leakage current	10 nA
Vdstr	Drain stress voltage. See note below.	5 V
Vgstr	Default gate stress voltage, used if you skip determination of gate stress bias condition	2.5 V
Vdd	Nominal drain voltage	5 V
Vbb	Nominal bulk voltage	0 V
Gate_length	Gate length	1 $\mu\text{m}$
Gate_width	Gate width	10 $\mu\text{m}$
Source_str	Source pin of switching matrix to determine gate stress voltage	1
Drain_str	Drain pin of switching matrix to determine gate stress voltage	2
Gate_str	Gate pin of switching matrix to determine gate stress voltage	3
Bulk_str	Bulk pin of switching matrix to determine gate stress voltage	4
Source(*)	Pin assignment of source terminal for stress/interim characterization loop. <i>Source (Device number)</i>	5,9,13,17
Drain(*)	Pin assignment of drain terminal for stress/interim characterization loop. <i>Drain (Device number)</i>	6,10,14,18
Gate(*)	Pin assignment of gate terminal for stress/interim characterization loop. <i>Gate (Device number)</i>	7,11,15,19
Bulk(*)	Pin assignment of bulk terminal for stress/interim characterization loop. <i>Bulk (Device number)</i>	8,12,16,20

**NOTE**

Before executing the DCDAHC program, you must determine *Vdstr* (drain stress voltage) by using "IDVD.MES" setup file stored on the diskette. Then, manually edit line 1900 of the DCDAHC program to enter the determined *Vdstr* value. Refer to "Execution" on page 5-19.

## To Change Pin Assignment

The switching matrix's pin assignment of source, gate, drain and bulk pins for each test device is defined in lines 1990 to 2280. To change pin assignment, change these lines. For example, to change the pin assignment of device 1 to following, change lines 2070 to 2100 as below:

Device Terminal	Default Pin Assignment	New Pin Assignment
Source	5	31
Drain	6	32
Gate	7	33
Bulk	8	34

```

2050 !--Pin assignment for forcing stresses and interim measurements
2060 !Pin assignment for Device No.=1
2070 Source(1)=31
2080 Drain(1)=32
2090 Gate(1)=33
2100 Bulk(1)=34

```

## To Change Number of Test Devices

Number of devices to test is defined in line 1790. Default in DCDAHC program is 4 devices.

```
1790 No_of_devices=4           !Number of test devices
```

You can change the number of test devices by manually editing this line. For example, to decrease number of devices from 4 to 3, change line 1790 as follows:

```
1790 No_of_devices=3           !Number of test devices
```

For example, to increase number of devices from 4 to 5, change line 1790 as follows:

```
1790 No_of_devices=5           !Number of test devices
```

If you increase the number of devices, you need to assign switching matrix pins for the extra devices. For example, for the fifth device, use template lines 2300 to 2340:

```

2300 !Pin assignment for Device No.=5
2310 Source(5)=21
2320 Drain(5)=22
2330 Gate(5)=23
2340 Bulk(5)=24

```

---

### NOTE

If you connect many devices, SMUs may oscillate during stress forcing due to larger stray capacitances and residual inductances.

## Changing the Cumulative Stress Times

In the DCDAHC program, the cumulative stress times are set in the following lines:

```
2540 !-----Stress duration setup-----
2550 Str_time:!                               !Stress duration data
2560 DATA    10,    20,    50
2570 DATA   100,   200,   500
2580 DATA  1000,  2000,  5000
2590 DATA 10000, 20000, 50000
2600 DATA 100000
2610 RESTORE Str_time
2620 READ Meas_str_time(*)
```

To make interim characterizations more or less frequently, modify above DATA lines.

## To Make Interim Characterizations More Frequently

Following is an example of more frequent interim characterization.

```
2540 !-----Stress duration setup-----
2550 Str_time:!                               !Stress duration data
2560 DATA    10,    20,    40,    70
2570 DATA   100,   200,   400,   700
2580 DATA  1000,  2000,  4000,  7000
2590 DATA 10000, 20000, 40000, 70000
2600 DATA 100000
2610 RESTORE Str_time
2620 READ Meas_str_time(*)
```

Also, change number of interim characterization points (Meas\_points) from 13 to 17.

```
1800 Meas_points=17           !Number of times to repeat measurements
```

## To Make Interim Characterizations Less Frequently

Following is an example of less frequent interim characterization.

```
2540 !-----Stress duration setup-----
2550 Str_time:!                               !Stress duration data
2560 DATA    10,    30
2570 DATA   100,   300
2580 DATA  1000,  3000
2590 DATA 10000, 30000
2600 DATA 100000
2610 RESTORE Str_time
2620 READ Meas_str_time(*)
```

Also, change number of interim characterization points (Meas\_points) from 13 to 9.

```
1800 Meas_points=9           !Number of times to repeat measurements
```

## Skipping Determination of Gate Stress Bias Condition

In DCDAHC program, gate stress bias condition is determined by the following line:

```
2780 !-----Determine Stress Bias Condition-----
2790 CALL Str_define           !Determine DC stress condition
2800 DISP "Connect HCI degradation test devices"
2810 PAUSE
```

To skip determination of gate stress bias condition and use the default gate stress voltage defined on line 1910, comment out lines 2790 to 2810 as follows.

```
2780 !-----Determine Stress Bias Condition-----
2790 !CALL Str_define         !Determine DC stress condition
2800 !DISP "Connect HCI degradation test devices"
2810 !PAUSE
```

## Reducing the Interval between Stress and Interim Measurement

According to JEDEC proceeding, the parameter measurements should be made as soon as possible after each stress cycle has terminated. In the DCDAHC program, line 2680 specifies to re-save test data to the ASCII file after *each* interim measurement so that data is not lost if an unexpected accident occurs:

```
2680 Save_at_last=0 !0:Save ASCII data files after each interim test
2690      !1:Save all ASCII data files after completing whole test
```

To shorten the interval, you can save test data in the ASCII file only after the termination criteria is exceeded by changing line 2680 as follows:

```
2680 Save_at_last=1 !0:Save ASCII data files after each interim test
2690      !1:Save all ASCII data files after completing whole test
```

## Selecting Parameter Shift Graphs to Draw

The DCDAHC program draws graphs of each parameter shift for each device after each interim characterization. The following lines set the flags to select device number and parameter type that you want to a graph.

```
2640 !-----Setup for drawing/saving data in main menu-----
2650 Show_device=0 !0:Draw graphs of all devices, Specify device No.
2660 Show_param=0 !0:Draw graphs of all params
2670 !1:Idlin, 2:Gmmax, 3:Vtext, 4:Vtci, -1:No graphs
```

The above sets that all parameter shift graphs will be drawn for all devices.

## To Skip Drawing Graphs

To shorten the interval, you can skip drawing parameter shift graphs. Change line 2660.

```
2640 !-----Setup for drawing/saving data in main menu-----
2650 Show_device=0 !0:Draw graphs of all devices, Specify device No.
2660 Show_param=-1 !0:Draw graphs of all params
2670 !1:Idlin, 2:Gmmax, 3:Vtext, 4:Vtci, -1:No graphs
```

The above sets that no parameter shift graphs will be drawn.

## To Draw Graphs of Specified Device Only

To draw parameter shift graphs for specified device only, change line 2650.

```
2640 !-----Setup for drawing/saving data in main menu-----
2650 Show_device=3 !0:Draw graphs of all devices, Specify device No.
2660 Show_param=0 !0:Draw graphs of all params
2670 !1:Idlin, 2:Gmmax, 3:Vtext, 4:Vtci, -1:No graphs
```

The above sets that all parameter shift graphs will be drawn, but only for device number 3.

## To Draw Graphs of Specified Parameter Only

To draw specified parameter shift graph for specified device only, change lines 2650 and 2660.

```
2640 !-----Setup for drawing/saving data in main menu-----
2650 Show_device=2 !0:Draw graphs of all devices, Specify device No.
2660 Show_param=4 !0:Draw graphs of all params
2670 !1:Idlin, 2:Gmmax, 3:Vtext, 4:Vtci, -1:No graphs
```

The above sets that the only graph drawn will be Vtci shift graph for device number 2.

## If You Don't Use Switching Matrix

If you directly connect SMUs of the 4155/4156 to the test device and don't use a switching matrix, modify the DCDAHC program as follows:

Change the number of devices to 1.

```
1790 No_of_devices=1      !Number of test devices
```

And comment out the following lines:

```
2870 ! CALL Swm_connect  !Connect test device
2970 ! CALL Swm_clear    !Disconnect test device
3040 ! CALL Swm_connect  !Connect test devices in parallel
3100 ! CALL Swm_clear    !Disconnect all test devices
3220 ! CALL Swm_connect  !Connect test device
3240 ! CALL Swm_clear    !Disconnect test device
5180 ! Connect(FNSmu(1),Gate_str)
5190 ! Connect(FNSmu(2),Source_str)
5200 ! Connect(FNSmu(3),Drain_str)
5210 ! Connect(FNSmu(4),Bulk_str)
5370 ! CALL Swm_clear
```

## Using Another Switching Matrix

The DCDAHC program assumes that you use the 4085M switching matrix. If you want to use another switching matrix, modify the following subprograms by replacing with corresponding GPIB control commands for your switching matrix.

Subprogram	Input Parameter	Functionality
Connect	Port (Port number), Pin (Pin number), Swm (GPIB select code and address of switching matrix)	Connects the specified port to the specified measurement pin
Swm_connect	Device (Device number), Source (*) (Pin assignment of source), Gate (*) (Pin assignment of gate), Drain (*) (Pin assignment of drain), Bulk (*) (Pin assignment of bulk)	Connects four terminals of specified device to SMU 1,2,3,4
Swm_clear	Swm (GPIB select code and address of switching matrix)	Disconnects all measurement ports from the measurement pins

### NOTE

For switching of the switching matrix relays, you must use **Dry Switching** method, which means switching occurs only after the object signal has been turned off or removed from the relay's terminal.

Do *not* use the wet switching method because it reduces the life of switching matrix relays. In the DCDAHC program, dry switching is executed by lines 12760, 12900, 13020 and 13250.

```
12760 OUTPUT @Hp415x; ":PAGE:SCON:STOP"
12900 OUTPUT @Hp415x; ":PAGE:SCON:STOP"
13020 OUTPUT @Hp415x; ":PAGE:SCON:STOP"
13250 OUTPUT @Hp415x; ":PAGE:SCON:STOP"
```

## Performing HCI Degradation Test with AC Stress

If desired, you can also perform HCI degradation test with AC stress. Figure 5-13 shows the setup for AC HCI degradation test. Figure 5-14 shows the measurement circuit.

**Figure 5-13** AC HCI Degradation Test Equipment Connections

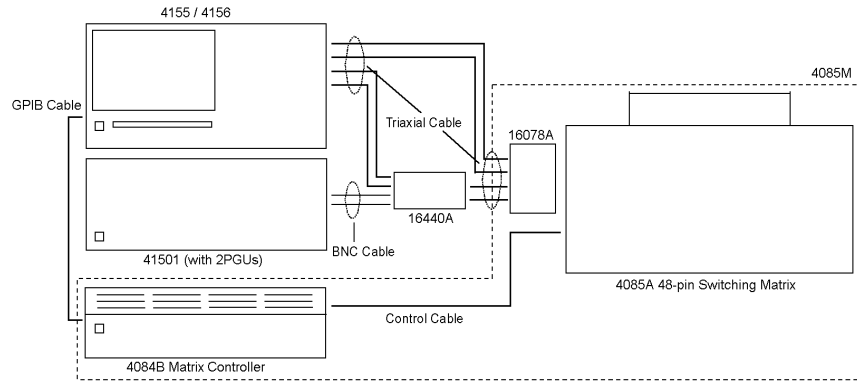

**Figure 5-14** AC HCI Degradation Test Device Connections

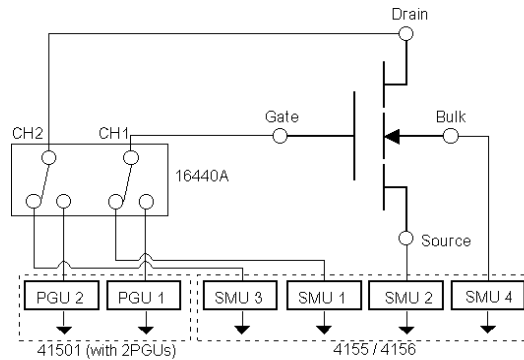

**ACDAHC.STR** file must be used instead of **DCDAHC.STR**. This file sets up the 4155/4156 as shown in “Setup Files” on page 5-44. Before testing, you must modify these settings according to your requirements, then re-save to the diskette.

In the **DCDAHC** sample program, stress setup file to be used is defined as follows:

```
2430 Str_file$="DCDAHC.STR"      !DC stress setup file
2440 !Str_file$="ACDAHC.STR"    !AC stress setup file
```

To use **ACDAHC.STR**, exchange the comment mark (!) as follows:

```
2430 !Str_file$="DCDAHC.STR"    !DC stress setup file
2440 Str_file$="ACDAHC.STR"  !AC stress setup file
```

The following lines set DC stress voltages of SMUs.

```
4990 OUTPUT @Hp415x;":PAGE:STR:SET:CONS:SMU3 ";Vdstr
5000 OUTPUT @Hp415x;":PAGE:STR:SET:CONS:SMU1 ";Vgstr
:
:
5390 OUTPUT @Hp415x;":PAGE:STR:SET:CONS:SMU1 ";Vgstr
```

Change these lines as follows so that these lines set AC stress voltages of PGU1 and PGU2.

```
4990 OUTPUT @Hp415x;":PAGE:STR:SET:PULS:PGU2:PEAK ";Vdstr
5000 OUTPUT @Hp415x;":PAGE:STR:SET:PULS:PGU1:PEAK ";Vgstr
5390 OUTPUT @Hp415x;":PAGE:STR:SET:PULS:PGU1:PEAK ";Vgstr
```

**NOTE**

Before starting AC stress test, you need to modify setup of ACDAHC .STR file. Set appropriate pulse period, width, leading time, and trailing time on STRESS: STRESS SETUP page.

### Performing Reverse Mode Test

The DCDAHC program performs forward mode tests. In this mode, the polarity between drain and source during parameter measurement is the same as during stress. For reverse mode test, it is opposite.

If you want to perform reverse mode tests, switch assignments of SMUs for drain and source in PARAM.MES file for CHANNELS: CHANNEL DEFINITION page as in the following figure, then resave it before executing test.

**Figure 5-15 Changing SMU Assignment in PARAM.MES for Reverse Mode Test**

CHANNELS: CHANNEL DEFINITION 95FEB18 01:33PM  
Idlin/Gmmax/Vtext/Vtci Measurement

\*MEASUREMENT MODE  
SWEEP

UNIT	VNAME	INAME	MODE	FCTN	STBY	SERIES RESISTANCE
SMU1: MP	V6	IG	V	VARI		0 ohm
SMU2: MP	VD	ID	V	CONST		
SMU3: MP	VS	IS	V	CONST		
SMU4: MP	VB	IB	V	CONST		
SMU5: HP						0 ohm
VSV1		-----				
VSV2		-----				
VMU1		-----		----	----	
VMU2		-----		----	----	
PGU1		-----				
PGU2		-----				
GNDV		-----			----	

SERIES RESISTANCE: 0 ohm

SWEPT

Select Measurement Mode with softkey or rotary knob. B I

CHANNEL DEF	USER FCTN	USER VAR					
-------------	-----------	----------	--	--	--	--	--

SWEEP SAMPLING DEFAULT MEASURE SETUP MEM1 M B-Tr VCE-IC MEM2 M FET VDS-ID MEM3 M FET VGS-ID MEM4 M DIODE VF-IF

NEXT PAGE

## Changing Input Parameters for Test Data Analysis

In the ANALYSIS program, the input parameters are defined on the following lines:

```

1650 !-----InputParameters-----
1660 No_of_devices=4      !Number of devices to be evaluated
1670 !
1680 !----Flag to PAUSE program after each Tdc analysis-----
1690 !If the following flag is 1, this program is paused
1700 !after drawing Shift parameter v.s. Stress time graph.
1710 !During pause, you can manually save analyzed data to
1720 !a DAT file. Then press continue. If you don't want to
1730 !PAUSE program, change following flag to 0.
1740 Pause_to_save=1
1750 !
1760 !-----Save ASCII file name-----
1770 Save_file$="ANAHCI"
1780 !

```

You can modify these values before executing ANALYSIS program.

Parameter	Description	Default
No_of_devices	Default number of devices for which to analyze data. This value is used if you do not enter a value when prompted at beginning of ANALYSIS program.	4
Pause_to_save	Flag to pause program after each Tdc extraction	1 (pause)
Save_file\$	ASCII file name in which to save calculated average Tdc	ANAHCI

## Not to Pause Program after each Tdc Extraction

The ANALYSIS program extracts Tdc for all devices and all parameters specified. The program pauses after drawing each "shift parameter vs stress time" graph so that you can manually save analyzed data to a DAT file. If you don't want to pause program, change line 1740 as follows:

```
1740 Pause_to_save=0
```

## Changing File Name to save Calculated Average Tdc

After analysis, averaged Tdc for each parameter is calculated and saved into an ASCII file. Refer to "Data Analysis" of "HCI Degradation Test Data Analysis" on page 5-8. The file name is defined in line 1770. For example, if you want to change the file name to TDCAVG, change as follows:

```

1760 !-----Save ASCII file name-----
1770 Save_file$="TDCAVG"

```

## Setup Files

This section describes the settings of the 4155/4156 setup pages that are stored in the setup files. If you change the setup page settings, you need to re-save the settings to the corresponding setup file. The DCDAHC program loads these files (except IDVD.MES) to perform the HCI degradation test.

### Setup File for Id-Vd Measurement to Determine Drain Stress Voltage

Settings of following setup pages are stored in IDVD.MES file, which is used to set up the 4155/4156 to determine Vdstr.

**NOTE**

You need to use this setup to determine Vdstr manually before running the DCDAHC program. See “Execution” on page 5-19 for details.

Figure 5-16

CHANNEL DEFINITION Page of IDVD.MES

CHANNELS: CHANNEL DEFINITION 94SEP29 01:42PM  
Id-Vd Measurement

^ MEASUREMENT MODE  
SWEEP

^ CHANNELS

UNIT	VNAME	MEASURE			STBY	SERIES RESISTANCE
		I NAME	MODE	FCTN		
SMU1: MP	VG	IG	V	VAR2		0 ohm
SMU2: MP	VS	IS	V	CONST		0 ohm
SMU3: MP	VD	ID	V	VAR1		
SMU4: MP	VB	IB	V	CONST		
VSU1		-----				
VSU2		-----				
VMU1		-----		-----	----	
VMU2		-----		-----	----	

SERIES RESISTANCE  
0 ohm  
0 ohm

SWEEP  
Select Measurement Mode with softkey or rotary knob.

CHANNEL DEF	USER FCTN	USER VAR					NEXT PAGE
-------------	-----------	----------	--	--	--	--	-----------

SWEEP  
SAMPLING  
DEFAULT MEASURE SETUP  
MEM1 M B-Tr VCE-IC  
MEM2 M FET VDS-ID  
MEM3 M FET VGS-ID  
MEM4 M DIODE VF-IF

Figure 5-17 SWEEP SETUP Page of IDVD.MES

MEASURE: SWEEP SETUP 95FEB17 09:41PM

Id-Vd Measurement

*VARIABLE	VAR1	VAR2
UNIT	SMU3: MP	SMU1: MP
NAME	VD	VG
SWEEP MODE	SINGLE	SINGLE
LIN/LDG	LINEAR	LINEAR
START	0.0000 V	3.000 V
STOP	10.000 V	4.000 V
STEP	100.0mV	500.0mV
NO OF STEP	101	3
COMPLIANCE	50.00mA	1.0000mA
POWER COMP	OFF	OFF

\*TIMING

HOLD TIME	0.0000 s
DELAY TIME	0.0000 s

\*SWEEP  Status

\*CONSTANT

UNIT	SMU2: MP	SMU4: MP		
NAME	VS	VB		
MODE	V	V		
SOURCE	0.0000 V	0.0000 V	-----	-----
COMPLIANCE	50.00mA	1.0000mA	-----	-----

10  
Enter VAR1 Stop (-100 to 100).

B I

SWEEP SETUP		MEASURE SETUP	OUTPUT SEQ			PREV PAGE	NEXT PAGE
-------------	--	---------------	------------	--	--	-----------	-----------

Figure 5-18 DISPLAY SETUP Page of IDVD.MES

DISPLAY: DISPLAY SETUP 94SEP29 01:44PM

Id-Vd Measurement

\* DISPLAY MODE

\* GRAPHICS

	Xaxis	Y1axis	Y2axis
NAME	VD	ID	
SCALE	LINEAR	LINEAR	
MIN	0.000000000 V	0.000000000 A	
MAX	10.000000 V	10.00000000uA	

\* GRID  \* LINE PARAMETER

\* DATA VARIABLES

GRAPHICS  
Select Display Mode with softkey or rotary knob.

DISPLAY SETUP	ANLYSIS SETUP					PREV PAGE	NEXT PAGE
---------------	---------------	--	--	--	--	-----------	-----------

## Setup File for Ib-Vg Measurement to Determine Gate Stress Voltage

Settings of the following setup pages are stored in the IBVG.MES file, which is used to set up the 4155/4156 to determine Vgstr during DCDAHC program.

Figure 5-19 CHANNEL DEFINITION Page of IBVG.MES

CHANNELS: CHANNEL DEFINITION 94SEP29 01:37PM

Ib-Vg Measurement

^ MEASUREMENT MODE  
SWEEP

^ CHANNELS

UNIT	VNAME	MEASURE			STBY	SERIES RESISTANCE
		I NAME	MODE	FCTN		
SMU1: MP	VG	IG	V	VAR1		0 ohm
SMU2: MP	VS	IS	V	CONST		0 ohm
SMU3: MP	VD	ID	V	CONST		
SMU4: MP	VB	IB	V	CONST		
V SU1		-----				
V SU2		-----				
V MU1		-----		-----	----	
V MU2		-----		-----	----	

SERIES RESISTANCE

0 ohm

0 ohm

MEM1 M  
B-Tr  
VCE-IC

MEM2 M  
FET  
VDS-ID

MEM3 M  
FET  
VGS-ID

MEM4 M  
DIODE  
VF-IF

SWEEP

Select Measurement Mode with softkey or rotary knob.

CHANNEL DEF	USER FCTN	USER VAR					NEXT PAGE
----------------	--------------	-------------	--	--	--	--	--------------

Figure 5-20 USER FUNCTION DEFINITION Page of IBVG.MES

CHANNELS: USER FUNCTION DEFINITION 94SEP29 01:39PM  
I b- Vg Measurement

*USER FUNCTION		
NAME	UNIT	DEFINITION
VGSTR	V	@MX
I SUB	A	- I B

VGSTR  
Enter User Function Name. (max 6 chars.)

CHANNEL DEF	USER FCTN	USER VAR				PREV PAGE	NEXT PAGE
-------------	-----------	----------	--	--	--	-----------	-----------

DELETE ROW

Figure 5-21 SWEEP SETUP Page of IBVG.MES

MEASURE: SWEEP SETUP 94SEP29 01:39PM  
I b- Vg Measurement

*VARIABLE	VAR1	VAR2
UNIT	SMU1: MP	
NAME	VG	
SWEEP MODE	SINGLE	
LIN/LOG	LINEAR	
START	0.0000 V	
STOP	5.000 V	
STEP	50.0mV	
NO OF STEP	101	
COMPLIANCE	50.00mA	
POWER COMP	OFF	

\*TIMING

HOLD TIME	0.0000 s	
DELAY TIME	0.0000 s	

\*SWEEP STOP AT ANY ABNORM Status

\*CONSTANT

UNIT	SMU2: MP	SMU3: MP	SMU4: MP	
NAME	VS	VD	VB	
MODE	V	V	V	
SOURCE	0.0000 V	6.000 V	0.0000 V	-----
COMPLIANCE	100.00mA	50.00mA	100.00mA	-----

SINGLE  
Select Sweep Mode with softkey or rotary knob.

SWEEP SETUP		MEASURE SETUP	OUTPUT SEQ			PREV PAGE	NEXT PAGE
-------------	--	---------------	------------	--	--	-----------	-----------

SINGLE  
DOUBLE

Figure 5-22 DISPLAY SETUP Page of IBVG.MES

DISPLAY: DISPLAY SETUP 94SEP29 01:40PM

lb-Vg Measurement

\* DISPLAY MODE

\* GRAPHICS

	Xaxis	Y1axis	Y2axis
NAME	VG	ISUB	
SCALE	LINEAR	LINEAR	
MIN	0.000000000 V	0.000000000 A	
MAX	5.000000 V	10.00000000nA	

\* GRID       \* LINE PARAMETER

\* DATA VARIABLES

GRAPHICS  
 Select Display Mode with softkey or rotary knob.

DISPLAY SETUP	ANLYSIS SETUP					PREV PAGE	NEXT PAGE
---------------	---------------	--	--	--	--	-----------	-----------

Figure 5-23 ANALYSIS SETUP Page of IBVG.MES

DISPLAY: ANALYSIS SETUP 94SEP29 01:40PM

lb-Vg Measurement

\* LINE1: [ ]

\* LINE2: [ ]

\* MARKER: At a point where  
 [ ISUB ] = [ MAX(ISUB) ]  
 [ ]

\* Interpolate: [OFF]

Select Line Mode with softkey or rotary knob.

DISPLAY SETUP	ANLYSIS SETUP					PREV PAGE	NEXT PAGE
---------------	---------------	--	--	--	--	-----------	-----------

### Setup File for Gate Leakage Current Measurement

Settings of following setup pages are stored in IGLEAK.MES file, which is used to set up the 4155/4156 for gate leakage current measurement during DCDAHC program.

**NOTE** This section does not show the setup pages for the IDLEAK.MES (drain leakage current) and ISLEAK.MES (source leakage current) setup files. These setup files are similar to the IGLEAK.MES setup file.

**Figure 5-24 CHANNEL DEFINITION Page of IGLEAK.MES**

CHANNELS: CHANNEL DEFINITION 94SEP29 01:47PM

Gate Leakage Current Measurement

^ MEASUREMENT MODE

^ CHANNELS

UNIT	VNAME	MEASURE			STBY	SERIES	
		I NAME	MODE	FCTN		RESISTANCE	
SMU1: MP	VG	IG	V	CONST		0 ohm	
SMU2: MP	VS	IS	V	CONST		0 ohm	
SMU3: MP	VD	ID	V	CONST			
SMU4: MP	VB	IB	V	CONST			
V SU1		-----					
V SU2		-----					
V MU1		-----			-----	-----	
V MU2		-----			-----	-----	

SAMPLING  
 Select Measurement Mode with softkey or rotary knob.

CHANNEL DEF	USER FCTN	USER VAR					NEXT PAGE
-------------	-----------	----------	--	--	--	--	-----------

**Figure 5-25 USER FUNCTION DEFINITION Page of IGLEAK.MES**

CHANNELS: USER FUNCTION DEFINITION 94SEP29 01:47PM  
Gate Leakage Current Measurement

*USER FUNCTION		
NAME	UNIT	DEFINITION
Igleak	A	@MY

Igleak  
Enter User Function Name. (max 6 chars.)

CHANNEL DEF	USER FCTN	USER VAR				PREV PAGE	NEXT PAGE
-------------	-----------	----------	--	--	--	-----------	-----------

DELETE ROW

**Figure 5-26 SAMPLING SETUP Page of IGLEAK.MES**

MEASURE: SAMPLING SETUP 95FEB17 09:30PM  
Gate Leakage Current Measurement

*SAMPLING PARAMETER		*STOP CONDITION	
MODE	LINEAR	ENABLE/DISABLE	DISABLE
INITIAL INTERVAL	100.00ms	ENABLE DELAY	0.0000000 s
NO. OF SAMPLES	10	NAME	
TOTAL SAMP. TIME	AUTO	THRESHOLD	0.00000000
		EVENT	Val > Th
HOLD TIME	1.0000 s	EVENT ND.	1
FILTER	DN		

*CONSTANT				
UNIT	SMU1: MP	SMU2: MP	SMU3: MP	SMU4: MP
NAME	V6	V5	VD	VB
MODE	V	V	V	V
SOURCE	5.000 V	0.0000 V	0.0000 V	0.0000 V
COMPLIANCE	1.0000mA	1.0000mA	1.0000mA	1.0000mA

LINEAR  
Select Sampling Mode with softkey or rotary knob. B I

SAMPLING SETUP		MEASURE SETUP	OUTPUT SEQ			PREV PAGE	NEXT PAGE
----------------	--	---------------	------------	--	--	-----------	-----------

LINEAR  
LOG10  
LOG25  
LOG50  
THINNED OUT

Figure 5-27

**ANALYSIS SETUP Page of IGLEAK.MES**

DISPLAY: ANALYSIS SETUP 94SEP29 01:50PM  
 Gate Leakage Current Measurement

NORMAL

---

\*LINE1: [ ]

GRAD

---

\*LINE2: [ ]

TANGENT

---

\*MARKER: At a point where  
 [IG ] = [MAX(IG) ]  
 [ ]

REGRES-  
SION

---

\*Interpolate: [OFF]

DISABLE

Select Line Mode with softkey or rotary knob.

Figure 5-28

**DISPLAY SETUP Page of IGLEAK.MES**

DISPLAY: DISPLAY SETUP 95FEB17 09:36PM  
 Gate Leakage Current Measurement

GRAPH-  
ICS

\*DISPLAY MODE

LIST

\*GRAPHICS

	Xaxis	Y1axis	Y2axis
NAME	BTIME	IG	
SCALE	LINEAR	LINEAR	
MIN	1.00000 s	0.000000000 A	
MAX	7.30000 s	200.000pA	

\*GRID  \*LINE PARAMETER

\*DATA VARIABLES

GRAPHICS  
 Select Display Mode with softkey or rotary knob. B I

## Setup File for Initial/Interim Characterization

Settings of following setup pages are stored in PARAM.MES file, which is used to set up the 4155/4156 for Idlin/Gmmax/Vtext/Vtci measurements during DCDAHC program.

Figure 5-29

### CHANNEL DEFINITION Page of PARAM.MES

CHANNELS: CHANNEL DEFINITION 95FEB17 09:18PM  
HCI, Initial characterization for Device=1

\*MEASUREMENT MODE  
SWEEP

\*CHANNELS

UNIT	VNAME	MEASURE	INAME	MODE	FCTN	STBY	SERIES RESISTANCE
SMU1: MP	VG	IG		V	VAR1		0 ohm
SMU2: MP	VS	IS		V	CONST		
SMU3: MP	VD	ID		V	CONST		
SMU4: MP	VB	IB		V	CONST		
SMU5: HP							0 ohm
VSV1		-----					
VSV2		-----					
VMU1		-----			-----	----	
VMU2		-----			-----	----	
PGU1		-----					
PGU2		-----					
GNDU		-----				----	

SWEEP  
Select Measurement Mode with softkey or rotary knob.

CHANNEL DEF USER FCTN USER VAR

SWEEP

MEM1 M B-Tp VCE-IC

MEM2 M FET VDS-ID

MEM3 M FET VGS-ID

MEM4 M DIODE VF-IF

NEXT PAGE

Figure 5-30

### USER FUNCTION DEFINITION Page of PARAM.MES

CHANNELS: USER FUNCTION DEFINITION 95FEB17 09:20PM  
HCI, Initial characterization for Device=1

\*USER FUNCTION

NAME	UNIT	DEFINITION
Gm		DELTA{ID}/DELTA{VG}
Vtext	V	@MX-(@MY1/@MY2)-AT{VD,1}/2
Gmmax		MAX{Gm}
Vtci	V	@L2X
Idlin	A	@L1Y1

Gm  
Enter User Function Name. (max 6 chars.)

CHANNEL DEF USER FCTN USER VAR

DELETE ROW

PREV PAGE NEXT PAGE

Figure 5-31 SWEEP SETUP Page of PARAM.MES

MEASURE: SWEEP SETUP 95FEB17 09:24PM  
 HCI, Initial characterization for Device=1

*VARIABLE	VAR1	VAR2
UNIT	SMU1: MP	
NAME	V6	
SWEEP MODE	SINGLE	
LIN/LDG	LINEAR	
START	0.0000 V	
STOP	5.000 V	
STEP	20.0mV	
NO OF STEP	251	
COMPLIANCE	20.00mA	
POWER COMP	OFF	

\*TIMING

HOLD TIME	0.0000 s	
DELAY TIME	0.0000 s	*SWEEP STOP AT COMPLIANCE Status

\*CONSTANT

UNIT	SMU2: MP	SMU3: MP	SMU4: MP	
NAME	VS	VD	VB	
MODE	V	V	V	
SOURCE	0.0000 V	100.0mV	0.0000 V	-----
COMPLIANCE	100.00mA	20.00mA	100.00mA	-----

0.02  
 Enter VAR1 Step (0 to 200).

B I

SWEEP SETUP		MEASURE SETUP	OUTPUT SEQ			PREV PAGE	NEXT PAGE
-------------	--	---------------	------------	--	--	-----------	-----------

Figure 5-32 OUTPUT SEQUENCE Page of PARAM.MES

MEASURE: OUTPUT SEQUENCE 95FEB17 09:25PM  
 HCI, Initial characterization for Device=1

*OUTPUT SEQUENCE				*TRIGGER SETUP	
	UNIT	NAME	MODE	ENABLE/DISABLE	DISABLE
1	SMU2: MP	VS	V	FUNCTION	TRIG OUT
2	SMU4: MP	VB	V	STEP DELAY	0.000 s
3	SMU1: MP	V6	V	POLARITY	POSITIVE
4	SMU3: MP	VD	V		
5	VSU1				
6	VSU2				
7	SMU5: HP				
8	PGU1				
9	PGU2				

SMU1: MP  
 SMU2: MP  
 SMU3: MP  
 SMU4: MP  
 SMU5: HP  
 VSU1  
 MORE  
 1/2

SMU2: MP  
 Select Output Sequence with softkey or rotary knob.

I

SWEEP SETUP		MEASURE SETUP	OUTPUT SEQ			PREV PAGE	NEXT PAGE
-------------	--	---------------	------------	--	--	-----------	-----------

Figure 5-33 DISPLAY SETUP Page of PARAM.MES

```

DISPLAY: DISPLAY SETUP                      95FEB17 09:27PM
HCI, Initial characterization for Device=1

*DISPLAY MODE
GRAPHICS

*GRAPHICS

```

	Xaxis	Y1axis	Y2axis
NAME	Vg	ID	Gm
SCALE	LINEAR	LINEAR	LINEAR
MIN	0.000000000 V	0.000000000 A	0.000000000
MAX	5.000000 V	2.000000000mA	1.5000000000m

```

*GRID                                *LINE PARAMETER
ON                                    OFF

*DATA VARIABLES
Vtext
Idlin

GRAPHICS
Select Display Mode with softkey or rotary knob.

```

DISPLAY SETUP	ANLYSIS SETUP					PREV PAGE	NEXT PAGE
---------------	---------------	--	--	--	--	-----------	-----------

Figure 5-34 ANALYSIS SETUP Page of PARAM.MES

```

DISPLAY: ANALYSIS SETUP                      95FEB17 09:46PM
Idlin/Gmmax/Vtext/Vtci Measurement

*LINE1: GRAD line on [Y1] at a point [WHERE]
[Vg ] = [5 ]
[ ]
Gradient: [0 ]

*LINE2: NORMAL line on [Y1] between a point [WHERE]
[ID ] = [10u ]
[ ]
and a point [WHERE]
[ID ] = [10u ]
[ ]

*MARKER: At a point where
[Gm ] = [MAX(Gm) ]
[ ]

*Interpolate: ON

GRAD
Select Line Mode with softkey or rotary knob.

```

DISPLAY SETUP	ANLYSIS SETUP					PREV PAGE	NEXT PAGE
---------------	---------------	--	--	--	--	-----------	-----------

### Setup File for DC Stress

Settings of following setup pages are stored in DCDAH.CSTR file, which is used to set up the 4155/4156 for DC stress during the DCDAH.C program.

Figure 5-35

**CHANNEL DEFINITION Page of DCDAH.CSTR**

STRESS: CHANNEL DEFINITION 94SEP29 01:34PM  
HCI DC Stress Setup File

V

I

CHANNEL ASSIGN

COMMON

DELETE ROW

^ CHANNELS

MEASURE		STRESS		
UNIT	NAME	MODE	NAME	FCTN
SMU1: MP	VG	V	Vgstr	SYNC
SMU2: MP	VS	V	Vs	SYNC
SMU3: MP	VD	V	Vdstr	SYNC
SMU4: MP	VB	V	Vsub	SYNC
VSU1				
VSU2				

^ TRIGGER SETUP

DISABLE
POLARITY POSITIVE

V

Select Mode with softkey or rotary knob.

CHANNEL DEF STRESS SETUP STRESS FORCE NEXT PAGE

Figure 5-36

**STRESS SETUP Page of DCDAH.CSTR**

STRESS: STRESS SETUP 94OCT04 08:56PM  
HCI DC Stress Setup File

FREE RUN

^ STRESS MODE

DURATION 1.0000 s

^ ACCUMULATED STRESS 0.000000 s

^ HOLD TIME 0.000000 s

^ FILTER OFF

^ STRESS CONTINUE AT ANY Status

^ CONSTANT

UNIT	SMU1: MP	SMU2: MP	SMU3: MP	SMU4: MP
NAME	Vgstr	Vs	Vdstr	Vsub
MODE	V	V	V	V
SOURCE	0.0000 V	0.0000 V	0.0000 V	0.0000 V
COMPLIANCE	100.00mA	100.00mA	100.00mA	100.00mA

^ PULSE

UNIT	NAME	PERIOD	WIDTH	DELAY TIME	PEAK VALUE	BASE VALUE	LEADING TIME	TRAILING TIME	IMPEDANCE

I

Enter Duration (0.0005 to 3.1536E+07).

CHANNEL DEF STRESS SETUP STRESS FORCE PREV PAGE NEXT PAGE

## Setup File for AC Stress

Settings of following setup pages are stored in ACDAHC.STR file, which is used to set up the 4155/4156 for AC stress. You need to customize the DCDAHC program to perform AC stress. See “Performing HCI Degradation Test with AC Stress” on page 5-41.

Figure 5-37

### CHANNEL DEFINITION Page of ACDAHC.STR

STRESS: CHANNEL DEFINITION 95FEB17 09:10PM  
HCI AC Stress Setup File

*CHANNELS					*SMU/PG SELECTOR	
UNIT	MEASURE	MODE	STRESS NAME	FCTN	MEASURE	STRESS
SMU1: MP	Vg				1 SMU	PGU
SMU2: MP	Vs	V	Vs	SYNC	2 SMU	PGU
SMU3: MP	Vd				3 DPEN	DPEN
SMU4: MP	Vb	V	Vsub	SYNC	4 DPEN	DPEN
SMU5: HP						
Vsu1						
Vsu2						
PGU1		VPULSE	Vgstr	SYNC		
PGU2		VPULSE	Vdstr	SYNC		
GNDU						

\*TRIGGER SETUP  
DISABLE  
POLARITY POSITIVE

Select Mode with softkey or rotary knob. B

CHANNEL DEF	STRESS SETUP	STRESS FORCE					NEXT PAGE
-------------	--------------	--------------	--	--	--	--	-----------

Figure 5-38

### STRESS SETUP Page of ACDAHC.STR

STRESS: STRESS SETUP 95FEB17 09:15PM  
HCI AC Stress Setup File

\*STRESS MODE  
DURATION 10.0000 s

\*ACCUMULATED STRESS  
0.000000 s

\*HOLD TIME  
0.000000 s

\*FILTER OFF

\*STRESS CONTINUE AT ANY Status

\*CONSTANT

UNIT	SMU2: MP	SMU4: MP		
NAME	Vs	Vsub		
MODE	V	V		
SOURCE	0.0000 V	0.0000 V	-----	-----
COMPLIANCE	100.00mA	100.00mA	-----	-----

\*PULSE

UNIT	PGU1	PGU2
NAME	Vgstr	Vdstr
PERIOD	20.0us	-----
WIDTH	10.0us	10.0us
DELAY TIME	0.0000 s	0.0000 s
PEAK VALUE	2.500 V	5.000 V
BASE VALUE	0.0000 V	0.0000 V
LEADING TIME	1.00us	1.00us
TRAILING TIME	1.00us	1.00us
IMPEDANCE	LOW	LOW

DURATION  
Select Stress Force Mode with softkey or rotary knob. B

CHANNEL DEF	STRESS SETUP	STRESS FORCE				PREV PAGE	NEXT PAGE
-------------	--------------	--------------	--	--	--	-----------	-----------

---

---

**6            Charge Pumping**

---

## Charge Pumping

The evolution of micro devices and ULSI technologies has created problems with device reliability. For example, hot carrier induced (HCI) degradation and short channel effects are important reliability issues for MOSFET devices. This manual discusses the evaluation of surface-states at the Si-SiO<sub>2</sub> interface of MOSFET devices which is one of these reliability issues.

Charge pumping is a measurement technique for evaluating the Si-SiO<sub>2</sub> interface-state of MOSFET devices. This technique is used to analyze the mechanics of hot carrier induced degradation.

This operation manual shows how to use the charge pumping method to evaluate the interface-state with the 4155/4156.

“Charge Pumping Methods” introduces three methods of charge pumping.

“Square Pulse Method” explains the theory of the square pulse method and how to perform the test using the sample program. An example measurement result is also shown.

“Square Pulse Method without Program” describes how to perform a square pulse method charge pumping test without using a program. An example measurement result is also shown.

“Triangular Pulse Method” explains the theory of the triangular pulse method and how to perform the test using the sample program. An example measurement result is also shown.

“Trapezoidal Pulse Method” explains the theory of the trapezoidal pulse method and how to perform the test using the sample program. An example measurement result is also shown.

“Program Modification Examples” describes examples of sample program modifications.

## Charge Pumping Methods

Charge pumping is one of the measurement methods that extracts the Si-SiO<sub>2</sub> interface-state density and the capture cross-section of the MOSFET devices. Figure 6-1 shows the measurement circuit diagram of a charge pumping test. The gate of a MOSFET device is connected to a pulse generator, A reverse bias (V<sub>r</sub>) is applied to the source and the drain, while the substrate current is measured. This current is caused by the repetitive recombination of minority carriers with majority carriers at the interface traps when the gate pulses the channel between inversion and accumulation. Three different charge pumping methods are described below:

### Square Pulse Method

The square pulse method extracts the interface-state density from the charge pumping current versus the pulse base voltage curve. The curve is obtained by applying a fixed-shape square pulse to the gate, measuring the charge pumping current (substrate current), stepping up the pulse base voltage, and repeating the measurement.

### Triangular Pulse Method

The triangle pulse method extracts the mean interface-state density and capture cross-section from the recombined charge versus the pulse frequency curve. The curve is obtained by applying a constant height triangle wave to the gate, measuring the charge pumping current, stepping up the pulse frequency, repeating the measurement, and extracting the recombined charge.

### Trapezoidal Pulse Method

The trapezoidal pulse method presents the energy distribution of interface-state (interface-state density versus energy curve). The characteristics are obtained by applying a fixed height trapezoidal pulse to the gate, measuring the charge pumping current, stepping up the pulse rise-time or pulse fall-time, repeating the measurement, and then extracting the interface-state density.

Figure 6-1

Measurement Circuit Diagram

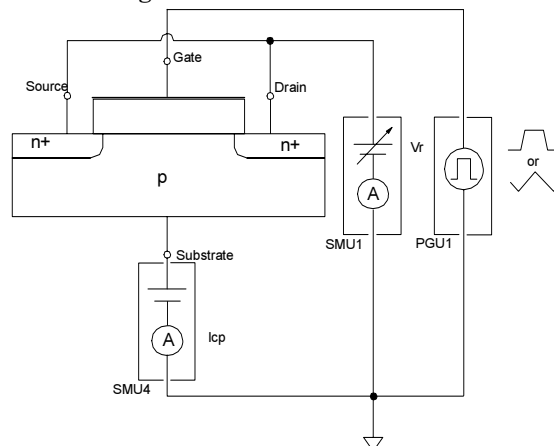

## Equipment Required

The sample programs explained here are the Instrument BASIC programs which run on the 4155/4156 built-in IBASIC controller. To execute a sample program, the following equipment is required.

- Agilent 4155 or Agilent 4156 Semiconductor Parameter Analyzer
- Agilent 41501 Expander equipped with Pulse Generator Units
- Two triaxial cables
- One coaxial cable
- Test fixture or probe station
- This operation manual
- Diskette that contains the sample program files and the 4155/4156 setup files

To perform the square pulse method test without using a program, as described in “Square Pulse Method without Program” on page 6-13, all the equipment listed above is required.

---

### NOTE

Program files and setup files are stored on the Sample Application Program Disk furnished with the 4155/4156. Before executing the program, copy the files to your working diskette. You should keep the original diskette as backup.

---

## Square Pulse Method

The square pulse method extracts interface-state density ( $\overline{Dit}$ ), as shown in Figure 6-2. This figure is a flowchart of the sample program described here. A square pulse should be applied to the gate, and the substrate leakage current should be measured at the point shown in Figure 6-3.

The amplitude of the square pulse is not changed, and the pulse base voltage (BaseV) is varied from well-below to well-above the threshold voltage. The substrate leakage current is measured for each pulse base voltage. For every sampling measurement, the maximum substrate current is defined as the charge pumping current (Icp). The pulse output, the sampling measurement, and the Icp extraction are performed using the setup information found in the 4155/4156 measurement setup file, not in the sample program.

The pulse base voltage is increased with each iteration of the measurement loop. Then the charge pumping current (Icp) versus pulse base voltage (BaseV) curve is drawn.  $\overline{Dit}$  is extracted from the Icp versus BaseV curve.

### To Extract Interface-state Density

The interface-state density ( $\overline{Dit}$ ) is extracted using the equation shown below. The sample program uses the maximum Icp value for this calculation. The maximum Icp value is obtained from the charge pumping current (Icp) versus pulse base voltage (BaseV) curve.

$$I_{cp} = f \times Q_{ss} = f \times q \times Ag \times \overline{Dit}$$

So,

$$\overline{Dit} = I_{cp} / (f \times q \times Ag)$$

where,

- $Q_{ss}$**  : Recombined charge per pulse period
- $f$**  : Pulse frequency
- $q$**  : Electron charge
- $Ag$**  : Channel area of the transistor
- $\overline{Dit}$**  : Mean interface-state density, averaged over the energy levels swept through by the Fermi level ( $\text{cm}^{-2} \text{eV}^{-1}$ )

Figure 6-2 Flowchart of Square Pulse Method

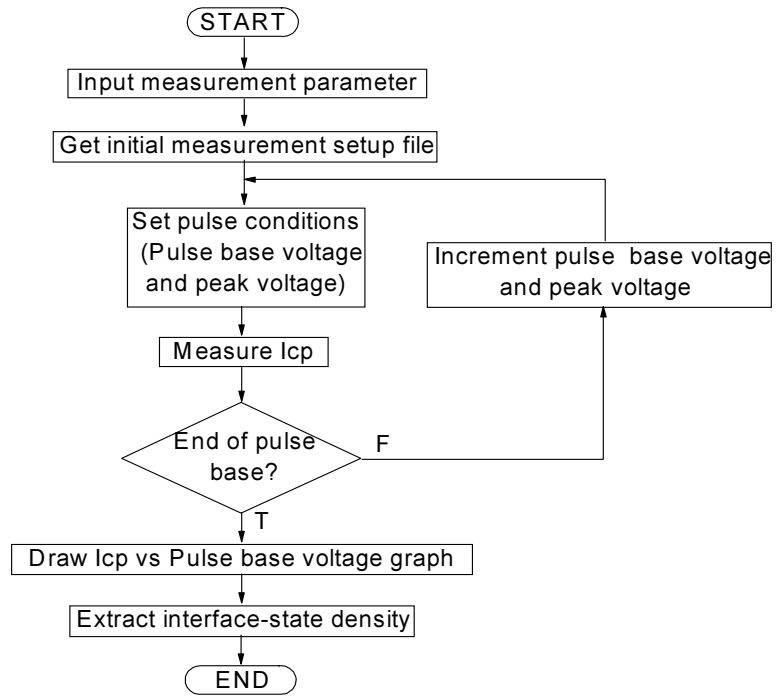
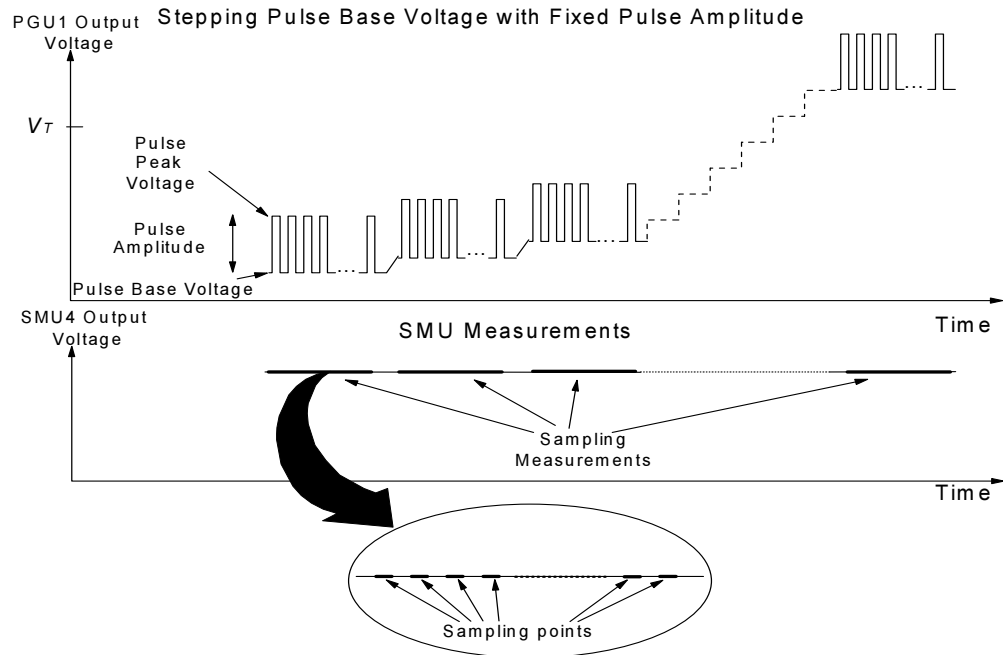

Figure 6-3 Timing Chart of Square Pulse Method



## Program Files Required

The following files are used for the square pulse method test:

<b>CPV</b>	Square pulse method sample program. IBASIC program file. ASCII format.
<b>CHP.MES</b>	Sample setup file for the square pulse method. 4155/4156 setup file.

---

**NOTE**

The sample program file and the 4155/4156 setup file should be stored on your working diskette. The diskette must be inserted in the 4155/4156 built-in flexible disk drive during the program execution. The sample program loads the setup file and automatically saves the data files on the diskette.

---

## Example Measurement Result Files

The following files save example data created after executing the CPV program. The files are stored on the Sample Application Program Disk.

<b>CHP.DAT</b>	4155/4156 setup and measurement data file.
<b>CHP.ASC</b>	ASCII format file.

## Sample Setup File

The square pulse method sample program loads and uses the information in the 4155/4156 setup file for the measurement. For the actual setup information in the setup file you use, load the file using the 4155/4156 filer function, and then refer to the 4155/4156 setup screen.

The following table shows the key setup screens of the CHP.MES sample setup file.

---

**NOTE**

If you change the setup information of the sample setup file for your application, load the sample setup file, change the setup, and save it as a new file.

To use the new file for the measurement, perform one of the following:

- Run the sample program, and select the File Name and Setup File softkeys, and enter the file name.
  - Edit the sample program, and change the initial value for the setup file name. See “To Change the Initial Value of Input Parameters” on page 6-36.
-



### PGU SETUP screen

MEASURE: P6U SETUP 98SEP21 10:57AM  
Charge Pumping Current Measurement Setup

*PULSE		
UNIT	P6U1	P6U2
NAME	V6	
PERIOD	6.0us	-----
WIDTH	1.0us	
DELAY TIME	0.0000 s	
PEAK VALUE	1.000 V	
BASE VALUE	-5.000 V	
LEADING TIME	100ns	
TRAILING TIME	100ns	
IMPEDANCE	LOW	
PULSE COUNT	FREE RUN	-----

  

*CONSTANT		
UNIT	P6U1	P6U2
NAME		
SOURCE		

6E-06  
Enter P6U Pulse Period (<2E-06 to 10).

SAMPLING SETUP | P6U SETUP | MEASURE SETUP | OUTPUT SEQ | | | PREV PAGE | NEXT PAGE

Use this screen to set the output condition used to pulse the gate. During the execution of the sample program PEAK VALUE and BASE VALUE are automatically changed by the program for each sampling measurement. For the definition of the pulse setup parameters, see the figure below.

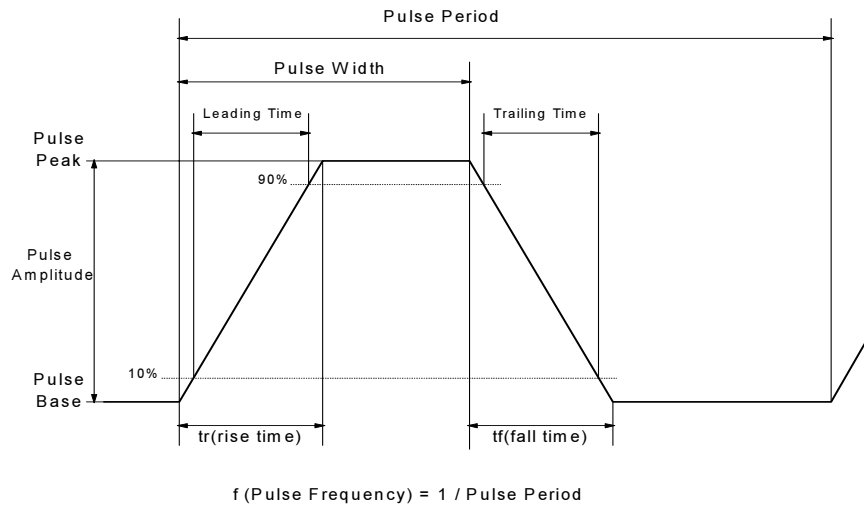

### DISPLAY SETUP screen

DISPLAY: DISPLAY SETUP 98SEP21 10:58AM  
Charge Pumping Current Measurement Setup

\*DISPLAY MODE  
GRAPHICS

\*GRAPHICS

NAME	Xaxis	V1axis	V2axis
SCALE	LINEAR	ISUB	
MIN	0.000000000 s	1.000pA	
MAX	2.00000 s	1.000000000uA	

\*GRID ON

\*LINE PARAMETER ON

\*DATA VARIABLES  
ISB

GRAPHICS  
Select Display Mode with softkey or rotary knob.

DISPLAY SETUP | ANALYSIS SETUP | | | | | PREV PAGE | NEXT PAGE

Use this screen to set the measurement and display parameters. For the sampling measurement, the x-axis must be set to @TIME. To measure the substrate current, the y-axis must be set to ISUB. ISB must be set to the DATA VARIABLES field to display the ISB value on the GRAPH/LIST: GRAPHICS screen.

## To Execute the Sample Program

This procedure describes how to execute the sample program.

1. Display the SYSTEM: MISCELLANEOUS screen, and set the REMOTE CONTROL COMMAND SET field to 4155/56.
2. Display the All IBASIC screen by pressing the front-panel **Display** key twice.
3. Insert a diskette containing the CPV program file and the setup file used for this test into the 4155/4156 built-in flexible disk drive.
4. Get the CPV sample program as follows:
  - a. Select the GET "" softkey.
  - b. Enter CPV as shown below.

```
GET"CPV"
```
  - c. Press the front-panel **Enter** key.
5. Press the front-panel **Run** key to execute the program.
6. To change the following measurement conditions, select the appropriate softkeys, and enter the new value:
  - File Name (select the File Name softkey)
    - Setup file name to get (enter the name of the setup file if it has been changed)
    - ASCII file name to save the result data (see Figure 6-5)
    - DAT file name to save the result data (see Figure 6-4)
  - Pulse Voltage (select the Pulse Voltage softkey)
    - Pulse Amplitude [V]
    - Start pulse base voltage [V]
    - Stop pulse base voltage [V]
    - Step pulse base voltage [V]
  - Pulse Time (select the Pulse Time softkey)
    - Pulse period [sec]
    - Pulse width [sec]
    - Pulse leading time [sec]
    - Pulse trailing time [sec]
  - SMU Bias (select the SMU BIAS softkey)
    - Drain and Source bias [V]
    - Substrate bias [V]
  - Device parameters (select the Device Parameter softkey)
    - Channel width [cm]
    - Channel length [cm]
7. Connect the device as shown in Figure 6-1.
8. To start the test, select the Measure softkey.

### After the Measurement

After the measurement, the CPV program automatically performs the following functions:

- Displays a list of the pulse base voltage (BaseV) and the charge pumping current (Icp) on the All IBASIC screen.
- Changes the 4155/4156 setup information. This displays the Icp versus BaseV curve, and extracts and displays the interface-state density ( $\overline{Dit}$ ). To review changes in the setup file, see the table on the next page.
- Displays the Icp versus BaseV curve on the GRAPH/LIST: GRAPHICS screen. See Figure 6-4.
- Saves the ASCII file to the diskette inserted in the 4155/4156 built-in flexible disk drive. See Figure 6-5.
- Saves the DAT file to the diskette inserted in the 4155/4156 built-in flexible disk drive.

Figure 6-4

### Square Pulse Method Measurement Result

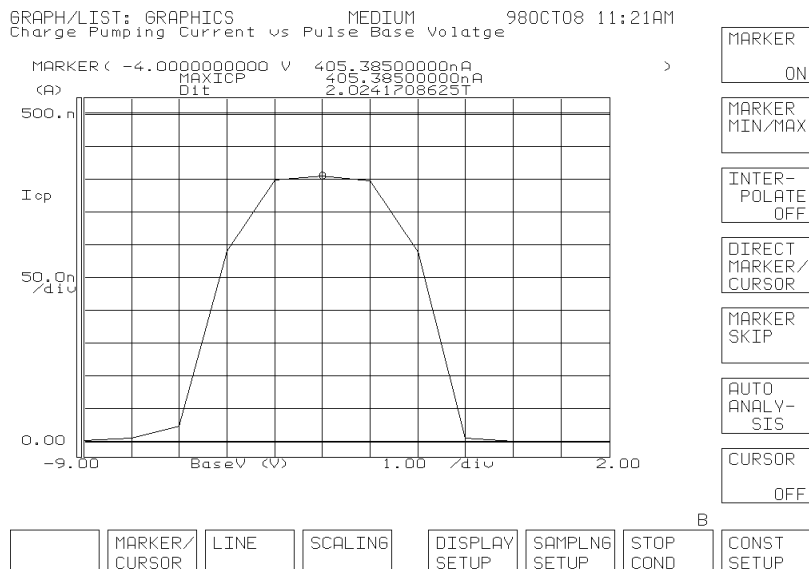

Figure 6-5

### Example Data of ASCII File

```
6,-9, 2, 1, 12
2.E-6, 1.E-6, 1.E-7, 1.E-7
-9,-8,-7,-6,-5,-4,-3,-2,-1, 0, 1, 2
8.8758E-9, 3.4555E-8, 2.1863E-7, 4.1005E-7, 4.5665E-7, 4.4278E-7, 3.5182E-7, . . . .
```

In Figure 6-5, the first line is the gate pulse amplitude [V], the gate pulse base start voltage [V], the base stop voltage [V], the base step voltage [V], and the number of steps in the gate pulse base voltage.

The Second line is the pulse period [sec], the pulse width [sec], the pulse leading time [sec], and the pulse trailing time [sec].

The third line is the pulse base voltage (BaseV value) [V].

The last line is the charge pumping current (Icp value) [A].

# Charge Pumping Square Pulse Method

<p><b>USER FUNCTION DEFINITION screen</b></p> <p>CHANNELS: USER FUNCTION DEFINITION      98SEP21 11:03AM Charge Pumping Current vs Pulse Base Volatge</p> <p>*USER FUNCTION</p> <table border="1" style="width: 100%; border-collapse: collapse;"> <thead> <tr> <th>NAME</th> <th>UNIT</th> <th>DEFINITION</th> </tr> </thead> <tbody> <tr> <td>MAXICP</td> <td>A</td> <td>MAX(Icp)</td> </tr> <tr> <td>f</td> <td>Hz</td> <td>500000</td> </tr> <tr> <td>Ag</td> <td>cm<sup>2</sup></td> <td>2.5E-6</td> </tr> <tr> <td>Dit</td> <td></td> <td>MAXICP/q/f/Ag</td> </tr> </tbody> </table> <p>MAXICP Enter User Function Name. (max 6 chars.)</p> <p>CHANNEL DEF    USER FCTN    USER VAR    <input type="text"/>    <input type="text"/>    <input type="text"/>    <input type="text"/>    PREV PAGE    NEXT PAGE</p>	NAME	UNIT	DEFINITION	MAXICP	A	MAX(Icp)	f	Hz	500000	Ag	cm <sup>2</sup>	2.5E-6	Dit		MAXICP/q/f/Ag	<p>ISAV and ISB are deleted from the original setup. MAXICP, f, Ag, and Dit are added instead. MAXICP is the maximum Icp value, f is frequency of the gate pulse, Ag is the area of gate, and Dit is the interface-state density. The equation shown in “To Extract Interface-state Density” on page 6-5 is defined in the DEFINITION field of Dit, not in the sample program.</p>					
NAME	UNIT	DEFINITION																			
MAXICP	A	MAX(Icp)																			
f	Hz	500000																			
Ag	cm <sup>2</sup>	2.5E-6																			
Dit		MAXICP/q/f/Ag																			
<p><b>USER VARIABLE DEFINITION screen</b></p> <p>CHANNELS: USER VARIABLE DEFINITION      98SEP21 11:10AM Charge Pumping Current vs Pulse Base Volatge</p> <p>*USER VARIABLE</p> <table border="1" style="width: 100%; border-collapse: collapse;"> <thead> <tr> <th>NAME</th> <th>UNIT</th> <th>SIZE</th> </tr> </thead> <tbody> <tr> <td>BaseV</td> <td>V</td> <td>12</td> </tr> <tr> <td>Icp</td> <td>A</td> <td>12</td> </tr> </tbody> </table> <p>BaseV Enter User Variable Name. (max 6 chars.)</p> <p>CHANNEL DEF    USER FCTN    USER VAR    <input type="text"/>    <input type="text"/>    <input type="text"/>    <input type="text"/>    PREV PAGE    NEXT PAGE</p>	NAME	UNIT	SIZE	BaseV	V	12	Icp	A	12	<p>User variables are newly defined. BaseV is the pulse base voltage. Icp is the charge pumping current. The number of data points for both BaseV and Icp are automatically calculated by the sample program using the start, stop, and step values of the pulse base voltage. In this example, the number of data points is 12, because the start value is -9 V, the stop value is 2 V, and step value is 1 V. The values of the variables are defined in the sample program.</p>											
NAME	UNIT	SIZE																			
BaseV	V	12																			
Icp	A	12																			
<p><b>DISPLAY SETUP screen</b></p> <p>DISPLAY: DISPLAY SETUP      980C108 11:21AM Charge Pumping Current vs Pulse Base Volatge</p> <p>*DISPLAY MODE <input checked="" type="checkbox"/> GRAPHICS</p> <p>*GRAPHICS</p> <table border="1" style="width: 100%; border-collapse: collapse;"> <thead> <tr> <th></th> <th>Xaxis</th> <th>Y1axis</th> <th>Y2axis</th> </tr> </thead> <tbody> <tr> <td>NAME</td> <td>BaseV</td> <td>Icp</td> <td></td> </tr> <tr> <td>SCALE</td> <td>LINEAR</td> <td>LINEAR</td> <td></td> </tr> <tr> <td>MIN</td> <td>-9.000000000 V</td> <td>0.000000000 A</td> <td></td> </tr> <tr> <td>MAX</td> <td>2.000000000 V</td> <td>500.0000000nA</td> <td></td> </tr> </tbody> </table> <p>*GRID      <input checked="" type="checkbox"/> ON      *LINE PARAMETER      <input checked="" type="checkbox"/> ON</p> <p>*DATA VARIABLES <input checked="" type="checkbox"/> MAXICP <input checked="" type="checkbox"/> Dit</p> <p>GRAPHICS Select Display Mode with softkey or rotary knob.</p> <p>DISPLAY SETUP    ANALYSIS SETUP    <input type="text"/>    <input type="text"/>    <input type="text"/>    <input type="text"/>    PREV PAGE    NEXT PAGE</p>		Xaxis	Y1axis	Y2axis	NAME	BaseV	Icp		SCALE	LINEAR	LINEAR		MIN	-9.000000000 V	0.000000000 A		MAX	2.000000000 V	500.0000000nA		<p>In the original setup, the x-axis was @TIME, and the y-axis was ISUB when measuring the substrate current. However, to display the Icp versus BaseV curve, BaseV and Icp are set to the x-axis and y-axis, respectively. Dit must be set to the DATA VARIABLES field to display the <u>Dit</u> value on the GRAPH/LIST: GRAPHICS screen.</p>
	Xaxis	Y1axis	Y2axis																		
NAME	BaseV	Icp																			
SCALE	LINEAR	LINEAR																			
MIN	-9.000000000 V	0.000000000 A																			
MAX	2.000000000 V	500.0000000nA																			

## Square Pulse Method without Program

The “Square Pulse Method” introduces the theory of the square pulse method and describes how to perform the test using the CPV sample program. This section describes how to perform the square pulse method test without using a program.

The measurement method described in this section uses the sweep measurement mode, not the sampling measurement mode used by the CPV sample program. The CPV sample program steps up the gate pulse base and peak voltage, while keeping the source, drain, and substrate voltages constant. This bias control can be replaced by keeping the gate pulse bias constant, and stepping down the voltage for the other terminals. The 4155/4156 forces a constant pulse to the gate, and forces the staircase sweep voltage to the source, drain, and substrate. Then the VAR1 function is used for the substrate voltage, and the VAR1' function is used for the source and drain voltage. See Figure 6-6. For the measurement setup, see “Sample Setup File” on page 6-13.

**Figure 6-6** Square Pulse Method Measurement Circuit

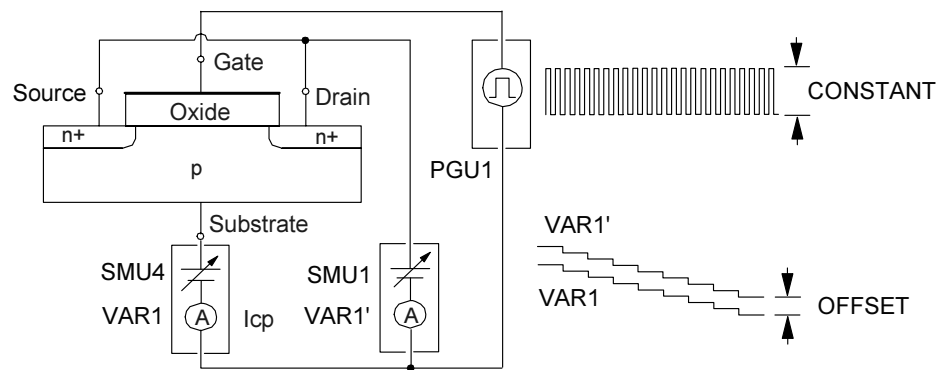

### Requirement

The following file is required for the test:

**CPV.DAT** 4155/4156 measurement setup and result data file. This file saves the measurement setup data and an example of the measurement result data.

### NOTE

You can change the measurement setup information of the CPV.DAT file to suit your device. Open and change the setup data on the 4155/4156. After the changes have been made, save the setup data file with a name other than CPV.DAT. You should keep the original file as a backup.

### Sample Setup File

The key setup screens of the CPV.DAT file are shown in the following table.

# Charge Pumping

## Square Pulse Method without Program

### CHANNEL DEFINITION screen

CHANNELS: CHANNEL DEFINITION 980CT08 11:13AM

\*MEASUREMENT MODE  
SWEEP

\*CHANNELS

UNIT	VNAME	INAME	MODE	FCTN	STBY	SERIES RESISTANCE
SMU1:MP	VdVs	IdIs	V	VAR1'		0 ohm
SMU2:MP						
SMU3:MP						
SMU4:MP	Vsb	Icp	V	VAR1		0 ohm
SMU5:HP						
VSU1						
VSU2						
VMU1						
VMU2						
P6U1	Vg		VPULSE	CONST		
P6U2						
GNDU						

SWEEP  
Select Measurement Mode with softkey or rotary knob.

CHANNEL DEF USER FCTN USER VAR

Use this screen to define the measurement units set the gate pulse, drain and source, and substrate voltages, and to measure the charge pumping current (Icp). The measurement circuit diagram shown in Figure 6-6 uses this definition.

SWEEP

SAMPLING

DEFAULT MEASURE SETUP

MEM1 M B-Tr VCE-IC

MEM2 M FET VDS-ID

MEM3 M FET VGS-ID

MEM4 M DIODE VF-IF

---

### USER FUNCTION DEFINITION screen

CHANNELS: USER FUNCTION DEFINITION 980CT08 01:16PM

\*USER FUNCTION

NAME	UNIT	DEFINITION
BaseV	V	-Vsb
MAXIcp	A	MAX(Icp)
f	Hz	1/PERIOD
Ag	cm <sup>2</sup>	2.5E-6
Dit		MAXIcp / (f*Ag*q)

BaseV  
Enter User Function Name. (max 6 chars.)

CHANNEL DEF USER FCTN USER VAR

This setup screen calculates and defines the following parameters:

**BaseV:** Pulse base voltage

**MAXIcp:** Maximum charge pumping current

**f:** Pulse frequency

**Ag:** Channel area

**Dit:** Interface-state density ( $\overline{Dit}$ )

This definition is used to display the Icp versus BaseV curve, and the MAXIcp and  $\overline{Dit}$  values.

DELETE ROW

---

### MEASUREMENT SETUP screen

MEASURE: SWEEP SETUP 980CT08 11:14AM

*VARIABLE	VAR1	VAR2	UNIT	VAR1'
UNIT	SMU4:MP		SMU1:MP	
NAME	Vsb		VdVs	
SWEEP MODE	SINGLE		OFFSET	500.0mV
LIN/LOG	LINEAR		RATIO	1.000
START	9.000 V		COMPLIANCE	100.00mA
STOP	-2.0000 V		POWER COMP	OFF
STEP	-200.0mV			
NO OF STEP	56			
COMPLIANCE	100.00mA			
POWER COMP	OFF			

\*TIMING  
HOLD TIME 100ms  
DELAY TIME 100.0ms \*SWEEP CONTINUE AT ANY Status

\*CONSTANT

UNIT	NAME	MODE	SOURCE	COMPLIANCE

SINGLE  
Select Sweep Mode with softkey or rotary knob.

SWEEP SETUP P6U SETUP MEASURE SETUP OUTPUT SEQ

Use this screen to set the staircase sweep condition of the substrate voltage (VAR1) and the source and drain voltage (VAR1'). The source and drain voltage is 0.5 V more than the substrate voltage.

SINGLE

DOUBLE

**PGU SETUP screen**

MEASURE: P6U SETUP 980CT08 11:15AM

*PULSE		
UNIT	P6U1	P6U2
NAME	Vg	
PERIOD	2.0us	-----
WIDTH	1.0us	
DELAY TIME	0.0000 s	
PEAK VALUE	6.000 V	
BASE VALUE	0.0000 V	
LEADING TIME	100ns	
TRAILING TIME	100ns	
IMPEDANCE	LOW	
PULSE COUNT	FREE RUN	-----

*CONSTANT		
UNIT	P6U1	P6U2
NAME		
SOURCE		

2E-06  
Enter P6U Pulse Period (2E-06 to 10).

Use this screen to set the pulse output condition used to force the constant voltage pulse to the gate. For the definition of the pulse setup parameters, see the figure below.

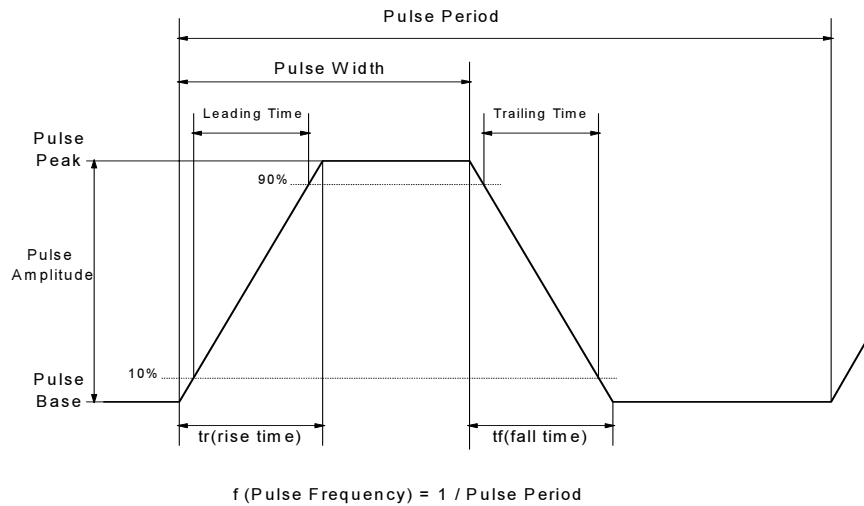

**DISPLAY SETUP screen**

DISPLAY: DISPLAY SETUP 980CT08 01:16PM

\*DISPLAY MODE  
 GRAPHICS

\*GRAPHICS

NAME	Xaxis	V1axis	V2axis
SCALE	BaseV	Icp	
MIN	-9.000000000 V	0.000000000 A	
MAX	2.000000000 V	500.000000nA	

\*GRID  \*LINE PARAMETER

\*DATA VARIABLES  
 MAXIcp  
 Dit

GRAPHICS  
Select Display Mode with softkey or rotary knob.

Use this screen to set the measurement parameters and display parameters. The GRAPH/LIST: GRAPHICS screen displays the Icp versus BaseV curve, the maximum charge pumping current (MAXIcp), and the interface-state density (Dit).

## To Execute the Measurement

This procedure describes how to execute the measurement.

1. Insert a diskette containing the CPV.DAT file or the setup file you are using into the 4155/4156 built-in flexible disk drive.
2. Get the measurement setup file as follows:
  - a. Press the front-panel **GET** key.
  - b. Enter the file name, without an extension, in the NAME field. To get the CPV.DAT file, enter CPV.
  - c. Select the MES or DAT softkey to set the file type in the TYPE field. To get the CPV.DAT file, select the DAT softkey.
  - d. Press the front-panel **Enter** key.
3. (Optional) Change the measurement setup as desired.
4. Connect the device as shown in Figure 6-6.
5. Select the front-panel **Single** key to start a single sweep measurement.

## After the Measurement

After the measurement, the charge pumping current ( $I_{cp}$ ) versus pulse base voltage (BaseV) curve is displayed on the GRAPH/LIST: GRAPHICS screen. The screen also displays the maximum  $I_{cp}$  value (MAXI $_{cp}$ ) and the interface-state density ( $\overline{D}it$ ). See Figure 6-7.

Figure 6-7

### Square Pulse Method Measurement Result

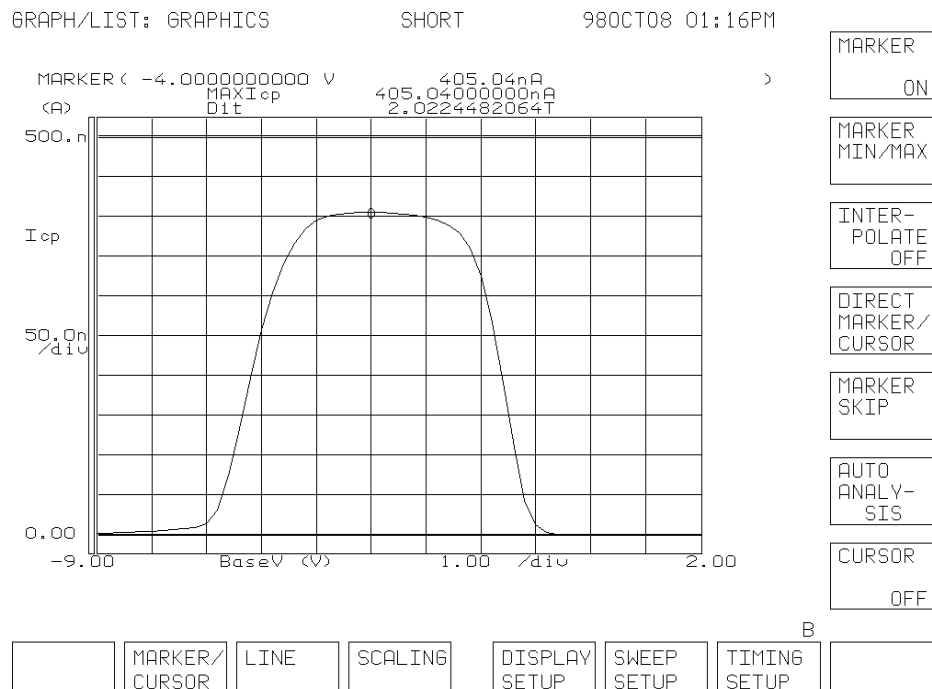

## Triangular Pulse Method

The triangle pulse method extracts the mean interface-state density ( $\overline{D_{it}}$ ) and the capture cross section ( $\sigma$ ) as shown in Figure 6-8. The triangle pulse should be applied to the gate, and the substrate leakage current measured at the point shown in Figure 6-9.

The amplitude of the triangle pulse is held constant while varying the frequency of the pulse. The substrate leakage current is measured by the sampling measurement mode for each frequency change. For every sampling measurement, the averaged substrate current is defined as the charge pumping current ( $I_{cp}$ ). The pulse output, the sampling measurement, and the  $I_{cp}$  extraction are performed using the setup information in the 4155/4156 measurement setup file, not in the sample program.

The pulse frequency is increased with each iteration of the measurement loop. Then the recombined charge ( $Q_{ss}$ ) versus pulse frequency ( $f$ ) curve is drawn. Where,  $Q_{ss}$  is calculated by the program using the following equation.  $\overline{D_{it}}$  and  $\sigma$  are extracted from the  $Q_{ss}$  versus pulse frequency curve.

$$Q_{ss} = I_{cp} / f$$

Figure 6-8

Flowchart of Triangle Pulse Method

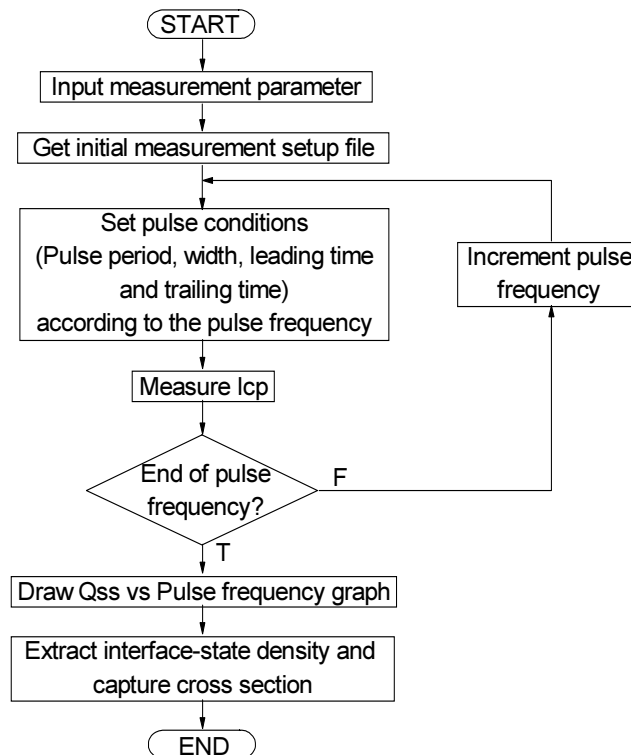
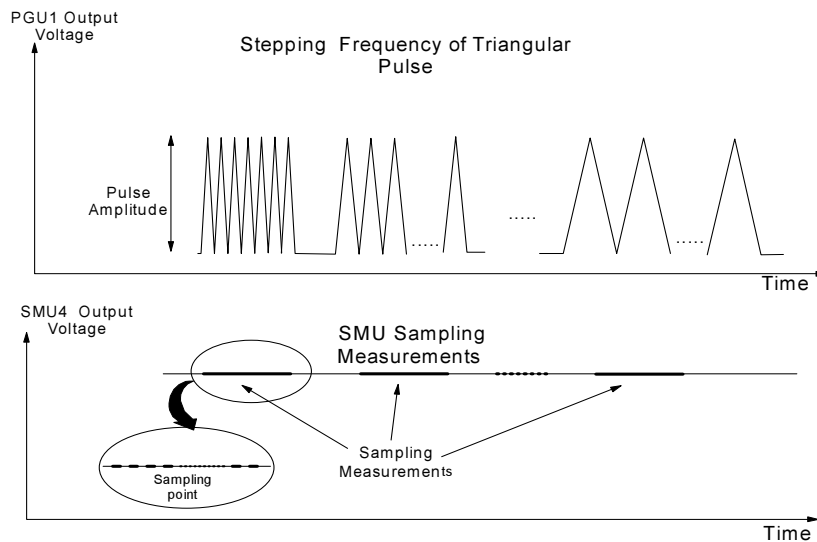

Figure 6-9 Timing Chart of Triangle Pulse Method



### To Extract Interface-state Density

The mean interface-state density ( $\overline{D_{it}}$ ) is extracted using the following equation, where, *Slope* is the slope of the regression line for the recombined charge ( $Q_{ss}$ ) versus pulse frequency ( $f$ ) curve on a linear-log graph. The slope value is obtained from the graph using the auto-analysis capability and the read-out function of the 4155/4156.

$$\frac{dQ_{ss}}{d\log f} = \frac{2qkT\overline{D_{it}}}{\log e} Ag = \text{Slope}$$

So,

$$\overline{D_{it}} = \frac{\log e \cdot \text{Slope}}{2qkTA_g}$$

where,

- Q<sub>ss</sub>** : Recombined charge per pulse period
- f** : Pulse frequency
- q** : Electron charge
- k** : Boltzmann's constant
- T** : Temperature
- A<sub>g</sub>** : Channel area of the transistor
- $\overline{D_{it}}$**  : Mean interface-state density ( $\text{cm}^{-2} \text{eV}^{-1}$ )

## To Extract Capture Cross Section

When using triangular pulses, the recombined charge ( $Q_{ss}$ ) can be calculated using the following equation.

$$Q_{ss} = 2q \cdot \overline{Dit} \cdot Ag \cdot k \cdot T \cdot \left[ \ln(v_{th} \cdot n_i \cdot \sqrt{\sigma_n \cdot \sigma_p}) + \ln\left(\frac{\sqrt{\alpha \cdot (1-\alpha)} \cdot |V_{FB} - V_T|}{f \cdot |V_{GH} - V_{GL}|}\right) \right]$$

The geometric mean of the capture cross section ( $\sigma$ ) is extracted using the following equation, where  $f_0$  is the frequency where the charge becomes zero. This means that  $f_0$  is the x-axis intercept of the regression line for the  $Q_{ss}$  versus pulse frequency curve on a linear-log graph. The x-axis intercept is obtained from the graph using the auto-analysis capability and the read-out function of the 4155/4156.

$$\sigma = \sqrt{\sigma_n \cdot \sigma_p} = \frac{1}{v_{TH} \cdot n_i} \cdot \frac{|V_{GH} - V_{GL}|}{|V_{FB} - V_T|} \cdot \frac{f_0}{\sqrt{\alpha \cdot (1-\alpha)}}$$

where,

- $\sigma_n$  : Capture cross section of electrons
- $\sigma_p$  : Capture cross section of holes
- $v_{th}$  : Thermal velocity of the carriers
- $n_i$  : Intrinsic carrier concentration
- $V_{GH}$  : Pulse peak voltage
- $V_{GL}$  : Pulse base voltage
- $V_{FB}$  : Flat band voltage
- $V_T$  : Threshold voltage of the transistor
- $\alpha$  :  $t_r / (t_r + t_f)$
- $t_r$  : Pulse rise-time
- $t_f$  : Pulse fall-time

## Program Files Required

The following files are used for the triangle pulse method test:

<b>CPF</b>	Triangle pulse method sample program. IBASIC program file. ASCII format.
<b>SETUP.MES</b>	Sample setup file for this application. 4155/4156 setup file.

---

### NOTE

The sample program file and 4155/4156 setup file should be stored on your working diskette. The diskette must be inserted in the 4155/4156 built-in flexible disk drive during the program execution. The sample program loads the setup file and saves the data files to the diskette automatically.

---

## Example Measurement Result Files

The following files save example data created after executing the CPF program. The files are stored on the Sample Application Program Disk.

<b>CPF.DAT</b>	4155/4156 setup and measurement data file.
<b>CPF.ASC</b>	ASCII format file.

## Sample Setup File

The triangle pulse method sample program loads and uses the 4155/4156 setup file for the measurement. For the actual setup information of the setup file you are using, load the file using the 4155/4156 filer function, and refer to the 4155/4156 setup screen.

The following table shows the key setup screens of the SETUP.MES sample setup file.

---

### NOTE

If you change the setup information of the sample setup file for your application, load the sample setup file, change the setup, and save it as a new file.

To use the new file for the measurement, perform one of the following:

- Run the sample program, and select the File Name and Setup File softkeys, and enter the file name.
  - Edit the sample program, and change the initial value for the setup file name. See “To Change the Initial Value of Input Parameters” on page 6-36.
-



# Charge Pumping Triangular Pulse Method

<p><b>SAMPLING SETUP screen</b></p> <p>MEASURE: SAMPLING SETUP <span style="float: right;">98SEP28 00:27PM</span> Initial set-up of the charge pumping measurement</p> <table border="1" style="width: 100%; border-collapse: collapse;"> <tr> <td colspan="2">*SAMPLING PARAMETER</td> <td colspan="2">*STOP CONDITION</td> </tr> <tr> <td>MODE</td> <td>LINEAR</td> <td>ENABLE/DISABLE</td> <td>DISABLE</td> </tr> <tr> <td>INITIAL INTERVAL</td> <td>100.00ms</td> <td>ENABLE DELAY</td> <td>0.0000000 s</td> </tr> <tr> <td>NO. OF SAMPLES</td> <td>5</td> <td>NAME</td> <td></td> </tr> <tr> <td>TOTAL SAMP. TIME</td> <td>AUTO</td> <td>THRESHOLD</td> <td>0.00000000</td> </tr> <tr> <td></td> <td></td> <td>EVENT</td> <td>Val &gt; Th</td> </tr> <tr> <td></td> <td></td> <td>EVENT NO.</td> <td>1</td> </tr> </table> <p>HOLD TIME 100.0ms</p> <p>FILTER ON</p> <table border="1" style="width: 100%; border-collapse: collapse;"> <tr> <td colspan="4">*CONSTANT</td> </tr> <tr> <td>UNIT</td> <td>SMU1:HR</td> <td>SMU4:HR</td> <td></td> </tr> <tr> <td>NAME</td> <td>Vr</td> <td>Vsb</td> <td></td> </tr> <tr> <td>MODE</td> <td>V</td> <td>V</td> <td></td> </tr> <tr> <td>SOURCE</td> <td>0.0000 V</td> <td>0.0000 V</td> <td>-----</td> </tr> <tr> <td>COMPLIANCE</td> <td>100.00mA</td> <td>100.00mA</td> <td>-----</td> </tr> </table> <p>LINEAR Select Sampling Mode with softkey or rotary knob.</p> <table border="1" style="width: 100%; border-collapse: collapse;"> <tr> <td>SAMPLNG SETUP</td> <td>P6U SETUP</td> <td>MEASURE SETUP</td> <td>OUTPUT SEQ</td> <td></td> <td></td> <td>PREV PAGE</td> <td>NEXT PAGE</td> </tr> </table>	*SAMPLING PARAMETER		*STOP CONDITION		MODE	LINEAR	ENABLE/DISABLE	DISABLE	INITIAL INTERVAL	100.00ms	ENABLE DELAY	0.0000000 s	NO. OF SAMPLES	5	NAME		TOTAL SAMP. TIME	AUTO	THRESHOLD	0.00000000			EVENT	Val > Th			EVENT NO.	1	*CONSTANT				UNIT	SMU1:HR	SMU4:HR		NAME	Vr	Vsb		MODE	V	V		SOURCE	0.0000 V	0.0000 V	-----	COMPLIANCE	100.00mA	100.00mA	-----	SAMPLNG SETUP	P6U SETUP	MEASURE SETUP	OUTPUT SEQ			PREV PAGE	NEXT PAGE	<p>This setup screen sets the sampling measurement condition for the substrate current (Isb) measurement.</p> <p>LINEAR</p> <p>LOG10</p> <p>LOG25</p> <p>LOG50</p> <p>THINNED OUT</p>
*SAMPLING PARAMETER		*STOP CONDITION																																																											
MODE	LINEAR	ENABLE/DISABLE	DISABLE																																																										
INITIAL INTERVAL	100.00ms	ENABLE DELAY	0.0000000 s																																																										
NO. OF SAMPLES	5	NAME																																																											
TOTAL SAMP. TIME	AUTO	THRESHOLD	0.00000000																																																										
		EVENT	Val > Th																																																										
		EVENT NO.	1																																																										
*CONSTANT																																																													
UNIT	SMU1:HR	SMU4:HR																																																											
NAME	Vr	Vsb																																																											
MODE	V	V																																																											
SOURCE	0.0000 V	0.0000 V	-----																																																										
COMPLIANCE	100.00mA	100.00mA	-----																																																										
SAMPLNG SETUP	P6U SETUP	MEASURE SETUP	OUTPUT SEQ			PREV PAGE	NEXT PAGE																																																						
<p><b>PGU SETUP screen</b></p> <p>MEASURE: P6U SETUP <span style="float: right;">98SEP28 00:28PM</span> Initial set-up of the charge pumping measurement</p> <table border="1" style="width: 100%; border-collapse: collapse;"> <tr> <td colspan="3">*PULSE</td> </tr> <tr> <td>UNIT</td> <td>P6U1</td> <td>P6U2</td> </tr> <tr> <td>NAME</td> <td>Vg</td> <td></td> </tr> <tr> <td>PERIOD</td> <td>200us</td> <td>-----</td> </tr> <tr> <td>WIDTH</td> <td>100us</td> <td></td> </tr> <tr> <td>DELAY TIME</td> <td>0.0000 s</td> <td></td> </tr> <tr> <td>PEAK VALUE</td> <td>4.000 V</td> <td></td> </tr> <tr> <td>BASE VALUE</td> <td>-4.000 V</td> <td></td> </tr> <tr> <td>LEADING TIME</td> <td>80.0us</td> <td></td> </tr> <tr> <td>TRAILING TIME</td> <td>80.0us</td> <td></td> </tr> <tr> <td>IMPEDANCE</td> <td>LOW</td> <td></td> </tr> <tr> <td>PULSE COUNT</td> <td>FREE RUN</td> <td>-----</td> </tr> </table> <table border="1" style="width: 100%; border-collapse: collapse;"> <tr> <td colspan="3">*CONSTANT</td> </tr> <tr> <td>UNIT</td> <td>P6U1</td> <td>P6U2</td> </tr> <tr> <td>NAME</td> <td></td> <td></td> </tr> <tr> <td>SOURCE</td> <td></td> <td></td> </tr> </table> <p>0.0002 Enter P6U Pulse Period (2E-06 to 10).</p> <table border="1" style="width: 100%; border-collapse: collapse;"> <tr> <td>SAMPLNG SETUP</td> <td>P6U SETUP</td> <td>MEASURE SETUP</td> <td>OUTPUT SEQ</td> <td></td> <td></td> <td>PREV PAGE</td> <td>NEXT PAGE</td> </tr> </table>	*PULSE			UNIT	P6U1	P6U2	NAME	Vg		PERIOD	200us	-----	WIDTH	100us		DELAY TIME	0.0000 s		PEAK VALUE	4.000 V		BASE VALUE	-4.000 V		LEADING TIME	80.0us		TRAILING TIME	80.0us		IMPEDANCE	LOW		PULSE COUNT	FREE RUN	-----	*CONSTANT			UNIT	P6U1	P6U2	NAME			SOURCE			SAMPLNG SETUP	P6U SETUP	MEASURE SETUP	OUTPUT SEQ			PREV PAGE	NEXT PAGE	<p>Use this screen to set the pulse output condition used to force the gate pulse. During the sample program execution, PERIOD, WIDTH, LEADING TIME, and TRAILING TIME are automatically calculated and changed by the program using the following equations:</p> <p>PERIOD= 1/Freq          WIDTH= PERIOD× 0.5          LEADING TIME= WIDTH× 0.8          TRAILING TIME= WIDTH× 0.8</p> <p>where Freq is the pulse frequency [Hz]. For the definition of the pulse setup parameters, see the figure below.</p>				
*PULSE																																																													
UNIT	P6U1	P6U2																																																											
NAME	Vg																																																												
PERIOD	200us	-----																																																											
WIDTH	100us																																																												
DELAY TIME	0.0000 s																																																												
PEAK VALUE	4.000 V																																																												
BASE VALUE	-4.000 V																																																												
LEADING TIME	80.0us																																																												
TRAILING TIME	80.0us																																																												
IMPEDANCE	LOW																																																												
PULSE COUNT	FREE RUN	-----																																																											
*CONSTANT																																																													
UNIT	P6U1	P6U2																																																											
NAME																																																													
SOURCE																																																													
SAMPLNG SETUP	P6U SETUP	MEASURE SETUP	OUTPUT SEQ			PREV PAGE	NEXT PAGE																																																						



## To Execute the Sample Program

This procedure describes how to execute the sample program.

1. Display the SYSTEM: MISCELLANEOUS screen and set the REMOTE CONTROL COMMAND SET field to 4155/56.
2. Display the All IBASIC screen by pressing the front-panel **Display** key twice.
3. Insert a diskette containing the CPF program file and the setup file used for this test into the 4155/4156 built-in flexible disk drive.
4. Get the CPF sample program as follows:
  - a. Select the GET "" softkey.
  - b. Enter CPF as shown below.

```
GET"CPF"
```
  - c. Press the front-panel **Enter** key.
5. Press the front-panel **Run** key to execute the program.
6. To change the following measurement conditions, select the appropriate softkeys, and enter the new value:
  - File Name (select the File Name softkey)
    - Setup file name to get (enter the name of setup file if you changed)
    - ASCII data file name to save the result data (see Figure 6-11)
    - DAT file name to save the result data (see Figure 6-10)
  - Pulse Voltage (select the Pulse Voltage softkey)
    - Pulse base voltage [V]
    - Pulse peak voltage [V]
  - Pulse Frequency (select the Pulse Frequency softkey)
    - Number of frequencies
    - Measurement frequency [Hz]
  - SMU Bias (select the SMU BIAS softkey)
    - Drain and Source bias [V]
    - Substrate bias [V]
  - Device geometry and Temperature (select the Device Geometry softkey)
    - Channel width [cm]
    - Channel length [cm]
    - Temperature [K]
    - Flat band voltage [V]
    - Threshold voltage [V]
7. Connect the device as shown in Figure 6-1.
8. Select the Measure softkey to start the test.

### After the Measurement

After the measurement, the CPF program automatically does the following:

- Displays a list of the pulse frequency ( $f$ ), charge pumping current ( $I_{cp}$ ), and recombined charge ( $Q_{ss}$ ) on the All IBASIC screen.
- Changes the 4155/4156 setup information. This change is to display the  $Q_{ss}$  versus pulse frequency curve, and to extract and display the interface-state density ( $\overline{Dit}$ ) and the capture cross section ( $\sigma$ ). To review changes to the setup file, see the table below.
- Displays the  $Q_{ss}$  versus pulse frequency curve on the GRAPH/LIST: GRAPHICS screen. See Figure 6-10.
- Saves the ASCII file to the diskette inserted in the 4155/4156 built-in flexible disk drive. See Figure 6-11.
- Saves the DAT file to the diskette inserted in the 4155/4156 built-in flexible disk drive.

<p><b>USER FUNCTION DEFINITION screen</b></p> <p>CHANNELS: USER FUNCTION DEFINITION      98SEP29 02:19PM Recombined Charge(Qss) vs Pulse Frequency</p> <table border="1" style="width: 100%; border-collapse: collapse; margin-top: 10px;"> <thead> <tr> <th colspan="3">*USER FUNCTION</th> </tr> <tr> <th>NAME</th> <th>UNIT</th> <th>DEFINITION</th> </tr> </thead> <tbody> <tr> <td>Q</td> <td>C</td> <td>1.60218E-19</td> </tr> <tr> <td>KT</td> <td>eV</td> <td>.02585214</td> </tr> <tr> <td>Ag</td> <td>cm<sup>2</sup></td> <td>2.5E-6</td> </tr> <tr> <td>Dit</td> <td>cm<sup>-2</sup></td> <td>@L16HL6T(EXP(1))/2/Q/KT/Ag</td> </tr> <tr> <td>CaptC</td> <td>cm<sup>2</sup></td> <td>2.91247176538E-16</td> </tr> </tbody> </table> <p style="margin-top: 10px;">Q Enter User Function Name. (max 6 chars.)</p> <table style="width: 100%; border: none;"> <tr> <td style="border: 1px solid black; padding: 2px;">CHANNEL DEF</td> <td style="border: 1px solid black; padding: 2px;">USER FCTN</td> <td style="border: 1px solid black; padding: 2px;">USER VAR</td> <td style="border: 1px solid black; width: 40px;"></td> <td style="border: 1px solid black; width: 40px;"></td> <td style="border: 1px solid black; width: 40px;"></td> <td style="border: 1px solid black; padding: 2px;">PREV PAGE</td> <td style="border: 1px solid black; padding: 2px;">NEXT PAGE</td> </tr> </table>	*USER FUNCTION			NAME	UNIT	DEFINITION	Q	C	1.60218E-19	KT	eV	.02585214	Ag	cm <sup>2</sup>	2.5E-6	Dit	cm <sup>-2</sup>	@L16HL6T(EXP(1))/2/Q/KT/Ag	CaptC	cm <sup>2</sup>	2.91247176538E-16	CHANNEL DEF	USER FCTN	USER VAR				PREV PAGE	NEXT PAGE	<p><math>I_{cp}</math> is deleted from the original setup, and Q, KT, Ag, Dit, and CaptC are added. Q is the electron charge, KT is <math>k \times T</math> (<math>k</math>: Boltzmann's constant, <math>T</math>: Temperature), Ag is the area of gate, Dit is the interface-state density, and CaptC is the capture cross section. The equation shown in "To Extract Interface-state Density" on page 6-18 is defined in the DEFINITION field of Dit, not in the sample program. The values for other parameters are calculated in the sample program, and automatically entered in each DEFINITION field.</p>
*USER FUNCTION																														
NAME	UNIT	DEFINITION																												
Q	C	1.60218E-19																												
KT	eV	.02585214																												
Ag	cm <sup>2</sup>	2.5E-6																												
Dit	cm <sup>-2</sup>	@L16HL6T(EXP(1))/2/Q/KT/Ag																												
CaptC	cm <sup>2</sup>	2.91247176538E-16																												
CHANNEL DEF	USER FCTN	USER VAR				PREV PAGE	NEXT PAGE																							
<p><b>DISPLAY SETUP screen</b></p> <p>DISPLAY: DISPLAY SETUP      98SEP28 01:15PM Recombined Charge(Qss) vs Pulse Frequency</p> <p>*DISPLAY MODE <b>GRAPHICS</b></p> <p>*GRAPHICS</p> <table border="1" style="width: 100%; border-collapse: collapse; margin-top: 5px;"> <thead> <tr> <th></th> <th>Xaxis</th> <th>Y1axis</th> <th>Y2axis</th> </tr> </thead> <tbody> <tr> <td>NAME</td> <td>Freq</td> <td>Qss</td> <td></td> </tr> <tr> <td>SCALE</td> <td>LOG</td> <td>LINEAR</td> <td></td> </tr> <tr> <td>MIN</td> <td>100.000000 Hz</td> <td>220.000000fC</td> <td></td> </tr> <tr> <td>MAX</td> <td>1.00000000MHz</td> <td>630.000000fC</td> <td></td> </tr> </tbody> </table> <p style="margin-top: 5px;">*GRID      *LINE PARAMETER <input type="checkbox"/> ON      <input type="checkbox"/> ON</p> <p>*DATA VARIABLES Dit CaptC</p> <p style="margin-top: 10px;">GRAPHICS Select Display Mode with softkey or rotary knob.</p> <table style="width: 100%; border: none;"> <tr> <td style="border: 1px solid black; padding: 2px;">DISPLAY SETUP</td> <td style="border: 1px solid black; padding: 2px;">ANALYSIS SETUP</td> <td style="border: 1px solid black; width: 40px;"></td> <td style="border: 1px solid black; width: 40px;"></td> <td style="border: 1px solid black; width: 40px;"></td> <td style="border: 1px solid black; padding: 2px;">PREV PAGE</td> <td style="border: 1px solid black; padding: 2px;">NEXT PAGE</td> </tr> </table>		Xaxis	Y1axis	Y2axis	NAME	Freq	Qss		SCALE	LOG	LINEAR		MIN	100.000000 Hz	220.000000fC		MAX	1.00000000MHz	630.000000fC		DISPLAY SETUP	ANALYSIS SETUP				PREV PAGE	NEXT PAGE	<p>In the original setup, the x-axis was @TIME. To measure the substrate leakage current, the y-axis was <math>I_{sb}</math>. However, to display the <math>Q_{ss}</math> versus pulse frequency curve, Freq and <math>Q_{ss}</math> are set to the x-axis and y-axis respectively. Dit and CaptC must be set to the DATA VARIABLES fields to display the <math>\overline{Dit}</math> and <math>\sigma</math> values on the GRAPH/LIST: GRAPHICS screen. The SCALE of the x-axis must be LOG to display a linear-log graph (linear for <math>Q_{ss}</math>, and log for Freq).</p>		
	Xaxis	Y1axis	Y2axis																											
NAME	Freq	Qss																												
SCALE	LOG	LINEAR																												
MIN	100.000000 Hz	220.000000fC																												
MAX	1.00000000MHz	630.000000fC																												
DISPLAY SETUP	ANALYSIS SETUP				PREV PAGE	NEXT PAGE																								

Charge Pumping  
Triangular Pulse Method

**Figure 6-10 Triangle Pulse Method Measurement Result**

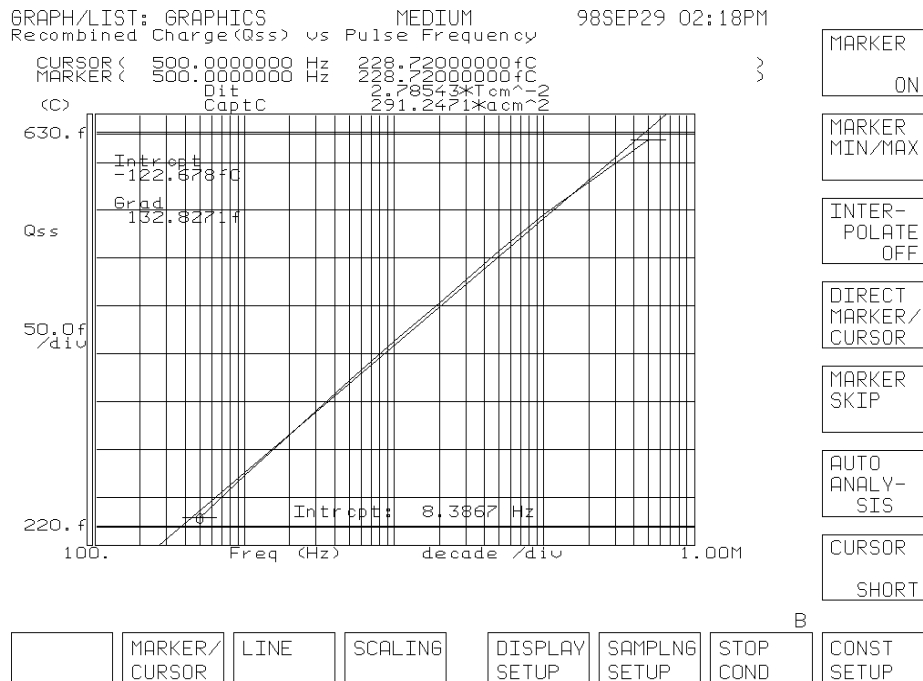

**Figure 6-11 Example Data of ASCII File**

```

10
-4, 4
.5, 0
.005, .0005, 300, -1.3, .75
500, 1000, 2000, 5000, 10000, 20000, 50000, 100000, 200000, 500000
1.1436E-10, 2.726E-10, 6.3092E-10, 1.8625E-9, 4.13682E-9, 9.06936E-9, . . . . .
2.2872E-13, 2.726E-13, 3.1546E-13, 3.725E-13, 4.13682E-13, 4.53468E-13, . . . . .
2.78543814996E+12, 2.91247176538E-16

```

In Figure 6-11, the first line is the number of frequencies.

The Second line is the pulse base voltage [V] and the pulse peak voltage [V].

The third line is the drain and source voltage [V] and the substrate voltage [V].

The fourth line is the channel width [cm], channel length [cm], temperature [K], flat band voltage [V], and the threshold voltage [V].

The fifth line and following two lines are the measurement result data; frequency ( $f$ ) [Hz], charge pumping current ( $I_{cp}$ ) [A] and recombined charge ( $Q_{ss}$ ) [C].

The last line is the mean interface-state density ( $\overline{D_{it}}$ ) and the capture cross section ( $\sigma$ ).

## Trapezoidal Pulse Method

The trapezoidal pulse method presents the energy distribution of interface-states (interface-state density ( $\overline{Dit}$ ) versus energy characteristics). This test is performed as shown in Figure 6-12. A trapezoidal pulse is applied to the gate and the substrate leakage current is measured at the point shown in Figure 6-13.

The amplitude of the trapezoidal pulse is held constant while the rise-time and the fall-time of the pulse are varied. The substrate leakage current is measured using the sampling measurement mode for each change of the pulse transient time (rise-time or fall-time). For each sampling measurement, the averaged substrate current is defined as the charge pumping current ( $I_{cp}$ ). First,  $I_{cp}$  is measured while varying the fall-time of the pulse and keeping the rise-time of the pulse constant. Next,  $I_{cp}$  is measured while varying the rise-time of the pulse and keeping the fall-time of the pulse constant. The pulse output, the sampling measurement, and the  $I_{cp}$  extraction are performed using the setup information in the 4155/4156 measurement setup file, not in the sample program.

The pulse transient time is increased with each iteration of the measurement loop. Then the interface-state density  $\overline{Dit}$  versus energy characteristics is drawn. The value of  $\overline{Dit}$  and energy is calculated by the program.

## To Extract Interface-state Density

The energy distribution of interface-states is obtained by the following equations.

$$E1 = E_i + k \cdot T \cdot \ln\left(v_{th} \cdot \sigma_p \cdot n_i \cdot \frac{|V_{FB} - V_T|}{|V_{GH} - V_{GL}|} \cdot t_r\right)$$

$$\overline{Dit1} = \frac{t_r}{q \cdot Ag \cdot k \cdot T \cdot f} \cdot \frac{dI_{cp}}{dt_r}$$

$$E2 = E_i - k \cdot T \cdot \ln\left(v_{th} \cdot \sigma_n \cdot n_i \cdot \frac{|V_{FB} - V_T|}{|V_{GH} - V_{GL}|} \cdot t_f\right)$$

$$\overline{Dit2} = \frac{t_f}{q \cdot Ag \cdot k \cdot T \cdot f} \cdot \frac{dI_{cp}}{dt_f}$$

where,

- E1** : Energy below the intrinsic level (eV)
- E2** : Energy over the intrinsic level (eV)
- E<sub>i</sub>** : Intrinsic level. Center level of the forbidden band. (eV)
- k** : Boltzmann's constant
- T** : Temperature
- v<sub>th</sub>** : Thermal velocity of the carriers
- σ<sub>p</sub>** : Capture cross section of holes
- σ<sub>n</sub>** : Capture cross section of electrons
- n<sub>i</sub>** : Intrinsic carrier concentration
- V<sub>FB</sub>** : Flat band voltage
- V<sub>T</sub>** : Threshold voltage of the transistor
- V<sub>GH</sub>** : Pulse peak voltage
- V<sub>GL</sub>** : Pulse base voltage
- t<sub>r</sub>** : Pulse rise-time
- t<sub>f</sub>** : Pulse fall-time
- $\overline{Dit1}$**  : Interface-state density for E1 (cm<sup>-2</sup> eV<sup>-1</sup>)
- $\overline{Dit2}$**  : Interface-state density for E2 (cm<sup>-2</sup> eV<sup>-1</sup>)
- q** : Electron charge
- Ag** : Channel area of the transistor
- f** : Pulse frequency
- I<sub>cp</sub>** : Charge pumping current

Figure 6-12 Flowchart of Trapezoidal Pulse Method

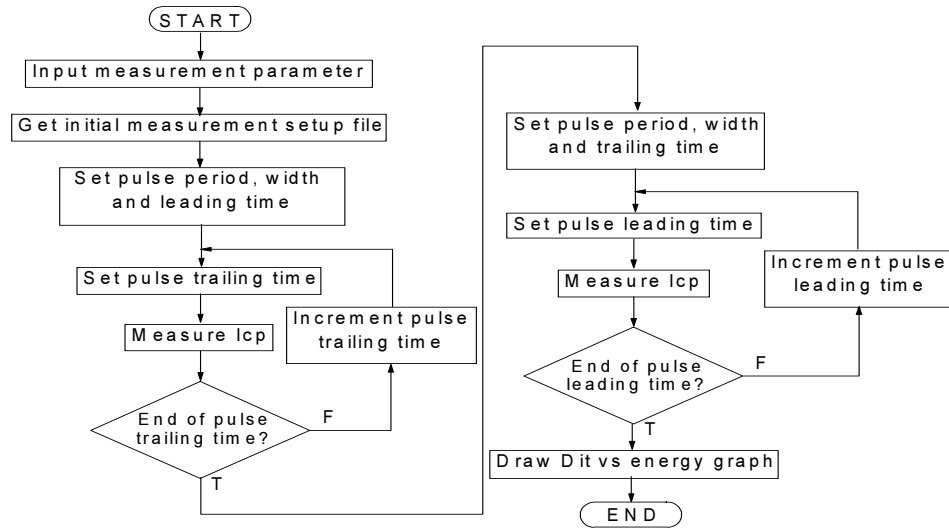
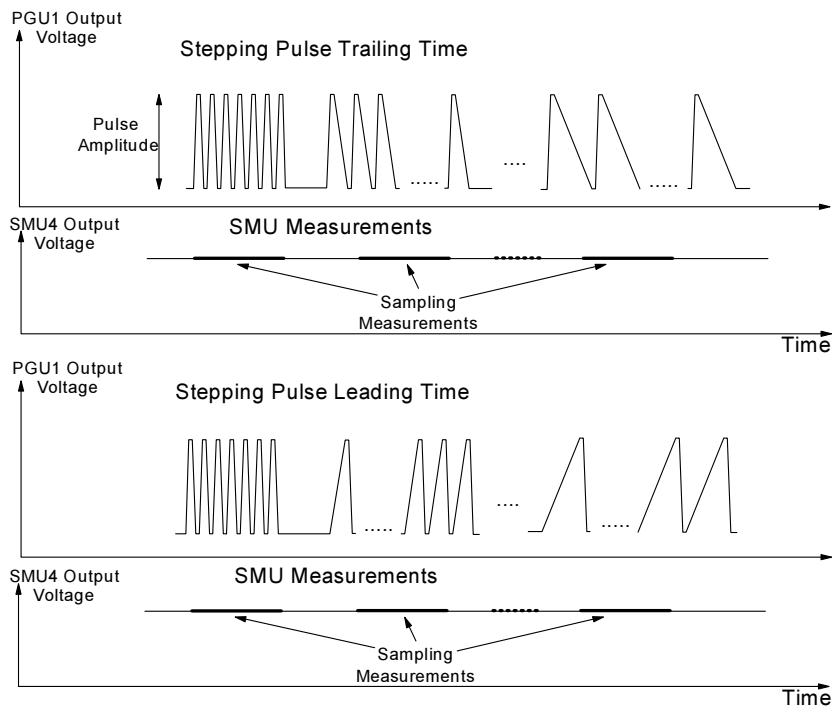

Figure 6-13 Timing Chart of Trapezoidal Pulse Method



## Program Files Required

The following files are used for the trapezoidal pulse method test:

<b>CPDIST</b>	Trapezoidal pulse method sample program. IBASIC program file. ASCII format.
<b>SETUP.MES</b>	Sample setup file for this application. 4155/4156 setup file.

---

### NOTE

The sample program file and the 4155/4156 setup file should be stored on your working diskette. The diskette must be inserted in the 4155/4156 built-in flexible disk drive during program execution. The sample program loads the setup file and saves the data files on the diskette automatically.

---

## Example Measurement Result Files

The following files save example data created after executing the CPDIST program. The files are stored on the Sample Application Program Disk.

<b>CPFD.DAT</b>	4155/4156 setup and measurement data file.
<b>CPFD.ASC</b>	ASCII format file.

## Sample Setup File

The trapezoidal pulse method sample program loads and uses the 4155/4156 setup file for the measurement. Load the setup file using the 4155/4156 filer function, and refer to the 4155/4156 setup screen to view the actual setup information you are using.

The following table shows the key setup screens of the SETUP.MES sample setup file.

---

### NOTE

If you change the setup information of the sample setup file for your application, load the sample setup file, change the setup, and save it as a new file.

To use the new file for the measurement, perform one of the following:

- Run the sample program, and select the File Name and Setup File softkeys, and enter the file name.
  - Edit the sample program, and change the initial value for the setup file name. See “To Change the Initial Value of Input Parameters” on page 6-36.
-



# Charge Pumping Trapezoidal Pulse Method

### PGU SETUP screen

MEASURE: P6U SETUP 98SEP28 00:28PM  
Initial set-up of the charge pumping measurement

*PULSE		
UNIT	P6U1	P6U2
NAME	Vg	
PERIOD	200us	-----
WIDTH	100us	
DELAY TIME	0.0000 s	
PEAK VALUE	4.000 V	
BASE VALUE	-4.000 V	
LEADING TIME	80.0us	
TRAILING TIME	80.0us	
IMPEDANCE	LOW	
PULSE COUNT	FREE RUN	-----

*CONSTANT		
UNIT	P6U1	P6U2
NAME		
SOURCE		

0.0002  
Enter P6U Pulse Period (<2E-06 to 10').

SAMPLING SETUP
P6U SETUP
MEASURE SETUP
OUTPUT SEQ
PREV PAGE
NEXT PAGE

This setup screen sets the pulse output condition used to force the gate pulse. During the sample program execution, PERIOD, WIDTH, LEADING TIME, and TRAILING TIME are automatically calculated and changed by the program. PERIOD and WIDTH are calculated as shown below:

$$\text{PERIOD} = 1/\text{Freq}$$

$$\text{WIDTH} = T_{\text{peak}} + T_{\text{lead}}/0.8$$

where Freq is the pulse frequency,  $T_{\text{peak}}$  is the pulse peak hold time, and  $T_{\text{lead}}$  is the pulse leading time. When the pulse rise-time is constant,  $T_{\text{lead}}$  is the constant transient time defined in the program. For the definition of the pulse setup parameters, see the figure below.

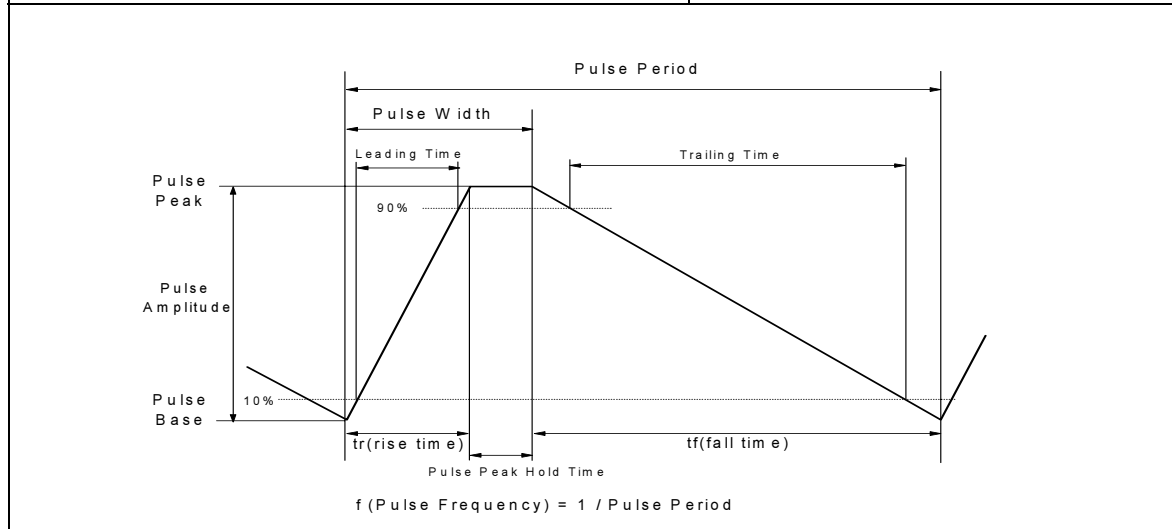

### DISPLAY SETUP screen

DISPLAY: DISPLAY SETUP 98SEP28 00:29PM  
Initial set-up of the charge pumping measurement

\*DISPLAY MODE  
GRAPHICS

\*GRAPHICS

	Xaxis	V1axis	V2axis
NAME	@TIME	Isb	
SCALE	LINEAR	LOG	
MIN	0.000000000 s	1 fA	
MAX	1.00000 s	100.0000000mA	

\*GRID  ON

\*LINE PARAMETER  ON

\*DATA VARIABLES  
Icp

GRAPHICS  
Select Display Mode with softkey or rotary knob.

DISPLAY SETUP
ANLYSIS SETUP
PREV PAGE
NEXT PAGE

This setup screen sets the measurement and display parameters. For the sampling measurement, the x-axis must be set to @TIME. To measure the substrate current, the y-axis must be set to Isb. Icp must be set to the DATA VARIABLES field to display the Icp value on the GRAPH/LIST: GRAPHICS screen.

## To Execute the Sample Program

This procedure describes how to execute the sample program.

1. Display the SYSTEM: MISCELLANEOUS screen and set the REMOTE CONTROL COMMAND SET field to 4155/56.
2. Display the All IBASIC screen by pressing the front-panel **Display** key twice.
3. Insert a diskette containing the CPDIST program file and the setup file used for this test into the 4155/4156 built-in flexible disk drive.
4. Get the CPDIST sample program as follows:
  - a. Select the GET "" softkey.
  - b. Enter CPDIST as shown below.

```
GET"CPDIST"
```
  - c. Press the front-panel **Enter** key.
5. (Optional) To change the following measurement conditions, edit the program. See “To Change the Initial Value of Input Parameters” on page 6-36.
  - Pulse peak hold time [sec]
  - Pulse trailing time [sec]
  - Constant transient time [sec] used to set the constant rise/fall time
6. Press the front-panel **Run** key to execute the program.
7. To change the following measurement conditions, select the appropriate softkeys, and enter the new value:
  - File Name (select the File Name softkey)
    - Setup file name to get (enter the name of setup file if you changed)
    - ASCII data file name to save the result data (see Figure 6-15)
    - DAT file name to save the result data (see Figure 6-14)
  - Measurement Setup (select the Meas Setup softkey)
    - Pulse base voltage [V]
    - Pulse peak voltage [V]
    - Pulse frequency [Hz]
    - Drain and Source bias [V]
    - Substrate bias [V]
    - Number of measurement points
    - Pulse transient time (pulse leading time) [sec]
  - Device parameters and Temperature (select the Device Parameter softkey)
    - Channel width [cm]
    - Channel length [cm]
    - Temperature [K]
    - Flat band voltage [V]
    - Threshold voltage [V]
    - Capture cross section [cm<sup>-2</sup>]
8. Connect device as shown in Figure 6-1.
9. Select the Measure softkey to start the test.



Figure 6-14

Trapezoidal Pulse Method Measurement Result

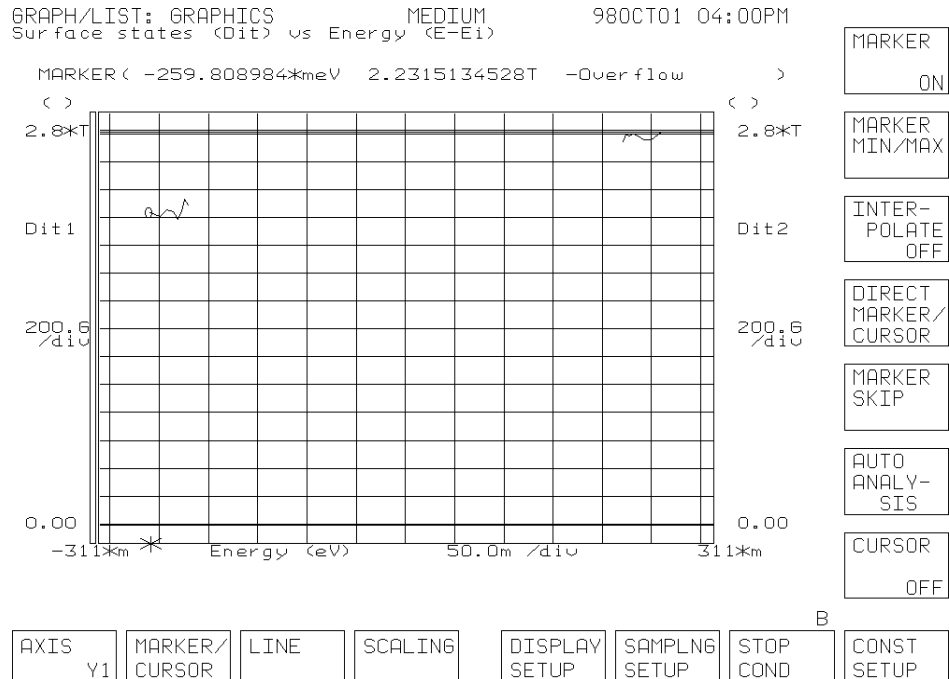

Figure 6-15

Example Data of ASCII File

```

10
-4, 4, 10000, 1.E-5, 8.E-6
.5, 0
.005, .0005, 300, -1.3, .75, 3.E-16
1.E-6, 2.E-6, 3.E-6, 4.E-6, 5.E-6, 6.E-6, 7.E-6, 8.E-6, . . . . .
1.E-5, 9.E-6, 8.E-6, 7.E-6, 6.E-6, 5.E-6, 4.E-6, 3.E-6, . . . . .
5.8114E-9, 5.6318E-9, 5.52214E-9, 5.44262E-9, . . . . .
5.16922E-9, 5.20662E-9, 5.24964E-9, 5.29638E-9, . . . . .
2.23475827E+12, 2.19234376E+12, 2.26550687E+12, . . . . .
2.79588146E+12, 2.77386300E+12, 2.80352998E+12, . . . . .
-.259808984074, -.249326843334, -.241889646121, . . . . .
.220925364642, .223970308169, .227422380425, . . . . .

```

In Figure 6-15, the first line is the number of measurement points. The second line is the pulse base voltage [V], pulse peak voltage [V], pulse frequency [Hz], pulse peak hold time [sec], and the constant transient time [sec]. The constant transient time is the pulse leading-time when the pulse rise-time is constant, and the pulse trailing-time when the pulse fall-time is constant.

The third line is the drain and source voltage [V] and the substrate voltage [V]. The fourth line is the channel width [cm], channel length [cm], temperature [K], flat band voltage [V], threshold voltage [V], and the capture cross section [cm<sup>-2</sup>].

The fifth line is the pulse leading-time [sec] when the pulse rise-time is varied. The sixth line is the pulse trailing-time [sec] when the pulse fall-time is varied. The seventh line is the charge pumping current when pulse rise-time is varied. The eighth line is the charge pumping current when pulse fall-time is varied. The ninth is the  $\overline{Dit}$ . The tenth is the  $\underline{Dit}$ . The 11th is the energy (E1). The last line is the energy (E2).

## Program Modification Examples

This section includes examples for modifying the sample program, and covers the following modification examples:

- “To Change the Initial Value of Input Parameters”
- “To Change the Measurement Unit”
- “To Change the Destination of the File Operation”

### To Change the Initial Value of Input Parameters

If you want to change the initial value of the input parameters shown below, edit the program, and change the value.

#### CPV Sample Program Input Parameters

Input Parameter	Variable Name	Initial Value in original program	Program Line No.
Pulse Amplitude	Pulse_amp	6 V	640
Pulse Base Start Voltage	Pulse_start	-9 V	650
Pulse Base Stop Voltage	Pulse_stop	2 V	660
Pulse Base Step Voltage	Pulse_step	1 V	670
Pulse Period	Pulse_period	2.E-6 sec	740
Pulse Width	Pulse_width	1.E-6 sec	750
Pulse Leasing Time	Pulse_lead	1.E-7 sec	760
Pulse Trailing Time	Pulse_trail	1.E-7 sec	770
Drain and Source Voltage	Drain_source_v	0.5 V	800
Substrate Voltage	Sub_v	0 V	810
Channel Width	Weff	0.005 cm	840
Channel Length	Leff	0.0005 cm	850
Measurement Setup File	Setup_file\$	"CHP.MES"	890
Measurement Result ASCII File	Save_ascii\$	"CHP.ASC"	920
Measurement Result DAT File	Save_data\$	"CHP.DAT"	950

Original program lines to set the initial value:

```

520 ! ----- Input Parameters -----
530 !
540 ! ----- GPIB Setup -----
550 INTEGER Hpib_addr,Swm_sc,Swm_addr
560 !
570 Hpib_sc=8           ! 415X GPIB Select Code
580 Hpib_addr=0        ! 415X GPIB Address
590 !
600 ASSIGN @Hp415x TO Hpib_sc*100+Hpib_addr
610 ASSIGN @Form_off TO Hpib_sc*100+Hpib_addr;FORMAT OFF
620 !
630 ! ----- Pulse Voltage Conditions -----
640 Pulse_amp=6        ! Pulse Amplitude Voltage
650 Base_start=-9      ! Start Pulse Base Voltage
660 Base_stop=2        ! Stop Pulse Base Voltage
670 Base_step=1        ! Step Pulse Base Voltage
680 !
690 No_of_step=INT((Base_stop-Base_start)/Base_step)+1 !No.of steps
700 REDIM V_base(1:No_of_step)
710 REDIM Isb(1:No_of_step)
720 !
730 ! ----- Pulse Timing Conditions -----
740 Pulse_period=2.E-6 ! Pulse Period
750 Pulse_width=1.E-6  ! Pulse Width
760 Pulse_lead=1.E-7   ! Pulse Leading Time
770 Pulse_trail=1.E-7  ! Pulse Trailing Time
780 !
790 ! ----- Bias Conditions -----
800 Drain_source_v=.5  ! Drain and Source Voltage
810 Sub_v=0            ! Substrate Voltage
820 !
830 ! ----- Device geometry -----
840 Weff=.005          ! Channel width [cm]
850 Leff=.0005         ! Channel length [cm]
860 !
870 ! ----- Definition of measurement and stress setup files -----
880 !
890 Setup_file$="CHP.MES" ! Charge Pumping Test Setup file
900 !
910 ! ----- File name to save ASCII data -----
920 Save_ascii$="CHP.ASC" ! Charge Pumping Test Data ASCII file
930 !
940 ! ----- File name to save GRAPHICS data -----
950 Save_data$="CHP.DAT"  ! Charge Pumping Test Data file
960 !

```

### CPF Sample Program Input Parameters

Input Parameter	Variable Name	Initial Value in original program	Program Line No.
Pulse Base Voltage	Pulse_base	-4 V	660
Pulse Peak Voltage	Pulse_peak	4 V	670
Number of Frequencies	No_of_freq	10	700
Pulse Frequency	Pulse_freq(*)	See below. <sup>a</sup>	710 to 780
Drain and Source Voltage	Drain_source_v	0.5 V	810
Substrate Voltage	Sub_v	0 V	820
Channel Width	Weff	0.005 cm	850
Channel Length	Leff	0.0005 cm	860
Temperature	T	300 K	870
Flat Band Voltage	Vfb	-1.3 V	880
Threshold Voltage	Vt	0.75 V	890
Measurement Setup File	Setup_file\$	"SETUP.MES"	990
Measurement Result ASCII File	Save_ascii\$	"CPF.ASC"	1020
Measurement Result DAT File	Save_data\$	"CPF.DAT"	1050

a. 500, 1k, 2k, 5k, 10k, 20k, 50k, 100k, 200k, 500k [Hz]

Original program lines to set the initial value:

```

540 ! ----- Input Parameters -----
550 !
560 ! ----- GPIB Setup -----
570 INTEGER Hpib_addr,Swm_sc,Swm_addr
580 !
590 Hpib_sc=8          ! 415X GPIB Select Code
600 Hpib_addr=0       ! 415X GPIB Address
610 !
620 ASSIGN @Hp415x TO Hpib_sc*100+Hpib_addr
630 ASSIGN @Form_off TO Hpib_sc*100+Hpib_addr;FORMAT OFF
640 !
650 ! ----- Pulse Voltage Conditions -----
660 Pulse_base=-4     ! Pulse Base Voltage
670 Pulse_peak=4      ! Pulse Peak Voltage
680 !
690 ! ----- Pulse Frequency -----
700 No_of_freq=10
710 Freq_data: !
720 DATA 5E2,1E3,2E3,5E3,1E4,2E4,5E4,1E5,2E5,5E5
730 !
740 REDIM Pulse_freq(1:No_of_freq)
750 REDIM Icp(1:No_of_freq),Qss(1:No_of_freq)
760 RESTORE Freq_data
770 !
780 READ Pulse_freq(*)
790 !
800 ! ----- Bias Conditions -----
810 Drain_source_v=.5 ! Drain and Source Voltage
820 Sub_v=0           ! Substrate Voltage
830 !
840 ! ----- Device geometry and temperature -----
850 Weff=.005         ! Channel width [cm]
860 Leff=.0005        ! Channel length [cm]
870 T=300             ! Temperature [K]
880 Vfb=-1.3          ! Flat band voltage [V]
890 Vt=.75            ! Threshold voltage [V]
900 !
910 ! ----- Constants -----
920 Q=1.60218E-19     ! Electronic charge [C]
930 K=8.61738E-5      ! Boltzmann's constant [ev/K]
940 Ni=1.45E+10       ! Intrinsic carrier concentration of Si at 300
K [cm^-3]
950 Nuth=1.55E+7      ! Thermal verocity of carriers
960 !
970 ! ---- Definition of measurement and stress setup files -----
980 !
990 Setup_file$="SETUP.MES" ! Charge Pumping Test Setup file
1000 !
1010 ! ----- File name to save ASCII data -----
1020 Save_ascii$="CPF.ASC" ! Charge Pumping Test Data ASCII file
1030 !
1040 ! ----- File name to save GRAPHICS data -----
1050 Save_data$="CPF.DAT" ! Charge Pumping Test Data file
1060 !

```

### CPDIST Sample Program Input Parameters

Input Parameter	Variable Name	Initial Value in original program	Program Line No.
Pulse Base Voltage	Pulse_base	-4 V	670
Pulse Peak Voltage	Pulse_peak	4 V	680
Pulse Frequency	Pulse_freq	10 kHz	690
Pulse Peak Hold Time <sup>a</sup>	Peak_hold	10 μsec	700
Constant Transient Time <sup>b</sup>	Fix_trans	8 μsec	710
Number of Measurement Points	No_of_meas	10	740
Pulse Leading Time (Varied)	Pulse_lead(*)	See below. <sup>c</sup>	810
Pulse Trailing Time (Varied)	Pulse_trail(*)	See below. <sup>d</sup>	830
Drain and Source Voltage	Drain_source_v	0.5 V	920
Substrate Voltage	Sub_v	0 V	930
Channel Width	Weff	0.005 cm	960
Channel Length	Leff	0.0005 cm	970
Temperature	T	300 K	980
Flat Band Voltage	Vfb	-1.3 V	990
Threshold Voltage	Vt	0.75 V	1000
Capture Cross Section	Cap_cross	300a cm <sup>-2</sup>	1010
Measurement Setup File	Setup_file\$	"SETUP.MES"	1110
Measurement Result ASCII File	Save_ascii\$	"CPFD.ASC"	1140
Measurement Result DAT File	Save_data\$	"CPFD.DAT"	1170

- a. Pulse peak hold time is the time which the pulse peak value continues.
- b. Constant transient time ( $t_{const}$ ) is used to calculate the constant pulse rise-time ( $t_{cr}$ ) and constant pulse fall-time ( $t_{cf}$ ) .  $t_{cr} = t_{cf} = t_{const} / 0.8$
- c. 1μ, 2μ, 3μ, 4μ, 5μ, 6μ, 7μ, 8μ, 9μ, 10μ [sec]
- d. 10μ, 9μ, 8μ, 7μ, 6μ, 5μ, 4μ, 3μ, 2μ, 1μ [sec]

Original program lines to set the initial value:

```

550 ! ----- Input Parameters -----
560 !
570 ! ----- GPIB Setup -----
580 INTEGER Hpib_addr,Swm_sc,Swm_addr
590 !
600 Hpib_sc=8          ! 415X GPIB Select Code
610 Hpib_addr=0       ! 415X GPIB Address
620 !
630 ASSIGN @Hp415x TO Hpib_sc*100+Hpib_addr
640 ASSIGN @Form_off TO Hpib_sc*100+Hpib_addr;FORMAT OFF
650 !
660 ! ----- Pulse Voltage Conditions -----
670 Pulse_base=-4     ! Pulse Base Voltage
680 Pulse_peak=4      ! Pulse Peak Voltage
690 Pulse_freq=10000. ! Pulse frequency : 10 kHz. Pulse period :
100 usec
700 Peak_hold=1.E-5   ! Pulse peak hold time 10 usec
710 Fix_trans=8.E-6   ! Fixed transient time (10% to 90%)
720 !
730 ! ----- No. of Measurement -----
740 No_of_meas=10
750 REDIM Pulse_lead(1:No_of_meas),Pulse_trail(1:No_of_meas)
760 REDIM Icp_lead(1:No_of_meas),Icp_trail(1:No_of_meas)
770 REDIM Dit_lead(2:No_of_meas-1),Dit_trail(2:No_of_meas-1)
780 REDIM Energy_lead(2:No_of_meas-1),Energy_trail(2:No_of_meas-1)
790 !
800 Leading_data: !
810 DATA 1E-6,2E-6,3E-6,4E-6,5E-6,6E-6,7E-6,8E-6,9E-6,10E-6
820 Trailing_data: !
830 DATA 10E-6,9E-6,8E-6,7E-6,6E-6,5E-6,4E-6,3E-6,2E-6,1E-6
840 !
850 RESTORE Leading_data
860 READ Pulse_lead(*)
870 !
880 RESTORE Trailing_data
890 READ Pulse_trail(*)
900 !
910 ! ----- Bias Conditions -----
920 Drain_source_v=.5 ! Drain and Source Voltage
930 Sub_v=0           ! Substrate Voltage
940 !
950 ! ----- Device geometry and temperature -----
960 Weff=.005        ! Channel width [cm]
970 Leff=.0005       ! Channel length [cm]
980 T=300            ! Temperature [K]
990 Vfb=-1.3         ! Flat band voltage [V]
1000 Vt=.75          ! Threshold voltage [V]
1010 Cap_cross=3.E-16 ! Capture cross section [cm^-2]
1020 !
1030 ! ----- Constants -----
1040 Q=1.60218E-19   ! Electronic charge [C]
1050 K=8.61738E-5    ! Boltzmann's constant [ev/K]
1060 Ni=1.45E+10     ! Intrinsic carrier concentration of Si at 300
K [cm^-3]
1070 Nuth=1.55E+7    ! Thermal verocity of carriers
1080 !
1090 ! ----- Definition of measurement and stress setup files -----
1100 !
1110 Setup_file$="SETUP.MES" ! Charge Pumping Test Setup file
1120 !
1130 ! ----- File name to save ASCII data -----
1140 Save_ascii$="CPFD.ASC" ! Charge Pumping Test Data ASCII file
1150 !
1160 ! ----- File name to save GRAPHICS data -----
1170 Save_data$="CPFD.DAT" ! Charge Pumping Test Data file
1180 !

```

## To Change the Measurement Unit

The original code in the sample program uses SMU1, SMU4, and PGU1 for the measurement. Other combinations of measurement units can be used, such as a combination of SMU2, SMU3, and PGU2.

Modification example shown below uses:

- SMU2 instead of SMU1 (to force drain voltage and source voltage)
- SMU3 instead of SMU4 (to force substrate voltage and to measure current)
- PGU2 instead of PGU1 (to force gate pulse)

1. Change the setup file as follows:

- Get the original setup file (CPV.MES for CPV sample program, or SETUP.MES for CPF and CPDIST sample programs).
- Display the CHANNELS: CHANNEL DEFINITION screen.
- Move the field pointer to the SMU1 VNAME field, and select the CHANNEL ASSIGN softkey. Then the pointer moves to the SMU1 UNIT field.
- Select a softkey for every UNIT. See the table below:

UNIT name before change	Softkey	UNIT name after change
SMU1	SMU2	SMU2
SMU2	SMU1	SMU1
SMU3	SMU4	SMU4
SMU4	SMU3	SMU3
PGU1	PGU2	PGU2
PGU2	PGU1	PGU1

- Select the EXIT CHANNEL ASSIGN softkey.
- Save the MES data as a new file, for example, NEW.MES, when it is stored on your working diskette the sample program is saved also.

2. Change the program as follows:

- a. Edit the following program line to change the measurement setup file name. The modification example shown below changes the name to NEW.MES.

Program Name	Program Line No.
CPV	890
CPF	990
CPDIST	1110

Example: Following example modifies the CPV program.

```
890 Setup_file$="NEW.MES"
```

- b. Edit the following program lines to change the SMU channels (SMU1 to SMU2, and SMU4 to SMU3).

Program Name	Program Line No.
CPV	3770 and 3780
CPF	3770 and 3780
CPDIST	4230 and 4240

Example: Following example modifies the CPV program.

```
3770 OUTPUT @Hp415x;":PAGE:MEAS:SAMP:CONS:SMU2:SOUR ";Drain_
source_v
3780 OUTPUT @Hp415x;":PAGE:MEAS:SAMP:CONS:SMU3:SOUR ";Sub_v
```

- c. Edit the following program lines to change the PGU channel (PGU1 to PGU2).

Program Name	Program Line No.
CPV	5830 to 5860, 5920 to 5930
CPF	6150 to 6180, 6250 to 6260
CPDIST	7160 to 7190, 7260 to 7270

Example: Program lines marked >> are modified. This modifies the CPV program.

```

5790 Set_pulse_time:SUB Set_pulse_time
5800     COM @Hp415x,@Form_off,INTEGER Hpib_sc
5810     COM /Condition2/ REAL Pulse_period,Pulse_width,Puls
e_lead,Pulse_trail
5820     !
>> 5830     OUTPUT @Hp415x;":PAGE:MEAS:PGUS:PULS:PGU2:PER ";Pul
se_period
>> 5840     OUTPUT @Hp415x;":PAGE:MEAS:PGUS:PULS:PGU2:WIDT ";Pu
lse_width
>> 5850     OUTPUT @Hp415x;":PAGE:MEAS:PGUS:PULS:PGU2:LEAD ";Pu
lse_lead
>> 5860     OUTPUT @Hp415x;":PAGE:MEAS:PGUS:PULS:PGU2:TRA ";Pul
se_trail
5870     SUBEND
5880     !
5890 Set_pulse_volt:SUB Set_pulse_volt(Pulse_base,Pulse_pea
k)
5900     COM @Hp415x,@Form_off,INTEGER Hpib_sc
5910     !
>> 5920     OUTPUT @Hp415x;":PAGE:MEAS:PGUS:PULS:PGU2:BASE ";Pu
lse_base
>> 5930     OUTPUT @Hp415x;":PAGE:MEAS:PGUS:PULS:PGU2:PEAK ";Pu
lse_peak
5940     SUBEND

```

## To Change the Destination of the File Operation

The sample program loads the measurement setup file from the diskette in the 4155B/4156B built-in flexible disk drive. After the measurement, the sample program also saves the measurement result DAT file and the ASCII measurement result data file on the diskette.

You can use an NFS mounted disk drive instead of the built-in flexible disk drive. To change the drive, modify the program as shown below. After the modification, the program loads the measurement setup file from the NET1 drive, saves the measurement result DAT file on the NET1 drive, and saves the ASCII measurement result data file onto both the diskette and the NET1 drive. NET1 is one of the network drives defined in the NETWORK DRIVE SETUP table on the SYSTEM: MISCELLANEOUS screen (you can define maximum 4 network drives using the table).

---

### NOTE

To save the ASCII measurement result data file onto an NFS mounted drive, the ASCII data must be previously saved on the diskette.

The IBASIC program cannot write the ASCII data directly to the NFS mounted drive.

1. To change the drive used to load the measurement setup file, insert the following program lines.

Program Line (Command)	Program Name	Program Line No.
OUTPUT @Hp415x;":MMEM:DEST NET1"	CPV	3731
	CPF	3721
	CPDIST	4181
OUTPUT @Hp415x;":MMEM:DEST INT"	CPV	3741
	CPF	3731
	CPDIST	4191

Example: Program lines marked >> are inserted. This modifies the CPV program.

```

3710      !
3720      ! Load setup file, and set bias conditions
3730      !
>> 3731      OUTPUT @Hp415x;":MMEM:DEST NET1"
3740      OUTPUT @Hp415x;":MMEM:LOAD:STAT 0,'"&Setup_file$&'",'D
      ISK'"
>> 3741      OUTPUT @Hp415x;":MMEM:DEST INT"
3750      Comment$="Charge Pumping Current Measurement"
3760      OUTPUT @Hp415x;":PAGE:CHAN:COMM '"&Comment$&'"
3770      OUTPUT @Hp415x;":PAGE:MEAS:SAMP:CONS:SMU1:SOUR ";Drain
      _source_v
3780      OUTPUT @Hp415x;":PAGE:MEAS:SAMP:CONS:SMU4:SOUR ";Sub_v
3790      CALL Set_pulse_time
3800      !

```

Charge Pumping  
 Program Modification Examples

- To change the drive used to save the measurement result DAT file, insert the following lines.

Program Line (Command)	Program Name	Program Line No.
OUTPUT @Hp415x;":MMEM:DEST NET1"	CPV	5181
	CPF	5501
	CPDIST	6511
OUTPUT @Hp415x;":MMEM:DEST INT"	CPV	5191
	CPF	5511
	CPDIST	6521

Example: Program lines marked >> are inserted. This modifies the CPV program.

```

5140 Save_data:SUB Save_data
5150   COM @Hp415x,@Form_off,INTEGER Hpib_sc
5160   COM /File_name1/ Setup_file$,Save_ascii$,Save_data$
5170   ! ---- Save charge pumping data to DAT file -----
5180   ON ERROR GOSUB Error
>> 5181   OUTPUT @Hp415x;":MMEM:DEST NET1"
5190   OUTPUT @Hp415x;":MMEM:STOR:TRAC DEF,'"&Save_data$&"','
      DISK' "
>> 5191   OUTPUT @Hp415x;":MMEM:DEST INT"
5200   OFF ERROR
5210   SUBEXIT
  
```

3. Follow the next steps to add a function which writes the measurement result data to an ASCII file on the NET1 network drive.
  - a. Insert the following program line.

Program Line (Command)	Program Name	Program Line No.
CALL Save_asc_net	CPV	1081
	CPF	1181
	CPDIST	1311

Example: Program lines marked >> are inserted. This modifies the CPV program.

```

970  !//////////////////// Main //////////////////////
980  !
990  ON INTR Hpib_sc CALL Err_check    ! Enables GPIB inter
rupt
1000 ENABLE INTR Hpib_sc;2
1010 !
1020 CALL Input_param                ! Input Parameters
1030 CALL Init_hp415x                ! Initialize 415X
1040 CALL Measure                    ! Measure Charge Pum
ping Current
1050 CALL Graph                      ! Draw Graph of Icp
- Pulse Base Voltage
1060 CALL Save_ascii                 ! Save ASCII file
1070 CALL Save_data                  ! Save DAT file
1080 CALL Test_end                   !
>> 1081 CALL Save_asc_net             ! Save ASCII file to
network drive
1090 DISP "HCI Degradation Test is Completed!!"
1100 !
1110 END

```

- b. Add the following program lines at the bottom of the program. This example writes the data to an ASCII file on the NET1 drive.

```

8000 Save_asc_net:SUB Save_asc_net
8010 ! USE FLEX MODE
8020  COM @Hp415x,@Form_off,INTEGER Hpib_sc
8030  COM /File_name1/ Setup_file$,Save_ascii$,Save_data$
8040  DIM Data$(250)
8050  OUTPUT @Hp415x;"US"
8060  OUTPUT @Hp415x;"SDSK 0"
8070  OUTPUT @Hp415x;"OPEN ";CHR$(39)&Save_ascii$&CHR$(39);",0"
8080  OUTPUT @Hp415x;"RD?"
8090  ENTER @Hp415x USING "-K";Data$
8100  OUTPUT @Hp415x;"CLOSE"
8110  !
8120  OUTPUT @Hp415x;"SDSK 1"
8130  OUTPUT @Hp415x;"OPEN ";CHR$(39)&Save_ascii$&CHR$(39);",1"
8140  OUTPUT @Hp415x;"WR ";Data$
8150  OUTPUT @Hp415x;"CLOSE"
8160  OUTPUT @Hp415x;":PAGE"
8170  SUBEND

```

Perform the following steps *before* executing the modified program.

1. Display the SYSTEM: MISCELLANEOUS screen, and perform the following steps:
  - a. Define the 4155B NETWORK SETUP table or the 4156B NETWORK SETUP table properly.
  - b. Move the field pointer to the NETWORK DRIVE SETUP table, and select the first softkey from the top. This softkey displays the definition for the NET1 network drive in the NETWORK DRIVE SETUP table.
  - c. Confirm the definition in the NETWORK DRIVE SETUP table.  
  
If the definition is not completed, define the setup properly and select the ADD softkey.  
  
If you want to modify the definition, define the setup properly and select the UPDATE softkey.
2. Insert a diskette containing the program file and the measurement setup file used to the test into the built-in flexible disk drive.
3. Get the setup file from the diskette.
4. Display the SYSTEM: FILER screen, and save the setup file on the NET1 network drive as shown below:
  - Move the field pointer to the DISK field, and select the softkey for the NET1 drive (softkey label is same as the LABEL in the NETWORK DRIVE SETUP table). The 4155B/4156B will mount the NET1 drive.
  - Save the setup file on the NET1 drive.
  - Move the field pointer to the DISK field, and select the FLOPPY softkey.
5. (Optional) If you do not want to save the measurement result ASCII data file on the diskette containing the program, perform the following steps:
  - Load the program from the diskette.
  - Remove the diskette.
  - Insert another diskette used to save the ASCII data file.

After the all steps shown above, you should perform the steps described in "To Execute the Sample Program". Then you can skip the step 3 which presses you to insert the diskette into the built-in flexible disk drive.



This program forces write and erase pulses, then measures Vth shift.

	<b>name</b>
Program	NOR_TEST
Setup files	ROMVTH.MES, NORWRT.STR, NORERS.STR, NANWRT.STR, NANERS.STR

This program uses NORWRT.STR and NORERS.STR stress setup files for write and erase pulses. These setup files are for NOR type flash EEPROM.

To use this program for NAND type flash EEPROM, please modify as follows to use NANWRT.STR and NANERS.STR stress setup files:

- Modify the following two lines:

```
1990   Wrt_file$="NORWRT.STR"      ! Write Stress Setup File Name
2000   Ers_file$="NORERS.STR"      ! Erase Stress Setup File Name
```

as follows:

```
1990   Wrt_file$="NANWRT.STR"      ! Write Stress Setup File Name
2000   Ers_file$="NANERS.STR"      ! Erase Stress Setup File Name
```

## Program Overview

Device connections for NOR and NAND type flash EEPROM are different.

### Device Connection for NOR type flash EEPROM

As shown in Figure 7-1, one 16440A SMU/Pulse Generator Selector is used to switch units for forcing write pulse and erase pulse, and measuring  $V_{th}$ .

Figure 7-1

Device Connection (NOR Type)

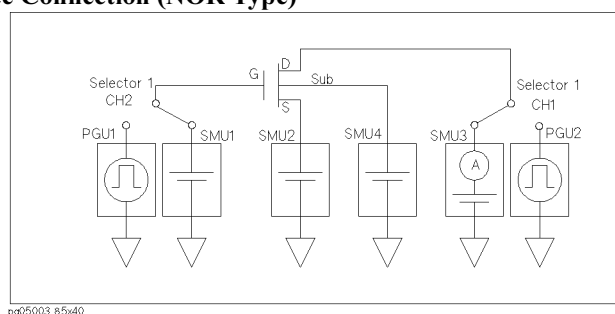

The following table shows the selector's state for each phase:

Table 7-1

Selector's State in Each Phase

Selector Channel	Write	Erase	$V_{th}$ Measure
CH1 (Drain)	PGU	PGU OPEN	SMU
CH2 (Gate)	PGU	PGU	SMU

## Device Connection for NAND type flash EEPROM

As shown in Figure 7-2, two 16440A SMU/Pulse Generator Selectors are used to switch units for forcing write pulse and erase pulse, and measuring  $V_{th}$ .

Figure 7-2

Device Connection (NAND Type)

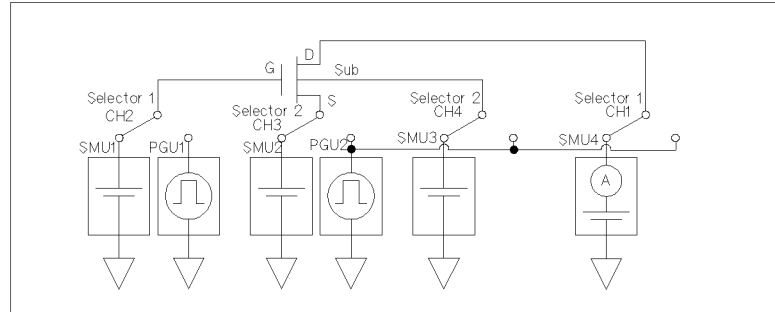

Table 7-2 shows the selector's state for each phase:

Table 7-2

Selector's State in Each Phase

Selector Channel	Write	Erase	$V_{th}$ Measure
CH1 (Drain)	PGU	PGU	SMU
CH2 (Gate)	PGU	PGU	SMU
CH3 (Source)	PGU	PGU	SMU
CH4 (Substrate)	PGU	PGU	SMU

## Main Program

The following is the main program:

```

1560 !////////// Main //////////////////////////////////////////
1570 CALL Init_hp4155
1580 ON INTR 8 CALL Err_check
1590 ENABLE INTR 8;2
1600 !
1610 CALL Test_setting
1620 CALL Get_file
1630 !
1640 Str_num=1
1650 FOR I=1 TO Meas_points
1660   CALL Stress_loop(I)
1670   IF Meas_str_num(I)>4500 THEN CALL Calibration
1680   !
1690   OUTPUT @Hp4155;":MMEM:LOAD:STAT 0,'MEM2.STR','MEMORY'"
1700   OUTPUT @Hp4155;":MMEM:LOAD:STAT 0,'MEM1.MES','MEMORY'"
1710   CALL Vth_meas("Write",I)
1720   !
1730   OUTPUT @Hp4155;":MMEM:LOAD:STAT 0,'MEM3.STR','MEMORY'"
1740   CALL Vth_meas("Erase",I)
1750   !
1760   CALL Trans_data(I)
1770   CALL Stress_graph(I)
1780   !
1790   IF Vth_w(I)<.1 OR Vth_e(I)<.1 THEN
1800     PRINT "      ### The Device is broken. Test Aborted ###"
1810     PRINT "          Final Stress Times : ";Str_num
1820     CALL Final_session
1830     STOP
1840   END IF
1850   Str_num=Str_num+1
1860 NEXT I
1870 !
1880 CALL Final_session
1890 !
1900 END

```

Line	Description
1570	initializes 4155/4156.  enables the Service Request "Enable" Register for Command, Execution, Device-dependent, and Query errors to generate service requests.
1580 and 1590	enables service request from the 4155/4156 to interrupt program.
1610	defines names of measurement setup files for Vth measurement and stress setup files for write stress and erase stress, and other stress setup.
1620	loads measurement setup file for Vth measurement and stress setup files for write and erase into internal memories.

Flash EEPROM Test  
Program Overview

<b>Line</b>	<b>Description</b>
1650	<i>Meas_points</i> is specified in subprogram "Test_setting".
1660	forces write and erase pulses. Refer to "Stress_loop" for details.
1690 and 1700	loads measurement setup file for Vth measurement and stress setup file for write pulse from internal memories.
1710	forces last write pulse, then measures Vth. Refer to "Vth_meas".
1730	loads stress setup file for erase pulse from an internal memory.
1740	forces last erase pulse, then measures Vth. Refer to "Vth_meas".
1760	transfers measurement results (Vth shifts) to the 4155/4156.
1770	displays measurement results.
1880	stores measurement results onto the diskette.

## Stress\_loop

Subprogram "Stress\_loop" to force write and erase stress is shown below:

```

2610 Stress_loop:SUB Stress_loop(INTEGER I)
2620   COM @Hp4155,@Form_off,Start_time,End_time
2630   COM /Meas_info/ INTEGER Meas_points,REAL Str,Str_num,Meas_st
r_num(*)
2640   INTEGER K
2650   REAL Str_end
2660   !
2670   OUTPUT @Hp4155;":STAT:MEAS:EVEN?"
2680   ENTER @Hp4155;K
2690   OUTPUT @Hp4155;":STAT:MEAS:ENAB 267"
2700   !
2710   OUTPUT @Hp4155;":PAGE:SCON:STAN ON"
2720   Str_end=Meas_str_num(I)-1
2730   FOR Str=Str_num TO Str_end
2740     DISP VAL$(Str);"/";VAL$(Meas_str_num(I))
2750     OUTPUT @Hp4155;"MMEM:LOAD:STAT 0,'MEM2','MEMORY';:PAGE:SCO
N:STR;*WAI"
2760     OUTPUT @Hp4155;"MMEM:LOAD:STAT 0,'MEM3','MEMORY';:PAGE:SCO
N:STR"
2770     OUTPUT @Hp4155;"*OPC?"
2780     ENTER @Hp4155;A
2790   NEXT Str
2800   !
2810   Str_num=Str
2820   OUTPUT @Hp4155;":PAGE:SCON:STAN OFF"
2830   OUTPUT @Hp4155;":STAT:MEAS:ENAB 0"
2840   SUBEND

```

Line	Description
2670 and 2680	clears the Measurement/Stress Status "Event" register.
2690	enables Bit 0 (A/D Overflow), 1 (Oscillation Status), 3 (Compliance Status), and 8 (PGU Status) of enable mask for the Measurement/Stress Status "Event" register.
2710	enables standby state so that state does <i>not</i> become idle between write and erase stress. If state becomes idle, the relay will switch after every write and erase stress, which will damage the relay.
2730 to 2790	repeats forcing write/erase pulses until one write/erase pulse before next Vth measurement.
2820	disables standby state.

## Vth\_meas

Subprogram "Vth\_meas" to force last write and erase pulses, then measure Vth:

```

2860 Vth_meas:SUB Vth_meas(Str_type$,INTEGER I)
2870     COM @Hp4155,@Form_off,Start_time,End_time
2880     COM /Meas_info/ INTEGER Meas_points,REAL Str,Str_num,Meas_st
r_num(*)
2890     COM /Meas_data/ Vth_w(*),Vth_e(*)
2900     INTEGER K
2910     !
2920     OUTPUT @Hp4155;":PAGE:SCON:STR;*OPC?"
2930     ENTER @Hp4155;A
2940     DISP Str_type$;" Times = "&VAL$(Str_num)
2950     !
2960     OUTPUT @Hp4155;":PAGE:CHAN:COMM 'Flash ROM Vth Meas. @"&Str_
type$&" Times = "&VAL$(Str_num)&"' "
2970     OUTPUT @Hp4155;":PAGE:GLIS"
2980     OUTPUT @Hp4155;":DISP ON"
2990     OUTPUT @Hp4155;":PAGE:SCON:SING;*OPC?"
3000     ENTER @Hp4155;A
3010     OUTPUT @Hp4155;":DISP OFF"
3020     OUTPUT @Hp4155;":STAT:MEAS:EVEN?"
3030     ENTER @Hp4155;K
3040     OUTPUT @Hp4155;":TRAC? 'VTH'"
3050     SELECT Str_type$
3060     CASE "Write"
3070         ENTER @Hp4155;Vth_w(I)
3080         PRINT USING "#,4X,DESZ,10X,SD.DDD";Str_num,Vth_w(I)
3090     CASE "Erase"
3100         ENTER @Hp4155;Vth_e(I)
3110         PRINT USING "10X,SD.DDD,7X,SD.DDE";Vth_e(I),Vth_w(I)-Vth_e(I)
3120     END SELECT
3130 SUBEND

```

Line	Description
2990 and 3000	executes Vth measurement and waits until completion.
3040	gets measurement result.

---

## Program Customization

This section describes how to customize program for your own application.

### Subprogram “Test\_setting”

In this subprogram, you may need to customize the following:

- Name of setup files.

If you want to use your own measurement or stress setup files, store the files on diskette, then modify the file names on the following lines:

- Measurement setup file name for Vth measurement.

```
1980 Vth_file$="ROMVTH.MES" !Vth Measurement Setup File Name
```

- Stress setup file name for write pulse.

```
1990 Wrt_file$="NORWRT.STR" !Write Stress Setup File Name
```

- Stress setup file name for erase pulse.

```
2000 Ers_file$="NORERS.STR" !Erase Stress Setup File Name
```

- File name for saving measurement results.

Following two lines create following file name for saving measurement results: *time*.DAT. To change this file name, modify these lines:

```
2010 Save_file$=TIME$(TIMEDATE) !File Name for saving measurement results
2020 Save_file$=Save_file$[1,2]&Save_file$[4,5]&Save_file$[7,7]&".DAT"
```

- Number of times to repeat measurement (FOR loop of Main Program) Following line specifies how many times to measure Vth during stress.

```
2030 Meas_points=16 !Number of times to repeat Measurement
```

- Stress pulse count data.

For example, if *Meas\_points*=4, a total of ten write/erase pulses are forced, and Vth is measured after 1st, 2nd, 5th, and 10th pulse.

```
2060 Str_num: !
2070 DATA 1, 2, 5
2080 DATA 10, 20, 50
2090 DATA 100, 200, 500
2100 DATA 1000, 2000, 5000
2110 DATA 10000, 20000, 50000
2120 DATA 100000, 200000, 500000
2130 DATA 1000000
```

## Measurement setup file for V<sub>th</sub> measurement (for NOR type)

Measurement setup for V<sub>th</sub> measurement is stored in "ROMVTH.MES" file on provided diskette. As described previously, if you use your own setup file with a different file name, change line 2000. In the ROMVTH.MES file, the following is set up. You can modify these settings in the ROMVTH.MES file or your own file:

- Gate voltage sweep setup (SMU1):

Start voltage	Stop voltage	Sweep step	Compliance
0 V	8 V	10 mV	1 nA

SMU1 is gate voltage source as shown in Figure 7-1 and Figure 7-2.

- Constant source setup:

Units	Output	Compliance
SMU2 (Source)	0 V	100 $\mu$ A
SMU3 (Drain)	100 mV	2 $\mu$ A
SMU4 (Substrate)	0 V	100 $\mu$ A

- Analysis function for V<sub>th</sub> extraction:

In this example, V<sub>th</sub> is extracted by moving marker to the point where I<sub>d</sub> is 1  $\mu$ A, then reading the voltage at that point. Refer to the following user function and auto-analysis setup.

User Function Definition:

Name	Unit	Definition
V <sub>th</sub>	V	@MX

Analysis Setup:

Setup	Definition
Marker	I <sub>d</sub> = 1 $\mu$ A
Interpolate	ON

## Stress setup file for write pulse of NOR type

Stress setup for write pulse of NOR type is stored in "NORWRT.STR" file on provided diskette. As described previously, if you use your own setup file with a different file name, change line 2010. In the NORWRT.STR file, the following is set up. You can modify these settings in the NORWRT.STR file or your own file:

- PGU1 (Gate)

Period	Width	Delay Time	Peak Value	Base Value	Leading Time	Trailing Time	Impedance
1.03 ms	1.02 ms	0.0 s	14 V	0 V	1 $\mu$ s	1 $\mu$ s	50 ohm

- PGU2 (Drain)

Period	Width	Delay Time	Peak Value	Base Value	Leading Time	Trailing Time	Impedance
Same as PGU1	1.00 ms	10 $\mu$ s	7 V	0 V	1 $\mu$ s	1 $\mu$ s	50 ohm

- Constant source setup

Unit	Source	Compliance
SMU2 (Source)	0 V	100 mA
SMU4 (Substrate)	0 V	100 mA

## Stress setup file for erase pulse of NOR type

Stress setup for erase pulse is stored on "NORERS.STR" file on provided diskette. As described previously, if you use your own setup file with a different file name, change line 2020.

In the NORERS.STR file, the following is set up. You can modify these settings in the NORERS.STR file or your own file:

- Constant source setup

Unit	Source	Compliance
SMU2 (Source) <sup>a</sup>	11 V	100 mA
SMU4 (Substrate)	0 V	100 mA

a. Erase pulse source

- Erase pulse width

Pulse width of erase pulse is specified as stress DURATION and set to 20ms.

## Stress setup file for write pulse of NAND type

Stress setup for write pulse of NAND type is stored in "NANWRT.STR" file on provided diskette. As described previously, you must change line 2010 to "NANWRT.STR" or your own custom file name. In the NANWRT.STR file, the following is set up. You can modify these settings in the NANWRT.STR file or your own file:

- PGU1 (Gate)

Period	Width	Delay Time	Peak Value	Base Value	Leading Time	Trailing Time	Impedance
413 $\mu$ s	400 $\mu$ s	0.0 s	20 V	0 V	10 $\mu$ s	10 $\mu$ s	50 ohm

- PGU2 (connected to drain, source, and substrate, and set to constant source)

Source	Impedance
0 V	50 ohm

## Stress setup file for erase pulse of NAND type

Stress setup for erase pulse of NAND type is stored in "NANERS.STR" file on provided diskette. As described previously, you must change line 2020 to "NANERS.STR" or your own custom file name. In the NANERS.STR file, the following is set up. You can modify these settings in the NANERS.STR file or your own file:

- PGU1 (connected to gate, and set to constant source)

Source	Impedance
0 V	50 ohm

- PGU2 (connected to drain, source, and substrate)

Period	Width	Delay Time	Peak Value	Base Value	Leading Time	Trailing Time	Impedance
5.02 ms	5.00 ms	0.0 s	20 V	0 V	10 $\mu$ s	10 $\mu$ s	50 ohm

## Program Listing

```

1000 !*****
1010 !*
1020 !* FILE:          NOR_TEST
1030 !* DESCRIPTION:  Program for NOR-FLASH ROM Stress Test.
1040 !*
1045 !*****
1046 Start_time=TIMEDATE
1047 ASSIGN @Hp4155 TO 800
1048 ASSIGN @Form_off TO 800;FORMAT OFF
1049 COM @Hp4155,@Form_off,Start_time,End_time
1050 COM /File_name/ Vth_file$[12],Wrt_file$[12],Ers_file$[12],Save
_file$[12]
1051 COM /Meas_info/ INTEGER Meas_points,REAL Str,Str_num,Meas_str_n
um(1:55)
1052 COM /Meas_data/ Vth_w(1:55),Vth_e(1:55)
1053 COM /Err/ Err_num(1:6),Err_message$(1:6) [50]
1054 INTEGER I
1055 !
1056 !////////// Main ////////////////////////////////////////////
1057 CALL Init_hp4155
1058 ON INTR 8 CALL Err_check
1059 ENABLE INTR 8;2
1060 !
1061 CALL Test_setting
1062 CALL Get_file
1063 !
1064 Str_num=1
1065 FOR I=1 TO Meas_points
1066     CALL Stress_loop(I)
1067     IF Meas_str_num(I)>4500 THEN CALL Calibration
1068     !
1069     OUTPUT @Hp4155;":MMEM:LOAD:STAT 0,'MEM2.STR','MEMORY'"
1070     OUTPUT @Hp4155;":MMEM:LOAD:STAT 0,'MEM1.MES','MEMORY'"
1071     CALL Vth_meas("Write",I)
1072     !
1073     OUTPUT @Hp4155;":MMEM:LOAD:STAT 0,'MEM3.STR','MEMORY'"
1074     CALL Vth_meas("Erase",I)
1075     !
1076     CALL Trans_data(I)
1077     CALL Stress_graph(I)
1078     !
1079     IF Vth_w(I)<.1 OR Vth_e(I)<.1 THEN
1080         PRINT "      ### The Device is broken. Test Aborted ###"
1081         PRINT "      Final Stress Times   : ";Str_num
1082         CALL Final_session
1083         STOP
1084     END IF
1085     Str_num=Str_num+1
1086 NEXT I
1087 !
1088 CALL Final_session
1089 !
1090 END
1091 !
1092 !////////// Sub ////////////////////////////////////////////
1093 Test_setting:SUB Test_setting
1094     COM /File_name/ Vth_file$,Wrt_file$,Ers_file$,Save_file$
1095     COM /Meas_info/ INTEGER Meas_points,REAL Str,Str_num,Meas_str
_num(*)
1096     COM /Meas_data/ Vth_w(*),Vth_e(*)
1097     !
1098     Vth_file$="ROMVTH.MES"      ! Vth Measurement Setup File Name
1099     Wrt_file$="NORWRT.STR"      ! Write Stress Setup File Name

```

Flash EEPROM Test  
Program Listing

```

2000 Ers_file$="NORERS.STR"      ! Erase Stress Setup File Name
2010 Save_file$=TIME$(TIMEDATE) ! File Name for saving measurement
results
2020 Save_file$=Save_file$[1,2]&Save_file$[4,5]&Save_file$[7,7]&"
.DAT"
2030 Meas_points=16            ! Number of times to repeat Measur
ement
2040 REDIM Meas_str_num(1:Meas_points)
2050 REDIM Vth_w(1:Meas_points),Vth_e(1:Meas_points)
2060 Str_num: !                ! Stress Pulse Count data
2070 DATA 1, 2, 5
2080 DATA 10, 20, 50
2090 DATA 100, 200, 500
2100 DATA 1000, 2000, 5000
2110 DATA 10000, 20000, 50000
2120 DATA 100000, 200000, 500000
2130 DATA 1000000
2140 RESTORE Str_num
2150 READ Meas_str_num(*)
2160 SUBEND
2170 !
2180 Init_hp4155:SUB Init_hp4155
2190 COM @Hp4155,@Form_off,Start_time,End_time
2200 !
2210 CLEAR SCREEN
2220 CLEAR @Hp4155
2230 OUTPUT @Hp4155;"*RST"
2240 OUTPUT @Hp4155;"*CLS"
2250 OUTPUT @Hp4155;":STAT:PRES"
2260 OUTPUT @Hp4155;"*ESE 60;*SRE 34;*OPC?"
2270 ENTER @Hp4155;A
2280 OUTPUT @Hp4155;":DISP:WIND:ALL BST"
2290 OUTPUT @Hp4155;":DISP OFF"
2300 PRINT " <<< Flash ROM Stress Test >>>"
2310 PRINT "Stress Times Vth Write [V] Vth Erase [V] Diff [V]"
2320 SUBEND
2330 !
2340 Get_file:SUB Get_file
2350 COM @Hp4155,@Form_off,Start_time,End_time
2360 COM /File_name/ Vth_file$,Wrt_file$,Ers_file$,Save_file$
2370 !
2380 OUTPUT @Hp4155;":MMEM:COPY '"&Vth_file$&"', 'DISK', 'MEM1.MES',
'MEMORY' "
2390 OUTPUT @Hp4155;":MMEM:COPY '"&Wrt_file$&"', 'DISK', 'MEM2.STR',
'MEMORY' "
2400 OUTPUT @Hp4155;":MMEM:COPY '"&Ers_file$&"', 'DISK', 'MEM3.STR',
'MEMORY' "
2410 SUBEND
2420 !
2430 Calibration:SUB Calibration
2440 COM @Hp4155,@Form_off,Start_time,End_time
2450 !
2460 OUTPUT @Hp4155;":PAGE:SYST:CDI"
2470 OUTPUT @Hp4155;":DISP ON"
2480 OUTPUT @Hp4155;":CAL:ALL?"
2490 ENTER @Hp4155;A
2500 SELECT A
2510 CASE 0
2520 OUTPUT @Hp4155;":PAGE:GLIS"
2530 OUTPUT @Hp4155;":DISP OFF"
2540 CASE ELSE
2550 PRINT " #### Calibration FAIL ,Test Aborted ####"
2560 CALL Final_session
2570 STOP
2580 END SELECT
2590 SUBEND
2600 !
2610 Stress_loop:SUB Stress_loop(INTEGER I)
2620 COM @Hp4155,@Form_off,Start_time,End_time
2630 COM /Meas_info/ INTEGER Meas_points,REAL Str,Str_num,Meas_str

```

```

_num(*)
2640  INTEGER K
2650  REAL Str_end
2660  !
2670  OUTPUT @Hp4155;":STAT:MEAS:EVEN?"
2680  ENTER @Hp4155;K
2690  OUTPUT @Hp4155;":STAT:MEAS:ENAB 267"
2700  !
2710  OUTPUT @Hp4155;":PAGE:SCON:STAN ON"
2720  Str_end=Meas_str_num(I)-1
2730  FOR Str=Str_num TO Str_end
2740      DISP VAL$(Str);"/";VAL$(Meas_str_num(I))
2750      OUTPUT @Hp4155;"MMEM:LOAD:STAT 0,'MEM2','MEMORY';:PAGE:SCON
:STR;*WAI"
2760      OUTPUT @Hp4155;"MMEM:LOAD:STAT 0,'MEM3','MEMORY';:PAGE:SCON
:STR"
2770      OUTPUT @Hp4155;"*OPC?"
2780      ENTER @Hp4155;A
2790  NEXT Str
2800  !
2810  Str_num=Str
2820  OUTPUT @Hp4155;":PAGE:SCON:STAN OFF"
2830  OUTPUT @Hp4155;":STAT:MEAS:ENAB 0"
2840  SUBEND
2850  !
2860  Vth_meas:SUB Vth_meas(Str_type$,INTEGER I)
2870      COM @Hp4155,@Form_off,Start_time,End_time
2880      COM /Meas_info/ INTEGER Meas_points,REAL Str,Str_num,Meas_str
_num(*)
2890      COM /Meas_data/ Vth_w(*),Vth_e(*)
2900      INTEGER K
2910      !
2920      OUTPUT @Hp4155;":PAGE:SCON:STR;*OPC?"
2930      ENTER @Hp4155;A
2940      DISP Str_type$;" Times = "&VAL$(Str_num)
2950      !
2960      OUTPUT @Hp4155;":PAGE:CHAN:COMM 'Flash ROM Vth Meas. @"&Str_
type$&" Times = "&VAL$(Str_num)&' "
2970      OUTPUT @Hp4155;":PAGE:GLIS"
2980      OUTPUT @Hp4155;":DISP ON"
2990      OUTPUT @Hp4155;":PAGE:SCON:SING;*OPC?"
3000      ENTER @Hp4155;A
3010      OUTPUT @Hp4155;":DISP OFF"
3020      OUTPUT @Hp4155;":STAT:MEAS:EVEN?"
3030      ENTER @Hp4155;K
3040      OUTPUT @Hp4155;":TRAC? 'VTH' "
3050      SELECT Str_type$
3060      CASE "Write"
3070          ENTER @Hp4155;Vth_w(I)
3080          PRINT USING "#,4X,DESZ,10X,SD.DDD";Str_num,Vth_w(I)
3090      CASE "Erase"
3100          ENTER @Hp4155;Vth_e(I)
3110          PRINT USING "10X,SD.DDD,7X,SD.DDE";Vth_e(I),Vth_w(I)-Vth_e(I)
3120      END SELECT
3130  SUBEND
3140  !
3150  Trans_data:SUB Trans_data(INTEGER I)
3160      COM @Hp4155,@Form_off,Start_time,End_time
3170      COM /Meas_info/ INTEGER Meas_points,REAL Str,Str_num,Meas_str
_num(*)
3180      COM /Meas_data/ Vth_w(*),Vth_e(*)
3190      !
3200      REDIM Meas_str_num(1:I),Vth_w(1:I),Vth_e(1:I)
3210      OUTPUT @Hp4155;":TRAC:DEL:ALL"
3220      OUTPUT @Hp4155;":TRAC:DEF 'Stress','&VAL$(I)
3230      OUTPUT @Hp4155;":TRAC:DEF 'VthWRT','&VAL$(I)
3240      OUTPUT @Hp4155;":TRAC:DEF 'VthERS','&VAL$(I)
3250      OUTPUT @Hp4155;":TRAC:UNIT 'Stress','Times' "
3260      OUTPUT @Hp4155;":TRAC:UNIT 'VthWRT','V' "
3270      OUTPUT @Hp4155;":TRAC:UNIT 'VthERS','V' "

```

Flash EEPROM Test  
Program Listing

```

3280      !
3290      OUTPUT @Hp4155;":FORM:DATA REAL,64"
3300      OUTPUT @Hp4155;":FORM:BORD NORM"
3310      OUTPUT @Hp4155;":TRAC 'Stress',#0";
3320      OUTPUT @Form_off;Meas_str_num(*),END
3330      OUTPUT @Hp4155;":TRAC 'VthWRT',#0";
3340      OUTPUT @Form_off;Vth_w(*),END
3350      OUTPUT @Hp4155;":TRAC 'VthERS',#0";
3360      OUTPUT @Form_off;Vth_e(*),END
3370      OUTPUT @Hp4155;":FORM:DATA ASCII"
3380      REDIM Meas_str_num(1:Meas_points),Vth_w(1:Meas_points),Vth_e
(1:Meas_points)
3390      SUBEND
3400      !
3410      Stress_graph:SUB Stress_graph(INTEGER I)
3420      COM @Hp4155,@Form_off,Start_time,End_time
3430      COM /Meas_info/ INTEGER Meas_points,REAL Str,Str_num,Meas_str
_num(*)
3440      !
3450      OUTPUT @Hp4155;":PAGE:CHAN:COMM 'Flash ROM Vth Shift(Stress="&
VAL$(Meas_str_num(I))&")'"
3460      OUTPUT @Hp4155;":PAGE:CHAN:UFUN:DEF 'Diff','V','VthWRT-VthERS'"
3470      !
3480      OUTPUT @Hp4155;":PAGE:DISP:GRAP:X:NAME 'Stress'"
3490      OUTPUT @Hp4155;":PAGE:DISP:GRAP:Y1:NAME 'VthWRT'"
3500      OUTPUT @Hp4155;":PAGE:DISP:GRAP:Y2:NAME 'VthERS'"
3510      OUTPUT @Hp4155;":PAGE:DISP:GRAP:X:SCAL LOG"
3520      OUTPUT @Hp4155;":PAGE:DISP:GRAP:X:MIN 1"
3530      OUTPUT @Hp4155;":PAGE:DISP:GRAP:X:MAX "&VAL$(MAX(Meas_str_num
(Meas_points),2))"
3540      OUTPUT @Hp4155;":PAGE:DISP:GRAP:Y1:SCAL LIN"
3550      OUTPUT @Hp4155;":PAGE:DISP:GRAP:Y1:MIN 0"
3560      OUTPUT @Hp4155;":PAGE:DISP:GRAP:Y1:MAX 7"
3570      OUTPUT @Hp4155;":PAGE:DISP:GRAP:Y2:SCAL LIN"
3580      OUTPUT @Hp4155;":PAGE:DISP:GRAP:Y2:MIN 0"
3590      OUTPUT @Hp4155;":PAGE:DISP:GRAP:Y2:MAX 7"
3600      !
3610      OUTPUT @Hp4155;":PAGE:DISP:DVAR:DEL 'VTH'"
3620      OUTPUT @Hp4155;":PAGE:DISP:DVAR 'Diff'"
3630      !
3640      OUTPUT @Hp4155;":PAGE:DISP:ANAL:LINE1:MODE DIS"
3650      OUTPUT @Hp4155;":PAGE:DISP:ANAL:LINE2:MODE DIS"
3660      OUTPUT @Hp4155;":PAGE:DISP:ANAL:MARK:DIS"
3670      !
3680      OUTPUT @Hp4155;":PAGE:GLIS:INT OFF"
3690      OUTPUT @Hp4155;":PAGE:GLIS:LINE OFF"
3700      OUTPUT @Hp4155;":PAGE:GLIS:MARK ON"
3710      OUTPUT @Hp4155;":PAGE:GLIS:MARK:DIR:X MAX"
3720      !
3730      OUTPUT @Hp4155;":DISP ON;:DISP OFF"
3740      SUBEND
3750      !
3760      Final_session:SUB Final_session
3770      COM @Hp4155,@Form_off,Start_time,End_time
3780      COM /File_name/ Vth_file$,Wrt_file$,Ers_file$,Save_file$
3790      COM /Meas_info/ INTEGER Meas_points,REAL Str,Str_num,Meas_str
_num(*)
3800      COM /Err/ Err_num(*),Err_message$(*)
3810      !
3820      IF Str_num-1=Meas_str_num(Meas_points) THEN
3830      Save_file$="D"&Save_file$
3840      PRINT "=====  

=====  

====="
3850      PRINT "Final Stress Times : ";Str_num-1
3860      ELSE
3870      Save_file$="F"&Save_file$
3880      END IF
3890      !
3900      PRINT "Save Data File Name : ";Save_file$
3910      PRINT "Test Duration : ";

```

```

3920     End_time=TIMEDATE
3930     PRINT DATE$(Start_time);", ";TIME$(Start_time);" ~ ";DATE$(End
_time);", ";TIME$(End_time)
3940     !
3950     DISABLE INTR 8
3960     OUTPUT @Hp4155;":MMEM:STOR:TRAC DEF,'"&Save_file$&"', 'DISK'"
3970     OUTPUT @Hp4155;":*OPC?"
3980     ENTER @Hp4155;A
3990     OUTPUT @Hp4155;":SYST:ERR?"
4000     ENTER @Hp4155;Err_num(1),Err_message$(1)
4010     IF Err_num(1)<>0 THEN PRINT "### ";Err_num(1);Err_message$(1)
; "###"
4020     !
4030     OUTPUT @Hp4155;":DISP:ALL INST"
4040     OUTPUT @Hp4155;":PAGE:GLIS"
4050     OUTPUT @Hp4155;":DISP ON"
4060     SUBEND
4070     !
4080     Err_check:SUB Err_check
4090     COM @Hp4155,@Form_off,Start_time,End_time
4100     COM /Err/ Err_num(*),Err_message$(*)
4110     INTEGER I,J
4120     !
4130     I=0
4140     REPEAT
4150         I=I+1
4160         OUTPUT @Hp4155;":SYST:ERR?"
4170         ENTER @Hp4155;Err_num(I),Err_message$(I)
4180     UNTIL Err_num(I)=0
4190     !
4200     IF I=1 THEN
4210         CALL Meas_stat_check
4220     ELSE
4230         FOR J=1 TO I-1
4240             PRINT "### ERROR Occurred ###: ";Err_num(J);Err_message$(J)
4250             DISP "### ERROR Occurred ###: ";Err_num(J);Err_message$(J)
4260         NEXT J
4270         CALL Meas_stat_check
4280         PRINT "          === Test Aborted ==="
4290         CALL Final_session
4300         STOP
4310     END IF
4320     SUBEND
4330     !
4340     Meas_stat_check:SUB Meas_stat_check
4350     COM @Hp4155,@Form_off,Start_time,End_time
4360     COM /Meas_info/ INTEGER Meas_points,REAL Str,Str_num,Meas_str
_num(*)
4370     INTEGER K
4380     !
4390     OUTPUT @Hp4155;":STAT:MEAS:EVEN?"
4400     ENTER @Hp4155;K
4410     !
4420     IF K<>0 THEN
4430         PRINT "### Abnormal Stress Status Event Occurred ###: ";K
4440         PRINT "          at Stress Number = ";Str;"[Times]"
4450         PRINT "          === Test Aborted ==="
4460         CALL Final_session
4470         STOP
4480     END IF
4490     SUBEND

```

Flash EEPROM Test  
Program Listing

---

---

**8**            **Time Dependent Dielectric Breakdown  
(TDDB)**

---

## Time Dependent Dielectric Breakdown (TDDB)

This setup forces a constant voltage to the gate until the gate oxide breakdowns or a maximum time limit is reached, then calculates the total forced electric charge.

	<b>name</b>
Program	none
Setup file	TDDB.MES

---

## Application Overview

Figure 8-1

Device Connection

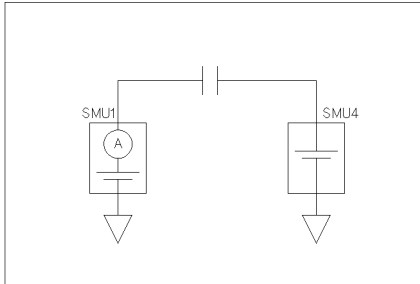

pg05002 60x40

The measurement flow is as follows:

1. Forces a constant voltage to the gate.
2. Measures gate current by sampling measurement.
3. If gate current exceeds specified threshold, measurement is stopped.
4. Calculates total electric charge that was forced by using a user function with definition `INTEG ( Ig, @TIME )`.

## Customization

Measurement setup file is stored in "TDDB.MES" file on provided diskette. In the TDDB.MES file, the following is set up. You can modify these settings in the TDDB.MES file or your own file, then use the setup for your own application.

- Constant source setup

Units	Output	Compliance
SMU1 (Gate)	20 V	1.001 $\mu$ A
SMU4 (Substrate)	0 V	100 $\mu$ A

- Sampling Parameters

Mode	Initial interval	No. of samples	Total samp. time
Thinned-out	100 ms	1001	999.9 s

- Stop Condition

This setup is used to judge the oxide breakdown. If gate current exceeds the specified threshold, measurement is stopped.

Enable Delay	Threshold
200 ms	1 $\mu$ A

---

---

**9 Electromigration**

---

## Electromigration

This setup forces a constant current to the DUT (metal), measures time-to-failure of DUT, then calculates the total forced electric charge.

	<b>name</b>
Program	none
Setup file	EM.MES

---

## Application Overview

**Figure 9-1**      **Device Connection**

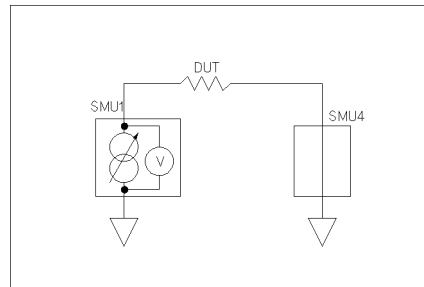

pg05005 60x40

The measurement flow is as follows:

1. Forces constant current.
2. Monitors DUT voltage by sampling measurement.
3. If the DUT voltage reaches specified threshold, the forcing stops.
4. Calculates total electric charge that was forced by using a user function with definition `INTEG (Idut1, @TIME)`.

## Customization

Measurement setup file is stored in "EM.MES" file on provided diskette. In the EM.MES file, the following is set up. You can modify these settings in the EM.MES file or your own file, then use the setup for your own application.

- Constant source setup

Units	Output	Compliance
SMU1	50 mA	20.002 V

- Sampling Parameters

Mode	Initial interval	No. of samples	Total samp. time
Linear	1 s	10001	AUTO <sup>a</sup>

a. Initial interval No. of samples

- Stop Condition

If the DUT voltage exceeds the specified threshold, measurement is stopped.

Enable Delay	Threshold
20 ms	20 V