

E5061A/E5062A Performance Test Program

<External Use Only>

Operation Manual

First Edition



Agilent Technologies

Agilent Part No. N/A

June 2008

Notices

The information contained in this document is subject to change without notice.

This document contains proprietary information that is protected by copyright. All rights are reserved. No part of this document may be photocopied, reproduced, or translated to another language without the prior written consent of Agilent Technologies.

Microsoft, MS-DOS, Windows, Visual C++ , Visual Basic , VBA and Excel are registered

UNIX is a registered trademark in U.S. and other countries, licensed exclusively through X/Open Company Limited.

Portions Copyright 1996, Microsoft Corporation. All rights reserved.

© Copyright 2008 Agilent Technologies

Manual Printing History

The manual's printing date and part number indicate its current edition. The printing date changes when a new edition is printed. (Minor corrections and updates that are incorporated at reprint do not cause the date to change.) The manual part number changes when extensive technical changes are incorporated.

June 2008 First Edition

1. Installation

| | |
|--|----|
| Warm-up for Performance Test | 6 |
| Required Equipment | 7 |
| Power Meter Accuracy Test | 9 |
| Preparation for using the E5061A/E5062A Performance Test Program | 15 |
| Required Controller | 15 |
| Installing a GPIB Card (82350A, 82340B or 82341C/D) | 15 |
| Installing Agilent VEE for Personal Computer | 15 |
| Installing Performance Test Program into Your PC | 16 |
| Equipment Setup | 17 |
| Setting Talker/Listener GPIB address of the E5061A/E5062A | 17 |
| Registering 8482A Power Sensor Calibration Data | 18 |

2. Operation

| | |
|---|----|
| How to perform the E5061A/E5062A Performance Test Program | 21 |
| Main Window Information | 27 |
| Model Number | 27 |
| Serial Number | 27 |
| Option | 27 |
| Test Name | 27 |
| Test Result Summary | 28 |

1 **Installation**

This chapter provides information for the installation of E5061A/E5062A performance test program.

Warm-up for Performance Test

Allow the E5061A/E5062A to warm up for at least 30 minutes before you execute any of the performance tests.

Required Equipment

Table 1-1 lists the recommended equipment for performing maintenance on the E5061A/E5062A.

Table 1-1 Recommended Test Equipment

| Equipment | Critical Specification | Recommended Model | Qty |
|------------------------------|--|--|------------------|
| Frequency Counter | Frequency: 50 MHz to 3 GHz Accuracy: <2.5 ppm | Agilent 53131A with Opt. 010 and 030 ^{*2} | 1 |
| Power Meter | No Substitute | Agilent E4419B with Opt. G12 or H12 ^{*2} | 1 |
| Dynamic Accuracy Test Kit | No Substitute | Agilent Z5623A Opt H01 | 1 |
| Power Sensor | No Substitute | Agilent 8482A | 1 |
| Power Sensor (75 Ω) | No Substitute | Agilent 8483A | 1 |
| Calibration Kit | No Substitute | Agilent 85032F | 1 |
| Calibration Kit (75 Ω) | No Substitute | Agilent 85036B | 1 |
| Short | Type-N(m), N(f) | Part of Agilent 85032F with Type-N adapter | 2 |
| Short (75 Ω) | Type-N(m), N(f) | Part of Agilent 85036B with Type-N adapter | 2 |
| Fixed Attenuator (6dB) | 50 ohm, N(m)-N(f), VSWR <= 1.015 | Agilent 8491A Opt.006 and H60 | 1 |
| Cable | BNC(m)-BNC(m) Cable, 30 cm BNC(m)-BNC(m) Cable, 122 cm Coaxial Cable with Type-N(m) connectors, 61 cm (24 in), 2ea Coaxial Cable with 75 Ω Type- N(m) connectors, 61 cm (24 in), 2ea | Agilent p/n 8120-1838 Agilent p/n 8120-1840 Agilent N6314A (p/n 8120-8862) Agilent p/n 8120-8898 | 1 1 1 1 |
| Adapter | N(m) 50 Ω - N(f) 75 Ω -Adapter N(m)-BNC(f) Adapter BNC(m)-BNC(m) BNC Tee (m) (f) (f) | Agilent p/n 1250-0597 Agilent p/n 1250-0780 Agilent p/n 1250-0216 Agilent p/n 1250-0781 | 1 1 1 1 |

**Installation
Required Equipment**

| Equipment | Critical Specification | Recommended Model | Qty |
|-----------------------------------|--|--------------------------|------------|
| Minimum Loss Pad | 50 Ω N(f)-75 Ω N(m) | Agilent 11852B | 1 |
| Minimum Loss Pad | 50 Ω N(m)-75 Ω N(f) | Agilent 11852B Opt. 004 | 1 |
| Torque Wrench | Size: ¾ inch Torque: 136 N-cm | Agilent p/n 8710-1766 | 1 |
| Personal Computer with GPIB board | Windows 2000 / XP, VEE 6.2 or VEE 7.xx | | 1 |

- *1. Opt.050 and Opt.124 can be substituted for Opt.030. In this case, a N(m)-BNC(f) adapter is necessary.
- *2. The accuracy of a standard E4419B of ±0.02 dB is adequate for all tests/adjustments except “Dynamic Accuracy Test”. This test requires a power meter with Option G12 or H12 that has been certified to a higher accuracy specification. If an Option G12 or H12 power meter is not available, a test is provide on “Power Meter Accuracy Test” on page 9 to verify the accuracy of a standard power meter.

Table 1-2 Alternative Test Equipment

| Equipment | Critical Specification | Recommended Model | Qty |
|-------------------|--|---|------------|
| Frequency Counter | Frequency: 50 MHz to 3 GHz Accuracy: <2.5 ppm | Agilent 53132A/181A with Opt. 010 and 030 ^{*1} | 1 |
| Short | Type-N(m) | Agilent 11512A | 1 |

- *1.Opt.050 and Opt.124 can be substituted for Opt.030. In this case, a N(m)-BNC(f) adapter is necessary.

Power Meter Accuracy Test

This test is intended for power meters used in testing the E5061A/E5062A. The “Dynamic Accuracy Test” requires the use of a power meter that has been calibrated to a higher accuracy than the standard power meter.

Power meters with options G12 and H12 specify improved instrument accuracy over a limited power range. (These power meters do not contain unique hardware.) A power meter may be returned to the factory to have one of these options added to an existing power meter or to renew the calibration for one of these options.

This test procedure is an alternative to returning the power meter to the factory. When a power meter passes this test, it is considered to be *calibrated* for the G12 or H12 option even though it has not been returned to the factory.

EPM Series Power Meters That Can Be Tested Using This Procedure

This procedure assume that the recommended model number power meter is being tested.

The alternate model numbers can be tested but the necessary procedural steps may differ.

| Recommended Model Number | Alternate Model Numbers |
|--------------------------|-------------------------|
| E4419B | E4419A |

NOTE: It is recommended that the revision number for the power meter “Main Firmware” be Ax.03.00 or higher. This applies to all power meter model numbers listed above (both recommended and alternate).

Installation
Required Equipment

Equipment Used for the Power Meter Accuracy Test

| Equipment Type | Recommended Model or Part Number | Alternate Model or Part Number |
|--|----------------------------------|---|
| Range calibrator | Agilent 11683A | None |
| Precision digital voltmeter | Agilent 3458A | Any with required accuracy and resolution* ¹ |
| Power meter cable | Agilent 11730A, p/n 8120-8319 | Any equivalent |
| Cable, BNC, 50 Ω | Any | Any |
| Adapter for connecting BNC cable to DVM inputs | Any | Any |

*1. Required accuracy and resolution at the following voltage levels:
14 mV input: 0.0100% accuracy, 10 nV resolution
0.14 V input: 0.0050% accuracy, 100 nV resolution
0.45 V input: 0.0030% accuracy, 100 nV resolution

Description of the Test

The power meter accuracy is verified for various power inputs and the actual readings are recorded in a test record. A range calibrator is used to provide the reference inputs.

NOTE: It is recommended that a copy of the test record on page 13 be made, and the values be recorded on the copy, thus preserving the original for future use.

Test Procedure

NOTE: This procedure assumes the use of the recommended equipment model numbers. The actual step required, therefore, may differ for other model numbers of equipment used.

- Step 1.** Setup the equipment as shown in Fig.
- a.** Connect the DC REFERENCE OUTPUT connector on the rear panel of the range calibrator to the DVM voltage input.
 - b.** Connect the POWER METER output of the range calibrator to the input of the power meter being tested.
 - c.** Switch on the power to the power meter, the range calibrator, and the digital voltmeter

Figure 1-1 Setup for the Power Meter Accuracy Test

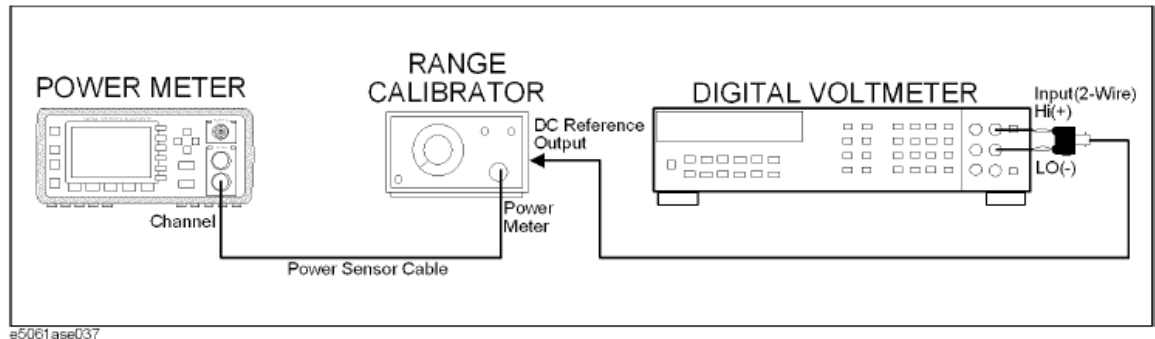

- Step 2.** Press the power meter: Press **[Preset/Local]**, then **Confirm**.
- Step 3.** Perform the following steps for each channel on the power meter:
- Set to read in dBm: Press **[dBm/W]**, then **dBm**.
 - Set the ref cal factor to 100%: Press **[Zero/Cal]**, **Cal**, **A/B Ref CF**, then set to **100.0**, if necessary.
 - Set the cal factor to 100%: Press **[Frequency/Cal Fac]**, **A/B Cal Fac**, then set to **100.0**, if necessary.
 - Set readout to 0.001 dBm: Press **[Meas Setup]**, then **Resolution 1234**, to highlight **4**.
 - Set filter step detect on and filter length to 512: Press **[System/Inputs]**, channel **A** or **B** **Input Setting**, **[More]**, **Ch A/B Filter**, **Step Det On**, **Filter On**, **Mode MAN**, **Length**, then set the filter length to **512**.
- Step 4.** Setup the digital voltmeter (DVM) as follows:
- Reset the DVM: Press the **blue key** followed by **Reset**.
 - Set the sample period to a value greater than one second: Press **NPLC**, **5**, **0**, then **Enter**.
- Step 5.** Set the range calibrator controls as follows:
- POLARITY: NORMAL
 - RANGE: 1 mW
 - FUNCTION: CALIBRATE
- Step 6.** Allow the equipment to warm up for approximately 30 minutes. Do not change any connections or control setting during this time.

Installation
Required Equipment

- Step 7.** Zero and calibrate the power meter channel to which the range calibrator is connected:
- a. The range calibrator's RANGE switch should be set to 1 mW.
 - b. Set the range calibrator's FUNCTION switch to STANDBY.
 - c. Press **[Zero/Cal]**, then **Zero A** or **Zero B** (as appropriate). Wait for the operation to complete.
 - d. Set the range calibrator's FUNCTION switch to CALIBRATE.
 - e. Press **[Zero/Cal]**, **Cal**, then **Cal A** or **Cal B** (as appropriate). Wait for the operation to complete.
- Step 8.** Monitor the drift rate of the power meter reading: Five minutes following calibration, the meter must read 0.001, 0.000, or -0.001 dBm. If the power meter reading is not one of these values, allow additional warm up time, then check the drift rate again. The range calibrator must remain connected to the power meter during this warm up time.
- Step 9.** Zero and calibrate the power meter channel to which the range calibrator is connected:

NOTE: After a channel on the power meter is calibrated, do not allow more than 5 minutes to elapse before completing the remaining measurement steps for that channel.

- a. The range calibrator's RANGE switch should be set to 1 mW.
- b. Set the range calibrator's FUNCTION switch to STANDBY.
- c. Press **[Zero/Cal]**, then **Zero A** or **Zero B** (as appropriate). Wait for the operation to be completed.
- d. Set the range calibrator's FUNCTION switch to CALIBRATE.
- e. Press **[Zero/Cal]**, **Cal**, then **Cal A** or **Cal B** (as appropriate). Wait for the operation to complete.

- Step 10.** Record the DVM voltage reading as value A in the test record on page 13.

NOTE: All DVM readings in this procedure should be recorded showing five significant digits.

- Step 11.** The reading on the power meter should be 0.000 ± 0.001 dBm.
- Step 12.** Switch the range calibrator RANGE to 300 μ W.
- Step 13.** Record the DVM voltage reading as value B in the test record.
- Step 14.** Wait for the power meter reading to settle (no settling drift within 20 seconds).
- Step 15.** Record the power meter reading as value C in the test record.
- Step 16.** Switch the range calibrator RANGE to 100 μ W.
- Step 17.** Record the DVM voltage reading as value D in the test record.
- Step 18.** Wait for the power meter reading to settle (no settling drift within 20 seconds).
- Step 19.** Record the power meter reading as value E in the test record.
- Step 20.** If testing a dual-channel power meter, perform Step 7 through Step 19 for the other channel.
- Step 21.** Perform the pass/fail calculations indicated on the test record.

NOTE: If a channel of the power meter does not pass this test, the power meter cannot be used in applications that require Option G12 or H12. There are no adjustments that can be performed to improve the performance of the power meter. Typically, replacing the A6 measurement assembly associated with the failed channel will correct the problem.

Installation
Required Equipment

TEST RECORD FOR POWER METER ACCURACY TEST

| | | | |
|---------------------------|--|------------|--|
| Power Meter Tested | | | |
| Model Number: | | Test Date: | |
| Serial Number: | | Tested By: | |

Test Equipment Used

| | | | |
|--------------------------------------|--|-------------|--|
| Range Calibrator: Model No.: | | Serial No.: | |
| Digital Voltmeter: Model No.: | | Serial No.: | |

Test Results

| Range Calibrator Setting: | Channel A | | Channel B | |
|---------------------------------|----------------------|------------------------------|----------------------|------------------------------|
| | DVM Reading (Vdc) | Power Meter Reading (dBm) | DVM Reading (Vdc) | Power Meter Reading (dBm) |
| 1 mW | A = | 0.00±0.001 | A = | 0.00±0.001 |
| 300 μW | B = | C = | B = | C = |
| 100 μW | D = | E = | D = | E = |

Pass/Fail Calculation

| | | |
|--------|--|--|
| 300 μW | $R = B/A =$ $S = 10^{(C/10)}$ $\% \text{ ERROR} = ((R-S)/R) \times 100 =$ Limits: $\pm 0.13\%$ Pass ___ Fail ___ | $R = B/A =$ $S = 10^{(C/10)}$ $\% \text{ ERROR} = ((R-S)/R) \times 100 =$ Limits: $\pm 0.13\%$ Pass ___ Fail ___ |
| 100 μW | $T = D/A =$ $U = 10^{(E/10)}$ $\% \text{ ERROR} = ((T-U)/T) \times 100 =$ Limits: $\pm 0.10\%$ Pass ___ Fail ___ | $T = D/A =$ $U = 10^{(E/10)}$ $\% \text{ ERROR} = ((T-U)/T) \times 100 =$ Limits: $\pm 0.10\%$ Pass ___ Fail ___ |

Preparation for using the E5061A/E5062A Performance Test Program

The performance test can be performed using this E5061A/E5062A Performance Test Program.

To use the Performance Test Program, some preparations are required. This section describes how to proceed.

Required Controller

The following controller system is required to run the performance test program.

| | |
|------------|---|
| Windows PC | PC-AT Compatible, RAM: 64MBytes, CPU Pentium 200 MHz or faster, HDD: 10 MBytes or more free space |
| OS | Microsoft Windows XP |
| Software | Agilent VEE Runtime (Rev. 6.2) |
| GPIB Card | 82350A, 82340B, 82341C/D |

Installing a GPIB Card (82350A, 82340B or 82341C/D)

Install a GPIB Card (82350A, 82349B or 82341C/D)

Install a GPIB Card into your computer (see the GPIB Card manual), and set the select code.

Normally, the select code of the GPIB Card is set to “7”.

If it is not recognized with “7”, it is required to try another number.

The selected “Select code” can be confirmed by checking the logical unit number in the I/O Library.

Installing Agilent VEE for Personal Computer

Install the Agilent VEE Runtime (Rev 6.2 and above) into your computer (see the Agilent VEE for Windows).

NOTE : The Performance Program Rev.A.01.20 and above is available to run on VEE 8.5x.

Installation

Preparation for using the E5061A/62A Performance Test Program

Installing Performance Test Program into Your PC

- Step 1.** Make a copy of the E5061A/E5062A performance test program named pte506162a.exe in a directory of the hard disk drive in your PC. The program is downloadable from the CTD-Kobe web site.
- Step 2.** Double-click on the filename on the Windows' Explorer to start extracting the self-extracting archive.
- Step 3.** You will be prompted to enter folder name for installing the program files. Enter the folder name, then click on UNZIP. The default folder is C:\pte506162a

Figure 1-2 Prompt of Self-extracting Achieve

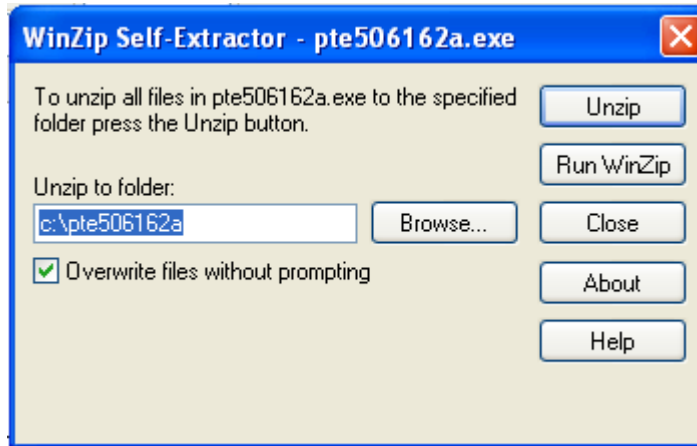

- Step 4.** Confirm the message that you have successfully extracted the files and click OK and Close.

Figure 1-3 Message Window

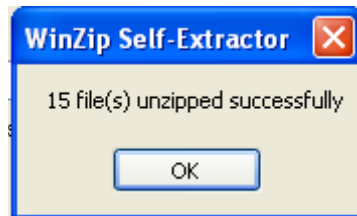

Equipment Setup

Performing performance test program requires the system described in this section. The Hardware Setup is shown in Figure 1-4.

- NOTE:** You must connect the 8482A/8483A power sensor you use to the following power meter's channel.
- 8482A Power sensor --- Connect to the channel A (for E5061A/E5062A opt. 150/250)
 - 8483A Power sensor --- Connect to the channel B (for E5061A/E5062A opt. 175/275)

Figure 1-4 Performance Test Hardware Setup

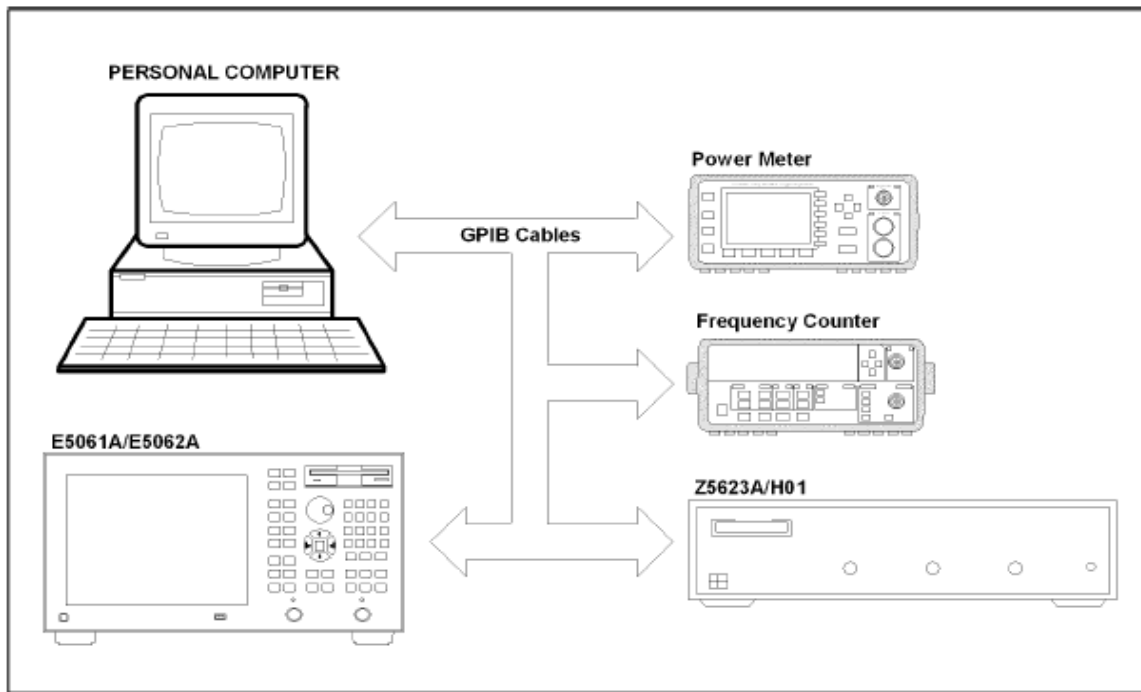

e5061apt002

Setting Talker/Listener GPIB address of the E5061A/E5062A

To control the E5061A/E5062A in the adjustment program, the talker/listener GPIB address must be set. Check and set the GPIB address according to the following procedure.

- Step 1.** Press **System** - **Misc Setup** - **GPIB Setup** - **Talker/Listener Address**. If the address "17" has not been set, proceed to the next step.
- Step 2.** Enter the GPIB address "17" using the ENTRY block keys on the front panel.

Installation

Preparation for using the E5061A/62A Performance Test Program

Registering Power Sensor Calibration Data

The calibration data of the 8482A/8483A power sensors must be registered before running the performance test program. Execute the Agilent EditCal Calibration Factor Editor to register it.

- Step 1.** Start the EditCal to click on Start button, Programs and Agilent EditCal on Windows.
- Step 2.** The top window appears as shown in Figure 1-5. Choose Calibration Data, and then press Start.

Figure 1-5 EditCal Top Window



- Step 3.** The calibration data menu appears as shown in Figure 1-6. Choose 8482A and the serial number to edit, and then click on Edit. If the serial number is not registered, Click on Add and choose 8482A.

Figure 1-6 Calibration Data Menu

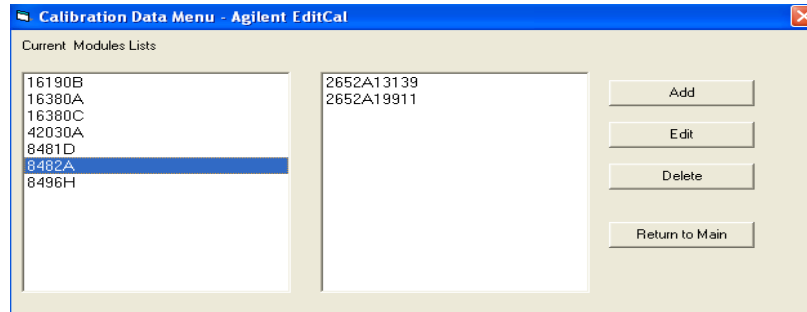

Preparation for using the E5061A/62A Performance Test Program

- Step 4.** The 8482A calibration data window appears as shown in Figure 1-7. Input the following items and click on OK.
- Serial number (for addition)
 - Calibration Date
 - Calibration Due Date
 - Calibration Data

NOTE: You must enter the reference calibration factor (Ref CF) data for power sensor in the 50 MHz frequency column.

NOTE: Delete the calibration points which are not described on the calibration report because the performance test program interpolates the calibration factor for the frequency which calibration factor is not registered.

Figure 1-7 8482A Calibration Data Window

Editing calibration data (8482A - 2652A13139)

Model Number: 8482A

Serial Number: 2652A13139

Calibration Number: 12345678

Calibration Date: 1 JAN 2005

Calibration Due Date: 1 JAN 2006

Comment: 50

Calibration Data

| Frequency [MHz] | Calibration factor[%] |
|-----------------|-----------------------|
| 0.10 | 100.0 |
| 0.30 | 100.0 |
| 1.00 | 100.0 |
| 3.00 | 100.0 |
| 10.00 | 100.0 |
| 30.00 | 100.0 |
| 50.00 | 100.0 |
| 100.00 | 100.0 |

Buttons: OK, Cancel, Add Calibration Point, Delete Calibration Point

2 **Operation**

This chapter provides information for the operation of E5061/E5062A performance test program.

How to perform the E5061A/E5062A Performance Test Program

- Step 1.** Open the Agilent Connection Expert.
- Step 2.** Check the GPIB connection availability between ETE and PC from Agilent Connection Expert. (See Figure 2-1)

Figure 2-1 Agilent Connection Expert

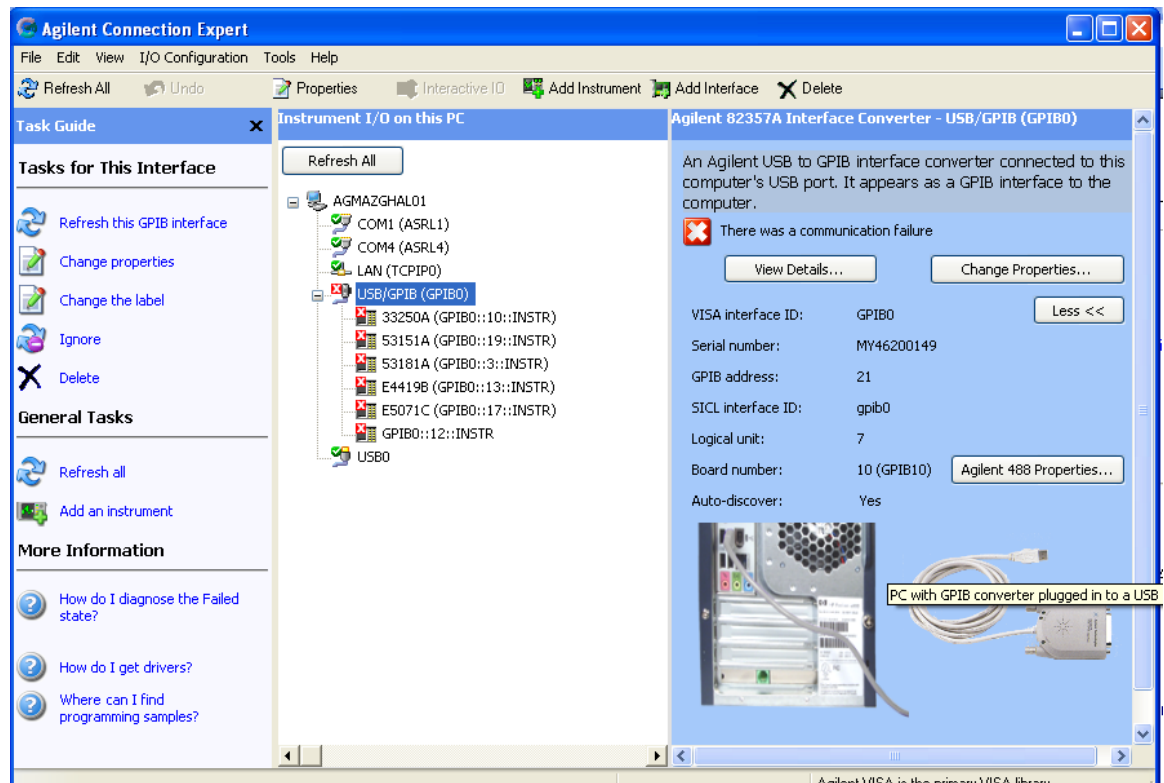

- Step 3.** Open Explore
- Step 4.** Double click ; pte5071c.vxe
- Step 5.** You may be asked to add drivers for the equipment during the program loading. Then, click OK and input the GPIB address for each equipment. Enter 0 as the address for each equipment which is not used for the performance test. (See Figure 2-2).

Operation
How to perform the E5071C Performance Test Program

Figure 2-2 Direct I/O configuration

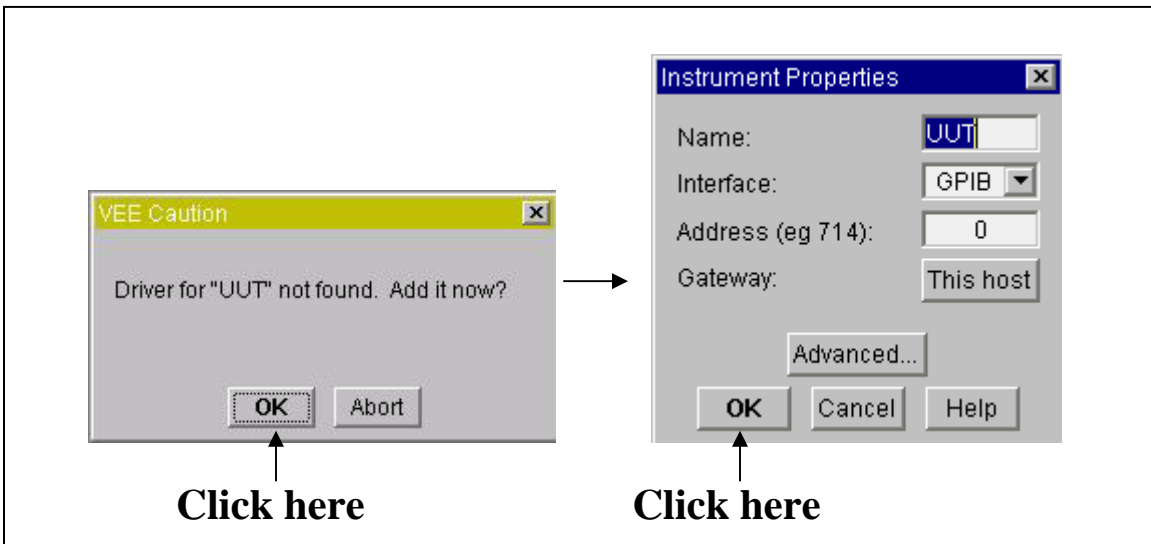

Step 6. Click START on the Agilent VEE Screen as shown in Figure 2-3.

Figure 2-3 Main Window

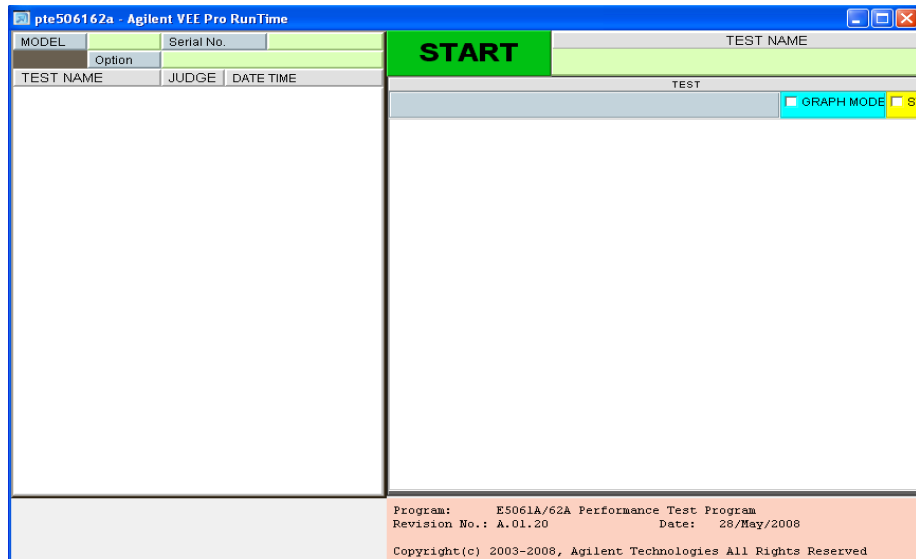

Step 7. The ETE Configuration window appears as shown in Figure 2-3. Input all columns and click on Next.

NOTE: The Home Directory means the directory where pte506162a.vee is stored.

Figure 2-4 ETE Configuration Window

The screenshot shows the 'ETE Configurations' window with a yellow header. It is divided into two main sections: 'Equipment Setting' and 'File Folder setting'.
Equipment Setting:

- Agilent E5061A/62A:** GP-IB Address: 717
- Frequency Counter:** No Use (dropdown), GP-IB Address: 703, Serial Number: [empty], Get Serial Number button
- Dynamic Accuracy Test Kit:** Z5623A (dropdown), GP-IB Address: 712, Serial Number: US01119132, Get Serial Number button
- Power Meter:** E4419B (dropdown), GP-IB Address: 713, Serial Number: GB39510833, Get Serial Number button
- Power Sensor 8482A:** 8482A (dropdown), Serial Number: 2652A13139, Input Serial Number button
- Power Sensor 8483A:** No Use (dropdown), Serial Number: 123, Input Serial Number button
- 85032F/85036B Calibration Kit:** Serial Number: [empty]

File Folder setting:

- Home Directory:** c:\pte506162a

Navigation Buttons: Next, Reset To Default, and Quit.

NOTE:

- 1 The user is required to fill up all this information for the first time of loading the program. The information will be kept in the program.
2. To control the ETE in the performance test program, the talker/listener GPIB address must be set.
3. User must set the GPIB address for each ETE in the ETE Configuration window as same as the GPIB address set in each equipment.
4. To check the GPIB address of the equipment, user can check it through Agilent Connection Expert or equipment itself.
5. If the GPIB address set in the ETE Configuration window it's not same as the GPIB address set in the equipment, an error will occurs because the program cannot talk with the equipment

Step 8. The environment window appears as shown in Figure 2-4. Input the E5061A/E5062A serial number, option and the test conditions. Click on NEXT STEP, when you complete the settings.

Operation
How to perform the E5071C Performance Test Program

Figure 2-5 Environment Information Window

The screenshot shows a software window titled "E5061A/62A Info and Test Conditions". It contains several sections:

- E5061A/62A Info and Test Conditions:** A dropdown menu for "MODEL" is set to "E5062A".
- E5061A/62A Serial Number and Option:** A text field for "Serial No" contains "MY44100917". Below it, "Options" are listed with checkboxes: 100 (checked), 016 (checked), 1E1 (unchecked), 760 (unchecked), and 761 (unchecked). Navigation arrows are present for the first four options.
- Test Conditions:** A section with a blue header containing input fields for "Tested By" (Azlin), "Customer Name" (Agilent), "Date" (28/May/2008 with a "Calendar" button), "Temperature" (23 DEG C), "Humidity" (50 %), "Report Number" (1), and "Comment" (empty). A yellow note below reads "Note: Enter all items except 'Comment'".
- Buttons:** "AUTO READ" (green), "NEXT STEP" (blue), and "QUIT PROGRAM" (pink).

Step 9. The main menu appears as shown in Figure 2-6. For example, click **[F1]All Tests**, if you want to perform all performance tests.

Figure 2-6 Main Window

The screenshot shows a "Select Test Mode:" menu with the following options:

- [F1]All Tests (blue button)
- [F2]Partial Test (purple button)
- [F3]Spot Test (light blue button)
- [F8] Print Test Record (light green button)
- [F9] Input Serial No. (pink button)
- [F12]Program END (yellow button with a dotted border)

The main menu consists of the following.

- “All Tests” executes all performance tests according to the option that the E5061A/E5062A has. All tests starts after clicking on this button
- “Partial Test” executes some of the consecutive tests in the performance tests. The window as Figure 2-7 appears. Choose the first test and the last test you want to perform.

Figure 2-7 Partial Test Window

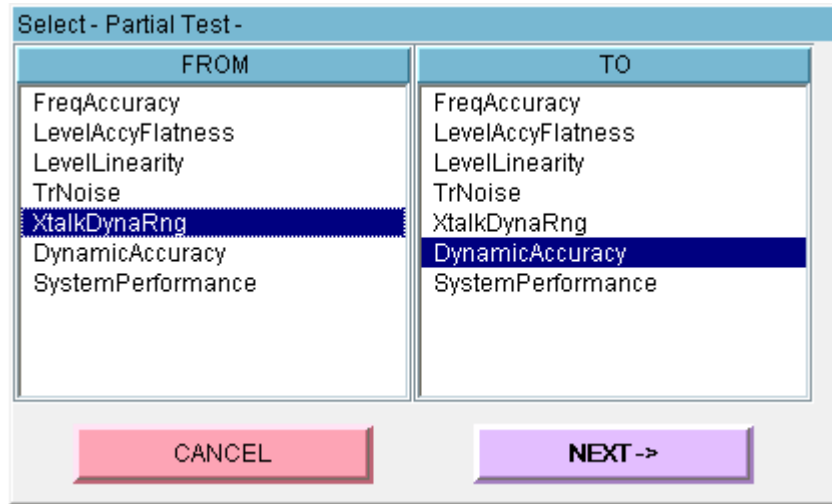

- “Spot Test” executes a performance test. The window as Figure 2-8 appears. Choose a test to execute.

Figure 2-8 Spot Test Window

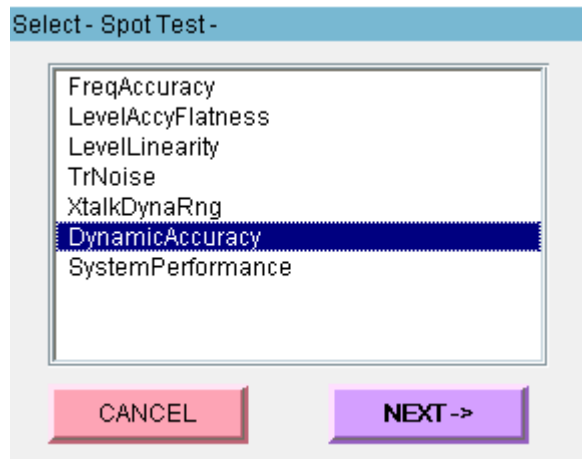

Operation

How to perform the E5071C Performance Test Program

- “Print Test Record” prints out the test record.

You can confirm the past logs of all test records in the following directories. The folder below is on File Folder setting of the ETE configuration. The default folder is C:\pte506162a.

folder\result\TEST_RECORD (log of the test record)

folder\result\TEST_RECORD_HISTORY (log of the test record with ETE information)

- “Input Serial No.” shows the window as Figure 2-4 to set the E5061A/E5062A serial number and the test environment again.
- “Program End” finishes the performance test program.

Main Window Information

Figure 2-9 shows the displayed information

Figure 2-9 Displayed Information in Main Window

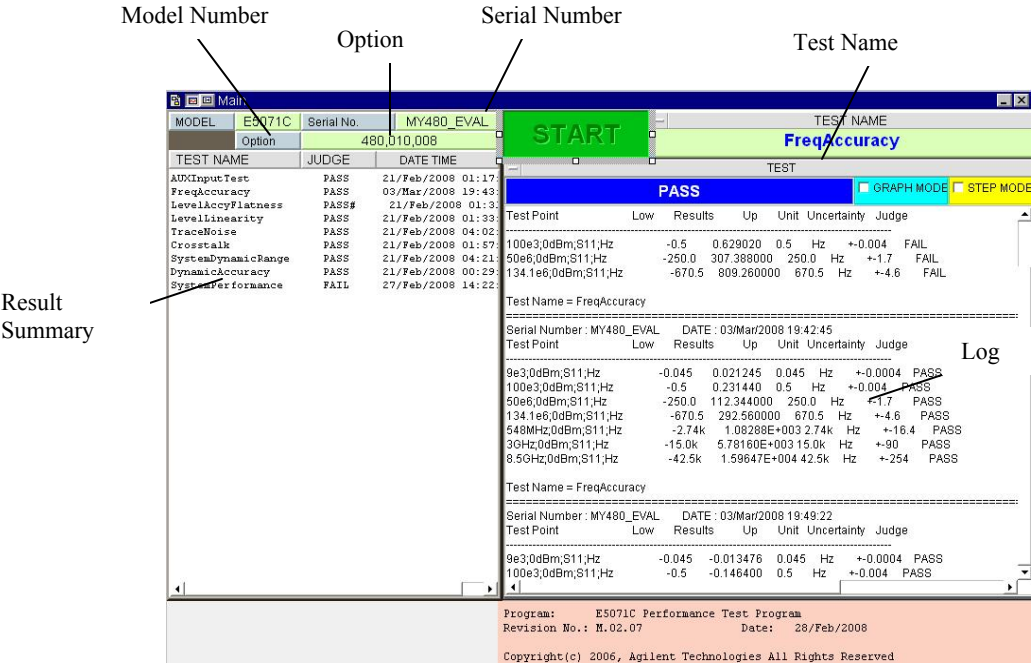

Model Number

The model number of the equipment to be tested.

Serial Number

The serial number of the equipment to be tested.

Option

The installed option in the equipment to be tested.

Test Name

The test executed now.

Operation
Main Window Information

Test Result Summary

This area shows the summary of the test results. The information displayed in each column

Table 2-1 **Column in Test Result Summary**

| Column | Description |
|---------------|--|
| TEST NAME | Name of Test |
| JUDGE | Result of Test. PASS means “pass.” FAIL means “fail.” - means “not performed.” |
| DATE TIME | Time when Test is finished. |

The installed option in the equipment to be tested.

Test Name

The test executed now.