

INSTRUCTION MANUAL
MODEL 9200A
RF MILLIVOLTMETER

BOONTON
ELECTRONICS CORPORATION

791 ROUTE 10, RANDOLPH, NJ 07869
TELEPHONE: 201 — 584-1077 TWX: 710-986-8215

WARRANTY

Boonton Electronics Corporation warrants its products to the original Purchaser to be free from defects in material and workmanship and to operate within applicable specifications for a period of one year from date of shipment, provided they are used under normal operating conditions. This warranty does not apply to active devices that have given normal service, to sealed assemblies which have been opened, or to any item which has been repaired or altered without our authorization.

We will repair or, at our option, replace at no charge any of our products which are found to be defective under the terms of this warranty. Except for such repair or replacement, we will not be liable for any incidental damages or for any consequential damages, as those terms are defined in Section 2-715 of the Uniform Commercial Code, in connection with products covered by this warranty.

BOONTON
ELECTRONICS CORPORATION

791 ROUTE 10, RANDOLPH, NJ 07869
TELEPHONE: 201 — 584-1077 TWX: 710-986-8215

A D D E N D U M

IN-WARRANTY TRANSPORTATION COSTS

When equipment is returned to the factory under our 1 year warranty, surface transportation costs are covered as follows:

1. First 3 Months

To Boonton Electronics - Paid by Boonton

To Customer - Paid by Boonton

2. Subsequent 9 Months

To Boonton Electronics - Paid by Customer

To Customer - Paid by Boonton

N O T E

SHIPPING & PACKAGING INSTRUCTIONS. To avoid the delays and expense of shipping damage, call our Repair Department in advance for instruction on the best way to pack and ship the equipment.

ADDENDUM

Probe and Attachments

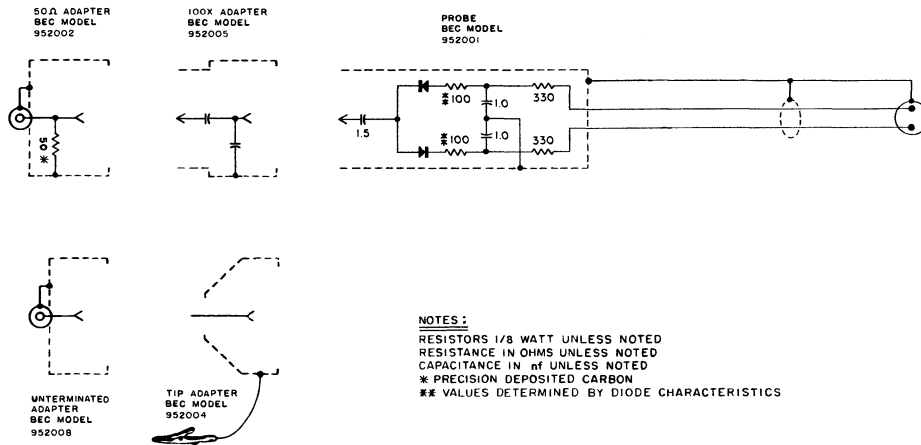

NOTES:
 RESISTORS 1/8 WATT UNLESS NOTED
 RESISTANCE IN OHMS UNLESS NOTED
 CAPACITANCE IN pf UNLESS NOTED
 * PRECISION DEPOSITED CARBON
 ** VALUES DETERMINED BY DIODE CHARACTERISTICS

TABLE OF CONTENTS

SECTION I - INTRODUCTION

Paragraph		Page
1-1	Scope of Manual	1-1
1-3	Purpose of Equipment	1-1
1-5	Description of Equipment	1-1
1-7	Accessories	1-2
1-10	Options	1-5
1-14	Specifications	1-5
1-16	Outline Dimensions	1-5

SECTION II - OPERATION

Paragraph		Page
2-1	General	2-1
2-3	Installation	2-1
2-4	Unpacking	2-1
2-5	Mounting	2-1
2-6	Power Requirements	2-1
2-7	Cable Connections	2-1
2-8	Operating Controls, Indicators, and Connectors	2-1
2-10	Power Application	2-1
2-12	Preliminary Check of Instrument	2-3
2-14	Operating Procedures	2-6
2-15	Programming Measurement Parameters	2-6
2-16	Zeroing the Instrument	2-8
2-17	Making Measurements	2-9
2-18	Application Notes	2-9
2-19	Overload Limits	2-9
2-20	Connection Recommendations	2-9
2-21	Low-Level Measurements	2-9
2-22	Temperature Effects	2-9
2-23	Hum, Noise, and Spurious Pickup	2-9
2-24	Recorder Output	2-9
2-25	Correction Curve for Model 952003 50 Ohm N Tee Adapter	2-9
2-26	Correction Curve for Model 952007 75 Ohm N Tee Adapter	2-9
2-27	Minimum Performance Standards	2-10
2-28	Test Equipment Required	2-10
2-29	Preliminary Setup	2-10
2-30	Automatic Zero Function Test	2-11
2-31	Autoranging Mode Test	2-11
2-32	Range Hold Function Test	2-11
2-33	Basic Instrument Accuracy Test	2-11
2-34	dB Mode Check	2-12
2-35	dB Reference Level Function Test	2-12
2-36	dB Limit Test	2-12

SECTION III — THEORY OF OPERATION

Paragraph		Page
3-1	General	3-1
3-4	Overall Block Diagram	3-1
3-5	Probe	3-1
3-6	Input Module	3-1

SECTION III - THEORY OF OPERATION (cont.)

Paragraph		Page
3-7	Control Module	3-1
3-8	Display Module	3-1
3-9	Power Supply Module	3-1
3-10	Optional Modules	3-1
3-11	Detailed Theory of Operation, Probe Circuits	3-2
3-15	Detailed Theory of Operation, Input P.C. Board Circuits	3-3
3-25	Detailed Theory of Operation, Control P.C. Board Circuits	3-4
3-33	Detailed Theory of Operation, Display P.C. Board Circuits	3-9
3-40	Detailed Theory of Operation, Power Supply Circuits	3-10

SECTION IV - MAINTENANCE

Paragraph		Page
4-1	General	4-1
4-3	Test Equipment Required	4-1
4-5	Troubleshooting Concept	4-1
4-7	Signature Analysis	4-1
4-13	Trouble Localization	4-2
4-14	Gaining Access to Internal Components	4-2
4-15	Visual Inspection	4-2
4-16	Use of Block Diagrams	4-2
4-17	Systematic Troubleshooting	4-2
4-18	Signature Analysis Free-Running Test Procedures	4-5
4-20	Signature Analysis Programmed Test Procedures	4-10
4-22	Non-Volatile RAM Circuit Tests	4-17
4-23	Non-Volatile RAM Test	4-17
4-24	Non-Volatile RAM Battery Test	4-17
4-25	Non-Volatile RAM Battery Replacement	4-18
4-26	Non-Volatile Memory Data	4-18
4-27	General	4-18
4-28	Instrument Gain Data	4-18
4-29	Probe Data	4-19
4-30	Instrument Operation-Related Data	4-19
4-31	Recall and Entry of Instrument Gain Data	4-19
4-33	Recall and Entry of Probe Data	4-20
4-35	Instrument Adjustment and Calibration	4-21
4-36	General	4-21
4-37	Power Supply Adjustments	4-21
4-38	Input Module Calibration and Adjustments	4-21
4-39	DC Calibration	4-22
4-40	AC Calibration	4-22
4-41	DC Recorder Calibration	4-24
4-42	Probe SWR and Frequency Response Tests	4-24
4-43	General	4-24
4-44	SWR Test	4-25
4-45	Frequency Response Tests	4-25
4-46	Alternate Frequency Response and SWR Test Procedure	4-26

SECTION V - PARTS LIST

Paragraph		Page
	Table of Replaceable Parts	5-1

SECTION VI - SCHEMATIC DIAGRAMS

Paragraph	Page
Schematic Diagrams	6-1

APPENDIX A - IEEE-488 BUS INTERFACE OPTION 9200A-01A

Paragraph	Page
A-1 Description	A-1
A-4 Capability	A-1
A-6 Installation	A-1
A-8 Operation	A-1
A-9 Address Assignment	A-2
A-10 Message Terminator	A-2
A-11 Command Response	A-2
A-12 Operating States	A-2
A-13 Remote Programming	A-3
A-14 Bus Programming Syntax	A-3
A-19 Store/Recall Functions Syntax	A-4
A-21 Output Data Format	A-4
A-22 Hold Measurement Function Syntax	A-5
A-23 SRQ Function Syntax	A-5
A-24 Measurement Trigger Syntax	A-5
A-25 Typical Application	A-5
A-27 Use of Hold Measurement, Pull SRQ and Trigger Commands	A-6
A-28 Theory of Operation	A-6
A-29 General	A-6
A-30 Detailed Description (see Figure A-1)	A-6
A-35 Maintenance	A-8
A-36 General	A-8
A-37 Physical Inspection	A-8
A-38 Voltage Checks	A-8
A-39 Active-Device Substitution	A-8
A-40 Signature Analysis	A-8
A-41 Other Analyses	A-8

APPENDIX B - INPUT CHANNEL 2 OPTION 9200A-03

Paragraph	Page
B-1 Description	B-1
B-3 Installation	B-1
B-5 Operation	B-1
B-9 Maintenance	B-2

APPENDIX C - REAR INPUT OPTION 9200A-04

Paragraph	Page
C-1 Description	C-1
C-3 Operation	C-1

LIST OF ILLUSTRATIONS

Figure	Page
1-1 Model 9200A RF Millivoltmeter	vi
1-2 Input Resistance vs. Frequency Curves for Model 952001 Probe	1-3
1-3 Input Capacitance vs. Input Level Curve for Model 952001 Probe	1-3
1-4 Correction Curves for Models 952003 and 952007 Type N Tee Adapters	1-6
1-5 Outline Dimensions	1-12
2-1 Front View of Instrument	2-4
2-2 Rear View of Instrument	2-5

LIST OF ILLUSTRATIONS (Cont.)

Figure		Page
2-3	Attachment of Model 952003 50-Ohm N Tee Adapter to Model 952001 Probe and Model 952014 50-Ohm Termination	2-10
3-1	Overall Block Diagram	3-2
3-2	Input P.C. Board, Detailed Block Diagram	3-5
3-3	Control P.C. Board, Detailed Block Diagram	3-7
3-4	Display P.C. Board, Detailed Block Diagram	3-11
3-5	Power Supply P.C. Board, Detailed Block Diagram	3-13
4-1	Location of Major Assemblies (Sheet 1 of 2)	4-3
4-1	Location of Major Assemblies (Sheet 2 of 2)	4-4
4-2	Input P.C. Board, Voltage and Waveform Data	4-6
4-3	Control P.C. Board Bit Switch Settings	4-7
4-4	Non-Volatile RAM Battery Test and Connection Points	4-19
4-5	RF Probe Frequency Response Test Setup	4-25
4-6	Swept Frequency Response Test Setup	4-26
6-1	Main Frame A1, Schematic Diagram	6-3
6-2	Display Board A2, Schematic Diagram	6-5
6-3	Chopper Board A4, Schematic Diagram	6-7
6-4	Control Board A5, Schematic Diagram (Sheet 1 of 2)	6-9
6-4	Control Board A5, Schematic Diagram (Sheet 2 of 2)	6-11
6-5	Input Module Board A6, Schematic Diagram (Sheet 1 of 2)	6-13
6-5	Input Module Board A6, Schematic Diagram (Sheet 2 of 2)	6-15
6-6	Power Supply Board A7, Schematic Diagram	6-17
6-7	Options, Schematic Diagram	6-19
A-1	IEEE 488 Bus Interface Option, Block Diagram	A-7
A-2	Interface Board A23, Schematic Diagram	A-9

LIST OF TABLES

Table		Page
1-1	Optional Accessories	1-4
1-2	Accessory Requirements	1-5
1-3	Performance Specifications	1-7
2-1	Operating Controls, Indicators, and Connectors	2-2
2-2	Examples of Channel 3 Measurements	2-8
4-1	Test Equipment List	4-1
4-2	Control Board Address Field Test	4-8
4-3	Control Board Memory Decoding Test	4-8
4-4	Control Board I/O Decoding Test	4-9
4-5	Control Board ROM 0 Test (30602)	4-9
4-6	Control Board ROM 1 Test (31502)	4-9
4-7	Interface Board ROM 2 Test (31202)	4-10
4-8	Control Board 4ABIO Test	4-11
4-9	Control Board 4CIO Test	4-11
4-10	Control Board 4DIO Test	4-11
4-11	Display Visual Test	4-12
4-12	Control Board Display Test (ROM 950 004)	4-12
4-13	Control Board Display Scan Test	4-12
4-14	Keyboard Visual Test	4-13
4-15	Control Board RAM Test	4-13
4-16	Input Module Channel 1 OAIO Test	4-14
4-17	Input Module Channel 1 OBIO Test	4-14

LIST OF TABLES (cont.)

Table		Page
4-18	Input Module Channel 1 OCIO Test	4-15
4-19	Input Module Channel 1 ODIO Test	4-15
4-20	Input Module Channel 2 IAIO Test	4-15
4-21	Input Module Channel 2 IBIO Test	4-16
4-22	Input Module Channel 2 ICIO Test	4-16
4-23	Input Module Channel 2 IDIO Test	4-17
A-1	Address Assignment	A-2
	Replaceable Parts List	A-8

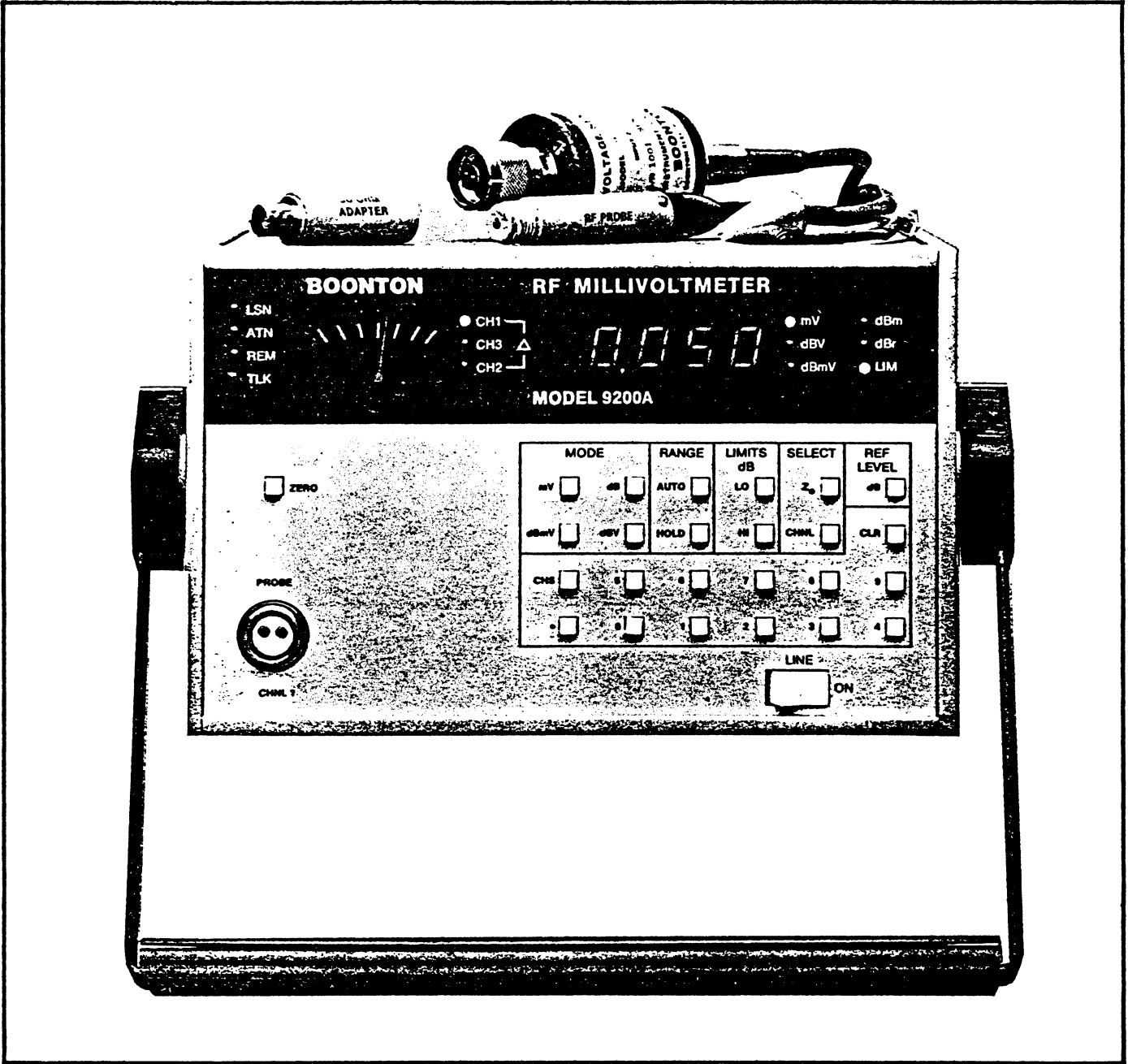

Figure 1-1 Model 9200A RF Millivoltmeter

SECTION I

INTRODUCTION

1-1. SCOPE OF MANUAL.

1-2. This instruction manual provides descriptive data, operating instructions, theory of operation, maintenance instructions, and a parts list for the Model 9200A RF Millivoltmeter. (See Figure 1-1.) The instrument is manufactured by Boonton Electronics Corporation, Randolph, New Jersey.

1-3. PURPOSE OF EQUIPMENT.

1-4. The instrument is microprocessor-based with unique features that make it useful for systems requirements as well as for manual operation. The basic instrument can measure RF voltage levels from 200 microvolts to 3 volts over a frequency range from 10 kHz to 1.2 GHz. An optional Model 952005 100:1 Voltage Divider extends the voltage range to 300 V up to 700 MHz. A 50-ohm terminated RF sensor, Model 952009, is also available to measure RF voltage levels from 200 microvolts to 3 volts over a frequency range from 100 kHz to 2.5 GHz. Option 9200A-03 adds a second complete input section that allows the connection of an additional RF probe for simultaneous measurements of two voltage levels.

Measured RF levels can be displayed directly in mV, dBV, dBmV, dB relative to an arbitrary reference, or dBm (dB relative to 1 mW across any impedance between 50 ohms and 600 ohms). Typical uses of the instrument include:

- a. Measurement of transistor parameters.
- b. SWR and return loss measurements with directional couplers, reflection coefficient bridges, and slotted lines.
- c. Gain and loss measurements of wide-band amplifiers.
- d. Adjustment of tuned circuits in narrow-band amplifiers.
- e. Adjustment, performance measurements, and parameter evaluation of RF filters.
- f. Measurement of SWR, return loss, and attenuation of RF attenuators.
- g. Measurement of output levels of signal generators, adjustment of baluns, harmonic distortion measurements of RF signals, and adjustment of RF circuits for minimum voltage (null) or maximum voltage (peak).

1-5. DESCRIPTION OF EQUIPMENT.

1-6. The instrument is packaged as a compact bench unit with optional adjustable-angle bail. Hardware kits to accommodate either one or two instruments for rack mounting are also available as options. The basic characteristics of the instrument include high reliability, fast warmup, long

intervals between calibration, good serviceability, and light weight. Incorporation of a microprocessor, together with a stored-program memory and a non-volatile memory, result in performance features and operating convenience not previously available in a general-purpose RF millivoltmeter. Among the outstanding performance features are:

a. **Wide Frequency Range.** The calibrated frequency range of the instrument is determined by the probe used with the instrument. The Model 952001 RF Probe supplied with the instrument provides calibrated indications from 10 kHz to 1.2 GHz, with uncalibrated response to beyond 8 GHz. An optional Model 952009 RF Sensor provides calibrated, 50-ohm terminated indications from 100 kHz to 2.5 GHz.

NOTE

Sensitivity and range linearization data for the probe supplied with the instrument is stored in non-volatile memory. If another probe is used with the instrument, data for this probe must be entered into non-volatile memory before using the probe. Data entry is a simple procedure, requiring only operation of an internal switch and entry of data through the front-panel keys. No further calibration is necessary.

b. **Wide Measurement Range.** The instrument has eight voltage measurement ranges from 1 mV to 3 volts full scale, arranged in a 1-3-10 sequence. In the dB measurement modes, it covers a range of 80 dB in 8 ranges, with 0.01 dB resolution. The measurement capability of the instrument can be extended to 300 volts at frequencies up to 700 MHz through use of the optional Model 952005 100:1 Voltage Divider.

c. **True RMS Response.** Waveform response of the instrument probe is true RMS for inputs below 30 mV, allowing accurate voltage measurements with all types of waveforms. Probe waveform response changes gradually as the input voltage is raised above 30 mV approaching peak-to-peak at the higher levels. The instrument shapes the response digitally to indicate RMS voltage, provided that the input is reasonably sinusoidal, as with CW or FM input signals.

d. **Low Noise.** The instrument has been designed and constructed to minimize noise from all sources. The probe cable is of a special low-noise design; vigorous flexing causes only momentary, minor deflections on the most sensitive range of the instrument. The probes are insensitive to shock and vibration; even sharp tapping on the probe barrel causes no visible deflection on any range. Internal signal amplification occurs at approximately 94

Section I Introduction

Hz, thereby reducing susceptibility to 50 or 60 Hz fields. A low-noise solid-state chopper is used.

e. **Key Selection of Measurement Modes.** A choice of measurement modes is available to the operator. Measurements in terms of mV, dBV, dBmV, dB relative to an arbitrarily chosen reference, or dBm (dB relative to 1 mW across any impedance between 50 and 600 ohms) can be selected by merely pressing the appropriate front-panel key. The keyboard also allows entry of dB reference levels and impedance values for these measurement modes.

f. **Display.** Measured values are displayed on a 4-digit, LED type readout with decimal points and minus sign. Annunciators associated with the display indicate the units of measurement. The result is a clear, direct, unambiguous readout that minimizes the possibility of misinterpretation. The display is also used to show data being entered into non-volatile memory and to display data recalled from non-volatile memory.

g. **Analog Indications.** A front-panel meter provides relative RF level indications for peaking or nulling applications. A rear-panel dc output supplies 10 volts full scale that is linear with voltage in the mV mode, or linear in dB over the entire 80 dB range in any of the dB modes.

h. **Automatic Ranging.** Autoranging under control of the microprocessor eliminates the need for manual ranging by the operator. Alternately, a measurement range can be retained for measurements, if desired, by selecting a range hold mode. Application of input levels beyond the measurement capability of the instrument in the autorange mode or outside the selected range in the range hold mode results in an error indication on the display.

i. **Automatic Zeroing.** An automatic zeroing circuit eliminates the need for tedious, often inaccurate manual zeroing. With zero input to the probe, pressing the front-panel ZERO key causes the microprocessor to compute and store zero corrections for each range, which are applied to subsequent readings. A logic transition is available at a rear-panel connector for automatic turn-off of a source during the automatic zeroing sequence.

j. **Stored Probe Data.** Sensitivity and range linearization data for two probes may be stored in the instrument non-volatile memory. Probe data is written into memory at the factory for probes ordered with the instrument; probe data may also be written into memory quickly and easily in the field. A hard copy of stored data is provided under the right side cover of the instrument. The microprocessor corrects measurements automatically in accordance with the stored probe data.

k. **High/Low dB Limits.** High and low dB limits can be entered through the instrument keyboard. A panel annun-

ciator indicates when either limit has been exceeded, whether the instrument is operating in the mV or any dB mode. Rear-panel TTL outputs also provide remote indications of out-of-limit conditions.

l. **Solid-state Chopper.** Signal amplification in the instrument occurs at approximately 94 Hz. Input signals from the probe are converted into 94 Hz signals by a solid-state, low-level input modulator (chopper), which represents a distinct improvement over electromechanical choppers. Extended service life is assured through the elimination of contact wear, contamination, and other problems associated with electromechanical choppers.

m. **Maintenance.** The instrument is designed for easy maintenance. Accessibility to all printed circuit boards is excellent, all interconnecting cables are plug-in, and all active devices are socket-mounted. Connection facilities for signature analysis are incorporated, and special diagnostic ROMs are available. Digital circuit troubles can be localized rapidly and accurately using the signature-analysis maintenance technique, thereby reducing instrument downtime.

1-7. ACCESSORIES.

1-8. The instrument is supplied complete with power cord and the following standard accessories:

a. **Model 952001 RF Probe.** This probe is used for calibrated RF measurements over a frequency range of 10 kHz to 1.2 GHz, and for uncalibrated relative measurements to 8 GHz and beyond. It is overload protected to 10 volts ac and 400 volts dc. See Figures 1-2 and 1-3 for input resistance and capacitance.

b. **Model 952004 Probe Tip.** This probe tip can be used with the Model 952001 for RF measurements to frequencies of approximately 100 MHz. It has an integral grounding clip lead.

c. **Model 952002 50-Ohm BNC Adapter.** This female adapter adapts the instrument probe for measurements in a 50-ohm system at frequencies up to 1.2 GHz.

1-9. A variety of optional accessories is available for added versatility. Table 1-1 lists these optional accessories and their uses and characteristics.

NOTE

To fully realize the capabilities of the instrument, the accessories listed in Table 1-2 are required for the listed ranges of operation.

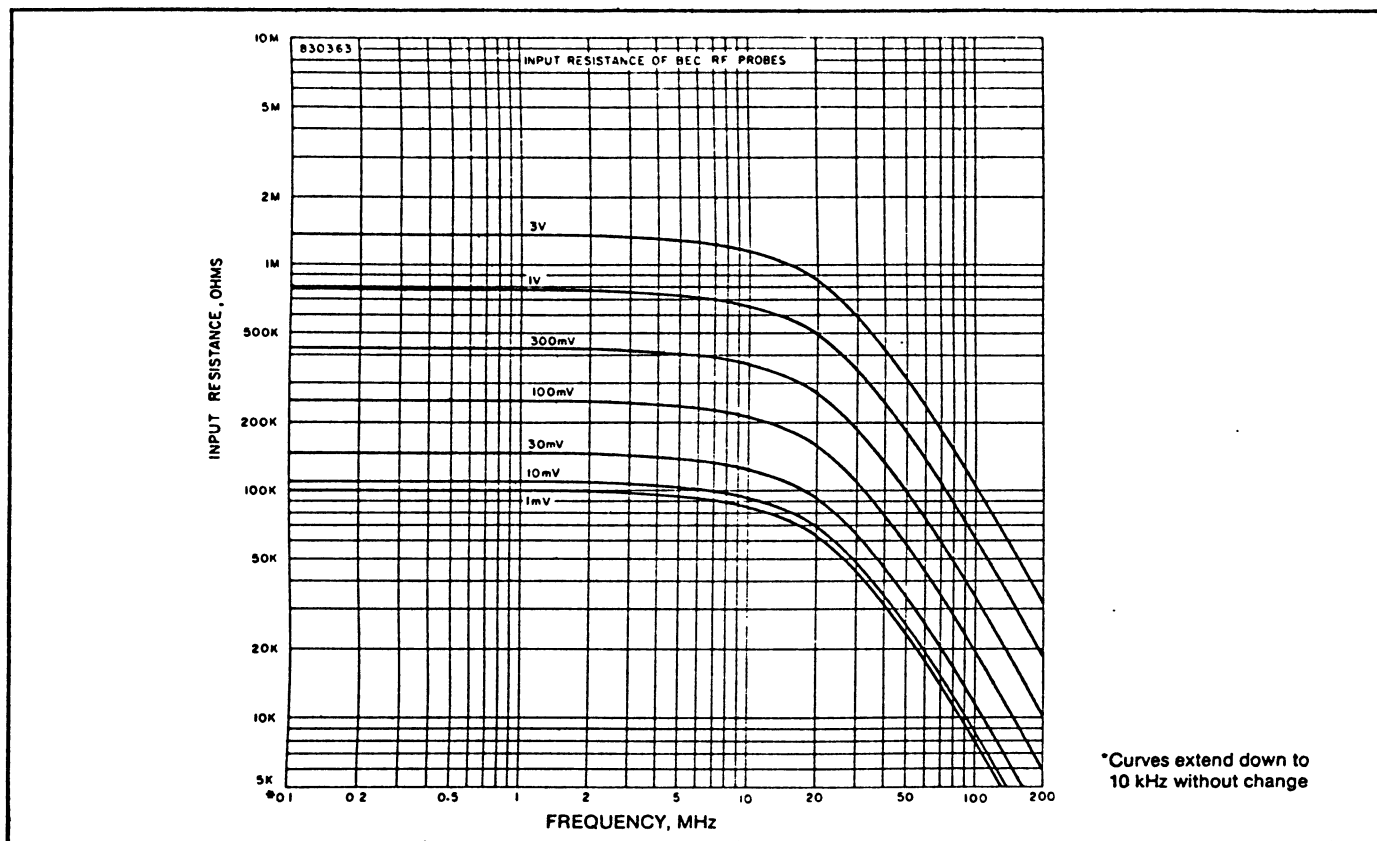

Figure 1-2 Input Resistance vs Frequency Curves for Model 952001 Probe at Various Input Levels

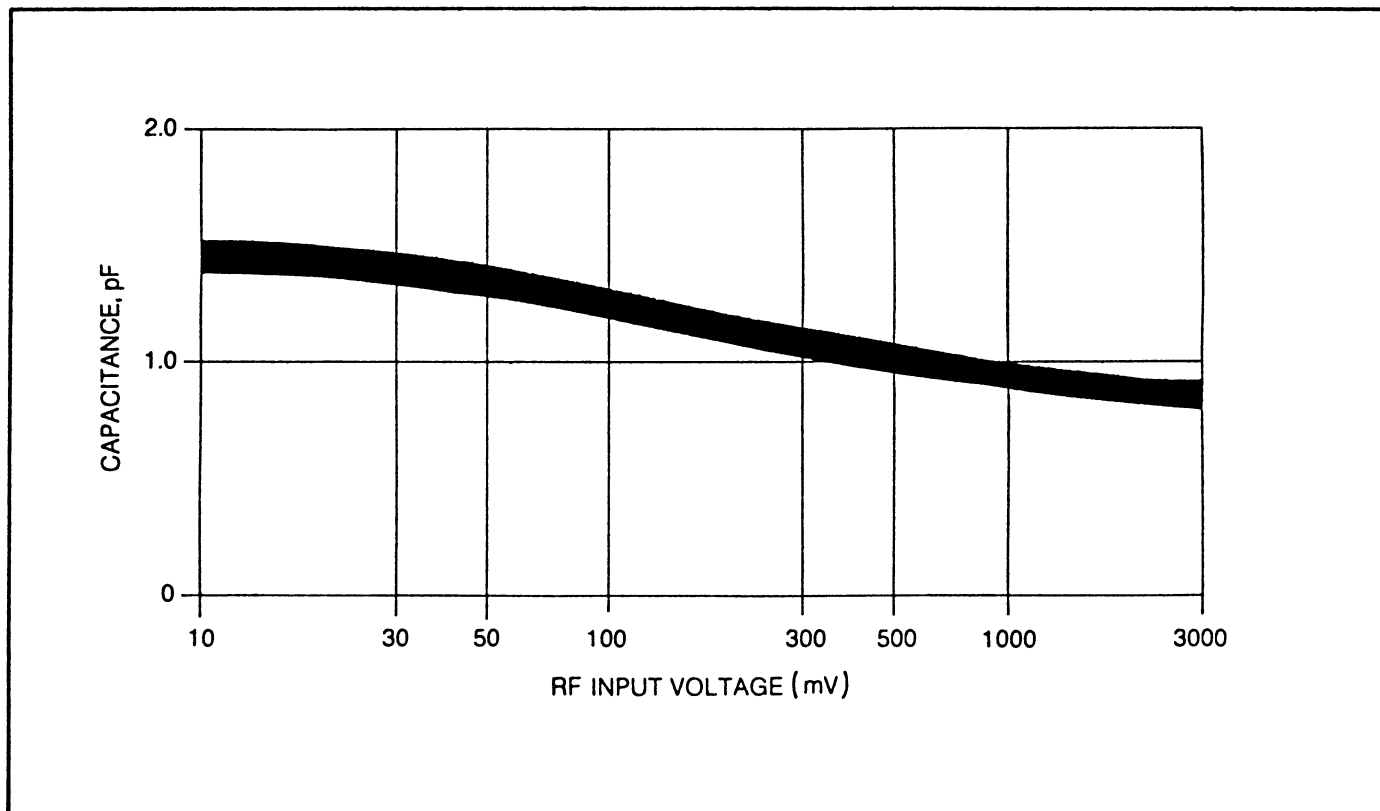

Figure 1-3 Input Capacitance vs Input Level Curve for Model 952001 Probe

TABLE 1-1. OPTIONAL ACCESSORIES

Accessory	Use and Characteristics	Accessory	Use and Characteristics
Model 952008 Unterminated BNC Adapter	Female adapter for use with 952001 probe; adapts probe for coaxial connection at frequencies up to 100 MHz, or to 400 MHz when fed from a low-impedance source in an electrically-short system	Model 952007 75-Ohm N Tee Adapter	Same as Model 952003, except for use in 75-ohm line, 10 kHz to 1.0 GHz; see Figure 1-4 for correction of output level at high frequency
Model 952005 100:1 Voltage Divider	For use with 952001 probe; attenuates input signal by a factor of 100 (adds $\pm(1 + f_{\text{MHz}}/200)\%$ to instrument inaccuracy); allows measurements to 300 volts, RMS measurements to 3 volts; 50 kHz to 700 MHz frequency range; maximum input of 1000 volts, dc plus ac	Model 952014 50-Ohm N Termination	50-ohm termination for Model 952003.
Model 952006 75-Ohm BNC Adapter	Female adapter for use with 952001 probe; adapts probe for measurements in 75-ohm systems up to 500 MHz; fitted with 50 Ω BNC connector.	Model 952015 75-Ohm N Termination	75-ohm termination for Model 952007
Model 952003 50-Ohm N Tee Adapter	Permits connection of Model 952001 RF Probe into 50-ohm line; frequency range, 10 kHz to 1.2 GHz; input and output connectors both female; see Figure 1-4 for correction of output level at high frequencies	Model 952013 Storage Container	Storage case for RF millivoltmeter accessories
		Model 952011 50-Ohm Accessory Kit	Consists of Models 952003, 952005, 952008 and 952014 in Model 952013 Storage Container
		Model 952012 75-Ohm Accessory Kit	Consists of Models 952005, 952007, 952008 and 952015 in Model 952013 Storage Container
		P/N 950000	Rack mounts one Model 9200A, placed either right or left on 19-inch spacing
		P/N 950001	Rack mounts two Model 9200A instruments side-by-side
		P/N 950002	Mounts one Model 9200A with older half-rack units, left or right
		P/N 950029	Transit case
		P/N 952000	Calibration data cartridge for automatic calibration using HP 9825 controller (see Section IV).

1-10. OPTIONS.

1-11. Several standard options are currently available. These options are:

Number	Description
9200A-01A	IEEE 488 Bus Interface - Duplicates all front panel functions except on/off power switch; outputs all range data and status information
9200A-03	Second Channel Input - Two separate measurement channels; allows display of channel 1, channel 2, or channel 3 (channel 1 minus channel 2, expressed in dB)
9200A-04	Rear Input - Duplicates front panel channel 1 input probe connector

NOTE

For descriptions of these options and instructions for field installation and use, refer to the appendices to this manual.

1-12. Option 9200A-03 is especially useful. With this option, the instrument can be fitted with two probes and can be programmed through front panel keys to display the input to either probe or the difference between the two input levels, in dB. This option simplifies the measurement of insertion loss or gain; the gain or loss is displayed directly with no need to monitor and control leveling of the signal source, other than to control the source impedance and prevent input overload.

1-13. Inquiries regarding special applications of the instrument to specific customer requirements are invited. Direct

TABLE 1-2. ACCESSORY REQUIREMENTS

Measurement Range	Required Accessories
10 kHz to 1.2 GHz	Model 952002 50-ohm BNC Adapter for shielded connection to 50-ohm line; Model 952006 for 75-ohm line (to 500 MHz). Model 952003 50-ohm Tee Adapter for connection into 50-ohm line; Model 952007 for 75-ohm line (to 1.0 GHz).
Above 1.2 GHz	Model 952009 50-ohm terminated sensor (100 kHz-2.5 GHz).
Input levels to 300 volts, or RMS response to 3 V	Model 952005 100:1 Voltage Divider (50 kHz to 700 MHz); use with Model 952001 RF Probe only.

such inquiries to the Applications Engineering Department of Boonton Electronics Corporation.

1-14. SPECIFICATIONS.

1-15. Pertinent performance specifications of the instrument are listed in Table 1-3.

1-16. OUTLINE DIMENSIONS.

1-17. Outline dimensions of the instrument are shown in Figure 1-5.

CORRECTION FOR INSERTION LOSS

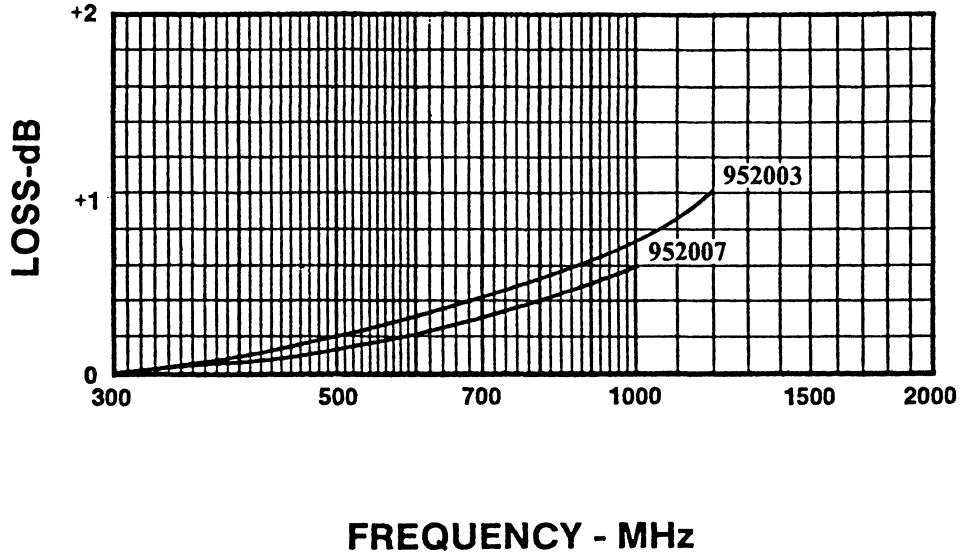

NOTE

Attenuation shown is between the input and output ports of the tee. The instrument measures the input voltage of the tee.

Subtract the correction from the value indicated on the instrument if the output voltage of the tee is to be measured.

Do not use the correction if terminated measurements are required (Model 91-15A termination installed on the output port).

Figure 1-4 Correction Curves for Models 952003 and 952007 Type N Tee Adapters

TABLE 1-3. PERFORMANCE SPECIFICATIONS

Parameter	Specifications																												
VOLTAGE RANGE	200 μ V to 3V in 8 ranges (300 V to 700 MHz with Divider). Indications down to 50 μ V																												
VOLTAGE DISPLAY	1.000, 3.000, 10.00, 30.00, 100.0, 300.0, 1000, and 3000 mV fs																												
dB RANGE	80 dB in 8 ranges, 0.01 dB resolution																												
dB DISPLAY: Units	dBmV (0 dB equivalent to 1 mV), dBV (0 dB equivalent to 1V), dBm (0 dB equivalent to voltage drop generated when 1 mW is dissipated in selectable Z_o reference), or dB _r (0 dB equivalent to any desired dB reference level)																												
Z_o Impedance	Any value from 50 to 600 ohms																												
Reference dB Offset	Any offset can be keyboard selected to 0.01 dB resolution provided that the available display range of ± 99.99 dB is not exceeded																												
RANGING	Autorangeing, plus hold-on-range. Individual ranges may be commanded via bus interface option																												
FREQUENCY RANGE	10 kHz to 1.2 GHz, Model 952001 Probe; 100 kHz to 2.5 GHz, optional Model 952009 Sensor																												
WAVEFORM RESPONSE	RMS to 30 mV, calibrated in rms of a sinewave above 30 mV (RMS to 3V and 700 MHz with Divider)																												
CREST FACTOR (C.F.)	<table border="1"> <thead> <tr> <th colspan="2">Direct Input</th> <th colspan="2">With Divider</th> </tr> <tr> <th>Level</th> <th>C.F.</th> <th>Level</th> <th>C.F.</th> </tr> </thead> <tbody> <tr> <td>300 μV</td> <td>140</td> <td>30 mV</td> <td>140</td> </tr> <tr> <td>1 mV</td> <td>42</td> <td>100 mV</td> <td>42</td> </tr> <tr> <td>3 mV</td> <td>14</td> <td>300 mV</td> <td>14</td> </tr> <tr> <td>10 mV</td> <td>4.2</td> <td>1V</td> <td>4.2</td> </tr> <tr> <td>30 mV</td> <td>1.4</td> <td>3V</td> <td>1.4</td> </tr> </tbody> </table>	Direct Input		With Divider		Level	C.F.	Level	C.F.	300 μ V	140	30 mV	140	1 mV	42	100 mV	42	3 mV	14	300 mV	14	10 mV	4.2	1V	4.2	30 mV	1.4	3V	1.4
Direct Input		With Divider																											
Level	C.F.	Level	C.F.																										
300 μ V	140	30 mV	140																										
1 mV	42	100 mV	42																										
3 mV	14	300 mV	14																										
10 mV	4.2	1V	4.2																										
30 mV	1.4	3V	1.4																										
INPUT:																													
Probe, Model 952001	Button center-conductor, 1/2"-20 threaded ground shell																												
Probe Tip	Needle tip, ground clip lead, Model 952004, supplied																												
Adapter	50 Ω terminated BNC female, Model 952002, supplied																												
Sensor, optional																													
Model 952009	Type N male																												
Optional Accessories	Refer to Table 1-1																												
Impedance	See Figures 1-2 and 1-3																												
Loss	See Figure 1-4																												
Maximum AC Input	10V, all frequencies and ranges																												
Maximum DC Input	400V, all ranges																												
DISPLAY	4-digit LED display of voltage or dB. Auxiliary analog display, uncalibrated, proportional to voltage (voltage mode) or dB (dB modes)																												
RECORDER OUTPUT	10V fs proportional to indicated voltage (voltage mode) over each range; 8V equivalent to 0 dBm regardless of Z_o (dB modes) with a sensitivity of 1V per 10 dB change over the entire range																												

TABLE 1-3. PERFORMANCE SPECIFICATIONS (cont.)

Parameter	Specifications																																										
<p>ACCURACY:</p> <p>A. Basic Uncertainty</p>	<p>The maximum uncertainty is the sum of the uncertainties listed in sections A, B, and C</p> <table border="0"> <thead> <tr> <th>Voltage Level</th> <th>mV</th> <th>dBV, dBmV, dBm</th> </tr> </thead> <tbody> <tr> <td>3 mV - 3000 mV</td> <td>1% rdg ± 1 count</td> <td></td> </tr> <tr> <td>1 mV - 3 mV</td> <td>2% rdg ± 2 counts</td> <td>see curve</td> </tr> <tr> <td>0.2 mV - 1 mV</td> <td>3% rdg ± 3 counts</td> <td></td> </tr> </tbody> </table> <p>Uncertainty vs. Input Level for dBV, dBmV</p> <table border="0"> <thead> <tr> <th>dBmV</th> <th>-10</th> <th>0</th> <th>10</th> <th>20</th> <th>30</th> <th>40</th> <th>50</th> <th>60</th> <th>70</th> </tr> </thead> <tbody> <tr> <td>dBV</td> <td>-70</td> <td>-60</td> <td>-50</td> <td>-40</td> <td>-30</td> <td>-20</td> <td>-10</td> <td>0</td> <td>10</td> </tr> <tr> <td>dBm</td> <td>-57</td> <td>-47</td> <td>-37</td> <td>-27</td> <td>-17</td> <td>-7</td> <td>3</td> <td>13</td> <td>23</td> </tr> </tbody> </table>	Voltage Level	mV	dBV, dBmV, dBm	3 mV - 3000 mV	1% rdg ± 1 count		1 mV - 3 mV	2% rdg ± 2 counts	see curve	0.2 mV - 1 mV	3% rdg ± 3 counts		dBmV	-10	0	10	20	30	40	50	60	70	dBV	-70	-60	-50	-40	-30	-20	-10	0	10	dBm	-57	-47	-37	-27	-17	-7	3	13	23
Voltage Level	mV	dBV, dBmV, dBm																																									
3 mV - 3000 mV	1% rdg ± 1 count																																										
1 mV - 3 mV	2% rdg ± 2 counts	see curve																																									
0.2 mV - 1 mV	3% rdg ± 3 counts																																										
dBmV	-10	0	10	20	30	40	50	60	70																																		
dBV	-70	-60	-50	-40	-30	-20	-10	0	10																																		
dBm	-57	-47	-37	-27	-17	-7	3	13	23																																		
<p>B. Frequency Effect</p>	<p>50 Ω MEASUREMENTS, using Model 952001 Probe with Model 952002 BNC Adapter or terminated Model 952003 N Tee Adapter</p> <table border="0"> <thead> <tr> <th>Frequency</th> <th>mV</th> <th>dBV, dBmV, dBm</th> </tr> </thead> <tbody> <tr> <td>1 MHz (cal. frequency)</td> <td>0</td> <td>0</td> </tr> <tr> <td>10 kHz - 100 MHz</td> <td>1% rdg</td> <td>0.09 dB</td> </tr> <tr> <td>100 MHz - 1 GHz</td> <td>3% rdg</td> <td>0.27 dB</td> </tr> <tr> <td>1 GHz - 1.2 GHz</td> <td>7% rdg</td> <td>0.63 dB</td> </tr> </tbody> </table> <p>SWR: 1.05 to 300 MHz, 1.10 to 1 GHz, 1.15 to 1.2 GHz</p> <p>50 Ω MEASUREMENTS, using Model 952009 Terminated Voltage Sensor</p> <table border="0"> <thead> <tr> <th>Frequency</th> <th>mV</th> <th>dBV, dBmV, dBm</th> </tr> </thead> <tbody> <tr> <td>1 MHz (cal. frequency)</td> <td>0</td> <td>0</td> </tr> <tr> <td>100 kHz - 1 GHz</td> <td>1% rdg</td> <td>0.09 dB</td> </tr> <tr> <td>1 GHz - 2 GHz</td> <td>3% rdg</td> <td>0.27 dB</td> </tr> <tr> <td>2 GHz - 2.5 GHz</td> <td>5% rdg</td> <td>0.45 dB</td> </tr> </tbody> </table> <p>SWR: 1.05 to 2 GHz, 1.10 to 2.5 GHz</p>	Frequency	mV	dBV, dBmV, dBm	1 MHz (cal. frequency)	0	0	10 kHz - 100 MHz	1% rdg	0.09 dB	100 MHz - 1 GHz	3% rdg	0.27 dB	1 GHz - 1.2 GHz	7% rdg	0.63 dB	Frequency	mV	dBV, dBmV, dBm	1 MHz (cal. frequency)	0	0	100 kHz - 1 GHz	1% rdg	0.09 dB	1 GHz - 2 GHz	3% rdg	0.27 dB	2 GHz - 2.5 GHz	5% rdg	0.45 dB												
Frequency	mV	dBV, dBmV, dBm																																									
1 MHz (cal. frequency)	0	0																																									
10 kHz - 100 MHz	1% rdg	0.09 dB																																									
100 MHz - 1 GHz	3% rdg	0.27 dB																																									
1 GHz - 1.2 GHz	7% rdg	0.63 dB																																									
Frequency	mV	dBV, dBmV, dBm																																									
1 MHz (cal. frequency)	0	0																																									
100 kHz - 1 GHz	1% rdg	0.09 dB																																									
1 GHz - 2 GHz	3% rdg	0.27 dB																																									
2 GHz - 2.5 GHz	5% rdg	0.45 dB																																									

TABLE 1-3. PERFORMANCE SPECIFICATIONS (cont.)

Parameter	Specifications				
	75 Ω MEASUREMENTS, using Model 952001 Probe with Model 952006 BNC Adapter				
	Frequency		mV	dBV, dBmV, dBm	
	1 MHz (cal. frequency)		0	0	
	10 kHz - 100 MHz		1% rdg	0.09 dB	
	100 MHz - 300 MHz		3% rdg	0.27 dB	
	300 MHz - 500 MHz		6% rdg	0.54 dB	
	SWR: 1.05 to 150 MHz, 1.10 to 300 MHz, 1.20 to 500 MHz				
	75 Ω MEASUREMENTS, using Model 952001 Probe with terminated Model 952007 N Tee Adapter				
	Frequency		mV	dBV, dBmV, dBm	
	1 MHz (cal. frequency)		0	0	
	10 kHz - 100 MHz		1% rdg	0.09 dB	
	100 MHz - 700 MHz		3% rdg	0.27 dB	
	700 MHz - 1 GHz		7% rdg	0.63 dB	
	SWR: 1.05 to 150 MHz, 1.10 to 750 MHz, 1.25 to 1 GHz				
C. Temperature Effect	Model 952001 Probe or Model 952009 Sensor				
	Temperature	Instrument	mV Probe/Sensor	dBV, dBmV, dBm Instrument Probe Sensor	
	21°C - 25°C	0	0	0	0
	18°C - 30°C	0	1% rdg	0	0.09 dB
	10°C - 40°C	1% rdg	5% rdg	0.09 dB	0.45 dB
	0°C - 55°C	2% rdg	12.5% rdg	0.18 dB	1.16 dB
LINE STABILITY	Less than 0.2% rdg with ±10% line voltage change at reference line conditions of 115 to 120 V, 50 to 400 Hz. Usable after 5 min. warmup				
ZERO	Automatic, operated by panel key switch				
dB LIMITS	Front panel selectable dB limits, range ±99 dB, resolution 0.01 dB. Front panel LIM annunciator indicates out-of-limits condition. Rear panel TTL outputs indicate high or low condition				
ANNUNCIATORS	LEDs indicate mV, dBV, dBmV, dBm, and dB. Also show use of channel 1 (CH1), channel 2 (CH2), or channel 3 (CH3) with option -03 where CH3=CH1-CH2 in dB. Indicate IEEE-488 bus activity (LSN, ATN, REM, and TLK) with option -01				
POWER	100, 120, 220, 240 V ±10%, 50-400 Hz; 24 VA				
WEIGHT	10 lbs (4.54 kg)				
DIMENSIONS	See Figure 1-5				

TABLE 1-3. PERFORMANCE SPECIFICATIONS (cont.)

Parameter	Specifications										
<p>OPTIONS 01A IEEE 488 Bus Interface</p>	<p>Duplicates all front panel functions except on/off power switch. In addition, individual voltage and dB ranges may be selected and selectively zeroed. This interface implements the following subset of the IEEE 488 1978 Standard:</p> <p>SH1 Source handshake, complete capability</p> <p>AH1 Acceptor handshake, complete capability</p> <p>T6 Basic talker, serial poll, unaddress if MLA, no talker only capability</p> <p>TE0 No extended talker capability</p> <p>L4 Basic listener, run address if MTA, no listener only capability</p> <p>LE0 No extended listener capability</p> <p>SR1 Service request capability</p> <p>RL2 Remote-local capability, no local lockout</p> <p>PP0 No parallel poll capability</p> <p>DC0 No device clear capability</p> <p>DT1 Device trigger capability</p> <p>C0 No controller capability</p> <p>Output data and status information follows the following format: <code>abcsdddEsd,S,R (cr)* (lf)*</code></p> <p>ab = mode (MV = voltage in mV; DM = dBmV; DR = dB reference; DV = dBV; DB = dB)</p> <p>c = channel (A = 1; B = 2; C = 3)</p> <p>s = sign (+ or -)</p> <p>ddd = data (four digits, each digit 0 thru 9)</p> <p>Esd = exponent, sign, digit</p> <p>S = status digit</p> <table data-bbox="730 1491 1429 1722"> <tr> <td>0 no error</td> <td>5 zero acquisition out of range — excessive negative offset</td> </tr> <tr> <td>1 entry too small</td> <td>(hardware malfunction)</td> </tr> <tr> <td>2 entry too large</td> <td>6 zero acquisition out of range — excessive positive offset</td> </tr> <tr> <td>3 underrange</td> <td>(input too large)</td> </tr> <tr> <td>4 overrange</td> <td>7 channel 3 over/underrange</td> </tr> </table>	0 no error	5 zero acquisition out of range — excessive negative offset	1 entry too small	(hardware malfunction)	2 entry too large	6 zero acquisition out of range — excessive positive offset	3 underrange	(input too large)	4 overrange	7 channel 3 over/underrange
0 no error	5 zero acquisition out of range — excessive negative offset										
1 entry too small	(hardware malfunction)										
2 entry too large	6 zero acquisition out of range — excessive positive offset										
3 underrange	(input too large)										
4 overrange	7 channel 3 over/underrange										

TABLE 1-3. PERFORMANCE SPECIFICATIONS (cont.)

Parameter	Specifications																
03 Input Channel 2	<p>R = range digit</p> <table data-bbox="747 315 1201 483"> <tr> <td>0</td> <td>1 mV</td> <td>4</td> <td>100 mV</td> </tr> <tr> <td>1</td> <td>3 mV</td> <td>5</td> <td>300 mV</td> </tr> <tr> <td>2</td> <td>10 mV</td> <td>6</td> <td>1000 mV</td> </tr> <tr> <td>3</td> <td>30 mV</td> <td>7</td> <td>3000 mV</td> </tr> </table> <p>*cr = carriage return (user selected terminator) *lf = line feed (user selected terminator)</p> <p>Allows display of either Channel 1 or Channel 2, or Channel 3 which is CH1 minus CH2 expressed in dB. Includes second Model 952001 RF Probe, with Model 952004 Probe Tip and Model 952002 50 Ω BNC Adapter.</p>	0	1 mV	4	100 mV	1	3 mV	5	300 mV	2	10 mV	6	1000 mV	3	30 mV	7	3000 mV
0	1 mV	4	100 mV														
1	3 mV	5	300 mV														
2	10 mV	6	1000 mV														
3	30 mV	7	3000 mV														
04 Rear input	<p>Duplicates front panel Channel 1 input connector.</p>																

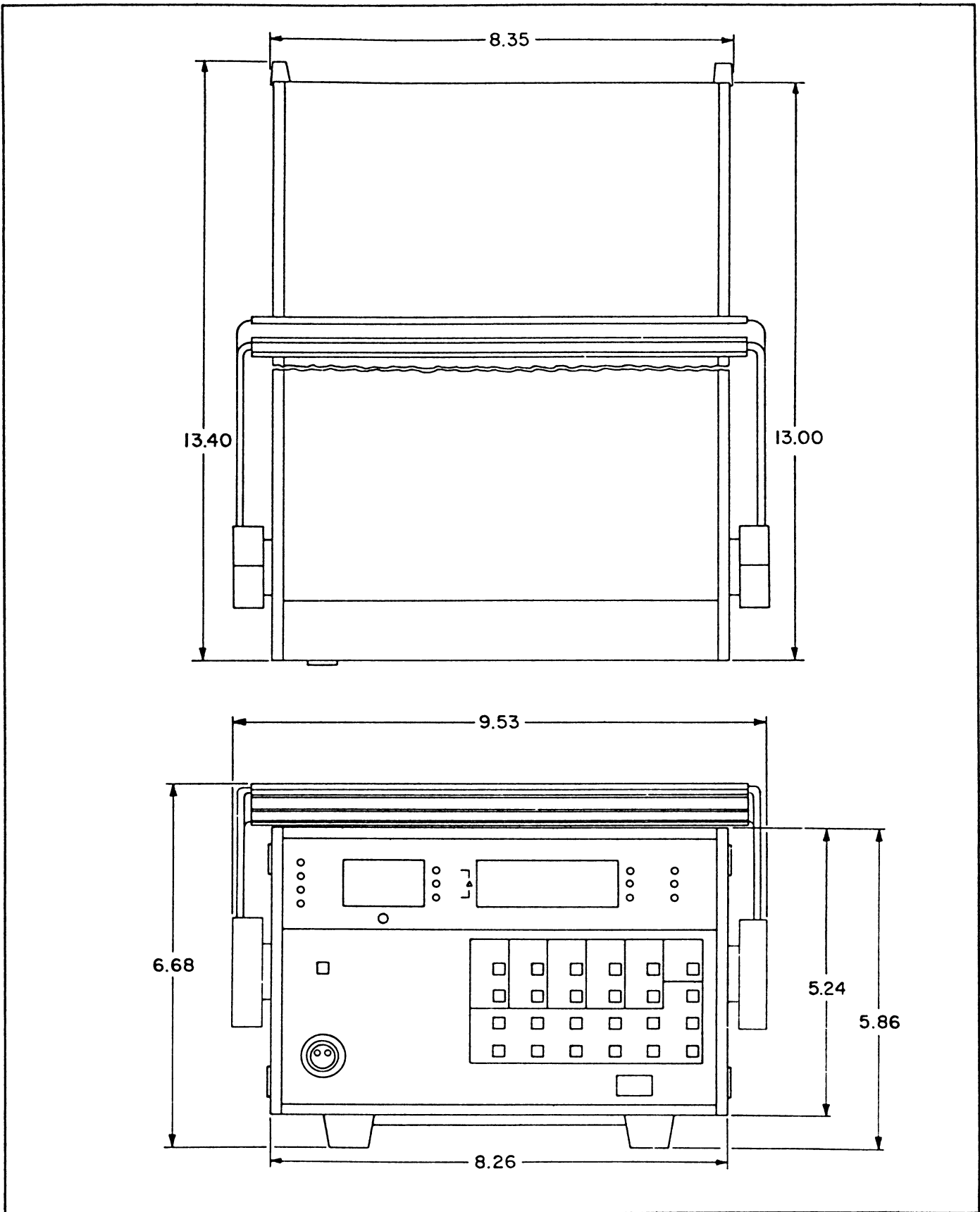

Figure 1-5. Outline Dimensions

SECTION II

OPERATION

2-1. GENERAL.

2-2. This section provides instructions for installation and operation of the instrument. It is recommended that the operator familiarize himself thoroughly with the material in this section before attempting to operate the instrument; otherwise, the full capabilities of the instrument may not be realized in use.

2-3. INSTALLATION.

2-4. **Unpacking.** The instrument is shipped complete with probe, and is ready for use upon receipt. Unpack the instrument carefully, and inspect it for any signs of shipping damage. Should any damage be noted, notify the carrier and the factory immediately.

NOTE

Save the packing material and container for possible use in reshipment of the instrument.

2-5. **Mounting.** For bench use, choose a clean, sturdy, uncluttered surface. For rack mounting, an accessory package, part number 950000, is available for mounting one instrument; a second accessory package, part number 950001, is available for mounting two instruments side-by-side.

2-6. **Power Requirements.** The instrument has a tapped power transformer which permits operation from 100, 120, 220, or 240 volt $\pm 10\%$, 50 to 400 Hz, single phase ac power sources. Power consumption is approximately 24 volt-amperes at 60 Hz.

2-7. **Cable Connections.** Interconnecting cable connections required depend upon the options installed and the system applications of the instrument. A line cord and a voltage probe are supplied with the instrument, a second voltage probe is supplied with option 9200A-03. Any other cables required must be supplied by the user. Cable connections that may be required are as follows:

a. **Recorder Output.** The rear-panel RECORDER connector (type BNC) provides an analog dc voltage that is linear with voltage over each decade range in the mV measurement mode, or linear in dB over the entire 80 dB range in any of the dB modes. Output impedance is approximately 9000 ohms. Maximum current capability is 1 milli-

ampere into 1000 ohms. Full scale dc voltage for each range in the mV mode is 10 volts. Output voltage in all dB modes is as follows:

Measured dBV	Output Voltage
+10	10 volts
0	9 volts
-10	8 volts
-20	7 volts
-30	6 volts
-40	5 volts
-50	4 volts
-60	3 volts
-70	2 volts

b. **Status Output.** Rear-panel connector P3 provides signal outputs for input disconnect during zeroing operations, and high and low dB limit signals. Pin connections are as follows:

Connector Pin	Signal
1	Common
2	Not used
3	Logic high indicates zeroing operation
4	Logic low if measured value is within dB limits; logic high if measured value is above high dB limit
5	Logic low if measured value is within dB limits; logic high if measured value is below low dB limit

2-8. OPERATING CONTROLS, INDICATORS, AND CONNECTORS.

2-9. Controls, indicators, and connectors used during operation of the instrument are shown in Figures 2-1 and 2-2. Table 2-1 lists their functions.

2.10. POWER APPLICATION.

2-11. The instrument is designed for operation from a 100, 120, 220, or 240 volt, 50 to 400 Hz, single phase ac power source. To apply ac power, proceed as follows:

a. Determine the line voltage at the ac power output receptacle.

b. Set the two slide switches on the rear panel to conform to the available a.c. line voltage.

TABLE 2-1. OPERATING CONTROLS, INDICATORS, AND CONNECTORS

Control, Indicator, or Connector	Figure and Index No.	Function	Control, Indicator, or Connector	Figure and Index No.	Function
LSN, ATN, REM, and TLK annunciators	2-1, 1	Provide indication of activity when IEEE 488 bus interface option 9200A-01A is in use.	SELECT keys	2-1, 11	Provide means for entering or recalling reference impedance (Z_0) for dB mode measurements, or for entering or recalling channel number (CHNL).
Meter	2-1, 2	Provides relative indication of voltage or dB for peaking and nulling operations.	dB REF LEVEL. dB key	2-1, 12	Provides means for entering or recalling a dB reference level.
CH1, CH3, and CH2 annunciators	2-1, 3	Indicate which channel has been selected for use.	Numerical, decimal point, and CHS keys	2-1, 13	Provide means for entering signed numeric data.
MODE keys	2-1, 4	Provide means for selecting display indication mode (mV, dB, dBmV, or dBV).	LINE switch	2-1, 14	Controls application of ac line power to instrument.
RANGE keys	2-1, 5	Provide means for selecting ranging mode (autorange or hold-on-range).	PROBE connector	2-1, 15	Provides means for connecting probe to channel 1 input of instrument.
LED display	2-1, 6	Four-digit LED display with minus sign and decimal point; provides numeric indication of measured voltage or dB level, or data entered or recalled through keyboard, or error messages.	ZERO key	2-1, 16	Provides means for automatic acquisition and storage of zero corrections for each range.
mV, dBV, and dBmV annunciators	2-1, 7	Indicate measurement units.	J1 connector	2-2, 1	Option: provides IEEE 488 bus connections when option 9200A-01A is installed.
dBm and dBr annunciators	2-1, 8	Indicate whether displayed measurement values in dB modes are absolute (dBm) or relative (dBr) values.	S1 switch	2-2, 2	Option: used to set address of instrument and termination characters when IEEE 488 bus option 9200A-01A is installed.
LIM annunciator	2-1, 9	Indicates when measured level is outside selected dB limits.	P3 connector	2-2, 3	Provides logic signal outputs for input disconnect during zeroing, high dB limit, and low dB limit.
LIMITS dB key	2-1, 10	Provides means for entering and recalling dB limits.			

TABLE 2-1. OPERATING CONTROLS, INDICATORS, AND CONNECTORS (Cont.)

Control, Indicator, or Connector	Figure and Index No.	Function	Control, Indicator, or Connector	Figure and Index No.	Function
Power connector	2-2, 4	Provides means for connecting instrument to ac power source; contains power fuse and voltage change card for 100, 120, 220, or 240 volt ac operation.	INPUT CHNL 2 connector	2-2, 6	Option: provides means for connecting probe to channel 2 input when option 9200A-03 is installed.
RECORDER connector	2-2, 5	Provides analog dc output, which is proportional to measured voltage or dB level, for application to recorder.	INPUT CHNL 1 connector	2-2, 7	Option: provides alternate means for connecting probe to channel 1 input when option 9200A-04 is installed.

c. Check the rating of the fuse in the rear-panel fuseholder. For operation from a 100 or 120 volt ac power source, the fuse should be a 0.3 ampere, MDL Slo-Blo type; for 220 or 240 volt operation, it should be a 0.2 amperes, MDL Slo-Blo type. If the rating of the fuse is incorrect, install a fuse of the correct rating in the fuseholder.

WARNING

This instrument is designed to operate from a 3-terminal (one ground) ac power receptacle. If only a 2-terminal ac power receptacle is available, use a 3-prong to 2-prong adapter. Connect the adapter ground wire to the power receptacle ground to eliminate a potential shock hazard to the operator.

d. Connect the power cord between the ac power connector on the rear panel of the instrument and the ac power receptacle (using an adapter if necessary).

2-12. PRELIMINARY CHECK OF INSTRUMENT.

NOTE

The following checkout procedure is intended merely to demonstrate that the major circuits of the instrument are operating before the instrument is placed in service. For a detailed check of the instrument against performance specifications, refer to paragraph 2-28.

2-13. To perform a preliminary operational check, proceed as follows:

- a. Set the LINE switch to the ON position.
- b. Check operation of the LED display and the numerical keys by pressing the following keys in the sequence indicated and noting the LED display:

Press	Display	Press	Display	Press	Display
CLR	0000	3	.0123	7	4567
•	0000.	CLR	0000	CLR	0000
0	000.0	4	0004	8	0008
1	00.01	5	0045	9	0089
2	0.012	6	0456	CHS	-0089

c. Connect the probe that is marked Channel 1 to the front-panel SENSOR connector.

d. Enter measurement parameters by pressing the following keys:

- 1 SELECT CHNL
- 0 dB REF LEVEL dB
- RANGE AUTO
- MODE dB
- 50 SELECT Z₀

e. Check to see that the dBm and CH1 annunciators are lighted.

f. With zero input to the probe, press the ZERO key. The instrument will go through an automatic zeroing cycle. During the zeroing cycle the display will blank; in approximately 7 seconds, the display will return and show cc 3, indicating that zeroing is complete and the input level is underrange.

NOTE

The 9200A will display seven error codes, as follows:

cc 1	entry too small
cc 2	entry too large
cc 3	measurement underrange
cc 4	measurement overrange
cc 5	zero acquisition out of range - excessive negative offset (hardware malfunction, e.g., input connector polarity reversed, or negative chopper offset)
cc 6	zero acquisition out of range - excessive positive offset (input too large)
cc 7	channel 3 over/underrange

g. Connect the Model 952001 probe to a low-impedance 1 MHz source, such as the Boonton Model 26A RF Millivoltmeter Calibrator, using the Model 91-6G unterminated BNC adapter supplied with the Model 26A. Set the output of the calibrator to 1000 millivolts, and press the following instrument keys:

5 LIMITS dB HI
 0 dB REF LEVEL dB
 50 SELECT Z₀

The CH1 annunciator should be lighted and the instrument display should indicate approximately 1000 mV.

NOTE

The Model 26A RF Millivoltmeter Calibrator is designed to operate into a high impedance load, such as the Model 952001 RF Probe. If the instrument is fitted with the Model 952009 RF Sensor, which has a built-in 50-ohm termination, it will be necessary to modify the output circuit of the Model 26A, as follows:

- a. Disconnect ac power to the Model 26A.
- b. Remove the bottom cover by removing the securing screw at the rear and then sliding the cover to the rear.
- c. Remove the TNC 50-ohm termination from the tee adapter at the output of the calibrator.
- d. Replace the cover, re-power, and proceed as follows:

1 SELECT CHNL
 MODE mV
 RANGE AUTO
 5 CHS LIMITS dB LO

h. Press the MODE dBmV key. The indication on the instrument display should be approximately 60.00 dBmV, and the LIM annunciator should be on.

i. Press the MODE dB key. The indication on the instrument display should be approximately 13.01 dBm, and the LIM annunciator should be on.

j. Press the numerical 1 key, then press the dB REF LEVEL dB key. The indication on the instrument display should be approximately 12.01 dB, and the LIM annunciator should be on.

k. Press the 1 and CHS numerical keys, then press the dB REF LEVEL dB key. The indication on the instrument display should be approximately 14.01 dB, and the LIM annunciator should be on.

l. Press the CLR key, then press the dB REF LEVEL dB key. The indication on the instrument display should be approximately 13.01 dBm, and the LIM annunciator should be on.

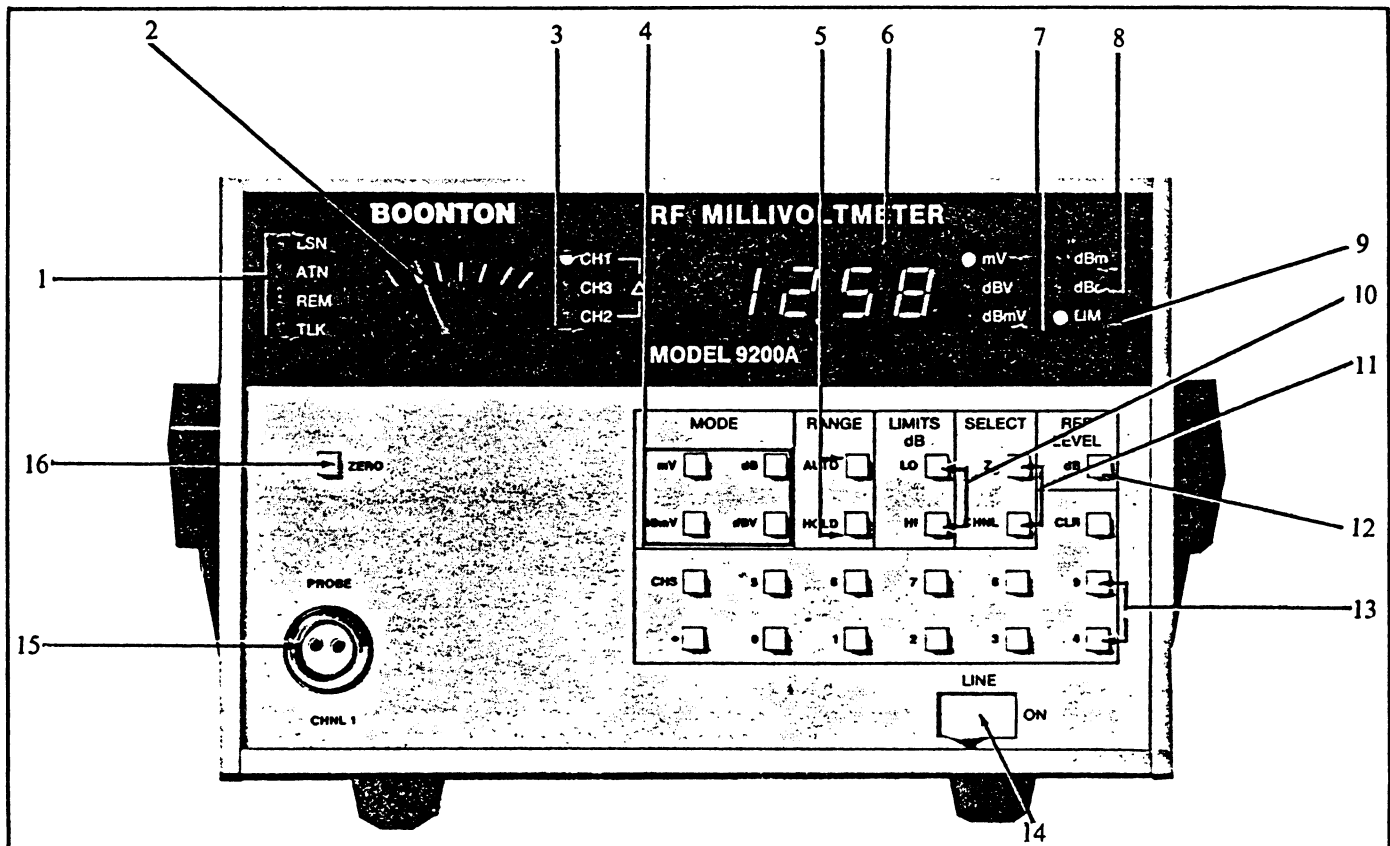

Figure 2-1 Front View of Instrument

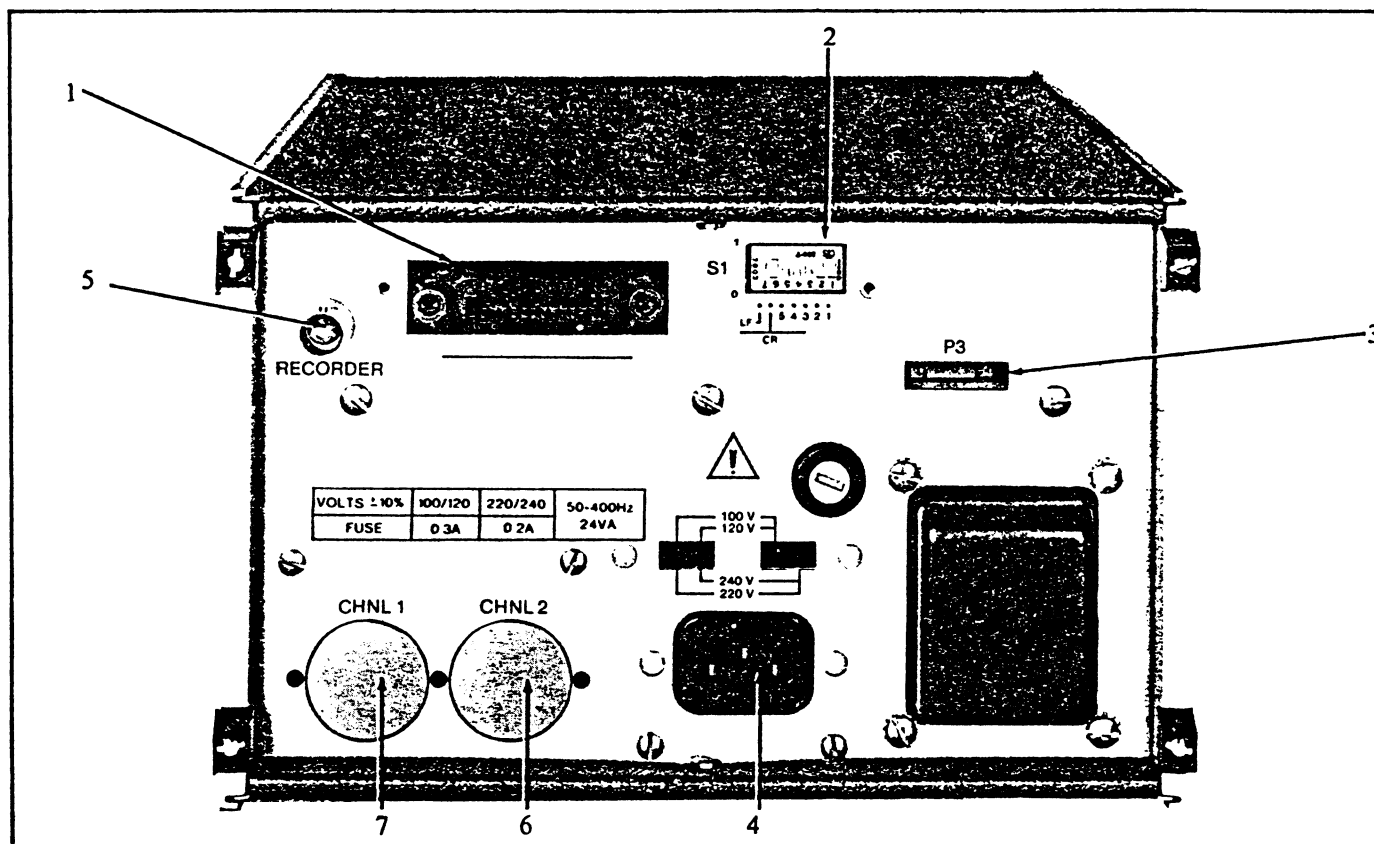

Figure 2-2 Rear View of Instrument

m. Press the MODE dBV key. The indication on the instrument display should be approximately 00.00 dBV, and the LIM annunciator should be off.

n. Set the output level of the calibrator to 300 millivolts. The instrument display should indicate approximately -10.46 dBV, and the LIM annunciator should be on.

o. Set the output level of the calibrator to 3 volts. The indication of the instrument display should be approximately 9.54 dBV, and the LIM annunciator should be on.

p. If the instrument is supplied with the second channel option (option 9200A-03), repeat steps g through o for channel 2, pressing the 2 SELECT CHNL key in step g in place of the 1 SELECT CHNL key, connecting probe 2 to the channel 2 input connector at the rear of the instrument, and connecting the channel 2 probe to the calibrator. A BNC tee can be used to connect both probes to the calibrator at the same time.

q. To check channel 3 operation with option 9200A-03 installed, proceed as follows:

1. Connect the channel 1 and channel 2 probes to the Model 26A RF Millivoltmeter Calibrator, using a BNC tee adapter and two model 91-6G unterminated BNC adapters supplied with the Model 26A.

2. Enter channel 1 and channel 2 measurement parameters by pressing the following keys in the given sequence:

1 SELECT CHNL
0 dB REF LEVEL dB
RANGE AUTO
MODE dB
50 SELECT Z₀
2 SELECT CHNL
0 dB REF LEVEL dB
RANGE AUTO
MODE dB
50 SELECT Z₀

3. Set the output level of the calibrator to 1000 millivolts, and press the 3 SELECT CHNL key. The indication on the instrument display should be approximately 00.00 dB, which is the difference in dB with channel 2 as the reference. If the limits chosen in step g have not been changed, the LIM annunciator will be on.

NOTE

The dB mode last chosen for each channel prior to channel 3 selection is operative after channel 3 selection.

4. Set the output level of the calibrator to 300 millivolts. The LIM annunciator will go off.

Section II Operation

r. Turn off the calibrator and disconnect the probe(s) from the calibrator.

2-14. OPERATING PROCEDURES.

2-15. Programming Measurement Parameters.

a. **General.** Measurement parameters for each channel of the instrument are entered into the microprocessor through the front-panel keyboard. To eliminate the need for repeated reprogramming, parameters entered through the keyboard are stored in non-volatile memory, and the stored parameters are unaffected by instrument turn-off and turn-on. It is important to remember that the last used parameters are stored in the instrument because these stored parameters could cause what appear to be erroneous indications when subsequent measurements that require different parameters are made. Measurement parameters may be changed at any time. The following keys may be used to recall the last entered value for the corresponding functions:

LIMITS dB LO, LIMITS dB HI,
SELECT Z_0 , SELECT CHNL and
dB REF LEVEL dB

NOTE

Entered measurement parameters apply only to the channel in use at the time that the parameter entries were made. If the instrument is equipped with the second channel option (option 9200A-03), different measurement parameters may be entered for channel 1 and channel 2. When either channel is selected thereafter, measurement parameters that had been entered for that channel are invoked automatically by the microprocessor.

b. **Probe Selection.** The Model 9200A is supplied with either the Model 952001 high impedance probe or the Model 952009 50-ohm sensor as ordered for channel 1 (and channel 2, option 9200A-03 if ordered). Each channel is dedicated to the type of probe supplied. Either channel can be operated with the other type probe but will require recalibration for that type of probe and the specific probe to be used. This procedure is covered in paragraphs 4-38, 4-39, 4-40.

c. **Use of Numerical Keys.** The numerical keys are used to enter values for LIMITS dB, SELECT, and dB REF LEVEL dB functions. When any numerical key is pressed, the microprocessor interrupts the measurement operation to accept new data. Numerical values are entered in normal sequence, and keyed-in values enter the instrument display from right to left. Up to four digits, plus decimal point and minus sign, can be entered; entries exceeding four digits are

ignored. Pressing the decimal-point key places a decimal point after the right-most digit in the instrument display. Pressing the CHS key changes the sign of the entry (plus becomes minus, or minus becomes plus); the plus sign is not displayed. If an error is made during entry of numerical values, press the CLR key and repeat the data entry process. When the instrument display shows the desired numerical value, pressing the applicable LIMITS dB, SELECT, or dB REF LEVEL key will cause the microprocessor to store the keyed-in value and return automatically to the measurement cycle.

d. **MODE Selection.** The MODE keys enable the operator to select the desired measurement mode. When the MODE mV key is pressed, measurement values are displayed in millivolts. When the MODE dBmV key is pressed, measured levels are displayed in dB referred to 1 millivolt. When the MODE dBV key is pressed, measured levels are displayed in dB referred to 1 volt. When the MODE dB key is pressed (and a 0 dB reference level has been entered), measured levels are displayed in dB referred to the voltage that produces 1 milliwatt in the selected Z_0 reference impedance (the Z_0 value must be entered through the keyboard). The displayed numerical values may be expressed as follows:

$$\text{dB} = 20 \log \frac{e_{\text{measured}}}{e_{\text{reference}}}$$

$$\text{For dBm, } e_{\text{reference}} = (Z_0 \times 10^{-3})^{1/2}$$

In the dB mode, entering a dB reference level other than 0 causes lighting of the dB_r annunciator, and displayed dB mode measurement values represent dB with respect to the selected reference level. Resolution of the instrument in any dB mode is 0.01 dB.

e. **RANGE Selection.** The RANGE keys enable the operator to select either automatic ranging or a range-hold function. The auto-ranging function, which is most effective when measuring unknown or widely varying voltage or dB levels, is activated by pressing the RANGE AUTO key; the microprocessor automatically steps to the measurement range that provides the best resolution display. Ranging time is a function of a number of factors such as absolute level, change in level, analog response time, and direction of change. The range-hold function is useful when a series of measurements of approximately the same level are to be made; selecting this mode eliminates delays due to ranging time. When the RANGE HOLD key is pressed, the instrument remains on the measurement range that was active at the time the key was pressed.

f. **LIMITS dB Selection.** The LIMITS dB keys enable the operator to program high and low dB limits into the instrument.

1. High and low limits may be entered for each channel. When the displayed level (function of dB mode and dB reference level) exceeds either limit, the LIM annunciator is activated and a logic-level signal at rear-panel connector P3 is activated.

2. Entered dB limits operate from the displayed value. If the mV mode is chosen for either or both channels, the last dB mode chosen previously for each channel is operative.

3. In channel 3 operation, the above statements are true. The first limit exceeded, regardless of channel, activates the LIM annunciator.

4. Limits on one or both channels can effectively be defeated or disabled by selecting limit values that will never be exceeded. Maximum legal values are ± 99.99 dB.

5. Limits are entered by keying in the numerical value in dB, using the numerical keys, and then pressing the LIMITS dB LO or LIMITS dB HI key, as applicable.

Example: To enter a low limit of -31.34 dB:

Press	Display
3	0003
1	0031
.	0031.
3	031.3
4	31.34
CHS	-31.34
LIMITS dB LO	Reverts to measurement in mode selected.

g. **SELECT Function Selection.** The SELECT keys are used by the operator to specify the number of the measurement channel and the reference impedance (Z_0) for dB measurements.

NOTE

Selecting a channel also selects probe data and measurement parameters that had been entered into non-volatile memory for that channel.

1. The basic instrument contains only one measurement channel. This channel is designated channel 1, and the front panel SENSOR connector provides the input to this channel. An option is available for the addition of a second measurement channel. When this option (option 9200A-03) is included, the additional measurement channel is designated channel 2, and the rear panel INPUT channel 2 connector provides the input to this second channel.

2. To further enhance the usefulness of the instrument, a channel 3 operation may be exercised if the instrument is

equipped with option 9200A-03. The indication in channel 3 mode is:

$$\text{Display} = \left[\begin{array}{c} \text{Channel 1} \\ \text{dBmV} \\ \text{or} \\ \text{dBV} \\ \text{or} \\ \text{(dB - dB REF LEVEL)} \end{array} \right] - \left[\begin{array}{c} \text{Channel 2} \\ \text{dBmV} \\ \text{or} \\ \text{dBV} \\ \text{or} \\ \text{(dB - dB REF LEVEL)} \end{array} \right]$$

The dB mode operative for each channel in channel 3 operation is the last dB mode chosen for that channel prior to selection of channel 3 operation. This is true even if the mV mode is chosen prior to channel 3 selection. Mixed modes are also possible, that is, either channel may be operating in any of its modes (mV, dBmV, dBV, or dB). If either or both channels are operating in the dB mode, the dB REF LEVEL dB function is also operative. Examples of channel 3 operation are listed in Table 2-2.

3. Channel 1 measurements, channel 2 measurements, or the channel 3 function can be selected using the numerical keys and the SELECT CHNL key.

Example: To select the channel 1 input for measurement:

Press	Display
1	0001
SELECT CHNL	Reverts to measurement.

4. The SELECT Z_0 key enables the operator to enter a desired reference impedance for dB mode measurements. (When the MODE dB key is pressed, measured input levels are displayed in dB referred to the voltage that produces 1 milliwatt of power in the selected reference impedance.) Valid Z_0 values are 50 through 600 ohms.

Example: To select a reference impedance of 50 ohms:

Press	Display
5	0005
0	0050
SELECT Z_0	Reverts to measurement.

h. **dB REF LEVEL Selection.** The following standard reference levels are operative in the dB modes:

Mode	Level (0 dB)	Annunciator
dBmV	1 mV	dBmV
dBV	1 V	dBV
dB (Z_0)	dB ($Z_0 \times 10^{-3}$) ^{1/2}	dBm

Entering a number other than 0 into the dB REF LEVEL dB results in this number becoming the reference level for the dB mode. The display will indicate reference level, and the dB annunciator will be activated. The dB reference level **affects the dB mode only**. The dB reference level may be entered while any mode is being used, but the result of the entry will be apparent only when returning to the dB mode.

TABLE 2-2. EXAMPLES OF CHANNEL 3 MEASUREMENTS

No.	Channel 1					Channel 2					Channel 3 Display
	Input	Mode	Z ₀	dB REF LEVEL dB	Display	Input	Mode	Z ₀	dB REF LEVEL dB	Display	
1	1000 mV	mV	-	0	1000 mV	1000 mV	mV	-	0	1000 mV	(See Note)
2		dBmV	-	0	60.00 dBmV		dBmV	-	0	60.00 dBmV	00.00 dBr
3		dBv	-	0	00.00 dB		dBmV	-	0	60.00 dBmV	-60.00 dBr
4		dB	50	0	13.01 dBm		dB	50	0	13.01 dB	00.00 dBr
5		dB	50	5	8.01 dBr		dB	50	0	13.01 dB	-05.00 dBr
6		dB	50	5	8.01 dBr		dBmV	50	0	60.00 dBmV	-51.99 dBr
7		mV	50	5	1000 mV		dBmV	50	0	60.00 dBmV	-51.99 dBr
8		mV	50	5	1000 mV		mV	50	0	1000 mV	-51.99 dBr

NOTES:

- For No. 1 measurement, the channel 3 indication is a function of previously selected dB modes, unknown at this time.
- For No. 2 measurement, the channel 3 indication = 60 dBmV - 60 dBmV = 0 dBr.
- For No. 3 measurement, the channel 3 indication = 0 dBV - 60 dBmV = -60 dBr.
- For No. 4 measurement, the channel 3 indication = 13.01 dBm - 13.01 dBm = 0 dBr.
- For No. 5 measurement, the channel 3 indication = (13.01 dBm - 5 dB) dBr - 13.01 dBm = -5 dBr.
- For No. 6 measurement, the channel 3 indication = (13.01 dBm - 5 dB) dBr - 60 dBmV = -51.99 dBr.
- No. No. 7 and No. 8 measurements, the channel 3 indication is the same as for the No. 6 measurement because if the mV mode was chosen for channel 1 and/or channel 2 prior to channel 3 selection, that channel will revert to the dB mode used prior to selection of the mV mode.

1. To display dBr to a reference level of -15.3 dB, for example:

Press	Display	Annunciators	
MODE dB	Measurement	dBm	dBr
CLR	0000	Lighted	Off
dB REF LEVEL	dB Measurement	Lighted	Off
1	0001	Lighted	Off
5	0015	Lighted	Off
•	0015.	Lighted	Off
3	015.3	Lighted	Off
CHS	-015.3	Lighted	Off
dB REF LEVEL	dB Measurement	Off	Lighted

NOTE

Maximum display capability for dBr is ±99.99 dB.

2. To return to a dBm measurement:

Press	Display	Annunciators	
0 to CLR	0000	dBm	dBr
dB REF LEVEL	dB Measurement	Lighted	Off

2-16. Zeroing the Instrument. For greatest accuracy, especially on the more sensitive ranges, the instrument must be zeroed. To eliminate the need for tedious and often inaccurate manual zeroing, the instrument incorporates an automatic zeroing capability. When automatic zeroing is initiated, the microprocessor reads, averages, and stores zero corrections for each measurement range of the instru-

ment, and applies the proper zero correction for the range in use for all subsequent measurements. Zero corrections are most important on the more sensitive ranges of the instrument. During instrument warmup periods and during use in environments with varying ambient temperatures, the instrument should be zeroed frequently if measurements are being made on the lower ranges. To zero the instrument, proceed as follows:



Never press the ZERO key with a signal applied to the probe. To do so will result in erroneous zero corrections and inaccurate subsequent measurements. If the input exceeds normal zero offsets, error flag cc 6 will be displayed when automatic zeroing is initiated; remove the input signal and re-zero the instrument.

a. Remove all input signal to the probe. This can be done by unscrewing the probe tip until the tip just breaks contact with the internal connection, leaving the metal shell engaged with the probe body threads. Alternatively, the probe tip can be removed and a Model 952002 50-ohm adapter connected in its place.

b. Press the ZERO key. The automatic zeroing cycle takes approximately 7 seconds; the microprocessor computes and stores zero corrections during this time period. When the ZERO key is pressed, a logic signal is activated at rear-panel connector J3; this signal can be used to initiate turn-off of the device to which the instrument probe is

connected if such operation is desired. When zeroing is complete, the instrument display shows cc 3 in all dB modes, indicating input underrange. In the mV mode, the underrange indication does not appear; the instrument display shows the "zero condition." This is composed of residual noise and offsets and, ideally, should show + and - excursions of similar amplitude less than 100 counts.

2-17. Making Measurements. Once the instrument has been programmed and zeroed, it is ready for voltage or dB level measurements. Merely connect the probe to the source whose voltage or dB level is to be measured; the measured level will be displayed directly.

2-18. APPLICATION NOTES.

2-19. Overload Limits.

a. The Model 952001 RF Probe supplied with the instrument is overload-protected to 10 volts ac and 400 volts dc. **Exceeding these limits may result in permanent damage.**

b. The Model 952002 50-Ohm BNC Adapter supplied with the instrument should not be subjected to continuous overload of more than 10 volts (dc + RMS ac) in order to avoid excessive heating of the terminating resistor.

c. Where voltages above the specified overload limits are likely to be encountered, use the Model 952005 100:1 Voltage Divider (optional accessory). Maximum rating of the voltage divider is 1000 volts (dc + peak ac).

d. The terminated Model 952009 RF Probe is overload protected to 4 volts ac and 400 volts dc. **Exceeding these limits may result in permanent damage.**

2-20. Connection Recommendations.

a. The Model 952001 probe is equipped with a detachable tip and ground lead. For measurement of signals below approximately 100 MHz, this tip provides a convenient means for making both signal and ground connections.

b. For frequencies above 100 MHz, the probe tip should not be used because the series impedances of the connection will affect the voltage level at the probe and cause an error in measurement. For high impedance voltage measurements, connection should be made directly to the center contact of the RF probe, with the ground connection kept as short as possible. For matched impedance measurements, one of the various terminated adapters, tee adapter, or Model 952009 Probe should be used (See Figure 2-3).

2-21. Low-Level Measurements. The instrument will provide reliable, reproducible measurements of signal levels as low as 200 microvolts. Useful indications extend down to

50 μ V. Zeroing of the instrument is essential when using the lower ranges in order to achieve the specified accuracy. Zeroing is also strongly recommended for all ranges up to 30 millivolts. Refer to paragraph 2-16 for the zeroing procedure.

2-22. Temperature Effects.

a. The accuracy specifications for the instrument apply over a temperature range of 0°C to 50°C. Outside these limits operation of the instrument is possible, but appreciable inaccuracies can be expected; however, no permanent change in probe characteristics will result from any reasonably high or low temperature exposure.

b. It should be noted that inaccuracies of measurement resulting from temperature effects may occur shortly after soldering to the RF probe tip, or measuring with the probe in the vicinity of heat sources such as resistors, heat sinks, and so forth.

c. When making low-level measurements (below approximately 2 millivolts), it is important to make sure that the probe has attained a uniform temperature throughout its body. A temperature gradient between the inside and outside of the probe can generate a small thermal voltage that may add to the dc output of the detector diodes.

2-23. Hum, Noise, and Spurious Pickup. When measuring low-level signals, precautions should always be taken to avoid the possibility of measurement errors resulting from hum, noise, or stray RF pickup. Although all low-frequency hum and noise are attenuated at the input, unwanted high-level signals could still possibly cause errors. In some cases it may be necessary to provide extra shielding around the probe connection to reduce stray pickup. Some typical sources of spurious radiation are induction or dielectric heating units, diathermy machines, and local radio transmitters.

2-24. Recorder Output. The dc output provided at the rear-panel RECORDER connector may be used to drive an XY recorder for swept measurements, or a strip chart recorder for monitoring applications. (Refer to paragraph 2-7a.)

2-25. Correction Curve for Model 952003 50-Ohm N Tee Adapter. When using the optional Model 952003 50-Ohm N Tee Adapter, the input voltage to the adapter is indicated directly on the instrument. To obtain the correct output voltage from the adapter, subtract the correction shown in Figure 1-4 from the input voltage, in dB, indicated on the instrument. Corrections are not required if the Model 952003 is terminated in 50 ohms.

2-26. Correction Curve for Model 952007 75-Ohm N Tee Adapter. When using the optional Model 952007 75-Ohm

Section II Operation

N Tee Adapter, the input voltage to the adapter is indicated directly on the instrument. To obtain the correct output voltage from the adapter, subtract the correction shown in Figure 1-4 from the input voltage, in dB, indicated on the instrument. Corrections are not required if the Model 952007 is terminated in 75 ohms.

2-27. MINIMUM PERFORMANCE STANDARDS.

2-28. Test Equipment Required. A 1 MHz low-impedance voltage calibration source, such as the Boonton Electronics Corporation Model 26A RF Millivoltmeter Calibrator, and a dc voltmeter or oscilloscope capable of measuring 0 to +10 volts are required.

NOTE

The Model 26A RF Millivoltmeter Calibrator is designed to operate into a high impedance load, such as the Model 952001 RF Probe. If the instrument is fitted with the Model 952009 RF Sensor, which has a built-in 50-ohm termination, it will be necessary to modify the output circuit of the Model 26A, as follows:

- a. Disconnect ac power to the Model 26A.
- b. Remove the bottom cover by removing the securing screw at the rear and then sliding the cover to the rear.
- c. Remove the TNC-50-ohm termination from the tee adapter at the output of the calibrator.
- d. Replace the cover, re-power, and proceed as follows:

2-29. Preliminary Setup.

- a. Turn on the instrument and calibrator and allow sufficient warmup time. If either unit had been stored at ambient temperatures substantially different from the ambient temperature at the test facility, make sure enough time is allowed for each device to reach ambient temperature.
- b. Set the calibrator output to zero. Attach the channel 1 RF probe to the front-panel SENSOR connector on the instrument, and connect the probe input to the calibrator using an open-circuit BNC Model 91-6G adapter supplied with the calibrator.

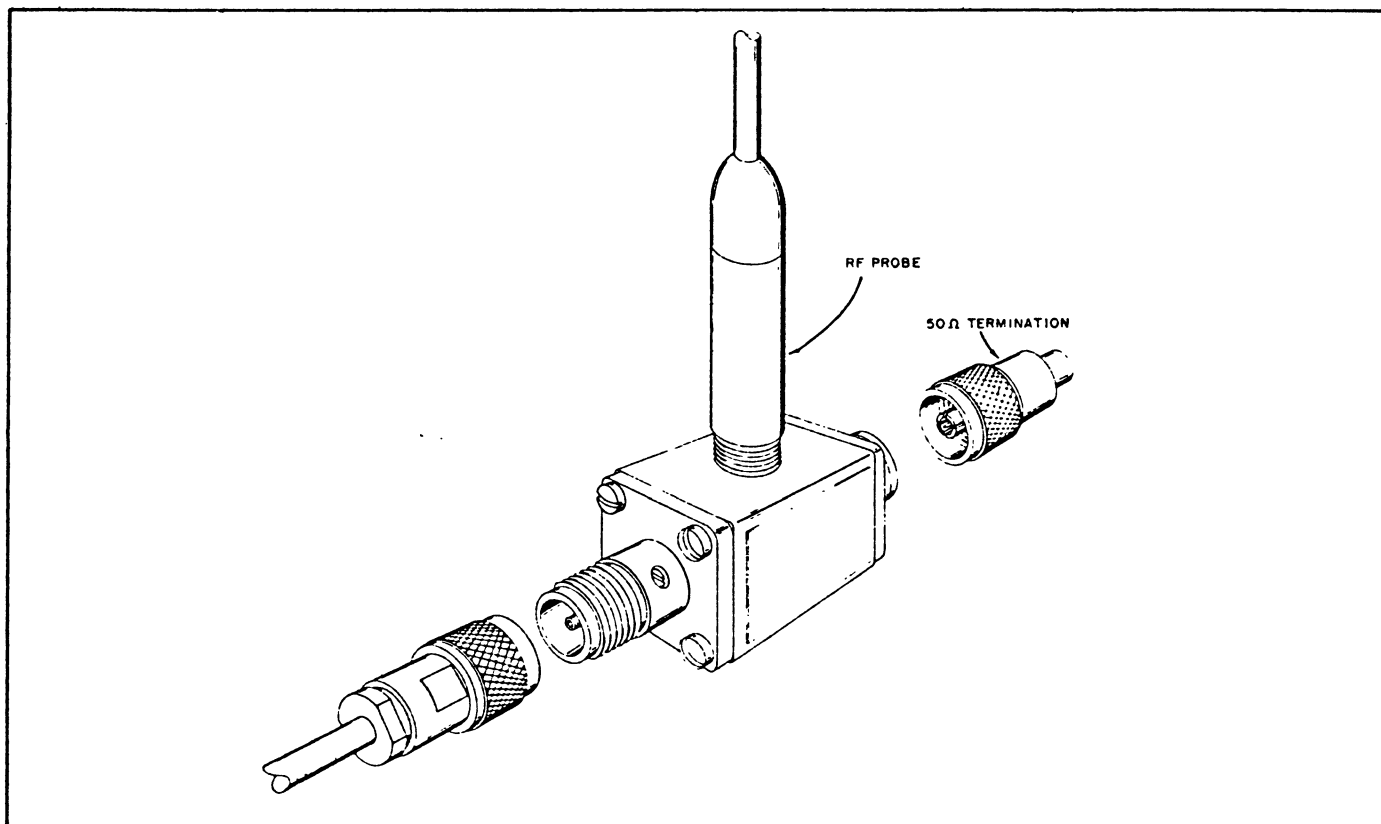

Figure 2-3 Attachment of Model 952003 50-Ohm N Tee Adapter To Model 952001 Probe and Model 952014 50-Ohm Termination.

c. Key in the following measurement parameters through the instrument keyboard:

```
1 SELECT CHNL
MODE mV
RANGE AUTO
LIMITS dB - any
0 dB REF LEVEL dB
```

NOTE

Maintain the measurement parameters specified above for each of the following tests unless specifically directed otherwise.

2-30. Automatic Zero Function Test. To check the automatic zeroing function of the instrument, proceed as follows:

a. Ascertain that the signal input to the probe is zero. (Press the white 0 key on the calibrator.)

b. Press the ZERO key on the instrument and ascertain that the following results are obtained:

1. The logic signal level at pin 3 of rear-panel connector P3 should switch from a logic low to a logic high when the ZERO key is pressed. It should remain high throughout the zeroing period, and it should return to a logic low at the end of the zeroing period.

2. The instrument display should blank for approximately 7 seconds after the ZERO key is pressed. At the end of the zeroing period, the display should show cc 3 for all dB modes, or a residual reading for the mV mode.

NOTE

In the mV mode, the residual reading after zeroing is composed of random noise and residual offsets. It should ideally show plus and minus excursions of less than 100 counts.

2-31. Autoranging Mode Test. To check the autoranging function of the instrument, set the calibrator to each of the values listed below and ascertain that the instrument display agrees with each input level within $\pm 2\%$:

```
3000 mV
1000 mV
300 mV
100 mV
30 mV
10 mV
3 mV
1 mV
```

2-32. Range Hold Function Test. To check the range hold function of the instrument, proceed as follows:

- a. Set the output level of the calibrator to 1000 mV.
- b. Press the RANGE HOLD key and then press the MODE mV key.
- c. Ascertain that the instrument display shows 1000 mV $\pm 2\%$.
- d. Set the calibrator output to each of the following levels in succession, and ascertain that the corresponding listed indication is obtained on the instrument:

Voltage Level	Instrument Indication
3000 mV	cc 4
1000 mV	1000. mV
300 mV	0300. mV
100 mV	cc 3

NOTE

When the range hold function is selected, input levels greater than the measurement decade operative when the selection was made result in display of an overrange indication; lower input levels result in a decrease in the number of significant digits in the display. If the indication is less than 18.5% of full scale, error message cc 3 is displayed. Note that in the range or hold mode the decimal point and the annunciator remain fixed.

2-33. Basic Instrument Accuracy Test. To check the basic accuracy of the instrument, proceed as follows:

a. With zero input to the probe (white 0 button on the calibrator pressed), zero the instrument by pressing the ZERO key.

b. Press the MODE mV key and the RANGE AUTO key after zeroing has been completed.

c. Set the output level of the calibrator to each of the following full-scale levels in succession, and ascertain that the instrument display agrees within the accuracy shown:

Full Scale Values	
Voltage Levels	Accuracy of Indication
3000 mV	$\pm 1\% \pm 1$ count \pm calibrator uncertainty
1000 mV	$\pm 1\% \pm 1$ count \pm calibrator uncertainty
300 mV	$\pm 1\% \pm 1$ count \pm calibrator uncertainty
100 mV	$\pm 1\% \pm 1$ count \pm calibrator uncertainty
30 mV	$\pm 1\% \pm 1$ count \pm calibrator uncertainty
10 mV	$\pm 1\% \pm 1$ count \pm calibrator uncertainty
3 mV	$\pm 1\% \pm 1$ count \pm calibrator uncertainty
1 mV	$\pm 2\% \pm 2$ counts \pm calibrator uncertainty

Section II
Operation

d. Set the output level of the calibrator to 1000 millivolts and press the RANGE HOLD key. Then, set the output level of the calibrator to each of the following values in succession, and ascertain that the instrument display agrees with the applied level within the tolerance shown. After completing this test, press the RANGE AUTO key.

Voltage Levels	Downscale Values	Accuracy of Indication
1000 mV	±1%	±1 count ±calibrator uncertainty
900 mV	±1%	±1 count ±calibrator uncertainty
800 mV	±1%	±1 count ±calibrator uncertainty
700 mV	±1%	±1 count ±calibrator uncertainty
600 mV	±1%	±1 count ±calibrator uncertainty
500 mV	±1%	±1 count ±calibrator uncertainty
400 mV	±1%	±1 count ±calibrator uncertainty
300 mV	±1%	±1 count ±calibrator uncertainty

2-34. dB Mode Check. To check the dB modes of operation, proceed as follows:

a. Press the following keys:

1 (or 2) SELECT CHNL
RANGE AUTO
MODE mV
50 SELECT Z₀
0 dB REF LEVEL dB

b. Set the calibrator output to 1000 mV. The indication on the instrument display should be 1000 mV ±2%.

c. Press the MODE dBmV key. The indication on the instrument display should be 60.00 ±0.18 dBmV.

d. Press the MODE dBV key. The indication on the instrument display should be 00.00 ±0.18 dBV.

e. Press the MODE dBm key. The indication on the instrument display should be 13.01 ±0.18 dBm.

2-35. dB Reference Level Function Test. To check the dB reference level function of the instrument, proceed as follows:

a. Set the output level of the calibrator to 1000 mV.

b. Press the MODE dB key and ascertain that the instrument display indicates approximately 0 dB.

c. Enter a ±13 dB reference level by pressing the following keys:

1
3
dB REF LEVEL dB

d. Ascertain that the instrument display now indicates approximately 0 dB. The dB annunciator should be off, and the dBm annunciator should be lighted.

e. Reset the instrument to indicate dB by pressing the following keys:

0 (or CLR)
dB REF LEVEL dB

f. Ascertain that the instrument display again indicates approximately 13 dB. The dB annunciator should be lighted, and the dBm annunciator should be off.

2-36. dB Limit Test. To check operation of the dB limit circuits, proceed as follows:

a. Set the output level of the calibrator to 1000 mV.

b. Press the MODE dBV key.

c. Enter a +1 dB high limit by pressing the following keys:

1
LIMITS dB HI

d. Enter a -1 dB low limit by pressing the following keys:

1
CHS
LIMITS dB LO

e. Ascertain that the LIM annunciator is off.

f. Set the output level of the calibrator to 800 mV. The LIM annunciator should light. The logic level at pin 5 of rear-panel connector P3 should be high; the logic level at pin 4 should be low.

g. Set the output level of the calibrator to 1200 mV. The LIM annunciator should light. The logic level at pin 4 of rear-panel connector P3 should be high; the logic level at pin 5 should be low.

NOTE

Limits can be entered only in terms of dB, not voltage; however, the limit function operates in either the dB modes or the mV mode.

SECTION III

THEORY OF OPERATION

3-1. GENERAL.

3-2. The instrument is a general-purpose RF millivoltmeter capable of measuring RF voltage levels from 200 microvolts to 3 volts. It is designed to operate with Boonton Electronics Corporation Model 952001 and 952009 RF probes. The lowest usable frequency for calibrated measurements is 10 kHz; the highest frequency is 2.5 GHz. Useful response for relative measurements can be obtained to beyond 8 GHz.

3-3. The instrument is completely solid-state and employs a microprocessor for versatility and convenience of use. The microprocessor is controlled by a permanently stored internal program. Desired operating parameters are entered by means of a front-panel keyboard. Use of a microprocessor permits automation of numerous functions, such as zeroing, range selection, unit conversion, dB limit testing, relative dB measurements, etc. Measured values are displayed directly on a 4-digit LED display in terms of mV, dBmV, dBV, dBm, or dBr (relative dB). Annunciators associated with the display indicate the unit of measurement. An analog meter is also provided for relative voltage measurements; this feature simplifies such operations as nulling and peaking. A dc voltage that is proportional to the measured value is available at a rear-panel connector.

3-4. OVERALL BLOCK DIAGRAM.

(See Figure 3-1.)

3-5. Probe. RF levels to be measured are applied to an external probe, which connects to the SENSOR connector on the front panel of the instrument. The probes convert the applied RF voltage to a dc voltage. The dc voltage is supplied to the input module of the instrument.

3-6. Input Module. The input module receives the dc voltage developed by the probe. Operating under control of the control module, the input module converts the dc voltage to an ac voltage, amplifies this ac voltage, converts it to an analog dc voltage, and converts this to a digital signal. If the autoranging function of the instrument has been selected, the gains of the amplifiers in the input module are adjusted automatically by the control module to accommodate any voltage level within the range of the instrument. The digital output signal of the input module is supplied to the control module for additional processing; an analog dc output signal is developed from the digital

signal and this analog dc signal is applied to the analog meter in the display module for relative voltage measurements, and to a rear-panel connector for application to a peripheral recorder.

3-7. Control Module. The control module consists primarily of a preprogrammed microprocessor. The microprocessor accepts and stores measurement parameter commands entered through the front-panel keyboard, and controls operation of the internal circuits of the instrument in accordance with its program and keyed-in commands. The microprocessor performs measurement value corrections based on stored zero corrections and stored gain and range linearization factors, unit conversions based on selected measurement modes, and dB limit determination. The microprocessor also performs key-initiated automatic zeroing. The processed digital signal, which defines the final measurement value, is applied to a data bus and to the display module.

3-8. Display Module. The display module contains the keyboard and LED display circuits. Parameters to be used for measurements can be entered at any time through the keyboard, and can also be recalled for checking. Keyed-in values are read and stored by the microprocessor, and keyed-in numerical values are shown on the display during parameter entry. Computed voltage levels are processed by the microprocessor in accordance with the keyed-in data; the digital values representing the final computer measurement values are decoded by the display module circuits to produce a direct LED readout of measured values and to activate the proper annunciators.

3-9. Power Supply Module. The power supply module provides all dc voltages required for operation of the internal circuits of the instrument. It also provides a reset signal to the control module when power is applied, and an interrupt signal if an undervoltage condition is detected. The power supply module can be powered from a 100, 120, 220, or 240 volt, 50 to 400 Hz, ac power source.

3-10. Optional Modules. A variety of standard options is available to increase further the versatility of the instrument. Two of these optional modules are included in Figure 3-1.

a. A second input module (option 9200A-03) can be added to the instrument to permit measurement of voltage levels at two locations without the need for repeated switching of probe connections. The input connector for this

Section III
Theory of Operation

optional module is located on the rear panel of the instrument. The second input module also permits display of the difference between the levels at the two locations, expressed in dB.

b. The interface module (option 9200A-01) provides an IEEE 488 bus interface for remote control of instrument operation and for remote access to measured values.

3-11. DETAILED THEORY OF OPERATION, PROBE CIRCUITS.

3-12. The RF probes used with the instrument convert RF to dc. The RF voltage applied to the probes is rectified by a full-wave detector that employs factory-selected diodes with special characteristics, including low capacitance and controlled thermal offsets. The resulting dc voltage is a function of the applied RF voltage.

3-13. A full-wave detector, unlike a single-diode detector, permits measurement of highly asymmetric waveforms without substantial error. When a voltage of asymmetric waveform is impressed on a single-diode detector circuit, whether or not the portion of the waveform that turns on the diode is restricted to the square-law region of the diode's

characteristic, the recovered dc voltage is dependent upon the phase of the input voltage. Consider a positive pulse of low duty cycle applied to the anode of a diode detector. The recovered dc voltage is a function of the polarity, amplitude, and duration of the pulse. If the pulse is inverted, it drives the diode into a reverse bias condition and the recovered dc voltage is zero. A full-wave detector circuit, on the other hand, yields an equal amount of dc irrespective of the polarity of the input pulse. The average voltage of a pulse obviously does not depend upon the phase of the pulse. The response of a single-diode detector, square-law characteristic notwithstanding, cannot reflect this; a full-wave detector circuit does.

3-14. Probe response is true RMS for inputs below 30 mV. Above this voltage level, the probe response gradually changes, approaching peak-to-peak at the higher voltage levels; however, the voltage data is digitally shaped in the instrument to indicate RMS voltage, provided that the input is reasonably sinusoidal as is the case with CW and FM signals. The body of the probe has been designed and fabricated to eliminate any cavity resonance effects within the calibrated frequency range and to minimize noise. The dc output voltage from the probe is applied to the SENSOR connector of the instrument through a low-noise probe cable.

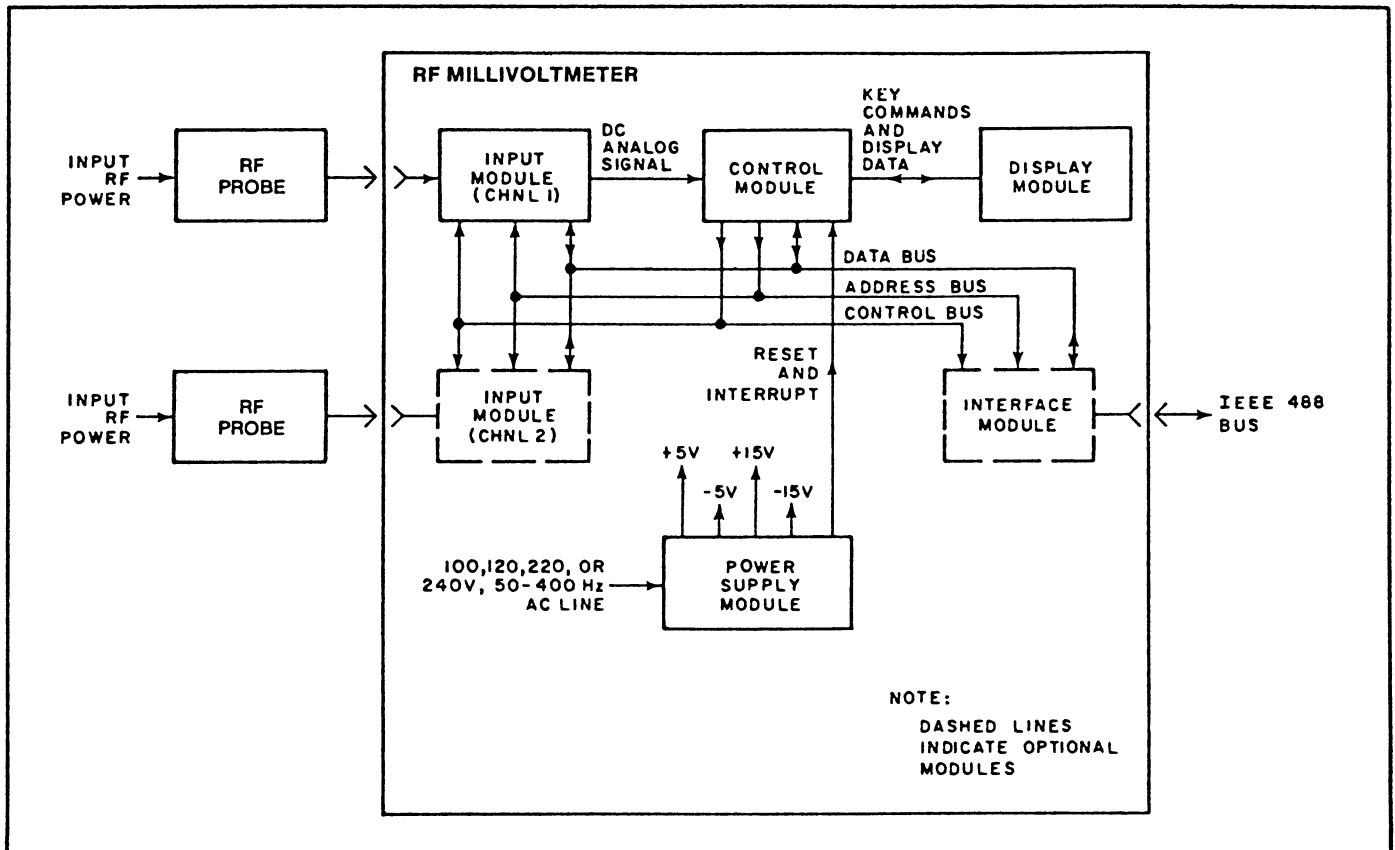

Figure 3-1 Overall Block Diagram

3-15. DETAILED THEORY OF OPERATION, INPUT P.C. BOARD CIRCUITS.

(See Figure 3-2)

3-16. The input printed circuit board receives from the probe a dc voltage that is a function of the RF voltage level being measured. Under control of the control board circuits, it provides amplification and signal processing required to develop an analog dc voltage and a digital signal that are both proportional to the input RF voltage level. The input dc voltage from the probe is balanced in form, and may vary from microvolts to volts, depending upon the input RF voltage level. The input printed circuit board must provide amplification with a wide range of gain, low offset voltage, and low noise; therefore, the input dc voltage is converted to an ac voltage which is amplified, and the amplified ac voltage is converted to a dc analog signal and to a digital signal.

3-17. The input dc voltage is converted to an ac voltage by a chopper module, which plugs in to the input printed circuit board. The chopper is composed of solid-state switches IC1a through IC1d in a balanced arrangement, operating at a frequency of approximately 94 Hz to minimize ac line and line-related component interaction. The chopper drive signal is derived from the output of an astable multivibrator, which is completely independent of line frequency. The use of a solid-state chopper eliminates many of the problems, such as contact wear and contamination, associated with electromechanical choppers. The chopper supplies a balanced ac signal of approximately 94 Hz to the input amplifier.

3-18. Amplification of the balanced 94 Hz ac signal from the chopper is accomplished by an input amplifier composed of low-noise operational amplifiers A5, A6, and A7. A balanced arrangement with degenerative feedback for stabilization and gain control is employed. The input ac signal is amplified by 500, 50, 5, or 0.5, depending upon the instrument range. Demultiplexer IC6, under control of the control printed circuit board, adjusts the degenerative feedback in accordance with the range selected by the microprocessor to provide the required gain switching. An attenuator at the output of the input amplifier provides attenuation of 5 for the highest range only; on all other ranges its attenuation is 1. This attenuator is switched into the circuit on the highest range through solid-state switches IC10a, IC9b, and IC9c. Demultiplexer IC13 decodes digital signals that define the range and activates the solid-state switches on the highest instrument range.

3-19. The amplified 94 Hz signal is converted to a dc analog signal by means of a demodulator circuit that operates in synchronism with the chopper. The demodulator consists essentially of a sample-and-hold switch, composed

of solid-state switches IC10b and IC10c and associated circuitry. Switches IC10b and IC10c are controlled by the 94 Hz drive signals from flip-flops IC8a and IC8b. The sampling point and period of the sample-and-hold circuit have been chosen to minimize switching products and noise, and to vary signal averaging in accordance with the signal level. Switch IC9a adjusts operating parameters automatically in accordance with the instrument range; it is activated through gates IC11b and IC11c and demultiplexer IC13 on the four higher ranges.

3-20. The dc output voltage of the sample-and-hold circuit is amplified by integrated circuits A8, IC14, A9, and associated circuitry. Integrated circuit IC14 is a demultiplexer that decodes microprocessor-supplied digital signals that define the selected range and adjusts an attenuator circuit accordingly; the gain of the amplifier is 125, 12.5, or 1.25, depending upon the selected range. The full-scale output voltage of the amplifier is 2.5 volts nominal on each range.

3-21. The output voltage of integrated circuit A9 is usually unipolar and positive; however, during automatic zeroing, it may be positive or negative, depending upon small dc offsets. Because some of the following circuits operate only with unipolar signals, a polarity switch is required. This polarity switch, which consists of solid-state switches IC3b and IC3c, operates under control of the microprocessor on the control printed circuit board, which tests for polarity. The dc voltage is routed through the polarity switch to the appropriate input of operational amplifier A3 so that the dc output from this amplifier is always negative. This negative output voltage is applied to a comparator circuit.

3-22. Comparator A2 operates in conjunction with the microprocessor on the control printed circuit board and D/A converter IC2 to convert the dc output signal of amplifier A3, which is proportional to the input RF voltage, to a digital signal that can be processed by the microprocessor. D/A converter IC2 is supplied with successive half-level digital signals (full-scale/2, full-scale/4, etc.) by the microprocessor. D/A converter IC2 converts these digital signals to a dc analog voltage that is supplied through amplifier A1 to comparator A2, where it is compared with the dc signal from amplifier A3. The difference signal from comparator A2 is supplied to the microprocessor through interface IC1 so that the microprocessor can monitor the results of the comparison and adjust the digital signal accordingly. The digital signal is adjusted by the microprocessor until the two input signals applied to comparator A2 are equal. The resulting digital signal then defines the dc level being measured. This digital signal is then processed (zero correction, unit conversion, etc.) by the microprocessor before application to the LED display circuits of the instrument.

Section III Theory of Operation

3-23. After the digital signal has been fully processed by the microprocessor, it is supplied by the microprocessor to D/A converter IC2, which now converts the processed digital signal to a corresponding dc analog voltage that is used to drive the front-panel meter and the recorder output of the instrument. This dc analog voltage from D/A converter IC2 is supplied through amplifier A1 to sample-and-hold switch IC3a, which is closed at this time by a control signal from the microprocessor. The analog dc voltage from the sample-and-hold circuit is applied to the front-panel meter and the recorder output.

3-24. All interfacing between the input printed circuit board and the microprocessor is accomplished through interface IC1, an input/output device that operates under control of the microprocessor. When signal \overline{RD} is activated by the microprocessor, data is transferred from the input printed circuit board to the microprocessor, provided that signal \overline{CS} to interface IC1 is also active; when signals \overline{WR} and \overline{CS} are both activated by the microprocessor, data is transferred from the microprocessor to the input printed circuit board. Data flows between the input printed circuit board and the microprocessor over the eight-line bi-directional data bus. Routing of data through the interface is controlled by the address signals supplied to the interface by the microprocessor.

3-25. DETAILED THEORY OF OPERATION, CONTROL P.C. BOARD CIRCUITS. (See Figure 3-3.)

3-26. Operation of the instrument is controlled by a microprocessor on the control printed circuit board. The control printed circuit board is organized around a central processing unit (CPU), associated memories, input/output ports, and a 40-line bus. A stored program, in conjunction with key-entered commands, enables the microprocessor to perform a variety of functions, including the following:

- a. Analog to digital conversion
- b. Zero determination
- c. Zero correction
- d. Ranging
- e. Signal processing
- f. Binary to BCD conversion
- g. dB conversion
- h. dB reference conversion
- i. dB limit testing

3-27. Integrated circuit IC3 is the microprocessor CPU. It is an 8-bit unit that operates at a clock frequency of 2 MHz, generated by integrated circuits IC1a through IC1c and associated circuitry. The operating program for the microprocessor is stored in integrated circuits IC6 and IC7, which are programmable read-only memories (PROMs).

Integrated circuits IC8 and IC10 provide 1000 bytes of static RAM for use by the CPU for temporary storage of data during operation of the instrument. Integrated circuits IC11 and IC12 are used to store certain measurement parameters such as, probe data, key-entered parameters, etc. Lithium-type cells BT1 and BT2, which have an anticipated life of 10 years, supply power to integrated circuits IC11 and IC12 during power-down of the instrument to enable retention of data stored in these memories; during normal operation, these memories are powered by transistor Q1. Integrated circuit IC16 is an I/O port which interfaces the following:

- a. An 8-bit switch used to set the mode of operation, number of channels, and number of probes.
- b. A test socket (J3) used in signature analysis.
- c. A connector (P3) for output of status information.

3-28. The CPU receives and transmits data over an 8-line data bus. A 15-line bus is used for addressing, and a control bus is used for various control functions. When the instrument is turned off, signal \overline{RESET} is activated by the power supply circuits and the microprocessor is reset to the start of the operating program; when the instrument is next turned on and dc voltages have reached the correct operating levels, the \overline{RESET} signal is deactivated by the power supply circuits and the microprocessor begins to execute the stored program instructions. Instructions are retrieved from storage by the CPU in accordance with the address code developed at its output. Decoder IC4 enables the appropriate PROM (IC6 or IC7), and the instruction contained in the memory location defined by the address on address lines A0 through A11 is read and transmitted to the CPU over the data bus. The CPU then executes this instruction.

3-29. During the measurement process, the CPU must retrieve data from storage and from the input and display printed circuit boards; it must store temporary calculation values; and it must output data to the input and display printed circuit boards. To retrieve data from memory, the storage device and data location are defined by the address supplied by the CPU. Integrated circuit IC4 decodes three of the address bits to develop an enabling signal for the appropriate memory device. The other address bits define the location in storage of the data to be retrieved, and the data stored at this location is transmitted over the data bus to the CPU or to other circuits connected to the data bus. To access data developed by circuits outside the control printed circuit board, the CPU activates signals \overline{TORQ} and \overline{RD} along with the appropriate address lines. Decoder IC14 decodes three address bits to develop enabling signal \overline{CS} for interface IC16, integrated circuit IC18, or interface IC1 on

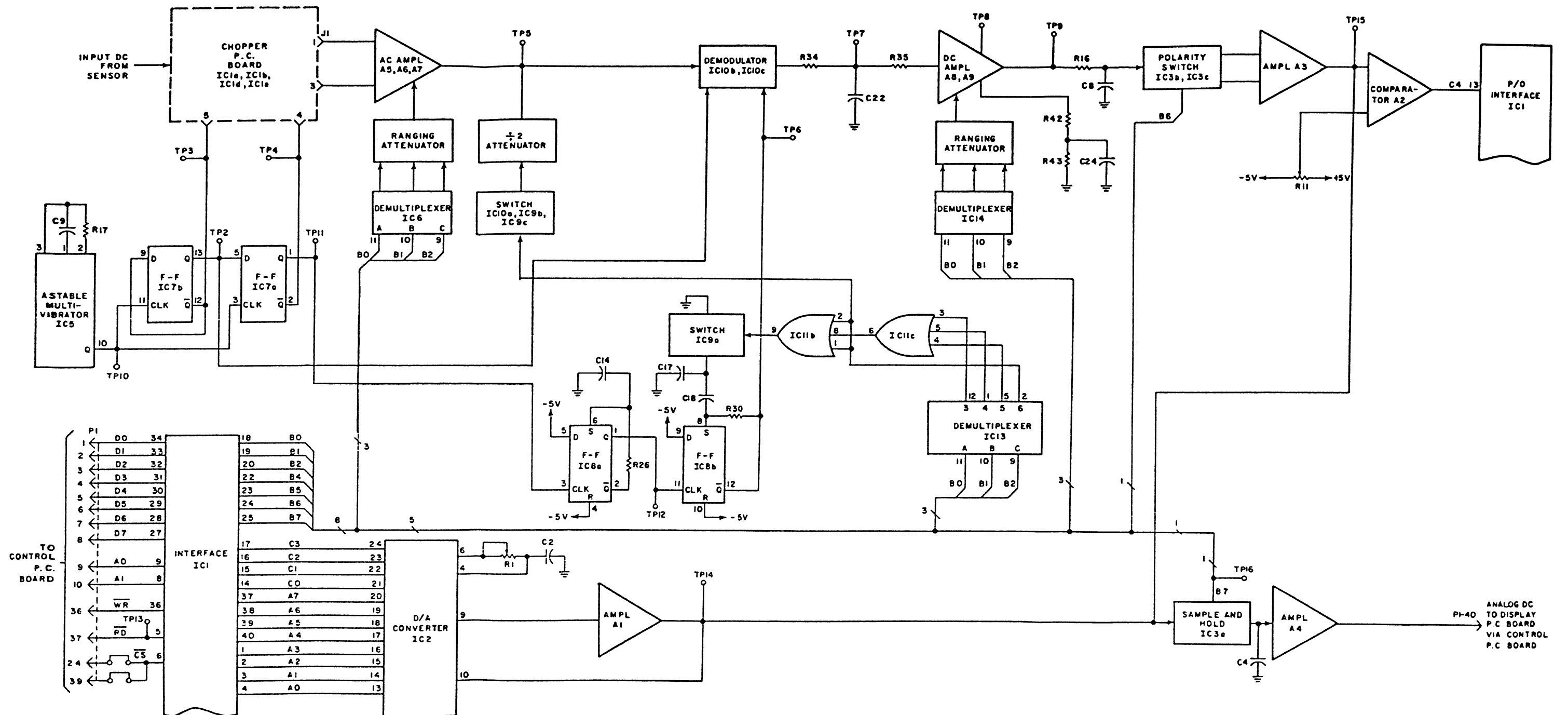

Figure 3-2 Input P.C. Board, Detailed Block Diagram

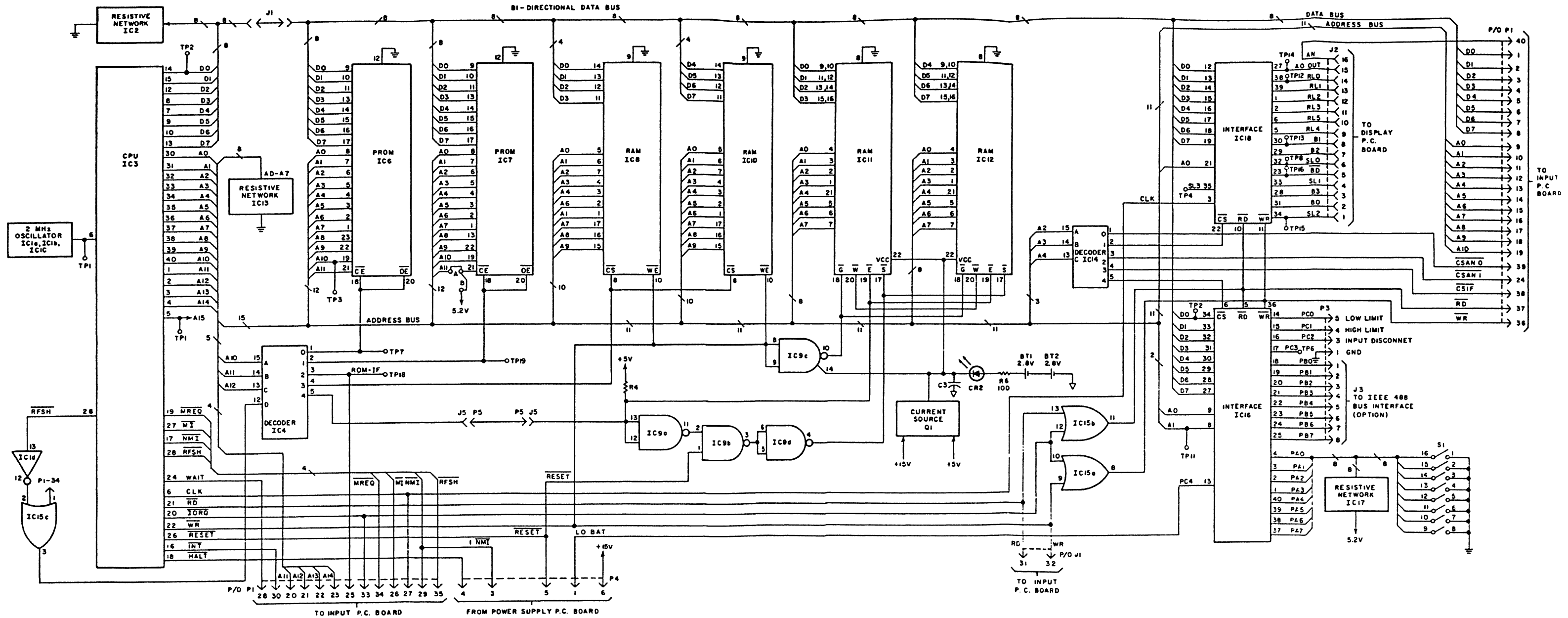

Figure 3-3 Control P.C. Board, Detailed Block Diagram

the input printed circuit board, as specified by the three address bits; and gate IC15b activates signal \overline{RD} for the read function. If integrated circuit IC18 is enabled, keyed-in commands from the display circuit board, which had been stored in integrated circuit IC18, are transmitted over the data bus. If integrated circuit IC16 is enabled, input data from connector J3, bit switch S1, or power supply connector P4, as determined by address bits A0 and A1, is supplied through interface IC16 to the data bus. If interface IC1 on the input printed circuit board is enabled, data generated on the input printed circuit board is transmitted over the data bus through interface IC1.

3-30. To write data into memory, the CPU activates signal \overline{WR} and the address lines that define the storage device and storage location. Decoder IC4 decodes three bits of address to enable the appropriate storage device; signal \overline{WR} enables the write function of the selected device; and data on the data bus is written into memory at the location specified by the remaining address lines. To output data to circuits outside the control printed circuit board, signal \overline{TORQ} is activated by the CPU in addition to the previously mentioned signals. Signals \overline{TORQ} and \overline{WR} activate the write enable signal to the device defined by the address bits. Decoder IC14 decodes three address bits to select the appropriate device (interface IC16, interface IC18, or interface IC1 on the input printed circuit board). Data on the data bus is then transferred to the selected device. If interface IC16 is selected, this data is transferred through interface IC16 to connector P3 or J3, as determined by address bits A0 and A1. The output to connector P3 consists of dB out-of-limit signals and an input-disconnect signal, which is activated when the automatic zeroing function is initiated. The output data on connector J3 is used in signature analysis checks. If interface IC18 is selected, the data on the data bus are written into storage in interface IC18 for application to the display printed circuit board. These data are subsequently clocked out of storage to activate the LED display and annunciators on the display printed circuit board. If interface IC1 on the input printed circuit board is selected, data on the data bus are transferred through the interface to control various functions on the input printed circuit board.

3-31. Connector J1 is included in the data bus on the control printed circuit board to facilitate signature analysis checks of the microprocessor circuits. When connector J1 is pulled out, the data bus is disconnected from the CPU, and the CPU executes successive NOPs for free-running signature analysis checks.

3-32. The CPU receives two control signals directly from the power supply printed circuit board. If the power supply voltage should drop during operation, or on equipment turn-off, signal \overline{NMI} is activated by the power supply cir-

cuits; the CPU, on receipt of this signal, activates signal \overline{HALT} , thereby halting further execution of the program. Signal \overline{HALT} is applied back to the power supply printed circuit board, where it latches signal \overline{RESET} in the active state. Signal \overline{RESET} , in turn, causes the microprocessor to return to the starting point of the program. When the power supply voltage rises to a level approximately 150 millivolts below its nominal value, either as a result of correction of the undervoltage condition or of power turn-on, signal \overline{RESET} is deactivated to permit execution of the stored program by the microprocessor.

3-33. DETAILED THEORY OF OPERATION, DISPLAY P.C. BOARD CIRCUITS. (See Figure 3-4.)

3-34 The display printed circuit board contains the instrument LED display, analog meter, annunciators, keyboard, and control circuits for these items. It interfaces directly with the control printed circuit board. When any keyboard key is pressed, the microprocessor on the control printed circuit board interrupts the normal measurement process and accepts and stores the key-entered commands; the microprocessor also supplies digital data to the display printed circuit board to cause keyed-in numerical values to appear on the LED display. The microprocessor resumes the normal measurement process when any of the terminator keys (LIMITS dB, SELECT, dB REF LEVEL) is pressed. Upon completion of the measurement by the microprocessor, measurement values are supplied to the display printed circuit board.

3-35. Operation of the display printed circuit board is controlled by the microprocessor through integrated circuit IC18 on the control printed circuit board, which provides the following functions:

- a. It provides a RAM for storage of microprocessor output data to the display printed circuit board.
- b. It provides a first-in, first-out RAM which accepts and stores input information (up to 8 key commands) from the display printed circuit board.
- c. It provides scan signals for both the LED display and the keyboard.

3-36. The LED display consists of four 7-segment displays, which provide a display capacity of four digits with decimal points, and a fifth display which is capable of displaying a minus sign. Each display consists of individual anodes for each segment that makes up the display and the decimal point, and a common cathode. The character that appears on the display is determined by the activated anodes at the time that the common cathode is scanned. The individual

Section III Theory of Operation

displays and the associated annunciators are scanned in sequence. The display duty cycle is 12.5%; that is, each digit or annunciator of the instrument is on 12.5% of the time.

3-37. Digital information for the LED display and annunciators is developed by the microprocessor and is stored in the output RAM contained in integrated circuit IC18 on the control printed circuit board. Digital information that defines display and annunciator row selection is supplied to 8-channel demultiplexer IC2. The output lines of demultiplexer IC2 are activated in sequence, based on the input digital codes. The signal on the active output line of demultiplexer IC2 is applied through resistive network IC5 to display driver IC7, and the display driver supplies driving power for the corresponding display and the corresponding annunciator row. At the same time, digital data that define the display segments and annunciators that are to be activated are supplied to decoder IC1. The binary-coded input is decoded by decoder IC1, and the output lines of the decoder are activated in accordance with this decode. The outputs of the decoder activate the individual anodes of the selected display and the individual annunciators in the active annunciator row, thereby providing the appropriate instrument display. A decimal-point signal is applied through transistor Q1, when appropriate, to cause a decimal point to be displayed to the right of the character on the active display.

3-38. Demultiplexer IC2 also supplies scanning signals to the keyboard. As each of its first five output lines is activated in sequence, a scan signal is applied to an individual row of the keyboard through an inverter. If any key in the row being scanned is pressed, a signal is supplied to one of the column output lines to the RAM in integrated circuit IC18 on the control printed circuit board, and the key command is stored in the RAM. Key selection is defined by a combination of the row scan signal and the column output line. The RAM can store up to a maximum of eight key commands, and it delivers this stored information to the microprocessor when it is read. Actuation of more than eight key commands without a read causes the RAM to be cleared.

3-39. Analog dc voltage proportional to the measured RF voltage level is supplied from the control printed circuit board to the front-panel meter to provide a relative indication of measured RF voltage for peaking and nulling applications. The dc analog voltage is also supplied to rear-panel connector P1. This signal can be used to drive an external recorder.

3-40. DETAILED THEORY OF OPERATION, POWER SUPPLY CIRCUITS. (See Figure 3-5.)

3-41. Power supply printed circuit board A7 performs the following functions:

- a. Converts 100, 120, 220, or 240 volt, 50 to 400 Hz, ac line power to +5, +5.2, -5, +15, and -15 volt dc for system operation.
- b. Generates a power-up signal for the microprocessor when supply voltage levels reach the proper values for system operation.
- c. Activates an interrupt signal to the microprocessor when supply voltage levels drop to values too low for reliable operation.

3-42. Input ac line power is supplied to the primary of power transformer T1 on the main chassis through fuse F1, LINE switch S1, and a voltage-selector printed circuit card. The voltage-selector printed circuit card provides a convenient way to change the primary winding connections of power transformer T1 to accommodate the various ac line voltages.

3-43. Power transformer T1 steps down the ac line voltage. Two separate secondary windings drive bridge rectifiers CR1 and CR2. The dc output voltage of rectifier CR1 is filtered by capacitors C1 and C2, and is then supplied to regulators IC2 and IC3, which develop +15 volts and -15 volts dc, respectively. A regulated -5 volt output is derived from the regulated -15 volt supply by regulator IC5. The dc voltage developed by rectifier CR2 is filtered by capacitor C3 and drives regulator IC4 to develop the +5.2 volt dc output. Potentiometer R5 provides means for adjusting the +5.2 volt output.

3-44. The raw +15 volt dc supply also drives regulator IC1, which produces +5 volts to power integrated circuits A1 and IC6 and generate a dc reference voltage at the junction of resistors R7 and R8. Comparator A1a monitors the output voltage of the +5.2-volts regulated supply to develop a power-up signal on turn-on and an interrupt signal for undervoltage or power-down conditions. When the instrument is turned on, comparator A1a develops a positive output pulse when the output voltage of the +5.2-volts regulated supply reaches a level approximately 150 millivolts below the nominal output voltage. This positive pulse clocks flip-flop IC6 to deactivate signal $\overline{\text{RESET}}$ to the microprocessor on the control printed circuit board. When the output voltage of the +5.2-volts regulated supply drops below the reliable usable level during instrument operation or during instrument shutdown, comparator A1a switches its output level to a logic low, thereby activating signal $\overline{\text{NMI}}$ to the microprocessor. The microprocessor then activates signal $\overline{\text{HALT}}$, which resets flip-flop IC6, thereby latching signal $\overline{\text{RESET}}$ low to ensure resetting of the microprocessor to the start of its program.

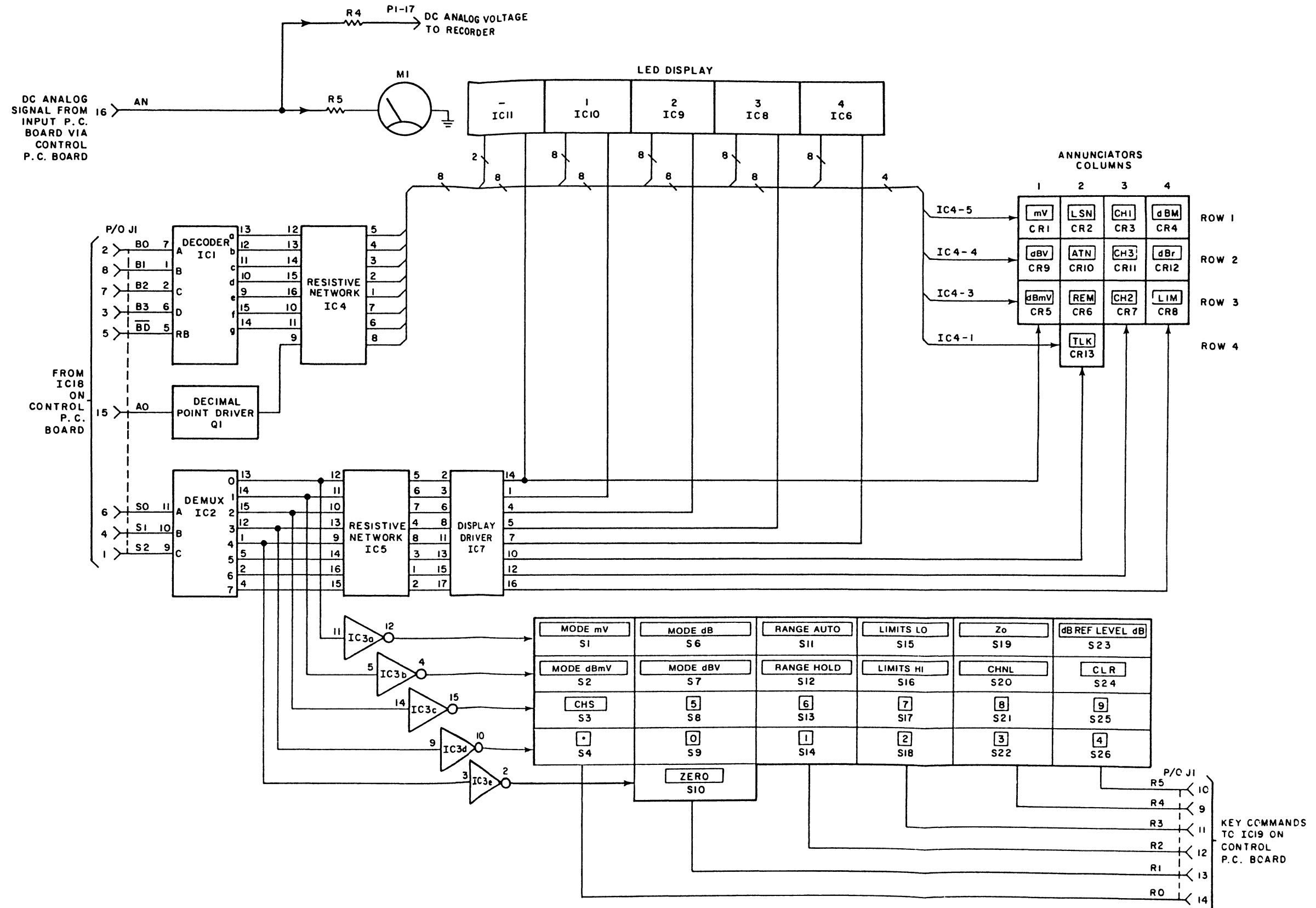

Figure 3-4 Display P.C. Board, Detailed Block Diagram

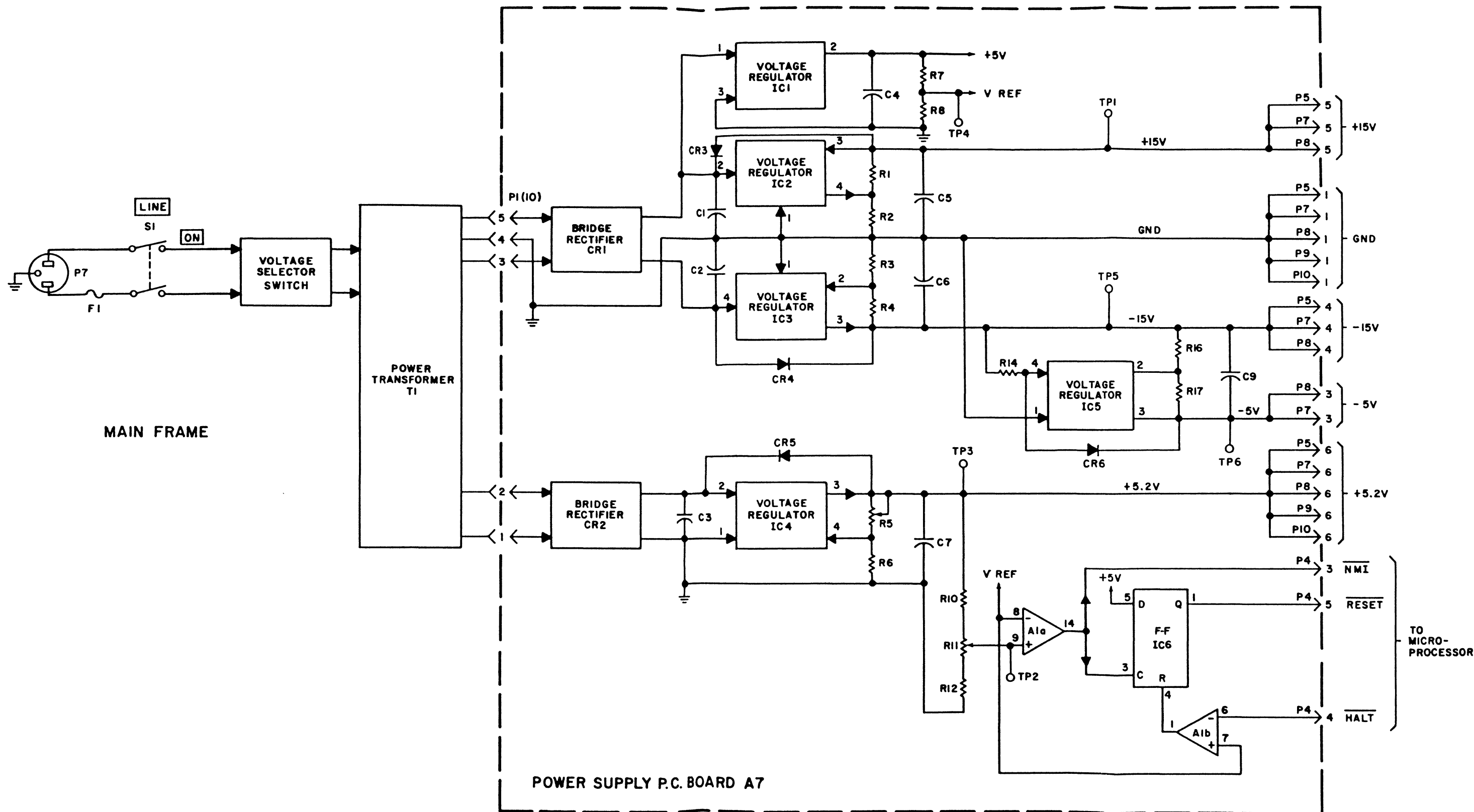

Figure 3-5 Power Supply P.C. Board, Detailed Block Diagram

SECTION IV MAINTENANCE

4-1. GENERAL

4-2. This section contains maintenance instructions for the instrument. Included are a list of required test equipment, trouble localization procedures, instrument adjustment procedures, and probe calibration procedures. Minimum performance checks are included in Section II; these checks should be performed whenever there is any doubt about instrument performance.

4-3. TEST EQUIPMENT REQUIRED.

4-4. Table 4-1 lists test equipment required for maintenance of the instrument. Test equipment of equal capability may be substituted for any listed item except the Model 5004A signature analyzer, unless it is known that the substitute signature analyzer agrees completely with the Model 5004A and the Model 2500 Range Calibrator.

4-5. TROUBLESHOOTING CONCEPT.

4-6. The instrument employs both analog and digital circuitry. The digital portion uses a microprocessor in a bus-oriented system. Dc and ac measuring instruments such as voltmeters and oscilloscopes have been the traditional test instruments for electronic instrument maintenance; however, in a microprocessor-based, bus-oriented system, such test equipment, while still useful and necessary, leaves much to be desired. With such test equipment alone, troubleshooting in a bus-oriented system is extremely tedious and time-consuming, if not impossible. A technique called signature analysis has been devised to deal with microprocessor-based systems. The troubleshooting procedures in this section are based on signature analysis techniques.

4-7. SIGNATURE ANALYSIS.

4-8. A complete discussion of signature analysis is beyond the scope of this manual; however, a brief discussion will aid in maintenance of the instrument. Long, complex data streams are present in microprocessor-based, bus-oriented systems. In signature analysis, with the system operating at normal speed, these data streams are compressed into concise, easy-to-interpret readouts (signatures) measured at pertinent nodes. By choosing or generating appropriate measuring periods or windows, these signatures become unique; one and only one signature occurs at each node if operation is normal. Using signature analysis, it is possible

TABLE 4-1. TEST EQUIPMENT LIST

Nomenclature	Model
Digital Multimeter	Data Precision 1450
Oscilloscope	Hewlett-Packard 1740A
RF Millivoltmeter Calibrator	Boonton Electronics 26A
Signature Analyzer	Hewlett-Packard 5004A
Diagnostic ROM	Boonton Electronics P/N 961003
Range Calibrator	Boonton Electronics 2500
NOTE	
The following additional items are required only for RF probe SWR and frequency response checks.	
Signal Generator:	
125 kHz to 175 MHz	Boonton Electronics 103C or 103D
450 kHz to 520 MHz	Boonton Electronics 102E or 102F
10 MHz to 1400 MHz	Wavetek Model 2001
Slotted Line Detector	General Radio 900 LB General Radio 1241 or Boonton Electronics 9200
Power Splitter	Weinschel Model 1870A or Hewlett-Packard 11850A
Calibrated RF Microwattmeter	Boonton Electronics 4200
Sweep Generator	Wavetek 2001
SWR Autotester	Wiltron 63N50
Oscilloscope	Tektronix 5100 (with two 5A20 vertical amplifiers)
Standard 1.2:1 Mismatch Termination	Weinschel M1410-1.2

Section IV Maintenance

to proceed through the instrument in an orderly fashion until a faulty signature is obtained. Generally, at that point, it is possible to identify one component as the most probable cause of the malfunction. In this instrument, all integrated circuits and transistors are socket-mounted to enable removal and replacement without the need for unsoldering and soldering.

4-9. Signature analysis checks are of two basic types: "free running" and "stimulated" or programmed. In free-running checks, the data bus between the microprocessor and the system is opened, and an instruction that will cause the microprocessor to free-run is forced. The microprocessor then runs through its address field repeatedly. Free-running checks may be used to check the following:

- a. Microprocessor address output
- b. Memory select decoding
- c. I/O select decoding
- d. ROM program

4-10. In the stimulated mode, the data bus between the microprocessor and the system bus is left intact, and programs provided in a special ROM are invoked to conduct the desired tests. In this instrument, the stimulated mode is used to check the following:

- a. RAM operation
- b. Display functions and scanning
- c. Keyboard
- d. I/O ports

4-11. In this instrument, programmed signature analysis tests are activated by setting a bit switch, located at the rear of the control printed circuit board, to the number associated with the particular test. In using signature analysis, free-running tests should be performed first to ascertain that the microprocessor is putting out a normal address field, that the memory and I/O decoding is correct, and that the ROM contents are normal. When correct signatures have been obtained for all free-running tests, the programmed tests may be performed.

4-12. The signature analysis technique is applicable only to the digital section of the instrument. Some sections of the instrument employ both analog and digital circuits. The input module, for example, receives a dc analog signal, amplifies the analog signal, and converts it to a digital signal; the power supply uses both digital and analog circuitry

to develop the voltages necessary for instrument operation. The discussion of these hybrid sections in Section III of this manual will be helpful in maintenance and servicing.

4-13. TROUBLE LOCALIZATION.

4-14. Gaining Access to Internal Components. To gain access to internal components of the instrument for maintenance or adjustment, remove the top and bottom covers by removing the securing screw at the rear of each cover and then sliding the cover to the rear. Figure 4-1 shows the location of major assemblies. To gain access to these assemblies, proceed as follows:

a. **Input Module.** To gain access to parts on the input module, remove four screws (one in each corner) and lift off the cover.

b. **Display Module.** To gain access to the display module, pry off the two black plastic side trim strips, remove the four screws that attach the front top and bottom trim strips, and remove the top and bottom trim strips and the front panel.

4-15. Visual Inspection. With the instrument covers removed, inspect all assemblies for foreign material, unseated integrated circuits, transistors, or connectors, for broken leads, scorched components, loose screws, and any other evidence of electrical or mechanical malfunction.

4-16. Use of Block Diagrams. By studying the detailed theory of operation in Section III together with the associated block diagrams, it may be possible to isolate the cause of an instrument malfunction to a particular block.

4-17. Systematic Troubleshooting. If visual inspection and block diagram analysis do not localize the source of an instrument malfunction, proceed with module troubleshooting as follows:

a. **Power Supply.** With normal input power applied to the instrument, check the power supply output voltages at each module power connector. Correct power supply voltages are shown on the applicable schematic diagrams. If an abnormal voltage is encountered, disconnect the module connector from the module and note whether the power supply output voltage becomes normal; if it does, the problem is probably not in the power supply but in the disconnected module. If, on the other hand, the abnormal voltage condition remains, work backward through the power supply circuits, comparing voltages with those shown on the power supply printed circuit board schematic diagram (Figure 6-6). By analyzing abnormal indications, it should be possible to localize the problem to one or more components in the power supply.

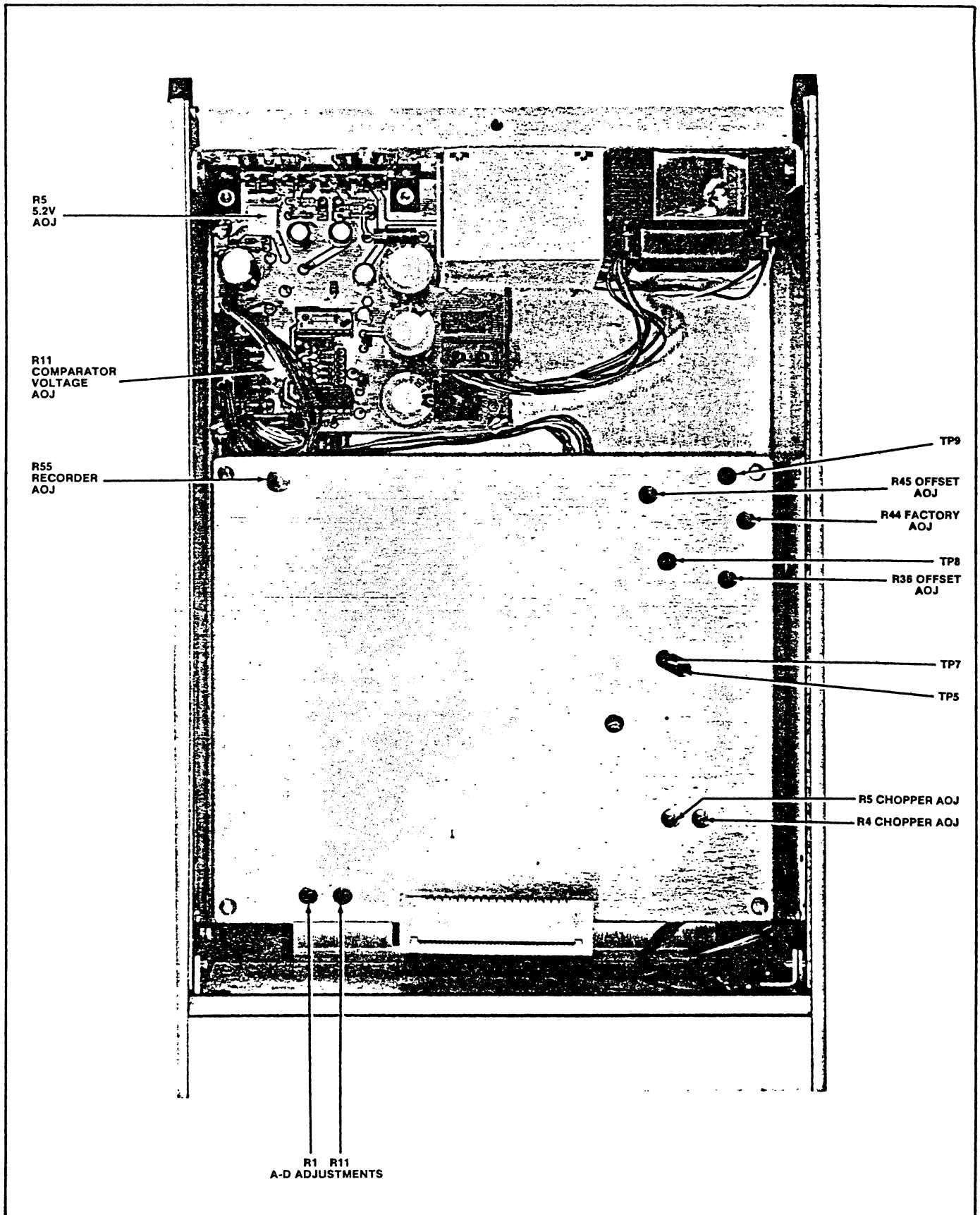

Figure 4-1 Location of Major Assemblies (Sheet 1 of 2)

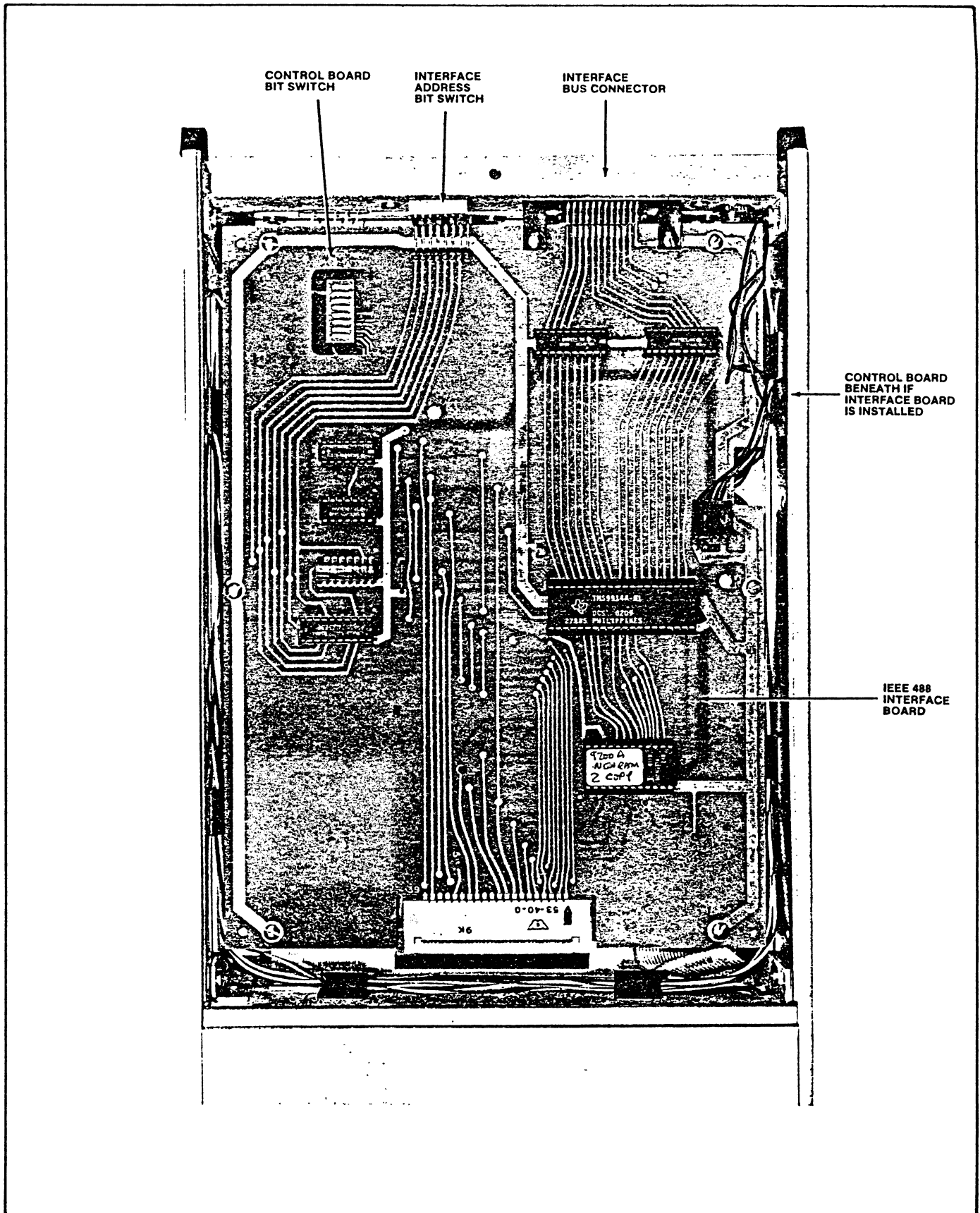

Figure 4-1 Location of Major Assemblies (Sheet 2 of 2)

b. **Input Module.** With a 700 mV signal applied to the probe, compare waveforms and voltages with those shown in Figure 4-2. Correct indications will essentially eliminate the input module as the source of an instrument malfunction; however, incorrect indications will not necessarily localize the problem to the input module because the input module depends on proper operation of the control module for such functions as ranging, analog-to-digital conversion, and recorder and meter output. If incorrect indications are obtained, localization of the problem using an oscilloscope and digital voltmeter may be a long and tedious process; a simpler approach may be to proceed with signature analysis.

c. **Display Module.** Proper operation of the display module is generally self-evident. Incorrect operation does not necessarily mean that the problem is in the display module; the control module may be malfunctioning. The simplest and quickest way to check the display module is by performing the visual and signature analysis checks specified in paragraph 4-20.

d. **Control Module.** If normal indications are obtained in checking the power supply, input, and display modules of a malfunctioning instrument, the problem must be in the control module; however, it is very unlikely that this situation will occur because it is virtually impossible for the input and display modules to operate properly if the control module is malfunctioning. Signature analysis is the best way to localize a problem in the control module.

4-18. SIGNATURE ANALYSIS FREE-RUNNING TEST PROCEDURES.

4-19. To make free-running signature analysis tests, proceed as follows:

CAUTION

Make certain that power is off before attempting to perform steps a, b, and f of the following procedure. Failure to observe this caution may result in the loss or destruction of data stored in the non-volatile RAM.

NOTE

Prior to any signature analysis checks, note and record the settings of bit switch (Figure 4-3). Restore these switch settings upon completion of the signature analysis checks.

a. **With power off**, remove the data bus connector P1 on the control printed circuit board from socket J1, and disconnect jumper from connector J5. (See Figure 6-4.) Do not remove any of the control printed circuit board PROMs.

b. Refer to Tables 4-2 through 4-7 for detailed information for the free-running tests. For each test, set the signature analyzer controls and make signature analyzer connections as specified in the applicable table.

NOTE

For instruments containing PROMS with codes differing from those referred to in the various signature analysis tables contact the Boonton Service Dept. for correct signatures.

c. After setting and connecting the signature analyzer, apply power to the instrument. Touch the signature analyzer probe to the specified measurement points, and compare the signatures obtained with those specified in the table. An incorrect signature is evidence of malfunction.

d. If an incorrect signature is noted, try replacing the integrated circuit(s) most intimately associated with the point at which the incorrect signature was obtained. For example, an incorrect signature in the address field would point to integrated circuit IC3 on the control printed circuit board, but the problem could be caused by any other integrated circuit or component tied to that address line.

e. A signature of 0000 is obtained with the signature analyzer probe connected to common (ground). Some other items that will produce this signature are:

1. A node stuck at logic 0.
2. A node at the signature analyzer clock frequency.

f. A signature of 755U or 7A70 is obtained with the signature analyzer probe connected to +5 volts. Some other items that will produce the same signatures are:

1. A node stuck at logic 1.
2. Any signal with a specific relationship to the clock signal. If the clock signal is signal RD from the microprocessor, signals IORQ, WR, and RFSH are examples of signals that will produce these signatures.

g. Upon completion of the free-running checks, *turn power off*. Then, reinstall data bus connector P1 in socket J1 on the control pcb and reinstall jumper at connector J5.

NOTE

If programmed signature analysis tests are to be performed, leave jumper disconnected from connector J5.

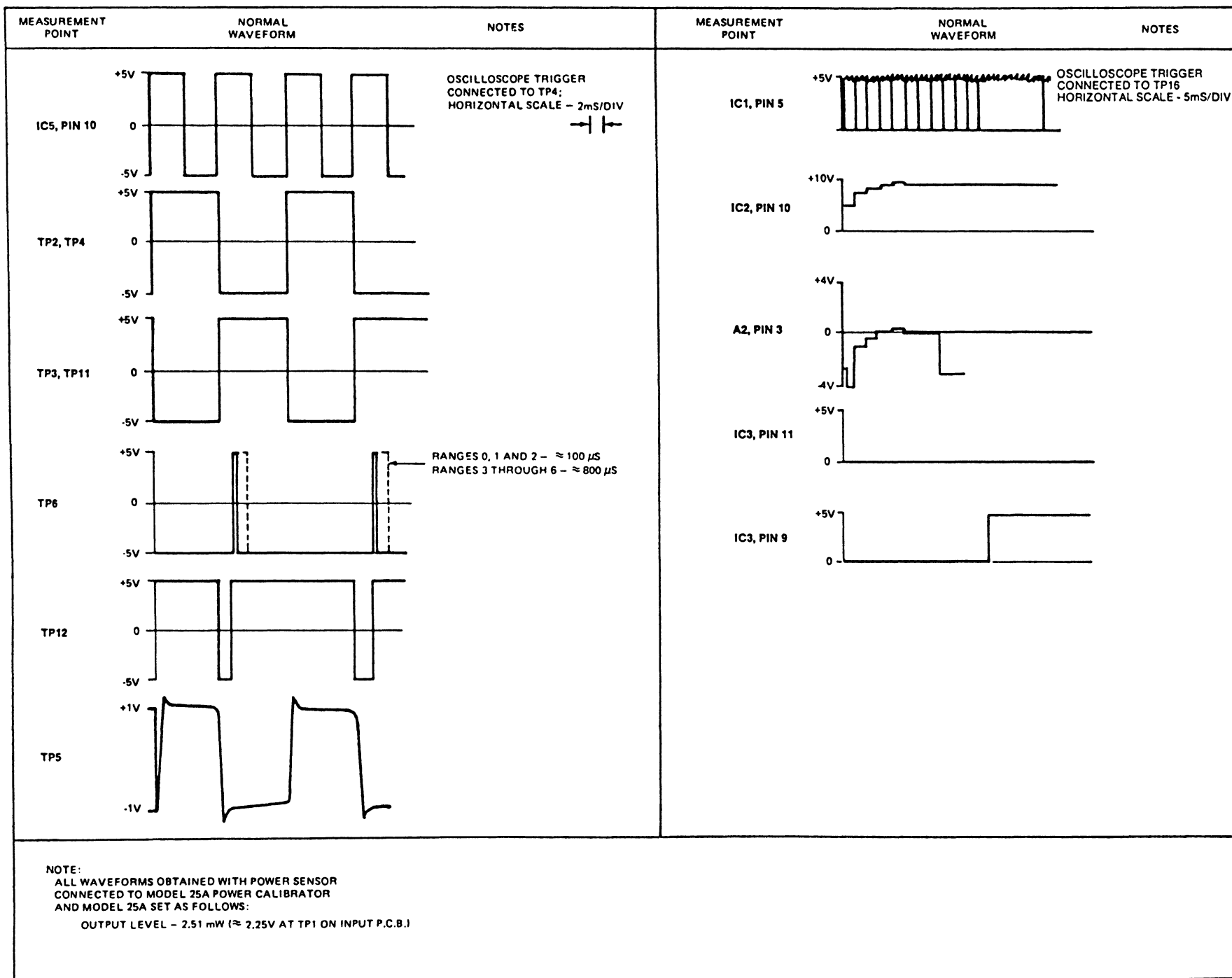
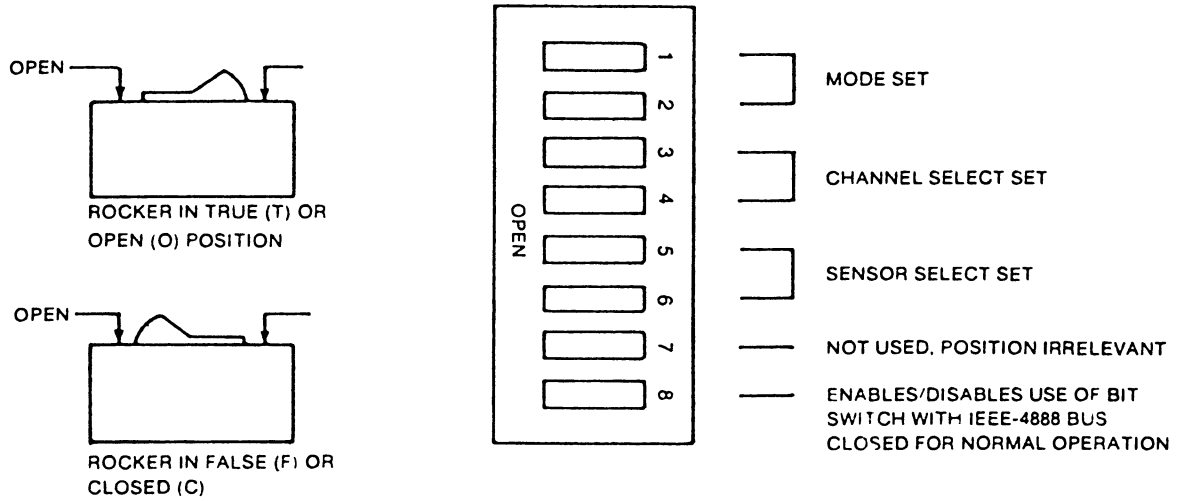

Figure 4-2 Input P.C. Board, Voltage and Waveform Data



SWITCH SETTING								COMMENT
8	7	6	5	4	3	2	1	
A	N							
L	O					C	C	OPERATE MODE
W	T					C	O	CALIBRATE MODE 1 (DC CAL.)
A	U					O	C	CALIBRATE MODE 2 (AC CAL.)
Y	S			C	O			ONE CHANNEL OPERATION
S	E			O	O			TWO CHANNEL OPERATION
C	L	C	C					ONE SENSOR CAPABILITY
L	O	C	O					TWO SENSOR CAPABILITY
S	E	O	C					THREE SENSOR CAPABILITY
D		O	O					FOUR SENSOR CAPABILITY

THE ACTUAL SWITCH SETTING WILL BE A COMBINATION OF THE ABOVE.

Figure 4-3 Control P.C. Board Bit Switch Settings

TABLE 4-2. CONTROL BOARD ADDRESS FIELD TEST*

Signature Analyzer			Bit Switch**								Measurement		
Function	Switch Setting	Connection Point	1	2	3	4	5	6	7	8	Item	Point	Signature
START	┌ ├ └	TP1	Any setting									Common	0000
STOP		TP1										+5V	755U
CLK		TP5									A0	IC3, pin 30	H335
		A1									IC3, pin 31	C113	
		A2									IC3, pin 32	7050	
		A3									IC3, pin 33	0772	
		A4									IC3, pin 34	C4C3	
		A5									IC3, pin 35	AA08	
		A6									IC3, pin 36	7211	
		A7									IC3, pin 37	A3C1	
		A8									IC3, pin 38	7707	
		A9									IC3, pin 39	577A	
		A10									IC3, pin 40	HH86	
		A11									IC3, pin 1	89F1	
		A12									IC3, pin 2	AC99	
		A13									IC3, pin 3	PCF3	
		A14									IC3, pin 4	1180	
		A15	IC3, pin 5	755U									

*This test checks the output of the proper address field by CPU IC3; however, any item connected to an address line could be responsible for an incorrect signature on that line.

**O = open

TABLE 4-3. CONTROL BOARD MEMORY DECODING TEST*

Signature Analyzer			Bit Switch**								Measurement		
Function	Switch Setting	Connection Point	1	2	3	4	5	6	7	8	Item	Point	Signature
START	┌ ├ └	TP1	Any setting									Common	0000
STOP		TP1										+5V	755U
CLK		TP5									$\overline{CS0}$	IC4, pin 1	FU4U
		$\overline{CS1}$									IC4, pin 2	A207	
		$\overline{CS2}$									IC4, pin 3	H6A3	
		$\overline{CS3}$									IC4, pin 4	HU34	
		$\overline{CS4}$									IC4, pin 5	H24U	

*This test checks decoding for selection of memory integrated circuits.

**O = open

TABLE 4-4. CONTROL BOARD I/O DECODING TEST*

Signature Analyzer			Bit Switch**								Measurement			
Function	Switch Setting	Connection Point	1	2	3	4	5	6	7	8	Item	Point	Signature	
START	}	TP1	Any setting									Common	0000	
STOP		TP1										+5V	755U	
CLK		TP5										$\overline{CS0}$	IC14, pin 1	17UH
											$\overline{CS1}$	IC14, pin 2	7375	
												$\overline{CS2}$	IC14, pin 3	253H
												$\overline{CS3}$	IC14, pin 4	8059
												$\overline{CS4}$	IC14, pin 5	PAOU

*This test checks decoding for selection of I/O integrated circuits.

**O = open

TABLE 4-5. CONTROL BOARD ROM 0 TEST (30602)

Signature Analyzer			Bit Switch								Measurement				
Function	Switch Setting	Connection Point	1	2	3	4	5	6	7	8	Item	Point	Signature		
START	}	TP7	Any setting									Common	0000		
STOP		TP7										+5V	826P		
CLK		TP5										D0	IC6, pin 9	25F4	
												D1	IC6, pin 10	U023	
													D2	IC6, pin 11	45F3
													D3	IC6, pin 13	1A1C
													D4	IC6, pin 14	HF57
													D5	IC6, pin 15	8956
													D6	IC6, pin 16	9F70
													D7	IC6, pin 17	9AU8

*This test checks the program content of ROM 0.

TABLE 4-6. CONTROL BOARD ROM 1 TEST* (31502)

Signature Analyzer			Bit Switch								Measurement					
Function	Switch Setting	Connection Point	1	2	3	4	5	6	7	8	Item	Point	Signature			
START	}	TP19	Any setting									Common	0000			
STOP		TP19										+5V	826P			
CLK		TP5										D0	IC7, pin 9	62P5		
													D1	IC7, pin 10	4F59	
														D2	IC7, pin 11	4727
														D3	IC7, pin 13	0756
														D4	IC7, pin 14	U785
														D5	IC7, pin 15	52AU
														D6	IC7, pin 16	66UP
														D7	IC7, pin 17	UH7P

*This test checks the program content of ROM 1 (IC7).

TABLE 4-7. INTERFACE BOARD ROM 2 TEST (31202)

Function	Signature Analyzer		Bit Switch								Item	Measurement	
	Switch Setting	Connection Point	1	2	3	4	5	6	7	8		Point	Signature
START		TP18											
STOP		TP18											
CLK		TP5											
											Any setting	Common	0000
												+5V	826P
											D0	IC1, pin 9	7AF8
											D1	IC1, pin 10	5FAP
											D2	IC1, pin 11	2H19
											D3	IC1, pin 13	FF79
											D4	IC1, pin 14	C9F9
											D5	IC1, pin 15	P015
											D6	IC1, pin 16	PUU0
											D7	IC1, pin 17	3P20

Signature analyzer connection points are on control board.

4-20. SIGNATURE ANALYSIS PROGRAMMED TEST PROCEDURES.

NOTE

Perform the free-running signature analysis tests before proceeding with programmed tests.

A Boonton Electronics diagnostic PROM, part number 53431602, is required for programmed signature analysis tests.

4-21. Use the following general procedure for each of the specified programmed signature analysis tests:

- a. Turn off power to the instrument.
- b. Remove ROMs IC6 and IC7 from their sockets on the control board, and remove ROM IC1 from its socket on the interface board (if option 9200A-01A is installed). (See Figures 6-4 and A-2.)
- c. Install a Boonton Electronics diagnostic PROM, part number 53431602, in the socket from which ROM IC6 was removed, being careful to observe proper pin 1 orientation.
- d. Check to see that connector P1 on the control board is connected to connector J1, and that connector P5 is *disconnected* from connector J5.
- e. Turn on input power to the instrument.
- f. Perform the test procedures specified in Tables 4-8

through 4-23. For each of the programmed signature analysis tests, make signature analyzer connections and switch settings as listed in the appropriate table. Then, set the bit switch on the control board as specified, connect the signature analyzer probe to the specified measurement points, and compare the signatures obtained on the signature analyzer with those listed in the table.

g. Note that in each signature analysis test the signature analyzer probe is first checked on common (ground) and then on +5 volts. If the specified signatures are not obtained for these checks, do not proceed further; subsequent signatures cannot possibly be correct. Recheck all signature analyzer connections and switch settings.

h. Both visual and signature analysis tests are provided for the display and keyboard of the instrument. Make the visual check first; it is fast and simple. If the visual check is satisfactory, the signature analysis test may be omitted.

i. If an incorrect signature is obtained at any point, replace the integrated circuit (or other active device) most intimately associated with the node at which the incorrect signature is obtained. All integrated circuits and transistors in the instrument are socket-mounted for easy removal and replacement. If the signature is still incorrect after all active devices have been checked, all passive devices connected to that node should be suspect.

NOTE

Make sure that power to the instrument is turned off before removing and installing the integrated circuits specified in the following step.

TABLE 4-8. CONTROL BOARD 4ABIO TEST*

Function	Signature Analyzer		Bit Switch**								Item	Measurement Point	Signature
	Switch Setting	Connection Point	1	2	3	4	5	6	7	8			
START	}	TP6										Common +5V PB0 PB1 PB2 PB3 PB4 PB5 PB6 PB7 PB0 PB1 PB2 PB3 PB4 PB5 PB6 PB7 PB0 PB1 PB2 PB3 PB4 PB5 PB6 PB7	0000 0000 0000 0000 0000 0000 0000 0000 0000 4F7C 4F7C 4F7C 4F7C 4F7C 4F7C 4F7C 4F7C
STOP		TP6											
CLK		TP5	C	C	C	C	C	C	C	C			
			O	C	C	C	C	C	C	C			
			C	O	C	C	C	C	C	C			
			C	C	O	C	C	C	C	C			
			C	C	C	O	C	C	C	C			
			C	C	C	C	O	C	C	C			
			C	C	C	C	C	O	C	C			
			C	C	C	C	C	C	O	C			
			C	C	C	C	C	C	O	C			
			C	C	C	C	C	C	O	C			
			C	C	C	C	C	C	O	C			

*This test checks operation of ports A and B of the control module I/O port; the function of the bit switch is checked collaterally.

**O = open; C = closed

TABLE 4-9. CONTROL BOARD 4CIO TEST*

Function	Signature Analyzer		Bit Switch**								Item	Measurement Point	Signature
	Switch Setting	Connection Point	1	2	3	4	5	6	7	8			
START	}	TP6										Common +5V PC0 PC1 PC2 PC3	0000 7C88 5437 CCA9 1788 7C88
STOP		TP6											
CLK		TP5	O	C	C	C	C	C	C	O			

*This test checks the operation of part of port C of the control board I/O port.

**O = open; C = closed

TABLE 4-10. CONTROL BOARD 4DIO TEST*

Function	Signature Analyzer		Bit Switch**								Item	Measurement Point	Signature
	Switch Setting	Connection Point	1	2	3	4	5	6	7	8			
START	}	TP6										Common +5V PC4 PC4	0000 58UA 0000 ^① C35P ^②
STOP		TP6											
CLK		TP5	C	O	C	C	C	C	C	O			

*This test checks the operation of part of port C on the control board I/O port.

**O = open; C = closed

① Line voltage = 120 volts

② Line voltage = 90 volts

TABLE 4-11. DISPLAY VISUAL TEST

Bit Switch*								Instrument Display
1	2	3	4	5	6	7	8	
O	O	C	O	O	C	C	O	In succession: All zeros All ones through all nines All decimal points All left-most annunciators All left-most-1 annunciators All left-most-2 annunciators All right-most annunciators and - sign Repeat of the above

NOTE: If this visual check produces satisfactory results, there is no need to perform the associated signature analysis check.

* O = open; C = closed

TABLE 4-12. CONTROL BOARD DISPLAY TEST* (ROM 950 004)

Function	Signature Analyzer		Bit Switch**								Item	Measurement Point	Signature
	Switch Setting	Connection Point	1	2	3	4	5	6	7	8			
START		TP6									Common +5V D0 D1 D2 D3 D4 D5 D6 D7	IC3, pin 14 IC3, pin 15 IC3, pin 12 IC3, pin 8 IC3, pin 7 IC3, pin 9 IC3, pin 10 IC3, pin 13	0000 F72F 94F8 PH9U 83FF 4A1H H1P5 F3A7 P85F 5536
STOP		TP6											
CLK		TP5											
			O	O	C	O	O	C	C	O			

*This test checks output of digital information to the display. The signature analysis gate in this test is quite lengthy (approximately 8 seconds); hold the signature analyzer probe on each test point for at least one complete window (approximately 20 seconds).

**O = open; C = closed

TABLE 4-13. CONTROL BOARD DISPLAY SCAN TEST*

Function	Signature Analyzer		Bit Switch**								Item	Measurement Point	Signature
	Switch Setting	Connection Point	1	2	3	4	5	6	7	8			
START		TP4									S0 S1 S2 S3	IC18, pin 32 IC18, pin 33 IC18, pin 34 IC18, pin 35	0000 000U 0000 0005 0003 000U
STOP		TP4											
CLK		TP8											
			O	O	C	O	O	C	C	O			

*This test checks the control board display I/O chip for output of encoded scan data.

**O = open; C = closed

TABLE 4-14. KEYBOARD VISUAL TEST*

Bit Switch**								Press Keyboard Key	Instrument Display
1	2	3	4	5	6	7	8		
C	C	O	C	C	C	C	O	MODE mV	0
								MODE dB	1
								RANGE AUTO	2
								LIMITS dB LO	3
								SELECT Z ₀	4
								dB REF LEVEL dB	5
								MODE dBmV	8
								MODE dBV	9
								RANGE HOLD	10
								LIMITS dB HI	11
								SELECT CHNL	12
								CLR	13
								CHS	16
								5	17
								6	18
								7	19
								8	20
								9	21
								•	24
								0	25
								1	26
								2	27
								3	28
								4	29
								ZERO	33

*This test is partly keyboard and partly control board because the I/O chip (IC18) for the display board resides on the control board.

**O = open; C = closed

TABLE 4-15. CONTROL BOARD RAM TEST*

Signature Analyzer			Bit Switch**								Measurement Point	Signature	
Function	Switch Setting	Connection Point	1	2	3	4	5	6	7	8	Item		
START	┌ └┐ └┐	TP6										Common	0000
STOP		TP6										+5V	2915
CLK		TP5											
			O	C	O	C	C	C	C	O	PB0	J3, pin 1	5PPA
											PB1	J3, pin 2	77UU
											PB2	J3, pin 3	5PPA
											PB3	J3, pin 4	77UU
											PB4	J3, pin 5	5PPA
											PB5	J3, pin 6	77UU
											PB6	J3, pin 7	5PPA
											PB7	J3, pin 8	77UU

*This test writes bit patterns into each byte of the RAM, reads each byte and outputs it to the test socket at the rear of the control board where it is checked with the signature analyzer probe. While not completely exhaustive, this test will disclose most RAM failures.

**O = open; C = closed

TABLE 4-16. INPUT MODULE CHANNEL 1 OAIO TEST*

Function	Signature Analyzer		Bit Switch**								Item	Measurement Point	Signature
	Switch Setting	Connection Point***	1	2	3	4	5	6	7	8			
START	}	TP6										Common	0000
STOP		TP6										+5V	876P
CLK		TP5											
			C	O	O	C	C	C	C	O	PA0	IC1, pin 4	485P
											PA1	IC1, pin 3	1A33
											PA2	IC1, pin 2	F85P
											PA3	IC1, pin 1	5H7U
											PA4	IC1, pin 40	OFF1
											PA5	IC1, pin 39	F10C
											PA6	IC1, pin 38	9091
											PA7	IC1, pin 37	4P81

*This test checks the operation of I/O port A of the input module; correct signatures depend on proper functioning of both the control board and the input module.

**O = open; C = closed

***Signature analyzer connection points are on the control board; measurement points are on input module board.

TABLE 4-17. INPUT MODULE CHANNEL 1 OBIO TEST*

Function	Signature Analyzer		Bit Switch**								Item	Measurement Point	Signature
	Switch Setting	Connection Point***	1	2	3	4	5	6	7	8			
START	}	TP6										Common	0000
STOP		TP6										+5V	876P
CLK		TP5											
			O	O	O	C	C	C	C	O	PB0	IC1, pin 18	485P
											PB1	IC1, pin 19	1A33
											PB2	IC1, pin 20	F85P
											PB3	IC1, pin 21	5H7U
											PB4	IC1, pin 22	OFF1
											PB5	IC1, pin 23	F10C
											PB6	IC1, pin 24	9091
											PB7	IC1, pin 25	4P81

*This test checks the operation of I/O port B of the input module; correct signatures depend on proper functioning of both the control board and the input module.

**O = open; C = closed

***Signature analyzer connection points are on the control board; measurement points are on input module board.

TABLE 4-18. INPUT MODULE CHANNEL 1 OCIO TEST*

Signature Analyzer			Bit Switch**								Measurement		
Function	Switch Setting	Connection Point***	1	2	3	4	5	6	7	8	Item	Point	Signature
START	┌ └	TP6										Common	0000
STOP		TP6										+5V	5064
CLK		TP5											
			C	C	C	O	C	C	C	O	PC0	IC1, pin 14	6U01
											PC1	IC1, pin 15	671U
											PC2	IC1, pin 16	CFH2
											PC3	IC1, pin 17	121H

*This test checks the operation of part of I/O port C on the input module; correct signatures depend on proper operation of both the input module and the control board.

**O = open; C = closed

***Signature analyzer connection points are on the control board; measurement points are on input module board.

TABLE 4-19. INPUT MODULE CHANNEL 1 ODIO TEST*

Signature Analyzer			Bit Switch**								Measurement		
Function	Switch Setting	Connection Point***	1	2	3	4	5	6	7	8	Item	Point	Signature
START	┌ └	TP6										Common	0000
STOP		TP6										+5V	23HC ^① or 5C43
CLK		TP5											
			O	C	C	O	C	C	C	O	PB0	A5J3, pin	0000 ^①
											PB0	A5J3, pin	7H97 ^②

*This test checks part of I/O port C of the input module for channel 1.

**O = open; C = closed

***Signature analyzer connection points and measurement points are on control board.

① Signature obtained with range calibrator connected to channel 1 input, and range calibrator set to zero and $R_s = 300k$.

② Signature obtained with range calibrator connected to channel 1 input, and range calibrator set to range 5 and $R_s = 300k$.

TABLE 4-20. INPUT MODULE CHANNEL 2 1AIO TEST*

Signature Analyzer			Bit Switch**								Measurement		
Function	Switch Setting	Connection Point***	1	2	3	4	5	6	7	8	Item	Point	Signature
START	┌ └	TP6										Common	0000
STOP		TP6										+5V	876P
CLK		TP5											
			O	O	C	O	C	C	C	O	PA0	IC1, pin 4	485P
											PA1	IC1, pin 3	1A33
											PA2	IC1, pin 2	F85P
											PA3	IC1, pin 1	5H7U
											PA4	IC1, pin 40	OFF1
											PA5	IC1, pin 39	FIOC
											PA6	IC1, pin 38	9091
											PA7	IC1, pin 37	4P81

*This test checks the operation of I/O port A on input module 2. Correct signatures depend on the proper operation of both the control board and input module 2.

**O = open; C = closed

***Signature analyzer connection points are on the control board; measurement points are on input module board.

Section IV
Maintenance

TABLE 4-21. INPUT MODULE CHANNEL 2 1BIO TEST*

Function	Signature Analyzer		Bit Switch**								Item	Measurement	
	Switch Setting	Connection Point***	1	2	3	4	5	6	7	8		Point	Signature
START		TP6										Common	0000
STOP		TP6										+5V	876P
CLK		TP5										IC1, pin 18	485P
			C	C	O	O	C	C	C	O	PB0	IC1, pin 19	1A33
											PB1	IC1, pin 20	F85P
											PB2	IC1, pin 21	5H7U
											PB3	IC1, pin 22	OFF1
											PB4	IC1, pin 23	FIOC
											PB5	IC1, pin 24	9091
											PB6	IC1, pin 25	4P81
											PB7		

*This test checks the operation of I/O port B of input module 1. Correct signatures depend on proper operation of both the control board and input module 2.

**O = open; C = closed

***Signature analyzer connection points are on the control board; measurement points are on input module board.

TABLE 4-22. INPUT MODULE CHANNEL 2 1CIO TEST*

Function	Signature Analyzer		Bit Switch**								Item	Measurement	
	Switch Setting	Connection Point***	1	2	3	4	5	6	7	8		Point	Signature
START		TP6										Common	0000
STOP		TP6										+5V	5064
CLK		TP5										IC1, pin 14	6UO1
			O	C	O	O	C	C	C	O	PC0	IC1, pin 15	671U
											PC1	IC1, pin 16	CFH2
											PC2	IC1, pin 17	121H
											PC3		

*This test checks the operation of I/O port C of input module 2. Correct signatures depend on proper operation of both the control board and input module 2.

**O = open; C = closed

***Signature analyzer connection points are on the control board; measurement points are on input module board.

TABLE 4-23. INPUT MODULE CHANNEL 2 IDIO TEST*

Function	Signature Analyzer		Bit Switch**								Item	Measurement	
	Switch Setting	Connection Point***	1	2	3	4	5	6	7	8		Point	Signature
START	┌ └	TP6										Common +5V A5J3, pin 1 A5J3, pin 1	0000
STOP		TP6											P951 ^① or 1088
CLK		TP5											
			C	O	O	O	C	C	C	O		PB0 PB0	7H97 ^②

*This test checks part of I/O port C of the channel 2 input module.

**O = open; C = closed

***Signature analyzer connection points and measurement points are on control board.

① Signature obtained with range calibrator connected to channel 2 input, and range calibrator set to zero and $R_s = 300k$.

② Signature obtained with range calibrator connected to channel 2 input, and range calibrator set to range 5 and $R_s = 300k$.

j. At the completion of all programmed signature analysis tests, *turn off power* to the instrument, remove the Boonton Electronics diagnostic PROM from the control board, and install ROMs IC6 and IC7 in their sockets on the control board and ROM IC1 in its socket on the interface board, ensuring that proper pin 1 orientation is observed.

k. Restore bit switch (Figure 4-3) on the control board to the settings recorded at the start of signature analysis tests.

l. Connect connector J5 on the control board to connector P5.

4-22. NON-VOLATILE RAM CIRCUIT TESTS.

4-23. Non-Volatile RAM Test. To test the non-volatile RAM, proceed as follows:

CAUTION

This test will destroy and overwrite instrument data stored in the non-volatile RAM, necessitating reloading of data. This test should be made only as a last resort, or if it has been determined that stored instrument data has already been lost or is faulty.

NOTE

Leave Boonton Electronics diagnostic PROM, part number 950004, installed on the control board as for the programmed signature analysis tests. Make sure that connector P5 on the control board is connected to connector J5.

a. With power applied to the instrument, set all eight segments of the bit switch on the control board to the open position.

b. Observe the instrument display. It should provide an error indication (cccc) initially.

c. Turn input power off, then back on. If the non-volatile RAM is operating properly, the instrument display will show 1111.

d. Repeat step c several times. The instrument display should always show 1111, not the error indication.

e. Upon completion of this test, turn off input power to the instrument, remove the diagnostic PROM from the control board, and install integrated circuits IC6 and IC7 in their sockets on the control board and integrated circuit IC1 on the interface board (if option 9200A-01A is installed), making certain that proper pin 1 orientation is observed.

4-24. Non-Volatile RAM Battery Test. To test the non-volatile RAM battery, proceed as follows:

CAUTION

The following test procedure must be adhered to strictly; otherwise, instrument data stored in the non-volatile RAM may be lost. Do not attempt to make measurements other than those specified. Take all necessary precautions to ensure that no terminals are shorted to another terminal or to common (ground).

a. Remove the three screws that secure the non-volatile

Section IV Maintenance

RAM cover and remove the cover to gain access to the battery terminals.

b. Connect a digital voltmeter between common and terminal 4 (Figure 4-4), ensuring that the battery is not shorted to ground at any time.

c. Observe the digital voltmeter indication; it should be at least 5 volts with input power to the instrument turned off. If the indication is less than 5 volts, the battery is probably nearing the end of its useful life; replace the battery in accordance with the procedures in paragraph 4-25.

NOTE

The load imposed on the battery by the non-volatile RAM is 5.25 microamperes or less. With this load, the battery has a rated life of at least 100,000 hours, which is more than 10 years.

4-25. Non-Volatile RAM Battery Replacement. To replace the non-volatile RAM battery, proceed as follows:

CAUTION

The following battery replacement procedure must be followed strictly; otherwise, instrument data stored in the non-volatile RAM will be lost. The battery replacement procedure must be performed with input power applied to the instrument; loss of power with the battery disconnected will result in the loss of stored data. Use a UL-approved soldering iron that has its exposed parts grounded.

a. *Make sure that input power to the instrument is turned on.*

b. Disconnect the battery lead connected to instrument ground (point 1 in Figure 4-4). Insulate this lead to prevent electrical contact with any other terminal or electrical part.

c. Disconnect the other lead (2) of the same cell, and remove the cell.

d. Disconnect leads (3 and 4) of the other cell, and remove this cell.

e. Install a new cell in place of the cell removed in preceding step d. Observe cell polarity. Connect the cell leads to points 3 and 4 in Figure 4-4.

f. Insulate the negative lead of the other new cell, and install this cell in place of the cell removed in step c.

Connect the positive lead of this cell to point 2 in Figure 4-4.

g. Remove the insulator from the negative lead, and connect the negative lead to point 1 in Figure 4-4.

h. If the LED in the non-volatile RAM circuit glows, disconnect the cell lead from common terminal (1, Figure 4-4) promptly, and insulate this lead. Lighting of the LED indicates that a malfunction exists and heavy current is being drawn from the battery. Do not proceed until the problem has been corrected.

i. Perform the battery test specified in paragraph 4-24. The voltage indication for a new battery should be 5.6 to 5.9 volts.

j. Connect a dc voltmeter capable of making above-ground measurements (neither terminal connected to instrument common) across 100-ohm resistor R6 on the control board. With line power on, the dc voltmeter should indicate approximately zero; with line power off, the dc voltmeter should indicate 525 microvolts or less.

k. When correct test results have been obtained, install the cover of the nonvolatile RAM and the three cover retaining screws.

4-26. NON-VOLATILE MEMORY DATA.

NOTE

Factory-entered data is shown on a hard copy stored under the right side panel of the instrument.

4-27. General. Data have been entered in to the non-volatile memory of the instrument at the factory for the instrument and for the probe(s) ordered with the instrument. Field entry of data is not required unless stored data are destroyed or their accuracy becomes suspect, or if another probe is to be used with the instrument. A description of the types of data stored in non-volatile memory is provided in the following paragraphs.

4-28. Instrument Gain Data. The front end of the instrument input module is a balanced-input dc amplifier with seven decade ranges with nominal full-scale inputs of 20 microvolts to 20 volts. The output is an unbalanced dc with a 2.5 volt full-scale value for each range; this dc is converted into a proportional digital value. One manual gain adjustment, potentiometer R44, adjusts the gain of all ranges by the same amount; this adjustment is factory set during instrument calibration. Individual range adjustments are accomplished through software correction or adjustment, which is also determined during instrument calibration.

The software corrections are stored in the instrument non-volatile memory. A gain factor associated with the recorder dc output is also stored in memory.

4-29. Probe Data. Low-frequency gain corrections are stored in the instrument non-volatile memory for each probe that is calibrated with the instrument. Low-frequency gain corrections are of two types: a gain factor for each range, and a gain correction for each range. Any probe procured independently of the instrument must have its low-frequency gain data entered and stored in the non-volatile memory prior to the use of that probe.

4-30. Instrument Operation-Related Data. Instrument gain data and probe data are fixed for a given instrument and probe(s). The instrument non-volatile memory stores these together with measurement parameters most recently selected by the operator. Entry of measurement parameters is described in paragraph 2-15. The non-volatile memory retains the operator-selected parameters until they are changed, maintaining current values through power off/power on.

4-31. RECALL AND ENTRY OF INSTRUMENT GAIN DATA.

4-32. The following subparagraphs provide instructions for recall and entry of instrument gain data.

a. **Gain Factor Recall.** To recall the instrument gain factors stored for each channel of the instrument, proceed as follows:

1. Set the control board bit switch to mode 1. (See Figure 4-3.)
2. Using the instrument keyboard, select the channel for which gain factors are to be recalled. For example: to select channel 1, press the 1 and SELECT CHNL keys.
3. Press the RANGE AUTO key. The instrument display will show approximately 1185; this is the recorder output gain factor.
4. Using the keyboard keys, select the range to be checked. For example: to select range 0, press the 0 and MODE dBV keys.
5. Press the dB REF LEVEL dB key. The instrument display will indicate the gain factor stored for the selected channel and range; this value should be in the vicinity of 1000.
6. Repeat steps 3 and 5 for each of the remaining ranges to be checked.
7. After all desired gain factors have been recalled, reset the control board bit switch (Figure 4-3) to mode 0.

b. **Instrument Gain Factor Entry.** To correct or reintroduce an instrument gain factor, proceed as follows:

1. Set the control board bit switch (Figure 4-3) to mode 1.

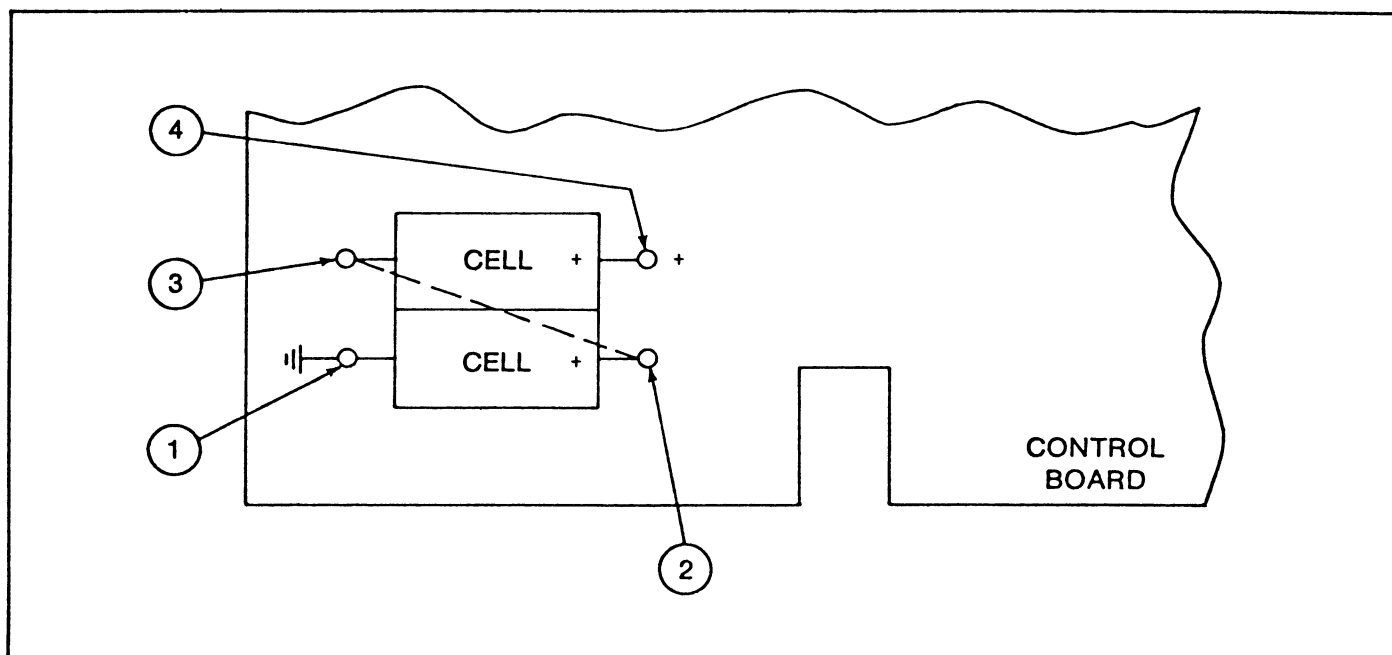

Figure 4-4 Non-Volatile RAM Battery Test and Connection Points

Section IV Maintenance

2. Using the keyboard keys, select the channel for which gain factor correction or reintroduction is required. For example: to select channel 2, press the 2 and SELECT CHNL keys.

3. Using the keyboard keys, select the range for which the gain factor is to be corrected or reintroduced. For example: to select range 2, press the 2 and MODE dBV keys.

4. Using the keyboard keys, enter the desired gain factor as a dB REF LEVEL dB value. For example: to enter a gain factor of 1023, press the 1, 0, 2, and 3 numeric keys, then press the dB REF LEVEL dB key.

5. Press the dB REF LEVEL dB key a second time. The instrument display will indicate the entered gain factor value.

6. Repeat steps 3 through 5 for each of the remaining ranges for which entry of a gain factor is desired.

7. Upon completion of gain factor entries, reset the control board bit switch (Figure 4-3) to mode 0.

4-33. RECALL AND ENTRY OF PROBE DATA.

4-34. Gain factor and gain correction data are stored in the instrument non-volatile memory for each probe supplied with the instrument. To recall or enter probe data, use the following procedures, as applicable.

a. Probe Data Recall. To recall stored probe data, proceed as follows:

1. Set the control board bit switch (Figure 4-3) to mode 0.

2. Using the keyboard keys, select the channel for which stored probe data is to be recalled. For example: if stored data for the channel 1 probe is to be recalled, press the 1 and SELECT CHNL keys.

3. Set the control board bit switch to mode 2.

4. Using the keyboard keys, select the range for which the probe gain factor is desired. For example: if the gain factor for range 0 is to be recalled, press the 0 and MODE dBV keys.

5. Press the dB REF LEVEL dB key. The instrument display will show the stored gain factor (approximately 5000) for the selected range.

6. Press the RANGE AUTO key. The instrument

display will show a down-scale correction (generally 0 on range 0).

7. Repeat steps 4 through 6 for each of the other ranges for which the stored gain factor is to be recalled.

8. Set the control board bit switch (Figure 4-3) to mode 0.

b. Entry of Probe Gain Factor and Gain Correction. Proceed as follows:

1. Using the keyboard keys, select the probe for which the data is to be entered. For example: if the data to be entered applies to the probe used with channel 1, press the 1 and SELECT CHNL keys.

2. Set the control board bit switch (Figure 4-3) to mode 2.

3. Using the keyboard keys, select the range for which a probe gain factor entry is to be made. For example: if the probe gain factor for range 0 is to be entered, press the 0 and MODE dBV keys.

4. Using the numerical keys, enter the probe gain factor for the selected range; then, press the dB REF LEVEL dB key. For confirmation of correct probe gain factor entry, press the dB REF LEVEL dB key a second time; the stored probe gain factor for the selected range will appear on the instrument display.

5. Repeat steps 5 and 6 for each of the other instrument ranges for which probe gain factors are to be entered.

6. Select the instrument range for which the probe gain correction is to be entered. For example: if the probe gain correction for range 2 is to be entered, press the 2 and MODE dBV keys.

7. Using the numerical keys, enter the probe gain correction for the selected range, then press the RANGE HOLD key. For confirmation of correct probe gain correction entry, press the RANGE HOLD key a second time; the stored gain correction for the selected range will appear on the instrument display.

8. Repeat steps 8 and 9 for each of the other instrument ranges for which probe gain corrections are to be entered.

9. Upon completion of data entry, reset the control board bit switch (Figure 4-3) to mode 0.

4-35. INSTRUMENT ADJUSTMENT AND CALIBRATION

4-36. GENERAL. Test equipment required for instrument adjustment and calibration is as follows:

- a. Digital voltmeter (3-½ digits).
- b. RF Millivoltmeter Calibrator, Boonton Electronics Model 26A.
- c. Range Calibrator, Boonton Electronics Model 2500.

NOTE

In the following adjustment procedures, all voltage measurements are referred to common unless otherwise specified.

4-37. Power Supply Adjustments. With all power connectors in place, the instrument controls set for line operation, and the correct line voltage applied, make power supply adjustments as follows:

- a. Connect the digital voltmeter between common and test point TP3. The voltage indication should be 5.20 ± 0.002 volts. Adjust potentiometer R5 on the power supply board as required to obtain the specified indication.
- b. Connect the digital voltmeter between test points TP2(-) and TP4(+). The voltage indication should be 150 ± 10 millivolts. Adjust potentiometer R11 on the power supply board as required to obtain the specified indication.
- c. Connect the digital voltmeter between test point TP1 and common. The voltage indication should be $+15 \pm 0.6$ volts.
- d. Connect the digital voltmeter between test point TP5 and common. The voltage indication should be -15 ± 0.6 volts.
- e. Connect the digital voltmeter between test point TP6 and common. The voltage indication should be -5 ± 0.2 volts.

4-38. Input Module Calibration and Adjustments. The input modules are capable of operating with either:

- Model 952001 High Impedance Probe
- Model 952009 50 ohm Probe

In the adjustments which follow, the Model 2500 source resistance should be set as follows:

PROBE	SOURCE RESISTANCE
Model 952001	300 k
Model 952009	500 k

a. Connect 2500 to Sensor port on 9200A front panel (rear panel for 2nd channel). If there are 2 inputs, input 1 is mounted under input 2; input 2 must be removed to calibrate input 1. Adjust input 1 first. Set control board bit switch (Figure 4-3) to Calibrate Model 1.

b. Depress 2500 ZERO and set to RANGE 0. On 9200A, depress 1 CHNL, 0 dBV, mV.

c. Set DMM to dcV and connect to TP9 on Input Module.

d. Short TP7 & 8 on Input Module to ground. Adjust R45 for 0 Vdc ± 15 mVdc.

e. Remove ground from TP8 and adjust R36 for 0 Vdc ± 15 mVdc. NOTE: If R24 is omitted remove GRND from TP7 and go to step g.

f. Remove ground from TP7 and connect DMM to TP5. Adjust R24 for 0Vdc ± 0.1 Vdc.

g. Connect DMM to TP9. Adjust R4 & R5 equally for a reading between 0 Vdc and -0.2 Vdc, but as close to 0 Vdc as possible. Remove DMM.

h. On 9200A, depress ZERO. After zero cycle is completed set 2500 to range 5 and release ZERO. Depress 5 dBV and adjust R1 for 184.3 on 9200A display (See note below). Set 2500 to RANGE 2, depress 2 dBV, and record display reading. Set 2500 to RANGE 1 and adjust R11 for one tenth of reading recorded in RANGE 2.

EXAMPLE: RANGE 2 read 184.3, set RANGE 1 for 018.4.

NOTE

If there is not enough range on R1 or R11, center R1 and R11 with 2500 set to RANGE 5, and adjust R44 for 184.3 on display. Set 2500 to RANGE 1 and adjust R11 as indicated in step "h". There is some interaction between R1 and R11 so re-check adjustments.

For 2nd Input Module calibration repeat steps "a" thru "h" at Sensor port on rear panel marked 2nd CHNL. Step "b" should be 2 CHNL. Number 2 Input Module is mounted on top of number 1 Input Module.

i. Set control board bit switch (Figure 4-3) to Operate Mode.

Section IV Maintenance

4-39. DC Calibration. Make DC calibration adjustments as follows:

a. Connect 2500 to Sensor port to be calibrated. Set control board bit switch (Figure 4-3) to Operate Mode. Depress 2500 ZERO and set to RANGE 0.300 k (500 k for 952009 sensor). On 9200A, depress 1 CHNL (2 CHNL for 2nd CHNL calibration), 0dB REF. LEVEL, ZERO. After zero cycle is complete, set control board bit switch to Calibrate Mode 1. On 9200A, depress 1, 0, 0, 0, MODE dB.

b. Set 2500 to RANGE 0, depress 0 dBV, allow instrument time to settle, 18.43, mode dBmV, HI, dB REF. LEVEL.

c. Set 2500 to RANGE 1, depress 1 dBV, settle, HI, dB REF. LEVEL.

d. Set 2500 to RANGE 2, depress 2 dBV, settle, HI, dB REF. LEVEL.

e. Set 2500 to RANGE 3, depress 3 dBV, settle, HI, dB REF. LEVEL.

f. Set 2500 to RANGE 4, depress 4 dBV, settle, HI, dB REF. LEVEL.

g. Set 2500 to RANGE 5, depress 5 dBV, settle, HI, dB REF. LEVEL.

h. Set 2500 to RANGE 6B, depress 6 dBV, settle, HI, dB REF. LEVEL.

i. Remove 2500. Set control board bit switch to Operate Mode.

4-40. A.C. Calibration. The a.c. calibration consists of three items: channel selection, shaping table selection, and three adjustments for each range. To perform the a.c. calibration, proceed as follows:

a. Connect the probe to the Mode 26A Calibrator⁽¹⁾ and allow both the calibrator and the Model 9200A to warm up for at least one-half hour. Depress the ZERO button on the Model 26A. On the Model 9200A, select Channel 1 or Channel 2, as required.

⁽¹⁾When calibrating the Model 952009 sensor, the internal 50-ohm shunt on the output of the Model 26A Calibrator must first be disconnected.

b. Select the proper shaping table by setting the bit switch to AC CALIBRATION MODE 2 and pressing 0, SELECT Z₀, for Model 952001 High Impedance Probe; or 1, SELECT Z₀, for Model 952009 50-ohm Sensor. Leave the control board bit switch in AC CALIBRATION MODE 2 for subsequent operations.

NOTE

The result of any adjustment or correction can be determined at any time by returning the control board bit switch to the OPERATE MODE and pressing RANGE AUTO and MODE mV keys. Return to AC CALIBRATION MODE 2 if further calibration is to be done.

c. Clear previous midscale and downscale corrections by pressing:

0, MODE dBV,	0, RANGE AUTO,	0, RANGE HOLD	(CLEARS RANGE 0)
1, MODE dBV,	0, RANGE AUTO,	0, RANGE HOLD	(CLEARS RANGE 1)
2, MODE dBV,	0, RANGE AUTO,	0, RANGE HOLD	(CLEARS RANGE 2)
3, MODE dBV,	0, RANGE AUTO,	0, RANGE HOLD	(CLEARS RANGE 3)
4, MODE dBV,	0, RANGE AUTO,	0, RANGE HOLD	(CLEARS RANGE 4)
5, MODE dBV,	0, RANGE AUTO,	0, RANGE HOLD	(CLEARS RANGE 5)
6, MODE dBV,	0, RANGE AUTO,	0, RANGE HOLD	(CLEARS RANGE 6)

NOTE

Pressing "N" and then MODE dBV selects range "N". Pressing 0 and then RANGE AUTO clears midscale correction. Pressing 0 and then RANGE HOLD clears downscale correction.

d. Zero the Model 9200A by pressing 0, MODE dBV, MODE mV, ZERO. Wait for the completion of the zeroing process (digit display blanks, then returns). If the zero indication is not less than ± 50 counts, repeat zero until this is obtained. In step e which follows, the instrument should be re-zeroed, if necessary, just prior to adjusting each of the three lowest ranges.

e. To adjust the full scale gain, set the Models 26A and 9200A as follows:

MODEL 26A	MODEL 9200 PRESS		MODEL 9200A DISPLAY
0.7 mV	0, MODE dBV,	7,..,0,0, MODE dBmV, (WAIT) ⁽²⁾	LIMITS dB HI, dB REF LEVEL dB = 5000 ⁽³⁾
2.1 mV	1, MODE dBV,	2,1,..,0,0, MODE dBmV, (WAIT)	LIMITS dB HI, dB REF LEVEL dB = 5000
7 mV	2, MODE dBV,	7,0,..,0,0, MODE dBmV, (WAIT)	LIMITS dB HI, dB REF LEVEL dB = 5000
24 mV	3, MODE dBV,	2,4,..,0,0, MODE dBmV, (WAIT)	LIMITS dB HI, dB REF LEVEL dB = 5000
100 mV	4, MODE dBV,	9,9,..,0,0, MODE dBmV, (WAIT)	LIMITS dB HI, dB REF LEVEL dB = 5000
700 mV	5, MODE dBV,	7,0,..,0,0, MODE dBmV, (WAIT)	LIMITS dB HI, dB REF LEVEL dB = 5000
3000 mV	6, MODE dBV,	3,0,..,0,0, MODE dBmV, (WAIT)	LIMITS dB HI, dB REF LEVEL dB = 5000

⁽²⁾ Allow sufficient time for display to settle.

⁽³⁾ An indication between 4500 and 5500 is probably normal.

After each range adjustment above, the quality of the adjustment may be examined by setting the bit switch on the control board to OPERATE mode and pressing the MODE mV and RANGE AUTO keys; the indication should agree with the input (Model 26A setting) within several counts. If closer agreement is desired, either repeat the procedure for that range or manually adjust the gain factor for that range by pressing:

X,X,X,X, dB REF LEVEL dB

EXAMPLE:

After the normal routine, the indication for the 100 mV range is 99.8 (0.2% low). Set the bit switch to CALIBRATE MODE 2 and recall the gain factor by pressing 4, MODE dBV, dB REF LEVEL dB.

A gain factor of 5040 is displayed. The desired change is +0.2%. Increase the gain factor by 0.2% (= 10) to 5050 and enter by pressing:

5,0,1,0, dB REF LEVEL dB

Recheck in the OPERATE mode.

f. **Midscale Correction.** In step c all the midscale corrections were set to 0 (no correction), and for the majority of probes this is quite satisfactory. If it is found that a midscale correction is desirable it may be introduced as follows:

MODEL 26A	MODEL 9200A PRESS	
1.5 mV	1, MODE dBV,	X,X,X, RANGE AUTO
5 mV	2, MODE dBV,	X,X,X, RANGE AUTO
15 mV	3, MODE dBV,	X,X,X, RANGE AUTO
60 mV	4, MODE dBV,	X,X,X, RANGE AUTO
300 mV	5, MODE dBV,	X,X,X, RANGE AUTO
1500 mV	6, MODE dBV,	X,X,X, RANGE AUTO

The midscale correction will also affect the full scale indication, but to a lesser degree. Full scale may be readjusted as was outlined in step e. This will, however, affect the midscale correction again. Moreover, there is not a one-to-one relationship between the counts entered for the midscale correction and the correction which results.

If one does not wish to readjust full scale, enter the number of counts that midscale is in error; this will result in under-correction for midscale but will disturb full scale the least.

If the greatest accuracy is desired and full scale will be readjusted, enter three times the counts by which midscale is in error.

EXAMPLE:

The 3000 mV range having just been calibrated is reading 3000 mV. However, 1500 (midscale) is reading 1497; The error here is three counts. Correct as follows:

CORRECTION (AUTO)	AFTER CORRECTION		COMMENT
	MID	FULL	
0	1497	3000	No midscale correction
3	1498	3001	No full scale adjustment
9 (3 x 3)	1501	3004	No full scale adjustment
9 (3 x 3)	1499	3000	Full scale re-adjusted

Section IV
Maintenance

g. **Downscale Correction.** To correct downscale indications, proceed as follows:

MODEL 26A		MODEL 9200A PRESS
0.21 mV	0, MODE dBV	X,X,X, RANGE HOLD
1.0 mV	1, MODE dBV	X,X,X, RANGE HOLD
2.4 mV	2, MODE dBV	X,X,X, RANGE HOLD
10 mV	3, MODE dBV	X,X,X, RANGE HOLD
30 mV	4, MODE dBV	X,X,X, RANGE HOLD
210 mV	5, MODE dBV	X,X,X, RANGE HOLD
1000 mV	6, MODE dBV	X,X,X, RANGE HOLD

Again, there is not a one-to-one relationship between the value entered and the correction which results. For these corrections, enter a value which is twice the desired correction. Downscale corrections have no effect on full scale indications. The reverse is not true however; therefore, full scale adjustment (and midscale corrections, if used) should be made prior to downscale corrections.

h. **Calibration Check.** Finally, check the results of calibration at the following levels:

SCALE	RANGE	INPUT
Full	6	3000 mV
Mid	6	1500 mV
Down	6	1000 mV
Full	5	700 mV
Mid	5	300 mV
Down	5	210 mV
Full	4	100 mV
Mid	4	60 mV
Down	4	30 mV
Full	3	24 mV
Mid	3	15 mV
Down	3	10 mV
Full	2	7 mV
Mid	2	5 mV
Down	2	2.4 mV
Full	1	2.1 mV
Mid	1	1.5 mV
Down	1	1.0 mV
Full	0	0.7 mV
Mid	0	0.5 mV
Down	0	0.21 mV

All indications should fall well within the uncertainties specified in the Performance Specifications of Section I, Table 1-3.

NOTE

Because of range overlap it is possible in some instances to get an indication on two adjacent ranges for the same input level. Generally the indication near full scale (as opposed to downscale on the next higher range) will be the more accurate.

4-41. DC Recorder Calibration. Make DC Recorder adjustments as follows:

a. Set control board bit switch to Operate Mode. If the instrument is equipped with channel 2 (option 9200A-03), temporarily remove option to gain access to R55 on channel 1 (accessible through hole in channel 1 cover).

b. Connect DMM to recorder BNC connector on rear panel. Connect RF Probe to channel to be calibrated and to the 26A. Set 26A to ZERO. On 9200A, depress 1 channel (2 channel if 2nd channel is to be calibrated), 0, dB REF. LEVEL, AUTO, mV, ZERO.

c. After ZERO cycle is completed, set 26A to 1000 mV. DMM should read 10V for display of 1000 mV $\pm 0.1\%$. If not, set control board bit switch to Calibrate Mode 1. Depress AUTO. Display should read approximately 1170. Perform the following: [Display indication \div (100 x DMM indication)] x the number located in AUTO.

EXAMPLE: Display reads 1000. DMM reads 9.96. AUTO reads 1163. $[1000 \div (100 \times 9.96)] \times 1163 = 1168$.

d. With control board bit switch in Calibrate Mode 1, depress the number calculated above (i.e., 1168) followed by AUTO. Set control board bit switch to Operate Mode. Depress HOLD. Check DMM for accuracy indicated above. Set 26A for 300 mV. Adjust R55 for DMM to read 3V for 300 mV display.

EXAMPLE: Display reads 0299. DMM reads 2.97. Adjust DMM to read 2.99. Full scale and down scale adjustments interact so re-check full scale and down scale until accuracy is obtained. Set control board bit switch to Operate Mode when complete.

e. This completes all 9200A calibration adjustments.

4-42. PROBE SWR AND FREQUENCY RESPONSE TESTS.

4-43. General. The RF probe and probe accessories used with the instrument can be checked for SWR and frequency response using the procedures in the following paragraphs. If an RF probe should exhibit out-of-tolerance performance in these tests, do not attempt to repair the probe; return it to the factory for repair or adjustment.

4-44. SWR Test. Proceed as follows:

a. Connect a slotted line to a signal source of the desired frequency range, and terminate the slotted line with the accessory device to be tested (i.e., Model 952003 50-Ohm N Tee Adapter and Model 952014 50-Ohm N Termination, or Model 952002 50-Ohm BNC Adapter).

b. Connect the RF probe and RF millivoltmeter to the accessory being tested. The RF probe supplies a perturbation for which the accessory has been designed, and the RF millivoltmeter permits the test level to be set to the desired value.

c. Move the carriage of the slotted line to a point of minimum voltage, then to a point of maximum voltage. Record the minimum and maximum voltage values.

d. The SWR is the ratio of the maximum and minimum voltages.

e. Repeat the SWR measurement at other frequencies and levels, as required.

4-45. Frequency Response Tests. The most accurate method of measuring the frequency response of the RF probe is through use of micropotentiometers, electrothermic ac-dc transfer instruments, and attenuator-thermoelement voltmeters. Users who have such instruments available will be familiar with their use. Another method, with an accuracy compatible with the accuracy of the instrument, uses a point-by-point frequency scan in conjunction with a power splitter and calibrated RF microwattmeter. To use this method, proceed as follows:

a. Connect the equipment as shown in Figure 4-5.

b. Set the frequency of the signal generator to 10 MHz, and adjust the signal generator output to the desired test level. If the response is to be measured at only one level, a test voltage of 100 millivolts is recommended.

c. Disable the output of the signal generator momentarily and zero the RF microwattmeter.

d. Restore the signal generator output level and note the reading on the RF microwattmeter. Record the frequency of the signal generator and the indication on the RF millivoltmeter.

e. Change the signal generator output frequency, in whatever increments are desired, through the range of 10 to 1200 MHz, holding the reference reading on the RF microwattmeter constant. Record the frequency and RF millivoltmeter indication for each test frequency.

f. Reverse the output ports of the power splitter, and repeat steps b through e.

g. Average the two readings obtained for each test frequency to obtain the correct RF millivoltmeter reading.

h. Further refinements can be made by filtering the output of the signal generator and measuring the complex reflection coefficients of the RF microwattmeter, accessory under test, and all ports of the power splitter. The usual corrections can then be made. These procedures are not usually necessary, and should be performed only if the additional accuracy is warranted.

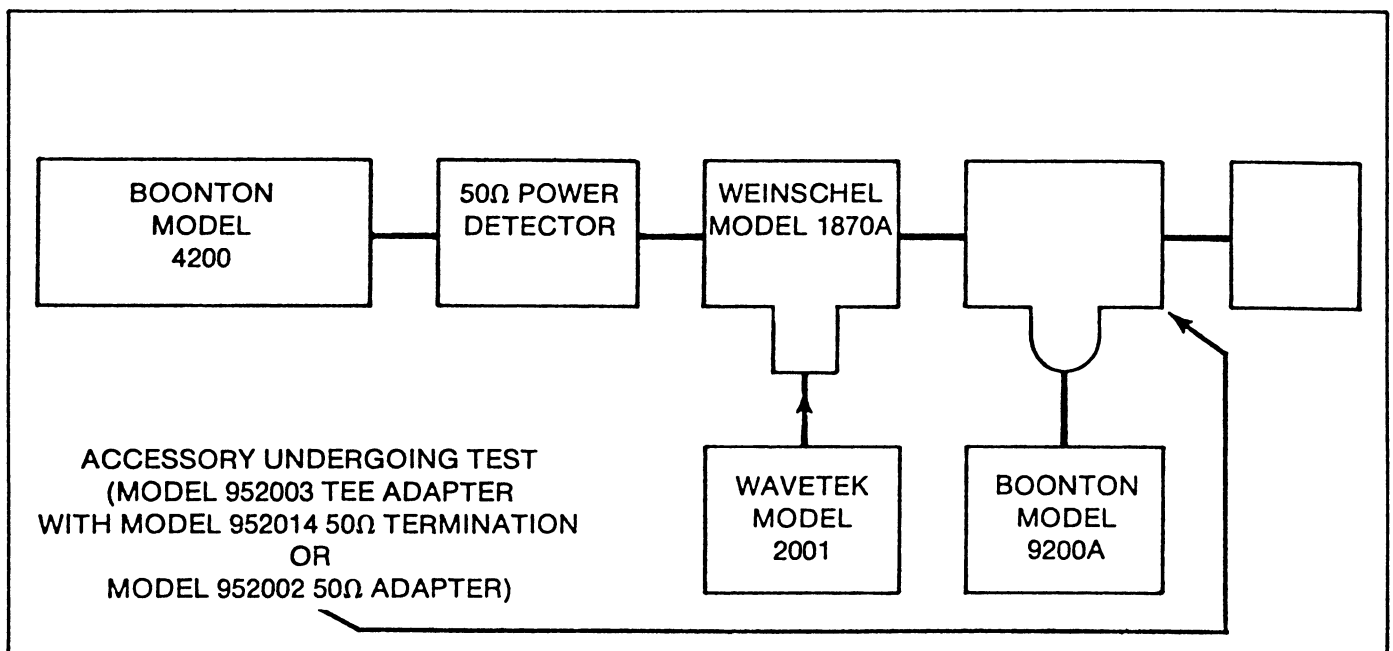

Figure 4-5 RF Probe Frequency Response Test Setup

Section IV
Maintenance

4-46. Alternate Frequency Response and SWR Test Procedure. An alternate method of measuring both the frequency response and SWR (in terms of the reflection coefficient), with somewhat reduced accuracy, uses a sweep generator, SWR bridge, external leveling of the generator, power splitter, and sensitive oscilloscope. The procedure is as follows:

- a. Connect the equipment as shown in Figure 4-6.
- b. Disconnect the RF probe cable from the oscilloscope, and connect it temporarily to an RF millivoltmeter. Adjust the output control of the sweep generator to provide an RF millivoltmeter indication of 100 millivolts at a fixed frequency of 100 MHz. Then, restore the original RF probe connection to the oscilloscope.
- c. Calibrate one of the vertical input amplifiers of the oscilloscope for a sensitivity of 100 microvolts per division. Calibrate the other vertical input amplifier so that a change from 100 millivolts to 90 millivolts applied to the input of the RF probe under test will produce a vertical deflection of 1 division. This can be done easily with a Boonton Model 26A RF Millivoltmeter Calibrator; connect the RF probe temporarily to the output of the RF millivoltmeter calibrator, adjust the output of the RF millivoltmeter calibrator to 100 millivolts and 90 millivolts alternately, and adjust the

sensitivity of the second vertical amplifier for a deflection of 1 division.

d. The SWR channel may be zeroed with a 50Ω termination (SWR <1.02) before connecting the mismatch termination. Substitute the standard 1.2:1 mismatch termination for the accessory under test, and calibrate the graticule of the oscilloscope for the SWR of 1.2. Reconnect the accessory and probe.

e. Adjust the limits on the three bands of the sweep generator for coverage from 10 to 1200 MHz. Study the traces of both the frequency-response and SWR (return loss).

f. Reverse the output ports of the power splitter and repeat steps d and e.

g. Note that the permissible error for the frequency response trace expands with frequency. For the most meaningful results, mark the graticule with a grease pencil to show the maximum permissible errors for the various frequency bands, as determined with a calibrated signal of 1 MHz, and at levels above and below the selected test level. Note also that the recovered dc from the RF probe, which is applied to the second vertical input amplifier, will vary as the square of the RF input level for test levels of 30 millivolts or less. Above 30 millivolts, RF to dc conversion gradually changes from square law to linear, and approaches a peak-to-peak rectifier at an input of 3 volts.

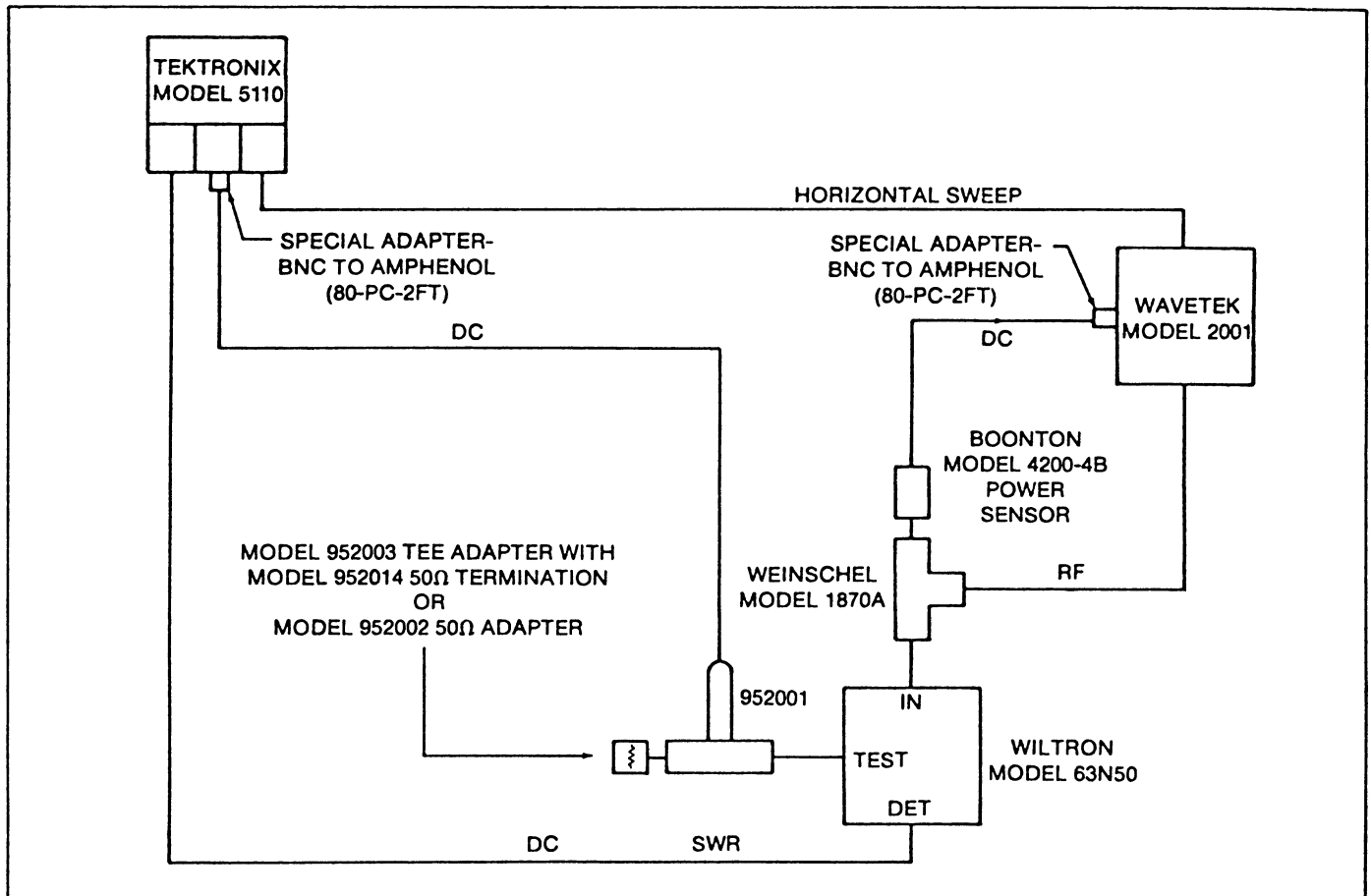

Figure 4-6 Swept Frequency Response Test Setup

SECTION V
PARTS LIST

TABLE OF REPLACEABLE PARTS

Reference	Description			BEC Part No.
FRAME ASSEMBLY (A1)				
S1	Switch, Toggle	D.P.D.T.	Carling 6-30-1-5-4-2-1	465281
REAR PANEL ASSEMBLY				
F1	Fuse, Slo-Blo	0.3 A 120 V	Buss MDL 3/10	545507
F1	Fuse, Slo-Blo	0.2 A 240 V	Buss MDL 2/10	545508
J20	Receptacle, BNC		Dage 081-1	479123
T1	Transformer, Power		Boonton Electronics	446091
DISPLAY PC BOARD ASSEMBLY				
A1	Op. Amp.	CA3140AE	RCA	535050
C1	Capacitor, Cer.	33 pF 5% 1 kV	Sprague C0308102G330J	224139
C2	Capacitor, Tant.	6.8 μ F 10% 35 V	Sprague 196D685X9035KA1	283217
C3	Capacitor, Tant.	6.8 μ F 10% 35 V	Sprague 196D685X9035KA1	283217
C4	Capacitor, Tant.	6.8 μ F 10% 35 V	Sprague 196D685X9035KA1	283217
C5	Capacitor, Cer.	1000 pF 10% 1 kV	Sprague 10TS-D10	224310
CR1 through CR13	Diode, LED	IT/F-536024	H.P.	536022
IC1	Integrated Circuit	MM74C48N	National Semiconductor	534214
IC2	Integrated Circuit	CD4051BE	RCA	534139
IC3	Integrated Circuit	CD4049AE	RCA	534172
IC4	Resistor Network	100 Ω 2% 1.8 W	AB316B101	345021
IC5	Resistor Network	4.7 k Ω 2% 1.8 W	AB316B472	345020
IC6	Numeric Display	HP5082-7653	H.P.	536809
IC7	Integrated Circuit	DS8863N	National Semiconductor	534215
IC8	Numeric Display	HP5082-7653	H.P.	536809
IC9	Numeric Display	HP5082-7653	H.P.	536809
IC10	Numeric Display	HP5082-7653	H.P.	536809
IC11	Numeric Display	HP5082-7656	H.P.	536810
M1	Meter	OMS-DMA001-CD	Modutec	554332
Q1	Transistor, NPN	2N5088	Motorola	528047
R1	Resistor, MF	93.1 k Ω 1%	RN55	341493
R2	Resistor, Comp.	91 k Ω 5%	AB-EB	343492
R3	Resistor, MF	1.0 M Ω 1%	RN55	341600
R4	Resistor, MF	9.09 k Ω 1%	RN55	341392
R5	Resistor, MF	8.87 k Ω 1%	RN55	341391
R6	Resistor, Comp.	15 k Ω 5%	AB-EB	343417
R7	Resistor, Comp.	4.7 k Ω 5%	AB-EB	343365
R8	Resistor, Var.	10 k Ω 10% 0.5 W	Beckman 72XWR10K	311348
S1 through S26	Switch, Pushbutton	MDP-AG	Schadow	465230
CHOPPER PC BOARD ASSEMBLY (A4)				
C1	Capacitor, PP	0.1 μ F 10% 100 V	F-Dyne PP11-.1-100-10	234148
C2	Capacitor, PP	0.1 μ F 10% 100 V	F-Dyne PP11-.1-100-10	234148
IC1	Integrated Circuit	CD4016BE (Selected)	RCA	534223
R1	Not Used			
R2	Not Used			
R3	Resistor, MF	51.1 k Ω 1%	RN55	341468
R4	Resistor, Var.	20 k Ω 10% 0.5 W	Beckman 72PR20K	311354
R5	Resistor, Var.	20 k Ω 10% 0.5 W	Beckman 72PR20K	311354
R6	Resistor, MF	51.1 k Ω 1%	RN55	341468
CONTROL PC BOARD ASSEMBLY (A5)				
BT1	Power Cell	400-SS	Power Conversions Inc.	556005
BT2	Power Cell	400-SS	Power Conversions Inc.	556005

Reference	Description			BEC Part No.
C1	Capacitor, Mica	430 pF 1% 500 V	DM15-431F	200037
C2	Capacitor, Mica	100 pF 5% 500 V	DM15-F101F	200001
C3	Capacitor, Tant.	15 μ F 10% 20 V	Sprague 196D156X9020KA1	283227
C4 through C7	Capacitor, Tant.	6.8 μ F 10% 35 V	Sprague 196D685X9035KA1	283217
CR1	Diode, Sig.	1N914	T.I.	530058
CR2	Diode, LED	IT/F 536024	H.P.	536023
IC1	Integrated Circuit	SN7404N	T.I.	534042
IC2	Resistor Network	4.7 k Ω 2% 1.8 W	AB316B472	345020
IC3	Integrated Circuit	Z80-CPU-PS	Zilog	534159
IC4	Integrated Circuit	SN74LS42N	T.I.	534210
IC5	Integrated Circuit	SN74LS08N	T.I.	534156
IC6	PROM	Programmed 4200-1		534224
IC7	PROM	Programmed 4200-1		534225
IC8	Integrated Circuit	P2114	Intel	534212
IC9	Integrated Circuit	CD4011AE	RCA	534022
IC10	Integrated Circuit	P2114	Intel	534212
IC11	Integrated Circuit	HM3-6501-9	Harris Semiconductor	534213
IC12	Integrated Circuit	HM3-6501-9	Harris Semiconductor	534213
IC13	Resistor Network	4.7 k Ω 2% 1.8 W	AB316B472	345020
IC14	Integrated Circuit	SN74LS42N	T.I.	534210
IC15	Integrated Circuit	SN74LS32N	T.I.	534168
IC16	Integrated Circuit	AM8255APC	Advanced Micro Devices	534171
IC17	Resistor Network	4.7 k Ω 2% 1.8 W	AB316B472	345020
IC18	Integrated Circuit	μ PD8279C-5	Intel	534211
L1	Choke, RF	15 μ H 10%	Gowanda 10/152	400373
Q1	Transistor, NPN	2N3904	Motorola	528071
R1	Resistor, Comp.	330 Ω 5%	AB-EB	343250
R2	Resistor, Comp.	10 k Ω 5%	AB-EB	343400
R3	Resistor, Comp.	10 k Ω 5%	AB-EB	343400
R4	Resistor, Comp.	4.7 k Ω 5%	AB-EB	343365
R5	Resistor, Comp.	5.1 k Ω 5%	AB-EB	343368
R6	Resistor, MF	100 Ω 1%	RN55	341200
R7	Resistor, Comp.	10 k Ω 5%	AB-EB	343400
S1	Switch, Rocker	(8) SPST	Grayhill 76SB08	465225
INPUT PC BOARD ASSEMBLY (A6)				
A1	Op. Amp.	LM301AN	National Semiconductor	535012
A2	Op. Amp.	LM311N	National Semiconductor	535034
A3	Op. Amp.	LM301AN	National Semiconductor	535012
A4	Op. Amp.	CA3140AE	RCA	535050
A5	Op. Amp.	IT/F 535052 (Selected)	National Semiconductor	535062
A6	Op. Amp.	IT/F 535052 (Selected)	National Semiconductor	535062
A7	Op. Amp.	IT/F 535052 (Selected)	National Semiconductor	535079
A8	Op. Amp.	CA3140AE	RCA	535050
A9	Op. Amp.	CA3140AE	RCA	535050
C1	Capacitor, Cer.	33 pF 5% 1 kV	Sprague 10TCC-033	224139
C2	Capacitor, Tant.	6.8 μ F 10% 35 V	Sprague 196D685X9035KA1	283217
C3	Capacitor, Cer.	33 pF 5% 1 kV	Sprague 10TCC-033	224139
C4	Capacitor, PE	0.01 μ F 10% 80 V	Sprague 192P1039R8	234092
C5	Capacitor, Cer.	150 pF 10% 1 kV	Sprague 10TS-T15	224314
C6	Capacitor, Cer.	33 pF 5% 1 kV	Sprague 10TCC-033	224139
C7	Capacitor, Cer.	33 pF 5% 1 kV	Sprague 10TCC-033	224139
C8	Capacitor, Cer.	1000 pF 10% 1 kV	Sprague 10TS-D10	224310
C9	Capacitor, Mica	1500 pF 1% 500 V	Cornell-Dubilier CD19FD152F-03	200531
C10	Not Used			
C11	Not Used			
C12	Capacitor, Cer.	0.01 μ F 100 V	Erie 805-000X5V0103Z	224119
C13	Capacitor, Cer.	68 pF 10% 1 kV	Sprague 10TS-Q68	224312

Section V
Parts List

TABLE OF REPLACEABLE PARTS (Cont.)

Reference	Description	BEC Part No.
INPUT P.C. BOARD ASSEMBLY (A6)		
C14	Capacitor, PE 0.01 μ F 10% 80 V	Sprague 192P1039R8 234092
C15	Capacitor, Cer. 0.01 μ F 100 V	Erie 805-000X5V0103Z 224119
C16	Capacitor, Cer. 68 pF 10% 1 kV	Sprague 10TS-068 224312
C17	Capacitor, Cer. 2200 pF 10% 250 V	Sprague 2SS-D22 224309
C18	Capacitor, PE 0.01 μ F 10% 80 V	Sprague 192P1039R8 234092
C19	Capacitor, Cer. 330 pF 10% 1 kV	Sprague 10TSS-TT33 224313
C20	Capacitor, PP 0.1 μ F 10% 100 V	F-Dyne PP11-.1-100-10 234148
C21	Not Used	
C22	Capacitor, PP 0.1 μ F 10% 100 V	F-Dyne PP11-.1-100-10 234148
C23	Capacitor, Cer. 33 pF 5% 1 kV	Sprague 10TCC-Q33 224139
C24	Capacitor, Cer. 1000 pF 10% 1 kV	Sprague 10TS-D10 224310
C25	Capacitor, Cer. 33 pF 5% 1 kV	Sprague 10TCC-Q33 224139
C26	Capacitor, Cer. 1000 pF 10% 1 kV	Sprague 10TS-D10 224310
C27	through	
C34	Capacitor, Tant. 6.8 μ F 10% 35 V	Sprague 196D68SX9035KA1 283217
C35	Capacitor, Cer. 150 pF 10% 1 kV	Sprague 10TS-T15 224314
C36	Capacitor, Elec. 100 μ F 20% 25 V	United-Chemicon SM25-VB100M 283334
IC1	Integrated Circuit AM8255APC	Advanced Micro Devices 534171
IC2	Op. Amp. AD565JN/BIN	Analog Devices 421034
IC3	Integrated Circuit CD4053BE	RCA 534207
IC4	Not Used	
IC5	Integrated Circuit CD4047AE	RCA (ONLY) 534229
IC6	Integrated Circuit CD4051BE	RCA (ONLY) 534209
IC7	Integrated Circuit CD4013BE	RCA (ONLY) 534205
IC8	Integrated Circuit CD4013BE	RCA (ONLY) 534205
IC9	Integrated Circuit CD4016BE	RCA (ONLY) 534218
IC10	Integrated Circuit CD4016BE	RCA (ONLY) 534218
IC11	Integrated Circuit CD4075BE	RCA 534206
IC12	Resistor Network 47 k Ω 2% 1.6 W	AB314B473 345019
IC13	Integrated Circuit CD4051BE	RCA (ONLY) 534209
IC14	Integrated Circuit CD4051BE	RCA (ONLY) 534209
R1	Resistor, Var. 100 Ω 10% 0.5 W	Beckman 72PR100 311408
R2	Resistor, Comp. 2.7 k Ω 5%	AB-EB 343341
R3	Resistor, Comp. 1 k Ω 5%	AB-EB 343300
R4	Resistor, Comp. 100 Ω 5%	AB-EB 343200
R5	Resistor, MF 10.0 k Ω 1%	RN55 341400
R6	Resistor, MF 5.11 k Ω 1%	RN55 341368
R7	Resistor, MF 9.09 k Ω 1%	RN55 341392
R8	Resistor, MF 1.0 k Ω 1%	RN55 341300
R9	Resistor, MF 10.0 k Ω 1%	RN55 341400
R10	Resistor, Comp. 3 M Ω 5%	AB-EB 343646
R11	Resistor, Var. 50 k Ω 10% 0.5 W	Beckman 72PR50K 311393
R12	Resistor, MF 1.0 M Ω 1%	RN55 341600
R13	Resistor, MF 1.0 M Ω 1%	RN55 341600
R14	Resistor, MF 237 k Ω 1%	RN55 341536
R15	Resistor, MF 249 k Ω 1%	RN55 341538
R16	Resistor, MF 12.1 k Ω 1%	RN55 341408
R17	Resistor, MF 806 k Ω 1%	RN55 341587
R18	Resistor, Comp. 10 M Ω 5%	AB-EB 343700
R19	Resistor, Comp. 10 M Ω 5%	AB-EB 343700
R20	Resistor, MF 1.82 k Ω 1%	RN55 341325
R21	Resistor, MF 20.0 k Ω 1%	RN55 341429
R22	Resistor, MF 221 k Ω 1%	RN55 341533
R23	Resistor, MF 1.0 M Ω 1%	RN55 341600
R24	Resistor, Var. 25 k Ω 10% 0.5 W	Beckman 72PR25K 311400
R25	Resistor, MF 1.0 M Ω 1%	RN55 341600
R26	through	
R28	Resistor, MF 100.0 k Ω 1%	RN55 341500
R29	Resistor, MF 54.9 k Ω 1%	RN55 341471
R30	Resistor, MF 100.0 k Ω 1%	RN55 341500
R31	Resistor, MF 54.9 k Ω 1%	RN55 341471
R32	Resistor, MF 9.09 k Ω 1%	RN55 341392
R33	Resistor, MF 2.10 k Ω 1%	RN55 341331
R34	Resistor, Comp. 10 k Ω 5%	AB-EB 343400
R35	Resistor, Comp. 5.1 k Ω 5%	AB-EB 343368
R36	Resistor, Var. 10 k Ω 10% 0.5 W	Beckman 72PR10K 311328
R37	Resistor, Comp. 3.9 k Ω 5%	AB-EB 343357
R38	Resistor, MF 7.87 k Ω 1%	RN55 341386
R39	Resistor, MF 80.6 k Ω 1%	RN55 341487
R40	Resistor, MF 806 k Ω 1%	RN55 341587
R41	Not Used	

Reference	Description	BEC Part No.
R42	Resistor, Comp. 7.5 k Ω 5%	AB-EB 343384
R43	Not Used	
R44	Resistor, Var. 200 k Ω 10% 0.5 W	Beckman 72PR200K 311401
R45	Resistor, Var. 10 k Ω 10% 0.5 W	Beckman 72PR10K 311328
R46	Not Used	
R47	Resistor, Comp. 3.9 k Ω 5%	AB-EB 343357
R48	Resistor, MF 909 k Ω 1%	RN55 341592
RT1	Thermistor 50 Ω 10%	Fenwal LB15J1 325007
POWER SUPPLY PC BOARD		
A1	Op. Amp. LM339N	National Semiconductor 535018
C1	Capacitor, Elec. 800 μ F +75/-10% 50 V Mallory	CG801U050R2C3PH 283347
C2	Capacitor, Elec. 800 μ F +75/-10% 50 V Mallory	CG801U050R2C3PH 283347
C3	Capacitor, Elec. 4500 μ F +75/-10% 25 V	GE 86F537M 283318
C4	Capacitor, Elec. 10 μ F 20% 25 V	United Chemicon SM-25VB-10M 283336
C5	Capacitor, Elec. 100 μ F 20% 16 V	United Chemicon SM-16VB-100M 283337
C6	Capacitor, Elec. 100 μ F 20% 16 V	United Chemicon SM-16VB-100M 283337
C7	Capacitor, Elec. 1000 μ F +50/-10% 10 V	Sprague 503D108F010PE 283329
C8	Capacitor, Cer. 3300 pF 10% 100 V	Kemet C052C332K1X5CA 224296
C9	Capacitor, Elec. 100 μ F 20% 16 V	United Chemicon SM-16VB-100M 283337
CR1	Diode, Bridge KP8-02	General Inst. 532013
CR2	Diode, Bridge VS-248	Varo 532014
CR3	through	
CR6	Diode, Sil. IN4001	Motorola 530151
IC1	Voltage Regulator μ A7805UC	Fairchild 535011
IC2	Voltage Regulator μ A78MGUIC (Modified)	Fairchild 535058
IC3	Voltage Regulator μ A79MGUIC (Modified)	Fairchild 535087
IC4	Voltage Regulator μ A78GUIC (Modified)	Fairchild 535059
IC5	Voltage Regulator μ A79MGUIC (Modified)	Fairchild 535087
IC6	Integrated Circuit CD4013BE	RCA 534205
P1	Conn. Header 5 Pin	Panduit HPSS156-5-C 477345
P4	Conn. Header 6 Pin	Molex 22-04-2061 477327
P5	Conn. Header 6 Pin	Molex 22-04-2061 477327
P7	through	
P10	Conn. Header 6 Pin	Molex 22-04-2061 477327
R1	Resistor, MF 10.0 k Ω 1%	RN55 341400
R2	Resistor, MF 4.99 k Ω 1%	RN55 341367
R3	Resistor, MF 2.21 k Ω 1%	RN55 341333
R4	Resistor, MF 12.7 k Ω 1%	RN55 341410
R5	Resistor, Var. 500 Ω 10% 0.5 W	Beckman 72PR500 311305
R6	through	
R8	Resistor, MF 4.99 k Ω 1%	RN55 341367
R9	Resistor, Comp. 1 k Ω 5%	AB-EB 343300
R10	Resistor, MF 453 Ω 1%	RN55 341263
R11	Resistor, Var. 100 Ω 10% 0.5 W	Beckman 72PR100 311408
R12	Resistor, MF 464 Ω 1%	RN55 341264
R13	Resistor, Comp. 100 k Ω 5%	AB-EB 343500
R14	Resistor, Comp. 330 Ω 5% 1 W	AB-GB 302087
R15	Resistor, Comp. 5.1 k Ω 5%	AB-EB 343368
R16	Resistor, MF 2.21 k Ω 1%	RN55 341333
R17	Resistor, MF 2.80 k Ω 1%	RN55 341343
R18	Resistor, Comp. 5.1 k Ω 5%	AB-EB 343368
R19	Resistor, Comp. 51 k Ω 5%	AB-EB 343468

TABLE OF REPLACEABLE PARTS (Cont.)

Reference	Description	BEC Part No.
MISCELLANEOUS		
	Cable Assembly (P.S. to Display)	571142
	Cable Assembly (P.S. to Input)	571143
	Cable Assembly (P.S. to Control 1)	571144
	Cable Assembly (P.S. to Control 2)	571145
	Cable Assembly (P.S. to Interface)	571147
	Cable Assembly (Control to Display)	920046
	Cable Assembly (Control to Input)	920050
INTERFACE PC BOARD ASSEMBLY (-01 OPTION)		
C1	Capacitor, Tant. 10 μ F 20% 25 V	Sprague 196D106X0025KA1 283293
C2	Capacitor, Tant. 10 μ F 20% 25 V	Sprague 196D106X0025KA1 283293
C3	Capacitor, Cer. 1000 pF 10% 1 kV	Sprague 10TS-D10 224310
CR1	Diode, Sil. 1N914	T.I. 530058
IC1	PROM Programmed 4200-1	Boonton Electronics 534260
IC2	Resistor Network 3.3 k Ω 2% 2 W	Beckman 784-1-R3.3K 345017
IC3	Integrated Circuit AM8255APC	Advanced Micro Devices 534171
IC4	Integrated Circuit SN74LS00N	T.I. 534167
IC5	Integrated Circuit SN74LS04N	T.I. 534155
IC6	Integrated Circuit SN7402N	T.I. 534027
IC7	Integrated Circuit SN74LS74N	T.I. 534157
IC8	Integrated Circuit N8T26AN	Signetics 534097
IC9	Integrated Circuit N8T26AN	Signetics 534097
IC10	Integrated Circuit SN7438N	T.I. 534108
IC11	Resistor Network 3 k Ω /6.2 k Ω 5% 2 W	National Semiconductor RA28-3K/6.2KN 345016
IC12	Resistor Network 3 k Ω /6.2 Ω 5% 2 W	National Semiconductor RA28-3K/6.2KN 345016
J1	Connector 24 Pin	AMP 552230-1 479350
R1	Resistor, Comp. 5.1 k Ω 5%	AB-EB 343368
S1	Switch, Slide 7 Sw. Sections	CTS-206-7 475215
MISCELLANEOUS (-01 OPTION)		
	Cable Assembly (Input 1, Input 2, Control, and Interface)	Boonton Electronics 920052
	Cable Assembly 1m Long HP10631	HP-IB 571133
2ND INPUT CHANNEL (-03 OPTION)		
(See Input PC Board Assembly Parts List)		
CHOPPER PC BOARD ASSEMBLY (-03 OPTION)		
(See Chopper PC Board Assembly Parts List)		
MISCELLANEOUS (-03 OPTION)		
	Cable Assembly (P.S. to MPX)	Boonton Electronics 042316

SECTION VI

SCHEMATIC DIAGRAMS

E831271A

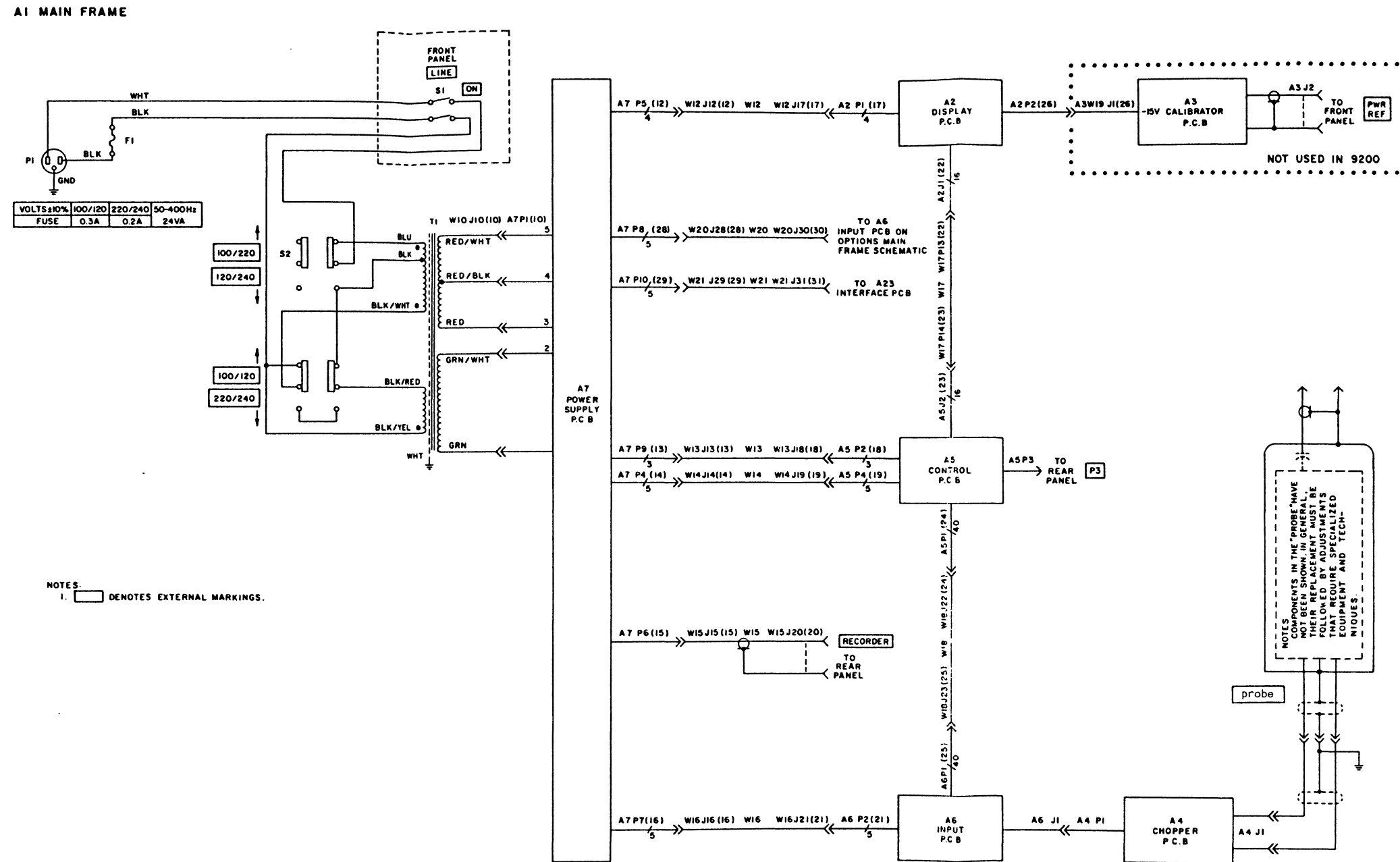
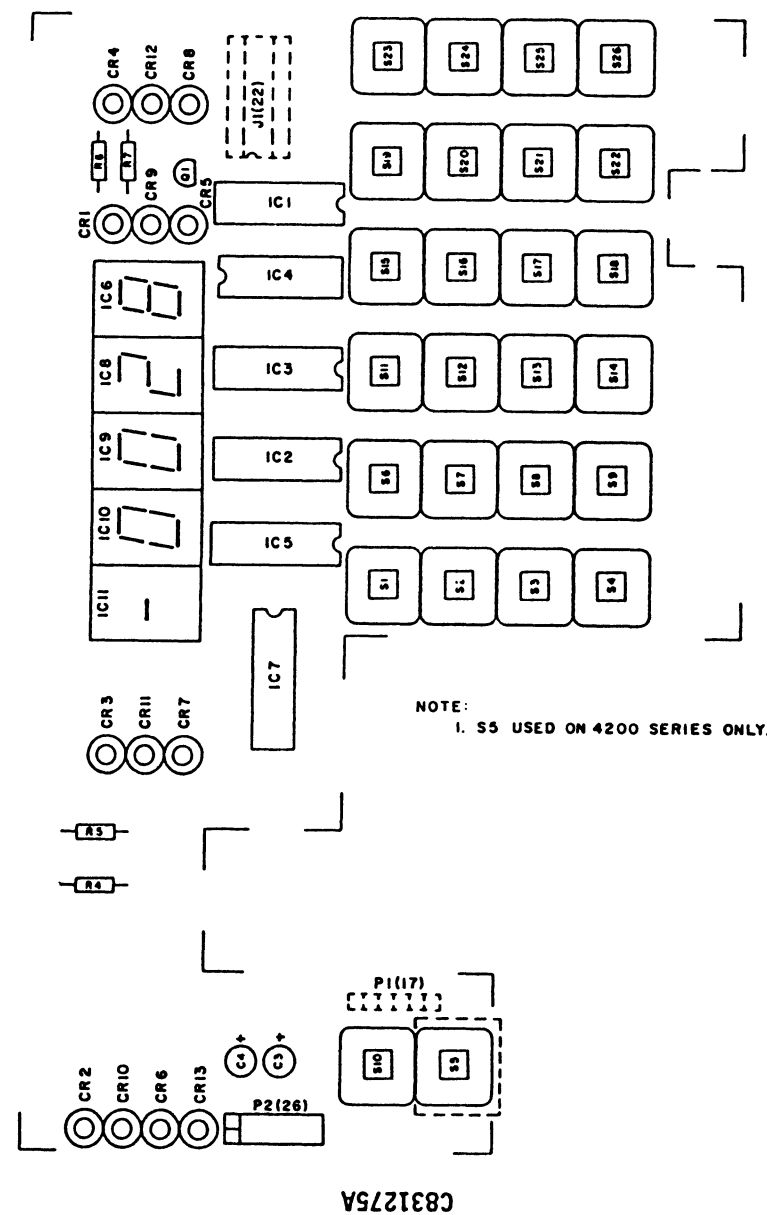
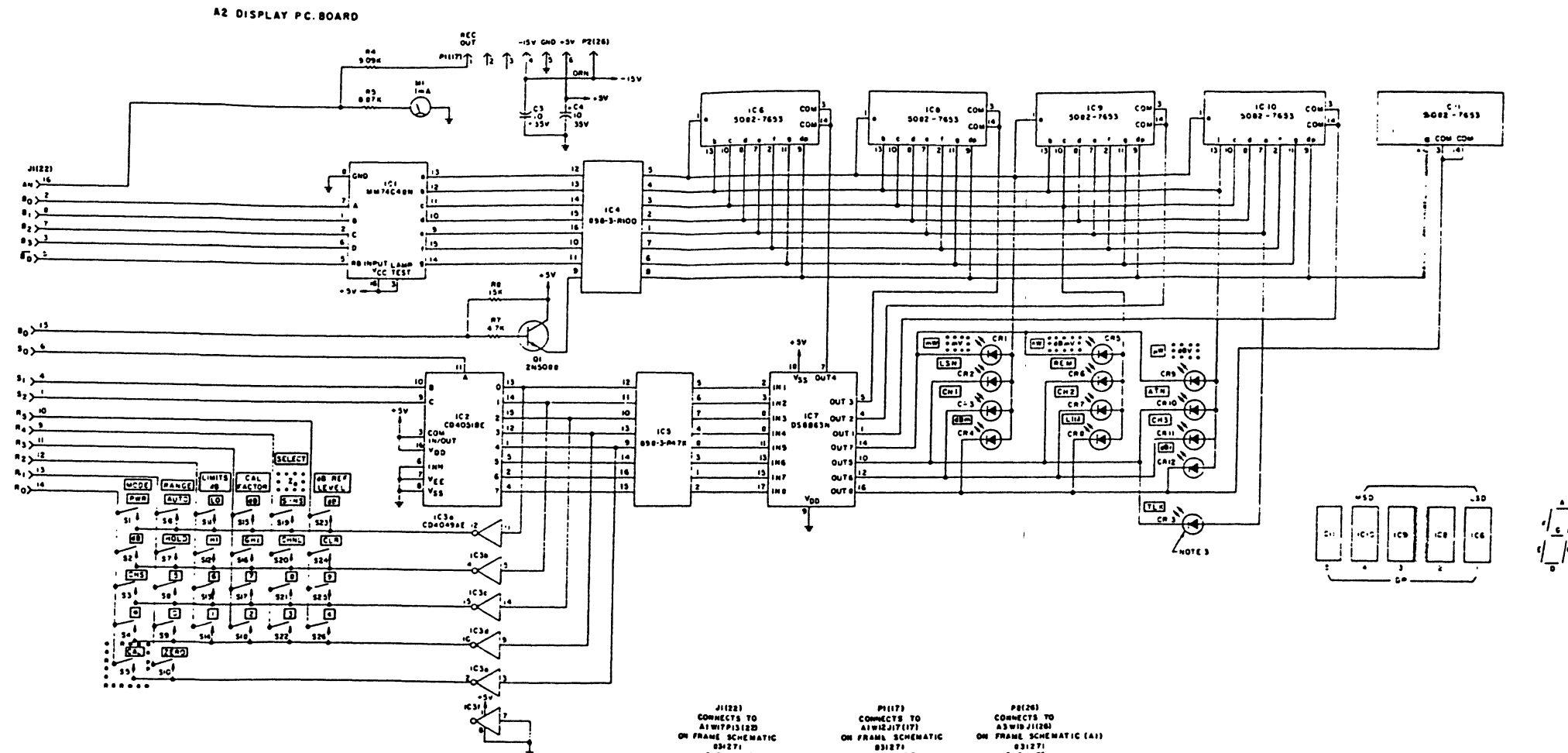

Figure 6-1 Main Frame A1, Schematic Diagram

Section VI
Schematic Diagrams



E831271A



- NOTES
1. CAPACITANCE VALUES IN μ F UNLESS OTHERWISE SPECIFIED
 2. RESISTANCE VALUE IN OHMS UNLESS OTHERWISE SPECIFIED
 3. ALL LED'S TO BE TYPE HLMP-1301 UNLESS OTHERWISE SPECIFIED
 4. [Symbol] EXTERNAL MARKINGS.
 5. [Symbol] USED ON 9200 SERIES ONLY.
 6. LAST NUMBERS USED
RB CR13 326 IC11
 7. [Symbol] USE D ON 4200 SERIES ONLY.

J11221
CONNECTS TO
A1W1P13122
ON FRAME SCHEMATIC
831271
SHT.1 OF 7

P11173
CONNECTS TO
A1W1P13122
ON FRAME SCHEMATIC
831271
SHT.1 OF 7

P81261
CONNECTS TO
A3W1P13126
ON FRAME SCHEMATIC (A1)
831271
SHT.1 OF 7

Figure 6-2 Display Board A2, Schematic Diagram

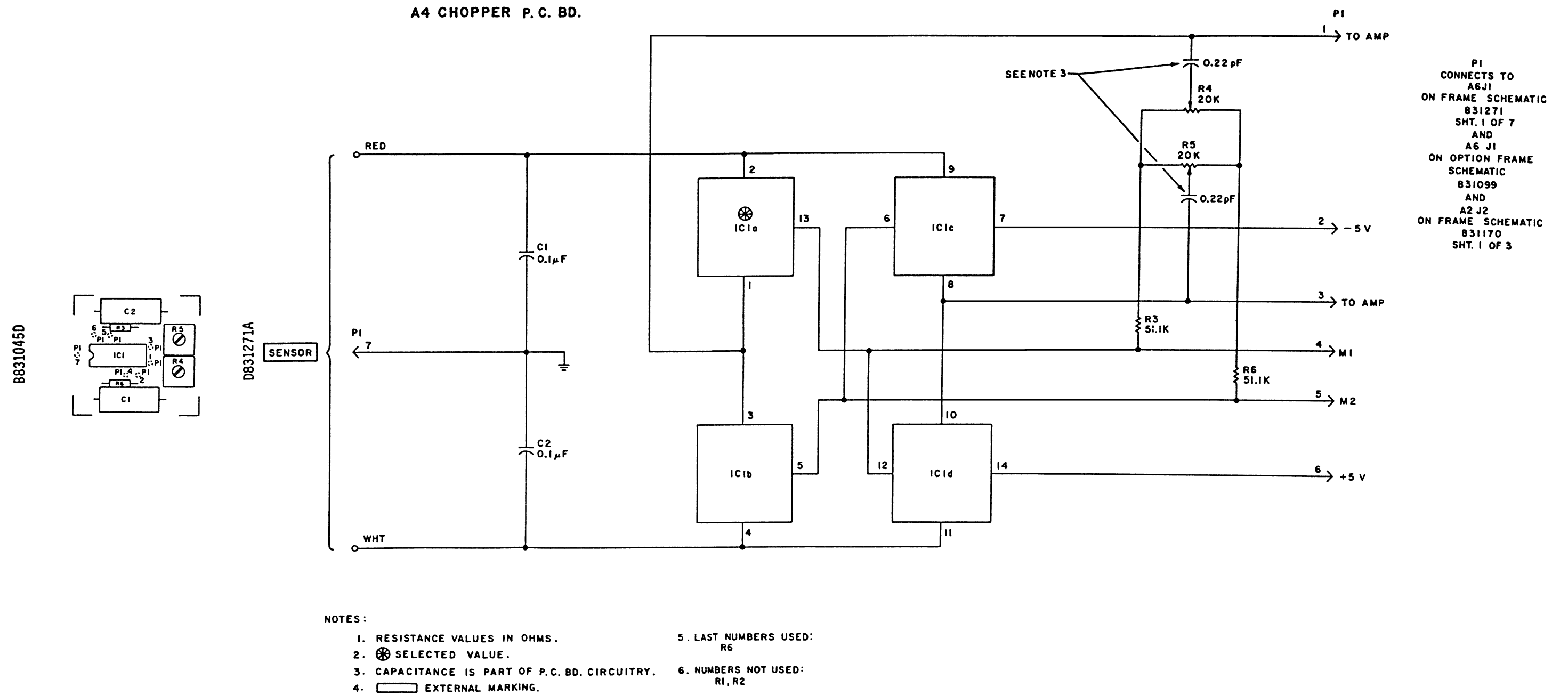

Figure 6-3 Chopper Board A4, Schematic Diagram

Section VI
Schematic Diagrams

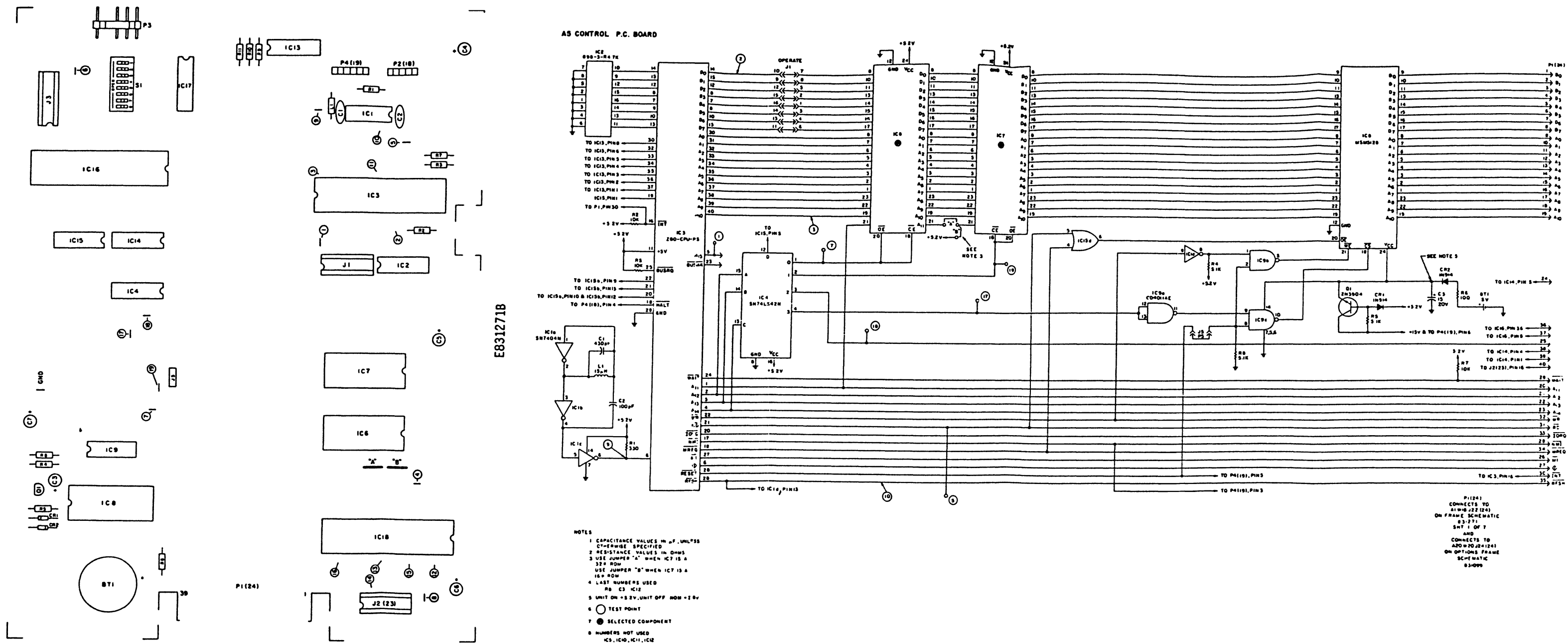
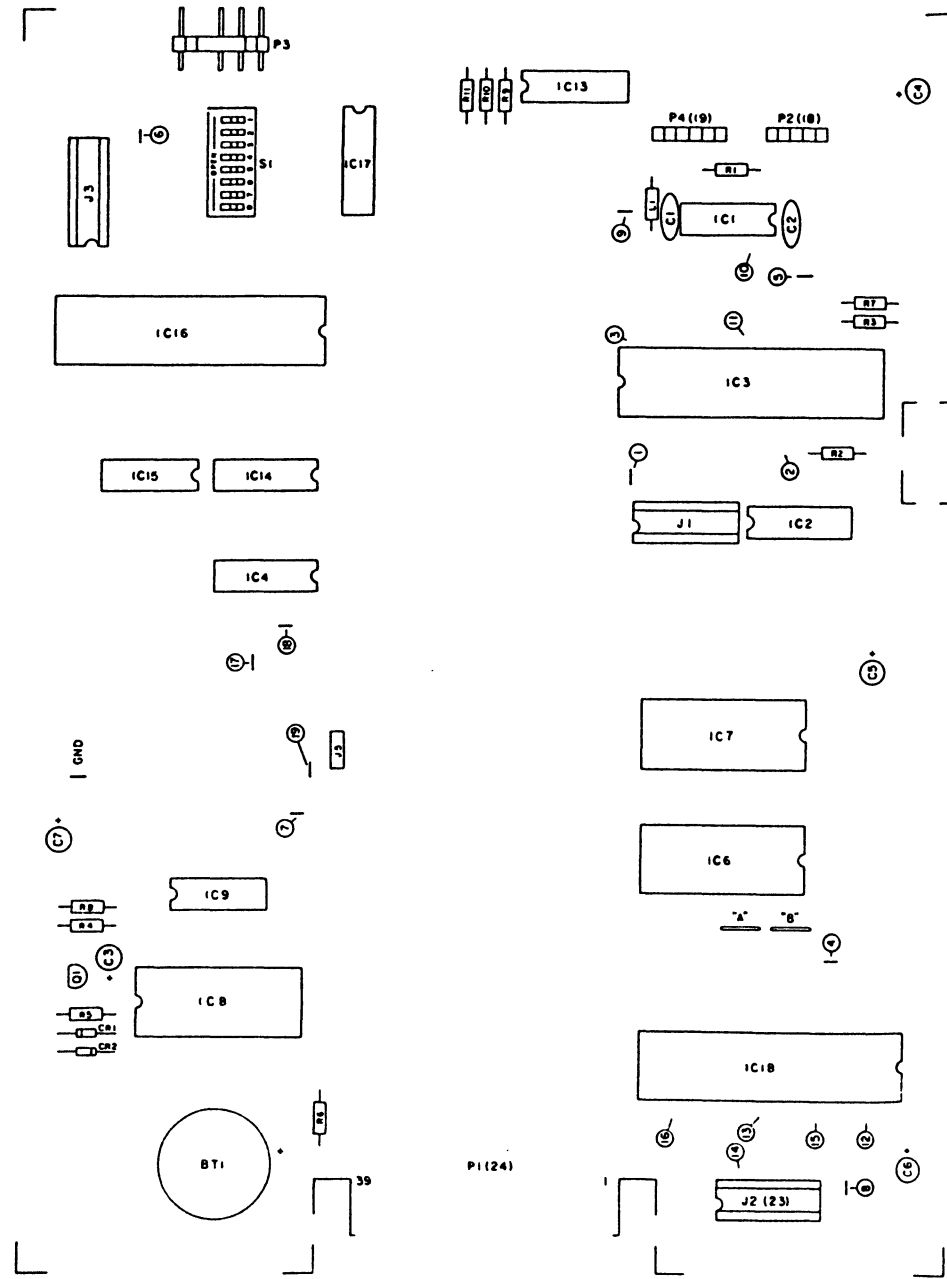

Figure 6-4 Control Board A5, Schematic Diagram
(Sheet 1 of 2)

D831299A



D831271B

A5 CONTROL P.C. BOARD

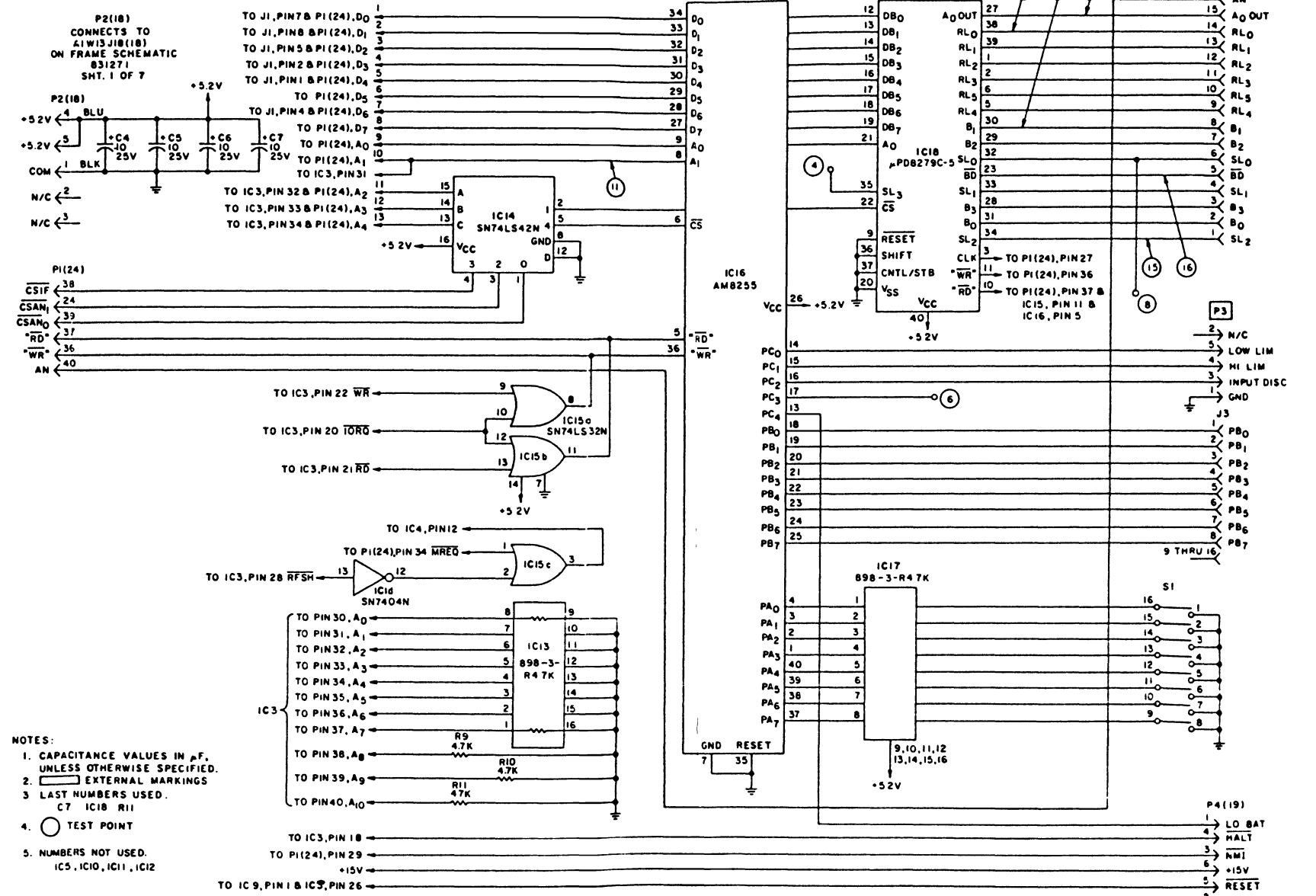
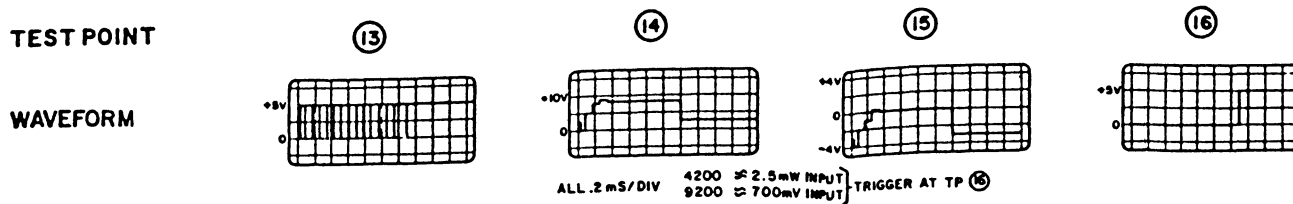
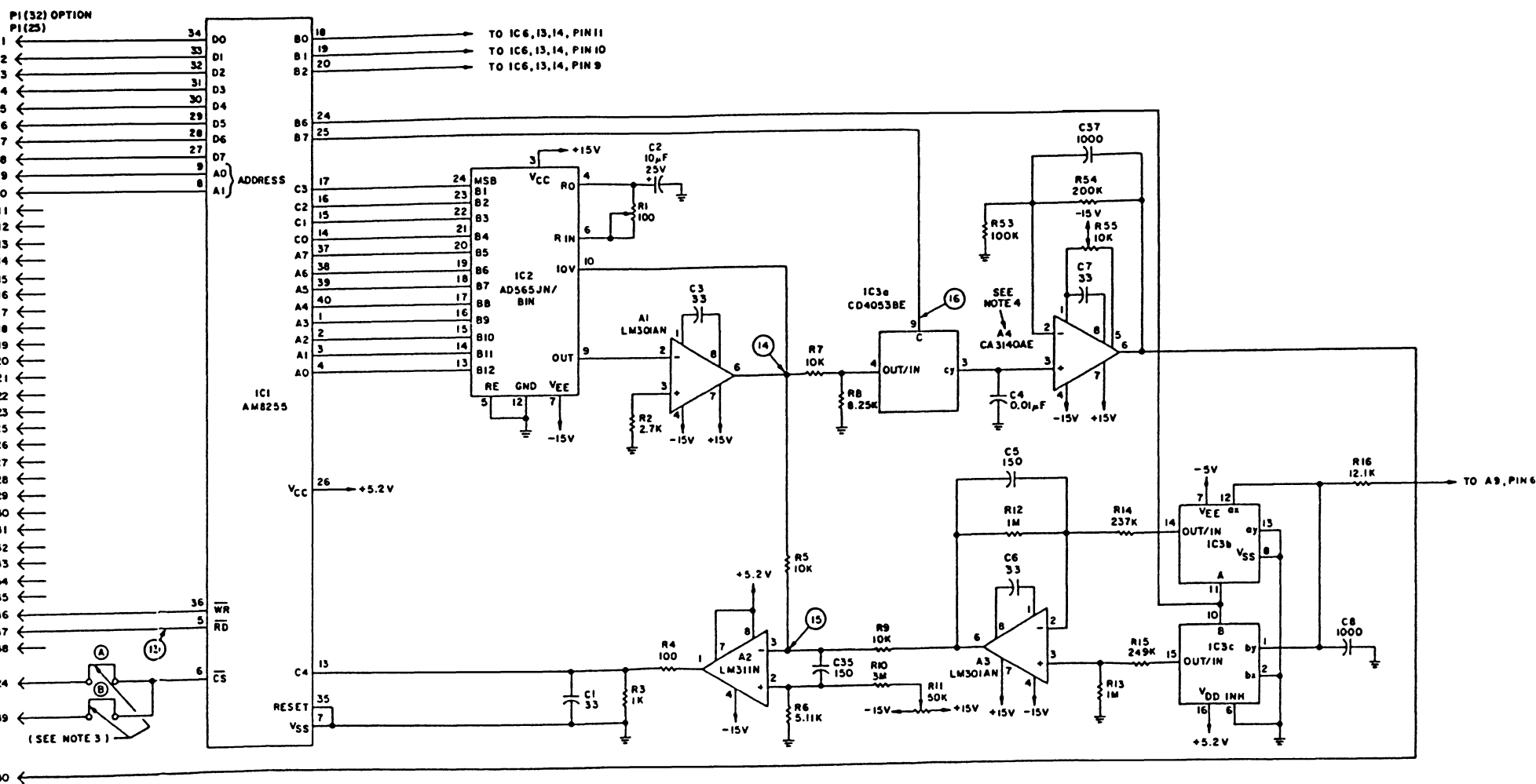

Figure 6-4 Control Board A5, Schematic Diagram (Sheet 2 of 2)



A6 INPUT MODULE P.C. BD.



- NOTES
1. CAPACITANCE VALUES IN pF, UNLESS OTHERWISE SPECIFIED.
 2. RESISTANCE VALUES IN OHMS, UNLESS OTHERWISE SPECIFIED.
 3. CHANNEL 1 ADD JUMPER (B) ONLY. CHANNEL 2 ADD JUMPER (A). REMOVE (B).
 4. A4 NOT USED ON CHANNEL 2.
 5. ○ TEST POINT.
- PI(25) CONNECTS TO A1W8 J23(25) ON FRAME SCHEMATIC #31271 SHT. 1 OF 7
- PI(32) CONNECTS TO A20W20 J29(32) ON OPTION FRAME SCHEMATIC #31099

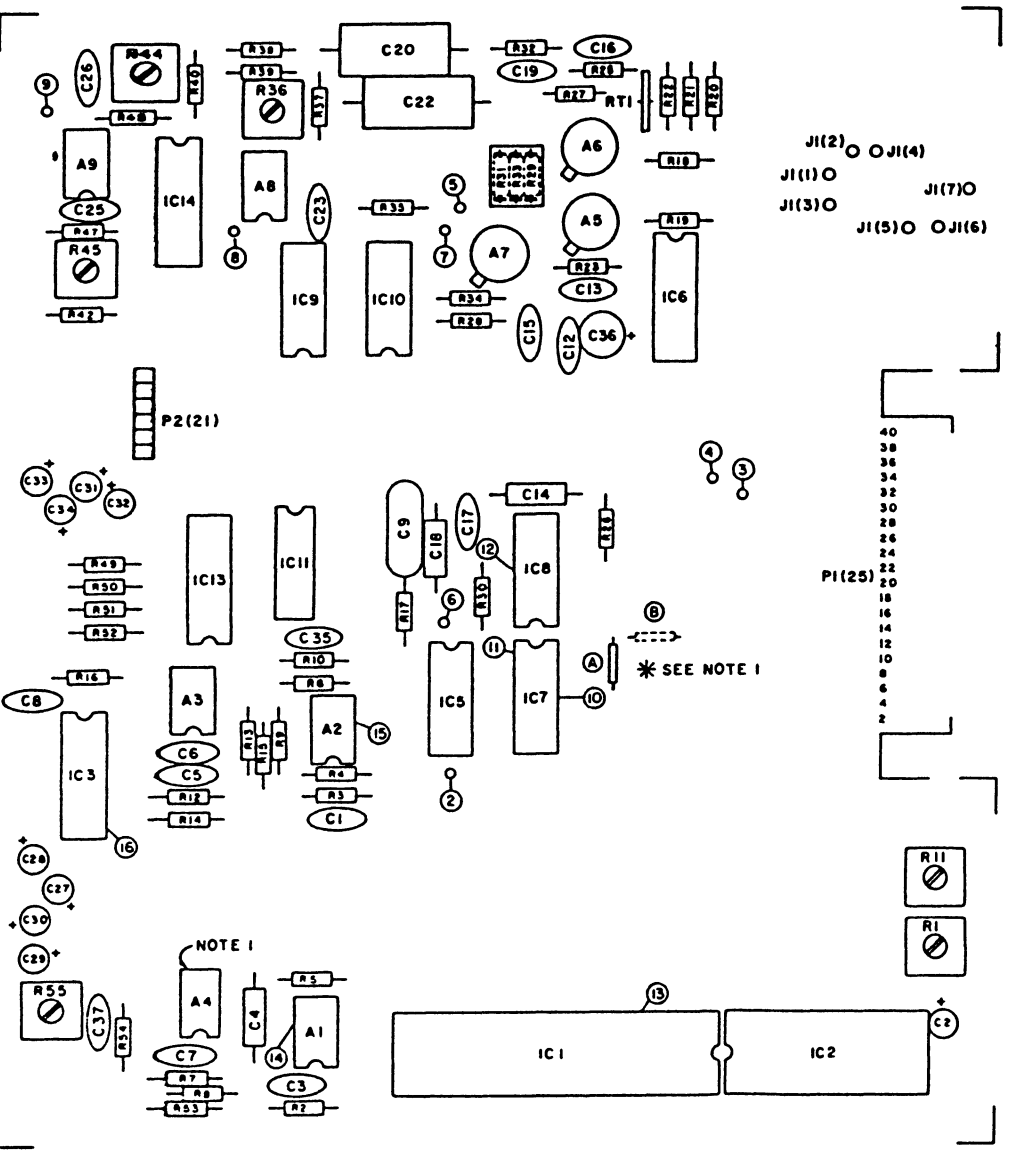

- NOTES
1. * CHANNEL 1 ADD JUMPER (B). CHANNEL 2 ADD JUMPER (A). REMOVE (B) & A4 AMPLIFIER.

Figure 6-5 Input Module Board A6,
Schematic Diagram (Sheet 1 of 2)

C831273A

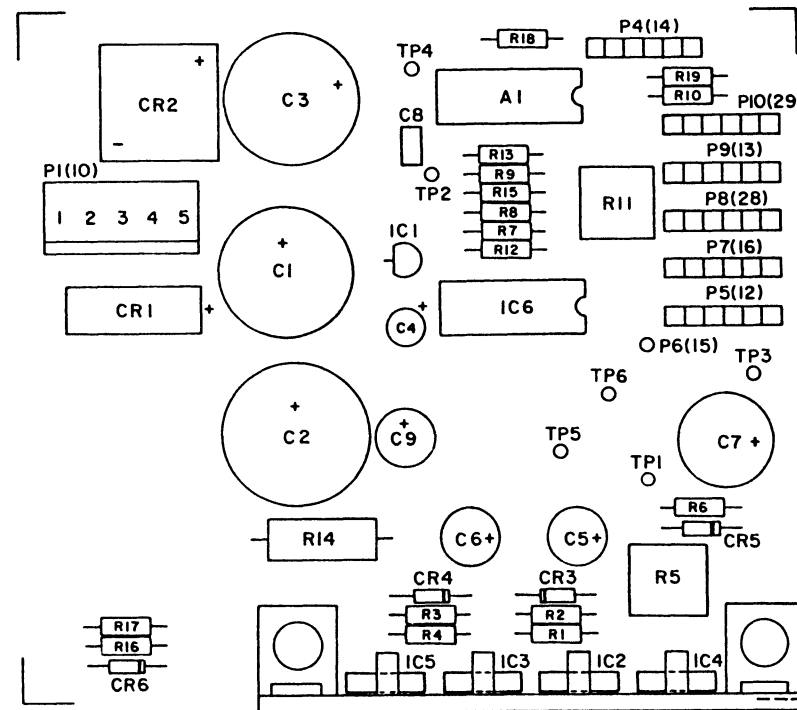

A7 POWER SUPPLY P.C. BD.

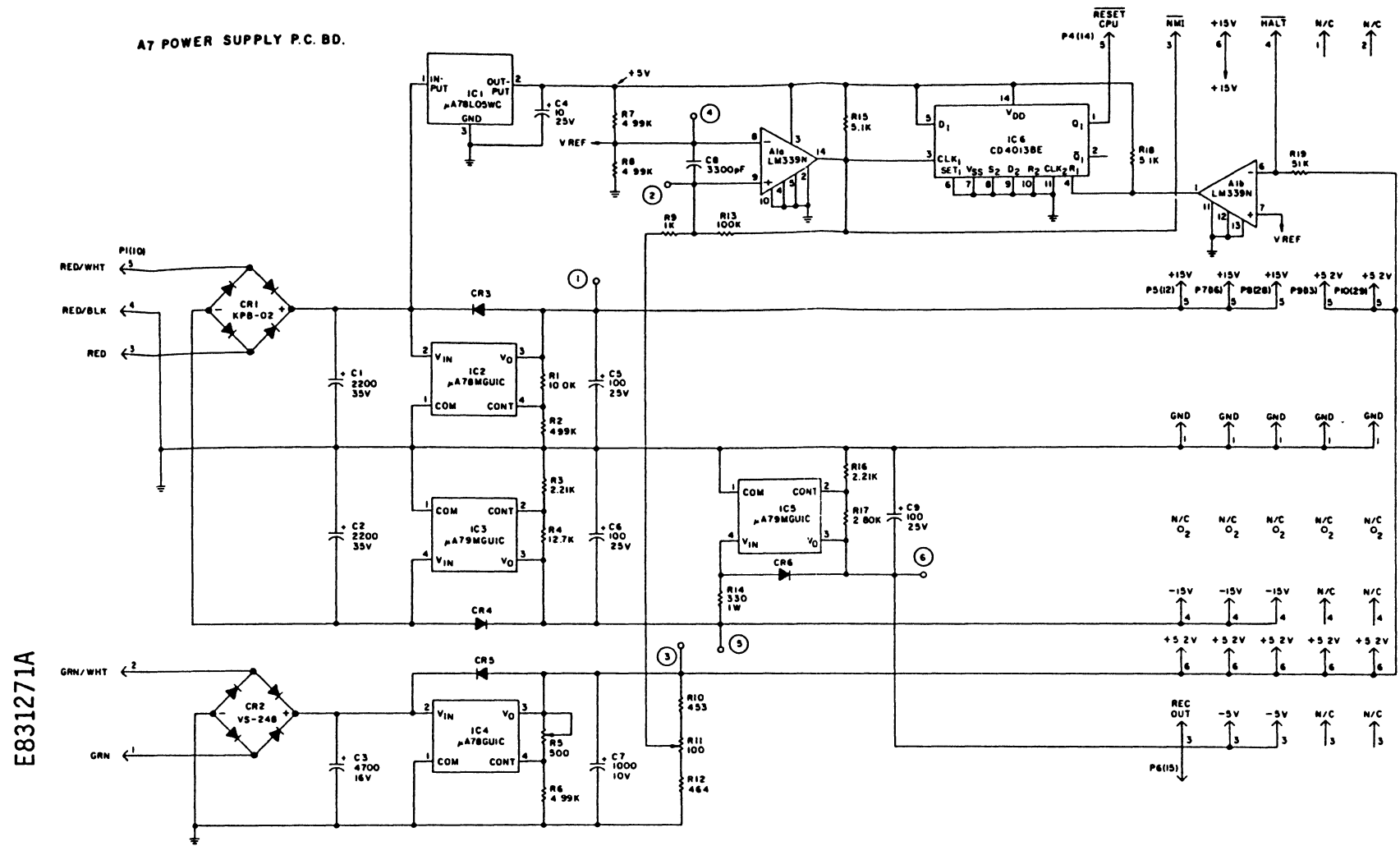

E831271A

- NOTES:
- 1 ALL CAPACITANCE VALUES IN μ F, UNLESS OTHERWISE SPECIFIED
 - 2 ALL RESISTANCE VALUES IN OHMS.
 - 3 ○ TEST POINT
 - 4 LAST NUMBERS USED.
R18 C9
 - 5 NUMBERS NOT USED.
P2 P3

P1 (10)
CONNECTS TO
A1 J10 (10)
ON FRAME SCHEMATIC
831271
SHT 1 OF 7

P4 (14)
CONNECTS TO
A1 W14 J14 (14)
ON FRAME SCHEMATIC
831271
SHT 1 OF 7

P5 (12)
CONNECTS TO
A1 W12 J12 (12)
ON FRAME SCHEMATIC
831271
SHT 1 OF 7

P6 (15)
CONNECTS TO
A1 W15 J15 (15)
ON FRAME SCHEMATIC
831271
SHT 1 OF 7

P7 (16)
CONNECTS TO
A1 W16 J16 (16)
ON FRAME SCHEMATIC
831271
SHT 1 OF 7

P8 (28)
CONNECTS TO
A1 W20 J20 (28)
ON FRAME SCHEMATIC
831271
SHT 1 OF 7

P9 (13)
CONNECTS TO
A1 W13 J13 (13)
ON FRAME SCHEMATIC
831271
SHT 1 OF 7

P10 (29)
CONNECTS TO
A1 W21 J21 (29)
ON FRAME SCHEMATIC
831271
SHT 1 OF 7

Figure 6-6 Power Supply Board A7,
Schematic Diagram

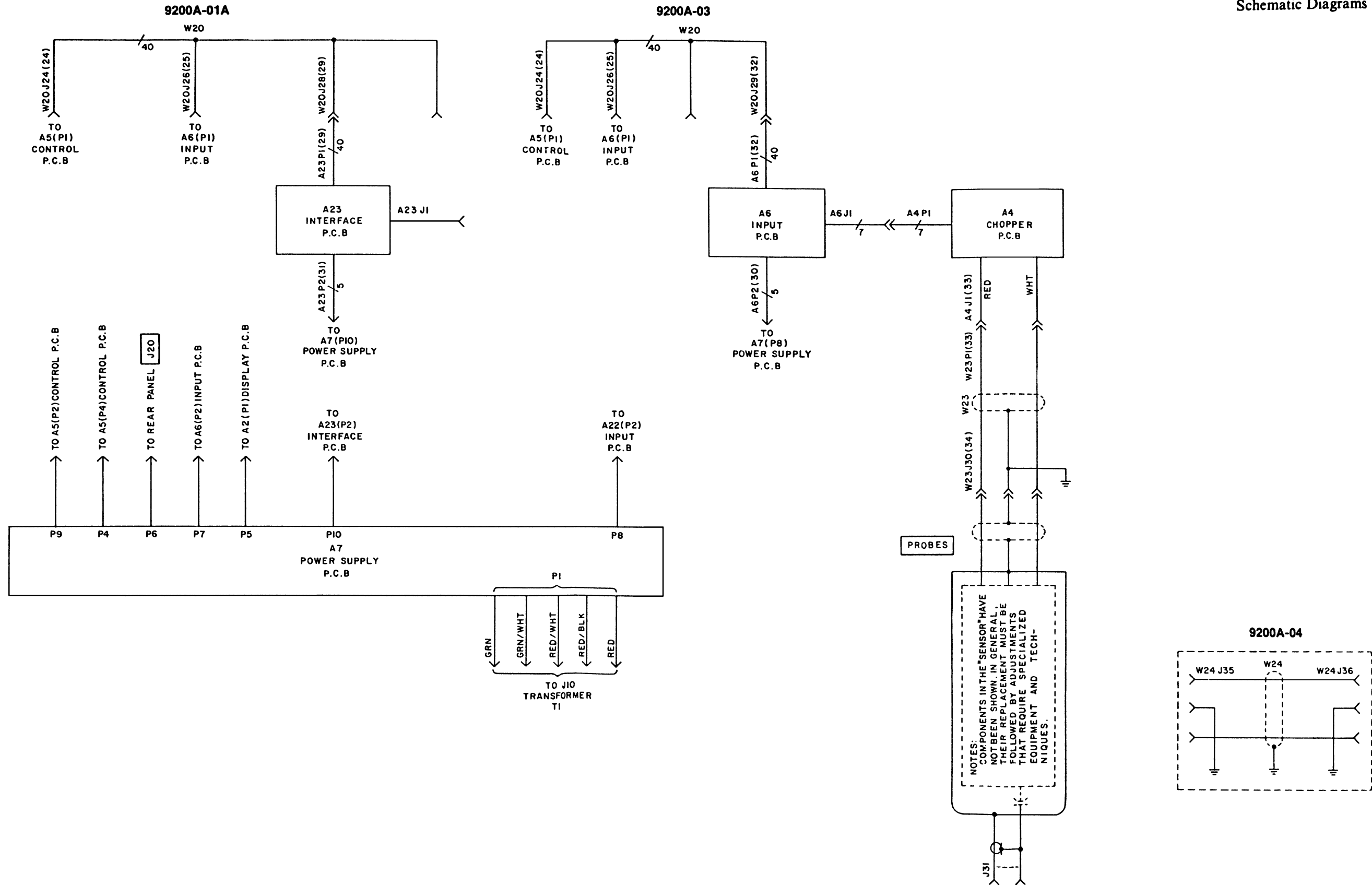

Figure 6-7 Options, Schematic Diagram

APPENDIX A

IEEE-488 BUS INTERFACE

OPTION 9200A-01A

A-1. DESCRIPTION.

A-2. The IEEE-488 (GPIB) bus interface option permits external control of the instrument and data capture by a wide variety of compatible controllers. The instrument may be operated with other GPIB-compatible devices to achieve specific test automation goals, with no specialized control interface requirements for proper electrical operation.

A-3. Although no standard GPIB interface data formats have yet been established, certain common practices are achieving de-facto standard status. These practices have been adhered to in the design of the 9200A-01A option interface formats and delimiters, thereby assuring the user of format compatibility with almost all controllers.

A-4. CAPABILITY.

A-5. Certain subsets of full GPIB functions are specified in the IEEE-488 1975 Standard. The Model 9200A-01A option includes the following capabilities:

SH1 SOURCE HANDSHAKE complete capability
AH1 ACCEPTOR HANDSHAKE complete capability
T6 BASIC TALKER, SERIAL POLL, UNADDRESS IF MLA, NO TALKER ONLY capability
TE0 NO EXTENDED TALKER capability
L4 BASIC LISTENER, UNADDRESS IF MTA, NO LISTENER ONLY capability
LE0 NO EXTENDED LISTENER capability
SR1 SERVICE REQUEST capability
RL2 REMOTE-LOCAL capability, NO LOCAL LOCKOUT
PP0 NO PARALLEL POLL capability
DC0 NO DEVICE CLEAR capability
DT1 DEVICE TRIGGER capability
C0 NO CONTROLLER capability

NOTE

MLA = My Listen Address
MTA = My Talk Address

A-6. INSTALLATION.

A-7. Option 9200A-01A consists of interface board A23. Electrical interconnections are shown in Figure 6-7. To install the interface board, proceed as follows:

- a. Turn off power to the instrument.
- b. Remove the screw that secures the top cover of the instrument and slide the top cover back and off.
- c. Remove the screws that attach the upper rear panel cover plate of the instrument and remove the rear panel cover plate.
- d. Cut the *cable tie* in the instrument that holds the extra brown power plug (the plug with two blue wires and one black wire).
- e. Remove the six screws that fasten the control board and replace them with the six mounting posts supplied with the -01A package.
- f. Position the interface board in the instrument so that the mounting holes in the interface board line up with the mounting posts in the instrument. Attach the interface board to the mounting posts with six 4-40 screws and lockwashers supplied with the interface board.
- g. Unplug the 40-pin connectors from the control and input printed circuit boards in the instrument and remove the 40-conductor bus cable from the instrument. Install the new 40-conductor bus cable supplied with the interface board. Note that the new bus cable has four 40-pin connectors. Install the new bus cable so that the end with the three adjacent connectors is uppermost. The 40-pin connector at the lower end of the bus cable is for connection to a second input printed circuit board. If the instrument is equipped with option 9200A-03, connect this connector to the second input printed circuit board; if the instrument is not equipped with option 9200A-03, leave this connector unconnected. Connect the other three connectors on the bus cable to the input, control, and interface printed circuit boards, respectively.
- h. Connect the brown power plug in the instrument to the 4-pin brown connector on the interface board.

A-8. OPERATION.

A-9. Address Assignment. Before using the instrument in the GPIB, it must be assigned a unique address. This address is set using the five right-most sections of rear-panel address switch S1 in accordance with table A-1.

TABLE A-1. ADDRESS ASSIGNMENT

*Decimal Address	Talk Code	Listen Code	Switch Setting				
			5	4	3	2	1
0	@	SP	0	0	0	0	0
1	A	!	0	0	0	0	1
2	B	"	0	0	0	1	0
3	C	#	0	0	0	1	1
4	D	\$	0	0	1	0	0
5	E	%	0	0	1	0	1
6	F	&	0	0	1	1	0
7	G	'	0	0	1	1	1
8	H	(0	1	0	0	0
9	I)	0	1	0	0	1
10	J	*	0	1	0	1	0
11	K	+	0	1	0	1	1
12	L	,	0	1	1	0	0
13	M	-	0	1	1	0	1
14	N	.	0	1	1	1	0
15	O	/	0	1	1	1	1
16	P	0	1	0	0	0	0
17	Q	1	1	0	0	0	1
18	R	2	1	0	0	1	0
19	S	3	1	0	0	1	1
20	T	4	1	0	1	0	0
21	U	5	1	0	1	0	1
22	V	6	1	0	1	1	0
23	W	7	1	0	1	1	1
24	X	8	1	1	0	0	0
25	Y	9	1	1	0	0	1
26	Z	:	1	1	0	1	0
27	[;	1	1	0	1	1
28	\	<	1	1	1	0	0
29]	=	1	1	1	0	1
30	^	>	1	1	1	1	0

*Address 31 (11111) will not be recognized and should not be used.

A-10. Message Terminator. The two left-most positions of rear-panel switch S1 permit a choice of message terminators, as shown in Table A-2.

TABLE A-2. MESSAGE-TERMINATOR SELECTION

SWITCH		MESSAGE TERMINATOR
7	6	
Off	Off	EOI
Off	On	CR*
On	Off	LF*
On	On	CR LF*

* With or without EOI

A-11. Command Response. In addition to Talk and Listen Address commands, the instrument responds to the following:

a. Address Commands (Response if Listen Addressed).

Mnemonic	Name	Function
GTL	Go To Local	Enables panel control
GET	Group Execute Trigger	Trigger a measurement

b. Listen Address Group.

Mnemonic	Name	Function
UNL	Unlisten	De-address as listener

c. Talk Address Group.

Mnemonic	Name	Function
UNT	Untalk	De-address as talker

d. Unencoded Commands.

Mnemonic	Name	Function
IFC	Interface Clear	Initialize interface
REN	Remote Enable	Permits remote operation

A-12. Operating States. The instrument operates in two separate states, whether in local or remote control. One state is the measurement state, during which the instrument performs and displays measurements; the other state is the data entry/recall state, which is operative during number entry or after recall of stored information. When operating on the bus, it is important to remember that the instrument can send only that information which appears on the front panel display.

a. **Measurement Mode Functions.** The following functions change the measurement mode of the instrument:

Keyname	GPIB	Function
MODE mV	P	Display measured voltage
MODE dBmV	B	Display measured dBmV
MODE dBV	V	Display measured dBV
MODE dB	D	Display measured dB
RANGE AUTO	A	Set autorange mode
RANGE HOLD	O	Set range hold mode

b. **Data Entry/Recall Functions.** These functions enable entry or retrieval of numeric constants used by the instrument. Operation reverts to the measuring state after data storage.

Keyname	GPIB	Function
LIMITS dB LO	L	Low limit value in dB
LIMITS dB HI	H	High limit value in dB
SELECT CHNL	N	Select channel number
dB REF LEVEL dB	R	dB reference level for dB modes
SELECT Z ₀	I	Impedance reference for 1 mW

c. **Special Functions.** Special functions include the automatic zeroing and clear functions.

Keyname	GPIB	Function
ZERO	Z	Initiate an automatic zeroing cycle
CLR	C	Clear numeric entry to zero

d. **IEEE-488 Bus Command Extensions.** The following functions are added to bus operation:

Name	GPIB	Function
ADR. ZERO	Y	Zero selected ranges (0-7)
SET RANGE	G	Set to selected range (0-7)

These commands must be preceded by an appropriate argument. The argument for Y is the span of ranges to be zeroed; for example: 26Y specifies zeroing of ranges 2 through 6. If only one range is to be zeroed, the argument must begin and end with the same code (e.g., 11Y to zero only range 1). The argument for G is the range number (0 = 1 mV to 7 = 3000 mV for 9200A probes) to be set.

Name	GPIB	Function
Trigger	T	Used with controllers that do not have Group Execute Trigger capability.
Hold Measurement	IQ	Measures on trigger and holds until it receives another trigger or 0Q. (See NOTE.)
Unhold Measurement	0Q	Negates Hold Measurement if previously invoked.
Service Request	IS	Requests service upon completion of a measurement.
No Service Request	0S	Negates Service Request if previously invoked.

NOTE

When the instrument is in the Hold-Measurement mode, and is holding a measurement, data entries will be accepted but the instrument will not return to the Measurement mode until it receives a trigger.

e. **Bus Availability.** When the Model 9200A is sent a string, it does not normally tie up the bus while responding to the string; other bus communications are possible during the interval. The 9200A can inform the controller when it is finished by use of the Service Request (see A-12d, above), if this is desired.

The Model 9200A can, however, be made to lock up the bus while it is responding to a string—if such action is desired—by sending it two strings in succession (even if the second string is only a Null command).

Example: A “zero” command: WRT 716,“Z”
Followed by a “talk” command: RED 716,A,B,C

A-13. REMOTE PROGRAMMING.

NOTE

It is assumed that the user is acquainted with GPIB principles and terminology. Refer to the controller instruction manual for the syntax needed to create specific bus commands and addressing sequences. All examples given apply to the HP 9825 calculator.

A-14. Bus Programming Syntax. The bus programming syntax mirrors the front-panel keystroke sequence closely. Each key has been assigned an alphanumeric character, and sending that character is equivalent to pressing that front-panel key. The resulting operation is indistinguishable from local control. Numerical values are translated by

Appendix A
IEEE-488 Bus Interface
Option 9200A-01A

the GPIB interface so that commonly observed formats may be used. Fixed formats and floating-point formats may both be used. These representations are converted to their equivalent fixed-point values, and the sign information is post-fixed automatically, thereby ensuring that natural notations for numbers will be accepted by the instrument.

A-15. Suppose that it is desired to set the instrument to the mV mode. The HP 9825 calculator could be programmed:

```
wrt 716, "P"
```

The "wrt" instructs the calculator to send data on the bus to one or more listeners. The number following is the address information; 7 is the calculator address, and 16 is the instrument address. (All examples in this appendix will use 16 as the instrument address, although any valid address can be assigned to the instrument.) When the calculator interprets the first part of the line, it will assert the ATN line to signify that commands or addresses will be sent on the bus. Following that, it will send three bytes or characters: Unlisten, the calculator Talk Address, and the instrument Listen Address. This information will configure both the calculator and the instrument for the data transfer. After the last command byte has been accepted, ATN will be released to the false state by the calculator. All information on the bus is interpreted as data in this mode. While in the data mode, the calculator will send the character "P" to the instrument. At this instrument, this will be interpreted as equivalent to pressing the MODE mV key, and that function will be executed. Because there is no more data to be sent, the calculator will send a delimiter (the preselected message terminator, see Table A-2). The instrument recognizes the message terminator as an end-of-message signal, and returns to the bus idle condition.

A-16. The preceding discussion of the sending of a single programming byte serves to illustrate two important points: every data transfer is preceded by a command/address preamble, and each transfer is terminated by a message terminator (see Table A-2). In the preceding example, six characters were sent on the bus; only one was a programming byte.

A-17. The measurement mode functions (P, B, A, O, V, D) and the special functions (Z, C) do not expect any numeric value. These functions all are executed as received. For example: the following will program dBmV and autorange mode:

```
wrt 716, "BA"  
or  
wrt 716, "AB"
```

Note that the sequence is unimportant, except that each function is executed in the order it is received on the bus.

A-18. Suppose that the instrument is to be zeroed automatically, and then asked to send the reading in the mV and RANGE AUTO modes. The HP 9825 calculator could be instructed as follows:

```
wrt 716, "APZ"  
red 716, V, S, Y
```

The automatic zeroing cycle time is approximately 7 seconds. Until zeroing is completed, the instrument is unable to respond with new data. The first line of the preceding instructions sets the operating mode and initiates the zeroing cycle. The last line reads the response from the instrument. The instrument response consists of three numeric values: the first value is the front panel reading, the second is a status value (normally zero), and the third is the range. These three numbers will be stored in the calculator variable (storage locations) V, S, and Y. Note that each data transmission from the instrument consists of three values. When the status value is non-zero, indicating an error condition, the data value will be set to zero. The program will normally test the status value to assure valid operating conditions.

A-19. Store/Recall Functions Syntax. The generator syntax for store/recall functions is the same as the front panel sequence; if a numeric value immediately precedes the function, that value will be stored; otherwise, the existing stored value will be recalled to the front panel. These functions (L, H, N, R, I) thus operate in a dual mode.

A-20. Suppose that it is desired to store the current voltage level in dB into the dB reference so that all future readings will be referred to the current value. Allowance must be made for the possibility that the current value is a dB relative value. To do this, the current dB value must be read, the existing dB reference must be recalled, the true dB value must be computed, and this value must be stored into dB reference. The calculator could be instructed as follows:

```
red 716, V, S, A  
wrt 716, "R"  
red 716, X, S, A  
V+X→Y  
wrt 716, Y, "R"
```

Note that R is used twice in the program, the first time to obtain the existing value for the dB reference, and the second time to store the computed value. Also, note that the two read statements (red) each fetch a different value; the first value is the voltage value in dB, and the second is the dB reference.

A-21. Output Data Format. The data output of the instrument consists of a string containing voltage meas-

urement mode, channel in use, front panel display, status of measurement, and the range code. The following format is used:

abcsdddEsd, S, R, (cr) (lf)

Where:

ab = mode (MV = voltage in mV; DM = dBmV mode; DR = dB reference mode; DV = dBV mode; DB = dB mode)

c = channel (A = 1; B = 2; C = 3)

s = sign (+ or -)

ddd = data (four digits, each digit 0 through 9)

Esd = exponent, sign, digit

, = data delimiter

S = status digit:

0 = no error

1 = entry too small

2 = entry too large

3 = measurement underrange

4 = measurement overrange

5 = zero acquisition out of range - excessive negative offset (hardware malfunction, e.g., input connector polarity reversed; negative chopper offset)

6 = zero acquisition out of range - excessive positive offset (input too large)

7 = channel 3 over/under range

R = range digit

0 = 1 mV

1 = 3 mV

2 = 10 mV

3 = 30 mV

4 = 100 mV

5 = 300 mV

6 = 1000 mV

7 = 3000 mV

cr = carriage return

lf = line feed

A-22. Hold Measurement Function Syntax. The hold measurement function will hold the current instrument measurement and prevent another measurement until otherwise commanded. The syntax for hold is IQ and for unhold (return to normal measuring) is 0Q.

NOTE

If a command is sent during the hold measurement mode, the instrument display will not return to the previous measurement displayed.

A-23. SRQ Function Syntax. The controller can command the instrument to pull the SRQ line true after each measurement. The syntax for this command is IS; to command the instrument not to pull the SRQ line true after each measurement, the syntax is 0S.

A-24. Measurement Trigger Syntax. A T command on the interface bus will force an instrument measurement. This command is identical to the IEEE-488 bus Group Execute Trigger command.

A-25. Typical Application. Suppose that it is desired to measure insertion loss or gain with an instrument equipped with option 9200A-03, where channel 2 measures input voltage and channel 1 measures output voltage. The program shown below will request reference conditions and wait for the user to set them up. Following establishment of the reference, the program will loop on insertion loss/gain measurements. Each measurement is triggered by the user. Zeroing is prompted in the local mode at the beginning of the program. Reading errors, should they occur, will be signalled by a double beep from the calculator; normal measurements will give a single beep. There will be one print line per measurement. The reference value is not printed in this example.

Program Variable Usage:

P: = voltage measurement value

S: = status value

Z: = dummy input for prompts

R: = range value

Program Statements	Comments
0: cli 7	Clear interface
1: ent "zero chl,2",Z	Prompt for zeroing
2: rem 7	Enable remote
3: wrt 716, "1NA0R2NA0R3N"	0 dB ref, auto - set ch 3
4: ent "ref measure", Z	Prompt to set up ref
5: red 716, P, S, R	Read ref value, status
6: if S>0; dsp "error", S; beep, gto4	Test status
7: wrt 716,"1N", P, "R3N"	Set ch 1 dB ref = P
8: beep; ent "measure", Z	Prompt for measurement
9: red 716, P, S, R	Read measurement, status
10: if S>0; dsp "error", S; beep; wait 100; gto8	Test status
11: prt P, "dB"; gto8	Print measurement
12: end	

Appendix A
IEEE-488 Bus Interface
Option 9200A-01A

A-26. The program in the preceding paragraph also measures reflection coefficient if channel 1 measures reflected voltage and channel 2 measures incident voltage. The reference conditions are established with a short at the test port of the directional coupler.

A-27. Use of Hold Measurement Command (Q), Trigger Command (T) and Measurement-Complete-SRQ Commands (V). An example of the use of these commands using an HP Model 85 controller, BEC Model 1020 generator and the BEC Model 9200A RF Voltmeter follows:

Statement	Comment
10 ! TQSCHK	Program name
20 REMOTE 7 @ CLEAR	Enable remote; clear display
30 OUTPUT 703 ;"IN5010RQOSAD"	Set model 9200A; ch 1 sensor 1, $Z_0 = 50 \Omega$ s, 0 reference dB, no hold indication, no measurement-complete-SRQ, auto range mode, dB display mode
40 OUTPUT 702 ;"1MHLOON"	Set model 1020; 1 MHz, output level of 0 dBm, output on
50 OUTPUT 703;"1Q"	Set model 9200A to hold-indication mode
60 OUTPUT 702 ;"OL-10"	Set model 1020 to -10 dBm level
70 ENTER 703; A	Read model 9200A; store in A
80 PRINT A	Print model 9200A indications (A)
90 DISP"PRESS CONTINUE FOR T C COMMAND"	Display prompt on model 85
100 PAUSE @ BEEP	Stop program; issue beep (press continue)
110 OUTPUT 703; "T"	Send T (trigger command to model 9200A
120 ENTER 703; A	Read model 9200A indication; store in A
130 PRINT A	Print model 9200A indication
140 OUTPUT 703;"0Q"	Set model 9200A for no hold-indication auto range mode, dB mode
150 DISP"PRESS CONTINUE FOR 1S COMMAND"	Display prompt on model 85
200 PAUSE @ BEEP	Stop program; issue beep

210 OUTPUT 702;"0L0"	Set model 1020 to dBm output
220 WAIT 1000	Wait 1 second for settled indication on 9200A
230 ON INTR 7 GOTO 290	If interrupt occurs, branch to 290
240 OUTPUT 703;"1S"	Set model 9200A to issue an SRQ at completion of measurement
250 WAIT 200	Wait 0.2 seconds
260 ENABLE INTR 7;8	Enable SRQ interrupt in model 85
270 ON TIMER# 1,5000 GOTO 370	If no interrupt is received in 5 seconds, branch to 370
280 GOTO 280	Wait for interrupt (or escape after 5 seconds - step 270)
290 OUTPUT 703;"0S"	At interrupt, set model 9200A to no-measurement-complete SRQ
295 WAIT 200	Wait 0.2 seconds
300 S=SPOLL(703)	Store result of serial poll of model 9200B in S
310 IF BIT(S,6)<>1 THEN GOTO 370	If bit 6 (SRQ bit) of model 9200A service request byte does not =1, go to 370
320 PRINT "MEAS-COMP-SRQ"	If bit 6 does =1 (SRQ bit) print "MEAS-COMP-SRQ"
340 DISP"PRESS CONTINUE FOR OS COMMAND"	Display prompt on model 85
350 PAUSE @ BEEP	Stop program; issue beep
360 GOTO 260	Go to 260
370 PRINT"NO MEAS-COMP-SRQ"	There has been no service request
380 PRINT "DONE"	Check is complete; print "DONE"
390 END	

In the above example, the addresses of the devices are:

Device	Address
HP Model 85B	7
BEC Model 1020	7
BEC Model 9200A	2

Appendix A
IEEE-488 Bus Interface
Option 9200A-01A

The sequence of events in the example program are as follows:

HP Model 85 Controller	Comments
RUN	The model 9200A will read the signal generator level of approximately 0 dBm and this will be printed by the model 85B; the model 1020 will change its level to -10 dBm, but the model 9200A will not change its indication since it is in the hold-indication mode; program stops at pause and waits for continue on model 85.
CONTINUE	This issues a T (trigger) command to the model 9200A, which now changes to approximately -10 dBm; this is printed by the model 85. The program stops and waits for continue.
CONTINUE	This initiates a sequence in which the measurement-complete-SRQ is enabled.
CONTINUE	This initiates a sequence in which the measurement-complete-SRQ has been disabled.

A-XX. Sealed System Operation. When in sealed system operation (selected by the control board bit switch) the instrument will power up in the operate mode but, by the use of the proper GPIB commands this instrument can be placed in the DC or AC modes to allow calibration of the instrument over the bus without removal from the system rack. The GPIB commands are:

Operate Mode	"80m"
Calibrate Mode 1 (DC Cal)	"81m"
Calibrate Mode 2 (AC Cal)	"82m"

A-28. THEORY OF OPERATION.

A-29. General. Interface board A23 is a microprocessor-driven data interface which converts IEEE 488 bus compatible signals into control codes that operate the internal control bus of the instrument. It also converts instrument data into IEEE 488 compatible signals for use on the bus. All data transfers are handled by source and acceptor handshake protocols as defined by IEEE-488-1978.

A-30. Detailed Description. Refer to Figure A-1. All data manipulation and IEEE 488 bus management are controlled by CPU A51C3 on the instrument control board in conjunction with a micro-program stored in PROM A23U1 on the interface board. All data transfer is handled in parallel-to-parallel mode by adapter A23U4. Latch A23U5 handles transfer of bit switch data that defines the instrument address and message termination characters to the instrument data bus. Bi-directional buffers A23U6 and A23U7 handle data and control signal transfers, respectively, between adapter A23U4 and the interface buses.

A-31. When the instrument is turned on, the RESET line to adapter A23U4 is set low while capacitor A23C1 charges through pull-up network A23U1, thereby clearing the adapter. To initiate an interface transaction, signal ROM-IF is set low by CPU A51C3, thereby enabling the output of PROM A23U1. Interface micro-program instructions from the PROM memory location specified by the address bits from the CPU are written onto the instrument data bus. The CPU executes these instructions and activates the control signals required to perform the commanded interface transaction.

A-32. Instrument address and message termination character data manually preset into bit switch A23S1 is supplied to latch A23U5. To read the switch data, control signals RD and CSTF and address bit A6 are activated, thereby enabling the latch output through gates A23U2c and A23U2b and inverter A23U3c. The switch data is then transferred through the latch to the instrument data bus.

A-33. To read incoming interface control signals, the CPU activates signals RD and CSTF and sets address bit A6 low. The interface control signal port of adapter A23U4 is selected through address bits A0, A1 and A5. Adapter A23U4 is enabled through gate A23U2a. Because signal RD is active, signal TE supplied by the adapter to buffer A23U7 is inactive, and this buffer is set up for data transfer from the interface control signal bus to the control signal port of adapter A23U4. Incoming interface control signals are transferred through buffer A23U7 and adapter A23U4 to the instrument data bus. Clocking of adapter operations is controlled by the clock signal from the instrument control board. Interface control signal transfer in the opposite direction is achieved by reversing the states of signals RD and WR. An active WR causes signal TE to buffer A23U7 to become active, thereby reversing the direction of data flow through the buffer. Interface control signals from the instrument data bus are then written onto the interface control bus through adapter A23U4 and buffer A23U7. Interface control signals are defined as follows:

DAV	DATA VALID
NRF	NOT READY FOR DATA
NDAC	NOT DATA ACCEPTED
ATN	ATTENTION
IFC	INTERFACE CLEAR
REN	REMOTE ENABLE
SRQ	SERVICE REQUEST
EOI	END OR IDENTIFY

A-34. To handle data transfers between the instrument data bus and the interface data bus, adapter A23U4 is similarly enabled through gate A23U2a by control signal CSTF and a low address bit A6. Address bits A0, A1 and A5 are set to select the data port of adapter A23U4 and

D831237A

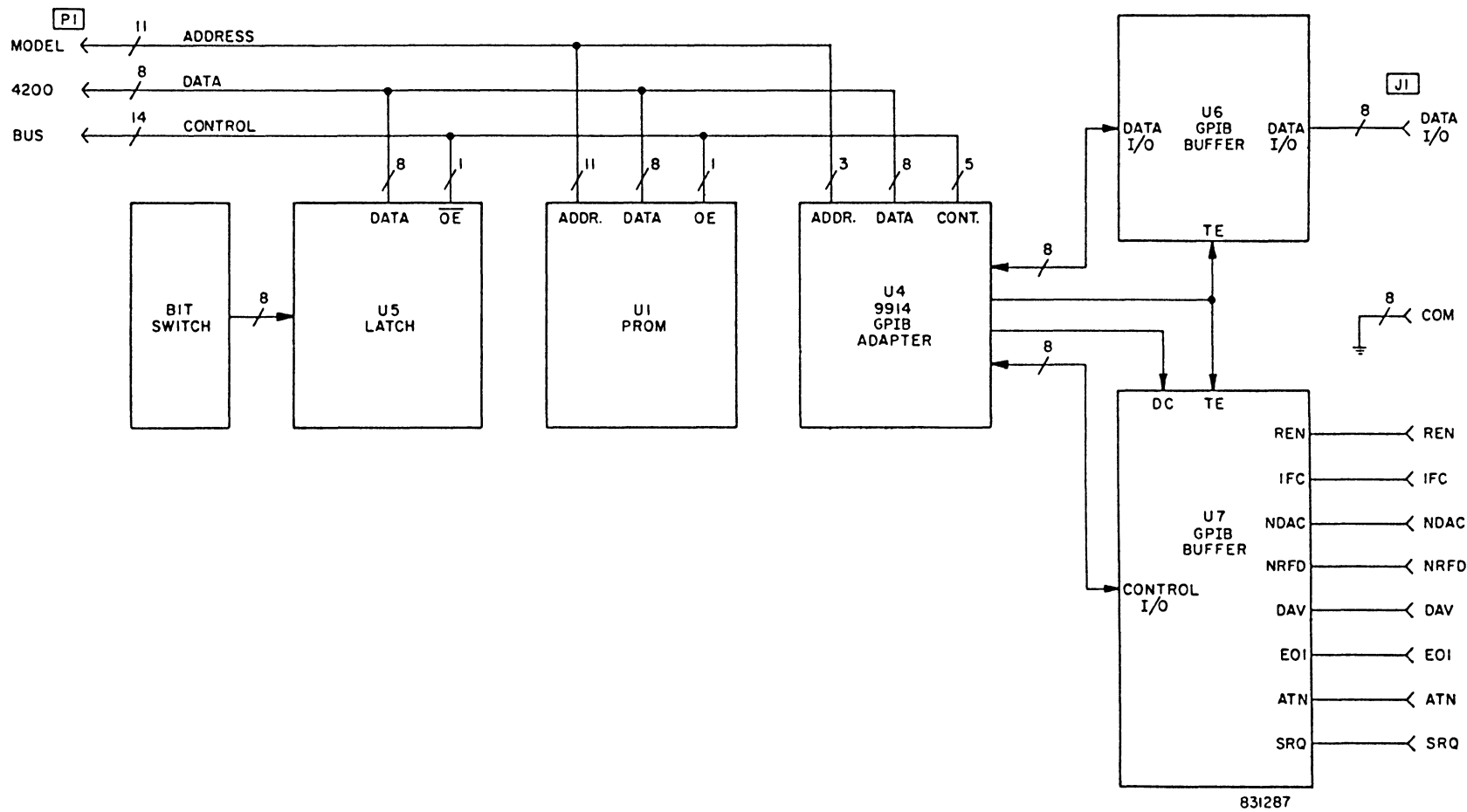

Figure A-1. IEEE-488 Bus Interface Option 9200A-01A, Block Diagram

Appendix A
IEEE-488 Bus Interface
Option 9200A-01A

signals \overline{WR} and \overline{RD} specify the write and read functions. If data is to be written onto the interface data bus, signal \overline{WR} is activated, thereby activating signal TE to buffer A23U6. Data on the instrument data bus is then transferred through adapter A23U4 and buffer A23U6 to the interface data bus. For data transfers from the interface data bus to the instrument data bus, signal \overline{WR} is inactive and signal \overline{RD} is active. Signal TE to buffer A23U6 is deactivated by adapter A23U4 to reverse the direction of data transfer through the buffer.

A-35. MAINTENANCE.

A-36. General. The interface board does not operate alone, but rather in conjunction with the Model 9200A. If interface operation becomes abnormal it should first be determined if the 9200A operates normally *without* the interface. If it does, proceed according to the following paragraphs.

A-37. Physical Inspection. Check the interface board visually for loose or broken connectors, unseated IC's, foreign

material, etc.

A-38. Voltage Checks. With the board installed in the 9200A, and all connectors in place, check the supply- and IC-voltages according to the values shown on the schematic diagram, Figure A-2.

A-39. Active-Device Substitution. All the active devices are socketed, making replacement simple. Replace each device, one at a time, and check for restoration of proper performance by the instrument.

A-40. Signature Analysis. Included in Section IV of the 9200A's instruction manual is a discussion of signature analysis, together with a table of correct signatures for PROM U1.

A-41. Other Analyses. An oscilloscope, while not the most useful tool for troubleshooting bus-oriented microprocessor systems, still may be used to determine activity or lack of activity on the address, data, and control lines.

Replaceable Parts List for Interface PC BD Assy

PL 042317-01

Item	Description	Mfr.	Mfr's Part No.	BEC Part No.
C1	Cap Tant 1 μ F 10% 35V (only)	01247	196D105X9035HA1 (only)	283216
C2	Cap EL 10 μ F 20% 25V	54217	SM-25-VB-10-M	283336
C3	Cap EL 10 μ F 20% 25V	54217	SM-25-VB-10-M	283336
CR1	Diode Sig 1N914	01295	1N914	530058
GND	Terminal Pin	98291	229-1071-47	510041
J1	Connector 24 Pin	27264	1-332070-7	479350
P2	Connector Modified M/F 477329	04901	BEC	477333
R1	Res Network 4.7k ohm 2%	01121	3168472	345020
S1	Dip Switch	71450	206-7	465215
TP5	Terminal Pin	98291	229-1071-47	510041
TP18	Terminal Pin	98291	229-1071-47	510041
U1	IC EPROM M/F534181 PED	04901	BEC	534289
U2	IC SN74LS32N	01295	SN74LS32N	534168
U3	IC SN74LS04N	01295	SN74LS04N	534155
U4	Mos Micro Processor	01295	TMS9914ANL	534288
U5	IC SN74LS373N	01295	IC SN74LS373N	534237
U6	IEEE-488 GPIB Bus Transceiver	01295	SN75160AN	534286
U7	IEE-488 GPIB Bus Transceiver	01295	SN75161AN	534287
XS1a	Socket IC 8 Pin Right Angle	91506	508-AG7D	473053
XS1b	Socket IC 8 Pin Right Angle	91506	508-AG7D	473053
XU1	Socket IC 24 Pin	06776	ICN-246-S4-G	473043
XU2	Socket IC 14 Pin	06776	ICN-143-S3-G	473019
XU3	Socket IC 14 Pin	06776	ICN-143-S3-G	473019
XU4	Socket IC 40 Pin	06776	ICN-406-S4-G	473052
XU5	Socket IC 20 Pin	06776	ICN203-S3-G	473065
XU6	Socket IC 20 Pin	06776	ICN203-S3-G	473065
XU7	Socket IC 20 Pin	06776	ICN203-S3-G	473065

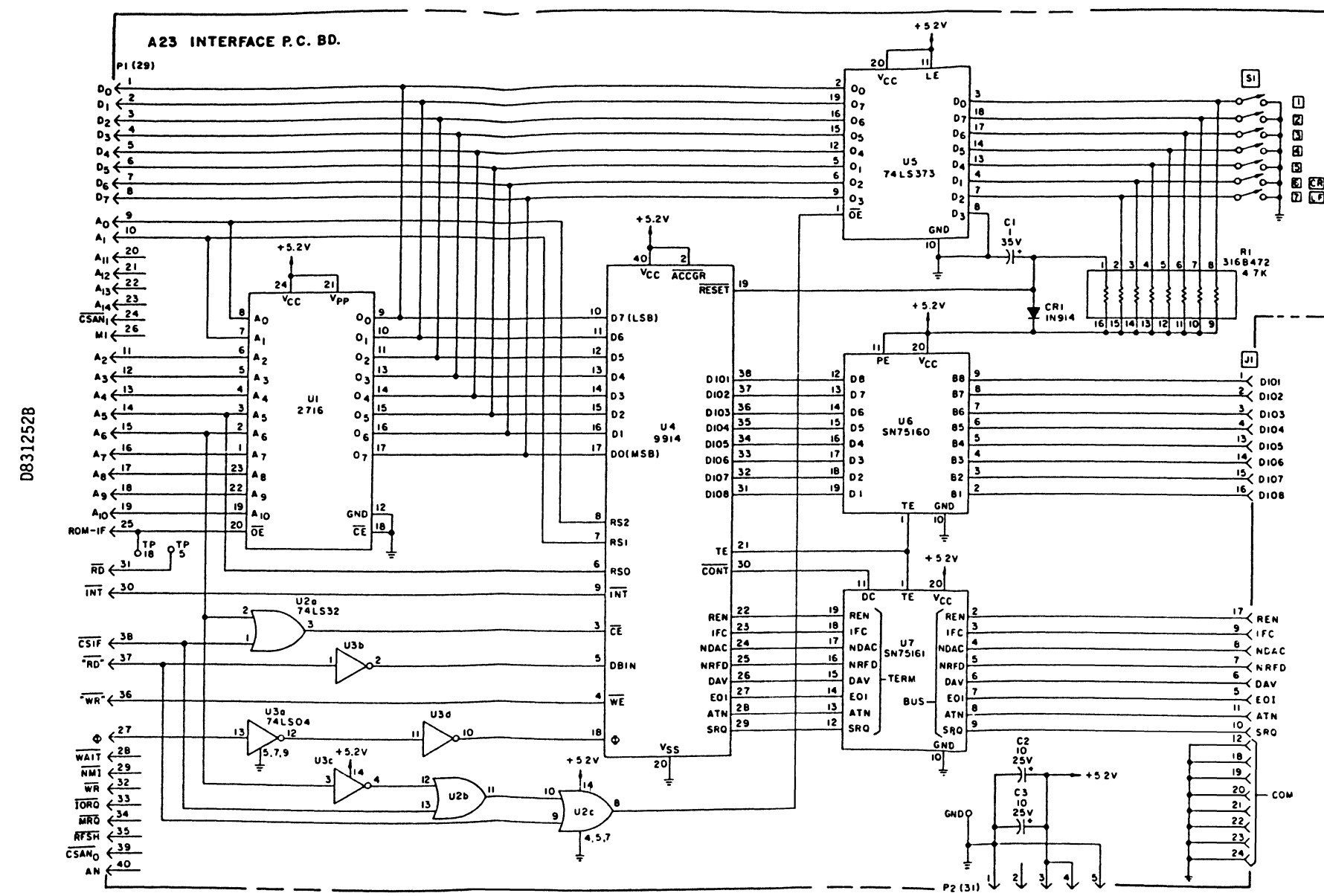
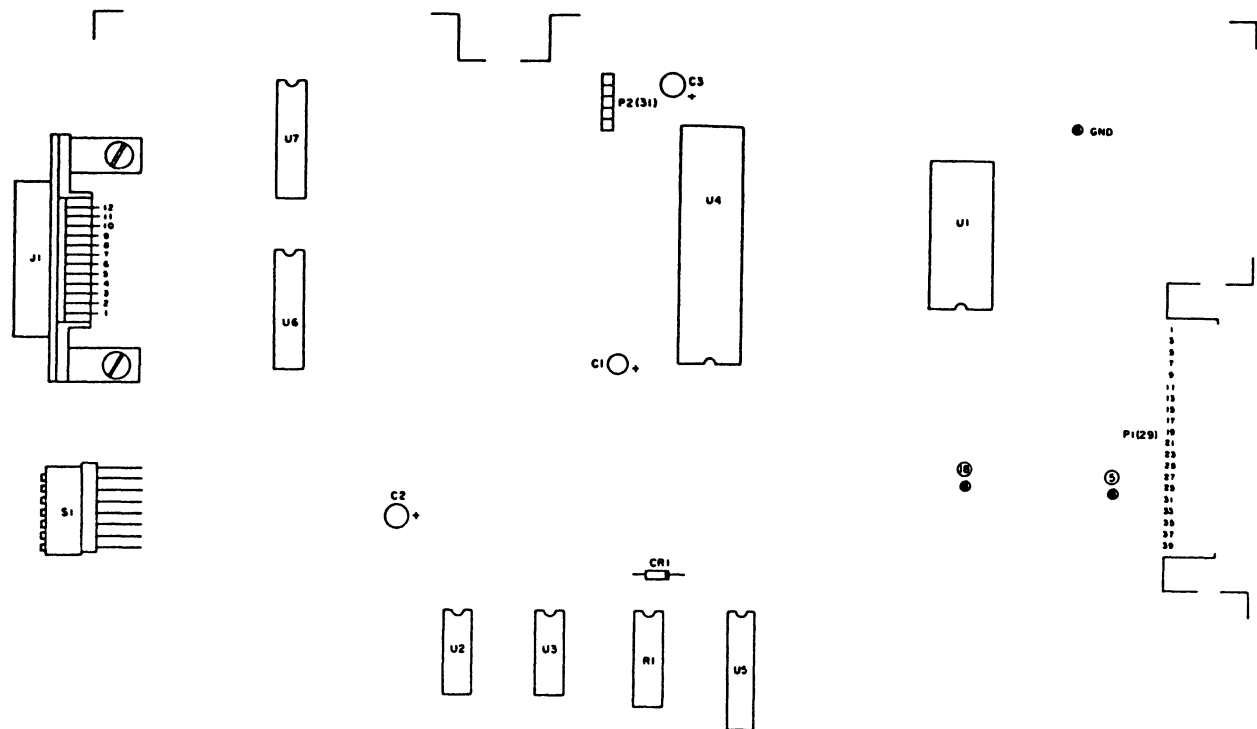

- NOTES
1. CAPACITANCE VALUES IN μ F UNLESS OTHERWISE SPECIFIED.
 2. EXTERNAL MARKINGS.
 3. LAST NUMBERS USED:
 4. TEST POINT.

P1(29)
 CONNECTS TO
 420W20J28(29)
 ON OPTION MAIN
 FRAME SCHEMATIC
 831099

P2(31)
 CONNECTS TO
 A1W21 J31(31)
 ON MAIN SCHEMATIC
 831271, SHT 1 OF 7

Figure A-2 Interface Board A23, Schematic Diagram

APPENDIX B

INPUT CHANNEL 2

OPTION 9200A-03

B-1. DESCRIPTION.

B-2. Option 9200A-03 provides an additional measurement channel (channel 2) that is identical to channel 1 except for mounting and input connector location. The input channel 2 connector for this channel is mounted on the rear panel of the instrument. With this option installed, measurements may be made on each channel individually, or both channels can be monitored automatically and their difference in dB displayed. This option consists of a second input module, complete with chopper, that connects to the 40-line bus and has its own power connector. Connections are shown in Figure 6-7.

B-3. INSTALLATION AND REMOVAL.

B-4. To install and remove the input channel 2 option, proceed as follows:

a. Turn the instrument bottom up. Remove the screw that secures the bottom cover, and slide the bottom cover back and off.

b. Remove the four black flat-head screws on each side that secure the side covers.

c. Using the two screws supplied with the option, install the rear input connector at the left side of the rear panel.

d. Dress the cable from the rear input connector down the left side frame of the instrument (as viewed from the bottom of the instrument) and across the front sub-panel. The cable will run below the module being installed.

e. Secure the cable grounding lug under the uppermost, rightmost binder-head screw (6-32) in the front sub-panel.

f. Install the channel 2 input module and secure it to the side frames of the instrument with the four screws supplied with the option.

g. Remove the four corner screws that secure the channel 2 input module cover, and remove the cover.

h. Plug the channel 2 chopper into the channel 2 input module, seating the chopper firmly.

i. Depending on the options specified at the time of

instrument purchase, the front 40-pin ribbon cable connector for the channel 2 input module may already be installed in the instrument; if it is, connect it to the front edge connector of the channel 2 input module. If the cable is not already installed, remove the present connector assembly and install the new assembly supplied with the input channel 2 option. Connector spacing on the ribbon cable is such that it can be installed only in the correct way. If no interface module (option 9200A-01A) is installed in the instrument, there will be an unused connector in the upper section of the instrument. Make sure that all connectors that are used are fully engaged with their respective modules.

j. Connect the power cable supplied to the power supply (position 8) with the black lead on the right side (as viewed from the bottom of the instrument) and to the input module (rear) with the black lead on the right.

NOTE

Avoid reversal of the two ends of this cable; there is lead transposition.

k. Install the channel 2 input module cover that was removed in step g.

l. Install the side covers and the bottom cover removed in steps a and b.

m. To remove the channel 2 input module, reverse the above procedure.

B-5. OPERATION.

B-6. When option 9200A-03 is installed, each of the two input channels may be operated independently with its own probe. Probe data and measurement parameters stored in the instrument non-volatile memory for each of the two input channels are selected automatically when the associated channel is selected.

B-7. Channel 1 and channel 2 operating procedures are basically the same as those described in Section II of this manual. A channel 3 mode of operation may also be selected. In the channel 3 mode, the input levels to channels 1 and 2 are both monitored, and the difference between the two inputs, in dB referred to channel 2, is shown on the instrument display. The following parameters selected for

Appendix B
Input Channel 2
Option 9200A-03

channels 1 and 2 prior to selection of the channel 3 mode remain operative for channel 3 mode operation:

- a. Autoranging or range hold (for each channel)
- b. Limits (for each channel)
- c. dB reference levels (for each channel)
- d. Zeroing

B-8. When channel 3 mode has been selected, the following keys are inactive:

- a. ZERO
- b. MODE mV
- c. MODE dB (instrument is automatically in this mode)
- d. dB LIMITS LO and dB LIMITS HI
- e. dB REF LEVEL dB

The recorder output in channel 3 mode is a function of channel 1 dB only.

B-9. MAINTENANCE

B-10. The procedures used to isolate malfunctions to the channel 2 input module are similar to those described for the channel 1 input module in Section IV of this manual. (Refer to paragraph 4-17b.) Signature analysis techniques are used to isolate defective parts on the channel 2 input module. For convenience, the signature analysis information for the channel 2 input module is included in Section IV. (Refer to Tables 4-20, 4-21, 4-22 and 4-23.)

APPENDIX C

REAR INPUT

OPTION 9200A-04

C-1. DESCRIPTION.

C-2. Rear input option 9200A-04 provides a second probe connector on the rear panel of the instrument for those applications where such a connection may be more convenient than the front-panel connection. The second probe connector is connected in parallel with the front-panel SENSOR connector. (See Figure 6-7.)

C-3. OPERATION.

C-4. To operate an instrument equipped with the 9200A-04

option, connect the probe to either the front-panel or rear-panel connector, as desired, and affix the shield supplied with the option to the unused connector. Then, proceed with operation as described in Section II.

NOTE

Do not attempt to use both input connectors at the same time; use only one, and make sure that the shield is affixed to the other.