

Specifications Guide

Agilent Technologies

ESA-E Series Spectrum Analyzers

This manual provides documentation for the following instruments:

Agilent Technologies

E4401B (9 kHz – 1.5 GHz)

E4402B (9 kHz – 3.0 GHz)

E4404B (9 kHz – 6.7 GHz)

E4405B (9 kHz – 13.2 GHz)

E4407B (9 kHz – 26.5 GHz)



Agilent Technologies

Manufacturing Part Number: E4401-90242

Printed in USA

March 2001

Supersedes: E4401-90225

© Copyright 2000, 2001 Agilent Technologies

COPYRIGHT AND DISCLAIMER NOTICE

Copyright – Agilent Technologies, Inc. Reproduced with the permission of Agilent Technologies Inc. Agilent Technologies, Inc. makes no warranty of any kind with regard to this material including, but not limited to, the implied warranties of merchantability and fitness for a particular purpose. Agilent Technologies, Inc. is not liable for errors contained herein or for incidental or consequential damages in connection with the furnishing, performance, or use of this material or data.

The information contained in this document is subject to change without notice.

Agilent Technologies makes no warranty of any kind with regard to this material, including but not limited to, the implied warranties of merchantability and fitness for a particular purpose. Agilent Technologies shall not be liable for errors contained herein or for incidental or consequential damages in connection with the furnishing, performance, or use of this material.

The following safety symbols are used throughout this manual. Familiarize yourself with the symbols and their meaning before operating this instrument.

WARNING

***Warning* denotes a hazard. It calls attention to a procedure which, if not correctly performed or adhered to, could result in injury or loss of life. Do not proceed beyond a warning note until the indicated conditions are fully understood and met.**

WARNING

This is a Safety Class 1 Product (provided with a protective earthing ground incorporated in the power cord). The mains plug shall only be inserted in a socket outlet provided with a protected earth contact. Any interruption of the protective conductor inside or outside of the product is likely to make the product dangerous. Intentional interruption is prohibited.

WARNING

If this product is not used as specified, the protection provided by the equipment could be impaired. This product must be used in a normal condition (in which all means for protection are intact) only.

CAUTION

Caution denotes a hazard. It calls attention to a procedure that, if not correctly performed or adhered to, could result in damage to or destruction of the instrument. Do not proceed beyond a caution sign until the indicated conditions are fully understood and met.

CAUTION

Always use the three-prong ac power cord supplied with this product. Failure to ensure adequate earth grounding by not using this cord may cause product damage.

CAUTION

This instrument has autoranging line voltage input, be sure the supply voltage is within the specified range.

Warranty

This Agilent Technologies instrument product is warranted against defects in material and workmanship for a period of one year from date of shipment. During the warranty period, Agilent Technologies Company will, at its option, either repair or replace products which prove to be defective.

For warranty service or repair, this product must be returned to a service facility designated by Agilent Technologies. Buyer shall prepay shipping charges to Agilent Technologies and Agilent Technologies shall pay shipping charges to return the product to Buyer. However, Buyer shall pay all shipping charges, duties, and taxes for products returned to Agilent Technologies from another country.

Agilent Technologies warrants that its software and firmware designated by Agilent Technologies for use with an instrument will execute its programming instructions when properly installed on that instrument. Agilent Technologies does not warrant that the operation of the instrument, or software, or firmware will be uninterrupted or error-free.

LIMITATION OF WARRANTY

The foregoing warranty shall not apply to defects resulting from improper or inadequate maintenance by Buyer, Buyer-supplied software or interfacing, unauthorized modification or misuse, operation outside of the environmental specifications for the product, or improper site preparation or maintenance.

NO OTHER WARRANTY IS EXPRESSED OR IMPLIED. AGILENT TECHNOLOGIES SPECIFICALLY DISCLAIMS THE IMPLIED WARRANTIES OF MERCHANTABILITY AND FITNESS FOR A PARTICULAR PURPOSE.

EXCLUSIVE REMEDIES

THE REMEDIES PROVIDED HEREIN ARE BUYER'S SOLE AND EXCLUSIVE REMEDIES. AGILENT TECHNOLOGIES SHALL NOT BE LIABLE FOR ANY DIRECT, INDIRECT, SPECIAL, INCIDENTAL, OR CONSEQUENTIAL DAMAGES, WHETHER BASED ON CONTRACT, TORT, OR ANY OTHER LEGAL THEORY.

Where to Find the Latest Information

Documentation is updated periodically. For the latest information about Agilent Spectrum Analyzers, including firmware upgrades and application information, please visit the following Internet URL: <http://www.agilent.com/go/esa>.

Contents

1. Agilent E4401B Specifications and Characteristics

| | |
|---|----|
| About This Chapter | 2 |
| Frequency | 4 |
| Amplitude | 10 |
| Options | 22 |
| Time Gated Spectrum Analysis (Option 1D6) | 22 |
| Tracking Generator (Option 1DN or 1DQ) | 23 |
| FM Demodulation (Option BAA) | 27 |
| TV Trigger and Picture On Screen (Option B7B) | 28 |
| General | 29 |
| Inputs and Outputs | 34 |
| Internal | 34 |
| Front Panel | 34 |
| Rear Panel | 35 |
| Regulatory Information | 40 |
| Declaration of Conformity | 41 |

2. Agilent E4402B Specifications and Characteristics

| | |
|---|-----|
| About This Chapter | 44 |
| Frequency | 46 |
| Amplitude | 53 |
| Options | 65 |
| Time Gated Spectrum Analysis (Option 1D6) | 65 |
| Tracking Generator (Option 1DN) | 66 |
| Bluetooth™ FM Demodulation (Option 106) | 70 |
| Bluetooth Measurements Personality (Option 228) | 71 |
| FM Demodulation (Option BAA) | 74 |
| TV Trigger and Picture On Screen (Option B7B) | 75 |
| cdmaOne Measurement Personality (Option BAC) | 76 |
| GSM Measurement Personality (Option BAH) | 85 |
| General | 92 |
| Inputs and Outputs | 97 |
| Front Panel | 97 |
| Rear Panel | 98 |
| Regulatory Information | 104 |
| Declaration of Conformity | 105 |

Contents

3. Agilent E4404B Specifications and Characteristics

| | |
|---|-----|
| About This Chapter | 108 |
| Frequency | 110 |
| Amplitude | 117 |
| Options | 129 |
| Time Gated Spectrum Analysis (Option 1D6) | 129 |
| Tracking Generator (Option 1DN) | 130 |
| Bluetooth FM Demodulation (Option 106) | 134 |
| Bluetooth Measurements Personality (Option 228) | 135 |
| FM Demodulation (Option BAA) | 138 |
| TV Trigger and Picture On Screen (Option B7B) | 139 |
| cdmaOne Measurement Personality (Option BAC) | 140 |
| GSM Measurement Personality (Option BAH) | 148 |
| General | 155 |
| Inputs and Outputs | 160 |
| Front Panel | 160 |
| Rear Panel | 161 |
| Regulatory Information | 167 |
| Declaration of Conformity | 168 |

4. Agilent E4405B Specifications and Characteristics

| | |
|---|-----|
| About This Chapter | 170 |
| Frequency | 172 |
| Amplitude | 180 |
| Options | 193 |
| Time Gated Spectrum Analysis (Option 1D6) | 193 |
| Tracking Generator (Option 1DN) | 194 |
| Bluetooth FM Demodulation (Option 106) | 198 |
| Bluetooth Measurements Personality (Option 228) | 199 |
| FM Demodulation (Option BAA) | 202 |
| TV Trigger and Picture On Screen (Option B7B) | 203 |
| cdmaOne Measurement Personality (Option BAC) | 204 |
| GSM Measurement Personality (Option BAH) | 212 |
| General | 219 |
| Inputs and Outputs | 224 |
| Front Panel | 224 |
| Rear Panel | 225 |
| Regulatory Information | 231 |
| Declaration of Conformity | 232 |

5. Agilent E4407B Specifications and Characteristics

| | |
|---|-----|
| About This Chapter | 234 |
| Frequency | 236 |
| Amplitude | 244 |
| Options | 259 |
| Time Gated Spectrum Analysis (Option 1D6) | 259 |
| Tracking Generator (Option 1DN) | 260 |
| External Mixing (Option AYZ) | 264 |
| Bluetooth FM Demodulation (Option 106) | 266 |
| Bluetooth Measurements Personality (Option 228) | 267 |
| FM Demodulation (Option BAA) | 270 |
| TV Trigger and Picture On Screen (Option B7B) | 271 |
| cdmaOne Measurement Personality (Option BAC) | 272 |
| GSM Measurement Personality (Option BAH) | 281 |
| General | 288 |
| Inputs and Outputs | 293 |
| Front Panel | 293 |
| Rear Panel | 295 |
| Regulatory Information | 301 |
| Declaration of Conformity | 302 |

About This Chapter

This chapter contains specifications and characteristics for the Agilent E4401B spectrum analyzer. The distinction between specifications and characteristics is described as follows.

- Specifications describe the performance of parameters covered by the product warranty. (The temperature range is 0 °C to 55 °C, unless otherwise noted.)
- Characteristics describe product performance that is useful in the application of the product, but is not covered by the product warranty.
- Typical performance describes additional product performance information that is not covered by the product warranty. It is performance beyond specification that 80% of the units exhibit with a 95% confidence level over the temperature range 20 to 30 °C. Typical performance does not include measurement uncertainty.
- Nominal values indicate the expected performance, or describe product performance that is useful in the application of the product, but is not covered by the product warranty.

The following conditions must be met for the analyzer to meet its specifications.

- o The analyzer is within the one year calibration cycle.
- o If **Auto Align All** is selected:
 - After 2 hours of storage within the operating temperature range.
 - 5 minutes after the analyzer is turned on with sweep times less than 4 seconds.
- o If **Auto Align Off** is selected:
 - When the analyzer is at a constant temperature, within the operating temperature range, for a minimum of 90 minutes.
 - After the analyzer is turned on for a minimum of 90 minutes and **Align Now All** has been run.
 - When **Align Now All** is run:
 - Every hour
 - If the ambient temperature changes more than 3 °C
 - If the 10 MHz reference changes

- o If **Auto Align All but RF** is selected:
 - When the analyzer is at a constant temperature, within the operating temperature range, for a minimum of 90 minutes.
 - After the analyzer is turned on for a minimum of 90 minutes and **Align Now RF** has been run.
 - When **Align Now RF** is run:
 - Every hour
 - If the ambient temperature changes more than 3 °C

Frequency

| | Specifications | Supplemental Information |
|--|--------------------|--------------------------|
| Frequency Range | | |
| 50 Ω | 9 kHz to 1.5 GHz | |
| 50 Ω , Preamp On (<i>Option IDS</i>) | 100 kHz to 1.5 GHz | |
| 75 Ω (<i>Option IDP</i>) | 1 MHz to 1.5 GHz | |
| 75 Ω , Preamp On (<i>Option IDS, IDP</i>) | 1 MHz to 1.5 GHz | |

| | Specifications | Supplemental Information |
|----------------------------|------------------------------|---|
| Frequency Reference | | |
| Aging Rate | $\pm 2 \times 10^{-6}$ /year | $\pm 1.0 \times 10^{-7}$ /day, characteristic |
| Settability | $\pm 5 \times 10^{-7}$ | |
| Temperature Stability | $\pm 5 \times 10^{-6}$ | |

| | Specifications | Supplemental Information |
|---|------------------------------|---|
| High Stability Frequency Reference (<i>Option ID5</i>) | | |
| Aging Rate | $\pm 1 \times 10^{-7}$ /year | $\pm 5 \times 10^{-10}$ /day, 7-day average after being powered on for 7 days, characteristic |
| Settability | $\pm 1 \times 10^{-8}$ | |
| Temperature Stability | | |
| 20 to 30 $^{\circ}\text{C}$ | $\pm 1 \times 10^{-8}$ | |
| 0 to 55 $^{\circ}\text{C}$ | $\pm 5 \times 10^{-8}$ | |
| Warm-up (Internal frequency reference selected) | | |
| After 5 minutes | | $< \pm 1 \times 10^{-7}$ of final frequency, ^a characteristic |
| After 15 minutes | | $< \pm 1 \times 10^{-8}$ of final frequency, ^a characteristic |

a. Final frequency is defined as frequency 60 minutes after power-on with analyzer set to internal frequency reference.

| | Specifications | Supplemental Information |
|--|--|---------------------------------|
| Frequency Readout Accuracy (Start, Stop, Center, Marker) | $\pm((\text{frequency indication} \times \text{frequency reference error}^a)$ $+ 0.5\% \text{ of span}$ $+ \frac{\text{span}}{\text{sweep points} - 1}$ $+ 15\% \text{ of RBW}$ $+ 10 \text{ Hz})$ | |

a. Frequency reference error = (aging rate × period of time since adjustment + settability + temperature stability).

| | Specifications | Supplemental Information |
|---------------------------------|--|---------------------------------|
| Marker Frequency Counter | | |
| Resolution | Selectable from 1 Hz to 100 kHz | |
| Accuracy ^a | $\pm(\text{marker frequency} \times \text{frequency reference error}^b + \text{counter resolution})$ | For RBW ≥ 1 kHz |

a. Marker level to displayed noise level > 25 dB, RBW/ Span ≥ 0.002, frequency offset = 0 Hz.

b. Frequency reference error = (aging rate × period of time since adjustment + settability + temperature stability).

| | Specifications | Supplemental Information |
|-----------------------|--|---------------------------------|
| Frequency Span | | |
| Range | 0 Hz (zero span), 100 Hz to 1.5 GHz | |
| Resolution | 2 Hz | |
| Accuracy ^a | $\pm(0.5\% \text{ of span}$ $+ 2 \times \frac{\text{span}}{\text{sweep points} - 1})$ | |

a. Applies to each sweep segment.

| | Specifications | Supplemental Information |
|--|--------------------------------|---|
| Sweep Time | | |
| Range | | |
| Span > 0 Hz | 1 ms to 4000 s ^a | $\frac{\text{sweep points} - 1}{100 \text{ kHz}}$ to 4000 s |
| Span = 0 Hz | 10 μs to 4000 s ^{a,b} | |
| Tracking Generator On (Option 1DN or 1DQ) | | 50 ms is the minimum sweep time |

Agilent E4401B Specifications and Characteristics
Frequency

| | Specifications | Supplemental Information |
|--|--|---|
| Fast Time-domain Sweep (<i>Option AYX</i>) (For Span = 0 Hz, RBW ≥ 1 kHz) | 50 ns to 4000 s ^{c,d} | $\frac{\text{sweep points} - 1}{20 \text{ MHz}}$ to 4000 s |
| Accuracy (Span = 0 Hz) | | |
| 10 μs to 4000 s ^{a,b} | ±1% | |
| (<i>Option AYX</i>) | ±1% | |
| 50 ns to 4000 s ^{c,d} | | |
| Sweep Trigger ^{e,f} | Free Run, Single, Line, Video ^g , External, Delayed, Offset ^h | |
| (<i>Option 1D6</i>) | Add Gate | |
| (<i>Option B7B</i>) | Add TV | |
| Delayed Trigger ^{f,i} | | |
| Range | 1 μs to 400 s | |
| Resolution | $\frac{\text{delay in seconds}}{65000}$ rounded up to nearest μs | |
| Accuracy | ±(500 ns + (0.01% of delay)) | |
| Offset Trigger ^h | | |
| Resolution | $\frac{\text{sweep time}}{\text{sweep points} - 1}$ | |
| Range | ±327 ms to ±12.3 ks | Where ST = sweep time and SP = sweep points $\frac{-32766 \times \text{ST}}{\text{SP} - 1}$ to $\frac{(32766 - \text{SP}) \times \text{ST}}{\text{SP} - 1}$ |
| Fast Time-domain sweep (<i>Option AYX</i>) (For sweep times $\frac{\text{sweep points} - 1}{20 \text{ MHz}}$ to $\frac{\text{sweep points} - 1}{100 \text{ kHz}}$) | ±1.23 ms to ±245 ms | $\frac{-32766 \times \text{ST}}{\text{SP} - 1}$ to $\frac{(32766 - \text{SP}) \times \text{ST}}{\text{SP} - 1}$ |

- a. For firmware revisions prior to A.04.00, 5 ms to 2000 s.
- b. For firmware revisions prior to A.05.00, 1 ms to 4000 s.
- c. For firmware revisions prior to A.04.00, 20 μs to 2000 s.
- d. For firmware revisions prior to A.05.00, 5 μs to 4000 s.
- e. Gate cannot be used simultaneously with delayed or TV trigger (*Option B7B*).
- f. Auto align is suspended in video, external, gate, and delayed trigger modes while waiting for a trigger event to occur.
- g. Unavailable when RBW ≤ 300 Hz (*Option 1DR*).
- h. For firmware revision A.04.00 or later.
- i. Delayed trigger is available with line, external trigger, and TV trigger (*Option B7B*).

| | Specifications | Supplemental Information |
|-----------------------------|--------------------------|--------------------------|
| Sweep (trace) Points | | |
| Range | | |
| Span > 0 Hz | 101 to 8192 ^a | |
| Span = 0 Hz | 2 to 8192 ^{a,b} | |

a. For firmware revisions prior to A.04.00, 401 points.

b. For firmware revisions prior to A.05.00, 101 to 8192 points.

| | Specifications | Supplemental Information |
|--|---|---|
| Resolution Bandwidth (RBW) | | |
| Range | | |
| -3 dB bandwidth | 1 kHz to 3 MHz, in 1-3-10 sequence, 5 MHz | |
| -6 dB bandwidth (EMI) | 9 kHz and 120 kHz | |
| <i>(Option IDR)</i> | | |
| -3 dB bandwidth | Adds 10, 30, 100, 300 Hz | Only available in spans ≤ 5 MHz, sweep times $\geq \frac{\text{sweep points} - 1}{100 \text{ kHz}}$, |
| -6 dB bandwidth (EMI) | Add 200 Hz | and not usable with tracking generator on. (<i>Option IDN or Option IDQ</i>) |
| Accuracy | | |
| 1 kHz to 3 MHz RBW | ±15% | |
| 5 MHz RBW | ±30% | |
| Shape | | |
| 1 kHz to 5 MHz RBW | | Synchronously tuned four poles, approximately Gaussian shape |
| 10 Hz to 300 Hz RBW <i>(Option IDR)</i> | | Digital, approximately Gaussian shape |
| Selectivity (60 dB/3 dB bandwidth ratio) | | |
| 1 kHz to 5 MHz RBW | | <15:1, characteristic |
| 10 Hz to 300 Hz RBW <i>(Option IDR)</i> | | <5:1, characteristic |

Agilent E4401B Specifications and Characteristics
Frequency

| | Specifications | Supplemental Information |
|--------------------------------------|-----------------------------------|--|
| Video Bandwidth (VBW) (-3 dB) | | |
| Range | 30 Hz to 1 MHz in 1-3-10 sequence | 3 MHz, characteristic |
| (Option 1DR) | Adds 1, 3, 10 Hz for RBW's <1 kHz | |
| Accuracy | | ±30%, characteristic |
| Shape | | Post detection, single pole low-pass filter used to average displayed noise Video bandwidths below 30 Hz are digital bandwidths with anti-aliasing filtering. |

| | Specifications | Supplemental Information |
|--|-----------------------|-------------------------------------|
| Stability | | |
| Noise Sidebands (Offset from CW signal with 1 kHz RBW, 30 Hz VBW and sample detector) | | |
| ≥1 kHz (Option 1DR, 1D5) | | ≤ -79 dBc/Hz, typical |
| ≥10 kHz | ≤ -93 dBc/Hz | ≤ -95 dBc/Hz, typical |
| ≥20 kHz | ≤ -100 dBc/Hz | ≤ -102 dBc/Hz, typical |
| ≥30 kHz | ≤ -104 dBc/Hz | ≤ -106 dBc/Hz, typical |
| ≥100 kHz | ≤ -113 dBc/Hz | ≤ -116 dBc/Hz, typical |
| Residual FM | | |
| 1 kHz RBW, 1 kHz VBW | ≤150 Hz p-p in 100 ms | |
| (Option 1D5) | ≤100 Hz p-p in 100 ms | |
| 10 Hz RBW, 10 Hz VBW | ≤2 Hz p-p in 20 ms | |
| (Option 1DR and 1D5) | | |
| 10 Hz RBW, 10 Hz VBW | | ≤10 Hz p-p in 20 ms, characteristic |
| (Option 1DR) | | |
| System-Related Sidebands, offset from CW signal | | |
| ≥30 kHz | ≤ -65 dBc | |

| | Specifications | Supplemental Information |
|---|----------------|--------------------------------|
| Line-Related Sidebands, offset from CW signal (<i>Option 1DR</i>) | | |
| <300 Hz | | ≤ -50 dBc, characteristic |
| >300 Hz to 30 kHz | | ≤ -55 dBc, characteristic |

Noise Sidebands Normalized to 1 Hz Versus Offset from Carrier

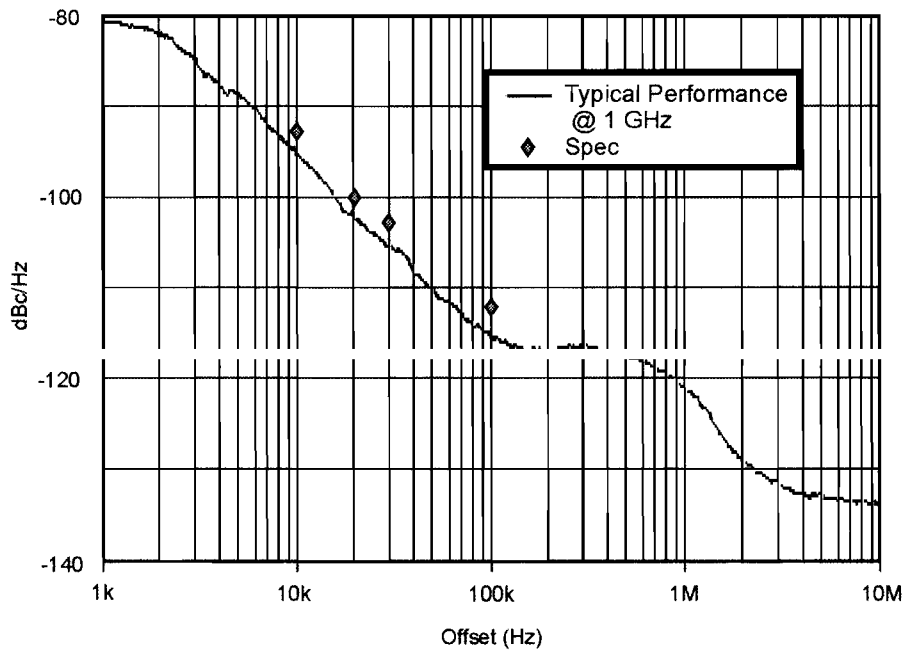

w720b

Amplitude

Amplitude specifications do not apply for the negative peak detector mode.

| | Specifications | Supplemental Information |
|--------------------------|---|--------------------------|
| Measurement Range | Displayed Average Noise Level to Maximum Safe Input Level | |
| Input Attenuator Range | 0 to 60 dB, in 5 dB steps | |

| | Specifications | Supplemental Information |
|--|------------------|---|
| Maximum Safe Input Level | | |
| Input attenuator setting ≥ 15 dB | | Signals $> +33$ dBm (2 W) or $+79$ dBmV (1 W) (<i>Option 1DP</i>) nominal may trigger input protection, which disconnects the input path. |
| Average Continuous Power or Peak Pulse Power | | |
| 50 Ω | +30 dBm (1 W) | |
| 75 Ω (<i>Option 1DP</i>) | +75 dBmV (0.4 W) | |
| dc | 100 Vdc | dc transients may momentarily trigger input protection. |
| Input attenuator setting < 15 dB | | Signals $> +6$ dBm (4 mW) or $+61$ dBmV (15 mW) (<i>Option 1DP</i>) nominal may trigger input protection, which automatically increases input attenuation to 15 dB. |
| Average Continuous Power or Peak Pulse Power | | |
| 50 Ω | +3 dBm (2 mW) | |
| 75 Ω (<i>Option 1DP</i>) | +59 dBmV (10 mW) | |
| dc | 100 Vdc | dc transients may trigger input protection. |

| | Specifications | Supplemental Information |
|---|----------------|--------------------------|
| 1 dB Gain Compression | | |
| Total power at input mixer ^{a,b} | | |
| 50 MHz to 1.5 GHz | | |
| 50 Ω | 0 dBm | |
| 75 Ω (<i>Option 1DP</i>) | +46.75 dBmV | |

| | Specifications | Supplemental Information |
|--|----------------|-----------------------------|
| Preamp On (<i>Option 1DS</i>) Total power at the preamp ^c | | |
| 50 Ω | | -20 dBm, characteristic |
| 75 Ω | | +26.75 dBmV, characteristic |

- a. Mixer power level (dBm) = input power (dBm) – input attenuation (dB).
- b. For resolution bandwidths 1 kHz to 30 kHz, the maximum input signal amplitude must be ≤ reference level +10 dB. (*Option 1DP: For resolution bandwidths 1 kHz to 30 kHz, the maximum input signal amplitude must be ≤ reference level +5 dB.*)
- c. Total power at the preamp = total power at the input (dBm).

| | Specifications | | Supplemental Information | |
|---|------------------------|--|-------------------------------------|---|
| Displayed Average Noise Level (Input terminated, 0 dB attenuation, sample detector, Reference Level = -70 dBm) (75 Ω: Reference Level = -21.24 dBmV) | | | | |
| 50 Ω | 1 kHz RBW 30 Hz VBW | 10 Hz RBW 1 Hz VBW (<i>Option 1DR</i>) | 1 kHz RBW 30 Hz VBW (typical) | 10 Hz RBW 1 Hz VBW (<i>Option 1DR</i>) (typical) |
| 400 kHz to 10 MHz | ≤ -115 dBm | ≤ -134 dBm | ≤ -119 dBm | ≤ -139 dBm |
| 10 MHz to 500 MHz | ≤ -119 dBm | ≤ -138 dBm | ≤ -121 dBm | ≤ -141 dBm |
| 500 MHz to 1.0 GHz | ≤ -117 dBm | ≤ -136 dBm | ≤ -121 dBm | ≤ -140 dBm |
| 1.0 GHz to 1.5 GHz | ≤ -114 dBm | ≤ -133 dBm | ≤ -118 dBm | ≤ -138 dBm |
| 50 Ω, Preamp On (<i>Option 1DS</i>) | 1 kHz RBW 30 Hz VBW | 10 Hz RBW 1 Hz VBW (<i>Option 1DR</i>) | 1 kHz RBW 30 Hz VBW (typical) | 10 Hz RBW 1 Hz VBW (<i>Option 1DR</i>) (typical) |
| 400 kHz to 10 MHz | ≤ -131 dBm | ≤ -150 dBm | ≤ -135 dBm | ≤ -155 dBm |
| 10 MHz to 500 MHz | ≤ -135 dBm | ≤ -154 dBm | ≤ -136 dBm | ≤ -156 dBm |
| 500 MHz to 1.0 GHz | ≤ -133 dBm | ≤ -152 dBm | ≤ -136 dBm | ≤ -156 dBm |
| 1.0 GHz to 1.5 GHz | ≤ -131 dBm | ≤ -150 dBm | ≤ -135 dBm | ≤ -155 dBm |
| 75 Ω, (<i>Option 1DP</i>) | 1 kHz RBW 30 Hz VBW | 10 Hz RBW 1 Hz VBW (<i>Option 1DR</i>) | 1 kHz RBW 30 Hz VBW (typical) | 10 Hz RBW 1 Hz VBW (<i>Option 1DR</i>) (typical) |
| 1 MHz to 10 MHz | ≤ -64 dBmV | ≤ -83 dBmV | ≤ -69 dBmV | ≤ -89 dBmV |
| 10 MHz to 500 MHz | ≤ -66 dBmV | ≤ -85 dBmV | ≤ -70 dBmV | ≤ -90 dBmV |
| 500 MHz to 1.0 GHz | ≤ -60 dBmV | ≤ -79 dBmV | ≤ -66 dBmV | ≤ -85 dBmV |
| 1.0 GHz to 1.5 GHz | ≤ -56 dBmV | ≤ -75 dBmV | ≤ -62 dBmV | ≤ -81 dBmV |

Agilent E4401B Specifications and Characteristics
Amplitude

| | Specifications | | Supplemental Information | |
|---|------------------------|--|-------------------------------------|---|
| 75 Ω , Preamp On (<i>Option 1DP and 1DS</i>) | 1 kHz RBW 30 Hz VBW | 10 Hz RBW 1 Hz VBW (<i>Option 1DR</i>) | 1 kHz RBW 30 Hz VBW (typical) | 10 Hz RBW 1 Hz VBW (<i>Option 1DR</i>) (typical) |
| 1 MHz to 10 MHz | ≤ -80 dBmV | ≤ -99 dBmV | ≤ -83 dBmV | ≤ -103 dBmV |
| 10 MHz to 500 MHz | ≤ -81 dBmV | ≤ -100 dBmV | ≤ -84 dBmV | ≤ -104 dBmV |
| 500 MHz to 1.0 GHz | ≤ -81 dBmV | ≤ -100 dBmV | ≤ -84 dBmV | ≤ -104 dBmV |
| 1.0 GHz to 1.5 GHz | ≤ -75 dBmV | ≤ -94 dBmV | ≤ -80 dBmV | ≤ -100 dBmV |

| | Specifications | Supplemental Information |
|---|---|--------------------------|
| Display Range | | |
| Log Scale | Ten divisions displayed; 0.1, 0.2, 0.5 dB/division and 1 to 20 dB/division in 1 dB steps | |
| RBW \geq 1 kHz | Calibrated 0 to -85 dB from Reference Level | |
| RBW \leq 300 Hz (<i>Option 1DR</i>) | Calibrated 0 to -120 dB ^a from Reference Level | |
| Linear Scale | Ten divisions | |
| Scale Units | dBm, dBmV, dB μ V, dB μ A, A, V, and W | |
| (<i>Option BAA</i>) | Add Hz | |

a. 0 to -70 dB range when span = 0 Hz, or when IF Gain fixed:
(:DISPlay:WINDow:TRACe:Y[:SCALe]:LOG:RANGe:AUTO OFF).

| | Specifications | Supplemental Information |
|---|--------------------------|--------------------------|
| Marker Readout Resolution | | |
| Log scale | | |
| RBW \geq 1 kHz | | |
| 0 to -85 dB from ref level | 0.04 dB | |
| RBW \leq 300 Hz (<i>Option 1DR</i>) | | |
| 0 to -120 dB from ref level | 0.04 dB | |
| Linear scale | 0.01% of Reference Level | |

| | Specifications | Supplemental Information |
|---|--|--------------------------|
| Fast Sweep Times for Zero Span <i>(Option AYX)^a</i> For sweep times $\frac{\text{sweep points} - 1}{20 \text{ MHz}}$ to $\frac{\text{sweep points} - 1}{100 \text{ kHz}}$ Log 0 to -85 dB from ref level Linear | 0.3 dB 0.3% of Reference Level for linear scale | |

a. For firmware revisions prior to A.04.00, 20 μ s to <5 ms.

| | Specifications | Supplemental Information |
|--|--|--|
| Frequency Response^a 50 Ω 9 kHz to 1.5 GHz 10 dB attenuation 20 to 30 $^{\circ}$ C 0 to 55 $^{\circ}$ C 0 dB, 5 dB, 15 to 60 dB attenuation 50 Ω Preamp On (<i>Option IDS</i>) 100 kHz to 1.5 GHz 0 dB attenuation 20 to 30 $^{\circ}$ C 0 to 55 $^{\circ}$ C 5 dB to 20 dB attenuation | ± 0.5 dB ± 1.0 dB ± 1.0 dB ± 1.5 dB ± 1.5 dB | ± 1.0 dB, characteristic ± 1.5 dB, characteristic |

| | Specifications | Supplemental Information |
|-------------------------------------|----------------|---|
| Preamp (<i>Option 1DS</i>) | | Refer also to Displayed Average Noise Level specification |
| Gain | | +20 dB, nominal ^a |
| Noise figure | | 4 dB, characteristic |

a. Amplifier is before the input attenuator.

| | Specifications | Supplemental Information |
|---|--|--------------------------|
| Absolute Amplitude Accuracy | | |
| At reference settings ^a | ± 0.30 dB | ± 0.10 dB, typical |
| Preamp On ^b (<i>Option 1DS</i>) | ± 0.37 dB | ± 0.14 dB, typical |
| Overall Amplitude Accuracy^c | | |
| 20 to 30 °C | $\pm (0.54 \text{ dB} + \text{Absolute Frequency Response})$ | |

a. Settings are: reference level -25 dBm; (75Ω reference level $+28.75$ dBmV); input attenuation 10 dB; center frequency 50 MHz; RBW 1 kHz; VBW 1 kHz; scale linear or log; span 2 kHz; sweep time coupled, sample detector, signal at reference level.

b. Settings are: reference level -30 dBm; (75Ω reference level $+18.75$ dBmV); input attenuation 0 dB; center frequency 50 MHz; RBW 1 kHz; VBW 1 kHz; scale linear or log; span 2 kHz; sweep time coupled, signal at reference level.

c. For reference level 0 to -50 dBm; input attenuation 10 dB; RBW 1 kHz; VBW 1 kHz; scale log, log range 0 to -50 dB from reference level; sweep time coupled; signal input 0 to -50 dBm; span ≤ 20 kHz.

| | Specifications | Supplemental Information |
|---|----------------|--------------------------------|
| RF Input VSWR (at tuned frequency) | | |
| Attenuator setting | | |
| 50 Ω | | |
| 0 to 5 dB attenuation | | $\leq 1.55:1$, characteristic |
| 10 to 60 dB attenuation | | $\leq 1.35:1$, characteristic |
| 75 Ω | | |
| 1 MHz to 1.1 GHz | | |
| 0 to 5 dB attenuation | | $\leq 1.55:1$, characteristic |
| 10 to 60 dB attenuation | | $\leq 1.35:1$, characteristic |

| | Specifications | Supplemental Information |
|--|----------------|--|
| 1.1 GHz to 1.5 GHz 0 to 60 dB attenuation Input protection is tripped Amptd Ref is On Auto Align All is selected | | $\leq 2.0:1$, characteristic Open input, characteristic Open input, characteristic Open input momentarily during retrace, characteristic |

| | Specifications | Supplemental Information |
|---|----------------|------------------------------|
| Auto Alignment^a Sweep-to-sweep variation | | ± 0.1 dB, characteristic |

a. Set **Auto Align** to **Off** and use **Align Now, All** to eliminate this variation.

| | Specifications | Supplemental Information |
|--|---|--------------------------|
| Resolution Bandwidth Switching Uncertainty (at Reference Level) 1 kHz RBW 3 kHz to 3 MHz RBW 5 MHz RBW 10 Hz to 300 Hz RBW <i>(Option 1DR)</i> | Reference ± 0.3 dB ± 0.6 dB ± 0.3 dB | |

| | Specifications | Supplemental Information |
|--|---|--------------------------|
| Reference Level Range Resolution Log Scale Linear Scale | -149.9 dBm to maximum mixer level + attenuator setting ± 0.1 dB $\pm 0.12\%$ of Reference Level | |

| | Specifications | Supplemental Information |
|--|---|--------------------------|
| <p>50 Ω, Accuracy (at a fixed frequency, a fixed attenuator, and referenced to -35 dBm (-10 dBm, Preamp On (Option 1DS)))</p> <p>Reference Level (dBm) – input attenuator setting (dB) + preamp gain (dB)</p> <p>-10 dBm to > -60 dBm</p> <p>-60 dBm to > -85 dBm</p> <p>-85 dBm to -90 dBm</p> <p>75 Ω (Option 1DP), Accuracy (at a fixed frequency, a fixed attenuator, and referenced to 18.75 dBmV (38.75 dBmV, Preamp On (Option 1DS)))</p> <p>Reference Level (dBmV) – input attenuator setting (dB) + preamp gain (dB)</p> <p>38.75 dBmV to > -11.25 dBmV</p> <p>-11.25 dBmV to > -26.25 dBmV</p> <p>-26.25 dBmV to -41.25 dBmV</p> | <p>± 0.3 dB</p> <p>± 0.5 dB</p> <p>± 0.7 dB</p> <p>± 0.3 dB</p> <p>± 0.5 dB</p> <p>± 0.7 dB</p> | |

| | Specifications | Supplemental Information |
|--|--|--------------------------|
| <p>Display Scale Switching Uncertainty</p> <p>Switching between Linear and Log</p> <p>Log Scale Switching</p> | <p>± 0.15 dB at reference level</p> <p>No error</p> | |

| | Specifications | Supplemental Information |
|---|---|---------------------------------|
| Display Scale Fidelity | | |
| Log Maximum Cumulative | | |
| RBW \geq 1 kHz | | |
| dB Below Reference Level | | |
| 0 dB Reference | 0 dB | |
| > 0 to 10 dB | ± 0.22 dB | ± 0.08 dB, typical |
| > 10 to 20 dB | ± 0.24 dB | ± 0.09 dB, typical |
| > 20 to 30 dB | ± 0.26 dB | ± 0.10 dB, typical |
| > 30 to 40 dB | ± 0.40 dB | ± 0.23 dB, typical |
| > 40 to 50 dB | ± 0.57 dB | ± 0.35 dB, typical |
| > 50 to 60 dB | ± 0.57 dB | ± 0.35 dB, typical |
| > 60 to 70 dB | ± 0.66 dB | ± 0.39 dB, typical |
| >70 to 80 dB | ± 0.66 dB | ± 0.46 dB, typical |
| >80 to 85 dB | ± 1.15 dB | ± 0.79 dB, typical |
| RBW \leq 300 Hz (<i>Option 1DR</i>) | | |
| Span > 0 Hz | | |
| Auto range On | | |
| 0 to 98 dB below reference level | $\pm(0.3 \text{ dB} + 0.01 \times \text{dB from reference level})$ | |
| > 98 to 120 dB below reference level | | ± 2.0 dB, characteristic |
| Auto range Off | | |
| 0 to 60 dB below reference level | $\pm(0.3 \text{ dB} + 0.015 \times \text{dB from reference level})$ | |
| > 60 to 70 dB below reference level | ± 1.5 dB | |
| Span = 0 Hz ^a | | |
| 0 to 60 dB below reference level | $\pm(0.3 \text{ dB} + 0.015 \times \text{dB from reference level})$ | |
| > 60 to 70 dB below reference level | ± 1.5 dB | |

| | Specifications | Supplemental Information |
|---|------------------------------|--------------------------|
| Log Incremental Accuracy | | |
| 0 to 80 dB ^b below reference level | ± 0.4 dB/4 dB | |
| Linear Accuracy | $\pm 2\%$ of Reference Level | |

- The SCPI command for auto range off is:
(:DISPlay:WINDow:TRACe:Y[:SCALe]:LOG:RANGe:AUTO OFF)
- 0 to -50 dB for RBWs \leq 300 Hz and span = 0 Hz, or when auto ranging is off.

| | Specifications | Supplemental Information |
|---|---|--|
| Spurious Responses | | |
| 50 Ω | | |
| Second Harmonic Distortion | | |
| Input Signal | | |
| 2 MHz to 750 MHz | < -75 dBc for -40 dBm signal at input mixer ^a | +35 dBm SHI (second harmonic intercept) |
| Preamp On (<i>Option IDS</i>), 2 MHz to 750 MHz | | +35 dBm SHI, characteristic |
| Third Order Intermodulation Distortion | | |
| 2 MHz to 10 MHz | | +14.5 dBm TOI (third order intercept), typical |
| 10 MHz to 1.5 GHz | < -87 dBc ^b for two -30 dBm signals at input mixer ^a and > 50 kHz separation. | +13.5 dBm ^b TOI +19 dBm TOI, typical |
| Preamp On (<i>Option IDS</i>), 10 MHz to 1.5 GHz | | -16 dBm TOI, characteristic |
| Other Input Related Spurious | | |
| 30 kHz \leq offset \leq 1200 MHz | < -65 dBc for -20 dBm signals at input mixer ^a \leq 1.5 GHz. | |
| Offset > 1200 MHz | < -45 dBc for -20 dBm signal at input mixer ^a \leq 1.5 GHz. | |
| Noise Floor Degradation | | |
| Input frequency = 1210.7 MHz \pm RBW | | < -62 dBc for -45 dBm signal at input mixer ^a |

- Mixer Power Level (dBm) = Input Power (dBm) - Input Attenuation (dB).
- For serial numbers $<$ US39440413, < -80 dBc for two -30 dBm signals at the input mixer and > 50 kHz separation. +10 dBm TOI, +15 dBm, typical.

| | Specifications | Supplemental Information |
|---|---|---|
| Spurious Responses | | |
| <i>75 Ω, (Option 1DP)</i> | | |
| Second Harmonic Distortion Input signal | | |
| 2 MHz to 750 MHz | < -75 dBc for +8.75 dBmV signal at input mixer ^a | |
| Preamp On (<i>Option 1DS</i>), 2 MHz to 750 MHz | | < -40 dBc for +8.75 dBmV signal at the Input with 0 dB input attenuation, characteristic |
| Third Order Intermodulation Distortion | | |
| 10 MHz to 1.5 GHz | < -80 dBc for two +18.75 dBmV signals at input mixer ^a and >50 kHz separation. | |
| Preamp On (<i>Option 1DS</i>), 10 MHz to 1.5 GHz | | < -28 dBc for two +18.75 dBmV signals at the Input with 0 dB input attenuation and > 50 kHz separation, characteristic |
| Other Input Related Spurious | | |
| 30 kHz ≤ offset ≤1200 MHz | < -65 dBc for +28.75 dBmV signal at input mixer ^a ≤1.5 GHz. | |
| Offset >1200 MHz | < -45 dBc, for +28.75 dBmV signal at input mixer ^a ≤1.5 GHz. | |
| Noise Floor Degradation | | |
| Input frequency = 1210.7 MHz ± RBW | | < -62 dBc, for +3.75 dBmV signal at input mixer ^a |

a. Mixer Power Level (dBmV) = Input Power (dBmV) – Input Attenuation (dB)

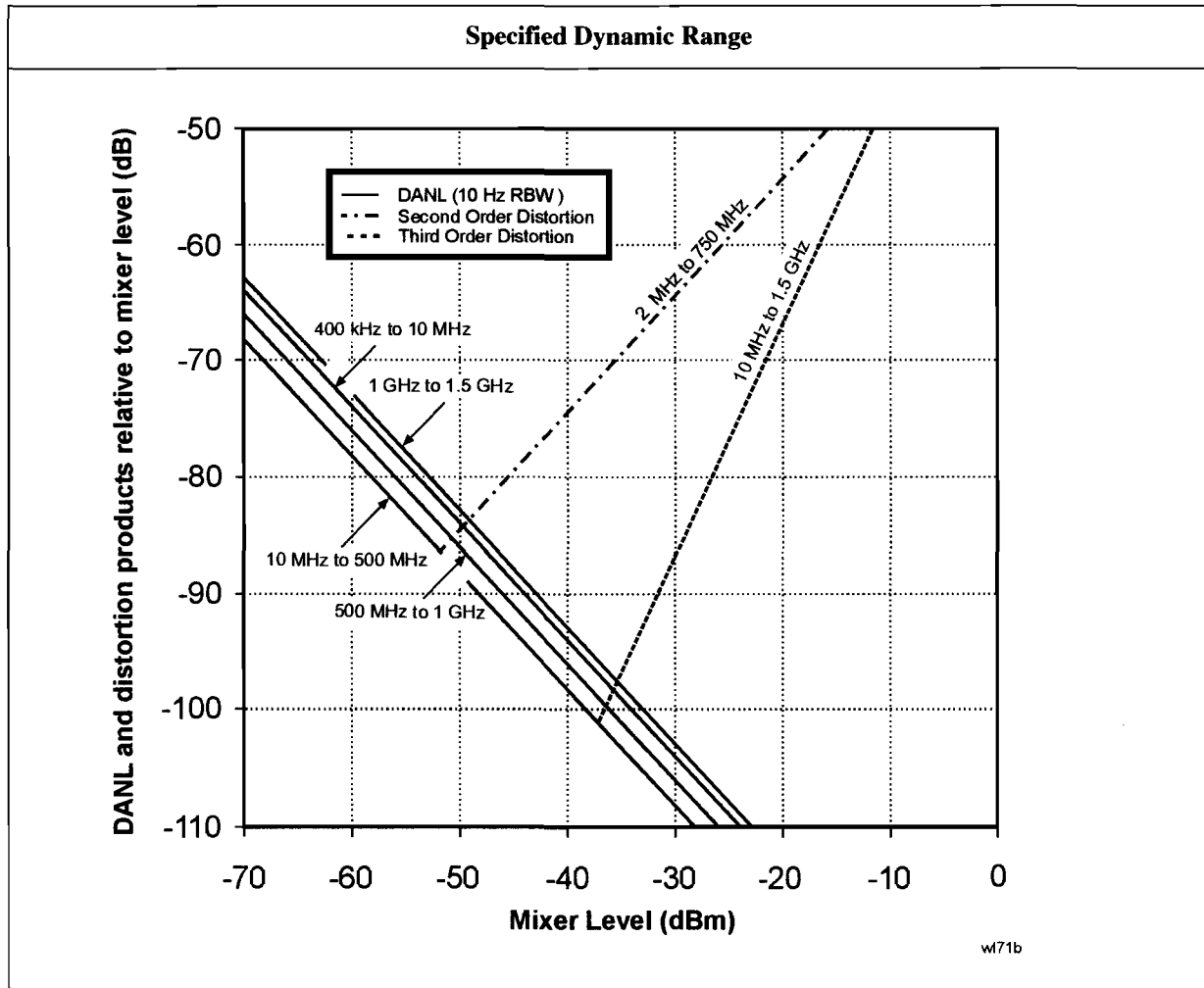

| | Specifications | Supplemental Information |
|--|---------------------------------|--------------------------|
| Residual Responses (Input terminated and 0 dB attenuation) 50 Ω 150 kHz to 1.5 GHz 75 Ω , (Option 1DP) 1 MHz to 1.5 GHz | < -90 dBm < -36 dBmV | |

Options

Time Gated Spectrum Analysis (Option 1D6)

| | Specifications | Supplemental Information |
|---|---|---|
| Gate Delay | | |
| Range | 1 μ s to 400 s | |
| Accuracy | $\pm(500 \text{ ns} + (0.01\% \times (\text{maximum of gate delay or length})))$ | From gate trigger input to positive edge of gate output |
| Gate Length | | |
| Range | 1 μ s to 400 s | |
| Accuracy | $\pm(500 \text{ ns} + (0.01\% \times (\text{maximum of gate delay or length})))$ | From positive edge to negative edge of gate output |
| Resolution | $((\text{maximum of gate delay or length in seconds})/65000)$ rounded up to nearest μ s | Dependent on the greater of gate delay or gate length |
| Additional Amplitude Error^a | | |
| Log Scale | $\pm 0.2 \text{ dB}$ | |
| Linear Scale | $\pm 0.1\%$ of reference level | |

a. While in gate mode.

Tracking Generator (Option 1DN or 1DQ)

| | Specifications | Supplemental Information |
|----------------|----------------|--------------------------|
| Warm-up | 5 minutes | |

| | Specifications | Supplemental Information |
|-------------------------------|------------------|--------------------------|
| Output Frequency Range | | |
| 50 Ω (Option 1DN) | 9 kHz to 1.5 GHz | |
| 75 Ω (Option 1DQ) | 1 MHz to 1.5 GHz | |

| | Specifications | Supplemental Information |
|------------------------------|----------------|--|
| Minimum Resolution BW | 1 kHz | Not usable with resolution bandwidths ≤ 300 Hz (Option 1DR) |

| | Specifications | Supplemental Information |
|--|-----------------------|--------------------------|
| Output Power Level | | |
| Range | | |
| 50 Ω (Option 1DN) | | |
| 0 to 55 $^{\circ}\text{C}$ | 0 to -70 dBm | |
| 20 to 30 $^{\circ}\text{C}$ | 2 to -70 dBm | |
| 75 Ω (Option 1DQ) | +42.75 to -27.25 dBmV | |
| Resolution | 0.1 dB | |
| Absolute Accuracy (at 50 MHz with coupled source attenuator) | | |
| 50 Ω (Option 1DN) referenced to 0 dBm | ± 0.5 dB | |
| 75 Ω (Option 1DQ) referenced to +42.75 dBmV | ± 1.5 dB | |
| Vernier | | |
| Range | 10 dB | |

Agilent E4401B Specifications and Characteristics
Options

| | Specifications | Supplemental Information |
|--|---|--------------------------|
| Accuracy (with coupled source attenuator) | | |
| 50 Ω (Option 1DN) referenced to 0 dBm | ± 0.75 dB, for 0 to -10 dBm | |
| 75 Ω (Option 1DQ) referenced to 42.75 dBmV | ± 0.9 dB, for +42.75 to +32.75 dBmV | |
| Output Attenuator Range | 0 to 60 dB in 10 dB steps | |

| | Specifications | Supplemental Information |
|---------------------------------------|----------------|---|
| Maximum Safe Reverse Level | | |
| 50 Ω (Option 1DN) ^a | | +20 dBm (0.1 W), 100 Vdc, characteristic |
| 75 Ω (Option 1DQ) ^a | | +69 dBmV (0.1 W), 100 Vdc, characteristic |

a. dc transients may trigger reverse power protection.

| | Specifications | Supplemental Information |
|---------------------------|---|--------------------------|
| Output Power Sweep | | |
| Range | | |
| 50 Ω (Option 1DN) | (-15 to 0 dBm) – (Source Attenuator Setting) | |
| 75 Ω (Option 1DQ) | (27.75 to 42.75 dBmV) – (Source Attenuator Setting) | |
| Resolution | 0.1 dB | |
| Accuracy (zero span) | | |
| 50 Ω (Option 1DN) | <1.5 dB peak-to-peak | |
| 75 Ω (Option 1DQ) | <1.8 dB peak-to-peak | |

| | Specifications | Supplemental Information |
|---------------------------------------|----------------|--------------------------|
| Output Flatness | | |
| Referenced to 50 MHz, 0 dB attenuator | | |
| 50 Ω (Option 1DN) | | |
| 9 kHz to 10 MHz | ± 2 dB | |
| 10 MHz to 1.5 GHz | ± 1.5 dB | |

| | Specifications | Supplemental Information |
|--|----------------|--------------------------|
| 75 Ω (Option 1DQ) | | |
| 1 MHz to 10 MHz | ± 2.5 dB | |
| 10 MHz to 1.5 GHz | ± 2 dB | |

| | Specifications | Supplemental Information |
|--|----------------|--------------------------|
| Spurious Outputs | | |
| 50 Ω (Option 1DN) (0 dBm output) | | |
| 75 Ω (Option 1DQ) (+42.75 dBmV output) | | |
| Harmonic Spurs | | |
| 9 kHz to 20 MHz | < -20 dBc | |
| 20 MHz to 1.5 GHz | < -25 dBc | |
| Non-harmonic Spurs | < -35 dBc | |

| | Specifications | Supplemental Information |
|----------------------|---|--------------------------|
| Dynamic Range | Maximum Output Power Level – Displayed Average Noise Level | |

| | Specifications | Supplemental Information |
|------------------------|----------------|----------------------------------|
| Output Tracking | | |
| Drift | | No error |
| Swept Tracking Error | | No error for coupled sweep times |

| | Specifications | Supplemental Information |
|--|----------------|----------------------------|
| RF Power-Off Residuals | | |
| 50 Ω (Option 1DN) 100 kHz to 1.5 GHz | | < -120 dBm, characteristic |
| 75 Ω (Option 1DQ) 1 MHz to 1.5 GHz | | < 65 dBmV, characteristic |

Agilent E4401B Specifications and Characteristics
Options

| | Specifications | Supplemental Information |
|--|----------------|--------------------------|
| Output Attenuator Repeatability | | ±0.2 dB, characteristic |

| | Specifications | Supplemental Information |
|--|----------------|--|
| Output VSWR 50 Ω (<i>Option 1DN</i>) 75 Ω (<i>Option 1DQ</i>) | | <2.5:1, characteristic <2.0:1, characteristic |

| | Specifications | Supplemental Information |
|---|----------------|--|
| Output Attenuator Accuracy 0 dB 10 dB 20 dB 30 dB 40 dB 50 dB 60 dB | Reference | ±0.6 dB, characteristic ±0.9 dB, characteristic ±1.2 dB, characteristic ±1.5 dB, characteristic ±1.8 dB, characteristic ±2.1 dB, characteristic |

| Tracking Generator Output Accuracy 50 Ω (Option 1DN) |
|--|
| Relative Accuracy (Referred to 0 dBm) = Output Attenuator Accuracy + Vernier Accuracy + Output Flatness |
| Absolute Accuracy = Relative Accuracy (Referred to 0 dBm) + Absolute Accuracy at 50 MHz |

| Tracking Generator Output Accuracy 75 Ω (Option 1DQ) |
|--|
| Relative Accuracy (Referred to +42.75 dBmV) = Output Attenuator Accuracy + Vernier Accuracy + Output Flatness |
| Absolute Accuracy = Relative Accuracy (Referred to +42.75 dBmV) + Absolute Accuracy at 50 MHz |

FM Demodulation (Option BAA)

The FM demodulation characteristics will apply after an **Align Now, FM Demod** has been run.

| | Specifications | Supplemental Information |
|---|----------------|---|
| Optimum Input Level | | $\geq (-60 \text{ dBm} + \text{attenuator setting} - \text{preamp gain})$ and within 30 dB of the reference level |
| FM Deviation | | |
| Range | | 10 kHz to 1 MHz |
| Resolution | | Provides 1 Hz display annotation resolution |
| FM Deviation Range | | |
| 10 kHz to 40 kHz | | 12 Hz, characteristic |
| >40 kHz to 200 kHz | | 60 Hz, characteristic |
| >200 kHz to 1 MHz | | 300 Hz, characteristic |
| Accuracy ^a | | |
| FM Rate < FM BW/100, VBW $\geq (30 \times \text{FM Rate})$, RBW > the maximum of (30 \times FM deviation) or (30 \times FM Rate) | | < (2% of FM deviation range + 2 \times Resolution), characteristic |
| Offset Error ^a | | 5% of FM Deviation Range + 300 Hz, characteristic |
| FM Bandwidth (-3 dB) | | |
| FM Deviation Range | | |
| 10 kHz to 40 kHz | | 7.5 \times FM deviation range, characteristic |
| >40 kHz to 200 kHz | | 1.3 \times FM deviation range, characteristic |
| >200 kHz to 1 MHz | | 0.3 \times FM deviation range, characteristic |

a. In time domain sweeps (span = 0 Hz).

TV Trigger and Picture On Screen (Option B7B)

Option BAA is required.

| | Specifications | Supplemental Information |
|---|---|--|
| TV Trigger and Picture On Screen | | TV Trigger initiates a sweep of the analyzer after the sync pulse of a selected line of a TV video field. Picture On Screen displays the TV picture on the analyzer display. |
| Amplitude Requirements TV Source: SA | | Top 50% of linear display, characteristic |
| TV Source: EXT VIDEO IN | | 500 mVp-p to 2 Vp-p, characteristic |
| Compatible Standards | NTSC-M, NTSC-Japan, PAL-M, PAL-B,D,G,H,I, PAL-N, PAL-N Combination, SECAM-L | |
| Field Selection | Entire frame, even, odd | |
| Sync Polarity | Positive or negative | |
| TV Trigger | | |
| Line Selection | 1 to 525, or 1 to 625, standard dependent | |

General

| | Specifications | Supplemental Information |
|--------------------------|----------------|--------------------------|
| Temperature Range | | |
| Operating | 0 to 55 °C | Floppy disk 10 to 40 °C |
| Storage | –40 to 75 °C | |

| | Specifications | Supplemental Information |
|-------------------------------------|----------------|----------------------------|
| Audible Noise (ISO 7779) | | |
| Sound Pressure at 25 °C | | <40 dBa, (<4.6 Bels power) |

| | Specifications | Supplemental Information |
|-------------------------------|---|--------------------------|
| Military Specification | Has been type tested to the environmental specifications of MIL-PRF-28800F class 3. | |

| | Specifications | Supplemental Information |
|---------------------------------|---|--------------------------|
| EMI Compatibility | Conducted and radiated emission is in compliance with CISPR Pub. 11/1990 Group 1 Class A. | |
| <i>(Option 060)^a</i> | Conducted and radiated emission is in compliance with CISPR Pub. 11/1990 Group 1 Class B ^b . | |

a. Option 060 is not compatible with Option B7B nor Option 1DP.

b. Meets Class A performance during dc operation.

| | Specifications | Supplemental Information |
|-------------------------|----------------|---|
| Immunity Testing | | |
| Radiated Immunity | | Testing was done at 3 V/m according to IEC 801-3/1984. When the analyzer tuned frequency is identical to the immunity test signal frequency, there may be signals of up to –60 dBm displayed on the screen. |

Agilent E4401B Specifications and Characteristics
General

| | Specifications | Supplemental Information |
|-------------------------|----------------|---|
| Electrostatic Discharge | | Air discharges of up to 8 kV were applied according to IEC 801-2/1991. Discharges to center pins of any of the connectors may cause damage to the associated circuitry. |

| | Specifications | Supplemental Information |
|----------------------------|--|--------------------------|
| Power Requirements | | |
| ac Operation | | |
| Voltage, frequency | 90 to 132 Vrms, 47 to 440 Hz 195 to 250 Vrms, 47 to 66 Hz | |
| Power Consumption, On | <300 W | |
| Power Consumption, Standby | <5 W | |
| dc Operation | | |
| Voltage | 12 to 20 Vdc | |
| Power Consumption | <200 W | |
| Power Consumption, Standby | <100 mW | |

| | Specifications | Supplemental Information |
|--|----------------|--------------------------|
| Measurement Speed | | |
| Local Measurement and Display Update rate ^{a,b} | | |
| Sweep points = 101 | | ≥ 50/s, characteristic |
| Sweep points = 401 | | ≥ 35/s, characteristic |
| Remote Measurement and GPIB Transfer Rate ^{b,c,d} | | |
| <i>(Option A4H)</i> | | |
| Sweep points = 101 | | ≥ 45/s, characteristic |
| Sweep points = 401 | | ≥ 30/s, characteristic |

| | Specifications | Supplemental Information |
|--|----------------|--|
| RF Center Frequency Tune, Measure, and GPIB Transfer Time^{b,c,e} (Option A4H) Sweep points = 101 Sweep points = 401 | | ≤ 75 ms, characteristic ≤ 90 ms, characteristic |

- Factory preset, auto align Off, segmented sweep Off, fixed center frequency, RBW = 1 MHz, and spans >102 MHz and ≤ 400 MHz.
- Sweeping through 425.6 MHz or 914.6 MHz will cause the measurement speed to degrade.
- Display Off (:DISPlay:ENABLE OFF), and 32-bit integer data format (:FORMat:DATA INT,32), if *Option AYX* or *A4J* is installed, disable sweep ramp, (:SYSTem:PORTs:IFVSweep:ENABLE OFF), markers off, single sweep, measured with IBM compatible PC with 550 MHz Pentium® III running Windows® NT 4.0, one meter GPIB cable, National Instruments PCI-GPIB card and NI-488.2 DLL.
- Factory preset, auto align Off, segmented sweep Off, RBW = 1 MHz, span= 20 MHz, fixed center frequency, average of 100 measurements.
- Factory preset, auto align Off, RBW = 1 MHz, span= 20 MHz, and center frequency tune step size = 50 MHz.

| | Specifications | Supplemental Information |
|--|----------------|--|
| Data Storage Internal External (10 to 40 °C) 3.5" 1.44 MB, MS-DOS® compatible floppy disk | | 200 Traces or States ^a 200 Traces or States ^a |

- When storing traces set to 401 points.

| | Specifications | Supplemental Information |
|--|----------------|---|
| Downloadable Program Memory (Option B72) | | 2 MB available memory 10 MB available memory |

| | Specifications | Supplemental Information |
|---|------------------|---|
| Demod Tune and Listen Demod (Option BAA) | AM Add FM | Internal speaker, front-panel earphone jack and front-panel volume control. |

Agilent E4401B Specifications and Characteristics
General

| | Specifications | Supplemental Information |
|----------------------------|-----------------------|---|
| <i>(Option A4J or AYX)</i> | | An uncalibrated demodulated signal is available on the AUX VIDEO OUT connector at the rear panel. |
| <i>(Option BAA)</i> | | An uncalibrated demodulated signal is available on the EXT VIDEO OUT connector at the rear panel. |

| | Specifications | Supplemental Information |
|---------------------------------|-----------------------|-----------------------------------|
| Weight (without options) | | |
| Net | | 13.2 kg (29.1 lb), characteristic |
| Shipping | | 25.1 kg (55.4 lb), characteristic |

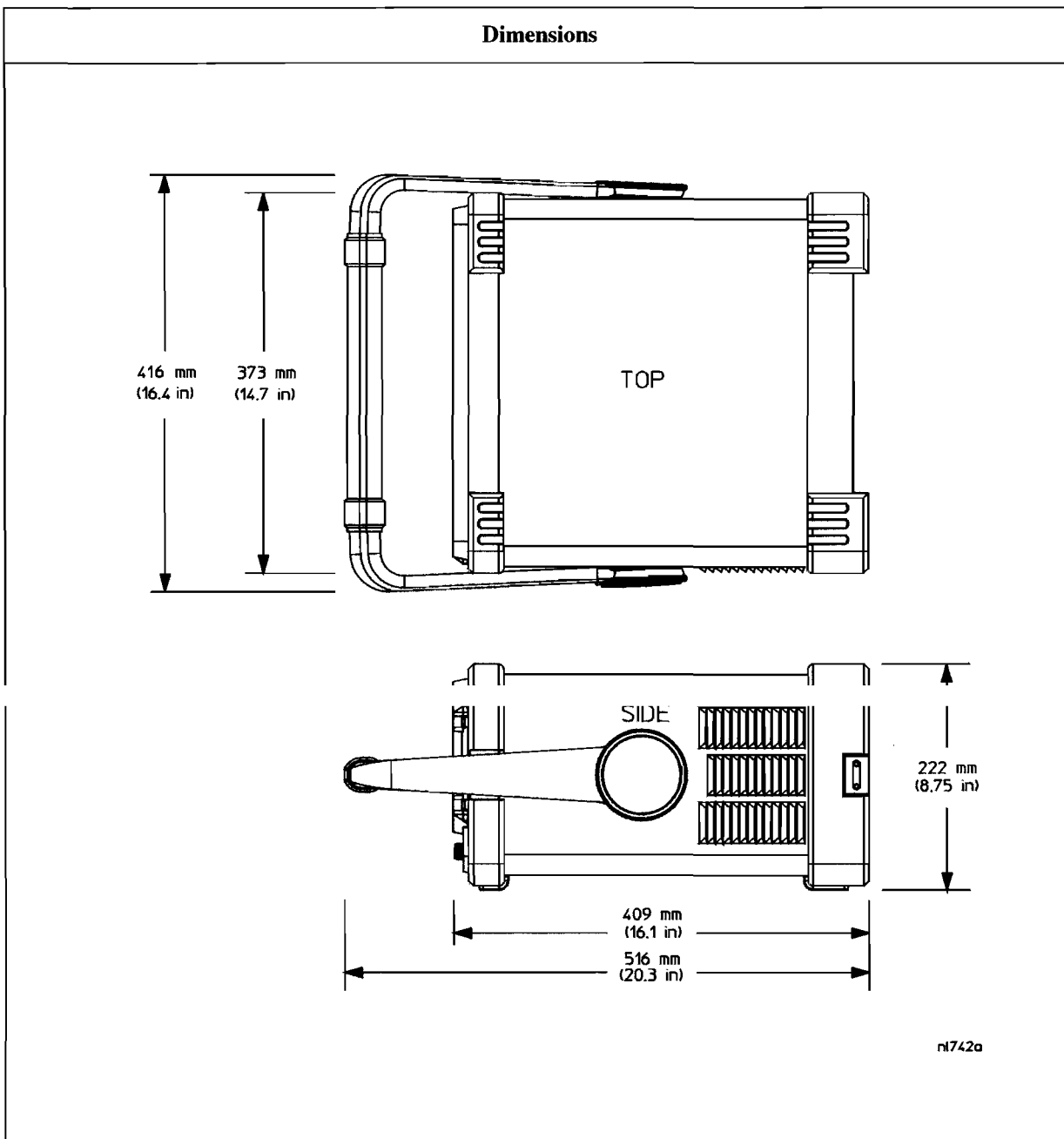

Inputs and Outputs

Internal

| | Specifications | Supplemental Information |
|---|----------------|--|
| Amptd Ref^a | | Amplitude reference |
| Frequency | | 50 MHz |
| Frequency Accuracy | | Frequency reference error ^b |
| 50 Ω Amplitude | | -25 dBm ^c , nominal |
| 75 Ω Amplitude (<i>Option IDP</i>) | | +28.75 dBmV ^c , nominal |

- a. Turn the amplitude reference signal on/off by pressing the keys: **Input/Output, Amptd Ref**.
b. Frequency reference error = (aging rate \times period of time since adjustment + settability + temperature stability).
c. The internal amplitude reference actual power is stored internally.

Front Panel

| | Specifications | Supplemental Information |
|---|----------------|--------------------------|
| INPUT 50 Ω | | |
| Connector | Type-N female | |
| Impedance | | 50 Ω , nominal |
| INPUT 75 Ω (<i>Option IDP</i>) | | |
| Connector | BNC female | |
| Impedance | | 75 Ω , nominal |

| | Specifications | Supplemental Information |
|---|----------------|--------------------------|
| RF OUT 50 Ω, (<i>Option IDN</i>) | | |
| Connector | Type-N female | |
| Impedance | | 50 Ω , nominal |
| RF OUT 75 Ω, (<i>Option IDQ</i>) | | |
| Connector | BNC female | |
| Impedance | | 75 Ω , nominal |

| | Specifications | Supplemental Information |
|---------------------------------------|----------------|--|
| PROBE POWER Voltage/Current | | +15 Vdc, $\pm 7\%$ at 150 mA max., characteristic -12.6 Vdc $\pm 10\%$ at 150 mA max., characteristic |

| | Specifications | Supplemental Information |
|--|------------------------|---|
| EXT KEYBOARD^a Connector | 6-pin mini-DIN | Used for entering screen titles and filenames only. Interface compatible with most IBM-compatible PC keyboards. |

a. The feature is not implemented in firmware revisions prior to A.04.00.

| | Specifications | Supplemental Information |
|----------------|----------------|----------------------------------|
| Speaker | | Front panel knob controls volume |

| | Specifications | Supplemental Information |
|---|--|--|
| Headphone Connector Power Output | 3.5 mm (1/8 inch) miniature audio jack | Front panel knob controls volume 0.2 W into 4 Ω , characteristic |

Rear Panel

| | Specifications | Supplemental Information |
|---|----------------|---|
| 10 MHz REF OUT Connector Impedance Output Amplitude | BNC female | 50 Ω , nominal >0 dBm, characteristic |

Agilent E4401B Specifications and Characteristics
Inputs and Outputs

| | Specifications | Supplemental Information |
|-----------------------|----------------|---|
| 10 MHz REF IN | | |
| Connector | BNC female | Note: Analyzer noise sidebands and spurious response performance may be affected by the quality of the external reference used. |
| Impedance | | 50 Ω , nominal |
| Input Amplitude Range | | -15 to +10 dBm, characteristic |
| Frequency | | 10 MHz, nominal |

| | Specifications | Supplemental Information |
|--|----------------|---|
| GATE TRIG/EXT TRIG IN | | |
| Connector | BNC female | |
| External Trigger Input | | |
| Trigger Level | | Selectable positive or negative edge initiates sweep in EXT TRIG mode (5 V TTL) |
| Gate Trigger Input (<i>Option 1D6</i>) | | |
| Minimum Pulse Width | | >30 ns (5 V TTL) |

| | Specifications | Supplemental Information |
|-----------------------------------|----------------|---|
| GATE/HI SWP OUT | | |
| Connector | BNC female | |
| High Sweep Output | | |
| Level | | High = sweep ^a ; Low = retrace (5 V TTL) |
| Gate Output (<i>Option 1D6</i>) | | |
| Level | | High = gate on; Low = gate off (5 V TTL) |

a. High sweep may be high longer than the indicated sweep times.

| | Specifications | Supplemental Information |
|-------------------|-----------------------------------|--|
| VGA OUTPUT | | |
| Connector | VGA compatible, 15-pin mini D-SUB | VGA (31.5 kHz horizontal, 60 Hz vertical sync rates, non-interlaced) Analog RGB |
| Format | | |
| Resolution | 640 × 480 | |

| | Specifications | Supplemental Information |
|--|-----------------------|---|
| AUX IF OUT <i>(Option A4J or AXX)</i> | | RBW ≥ 1 kHz |
| Connector | BNC female | 21.4 MHz, nominal –10 dBm (uncorrected), characteristic 50 Ω, nominal |
| Frequency | | |
| Amplitude (for signal at reference level and for reference levels – input attenuation + preamp gain of –10 to –70 dBm) | | |
| Impedance | | |

| | Specifications | Supplemental Information |
|--|-----------------------|--|
| AUX VIDEO OUT <i>(Option A4J or AXX)</i> | | RBW ≥ 1 kHz |
| Connector | BNC female | 0 to 1 V (uncorrected), characteristic |
| Amplitude Range (into >10 kΩ) | | |

| | Specifications | Supplemental Information |
|--|-----------------------|--|
| HI SWP IN <i>(Option A4J or AXX)</i> | | |
| Connector | BNC female | Open collector, low resets and holds the sweep (5 V TTL) |
| Input | | |

Agilent E4401B Specifications and Characteristics
Inputs and Outputs

| | Specifications | Supplemental Information |
|--|----------------|---|
| HI SWP OUT <i>(Option A4J or AYX)</i> Connector Output | BNC female | High = sweep ^a , Low = retrace (5 V TTL) |

a. High sweep may be high longer than the indicated sweep times.

| | Specifications | Supplemental Information |
|--|----------------|---------------------------------|
| SWP OUT <i>(Option A4J or AYX)</i> Connector Amplitude | BNC female | 0 to +10 V ramp, characteristic |

| | Specifications | Supplemental Information |
|--|------------------------|--|
| GPIB Interface <i>(Option A4H)</i> Connector GPIB Codes | IEEE-488 bus connector | SH1, AH1, T6, SR1, RL1, PP0, DC1, C1, C2, C3 and C28 |

| | Specifications | Supplemental Information |
|--|------------------|--------------------------|
| Serial Interface <i>(Option 1AX)</i> Connector | 9-pin D-SUB male | RS-232 |

| | Specifications | Supplemental Information |
|--|---------------------|--------------------------|
| Parallel Interface <i>(Option A4H or 1AX)</i> Connector | 25-pin D-SUB female | Printer port only |

| | Specifications | Supplemental Information |
|---|-------------------|--|
| EXT VIDEO IN/TV TRIG OUT^a <i>(Option B7B or BAA)</i> Connector | BNC Female (75 Ω) | EXT VIDEO IN is the Baseband composite video input for TV trigger and picture on screen. TV TRIG OUT is the TV trigger output. |

| | Specifications | Supplemental Information |
|---|-----------------------|---|
| Impedance <i>(Option BAA without Option B7B)</i> External Video Input Video Amplitude TV Trigger Output Amplitude | | 75 Ω , nominal Feature not implemented 1 V _{p-p} , nominal, characteristic Positive edge indicates start of selected TV line after sync. pulse TTL (0 V and 3.4 V with 75 Ω series resistance), characteristic |

- a. This connector is labelled EXT VIDEO IN on older spectrum analyzers and EXT VIDEO IN/TV TRIG OUT on newer spectrum analyzers.

| | Specifications | Supplemental Information |
|--|---------------------------|---|
| EXT VIDEO OUT <i>(Option B7B or BAA)</i> Connector Impedance <i>(Option BAA without Option B7B)</i> Amplitude <i>(Option BAA with Option B7B)</i> Amplitude TV Source: SA TV Source and EXT VIDEO IN | BNC female (75 Ω) | Baseband video output RBW \geq 1 kHz 75 Ω , nominal 0 to 1 V (uncorrected), characteristic 0 to 1 V (uncorrected), characteristic Same as level at EXT VIDEO IN/TV TRIG OUT, characteristic |

Regulatory Information

CAUTION

This product is designed for use in Installation Category II and Pollution Degree 2 per IEC 1010 and 664 respectively.

NOTE

This product has been designed and tested in accordance with IEC Publication 1010, Safety Requirements for Electronic Measuring Apparatus, and has been supplied in a safe condition. The instruction documentation contains information and warnings which must be followed by the user to ensure safe operation and to maintain the product in a safe condition.



The CE mark is a registered trademark of the European Community (if accompanied by a year, it is the year when the design was proven).



The CSA mark is the Canadian Standards Association safety mark.

ISM 1-A

This is a symbol of an Industrial Scientific and Medical Group 1 Class A product. (CISPR 11, Clause 4)

Declaration of Conformity

| DECLARATION OF CONFORMITY | |
|---|---|
| According to ISO/IEC Guide 22 and CEN/CENELEC EN 45014 | |
| Manufacturer's Name: | Agilent Technologies, Inc. |
| Manufacturer's Address: | 1400 Fountaingrove Parkway Santa Rosa, CA 95403-1799 USA |
| Declares that the products | |
| Product Name: | Spectrum Analyzer |
| Model Number: | E4401B, E4402B, E4403B, E4404B, E4405B, E4407B, E4408B, E4411B |
| Product Options: | This declaration covers all options of the above products. |
| Conform to the following product specifications: | |
| EMC: IEC 61326-1:1997+A1:1998 / EN 61326-1:1997+A1:1998 | |
| <u>Standard</u> | <u>Limit</u> |
| CISPR 11:1990 / EN 55011-1991 | Group 1, Class A |
| IEC 61000-4-2:1995+A1998 / EN 61000-4-2:1995 | 4 kV CD, 8 kV AD |
| IEC 61000-4-3:1995 / EN 61000-4-3:1995 | 3 V/m, 80 - 1000 MHz |
| IEC 61000-4-4:1995 / EN 61000-4-4:1995 | 0.5 kV sig., 1 kV power |
| IEC 61000-4-5:1995 / EN 61000-4-5:1996 | 0.5 kV L-L, 1 kV L-G |
| IEC 61000-4-6:1996 / EN 61000-4-6:1998 | 3 V, 0.15 - 80 MHz |
| IEC 61000-4-11:1994 / EN 61000-4-11:1998 | 1 cycle, 100% |
| Safety: IEC 61010-1:1990 + A1:1992 + A2:1995 / EN 61010-1:1993 +A2:1995 CAN/CSA-C22.2 No. 1010.1-92 | |
| Supplementary Information: The products herewith comply with the requirements of the Low Voltage Directive 73/23/EEC and the EMC Directive 89/336/EEC and carry the CE-marking accordingly. | |
|  | |
| Santa Rosa, CA, USA | 17 April 2000 |
| Greg Pfeiffer/Quality Engineering Manager | |
| For further information, please contact your local Agilent Technologies sales office, agent or distributor. | |

**2 Agilent E4402B Specifications and
Characteristics**

About This Chapter

This chapter contains specifications and characteristics for the Agilent E4402B spectrum analyzer. The distinction between specifications and characteristics is described as follows.

- Specifications describe the performance of parameters covered by the product warranty. (The temperature range is 0 °C to 55 °C, unless otherwise noted.)
- Characteristics describe product performance that is useful in the application of the product, but is not covered by the product warranty.
- Typical performance describes additional product performance information that is not covered by the product warranty. It is performance beyond specification that 80% of the units exhibit with a 95% confidence level over the temperature range 20 to 30 °C. Typical performance does not include measurement uncertainty.
- Nominal values indicate the expected performance, or describe product performance that is useful in the application of the product, but is not covered by the product warranty.

The following conditions must be met for the analyzer to meet its specifications.

- o The analyzer is within the one year calibration cycle.
- o If **Auto Align All** is selected:
 - After 2 hours of storage within the operating temperature range.
 - 5 minutes after the analyzer is turned on with sweep times less than 4 seconds.
 - After the front-panel amplitude reference is connected to the INPUT, and **Align Now RF** has been run, after the analyzer is turned on. And, once every 24 hours, or if ambient temperature changes more than 30 °C¹.

1. 10 °C if Preamp (*Option IDS*) is active.

- o If **Auto Align Off** is selected:
 - When the analyzer is at a constant temperature, within the operating temperature range, for a minimum of 90 minutes.
 - After the analyzer is turned on for a minimum of 90 minutes, the front panel amplitude reference has been connected to the INPUT, and **Align Now All** has been run.
 - When **Align Now All** is run:
 - Every hour
 - If the ambient temperature changes more than 3 °C
 - If the 10 MHz reference changes
 - When **Align Now RF** is run (with the front-panel amplitude reference connected to the INPUT):
 - Every 24 hours
 - If the ambient temperature changes more than 30 °C¹
- o If **Auto Align All but RF** is selected:
 - When the analyzer is at a constant temperature, within the operating temperature range, for a minimum of 90 minutes.
 - After the analyzer is turned on for a minimum of 90 minutes, the front panel amplitude reference has been connected to the INPUT, and **Align Now RF** has been run.
 - When **Align Now RF** is run (with the front-panel amplitude reference connected to the INPUT):
 - Every hour
 - If the ambient temperature changes more than 3 °C

1. 10 °C if Preamp (*Option IDS*) is active.

Frequency

| | Specifications | Supplemental Information |
|-------------------------------|--------------------|----------------------------------|
| Frequency Range | 9 kHz to 3.0 GHz | |
| <i>(Option UKB)</i> | | |
| dc Coupled | 100 Hz to 3.0 GHz | 30 Hz to 3.0 GHz, characteristic |
| ac Coupled | 100 kHz to 3.0 GHz | |
| Preamp On <i>(Option IDS)</i> | 1 MHz to 3.0 GHz | |

| | Specifications | Supplemental Information |
|----------------------------|------------------------------|---|
| Frequency Reference | | |
| Aging Rate | $\pm 2 \times 10^{-6}$ /year | $\pm 1.0 \times 10^{-7}$ /day, characteristic |
| Settability | $\pm 5 \times 10^{-7}$ | |
| Temperature Stability | $\pm 5 \times 10^{-6}$ | |

| | Specifications | Supplemental Information |
|---|------------------------------|---|
| High Stability Frequency Reference <i>(Option ID5)</i> | | |
| Aging Rate | $\pm 1 \times 10^{-7}$ /year | $\pm 5 \times 10^{-10}$ /day, 7-day average after being powered on for 7 days, characteristic |
| Settability | $\pm 1 \times 10^{-8}$ | |
| Temperature Stability | | |
| 20 to 30 °C | $\pm 1 \times 10^{-8}$ | |
| 0 to 55 °C | $\pm 5 \times 10^{-8}$ | |
| Warm-up (Internal frequency reference selected) | | |
| After 5 minutes | | $< \pm 1 \times 10^{-7}$ of final frequency, ^a characteristic |
| After 15 minutes | | $< \pm 1 \times 10^{-8}$ of final frequency, ^a characteristic |

a. Final frequency is defined as frequency 60 minutes after power-on with analyzer set to internal frequency reference.

| | Specifications | Supplemental Information |
|--|--|--------------------------|
| Frequency Readout Accuracy (Start, Stop, Center, Marker) | $\pm((\text{frequency indication} \times \text{frequency reference error}^a) + 0.5\% \text{ of span} + \frac{\text{span}}{\text{sweep points} - 1} + 15\% \text{ of RBW} + 10 \text{ Hz})$ | |

a. Frequency reference error = (aging rate × period of time since adjustment + settability + temperature stability).

| | Specifications | Supplemental Information |
|---------------------------------|--|--------------------------|
| Marker Frequency Counter | | |
| Resolution | Selectable from 1 Hz to 100 kHz | |
| Accuracy ^a | $\pm(\text{marker frequency} \times \text{frequency reference error}^b + \text{counter resolution})$ | For RBW ≥ 1 kHz |

a. Marker level to displayed noise level > 25 dB, RBW/ Span ≥ 0.002, frequency offset = 0 Hz.

b. Frequency reference error = (aging rate × period of time since adjustment + settability + temperature stability).

| | Specifications | Supplemental Information |
|-----------------------|---|--------------------------|
| Frequency Span | | |
| Range | 0 Hz (zero span), 100 Hz to 3 GHz | |
| Resolution | 2 Hz | |
| Accuracy ^a | $\pm(0.5\% \text{ of span} + 2 \times \frac{\text{span}}{\text{sweep points} - 1})$ | |

a. Applies to each sweep segment.

| | Specifications | Supplemental Information |
|---------------------------------------|--------------------------------|---|
| Sweep Time | | |
| Range | | |
| Span > 0 Hz | 1 ms to 4000 s ^a | $\frac{\text{sweep points} - 1}{100 \text{ kHz}}$ to 4000 s |
| Span = 0 Hz | 10 μs to 4000 s ^{a,b} | |
| Tracking Generator On (Option 1DN) | | 50 ms is the minimum sweep time |

Agilent E4402B Specifications and Characteristics
Frequency

| | Specifications | Supplemental Information |
|--|--|--|
| Fast Time-domain Sweep (<i>Option AYX</i>) (For Span = 0 Hz, RBW ≥ 1 kHz) | 50 ns to 4000 s ^{c,d} | $\frac{\text{sweep points} - 1}{20 \text{ MHz}}$ to 4000 s |
| DSP and fast ADC (<i>Option B7D</i>) (For Span = 0 Hz, RBW ≥ 1 kHz) | 25 ns to 4000 s ^e | $\frac{\text{sweep points} - 1}{40 \text{ MHz}}$ to 4000 s |
| Accuracy (Span = 0 Hz) | | |
| 10 μs to 4000 s ^{a,b} | ±1% | |
| (<i>Option AYX</i>) | ±1% | |
| 50 ns to 4000 s ^{c,d} | | |
| (<i>Option B7D</i>) | ±1% | |
| 25 ns to 4000 s ^e | | |
| Sweep Trigger ^{f,g} | Free Run, Single, Line, Video ^h , External, Delayed, Offset ⁱ | |
| (<i>Option 1D6</i>) | Add Gate | |
| (<i>Option B7B</i>) | Add TV | |
| (<i>Option B7E</i>) | Add Burst Carrier Trigger | |
| Delayed Trigger ^{g,j} | | |
| Range | 1 μs to 400 s | |
| Resolution | $\frac{\text{delay in seconds}}{65000}$ rounded up to nearest μs | |
| Accuracy | ±(500 ns + (0.01% of delay)) | |
| Offset Trigger ⁱ | | |
| Resolution | $\frac{\text{sweep time}}{\text{sweep points} - 1}$ | |
| Range | ±327 ms to ±12.3 ks | Where ST = sweep time and SP = sweep points $\frac{-32766 \times ST}{SP - 1}$ to $\frac{(32766 - SP) \times ST}{SP - 1}$ |

| | Specifications | Supplemental Information |
|--|---------------------|--|
| Fast Time-domain sweep <i>(Option AYX)</i> (For sweep times $\frac{\text{sweep points} - 1}{20 \text{ MHz}}$ to $\frac{\text{sweep points} - 1}{100 \text{ kHz}}$) | ±1.23 ms to ±245 ms | $\frac{-32766 \times ST}{SP - 1}$ to $\frac{(32766 - SP) \times ST}{SP - 1}$ |
| DSP and fast ADC <i>(Option B7D)</i> (For sweep times $\frac{\text{sweep points} - 1}{40 \text{ MHz}}$ to $\frac{\text{sweep points} - 1}{100 \text{ kHz}}$) | ± 13 ms to ±5.15 s | $\frac{-524031 \times ST}{SP - 1}$ to $\frac{(524031 - SP) \times ST}{SP - 1}$ |

- a. For firmware revisions prior to A.04.00, 5 ms to 2000 s.
- b. For firmware revisions prior to A.05.00, 1 ms to 4000 s.
- c. For firmware revisions prior to A.04.00, 20 μs to 2000 s.
- d. For firmware revisions prior to A.05.00, 5 μs to 4000 s.
- e. For firmware revisions prior to A.05.00, 2.5 μs to 4000 s.
- f. Gate cannot be used simultaneously with delayed or TV trigger (*Option B7B*).
- g. Auto align is suspended in video, external, gate, and delayed trigger modes while waiting for a trigger event to occur.
- h. Unavailable when RBW ≤ 300 Hz (*Option 1DR*).
- i. For firmware revision A.04.00 or later.
- j. Delayed trigger is available with line, external trigger, and TV trigger (*Option B7B*).

| | Specifications | Supplemental Information |
|--|--|--------------------------|
| Sweep (trace) Points Range Span > 0 Hz Span = 0 Hz | 101 to 8192 ^a 2 to 8192 ^{a,b} | |

- a. For firmware revisions prior to A.04.00, 401 points.
- b. For firmware revisions prior to A.05.00, 101 to 8192 points.

Agilent E4402B Specifications and Characteristics
Frequency

| | Specifications | Supplemental Information |
|--|---|--|
| Resolution Bandwidth (RBW) | | |
| Range | | |
| –3 dB bandwidth | 1 kHz to 3 MHz, in 1-3-10 sequence, 5 MHz | |
| –6 dB bandwidth (EMI) | 9 kHz and 120 kHz | |
| (Option 1DR) | | Only available in spans ≤ 5 MHz, sweep times $\geq \frac{\text{sweep points} - 1}{100 \text{ kHz}}$, and not usable with tracking generator on. (Option 1DN) |
| –3 dB bandwidth | Adds 10, 30, 100, 300 Hz | |
| –6 dB bandwidth (EMI) | Add 200 Hz | |
| Accuracy | | |
| 1 kHz to 3 MHz RBW | $\pm 15\%$ | |
| 5 MHz RBW | $\pm 30\%$ | |
| Shape | | |
| 1 kHz to 5 MHz RBW | | Synchronously tuned four poles, approximately Gaussian shape |
| 10 Hz to 300 Hz RBW (Option 1DR) | | Digital, approximately Gaussian shape |
| Selectivity (60 dB/3 dB bandwidth ratio) | | |
| 1 kHz to 5 MHz RBW | | $<15:1$, characteristic |
| 10 Hz to 300 Hz RBW (Option 1DR) | | $<5:1$, characteristic |

| | Specifications | Supplemental Information |
|--------------------------------------|-------------------------------------|--|
| Video Bandwidth (VBW) (–3 dB) | | |
| Range | | |
| 30 Hz to 1 MHz in 1-3-10 sequence | | 3 MHz, characteristic |
| (Option 1DR) | Adds 1, 3, 10 Hz for RBW's <1 kHz | |
| Accuracy | | $\pm 30\%$, characteristic |
| Shape | | Post detection, single pole low-pass filter used to average displayed noise Video bandwidths below 30 Hz are digital bandwidths with anti-aliasing filtering. |

| | Specifications | Supplemental Information |
|--|-----------------------------|---|
| Stability | | |
| Noise Sidebands (Offset from CW signal with 1 kHz RBW, 30 Hz VBW and sample detector) | | |
| ≥ 1 kHz (<i>Option 1DR, 1D5</i>) | | ≤ -78 dBc/Hz, typical |
| ≥ 10 kHz | ≤ -90 dBc/Hz | ≤ -94 dBc/Hz, typical |
| ≥ 20 kHz | ≤ -100 dBc/Hz | ≤ -105 dBc/Hz, typical |
| ≥ 30 kHz | ≤ -106 dBc/Hz | ≤ -112 dBc/Hz, typical |
| ≥ 100 kHz | ≤ -119 dBc/Hz | ≤ -122 dBc/Hz, typical |
| ≥ 1 MHz | ≤ -125 dBc/Hz | ≤ -127 dBc/Hz, typical |
| ≥ 5 MHz | ≤ -127 dBc/Hz | ≤ -129 dBc/Hz, typical |
| ≥ 10 MHz | ≤ -131 dBc/Hz | ≤ -136 dBc/Hz, typical |
| <i>(Option 120)</i> | | |
| ≥ 1 MHz | ≤ -133 dBc/Hz | ≤ -136 dBc/Hz, typical |
| ≥ 5 MHz | ≤ -135 dBc/Hz | ≤ -139 dBc/Hz, typical |
| ≥ 10 MHz | ≤ -137 dBc/Hz | ≤ -141 dBc/Hz, typical |
| Residual FM | | |
| 1 kHz RBW, 1 kHz VBW | ≤ 150 Hz p-p in 100 ms | |
| <i>(Option 1D5)</i> | ≤ 100 Hz p-p in 100 ms | |
| 10 Hz RBW, 10 Hz VBW | ≤ 2 Hz p-p in 20 ms | |
| <i>(Option 1DR and 1D5)</i> | | |
| 10 Hz RBW, 10 Hz VBW | | ≤ 10 Hz p-p in 20 ms, characteristic |
| <i>(Option 1DR)</i> | | |

| | Specifications | Supplemental Information |
|---|----------------|--|
| System-Related Sidebands, offset from CW signal ≥30 kHz | ≤ -65 dBc | |
| Line-Related Sidebands, offset from CW signal (<i>Option 1DR</i>) <300 Hz >300 Hz to 30 kHz | | ≤ -50 dBc, characteristic ≤ -55 dBc, characteristic |

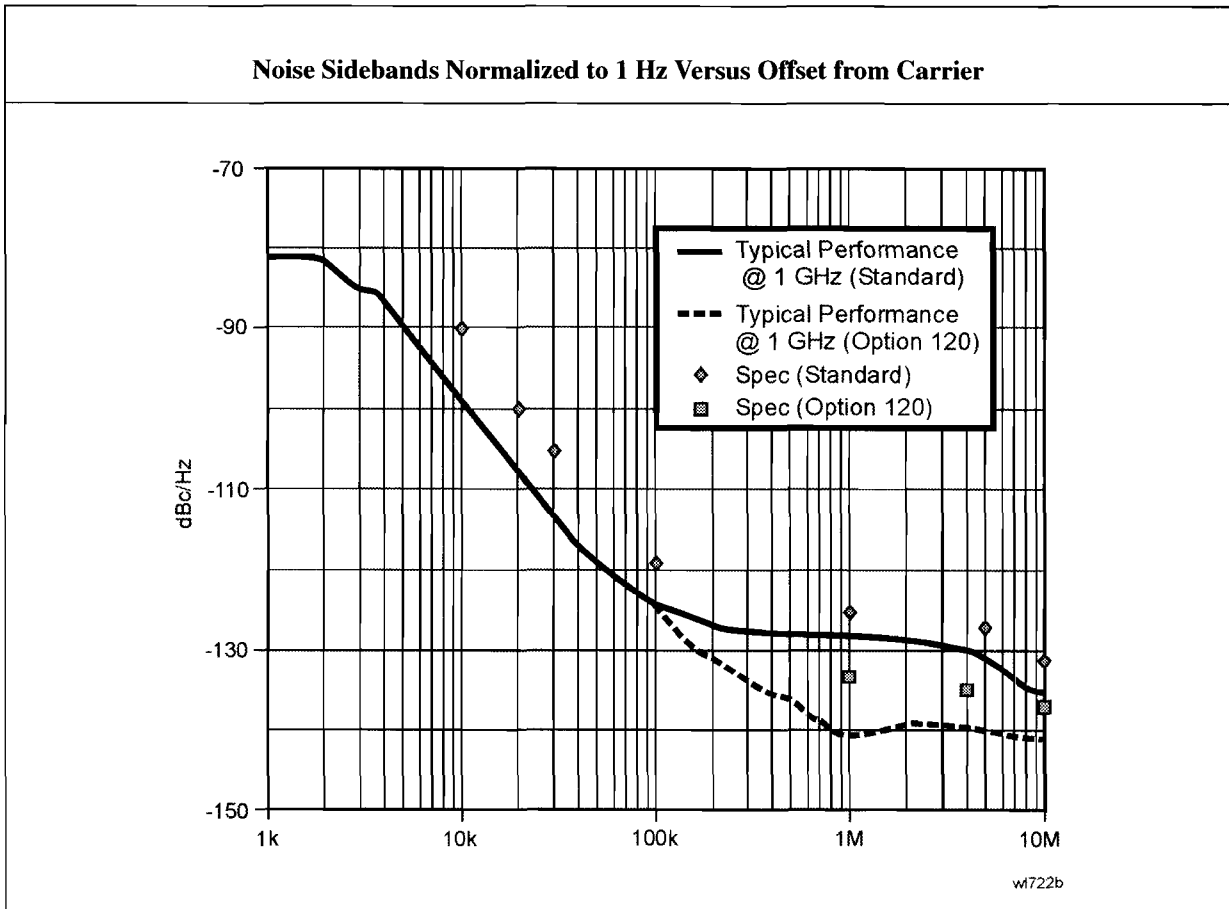

Amplitude

Amplitude specifications do not apply for the negative peak detector mode.

| | Specifications | Supplemental Information |
|--------------------------|---|---|
| Measurement Range | Displayed Average Noise Level to Maximum Safe Input Level | |
| Input Attenuator Range | 0 to 65 dB, in 5 dB steps | 0 to 75 dB, in 5 dB steps, characteristic |

| | Specifications | Supplemental Information |
|--|-----------------|--------------------------|
| Maximum Safe Input Level | | |
| Average Continuous Power (Input attenuator setting ≥ 5 dB) | +30 dBm (1 W) | |
| Peak Pulse Power (for $< 10 \mu\text{sec}$ pulse width, $< 1\%$ duty cycle, and input attenuation ≥ 30 dB) | +50 dBm (100 W) | |
| dc (Option UKB) | 100 Vdc | |
| dc coupled | 0 Vdc | |
| ac coupled | 50 Vdc | |

| | Specifications | Supplemental Information |
|--|----------------|--------------------------|
| 1 dB Gain Compression | | |
| Total power at input mixer ^{a,b} 50 MHz to 3.0 GHz Preamp On (Option IDS) | 0 dBm | |
| Total power at the preamp ^c | | -20 dBm, characteristic |

a. Mixer power level (dBm) = input power (dBm) – input attenuation (dB).

b. For resolution bandwidths 1 kHz to 30 kHz, the maximum input signal amplitude must be \leq reference level +10 dB.

c. Total power at the preamp (dBm) = total power at the input (dBm) – input attenuation (dB).

Agilent E4402B Specifications and Characteristics
Amplitude

| | Specifications | | Supplemental Information | |
|--|------------------------|--|-------------------------------------|---|
| | | | | |
| Displayed Average Noise Level (Input terminated, 0 dB attenuation, sample detector, Reference Level = -70 dBm) | | | | |
| | 1 kHz RBW 30 Hz VBW | 10 Hz RBW 1 Hz VBW (<i>Option 1DR</i>) | 1 kHz RBW 30 Hz VBW (typical) | 10 Hz RBW 1 Hz VBW (<i>Option 1DR</i>) (typical) |
| 30 Hz to 9 kHz (<i>Option UKB</i>) | | | | ≤ -93 dBm |
| 9 kHz to 100 kHz | | | | ≤ -109 dBm |
| 100 kHz to 1 MHz | | | | ≤ -135 dBm |
| 1 MHz to 10 MHz | | | ≤ -117 dBm | ≤ -136 dBm |
| 1 MHz to 10 MHz (<i>Option 120</i>) | | | ≤ -120 dBm | ≤ -139 dBm |
| 10 MHz to 1.0 GHz | ≤ -117 dBm | ≤ -136 dBm | ≤ -120 dBm | ≤ -140 dBm |
| 1.0 GHz to 2.0 GHz | ≤ -116 dBm | ≤ -135 dBm | ≤ -120 dBm | ≤ -140 dBm |
| 2.0 GHz to 3.0 GHz | ≤ -114 dBm | ≤ -133 dBm | ≤ -120 dBm | ≤ -140 dBm |
| Preamp On (<i>Option 1DS</i>) | 1 kHz RBW 30 Hz VBW | 10 Hz RBW 1 Hz VBW (<i>Option 1DR</i>) | 1 kHz RBW 30 Hz VBW (typical) | 10 Hz RBW 1 Hz VBW (<i>Option 1DR</i>) (typical) |
| 0 to 55 °C | | | | |
| 10 MHz to 1.0 GHz | ≤ -132 dBm | ≤ -151 dBm | | |
| 1.0 GHz to 2.0 GHz | ≤ -132 dBm | ≤ -151 dBm | | |
| 2.0 GHz to 3.0 GHz | ≤ -129 dBm | ≤ -148 dBm | | |
| 20 to 30 °C | | | | |
| 1 MHz to 10 MHz | | | ≤ -134 dBm | ≤ -152 dBm |
| 10 MHz to 1.0 GHz | ≤ -133 dBm | ≤ -152 dBm | ≤ -136 dBm | ≤ -156 dBm |
| 1.0 GHz to 2.0 GHz | ≤ -134 dBm | ≤ -153 dBm | ≤ -136 dBm | ≤ -156 dBm |
| 2.0 GHz to 3.0 GHz | ≤ -132 dBm | ≤ -151 dBm | ≤ -134 dBm | ≤ -154 dBm |

| | Specifications | Supplemental Information |
|---|---|--------------------------|
| Display Range | | |
| Log Scale | Ten divisions displayed; 0.1, 0.2, 0.5 dB/division and 1 to 20 dB/division in 1 dB steps | |
| RBW \geq 1 kHz | Calibrated 0 to -85 dB from Reference Level | |
| RBW \leq 300 Hz (<i>Option IDR</i>) | Calibrated 0 to -120 dB ^a from Reference Level | |
| Linear Scale | Ten divisions | |
| Scale Units | dBm, dBmV, dB μ V, dB μ A, A, V, and W | |
| (<i>Option BAA, 106</i>) | Add Hz | |

- a. 0 to -70 dB range when span = 0 Hz, or when IF Gain fixed:
(:DISPlay:WINDow:TRACe:Y[:SCALe]:LOG:RANGe:AUTO OFF).

| | Specifications | Supplemental Information |
|---|--|--------------------------|
| Marker Readout Resolution | | |
| Log scale | | |
| RBW \geq 1 kHz | | |
| 0 to -85 dB from ref level | 0.04 dB | |
| RBW \leq 300 Hz (<i>Option IDR</i>) | | |
| 0 to -120 dB from ref level | 0.04 dB | |
| Linear scale | 0.01% of Reference Level | |
| Fast Sweep Times for Zero Span | | |
| (<i>Option AYX</i>) | | |
| For sweep times | | |
| $\frac{\text{sweep points} - 1}{20 \text{ MHz}}$ to | | |
| $\frac{\text{sweep points} - 1}{100 \text{ kHz}}$ | | |
| Log | | |
| 0 to -85 dB from ref level | 0.3 dB | |
| Linear | 0.3% of Reference Level for linear scale | |

Agilent E4402B Specifications and Characteristics
Amplitude

| | Specifications | Supplemental Information |
|--|---|--------------------------|
| <p><i>(Option B7D)</i> For sweep times $\frac{\text{sweep points} - 1}{40 \text{ MHz}}$ to $\frac{\text{sweep points} - 1}{100 \text{ kHz}}$</p> <p>Log 0 to -85 dB from ref level</p> <p>Linear</p> | <p>0.2 dB</p> <p>0.2% of Reference Level for linear scale</p> | |

| | Specifications | Supplemental Information |
|--|---|--|
| <p>Frequency Response^a</p> <p>10 dB attenuation</p> <p>9 kHz to 3.0 GHz</p> <p>20 to 30 °C</p> <p>0 to 55 °C</p> <p>800 MHz to 1.0 GHz^b</p> <p>20 to 30 °C</p> <p>0 to 55 °C</p> <p>1.7 GHz to 2.0 GHz^b</p> <p>20 to 30 °C</p> <p>0 to 55 °C</p> <p><i>(Option UKB)</i></p> <p>100 Hz to 3.0 GHz (dc coupled)</p> <p>20 to 30 °C</p> <p>0 to 55 °C</p> <p>30 Hz to 3.0 GHz (dc coupled)</p> <p>20 to 30 °C</p> <p>0 to 55 °C</p> | <p>±0.46 dB</p> <p>±0.76 dB</p> <p>±0.46 dB</p> <p>±0.76 dB</p> <p>±0.46 dB</p> <p>±0.76 dB</p> <p>±0.5 dB</p> <p>±1.0 dB</p> | <p>±0.12 dB, typical</p> <p>±0.04 dB, typical</p> <p>±0.04 dB, typical</p> <p>±0.5 dB, characteristic</p> <p>±1.0 dB, characteristic</p> |

| | Specifications | Supplemental Information |
|------------------------------------|----------------|--------------------------|
| 100 kHz to 3.0 GHz (ac coupled) | | |
| 20 to 30 °C | ±0.5 dB | |
| 0 to 55 °C | ±1.0 dB | |
| 800 MHz to 1.0 GHz (ac coupled) | | |
| 20 to 30 °C | ±0.5 dB | |
| 0 to 55 °C | ±1.0 dB | |
| 1.7 GHz to 2.0 GHz (ac coupled) | | |
| 20 to 30 °C | ±0.5 dB | |
| 0 to 55 °C | ±1.0 dB | |
| Preamp On (<i>Option 1DS</i>) | | |
| 0 dB attenuation | | |
| 1 MHz to 3.0 GHz | | |
| 20 to 30 °C | ±1.5 dB | |
| 0 to 55 °C | ±2.0 dB | |
| 800 MHz to 1.0 GHz | | |
| 20 to 30 °C | ±1.5 dB | ±0.22 dB, typical |
| 0 to 55 °C | ±2.0 dB | |
| 1.7 GHz to 2.0 GHz | | |
| 20 to 30 °C | ±1.5 dB | ±0.16 dB, typical |
| 0 to 55 °C | ±2.0 dB | |

- a. Frequency response values are referenced to the amplitude at 50 MHz.
b. This specification applies only to analyzers with serial numbers \geq US39441006.

Agilent E4402B Specifications and Characteristics
Amplitude

| | Specifications | Supplemental Information |
|--|---------------------------------------|--------------------------|
| Input Attenuation Switching Uncertainty at 50 MHz | | |
| Attenuator Setting | | |
| 0 dB to 5 dB | ±0.3 dB | |
| 10 dB | Reference | |
| 15 dB | ±0.3 dB | |
| 20 to 65 dB attenuation | ±(0.1 dB + 0.01 × Attenuator Setting) | |

| Attenuation Accuracy Relative to the 10 dB Attenuator Setting, Characteristic | | |
|--|-------------------|--|
| | Frequency Range | |
| Attenuation | dc–3.0 GHz | |
| 0 dB | ±0.3 dB | |
| 5 dB | ±0.3 dB | |
| 10 dB | Reference | |
| 15 dB | ±0.4 dB | |
| 20 dB | ±0.4 dB | |
| 25 dB | ±0.5 dB | |
| 30 dB | ±0.5 dB | |
| 35 dB | ±0.6 dB | |
| 40 dB | ±0.6 dB | |
| 45 dB | ±0.7 dB | |
| 50 dB | ±0.7 dB | |
| 55 dB | ±0.9 dB | |
| 60 dB | ±0.9 dB | |
| 65 dB | ±1.0 dB | |

| | Specifications | Supplemental Information |
|----------------------------|----------------|---|
| Preamp (Option IDS) | | Refer also to Displayed Average Noise Level specification |
| Gain | | +20 dB, nominal ^a |
| Noise figure | | 5 dB, characteristic |

a. Amplifier is between the input attenuator and the input mixer.

| | Specifications | Supplemental Information |
|---|---|--------------------------|
| Absolute Amplitude Accuracy | | |
| At reference settings ^a | ±0.34 dB | ±0.13 dB, typical |
| Preamp On ^b (Option IDS) | ±0.37 dB | ±0.14 dB, typical |
| Overall Amplitude Accuracy^c | | |
| 20 to 30 °C | ± (0.54 dB + Absolute Frequency Response) | |

- a. Settings are: reference level -20 dBm; input attenuation 10 dB; dc coupled (Option UKB); center frequency 50 MHz; RBW 1 kHz; VBW 1 kHz; scale linear or log; span 2 kHz; sweep time coupled, sample detector, signal at reference level.
- b. Settings are: reference level -30 dBm; input attenuation 0 dB; dc coupled (Option UKB); center frequency 50 MHz; RBW 1 kHz; VBW 1 kHz; scale linear or log; span 2 kHz; sweep time coupled, signal at reference level.
- c. For reference level 0 to -50 dBm; input attenuation 10 dB; dc coupled (Option UKB); RBW 1 kHz; VBW 1 kHz; scale log, log range 0 to -50 dB from reference level; sweep time coupled; signal input 0 to -50 dBm; span ≤20 kHz.

| | Specifications | Supplemental Information |
|---|----------------|--------------------------|
| RF Input VSWR (at tuned frequency) | | |
| Attenuator setting 0 dB | | characteristic |
| 100 kHz to 3 GHz | | ≤3.0:1 |
| Attenuator setting 5 dB | | |
| 100 kHz to 3 GHz | | ≤1.6:1 |
| Attenuator setting 10 to 65 dB | | |
| 9 kHz to 100 kHz | | ≤2.0:1 |
| 100 kHz to 3 GHz | | ≤1.4:1 |

Agilent E4402B Specifications and Characteristics
Amplitude

| | Specifications | Supplemental Information | |
|--------------------------------|----------------|--------------------------|----------------|
| <i>(Option UKB)</i> | | characteristic | characteristic |
| Attenuator setting 0 dB | | (dc coupled) | (ac coupled) |
| 100 Hz to 100 kHz | | ≤1.1:1 | |
| 100 kHz to 3 GHz | | ≤3.0:1 | ≤3.0:1 |
| Attenuator setting 5 dB | | (dc coupled) | (ac coupled) |
| 100 Hz to 100 kHz | | ≤1.1:1 | |
| 100 kHz to 300 kHz | | ≤1.1:1 | ≤2.3:1 |
| 300 kHz to 1.0 MHz | | ≤1.1:1 | ≤1.6:1 |
| 1.0 MHz to 3.0 GHz | | ≤1.4:1 | ≤1.4:1 |
| Attenuator setting 10 to 65 dB | | (dc coupled) | (ac coupled) |
| 100 Hz to 100 kHz | | ≤1.1:1 | |
| 100 kHz to 300 kHz | | ≤1.1:1 | ≤2.1:1 |
| 300 kHz to 1.0 MHz | | ≤1.1:1 | ≤1.5:1 |
| 1.0 MHz to 3.0 GHz | | ≤1.2:1 | ≤1.2:1 |

| | Specifications | Supplemental Information |
|-----------------------------------|----------------|--------------------------|
| Auto Alignment^a | | |
| Sweep-to-sweep variation | | ±0.1 dB, characteristic |

a. Set **Auto Align** to **Off** and use **Align Now, All** to eliminate this variation.

| | Specifications | Supplemental Information |
|--|----------------|--------------------------|
| Resolution Bandwidth Switching Uncertainty (at Reference Level) | | |
| 1 kHz RBW | Reference | |
| 3 kHz to 3 MHz RBW | ±0.3 dB | |
| 5 MHz RBW | ±0.6 dB | |
| 10 Hz to 300 Hz RBW <i>(Option IDR)</i> | ±0.3 dB | |

| | Specifications | Supplemental Information |
|--|--|--------------------------|
| Reference Level | | |
| Range | -149.9 dBm to maximum mixer level + attenuator setting | |
| Resolution | | |
| Log Scale | ±0.1 dB | |
| Linear Scale | ±0.12% of Reference Level | |
| Accuracy (at a fixed frequency, a fixed attenuator, and referenced to -30 dBm (-10 dBm, Preamp On (Option 1DS))) | | |
| Reference Level (dBm) – input attenuator setting (dB) + preamp gain (dB) | | |
| -10 dBm to > -60 dBm | ±0.3 dB | |
| -60 dBm to > -85 dBm | ±0.5 dB | |
| -85 dBm to -90 dBm | ±0.7 dB | |

| | Specifications | Supplemental Information |
|--|-----------------------------|--------------------------|
| Display Scale Switching Uncertainty | | |
| Switching between Linear and Log | ±0.15 dB at reference level | |
| Log Scale Switching | No error | |

| | Specifications | Supplemental Information |
|-------------------------------|----------------|--------------------------|
| Display Scale Fidelity | | |
| Log Maximum Cumulative | | |
| RBW ≥ 1 kHz | | |
| dB Below Reference Level | | |
| 0 dB Reference | 0 dB | |
| > 0 to 10 dB | ±0.22 dB | ±0.08 dB, typical |
| > 10 to 20 dB | ±0.24 dB | ±0.09 dB, typical |
| > 20 to 30 dB | ±0.26 dB | ±0.10 dB, typical |
| > 30 to 40 dB | ±0.40 dB | ±0.23 dB, typical |

Agilent E4402B Specifications and Characteristics
Amplitude

| | Specifications | Supplemental Information |
|---|---|--------------------------|
| > 40 to 50 dB | ±0.57 dB | ±0.35 dB, typical |
| > 50 to 60 dB | ±0.57 dB | ±0.35 dB, typical |
| > 60 to 70 dB | ±0.66 dB | ±0.39 dB, typical |
| >70 to 80 dB | ±0.66 dB | ±0.46 dB, typical |
| >80 to 85 dB | ±1.15 dB | ±0.79 dB, typical |
| RBW ≤ 300 Hz (<i>Option 1DR</i>) | | |
| Span > 0 Hz | | |
| Auto range On | | |
| 0 to 98 dB below reference level | ±(0.3 dB + 0.01 × dB from reference level) | |
| > 98 to 120 dB below reference level | | ±2.0 dB, characteristic |
| Auto range Off | | |
| 0 to 60 dB below reference level | ±(0.3 dB + 0.015 × dB from reference level) | |
| > 60 to 70 dB below reference level | ±1.5 dB | |
| Span = 0 Hz ^a | | |
| 0 to 60 dB below reference level | ±(0.3 dB + 0.015 × dB from reference level) | |
| > 60 to 70 dB below reference level | ±1.5 dB | |
| Log Incremental Accuracy | | |
| 0 to 80 dB ^b below reference level | ±0.4 dB/4 dB | |
| Linear Accuracy | | |
| | ±2% of Reference Level | |

- a. The SCPI command for auto range off is:
(:DISPlay:WINDow:TRACe:Y[:SCALE]:LOG:RANGe:AUTO OFF)
- b. 0 to -50 dB for RBWs ≤ 300 Hz and span = 0 Hz, or when auto ranging is off.

| | Specifications | Supplemental Information |
|--|--|--|
| Spurious Responses | | |
| Second Harmonic Distortion | | |
| Input Signal | | |
| 10 MHz to 500 MHz | < -65 dBc for -30 dBm signal at input mixer ^a | +35 dBm SHI (second harmonic intercept) |
| 500 MHz to 1.5 GHz | < -75 dBc for -30 dBm signal at input mixer ^a | +45 dBm SHI |
| Preamp On (<i>Option IDS</i>) 10 MHz to 1.5 GHz | | -5 dBm SHI, characteristic |
| Third Order Intermodulation Distortion | | |
| 10 MHz to 100 MHz | | +7 dBm TOI (third order intercept), characteristic |
| 100 MHz to 3 GHz | < -85 dBc for two -30 dBm signals at input mixer ^a and >50 kHz separation | +12.5 dBm TOI +16 dBm TOI, typical |
| Preamp On (<i>Option IDS</i>) 10 MHz to 3 GHz | | -16 dBm TOI, characteristic |
| Other Input Related Spurious | | |
| >30 kHz offset | < -65 dBc for -20 dBm signal at input mixer ^a | |

a. Mixer power level (dBm) = input power (dBm) – input attenuation (dB).

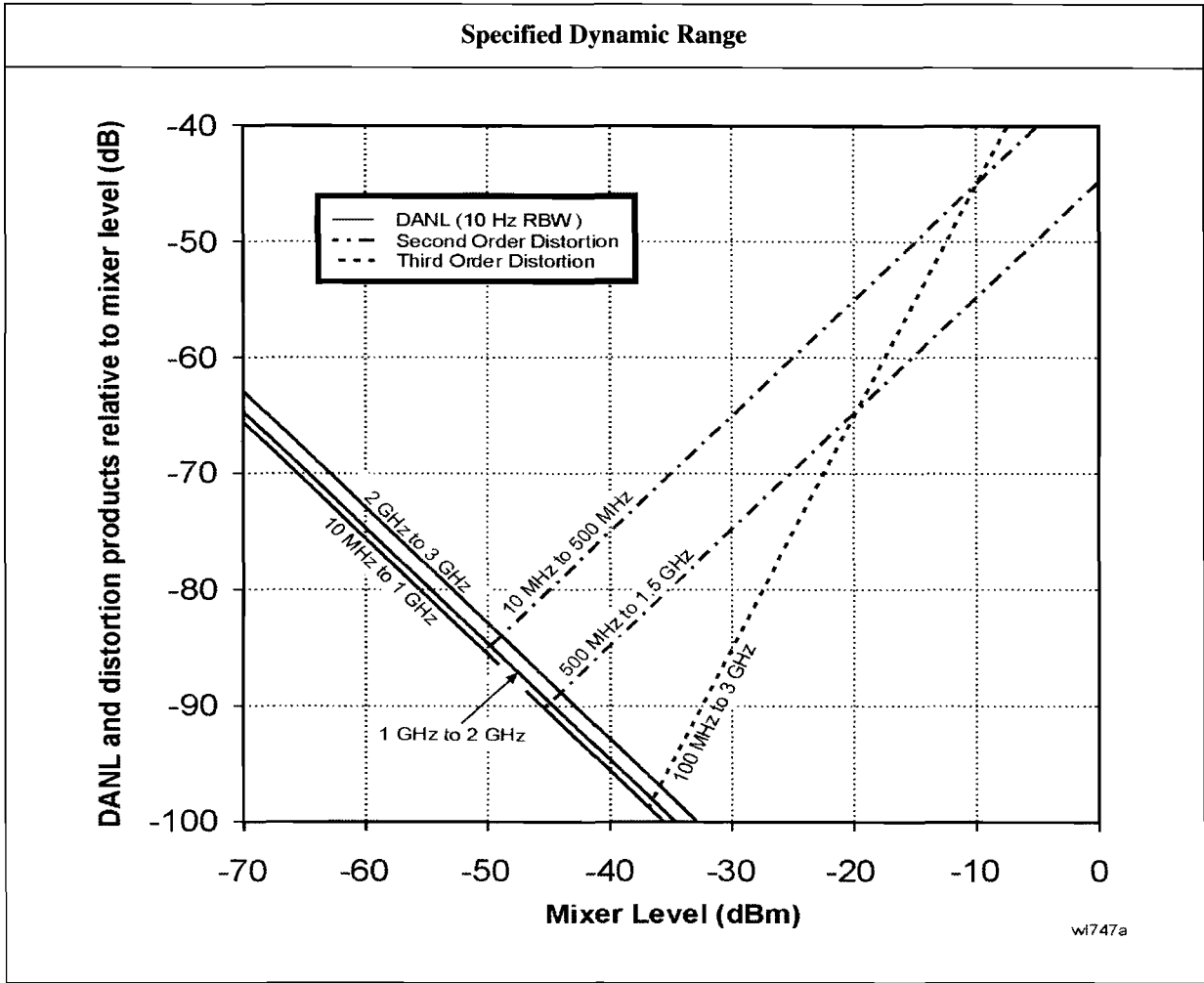

| | Specifications | Supplemental Information |
|---|----------------|--------------------------|
| Residual Responses (Input terminated and 0 dB attenuation) 150 kHz to 3 GHz | < -90 dBm | |

Options

Time Gated Spectrum Analysis (Option 1D6)

| | Specifications | Supplemental Information |
|---|---|---|
| Gate Delay | | |
| Range | 1 μ s to 400 s | |
| Accuracy | $\pm(500 \text{ ns} + (0.01\% \times (\text{maximum of gate delay or length})))$ | From gate trigger input to positive edge of gate output |
| Gate Length | | |
| Range | 1 μ s to 400 s | |
| Accuracy | $\pm(500 \text{ ns} + (0.01\% \times (\text{maximum of gate delay or length})))$ | From positive edge to negative edge of gate output |
| Resolution | $((\text{maximum of gate delay or length in seconds})/65000)$ rounded up to nearest μ s | Dependent on the greater of gate delay or gate length |
| Additional Amplitude Error^a | | |
| Log Scale | $\pm 0.2 \text{ dB}$ | |
| Linear Scale | $\pm 0.1\%$ of reference level | |

a. While in gate mode.

Tracking Generator (Option 1DN)

The spectrum analyzer/tracking generator combination will meet its specification after a cable (8120-5148) and adapter are connected between RF OUT and INPUT and **Align Now, TG** has been run.

| | Specifications | Supplemental Information |
|----------------|----------------|--------------------------|
| Warm-up | 5 minutes | |

| | Specifications | Supplemental Information |
|-------------------------------|------------------|--------------------------|
| Output Frequency Range | 9 kHz to 3.0 GHz | |

| | Specifications | Supplemental Information |
|------------------------------|----------------|--|
| Minimum Resolution BW | 1 kHz | Not usable with resolution bandwidths ≤ 300 Hz (<i>Option IDR</i>) |

| | Specifications | Supplemental Information |
|---|--------------------------|--------------------------|
| Output Power Level | | |
| Range | -2 to -66 dBm | |
| Resolution | 0.1 dB | |
| Absolute Accuracy (at 50 MHz with coupled source attenuator, referenced to -20 dBm) | ± 0.75 dB | |
| Vernier | | |
| Range | 8 dB | |
| Accuracy (with coupled source attenuator, 50 MHz, -20 dBm) | | |
| Incremental | ± 0.2 dB/dB | |
| Cumulative | ± 0.5 dB, total | |
| Output Attenuator Range | 0 to 56 dB in 8 dB steps | |

| | Specifications | Supplemental Information |
|-----------------------------------|----------------|---------------------------------------|
| Maximum Safe Reverse Level | | +30 dBm (1 W), 50 Vdc, characteristic |

| | Specifications | Supplemental Information |
|---------------------------|---|--------------------------|
| Output Power Sweep | | |
| Range | (-10 to -2 dBm) – (Source Attenuator Setting) | |
| Resolution | 0.1 dB | |
| Accuracy (zero span) | <1 dB peak-to-peak | |

| | Specifications | Supplemental Information |
|-------------------------------|----------------|--------------------------|
| Output Flatness | | |
| Referenced to 50 MHz, -20 dBm | | |
| 9 kHz to 10 MHz | ±3 dB | |
| 10 MHz to 3 GHz | ±2 dB | |

| | Specifications | Supplemental Information |
|---|----------------|--------------------------|
| Spurious Outputs | | |
| (-2 dBm output) | | |
| Harmonic Spurs | | |
| TG Output 9 kHz to 20 kHz | ≤ -15 dBc | |
| TG Output 20 kHz to 3 GHz | ≤ -25 dBc | |
| Non-harmonic Spurs | | |
| TG Output 9 kHz to 2 GHz | ≤ -27 dBc | |
| TG Output 2 GHz to 3 GHz | ≤ -23 dBc | |
| LO Feedthrough | | |
| LO Frequency 3.921409 GHz to 6.9214 GHz | ≤ -16 dBm | |

| | Specifications | Supplemental Information |
|----------------------|---|--------------------------|
| Dynamic Range | Maximum Output Power Level – Displayed Average Noise Level | |

Agilent E4402B Specifications and Characteristics
Options

| | Specifications | Supplemental Information |
|---|----------------|--|
| Output Tracking Drift Swept Tracking Error | | 1.5 kHz/5 minute, characteristic Usable in 1 kHz RBW after 5 minutes of warm-up |

| | Specifications | Supplemental Information |
|---|----------------|----------------------------|
| RF Power-Off Residuals 9 kHz to 3 GHz | | < -120 dBm, characteristic |

| | Specifications | Supplemental Information |
|--|----------------|---|
| Output Attenuator Repeatability 9 kHz to 300 MHz 300 MHz to 2 GHz 2 GHz to 3 GHz | | ±0.1 dB, characteristic ±0.2 dB, characteristic ±0.3 dB, characteristic |

| | Specifications | Supplemental Information |
|--|----------------|--|
| Output VSWR 0 dB attenuation ≥ 8 dB attenuation | | <2.0:1, characteristic <1.5:1, characteristic |

| | Specifications | Supplemental Information |
|---|----------------|---|
| Output Attenuator Accuracy 0 dB 8 dB 16 dB 24 dB 32 dB 40 dB 48 dB 56 dB | Reference | ±0.5 dB, characteristic ±0.5 dB, characteristic ±0.5 dB, characteristic ±0.6 dB, characteristic ±0.8 dB, characteristic ±1.0 dB, characteristic ±1.1 dB, characteristic |

| |
|--|
| Tracking Generator Output Accuracy |
| Relative Accuracy (Referred to -20 dBm) = Output Attenuator Accuracy + Vernier Accuracy + Output Flatness |
| Absolute Accuracy = Relative Accuracy (Referred to -20 dBm) + Absolute Accuracy at 50 MHz |

Bluetooth™ FM Demodulation (Option 106)¹

The FM demodulation characteristics will apply after an Align Now, FM Demod has been run.

| | Specifications | Supplemental Information |
|-----------------------------|----------------|---|
| Optimum Input Level | | $\geq (-40 \text{ dBm} + \text{attenuator setting} - \text{preamp gain})$ and within 10 dB of the reference level |
| FM Deviation | | |
| Range | | $\pm 200 \text{ kHz}$, nominal |
| Resolution | | Provides 400 Hz display annotation resolution, nominal |
| Accuracy ^a | | |
| Input level = -30 dBm | | $\pm 10 \text{ kHz}$, typical |
| Reference level = -30 dBm | | $\pm 4 \text{ kHz}$ with video averaging On and averages ≥ 25 |
| FM Rate = 500 kHz sine | | |
| VBW = 3 MHz, | | |
| RBW = 5 MHz, | | |
| FM Deviation = 140 kHz | | |
| Offset Error ^a | | $\pm 1 \text{ kHz}$, typical |
| FM Bandwidth (-3 dB) | | 1.2 MHz, nominal |

a. In time domain sweeps (span = 0 Hz).

1. Bluetooth™ is a trademark owned by its proprietor and used by Agilent Technologies under license.

Bluetooth Measurements Personality (Option 228)

The demodulation related nominals will apply after an Align Now, FM Demod has been run.

| | Specifications | Supplemental Information |
|--------------------------------|--------------------|--------------------------|
| In-Band Frequency Range | | |
| Bluetooth (ISM) Band | 2400 to 2483.5 MHz | |

| | Specifications | Supplemental Information |
|--|---|--|
| Output Power (Option AYX or B7D) | | |
| Range at RF Input | 30 to -40 dBm | |
| (Option IDS) | 30 to -60 dBm | |
| Absolute Amplitude Accuracy | | Appendix , "Absolute Amplitude Accuracy," on page 59 |
| Average type | Video, Power | |
| Average mode | Exponential, Repeat | |
| Trigger source | Video, RF burst ^a , External, Free Run | |
| Burst synch | RF Amplitude, Preamble ^b , None | |

a. Requires Option B7E

b. Requires Option 106 Bluetooth FM demodulation.

| | Specifications | Supplemental Information |
|--|---------------------------------|--|
| Modulation Characteristics^a (Option 106 and AYX or B7D) | | |
| Range at RF Input | 30 to -40 dBm | |
| (Option IDS) | 30 to -60 dBm | |
| FM Deviation | | |
| Range | | ±200 kHz, nominal |
| Accuracy | | ±4 kHz, nominal (25 measurement averages, signal level > -30 dBm) |
| Payload data | 11110000, 10101010, auto-detect | |
| Average mode | Exponential, Repeat | |

Agilent E4402B Specifications and Characteristics
Options

| | Specifications | Supplemental Information |
|----------------|--|--------------------------|
| Trigger source | Video, RF burst ^b , External, Free Run | |
| Burst synch | RF Amplitude, Preamble ^c , None | |
| Limits | $\Delta f_2/\Delta f_1$ lower, Δf_1 max lower/upper Δf_2 | |

- a. The DUT must have frequency hopping disabled.
- b. Requires Option B7E
- c. Requires Option 106 Bluetooth FM demodulation.

| | Specifications | Supplemental Information |
|--|---|---|
| Carrier Frequency Drift ^a (Option 106 and AYW or B7D) | | |
| Range at RF Input | 30 to -40 dBm | |
| (Option 1DS) | 30 to -60 dBm | |
| Measurement range | | ± 100 kHz, nominal |
| Measurement accuracy | | ± 4 kHz, nominal (25 measurement averages, signal level > -30 dBm) |
| Average mode | Exponential, Repeat | |
| Trigger source | Video, RF burst ^b , External, Free Run | |
| Burst synch | Preamble ^c , None | |

- a. The DUT must have frequency hopping disabled.
- b. Requires Option B7E
- c. Requires Option 106 Bluetooth FM demodulation.

| | Specifications | Supplemental Information |
|---|----------------|---|
| Initial Carrier Frequency Tolerance (ICTF) ^a (Option 106 and AYW or B7D) | | |
| Range at RF Input | 30 to -40 dBm | |
| (Option 1DS) | 30 to -60 dBm | |
| Measurement range | | ± 100 kHz, nominal |
| Measurement accuracy | | ± 4 kHz, nominal (25 measurement averages, signal level > -30 dBm) |

| | Specifications | Supplemental Information |
|----------------|---|---------------------------------|
| Average mode | Exponential, Repeat | |
| Trigger source | Video, RF burst ^b , External, Free Run | |
| Burst synch | RF Amplitude, Preamble ^c , None | |
| Limits | ICFT upper/lower | |

- a. The DUT must have frequency hopping disabled.
- b. Requires Option B7E
- c. Requires Option 106 Bluetooth FM demodulation.

FM Demodulation (Option BAA)

The FM demodulation characteristics will apply after an **Align Now, FM Demod** has been run.

| | Specifications | Supplemental Information |
|---|----------------|---|
| Optimum Input Level | | $\geq (-60 \text{ dBm} + \text{attenuator setting} - \text{preamp gain})$ and within 30 dB of the reference level |
| FM Deviation | | |
| Range | | 10 kHz to 1 MHz |
| Resolution | | Provides 1 Hz display annotation resolution |
| FM Deviation Range | | |
| 10 kHz to 40 kHz | | 12 Hz, characteristic |
| >40 kHz to 200 kHz | | 60 Hz, characteristic |
| >200 kHz to 1 MHz | | 300 Hz, characteristic |
| Accuracy ^a | | |
| FM Rate < FM BW/100, VBW $\geq (30 \times \text{FM Rate})$, RBW > the maximum of (30 \times FM deviation) or (30 \times FM Rate) | | < (2% of FM deviation range + 2 \times Resolution), characteristic |
| Offset Error ^a | | 5% of FM Deviation Range + 300 Hz, characteristic |
| FM Bandwidth (-3 dB) | | |
| FM Deviation Range | | |
| 10 kHz to 40 kHz | | 7.5 \times FM deviation range, characteristic |
| >40 kHz to 200 kHz | | 1.3 \times FM deviation range, characteristic |
| >200 kHz to 1 MHz | | 0.3 \times FM deviation range, characteristic |

a. In time domain sweeps (span = 0 Hz).

TV Trigger and Picture On Screen (Option B7B)*Option BAA is required.*

| | Specifications | Supplemental Information |
|---|---|--|
| TV Trigger and Picture On Screen | | TV Trigger initiates a sweep of the analyzer after the sync pulse of a selected line of a TV video field. Picture On Screen displays the TV picture on the analyzer display. |
| Amplitude Requirements TV Source: SA | | Top 50% of linear display, characteristic |
| TV Source: EXT VIDEO IN | | 500 mV _{p-p} to 2 V _{p-p} , characteristic |
| Compatible Standards | NTSC-M, NTSC-Japan, PAL-M, PAL-B,D,G,H,I, PAL-N, PAL-N Combination, SECAM-L | |
| Field Selection | Entire frame, even, odd | |
| Sync Polarity | Positive or negative | |
| TV Trigger | | |
| Line Selection | 1 to 525, or 1 to 625, standard dependent | |

Options

cdmaOne Measurement Personality (Option BAC)

Unless otherwise noted, all specifications are with RF input range auto, default cdmaOne measurement settings, and in the in-band frequency range. *Option B72* is required.

| | Specifications | Supplemental Information |
|--------------------------------|--|--------------------------|
| In-Band Frequency Range | | |
| Cellular bands | 824 to 870 MHz 869 to 925 MHz | |
| PCS bands | 1715 to 1780 MHz 1805 to 1870 MHz 1850 to 1910 MHz 1930 to 1990 MHz | |

| | Specifications | Supplemental Information |
|---|----------------------------|---|
| Adjacent Channel Power Ratio^a | | |
| Carrier power range at RF Input | 30 to -20 dBm | |
| Dynamic range ^b | | Referenced to average power of carrier in 1.23 MHz BW |
| Offset Frequency | Integration BW | |
| 750 kHz | 30 kHz | -70.0 dBc, characteristic |
| 885 kHz | 30 kHz | -73.5 dBc, characteristic |
| 1.25625 MHz | 12.5 kHz | -78.0 dBc, characteristic |
| 1.98 MHz | 30 kHz | -75.5 dBc, characteristic |
| 2.75 MHz | 1 MHz | -60.5 dBc, characteristic |
| Relative accuracy ^c | See Display Scale Fidelity | |
| Resolution | 0.01 dB | |

- a. This measurement is available with personality revisions of A.02.00 or later.
- b. IS-97A nominal base station test model levels (fraction of carrier power); Pilot: 0.20 (-7.0 dBc), Sync: 0.0471 (-13.3 dBc), Paging: 0.1882 (-7.3 dBc), 6 Traffic channels: 0.09412 (-10.3 dBc)
- c. Does not include uncertainty due to noise.

| | Specifications | Supplemental Information |
|--|-----------------------|--------------------------------------|
| Channel Power (1.23 MHz Integration BW) | | Integration BW range 1 kHz to 10 MHz |
| Range at RF Input | 30 to -70 dBm | |
| Absolute power accuracy for in-band signal (Mean channel power at RF Input, plus any external attenuation, excluding mismatch error) | | |
| Cellular Bands | | |
| 30 to -5 dBm 20 to 30 °C | ±0.90 dB | ±0.39 dB, typical |
| 0 to 55 °C | ±1.23 dB | |
| -5 to -25 dBm 20 to 30 °C | ±0.86 dB | ±0.37 dB, typical |
| 0 to 55 °C | ±1.13 dB | |
| -25 to -45 dBm 20 to 30 °C | ±0.70 dB | ±0.21 dB, typical |
| 0 to 55 °C | ±0.96 dB | |
| -45 to -55 dBm 20 to 30 °C | ±0.78 dB | ±0.28 dB, typical |
| 0 to 55 °C | ±0.98 dB | |
| -55 to -70 dBm 20 to 30 °C | ±0.90 dB | ±0.38 dB, typical |
| 0 to 55 °C | ±1.23 dB | |
| PCS Bands | | |
| 30 to -5 dBm 20 to 30 °C | ±0.74 dB ^a | ±0.26 dB ^a , typical |
| 0 to 55 °C | ±1.15 dB ^a | |
| -5 to -25 dBm 20 to 30 °C | ±0.69 dB ^a | ±0.23 dB ^a , typical |
| 0 to 55 °C | ±1.03 dB ^a | |
| -25 to -45 dBm 20 to 30 °C | ±0.70 dB ^a | ±0.26 dB ^a , typical |
| 0 to 55 °C | ±1.00 dB ^a | |

Agilent E4402B Specifications and Characteristics
Options

| | Specifications | Supplemental Information |
|-------------------------------|----------------------------|--------------------------------------|
| -45 to -55 dBm 20 to 30 °C | ± 0.78 dB ^a | ± 0.33 dB ^a , typical |
| 0 to 55 °C | ± 1.02 dB ^a | |
| -55 to -70 dBm 20 to 30 °C | ± 0.90 dB ^a | ± 0.43 dB ^a , typical |
| 0 to 55 °C | ± 1.27 dB ^a | |

a. For Option UKB, add 0.10 dB.

| | Specifications | Supplemental Information |
|---|----------------------------|--------------------------|
| Channel power relative power accuracy (same channel, different Tx power, input attenuator fixed, RF input range manual). | See Display Scale Fidelity | |

| | Specifications | Supplemental Information |
|------------------------------|----------------------------|--------------------------------------|
| Receive Channel Power | | |
| Absolute Power Accuracy | | |
| Cellular bands | | |
| 30 to 0 dBm | ± 1.09 dB | ± 0.58 dB, typical |
| 0 to -85 dBm | ± 1.58 dB | ± 0.63 dB, typical |
| PCS bands | | |
| 30 to 0 dBm | ± 1.01 dB ^a | ± 0.53 dB ^a , typical |
| 0 to -85 dBm | ± 1.52 dB ^a | ± 0.58 dB ^a , typical |
| Preamp (<i>Option 1DS</i>) | | |
| Cellular bands | | |
| 30 to -80 dBm | ± 1.77 dB | ± 1.20 dB, typical |
| -80 to -100 dBm | ± 3.00 dB | ± 2.15 dB, typical |
| PCS bands | | |
| 30 to -80 dBm | ± 1.86 dB | ± 0.90 dB, typical |
| -80 to -100 dBm | ± 3.09 dB | ± 1.85 dB, typical |

a. For Option UKB, add 0.10 dB.

| | Specifications | Supplemental Information |
|--|----------------|--|
| Occupied Bandwidth | | |
| Carrier power range | 30 to -45 dBm | |
| Frequency resolution of occupied BW | 1.88 kHz | |
| Frequency accuracy of occupied BW (1.23 MHz channel BW) | | ±15 kHz, characteristic |
| Frequency resolution of delta frequency | 3.75 kHz | |
| Frequency accuracy of delta frequency | | ± (35 kHz + frequency reference error × carrier frequency), characteristic |

| | Specifications | Supplemental Information |
|---|--------------------|--|
| Code Domain Power (Requires <i>Options 1D5, B7D, and B7E</i> . Measurement interval ≥1.25 ms unless otherwise noted.) | | |
| Carrier power range at RF Input (Pilot channel power > -11 dBc) | 30 to -13 dBm | 30 to -65 dBm ^a , characteristic |
| Preamplifier (<i>Option 1DS</i>) | 30 to -30 dBm | 30 to -82 dBm ^a , characteristic |
| Measurement interval range | 0.5 ms to 26.67 ms | |
| Code domain power | | |
| Display dynamic range | 50 dB | |
| Accuracy (Walsh channel power within 20 dB of total power) | | ±0.2 dB, typical |
| Displayed resolution | 0.01 dB | |
| Other reported power parameters (dB referenced to total power) | | Average active traffic, maximum inactive traffic, average inactive traffic, pilot, paging, sync channels |

Agilent E4402B Specifications and Characteristics
Options

| | Specifications | Supplemental Information |
|---|------------------------|--|
| Carrier frequency error (Measurement interval ≥ 2.5 ms) | | Excludes frequency reference error. |
| Input frequency error range | ± 100 kHz | ± 200 kHz, typical |
| Accuracy | ± 10 Hz | ± 7 Hz, typical |
| Displayed resolution | Four digits | |
| Estimated Rho | | |
| Range | 0.9 to 1.0 | 0.5 to 1.0 ^b |
| Accuracy (With 9 channels active over the specified range) ^c | | ± 0.02 , characteristic |
| Displayed resolution | 0.0001 | |
| Pilot time offset | | From even second signal to start of PN sequence |
| Range | -13.33 ms to +13.33 ms | |
| Accuracy | ± 150 ns | |
| Displayed resolution | Four digits | |
| Code domain timing | | Pilot to code channel time tolerance |
| Range | ± 200 ns | |
| Accuracy (IS-97A nominal power levels) ^d | | ± 7 ns, typical |
| Code domain phase | | Pilot to code channel phase tolerance |
| Range | ± 200 mrad | |
| Accuracy (IS-97A nominal power levels) ^d | | ± 10 mrad, typical |
| Displays | | Power Graph and Metrics, or Power, Timing, and Phase Graphs |

- Performance may degrade outside of the specified carrier power range at RF input listed in the specifications column.
- Performance may degrade outside of the estimated rho range listed in the specifications column.
- The Active Set Threshold is less than all active channels, but greater than -20 dBc.
- IS-97A nominal base station test model levels (fraction of carrier power); Pilot: 0.20 (-7.0 dBc), Sync: 0.0471 (-13.3 dBc), Paging: 0.1882 (-7.3 dBc), 6 Traffic channels: 0.09412 (-10.3 dBc)

| | Specifications | Supplemental Information |
|---|------------------------|---|
| Modulation Accuracy (Rho) (Requires <i>Options 1D5, B7D, and B7E</i> . Measurement interval ≥ 1.25 ms unless otherwise noted.) | | |
| Carrier power range at RF Input | 30 to -28 dBm | 30 to -70 dBm ^a , characteristic |
| Preamp (<i>Option 1D5</i>) | 30 to -45 dBm | 30 to -87 dBm ^a , characteristic |
| Measurement interval range | 0.15 ms to 26.67 ms | |
| Rho (waveform quality) | | |
| Range | 0.9 to 1.0 | 0.5 to 1.0 ^b , characteristic |
| Accuracy | | ± 0.0016 , typical |
| Displayed resolution | 0.0001 | |
| Carrier frequency error (Measurement interval ≥ 2.5 ms) | | Excludes frequency reference error |
| Input frequency error range | ± 100 kHz | ± 200 kHz, typical |
| Accuracy | ± 10 Hz | ± 7 Hz, typical |
| Displayed resolution | Four digits | |
| Pilot time offset | | From even second signal to start of PN sequence |
| Range | -13.33 ms to +13.33 ms | |
| Accuracy | ± 150 ns | |
| Displayed resolution | Four digits | |
| EVM | | |
| Floor | | 3.8%, typical |
| Accuracy ^c | | $\pm 1.1\%$, typical |
| Displayed Resolution | 0.01% | |
| Carrier feedthrough | | |
| Floor | | -51 dBc, typical |
| Accuracy (Carrier feedthrough ≥ -43 dBc) | | ± 2.3 dB, typical |
| Displayed resolution | 0.01 dB | |

Agilent E4402B Specifications and Characteristics
Options

| | Specifications | Supplemental Information |
|------------------------|----------------|--|
| Magnitude error | | |
| Floor | | 3.8%, typical |
| Accuracy ^c | | ±1.1%, typical |
| Displayed resolution | 0.01% | |
| Phase error | | |
| Accuracy ^c | | ±0.65 degrees, typical |
| Displayed resolution | 0.01 degrees | |
| Displays | | Numeric results or Numeric results and IQ graph |

- a. Performance may degrade outside of the specified carrier power range at RF input listed in the specifications column.
- b. Performance may degrade outside of the rho range listed in the specifications column.
- c. Accuracy does not include the effects of the EVM floor. The measurement variance increases as the result approaches the EVM floor.

| | Specifications | Supplemental Information |
|---------------------------------|--|---|
| Spur Close (In Band) | | |
| Carrier power range at RF Input | 30 to -12 dBm | |
| Dynamic range | | |
| Input power | | |
| 30 to 25 dBm | 55 dB | |
| 25 to 20 dBm | 50 dB | |
| 20 to -12 dBm | 46 dB | |
| Relative accuracy | ±(2.7 dB + 0.01 × (dB from reference level)) | ±(0.3 dB + 0.01 × (dB from reference level)), typical |
| Displayed resolution | 0.01 dB | |

| | Specifications | Supplemental Information |
|---|----------------|--|
| Out-of-Band Spurious^a | | Refer to the Amplitude specifications section in this guide. |

- a. The out-of-band measurement is made with the user-defined tables with 20 frequency ranges each (up to the top 10 spurs per range, 100 spurs maximum). Table parameters include frequency range, RBW, video BW, detector type, and amplitude test limits.

| | Specifications | Supplemental Information |
|---|----------------------|--------------------------------|
| Receiver Spurious Emissions | | |
| Spurious emission power range | -20 to -83 dBm | |
| Preamp On (<i>Option IDS</i>) | -40 to -101 dBm | |
| Absolute spurious emission power accuracy | | |
| -20 to -60 dBm | ±2.2 dB ^a | ±1.1 dB ^a , typical |
| -60 to -83 dBm | ±3.9 dB ^a | ±2.7 dB ^a , typical |
| Preamp On (<i>Option IDS</i>) | | |
| -40 to -70 dBm | ±2.6 dB | ±1.4 dB, typical |
| -70 to -101 dBm | ±4.1 dB | ±2.8 dB, typical |

a. For Option UKB, add 0.10 dB.

| | Specifications | Supplemental Information |
|--|----------------|--------------------------|
| External Correction | | |
| External attenuation, external gain | | |
| Range | -90 to 90 dB | |
| Resolution | 0.01 dB | |

| | Specifications | Supplemental Information |
|--|---------------------|---|
| Trigger | | |
| Trigger source (Actual available choices dependent on measurement) | Free run, external | |
| (<i>Option B7D and B7E</i>) | Add RF Burst, frame | |
| Delay trigger | | |
| Range | 0 to 500 ms | |
| Resolution | 300 ns | |
| RF burst trigger level (<i>Option B7E</i>) | 0 to -25 dBc | |
| Trigger slope (External and RF burst) | Positive/Negative | |
| Frame timing period | 50 ns to 13.6533 s | |
| Frame synchronizing source | External frame sync | Rear panel connector labelled EXT FRAME SYNC (<i>Option B7D</i>) |
| Frame synchronizing slope | Positive/Negative | |

Agilent E4402B Specifications and Characteristics
Options

| | Specifications | Supplemental Information |
|---|---|---|
| Demod Trigger Source Even second input (Frame trigger only, <i>Option B7D</i> and <i>B7E</i>) PN offset range | 0 to 511 x 64 [chips] | Rear panel connector labelled EXT FRAME SYNC |

GSM Measurement Personality (Option BAH)

Unless otherwise noted, all specifications are with RF input range auto, default GSM measurement settings, and in the in-band frequency range. *Option 1D6* and *Option B72* are required.

| | Specifications | Supplemental Information |
|--------------------------------|--------------------------------------|--------------------------|
| In-Band Frequency Range | | |
| GSM 900, P-GSM bands | 890 to 915 MHz 935 to 960 MHz | |
| GSM 900, E-GSM bands | 880 to 915 MHz 925 to 960 MHz | |
| GSM 900, R-GSM bands | 876 to 915 MHz 921 to 960 MHz | |
| DCS 1800 bands | 1710 to 1785 MHz 1805 to 1880 MHz | |
| PCS 1900 bands | 1850 to 1910 MHz 1930 to 1990 MHz | |

| | Specifications | Supplemental Information |
|--|----------------|--------------------------|
| Transmitter Power (Requires <i>Option B7D</i> or <i>AYX</i>) | | |
| Range at RF Input | 30 to -60 dBm | |
| Absolute power accuracy for in-band signal (Mean channel power at RF Input, plus any external attenuation, excluding mismatch error) | | |
| P-GSM, E-GSM, and R-GSM Bands | | |
| 30 to -20 dBm 20 to 30 °C | ±0.99 dB | ±0.44 dB, typical |
| 0 to 55 °C | ±1.49 dB | |
| -20 to -30 dBm 20 to 30 °C | ±0.92 dB | ±0.38 dB, typical |
| 0 to 55 °C | ±1.23 dB | |

Agilent E4402B Specifications and Characteristics
Options

| | Specifications | Supplemental Information |
|-------------------------------|-----------------------|---------------------------------|
| -30 to -40 dBm 20 to 30 °C | ±0.97 dB | ±0.39 dB, typical |
| 0 to 55 °C | ±1.22 dB | |
| -40 to -50 dBm 20 to 30 °C | ±1.16 dB | ±0.57 dB, typical |
| 0 to 55 °C | ±1.35 dB | |
| -50 to -60 dBm 20 to 30 °C | ±1.29 dB | ±0.70 dB, typical |
| 0 to 55 °C | ±1.46 dB | |
| DCS 1800 and PCS 1900 Bands | | |
| 30 to -20 dBm 20 to 30 °C | ±0.83 dB ^a | ±0.31 dB ^a , typical |
| 0 to 55 °C | ±1.41 dB ^a | |
| -20 to -30 dBm 20 to 30 °C | ±0.75 dB ^a | ±0.28 dB ^a , typical |
| 0 to 55 °C | ±1.08 dB ^a | |
| -30 to -40 dBm 20 to 30 °C | ±0.80 dB ^a | ±0.29 dB ^a , typical |
| 0 to 55 °C | ±1.07 dB ^a | |
| -40 to -50 dBm 20 to 30 °C | ±0.99 dB ^a | ±0.47 dB ^a , typical |
| 0 to 55 °C | ±1.20 dB ^a | |
| -50 to -60 dBm 20 to 30 °C | ±1.12 dB ^a | ±0.60 dB ^a , typical |
| 0 to 55 °C | ±1.31 dB ^a | |

a. For Option UKB, add 0.10 dB.

| | Specifications | Supplemental Information |
|---|----------------------------|--------------------------|
| Transmitter Power Relative Power Accuracy (same channel, different Tx power, input attenuator fixed, RF input range manual). | See Display Scale Fidelity | |

| | Specifications | Supplemental Information |
|---|----------------|---|
| Power versus Time (Requires <i>Option B7D</i> or <i>AYX</i>) | | |
| Carrier power range at RF Input | 30 to -23 dBm | 30 to -55 dBm ^a , characteristic |
| Preamp On (<i>Option 1DS</i>) | 30 to -40 dBm | 30 to -72 dBm ^a , characteristic |
| Time resolution accuracy | | ±1% of sweep time, characteristic |
| Maximum record length | 8 time slots | |
| Burst to mask uncertainty (Requires <i>Option B7D</i> and <i>B7E</i>) | ±1.0 bit | |

a. Performance may degrade outside of the specified carrier power range at RF input listed in the specifications column.

| | Specifications | Supplemental Information |
|--|---------------------------------------|------------------------------|
| Output RF Spectrum | | |
| Carrier power range at RF Input | | |
| Offsets ≤1800 kHz, 30 kHz RBW | | 30 to -5 dBm, characteristic |
| Offsets >1800 kHz, 100 kHz RBW | | 30 to -4 dBm, characteristic |
| Reference power accuracy | Same as Transmitter Power measurement | |
| Relative accuracy ^a | See Display Scale Fidelity | |
| Spectrum due to modulation displayed dynamic range ^{b,c} | | |
| 100 kHz offset | | 30 dB, characteristic |
| 200 kHz offset | | 60 dB, characteristic |
| 250 kHz offset | | 60 dB, characteristic |
| 400 kHz offset | | 70 dB, characteristic |
| 600 kHz to 1.8 MHz offset | | 79 dB, characteristic |
| 1.8 to 6.0 MHz offset | | 75 dB, characteristic |
| > 6 MHz offset | | 76 dB, characteristic |
| Swept Mode Dynamic Range | | 70 dB, characteristic |

| | Specifications | Supplemental Information |
|---|----------------|--------------------------|
| Spectrum due to switching transients displayed dynamic range ^{b,c} | | |
| 400 kHz offset | | 62 dB, characteristic |
| 600 kHz offset | | 79 dB, characteristic |
| 1200 kHz offset | | 79 dB, characteristic |
| 1800 kHz offset | | 80 dB, characteristic |
| Swept Mode Dynamic Range | | 70 dB, characteristic |

- a. Does not include uncertainty due to noise.
- b. Displayed dynamic range for specific frequency offsets—applies to CW signal at the specified offset. Dynamic range with a GSM signal may differ.
- c. Using default settings, the RBW filter has a corrected noise BW and impulse BW equivalent to five-pole synchronously tuned filter.

| | Specifications | Supplemental Information |
|---|----------------|---|
| Phase and Frequency Error (Requires <i>Option 1D5, B7D, and B7E</i>) | | |
| Carrier power range at RF Input | 30 to -23 dBm | 30 to -55 dBm ^a , characteristic |
| Preamp On (<i>Option 1DS</i>) | 30 to -40 dBm | 30 to -72 dBm ^a , characteristic |
| Phase error | | |
| Range | 0 to 180° | |
| Displayed resolution | 0.01° | |
| Accuracy (Averages ≥10) | | |
| Peak | ±2.1° | ±1.5°, typical |
| RMS | ±1.1° | ±0.6°, typical |
| Frequency error | | Excludes frequency reference error |
| Initial frequency error range | ±100 kHz | |
| Accuracy (Averages ≥10) | ±10 Hz | ±5 Hz, typical |
| I/Q offset range | -10 to -46 dBc | |
| Burst sync time uncertainty | ±0.1 bit | |
| Displays | | Numeric summary |

- a. Performance may degrade outside of the specified carrier power range at RF input listed in the specifications column.

| | Specifications | Supplemental Information |
|-----------------------------------|----------------|---|
| Transmit Band Spurious | | |
| Carrier power range at RF Input | | 30 to -12 dBm, typical |
| Dynamic range | | |
| Upper and lower adjacent segments | | 55 dB, characteristic |
| Upper and lower segments | | 44 dB, characteristic |
| Relative accuracy | | $\pm(0.3 \text{ dB} + 0.01 \times (\text{dB from reference level}))$, characteristic |
| Displayed resolution | 0.01 dB | |

| | Specifications | Supplemental Information |
|---|----------------|--|
| Out-of-Band Spurious^a | | |
| Absolute Spurious Power Accuracy | | Refer to the Amplitude specifications section in this guide. |
| Sensitivity ^b | | |
| RBW | | |
| 1 kHz | | -95 dBm, characteristic |
| 3 kHz | | -90 dBm, characteristic |
| 10 kHz | | -85 dBm, characteristic |
| 30 kHz | | -78 dBm, characteristic |
| 100 kHz | | -71 dBm, characteristic |
| 300 kHz | | -64 dBm, characteristic |
| 1 MHz | | -57 dBm, characteristic |
| 3 MHz | | -50 dBm, characteristic |

- a. The out-of-band spurious measurement is made in accordance with the tables defined in the appropriate GSM specification document. The measurement is made over several frequency ranges (up to 10 spurs per range, 100 spurs maximum).
- b. With input attenuation of 5 dB. For all other attenuation settings, add (input attenuation - 5) dB.

| | Specifications | Supplemental Information |
|--|----------------|--------------------------------|
| Receive Band Spurious | | |
| Spurious emission power range ^a | | -20 to -73 dBm, characteristic |
| Preamp On (<i>Option 1DS</i>) | | -40 to -91 dBm, characteristic |

Agilent E4402B Specifications and Characteristics
Options

| | Specifications | Supplemental Information |
|---|----------------|---------------------------------------|
| Absolute spurious emission power accuracy | | |
| –20 to –60 dBm | | ±1.5 dB ^b , characteristic |
| –60 to –73 dBm | | ±2.1 dB ^b , characteristic |
| Preamp on (<i>Option 1DS</i>) | | |
| –40 to –70 dBm | | ±1.9 dB, characteristic |
| –70 to –91 dBm | | ±3.1 dB, characteristic |

- a. Requires bandpass filter centered on receive band, peak detector mode, 0 dB attenuation, 100 kHz RBW. Does not include insertion loss of bandpass filter.
b. For Option UKB, add 0.10 dB.

| | Specifications | Supplemental Information |
|--------------------------------|----------------|---|
| Amplitude Range Control | | RF Input Autorange, Manually set Max Total Pwr Manually set Input Atten |

| | Specifications | Supplemental Information |
|--|----------------|--------------------------|
| External Gain/Attenuation Correction | | |
| Base gain, base attenuation, mobile gain, mobile attenuation | | |
| Range | 0 to 81.9 dB | |
| Resolution | 0.01 dB | |

| | Specifications | Supplemental Information |
|--|-------------------------------------|--------------------------|
| Trigger | | |
| Trigger source (Actual available choices dependent on measurement) | Free run, external | |
| (<i>Option B7D and B7E</i>) | Add RF Burst and frame | |
| RF burst trigger (<i>Option B7E</i>) | | |
| Peak carrier power range ^a | 30 to –25 dBm | 30 to –30 dBm, typical |
| Preamp On (<i>Option 1DS</i>) | 30 to –45 dBm | 30 to –50 dBm, typical |
| Trigger level range | 0 to –25 dB relative to signal peak | |

- a. With trigger level set to –6 dB.

| | Specifications | Supplemental Information |
|--|---|--|
| Burst Sync (Requires <i>Option AYX</i> or <i>B7D</i>) Source (Actual available choices dependent on measurement) (<i>Option B7D</i> and <i>B7E</i>) Training sequence code Burst type | RF amplitude, none Add training sequence | GSM defined 0 to 7 Auto (search) or Manual Normal (TCH and CCH) Sync (SCH) Access (RACH) |

General

| | Specifications | Supplemental Information |
|--------------------------|----------------|--------------------------|
| Temperature Range | | |
| Operating | 0 to 55 °C | Floppy disk 10 to 40 °C |
| Storage | -40 to 75 °C | |

| | Specifications | Supplemental Information |
|-------------------------------------|----------------|----------------------------|
| Audible Noise (ISO 7779) | | |
| Sound Pressure at 25 °C | | <40 dBa, (<4.6 Bels power) |

| | Specifications | Supplemental Information |
|-------------------------------|---|--------------------------|
| Military Specification | Has been type tested to the environmental specifications of MIL-PRF-28800F class 3. | |

| | Specifications | Supplemental Information |
|---------------------------------|---|--------------------------|
| EMI Compatibility | Conducted and radiated emission is in compliance with CISPR Pub. 11/1990 Group 1 Class A. | |
| <i>(Option 060)^a</i> | Conducted and radiated emission is in compliance with CISPR Pub. 11/1990 Group 1 Class B ^b . | |

- a. Option 060 is not compatible with Option B7B nor Option 1DP.
- b. Meets Class A performance during dc operation.

| | Specifications | Supplemental Information |
|-------------------------|----------------|---|
| Immunity Testing | | |
| Radiated Immunity | | Testing was done at 3 V/m according to IEC 801-3/1984. When the analyzer tuned frequency is identical to the immunity test signal frequency, there may be signals of up to -60 dBm displayed on the screen. |

| | Specifications | Supplemental Information |
|-------------------------|----------------|---|
| Electrostatic Discharge | | Air discharges of up to 8 kV were applied according to IEC 801-2/1991. Discharges to center pins of any of the connectors may cause damage to the associated circuitry. |

| | Specifications | Supplemental Information |
|----------------------------|--|--------------------------|
| Power Requirements | | |
| ac Operation | | |
| Voltage, frequency | 90 to 132 Vrms, 47 to 440 Hz 195 to 250 Vrms, 47 to 66 Hz | |
| Power Consumption, On | <300 W | |
| Power Consumption, Standby | <5 W | |
| dc Operation | | |
| Voltage | 12 to 20 Vdc | |
| Power Consumption | <200 W | |
| Power Consumption, Standby | <100 mW | |

| | Specifications | Supplemental Information |
|--|----------------|--------------------------|
| Measurement Speed | | |
| Local Measurement and Display Update rate ^a | | |
| Sweep points = 101 | | ≥ 45/s, characteristic |
| Sweep points = 401 | | ≥ 30/s, characteristic |
| Remote Measurement and GPIB Transfer Rate ^{b,c} | | |
| <i>(Option A4H)</i> | | |
| Sweep points = 101 | | ≥ 45/s, characteristic |
| Sweep points =401 | | ≥ 30/s, characteristic |

Agilent E4402B Specifications and Characteristics
General

| | Specifications | Supplemental Information |
|--|----------------|--|
| RF Center Frequency Tune, Measure, and GPIB Transfer Time ^{b,d} (Option A4H) Sweep points = 101 Sweep points = 401 | | ≤ 75 ms, characteristic ≤ 90 ms, characteristic |

- a. Factory preset, auto align Off, segmented sweep Off, fixed center frequency, RBW = 1 MHz, and spans >10 MHz and ≤600 MHz.
- b. Display Off (:DISPlay:ENABle OFF), and 32-bit integer data format (:FORMat:DATA INT,32), if Option AYX or AAJ is installed, disable sweep ramp, (:SYSTem:PORTs:IFVSweep:ENABle OFF), markers Off, single sweep, measured with IBM compatible PC with 550 MHz Pentium® III running Windows® NT 4.0, one meter GPIB cable, National Instruments PCI-GPIB card and NI-488.2 DLL.
- c. Factory preset, auto align Off, segmented sweep Off, RBW = 1 MHz, span= 20 MHz, fixed center frequency, average of 100 measurements.
- d. Factory preset, auto align Off, segmented sweep Off, RBW = 1 MHz, span= 20 MHz, and center frequency tune step size = 50 MHz.

| | Specifications | Supplemental Information |
|---|----------------|--|
| Data Storage Internal External (10 to 40 °C) 3.5" 1.44 MB, MS-DOS® compatible floppy disk | | 200 Traces or States ^a 200 Traces or States ^a |

- a. When storing traces set to 401 points.

| | Specifications | Supplemental Information |
|--|----------------|---|
| Downloadable Program Memory (Option B72) | | 2 MB available memory 10 MB available memory |

| | Specifications | Supplemental Information |
|--|------------------|---|
| Demod Tune and Listen Demod (Option BAA or 106) | AM Add FM | Internal speaker, front-panel earphone jack and front-panel volume control. |

| | Specifications | Supplemental Information |
|----------------------------|----------------|---|
| <i>(Option A4J or AYX)</i> | | An uncalibrated demodulated signal is available on the AUX VIDEO OUT connector at the rear panel. |
| <i>(Option 106 or BAA)</i> | | An uncalibrated demodulated signal is available on the EXT VIDEO OUT connector at the rear panel. |

| | Specifications | Supplemental Information |
|---------------------------------|----------------|-----------------------------------|
| Weight (without options) | | |
| Net | | 15.5 kg (34.2 lb), characteristic |
| Shipping | | 27.4 kg (60.4 lb), characteristic |

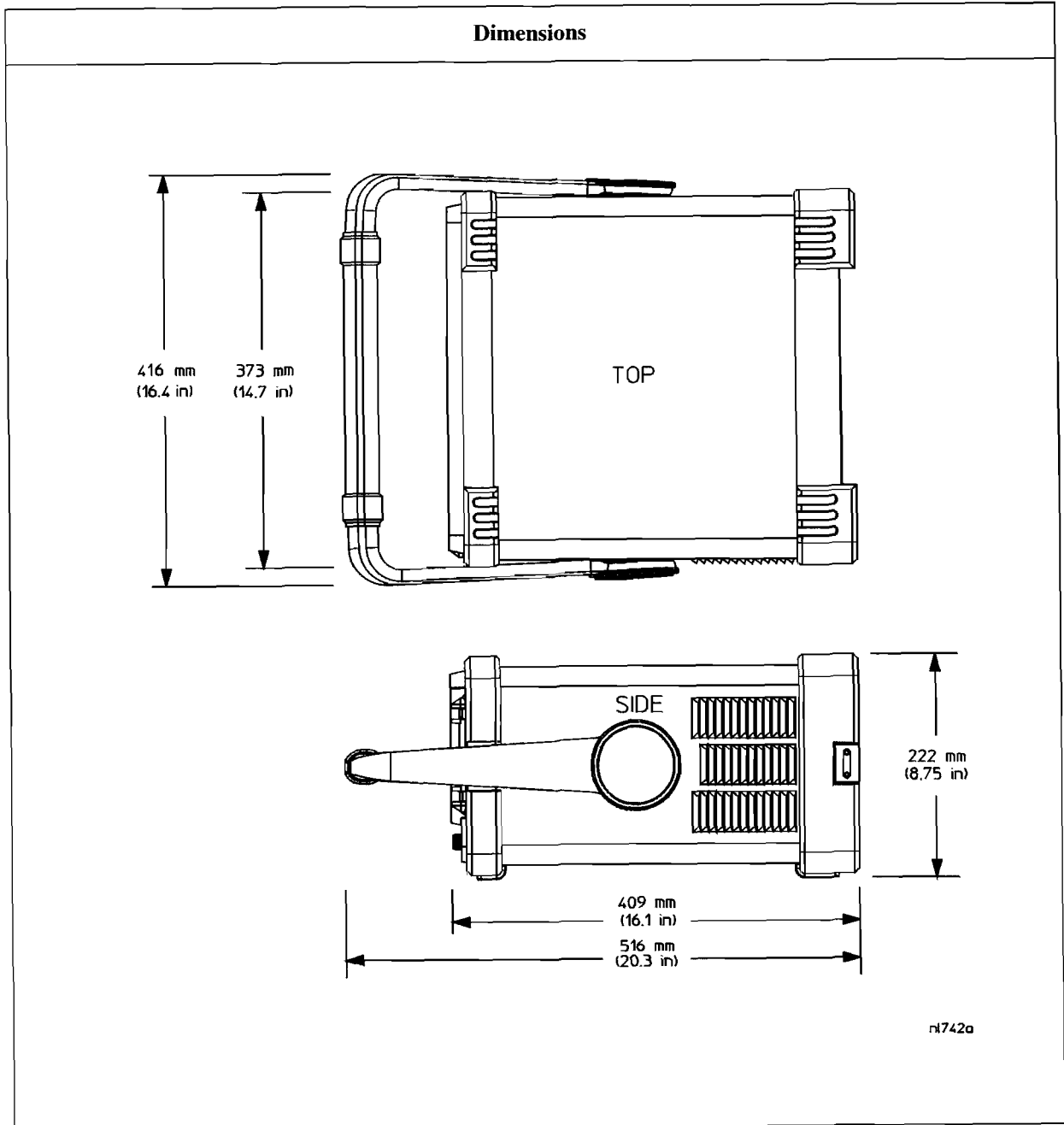

Inputs and Outputs

Front Panel

| | Specifications | Supplemental Information |
|-------------------|----------------|---|
| INPUT 50 Ω | | |
| Connector | Type-N female | |
| Impedance | | 50 Ω, nominal |
| LO Emissions | | < -70 dBm, characteristic. Average level of 1st LO, 3.9214 to 6.9214 GHz, present at INPUT 50 Ω connector. |

| | Specifications | Supplemental Information |
|----------------------------------|----------------|--------------------------|
| RF OUT 50 Ω, (Option 1DN) | | |
| Connector | Type-N female | |
| Impedance | | 50 Ω, nominal |

| | Specifications | Supplemental Information |
|----------------------------------|----------------|--|
| AMPTD REF OUT^a | | Amplitude Reference |
| Connector | BNC female | |
| Impedance | | 50 Ω, nominal |
| Frequency | | 50 MHz |
| Frequency Accuracy | | Frequency reference error ^b |
| 50 Ω Amplitude ^c | | -20 dBm, nominal |

- Turn the amplitude reference on/off by pressing the keys: **Input/Output, Amptd Ref Out**.
- Frequency reference error = (aging rate × period of time since adjustment + settability + temperature stability).
- The internal amplitude reference actual power is stored internally.

| | Specifications | Supplemental Information |
|--------------------|----------------|--|
| PROBE POWER | | |
| Voltage/Current | | +15 Vdc, ±7% at 150 mA max., characteristic -12.6 Vdc ±10% at 150 mA max., characteristic |

Agilent E4402B Specifications and Characteristics
Inputs and Outputs

| | Specifications | Supplemental Information |
|---------------------------------|----------------|---|
| EXT KEYBOARD^a | | Used for entering screen titles and filenames only. Interface compatible with most IBM-compatible PC keyboards. |
| Connector | 6-pin mini-DIN | |

a. The feature is not implemented in firmware revisions prior to A.04.00.

| | Specifications | Supplemental Information |
|----------------|----------------|----------------------------------|
| Speaker | | Front panel knob controls volume |

| | Specifications | Supplemental Information |
|------------------|--|--|
| Headphone | | Front panel knob controls volume |
| Connector | 3.5 mm (1/8 inch) miniature audio jack | |
| Power Output | | 0.2 W into 4 Ω , characteristic |

Rear Panel

| | Specifications | Supplemental Information |
|-----------------------|----------------|--------------------------|
| 10 MHz REF OUT | | |
| Connector | BNC female | |
| Impedance | | 50 Ω , nominal |
| Output Amplitude | | >0 dBm, characteristic |

| | Specifications | Supplemental Information |
|-----------------------|----------------|---|
| 10 MHz REF IN | | |
| Connector | BNC female | Note: Analyzer noise sidebands and spurious response performance may be affected by the quality of the external reference used. |
| Impedance | | 50 Ω , nominal |
| Input Amplitude Range | | -15 to +10 dBm, characteristic |
| Frequency | | 10 MHz, nominal |

| | Specifications | Supplemental Information |
|--|--|---------------------------------|
| EXT REF IN <i>(Option B7E)</i> | | |
| Connector | BNC, female | 50 Ω, nominal |
| Impedance | | |
| Input amplitude range | -5 to 10 dBm | |
| Frequency | 1 to 30 MHz, selectable | |
| Frequency lock range | $\pm 5 \times 10^{-6}$ of specified external reference input frequency | |

| | Specifications | Supplemental Information |
|--|-----------------------|--|
| 10 MHz OUT <i>(Option B7E)</i> | | |
| Connector | BNC, female | 50 Ω, nominal 10 MHz, nominal 0 dBm when Option 10 MHz Out is On |
| Impedance | | |
| Frequency | | |
| Level | | |

| | Specifications | Supplemental Information |
|--|-----------------------|---|
| GATE TRIG/EXT TRIG IN | | |
| Connector | BNC female | Selectable positive or negative edge initiates sweep in EXT TRIG mode (5 V TTL) >30 ns (5 V TTL) |
| External Trigger Input | | |
| Trigger Level | | |
| Gate Trigger Input <i>(Option 1D6)</i> | | |
| Minimum Pulse Width | | |

Agilent E4402B Specifications and Characteristics
Inputs and Outputs

| | Specifications | Supplemental Information |
|---|----------------|---|
| GATE/HI SWP OUT | | |
| Connector | BNC female | |
| High Sweep Output Level | | High = sweep ^a ; Low = retrace (5 V TTL) |
| Gate Output (<i>Option 1D6</i>) Level | | High = gate on; Low = gate off (5 V TTL) |

a. High sweep may be high longer than the indicated sweep times.

| | Specifications | Supplemental Information |
|-------------------|-----------------------------------|--|
| VGA OUTPUT | | |
| Connector | VGA compatible, 15-pin mini D-SUB | |
| Format | | VGA (31.5 kHz horizontal, 60 Hz vertical sync rates, non-interlaced) Analog RGB |
| Resolution | 640 × 480 | |

| | Specifications | Supplemental Information |
|--|----------------|---------------------------------------|
| AUX IF OUT (<i>Option A4J or AYX</i>) | | RBW ≥ 1 kHz |
| Connector | BNC female | |
| Frequency | | 21.4 MHz, nominal |
| Amplitude (for signal at reference level and for reference levels – input attenuation + preamp gain of –10 to –70 dBm) | | –10 dBm (uncorrected), characteristic |
| Impedance | | 50 Ω, nominal |

| | Specifications | Supplemental Information |
|--|-----------------------|--|
| AUX VIDEO OUT <i>(Option A4J or AYX)</i> | | RBW \geq 1 kHz |
| Connector | BNC female | |
| Amplitude Range (into $>10\text{ k}\Omega$) | | 0 to 1 V (uncorrected), characteristic |

| | Specifications | Supplemental Information |
|--|-----------------------|--|
| HI SWP IN <i>(Option A4J or AYX)</i> | | |
| Connector | BNC female | |
| Input | | Open collector, low resets and holds the sweep (5 V TTL) |

| | Specifications | Supplemental Information |
|---|-----------------------|---|
| HI SWP OUT <i>(Option A4J or AYX)</i> | | |
| Connector | BNC female | |
| Output | | High = sweep ^a , Low = retrace (5 V TTL) |

a. High sweep may be high longer than the indicated sweep times.

| | Specifications | Supplemental Information |
|--|-----------------------|---------------------------------|
| SWP OUT <i>(Option A4J or AYX)</i> | | |
| Connector | BNC female | |
| Amplitude | | 0 to +10 V ramp, characteristic |

| | Specifications | Supplemental Information |
|--|------------------------|--|
| GPIB Interface <i>(Option A4H)</i> | | |
| Connector | IEEE-488 bus connector | |
| GPIB Codes | | SH1, AH1, T6, SR1, RL1, PP0, DC1, C1, C2, C3 and C28 |

Agilent E4402B Specifications and Characteristics
Inputs and Outputs

| | Specifications | Supplemental Information |
|---|------------------|--------------------------|
| Serial Interface (<i>Option 1AX</i>) | | |
| Connector | 9-pin D-SUB male | RS-232 |

| | Specifications | Supplemental Information |
|---|---------------------|--------------------------|
| Parallel Interface (<i>Option A4H or 1AX</i>) | | Printer port only |
| Connector | 25-pin D-SUB female | |

| | Specifications | Supplemental Information |
|--|-------------------|--|
| EXT VIDEO IN/TV TRIG OUT^a (<i>Option B7B or BAA</i>) | | EXT VIDEO IN is the Baseband composite video input for TV trigger and picture on screen. TV TRIG OUT is the TV trigger output. |
| Connector | BNC Female (75 Ω) | |
| Impedance | | 75 Ω, nominal |
| (<i>Option BAA without Option B7B</i>) | | Feature not implemented |
| (<i>Option BAA with Option B7B</i>) | | |
| External Video Input Video Amplitude | | 1 V _{p-p} , nominal, characteristic |
| TV Trigger Output | | Positive edge indicates start of selected TV line after sync. pulse |
| Amplitude | | TTL (0 V and 3.4 V with 75 Ω series resistance), characteristic |

a. This connector is labelled EXT VIDEO IN on older spectrum analyzers and EXT VIDEO IN/TV TRIG OUT on newer spectrum analyzers.

| | Specifications | Supplemental Information |
|--|-------------------|--------------------------------------|
| EXT VIDEO OUT (<i>Option B7B or BAA</i>) | | Baseband video output RBW ≥ 1 kHz |
| Connector | BNC female (75 Ω) | |
| Impedance | | 75 Ω, nominal |

| | Specifications | Supplemental Information |
|---|--------------------------|---|
| <p><i>(Option BAA without Option B7B)</i></p> <p>Amplitude</p> <p><i>(Option BAA with Option B7B)</i></p> <p>Amplitude</p> <p>TV Source: SA</p> <p>TV Source and EXT VIDEO IN</p> <p><i>(Option 106)</i></p> <p>Connector</p> <p>Impedance</p> <p>Amplitude</p> | <p>BNC female (75 Ω)</p> | <p>0 to 1 V (uncorrected), characteristic</p> <p>0 to 1 V (uncorrected), characteristic</p> <p>Same as level at EXT VIDEO IN/TV TRIG OUT, characteristic</p> <p>75 Ω, nominal</p> <p>0 to 1 V (uncorrected), characteristic</p> |

| | Specifications | Supplemental Information |
|---|-----------------------|---------------------------------|
| <p>EXT FRAME SYNC</p> <p><i>(Option B7D)</i></p> <p>Connector</p> <p>Level</p> | <p>BNC, female</p> | <p>5 V TTL</p> |

Regulatory Information

CAUTION

This product is designed for use in Installation Category II and Pollution Degree 2 per IEC 1010 and 664 respectively.

NOTE

This product has been designed and tested in accordance with IEC Publication 1010, Safety Requirements for Electronic Measuring Apparatus, and has been supplied in a safe condition. The instruction documentation contains information and warnings which must be followed by the user to ensure safe operation and to maintain the product in a safe condition.



The CE mark is a registered trademark of the European Community (if accompanied by a year, it is the year when the design was proven).



The CSA mark is the Canadian Standards Association safety mark.

ISM 1-A

This is a symbol of an Industrial Scientific and Medical Group 1 Class A product. (CISPR 11, Clause 4)

Declaration of Conformity

| DECLARATION OF CONFORMITY According to ISO/IEC Guide 22 and CEN/CENELEC EN 45014 | |
|---|---|
| Manufacturer's Name: | Agilent Technologies, Inc. |
| Manufacturer's Address: | 1400 Fountaingrove Parkway Santa Rosa, CA 95403-1799 USA |
| Declares that the products | |
| Product Name: | Spectrum Analyzer |
| Model Number: | E4401B, E4402B, E4403B, E4404B, E4405B, E4407B, E4408B, E4411B |
| Product Options: | This declaration covers all options of the above products. |
| Conform to the following product specifications: | |
| EMC: IEC 61326-1:1997+A1:1998 / EN 61326-1:1997+A1:1998 | |
| <u>Standard</u> | <u>Limit</u> |
| CISPR 11:1990 / EN 55011-1991 | Group 1, Class A |
| IEC 61000-4-2:1995+A1998 / EN 61000-4-2:1995 | 4 kV CD, 8 kV AD |
| IEC 61000-4-3:1995 / EN 61000-4-3:1995 | 3 V/m, 80 - 1000 MHz |
| IEC 61000-4-4:1995 / EN 61000-4-4:1995 | 0.5 kV sig., 1 kV power |
| IEC 61000-4-5:1995 / EN 61000-4-5:1996 | 0.5 kV L-L, 1 kV L-G |
| IEC 61000-4-6:1996 / EN 61000-4-6:1998 | 3 V, 0.15 - 80 MHz |
| IEC 61000-4-11:1994 / EN 61000-4-11:1998 | 1 cycle, 100% |
| Safety: IEC 61010-1:1990 + A1:1992 + A2:1995 / EN 61010-1:1993 +A2:1995 CAN/CSA-C22.2 No. 1010.1-92 | |
| Supplementary Information: The products herewith comply with the requirements of the Low Voltage Directive 73/23/EEC and the EMC Directive 89/336/EEC and carry the CE-marking accordingly. | |
|  | |
| Santa Rosa, CA, USA | 17 April 2000 |
| Greg Pfeiffer/Quality Engineering Manager | |
| For further information, please contact your local Agilent Technologies sales office, agent or distributor. | |

About This Chapter

This chapter contains specifications and characteristics for the Agilent E4404B spectrum analyzer. The distinction between specifications and characteristics is described as follows.

- Specifications describe the performance of parameters covered by the product warranty. (The temperature range is 0 °C to 55 °C, unless otherwise noted.)
- Characteristics describe product performance that is useful in the application of the product, but is not covered by the product warranty.
- Typical performance describes additional product performance information that is not covered by the product warranty. It is performance beyond specification that 80% of the units exhibit with a 95% confidence level over the temperature range 20 to 30 °C. Typical performance does not include measurement uncertainty.
- Nominal values indicate the expected performance, or describe product performance that is useful in the application of the product, but is not covered by the product warranty.

The following conditions must be met for the analyzer to meet its specifications.

- o The analyzer is within the one year calibration cycle.
- o If **Auto Align All** is selected:
 - After 2 hours of storage within the operating temperature range.
 - 5 minutes after the analyzer is turned on with sweep times less than 4 seconds.
 - After the front-panel amplitude reference is connected to the INPUT, and **Align Now RF** has been run, after the analyzer is turned on. And, once every 24 hours, or if ambient temperature changes more than 30 °C¹.

1. 10 °C if Preamp (*Option IDS*) is active.

- o If **Auto Align Off** is selected:
 - When the analyzer is at a constant temperature, within the operating temperature range, for a minimum of 90 minutes.
 - After the analyzer is turned on for a minimum of 90 minutes, the front panel amplitude reference has been connected to the INPUT, and **Align Now All** has been run.
 - When **Align Now All** is run:
 - Every hour
 - If the ambient temperature changes more than 3 °C
 - If the 10 MHz reference changes
 - When **Align Now RF** is run (with the front-panel amplitude reference connected to the INPUT):
 - Every 24 hours
 - If the ambient temperature changes more than 30 °C¹
- o If **Auto Align All but RF** is selected:
 - When the analyzer is at a constant temperature, within the operating temperature range, for a minimum of 90 minutes.
 - After the analyzer is turned on for a minimum of 90 minutes, the front panel amplitude reference has been connected to the INPUT, and **Align Now RF** has been run.
 - When **Align Now RF** is run (with the front-panel amplitude reference connected to the INPUT):
 - Every hour
 - If the ambient temperature changes more than 3 °C

1. 10 °C if Preamp (*Option 1DS*) is active.

Frequency

| | Specifications | Supplemental Information |
|-------------------------------|--------------------|----------------------------------|
| Frequency Range | | |
| dc Coupled | 9 kHz to 6.7 GHz | 30 Hz to 6.7 GHz, characteristic |
| <i>(Option UKB)</i> | 100 Hz to 6.7 GHz | |
| ac Coupled | 100 kHz to 6.7 GHz | |
| Preamp On <i>(Option IDS)</i> | 1 MHz to 3.0 GHz | |

| | Specifications | Supplemental Information |
|----------------------------|------------------------------------|--|
| Frequency Reference | | |
| Aging Rate | $\pm 2 \times 10^{-6}/\text{year}$ | $\pm 1.0 \times 10^{-7}/\text{day}$, characteristic |
| Settability | $\pm 5 \times 10^{-7}$ | |
| Temperature Stability | $\pm 5 \times 10^{-6}$ | |

| | Specifications | Supplemental Information |
|---|------------------------------------|--|
| High Stability Frequency Reference <i>(Option IDS)</i> | | |
| Aging Rate | $\pm 1 \times 10^{-7}/\text{year}$ | $\pm 5 \times 10^{-10}/\text{day}$, 7-day average after being powered on for 7 days, characteristic |
| Settability | $\pm 1 \times 10^{-8}$ | |
| Temperature Stability | | |
| 20 to 30 °C | $\pm 1 \times 10^{-8}$ | |
| 0 to 55 °C | $\pm 5 \times 10^{-8}$ | |
| Warm-up (Internal frequency reference selected) | | |
| After 5 minutes | | $< \pm 1 \times 10^{-7}$ of final frequency, ^a characteristic |
| After 15 minutes | | $< \pm 1 \times 10^{-8}$ of final frequency, ^a characteristic |

a. Final frequency is defined as frequency 60 minutes after power-on with analyzer set to internal frequency reference.

| | Specifications | Supplemental Information |
|--|--|--------------------------|
| Frequency Readout Accuracy (Start, Stop, Center, Marker) | $\pm((\text{frequency indication} \times \text{frequency reference error}^a) + 0.5\% \text{ of span} + \frac{\text{span}}{\text{sweep points} - 1} + 15\% \text{ of RBW} + 10 \text{ Hz})$ | |

a. Frequency reference error = (aging rate \times period of time since adjustment + settability + temperature stability).

| | Specifications | Supplemental Information |
|---------------------------------|--|--------------------------|
| Marker Frequency Counter | | |
| Resolution | Selectable from 1 Hz to 100 kHz | |
| Accuracy ^a | $\pm(\text{marker frequency} \times \text{frequency reference error}^b + \text{counter resolution})$ | For RBW \geq 1 kHz |

a. Marker level to displayed noise level > 25 dB, RBW/ Span \geq 0.002, frequency offset = 0 Hz.

b. Frequency reference error = (aging rate \times period of time since adjustment + settability + temperature stability).

| | Specifications | Supplemental Information |
|-----------------------|---|--------------------------|
| Frequency Span | | |
| Range | 0 Hz (zero span), 100 Hz to 6.7 GHz | |
| Resolution | 2 Hz | |
| Accuracy ^a | $\pm(0.5\% \text{ of span} + 2 \times \frac{\text{span}}{\text{sweep points} - 1})$ | |

a. Applies to each sweep segment.

| | Specifications | Supplemental Information |
|---------------------------------------|-------------------------------------|---|
| Sweep Time | | |
| Range | | |
| Span > 0 Hz | 1 ms to 4000 s ^a | $\frac{\text{sweep points} - 1}{100 \text{ kHz}}$ to 4000 s |
| Span = 0 Hz | 10 μ s to 4000 s ^{a,b} | |
| Tracking Generator On (Option 1DN) | | 50 ms is the minimum sweep time |

Agilent E4404B Specifications and Characteristics
Frequency

| | Specifications | Supplemental Information |
|--|--|--|
| Fast Time-domain Sweep (<i>Option AYX</i>) (For Span = 0 Hz, RBW ≥ 1 kHz) | 50 ns to 4000 s ^{c,d} | $\frac{\text{sweep points} - 1}{20 \text{ MHz}}$ to 4000 s |
| DSP and fast ADC (<i>Option B7D</i>) (For Span = 0 Hz, RBW ≥ 1 kHz) | 25 ns to 4000 s ^e | $\frac{\text{sweep points} - 1}{40 \text{ MHz}}$ to 4000 s |
| Accuracy (Span = 0 Hz) | | |
| 10 μs to 4000 s ^{a,b} | ±1% | |
| (<i>Option AYX</i>) | ±1% | |
| 50 ns to 4000 s ^{c,d} | | |
| (<i>Option B7D</i>) | ±1% | |
| 25 ns to 4000 s ^e | | |
| Sweep Trigger ^{f,g} | Free Run, Single, Line, Video ^h , External, Delayed, Offset ⁱ | |
| (<i>Option 1D6</i>) | Add Gate | |
| (<i>Option B7B</i>) | Add TV | |
| (<i>Option B7E</i>) | Add Burst Carrier Trigger | |
| Delayed Trigger ^{g,j} | | |
| Range | 1 μs to 400 s | |
| Resolution | $\frac{\text{delay in seconds}}{65000}$ rounded up to nearest μs | |
| Accuracy | ±(500 ns + (0.01% of delay)) | |
| Offset Trigger ⁱ | | |
| Resolution | $\frac{\text{sweep time}}{\text{sweep points} - 1}$ | |
| Range | ±327 ms to ±12.3 ks | Where ST = sweep time and SP = sweep points $\frac{-32766 \times ST}{SP - 1}$ to $\frac{(32766 - SP) \times ST}{SP - 1}$ |

| | Specifications | Supplemental Information |
|---|---------------------|--|
| Fast Time-domain sweep (<i>Option AYX</i>) (For sweep times $\frac{\text{sweep points} - 1}{20 \text{ MHz}}$ to $\frac{\text{sweep points} - 1}{100 \text{ kHz}}$) | ±1.23 ms to ±245 ms | $\frac{-32766 \times ST}{SP - 1}$ to $\frac{(32766 - SP) \times ST}{SP - 1}$ |
| DSP and fast ADC (<i>Option B7D</i>) (For sweep times $\frac{\text{sweep points} - 1}{40 \text{ MHz}}$ to $\frac{\text{sweep points} - 1}{100 \text{ kHz}}$) | ±13 ms to ±5.15 s | $\frac{-524031 \times ST}{SP - 1}$ to $\frac{(524031 - SP) \times ST}{SP - 1}$ |

- a. For firmware revisions prior to A.04.00, 5 ms to 2000 s.
- b. For firmware revisions prior to A.05.00, 1 ms to 4000 s.
- c. For firmware revisions prior to A.04.00, 20 μs to 2000 s.
- d. For firmware revisions prior to A.05.00, 5 μs to 4000 s.
- e. For firmware revisions prior to A.05.00, 2.5 μs to 4000 s.
- f. Gate cannot be used simultaneously with delayed or TV trigger (*Option B7B*).
- g. Auto align is suspended in video, external, gate, and delayed trigger modes while waiting for a trigger event to occur.
- h. Unavailable when RBW ≤ 300 Hz (*Option IDR*).
- i. For firmware revision A.04.00 or later.
- j. Delayed trigger is available with line, external trigger, and TV trigger (*Option B7B*).

| | Specifications | Supplemental Information |
|--|--|--------------------------|
| Sweep (trace) Points Range Span > 0 Hz Span = 0 Hz | 101 to 8192 ^a 2 to 8192 ^{a,b} | |

- a. For firmware revisions prior to A.04.00, 401 points.
- b. For firmware revisions prior to A.05.00, 101 to 8192 points.

| | Specifications | Supplemental Information |
|--|---|--------------------------|
| Resolution Bandwidth (RBW) Range -3 dB bandwidth -6 dB bandwidth (EMI) | 1 kHz to 3 MHz, in 1-3-10 sequence, 5 MHz 9 kHz and 120 kHz | |

Agilent E4404B Specifications and Characteristics
Frequency

| | Specifications | Supplemental Information |
|--|---|---|
| <p><i>(Option IDR)</i></p> <p>-3 dB bandwidth</p> <p>-6 dB bandwidth (EMI)</p> <p>Accuracy</p> <p>1 kHz to 3 MHz RBW</p> <p>5 MHz RBW</p> <p>Shape</p> <p>1 kHz to 5 MHz RBW</p> <p>10 Hz to 300 Hz RBW <i>(Option IDR)</i></p> <p>Selectivity (60 dB/3 dB bandwidth ratio)</p> <p>1 kHz to 5 MHz RBW</p> <p>10 Hz to 300 Hz RBW <i>(Option IDR)</i></p> | <p>Adds 10, 30, 100, 300 Hz</p> <p>Add 200 Hz</p> <p>±15%</p> <p>±30%</p> | <p>Only available in spans ≤ 5 MHz, sweep times $\geq \frac{\text{sweep points} - 1}{100 \text{ kHz}}$, and not usable with tracking generator on. <i>(Option IDN)</i></p> <p>Synchronously tuned four poles, approximately Gaussian shape</p> <p>Digital, approximately Gaussian shape</p> <p><15:1, characteristic</p> <p><5:1, characteristic</p> |

| | Specifications | Supplemental Information |
|--|--|--|
| <p>Video Bandwidth (VBW) (-3 dB)</p> <p>Range</p> <p><i>(Option IDR)</i></p> <p>Accuracy</p> <p>Shape</p> | <p>30 Hz to 1 MHz in 1-3-10 sequence</p> <p>Adds 1, 3, 10 Hz for RBW's <1 kHz</p> | <p>3 MHz, characteristic</p> <p>±30%, characteristic</p> <p>Post detection, single pole low-pass filter used to average displayed noise</p> <p>Video bandwidths below 30 Hz are digital bandwidths with anti-aliasing filtering.</p> |

| | Specifications | Supplemental Information |
|--|-----------------------------|---|
| Stability | | |
| Noise Sidebands (Offset from CW signal with 1 kHz RBW, 30 Hz VBW and sample detector) | | |
| ≥ 1 kHz (<i>Option 1DR, 1D5</i>) | | ≤ -78 dBc/Hz, typical |
| ≥ 10 kHz | ≤ -90 dBc/Hz | ≤ -94 dBc/Hz, typical |
| ≥ 20 kHz | ≤ -100 dBc/Hz | ≤ -105 dBc/Hz, typical |
| ≥ 30 kHz | ≤ -106 dBc/Hz | ≤ -112 dBc/Hz, typical |
| ≥ 100 kHz | ≤ -119 dBc/Hz | ≤ -122 dBc/Hz, typical |
| ≥ 1 MHz | ≤ -125 dBc/Hz | ≤ -127 dBc/Hz, typical |
| ≥ 5 MHz | ≤ -127 dBc/Hz | ≤ -129 dBc/Hz, typical |
| ≥ 10 MHz | ≤ -131 dBc/Hz | ≤ -136 dBc/Hz, typical |
| <i>(Option 120)</i> | | |
| ≥ 1 MHz | ≤ -133 dBc/Hz | ≤ -136 dBc/Hz, typical |
| ≥ 5 MHz | ≤ -135 dBc/Hz | ≤ -139 dBc/Hz, typical |
| ≥ 10 MHz | ≤ -137 dBc/Hz | ≤ -141 dBc/Hz, typical |
| Residual FM | | |
| 1 kHz RBW, 1 kHz VBW <i>(Option 1D5)</i> | ≤ 150 Hz p-p in 100 ms | |
| 10 Hz RBW, 10 Hz VBW <i>(Option 1DR and 1D5)</i> | ≤ 100 Hz p-p in 100 ms | |
| 10 Hz RBW, 10 Hz VBW <i>(Option 1DR)</i> | ≤ 2 Hz p-p in 20 ms | ≤ 10 Hz p-p in 20 ms, characteristic |
| System-Related Sidebands, offset from CW signal | | |
| ≥ 30 kHz | ≤ -65 dBc | |
| Line-Related Sidebands, offset from CW signal (<i>Option 1DR</i>) | | |
| < 300 Hz | | ≤ -50 dBc, characteristic |
| > 300 Hz to 30 kHz | | ≤ -55 dBc, characteristic |

Noise Sidebands Normalized to 1 Hz Versus Offset from Carrier

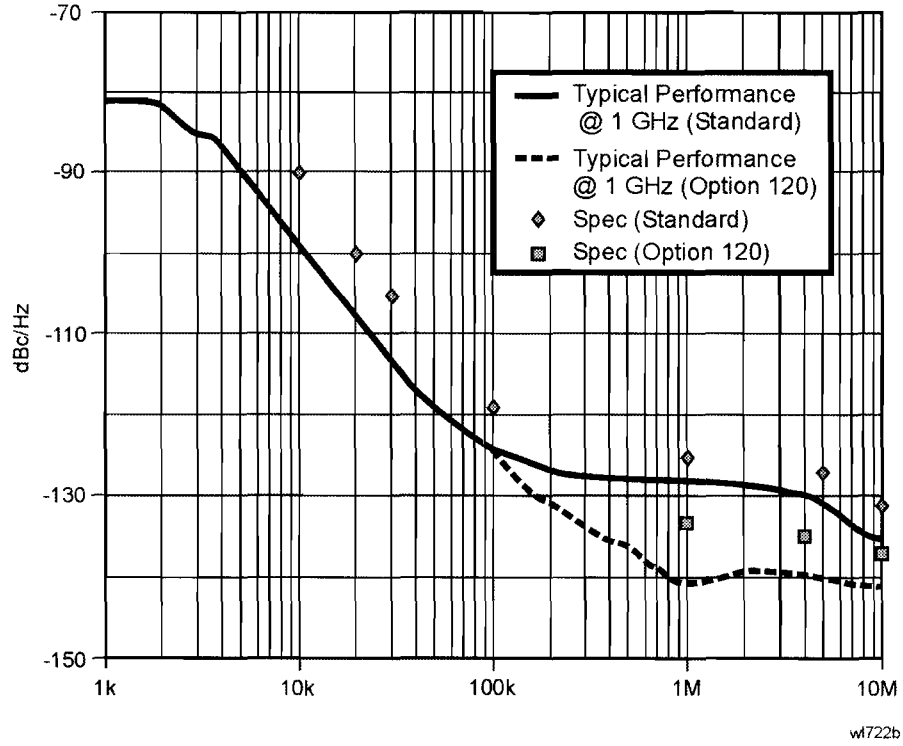

Amplitude

Amplitude specifications do not apply for the negative peak detector mode.

| | Specifications | Supplemental Information |
|--------------------------|---|---|
| Measurement Range | Displayed Average Noise Level to Maximum Safe Input Level | |
| Input Attenuator Range | 0 to 65 dB, in 5 dB steps | 0 to 75 dB, in 5 dB steps, characteristic |

| | Specifications | Supplemental Information |
|--|-----------------|--------------------------|
| Maximum Safe Input Level | | |
| Average Continuous Power (Input attenuator setting ≥ 5 dB) | +30 dBm (1 W) | |
| Peak Pulse Power (for < 10 μ sec pulse width, $< 1\%$ duty cycle, and input attenuation ≥ 30 dB) | +50 dBm (100 W) | |
| dc | | |
| dc Coupled | 0 Vdc | |
| ac Coupled | 50 Vdc | |

| | Specifications | Supplemental Information |
|---|----------------|--------------------------|
| 1 dB Gain Compression | | |
| Total power at input mixer ^{a,b} | | |
| 50 MHz to 3.0 GHz | 0 dBm | |
| 3.0 GHz to 6.7 GHz | 0 dBm | |
| Preamp On (<i>Option 1DS</i>) | | |
| Total power at the preamp ^c | | -20 dBm, characteristic |

- a. Mixer power level (dBm) = input power (dBm) – input attenuation (dB).
- b. For resolution bandwidths 1 kHz to 30 kHz, the maximum input signal amplitude must be \leq reference level +10 dB.
- c. Total power at the preamp (dBm) = total power at the input (dBm) – input attenuation (dB).

| | Specifications | | Supplemental Information | |
|--|------------------------|---------------------------------------|-------------------------------------|---|
| | | | | |
| Displayed Average Noise Level (Input terminated, 0 dB attenuation, sample detector, Reference Level = -70 dBm) | | | | |
| | 1 kHz RBW 30 Hz VBW | 10 Hz RBW 1 Hz VBW (Option 1DR) | 1 kHz RBW 30 Hz VBW (typical) | 10 Hz RBW 1 Hz VBW (Option 1DR) (typical) |
| 30 Hz to 9 kHz (Option UKB) | | | | ≤ -93 dBm |
| 9 kHz to 100 kHz | | | | ≤ -109 dBm |
| 100 kHz to 1 MHz | | | | ≤ -135 dBm |
| 1 MHz to 10 MHz | | | ≤ -117 dBm | ≤ -137 dBm |
| 1 MHz to 10 MHz (Option 120) | | | ≤ -120 dBm | ≤ -139 dBm |
| 10 MHz to 1.0 GHz | ≤ -116 dBm | ≤ -135 dBm | ≤ -119 dBm | ≤ -139 dBm |
| 1.0 GHz to 2.0 GHz | ≤ -116 dBm | ≤ -135 dBm | ≤ -120 dBm | ≤ -140 dBm |
| 2.0 GHz to 3.0 GHz | ≤ -112 dBm | ≤ -131 dBm | ≤ -118 dBm | ≤ -138 dBm |
| 3.0 GHz to 6.0 GHz | ≤ -112 dBm | ≤ -131 dBm | ≤ -118 dBm | ≤ -138 dBm |
| 6.0 GHz to 6.7 GHz | ≤ -111 dBm | ≤ -130 dBm | ≤ -117 dBm | ≤ -137 dBm |
| Preamp On (Option 1DS) | 1 kHz RBW 30 Hz VBW | 10 Hz RBW 1 Hz VBW (Option 1DR) | 1 kHz RBW 30 Hz VBW (typical) | 10 kHz RBW 1 Hz VBW (Option 1DR) (typical) |
| 0 to 55 °C | | | | |
| 10 MHz to 1.0 GHz | ≤ -131 dBm | ≤ -150 dBm | | |
| 1.0 GHz to 2.0 GHz | ≤ -131 dBm | ≤ -150 dBm | | |
| 2.0 GHz to 3.0 GHz | ≤ -127 dBm | ≤ -146 dBm | | |
| 20 to 30 °C | | | | |
| 1 MHz to 10 MHz | | | ≤ -135 dBm | ≤ -155 dBm |
| 10 MHz to 1.0 GHz | ≤ -132 dBm | ≤ -151 dBm | ≤ -137 dBm | ≤ -157 dBm |
| 1.0 GHz to 2.0 GHz | ≤ -132 dBm | ≤ -151 dBm | ≤ -135 dBm | ≤ -155 dBm |
| 2.0 GHz to 3.0 GHz | ≤ -130 dBm | ≤ -149 dBm | ≤ -132 dBm | ≤ -152 dBm |

| | Specifications | Supplemental Information |
|---|---|--------------------------|
| Display Range | | |
| Log Scale | Ten divisions displayed; 0.1, 0.2, 0.5 dB/division and 1 to 20 dB/division in 1 dB steps | |
| RBW \geq 1 kHz | Calibrated 0 to -85 dB from Reference Level | |
| RBW \leq 300 Hz (<i>Option IDR</i>) | Calibrated 0 to -120 dB ^a from Reference Level | |
| Linear Scale | Ten divisions | |
| Scale Units | dBm, dBmV, dB μ V, dB μ A, A, V, and W | |
| (<i>Option BAA, 106</i>) | Add Hz | |

- a. 0 to -70 dB range when span = 0 Hz, or when IF Gain fixed:
(:DISPlay:WINDow:TRACe:Y[:SCALE]:LOG:RANGE:AUTO OFF).

| | Specifications | Supplemental Information |
|---|--|--------------------------|
| Marker Readout Resolution | | |
| Log scale | | |
| RBW \geq 1 kHz | | |
| 0 to -85 dB from ref level | 0.04 dB | |
| RBW \leq 300 Hz (<i>Option IDR</i>) | | |
| 0 to -120 dB from ref level | 0.04 dB | |
| Linear scale | 0.01% of Reference Level | |
| Fast Sweep Times for Zero Span | | |
| (<i>Option AYX</i>) | | |
| For sweep times | | |
| $\frac{\text{sweep points} - 1}{20 \text{ MHz}}$ to | | |
| $\frac{\text{sweep points} - 1}{100 \text{ kHz}}$ | | |
| Log | | |
| 0 to -85 dB from ref level | 0.3 dB | |
| Linear | 0.3% of Reference Level for linear scale | |

| | Specifications | Supplemental Information |
|--|---|--------------------------|
| <p><i>(Option B7D)</i> For sweep times $\frac{\text{sweep points} - 1}{40 \text{ MHz}}$ to $\frac{\text{sweep points} - 1}{100 \text{ kHz}}$</p> <p>Log 0 to -85 dB from ref level</p> <p>Linear</p> | <p>0.2 dB</p> <p>0.2% of Reference Level for linear scale</p> | |

| | Specifications | Supplemental Information |
|---|--|--|
| <p>Frequency Response</p> <p>50 Ω, Absolute^a/Relative</p> <p>10 dB attenuation (dc coupled)</p> <p>9 kHz to 3.0 GHz</p> <p>20 to 30 °C</p> <p>0 to 55 °C</p> <p>(ac coupled)</p> <p>100 kHz to 3.0 GHz</p> <p>20 to 30 °C</p> <p>0 to 55 °C</p> <p>800 MHz to 1.0 GHz^b</p> <p>20 to 30 °C</p> <p>0 to 55 °C</p> <p>1.7 GHz to 2.0 GHz</p> <p>20 to 30 °C</p> <p>0 to 55 °C</p> | <p>± 0.46 dB</p> <p>± 0.76 dB</p> <p>± 0.50 dB</p> <p>± 1.0 dB</p> <p>± 0.50 dB</p> <p>± 1.0 dB</p> <p>± 0.50 dB</p> <p>± 1.0 dB</p> | <p>± 0.14 dB, typical</p> <p>± 0.10 dB, typical</p> <p>± 0.08 dB, typical</p> |

| | Specifications | Supplemental Information |
|---|----------------|--------------------------|
| <i>(Option UKB)</i> | | |
| 100 Hz to 3.0 GHz (dc coupled) | | |
| 20 to 30 °C | ±0.50 dB | |
| 0 to 55 °C | ±1.00 dB | |
| 30 Hz to 3.0 GHz (dc coupled) | | |
| 20 to 30 °C | | ±0.5 dB, characteristic |
| 0 to 55 °C | | ±1.0 dB, characteristic |
| Absolute ^a /Relative, Preamp On <i>(Option IDS)</i> | | |
| 0 dB attenuation | | |
| 1 MHz to 3.0 GHz | | |
| 20 to 30 °C | ±1.5 dB | |
| 0 to 55 °C | ±2.0 dB | |
| 800 MHz to 1.0 GHz | | |
| 20 to 30 °C | ±1.5 dB | ±0.35 dB, typical |
| 0 to 55 °C | ±2.0 dB | |
| 1.7 GHz to 2.0 GHz | | |
| 20 to 30 °C | ±1.5 dB | ±0.26 dB, typical |
| 0 to 55 °C | ±2.0 dB | |
| Preselector centered for frequency >3.0 GHz | | |
| 10 dB attenuation | | |
| 3.0 GHz to 6.7 GHz (ac or dc coupled) | | |
| Absolute ^a | | |
| 20 to 30 °C | ±1.5 dB | |
| 0 to 55 °C | ±2.5 dB | |
| Relative | | |
| 20 to 30 °C | ±1.3 dB | |
| 0 to 55 °C | ±1.5 dB | |

a. Absolute frequency response values are referenced to the amplitude at 50 MHz.

b. This specification applies only to analyzers with serial numbers \geq US39440498.

| | Specifications | Supplemental Information |
|--|---------------------------------------|--------------------------|
| Input Attenuation Switching Uncertainty at 50 MHz | | |
| Attenuator Setting | | |
| 0 dB to 5 dB | ±0.3 dB | |
| 10 dB | Reference | |
| 15 dB | ±0.3 dB | |
| 20 to 65 dB attenuation | ±(0.1 dB + 0.01 × Attenuator Setting) | |

| Attenuation Accuracy Relative to the 10 dB Attenuator Setting, Characteristic | | |
|--|------------------------|--------------------|
| | Frequency Range | |
| Attenuation | dc–3.0 GHz | 3.0–6.7 GHz |
| 0 dB | ±0.3 dB | ±0.5 dB |
| 5 dB | ±0.3 dB | ±0.5 |
| 10 dB | Reference | Reference |
| 15 dB | ±0.4 dB | ±0.5 dB |
| 20 dB | ±0.4 dB | ±0.5 dB |
| 25 dB | ±0.5 dB | ±0.6 dB |
| 30 dB | ±0.5 dB | ±0.6 dB |
| 35 dB | ±0.6 dB | ±0.7 dB |
| 40 dB | ±0.6 dB | ±0.7 dB |
| 45 dB | ±0.7 dB | ±1.0 dB |
| 50 dB | ±0.7 dB | ±1.0 dB |
| 55 dB | ±0.9 dB | ±1.1 dB |
| 60 dB | ±0.9 dB | ±1.1 dB |
| 65 dB | ±1.0 dB | ±1.6 dB |

| | Specifications | Supplemental Information |
|----------------------------|----------------|---|
| Preamp (Option 1DS) | | Refer also to Displayed Average Noise Level specification |
| Gain | | +20 dB, nominal ^a |
| Noise figure | | 5 dB, characteristic |

a. Amplifier is between the input attenuator and the input mixer.

| | Specifications | Supplemental Information |
|---|---|--------------------------|
| Absolute Amplitude Accuracy | | |
| At reference settings ^a | ±0.34 dB | ±0.13 dB, typical |
| Preamp On ^b (Option 1DS) | ±0.37 dB | ±0.14 dB, typical |
| Overall Amplitude Accuracy^c | | |
| 20 to 30 °C | ± (0.54 dB + Absolute Frequency Response) | |

a. Settings are: reference level -20 dBm; input attenuation 10 dB; dc coupled; center frequency 50 MHz; RBW 1 kHz; VBW 1 kHz; scale linear or log; span 2 kHz; sweep time coupled, sample detector, signal at reference level.

b. Settings are: reference level -30 dBm; input attenuation 0 dB; dc coupled; center frequency 50 MHz; RBW 1 kHz; VBW 1 kHz; scale linear or log; span 2 kHz; sweep time coupled, signal at reference level.

c. For reference level 0 to -50 dBm; input attenuation 10 dB; dc coupled; RBW 1 kHz; VBW 1 kHz; scale log, log range 0 to -50 dB from reference level; sweep time coupled; signal input 0 to -50 dBm; span ≤20 kHz.

| | Specifications | Supplemental Information | |
|---|----------------|--------------------------|----------------|
| RF Input VSWR (at tuned frequency) | | characteristic | characteristic |
| Attenuator setting 0 dB | | (dc coupled) | (ac coupled) |
| 9 kHz to 100 kHz | | ≤3.0:1 | |
| 100 kHz to 6.7 GHz | | ≤3.0:1 | ≤3.0:1 |
| 100 Hz to 100 kHz (Option UKB) | | ≤1.1:1 | |
| Attenuator setting 5 dB | | (dc coupled) | (ac coupled) |
| 9 kHz to 100 kHz | | ≤2.0:1 | |
| 100 kHz to 300 kHz | | ≤1.4:1 | ≤2.3:1 |
| 300 kHz to 1.0 MHz | | ≤1.4:1 | ≤1.6:1 |
| 1.0 MHz to 3.0 GHz | | ≤1.4:1 | ≤1.4:1 |
| 3.0 GHz to 6.7 GHz | | ≤1.4:1 | ≤1.7:1 |

Agilent E4404B Specifications and Characteristics
Amplitude

| | Specifications | Supplemental Information | |
|-----------------------------------|----------------|--------------------------|--------------|
| 100 Hz to 100 kHz (Option UKB) | | ≤1.1:1 | |
| Attenuator setting 10 to 65 dB | | (dc coupled) | (ac coupled) |
| 9 kHz to 100 kHz | | ≤2.0:1 | |
| 100 kHz to 300 kHz | | ≤1.3:1 | ≤2.1:1 |
| 300 kHz to 1.0 MHz | | ≤1.3:1 | ≤1.5:1 |
| 1.0 MHz to 3.0 GHz | | ≤1.3:1 | ≤1.3:1 |
| 3.0 GHz to 6.7 GHz | | ≤1.3:1 | ≤1.5:1 |
| 100 Hz to 100 kHz (Option UKB) | | ≤1.1:1 | |

| | Specifications | Supplemental Information |
|-----------------------------------|----------------|--------------------------|
| Auto Alignment^a | | |
| Sweep-to-sweep variation | | ±0.1 dB, characteristic |

a. Set **Auto Align** to **Off** and use **Align Now, All** to eliminate this variation.

| | Specifications | Supplemental Information |
|--|----------------|--------------------------|
| Resolution Bandwidth Switching Uncertainty (at Reference Level) | | |
| 1 kHz RBW | Reference | |
| 3 kHz to 3 MHz RBW | ±0.3 dB | |
| 5 MHz RBW | ±0.6 dB | |
| 10 Hz to 300 Hz RBW (Option IDR) | ±0.3 dB | |

| | Specifications | Supplemental Information |
|------------------------|--|--------------------------|
| Reference Level | | |
| Range | -149.9 dBm to maximum mixer level + attenuator setting | |
| Resolution | | |
| Log Scale | ±0.1 dB | |
| Linear Scale | ±0.12% of Reference Level | |

| | Specifications | Supplemental Information |
|--|----------------|--------------------------|
| Accuracy (at a fixed frequency, a fixed attenuator, and referenced to -30 dBm (-10 dBm, Preamp On (Option 1DS))) | | |
| Reference Level (dBm) – input attenuator setting (dB) + preamp gain (dB) | | |
| -10 dBm to > -60 dBm | ±0.3 dB | |
| -60 dBm to > -85 dBm | ±0.5 dB | |
| -85 dBm to -90 dBm | ±0.7 dB | |

| | Specifications | Supplemental Information |
|--|-----------------------------|--------------------------|
| Display Scale Switching Uncertainty | | |
| Switching between Linear and Log | ±0.15 dB at reference level | |
| Log Scale Switching | No error | |

| | Specifications | Supplemental Information |
|-------------------------------|----------------|--------------------------|
| Display Scale Fidelity | | |
| Log Maximum Cumulative | | |
| RBW ≥ 1 kHz | | |
| dB Below Reference Level | | |
| 0 dB Reference | 0 dB | |
| > 0 to 10 dB | ±0.22 dB | ±0.08 dB, typical |
| > 10 to 20 dB | ±0.24 dB | ±0.09 dB, typical |
| > 20 to 30 dB | ±0.26 dB | ±0.10 dB, typical |
| > 30 to 40 dB | ±0.40 dB | ±0.23 dB, typical |
| > 40 to 50 dB | ±0.57 dB | ±0.35 dB, typical |
| > 50 to 60 dB | ±0.57 dB | ±0.35 dB, typical |
| > 60 to 70 dB | ±0.66 dB | ±0.39 dB, typical |
| >70 to 80 dB | ±0.66 dB | ±0.46 dB, typical |
| >80 to 85 dB | ±1.15 dB | ±0.79 dB, typical |

Agilent E4404B Specifications and Characteristics
Amplitude

| | Specifications | Supplemental Information |
|--|---|--|
| RBW \leq 300 Hz (Option IDR) Span $>$ 0 Hz Auto range On 0 to 98 dB below reference level $>$ 98 to 120 dB below reference level Auto range Off 0 to 60 dB below reference level $>$ 60 to 70 dB below reference level Span = 0 Hz ^a 0 to 60 dB below reference level $>$ 60 to 70 dB below reference level Log Incremental Accuracy 0 to 80 dB ^b below reference level Linear Accuracy | $\pm(0.3 \text{ dB} + 0.01 \times \text{dB from reference level})$ $\pm(0.3 \text{ dB} + 0.015 \times \text{dB from reference level})$ $\pm 1.5 \text{ dB}$ $\pm(0.3 \text{ dB} + 0.015 \times \text{dB from reference level})$ $\pm 1.5 \text{ dB}$ $\pm 0.4 \text{ dB/4 dB}$ $\pm 2\%$ of Reference Level | $\pm 2.0 \text{ dB, characteristic}$ |

- a. The SCPI command for auto range off is:
 (:DISPlay:WINDow:TRACe:Y[:SCALe]:LOG:RANGE:AUTO OFF)
- b. 0 to -50 dB for RBWs $\leq 300 \text{ Hz}$ and span = 0 Hz, or when auto ranging is off.

| | Specifications | Supplemental Information |
|--|--|---|
| Spurious Responses Second Harmonic Distortion Input Signal 10 MHz to 500 MHz 500 MHz to 1.5 GHz 1.5 GHz to 2.0 GHz | $< -65 \text{ dBc}$ for -30 dBm signal at input mixer ^a $< -75 \text{ dBc}$ for -30 dBm signal at input mixer ^a $< -85 \text{ dBc}$ for -10 dBm signal at input mixer ^a | $+35 \text{ dBm SHI}$ (second harmonic intercept) $+45 \text{ dBm SHI}$ $+75 \text{ dBm SHI}$ |

| | Specifications | Supplemental Information |
|--|--|--|
| 2.0 GHz to 3.35 GHz | < -100 dBc ^b for -10 dBm signal at input mixer ^a | +90 dBm SHI |
| Preamp On (<i>Option 1DS</i>) 10 MHz to 1.5 GHz | | -5 dBm SHI, characteristic |
| Third Order Intermodulation Distortion | | |
| 10 MHz to 100 MHz | | +7 dBm TOI (third order intercept), characteristic |
| 100 MHz to 3 GHz | < -85 dBc for two -30 dBm signals at input mixer ^a and >50 kHz separation | +12.5 dBm TOI +16 dBm TOI, typical |
| 3.0 GHz to 6.7 GHz | < -82 dBc for two -30 dBm signals at input mixer ^a and >50 kHz separation | +11 dBm TOI +18 dBm TOI, typical |
| Preamp On (<i>Option 1DS</i>) 10 MHz to 3 GHz | | -16 dBm TOI, characteristic |
| Other Input Related Spurious | | |
| Inband Responses | | |
| >30 kHz offset | < -65 dBc for -20 dBm signal at input mixer ^a | |
| Out-of-band Responses | < -80 dBc for -10 dBm signal at input mixer ^a | |

a. Mixer power level (dBm) = input power (dBm) – input attenuation (dB).

b. or signal below displayed average noise level.

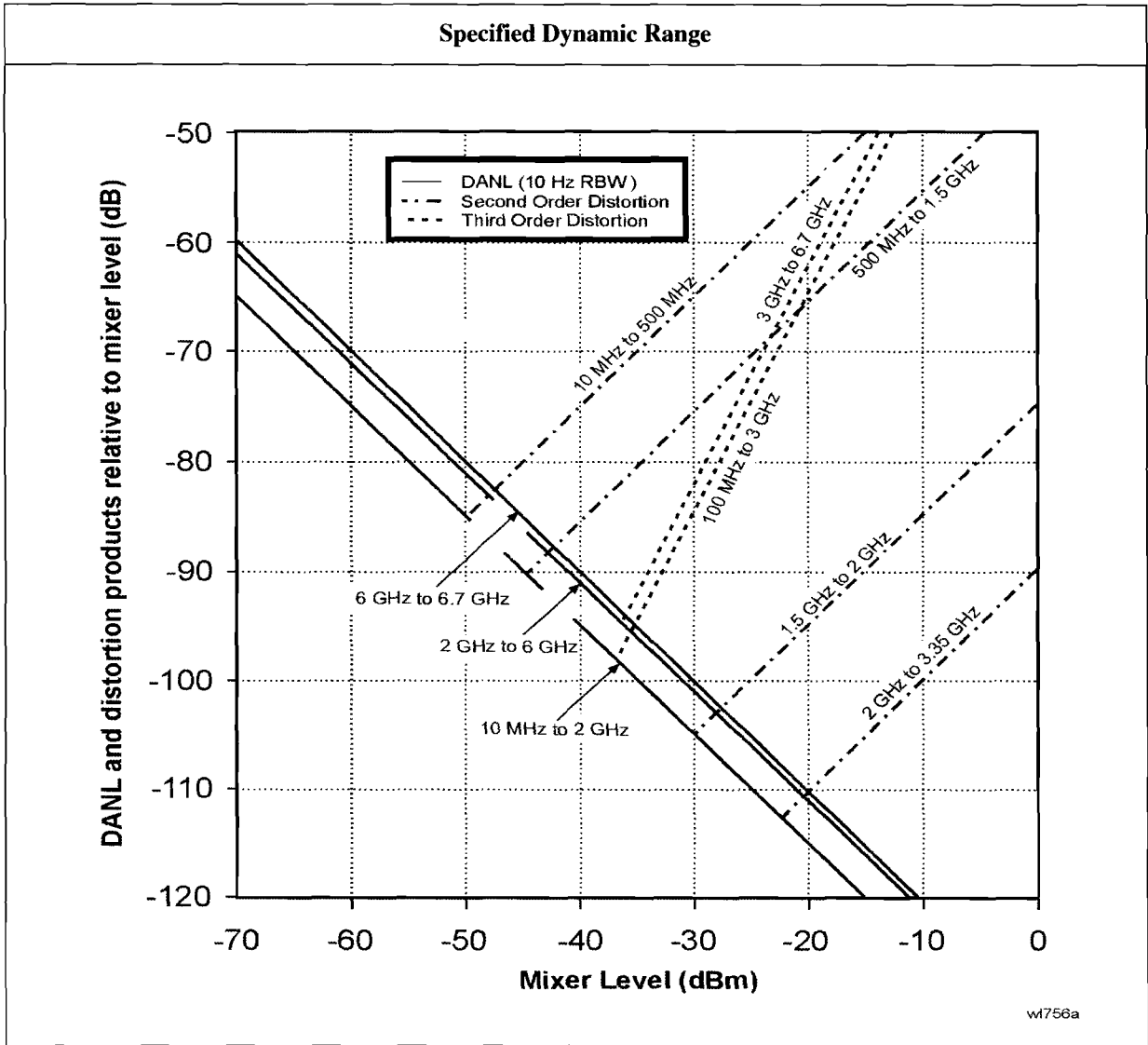

| | Specifications | Supplemental Information |
|---|-----------------------|---------------------------------|
| Residual Responses (Input terminated and 0 dB attenuation) 150 kHz to 6.7 GHz | < -90 dBm | |

Options

Time Gated Spectrum Analysis (Option 1D6)

| | Specifications | Supplemental Information |
|---|---|---|
| Gate Delay | | |
| Range | 1 μ s to 400 s | |
| Accuracy | $\pm(500 \text{ ns} + (0.01\% \times (\text{maximum of gate delay or length})))$ | From gate trigger input to positive edge of gate output |
| Gate Length | | |
| Range | 1 μ s to 400 s | |
| Accuracy | $\pm(500 \text{ ns} + (0.01\% \times (\text{maximum of gate delay or length})))$ | From positive edge to negative edge of gate output |
| Resolution | $((\text{maximum of gate delay or length in seconds})/65000)$ rounded up to nearest μ s | Dependent on the greater of gate delay or gate length |
| Additional Amplitude Error^a | | |
| Log Scale | $\pm 0.2 \text{ dB}$ | |
| Linear Scale | $\pm 0.1\%$ of reference level | |

a. While in gate mode.

Tracking Generator (Option 1DN)

The spectrum analyzer/tracking generator combination will meet its specification after a cable (8120-5148) and adapter are connected between RF OUT and INPUT and **Align Now, TG** has been run.

| | Specifications | Supplemental Information |
|----------------|----------------|--------------------------|
| Warm-up | 5 minutes | |

| | Specifications | Supplemental Information |
|-------------------------------|------------------|--------------------------|
| Output Frequency Range | 9 kHz to 3.0 GHz | |

| | Specifications | Supplemental Information |
|------------------------------|----------------|---|
| Minimum Resolution BW | 1 kHz | Not usable with resolution bandwidths ≤ 300 Hz (Option 1DR) |

| | Specifications | Supplemental Information |
|---|--------------------------|--------------------------|
| Output Power Level | | |
| Range | -2 to -66 dBm | |
| Resolution | 0.1 dB | |
| Absolute Accuracy (at 50 MHz with coupled source attenuator, referenced to -20 dBm) | ± 0.75 dB | |
| Vernier | | |
| Range | 8 dB | |
| Accuracy (with coupled source attenuator, 50 MHz, -20 dBm) | | |
| Incremental | ± 0.2 dB/dB | |
| Cumulative | ± 0.5 dB, total | |
| Output Attenuator Range | 0 to 56 dB in 8 dB steps | |

| | Specifications | Supplemental Information |
|-----------------------------------|----------------|---------------------------------------|
| Maximum Safe Reverse Level | | +30 dBm (1 W), 50 Vdc, characteristic |

| | Specifications | Supplemental Information |
|---------------------------|---|--------------------------|
| Output Power Sweep | | |
| Range | (-10 to -2 dBm) – (Source Attenuator Setting) | |
| Resolution | 0.1 dB | |
| Accuracy (zero span) | <1 dB peak-to-peak | |

| | Specifications | Supplemental Information |
|-------------------------------|----------------|--------------------------|
| Output Flatness | | |
| Referenced to 50 MHz, -20 dBm | | |
| 9 kHz to 10 MHz | ± 3 dB | |
| 10 MHz to 3 GHz | ± 2 dB | |

| | Specifications | Supplemental Information |
|---|----------------|--------------------------|
| Spurious Outputs | | |
| (-2 dBm output) | | |
| Harmonic Spurs | | |
| TG Output 9 kHz to 20 kHz | ≤ -15 dBc | |
| TG Output 20 kHz to 3 GHz | ≤ -25 dBc | |
| Non-harmonic Spurs | | |
| TG Output 9 kHz to 2 GHz | ≤ -27 dBc | |
| TG Output 2 GHz to 3 GHz | ≤ -23 dBc | |
| LO Feedthrough | | |
| LO Frequency 3.921409 GHz to 6.9214 GHz | ≤ -16 dBm | |

| | Specifications | Supplemental Information |
|----------------------|---|--------------------------|
| Dynamic Range | Maximum Output Power Level – Displayed Average Noise Level | |

Agilent E4404B Specifications and Characteristics
Options

| | Specifications | Supplemental Information |
|------------------------|----------------|--|
| Output Tracking | | |
| Drift | | 1.5 kHz/5 minute, characteristic |
| Swept Tracking Error | | Usable in 1 kHz RBW after 5 minutes of warm-up |

| | Specifications | Supplemental Information |
|-------------------------------|----------------|----------------------------|
| RF Power-Off Residuals | | |
| 9 kHz to 3 GHz | | < -120 dBm, characteristic |

| | Specifications | Supplemental Information |
|--|----------------|--------------------------|
| Output Attenuator Repeatability | | |
| 9 kHz to 300 MHz | | ±0.1 dB, characteristic |
| 300 MHz to 2 GHz | | ±0.2 dB, characteristic |
| 2 GHz to 3 GHz | | ±0.3 dB, characteristic |

| | Specifications | Supplemental Information |
|--------------------|----------------|--------------------------|
| Output VSWR | | |
| 0 dB attenuation | | <2.0:1, characteristic |
| ≥ 8 dB attenuation | | <1.5:1, characteristic |

| | Specifications | Supplemental Information |
|-----------------------------------|----------------|--------------------------|
| Output Attenuator Accuracy | | |
| 0 dB | Reference | ±0.5 dB, characteristic |
| 8 dB | | ±0.5 dB, characteristic |
| 16 dB | | ±0.5 dB, characteristic |
| 24 dB | | ±0.5 dB, characteristic |
| 32 dB | | ±0.6 dB, characteristic |
| 40 dB | | ±0.8 dB, characteristic |
| 48 dB | | ±1.0 dB, characteristic |
| 56 dB | | ±1.1 dB, characteristic |

Tracking Generator Output Accuracy

Relative Accuracy (Referred to -20 dBm) =
Output Attenuator Accuracy + Vernier Accuracy + Output Flatness

Absolute Accuracy =
Relative Accuracy (Referred to -20 dBm) + Absolute Accuracy at 50 MHz

Bluetooth FM Demodulation (Option 106)

The FM demodulation characteristics will apply after an Align Now, FM Demod has been run.

| | Specifications | Supplemental Information |
|-----------------------------|----------------|---|
| Optimum Input Level | | $\geq (-40 \text{ dBm} + \text{attenuator setting} - \text{preamp gain})$ and within 10 dB of the reference level |
| FM Deviation | | |
| Range | | $\pm 200 \text{ kHz}$, nominal |
| Resolution | | Provides 400 Hz display annotation resolution, nominal |
| Accuracy ^a | | |
| Input level = -30 dBm | | $\pm 10 \text{ kHz}$, typical |
| Reference level = -30 dBm | | $\pm 4 \text{ kHz}$ with video averaging On and averages ≥ 25 |
| FM Rate = 500 kHz sine | | |
| VBW = 3 MHz, | | |
| RBW = 5 MHz, | | |
| FM Deviation = 140 kHz | | |
| Offset Error ^a | | $\pm 1 \text{ kHz}$, typical |
| FM Bandwidth (-3 dB) | | 1.2 MHz, nominal |

a. In time domain sweeps (span = 0 Hz).

Bluetooth Measurements Personality (Option 228)

The demodulation related nominals will apply after an Align Now, FM Demod has been run.

| | Specifications | Supplemental Information |
|--------------------------------|--------------------|--------------------------|
| In-Band Frequency Range | | |
| Bluetooth (ISM) Band | 2400 to 2483.5 MHz | |

| | Specifications | Supplemental Information |
|--|---|---|
| Output Power (Option AYX or B7D) | | |
| Range at RF Input | 30 to -40 dBm | |
| (Option IDS) | 30 to -60 dBm | |
| Absolute Amplitude Accuracy | | Appendix , “Absolute Amplitude Accuracy,” on page 123 |
| Average type | Video, Power | |
| Average mode | Exponential, Repeat | |
| Trigger source | Video, RF burst ^a , External, Free Run | |
| Burst synch | RF Amplitude, Preamble ^b , None | |

a. Requires Option B7E

b. Requires Option 106 Bluetooth FM demodulation.

| | Specifications | Supplemental Information |
|--|---------------------------------|--|
| Modulation Characteristics^a (Option 106 and AYX or B7D) | | |
| Range at RF Input | 30 to -40 dBm | |
| (Option IDS) | 30 to -60 dBm | |
| FM Deviation | | |
| Range | | ±200 kHz, nominal |
| Accuracy | | ±4 kHz, nominal (25 measurement averages, signal level > -30 dBm) |
| Payload data | 11110000, 10101010, auto-detect | |
| Average mode | Exponential, Repeat | |

Agilent E4404B Specifications and Characteristics
Options

| | Specifications | Supplemental Information |
|----------------|---|--------------------------|
| Trigger source | Video, RF burst ^b , External, Free Run | |
| Burst synch | RF Amplitude, Preamble ^c , None | |
| Limits | $\Delta f_2/\Delta f_1$ lower, Δf_1 max lower/upper Δf_2 | |

- a. The DUT must have frequency hopping disabled.
- b. Requires Option B7E
- c. Requires Option 106 Bluetooth FM demodulation.

| | Specifications | Supplemental Information |
|--|---|---|
| Carrier Frequency Drift ^a (Option 106 and AYX or B7D) | | |
| Range at RF Input | 30 to -40 dBm | |
| (Option 1DS) | 30 to -60 dBm | |
| Measurement range | | ± 100 kHz, nominal |
| Measurement accuracy | | ± 4 kHz, nominal (25 measurement averages, signal level > -30 dBm) |
| Average mode | Exponential, Repeat | |
| Trigger source | Video, RF burst ^b , External, Free Run | |
| Burst synch | Preamble ^c , None | |

- a. The DUT must have frequency hopping disabled.
- b. Requires Option B7E
- c. Requires Option 106 Bluetooth FM demodulation.

| | Specifications | Supplemental Information |
|---|----------------|---|
| Initial Carrier Frequency Tolerance (ICTF) ^a (Option 106 and AYX or B7D) | | |
| Range at RF Input | 30 to -40 dBm | |
| (Option 1DS) | 30 to -60 dBm | |
| Measurement range | | ± 100 kHz, nominal |
| Measurement accuracy | | ± 4 kHz, nominal (25 measurement averages, signal level > -30 dBm) |

| | Specifications | Supplemental Information |
|----------------|---|---------------------------------|
| Average mode | Exponential, Repeat | |
| Trigger source | Video, RF burst ^b , External, Free Run | |
| Burst synch | RF Amplitude, Preamble ^c , None | |
| Limits | ICFT upper/lower | |

- a. The DUT must have frequency hopping disabled.
- b. Requires Option B7E
- c. Requires Option 106 Bluetooth FM demodulation.

FM Demodulation (Option BAA)

The FM demodulation characteristics will apply after an **Align Now, FM Demod** has been run.

| | Specifications | Supplemental Information |
|---|----------------|---|
| Optimum Input Level | | $\geq (-60 \text{ dBm} + \text{attenuator setting} - \text{preamp gain})$ and within 30 dB of the reference level |
| FM Deviation | | |
| Range | | 10 kHz to 1 MHz |
| Resolution | | Provides 1 Hz display annotation resolution |
| FM Deviation Range | | |
| 10 kHz to 40 kHz | | 12 Hz, characteristic |
| >40 kHz to 200 kHz | | 60 Hz, characteristic |
| >200 kHz to 1 MHz | | 300 Hz, characteristic |
| Accuracy ^a | | |
| FM Rate < FM BW/100, VBW $\geq (30 \times \text{FM Rate})$, RBW > the maximum of (30 \times FM deviation) or (30 \times FM Rate) | | < (2% of FM deviation range + 2 \times Resolution), characteristic |
| Offset Error ^a | | 5% of FM Deviation Range + 300 Hz, characteristic |
| FM Bandwidth (-3 dB) | | |
| FM Deviation Range | | |
| 10 kHz to 40 kHz | | 7.5 \times FM deviation range, characteristic |
| >40 kHz to 200 kHz | | 1.3 \times FM deviation range, characteristic |
| >200 kHz to 1 MHz | | 0.3 \times FM deviation range, characteristic |

a. In time domain sweeps (span = 0 Hz).

TV Trigger and Picture On Screen (Option B7B)*Option BAA is required.*

| | Specifications | Supplemental Information |
|---|---|--|
| TV Trigger and Picture On Screen | | TV Trigger initiates a sweep of the analyzer after the sync pulse of a selected line of a TV video field. Picture On Screen displays the TV picture on the analyzer display. |
| Amplitude Requirements TV Source: SA | | Top 50% of linear display, characteristic |
| TV Source: EXT VIDEO IN | | 500 mV _{p-p} to 2 V _{p-p} , characteristic |
| Compatible Standards | NTSC-M, NTSC-Japan, PAL-M, PAL-B,D,G,H,I, PAL-N, PAL-N Combination, SECAM-L | |
| Field Selection | Entire frame, even, odd | |
| Sync Polarity | Positive or negative | |
| TV Trigger | | |
| Line Selection | 1 to 525, or 1 to 625, standard dependent | |

cdmaOne Measurement Personality (Option BAC)

Unless otherwise noted, all specifications are with RF input range auto, default cdmaOne measurement settings, and in the in-band frequency range. *Option B72* is required.

| | Specifications | Supplemental Information |
|--------------------------------|--|--------------------------|
| In-Band Frequency Range | | |
| Cellular bands | 824 to 870 MHz 869 to 925 MHz | |
| PCS bands | 1715 to 1780 MHz 1805 to 1870 MHz 1850 to 1910 MHz 1930 to 1990 MHz | |

| | Specifications | Supplemental Information |
|---|----------------------------|---|
| Adjacent Channel Power Ratio^a | | |
| Carrier power range at RF Input | 30 to -20 dBm | |
| Dynamic range ^b | | Referenced to average power of carrier in 1.23 MHz BW |
| Offset Frequency | Integration BW | |
| 750 kHz | 30 kHz | -70.0 dBc, characteristic |
| 885 kHz | 30 kHz | -73.5 dBc, characteristic |
| 1.25625 MHz | 12.5 kHz | -78.0 dBc, characteristic |
| 1.98 MHz | 30 kHz | -75.5 dBc, characteristic |
| 2.75 MHz | 1 MHz | -60.5 dBc, characteristic |
| Relative accuracy ^c | See Display Scale Fidelity | |
| Resolution | 0.01 dB | |

- a. This measurement is available with personality revisions of A.02.00 or later.
- b. IS-97A nominal base station test model levels (fraction of carrier power); Pilot: 0.20 (-7.0 dBc), Sync: 0.0471 (-13.3 dBc), Paging: 0.1882 (-7.3 dBc), 6 Traffic channels: 0.09412 (-10.3 dBc)
- c. Does not include uncertainty due to noise.

| | Specifications | Supplemental Information |
|--|----------------|--------------------------------------|
| Channel Power (1.23 MHz Integration BW) | | Integration BW range 1 kHz to 10 MHz |
| Range at RF Input | 30 to -70 dBm | |
| Absolute power accuracy for in-band signal (Mean channel power at RF Input, plus any external attenuation, excluding mismatch error) | | |
| Cellular Bands | | |
| 30 to -5 dBm 20 to 30 °C | ±0.82 dB | ±0.39 dB, typical |
| 0 to 55 °C | ±1.09 dB | |
| -5 to -25 dBm 20 to 30 °C | ±0.78 dB | ±0.37 dB, typical |
| 0 to 55 °C | ±1.05 dB | |
| -25 to -45 dBm 20 to 30 °C | ±0.69 dB | ±0.21 dB, typical |
| 0 to 55 °C | ±0.94 dB | |
| -45 to -55 dBm 20 to 30 °C | ±0.77 dB | ±0.28 dB, typical |
| 0 to 55 °C | ±0.96 dB | |
| -55 to -70 dBm 20 to 30 °C | ±0.89 dB | ±0.38 dB, typical |
| 0 to 55 °C | ±1.21 dB | |
| PCS Bands | | |
| 30 to -5 dBm 20 to 30 °C | ±0.78 dB | ±0.26 dB, typical |
| 0 to 55 °C | ±1.11 dB | |
| -5 to -25 dBm 20 to 30 °C | ±0.74 dB | ±0.23 dB, typical |
| 0 to 55 °C | ±1.02 dB | |
| -25 to -45 dBm 20 to 30 °C | ±0.71 dB | ±0.26 dB, typical |
| 0 to 55 °C | ±0.99 dB | |

Agilent E4404B Specifications and Characteristics
Options

| | Specifications | Supplemental Information |
|-------------------------------|----------------|--------------------------|
| -45 to -55 dBm 20 to 30 °C | ±0.79 dB | ±0.33 dB, typical |
| 0 to 55 °C | ±1.01 dB | |
| -55 to -70 dBm 20 to 30 °C | ±0.91 dB | |
| 0 to 55 °C | ±1.26 dB | |

| | Specifications | Supplemental Information |
|---|----------------------------|--------------------------|
| Channel power relative power accuracy (same channel, different Tx power, input attenuator fixed, RF input range manual). | See Display Scale Fidelity | |

| | Specifications | Supplemental Information |
|------------------------------|----------------|--------------------------|
| Receive Channel Power | | |
| Absolute Power Accuracy | | |
| Cellular bands | | |
| 30 to 0 dBm | ±0.95 dB | ±0.53 dB, typical |
| 0 to -85 dBm | ±1.46 dB | ±0.63 dB, typical |
| PCS bands | | |
| 30 to 0 dBm | ±0.97 dB | ±0.52 dB, typical |
| 0 to -85 dBm | ±1.35 dB | ±0.59 dB, typical |
| Preamp (<i>Option IDS</i>) | | |
| Cellular and PCS bands | | |
| 30 to -80 dBm | ±1.88 dB | ±1.15 dB, typical |
| -80 to -100 dBm | ±2.95 dB | ±1.93 dB, typical |

| | Specifications | Supplemental Information |
|--|----------------|--------------------------|
| Occupied Bandwidth | | |
| Carrier power range | 30 to -45 dBm | |
| Frequency resolution of occupied BW | 1.88 kHz | |
| Frequency accuracy of occupied BW (1.23 MHz channel BW) | | ±15 kHz, characteristic |
| Frequency resolution of delta frequency | 3.75 kHz | |

| | Specifications | Supplemental Information |
|---------------------------------------|----------------|--|
| Frequency accuracy of delta frequency | | $\pm (35 \text{ kHz} + \text{frequency reference error} \times \text{carrier frequency})$, characteristic |

| | Specifications | Supplemental Information |
|---|--------------------|--|
| Code Domain Power (Requires <i>Options 1D5, B7D, and B7E</i> . Measurement interval ≥ 1.25 ms unless otherwise noted.) | | |
| Carrier power range at RF Input (Pilot channel power > -11 dBc) | 30 to -13 dBm | 30 to -65 dBm ^a , characteristic |
| Preamplifier (<i>Option 1D5</i>) | 30 to -30 dBm | 30 to -82 dBm ^a , characteristic |
| Measurement interval range | 0.5 ms to 26.67 ms | |
| Code domain power | | |
| Display dynamic range | 50 dB | |
| Accuracy (Walsh channel power within 20 dB of total power) | | ± 0.2 dB, typical |
| Displayed resolution | 0.01 dB | |
| Other reported power parameters (dB referenced to total power) | | Average active traffic, maximum inactive traffic, average inactive traffic, pilot, paging, sync channels |
| Carrier frequency error (Measurement interval ≥ 2.5 ms) | | Excludes frequency reference error. |
| Input frequency error range | ± 100 kHz | ± 200 kHz, typical |
| Accuracy | ± 10 Hz | ± 7 Hz, typical |
| Displayed resolution | Four digits | |
| Estimated Rho | | |
| Range | 0.9 to 1.0 | 0.5 to 1.0 ^b |
| Accuracy (With 9 channels active over the specified range) ^c | | ± 0.02 , characteristic |
| Displayed resolution | 0.0001 | |

| | Specifications | Supplemental Information |
|---|------------------------|---|
| Pilot time offset | | From even second signal to start of PN sequence |
| Range | –13.33 ms to +13.33 ms | |
| Accuracy | ±150 ns | |
| Displayed resolution | Four digits | |
| Code domain timing | | Pilot to code channel time tolerance |
| Range | ±200 ns | |
| Accuracy (IS-97A nominal power levels) ^d | | ±7 ns, typical |
| Code domain phase | | Pilot to code channel phase tolerance |
| Range | ±200 mrad | |
| Accuracy (IS-97A nominal power levels) ^d | | ±10 mrad, typical |
| Displays | | Power Graph and Metrics, or Power, Timing, and Phase Graphs |

- a. Performance may degrade outside of the specified carrier power range at RF input listed in the specifications column.
- b. Performance may degrade outside of the estimated rho range listed in the specifications column.
- c. The Active Set Threshold is less than all active channels, but greater than –20 dBc.
- d. IS-97A nominal base station test model levels (fraction of carrier power); Pilot: 0.20 (–7.0 dBc), Sync: 0.0471 (–13.3 dBc), Paging: 0.1882 (–7.3 dBc), 6 Traffic channels: 0.09412 (–10.3 dBc)

| | Specifications | Supplemental Information |
|---|---------------------|---|
| Modulation Accuracy (Rho) (Requires <i>Options 1D5, B7D, and B7E</i> . Measurement interval ≥1.25 ms unless otherwise noted.) | | |
| Carrier power range at RF Input | 30 to –28 dBm | 30 to –70 dBm ^a , characteristic |
| Preamp (<i>Option 1DS</i>) | 30 to –45 dBm | 30 to –87 dBm ^a , characteristic |
| Measurement interval range | 0.15 ms to 26.67 ms | |
| Rho (waveform quality) | | |
| Range | 0.9 to 1.0 | 0.5 to 1.0 ^b , characteristic |
| Accuracy | | ±0.0016, typical |
| Displayed resolution | 0.0001 | |

| | Specifications | Supplemental Information |
|---|------------------------|--|
| Carrier frequency error (Measurement interval ≥ 2.5 ms) | | Excludes frequency reference error |
| Input frequency error range | ± 100 kHz | ± 200 kHz, typical |
| Accuracy | ± 10 Hz | ± 7 Hz, typical |
| Displayed resolution | Four digits | |
| Pilot time offset | | From even second signal to start of PN sequence |
| Range | -13.33 ms to +13.33 ms | |
| Accuracy | ± 150 ns | |
| Displayed resolution | Four digits | |
| EVM | | |
| Floor | | 3.8%, typical |
| Accuracy ^c | | $\pm 1.1\%$, typical |
| Displayed Resolution | 0.01% | |
| Carrier feedthrough | | |
| Floor | | -51 dBc, typical |
| Accuracy (Carrier feedthrough ≥ -43 dBc) | | ± 2.3 dB, typical |
| Displayed resolution | 0.01 dB | |
| Magnitude error | | |
| Floor | | 3.8%, typical |
| Accuracy ^c | | $\pm 1.1\%$, typical |
| Displayed resolution | 0.01% | |
| Phase error | | |
| Accuracy ^c | | ± 0.65 degrees, typical |
| Displayed resolution | 0.01 degrees | |
| Displays | | Numeric results or Numeric results and IQ graph |

- a. Performance may degrade outside of the specified carrier power range at RF input listed in the specifications column.
- b. Performance may degrade outside of the rho range listed in the specifications column.
- c. Accuracy does not include the effects of the EVM floor. The measurement variance increases as the result approaches the EVM floor.

Agilent E4404B Specifications and Characteristics
Options

| | Specifications | Supplemental Information |
|---------------------------------|--|--|
| Spur Close (In Band) | | |
| Carrier power range at RF Input | 30 to -12 dBm | |
| Dynamic range | | |
| Input power | | |
| 30 to 25 dBm | 55 dB | |
| 25 to 20 dBm | 50 dB | |
| 20 to -12 dBm | 46 dB | |
| Relative accuracy | $\pm(2.7 \text{ dB} + 0.01 \times (\text{dB from reference level}))$ | $\pm(0.3 \text{ dB} + 0.01 \times (\text{dB from reference level}))$, typical |
| Displayed resolution | 0.01 dB | |

| | Specifications | Supplemental Information |
|---|----------------|--|
| Out-of-Band Spurious^a | | Refer to the Amplitude specifications section in this guide. |

- a. The out-of-band measurement is made with the user-defined tables with 20 frequency ranges each (up to the top 10 spurs per range, 100 spurs maximum). Table parameters include frequency range, RBW, video BW, detector type, and amplitude test limits.

| | Specifications | Supplemental Information |
|---|----------------------|--------------------------------|
| Receiver Spurious Emissions | | |
| Spurious emission power range | -20 to -83 dBm | |
| Preamp On (<i>Option 1DS</i>) | -40 to -101 dBm | |
| Absolute spurious emission power accuracy | | |
| -20 to -60 dBm | $\pm 2.0 \text{ dB}$ | $\pm 1.1 \text{ dB}$, typical |
| -60 to -83 dBm | $\pm 3.8 \text{ dB}$ | $\pm 2.7 \text{ dB}$, typical |
| Preamp On (<i>Option 1DS</i>) | | |
| -40 to -70 dBm | $\pm 2.5 \text{ dB}$ | $\pm 1.3 \text{ dB}$, typical |
| -70 to -101 dBm | $\pm 4.0 \text{ dB}$ | $\pm 2.6 \text{ dB}$, typical |

| | Specifications | Supplemental Information |
|--|----------------|--------------------------|
| External Correction | | |
| External attenuation, external gain | | |
| Range | -90 to 90 dB | |
| Resolution | 0.01 dB | |

| | Specifications | Supplemental Information |
|--|---------------------|---|
| Trigger | | |
| Trigger source (Actual available choices dependent on measurement) | Free run, external | |
| <i>(Option B7D and B7E)</i> | Add RF Burst, frame | |
| Delay trigger | | |
| Range | 0 to 500 ms | |
| Resolution | 300 ns | |
| RF burst trigger level (<i>Option B7E</i>) | 0 to -25 dBc | |
| Trigger slope (External and RF burst) | Positive/Negative | |
| Frame timing period | 50 ns to 13.6533 s | |
| Frame synchronizing source | External frame sync | Rear panel connector labelled EXT FRAME SYNC (<i>Option B7D</i>) |
| Frame synchronizing slope | Positive/Negative | |

| | Specifications | Supplemental Information |
|---|-----------------------|---|
| Demod Trigger Source | | |
| Even second input (Frame trigger only, <i>Option B7D</i> and <i>B7E</i>) | | Rear panel connector labelled EXT FRAME SYNC |
| PN offset range | 0 to 511 x 64 [chips] | |

Options**GSM Measurement Personality (Option BAH)**

Unless otherwise noted, all specifications are with RF input range auto, default GSM measurement settings, and in the in-band frequency range. *Option 1D6* and *Option B72* are required.

| | Specifications | Supplemental Information |
|--------------------------------|--------------------------------------|--------------------------|
| In-Band Frequency Range | | |
| GSM 900, P-GSM bands | 890 to 915 MHz 935 to 960 MHz | |
| GSM 900, E-GSM bands | 880 to 915 MHz 925 to 960 MHz | |
| GSM 900, R-GSM bands | 876 to 915 MHz 921 to 960 MHz | |
| DCS 1800 bands | 1710 to 1785 MHz 1805 to 1880 MHz | |
| PCS 1900 bands | 1850 to 1910 MHz 1930 to 1990 MHz | |

| | Specifications | Supplemental Information |
|--|----------------|--------------------------|
| Transmitter Power (Requires <i>Option B7D</i> or <i>AYX</i>) | | |
| Range at RF Input | 30 to -60 dBm | |
| Absolute power accuracy for in-band signal (Mean channel power at RF Input, plus any external attenuation, excluding mismatch error) | | |
| P-GSM, E-GSM, and R-GSM Bands | | |
| 30 to -20 dBm 20 to 30 °C | ±0.81 dB | ±0.34 dB, typical |
| 0 to 55 °C | ±1.25 dB | |
| -20 to -30 dBm 20 to 30 °C | ±0.74 dB | ±0.31 dB, typical |
| 0 to 55 °C | ±1.06 dB | |

| | Specifications | Supplemental Information |
|-------------------------------|----------------|--------------------------|
| -30 to -40 dBm 20 to 30 °C | ±0.79 dB | ±0.31 dB, typical |
| 0 to 55 °C | ±1.05 dB | |
| -40 to -50 dBm 20 to 30 °C | ±0.95 dB | ±0.47 dB, typical |
| 0 to 55 °C | ±1.15 dB | |
| -50 to -60 dBm 20 to 30 °C | ±1.09 dB | ±0.60 dB, typical |
| 0 to 55 °C | ±1.27 dB | |
| DCS 1800 and PCS 1900 Bands | | |
| 30 to -20 dBm 20 to 30 °C | ±0.77 dB | ±0.29 dB, typical |
| 0 to 55 °C | ±1.27 dB | |
| -20 to -30 dBm 20 to 30 °C | ±0.70 dB | ±0.28 dB, typical |
| 0 to 55 °C | ±1.05 dB | |
| -30 to -40 dBm 20 to 30 °C | ±0.75 dB | ±0.28 dB, typical |
| 0 to 55 °C | ±1.04 dB | |
| -40 to -50 dBm 20 to 30 °C | ±0.91 dB | ±0.44 dB, typical |
| 0 to 55 °C | ±1.14 dB | |
| -50 to -60 dBm 20 to 30 °C | ±1.05 dB | ±0.57 dB, typical |
| 0 to 55 °C | ±1.26 dB | |

| | Specifications | Supplemental Information |
|---|----------------------------|--------------------------|
| Transmitter Power Relative Power Accuracy (same channel, different Tx power, input attenuator fixed, RF input range manual). | See Display Scale Fidelity | |

Options

| | Specifications | Supplemental Information |
|---|-----------------------|---|
| Power versus Time (Requires <i>Option B7D</i> or <i>AYX</i>) | | |
| Carrier power range at RF Input | 30 to –23 dBm | 30 to –55 dBm ^a , characteristic |
| Preamp On (<i>Option 1DS</i>) | 30 to –40 dBm | 30 to –72 dBm ^a , characteristic |
| Time resolution accuracy | | ±1% of sweep time, characteristic |
| Maximum record length | 8 time slots | |
| Burst to mask uncertainty (Requires <i>Option B7D</i> and <i>B7E</i>) | ±1.0 bit | |

a. Performance may degrade outside of the specified carrier power range at RF input listed in the specifications column.

| | Specifications | Supplemental Information |
|--|--|---------------------------------|
| Output RF Spectrum | | |
| Carrier power range at RF Input | | |
| Offsets ≤1800 kHz, 30 kHz RBW | | 30 to –5 dBm, characteristic |
| Offsets >1800 kHz, 100 kHz RBW | | 30 to –4 dBm, characteristic |
| Reference power accuracy | Same as Transmitter Power measurement | |
| Relative accuracy ^a | See Display Scale Fidelity | |
| Spectrum due to modulation displayed dynamic range ^{b,c} | | |
| 100 kHz offset | | 30 dB, characteristic |
| 200 kHz offset | | 60 dB, characteristic |
| 250 kHz offset | | 60 dB, characteristic |
| 400 kHz offset | | 70 dB, characteristic |
| 600 kHz to 1.8 MHz offset | | 79 dB, characteristic |
| 1.8 to 6.0 MHz offset | | 75 dB, characteristic |
| > 6 MHz offset | | 76 dB, characteristic |
| Swept Mode Dynamic Range | | 70 dB, characteristic |

| | Specifications | Supplemental Information |
|---|----------------|--------------------------|
| Spectrum due to switching transients displayed dynamic range ^{b,c} | | |
| 400 kHz offset | | 62 dB, characteristic |
| 600 kHz offset | | 79 dB, characteristic |
| 1200 kHz offset | | 79 dB, characteristic |
| 1800 kHz offset | | 80 dB, characteristic |
| Swept Mode Dynamic Range | | 70 dB, characteristic |

- a. Does not include uncertainty due to noise.
- b. Displayed dynamic range for specific frequency offsets—applies to CW signal at the specified offset. Dynamic range with a GSM signal may differ.
- c. Using default settings, the RBW filter has a corrected noise BW and impulse BW equivalent to five-pole synchronously tuned filter.

| | Specifications | Supplemental Information |
|---|----------------|---|
| Phase and Frequency Error (Requires <i>Option 1D5, B7D, and B7E</i>) | | |
| Carrier power range at RF Input | 30 to -23 dBm | 30 to -55 dBm ^a , characteristic |
| Preamplifier On (<i>Option 1DS</i>) | 30 to -40 dBm | 30 to -72 dBm ^a , characteristic |
| Phase error | | |
| Range | 0 to 180° | |
| Displayed resolution | 0.01° | |
| Accuracy (Averages ≥10) | | |
| Peak | ±2.1° | ±1.5°, typical |
| RMS | ±1.1° | ±0.6°, typical |
| Frequency error | | Excludes frequency reference error |
| Initial frequency error range | ±100 kHz | |
| Accuracy (Averages ≥10) | ±10 Hz | ±5 Hz, typical |
| I/Q offset range | -10 to -46 dBc | |
| Burst sync time uncertainty | ±0.1 bit | |
| Displays | | Numeric summary |

- a. Performance may degrade outside of the specified carrier power range at RF input listed in the specifications column.

| | Specifications | Supplemental Information |
|-----------------------------------|----------------|---|
| Transmit Band Spurious | | |
| Carrier power range at RF Input | | 30 to -12 dBm, typical |
| Dynamic range | | |
| Upper and lower adjacent segments | | 55 dB, characteristic |
| Upper and lower segments | | 44 dB, characteristic |
| Relative accuracy | | $\pm(0.3 \text{ dB} + 0.01 \times (\text{dB from reference level}))$, characteristic |
| Displayed resolution | 0.01 dB | |

| | Specifications | Supplemental Information |
|---|----------------|--|
| Out-of-Band Spurious^a | | |
| Absolute Spurious Power Accuracy | | Refer to the Amplitude specifications section in this guide. |
| Sensitivity ^b | | |
| RBW | | |
| 1 kHz | | -95 dBm, characteristic |
| 3 kHz | | -90 dBm, characteristic |
| 10 kHz | | -85 dBm, characteristic |
| 30 kHz | | -78 dBm, characteristic |
| 100 kHz | | -71 dBm, characteristic |
| 300 kHz | | -64 dBm, characteristic |
| 1 MHz | | -57 dBm, characteristic |
| 3 MHz | | -50 dBm, characteristic |

- a. The out-of-band spurious measurement is made in accordance with the tables defined in the appropriate GSM specification document. The measurement is made over several frequency ranges (up to 10 spurs per range, 100 spurs maximum).
- b. With input attenuation of 5 dB. For all other attenuation settings, add (input attenuation - 5) dB.

| | Specifications | Supplemental Information |
|--|----------------|--------------------------------|
| Receive Band Spurious | | |
| Spurious emission power range ^a | | |
| Preamp On (<i>Option 1DS</i>) | | -20 to -73 dBm, characteristic |
| | | -40 to -91 dBm, characteristic |

| | Specifications | Supplemental Information |
|---|----------------|--------------------------|
| Absolute spurious emission power accuracy | | |
| –20 to –60 dBm | | ±1.4 dB, characteristic |
| –60 to –73 dBm | | ±2.0 dB, characteristic |
| Preamp on (<i>Option 1DS</i>) | | |
| –40 to –70 dBm | | ±1.8 dB, characteristic |
| –70 to –91 dBm | | ±3.0 dB, characteristic |

a. Requires bandpass filter centered on receive band, peak detector mode, 0 dB attenuation, 100 kHz RBW. Does not include insertion loss of bandpass filter.

| | Specifications | Supplemental Information |
|--------------------------------|----------------|---|
| Amplitude Range Control | | RF Input Autorange, Manually set Max Total Pwr Manually set Input Atten |

| | Specifications | Supplemental Information |
|--|----------------|--------------------------|
| External Gain/Attenuation Correction | | |
| Base gain, base attenuation, mobile gain, mobile attenuation | | |
| Range | 0 to 81.9 dB | |
| Resolution | 0.01 dB | |

| | Specifications | Supplemental Information |
|--|-------------------------------------|--------------------------|
| Trigger | | |
| Trigger source (Actual available choices dependent on measurement) | Free run, external | |
| (<i>Option B7D and B7E</i>) | Add RF Burst and frame | |
| RF burst trigger (<i>Option B7E</i>) | | |
| Peak carrier power range ^a | 30 to –25 dBm | 30 to –30 dBm, typical |
| Preamp On (<i>Option 1DS</i>) | 30 to –45 dBm | 30 to –50 dBm, typical |
| Trigger level range | 0 to –25 dB relative to signal peak | |

a. With trigger level set to –6 dB.

Options

| | Specifications | Supplemental Information |
|---|--|--|
| <p>Burst Sync (Requires <i>Option AYX</i> or <i>B7D</i>)</p> <p>Source (Actual available choices dependent on measurement)</p> <p>(<i>Option B7D</i> and <i>B7E</i>)</p> <p>Training sequence code</p> <p>Burst type</p> | <p>RF amplitude, none</p> <p>Add training sequence</p> | <p>GSM defined 0 to 7 Auto (search) or Manual</p> <p>Normal (TCH and CCH) Sync (SCH) Access (RACH)</p> |

General

| | Specifications | Supplemental Information |
|--------------------------|----------------|--------------------------|
| Temperature Range | | |
| Operating | 0 to 55 °C | Floppy disk 10 to 40 °C |
| Storage | -40 to 75 °C | |

| | Specifications | Supplemental Information |
|-------------------------------------|----------------|----------------------------|
| Audible Noise (ISO 7779) | | |
| Sound Pressure at 25 °C | | <40 dBa, (<4.6 Bels power) |

| | Specifications | Supplemental Information |
|-------------------------------|---|--------------------------|
| Military Specification | Has been type tested to the environmental specifications of MIL-PRF-28800F class 3. | |

| | Specifications | Supplemental Information |
|---------------------------------|---|--------------------------|
| EMI Compatibility | Conducted and radiated emission is in compliance with CISPR Pub. 11/1990 Group 1 Class A. | |
| <i>(Option 060)^a</i> | Conducted and radiated emission is in compliance with CISPR Pub. 11/1990 Group 1 Class B ^b . | |

a. Option 060 is not compatible with Option B7B nor Option 1DP.

b. Meets Class A performance during dc operation.

| | Specifications | Supplemental Information |
|-------------------------|----------------|---|
| Immunity Testing | | |
| Radiated Immunity | | Testing was done at 3 V/m according to IEC 801-3/1984. When the analyzer tuned frequency is identical to the immunity test signal frequency, there may be signals of up to -60 dBm displayed on the screen. |

| | Specifications | Supplemental Information |
|-------------------------|-----------------------|---|
| Electrostatic Discharge | | Air discharges of up to 8 kV were applied according to IEC 801-2/1991. Discharges to center pins of any of the connectors may cause damage to the associated circuitry. |

| | Specifications | Supplemental Information |
|----------------------------|--|---------------------------------|
| Power Requirements | | |
| ac Operation | | |
| Voltage, frequency | 90 to 132 Vrms, 47 to 440 Hz 195 to 250 Vrms, 47 to 66 Hz | |
| Power Consumption, On | <300 W | |
| Power Consumption, Standby | <5 W | |
| dc Operation | | |
| Voltage | 12 to 20 Vdc | |
| Power Consumption | <200 W | |
| Power Consumption, Standby | <100 mW | |

| | Specifications | Supplemental Information |
|--|-----------------------|---------------------------------|
| Measurement Speed | | |
| Local Measurement and Display Update rate ^a | | |
| Sweep points = 101 | | ≥ 40/s, characteristic |
| Sweep points = 401 | | ≥ 28/s, characteristic |
| Remote Measurement and GPIB Transfer Rate ^{b,c} | | |
| <i>(Option A4H)</i> | | |
| Sweep points = 101 | | ≥ 40/s, characteristic |
| Sweep points = 401 | | ≥ 28/s, characteristic |

| | Specifications | Supplemental Information |
|--|----------------|--|
| RF Center Frequency Tune, Measure, and GPIB Transfer Time ^{b,d} (Option A4H) Sweep points = 101 Sweep points = 401 | | ≤ 75 ms, characteristic ≤ 90 ms, characteristic |

- a. Factory preset, auto align Off, segmented sweep Off, fixed center frequency, RBW = 1 MHz, spans >10 MHz and ≤600 MHz, and stop frequency ≤3 GHz.
- b. Display Off (:DISPlay:ENABle OFF), and 32-bit integer data format (:FORMat:DATA INT,32), if *Option AYX* or *A4J* is installed, disable sweep ramp, (:SYSem:PORTs:IFVSweep:ENABle OFF), markers Off, single sweep, measured with IBM compatible PC with 550 MHz Pentium® III running Windows® NT 4.0, one meter GPIB cable, National Instruments PCI-GPIB card and NI-488.2 DLL.
- c. Factory preset, auto align Off, fixed center frequency, RBW = 1 MHz, and span = 20 MHz, fixed center frequency, stop frequency ≤3 GHz, average of 100 measurements.
- d. Factory preset, auto align Off, segmented sweep Off, RBW = 1 MHz, span= 20 MHz, stop frequency ≤3 GHz, center frequency tune step size = 50 MHz.

| | Specifications | Supplemental Information |
|--|----------------|--|
| Data Storage Internal External (10 to 40 °C) 3.5" 1.44 MB, MS-DOS® compatible floppy disk | | 200 Traces or States ^a 200 Traces or States ^a |

- a. When storing traces set to 401 points.

| | Specifications | Supplemental Information |
|---|----------------|---|
| Downloadable Program Memory (<i>Option B72</i>) | | 2 MB available memory 10 MB available memory |

| | Specifications | Supplemental Information |
|---|-----------------------|---|
| Demod Tune and Listen Demod <i>(Option BAA or 106)</i> <i>(Option A4J or AYX)</i> <i>(Option 106 or BAA)</i> | AM Add FM | Internal speaker, front-panel earphone jack and front-panel volume control. An uncalibrated demodulated signal is available on the AUX VIDEO OUT connector at the rear panel. An uncalibrated demodulated signal is available on the EXT VIDEO OUT connector at the rear panel. |

| | Specifications | Supplemental Information |
|--|-----------------------|--|
| Weight (without options) Net Shipping | | 17.1 kg (37.7 lb), characteristic 31.9 kg (70.3 lb), characteristic |

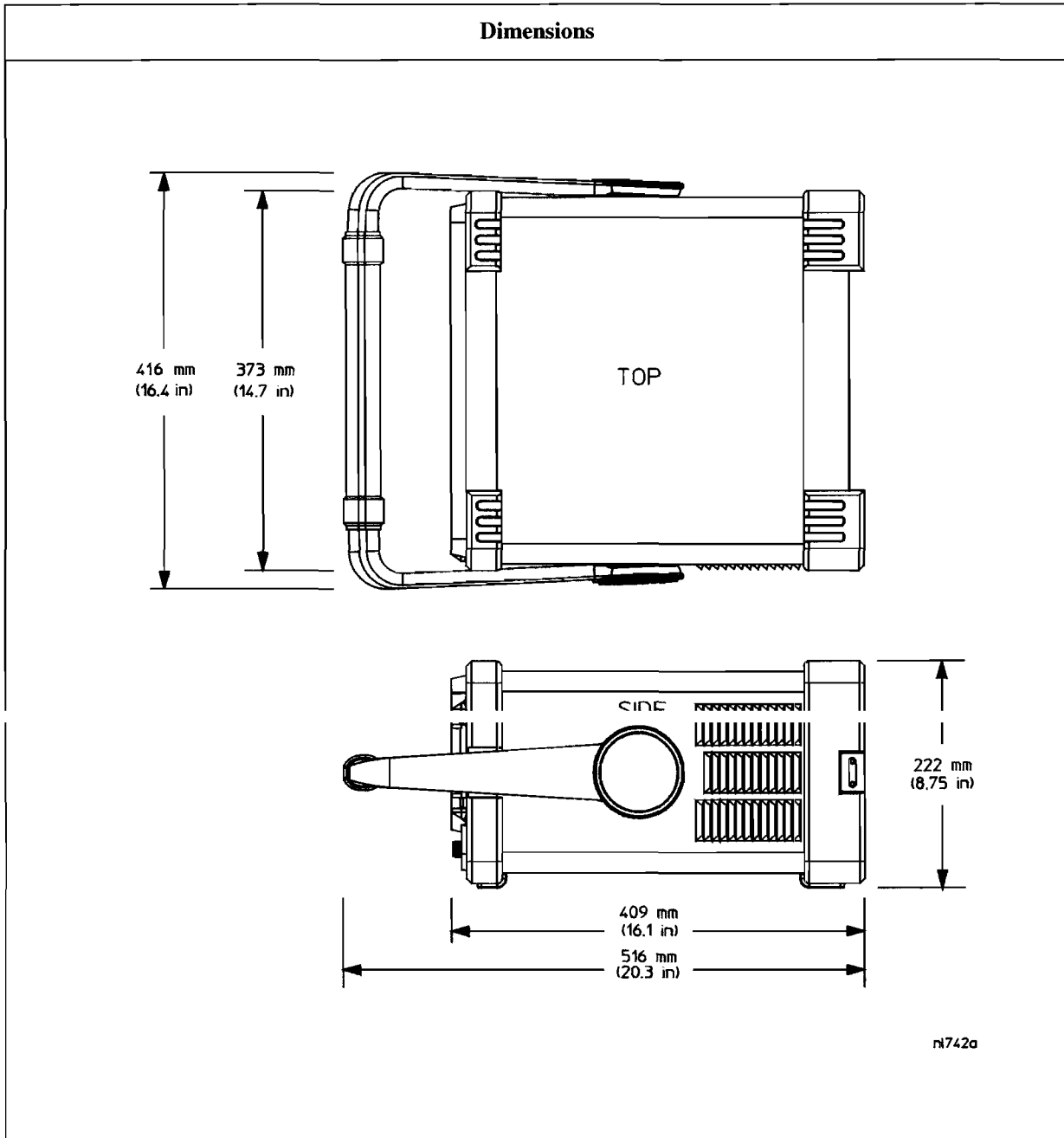

Inputs and Outputs

Front Panel

| | Specifications | Supplemental Information |
|-------------------|----------------|--------------------------|
| INPUT 50 Ω | | |
| Connector | Type-N female | |
| Impedance | | 50 Ω, nominal |

| | Specifications | Supplemental Information |
|----------------------------------|----------------|--------------------------|
| RF OUT 50 Ω, (Option 1DN) | | |
| Connector | Type-N female | |
| Impedance | | 50 Ω, nominal |

| | Specifications | Supplemental Information |
|----------------------------------|----------------|--|
| AMPTD REF OUT^a | | Amplitude Reference |
| Connector | BNC female | |
| Impedance | | 50 Ω, nominal |
| Frequency | | 50 MHz |
| Frequency Accuracy | | Frequency reference error ^b |
| 50 Ω Amplitude ^c | | -20 dBm, nominal |

- Turn the amplitude reference on/off by pressing the keys: **Input/Output, Amptd Ref Out**.
- Frequency reference error = (aging rate × period of time since adjustment + settability + temperature stability).
- The internal amplitude reference actual power is stored internally.

| | Specifications | Supplemental Information |
|--------------------|----------------|--|
| PROBE POWER | | |
| Voltage/Current | | +15 Vdc, ±7% at 150 mA max., characteristic -12.6 Vdc ±10% at 150 mA max., characteristic |

| | Specifications | Supplemental Information |
|---------------------------------|----------------|---|
| EXT KEYBOARD^a | | Used for entering screen titles and filenames only. Interface compatible with most IBM-compatible PC keyboards. |
| Connector | 6-pin mini-DIN | |

a. The feature is not implemented in firmware revisions prior to A.04.00.

| | Specifications | Supplemental Information |
|----------------|----------------|----------------------------------|
| Speaker | | Front panel knob controls volume |

| | Specifications | Supplemental Information |
|------------------|--|--|
| Headphone | | Front panel knob controls volume |
| Connector | 3.5 mm (1/8 inch) miniature audio jack | |
| Power Output | | 0.2 W into 4 Ω , characteristic |

Rear Panel

| | Specifications | Supplemental Information |
|-----------------------|----------------|--------------------------|
| 10 MHz REF OUT | | |
| Connector | BNC female | |
| Impedance | | 50 Ω , nominal |
| Output Amplitude | | >0 dBm, characteristic |

| | Specifications | Supplemental Information |
|-----------------------|----------------|---|
| 10 MHz REF IN | | |
| Connector | BNC female | Note: Analyzer noise sidebands and spurious response performance may be affected by the quality of the external reference used. |
| Impedance | | 50 Ω , nominal |
| Input Amplitude Range | | -15 to +10 dBm, characteristic |
| Frequency | | 10 MHz, nominal |

Agilent E4404B Specifications and Characteristics
Inputs and Outputs

| | Specifications | Supplemental Information |
|--|--|---------------------------------|
| EXT REF IN <i>(Option B7E)</i> | | |
| Connector | BNC, female | 50 Ω, nominal |
| Impedance | | |
| Input amplitude range | -5 to 10 dBm | |
| Frequency | 1 to 30 MHz, selectable | |
| Frequency lock range | $\pm 5 \times 10^{-6}$ of specified external reference input frequency | |

| | Specifications | Supplemental Information |
|--|-----------------------|------------------------------------|
| 10 MHz OUT <i>(Option B7E)</i> | | |
| Connector | BNC, female | 50 Ω, nominal |
| Impedance | | |
| Frequency | | |
| Level | | |
| | | 10 MHz, nominal |
| | | 0 dBm when Option 10 MHz Out is On |

| | Specifications | Supplemental Information |
|--|-----------------------|---|
| GATE TRIG/EXT TRIG IN | | |
| Connector | BNC female | Selectable positive or negative edge initiates sweep in EXT TRIG mode (5 V TTL) |
| External Trigger Input | | |
| Trigger Level | | |
| Gate Trigger Input <i>(Option 1D6)</i> | | |
| Minimum Pulse Width | | >30 ns (5 V TTL) |

| | Specifications | Supplemental Information |
|---|----------------|---|
| GATE/HI SWP OUT | | |
| Connector | BNC female | |
| High Sweep Output Level | | High = sweep ^a ; Low = retrace (5 V TTL) |
| Gate Output (<i>Option 1D6</i>) Level | | High = gate on; Low = gate off (5 V TTL) |

a. High sweep may be high longer than the indicated sweep times.

| | Specifications | Supplemental Information |
|-------------------|-----------------------------------|--|
| VGA OUTPUT | | |
| Connector | VGA compatible, 15-pin mini D-SUB | |
| Format | | VGA (31.5 kHz horizontal, 60 Hz vertical sync rates, non-interlaced) Analog RGB |
| Resolution | 640 × 480 | |

| | Specifications | Supplemental Information |
|--|----------------|---------------------------------------|
| AUX IF OUT (<i>Option A4J or AYX</i>) | | |
| Connector | BNC female | RBW ≥ 1 kHz |
| Frequency | | 21.4 MHz, nominal |
| Amplitude (for signal at reference level and for reference levels – input attenuation + preamp gain of –10 to –70 dBm) | | –10 dBm (uncorrected), characteristic |
| Impedance | | 50 Ω, nominal |

| | Specifications | Supplemental Information |
|--|----------------|--|
| AUX VIDEO OUT (<i>Option A4J or AYX</i>) | | |
| Connector | BNC female | RBW ≥ 1 kHz |
| Amplitude Range (into >10 kΩ) | | 0 to 1 V (uncorrected), characteristic |

Agilent E4404B Specifications and Characteristics
Inputs and Outputs

| | Specifications | Supplemental Information |
|---|-----------------------|--|
| HI SWP IN (Option A4J or AYX) | | |
| Connector | BNC female | |
| Input | | Open collector, low resets and holds the sweep (5 V TTL) |

| | Specifications | Supplemental Information |
|--|-----------------------|---|
| HI SWP OUT (Option A4J or AYX) | | |
| Connector | BNC female | |
| Output | | High = sweep ^a , Low = retrace (5 V TTL) |

a. High sweep may be high longer than the indicated sweep times.

| | Specifications | Supplemental Information |
|---------------------------------------|-----------------------|---------------------------------|
| SWP OUT (Option A4J or AYX) | | |
| Connector | BNC female | |
| Amplitude | | 0 to +10 V ramp, characteristic |

| | Specifications | Supplemental Information |
|-----------------------------|-----------------------|--|
| PRESEL TUNE OUTPUT | | |
| Connector | BNC female | |
| Load Impedance (dc coupled) | | > 10 k Ω , nominal |
| Range | | 0 to +10 V, characteristic |
| Sensitivity | | 0.33 V/GHz of tuned frequency > 3 GHz, characteristic |

| | Specifications | Supplemental Information |
|------------------------------------|------------------------|--|
| GPIB Interface (Option A4H) | | |
| Connector | IEEE-488 bus connector | |
| GPIB Codes | | SH1, AH1, T6, SR1, RL1, PP0, DC1, C1, C2, C3 and C28 |

| | Specifications | Supplemental Information |
|---|-----------------------|---------------------------------|
| Serial Interface (<i>Option 1AX</i>) | | |
| Connector | 9-pin D-SUB male | RS-232 |

| | Specifications | Supplemental Information |
|---|-----------------------|---------------------------------|
| Parallel Interface (<i>Option A4H or 1AX</i>) | | Printer port only |
| Connector | 25-pin D-SUB female | |

| | Specifications | Supplemental Information |
|--|---------------------------|--|
| EXT VIDEO IN/TV TRIG OUT^a (<i>Option B7B or BAA</i>) | | EXT VIDEO IN is the Baseband composite video input for TV trigger and picture on screen. TV TRIG OUT is the TV trigger output. |
| Connector | BNC Female (75 Ω) | |
| Impedance | | 75 Ω , nominal |
| (<i>Option BAA without Option B7B</i>) | | Feature not implemented |
| (<i>Option BAA with Option B7B</i>) | | |
| External Video Input Video Amplitude | | 1 V _{p-p} , nominal, characteristic |
| TV Trigger Output | | Positive edge indicates start of selected TV line after sync. pulse |
| Amplitude | | TTL (0 V and 3.4 V with 75 Ω series resistance), characteristic |

a. This connector is labelled EXT VIDEO IN on older spectrum analyzers and EXT VIDEO IN/TV TRIG OUT on newer spectrum analyzers.

| | Specifications | Supplemental Information |
|--|---------------------------|---|
| EXT VIDEO OUT (<i>Option B7B or BAA</i>) | | Baseband video output RBW \geq 1 kHz |
| Connector | BNC female (75 Ω) | |
| Impedance | | 75 Ω , nominal |
| (<i>Option BAA without Option B7B</i>) | | |
| Amplitude | | 0 to 1 V (uncorrected), characteristic |
| (<i>Option BAA with Option B7B</i>) | | |

Agilent E4404B Specifications and Characteristics
Inputs and Outputs

| | Specifications | Supplemental Information |
|--|---------------------------|--|
| Amplitude TV Source: SA TV Source and EXT VIDEO IN (<i>Option 106</i>) Connector Impedance Amplitude | BNC female (75 Ω) | 0 to 1 V (uncorrected), characteristic Same as level at EXT VIDEO IN/TV TRIG OUT, characteristic 75 Ω , nominal 0 to 1 V (uncorrected), characteristic |

| | Specifications | Supplemental Information |
|--|-----------------------|---------------------------------|
| EXT FRAME SYNC (<i>Option B7D</i>) Connector Level | BNC, female | 5 V TTL |

Regulatory Information

CAUTION This product is designed for use in Installation Category II and Pollution Degree 2 per IEC 1010 and 664 respectively.

NOTE This product has been designed and tested in accordance with IEC Publication 1010, Safety Requirements for Electronic Measuring Apparatus, and has been supplied in a safe condition. The instruction documentation contains information and warnings which must be followed by the user to ensure safe operation and to maintain the product in a safe condition.



The CE mark is a registered trademark of the European Community (if accompanied by a year, it is the year when the design was proven).



The CSA mark is the Canadian Standards Association safety mark.

ISM 1-A

This is a symbol of an Industrial Scientific and Medical Group 1 Class A product. (CISPR 11, Clause 4)

Declaration of Conformity

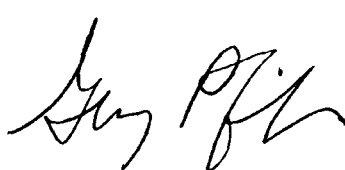
| DECLARATION OF CONFORMITY | |
|---|---|
| According to ISO/IEC Guide 22 and CEN/CENELEC EN 45014 | |
| Manufacturer's Name: | Agilent Technologies, Inc. |
| Manufacturer's Address: | 1400 Fountaingrove Parkway Santa Rosa, CA 95403-1799 USA |
| Declares that the products | |
| Product Name: | Spectrum Analyzer |
| Model Number: | E4401B, E4402B, E4403B, E4404B, E4405B, E4407B, E4408B, E4411B |
| Product Options: | This declaration covers all options of the above products. |
| Conform to the following product specifications: | |
| EMC: IEC 61326-1:1997+A1:1998 / EN 61326-1:1997+A1:1998 | |
| <u>Standard</u> | <u>Limit</u> |
| CISPR 11:1990 / EN 55011-1991 | Group 1, Class A |
| IEC 61000-4-2:1995+A1998 / EN 61000-4-2:1995 | 4 kV CD, 8 kV AD |
| IEC 61000-4-3:1995 / EN 61000-4-3:1995 | 3 V/m, 80 - 1000 MHz |
| IEC 61000-4-4:1995 / EN 61000-4-4:1995 | 0.5 kV sig., 1 kV power |
| IEC 61000-4-5:1995 / EN 61000-4-5:1996 | 0.5 kV L-L, 1 kV L-G |
| IEC 61000-4-6:1996 / EN 61000-4-6:1998 | 3 V, 0.15 - 80 MHz |
| IEC 61000-4-11:1994 / EN 61000-4-11:1998 | 1 cycle, 100% |
| Safety: IEC 61010-1:1990 + A1:1992 + A2:1995 / EN 61010-1:1993 +A2:1995 CAN/CSA-C22.2 No. 1010.1-92 | |
| Supplementary Information: The products herewith comply with the requirements of the Low Voltage Directive 73/23/EEC and the EMC Directive 89/336/EEC and carry the CE-marking accordingly. | |
|  | |
| Santa Rosa, CA, USA | 17 April 2000 |
| Greg Pfeiffer/Quality Engineering Manager | |
| For further information, please contact your local Agilent Technologies sales office, agent or distributor. | |

4

**Agilent E4405B Specifications and
Characteristics**

About This Chapter

This chapter contains specifications and characteristics for the Agilent E4405B spectrum analyzer. The distinction between specifications and characteristics is described as follows.

- Specifications describe the performance of parameters covered by the product warranty. (The temperature range is 0 °C to 55 °C, unless otherwise noted.)
- Characteristics describe product performance that is useful in the application of the product, but is not covered by the product warranty.
- Typical performance describes additional product performance information that is not covered by the product warranty. It is performance beyond specification that 80% of the units exhibit with a 95% confidence level over the temperature range 20 to 30 °C. Typical performance does not include measurement uncertainty.
- Nominal values indicate the expected performance, or describe product performance that is useful in the application of the product, but is not covered by the product warranty.

The following conditions must be met for the analyzer to meet its specifications.

- o The analyzer is within the one year calibration cycle.
- o If **Auto Align All** is selected:
 - After 2 hours of storage within the operating temperature range.
 - 5 minutes after the analyzer is turned on with sweep times less than 4 seconds.
 - After the front-panel amplitude reference is connected to the INPUT, and **Align Now RF** has been run, after the analyzer is turned on. And, once every 24 hours, or if ambient temperature changes more than 30 °C¹.

1. 10 °C if Preamp (*Option 1DS*) is active.

- o If **Auto Align Off** is selected:
 - When the analyzer is at a constant temperature, within the operating temperature range, for a minimum of 90 minutes.
 - After the analyzer is turned on for a minimum of 90 minutes, the front panel amplitude reference has been connected to the INPUT, and **Align Now All** has been run.
 - When **Align Now All** is run:
 - Every hour
 - If the ambient temperature changes more than 3 °C
 - If the 10 MHz reference changes
 - When **Align Now RF** is run (with the front-panel amplitude reference connected to the INPUT):
 - Every 24 hours
 - If the ambient temperature changes more than 30 °C¹
- o If **Auto Align All but RF** is selected:
 - When the analyzer is at a constant temperature, within the operating temperature range, for a minimum of 90 minutes.
 - After the analyzer is turned on for a minimum of 90 minutes, the front panel amplitude reference has been connected to the INPUT, and **Align Now RF** has been run.
 - When **Align Now RF** is run (with the front-panel amplitude reference connected to the INPUT):
 - Every hour
 - If the ambient temperature changes more than 3 °C

1. 10 °C if Preamp (*Option IDS*) is active.

Frequency

| | Specifications | Supplemental Information |
|-------------------------------|---------------------|--|
| Frequency Range | | |
| dc Coupled | 9 kHz to 13.2 GHz | 30 Hz to 13.2 GHz, characteristic |
| <i>(Option UKB)</i> | 100 Hz to 13.2 GHz | |
| ac Coupled | 100 kHz to 13.2 GHz | |
| Band | | Harmonic Mixing Mode (N ^a) |
| 0 (0 Hz to 3.0 GHz) | | 1– |
| 1 (2.85 GHz to 6.7 GHz) | | 1– |
| 2 (6.2 GHz to 13.2 GHz) | | 2– |
| Preamp On <i>(Option IDS)</i> | 1 MHz to 3.0 GHz | |

- a. N is the harmonic mixing mode. For negative mixing modes (as indicated by the “–”), the desired 1st LO harmonic is higher than the tuned frequency by the 1st IF (3.9214 for the 9 kHz to 3 GHz band, 321.4 MHz for all other bands).

| | Specifications | Supplemental Information |
|----------------------------|------------------------------------|--|
| Frequency Reference | | |
| Aging Rate | $\pm 2 \times 10^{-6}/\text{year}$ | $\pm 1.0 \times 10^{-7}/\text{day}$, characteristic |
| Settability | $\pm 5 \times 10^{-7}$ | |
| Temperature Stability | $\pm 5 \times 10^{-6}$ | |

| | Specifications | Supplemental Information |
|---|------------------------------------|--|
| High Stability Frequency Reference <i>(Option ID5)</i> | | |
| Aging Rate | $\pm 1 \times 10^{-7}/\text{year}$ | $\pm 5 \times 10^{-10}/\text{day}$, 7-day average after being powered on for 7 days, characteristic |
| Settability | $\pm 1 \times 10^{-8}$ | |
| Temperature Stability | | |
| 20 to 30 °C | $\pm 1 \times 10^{-8}$ | |
| 0 to 55 °C | $\pm 5 \times 10^{-8}$ | |

| | Specifications | Supplemental Information |
|---|----------------|--|
| Warm-up (Internal frequency reference selected) | | |
| After 5 minutes | | $< \pm 1 \times 10^{-7}$ of final frequency, ^a characteristic |
| After 15 minutes | | $< \pm 1 \times 10^{-8}$ of final frequency, ^a characteristic |

a. Final frequency is defined as frequency 60 minutes after power-on with analyzer set to internal frequency reference.

| | Specifications | Supplemental Information |
|--|--|--------------------------|
| Frequency Readout Accuracy (Start, Stop, Center, Marker) | $\pm((\text{frequency indication} \times \text{frequency reference error}^{\text{a}})$ $+ 0.5\% \text{ of span}$ $+ \frac{\text{span}}{\text{sweep points} - 1}$ $+ 15\% \text{ of RBW}$ $+ 10 \text{ Hz} + 1 \text{ Hz} \times N^{\text{b}})$ | |

a. Frequency reference error = (aging rate \times period of time since adjustment + settability + temperature stability).

b. N is the harmonic mixing mode.

| | Specifications | Supplemental Information |
|---------------------------------|--|--------------------------|
| Marker Frequency Counter | | |
| Resolution | Selectable from 1 Hz to 100 kHz | |
| Accuracy ^a | $\pm(\text{marker frequency} \times \text{frequency reference error}^{\text{b}} + \text{counter resolution})^{\text{c}}$ | For RBW \geq 1 kHz |

a. Marker level to displayed noise level $>$ 25 dB, RBW/ Span \geq 0.002, frequency offset = 0 Hz.

b. Frequency reference error = (aging rate \times period of time since adjustment + settability + temperature stability).

c. For firmware revisions prior to A.03.00, add 1 Hz \times N, where N is the harmonic mixing mode.

Agilent E4405B Specifications and Characteristics
Frequency

| | Specifications | Supplemental Information |
|-----------------------|---|--------------------------|
| Frequency Span | | |
| Range | 0 Hz (zero span), 100 Hz to 13.2 GHz | |
| Resolution | 2 Hz x N ^a | |
| Accuracy ^b | ±(0.5% of span + 2 × $\frac{\text{span}}{\text{sweep points} - 1}$) | |

- a. N is the harmonic mixing mode.
b. Applies to each sweep segment.

| | Specifications | Supplemental Information |
|---|--|---|
| Sweep Time | | |
| Range | | |
| Span > 0 Hz | 1 ms to 4000 s ^a | $\frac{\text{sweep points} - 1}{100 \text{ kHz}}$ to 4000 s |
| Span = 0 Hz | 10 μs to 4000 s ^{a,b} | |
| Tracking Generator On (Option 1DN) | | 50 ms is the minimum sweep time |
| Fast Time-domain Sweep (Option AYX) (For Span = 0 Hz, RBW ≥ 1 kHz) | 50 ns to 4000 s ^{c,d} | $\frac{\text{sweep points} - 1}{20 \text{ MHz}}$ to 4000 s |
| DSP and fast ADC (Option B7D) (For Span = 0 Hz, RBW ≥ 1 kHz) | 25 ns to 4000 s ^e | $\frac{\text{sweep points} - 1}{40 \text{ MHz}}$ to 4000 s |
| Accuracy (Span = 0 Hz) | | |
| 10 μs to 4000 s ^{a,b} | ±1% | |
| (Option AYX) | ±1% | |
| 50 ns to 4000 s ^{c,d} | | |
| (Option B7D) | ±1% | |
| 25 ns to 4000 s ^e | | |
| Sweep Trigger ^{f,g} | Free Run, Single, Line, Video ^h , External, Delayed, Offset ⁱ | |
| (Option 1D6) | Add Gate | |
| (Option B7B) | Add TV | |
| (Option B7E) | Add Burst Carrier Trigger | |

| | Specifications | Supplemental Information |
|--|---|--|
| Delayed Trigger ^{g,j} | | |
| Range | 1 μs to 400 s | |
| Resolution | $\frac{\text{delay in seconds}}{65000}$ rounded up to nearest μs | |
| Accuracy | ±(500 ns + (0.01% of delay)) | |
| Offset Trigger ⁱ | | |
| Resolution | $\frac{\text{sweep time}}{\text{sweep points} - 1}$ | |
| Range | ±327 ms to ±12.3 ks | Where ST = sweep time and SP = sweep points $\frac{-32766 \times ST}{SP - 1}$ to $\frac{(32766 - SP) \times ST}{SP - 1}$ |
| Fast Time-domain sweep (Option AYX) (For sweep times $\frac{\text{sweep points} - 1}{20 \text{ MHz}}$ to $\frac{\text{sweep points} - 1}{100 \text{ kHz}}$) | ±1.23 ms to ±245 ms | $\frac{-32766 \times ST}{SP - 1}$ to $\frac{(32766 - SP) \times ST}{SP - 1}$ |
| DSP and fast ADC (Option B7D) (For sweep times $\frac{\text{sweep points} - 1}{40 \text{ MHz}}$ to $\frac{\text{sweep points} - 1}{100 \text{ kHz}}$) | ± 13 ms to ±5.15 s | $\frac{-524031 \times ST}{SP - 1}$ to $\frac{(524031 - SP) \times ST}{SP - 1}$ |

- a. For firmware revisions prior to A.04.00, 5 ms to 2000 s.
- b. For firmware revisions prior to A.05.00, 1 ms to 4000 s.
- c. For firmware revisions prior to A.04.00, 20 μs to 2000 s.
- d. For firmware revisions prior to A.05.00, 5 μs to 4000 s.
- e. For firmware revisions prior to A.05.00, 2.5 μs to 4000 s.
- f. Gate cannot be used simultaneously with delayed or TV trigger (Option B7B).
- g. Auto align is suspended in video, external, gate, and delayed trigger modes while waiting for a trigger event to occur.
- h. Unavailable when RBW ≤ 300 Hz (Option IDR).
- i. For firmware revision A.04.00 or later.
- j. Delayed trigger is available with line, external trigger, and TV trigger (Option B7B).

Agilent E4405B Specifications and Characteristics
Frequency

| | Specifications | Supplemental Information |
|-----------------------------|--------------------------|--------------------------|
| Sweep (trace) Points | | |
| Range | | |
| Span > 0 Hz | 101 to 8192 ^a | |
| Span = 0 Hz | 2 to 8192 ^{a,b} | |

- a. For firmware revisions prior to A.04.00, 401 points.
b. For firmware revisions prior to A.05.00, 101 to 8192 points.

| | Specifications | Supplemental Information |
|--|---|---|
| Resolution Bandwidth (RBW) | | |
| Range | | |
| -3 dB bandwidth | 1 kHz to 3 MHz, in 1-3-10 sequence, 5 MHz | |
| -6 dB bandwidth (EMI) | 9 kHz and 120 kHz | |
| <i>(Option IDR)</i> | | |
| -3 dB bandwidth | Adds 10, 30, 100, 300 Hz | Only available in spans ≤ 5 MHz, sweep times ≥ $\frac{\text{sweep points} - 1}{100 \text{ kHz}}$, and not usable with tracking generator on. <i>(Option IDN)</i> |
| -6 dB bandwidth (EMI) | Add 200 Hz | |
| Accuracy | | |
| 1 kHz to 3 MHz RBW | ±15% | |
| 5 MHz RBW | ±30% | |
| Shape | | |
| 1 kHz to 5 MHz RBW | | Synchronously tuned four poles, approximately Gaussian shape |
| 10 Hz to 300 Hz RBW <i>(Option IDR)</i> | | Digital, approximately Gaussian shape |
| Selectivity (60 dB/3 dB bandwidth ratio) | | |
| 1 kHz to 5 MHz RBW | | <15:1, characteristic |
| 10 Hz to 300 Hz RBW <i>(Option IDR)</i> | | <5:1, characteristic |

| | Specifications | Supplemental Information |
|--------------------------------------|-----------------------------------|--|
| Video Bandwidth (VBW) (-3 dB) | | |
| Range | 30 Hz to 1 MHz in 1-3-10 sequence | 3 MHz, characteristic |
| (Option 1DR) | Adds 1, 3, 10 Hz for RBW's <1 kHz | |
| Accuracy | | ±30%, characteristic |
| Shape | | Post detection, single pole low-pass filter used to average displayed noise Video bandwidths below 30 Hz are digital bandwidths with anti-aliasing filtering. |

| | Specifications | Supplemental Information |
|--|----------------------------|--------------------------------------|
| Stability | | |
| Noise Sidebands (Offset from CW signal with 1 kHz RBW, 30 Hz VBW and sample detector) | | |
| ≥1 kHz (Option 1DR, 1D5) | | ≤ -78 dBc/Hz ^a , typical |
| ≥10 kHz | ≤ -90 dBc/Hz ^a | ≤ -94 dBc/Hz ^a , typical |
| ≥20 kHz | ≤ -100 dBc/Hz ^a | ≤ -105 dBc/Hz ^a , typical |
| ≥30 kHz | ≤ -106 dBc/Hz ^a | ≤ -112 dBc/Hz ^a , typical |
| ≥100 kHz | ≤ -119 dBc/Hz ^a | ≤ -122 dBc/Hz ^a , typical |
| ≥1 MHz | ≤ -125 dBc/Hz ^a | ≤ -127 dBc/Hz ^a , typical |
| ≥5 MHz | ≤ -127 dBc/Hz ^a | ≤ -129 dBc/Hz ^a , typical |
| ≥10 MHz | ≤ -131 dBc/Hz ^a | ≤ -136 dBc/Hz ^a , typical |
| (Option 120) | | |
| ≥1 MHz | ≤ -133 dBc/Hz ^a | ≤ -136 dBc/Hz, typical |
| ≥5 MHz | ≤ -135 dBc/Hz ^a | ≤ -139 dBc/Hz, typical |
| ≥10 MHz | ≤ -137 dBc/Hz ^a | ≤ -141 dBc/Hz, typical |

Agilent E4405B Specifications and Characteristics
Frequency

| | Specifications | Supplemental Information |
|--|---|---|
| Residual FM | | |
| 1 kHz RBW, 1 kHz VBW (Option 1D5) | $\leq 150 \text{ Hz} \times N \text{ p-p in } 100 \text{ ms}$ | |
| 10 Hz RBW, 10 Hz VBW (Option 1DR and 1D5) | $\leq 100 \text{ Hz} \times N \text{ p-p in } 100 \text{ ms}$ | |
| 10 Hz RBW, 10 Hz VBW (Option 1DR) | $\leq 2 \text{ Hz} \times N \text{ p-p in } 20 \text{ ms}$ | $\leq 10 \text{ Hz} \times N \text{ p-p in } 20 \text{ ms, characteristic}$ |
| System-Related Sidebands, offset from CW signal | | |
| $\geq 30 \text{ kHz}$ | $\leq -65 \text{ dBc}^a$ | |
| Line-Related Sidebands, offset from CW signal (Option 1DR) | | |
| $< 300 \text{ Hz}$ | | $\leq -50 \text{ dBc}^a, \text{ characteristic}$ |
| $> 300 \text{ Hz to } 30 \text{ kHz}$ | | $\leq -55 \text{ dBc}^a, \text{ characteristic}$ |

a. Add $20 \text{ Log}(N)$ for frequencies $> 6.7 \text{ GHz}$.

Noise Sidebands Normalized to 1 Hz Versus Offset from Carrier

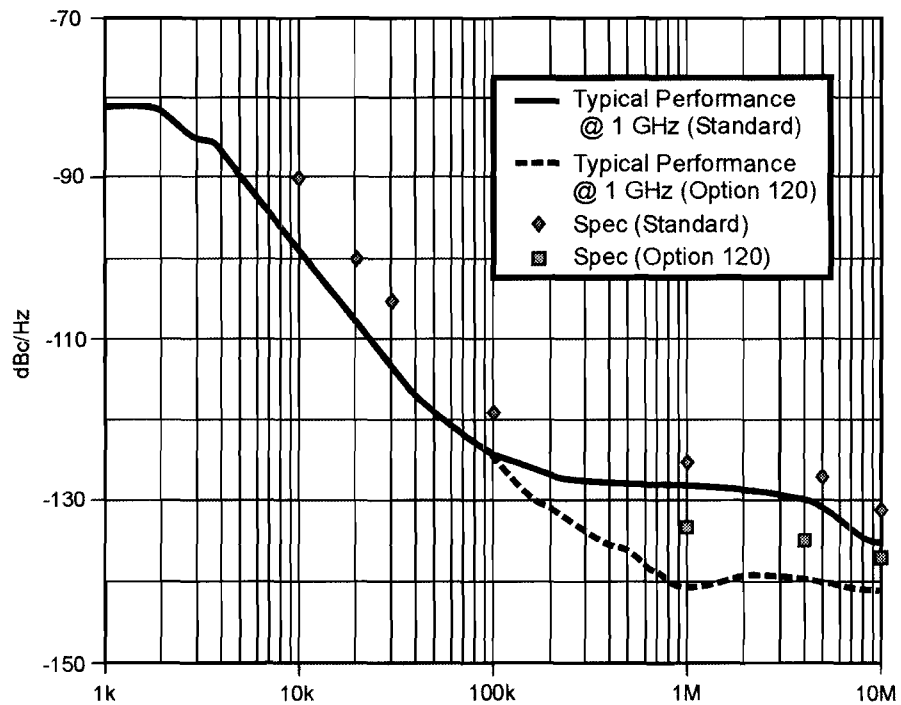

w722b

Amplitude

Amplitude specifications do not apply for the negative peak detector mode.

| | Specifications | Supplemental Information |
|--------------------------|---|---|
| Measurement Range | Displayed Average Noise Level to Maximum Safe Input Level | |
| Input Attenuator Range | 0 to 65 dB, in 5 dB steps | 0 to 75 dB, in 5 dB steps, characteristic |

| | Specifications | Supplemental Information |
|--|-----------------|--------------------------|
| Maximum Safe Input Level | | |
| Average Continuous Power (Input attenuator setting ≥ 5 dB) | +30 dBm (1 W) | |
| Peak Pulse Power (for < 10 μ sec pulse width, $< 1\%$ duty cycle, and input attenuation ≥ 30 dB) | +50 dBm (100 W) | |
| dc | | |
| dc Coupled | 0 Vdc | |
| ac Coupled | 50 Vdc | |

| | Specifications | Supplemental Information |
|---|----------------|--------------------------|
| 1 dB Gain Compression | | |
| Total power at input mixer ^{a,b} | | |
| 50 MHz to 3.0 GHz | 0 dBm | |
| 3.0 GHz to 6.7 GHz | 0 dBm | |
| 6.7 GHz to 13.2 GHz | -3 dBm | |
| Preamp On (<i>Option IDS</i>) | | |
| Total power at the preamp ^c | | -20 dBm, characteristic |

a. Mixer power level (dBm) = input power (dBm) – input attenuation (dB).

b. For resolution bandwidths 1 kHz to 30 kHz, the maximum input signal amplitude must be \leq reference level +10 dB.

c. Total power at the preamp (dBm) = total power at the input (dBm) – input attenuation (dB).

| | Specifications | | Supplemental Information | |
|--|------------------------|---------------------------------------|-------------------------------------|---|
| | | | | |
| Displayed Average Noise Level (Input terminated, 0 dB attenuation, sample detector, Reference Level = -70 dBm) | | | | |
| | 1 kHz RBW 30 Hz VBW | 10 Hz RBW 1 Hz VBW (Option IDR) | 1 kHz RBW 30 Hz VBW (typical) | 10 Hz RBW 1 Hz VBW (Option IDR) (typical) |
| 30 Hz to 9 kHz (Option UKB) | | | | ≤ -93 dBm |
| 9 kHz to 100 kHz | | | | ≤ -109 dBm |
| 100 kHz to 1 MHz | | | | ≤ -135 dBm |
| 1 MHz to 10 MHz | | | ≤ -117 dBm | ≤ -137 dBm |
| 1 MHz to 10 MHz (Option 120) | | | ≤ -120 dBm | ≤ -139 dBm |
| 10 MHz to 1.0 GHz | ≤ -116 dBm | ≤ -135 dBm | ≤ -119 dBm | ≤ -139 dBm |
| 1.0 GHz to 2.0 GHz | ≤ -116 dBm | ≤ -135 dBm | ≤ -120 dBm | ≤ -140 dBm |
| 2.0 GHz to 3.0 GHz | ≤ -112 dBm | ≤ -131 dBm | ≤ -118 dBm | ≤ -138 dBm |
| 3.0 GHz to 6.0 GHz | ≤ -112 dBm | ≤ -131 dBm | ≤ -118 dBm | ≤ -138 dBm |
| 6.0 GHz to 12 GHz | ≤ -111 dBm | ≤ -130 dBm | ≤ -117 dBm | ≤ -137 dBm |
| 12 GHz to 13.2 GHz | ≤ -107 dBm | ≤ -126 dBm | ≤ -114 dBm | ≤ -134 dBm |
| Preamp On (Option IDS) | 1 kHz RBW 30 Hz VBW | 10 Hz RBW 1 Hz VBW (Option IDR) | 1 kHz RBW 30 Hz VBW (typical) | 10 kHz RBW 1 Hz VBW (Option IDR) (typical) |
| 0 to 55 °C | | | | |
| 10 MHz to 1.0 GHz | ≤ -131 dBm | ≤ -150 dBm | | |
| 1.0 GHz to 2.0 GHz | ≤ -131 dBm | ≤ -150 dBm | | |
| 2.0 GHz to 3.0 GHz | ≤ -127 dBm | ≤ -146 dBm | | |
| 20 to 30 °C | | | | |
| 1 MHz to 10 MHz | | | ≤ -135 dBm | ≤ -155 dBm |
| 10 MHz to 1.0 GHz | ≤ -132 dBm | ≤ -151 dBm | ≤ -137 dBm | ≤ -157 dBm |
| 1.0 GHz to 2.0 GHz | ≤ -132 dBm | ≤ -151 dBm | ≤ -135 dBm | ≤ -155 dBm |
| 2.0 GHz to 3.0 GHz | ≤ -130 dBm | ≤ -149 dBm | ≤ -132 dBm | ≤ -152 dBm |

| | Specifications | Supplemental Information |
|---|---|---------------------------------|
| Display Range | | |
| Log Scale | Ten divisions displayed; 0.1, 0.2, 0.5 dB/division and 1 to 20 dB/division in 1 dB steps | |
| RBW \geq 1 kHz | Calibrated 0 to -85 dB from Reference Level | |
| RBW \leq 300 Hz (<i>Option IDR</i>) | Calibrated 0 to -120 dB ^a from Reference Level | |
| Linear Scale | Ten divisions | |
| Scale Units | dBm, dBmV, dB μ V, dB μ A, A, V, and W | |
| (<i>Option BAA, 106</i>) | Add Hz | |

- a. 0 to -70 dB range when span = 0 Hz, or when IF Gain fixed:
(:DISPlay:WINDow:TRACe:Y[:SCALe]:LOG:RANGe:AUTO OFF).

| | Specifications | Supplemental Information |
|---|--|---------------------------------|
| Marker Readout Resolution | | |
| Log scale | | |
| RBW \geq 1 kHz | | |
| 0 to -85 dB from ref level | 0.04 dB | |
| RBW \leq 300 Hz (<i>Option IDR</i>) | | |
| 0 to -120 dB from ref level | 0.04 dB | |
| Linear scale | 0.01% of Reference Level | |
| Fast Sweep Times for Zero Span | | |
| (<i>Option AYX</i>) | | |
| For sweep times | | |
| $\frac{\text{sweep points} - 1}{20 \text{ MHz}}$ to | | |
| $\frac{\text{sweep points} - 1}{100 \text{ kHz}}$ | | |
| Log | | |
| 0 to -85 dB from ref level | 0.3 dB | |
| Linear | 0.3% of Reference Level for linear scale | |

| | Specifications | Supplemental Information |
|---|--|--------------------------|
| (Option B7D) For sweep times $\frac{\text{sweep points} - 1}{40 \text{ MHz}}$ $\frac{\text{sweep points} - 1}{100 \text{ kHz}}$ Log 0 to -85 dB from ref level Linear | 0.2 dB 0.2% of Reference Level for linear scale | |

| | Specifications | Supplemental Information |
|--|---|---|
| Frequency Response 50 Ω , Absolute ^a /Relative 10 dB attenuation (dc coupled) 9 kHz to 3.0 GHz 20 to 30 °C 0 to 55 °C (ac coupled) 100 kHz to 3.0 GHz 20 to 30 °C 0 to 55 °C 800 MHz to 1.0 GHz ^b 20 to 30 °C 0 to 55 °C 1.7 GHz to 2.0 GHz 20 to 30 °C 0 to 55 °C | ±0.46 dB ±0.76 dB ±0.50 dB ±1.0 dB ±0.50 dB ±1.0 dB ±0.50 dB ±1.0 dB | ±0.14 dB, typical ±0.10 dB, typical ±0.08 dB, typical |

Agilent E4405B Specifications and Characteristics
Amplitude

| | Specifications | Supplemental Information |
|---|----------------|--------------------------|
| <i>(Option UKB)</i> | | |
| 100 Hz to 3.0 GHz (dc coupled) | | |
| 20 to 30 °C | ±0.50 dB | |
| 0 to 55 °C | ±1.00 dB | |
| 30 Hz to 3.0 GHz (dc coupled) | | |
| 20 to 30 °C | | ±0.5 dB, characteristic |
| 0 to 55 °C | | ±1.0 dB, characteristic |
| Absolute ^a /Relative, Preamp On <i>(Option IDS)</i> | | |
| 0 dB attenuation | | |
| 1 MHz to 3.0 GHz | | |
| 20 to 30 °C | ±1.5 dB | |
| 0 to 55 °C | ±2.0 dB | |
| 800 MHz to 1.0 GHz | | |
| 20 to 30 °C | ±1.5 dB | ±0.35 dB, typical |
| 0 to 55 °C | ±2.0 dB | |
| 1.7 GHz to 2.0 GHz | | |
| 20 to 30 °C | ±1.5 dB | ±0.26 dB, typical |
| 0 to 55 °C | ±2.0 dB | |
| Preselector centered for frequency >3.0 GHz | | |
| 10 dB attenuation | | |
| 3.0 GHz to 6.7 GHz (ac or dc coupled) | | |
| Absolute ^a | | |
| 20 to 30 °C | ±1.5 dB | |
| 0 to 55 °C | ±2.5 dB | |
| Relative | | |
| 20 to 30 °C | ±1.3 dB | |
| 0 to 55 °C | ±1.5 dB | |

| | Specifications | Supplemental Information |
|---|----------------|--------------------------|
| 6.7 GHz to 13.2 GHz (ac or dc coupled) | | |
| Absolute ^a | | |
| 20 to 30 °C | ±2.0 dB | |
| 0 to 55 °C | ±3.0 dB | |
| Relative | | |
| 20 to 30 °C | ±1.8 dB | |
| 0 to 55 °C | ±2.0 dB | |

a. Absolute frequency response values are referenced to the amplitude at 50 MHz.

b. This specification applies only to analyzers with serial numbers ≥ US39440327.

| | Specifications | Supplemental Information |
|--|--|--------------------------|
| Input Attenuation Switching Uncertainty at 50 MHz | | |
| Attenuator Setting | | |
| 0 dB to 5 dB | ±0.3 dB | |
| 10 dB | Reference | |
| 15 dB | ±0.3 dB | |
| 20 to 65 dB attenuation | ±(0.1 dB + 0.01 × Attenuator Setting) | |

| Attenuation Accuracy Relative to the 10 dB Attenuator Setting, Characteristic | | |
|---|-----------------|--------------|
| | Frequency Range | |
| Attenuation | dc–3.0 GHz | 3.0–13.2 GHz |
| 0 dB | ±0.3 dB | ±0.5 dB |
| 5 dB | ±0.3 dB | ±0.5 |
| 10 dB | Reference | Reference |
| 15 dB | ±0.4 dB | ±0.5 dB |
| 20 dB | ±0.4 dB | ±0.5 dB |
| 25 dB | ±0.5 dB | ±0.6 dB |
| 30 dB | ±0.5 dB | ±0.6 dB |
| 35 dB | ±0.6 dB | ±0.7 dB |

| Attenuation Accuracy Relative to the 10 dB Attenuator Setting, Characteristic | | |
|--|------------------------|---------------------|
| | Frequency Range | |
| Attenuation | dc–3.0 GHz | 3.0–13.2 GHz |
| 40 dB | ±0.6 dB | ±0.7 dB |
| 45 dB | ±0.7 dB | ±1.0 dB |
| 50 dB | ±0.7 dB | ±1.0 dB |
| 55 dB | ±0.9 dB | ±1.1 dB |
| 60 dB | ±0.9 dB | ±1.1 dB |
| 65 dB | ±1.0 dB | ±1.6 dB |

| | Specifications | Supplemental Information |
|-------------------------------------|-----------------------|---|
| Preamp (<i>Option 1DS</i>) | | Refer also to Displayed Average Noise Level specification |
| Gain | | +20 dB, nominal ^a |
| Noise figure | | 5 dB, characteristic |

a. Amplifier is between the input attenuator and the input mixer.

| | Specifications | Supplemental Information |
|---|---|---------------------------------|
| Absolute Amplitude Accuracy | | |
| At reference settings ^a | ±0.34 dB | ±0.13 dB, typical |
| Preamp On ^b (<i>Option 1DS</i>) | ±0.37 dB | ±0.14 dB, typical |
| Overall Amplitude Accuracy^c | | |
| 20 to 30 °C | ± (0.54 dB + Absolute Frequency Response) | |

- Settings are: reference level –20 dBm; input attenuation 10 dB; dc coupled; center frequency 50 MHz; RBW 1 kHz; VBW 1 kHz; scale linear or log; span 2 kHz; sweep time coupled, sample detector, signal at reference level.
- Settings are: reference level –30 dBm; input attenuation 0 dB; dc coupled; center frequency 50 MHz; RBW 1 kHz; VBW 1 kHz; scale linear or log; span 2 kHz; sweep time coupled, signal at reference level.
- For reference level 0 to –50 dBm; input attenuation 10 dB; dc coupled; RBW 1 kHz; VBW 1 kHz; scale log, log range 0 to –50 dB from reference level; sweep time coupled; signal input 0 to –50 dBm; span ≤20 kHz.

| | Specifications | Supplemental Information | | |
|---|----------------|-----------------------------------|----------------|--------------|
| RF Input VSWR (at tuned frequency) | | characteristic | characteristic | |
| | | Attenuator setting 0 dB | (dc coupled) | (ac coupled) |
| | | 9 kHz to 100 kHz | $\leq 3.0:1$ | |
| | | 100 kHz to 13.2 GHz | $\leq 3.0:1$ | $\leq 3.0:1$ |
| | | 100 Hz to 100 kHz (Option UKB) | $\leq 1.1:1$ | |
| | | Attenuator setting 5 dB | (dc coupled) | (ac coupled) |
| | | 9 kHz to 100 kHz | $\leq 2.0:1$ | |
| | | 100 kHz to 300 kHz | $\leq 1.4:1$ | $\leq 2.3:1$ |
| | | 300 kHz to 1.0 MHz | $\leq 1.4:1$ | $\leq 1.6:1$ |
| | | 1.0 MHz to 3.0 GHz | $\leq 1.4:1$ | $\leq 1.4:1$ |
| | | 3.0 GHz to 6.7 GHz | $\leq 1.4:1$ | $\leq 1.7:1$ |
| | | 6.7 GHz to 13.2 GHz | $\leq 1.7:1$ | $\leq 1.9:1$ |
| | | 100 Hz to 100 kHz (Option UKB) | $\leq 1.1:1$ | |
| | | Attenuator setting 10 to 65 dB | (dc coupled) | (ac coupled) |
| | | 9 kHz to 100 kHz | $\leq 2.0:1$ | |
| | | 100 kHz to 300 kHz | $\leq 1.3:1$ | $\leq 2.1:1$ |
| | | 300 kHz to 1.0 MHz | $\leq 1.3:1$ | $\leq 1.5:1$ |
| | | 1.0 MHz to 3.0 GHz | $\leq 1.3:1$ | $\leq 1.3:1$ |
| 3.0 GHz to 6.7 GHz | $\leq 1.3:1$ | $\leq 1.5:1$ | | |
| 6.7 GHz to 13.2 GHz | $\leq 1.5:1$ | $\leq 1.7:1$ | | |
| 100 Hz to 100 kHz (Option UKB) | $\leq 1.1:1$ | | | |

| | Specifications | Supplemental Information |
|-----------------------------------|----------------|------------------------------|
| Auto Alignment^a | | |
| Sweep-to-sweep variation | | ± 0.1 dB, characteristic |

a. Set **Auto Align** to **Off** and use **Align Now, All** to eliminate this variation.

Agilent E4405B Specifications and Characteristics
Amplitude

| | Specifications | Supplemental Information |
|--|----------------|--------------------------|
| Resolution Bandwidth Switching Uncertainty (at Reference Level) | | |
| 1 kHz RBW | Reference | |
| 3 kHz to 3 MHz RBW | ± 0.3 dB | |
| 5 MHz RBW | ± 0.6 dB | |
| 10 Hz to 300 Hz RBW (Option IDR) | ± 0.3 dB | |

| | Specifications | Supplemental Information |
|--|--|--------------------------|
| Reference Level | | |
| Range | -149.9 dBm to maximum mixer level + attenuator setting | |
| Resolution | | |
| Log Scale | ± 0.1 dB | |
| Linear Scale | $\pm 0.12\%$ of Reference Level | |
| Accuracy (at a fixed frequency, a fixed attenuator, and referenced to -30 dBm (-10 dBm, Preamp On (Option IDS))) | | |
| Reference Level (dBm) – input attenuator setting (dB) + preamp gain (dB) | | |
| -10 dBm to > -60 dBm | ± 0.3 dB | |
| -60 dBm to > -85 dBm | ± 0.5 dB | |
| -85 dBm to -90 dBm | ± 0.7 dB | |

| | Specifications | Supplemental Information |
|--|----------------------------------|--------------------------|
| Display Scale Switching Uncertainty | | |
| Switching between Linear and Log | ± 0.15 dB at reference level | |
| Log Scale Switching | No error | |

| | Specifications | Supplemental Information |
|---|---|------------------------------|
| Display Scale Fidelity | | |
| Log Maximum Cumulative | | |
| RBW \geq 1 kHz | | |
| dB Below Reference Level | | |
| 0 dB Reference | 0 dB | |
| > 0 to 10 dB | ± 0.22 dB | ± 0.08 dB, typical |
| > 10 to 20 dB | ± 0.24 dB | ± 0.09 dB, typical |
| > 20 to 30 dB | ± 0.26 dB | ± 0.10 dB, typical |
| > 30 to 40 dB | ± 0.40 dB | ± 0.23 dB, typical |
| > 40 to 50 dB | ± 0.57 dB | ± 0.35 dB, typical |
| > 50 to 60 dB | ± 0.57 dB | ± 0.35 dB, typical |
| > 60 to 70 dB | ± 0.66 dB | ± 0.39 dB, typical |
| > 70 to 80 dB | ± 0.66 dB | ± 0.46 dB, typical |
| > 80 to 85 dB | ± 1.15 dB | ± 0.79 dB, typical |
| RBW \leq 300 Hz (<i>Option 1DR</i>) | | |
| Span > 0 Hz | | |
| Auto range On | | |
| 0 to 98 dB below reference level | $\pm(0.3 \text{ dB} + 0.01 \times \text{dB from reference level})$ | |
| > 98 to 120 dB below reference level | | ± 2.0 dB, characteristic |
| Auto range Off | | |
| 0 to 60 dB below reference level | $\pm(0.3 \text{ dB} + 0.015 \times \text{dB from reference level})$ | |
| > 60 to 70 dB below reference level | ± 1.5 dB | |
| Span = 0 Hz ^a | | |
| 0 to 60 dB below reference level | $\pm(0.3 \text{ dB} + 0.015 \times \text{dB from reference level})$ | |
| > 60 to 70 dB below reference level | ± 1.5 dB | |

| | Specifications | Supplemental Information |
|---|------------------------|--------------------------|
| Log Incremental Accuracy | | |
| 0 to 80 dB ^b below reference level | ±0.4 dB/4 dB | |
| Linear Accuracy | ±2% of Reference Level | |

- a. The SCPI command for auto range off is:
(:DISPlay:WINDow:TRACe:Y[:SCALE]:LOG:RANGE:AUTO OFF)
- b. 0 to -50 dB for RBWs ≤ 300 Hz and span = 0 Hz, or when auto ranging is off.

| | Specifications | Supplemental Information |
|--|--|--|
| Spurious Responses | | |
| Second Harmonic Distortion | | |
| Input Signal | | |
| 10 MHz to 500 MHz | < -65 dBc for -30 dBm signal at input mixer ^a | +35 dBm SHI (second harmonic intercept) |
| 500 MHz to 1.5 GHz | < -75 dBc for -30 dBm signal at input mixer ^a | +45 dBm SHI |
| 1.5 GHz to 2.0 GHz | < -85 dBc for -10 dBm signal at input mixer ^a | +75 dBm SHI |
| 2.0 GHz to 3.35 GHz | < -100 dBc ^b for -10 dBm signal at input mixer ^a | +90 dBm SHI |
| 3.35 GHz to 6.6 GHz | < -100 dBc ^b for -10 dBm signal at input mixer ^a | +90 dBm SHI |
| Preamp On (<i>Option IDS</i>) 10 MHz to 1.5 GHz | | -5 dBm SHI, characteristic |
| Third Order Intermodulation Distortion | | |
| 10 MHz to 100 MHz | | +7 dBm TOI (third order intercept), characteristic |
| 100 MHz to 3 GHz | < -85 dBc for two -30 dBm signals at input mixer ^a and >50 kHz separation | +12.5 dBm TOI +16 dBm TOI, typical |
| 3.0 GHz to 6.7 GHz | < -82 dBc for two -30 dBm signals at input mixer ^a and >50 kHz separation | +11 dBm TOI +18 dBm TOI, typical |

| | Specifications | Supplemental Information |
|--|--|--------------------------------------|
| 6.7 GHz to 13.2 GHz | < -75 dBc for two -30 dBm signals at input mixer ^a and >50 kHz separation | +7.5 dBm TOI +12 dBm TOI, typical |
| Preamp On (<i>Option 1DS</i>) 10 MHz to 3 GHz | | -16 dBm TOI, characteristic |
| Other Input Related Spurious | | |
| Inband Responses | | |
| >30 kHz offset | < -65 dBc for -20 dBm signal at input mixer ^a | |
| Out-of-band Responses | < -80 dBc for -10 dBm signal at input mixer ^a | |

- a. Mixer power level (dBm) = input power (dBm) – input attenuation (dB).
b. or signal below displayed average noise level.

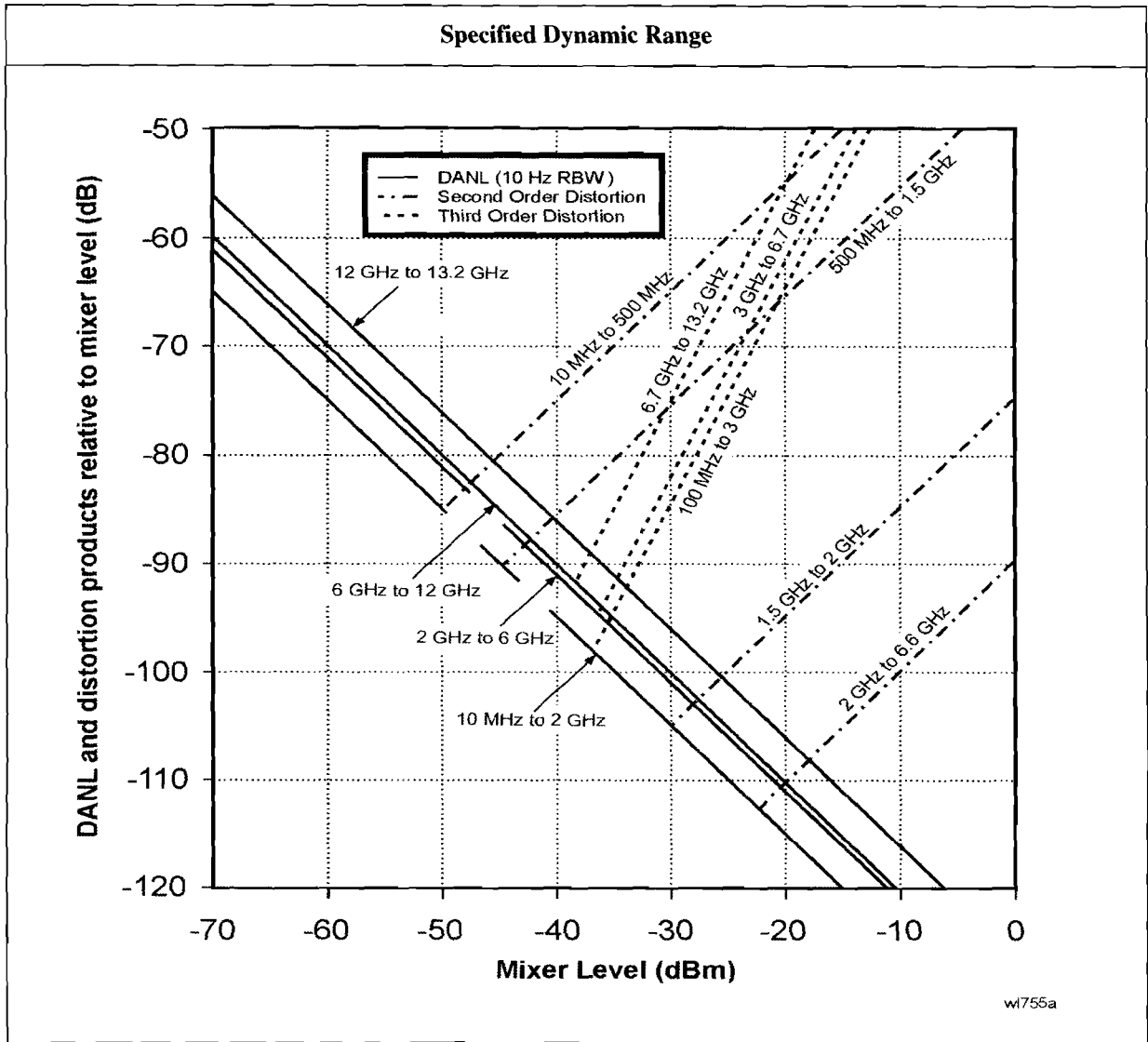

| | Specifications | Supplemental Information |
|---|----------------|--------------------------|
| Residual Responses (Input terminated and 0 dB attenuation) 150 kHz to 6.7 GHz | < -90 dBm | |

Options

Time Gated Spectrum Analysis (Option 1D6)

| | Specifications | Supplemental Information |
|---|---|---|
| Gate Delay | | |
| Range | 1 μ s to 400 s | |
| Accuracy | $\pm(500 \text{ ns} + (0.01\% \times (\text{maximum of gate delay or length})))$ | From gate trigger input to positive edge of gate output |
| Gate Length | | |
| Range | 1 μ s to 400 s | |
| Accuracy | $\pm(500 \text{ ns} + (0.01\% \times (\text{maximum of gate delay or length})))$ | From positive edge to negative edge of gate output |
| Resolution | $((\text{maximum of gate delay or length in seconds})/65000)$ rounded up to nearest μ s | Dependent on the greater of gate delay or gate length |
| Additional Amplitude Error^a | | |
| Log Scale | $\pm 0.2 \text{ dB}$ | |
| Linear Scale | $\pm 0.1\%$ of reference level | |

a. While in gate mode.

Tracking Generator (Option 1DN)

The spectrum analyzer/tracking generator combination will meet its specification after a cable (8120-5148) and adapter are connected between RF OUT and INPUT and **Align Now, TG** has been run.

| | Specifications | Supplemental Information |
|----------------|----------------|--------------------------|
| Warm-up | 5 minutes | |

| | Specifications | Supplemental Information |
|-------------------------------|------------------|--------------------------|
| Output Frequency Range | 9 kHz to 3.0 GHz | |

| | Specifications | Supplemental Information |
|------------------------------|----------------|--|
| Minimum Resolution BW | 1 kHz | Not usable with resolution bandwidths ≤ 300 Hz (<i>Option 1DR</i>) |

| | Specifications | Supplemental Information |
|---|--------------------------|--------------------------|
| Output Power Level | | |
| Range | -2 to -66 dBm | |
| Resolution | 0.1 dB | |
| Absolute Accuracy (at 50 MHz with coupled source attenuator, referenced to -20 dBm) | ± 0.75 dB | |
| Vernier | | |
| Range | 8 dB | |
| Accuracy (with coupled source attenuator, 50 MHz, -20 dBm) | | |
| Incremental | ± 0.2 dB/dB | |
| Cumulative | ± 0.5 dB, total | |
| Output Attenuator Range | 0 to 56 dB in 8 dB steps | |

| | Specifications | Supplemental Information |
|-----------------------------------|----------------|---------------------------------------|
| Maximum Safe Reverse Level | | +30 dBm (1 W), 50 Vdc, characteristic |

| | Specifications | Supplemental Information |
|---------------------------|---|--------------------------|
| Output Power Sweep | | |
| Range | (-10 to -2 dBm) – (Source Attenuator Setting) | |
| Resolution | 0.1 dB | |
| Accuracy (zero span) | <1 dB peak-to-peak | |

| | Specifications | Supplemental Information |
|-------------------------------|----------------|--------------------------|
| Output Flatness | | |
| Referenced to 50 MHz, -20 dBm | | |
| 9 kHz to 10 MHz | ± 3 dB | |
| 10 MHz to 3 GHz | ± 2 dB | |

| | Specifications | Supplemental Information |
|----------------------------|----------------|--------------------------|
| Spurious Outputs | | |
| (-2 dBm output) | | |
| Harmonic Spurs | | |
| TG Output 9 kHz to 20 kHz | ≤ -15 dBc | |
| TG Output 20 kHz to 3 GHz | ≤ -25 dBc | |
| Non-harmonic Spurs | | |
| TG Output 9 kHz to 2 GHz | ≤ -27 dBc | |
| TG Output 2 GHz to 3 GHz | ≤ -23 dBc | |
| LO Feedthrough | | |
| LO Frequency | ≤ -16 dBm | |
| 3.921409 GHz to 6.9214 GHz | | |

| | Specifications | Supplemental Information |
|----------------------|--|--------------------------|
| Dynamic Range | Maximum Output Power Level – Displayed Average Noise Level | |

Agilent E4405B Specifications and Characteristics
Options

| | Specifications | Supplemental Information |
|---|----------------|--|
| Output Tracking Drift Swept Tracking Error | | 1.5 kHz/5 minute, characteristic Usable in 1 kHz RBW after 5 minutes of warm-up |

| | Specifications | Supplemental Information |
|---|----------------|----------------------------|
| RF Power-Off Residuals 9 kHz to 3 GHz | | < -120 dBm, characteristic |

| | Specifications | Supplemental Information |
|--|----------------|---|
| Output Attenuator Repeatability 9 kHz to 300 MHz 300 MHz to 2 GHz 2 GHz to 3 GHz | | ±0.1 dB, characteristic ±0.2 dB, characteristic ±0.3 dB, characteristic |

| | Specifications | Supplemental Information |
|--|----------------|--|
| Output VSWR 0 dB attenuation ≥ 8 dB attenuation | | <2.0:1, characteristic <1.5:1, characteristic |

| | Specifications | Supplemental Information |
|---|----------------|---|
| Output Attenuator Accuracy 0 dB 8 dB 16 dB 24 dB 32 dB 40 dB 48 dB 56 dB | Reference | ±0.5 dB, characteristic ±0.5 dB, characteristic ±0.5 dB, characteristic ±0.6 dB, characteristic ±0.8 dB, characteristic ±1.0 dB, characteristic ±1.1 dB, characteristic |

Tracking Generator Output Accuracy

Relative Accuracy (Referred to -20 dBm) =
Output Attenuator Accuracy + Vernier Accuracy + Output Flatness

Absolute Accuracy =
Relative Accuracy (Referred to -20 dBm) + Absolute Accuracy at 50 MHz

Bluetooth FM Demodulation (Option 106)

The FM demodulation characteristics will apply after an Align Now, FM Demod has been run.

| | Specifications | Supplemental Information |
|-----------------------------|----------------|---|
| Optimum Input Level | | $\geq (-40 \text{ dBm} + \text{attenuator setting} - \text{preamp gain})$ and within 10 dB of the reference level |
| FM Deviation | | |
| Range | | $\pm 200 \text{ kHz}$, nominal |
| Resolution | | Provides 400 Hz display annotation resolution, nominal |
| Accuracy ^a | | |
| Input level = -30 dBm | | $\pm 10 \text{ kHz}$, typical |
| Reference level = -30 dBm | | $\pm 4 \text{ kHz}$ with video averaging On and averages ≥ 25 |
| FM Rate = 500 kHz sine | | |
| VBW = 3 MHz, | | |
| RBW = 5 MHz, | | |
| FM Deviation = 140 kHz | | |
| Offset Error ^a | | $\pm 1 \text{ kHz}$, typical |
| FM Bandwidth (-3 dB) | | 1.2 MHz, nominal |

a. In time domain sweeps (span = 0 Hz).

Bluetooth Measurements Personality (Option 228)

The demodulation related nominals will apply after an Align Now, FM Demod has been run.

| | Specifications | Supplemental Information |
|--------------------------------|--------------------|--------------------------|
| In-Band Frequency Range | | |
| Bluetooth (ISM) Band | 2400 to 2483.5 MHz | |

| | Specifications | Supplemental Information |
|--|---|---|
| Output Power (Option AYX or B7D) | | |
| Range at RF Input | 30 to -40 dBm | |
| (Option IDS) | 30 to -60 dBm | |
| Absolute Amplitude Accuracy | | Appendix , "Absolute Amplitude Accuracy," on page 186 |
| Average type | Video, Power | |
| Average mode | Exponential, Repeat | |
| Trigger source | Video, RF burst ^a , External, Free Run | |
| Burst synch | RF Amplitude, Preamble ^b , None | |

a. Requires Option B7E

b. Requires Option 106 Bluetooth FM demodulation.

| | Specifications | Supplemental Information |
|--|---------------------------------|--|
| Modulation Characteristics^a (Option 106 and AYX or B7D) | | |
| Range at RF Input | 30 to -40 dBm | |
| (Option IDS) | 30 to -60 dBm | |
| FM Deviation | | |
| Range | | ±200 kHz, nominal |
| Accuracy | | ±4 kHz, nominal (25 measurement averages, signal level > -30 dBm) |
| Payload data | 11110000, 10101010, auto-detect | |
| Average mode | Exponential, Repeat | |

Agilent E4405B Specifications and Characteristics
Options

| | Specifications | Supplemental Information |
|----------------|--|--------------------------|
| Trigger source | Video, RF burst ^b , External, Free Run | |
| Burst synch | RF Amplitude, Preamble ^c , None | |
| Limits | $\Delta f_2/\Delta f_1$ lower, Δf_1 max lower/upper Δf_2 | |

- a. The DUT must have frequency hopping disabled.
- b. Requires Option B7E
- c. Requires Option 106 Bluetooth FM demodulation.

| | Specifications | Supplemental Information |
|--|---|---|
| Carrier Frequency Drift ^a (Option 106 and AYX or B7D) | | |
| Range at RF Input | 30 to -40 dBm | |
| (Option 1DS) | 30 to -60 dBm | |
| Measurement range | | ± 100 kHz, nominal |
| Measurement accuracy | | ± 4 kHz, nominal (25 measurement averages, signal level > -30 dBm) |
| Average mode | Exponential, Repeat | |
| Trigger source | Video, RF burst ^b , External, Free Run | |
| Burst synch | Preamble ^c , None | |

- a. The DUT must have frequency hopping disabled.
- b. Requires Option B7E
- c. Requires Option 106 Bluetooth FM demodulation.

| | Specifications | Supplemental Information |
|---|----------------|---|
| Initial Carrier Frequency Tolerance (ICTF) ^a (Option 106 and AYX or B7D) | | |
| Range at RF Input | 30 to -40 dBm | |
| (Option 1DS) | 30 to -60 dBm | |
| Measurement range | | ± 100 kHz, nominal |
| Measurement accuracy | | ± 4 kHz, nominal (25 measurement averages, signal level > -30 dBm) |

| | Specifications | Supplemental Information |
|----------------|---|--------------------------|
| Average mode | Exponential, Repeat | |
| Trigger source | Video, RF burst ^b , External, Free Run | |
| Burst synch | RF Amplitude, Preamble ^c , None | |
| Limits | ICFT upper/lower | |

- a. The DUT must have frequency hopping disabled.
- b. Requires Option B7E
- c. Requires Option 106 Bluetooth FM demodulation.

FM Demodulation (Option BAA)

The FM demodulation characteristics will apply after an **Align Now, FM Demod** has been run.

| | Specifications | Supplemental Information |
|---|----------------|---|
| Optimum Input Level | | $\geq (-60 \text{ dBm} + \text{attenuator setting} - \text{preamp gain})$ and within 30 dB of the reference level |
| FM Deviation | | |
| Range | | 10 kHz to 1 MHz |
| Resolution | | Provides 1 Hz display annotation resolution |
| FM Deviation Range | | |
| 10 kHz to 40 kHz | | 12 Hz, characteristic |
| >40 kHz to 200 kHz | | 60 Hz, characteristic |
| >200 kHz to 1 MHz | | 300 Hz, characteristic |
| Accuracy ^a | | |
| FM Rate < FM BW/100, VBW $\geq (30 \times \text{FM Rate})$, RBW > the maximum of (30 \times FM deviation) or (30 \times FM Rate) | | < (2% of FM deviation range + 2 \times Resolution), characteristic |
| Offset Error ^a | | 5% of FM Deviation Range + 300 Hz, characteristic |
| FM Bandwidth (-3 dB) | | |
| FM Deviation Range | | |
| 10 kHz to 40 kHz | | 7.5 \times FM deviation range, characteristic |
| >40 kHz to 200 kHz | | 1.3 \times FM deviation range, characteristic |
| >200 kHz to 1 MHz | | 0.3 \times FM deviation range, characteristic |

a. In time domain sweeps (span = 0 Hz).

TV Trigger and Picture On Screen (Option B7B)*Option BAA is required.*

| | Specifications | Supplemental Information |
|---|---|--|
| TV Trigger and Picture On Screen | | TV Trigger initiates a sweep of the analyzer after the sync pulse of a selected line of a TV video field. Picture On Screen displays the TV picture on the analyzer display. |
| Amplitude Requirements TV Source: SA | | Top 50% of linear display, characteristic |
| TV Source: EXT VIDEO IN | | 500 mV _{p-p} to 2 V _{p-p} , characteristic |
| Compatible Standards | NTSC-M, NTSC-Japan, PAL-M, PAL-B,D,G,H,I, PAL-N, PAL-N Combination, SECAM-L | |
| Field Selection | Entire frame, even, odd | |
| Sync Polarity | Positive or negative | |
| TV Trigger | | |
| Line Selection | 1 to 525, or 1 to 625, standard dependent | |

cdmaOne Measurement Personality (Option BAC)

Unless otherwise noted, all specifications are with RF input range auto, default cdmaOne measurement settings, and in the in-band frequency range. *Option B72* is required.

| | Specifications | Supplemental Information |
|--------------------------------|--|--------------------------|
| In-Band Frequency Range | | |
| Cellular bands | 824 to 870 MHz 869 to 925 MHz | |
| PCS bands | 1715 to 1780 MHz 1805 to 1870 MHz 1850 to 1910 MHz 1930 to 1990 MHz | |

| | Specifications | Supplemental Information |
|---|----------------------------|---|
| Adjacent Channel Power Ratio^a | | |
| Carrier power range at RF Input | 30 to -20 dBm | |
| Dynamic range ^b | | Referenced to average power of carrier in 1.23 MHz BW |
| Offset Frequency | Integration BW | |
| 750 kHz | 30 kHz | -70.0 dBc, characteristic |
| 885 kHz | 30 kHz | -73.5 dBc, characteristic |
| 1.25625 MHz | 12.5 kHz | -78.0 dBc, characteristic |
| 1.98 MHz | 30 kHz | -75.5 dBc, characteristic |
| 2.75 MHz | 1 MHz | -60.5 dBc, characteristic |
| Relative accuracy ^c | See Display Scale Fidelity | |
| Resolution | 0.01 dB | |

- a. This measurement is available with personality revisions of A.02.00 or later.
- b. IS-97A nominal base station test model levels (fraction of carrier power); Pilot: 0.20 (-7.0 dBc), Sync: 0.0471 (-13.3 dBc), Paging: 0.1882 (-7.3 dBc), 6 Traffic channels: 0.09412 (-10.3 dBc)
- c. Does not include uncertainty due to noise.

| | Specifications | Supplemental Information |
|--|----------------|--------------------------------------|
| Channel Power (1.23 MHz Integration BW) | | Integration BW range 1 kHz to 10 MHz |
| Range at RF Input | 30 to -70 dBm | |
| Absolute power accuracy for in-band signal (Mean channel power at RF Input, plus any external attenuation, excluding mismatch error) | | |
| Cellular Bands | | |
| 30 to -5 dBm 20 to 30 °C | ±0.82 dB | ±0.39 dB, typical |
| 0 to 55 °C | ±1.09 dB | |
| -5 to -25 dBm 20 to 30 °C | ±0.78 dB | ±0.37 dB, typical |
| 0 to 55 °C | ±1.05 dB | |
| -25 to -45 dBm 20 to 30 °C | ±0.69 dB | ±0.21 dB, typical |
| 0 to 55 °C | ±0.94 dB | |
| -45 to -55 dBm 20 to 30 °C | ±0.77 dB | ±0.28 dB, typical |
| 0 to 55 °C | ±0.96 dB | |
| -55 to -70 dBm 20 to 30 °C | ±0.89 dB | ±0.38 dB, typical |
| 0 to 55 °C | ±1.21 dB | |
| PCS Bands | | |
| 30 to -5 dBm 20 to 30 °C | ±0.78 dB | ±0.26 dB, typical |
| 0 to 55 °C | ±1.11 dB | |
| -5 to -25 dBm 20 to 30 °C | ±0.74 dB | ±0.23 dB, typical |
| 0 to 55 °C | ±1.02 dB | |
| -25 to -45 dBm 20 to 30 °C | ±0.71 dB | ±0.26 dB, typical |
| 0 to 55 °C | ±0.99 dB | |

Agilent E4405B Specifications and Characteristics
Options

| | Specifications | Supplemental Information |
|-------------------------------|----------------|--------------------------|
| -45 to -55 dBm 20 to 30 °C | ±0.79 dB | ±0.33 dB, typical |
| 0 to 55 °C | ±1.01 dB | |
| -55 to -70 dBm 20 to 30 °C | ±0.91 dB | ±0.43 dB, typical |
| 0 to 55 °C | ±1.26 dB | |

| | Specifications | Supplemental Information |
|---|----------------------------|--------------------------|
| Channel power relative power accuracy (same channel, different Tx power, input attenuator fixed, RF input range manual). | See Display Scale Fidelity | |

| | Specifications | Supplemental Information |
|------------------------------|----------------|--------------------------|
| Receive Channel Power | | |
| Absolute Power Accuracy | | |
| Cellular bands | | |
| 30 to 0 dBm | ±0.95 dB | ±0.53 dB, typical |
| 0 to -85 dBm | ±1.46 dB | ±0.63 dB, typical |
| PCS bands | | |
| 30 to 0 dBm | ±0.97 dB | ±0.52 dB, typical |
| 0 to -85 dBm | ±1.35 dB | ±0.59 dB, typical |
| Preamp (<i>Option 1DS</i>) | | |
| Cellular and PCS bands | | |
| 30 to -80 dBm | ±1.88 dB | ±1.15 dB, typical |
| -80 to -100 dBm | ±2.95 dB | ±1.93 dB, typical |

| | Specifications | Supplemental Information |
|--|----------------|--------------------------|
| Occupied Bandwidth | | |
| Carrier power range | 30 to -45 dBm | |
| Frequency resolution of occupied BW | 1.88 kHz | |
| Frequency accuracy of occupied BW (1.23 MHz channel BW) | | ±15 kHz, characteristic |
| Frequency resolution of delta frequency | 3.75 kHz | |

| | Specifications | Supplemental Information |
|---------------------------------------|----------------|--|
| Frequency accuracy of delta frequency | | $\pm (35 \text{ kHz} + \text{frequency reference error} \times \text{carrier frequency})$, characteristic |

| | Specifications | Supplemental Information |
|---|--------------------|--|
| Code Domain Power (Requires <i>Options 1D5, B7D, and B7E</i> . Measurement interval ≥ 1.25 ms unless otherwise noted.) | | |
| Carrier power range at RF Input (Pilot channel power > -11 dBc) | 30 to -13 dBm | 30 to -65 dBm ^a , characteristic |
| Preamp (<i>Option 1D5</i>) | 30 to -30 dBm | 30 to -82 dBm ^a , characteristic |
| Measurement interval range | 0.5 ms to 26.67 ms | |
| Code domain power | | |
| Display dynamic range | 50 dB | |
| Accuracy (Walsh channel power within 20 dB of total power) | | ± 0.2 dB, typical |
| Displayed resolution | 0.01 dB | |
| Other reported power parameters (dB referenced to total power) | | Average active traffic, maximum inactive traffic, average inactive traffic, pilot, paging, sync channels |
| Carrier frequency error (Measurement interval ≥ 2.5 ms) | | Excludes frequency reference error. |
| Input frequency error range | ± 100 kHz | ± 200 kHz, typical |
| Accuracy | ± 10 Hz | ± 7 Hz, typical |
| Displayed resolution | Four digits | |
| Estimated Rho | | |
| Range | 0.9 to 1.0 | 0.5 to 1.0 ^b |
| Accuracy (With 9 channels active over the specified range) ^c | | ± 0.02 , characteristic |
| Displayed resolution | 0.0001 | |

Agilent E4405B Specifications and Characteristics
Options

| | Specifications | Supplemental Information |
|---|------------------------|---|
| Pilot time offset | | From even second signal to start of PN sequence |
| Range | -13.33 ms to +13.33 ms | |
| Accuracy | ±150 ns | |
| Displayed resolution | Four digits | |
| Code domain timing | | Pilot to code channel time tolerance |
| Range | ±200 ns | |
| Accuracy (IS-97A nominal power levels) ^d | | ±7 ns, typical |
| Code domain phase | | Pilot to code channel phase tolerance |
| Range | ±200 mrad | |
| Accuracy (IS-97A nominal power levels) ^d | | ±10 mrad, typical |
| Displays | | Power Graph and Metrics, or Power, Timing, and Phase Graphs |

- a. Performance may degrade outside of the specified carrier power range at RF input listed in the specifications column.
- b. Performance may degrade outside of the estimated rho range listed in the specifications column.
- c. The Active Set Threshold is less than all active channels, but greater than -20 dBc.
- d. IS-97A nominal base station test model levels (fraction of carrier power); Pilot: 0.20 (-7.0 dBc), Sync: 0.0471 (-13.3 dBc), Paging: 0.1882 (-7.3 dBc), 6 Traffic channels: 0.09412 (-10.3 dBc)

| | Specifications | Supplemental Information |
|--|---------------------|---|
| Modulation Accuracy (Rho) (Requires <i>Options 1D5, B7D,</i> and <i>B7E</i> . Measurement interval ≥1.25 ms unless otherwise noted.) | | |
| Carrier power range at RF Input | 30 to -28 dBm | 30 to -70 dBm ^a , characteristic |
| Preamp (<i>Option 1DS</i>) | 30 to -45 dBm | 30 to -87 dBm ^a , characteristic |
| Measurement interval range | 0.15 ms to 26.67 ms | |
| Rho (waveform quality) | | |
| Range | 0.9 to 1.0 | 0.5 to 1.0 ^b , characteristic |
| Accuracy | | ±0.0016, typical |
| Displayed resolution | 0.0001 | |

| | Specifications | Supplemental Information |
|---|------------------------|--|
| Carrier frequency error (Measurement interval ≥ 2.5 ms) | | Excludes frequency reference error |
| Input frequency error range | ± 100 kHz | ± 200 kHz, typical |
| Accuracy | ± 10 Hz | ± 7 Hz, typical |
| Displayed resolution | Four digits | |
| Pilot time offset | | From even second signal to start of PN sequence |
| Range | -13.33 ms to +13.33 ms | |
| Accuracy | ± 150 ns | |
| Displayed resolution | Four digits | |
| EVM | | |
| Floor | | 3.8%, typical |
| Accuracy ^c | | $\pm 1.1\%$, typical |
| Displayed Resolution | 0.01% | |
| Carrier feedthrough | | |
| Floor | | -51 dBc, typical |
| Accuracy (Carrier feedthrough ≥ -43 dBc) | | ± 2.3 dB, typical |
| Displayed resolution | 0.01 dB | |
| Magnitude error | | |
| Floor | | 3.8%, typical |
| Accuracy ^c | | $\pm 1.1\%$, typical |
| Displayed resolution | 0.01% | |
| Phase error | | |
| Accuracy ^c | | ± 0.65 degrees, typical |
| Displayed resolution | 0.01 degrees | |
| Displays | | Numeric results or Numeric results and IQ graph |

- a. Performance may degrade outside of the specified carrier power range at RF input listed in the specifications column.
- b. Performance may degrade outside of the rho range listed in the specifications column.
- c. Accuracy does not include the effects of the EVM floor. The measurement variance increases as the result approaches the EVM floor.

| | Specifications | Supplemental Information |
|---------------------------------|--|--|
| Spur Close (In Band) | | |
| Carrier power range at RF Input | 30 to -12 dBm | |
| Dynamic range | | |
| Input power | | |
| 30 to 25 dBm | 55 dB | |
| 25 to 20 dBm | 50 dB | |
| 20 to -12 dBm | 46 dB | |
| Relative accuracy | $\pm(2.7 \text{ dB} + 0.01 \times (\text{dB from reference level}))$ | $\pm(0.3 \text{ dB} + 0.01 \times (\text{dB from reference level}))$, typical |
| Displayed resolution | 0.01 dB | |

| | Specifications | Supplemental Information |
|---|----------------|--|
| Out-of-Band Spurious^a | | Refer to the Amplitude specifications section in this guide. |

- a. The out-of-band measurement is made with the user-defined tables with 20 frequency ranges each (up to the top 10 spurs per range, 100 spurs maximum). Table parameters include frequency range, RBW, video BW, detector type, and amplitude test limits.

| | Specifications | Supplemental Information |
|---|----------------------|--------------------------------|
| Receiver Spurious Emissions | | |
| Spurious emission power range | -20 to -83 dBm | |
| Preamp On (<i>Option 1DS</i>) | -40 to -101 dBm | |
| Absolute spurious emission power accuracy | | |
| -20 to -60 dBm | $\pm 2.0 \text{ dB}$ | $\pm 1.1 \text{ dB}$, typical |
| -60 to -83 dBm | $\pm 3.8 \text{ dB}$ | $\pm 2.7 \text{ dB}$, typical |
| Preamp On (<i>Option 1DS</i>) | | |
| -40 to -70 dBm | $\pm 2.5 \text{ dB}$ | $\pm 1.3 \text{ dB}$, typical |
| -70 to -101 dBm | $\pm 4.0 \text{ dB}$ | $\pm 2.6 \text{ dB}$, typical |

| | Specifications | Supplemental Information |
|--|----------------|--------------------------|
| External Correction | | |
| External attenuation, external gain | | |
| Range | -90 to 90 dB | |
| Resolution | 0.01 dB | |

| | Specifications | Supplemental Information |
|--|---------------------|--|
| Trigger | | |
| Trigger source (Actual available choices dependent on measurement) | Free run, external | |
| <i>(Option B7D and B7E)</i> | Add RF Burst, frame | |
| Delay trigger | | |
| Range | 0 to 500 ms | |
| Resolution | 300 ns | |
| RF burst trigger level (Option B7E) | 0 to -25 dBc | |
| Trigger slope (External and RF burst) | Positive/Negative | |
| Frame timing period | 50 ns to 13.6533 s | |
| Frame synchronizing source | External frame sync | Rear panel connector labelled EXT FRAME SYNC (Option B7D) |
| Frame synchronizing slope | Positive/Negative | |

| | Specifications | Supplemental Information |
|--|-----------------------|---|
| Demod Trigger Source | | |
| Even second input (Frame trigger only, Option B7D and B7E) | | Rear panel connector labelled EXT FRAME SYNC |
| PN offset range | 0 to 511 x 64 [chips] | |

GSM Measurement Personality (Option BAH)

Unless otherwise noted, all specifications are with RF input range auto, default GSM measurement settings, and in the in-band frequency range. *Option 1D6* and *Option B72* are required.

| | Specifications | Supplemental Information |
|--------------------------------|--------------------------------------|--------------------------|
| In-Band Frequency Range | | |
| GSM 900, P-GSM bands | 890 to 915 MHz 935 to 960 MHz | |
| GSM 900, E-GSM bands | 880 to 915 MHz 925 to 960 MHz | |
| GSM 900, R-GSM bands | 876 to 915 MHz 921 to 960 MHz | |
| DCS 1800 bands | 1710 to 1785 MHz 1805 to 1880 MHz | |
| PCS 1900 bands | 1850 to 1910 MHz 1930 to 1990 MHz | |

| | Specifications | Supplemental Information |
|--|----------------|--------------------------|
| Transmitter Power (Requires <i>Option B7D</i> or <i>AYX</i>) | | |
| Range at RF Input | 30 to -60 dBm | |
| Absolute power accuracy for in-band signal (Mean channel power at RF Input, plus any external attenuation, excluding mismatch error) | | |
| P-GSM, E-GSM, and R-GSM Bands | | |
| 30 to -20 dBm 20 to 30 °C | ±0.81 dB | ±0.34 dB, typical |
| 0 to 55 °C | ±1.25 dB | |
| -20 to -30 dBm 20 to 30 °C | ±0.74 dB | ±0.31 dB, typical |
| 0 to 55 °C | ±1.06 dB | |

| | Specifications | Supplemental Information |
|-------------------------------|----------------|--------------------------|
| -30 to -40 dBm 20 to 30 °C | ± 0.79 dB | ± 0.31 dB, typical |
| 0 to 55 °C | ± 1.05 dB | |
| -40 to -50 dBm 20 to 30 °C | ± 0.95 dB | ± 0.47 dB, typical |
| 0 to 55 °C | ± 1.15 dB | |
| -50 to -60 dBm 20 to 30 °C | ± 1.09 dB | ± 0.60 dB, typical |
| 0 to 55 °C | ± 1.27 dB | |
| DCS 1800 and PCS 1900 Bands | | |
| 30 to -20 dBm 20 to 30 °C | ± 0.77 dB | ± 0.29 dB, typical |
| 0 to 55 °C | ± 1.27 dB | |
| -20 to -30 dBm 20 to 30 °C | ± 0.70 dB | ± 0.28 dB, typical |
| 0 to 55 °C | ± 1.05 dB | |
| -30 to -40 dBm 20 to 30 °C | ± 0.75 dB | ± 0.28 dB, typical |
| 0 to 55 °C | ± 1.04 dB | |
| -40 to -50 dBm 20 to 30 °C | ± 0.91 dB | ± 0.44 dB, typical |
| 0 to 55 °C | ± 1.14 dB | |
| -50 to -60 dBm 20 to 30 °C | ± 1.05 dB | ± 0.57 dB, typical |
| 0 to 55 °C | ± 1.26 dB | |

| | Specifications | Supplemental Information |
|---|----------------------------|--------------------------|
| Transmitter Power Relative Power Accuracy (same channel, different Tx power, input attenuator fixed, RF input range manual). | See Display Scale Fidelity | |

Agilent E4405B Specifications and Characteristics
Options

| | Specifications | Supplemental Information |
|---|----------------|---|
| Power versus Time (Requires <i>Option B7D</i> or <i>AYX</i>) | | |
| Carrier power range at RF Input | 30 to -23 dBm | 30 to -55 dBm ^a , characteristic |
| Preamp On (<i>Option 1DS</i>) | 30 to -40 dBm | 30 to -72 dBm ^a , characteristic |
| Time resolution accuracy | | ±1% of sweep time, characteristic |
| Maximum record length | 8 time slots | |
| Burst to mask uncertainty (Requires <i>Option B7D</i> and <i>B7E</i>) | ±1.0 bit | |

a. Performance may degrade outside of the specified carrier power range at RF input listed in the specifications column.

| | Specifications | Supplemental Information |
|--|--|------------------------------|
| Output RF Spectrum | | |
| Carrier power range at RF Input | | |
| Offsets ≤1800 kHz, 30 kHz RBW | | 30 to -5 dBm, characteristic |
| Offsets >1800 kHz, 100 kHz RBW | | 30 to -4 dBm, characteristic |
| Reference power accuracy | Same as Transmitter Power measurement | |
| Relative accuracy ^a | See Display Scale Fidelity | |
| Spectrum due to modulation displayed dynamic range ^{b,c} | | |
| 100 kHz offset | | 30 dB, characteristic |
| 200 kHz offset | | 60 dB, characteristic |
| 250 kHz offset | | 60 dB, characteristic |
| 400 kHz offset | | 70 dB, characteristic |
| 600 kHz to 1.8 MHz offset | | 79 dB, characteristic |
| 1.8 to 6.0 MHz offset | | 75 dB, characteristic |
| > 6 MHz offset | | 76 dB, characteristic |
| Swept Mode Dynamic Range | | 70 dB, characteristic |

| | Specifications | Supplemental Information |
|---|----------------|--------------------------|
| Spectrum due to switching transients displayed dynamic range ^{b,c} | | |
| 400 kHz offset | | 62 dB, characteristic |
| 600 kHz offset | | 79 dB, characteristic |
| 1200 kHz offset | | 79 dB, characteristic |
| 1800 kHz offset | | 80 dB, characteristic |
| Swept Mode Dynamic Range | | 70 dB, characteristic |

- Does not include uncertainty due to noise.
- Displayed dynamic range for specific frequency offsets—applies to CW signal at the specified offset. Dynamic range with a GSM signal may differ.
- Using default settings, the RBW filter has a corrected noise BW and impulse BW equivalent to five-pole synchronously tuned filter.

| | Specifications | Supplemental Information |
|---|----------------|---|
| Phase and Frequency Error (Requires <i>Option 1D5, B7D, and B7E</i>) | | |
| Carrier power range at RF Input | 30 to -23 dBm | 30 to -55 dBm ^a , characteristic |
| Preamp On (<i>Option 1D5</i>) | 30 to -40 dBm | 30 to -72 dBm ^a , characteristic |
| Phase error | | |
| Range | 0 to 180° | |
| Displayed resolution | 0.01° | |
| Accuracy (Averages ≥10) | | |
| Peak | ±2.1° | ±1.5°, typical |
| RMS | ±1.1° | ±0.6°, typical |
| Frequency error | | Excludes frequency reference error |
| Initial frequency error range | ±100 kHz | |
| Accuracy (Averages ≥10) | ±10 Hz | ±5 Hz, typical |
| I/Q offset range | -10 to -46 dBc | |
| Burst sync time uncertainty | ±0.1 bit | |
| Displays | | Numeric summary |

- Performance may degrade outside of the specified carrier power range at RF input listed in the specifications column.

Agilent E4405B Specifications and Characteristics
Options

| | Specifications | Supplemental Information |
|-----------------------------------|----------------|---|
| Transmit Band Spurious | | |
| Carrier power range at RF Input | | 30 to -12 dBm, typical |
| Dynamic range | | |
| Upper and lower adjacent segments | | 55 dB, characteristic |
| Upper and lower segments | | 44 dB, characteristic |
| Relative accuracy | | $\pm(0.3 \text{ dB} + 0.01 \times (\text{dB from reference level}))$, characteristic |
| Displayed resolution | 0.01 dB | |

| | Specifications | Supplemental Information |
|---|----------------|--|
| Out-of-Band Spurious^a | | |
| Absolute Spurious Power Accuracy | | Refer to the Amplitude specifications section in this guide. |
| Sensitivity ^b | | |
| RBW | | |
| 1 kHz | | -95 dBm, characteristic |
| 3 kHz | | -90 dBm, characteristic |
| 10 kHz | | -85 dBm, characteristic |
| 30 kHz | | -78 dBm, characteristic |
| 100 kHz | | -71 dBm, characteristic |
| 300 kHz | | -64 dBm, characteristic |
| 1 MHz | | -57 dBm, characteristic |
| 3 MHz | | -50 dBm, characteristic |

- a. The out-of-band spurious measurement is made in accordance with the tables defined in the appropriate GSM specification document. The measurement is made over several frequency ranges (up to 10 spurs per range, 100 spurs maximum).
- b. With input attenuation of 5 dB. For all other attenuation settings, add (input attenuation - 5) dB.

| | Specifications | Supplemental Information |
|--|----------------|--------------------------------|
| Receive Band Spurious | | |
| Spurious emission power range ^a | | -20 to -73 dBm, characteristic |
| Preamp On (<i>Option IDS</i>) | | -40 to -91 dBm, characteristic |
| Absolute spurious emission power accuracy | | ±1.4 dB, characteristic |
| -20 to -60 dBm | | ±2.0 dB, characteristic |
| -60 to -73 dBm | | |
| Preamp on (<i>Option IDS</i>) | | ±1.8 dB, characteristic |
| -40 to -70 dBm | | ±3.0 dB, characteristic |
| -70 to -91 dBm | | |

a. Requires bandpass filter centered on receive band, peak detector mode, 0 dB attenuation, 100 kHz RBW. Does not include insertion loss of bandpass filter.

| | Specifications | Supplemental Information |
|--------------------------------|----------------|---|
| Amplitude Range Control | | RF Input Autorange, Manually set Max Total Pwr Manually set Input Atten |

| | Specifications | Supplemental Information |
|--|----------------|--------------------------|
| External Gain/Attenuation Correction | | |
| Base gain, base attenuation, mobile gain, mobile attenuation | | |
| Range | 0 to 81.9 dB | |
| Resolution | 0.01 dB | |

| | Specifications | Supplemental Information |
|--|------------------------|--------------------------|
| Trigger | | |
| Trigger source (Actual available choices dependent on measurement) | Free run, external | |
| (<i>Option B7D and B7E</i>) | Add RF Burst and frame | |

Agilent E4405B Specifications and Characteristics
Options

| | Specifications | Supplemental Information |
|---------------------------------------|-------------------------------------|--------------------------|
| RF burst trigger (Option B7E) | | |
| Peak carrier power range ^a | 30 to -25 dBm | 30 to -30 dBm, typical |
| Preamp On (Option IDS) | 30 to -45 dBm | 30 to -50 dBm, typical |
| Trigger level range | 0 to -25 dB relative to signal peak | |

a. With trigger level set to -6 dB.

| | Specifications | Supplemental Information |
|--|-----------------------|---|
| Burst Sync (Requires Option AYX or B7D) | | |
| Source (Actual available choices dependent on measurement) | RF amplitude, none | |
| (Option B7D and B7E) | Add training sequence | |
| Training sequence code | | GSM defined 0 to 7 Auto (search) or Manual |
| Burst type | | Normal (TCH and CCH) Sync (SCH) Access (RACH) |

General

| | Specifications | Supplemental Information |
|--------------------------|----------------|--------------------------|
| Temperature Range | | |
| Operating | 0 to 55 °C | Floppy disk 10 to 40 °C |
| Storage | -40 to 75 °C | |

| | Specifications | Supplemental Information |
|-------------------------------------|----------------|----------------------------|
| Audible Noise (ISO 7779) | | |
| Sound Pressure at 25 °C | | <40 dBa, (<4.6 Bels power) |

| | Specifications | Supplemental Information |
|-------------------------------|---|--------------------------|
| Military Specification | Has been type tested to the environmental specifications of MIL-PRF-28800F class 3. | |

| | Specifications | Supplemental Information |
|---------------------------------|---|--------------------------|
| EMI Compatibility | Conducted and radiated emission is in compliance with CISPR Pub. 11/1990 Group 1 Class A. | |
| <i>(Option 060)^a</i> | Conducted and radiated emission is in compliance with CISPR Pub. 11/1990 Group 1 Class B ^b . | |

a. Option 060 is not compatible with Option B7B nor Option 1DP.

b. Meets Class A performance during dc operation.

| | Specifications | Supplemental Information |
|-------------------------|----------------|---|
| Immunity Testing | | |
| Radiated Immunity | | Testing was done at 3 V/m according to IEC 801-3/1984. When the analyzer tuned frequency is identical to the immunity test signal frequency, there may be signals of up to -60 dBm displayed on the screen. |

Agilent E4405B Specifications and Characteristics
General

| | Specifications | Supplemental Information |
|-------------------------|-----------------------|---|
| Electrostatic Discharge | | Air discharges of up to 8 kV were applied according to IEC 801-2/1991. Discharges to center pins of any of the connectors may cause damage to the associated circuitry. |

| | Specifications | Supplemental Information |
|----------------------------|--|---------------------------------|
| Power Requirements | | |
| ac Operation | | |
| Voltage, frequency | 90 to 132 Vrms, 47 to 440 Hz 195 to 250 Vrms, 47 to 66 Hz | |
| Power Consumption, On | <300 W | |
| Power Consumption, Standby | <5 W | |
| dc Operation | | |
| Voltage | 12 to 20 Vdc | |
| Power Consumption | <200 W | |
| Power Consumption, Standby | <100 mW | |

| | Specifications | Supplemental Information |
|--|-----------------------|---------------------------------|
| Measurement Speed | | |
| Local Measurement and Display Update rate ^a | | |
| Sweep points = 101 | | ≥ 40/s, characteristic |
| Sweep points = 401 | | ≥ 28/s, characteristic |
| Remote Measurement and GPIB Transfer Rate ^{b,c} | | |
| <i>(Option A4H)</i> | | |
| Sweep points = 101 | | ≥ 40/s, characteristic |
| Sweep points = 401 | | ≥ 28/s, characteristic |

| | Specifications | Supplemental Information |
|--|----------------|--|
| RF Center Frequency Tune, Measure, and GPIB Transfer Time ^{b,d} (Option A4H) Sweep points = 101 Sweep points = 401 | | ≤ 75 ms, characteristic ≤ 90 ms, characteristic |

- a. Factory preset, auto align Off, segmented sweep Off, fixed center frequency, RBW = 1 MHz, spans >10 MHz and ≤600 MHz, and stop frequency ≤3 GHz.
- b. Display Off (:DISPlay:ENABLE OFF), and 32-bit integer data format (:FORMat:DATA INT,32), if *Option AYX* or *A4J* is installed, disable sweep ramp, (:SYSem:PORTs:IFVSWEEP:ENABLE OFF), markers Off, single sweep, measured with IBM compatible PC with 550 MHz Pentium® III running Windows® NT 4.0, one meter GPIB cable, National Instruments PCI-GPIB card and NI-488.2 DLL.
- c. Factory preset, auto align Off, fixed center frequency, RBW = 1 MHz, and span = 20 MHz, fixed center frequency, stop frequency ≤3 GHz, average of 100 measurements.
- d. Factory preset, auto align Off, segmented sweep Off, RBW = 1 MHz, span= 20 MHz, stop frequency ≤3 GHz, center frequency tune step size = 50 MHz.

| | Specifications | Supplemental Information |
|--|----------------|--|
| Data Storage Internal External (10 to 40 °C) 3.5" 1.44 MB, MS-DOS® compatible floppy disk | | 200 Traces or States ^a 200 Traces or States ^a |

- a. When storing traces set to 401 points.

| | Specifications | Supplemental Information |
|--|----------------|---|
| Downloadable Program Memory (Option B72) | | 2 MB available memory 10 MB available memory |

| | Specifications | Supplemental Information |
|--|------------------|---|
| Demod Tune and Listen Demod (Option BAA or 106) | AM Add FM | Internal speaker, front-panel earphone jack and front-panel volume control. |

Agilent E4405B Specifications and Characteristics
General

| | Specifications | Supplemental Information |
|----------------------------|-----------------------|---|
| <i>(Option A4J or AYY)</i> | | An uncalibrated demodulated signal is available on the AUX VIDEO OUT connector at the rear panel. |
| <i>(Option 106 or BAA)</i> | | An uncalibrated demodulated signal is available on the EXT VIDEO OUT connector at the rear panel. |

| | Specifications | Supplemental Information |
|---------------------------------|-----------------------|-----------------------------------|
| Weight (without options) | | |
| Net | | 17.1 kg (37.7 lb), characteristic |
| Shipping | | 31.9 kg (70.3 lb), characteristic |

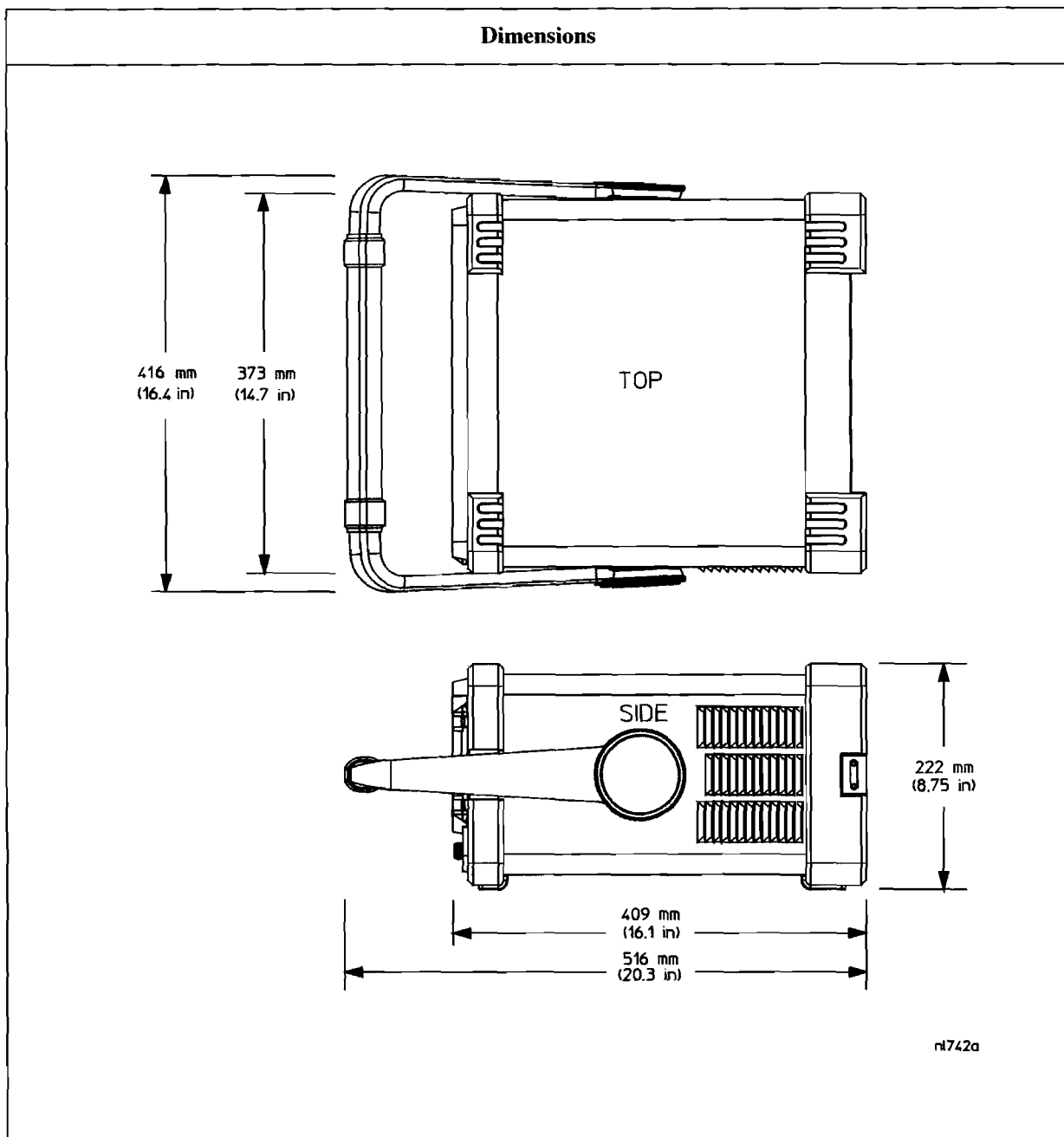

Inputs and Outputs

Front Panel

| | Specifications | Supplemental Information |
|-------------------|----------------|--------------------------|
| INPUT 50 Ω | | |
| Connector | Type-N female | |
| Impedance | | 50 Ω, nominal |

| | Specifications | Supplemental Information |
|----------------------------------|----------------|--------------------------|
| RF OUT 50 Ω, (Option 1DN) | | |
| Connector | Type-N female | |
| Impedance | | 50 Ω, nominal |

| | Specifications | Supplemental Information |
|----------------------------------|----------------|--|
| AMPTD REF OUT^a | | Amplitude Reference |
| Connector | BNC female | |
| Impedance | | 50 Ω, nominal |
| Frequency | | 50 MHz |
| Frequency Accuracy | | Frequency reference error ^b |
| 50 Ω Amplitude ^c | | -20 dBm, nominal |

- a. Turn the amplitude reference on/off by pressing the keys: **Input/Output, Amptd Ref Out.**
- b. Frequency reference error = (aging rate × period of time since adjustment + settability + temperature stability).
- c. The internal amplitude reference actual power is stored internally.

| | Specifications | Supplemental Information |
|--------------------|----------------|--|
| PROBE POWER | | |
| Voltage/Current | | +15 Vdc, ±7% at 150 mA max., characteristic -12.6 Vdc ±10% at 150 mA max., characteristic |

Inputs and Outputs

| | Specifications | Supplemental Information |
|---------------------------------|-----------------------|---|
| EXT KEYBOARD^a | | Used for entering screen titles and filenames only. Interface compatible with most IBM-compatible PC keyboards. |
| Connector | 6-pin mini-DIN | |

a. The feature is not implemented in firmware revisions prior to A.04.00.

| | Specifications | Supplemental Information |
|----------------|-----------------------|----------------------------------|
| Speaker | | Front panel knob controls volume |

| | Specifications | Supplemental Information |
|------------------|--|--|
| Headphone | | Front panel knob controls volume |
| Connector | 3.5 mm (1/8 inch) miniature audio jack | |
| Power Output | | 0.2 W into 4 Ω , characteristic |

Rear Panel

| | Specifications | Supplemental Information |
|-----------------------|-----------------------|---------------------------------|
| 10 MHz REF OUT | | |
| Connector | BNC female | |
| Impedance | | 50 Ω , nominal |
| Output Amplitude | | >0 dBm, characteristic |

| | Specifications | Supplemental Information |
|-----------------------|-----------------------|---|
| 10 MHz REF IN | | |
| Connector | BNC female | Note: Analyzer noise sidebands and spurious response performance may be affected by the quality of the external reference used. |
| Impedance | | 50 Ω , nominal |
| Input Amplitude Range | | -15 to +10 dBm, characteristic |
| Frequency | | 10 MHz, nominal |

Agilent E4405B Specifications and Characteristics
Inputs and Outputs

| | Specifications | Supplemental Information |
|--|--|---------------------------------|
| EXT REF IN <i>(Option B7E)</i> | | |
| Connector | BNC, female | |
| Impedance | | 50 Ω, nominal |
| Input amplitude range | -5 to 10 dBm | |
| Frequency | 1 to 30 MHz, selectable | |
| Frequency lock range | $\pm 5 \times 10^{-6}$ of specified external reference input frequency | |

| | Specifications | Supplemental Information |
|--|-----------------------|------------------------------------|
| 10 MHz OUT <i>(Option B7E)</i> | | |
| Connector | BNC, female | |
| Impedance | | 50 Ω, nominal |
| Frequency | | 10 MHz, nominal |
| Level | | 0 dBm when Option 10 MHz Out is On |

| | Specifications | Supplemental Information |
|--|-----------------------|---|
| GATE TRIG/EXT TRIG IN | | |
| Connector | BNC female | |
| External Trigger Input | | |
| Trigger Level | | Selectable positive or negative edge initiates sweep in EXT TRIG mode (5 V TTL) |
| Gate Trigger Input <i>(Option 1D6)</i> | | |
| Minimum Pulse Width | | >30 ns (5 V TTL) |

| | Specifications | Supplemental Information |
|---|----------------|---|
| GATE/HI SWP OUT | | |
| Connector | BNC female | |
| High Sweep Output Level | | High = sweep ^a ; Low = retrace (5 V TTL) |
| Gate Output (<i>Option 1D6</i>) Level | | High = gate on; Low = gate off (5 V TTL) |

a. High sweep may be high longer than the indicated sweep times.

| | Specifications | Supplemental Information |
|-------------------|-----------------------------------|--|
| VGA OUTPUT | | |
| Connector | VGA compatible, 15-pin mini D-SUB | |
| Format | | VGA (31.5 kHz horizontal, 60 Hz vertical sync rates, non-interlaced) Analog RGB |
| Resolution | 640 × 480 | |

| | Specifications | Supplemental Information |
|--|----------------|---------------------------------------|
| AUX IF OUT (<i>Option A4J or AYX</i>) | | RBW ≥ 1 kHz |
| Connector | BNC female | |
| Frequency | | 21.4 MHz, nominal |
| Amplitude (for signal at reference level and for reference levels – input attenuation + preamp gain of –10 to –70 dBm) | | –10 dBm (uncorrected), characteristic |
| Impedance | | 50 Ω, nominal |

Agilent E4405B Specifications and Characteristics
Inputs and Outputs

| | Specifications | Supplemental Information |
|--|----------------|--|
| AUX VIDEO OUT <i>(Option A4J or AYX)</i> | | RBW \geq 1 kHz |
| Connector | BNC female | |
| Amplitude Range (into >10 k Ω) | | 0 to 1 V (uncorrected), characteristic |

| | Specifications | Supplemental Information |
|--|----------------|--|
| HI SWP IN <i>(Option A4J or AYX)</i> | | |
| Connector | BNC female | |
| Input | | Open collector, low resets and holds the sweep (5 V TTL) |

| | Specifications | Supplemental Information |
|---|----------------|---|
| HI SWP OUT <i>(Option A4J or AYX)</i> | | |
| Connector | BNC female | |
| Output | | High = sweep ^a , Low = retrace (5 V TTL) |

a. High sweep may be high longer than the indicated sweep times.

| | Specifications | Supplemental Information |
|--|----------------|---------------------------------|
| SWP OUT <i>(Option A4J or AYX)</i> | | |
| Connector | BNC female | |
| Amplitude | | 0 to +10 V ramp, characteristic |

| | Specifications | Supplemental Information |
|-----------------------------|----------------|--|
| PRESEL TUNE OUTPUT | | |
| Connector | BNC female | |
| Load Impedance (dc coupled) | | > 10 k Ω , nominal |
| Range | | 0 to +10 V, characteristic |
| Sensitivity | | 0.33 V/GHz of tuned frequency > 3 GHz, characteristic |

| | Specifications | Supplemental Information |
|---|------------------------|--|
| GPIB Interface (<i>Option A4H</i>) | | |
| Connector | IEEE-488 bus connector | |
| GPIB Codes | | SH1, AH1, T6, SR1, RL1, PP0, DC1, C1, C2, C3 and C28 |

| | Specifications | Supplemental Information |
|---|------------------|--------------------------|
| Serial Interface (<i>Option IAX</i>) | | |
| Connector | 9-pin D-SUB male | RS-232 |

| | Specifications | Supplemental Information |
|---|---------------------|--------------------------|
| Parallel Interface (<i>Option A4H or IAX</i>) | | |
| Connector | 25-pin D-SUB female | Printer port only |

| | Specifications | Supplemental Information |
|--|---------------------------|--|
| EXT VIDEO IN/TV TRIG OUT^a (<i>Option B7B or BAA</i>) | | |
| Connector | BNC Female (75 Ω) | EXT VIDEO IN is the Baseband composite video input for TV trigger and picture on screen. TV TRIG OUT is the TV trigger output. |
| Impedance | | 75 Ω , nominal |
| (<i>Option BAA without Option B7B</i>) | | Feature not implemented |
| (<i>Option BAA with Option B7B</i>) | | |
| External Video Input Video Amplitude | | 1 V _{p-p} , nominal, characteristic |
| TV Trigger Output | | Positive edge indicates start of selected TV line after sync. pulse |
| Amplitude | | TTL (0 V and 3.4 V with 75 Ω series resistance), characteristic |

- a. This connector is labelled EXT VIDEO IN on older spectrum analyzers and EXT VIDEO IN/TV TRIG OUT on newer spectrum analyzers.

Agilent E4405B Specifications and Characteristics
Inputs and Outputs

| | Specifications | Supplemental Information |
|--|--|---|
| EXT VIDEO OUT <i>(Option B7B or BAA)</i> Connector Impedance <i>(Option BAA without Option B7B)</i> Amplitude <i>(Option BAA with Option B7B)</i> Amplitude TV Source: SA TV Source and EXT VIDEO IN <i>(Option 106)</i> Connector Impedance Amplitude | BNC female (75 Ω) BNC female (75 Ω) | Baseband video output RBW ≥ 1 kHz 75 Ω, nominal 0 to 1 V (uncorrected), characteristic 0 to 1 V (uncorrected), characteristic Same as level at EXT VIDEO IN/TV TRIG OUT, characteristic 75 Ω, nominal 0 to 1 V (uncorrected), characteristic |

| | Specifications | Supplemental Information |
|--|-----------------------|---------------------------------|
| EXT FRAME SYNC <i>(Option B7D)</i> Connector Level | BNC, female | 5 V TTL |

Regulatory Information

CAUTION

This product is designed for use in Installation Category II and Pollution Degree 2 per IEC 1010 and 664 respectively.

NOTE

This product has been designed and tested in accordance with IEC Publication 1010, Safety Requirements for Electronic Measuring Apparatus, and has been supplied in a safe condition. The instruction documentation contains information and warnings which must be followed by the user to ensure safe operation and to maintain the product in a safe condition.



The CE mark is a registered trademark of the European Community (if accompanied by a year, it is the year when the design was proven).



The CSA mark is the Canadian Standards Association safety mark.

ISM 1-A

This is a symbol of an Industrial Scientific and Medical Group 1 Class A product. (CISPR 11, Clause 4)

Declaration of Conformity

| DECLARATION OF CONFORMITY | |
|---|---|
| According to ISO/IEC Guide 22 and CEN/CENELEC EN 45014 | |
| Manufacturer's Name: | Agilent Technologies, Inc. |
| Manufacturer's Address: | 1400 Fountaingrove Parkway Santa Rosa, CA 95403-1799 USA |
| Declares that the products | |
| Product Name: | Spectrum Analyzer |
| Model Number: | E4401B, E4402B, E4403B, E4404B, E4405B, E4407B, E4408B, E4411B |
| Product Options: | This declaration covers all options of the above products. |
| Conform to the following product specifications: | |
| EMC: IEC 61326-1:1997+A1:1998 / EN 61326-1:1997+A1:1998 | |
| <u>Standard</u> | <u>Limit</u> |
| CISPR 11:1990 / EN 55011-1991 | Group 1, Class A |
| IEC 61000-4-2:1995+A1998 / EN 61000-4-2:1995 | 4 kV CD, 8 kV AD |
| IEC 61000-4-3:1995 / EN 61000-4-3:1995 | 3 V/m, 80 - 1000 MHz |
| IEC 61000-4-4:1995 / EN 61000-4-4:1995 | 0.5 kV sig., 1 kV power |
| IEC 61000-4-5:1995 / EN 61000-4-5:1996 | 0.5 kV L-L, 1 kV L-G |
| IEC 61000-4-6:1996 / EN 61000-4-6:1998 | 3 V, 0.15 - 80 MHz |
| IEC 61000-4-11:1994 / EN 61000-4-11:1998 | 1 cycle, 100% |
| Safety: IEC 61010-1:1990 + A1:1992 + A2:1995 / EN 61010-1:1993 +A2:1995 CAN/CSA-C22.2 No. 1010.1-92 | |
| Supplementary Information: The products herewith comply with the requirements of the Low Voltage Directive 73/23/EEC and the EMC Directive 89/336/EEC and carry the CE-marking accordingly. | |
|  | |
| Santa Rosa, CA, USA | 17 April 2000 |
| Greg Pfeiffer/Quality Engineering Manager | |
| For further information, please contact your local Agilent Technologies sales office, agent or distributor. | |

5

**Agilent E4407B Specifications and
Characteristics**

About This Chapter

This chapter contains specifications and characteristics for the Agilent E4407B spectrum analyzer. The distinction between specifications and characteristics is described as follows.

- Specifications describe the performance of parameters covered by the product warranty. (The temperature range is 0 °C to 55 °C, unless otherwise noted.)
- Characteristics describe product performance that is useful in the application of the product, but is not covered by the product warranty.
- Typical performance describes additional product performance information that is not covered by the product warranty. It is performance beyond specification that 80% of the units exhibit with a 95% confidence level over the temperature range 20 to 30 °C. Typical performance does not include measurement uncertainty.
- Nominal values indicate the expected performance, or describe product performance that is useful in the application of the product, but is not covered by the product warranty.

The following conditions must be met for the analyzer to meet its specifications.

- o The analyzer is within the one year calibration cycle.
- o If **Auto Align All** is selected:
 - After 2 hours of storage within the operating temperature range.
 - 5 minutes after the analyzer is turned on with sweep times less than 4 seconds.
 - After the front-panel amplitude reference is connected to the INPUT, and **Align Now RF** has been run, after the analyzer is turned on. And, once every 24 hours, or if ambient temperature changes more than 30 °C¹.

1. 10 °C if Preamp (*Option 1DS*) is active.

- o If **Auto Align Off** is selected:
 - When the analyzer is at a constant temperature, within the operating temperature range, for a minimum of 90 minutes.
 - After the analyzer is turned on for a minimum of 90 minutes, the front panel amplitude reference has been connected to the INPUT, and **Align Now All** has been run.
 - When **Align Now All** is run:
 - Every hour
 - If the ambient temperature changes more than 3 °C
 - If the 10 MHz reference changes
 - When **Align Now RF** is run (with the front-panel amplitude reference connected to the INPUT):
 - Every 24 hours
 - If the ambient temperature changes more than 30 °C¹
- o If **Auto Align All but RF** is selected:
 - When the analyzer is at a constant temperature, within the operating temperature range, for a minimum of 90 minutes.
 - After the analyzer is turned on for a minimum of 90 minutes, the front panel amplitude reference has been connected to the INPUT, and **Align Now RF** has been run.
 - When **Align Now RF** is run (with the front-panel amplitude reference connected to the INPUT):
 - Every hour
 - If the ambient temperature changes more than 3 °C

1. 10 °C if Preamp (*Option IDS*) is active.

Frequency

| | Specifications | Supplemental Information | |
|-------------------------------------|--------------------|--|---------------|
| Frequency Range | 9 kHz to 26.5 GHz | | |
| dc coupled | 100 Hz to 26.5 GHz | 30 Hz to 26.5 GHz, characteristic | |
| ac coupled | 10 MHz to 26.5 GHz | | |
| Band | | Harmonic Mixing Mode (N ^a) | |
| 0 (0 Hz to 3.0 GHz) | | 1- | |
| 1 (2.85 GHz to 6.7 GHz) | | 1- | |
| 2 (6.2 GHz to 13.2 GHz) | | 2- | |
| 3 (12.8 GHz to 19.2 GHz) | | 4- | |
| 4 (18.7 GHz to 26.5 GHz) | | 4- | |
| Preamp On (Option IDS) | 1 MHz to 3.0 GHz | | |
| (Option UKB) | | | |
| dc coupled | 1 MHz to 3.0 GHz | | |
| ac coupled | 10 MHz to 3.0 GHz | | |
| External Mixing (Option AYZ) | 18 GHz to 325 GHz | | |
| | | Harmonic Mixing Mode (N ^a) | |
| Band | | Preselected | Unpreselected |
| K (18.0 GHz to 26.5 GHz) | | n/a | 6- |
| A (26.5 GHz to 40.0 GHz) | | 8+ | 8- |
| Q (33.0 GHz to 50.0 GHz) | | 10+ | 10- |
| U (40.0 GHz to 60.0 GHz) | | 10+ | 10- |
| V (50.0 GHz to 75.0 GHz) | | 14+ | 14- |
| E (60.0 GHz to 90.0 GHz) | | n/a | 16- |
| W (75.0 GHz to 110.0 GHz) | | n/a | 18- |
| F (90.0 GHz to 140.0 GHz) | | n/a | 20- |
| D (110.0 GHz to 170.0 GHz) | | n/a | 24- |

| | Specifications | Supplemental Information | |
|----------------------------|----------------|--------------------------|-----|
| G (140.0 GHz to 220.0 GHz) | | n/a | 32– |
| Y (170.0 GHz to 260.0 GHz) | | n/a | 38– |
| J (220.0 GHz to 325.0 GHz) | | n/a | 46– |

- a. N is the harmonic mixing mode. For negative mixing modes (as indicated by the “–”), the desired 1st LO harmonic is higher than the tuned frequency by the 1st IF (3.9214 for the 9 kHz to 3 GHz band, 321.4 MHz for all other bands) For positive mixing modes, the desired 1st LO harmonic is lower than the tuned frequency by 321.4 MHz.

| | Specifications | Supplemental Information |
|----------------------------|------------------------------|---|
| Frequency Reference | | |
| Aging Rate | $\pm 2 \times 10^{-6}$ /year | $\pm 1.0 \times 10^{-7}$ /day, characteristic |
| Settability | $\pm 5 \times 10^{-7}$ | |
| Temperature Stability | $\pm 5 \times 10^{-6}$ | |

| | Specifications | Supplemental Information |
|--|------------------------------|---|
| High Stability Frequency Reference (Option 1D5) | | |
| Aging Rate | $\pm 1 \times 10^{-7}$ /year | $\pm 5 \times 10^{-10}$ /day, 7-day average after being powered on for 7 days, characteristic |
| Settability | $\pm 1 \times 10^{-8}$ | |
| Temperature Stability | | |
| 20 to 30 °C | $\pm 1 \times 10^{-8}$ | |
| 0 to 55 °C | $\pm 5 \times 10^{-8}$ | |
| Warm-up (Internal frequency reference selected) | | |
| After 5 minutes | | $< \pm 1 \times 10^{-7}$ of final frequency, ^a characteristic |
| After 15 minutes | | $< \pm 1 \times 10^{-8}$ of final frequency, ^a characteristic |

- a. Final frequency is defined as frequency 60 minutes after power-on with analyzer set to internal frequency reference.

Agilent E4407B Specifications and Characteristics
Frequency

| | Specifications | Supplemental Information |
|--|---|--------------------------|
| Frequency Readout Accuracy (Start, Stop, Center, Marker) | $\pm((\text{frequency indication} \times \text{frequency reference error}^{\text{a}}) + 0.5\% \text{ of span} + \frac{\text{span}}{\text{sweep points} - 1} + 15\% \text{ of RBW} + 10 \text{ Hz} + 1 \text{ Hz} \times \text{N}^{\text{b}})$ | |

- a. Frequency reference error = (aging rate \times period of time since adjustment + settability + temperature stability).
b. N is the harmonic mixing mode.

| | Specifications | Supplemental Information |
|---------------------------------|--|--------------------------|
| Marker Frequency Counter | | |
| Resolution | Selectable from 1 Hz to 100 kHz | |
| Accuracy ^a | $\pm(\text{marker frequency} \times \text{frequency reference error}^{\text{b}} + \text{counter resolution})^{\text{c}}$ | For RBW \geq 1 kHz |

- a. Marker level to displayed noise level > 25 dB, RBW/ Span \geq 0.002, frequency offset = 0 Hz.
b. Frequency reference error = (aging rate \times period of time since adjustment + settability + temperature stability).
c. For firmware revisions prior to A.03.00, add 1 Hz \times N, where N is the harmonic mixing mode.

| | Specifications | Supplemental Information |
|---------------------------------|---|--------------------------|
| Frequency Span | | |
| Range | | |
| Internal Mixing | 0 Hz (zero span), 100 Hz to 26.5 GHz | |
| External Mixing (Option AYZ) | 0 Hz (zero span), Minimum span = 100 Hz | |
| Resolution | $2 \text{ Hz} \times \text{N}^{\text{a}}$ | |
| Accuracy ^b | $\pm(0.5\% \text{ of span} + 2 \times \frac{\text{span}}{\text{sweep points} - 1})$ | |

- a. N is the harmonic mixing mode.
b. Applies to each sweep segment.

| | Specifications | Supplemental Information |
|--|--|---|
| Sweep Time | | |
| Range | | |
| Span > 0 Hz | 1 ms to 4000 s ^a | $\frac{\text{sweep points} - 1}{100 \text{ kHz}}$ to 4000 s |
| Span = 0 Hz | 10 μ s to 4000 s ^{a,b} | |
| Tracking Generator On (Option 1DN) | | 50 ms is the minimum sweep time |
| Fast Time-domain Sweep (Option AYX) (For Span = 0 Hz, RBW \geq 1 kHz) | 50 ns to 4000 s ^{c,d} | $\frac{\text{sweep points} - 1}{20 \text{ MHz}}$ to 4000 s |
| DSP and fast ADC (Option B7D) (For Span = 0 Hz, RBW \geq 1 kHz) | 25 ns to 4000 s ^e | $\frac{\text{sweep points} - 1}{40 \text{ MHz}}$ to 4000 s |
| Accuracy (Span = 0 Hz) | | |
| 10 μ s to 4000 s ^{a,b} | $\pm 1\%$ | |
| (Option AYX) 50 ns to 4000 s ^{c,d} | $\pm 1\%$ | |
| (Option B7D) 25 ns to 4000 s ^e | $\pm 1\%$ | |
| Sweep Trigger ^{f,g} | Free Run, Single, Line, Video ^h , External, Delayed, Offset ⁱ | |
| (Option 1D6) | Add Gate | |
| (Option B7B) | Add TV | |
| (Option B7E) | Add Burst Carrier Trigger | |
| Delayed Trigger ^{g,j} | | |
| Range | 1 μ s to 400 s | |
| Resolution | $\frac{\text{delay in seconds}}{65000}$ rounded up to nearest μ s | |
| Accuracy | $\pm(500 \text{ ns} + (0.01\% \text{ of delay}))$ | |

Agilent E4407B Specifications and Characteristics
Frequency

| | Specifications | Supplemental Information |
|--|---|---|
| Offset Trigger | | |
| Resolution | $\frac{\text{sweep time}}{\text{sweep points} - 1}$ | |
| Range | $\pm 327 \text{ ms to } \pm 12.3 \text{ ks}$ | Where ST = sweep time and SP = sweep points $\frac{-32766 \times \text{ST}}{\text{SP} - 1}$ to $\frac{(32766 - \text{SP}) \times \text{ST}}{\text{SP} - 1}$ |
| Fast Time-domain sweep (Option AYX) (For sweep times $\frac{\text{sweep points} - 1}{20 \text{ MHz}}$ to $\frac{\text{sweep points} - 1}{100 \text{ kHz}}$) | $\pm 1.23 \text{ ms to } \pm 245 \text{ ms}$ | $\frac{-32766 \times \text{ST}}{\text{SP} - 1}$ to $\frac{(32766 - \text{SP}) \times \text{ST}}{\text{SP} - 1}$ |
| DSP and fast ADC (Option B7D) (For sweep times $\frac{\text{sweep points} - 1}{40 \text{ MHz}}$ to $\frac{\text{sweep points} - 1}{100 \text{ kHz}}$) | $\pm 13 \text{ ms to } \pm 5.15 \text{ s}$ | $\frac{-524031 \times \text{ST}}{\text{SP} - 1}$ to $\frac{(524031 - \text{SP}) \times \text{ST}}{\text{SP} - 1}$ |

- a. For firmware revisions prior to A.04.00, 5 ms to 2000 s.
- b. For firmware revisions prior to A.05.00, 1 ms to 4000 s.
- c. For firmware revisions prior to A.04.00, 20 μs to 2000 s.
- d. For firmware revisions prior to A.05.00, 5 μs to 4000 s.
- e. For firmware revisions prior to A.05.00, 2.5 μs to 4000 s.
- f. Gate cannot be used simultaneously with delayed or TV trigger (Option B7B).
- g. Auto align is suspended in video, external, gate, and delayed trigger modes while waiting for a trigger event to occur.
- h. Unavailable when $\text{RBW} \leq 300 \text{ Hz}$ (Option 1DR).
- i. For firmware revision A.04.00 or later.
- j. Delayed trigger is available with line, external trigger, and TV trigger (Option B7B).

| | Specifications | Supplemental Information |
|-----------------------------|--------------------------|--------------------------|
| Sweep (trace) Points | | |
| Range | | |
| Span > 0 Hz | 101 to 8192 ^a | |
| Span = 0 Hz | 2 to 8192 ^{a,b} | |

- a. For firmware revisions prior to A.04.00, 401 points.
- b. For firmware revisions prior to A.05.00, 101 to 8192 points.

Agilent E4407B Specifications and Characteristics
Frequency

| | Specifications | Supplemental Information |
|-------|----------------|--|
| Shape | | Post detection, single pole low-pass filter used to average displayed noise Video bandwidths below 30 Hz are digital bandwidths with anti-aliasing filtering. |

| | Specifications | Supplemental Information |
|--|--|---|
| Stability | | |
| Noise Sidebands (Offset from CW signal with 1 kHz RBW, 30 Hz VBW and sample detector) | | |
| ≥1 kHz (<i>Option 1DR, 1D5</i>) | | ≤ -78 dBc/Hz ^a , typical |
| ≥10 kHz | ≤ -90 dBc/Hz ^a | ≤ -94 dBc/Hz ^a , typical |
| ≥20 kHz | ≤ -100 dBc/Hz ^a | ≤ -105 dBc/Hz ^a , typical |
| ≥30 kHz | ≤ -106 dBc/Hz ^a | ≤ -112 dBc/Hz ^a , typical |
| ≥100 kHz | ≤ -119 dBc/Hz ^a | ≤ -122 dBc/Hz ^a , typical |
| ≥1 MHz | ≤ -125 dBc/Hz ^a | ≤ -127 dBc/Hz ^a , typical |
| ≥5 MHz | ≤ -127 dBc/Hz ^a | ≤ -129 dBc/Hz ^a , typical |
| ≥10 MHz | ≤ -131 dBc/Hz ^a | ≤ -136 dBc/Hz ^a , typical |
| (<i>Option 120</i>) | | |
| ≥1 MHz | ≤ -133 dBc/Hz ^a | ≤ -136 dBc/Hz, typical |
| ≥5 MHz | ≤ -135 dBc/Hz ^a | ≤ -139 dBc/Hz, typical |
| ≥10 MHz | ≤ -137 dBc/Hz ^a | ≤ -141 dBc/Hz, typical |
| Residual FM | | |
| 1 kHz RBW, 1 kHz VBW (<i>Option 1D5</i>) | ≤150 Hz × N p-p in 100 ms ≤100 Hz × N p-p in 100 ms | |
| 10 Hz RBW, 10 Hz VBW (<i>Option 1DR and 1D5</i>) | ≤2 Hz × N p-p in 20 ms | |
| 10 Hz RBW, 10 Hz VBW (<i>Option 1DR</i>) | | ≤10 Hz × N p-p in 20 ms, characteristic |

| | Specifications | Supplemental Information |
|--|------------------------|---|
| System-Related Sidebands, offset from CW signal ≥30 kHz | ≤ -65 dBc ^a | |
| Line-Related Sidebands, offset from CW signal (<i>Option 1DR</i>) <300 Hz | | ≤ -50 dBc ^a , characteristic |
| >300 Hz to 30 kHz | | ≤ -55 dBc ^a , characteristic |

a. Add 20 Log(N) for frequencies > 6.7 GHz.

Noise Sidebands Normalized to 1 Hz Versus Offset from Carrier

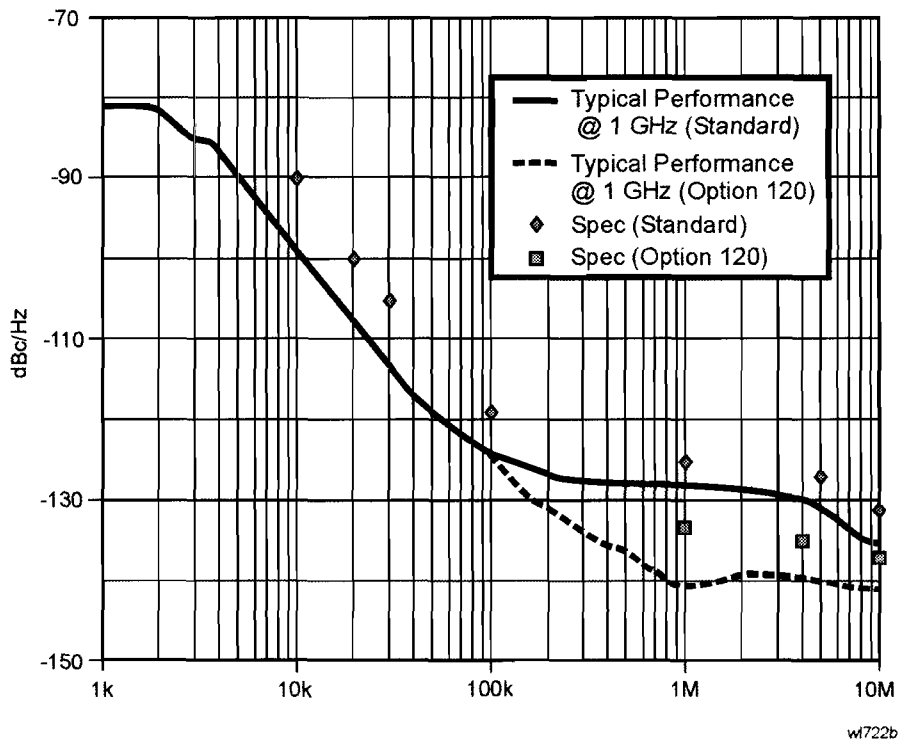

Amplitude

Amplitude specifications do not apply for the negative peak detector mode.

| | Specifications | Supplemental Information |
|--------------------------|---|--------------------------|
| Measurement Range | Displayed Average Noise Level to Maximum Safe Input Level | |
| Input Attenuator Range | 0 to 65 dB, in 5 dB steps | |

| | Specifications | Supplemental Information |
|--|-----------------|--------------------------|
| Maximum Safe Input Level | | |
| Average Continuous Power (Input attenuator setting ≥ 5 dB) | +30 dBm (1 W) | |
| Peak Pulse Power (for $< 10 \mu\text{sec}$ pulse width, $< 1\%$ duty cycle, and input attenuation ≥ 30 dB) | +50 dBm (100 W) | |
| dc | 0 Vdc | |
| (Option UKB) | | |
| dc coupled | 0 Vdc | |
| ac coupled | 50 Vdc | |

| | Specifications | Supplemental Information |
|---|----------------|--------------------------|
| 1 dB Gain Compression | | |
| Total power at input mixer ^{a,b} | | |
| 50 MHz to 3.0 GHz | 0 dBm | |
| 3.0 GHz to 6.7 GHz | 0 dBm | |
| 6.7 GHz to 13.2 GHz | -3 dBm | |
| 13.2 GHz to 26.5 GHz | -5 dBm | |
| Preamp On (Option 1DS) | | |
| Total power at the preamp ^c | | -20 dBm, characteristic |

- Mixer power level (dBm) = input power (dBm) – input attenuation (dB).
- For resolution bandwidths 1 kHz to 30 kHz, the maximum input signal amplitude must be \leq reference level +10 dB.
- Total power at the preamp (dBm) = total power at the input (dBm) – input attenuation (dB).

| | Specifications | | Supplemental Information | |
|--|------------------------|---------------------------------------|-------------------------------------|---|
| | | | | |
| Displayed Average Noise Level (Input terminated, 0 dB attenuation, sample detector, Reference Level = -70 dBm) | | | | |
| | 1 kHz RBW 30 Hz VBW | 10 Hz RBW 1 Hz VBW (Option IDR) | 1 kHz RBW 30 Hz VBW (typical) | 10 Hz RBW 1 Hz VBW (Option IDR) (typical) |
| 9 kHz to 100 kHz | | | | ≤ -109 dBm |
| 100 kHz to 1 MHz | | | | ≤ -135 dBm |
| 1 MHz to 10 MHz | | | ≤ -117 dBm | ≤ -137 dBm |
| 1 MHz to 10 MHz (Option I20) | | | ≤ -120 dBm | ≤ -139 dBm |
| 10 MHz to 1.0 GHz | ≤ -116 dBm | ≤ -135 dBm | ≤ -119 dBm | ≤ -139 dBm |
| 1.0 GHz to 2.0 GHz | ≤ -116 dBm | ≤ -135 dBm | ≤ -120 dBm | ≤ -140 dBm |
| 2.0 GHz to 3.0 GHz | ≤ -112 dBm | ≤ -131 dBm | ≤ -118 dBm | ≤ -138 dBm |
| 3.0 GHz to 6.0 GHz | ≤ -112 dBm | ≤ -131 dBm | ≤ -118 dBm | ≤ -138 dBm |
| 6.0 GHz to 12 GHz | ≤ -111 dBm | ≤ -130 dBm | ≤ -117 dBm | ≤ -137 dBm |
| 12 GHz to 22 GHz | ≤ -107 dBm | ≤ -126 dBm | ≤ -114 dBm | ≤ -134 dBm |
| 22 GHz to 26.5 GHz | ≤ -106 dBm | ≤ -125 dBm | ≤ -112 dBm | ≤ -132 dBm |
| Preamp On (Option IDS) | 1 kHz RBW 30 Hz VBW | 10 Hz RBW 1 Hz VBW (Option IDR) | 1 kHz RBW 30 Hz VBW (typical) | 10 kHz RBW 1 Hz VBW (Option IDR) (typical) |
| 0 to 55 °C | | | | |
| 10 MHz to 1.0 GHz | ≤ -131 dBm | ≤ -150 dBm | | |
| 1.0 GHz to 2.0 GHz | ≤ -131 dBm | ≤ -150 dBm | | |
| 2.0 GHz to 3.0 GHz | ≤ -127 dBm | ≤ -146 dBm | | |
| 20 to 30 °C | | | | |
| 1 MHz to 10 MHz (Option UKB) (dc coupled) | | | ≤ -135 dBm | ≤ -155 dBm |
| 10 MHz to 1.0 GHz | ≤ -132 dBm | ≤ -151 dBm | ≤ -137 dBm | ≤ -157 dBm |
| 1.0 GHz to 2.0 GHz | ≤ -132 dBm | ≤ -151 dBm | ≤ -135 dBm | ≤ -155 dBm |
| 2.0 GHz to 3.0 GHz | ≤ -130 dBm | ≤ -149 dBm | ≤ -132 dBm | ≤ -152 dBm |

Agilent E4407B Specifications and Characteristics
Amplitude

| | Specifications | | Supplemental Information | |
|---------------------------------------|----------------|--|---|---|
| External Mixing (<i>Option AYZ</i>) | | | 1 kHz RBW 30 Hz VBW ≤ -134 dBm + external mixer conversion loss, characteristic | 10 Hz RBW 1 Hz VBW (<i>Option IDR</i>) ≤ -153 dBm + external mixer conversion loss, characteristic |

| | Specifications | Supplemental Information |
|---|--|--------------------------|
| Display Range | | |
| Log Scale | Ten divisions displayed; 0.1, 0.2, 0.5 dB/division and 1 to 20 dB/division in 1 dB steps | |
| RBW \geq 1 kHz | Calibrated 0 to -85 dB from Reference Level | |
| RBW \leq 300 Hz (<i>Option IDR</i>) | Calibrated 0 to -120 dB ^a from Reference Level | |
| Linear Scale | Ten divisions | |
| Scale Units | dBm, dBmV, dB μ V, dB μ A, A, V, and W | |
| (<i>Option BAA, 106</i>) | Add Hz | |

- a. 0 to -70 dB range when span = 0 Hz, or when IF Gain fixed:
(:DISPlay:WINDow:TRACe:Y[:SCALE]:LOG:RANGE:AUTO OFF).

| | Specifications | Supplemental Information |
|---|--------------------------|--------------------------|
| Marker Readout Resolution | | |
| Log scale | | |
| RBW \geq 1 kHz | | |
| 0 to -85 dB from ref level | 0.04 dB | |
| RBW \leq 300 Hz (<i>Option IDR</i>) | | |
| 0 to -120 dB from ref level | 0.04 dB | |
| Linear scale | 0.01% of Reference Level | |
| Fast Sweep Times for Zero Span | | |

| | Specifications | Supplemental Information |
|--|---|--------------------------|
| <p><i>(Option AXX)</i> For sweep times $\frac{\text{sweep points} - 1}{20 \text{ MHz}}$ to $\frac{\text{sweep points} - 1}{100 \text{ kHz}}$</p> <p>Log 0 to -85 dB from ref level</p> <p>Linear</p> | <p>0.3 dB</p> <p>0.3% of Reference Level for linear scale</p> | |
| <p><i>(Option B7D)</i> For sweep times $\frac{\text{sweep points} - 1}{40 \text{ MHz}}$ to $\frac{\text{sweep points} - 1}{100 \text{ kHz}}$</p> <p>Log 0 to -85 dB from ref level</p> <p>Linear</p> | <p>0.2 dB</p> <p>0.2% of Reference Level for linear scale</p> | |

| | Specifications | Supplemental Information |
|---|---|--|
| <p>Frequency Response</p> <p>Absolute^a/Relative</p> <p>10 dB attenuation</p> <p>9 kHz to 3.0 GHz</p> <p>20 to 30 °C</p> <p>0 to 55 °C</p> <p>800 MHz to 1.0 GHz</p> <p>20 to 30 °C</p> <p>0 to 55 °C</p> <p>1.7 GHz to 2.0 GHz</p> <p>20 to 30 °C</p> <p>0 to 55 °C</p> | <p>±0.46 dB</p> <p>±0.76 dB</p> <p>±0.46 dB</p> <p>±0.76 dB</p> <p>±0.46 dB</p> <p>±0.76 dB</p> | <p>±0.14 dB, typical</p> <p>±0.10 dB, typical</p> <p>±0.08 dB, typical</p> |

Agilent E4407B Specifications and Characteristics
Amplitude

| | Specifications | Supplemental Information |
|---|----------------|--------------------------|
| <i>(Option UKB)</i> | | |
| (dc coupled) | | |
| 100 Hz to 3.0 GHz | | |
| 20 to 30 °C | ±0.5 dB | |
| 0 to 55 °C | ±1.0 dB | |
| 30 Hz to 3.0 GHz | | |
| 20 to 30 °C | | ±0.5 dB, characteristic |
| 0 to 55 °C | | ±1.0 dB, characteristic |
| (ac coupled) | | |
| 10 MHz to 3.0 GHz | | |
| 20 to 30 °C | ±0.5 dB | |
| 0 to 55 °C | ±1.0 dB | |
| 800 MHz to 1.0 GHz | | |
| 20 to 30 °C | ±0.5 dB | |
| 0 to 55 °C | ±1.0 dB | |
| 1.7 GHz to 2.0 GHz | | |
| 20 to 30 °C | ±0.5 dB | |
| 0 to 55 °C | ±1.0 dB | |
| Absolute ^a /Relative Preamp On | | |
| <i>(Option IDS)</i> | | |
| 0 dB attenuation | | |
| 1 MHz to 3.0 GHz | | |
| 20 to 30 °C | ±1.5 dB | ±0.47 dB, typical |
| 0 to 55 °C | ±2.0 dB | |
| 800 MHz to 1.0 GHz | | |
| 20 to 30 °C | ±1.5 dB | ±0.35 dB, typical |
| 0 to 55 °C | ±2.0 dB | |
| 1.7 GHz to 2.0 GHz | | |
| 20 to 30 °C | ±1.5 dB | ±0.26 dB, typical |
| 0 to 55 °C | ±2.0 dB | |

| | Specifications | Supplemental Information |
|---|----------------|--------------------------|
| <i>(Option UKB)</i> (dc coupled) | | |
| 1 MHz to 3.0 GHz | | |
| 20 to 30 °C | ±1.5 dB | ±0.47 dB, typical |
| 0 to 55 °C | ±2.0 dB | |
| (ac coupled) | | |
| 10 MHz to 3.0 GHz | | |
| 20 to 30 °C | ±1.5 dB | |
| 0 to 55 °C | ±2.0 dB | |
| 800 MHz to 1.0 GHz | | |
| 20 to 30 °C | ±1.5 dB | ±0.35 dB, typical |
| 0 to 55 °C | ±2.0 dB | |
| 1.7 GHz to 2.0 GHz | | |
| 20 to 30 °C | ±1.5 dB | ±0.26 dB, typical |
| 0 to 55 °C | ±2.0 dB | |
| Preselector centered for frequency >3.0 GHz <i>(Option UKB)</i> (ac or dc coupled) | | |
| 10 dB attenuation | | |
| 3.0 GHz to 6.7 GHz | | |
| Absolute ^a | | |
| 20 to 30 °C | ±1.5 dB | ±0.38 dB, typical |
| 0 to 55 °C | ±2.5 dB | |
| Relative | | |
| 20 to 30 °C | ±1.3 dB | |
| 0 to 55 °C | ±1.5 dB | |
| 6.7 GHz to 13.2 GHz | | |
| Absolute ^a | | |
| 20 to 30 °C | ±2.0 dB | ±0.68 dB, typical |
| 0 to 55 °C | ±3.0 dB | |

Agilent E4407B Specifications and Characteristics
Amplitude

| | Specifications | Supplemental Information |
|-----------------------|----------------|--------------------------|
| Relative | | |
| 20 to 30 °C | ±1.8 dB | |
| 0 to 55 °C | ±2.0 dB | |
| 13.2 GHz to 26.5 GHz | | |
| Absolute ^a | | |
| 20 to 30 °C | ±2.0 dB | ±0.86 dB, typical |
| 0 to 55 °C | ±3.0 dB | |
| Relative | | |
| 20 to 30 °C | ±1.8 dB | |
| 0 to 55 °C | ±2.0 dB | |

a. Absolute frequency response values are referenced to the amplitude at 50 MHz.

| | Specifications | Supplemental Information |
|--|--|--------------------------|
| Input Attenuation Switching Uncertainty at 50 MHz | | |
| Attenuator Setting | | |
| 0 dB to 5 dB | ±0.3 dB | |
| 10 dB | Reference | |
| 15 dB | ±0.3 dB | |
| 20 to 65 dB attenuation | ±(0.1 dB + 0.01 × Attenuator Setting) | |

| Attenuation Accuracy Relative to the 10 dB Attenuator Setting, Characteristic | | | | | |
|---|-----------------|--------------|-------------|-----------|-------------|
| Attenuation | Frequency Range | | | | |
| | dc–3 GHz | 3.0–13.2 GHz | 13.2–19 GHz | 19–22 GHz | 22–26.5 GHz |
| 0 dB | ±0.3 dB | ±0.5 dB | ±0.8 dB | ±0.9 dB | ±1.0 dB |
| 5 dB | ±0.3 dB | ±0.5 dB | ±0.8 dB | ±0.9 dB | ±1.0 dB |
| 10 dB | Reference | Reference | Reference | Reference | Reference |
| 15 dB | ±0.4 dB | ±0.5 dB | ±0.8 dB | ±1.0 dB | ±1.5 dB |
| 20 dB | ±0.4 dB | ±0.5 dB | ±0.8 dB | ±1.0 dB | ±1.5 dB |
| 25 dB | ±0.5 dB | ±0.6 dB | ±0.8 dB | ±1.2 dB | ±2.0 dB |

| Attenuation Accuracy Relative to the 10 dB Attenuator Setting, Characteristic | | | | | |
|---|-----------------|--------------|-------------|-----------|-------------|
| Attenuation | Frequency Range | | | | |
| | dc–3 GHz | 3.0–13.2 GHz | 13.2–19 GHz | 19–22 GHz | 22–26.5 GHz |
| 30 dB | ±0.5 dB | ±0.6 dB | ±0.8 dB | ±1.2 dB | ±2.0 dB |
| 35 dB | ±0.6 dB | ±0.7 dB | ±1.0 dB | ±1.8 dB | ±3.0 dB |
| 40 dB | ±0.6 dB | ±0.7 dB | ±1.0 dB | ±1.8 dB | ±3.0 dB |
| 45 dB | ±0.7 dB | ±1.0 dB | ±1.3 dB | ±2.2 dB | ±3.4 dB |
| 50 dB | ±0.7 dB | ±1.0 dB | ±1.3 dB | ±2.2 dB | ±3.4 dB |
| 55 dB | ±0.9 dB | ±1.1 dB | ±1.6 dB | ±2.7 dB | ±3.5 dB |
| 60 dB | ±0.9 dB | ±1.1 dB | ±1.6 dB | ±2.7 dB | ±3.5 dB |
| 65 dB | ±1.0 dB | ±1.6 dB | ±2.0 dB | ±3.2 dB | ±3.8 dB |

| | Specifications | Supplemental Information |
|----------------------------|----------------|---|
| Preamp (Option IDS) | | Refer also to Displayed Average Noise Level specification |
| Gain | | +20 dB, nominal ^a |
| Noise figure | | 5 dB, characteristic |

a. Amplifier is between the input attenuator and the input mixer.

| | Specifications | Supplemental Information |
|-------------------------------------|---|--------------------------|
| Absolute Amplitude Accuracy | | |
| At reference settings ^a | ±0.34 dB | ±0.13 dB, typical |
| Preamp On ^b (Option IDS) | ±0.37 dB | ±0.14 dB, typical |
| External Mixing (Option AYZ) | IF INPUT absolute amplitude accuracy + external mixer conversion loss accuracy ^c | |

Agilent E4407B Specifications and Characteristics
Amplitude

| | Specifications | Supplemental Information |
|--|--|--------------------------|
| Overall Amplitude Accuracy ^d 20 to 30 °C | $\pm (0.54 \text{ dB} + \text{Absolute Frequency Response})$ | |

- Settings are: reference level -20 dBm; input attenuation 10 dB; dc coupled (*Option UKB*); center frequency 50 MHz; RBW 1 kHz; VBW 1 kHz; scale linear or log; span 2 kHz; sweep time coupled, sample detector, signal at reference level.
- Settings are: reference level -30 dBm; input attenuation 0 dB; dc coupled (*Option UKB*); center frequency 50 MHz; RBW 1 kHz; VBW 1 kHz; scale linear or log; span 2 kHz; sweep time coupled, signal at reference level.
- Preselector centered with HP/Agilent 11974-Series mixers.
- For reference level 0 to -50 dBm; input attenuation 10 dB; dc coupled (*Option UKB*); RBW 1 kHz; VBW 1 kHz; scale log, log range 0 to -50 dB from reference level; sweep time coupled; signal input 0 to -50 dBm; span ≤ 20 kHz; internal mixing.

| | Specifications | Supplemental Information |
|---|----------------|-------------------------------|
| RF Input VSWR (at tuned frequency) | | |
| Attenuator setting 0 dB | | |
| 9 kHz to 26.5 GHz | | $\leq 3.0:1$, characteristic |
| Attenuator setting 5 dB | | |
| 9 kHz to 100 kHz | | $\leq 2.0:1$, characteristic |
| 100 kHz to 6.7 GHz | | $\leq 1.4:1$, characteristic |
| 6.7 GHz to 13.2 GHz | | $\leq 1.7:1$, characteristic |
| 13.2 GHz to 22.0 GHz | | $\leq 2.3:1$, characteristic |
| 22.0 GHz to 26.5 GHz | | $\leq 2.6:1$, characteristic |
| Attenuator setting 10 to 65 dB | | |
| 9 kHz to 6.7 GHz | | $\leq 1.3:1$, characteristic |
| 6.7 GHz to 13.2 GHz | | $\leq 1.5:1$, characteristic |
| 13.2 GHz to 22.0 GHz | | $\leq 2.0:1$, characteristic |
| 22.0 GHz to 26.5 GHz | | $\leq 2.2:1$, characteristic |

| | Specifications | Supplemental Information | |
|--------------------------------|----------------|----------------------------------|----------------|
| <i>(Option UKB)</i> | | characteristic | characteristic |
| Attenuator setting 0 dB | | (dc coupled) | (ac coupled) |
| 100 Hz to 100 kHz | | $\leq 1.1:1$ | |
| 100 kHz to 3 GHz | | $\leq 3.0:1$ | $\leq 3.0:1$ |
| 100 kHz to 6.7 GHz | | $\leq 1.4:1$, characteristic | |
| 6.7 GHz to 13.2 GHz | | $\leq 1.7:1$, characteristic | |
| 13.2 GHz to 22.0 GHz | | $\leq 2.3:1$, characteristic | |
| 22.0 GHz to 26.5 GHz | | $\leq 2.6:1$, characteristic | |
| Attenuator setting 5 dB | | (dc coupled) | (ac coupled) |
| 100 Hz to 100 kHz | | $\leq 1.1:1$ | |
| 100 kHz to 300 kHz | | $\leq 1.1:1$ | $\leq 2.3:1$ |
| 300 kHz to 1.0 MHz | | $\leq 1.1:1$ | $\leq 1.6:1$ |
| 1.0 MHz to 3.0 GHz | | $\leq 1.4:1$ | $\leq 1.4:1$ |
| 100 kHz to 6.7 GHz | | $\leq 1.4:1$, characteristic | |
| 6.7 GHz to 13.2 GHz | | $\leq 1.7:1$, characteristic | |
| 13.2 GHz to 22.0 GHz | | $\leq 2.3:1$, characteristic | |
| 22.0 GHz to 26.5 GHz | | $\leq 2.6:1$, characteristic | |
| Attenuator setting 10 to 65 dB | | (dc coupled) | (ac coupled) |
| 100 Hz to 100 kHz | | $\leq 1.1:1$ | |
| 100 kHz to 300 kHz | | $\leq 1.1:1$ | $\leq 2.1:1$ |
| 300 kHz to 1.0 MHz | | $\leq 1.1:1$ | $\leq 1.5:1$ |
| 1.0 MHz to 3.0 GHz | | $\leq 1.2:1$ | $\leq 1.2:1$ |
| 100 kHz to 6.7 GHz | | $\leq 1.4:1$, characteristic | |
| 6.7 GHz to 13.2 GHz | | $\leq 1.7:1$, characteristic | |

Agilent E4407B Specifications and Characteristics
Amplitude

| | Specifications | Supplemental Information | |
|----------------------|----------------|---------------------------|--|
| 13.2 GHz to 22.0 GHz | | ≤2.3:1, characteristic | |
| 22.0 GHz to 26.5 GHz | | ≤2.6:1, characteristic | |

| | Specifications | Supplemental Information | |
|---|----------------|--------------------------|--|
| Auto Alignment^a Sweep-to-sweep variation | | ±0.1 dB, characteristic | |

a. Set **Auto Align** to **Off** and use **Align Now, All** to eliminate this variation.

| | Specifications | Supplemental Information | |
|--|----------------|--------------------------|--|
| Resolution Bandwidth Switching Uncertainty (at Reference Level) | | | |
| 1 kHz RBW | Reference | | |
| 3 kHz to 3 MHz RBW | ±0.3 dB | | |
| 5 MHz RBW | ±0.6 dB | | |
| 10 Hz to 300 Hz RBW (Option IDR) | ±0.3 dB | | |

| | Specifications | Supplemental Information | |
|--|--|--------------------------|--|
| Reference Level | | | |
| Range | –149.9 dBm to maximum mixer level + attenuator setting | | |
| Resolution | | | |
| Log Scale | ±0.1 dB | | |
| Linear Scale | ±0.12% of Reference Level | | |
| Accuracy (at a fixed frequency, a fixed attenuator, and referenced to –30 dBm (–10 dBm, Preamp On (Option IDS))) | | | |
| Reference Level (dBm) – input attenuator setting (dB) + preamp gain (dB) | | | |
| –10 dBm to > –60 dBm | ±0.3 dB | | |
| –60 dBm to > –85 dBm | ±0.5 dB | | |
| –85 dBm to –90 dBm | ±0.7 dB | | |

| | Specifications | Supplemental Information |
|--|----------------------------------|--------------------------|
| Display Scale Switching Uncertainty | | |
| Switching between Linear and Log | ± 0.15 dB at reference level | |
| Log Scale Switching | No error | |

| | Specifications | Supplemental Information |
|---|---|------------------------------|
| Display Scale Fidelity | | |
| Log Maximum Cumulative | | |
| RBW ≥ 1 kHz | | |
| dB Below Reference Level | | |
| 0 dB Reference | 0 dB | |
| > 0 to 10 dB | ± 0.22 dB | ± 0.08 dB, typical |
| > 10 to 20 dB | ± 0.24 dB | ± 0.09 dB, typical |
| > 20 to 30 dB | ± 0.26 dB | ± 0.10 dB, typical |
| > 30 to 40 dB | ± 0.40 dB | ± 0.23 dB, typical |
| > 40 to 50 dB | ± 0.57 dB | ± 0.35 dB, typical |
| > 50 to 60 dB | ± 0.57 dB | ± 0.35 dB, typical |
| > 60 to 70 dB | ± 0.66 dB | ± 0.39 dB, typical |
| > 70 to 80 dB | ± 0.66 dB | ± 0.46 dB, typical |
| > 80 to 85 dB | ± 1.15 dB | ± 0.79 dB, typical |
| RBW ≤ 300 Hz (<i>Option 1DR</i>) | | |
| Span > 0 Hz | | |
| Auto range On | | |
| 0 to 98 dB below reference level | $\pm(0.3 \text{ dB} + 0.01 \times \text{dB from reference level})$ | |
| > 98 to 120 dB below reference level | | ± 2.0 dB, characteristic |
| Auto range Off | | |
| 0 to 60 dB below reference level | $\pm(0.3 \text{ dB} + 0.015 \times \text{dB from reference level})$ | |
| > 60 to 70 dB below reference level | ± 1.5 dB | |

Agilent E4407B Specifications and Characteristics
Amplitude

| | Specifications | Supplemental Information |
|---|---|--------------------------|
| Span = 0 Hz ^a | | |
| 0 to 60 dB below reference level | $\pm(0.3 \text{ dB} + 0.015 \times \text{dB from reference level})$ | |
| > 60 to 70 dB below reference level | $\pm 1.5 \text{ dB}$ | |
| Log Incremental Accuracy | | |
| 0 to 80 dB ^b below reference level | $\pm 0.4 \text{ dB/4 dB}$ | |
| Linear Accuracy | $\pm 2\%$ of Reference Level | |

- a. The SCPI command for auto range off is:
(:DISPlay:WINDow:TRACe:Y[:SCALE]:LOG:RANGe:AUTO OFF)
- b. 0 to -50 dB for RBWs \leq 300 Hz and span = 0 Hz, or when auto ranging is off.

| | Specifications | Supplemental Information |
|--|---|---|
| Spurious Responses | | |
| Second Harmonic Distortion | | |
| Input Signal | | |
| 10 MHz to 500 MHz | $< -65 \text{ dBc}$ for -30 dBm signal at input mixer ^a | +35 dBm SHI (second harmonic intercept) |
| 500 MHz to 1.5 GHz | $< -75 \text{ dBc}$ for -30 dBm signal at input mixer ^a | +45 dBm SHI |
| 1.5 GHz to 2.0 GHz | $< -85 \text{ dBc}$ for -10 dBm signal at input mixer ^a | +75 dBm SHI |
| 2.0 GHz to 3.35 GHz | $< -100 \text{ dBc}^b$ for -10 dBm signal at input mixer ^a | +90 dBm SHI |
| 3.35 GHz to 6.6 GHz | $< -100 \text{ dBc}^b$ for -10 dBm signal at input mixer ^a | +90 dBm SHI |
| 6.6 GHz to 13.25 GHz | $< -100 \text{ dBc}^b$ for -10 dBm signal at input mixer ^a | +90 dBm SHI |
| Preamp On (<i>Option 1DS</i>) 10 MHz to 1.5 GHz | | -5 dBm SHI, characteristic |

| | Specifications | Supplemental Information |
|--|--|--|
| Third Order Intermodulation Distortion | | |
| 10 MHz to 100 MHz | | +7 dBm TOI (third order intercept), characteristic |
| 100 MHz to 3 GHz | < -85 dBc for two -30 dBm signals at input mixer ^a and >50 kHz separation | +12.5 dBm TOI +16 dBm TOI, typical |
| 3.0 GHz to 6.7 GHz | < -82 dBc for two -30 dBm signals at input mixer ^a and >50 kHz separation | +11 dBm TOI +18 dBm TOI, typical |
| 6.7 GHz to 13.2 GHz | < -75 dBc for two -30 dBm signals at input mixer ^a and >50 kHz separation | +7.5 dBm TOI +12 dBm TOI, typical |
| 13.2 GHz to 26.5 GHz | < -75 dBc for two -30 dBm signals at input mixer ^a and >50 kHz separation | +7.5 dBm TOI +11 dBm TOI, typical |
| Preamp On (<i>Option 1DS</i>) 10 MHz to 3 GHz | | -16 dBm TOI, characteristic |
| Other Input Related Spurious | | |
| Inband Responses | | |
| >30 kHz offset | < -65 dBc for -20 dBm signal at input mixer ^a | |
| Out-of-band Responses | < -80 dBc for -10 dBm signal at input mixer ^a | |

a. Mixer power level (dBm) = input power (dBm) – input attenuation (dB).

b. or signal below displayed average noise level.

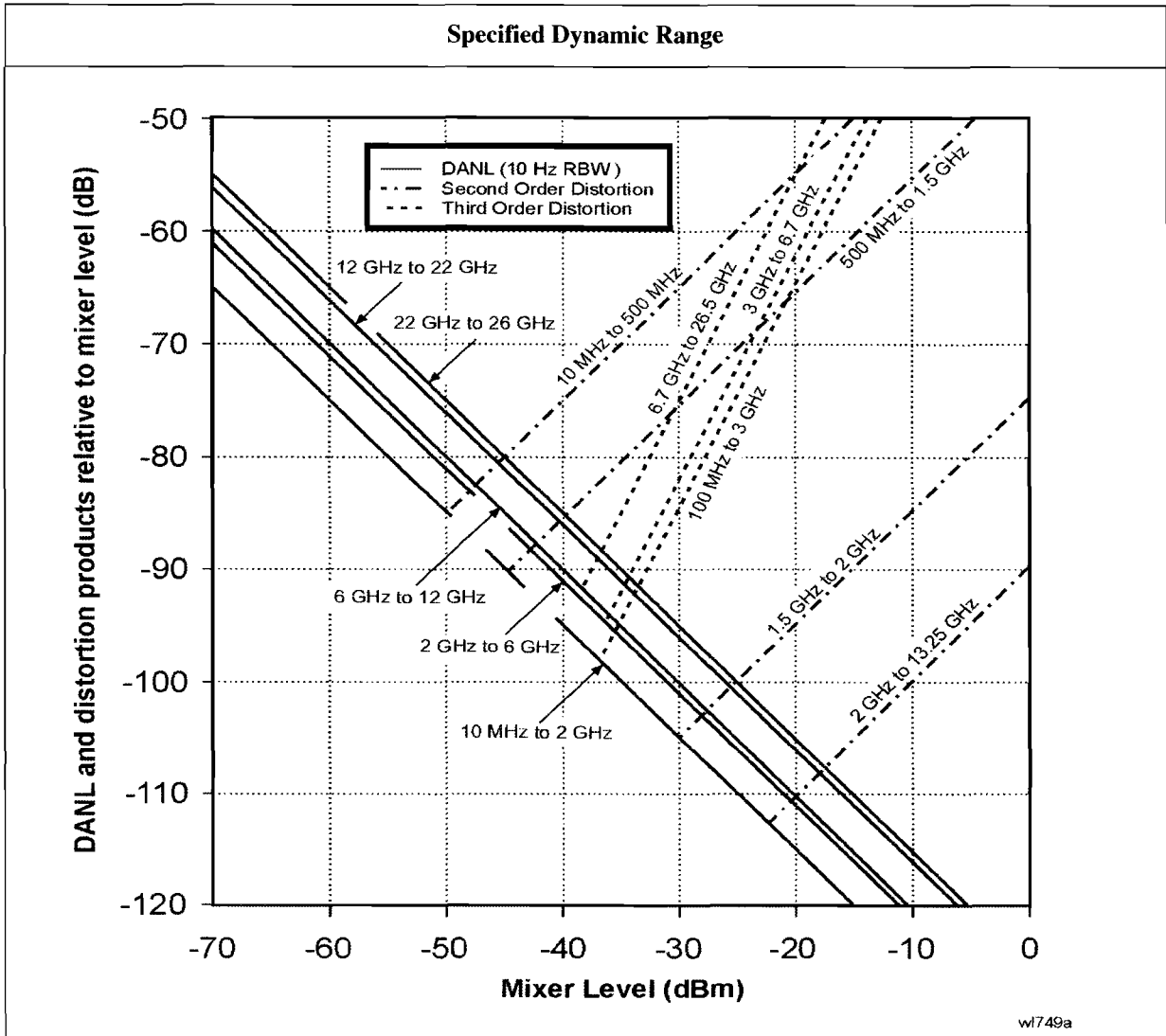

| | Specifications | Supplemental Information |
|---|----------------|--------------------------|
| Residual Responses (Input terminated and 0 dB attenuation) 150 kHz to 6.7 GHz | < -90 dBm | |

Options

Time Gated Spectrum Analysis (Option 1D6)

| | Specifications | Supplemental Information |
|---|---|---|
| Gate Delay | | |
| Range | 1 μ s to 400 s | |
| Accuracy | $\pm(500 \text{ ns} + (0.01\% \times (\text{maximum of gate delay or length})))$ | From gate trigger input to positive edge of gate output |
| Gate Length | | |
| Range | 1 μ s to 400 s | |
| Accuracy | $\pm(500 \text{ ns} + (0.01\% \times (\text{maximum of gate delay or length})))$ | From positive edge to negative edge of gate output |
| Resolution | $((\text{maximum of gate delay or length in seconds})/65000)$ rounded up to nearest μ s | Dependent on the greater of gate delay or gate length |
| Additional Amplitude Error^a | | |
| Log Scale | $\pm 0.2 \text{ dB}$ | |
| Linear Scale | $\pm 0.1\%$ of reference level | |

a. While in gate mode.

Tracking Generator (Option 1DN)

The spectrum analyzer/tracking generator combination will meet its specification after a cable (8120-5148) and adapter are connected between RF OUT and INPUT and **Align Now, TG** has been run.

| | Specifications | Supplemental Information |
|----------------|----------------|--------------------------|
| Warm-up | 5 minutes | |

| | Specifications | Supplemental Information |
|-------------------------------|------------------|--------------------------|
| Output Frequency Range | 9 kHz to 3.0 GHz | |

| | Specifications | Supplemental Information |
|------------------------------|----------------|---|
| Minimum Resolution BW | 1 kHz | Not usable with resolution bandwidths ≤ 300 Hz (Option 1DR) |

| | Specifications | Supplemental Information |
|---|--------------------------|--------------------------|
| Output Power Level | | |
| Range | -2 to -66 dBm | |
| Resolution | 0.1 dB | |
| Absolute Accuracy (at 50 MHz with coupled source attenuator, referenced to -20 dBm) | ± 0.75 dB | |
| Vernier | | |
| Range | 8 dB | |
| Accuracy (with coupled source attenuator, 50 MHz, -20 dBm) | | |
| Incremental | ± 0.2 dB/dB | |
| Cumulative | ± 0.5 dB, total | |
| Output Attenuator Range | 0 to 56 dB in 8 dB steps | |

| | Specifications | Supplemental Information |
|-----------------------------------|----------------|---------------------------------------|
| Maximum Safe Reverse Level | | +30 dBm (1 W), 50 Vdc, characteristic |

| | Specifications | Supplemental Information |
|---------------------------|---|--------------------------|
| Output Power Sweep | | |
| Range | (-10 to -2 dBm) – (Source Attenuator Setting) | |
| Resolution | 0.1 dB | |
| Accuracy (zero span) | <1 dB peak-to-peak | |

| | Specifications | Supplemental Information |
|-------------------------------|----------------|--------------------------|
| Output Flatness | | |
| Referenced to 50 MHz, -20 dBm | | |
| 9 kHz to 10 MHz | ±3 dB | |
| 10 MHz to 3 GHz | ±2 dB | |

| | Specifications | Supplemental Information |
|---|----------------|--------------------------|
| Spurious Outputs | | |
| (-2 dBm output) | | |
| Harmonic Spurs | | |
| TG Output 9 kHz to 20 kHz | ≤ -15 dBc | |
| TG Output 20 kHz to 3 GHz | ≤ -25 dBc | |
| Non-harmonic Spurs | | |
| TG Output 9 kHz to 2 GHz | ≤ -27 dBc | |
| TG Output 2 GHz to 3 GHz | ≤ -23 dBc | |
| LO Feedthrough | | |
| LO Frequency 3.921409 GHz to 6.9214 GHz | ≤ -16 dBm | |

| | Specifications | Supplemental Information |
|----------------------|---|--------------------------|
| Dynamic Range | Maximum Output Power Level – Displayed Average Noise Level | |

Agilent E4407B Specifications and Characteristics
Options

| | Specifications | Supplemental Information |
|------------------------|----------------|--|
| Output Tracking | | |
| Drift | | 1.5 kHz/5 minute, characteristic |
| Swept Tracking Error | | Usable in 1 kHz RBW after 5 minutes of warm-up |

| | Specifications | Supplemental Information |
|-------------------------------|----------------|----------------------------|
| RF Power-Off Residuals | | |
| 9 kHz to 3 GHz | | < -120 dBm, characteristic |

| | Specifications | Supplemental Information |
|--|----------------|--------------------------|
| Output Attenuator Repeatability | | |
| 9 kHz to 300 MHz | | ±0.1 dB, characteristic |
| 300 MHz to 2 GHz | | ±0.2 dB, characteristic |
| 2 GHz to 3 GHz | | ±0.3 dB, characteristic |

| | Specifications | Supplemental Information |
|--------------------|----------------|--------------------------|
| Output VSWR | | |
| 0 dB attenuation | | <2.0:1, characteristic |
| ≥ 8 dB attenuation | | <1.5:1, characteristic |

| | Specifications | Supplemental Information |
|-----------------------------------|----------------|--------------------------|
| Output Attenuator Accuracy | | |
| 0 dB | Reference | ±0.5 dB, characteristic |
| 8 dB | | ±0.5 dB, characteristic |
| 16 dB | | |
| 24 dB | | ±0.5 dB, characteristic |
| 32 dB | | ±0.6 dB, characteristic |
| 40 dB | | ±0.8 dB, characteristic |
| 48 dB | | ±1.0 dB, characteristic |
| 56 dB | | ±1.1 dB, characteristic |

Tracking Generator Output Accuracy

Relative Accuracy (Referred to -20 dBm) =
Output Attenuator Accuracy + Vernier Accuracy + Output Flatness

Absolute Accuracy =
Relative Accuracy (Referred to -20 dBm) + Absolute Accuracy at 50 MHz

External Mixing (Option AYZ)

| | Specifications | | Supplemental Information |
|--|----------------|-----------|---|
| LO OUTPUT | | | |
| Frequency Range | 2.9 to 7.1 GHz | | |
| Power | | | When connected to external mixers with an HP/Agilent 5061-5458 cable, provides 14.5 to 16 dBm at the mixer, characteristic. |
| 2.9 to 6.1 GHz | 15.5 to 17 dBm | | |
| 20 to 30°C | | | |
| 0 to 55°C | 15 to 17.5 dBm | | |
| 2.9 to 7.1 GHz | 13 to 17.5 dBm | | |
| VSWR | | | <1.9:1, characteristic |
| IF INPUT | | | |
| Frequency Range | | | 321.4 MHz ±5 MHz, characteristic |
| Maximum Safe Input Level | | | |
| ac | | | 10 dBm, characteristic |
| dc | | | ±10 V, characteristic |
| VSWR | | | <1.9:1, characteristic |
| Absolute Amplitude Accuracy ^a | | | |
| For Reference Levels from -10 to -60 dBm | | | |
| Amplitude Corrections | 20 to 30°C | 0 to 55°C | |
| 15 to 30 dB | ±1.0 dB | ±1.5 dB | |
| >30 to 50 dB | ±1.2 dB | ±1.7 dB | |
| >50 to 60 dB | ±1.4 dB | ±1.9 dB | |
| 1 dB Gain Compression Level ^b | | | -20 dBm, characteristic with -10 dBm reference level |
| Mixer Bias (IF INPUT) | | | |
| Voltage | | | |
| Maximum Range | | | ±3.3 V, characteristic |
| Linear Compliant Range | | | ±2 V, characteristic |

| | Specifications | | Supplemental Information |
|------------------------------|----------------|--|---|
| Current (0 Ω load) | | | |
| Range | ± 10 mA | | |
| Resolution | | | < 20 μ A, characteristic |
| Accuracy | ± 10 mA | | $\pm(3\% + \text{Resolution})$, characteristic |
| Output Impedance | | | 490 Ω , nominal |

- a. Settings are: RBW 1 kHz; VBW 1 kHz; scale linear or log; span 2 kHz; sweep time coupled, sample detector, signal at reference level.
- b. With amplitude corrections 0 dB.

Bluetooth FM Demodulation (Option 106)

The FM demodulation characteristics will apply after an Align Now, FM Demod has been run.

| | Specifications | Supplemental Information |
|-----------------------------|----------------|---|
| Optimum Input Level | | $\geq (-40 \text{ dBm} + \text{attenuator setting} - \text{preamp gain})$ and within 10 dB of the reference level |
| FM Deviation | | |
| Range | | $\pm 200 \text{ kHz}$, nominal |
| Resolution | | Provides 400 Hz display annotation resolution, nominal |
| Accuracy ^a | | $\pm 10 \text{ kHz}$, typical |
| Input level = -30 dBm | | $\pm 4 \text{ kHz}$ with video averaging On and averages ≥ 25 |
| Reference level = -30 dBm | | |
| FM Rate = 500 kHz sine | | |
| VBW = 3 MHz, | | |
| RBW = 5 MHz, | | |
| FM Deviation = 140 kHz | | |
| Offset Error ^a | | $\pm 1 \text{ kHz}$, typical |
| FM Bandwidth (-3 dB) | | 1.2 MHz, nominal |

a. In time domain sweeps (span = 0 Hz).

Bluetooth Measurements Personality (Option 228)

The demodulation related nominals will apply after an Align Now, FM Demod has been run.

| | Specifications | Supplemental Information |
|--------------------------------|--------------------|--------------------------|
| In-Band Frequency Range | | |
| Bluetooth (ISM) Band | 2400 to 2483.5 MHz | |

| | Specifications | Supplemental Information |
|--|---|---|
| Output Power (Option AYX or B7D) | | |
| Range at RF Input | 30 to -40 dBm | |
| (Option IDS) | 30 to -60 dBm | |
| Absolute Amplitude Accuracy | | Appendix , "Absolute Amplitude Accuracy," on page 251 |
| Average type | Video, Power | |
| Average mode | Exponential, Repeat | |
| Trigger source | Video, RF burst ^a , External, Free Run | |
| Burst synch | RF Amplitude, Preamble ^b , None | |

a. Requires Option B7E

b. Requires Option 106 Bluetooth FM demodulation.

| | Specifications | Supplemental Information |
|--|---------------------------------|--|
| Modulation Characteristics^a (Option 106 and AYX or B7D) | | |
| Range at RF Input | 30 to -40 dBm | |
| (Option IDS) | 30 to -60 dBm | |
| FM Deviation | | |
| Range | | ±200 kHz, nominal |
| Accuracy | | ±4 kHz, nominal (25 measurement averages, signal level > -30 dBm) |
| Payload data | 11110000, 10101010, auto-detect | |
| Average mode | Exponential, Repeat | |

Agilent E4407B Specifications and Characteristics
Options

| | Specifications | Supplemental Information |
|----------------|---|--------------------------|
| Trigger source | Video, RF burst ^b , External, Free Run | |
| Burst synch | RF Amplitude, Preamble ^c , None | |
| Limits | $\Delta f_2/\Delta f_1$ lower, Δf_1 max lower/upper Δf_2 | |

- a. The DUT must have frequency hopping disabled.
- b. Requires Option B7E
- c. Requires Option 106 Bluetooth FM demodulation.

| | Specifications | Supplemental Information |
|--|---|---|
| Carrier Frequency Drift ^a (Option 106 and AYX or B7D) | | |
| Range at RF Input | 30 to -40 dBm | |
| (Option 1DS) | 30 to -60 dBm | |
| Measurement range | | ± 100 kHz, nominal |
| Measurement accuracy | | ± 4 kHz, nominal (25 measurement averages, signal level > -30 dBm) |
| Average mode | Exponential, Repeat | |
| Trigger source | Video, RF burst ^b , External, Free Run | |
| Burst synch | Preamble ^c , None | |

- a. The DUT must have frequency hopping disabled.
- b. Requires Option B7E
- c. Requires Option 106 Bluetooth FM demodulation.

| | Specifications | Supplemental Information |
|---|----------------|---|
| Initial Carrier Frequency Tolerance (ICTF) ^a (Option 106 and AYX or B7D) | | |
| Range at RF Input | 30 to -40 dBm | |
| (Option 1DS) | 30 to -60 dBm | |
| Measurement range | | ± 100 kHz, nominal |
| Measurement accuracy | | ± 4 kHz, nominal (25 measurement averages, signal level > -30 dBm) |

| | Specifications | Supplemental Information |
|----------------|---|---------------------------------|
| Average mode | Exponential, Repeat | |
| Trigger source | Video, RF burst ^b , External, Free Run | |
| Burst synch | RF Amplitude, Preamble ^c , None | |
| Limits | ICFT upper/lower | |

- a. The DUT must have frequency hopping disabled.
- b. Requires Option B7E
- c. Requires Option 106 Bluetooth FM demodulation.

FM Demodulation (Option BAA)

The FM demodulation characteristics will apply after an **Align Now, FM Demod** has been run.

| | Specifications | Supplemental Information |
|---|----------------|---|
| Optimum Input Level | | $\geq (-60 \text{ dBm} + \text{attenuator setting} - \text{preamp gain})$ and within 30 dB of the reference level |
| FM Deviation | | |
| Range | | 10 kHz to 1 MHz |
| Resolution | | Provides 1 Hz display annotation resolution |
| FM Deviation Range | | |
| 10 kHz to 40 kHz | | 12 Hz, characteristic |
| >40 kHz to 200 kHz | | 60 Hz, characteristic |
| >200 kHz to 1 MHz | | 300 Hz, characteristic |
| Accuracy ^a | | |
| FM Rate < FM BW/100, VBW $\geq (30 \times \text{FM Rate})$, RBW > the maximum of (30 \times FM deviation) or (30 \times FM Rate) | | < (2% of FM deviation range + 2 \times Resolution), characteristic |
| Offset Error ^a | | 5% of FM Deviation Range + 300 Hz, characteristic |
| FM Bandwidth (-3 dB) | | |
| FM Deviation Range | | |
| 10 kHz to 40 kHz | | 7.5 \times FM deviation range, characteristic |
| >40 kHz to 200 kHz | | 1.3 \times FM deviation range, characteristic |
| >200 kHz to 1 MHz | | 0.3 \times FM deviation range, characteristic |

a. In time domain sweeps (span = 0 Hz).

TV Trigger and Picture On Screen (Option B7B)

Option BAA is required.

| | Specifications | Supplemental Information |
|---|---|--|
| TV Trigger and Picture On Screen | | TV Trigger initiates a sweep of the analyzer after the sync pulse of a selected line of a TV video field. Picture On Screen displays the TV picture on the analyzer display. |
| Amplitude Requirements TV Source: SA | | Top 50% of linear display, characteristic |
| TV Source: EXT VIDEO IN | | 500 mV _{p-p} to 2 V _{p-p} , characteristic |
| Compatible Standards | NTSC-M, NTSC-Japan, PAL-M, PAL-B,D,G,H,I, PAL-N, PAL-N Combination, SECAM-L | |
| Field Selection | Entire frame, even, odd | |
| Sync Polarity | Positive or negative | |
| TV Trigger | | |
| Line Selection | 1 to 525, or 1 to 625, standard dependent | |

cdmaOne Measurement Personality (Option BAC)

Unless otherwise noted, all specifications are with RF input range auto, default cdmaOne measurement settings, and in the in-band frequency range. *Option B72* is required.

| | Specifications | Supplemental Information |
|--------------------------------|--|--------------------------|
| In-Band Frequency Range | | |
| Cellular bands | 824 to 870 MHz 869 to 925 MHz | |
| PCS bands | 1715 to 1780 MHz 1805 to 1870 MHz 1850 to 1910 MHz 1930 to 1990 MHz | |

| | Specifications | Supplemental Information |
|---|----------------------------|---|
| Adjacent Channel Power Ratio^a | | |
| Carrier power range at RF Input | 30 to -20 dBm | |
| Dynamic range ^b | | Referenced to average power of carrier in 1.23 MHz BW |
| Offset Frequency | Integration BW | |
| 750 kHz | 30 kHz | -70.0 dBc, characteristic |
| 885 kHz | 30 kHz | -73.5 dBc, characteristic |
| 1.25625 MHz | 12.5 kHz | -78.0 dBc, characteristic |
| 1.98 MHz | 30 kHz | -75.5 dBc, characteristic |
| 2.75 MHz | 1 MHz | -60.5 dBc, characteristic |
| Relative accuracy ^c | See Display Scale Fidelity | |
| Resolution | 0.01 dB | |

- a. This measurement is available with personality revisions of A.02.00 or later.
- b. IS-97A nominal base station test model levels (fraction of carrier power); Pilot: 0.20 (-7.0 dBc), Sync: 0.0471 (-13.3 dBc), Paging: 0.1882 (-7.3 dBc), 6 Traffic channels: 0.09412 (-10.3 dBc)
- c. Does not include uncertainty due to noise.

| | Specifications | Supplemental Information |
|--|----------------|--------------------------------------|
| Channel Power (1.23 MHz Integration BW) | | Integration BW range 1 kHz to 10 MHz |
| Range at RF Input | 30 to -70 dBm | |
| Absolute power accuracy for in-band signal (Mean channel power at RF Input, plus any external attenuation, excluding mismatch error) | | |
| Cellular Bands | | |
| 30 to -5 dBm 20 to 30 °C | ±0.95 dB | ±0.33 dB, typical |
| 0 to 55 °C | ±1.27 dB | |
| -5 to -25 dBm 20 to 30 °C | ±0.84 dB | ±0.28 dB, typical |
| 0 to 55 °C | ±1.11 dB | |
| -25 to -45 dBm 20 to 30 °C | ±0.87 dB | ±0.29 dB, typical |
| 0 to 55 °C | ±1.12 dB | |
| -45 to -55 dBm 20 to 30 °C | ±0.95 dB | ±0.36 dB, typical |
| 0 to 55 °C | ±1.14 dB | |
| -55 to -70 dBm 20 to 30 °C | ±1.07 dB | ±0.46 dB, typical |
| 0 to 55 °C | ±1.39 dB | |
| PCS Bands | | |
| 30 to -5 dBm 20 to 30 °C | ±0.93 dB | ±0.25 dB, typical |
| 0 to 55 °C | ±1.32 dB | |
| -5 to -25 dBm 20 to 30 °C | ±0.78 dB | ±0.23 dB, typical |
| 0 to 55 °C | ±1.06 dB | |
| -25 to -45 dBm 20 to 30 °C | ±0.77 dB | ±0.25 dB, typical |
| 0 to 55 °C | ±1.05 dB | |

Agilent E4407B Specifications and Characteristics
Options

| | Specifications | Supplemental Information |
|-------------------------------|----------------|--------------------------|
| -45 to -55 dBm 20 to 30 °C | ±0.85 dB | ±0.32 dB, typical |
| 0 to 55 °C | ±1.07 dB | |
| -55 to -70 dBm 20 to 30 °C | ±0.97 dB | ±0.42 dB, typical |
| 0 to 55 °C | ±1.32 dB | |

| | Specifications | Supplemental Information |
|---|----------------------------|--------------------------|
| Channel power relative power accuracy (same channel, different Tx power, input attenuator fixed, RF input range manual). | See Display Scale Fidelity | |

| | Specifications | Supplemental Information |
|------------------------------|----------------|--------------------------|
| Receive Channel Power | | |
| Absolute Power Accuracy | | |
| Cellular bands | | |
| 30 to 0 dBm | ±1.13 dB | ±0.53 dB, typical |
| 0 to -85 dBm | ±1.56 dB | ±0.67 dB, typical |
| PCS bands | | |
| 30 to 0 dBm | ±1.18 dB | ±0.52 dB, typical |
| 0 to -85 dBm | ±1.45 dB | ±0.59 dB, typical |
| Preamp (<i>Option IDS</i>) | | |
| Cellular and PCS bands | | |
| 30 to -80 dBm | ±2.15 dB | ±1.26 dB, typical |
| -80 to -100 dBm | ±2.95 dB | ±1.92 dB, typical |

| | Specifications | Supplemental Information |
|--|----------------|--------------------------|
| Occupied Bandwidth | | |
| Carrier power range | 30 to -45 dBm | |
| Frequency resolution of occupied BW | 1.88 kHz | |
| Frequency accuracy of occupied BW (1.23 MHz channel BW) | | ±15 kHz, characteristic |
| Frequency resolution of delta frequency | 3.75 kHz | |

| | Specifications | Supplemental Information |
|---------------------------------------|----------------|--|
| Frequency accuracy of delta frequency | | $\pm (35 \text{ kHz} + \text{frequency reference error} \times \text{carrier frequency})$, characteristic |

| | Specifications | Supplemental Information |
|---|--------------------|--|
| Code Domain Power (Requires <i>Options 1D5, B7D, and B7E</i> . Measurement interval ≥ 1.25 ms unless otherwise noted.) | | |
| Carrier power range at RF Input (Pilot channel power > -11 dBc) | 30 to -13 dBm | 30 to -65 dBm ^a , characteristic |
| Preamp (<i>Option 1DS</i>) | 30 to -30 dBm | 30 to -82 dBm ^a , characteristic |
| Measurement interval range | 0.5 ms to 26.67 ms | |
| Code domain power | | |
| Display dynamic range | 50 dB | |
| Accuracy (Walsh channel power within 20 dB of total power) | | ± 0.2 dB, typical |
| Displayed resolution | 0.01 dB | |
| Other reported power parameters (dB referenced to total power) | | Average active traffic, maximum inactive traffic, average inactive traffic, pilot, paging, sync channels |
| Carrier frequency error (Measurement interval ≥ 2.5 ms) | | Excludes frequency reference error. |
| Input frequency error range | ± 100 kHz | ± 200 kHz, typical |
| Accuracy | ± 10 Hz | ± 7 Hz, typical |
| Displayed resolution | Four digits | |

Agilent E4407B Specifications and Characteristics
Options

| | Specifications | Supplemental Information |
|---|------------------------|--|
| Estimated Rho | | |
| Range | 0.9 to 1.0 | 0.5 to 1.0 ^b |
| Accuracy (With 9 channels active over the specified range) ^c | | ±0.02, characteristic |
| Displayed resolution | 0.0001 | |
| Pilot time offset | | From even second signal to start of PN sequence |
| Range | -13.33 ms to +13.33 ms | |
| Accuracy | ±150 ns | |
| Displayed resolution | Four digits | |
| Code domain timing | | Pilot to code channel time tolerance |
| Range | ±200 ns | |
| Accuracy (IS-97A nominal power levels) ^d | | ±7 ns, typical |
| Code domain phase | | Pilot to code channel phase tolerance |
| Range | ±200 mrad | |
| Accuracy (IS-97A nominal power levels) ^d | | ±10 mrad, typical |
| Displays | | Power Graph and Metrics, or Power, Timing, and Phase Graphs |

- a. Performance may degrade outside of the specified carrier power range at RF input listed in the specifications column.
b. Performance may degrade outside of the estimated rho range listed in the specifications column.
c. The Active Set Threshold is less than all active channels, but greater than -20 dBc.
d. IS-97A nominal base station test model levels (fraction of carrier power); Pilot: 0.20 (-7.0 dBc), Sync: 0.0471 (-13.3 dBc), Paging: 0.1882 (-7.3 dBc), 6 Traffic channels: 0.09412 (-10.3 dBc)

| | Specifications | Supplemental Information |
|--|---------------------|---|
| Modulation Accuracy (Rho) (Requires <i>Options 1D5, B7D,</i> and <i>B7E</i> . Measurement interval ≥1.25 ms unless otherwise noted.) | | |
| Carrier power range at RF Input | 30 to -28 dBm | 30 to -70 dBm ^a , characteristic |
| Preamp (<i>Option 1D5</i>) | 30 to -45 dBm | 30 to -87 dBm ^a , characteristic |
| Measurement interval range | 0.15 ms to 26.67 ms | |

| | Specifications | Supplemental Information |
|---|------------------------|--|
| Rho (waveform quality) | | |
| Range | 0.9 to 1.0 | 0.5 to 1.0 ^b , characteristic |
| Accuracy | | ±0.0016, typical |
| Displayed resolution | 0.0001 | |
| Carrier frequency error (Measurement interval ≥2.5 ms) | | Excludes frequency reference error |
| Input frequency error range | ±100 kHz | ±200 kHz, typical |
| Accuracy | ±10 Hz | ±7 Hz, typical |
| Displayed resolution | Four digits | |
| Pilot time offset | | From even second signal to start of PN sequence |
| Range | -13.33 ms to +13.33 ms | |
| Accuracy | ±150 ns | |
| Displayed resolution | Four digits | |
| EVM | | |
| Floor | | 3.8%, typical |
| Accuracy ^c | | ±1.1%, typical |
| Displayed Resolution | 0.01% | |
| Carrier feedthrough | | |
| Floor | | -51 dBc, typical |
| Accuracy (Carrier feedthrough ≥ -43 dBc) | | ±2.3 dB, typical |
| Displayed resolution | 0.01 dB | |
| Magnitude error | | |
| Floor | | 3.8%, typical |
| Accuracy ^c | | ±1.1%, typical |
| Displayed resolution | 0.01% | |

Agilent E4407B Specifications and Characteristics
Options

| | Specifications | Supplemental Information |
|-----------------------|----------------|--|
| Phase error | | |
| Accuracy ^c | | ±0.65 degrees, typical |
| Displayed resolution | 0.01 degrees | |
| Displays | | Numeric results or Numeric results and IQ graph |

- a. Performance may degrade outside of the specified carrier power range at RF input listed in the specifications column.
- b. Performance may degrade outside of the rho range listed in the specifications column.
- c. Accuracy does not include the effects of the EVM floor. The measurement variance increases as the result approaches the EVM floor.

| | Specifications | Supplemental Information |
|---------------------------------|--|---|
| Spur Close (In Band) | | |
| Carrier power range at RF Input | 30 to -12 dBm | |
| Dynamic range | | |
| Input power | | |
| 30 to 25 dBm | 55 dB | |
| 25 to 20 dBm | 50 dB | |
| 20 to -12 dBm | 46 dB | |
| Relative accuracy | ±(2.7 dB + 0.01 × (dB from reference level)) | ±(0.3 dB + 0.01 × (dB from reference level)), typical |
| Displayed resolution | 0.01 dB | |

| | Specifications | Supplemental Information |
|---|----------------|--|
| Out-of-Band Spurious^a | | Refer to the Amplitude specifications section in this guide. |

- a. The out-of-band measurement is made with the user-defined tables with 20 frequency ranges each (up to the top 10 spurs per range, 100 spurs maximum). Table parameters include frequency range, RBW, video BW, detector type, and amplitude test limits.

| | Specifications | Supplemental Information |
|---|-----------------|--------------------------|
| Receiver Spurious Emissions | | |
| Spurious emission power range | -20 to -83 dBm | |
| Preamp On (<i>Option 1DS</i>) | -40 to -101 dBm | |
| Absolute spurious emission power accuracy | | |
| -20 to -60 dBm | ±2.1 dB | ±1.1 dB, typical |
| -60 to -83 dBm | ±3.9 dB | ±2.7 dB, typical |
| Preamp On (<i>Option 1DS</i>) | | |
| -40 to -70 dBm | ±2.5 dB | ±1.3 dB, typical |
| -70 to -101 dBm | ±4.0 dB | ±2.6 dB, typical |

| | Specifications | Supplemental Information |
|-------------------------------------|----------------|--------------------------|
| External Correction | | |
| External attenuation, external gain | | |
| Range | -90 to 90 dB | |
| Resolution | 0.01 dB | |

| | Specifications | Supplemental Information |
|---|---------------------|--|
| Trigger | | |
| Trigger source (Actual available choices dependent on measurement) | Free run, external | |
| (<i>Option B7D and B7E</i>) | Add RF Burst, frame | |
| Delay trigger | | |
| Range | 0 to 500 ms | |
| Resolution | 300 ns | |
| RF burst trigger level (<i>Option B7E</i>) | 0 to -25 dBc | |
| Trigger slope (External and RF burst) | Positive/Negative | |
| Frame timing period | 50 ns to 13.6533 s | |
| Frame synchronizing source | External frame sync | Rear panel connector labelled EXT FRAME SYNC (<i>Option B7D</i>) |
| Frame synchronizing slope | Positive/Negative | |

Agilent E4407B Specifications and Characteristics
Options

| | Specifications | Supplemental Information |
|---|-----------------------|---|
| Demod Trigger Source Even second input (Frame trigger only, <i>Option B7D</i> and <i>B7E</i>) PN offset range | 0 to 511 x 64 [chips] | Rear panel connector labelled EXT FRAME SYNC |

GSM Measurement Personality (Option BAH)

Unless otherwise noted, all specifications are with RF input range auto, default GSM measurement settings, and in the in-band frequency range. *Option 1D6* and *Option B72* are required.

| | Specifications | Supplemental Information |
|--------------------------------|--------------------------------------|--------------------------|
| In-Band Frequency Range | | |
| GSM 900, P-GSM bands | 890 to 915 MHz 935 to 960 MHz | |
| GSM 900, E-GSM bands | 880 to 915 MHz 925 to 960 MHz | |
| GSM 900, R-GSM bands | 876 to 915 MHz 921 to 960 MHz | |
| DCS 1800 bands | 1710 to 1785 MHz 1805 to 1880 MHz | |
| PCS 1900 bands | 1850 to 1910 MHz 1930 to 1990 MHz | |

| | Specifications | Supplemental Information |
|--|----------------|--------------------------|
| Transmitter Power (Requires <i>Option B7D</i> or <i>AYX</i>) | | |
| Range at RF Input | 30 to -60 dBm | |
| Absolute power accuracy for in-band signal (Mean channel power at RF Input, plus any external attenuation, excluding mismatch error) | | |
| P-GSM, E-GSM, and R-GSM Bands | | |
| 30 to -20 dBm 20 to 30 °C | ±0.94 dB | ±0.34 dB, typical |
| 0 to 55 °C | ±1.43 dB | |
| -20 to -30 dBm 20 to 30 °C | ±0.80 dB | ±0.28 dB, typical |
| 0 to 55 °C | ±1.10 dB | |

Agilent E4407B Specifications and Characteristics
Options

| | Specifications | Supplemental Information |
|-------------------------------|----------------|--------------------------|
| -30 to -40 dBm 20 to 30 °C | ±0.83 dB | ±0.28 dB, typical |
| 0 to 55 °C | ±1.09 dB | |
| -40 to -50 dBm 20 to 30 °C | ±0.99 dB | ±0.44 dB, typical |
| 0 to 55 °C | ±1.19 dB | |
| -50 to -60 dBm 20 to 30 °C | ±1.13 dB | ±0.57 dB, typical |
| 0 to 55 °C | ±1.31 dB | |
| DCS 1800 and PCS 1900 Bands | | |
| 30 to -20 dBm 20 to 30 °C | ±0.92 dB | ±0.27 dB, typical |
| 0 to 55 °C | ±1.48 dB | |
| -20 to -30 dBm 20 to 30 °C | ±0.74 dB | ±0.26 dB, typical |
| 0 to 55 °C | ±1.09 dB | |
| -30 to -40 dBm 20 to 30 °C | ±0.79 dB | ±0.26 dB, typical |
| 0 to 55 °C | ±1.08 dB | |
| -40 to -50 dBm 20 to 30 °C | ±0.95 dB | ±0.42 dB, typical |
| 0 to 55 °C | ±1.18 dB | |
| -50 to -60 dBm 20 to 30 °C | ±1.09 dB | ±0.55 dB, typical |
| 0 to 55 °C | ±1.30 dB | |

| | Specifications | Supplemental Information |
|---|----------------------------|--------------------------|
| Transmitter Power Relative Power Accuracy (same channel, different Tx power, input attenuator fixed, RF input range manual). | See Display Scale Fidelity | |

| | Specifications | Supplemental Information |
|---|----------------|---|
| Power versus Time (Requires <i>Option B7D</i> or <i>AYX</i>) | | |
| Carrier power range at RF Input | 30 to -23 dBm | 30 to -55 dBm ^a , characteristic |
| Preamplifier On (<i>Option 1DS</i>) | 30 to -40 dBm | 30 to -72 dBm ^a , characteristic |
| Time resolution accuracy | | ±1% of sweep time, characteristic |
| Maximum record length | 8 time slots | |
| Burst to mask uncertainty (Requires <i>Option B7D</i> and <i>B7E</i>) | ±1.0 bit | |

a. Performance may degrade outside of the specified carrier power range at RF input listed in the specifications column.

| | Specifications | Supplemental Information |
|--|--|------------------------------|
| Output RF Spectrum | | |
| Carrier power range at RF Input | | |
| Offsets ≤1800 kHz, 30 kHz RBW | | 30 to -5 dBm, characteristic |
| Offsets >1800 kHz, 100 kHz RBW | | 30 to -4 dBm, characteristic |
| Reference power accuracy | Same as Transmitter Power measurement | |
| Relative accuracy ^a | See Display Scale Fidelity | |
| Spectrum due to modulation displayed dynamic range ^{b,c} | | |
| 100 kHz offset | | 30 dB, characteristic |
| 200 kHz offset | | 60 dB, characteristic |
| 250 kHz offset | | 60 dB, characteristic |
| 400 kHz offset | | 70 dB, characteristic |
| 600 kHz to 1.8 MHz offset | | 79 dB, characteristic |
| 1.8 to 6.0 MHz offset | | 75 dB, characteristic |
| > 6 MHz offset | | 76 dB, characteristic |
| Swept Mode Dynamic Range | | 70 dB, characteristic |

Agilent E4407B Specifications and Characteristics
Options

| | Specifications | Supplemental Information |
|---|----------------|--------------------------|
| Spectrum due to switching transients displayed dynamic range ^{b,c} | | |
| 400 kHz offset | | 62 dB, characteristic |
| 600 kHz offset | | 79 dB, characteristic |
| 1200 kHz offset | | 79 dB, characteristic |
| 1800 kHz offset | | 80 dB, characteristic |
| Swept Mode Dynamic Range | | 70 dB, characteristic |

- a. Does not include uncertainty due to noise.
- b. Displayed dynamic range for specific frequency offsets—applies to CW signal at the specified offset. Dynamic range with a GSM signal may differ.
- c. Using default settings, the RBW filter has a corrected noise BW and impulse BW equivalent to five-pole synchronously tuned filter.

| | Specifications | Supplemental Information |
|---|----------------|---|
| Phase and Frequency Error (Requires <i>Option 1D5, B7D, and B7E</i>) | | |
| Carrier power range at RF Input | 30 to -23 dBm | 30 to -55 dBm ^a , characteristic |
| Preamplifier On (<i>Option 1DS</i>) | 30 to -40 dBm | 30 to -72 dBm ^a , characteristic |
| Phase error | | |
| Range | 0 to 180° | |
| Displayed resolution | 0.01° | |
| Accuracy (Averages ≥10) | | |
| Peak | ±2.1° | ±1.5°, typical |
| RMS | ±1.1° | ±0.6°, typical |
| Frequency error | | Excludes frequency reference error |
| Initial frequency error range | ±100 kHz | |
| Accuracy (Averages ≥10) | ±10 Hz | ±5 Hz, typical |
| I/Q offset range | -10 to -46 dBc | |
| Burst sync time uncertainty | ±0.1 bit | |
| Displays | | Numeric summary |

- a. Performance may degrade outside of the specified carrier power range at RF input listed in the specifications column.

| | Specifications | Supplemental Information |
|-----------------------------------|----------------|---|
| Transmit Band Spurious | | |
| Carrier power range at RF Input | | 30 to -12 dBm, typical |
| Dynamic range | | |
| Upper and lower adjacent segments | | 55 dB, characteristic |
| Upper and lower segments | | 44 dB, characteristic |
| Relative accuracy | | $\pm(0.3 \text{ dB} + 0.01 \times (\text{dB from reference level}))$, characteristic |
| Displayed resolution | 0.01 dB | |

| | Specifications | Supplemental Information |
|---|----------------|--|
| Out-of-Band Spurious^a | | |
| Absolute Spurious Power Accuracy | | Refer to the Amplitude specifications section in this guide. |
| Sensitivity ^b | | |
| RBW | | |
| 1 kHz | | -95 dBm, characteristic |
| 3 kHz | | -90 dBm, characteristic |
| 10 kHz | | -85 dBm, characteristic |
| 30 kHz | | -78 dBm, characteristic |
| 100 kHz | | -71 dBm, characteristic |
| 300 kHz | | -64 dBm, characteristic |
| 1 MHz | | -57 dBm, characteristic |
| 3 MHz | | -50 dBm, characteristic |

a. The out-of-band spurious measurement is made in accordance with the tables defined in the appropriate GSM specification document. The measurement is made over several frequency ranges (up to 10 spurs per range, 100 spurs maximum).

b. With input attenuation of 5 dB. For all other attenuation settings, add (input attenuation - 5) dB.

Agilent E4407B Specifications and Characteristics
Options

| | Specifications | Supplemental Information |
|--|----------------|--------------------------------|
| Receive Band Spurious | | |
| Spurious emission power range ^a | | -20 to -73 dBm, characteristic |
| Preamp On (<i>Option IDS</i>) | | -40 to -91 dBm, characteristic |
| Absolute spurious emission power accuracy | | ±1.5 dB, characteristic |
| -20 to -60 dBm | | ±2.1 dB, characteristic |
| -60 to -73 dBm | | |
| Preamp on (<i>Option IDS</i>) | | ±1.8 dB, characteristic |
| -40 to -70 dBm | | ±3.0 dB, characteristic |
| -70 to -91 dBm | | |

a. Requires bandpass filter centered on receive band, peak detector mode, 0 dB attenuation, 100 kHz RBW. Does not include insertion loss of bandpass filter.

| | Specifications | Supplemental Information |
|--------------------------------|----------------|---|
| Amplitude Range Control | | RF Input Autorange, Manually set Max Total Pwr Manually set Input Atten |

| | Specifications | Supplemental Information |
|--|----------------|--------------------------|
| External Gain/Attenuation Correction | | |
| Base gain, base attenuation, mobile gain, mobile attenuation | | |
| Range | 0 to 81.9 dB | |
| Resolution | 0.01 dB | |

| | Specifications | Supplemental Information |
|--|------------------------|--------------------------|
| Trigger | | |
| Trigger source (Actual available choices dependent on measurement) | Free run, external | |
| (<i>Option B7D and B7E</i>) | Add RF Burst and frame | |

| | Specifications | Supplemental Information |
|---|-------------------------------------|--------------------------|
| RF burst trigger (Option B7E) | | |
| Peak carrier power range ^a | 30 to -25 dBm | 30 to -30 dBm, typical |
| Preamp On (Option 1DS) | 30 to -45 dBm | 30 to -50 dBm, typical |
| Trigger level range | 0 to -25 dB relative to signal peak | |

a. With trigger level set to -6 dB.

| | Specifications | Supplemental Information |
|--|-----------------------|---|
| Burst Sync (Requires Option AYX or B7D) | | |
| Source (Actual available choices dependent on measurement) | RF amplitude, none | |
| (Option B7D and B7E) | Add training sequence | |
| Training sequence code | | GSM defined 0 to 7 Auto (search) or Manual |
| Burst type | | Normal (TCH and CCH) Sync (SCH) Access (RACH) |

General

| | Specifications | Supplemental Information |
|--------------------------|----------------|--------------------------|
| Temperature Range | | |
| Operating | 0 to 55 °C | Floppy disk 10 to 40 °C |
| Storage | -40 to 75 °C | |

| | Specifications | Supplemental Information |
|-------------------------------------|----------------|----------------------------|
| Audible Noise (ISO 7779) | | |
| Sound Pressure at 25 °C | | <40 dBa, (<4.6 Bels power) |

| | Specifications | Supplemental Information |
|-------------------------------|---|--------------------------|
| Military Specification | Has been type tested to the environmental specifications of MIL-PRF-28800F class 3. | |

| | Specifications | Supplemental Information |
|---------------------------------|---|--------------------------|
| EMI Compatibility | Conducted and radiated emission is in compliance with CISPR Pub. 11/1990 Group 1 Class A. | |
| <i>(Option 060)^a</i> | Conducted and radiated emission is in compliance with CISPR Pub. 11/1990 Group 1 Class B ^b . | |

- a. Option 060 is not compatible with Option B7B nor Option 1DP.
- b. Meets Class A performance during dc operation.

| | Specifications | Supplemental Information |
|-------------------------|----------------|---|
| Immunity Testing | | |
| Radiated Immunity | | Testing was done at 3 V/m according to IEC 801-3/1984. When the analyzer tuned frequency is identical to the immunity test signal frequency, there may be signals of up to -60 dBm displayed on the screen. |

| | Specifications | Supplemental Information |
|-------------------------|----------------|---|
| Electrostatic Discharge | | Air discharges of up to 8 kV were applied according to IEC 801-2/1991. Discharges to center pins of any of the connectors may cause damage to the associated circuitry. |

| | Specifications | Supplemental Information |
|----------------------------|--|--------------------------|
| Power Requirements | | |
| ac Operation | | |
| Voltage, frequency | 90 to 132 Vrms, 47 to 440 Hz 195 to 250 Vrms, 47 to 66 Hz | |
| Power Consumption, On | <300 W | |
| Power Consumption, Standby | <5 W | |
| dc Operation | | |
| Voltage | 12 to 20 Vdc | |
| Power Consumption | <200 W | |
| Power Consumption, Standby | <100 mW | |

| | Specifications | Supplemental Information |
|--|----------------|--------------------------|
| Measurement Speed | | |
| Local Measurement and Display Update rate | | |
| Sweep points = 101 | | ≥ 40/s, characteristic |
| Sweep points = 401 | | ≥ 28/s, characteristic |
| Remote Measurement and GPIB Transfer Rate ^{a,b} | | |
| (Option A4H) | | |
| Sweep points = 101 | | ≥ 40/s, characteristic |
| Sweep points = 401 | | ≥ 28/s, characteristic |

Agilent E4407B Specifications and Characteristics
General

| | Specifications | Supplemental Information |
|--|-----------------------|--|
| RF Center Frequency Tune, Measure, and GPIB Transfer Time^{a,c} (Option A4H) Sweep points = 101 Sweep points = 401 | | ≤ 75 ms, characteristic ≤ 90 ms, characteristic |

- a. Display Off (:DISPlay:ENABle OFF), and 32-bit integer data format (:FORMat:DATA INT,32), if *Option AYX* or *A4J* is installed, disable sweep ramp. (:SYSem:PORTs:IFVSweep:ENABle OFF), markers Off, single sweep, measured with IBM compatible PC with 550 MHz Pentium® III running Windows® NT 4.0, one meter GPIB cable, National Instruments PCI-GPIB card and NI-488.2 DLL.
- b. Factory preset, auto align Off, fixed center frequency, RBW = 1 MHz, and span = 20 MHz, fixed center frequency, stop frequency ≤ 3 GHz, average of 100 measurements.
- c. Factory preset, auto align Off, segmented sweep Off, RBW = 1 MHz, span = 20 MHz, stop frequency ≤ 3 GHz, center frequency tune step size = 50 MHz.

| | Specifications | Supplemental Information |
|---|-----------------------|--|
| Data Storage Internal External (10 to 40 °C) 3.5" 1.44 MB, MS-DOS® compatible floppy disk | | 200 Traces or States ^a 200 Traces or States ^a |

- a. When storing traces set to 401 points.

| | Specifications | Supplemental Information |
|--|-----------------------|---|
| Downloadable Program Memory (Option B72) | | 2 MB available memory 10 MB available memory |

| | Specifications | Supplemental Information |
|---|-----------------------|--|
| Demod Tune and Listen Demod (Option BAA or 106) (Option A4J or AYX) | AM Add FM | Internal speaker, front-panel earphone jack and front-panel volume control. An uncalibrated demodulated signal is available on the AUX VIDEO OUT connector at the rear panel. |

| | Specifications | Supplemental Information |
|----------------------------|-----------------------|---|
| <i>(Option 106 or BAA)</i> | | An uncalibrated demodulated signal is available on the EXT VIDEO OUT connector at the rear panel. |

| | Specifications | Supplemental Information |
|---------------------------------|-----------------------|-----------------------------------|
| Weight (without options) | | |
| Net | | 17.1 kg (37.7 lb), characteristic |
| Shipping | | 31.9 kg (70.3 lb), characteristic |

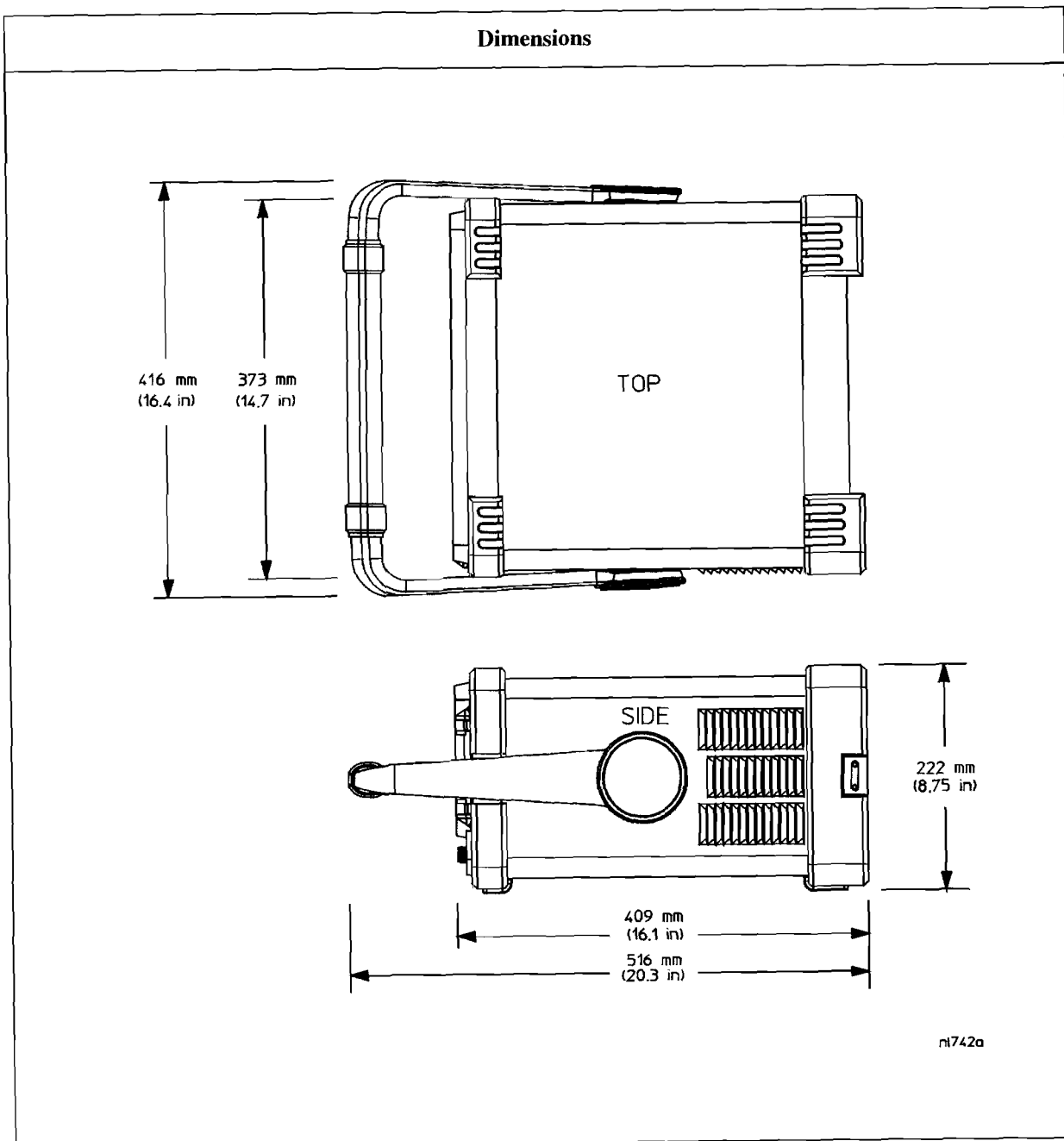

Inputs and Outputs

Front Panel

| | Specifications | Supplemental Information |
|-------------------|----------------|--------------------------|
| INPUT 50 Ω | | |
| Connector | Type-N female | |
| (Option BAB) | APC 3.5 male | |
| Impedance | | 50 Ω, nominal |

| | Specifications | Supplemental Information |
|----------------------------------|----------------|--------------------------|
| RF OUT 50 Ω, (Option 1DN) | | |
| Connector | Type-N female | |
| Impedance | | 50 Ω, nominal |

| | Specifications | Supplemental Information |
|----------------------------------|----------------|--|
| AMPTD REF OUT^a | | Amplitude Reference |
| Connector | BNC female | |
| Impedance | | 50 Ω, nominal |
| Frequency | | 50 MHz |
| Frequency Accuracy | | Frequency reference error ^b |
| 50 Ω Amplitude ^c | | -20 dBm, nominal |

- a. Turn the amplitude reference on/off by pressing the keys: **Input/Output, Amptd Ref Out**.
- b. Frequency reference error = (aging rate × period of time since adjustment + settability + temperature stability).
- c. The internal amplitude reference actual power is stored internally.

| | Specifications | Supplemental Information |
|--------------------|----------------|---|
| PROBE POWER | | |
| Voltage/Current | | +15 Vdc, ±7% at 150 mA max., characteristic |
| | | -12.6 Vdc ±10% at 150 mA max., characteristic |

Agilent E4407B Specifications and Characteristics
Inputs and Outputs

| | Specifications | Supplemental Information |
|---------------------------------|-----------------------|---|
| EXT KEYBOARD^a | | Used for entering screen titles and filenames only. Interface compatible with most IBM-compatible PC keyboards. |
| Connector | 6-pin mini-DIN | |

a. The feature is not implemented in firmware revisions prior to A.04.00.

| | Specifications | Supplemental Information |
|----------------|-----------------------|----------------------------------|
| Speaker | | Front panel knob controls volume |

| | Specifications | Supplemental Information |
|------------------|--|--|
| Headphone | | Front panel knob controls volume |
| Connector | 3.5 mm (1/8 inch) miniature audio jack | |
| Power Output | | 0.2 W into 4 Ω , characteristic |

| | Specifications | Supplemental Information |
|------------------------------|-----------------------|---------------------------------|
| IF INPUT (Option AYZ) | | |
| Connector | SMA female | |
| Impedance | | 50 Ω , nominal |
| Frequency | | 321.4 MHz, characteristic |

| | Specifications | Supplemental Information |
|-------------------------------|-----------------------|--|
| LO OUTPUT (Option AYZ) | | |
| Connector | SMA female | |
| Impedance | | 50 Ω , nominal, must be terminated with 50 Ω |

Rear Panel

| | Specifications | Supplemental Information |
|-----------------------|-----------------------|---------------------------------|
| 10 MHz REF OUT | | |
| Connector | BNC female | |
| Impedance | | 50 Ω , nominal |
| Output Amplitude | | >0 dBm, characteristic |

| | Specifications | Supplemental Information |
|-----------------------|-----------------------|---|
| 10 MHz REF IN | | |
| Connector | BNC female | Note: Analyzer noise sidebands and spurious response performance may be affected by the quality of the external reference used. |
| Impedance | | 50 Ω , nominal |
| Input Amplitude Range | | -15 to +10 dBm, characteristic |
| Frequency | | 10 MHz, nominal |

| | Specifications | Supplemental Information |
|--|--|---------------------------------|
| EXT REF IN <i>(Option B7E)</i> | | |
| Connector | BNC, female | |
| Impedance | | 50 Ω , nominal |
| Input amplitude range | -5 to 10 dBm | |
| Frequency | 1 to 30 MHz, selectable | |
| Frequency lock range | $\pm 5 \times 10^{-6}$ of specified external reference input frequency | |

Agilent E4407B Specifications and Characteristics
Inputs and Outputs

| | Specifications | Supplemental Information |
|--|----------------|------------------------------------|
| 10 MHz OUT <i>(Option B7E)</i> | | |
| Connector | BNC, female | |
| Impedance | | 50 Ω , nominal |
| Frequency | | 10 MHz, nominal |
| Level | | 0 dBm when Option 10 MHz Out is On |

| | Specifications | Supplemental Information |
|--|----------------|---|
| GATE TRIG/EXT TRIG IN | | |
| Connector | BNC female | |
| External Trigger Input | | |
| Trigger Level | | Selectable positive or negative edge initiates sweep in EXT TRIG mode (5 V TTL) |
| Gate Trigger Input <i>(Option 1D6)</i> | | |
| Minimum Pulse Width | | >30 ns (5 V TTL) |

| | Specifications | Supplemental Information |
|---------------------------------|----------------|---|
| GATE/HI SWP OUT | | |
| Connector | BNC female | |
| High Sweep Output | | |
| Level | | High = sweep ^a ; Low = retrace (5 V TTL) |
| Gate Output <i>(Option 1D6)</i> | | |
| Level | | High = gate on; Low = gate off (5 V TTL) |

a. High sweep may be high longer than the indicated sweep times.

| | Specifications | Supplemental Information |
|-------------------|-----------------------------------|--|
| VGA OUTPUT | | |
| Connector | VGA compatible, 15-pin mini D-SUB | VGA (31.5 kHz horizontal, 60 Hz vertical sync rates, non-interlaced) Analog RGB |
| Format | | |
| Resolution | 640 × 480 | |

| | Specifications | Supplemental Information |
|--|-----------------------|--|
| AUX IF OUT <i>(Option A4J or AYZ)</i> | | RBW ≥ 1 kHz |
| Connector | BNC female | 21.4 MHz, nominal –10 dBm (uncorrected), characteristic |
| Frequency | | |
| Amplitude (for signal at reference level and for reference levels – input attenuation + preamp gain of –10 to –70 dBm) | | |
| Impedance | | 50 Ω, nominal |

| | Specifications | Supplemental Information |
|--|-----------------------|--|
| AUX VIDEO OUT <i>(Option A4J or AYZ)</i> | | RBW ≥ 1 kHz |
| Connector | BNC female | 0 to 1 V (uncorrected), characteristic |
| Amplitude Range (into >10 kΩ) | | |

| | Specifications | Supplemental Information |
|--|-----------------------|--|
| HI SWP IN <i>(Option A4J or AYZ)</i> | | |
| Connector | BNC female | Open collector, low resets and holds the sweep (5 V TTL) |
| Input | | |

Agilent E4407B Specifications and Characteristics
Inputs and Outputs

| | Specifications | Supplemental Information |
|--|----------------|---|
| HI SWP OUT (Option A4J or AYX) | | |
| Connector | BNC female | |
| Output | | High = sweep ^a , Low = retrace (5 V TTL) |

a. High sweep may be high longer than the indicated sweep times.

| | Specifications | Supplemental Information |
|---------------------------------------|----------------|---------------------------------|
| SWP OUT (Option A4J or AYX) | | |
| Connector | BNC female | |
| Amplitude | | 0 to +10 V ramp, characteristic |

| | Specifications | Supplemental Information |
|------------------------------|----------------|--|
| PRESEL TUNE OUTPUT | | |
| Connector | BNC female | |
| Load Impedance (dc coupled) | | > 10 k Ω , nominal |
| Range | | 0 to +10 V, characteristic |
| Sensitivity | | |
| Internal Mixing | | 0.33 V/GHz of tuned frequency > 3 GHz, characteristic |
| External Mixing (Option AYZ) | | 1.5 V/GHz of tuned L.O. frequency, characteristic |

| | Specifications | Supplemental Information |
|------------------------------------|------------------------|---|
| GPIB Interface (Option A4H) | | |
| Connector | IEEE-488 bus connector | |
| GPIB Codes | | SH1, AH1, T6, SR1, RL1, PP0, DC1, C1, C2, C3 and C28 |

| | Specifications | Supplemental Information |
|--------------------------------------|------------------|--------------------------|
| Serial Interface (Option IAX) | | |
| Connector | 9-pin D-SUB male | RS-232 |

| | Specifications | Supplemental Information |
|--|-----------------------|---------------------------------|
| Parallel Interface (Option A4H or 1AX) | | Printer port only |
| Connector | 25-pin D-SUB female | |

| | Specifications | Supplemental Information |
|---|-----------------------|--|
| EXT VIDEO IN/TV TRIG OUT^a (Option B7B or BAA) | | EXT VIDEO IN is the Baseband composite video input for TV trigger and picture on screen. TV TRIG OUT is the TV trigger output. |
| Connector | BNC Female (75 Ω) | |
| Impedance | | 75 Ω, nominal |
| (Option BAA without Option B7B) | | Feature not implemented |
| (Option BAA with Option B7B) | | |
| External Video Input Video Amplitude | | 1 V _{p-p} , nominal, characteristic |
| TV Trigger Output | | Positive edge indicates start of selected TV line after sync. pulse |
| Amplitude | | TTL (0 V and 3.4 V with 75 Ω series resistance), characteristic |

a. This connector is labelled EXT VIDEO IN on older spectrum analyzers and EXT VIDEO IN/TV TRIG OUT on newer spectrum analyzers.

| | Specifications | Supplemental Information |
|---|-----------------------|---|
| EXT VIDEO OUT (Option B7B or BAA) | | Baseband video output RBW ≥ 1 kHz |
| Connector | BNC female (75 Ω) | |
| Impedance | | 75 Ω, nominal |
| (Option BAA without Option B7B) | | |
| Amplitude | | 0 to 1 V (uncorrected), characteristic |
| (Option BAA with Option B7B) | | |
| Amplitude | | |
| TV Source: SA | | 0 to 1 V (uncorrected), characteristic |
| TV Source and EXT VIDEO IN | | Same as level at EXT VIDEO IN/TV TRIG OUT, characteristic |

Agilent E4407B Specifications and Characteristics
Inputs and Outputs

| | Specifications | Supplemental Information |
|--|-----------------------|--|
| <i>(Option 106)</i> Connector Impedance Amplitude | BNC female (75 Ω) | 75 Ω, nominal 0 to 1 V (uncorrected), characteristic |

| | Specifications | Supplemental Information |
|--|-----------------------|---------------------------------|
| EXT FRAME SYNC <i>(Option B7D)</i> Connector Level | BNC, female | 5 V TTL |

Regulatory Information

CAUTION This product is designed for use in Installation Category II and Pollution Degree 2 per IEC 1010 and 664 respectively.

NOTE This product has been designed and tested in accordance with IEC Publication 1010, Safety Requirements for Electronic Measuring Apparatus, and has been supplied in a safe condition. The instruction documentation contains information and warnings which must be followed by the user to ensure safe operation and to maintain the product in a safe condition.



The CE mark is a registered trademark of the European Community (if accompanied by a year, it is the year when the design was proven).



The CSA mark is the Canadian Standards Association safety mark.

ISM 1-A

This is a symbol of an Industrial Scientific and Medical Group 1 Class A product. (CISPR 11, Clause 4)

Declaration of Conformity

DECLARATION OF CONFORMITY

According to ISO/IEC Guide 22 and CEN/CENELEC EN 45014

Manufacturer's Name: Agilent Technologies, Inc.

Manufacturer's Address: 1400 Fountaingrove Parkway
Santa Rosa, CA 95403-1799
USA

Declares that the products

Product Name: Spectrum Analyzer

Model Number: E4401B, E4402B, E4403B, E4404B,
E4405B, E4407B, E4408B, E4411B

Product Options: This declaration covers all options of the above products.

Conform to the following product specifications:

EMC: IEC 61326-1:1997+A1:1998 / EN 61326-1:1997+A1:1998

| <u>Standard</u> | <u>Limit</u> |
|--|-------------------------|
| CISPR 11:1990 / EN 55011-1991 | Group 1, Class A |
| IEC 61000-4-2:1995+A1998 / EN 61000-4-2:1995 | 4 kV CD, 8 kV AD |
| IEC 61000-4-3:1995 / EN 61000-4-3:1995 | 3 V/m, 80 - 1000 MHz |
| IEC 61000-4-4:1995 / EN 61000-4-4:1995 | 0.5 kV sig., 1 kV power |
| IEC 61000-4-5:1995 / EN 61000-4-5:1996 | 0.5 kV L-L, 1 kV L-G |
| IEC 61000-4-6:1996 / EN 61000-4-6:1998 | 3 V, 0.15 - 80 MHz |
| IEC 61000-4-11:1994 / EN 61000-4-11:1998 | 1 cycle, 100% |

Safety: IEC 61010-1:1990 + A1:1992 + A2:1995 / EN 61010-1:1993 +A2:1995
CAN/CSA-C22.2 No. 1010.1-92

Supplementary Information:

The products herewith comply with the requirements of the Low Voltage Directive 73/23/EEC and the EMC Directive 89/336/EEC and carry the CE-marking accordingly.



Santa Rosa, CA, USA 17 April 2000

Greg Pfeiffer/Quality Engineering Manager

For further information, please contact your local Agilent Technologies sales office, agent or distributor.