

MT8852B

Bluetooth® Test Set



Operation Manual

MT8852B

***Bluetooth* Test Set**

Anritsu

Safety Symbols

To prevent the risk of personal injury or loss related to equipment malfunction, Anritsu Corporation uses the following safety symbols to indicate safety-related information. Ensure that you clearly understand the meanings of the symbols **BEFORE** using the equipment. Some or all of the following symbols may be used on all Anritsu equipment. In addition, there may be other labels attached to products that are not shown in the diagrams in this manual.

Symbols Used in Manuals



DANGER

This indicates a very dangerous procedure that could result in serious injury or death if not performed properly.



WARNING

This indicates a hazardous procedure that could result in serious injury or death if not performed properly.



CAUTION

This indicates a hazardous procedure or danger that could result in light-to-severe injury, or loss related to equipment malfunction, if proper precautions are not taken.

Safety Symbols Used on Equipment and in Manuals

The following safety symbols are used inside or on the equipment near operation locations to provide information about safety items and operation precautions. Ensure that you clearly understand the meanings of the symbols and take the necessary precautions **BEFORE** using the equipment.



This indicates a prohibited operation. The prohibited operation is indicated symbolically in or near the barred circle.



This indicates a compulsory safety precaution. The required operation is indicated symbolically in or near the circle.



This indicates a warning or caution. The contents are indicated symbolically in or near the triangle.



This indicates a note. The contents are described in the box.



These indicate that the marked part should be recycled.

For Safety

Warning



- ALWAYS refer to the operation manual when working near locations at which the alert mark shown on the left is attached. If the advice in the operation manual is not followed, there is a risk of personal injury or reduced equipment performance. The alert mark shown on the left may also be used with other marks and descriptions to indicate other dangers.
- Overvoltage Category
This equipment complies with overvoltage category II defined in IEC 61010. DO NOT connect this equipment to the power supply of overvoltage category III or IV.

Warning



or



When supplying power to this equipment, connect the accessory 3-pin power cord to a 3-pin grounded power outlet. If a grounded 3-pin outlet is not available, use a conversion adapter and ground the green wire, or connect the frame ground on the rear panel of the equipment to ground. If power is supplied without grounding the equipment, there is a risk of receiving a severe or fatal electric shock.

Warning



Only qualified service personnel with a knowledge of electrical fire and shock hazards should service this equipment. This equipment cannot be repaired by the operator. DO NOT attempt to remove the equipment covers or unit covers or to disassemble internal components. There are high-voltage parts in this equipment presenting a risk of severe injury or fatal electric shock to untrained personnel. In addition, there is a risk of damage to precision components.

Warning



The performance-guarantee seal verifies the integrity of the equipment. To ensure the continued integrity of the equipment, only Anritsu service personnel, or service personnel of an Anritsu sales representative, should break this seal to repair or calibrate the equipment. Be careful not to break the seal by opening the equipment or unit covers. If the performance-guarantee seal is broken by you or a third party, the performance of the equipment cannot be guaranteed.

Caution



Never input a signal of more than the indicated value between the measured terminal and ground. Input of an excessive signal may damage the equipment.

Caution



Electrostatic Discharge (ESD) can damage the highly sensitive circuits in the instrument. ESD is most likely to occur as test devices are being connected to, or disconnected from, the instrument's front and rear panel ports and connectors. You can protect the instrument and test devices by wearing a static-discharge wristband.

Alternatively, you can ground yourself to discharge any static charge by touching the outer chassis of the grounded instrument before touching the instrument's front and rear panel ports and connectors. Avoid touching the test port center conductors unless you are properly grounded and have eliminated the possibility of static discharge.

Repair of damage that is found to be caused by electrostatic discharge is not covered under warranty.

WARRANTY

The Anritsu Corporation will repair this equipment free-of-charge if a malfunction occurs within one year after shipment due to a manufacturing fault. However, software fixes will be made in accordance with the separate Software End-User License Agreement. Moreover, Anritsu Corporation will deem this warranty void when:

- The fault is outside the scope of the warranty conditions separately described in the operation manual.
- The fault is due to mishandling, misuse, or unauthorized modification or repair of the equipment by the customer.
- The fault is due to severe usage clearly exceeding normal usage.
- The fault is due to improper or insufficient maintenance by the customer.
- The fault is due to natural disaster, including fire, wind, flooding, earthquake, lightning strike, or volcanic ash, etc.
- The fault is due to damage caused by acts of destruction, including civil disturbance, riot, or war, etc.
- The fault is due to explosion, accident, or breakdown of any other machinery, facility, or plant, etc.
- The fault is due to use of non-specified peripheral or applied equipment or parts, or consumables, etc.
- The fault is due to use of a non-specified power supply or in a non-specified installation location.
- The fault is due to use in unusual environments(Note).
- The fault is due to activities or ingress of living organisms, such as insects, spiders, fungus, pollen, or seeds.

In addition, this warranty is valid only for the original equipment purchaser. It is not transferable if the equipment is resold. Anritsu Corporation shall assume no liability for injury or financial loss of the customer due to the use of or a failure to be able to use this equipment.

Note: For the purpose of this Warranty, "unusual environments" means use:

- In places of direct sunlight
- In dusty places
- Outdoors
- In liquids, such as water, oil, or organic solvents, and medical fluids, or places where these liquids may adhere
- In salty air or in places where chemically active gases (sulfur dioxide, hydrogen sulfide, chlorine, ammonia, nitrogen dioxide, or hydrogen chloride, etc.) are present
- In places where high-intensity static electric charges or electromagnetic fields are present
- In places where abnormal power voltages (high or low) or instantaneous power failures occur
- In places where condensation occurs
- In the presence of lubricating oil mists
- In places at an altitude of more than 2,000 m
- In the presence of frequent vibration or mechanical shock, such as in cars, ships, or airplanes

Software End-User License Agreement (EULA)

Please read this Software End-User License Agreement (hereafter this EULA) carefully before using (includes executing, copying, registering, etc.) this software (includes programs, databases, scenarios, etc., used to operate, set, etc., Anritsu electronic equipment). By reading this EULA and using this software, you are agreeing to be bound by the terms of its contents and Anritsu Corporation (hereafter Anritsu) hereby grants you the right to use this Software with the Anritsu-specified equipment (hereafter Equipment) for the purposes set out in this EULA.

1. Grant of License and Limitations

- a. Regardless of whether this Software was purchased from or provided free-of-charge by Anritsu, you agree not to rent, lease, lend, or otherwise distribute this Software to third parties and further agree not to disassemble, recompile, reverse engineer, modify, or create derivative works of this Software.
- b. You may make one copy of this Software for backup purposes only.
- c. You are not permitted to reverse engineer this software.
- d. This EULA allows you to install one copy of this Software on one piece of Equipment.

2. Disclaimers

To the extent not prohibited by law, in no event shall Anritsu be liable for personal injury, or any incidental, special, indirect or consequential damages whatsoever, including, without limitation, damages for loss of profits, loss of data, business interruption or any other commercial damages or losses, arising out of or related to your use or inability to use this Software.

3. Limitation of Liability

- a. If a fault (bug) is discovered in this Software, preventing operation as described in the operation manual or specifications whether or not the customer uses this software as described in the manual, Anritsu shall at its own discretion, fix the bug, or exchange the software, or suggest a workaround, free-of-charge. However, notwithstanding the above, the following items shall be excluded from repair and warranty.
 - i. If this Software is deemed to be used for purposes not described in the operation manual or specifications.
 - ii. If this Software is used in conjunction with other non-Anritsu-approved software.
 - iii. Recovery of lost or damaged data.
 - iv. If this Software or the Equipment has been modified, repaired, or otherwise altered without Anritsu's prior approval.
 - v. For any other reasons out of Anritsu's direct control and responsibility, such as but not limited to, natural disasters, software virus infections, etc.
- b. Expenses incurred for transport, hotel, daily allowance, etc., for on-site repairs by Anritsu engineers necessitated by the above faults shall be borne by you.
- c. The warranty period for faults listed in article 3a above covered by this EULA shall be either 6 months from the date of purchase of this Software or 30 days after the date of repair, whichever is longer.

4. Export Restrictions

You may not use or otherwise export or re-export directly or indirectly this Software except as authorized by Japanese and United States law. In particular, this Software may not be exported or re-exported (a) into any Japanese or US embargoed countries or (b) to anyone on the Japanese or US Treasury Department's list of Specially Designated Nationals or the US Department of Commerce Denied Persons List or Entity List. By using this Software, you warrant that you are not located in any such country or on any such list. You also agree that you will not use this Software for any purposes prohibited by Japanese and US law, including, without limitation, the development, design and manufacture or production of missiles or nuclear, chemical or biological weapons of mass destruction.

5. Termination

Anritsu shall deem this EULA terminated if you violate any conditions described herein. This EULA shall also be terminated if the conditions herein cannot be continued for any good reason, such as violation of copyrights, patents, or other laws and ordinances.

6. Reparations

If Anritsu suffers any loss, financial or otherwise, due to your violation of the terms of this EULA, Anritsu shall have the right to seek proportional damages from you.

7. Responsibility after Termination

Upon termination of this EULA in accordance with item 5, you shall cease all use of this Software immediately and shall as directed by Anritsu either destroy or return this Software and any backup copies, full or partial, to Anritsu.

8. Dispute Resolution

If matters of dispute or items not covered by this EULA arise, they shall be resolved by negotiations in good faith between you and Anritsu.

9. Court of Jurisdiction

This EULA shall be interpreted in accordance with Japanese law and any disputes that cannot be resolved by negotiation described in Article 8 shall be settled by the Japanese courts.

CE Conformity Marking

Anritsu affixes the CE conformity marking on the following product(s) in accordance with the Decision 768/2008/EC to indicate that they conform to the EMC, LVD, and RoHS directive of the European Union (EU).



1. Product Model

Model:MT8852B *Bluetooth* Test Set

2. Applied Directive

EMC: Directive 2014/30/EU

LVD: Directive 2014/35/EU

RoHS:Directive 2011/65/EU

3. Applied Standards

- EMC:Emission:EN 61326-1: 2013 (Class A)

Immunity:EN 61326-1: 2013 (Table 2)

Performance Criteria*

IEC 61000-4-2 (ESD)	B
IEC 61000-4-3 (EMF)	A
IEC 61000-4-4 (Burst)	B
IEC 61000-4-5 (Surge)	B
IEC 61000-4-6 (CRF)	A
EC 61000-4-8 (RPFMF)	A
IEC 61000-4-11 (V dip/short)	B,C

*: Performance Criteria

A: The equipment shall continue to operate as intended during and after the test. No degradation of performance or loss of function is allowed below a performance level specified by the manufacturer, when the equipment is used as intended. The performance level may be replaced by a permissible loss of performance. If the minimum performance level or the permissible performance loss is not specified by the manufacturer, either of these may be derived from the product description and documentation and what the user may reasonably expect from the equipment if used as intended.

- B.** The equipment shall continue to operate as intended after the test. No degradation of performance or loss of function is allowed below a performance level specified by the manufacturer, when the equipment is used as intended. The performance level may be replaced by a permissible loss of performance. During the test, degradation of performance is however allowed. No change of actual operating state or stored data is allowed. If the minimum performance level or the permissible performance loss is not specified by the manufacturer, either of these may be derived from the product description and documentation and what the user may reasonably expect from the equipment if used as intended.
- C.** Temporary loss of function is allowed, provided the function is self-recoverable or can be restored by the operation of the controls.

Harmonic current emissions:

EN 61000-3-2: 2006 +A1:2009 A2:2009

(Class A equipment)

No limits apply to this equipment with an active input power under 75 W.

- LVD:EN 61010-1: 2010 (Pollution Degree 2)
- RoHS:EN 50581: 2012 (Category 9)

4. Authorized representative

Name: Murray Coleman
Head of Customer Service EMEA
ANRITSU EMEA Ltd.

Address, city: 200 Capability Green, Luton
Bedfordshire, LU1 3LU

Country: United Kingdom

RCM Conformity Marking

Anritsu affixes the RCM marking onto its conforming products in accordance with the electromagnetic compliance regulations of Australia and New Zealand in order to indicate that these products conform to the EMC regulations of Australia and New Zealand.



1. Product Model

Model: MT8852B *Bluetooth* Test Set

2. Applied Standards

EMC: Emission: EN 61326-1: 2013 (Class A equipment)

Notes On Export Management

This product and its manuals may require an Export License or approval by the government of the product country of origin for re-export from your country.

Before you export this product or any of its manuals, please contact Anritsu Company to confirm whether or not these items are export-controlled.

When disposing of export-controlled items, the products and manuals need to be broken or shredded to such a degree that they cannot be unlawfully used for military purposes.

Crossed-out Wheeled Bin Symbol

Equipment marked with the Crossed-out Wheeled Bin Symbol complies with council directive 2012/19/EU (the “WEEE Directive”) in European Union.

This product uses an LCD backlight lamp that contains mercury. Disposal may be regulated due to environmental considerations. Please contact your local authorities or, within the United States, the Electronics Industries Alliance (www.eiae.org) for disposal or recycling information.



For Products placed on the EU market after August 13, 2005, please contact your local Anritsu representative at the end of the product’s useful life to arrange disposal in accordance with your initial contract at the local law.

产品中有毒有害物质或元素的名称及含量

For Chinese Customers Only YLYB

部件名称	有毒有害物质或元素					
	铅 (Pb)	汞 (Hg)	镉 (Cd)	六价铬 [Cr(VI)]	多溴联苯 (PBB)	多溴二苯醚 (PBDE)
印刷电路板 (PCA)	×	○	×	×	○	○
机壳、支架 (Chassis)	×	○	×	×	○	○
LCD	×	×	×	×	○	○
其他(电缆、风扇、 连接器等) (Appended goods)	×	○	×	×	○	○

○：表示该有毒有害物质在该部件所有均质材料中的含量均在 SJ/T11363-2006 标准规定的限量要求以下。
 ×：表示该有毒有害物质至少在该部件的某一均质材料中的含量超出 SJ/T11363-2006 标准规定的限量要求。

环保使用期限



这个标记是根据 2006/2/28 公布的「电子信息产品污染控制管理办法」以及 SJ/T 11364-2006 「电子信息产品污染控制标识要求」的规定，适用于在中国销售的电子信息产品的环保使用期限。仅限于在遵守该产品的安全规范及使用注意事项的基础上，从生产日起算的该年限内，不会因产品所含有害物质的泄漏或突发性变异，而对环境污染，人身及财产产生深刻地影响。
 注) 电池的环保使用期限是 5 年。生产日期标于产品序号的前四码 (如 S/N 0728XXXX 为 07 年第 28 周生产)。

VxWorks Runtime
License 2000-1189



WindML Target License
2000-1372



NI Device License
3-2000-1486



WindRiver USB Runtime License
2000-1421





Bluetooth SIG Qualification Design (QDL) Certificate

QDL Certificate: This certificate represents the Specifications declared by the Member as having passed the Bluetooth Qualification/Certification Process as specified within the Bluetooth Specifications and as required within the PRD 2.0.

Project Name: **MT8852B Bluetooth Test Set**



This Product Design has passed the Bluetooth Qualification Process

Specification Version: 2.0/2.0+EDR

QDID: B012260

Declared Specifications: Radio, Baseband Conformance, Link Manager, Host Controller Interface

Member Company:	Requirements:	Project Dates:
Anritsu MMD-E	1. Testing	Assessment Date:
Rutherford Close	2. Documentation	January/24/2007
empty	3. Assessment	
Stevenage, Herts SG1 2EF	4. Declaration	Listing Date:
	5. Listing	January/24/2007
Approved by BQE:	6. Marking	
Natividad Caro	7. Compliance to Auditing and Enforcement	

Table of Contents

Chapter 1—General Information

1-1	About this Manual	1-1
	Comments on this Manual	1-1
	Software Versions	1-1
	Notification of Software Release	1-2
	Associated Documentation	1-2
	Conventions	1-2
1-2	Product Description	1-3
	Model Types	1-3
	MT8852B Features	1-4
	Options and Accessories	1-4
1-3	CombiTest	1-5
1-4	BlueSuite Pro3	1-6

Chapter 2—Bluetooth Overview

2-1	Introduction to Bluetooth	2-1
	Bluetooth Overview	2-1
	Bluetooth Special Interests Group	2-1
	Bluetooth Qualification	2-1
	Master and Slave Devices	2-1
	Test Mode	2-2
	RF Test Specification Overview	2-2
2-2	Bluetooth RF Tests	2-3

Chapter 3—Preparation for Use

3-1	Operating Environment	3-1
3-2	Power Requirements	3-1
	AC Line Power	3-1
	Fuses	3-1
	Grounding	3-1
3-3	Unpacking the Product	3-2
	Package Contents	3-2
3-4	Power On Procedure	3-3
3-5	Preparing for Storage	3-3
3-6	Preparing for Shipment	3-3

Chapter 4—Instrument Overview

Table of Contents (Continued)

4-1	Front Panel Layout	4-1
	Keypad	4-2
	Data Entry and Selection	4-2
	Hard Keys	4-4
	Soft Keys	4-4
	Display	4-5
	Test Groups	4-5
	Icons	4-6
	Test Group Availability	4-7
	Component Tests	4-7
4-2	Rear Panel Layout	4-8
4-3	Configurations for Testing	4-9
	Cable Connection	4-9
	Over-air Connection	4-10
	Cable Connection for Low Energy Testing	4-11
	Over-air Connection for Low Energy Testing	4-12

Chapter 5—Test Scripts

5-1	What is a Script?	5-1
5-2	Selecting a Script	5-2
5-3	Configuring a Script	5-3
	Selecting Test Groups	5-3
	Selecting Tests within a Test Group	5-4
	Configuring Test Conditions	5-5
	Configuring Test Limits	5-7
	Configuring Script Specific Settings	5-8
	Configuring Instrument-Wide Script Settings	5-11
	Configuring Display Preferences	5-12
5-4	Naming a Script	5-13
5-5	Locking a Script	5-14
5-6	Unlocking a Script	5-15
5-7	Changing the Password	5-15

Chapter 6—Preparing the EUT for Testing

6-1	Basic Rate and EDR Testing	6-1
	Entering the Bluetooth Address Manually	6-1
	Acquiring the Address by Inquiry	6-2
	Acquiring the Bluetooth Address over an RS232 HCI Interface	6-4
	Acquiring the Bluetooth Address over a USB HCI Interface	6-5
	Acquiring the Bluetooth Address over a USB->RS232 HCI Interface	6-6
6-2	Low Energy Testing	6-7

Chapter 7—Running a Script in Standard Mode

Table of Contents (Continued)

7-1	Standard Mode	7-1
7-2	Supported Tests	7-1
7-3	Testing in Standard Mode	7-2
7-4	Limits	7-3
7-5	Basic Rate Tests	7-4
	Output Power Test	7-4
	Power Control Test	7-6
	Enhanced Power Control Test	7-8
	Results	7-9
	Initial Carrier Test	7-11
	Carrier Drift Test	7-13
	Single Sensitivity Test	7-15
	Multi Slot Sensitivity Test	7-18
	Modulation Index Test	7-21
	Maximum Input Power Test	7-24
7-6	Enhanced Data Rate Tests	7-27
	EDR Relative Tx Power Test	7-27
	EDR Carrier & Modulation Test	7-29
	EDR Differential Phase Test	7-33
	EDR Sensitivity Test	7-35
	EDR BER Floor Test	7-37
	EDR Max Input Test	7-39
7-7	Low Energy Tests	7-41
	Packet Types	7-41
	Output Power Test	7-42
	Carrier & Drift Test	7-44
	Modulation Characteristics Test	7-47
	Sensitivity Test	7-51
	PER Integrity	7-52
	Maximum Input Power Test	7-54

Chapter 8—Running a Script in Single Payload Mode

8-1	Single Payload Mode	8-1
8-2	Supported Tests	8-1
8-3	Testing in Single Payload Mode	8-2
8-4	Test Conditions	8-3
8-5	Results	8-3

Chapter 9—Running a Script in Null Packet Mode

9-1	Null Payload Mode	9-1
9-2	Supported Tests	9-1

Table of Contents (Continued)

9-3	Testing in Null Packet Mode	9-1
	Output Power Test	9-2
	Power Control Test	9-4
	Initial Carrier Test	9-6
	Carrier Drift Test	9-8
	Modulation Index Test	9-10

Chapter 10—Running a Single Test

10-1	Running a Single Test	10-1
------	---------------------------------	------

Chapter 11—Configuration Reference

11-1	Navigation Table	11-2
11-2	Configuring the MT8852B	11-5
	Identity	11-5
	System Interface	11-5
	Display and Sound	11-6
	RX/TX Settings	11-8
	CW Measurements	11-9
	Audio	11-9
	Rear Panel Outputs	11-10
	Signal Generator	11-11
	BLE Pkt Generator	11-11
	AFH Measurements	11-13
11-3	Configuring the Equipment Under Test (EUT)	11-14
	View User Friendly Name	11-14
	View Supported Features	11-14
	EUT RS232 Setup	11-15
	Inquiry/Paging Setup	11-15
	Authentication Setup	11-16
11-4	Configuring Scripts	11-18
	All Scripts Setup	11-18
11-5	Configuring System Features	11-19
	Connection Control	11-19
	EUT Remote Power Control	11-20
	Software Upgrade	11-20
	Feature Control	11-21
11-6	Service Configuration	11-23

Chapter 12—Signal Generator

12-1	Setting Up the Bluetooth Interferer	12-1
------	---	------

Chapter 13—CW Measurements

13-1	Performing Continuous Wave Measurement	13-1
------	--	------

Table of Contents (Continued)

Chapter 14—Audio Measurements

14-1	Testing using Remote Loopback	14-1
14-2	Testing the EUT Transmit Path	14-5
14-3	Testing the EUT Receive Path	14-6
14-4	Putting the EUT into Remote Loopback	14-7
14-5	Using Audio Measurements with AFH	14-7

Chapter 15—Adaptive Frequency Hopping (Option 15)

15-1	Overview of Adaptive Frequency Hopping (AFH)	15-1
15-2	AFH Processing	15-2
15-3	AFH in Bluetooth 1.2	15-3
15-4	MT8852B AFH	15-4
15-5	AFH Test Configuration	15-5
15-6	Assessing AFH	15-5
	Channel Use vs Time	15-5
	FER vs Time	15-7
	Audio Measurements	15-8

Chapter 16—IQ Data Output (Option 17)

16-1	Software Overview	16-1
16-2	EDR Measurements	16-2
	Relative Transmit Power	16-2
	Carrier Frequency Stability	16-2
	Modulation Accuracy	16-2
	Differential Phase Encoding	16-2
	Guard Interval	16-2
16-3	Saving Results	16-3
16-4	Handling Results	16-4
	Generating a Power Burst Profile Graph	16-4
	Generating Graphs from IQ Data	16-4

Chapter 17—Technical Support

17-1	Contacting Support	17-1
17-2	Reporting Problems	17-1
17-3	Anritsu Service Centers	17-1

Appendix A—Specifications

A-1	MT8852B Specification	A-1
-----	-----------------------	-----

Appendix B—Test Conditions

B-1	Test Condition	B-1
-----	----------------	-----

Table of Contents (Continued)

B-2	Glossary	B-2
-----	----------------	-----

Appendix C—Preset Values

C-1	Preset Values	C-1
-----	---------------------	-----

Appendix D—Messages

D-1	Error Messages	D-1
-----	----------------------	-----

D-2	Error Codes	D-8
	Bluetooth Specification 4.0 Devices	D-8
	Internal HCI and Communication List of Error Codes	D-10

Appendix E—Bit and Frame Error Rates

E-1	Bit and Frame Error Rates	E-1
-----	---------------------------------	-----

Appendix F—Terminology Glossary

F-1	Terminology Glossary	F-1
-----	----------------------------	-----

Appendix G—Connector Care and Handling

G-1	Pin Depth Mating Connectors	G-1
-----	-----------------------------------	-----

G-2	Torquing Connectors	G-2
-----	---------------------------	-----

G-3	Mechanical Shock	G-2
-----	------------------------	-----

G-4	Cleaning Connectors	G-3
-----	---------------------------	-----

Appendix H—Low Energy Packet Structure

H-1	Low Energy Packet Structure	H-1
-----	-----------------------------------	-----

Chapter 1 — General Information

1-1 About this Manual

This manual provides information on the following model types:

- MT8852B *Bluetooth* Test Set (with EDR and Audio)
- MT8852B-040 *Bluetooth* Test Set (without EDR or Audio)
- MT8852B-041 *Bluetooth* Test Set (without EDR but with Audio)
- MT8852B-042 *Bluetooth* Test Set (with EDR but without Audio)
- MT8852B-043 *Bluetooth* Test Set for low energy tests only (without BR, EDR, or Audio)

Explanations in this manual apply equally to all of the above model types unless otherwise stated.

Comments on this Manual

Every effort has been made to ensure that this manual is thorough, easy to use, and free from errors. However, to ensure continued improvement, we would welcome your comments on this, or any other Anritsu document.

Please contact us at the address below if you have any comments, good or bad, find any errors or omissions, or have any suggestions on how our documentation could be improved further.

bluetooth.support@anritsu.com

Your comments will be logged and reviewed, and whenever possible, will be reflected in a subsequent release of the document.

Software Versions

This document provides information on the following software versions:

MT8852B:	5.00.001
MT8852B-040:	5.00.001
MT8852B-041:	5.00.001
MT8852B-042:	5.00.001
MT8852B-043:	5.00.001

Some of the features documented in this manual may not be available to users of software releases prior to 5.50.000. Check the version of software by following the procedure below.

1. Turn on the MT8852B and press **Config**.
2. Use the arrow keys to position the cursor at "MT8852B" and press **Sel**.
3. Use the arrow keys to position the cursor at "Identity" and press **Sel**.
4. Check the number that displays to the right of "Version".

Notification of Software Release

The MT8852B software is periodically updated as new features are added to meet market demands. To receive automatic notification of software releases, send a blank e-mail with the subject heading of "MT8852B Software Notification Request" to bluetooth.support@anritsu.com. You will receive an e-mail when new software is available to download.

Associated Documentation

In addition to this manual, the following document is also available on the product CD shipped with the MT8852B *Bluetooth* Test Set.

Table 1-1. Associated Documentation





Part number	Document
13000-00110	MT8852B <i>Bluetooth</i> Test Set Remote Programming Manual

The pdf file listed above can be viewed using Adobe Reader™, a freeware program that can be downloaded from <http://www.adobe.com/>.

Conventions

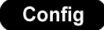
The following conventions have been adopted in this manual.

Table 1-2. Notation Conventions

Item	Convention
MT8852B	Unless otherwise stated, the name "MT8852B" is used generically throughout this manual to refer to all model types of the MT8852B <i>Bluetooth</i> Test Set. Refer to the table on the following page for details of model types.
EUT	The Bluetooth enabled device being tested is referred to as the EUT (Equipment Under Test).
	The five hard keys (Run, Loop/Stop, Script, Config, and Preset) are depicted using an image of the key in question.
	The keys on the numeric keypad are depicted using an image of the key in question.
[Setup]	The names of soft keys appearing on the front panel are enclosed in square brackets.
"Output Power"	Text appearing on the display is enclosed in quotation marks when used in a body of text. Items with quotation marks are selected by pressing  .
 > "MT8852B"	A chevron (>) is used to indicate that the user should select the items or keys in sequential order.
[Log Capture]	The names of software windows and dialogs are enclosed in square brackets.

1-2 Product Description

The MT8852B is a complete *Bluetooth* test solution that supports Basic Rate, Enhanced Data Rate (EDR), and low energy measurements in compliance with the latest *Bluetooth* specification. The MT8852B is the ideal instrument for design proving and production test of *Bluetooth* enabled products.

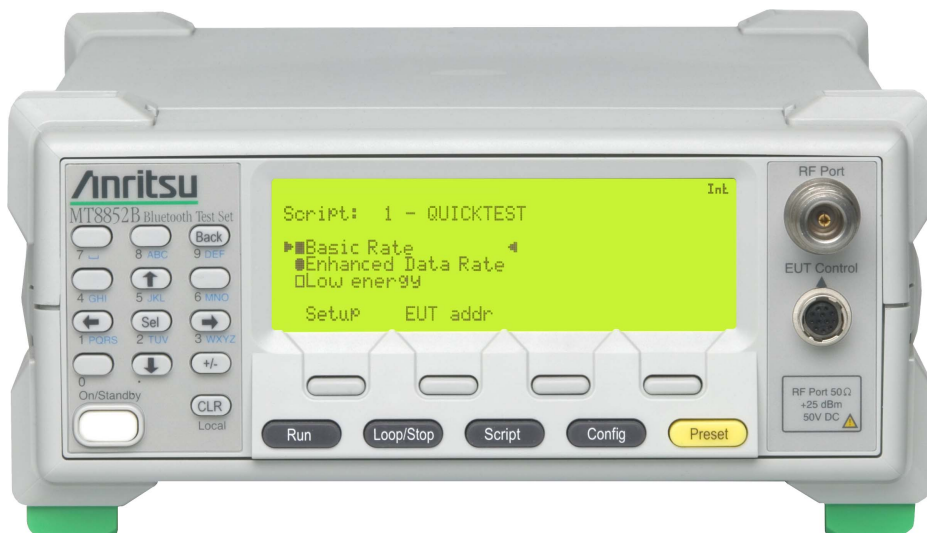

Figure 1-1. MT8852B *Bluetooth* Test Set

Model Types

The table below lists the functionality of each MT8852B model type and explains how the model can be identified by referring to the options sticker on the rear panel (refer to figure 4-8 for details).

Table 1-3. MT8852B Model Types

	Audio Testing	EDR Testing	Rear Panel Notation
MT8852B	Supported	Supported	Option 19, 25
MT8852B-040	Not supported	Not supported	No rear panel notation
MT8852B-041	Supported	Not supported	Option 19
MT8852B-042	Not supported	Supported	Option 25
MT8852B-043	Limited functionality model compatible with <i>Bluetooth</i> low energy measurements only. Basic Rate, audio, and EDR tests are not supported.		Option 29

Note

Options are also available to retrofit audio, EDR, and low energy functionality at a later date if testing requirements change. Refer to table 1-4 for details of available options.

MT8852B Features

- Compliant with the *Bluetooth* 1.2, 2.0, 2.1, 3.0 + HS, 4.0, 4.1, 4.2 and 5.0 core specification releases.
- Configure for testing using antenna interface or cable connection.
- Five model types to meet requirements for Basic Rate, EDR, low energy, and audio testing.
- Three test modes (standard, single payload, and Null packet) to match the level of EUT test mode implementation.
- User-configurable and pre-defined test scripts for one-touch testing.
- Supports three codec air interfaces (μ -law, A-law and CVSD) on up to three SCO audio channels.
- All measurements traceable to National Standards.
- RS232 and GPIB remote control.
- RS232, USB, 2-Wire, USB->RS232 and USB->2-Wire EUT control.
- Audio testing on MT8852B and MT8852B-041 models.
- Adaptive Frequency Hopping (AFH) available with addition of option 15.

Options and Accessories

The table below lists MT8852B options and accessories that are available for purchase.

Table 1-4. Options and Accessories

Number	Item
2400-82	Rack mount kit
MT8852B-015	Adaptive frequency hopping option
MT8852B-017	IQ data output
MT8852B-027	Bluetooth low energy measurements
MT8852B-034	Bluetooth low energy data length extension support
MT8852B-035	Bluetooth low energy 2LE (2 Mbps) support
MT8852B-036	Bluetooth low energy BLR (Long range - LE Coded) support.
MT8852B-334	Retrofit low energy data length extension support
MT8852B-319	Retrofit Audio measurements to MT8852B
MT8852B-325	Retrofit EDR measurements to MT8852B
MT8852B-330	Retrofit Basic Rate measurements to MT8852B
MT8852B-098	Standard calibration to ANSI/NCSL Z540
MT8852B-099	Premium calibration to ANSI/NCSL Z540 (Test report and uncertainty data included)
MX885201B	BlueSuite Pro3 software application
2000-1613-R	Bluetooth antenna and adaptor
D41310	Soft carry bag
13000-00205	MT8852B Operation Manual - printed copy

Table 1-4. Options and Accessories

Number	Item
13000-00110	MT8852B Remote Programming Manual - printed copy

(#1) Only suitable for model types with audio functionality (MT8852B, MT8852B-041).

1-3 CombiTest

The MT8852B can be used in combination with CombiTest, a powerful PC software application used to remotely control Anritsu *Bluetooth* and WLAN test sets for testing of combo modules incorporating both *Bluetooth* and 802.11 radios.

CombiTest is the ideal tool for design-verification or production testing. It allows users to build a test plan in seconds by simply selecting measurement or calibration tasks from the instrument plug-in and configuring them as required.

When ready, the test plan is executed with a single click and a detailed report of results is output automatically.

CombiTest, and the plug-in for the MT8852B, can be downloaded for free from Anritsu's website. Go to <http://www.anritsu.com/en-gb/products-solutions/products/mt8852b.aspx> and click the [Library] tab. Download the CombiTest software package and the MT8852B plug-in. More information on CombiTest can be found in the CombiTest Product Information Sheet available at the address above. Full instructions are provided in the operation manual available from the CombiTest [Help] menu.

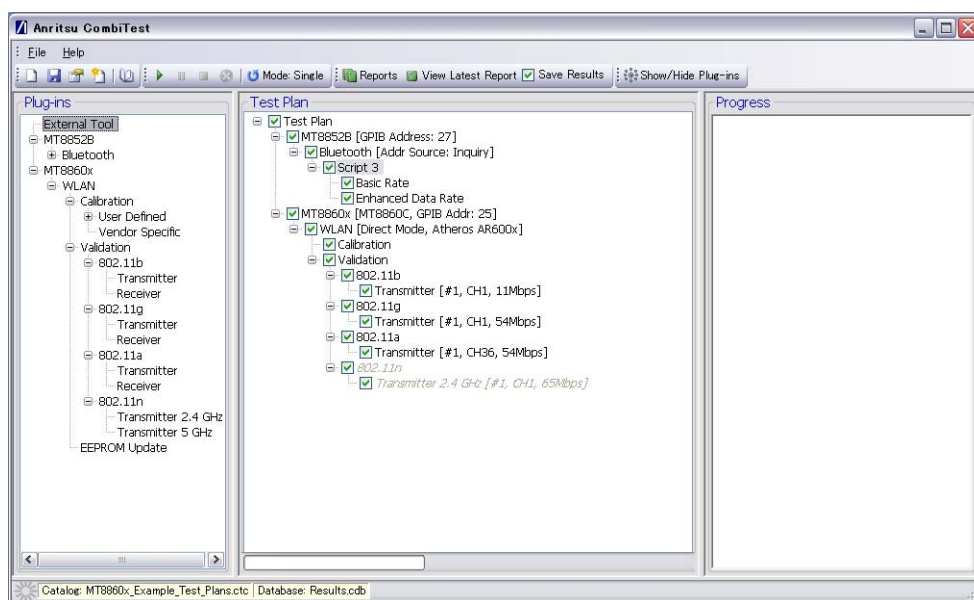

Figure 1-2. CombiTest

1-4 BlueSuite Pro3

The MT8852B can be used in combination with BlueSuite Pro3, a PC software application ideal for detailed analysis of *Bluetooth* packets. The acquired data is presented graphically on the PC, enhancing the analysis and troubleshooting capabilities of the standard MT8852B displays.

Users select the required waveform options (Frequency Deviation, vs Symbol, Power Burst Profile, Vector diagrams, and Constellation diagrams) and simply click run to display detailed colour-coded traces.

BlueSuite Pro3 also facilitates script testing. Users select and configure the required tests and view a detailed test report.

BlueSuite Pro3 is available by ordering option MX885201B as listed earlier in this chapter.

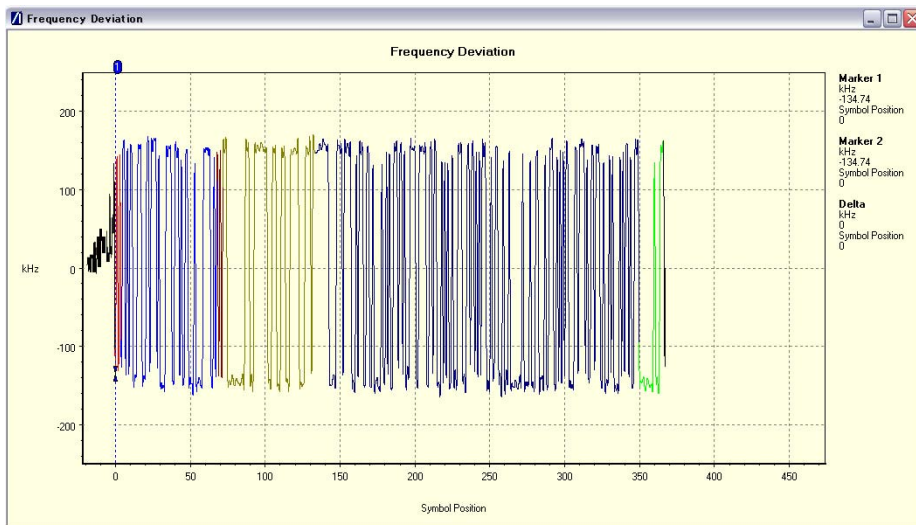

Figure 1-3. BlueSuite Pro3 Frequency Deviation Trace

Chapter 2 — *Bluetooth* Overview

2-1 Introduction to *Bluetooth*

***Bluetooth* Overview**

Bluetooth is an open protocol for short-range wireless and data communication between fixed or mobile devices over distances of up to 10 meters. It operates on the globally unlicensed ISM frequency band at 2.4 GHz. The *Bluetooth* standard is defined by an open specification available publicly and royalty free.

***Bluetooth* Special Interests Group**

The *Bluetooth* Special Interest Group (SIG) oversees the development of the *Bluetooth* standard and the licensing of the *Bluetooth* technologies and trademarks. The SIG is a not-for-profit trade association founded in 1998. Today the SIG has more than 23,000 member companies from a wide cross-section of business sectors.

***Bluetooth* Qualification**

To gain recognition as a *Bluetooth* enabled product, all products (manufacturers) must pass through a nine step qualification process.

1. Join the Special Interest Group (SIG).
2. Enter the Qualification Listing Interface (QLI) on the Bluetooth.org website.
3. Obtain a Qualification Design ID (QD ID).
4. Define supported features; the Test Plan Generator (TPG) automatically generates a suite of required test cases, RF and Protocol.
5. Execute tests as defined above.
6. Log results from tests in the Test Report Declaration (TRD).
7. Complete Declaration of Compliance (DoC) and additional information as required.
8. Complete payment of fees.
9. Product is listed on Qualified Product List (QPL) and End Product List (EPL).

Master and Slave Devices

When *Bluetooth* enabled devices communicate, one device acts as the ‘master’ (issuing clocking and hopping sequence instructions) and the other(s) act as ‘slave’ device. A master device can communicate with up to seven slave device in an ad-hoc network known as a piconet. Data can be transferred between the master device and any other slave device in the piconet but the roles are not fixed and any slave may take on the role of the master device as required.

Test Mode

In addition to normal operation, the *Bluetooth* specification also defines a test mode. Test mode is mandatory for product qualification and included to assist compliance testing of the radio and baseband layers. The tester sends a command that forces the EUT to enter test mode. When enabled, the EUT no longer supports normal operation. Test mode enables a test instrument to put the EUT into the following states:

- Loopback mode
- TX mode
- Payload (PRBS9, 10101010, 11110000)
- Hopping (On or Off)
- Packet length (DH1, DH3, DH5, 2DHx, and 3DHx)

RF Test Specification Overview

The *Bluetooth* specification was initially developed in 1994 based on frequency-hopping spread spectrum technology. In 1998 the specification was formalized by the SIG and has passed through a number of versions since.

- *Bluetooth* 1.0 and 1.0B
The initial specifications used to develop early devices.
- *Bluetooth* 1.1
Added support for non-encrypted channels and also for Received Signal Strength Indicator (RSSI).
- *Bluetooth* 1.2
 - Provided faster discovery and connection.
 - Added Adaptive Frequency Hopping (AFH), to improve resistance to radio frequency interference.
 - Higher transmission speeds.
 - Extended Synchronous Connections (eSCO), which improved voice quality of audio links.
 - Host Controller Interface (HCI) support for three-wire UART.
 - Ratified as IEEE Standard 802.15.1-2005.
 - Introduced Flow Control and Retransmission Modes for L2CAP.
- *Bluetooth* 2.0 (November 2004)
Introduced Enhanced Data Rate (EDR) for data transfer at up to three times previous transmission speeds.
- *Bluetooth* 2.1 (July 2007)
Introduced Extended Inquiry Response (EIR), Encryption pause/resume (EPR), and Secure simple pairing (SSP).
- *Bluetooth* 3.0 + HS (April 2009)
Introduced AMP (Alternate MAC/PHY), the addition of 802.11 as a high speed transport.

- *Bluetooth* 4.0 low energy (December 2009)
In December 2009 the *Bluetooth* SIG introduced *Bluetooth* low energy (previously "Wibree" and "*Bluetooth* Ultra Low Power") as an additional radio option for applications requiring low data throughput and low power consumption.
- *Bluetooth* 4.1 (December 2013)
In December 2013 the *Bluetooth* SIG introduced an update to *Bluetooth* low energy, adding new software features that improve consumer usability.
- *Bluetooth* 4.2 (December 2014)
In December 2014 the *Bluetooth* SIG introduced a further update to *Bluetooth* low energy, adding some key features for IOT including data length extension and privacy updates.
- *Bluetooth* 5 (December 2016)
In December 2016 the *Bluetooth* SIG introduced further enhancements to *Bluetooth* low energy, including 2LE (2 Mbps) to double the transmission speed and BLR (long range) also known as LE Coded. The Stable Modulation Index specification was introduced.

2-2 *Bluetooth* RF Tests

The *Bluetooth* specification defines the following tests:

Basic Rate Tests:

- Transmitter tests:
 - Output power
 - Power density
 - Power control
 - Enhanced power control
 - Output spectrum - frequency range
 - Output spectrum - 20dB bandwidth
 - Output spectrum - ACP
 - Modulation characteristics
 - Initial carrier frequency tolerance
 - Carrier frequency drift
- Receiver tests:
 - Single slot sensitivity
 - Multi slot sensitivity
 - C/I performance
 - Blocking performance
 - Intermodulation performance
 - Maximum input level

Enhanced Data Rate (EDR) Tests:

- Transmitter tests:
 - Relative transmit power
 - Carrier freq. stability and mod. accuracy
 - Differential phase encoding
 - In-band spurious emissions
- Receiver tests:
 - Sensitivity
 - BER floor performance
 - C/I performance
 - Maximum input level

Low Energy Tests:

- Transmitter tests:
 - Output power (normal and extreme operating conditions)
 - In-band emissions (normal and extreme operating conditions)
 - Modulation characteristics
 - Carrier frequency offset and drift (normal and extreme operating conditions)
- Receiver tests:
 - Receiver sensitivity (normal and extreme operating conditions)
 - C/I- and receiver selectivity performance
 - Blocking performance
 - Intermodulation performance
 - Maximum input signal level
 - PER report integrity

Chapter 3 — Preparation for Use

3-1 Operating Environment

The MT8852B is designed to operate within the temperature range of 5 to 40°C with a maximum humidity of 90% at 40°C, non-condensing. Full accuracy is specified at 5 to 35°C.

Although not recommended, operation in temperatures to -20°C is possible. At these temperatures, however, the liquid crystal display may exhibit excessively slow response.

Caution	The instrument is cooled by a fan at the rear that circulates air through the vent holes in the base. The fan and the vent holes should be clear of obstructions at all times regardless of whether the instrument is used as a stand-alone unit or mounted in an equipment rack.
----------------	---

3-2 Power Requirements

The MT8852B is operated from an AC line power. The MT8852B is intended as an Installation (Overvoltage) Category II, Insulation Category I device.

AC Line Power

The MT8852B operates on AC input power of 85-264V, 47-63 Hz, 150 VA maximum. The MT8852B automatically configures itself for the voltage applied. An internal fuse protects the AC line input.

Fuses

The MT8852B is protected on the AC input by an internally mounted fuse. Only qualified service personnel should change this fuse. Replace only with a fuse of the same type and rating: 5 mm x 20 mm, 250V, 2.5A T (T= time lag or slo-blo).

Grounding

The MT8852B must be properly grounded. Failure to ground the instrument could be hazardous to operating personnel. The instrument is supplied with a three-wire power cord.

The instrument is properly grounded when the plug is correctly installed in a grounded receptacle. A grounding terminal is provided on the instrument's rear panel (see figure 4-2).

3-3 Unpacking the Product

1. Inspect the shipping container for signs of damage. If the container is damaged, or if the cushioning material shows signs of stress, notify the carrier and your Anritsu Customer Service Center. Retain the shipping materials for inspection.
2. Check the contents of the shipment against the list of shipped items (detailed below). Notify your local sales representative or Anritsu Customer Service Center if anything is missing or damaged. Retain all damaged items for inspection.
3. Check the instrument for mechanical and electrical operation. If the MT8852B is damaged mechanically, notify your local sales representative or Anritsu Customer Service Center.

Package Contents

The MT8852B is shipped with the following items. Check that all items are present, and contact Anritsu if they cannot be found.

Table 3-1. Package Contents

Item	Quantity
RS 232 HCl control interface lead	1
USB HCl control interface lead	1
RS 232 cable for firmware updates	1
Power cord for destination country	1
Certificate of calibration	1
3.5 mm jack plugs. Audio versions only	3
CD containing:-	
MT8852B Operation Manual	1
MT8852B Remote Programming Manual	1
BlueTest2 Operation Manual	1
BlueTest2 software	1
BlueSuite software (standard version)	1

3-4 Power On Procedure

1. Connect the MT8852B to the power supply.
2. Press the “On/Standby” key.

The MT8852B performs a brief power-on self test (POST) and then displays the Test Groups menu.

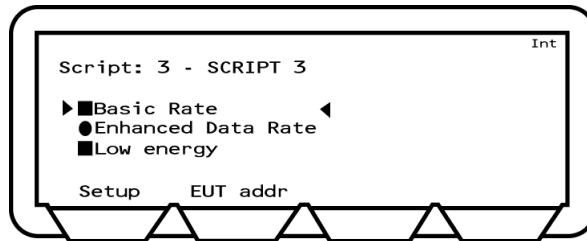

Figure 3-1. Test Groups

3-5 Preparing for Storage

Follow the procedure below if it is necessary to pack and store the MT8852B for an extended period.

1. Clean the MT8852B prior to storage and pack it using moisture-absorbing desiccant crystals.
2. Store the unit in a temperature controlled environment maintained at between 5°C and 40°C, with a maximum humidity of 75% at 40°C, non-condensing.

3-6 Preparing for Shipment

Follow the procedure below if it is necessary to return the MT8852B to Anritsu.

1. Wrap the MT8852B to protect the finish.
2. Position the MT8852B in the original shipping container.

Note If the original shipping container is no longer available, use a strong corrugated cardboard container that is at least 15 cm larger than the MT8852B.

3. Insert cushioning material between the MT8852B and the container. Pack the cushioning material tightly in place while taking care not to put pressure on the RF connector on the front panel.
4. Seal the container carefully; use shipping tape or an industrial stapler.
5. Return the container to the appropriate Anritsu service center. The address of your local service center can be found at <http://www.anritsu.com/Contact.asp>.

Chapter 4 — Instrument Overview

4-1 Front Panel Layout

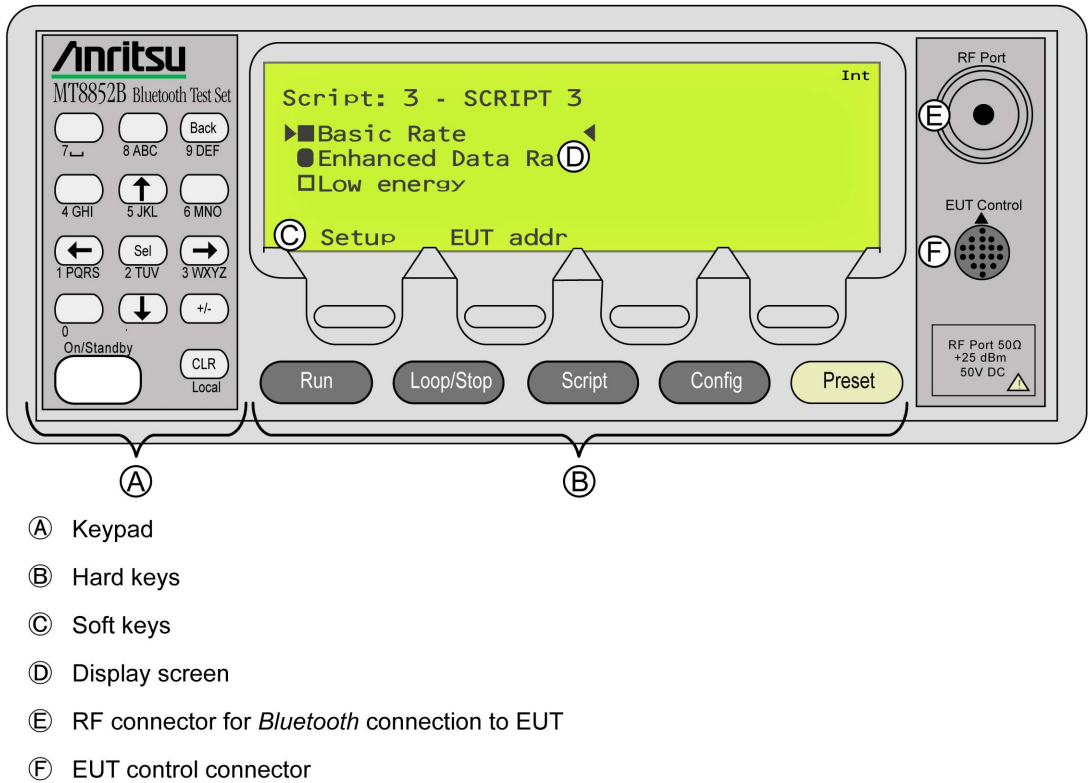

Figure 4-1. MT8852B Front Panel

Keypad

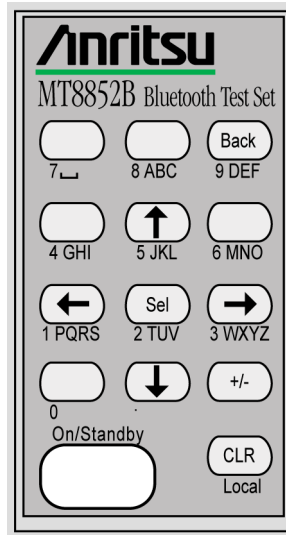

Figure 4-2.

- Back** Returns the display to the previous page or level.
- Sel** Selects or enters the selected function.
- CLR** Clears the last character entered or aborts an operation.
- Moves the cursor in the direction of the arrow.

Data Entry and Selection

The keypad on the front of the MT8852B is used to select and enter data such as test conditions, script names, and *Bluetooth* addresses.

Data Selection

Follow the procedure below to select a single setting from the predefined choices available.

- Use the **↑** or **↓** keys to position the cursor at the required item.
- Press **Sel** to toggle through the settings available. The setting changes each time **Sel** is pressed.

Numeric Entry



As can be seen in figure 4-2, most of the keys on the keypad have text beneath them showing the number and letters that can be entered when the key is pressed. Follow the procedure below to enter a numeric value.

- Use the **↑** or **↓** keys to position the cursor at the required item.
- Press **Sel** to clear the current setting and enable data entry.
- Enter a new value from the keypad. One entry of the number displays on screen with each press of the key.

4. Press the [Enter] soft key.

Numeric/Alphabetic Entry

Follow the procedure below if the selected setting supports alphabetic entry.

1. Use the  or  keys to position the cursor at the required item.
2. Press  to clear the current setting and enable data entry.
3. Enter a new setting from the keypad.

The entry on screen reflects the number of times that the key is pressed. A single key press results in entry of the number appearing beneath the key. Pressing the key twice in succession results in entry of the first of the letters appearing beneath the key.

Further successive key presses result in the entry of the second, third, or fourth letter.

The [Forward] soft key can be used if consecutive entry of two or more identical letters or numbers is required from the same key. Make the first entry in the manner described above and then press [Forward] to move the cursor forward and enable entry again.

4. Press the [Enter] soft key.

Note If a mistake is made, press  to delete the last value entered.

The table below shows the key presses required to enter the address 000091E082A5.

Table 4-1.

Required Entry	Entry Method
0	Press the 0 key followed by the [Forward] soft key.
0	Press the 0 key followed by the [Forward] soft key.
0	Press the 0 key followed by the [Forward] soft key.
0	Press the 0 key.
9	Press the 9 key.
1	Press the 1 key.
E	Press the 9 key three times in succession.
0	Press the 0 key.
8	Press the 8 key.
2	Press the 2 key.
A	Press the 8 key twice in succession.
5	Press the 5 key.

Hard Keys

There are five hard keys on the front panel.

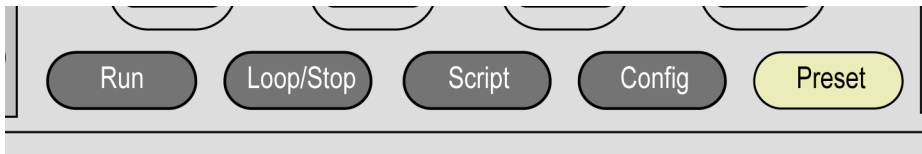

Figure 4-3. Hard Keys

- Run** Executes the selected script or test once.
- Loop/Stop** Executes the selected script or test in a continuous loop. The number of loops is set by the user (**Config** > “All scripts setup” > “Loop count: stop after”).
- Script** Allows the user to set the script, select test groups, and view the component tests for each group.
- Config** Displays the top level configuration menu. Refer to chapter 11 for full details of configuration.
- Preset** Returns the instrument to a predefined state. Refer to Appendix C for details.

Soft Keys

There are four soft key positions on the bottom line of the display.

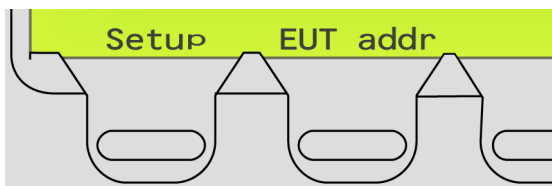

Figure 4-4. Soft Keys

The soft key positions are used only when the soft key function is active; some pages use four soft keys, others use none. The soft keys perform two specific functions:

- They are used to directly access another menu or additional page, e.g., [Setup].
- They are used to initiate an action, e.g., [Enter].

Press the key appearing directly beneath the soft key.

Display

The page shown below displays when the MT8852B is powered on.

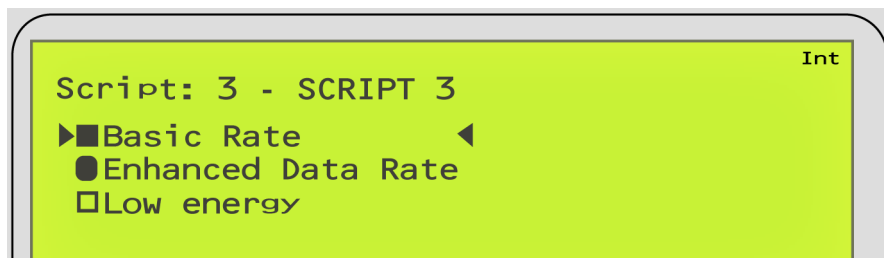

Figure 4-5. Display

Test Groups

There are line items for each of the *Bluetooth* test groups: “Basic Rate”, “Enhanced Data Rate”, and “Low energy”.

Basic Rate

Basic Rate transmissions use Gaussian Frequency Shift Keying (GFSK) modulation with a data rate of 1 Mbit/s. Nine Basic Rate tests are available on the MT8852B.

Enhanced Data Rate (EDR)

EDR transmissions use a combination of GFSK and Phase Shift Keying (PSK) modulation with two variants ($\pi/4$ -DQPSK and 8DPSK) to achieve data rates of 2 and 3 Mbit/s. Six EDR tests are available on the MT8852B.

Low Energy

Formerly known as “Wibree” and “Ultra Low Power”, low energy tests were added to the *Bluetooth* specification in 2009. Low energy is designed specifically for small, predominantly coin-cell battery powered devices for which low power-consumption and low cost are the primary concerns. Low energy test packets are used in all low energy tests, refer to Appendix H for details. Six *Bluetooth* low energy tests are available on the MT8852B.

Icons

Square and circular icons (■ □ ● ○) are used on the MT8852B to indicate which of the three test group are available.

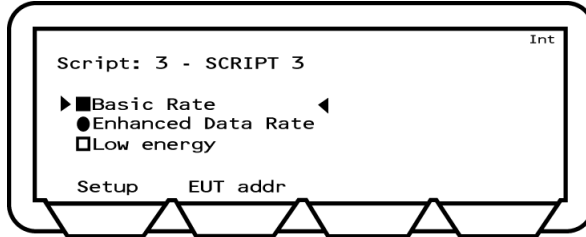

Figure 4-6. Test Group Availability

The same icons are used to indicate which tests are available.

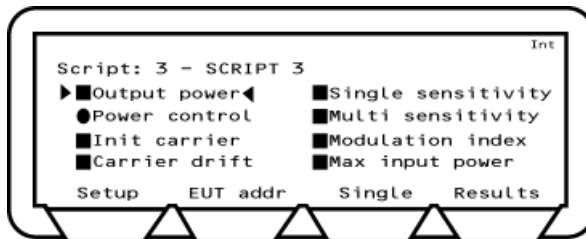

Figure 4-7. Test Availability

The meaning the icons is defined below.

A square indicates that the test group or test is available for use.

- A solid square indicates a selected item.
- A hollow square indicates an item that has not been selected.

A circle indicates that the test group or test is unavailable, or that the MT8852B is unable to determine the availability.

- A solid circle indicates an item that has been selected, if available.
- A hollow circle indicates an item that is unavailable or not selected.

Test Group Availability

The test groups enabled for use on each MT8852B are determined by the model type and the options installed. The model type and option combinations are summarized in the table below.

Table 4-2. Model Types and Test Groups

	Basic Rate	EDR	Low Energy
MT8852B	Available	Available	Not available
MT8852B + option 27	Available	Available	Available
MT8852B-040	Available	Not available	Not available
MT8852B-040 + option 27	Available	Not available	Available
MT8852B-041	Available	Not available	Not available
MT8852B-041 + option 27	Available	Not available	Available
MT8852B-042	Available	Available	Not available
MT8852B-042 + option 27	Available	Available	Available
MT8852B-043	Not available	Not available	Available

Component Tests

The *Bluetooth* tests available within each test group on the MT8852B are listed in the table below.

Table 4-3. Tests Supported in Standard Mode

Basic Rate Tests	Enhanced Data Rate Tests	Low Energy Tests
Output power	Relative Tx power	Output power
Power control	Carrier & mod	Carrier & drift
Enhanced power control	Differential phase	Modulation index
Initial carrier	EDR sensitivity	Sensitivity
Carrier drift	EDR BER floor	PER integrity
Single sensitivity	EDR max input level	Max input power
Multi sensitivity		
Modulation index		
Max input power		

Note

Data Length Extension (DLE) measurements on Bluetooth low energy devices are available with option 34. 2LE (2 Mbps) measurements are available with option 35 and BLR (long range - LE Coded) measurements are available with option 36. MT8852B Options 34, 35 and 36 are available for MT8852B units with Option 27 and MT8852B-043 (Low Energy only) units.

4-2 Rear Panel Layout

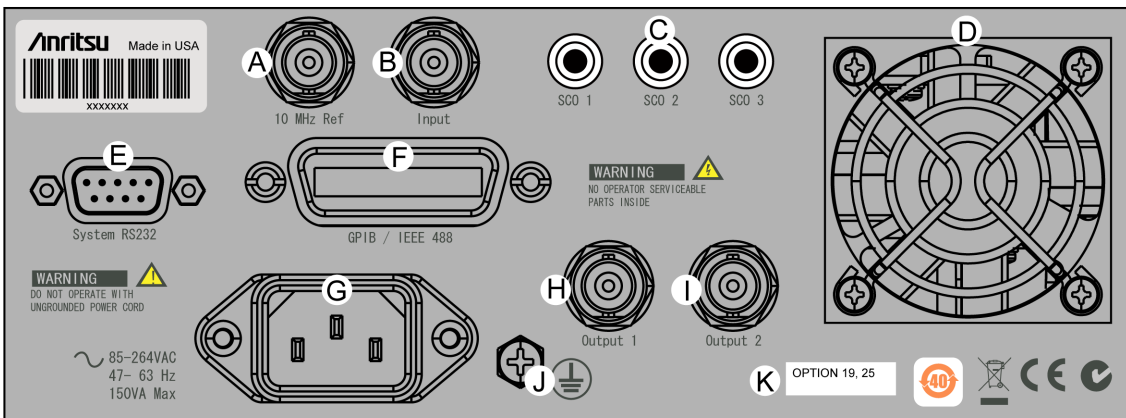

- Ⓐ Input for use of external 10 MHz signal.
- Ⓑ Test input for service test purposes.
- Ⓒ SCO ports. Analogue input and output for audio measurements.
- Ⓓ Cooling fan.
- Ⓔ Serial connector for serial control, software updates, or external HCl control.
- Ⓕ IEEE488 GPIB connector.
- Ⓖ Mains power connector.
- Ⓗ TTL output of TX ON, TX DATA, RX DATA, & CORRELATOR.
- Ⓘ TTL output of RX ON, RX DATA, & CORRELATOR.
- Ⓝ Ground nut. Used if the MT8855B power cord does not have a built-in ground.
- Ⓚ Option label. Label shows options installed at time of manufacture. Retrofit options may not be listed.

Figure 4-8. MT8852B Rear Panel

4-3 Configurations for Testing

The MT8852B can be configured for testing using either a cable or over-air RF connection between the MT8852B and the EUT.

Cable Connection

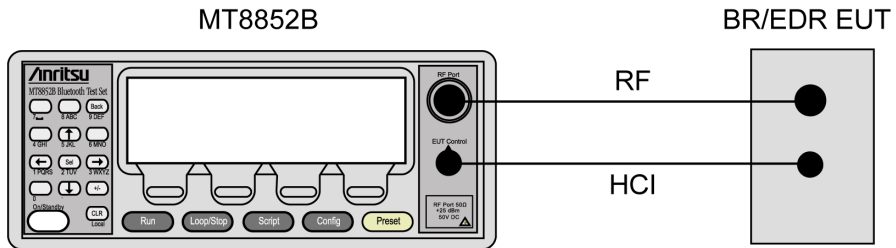

Figure 4-9. Cable Connections

1. Connect an RF cable between the antenna connector on the EUT and the RF Port on the front of the MT8852B.
2. If using the MT8852B to initialise the EUT, connect the RS232 HCI control interface lead (supplied), or USB HCI control interface lead (supplied) from the HCI control connector on the front of the MT8852B to the HCI interface on the EUT.

If not using the MT8852B to initialise the EUT, it must be initialized locally to accept a connection and enter Test Mode.

3. Ensure the MT8852B is connected to the mains power supply.
4. Press the [On/Standby] key on the front panel of the MT8852B.
5. The MT8852B performs a brief power-on self test (POST). After the POST, the instrument displays the Test group menu. If a POST error occurs, information and available options display on the screen.
6. Press **Preset** to restore the default settings. See Appendix C, Preset Values for details.

Over-air Connection

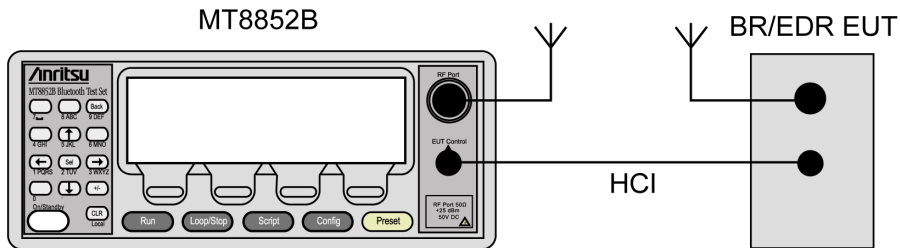

Figure 4-10. Over-Air Connections

1. Connect the *Bluetooth* antenna to the RF port on the front of the MT8852B.
2. If using the MT8852B to initialise the EUT, connect the RS232 HCI control interface lead (supplied), or USB HCI control interface lead (supplied) from the control connector on the front of the MT8852B to the HCI interface on the EUT.

If not using the MT8852B to initialise the EUT, it must be initialized locally to accept a connection and enter Test Mode.

3. Ensure the MT8852B is connected to the mains power supply.
4. Press the [On/Standby] key on the front panel of the MT8852B.
5. The MT8852B performs a brief power-on self test (POST). After the POST, the instrument displays the Test group menu. If a POST error occurs, information and available options will be displayed on the screen.
6. Press **Preset** to restore the default settings. See Appendix C, Preset Values for details.

Cable Connection for Low Energy Testing

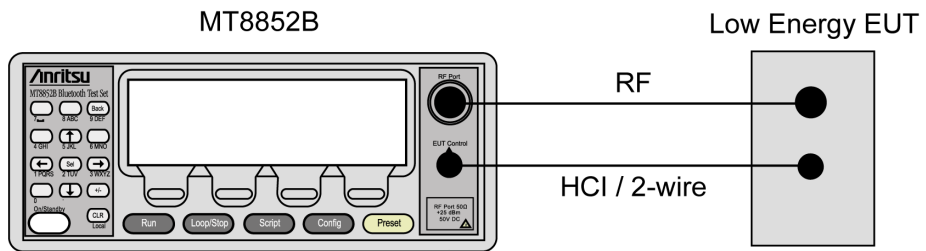

Figure 4-11. Configuration for Low Energy Testing

1. Connect an RF cable between the antenna connector on the DUT and the RF Port on the front of the MT8852B.
2. Connect the supplied RS232 or USB HCI control cable from the EUT Control connector on the front of the MT8852B to the HCI / 2-Wire interface on the EUT.
3. Ensure the MT8852B is connected to the mains power supply.
4. Press the [On/Standby] key on the front panel of the MT8852B.
5. The MT8852B performs a brief power-on self test (POST). After the POST, the instrument displays the Test group menu. If a POST error occurs, information and available options display on the screen.
6. Press **Preset** to restore the default settings. See Appendix C, Preset Values for details.

Over-air Connection for Low Energy Testing

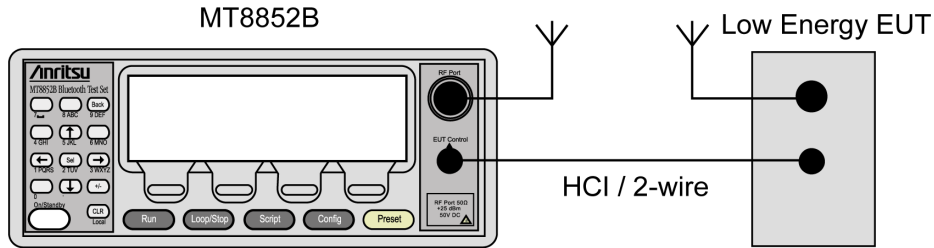
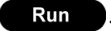

Figure 4-12. Configuration for Low Energy Testing

1. Connect the *Bluetooth* antenna to the RF port on the front of the MT8852B.
2. Connect the supplied RS232 or USB HCI control cable from the EUT control connector on the front of the MT8852B to the HCI / 2-Wire interface on the EUT.
3. Ensure the MT8852B is connected to the mains power supply.
4. Press the [On/Standby] key on the front panel of the MT8852B.
5. The MT8852B performs a brief power-on self test (POST). After the POST, the instrument displays the Test group menu. If a POST error occurs, information and available options display on the screen.
6. Press **Preset** to restore the default settings. See Appendix C, Preset Values for details.

Chapter 5 — Test Scripts

5-1 What is a Script?

A script is a group of tests that have been configured for sequential execution when the user presses .

Scripts can comprise any combination of tests taken from any of the available test groups.

Ten scripts are available on the MT8852B:

Script 1: “QUICKTEST”

Script 1 has been configured to provide the shortest possible test time while still providing sufficient test coverage to ensure good basic RF performance of the EUT. Test time has been minimized by limiting the number of packets that are measured for each test case, and by reducing the number of bits tested during sensitivity measurements.

By default the QUICKTEST script comprises four Basic Rate and four EDR tests. The low energy test group is also available if required and when selected runs four low energy tests. Any of the three test groups within the script can be turned on or off as required, but the tests selected to be run within each group cannot be changed or modified in any way. Script 1 for Basic Rate and EDR testing typically completes in under ten seconds.

Script 2: “FULLTEST”

Script 2 runs every supported test case exactly as defined in the *Bluetooth SIG RF* test specification. This script should be used for full product characterization or long term soak testing. The test cases are performed in full compliance with the RF test specification resulting in longer test times.

By default this script comprises nine Basic Rate and six EDR tests. The low energy test group is also available if required and when selected runs six low energy tests. Any of the three test groups within the script can be turned on or off as required, but the tests selected to be run within each group cannot be changed or modified in any way. Depending on the features supported by the EUT, script 2 typically takes over 2 minutes to complete.

Scripts 3 to 10

Scripts 3 to 10 are unlocked and can be freely configured by the user to match requirements for test coverage and total test time. The default settings for scripts 3 to 10 are the same as for script 2.

5-2 Selecting a Script

1. Power on the MT8852B.
2. Press **Script** to access the test group page shown below.

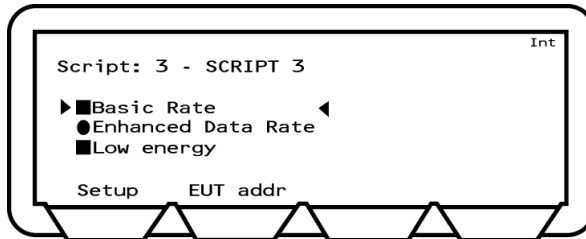

Figure 5-1. Test Groups

3. Press **↑** to move the cursor to the script number.

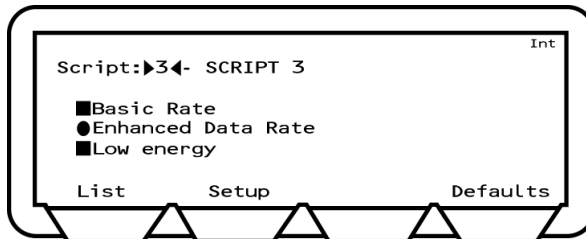

Figure 5-2. Script Number

4. Select the script using either of the methods below:
 - Press **Sel**, enter the required script number from the keypad, and press [Enter].
 - Press [List], use the up and down arrow keys on the keypad to move the cursor to the desired script and press **Sel**.

The selected script number displays at the top of the page.

5-3 Configuring a Script

There are seven steps to configuring a script:

1. Selecting the test groups to be included in the script.
2. Selecting the tests to be run from each of the available test groups.
3. Configuring the test conditions.
4. Configuring the test limits.
5. Configuring the script specific settings.
6. Configuring instrument-wide script settings.
7. Selecting what displays while tests are running.

Note Once configured as required it is not necessary to repeat these steps each time the script is run. Users are however recommended to read through these steps now to familiarize themselves with all settings relating to script configuration.

Selecting Test Groups

The first step in configuring a script is to select which of the available test groups (“Basic Rate”, “Enhanced Data Rate”, and “Low energy”) are to be included. As explained in the previous chapter, the available test groups are determined by the MT8852B model type and the options installed.

1. Select the script as detailed on the previous page.
2. Press  to move the cursor to “Basic Rate”.

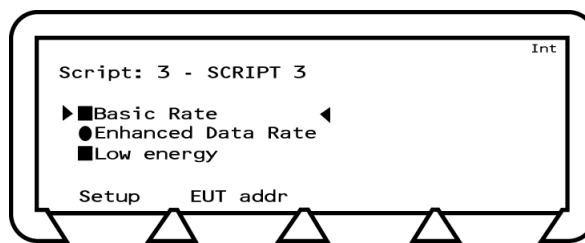





Figure 5-3. Test Groups

3. Use the  key to select or deselect the “Basic Rate” test group as required. A solid square indicates that the group is selected for inclusion in the script; a hollow square indicates that the group is not included in the script.
4. Press  to move the cursor to the next available test group and repeat the procedure as required. As explained earlier in this chapter, the availability of the “Enhanced Data Rate” and “Low energy” test groups depends on the MT8852B model type and the installed options. Unavailable test groups are indicated by a hollow circle that cannot be made solid by pressing the  key.

Selecting Tests within a Test Group

Scripts can be configured to run all or any of the tests within the selected test groups. Tests can be turned on or off as explained below.

1. Use the arrow keys to move the cursor to one of the test groups selected for inclusion in the script.
2. Press the [Setup] soft key to display a page showing the tests within the selected test group.

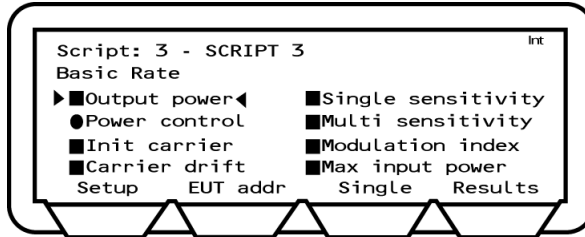

Figure 5-4. Basic Rate Test Group

3. Use the arrow keys to navigate through the tests.
4. Use the **(Sel)** key to select or deselect each test as required.
 - Tests displaying a solid square are run when the script is executed.
 - Tests displaying a solid circle are run when the script is executed if the test is supported by the EUT.
 - Tests displaying a hollow square or hollow circle are not run when the script is executed.
5. Press **(Back)** and repeat steps 1 to 4 for any further test groups selected for inclusion in the script.

Configuring Test Conditions

Each of the tests have a number of test conditions that determine exactly how the test is performed. The test conditions vary depending on the test in question but are typically used to define items such as the hopping mode, the number of packets to be transmitted, and whether the test will be performed in loopback or Tx mode. In all cases, the test conditions include setting items for the EUT Tx and Rx low, medium, and high frequencies.

The test conditions are set by default to match the requirements for the test as defined in the *Bluetooth* specification. Users may wish to perform tests under other conditions and to enable this, scripts 3 to 10 allow the user to change the settings if required.

Note

The default settings for test script 1 (QUICKTEST) are slightly different to those of scripts 2 to 10. Refer to section 5-1 for an explanation of script types.

Refer to Appendix B for an alphabetic listing of all test conditions and their meanings.

1. Use the arrow keys to move the cursor to one of the test groups selected for inclusion in the script.
2. Press the [Setup] soft key to display a page showing the tests within the selected test group.
3. Use the arrow keys to move the cursor to one of the tests selected for inclusion in the script.
4. Press the [Setup] soft key to display the test conditions.

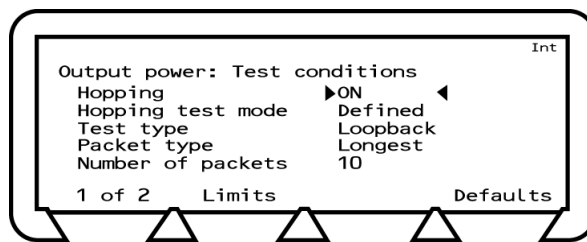
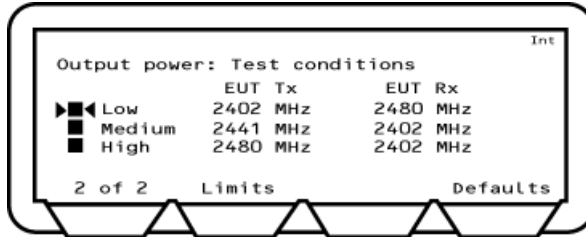

Figure 5-5. Test Conditions

5. Position the cursor on the uppermost test condition.
 - If the test condition requires selection of a parameter, press **(Sel)** to toggle through the settings available. The setting changes each time **(Sel)** is pressed.
 - If the test condition requires entry of a value, press **(Sel)** to clear the current setting and enable data entry. Enter a new value from the keypad and press the [Enter] soft key. If a mistake is made, press **(CLR)** to delete the last value entered, or press the [Defaults] soft key to revert to the original setting as defined in the *Bluetooth* specification.
6. Press **(↓)** to navigate down the list of test conditions, making changes as required by pressing the **(Sel)** key as described above.

7. Press the [1 of x] soft key to display the second page of test conditions and repeat the process described above. The number of pages of test conditions differs depending on the test.
8. Navigate to the last page of test conditions where the EUT Tx and Rx values display for each of the low, medium, and high frequencies at which the test will be conducted. The frequencies match the requirements defined in the *Bluetooth* specification, but can be changed by the user if so required. If the “Test type” test condition is set to “Tx mode”, the Tx and Rx frequencies are set to the same value.



The screenshot shows a screen titled "Output power: Test conditions" with a "Int" label in the top right corner. The screen displays a table of EUT Tx and Rx frequencies for three power levels: Low, Medium, and High. The "Low" level is selected, indicated by a left-pointing arrow. At the bottom of the screen, there are three soft keys: "2 of 2", "Limits", and "Defaults".

	EUT Tx	EUT Rx
▶◀ Low	2402 MHz	2480 MHz
■ Medium	2441 MHz	2402 MHz
■ High	2480 MHz	2402 MHz

Figure 5-6. Tx and Rx Power Settings

Configuring Test Limits

The *Bluetooth* specification defines a number of critical pass criteria for each test; these are reflected on the MT8852B through the use of limit items. Each of the limits is set by default to the value as defined in the specification but the settings can be modified by the user if required.

Follow the procedure below to access a test's limit settings.

1. Use the arrow keys to move the cursor to the test group containing the required test.
2. Press the [Setup] soft key to display a page showing the tests within the selected test group.
3. Use the arrow keys to move the cursor to the required test.
4. Press the [Setup] soft key to display the test conditions.
5. Press the [Limits] soft key to display the Limits page.

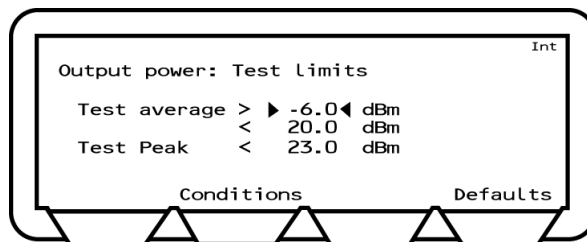

Figure 5-7. Test Limits for the Output Power Test

6. Use the arrow keys to move the cursor to the required position.
7. Press **(Sel)**, enter a new value from the keypad and press the [Enter] soft key.
8. Use the arrow keys to move to any further limits to be changed and enter a new value in the same manner.
9. Press the [Conditions] soft key to return to the test conditions page.

Configuring Script Specific Settings

Each script allows the user to configure a number of settings to determine how the script is run. These settings include items to specify the script mode (standard, single payload, or Null packet), the Tx power level, and the use of a path offset.

1. Select the script to be run as detailed previously.
2. Use the arrow keys to position the cursor at the script number.
3. Press [Setup] to display the script setup page shown below.

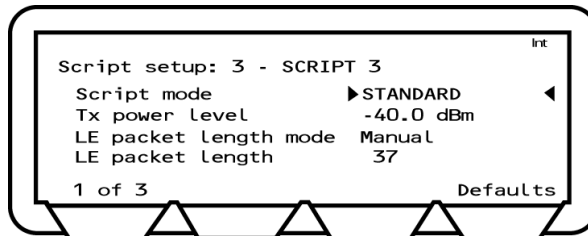

Figure 5-8. Script Setup 1 of 3

4. Specify the script mode.

Press **[Sel]** to toggle the script mode setting between "Standard", "Null Packet", and "Single Payload".

In Standard mode, the MT8852B uses full Test Mode signalling (as defined in chapter 2) and all the defined test controls to test the EUT in the fastest and most efficient way possible. Standard mode is the default setting, although it should be noted that for devices with only a limited implementation of test mode functionality, operation in standard mode may result in the EUT dropping the link or failing to respond to commands from the MT8852B. In this case, select single payload or Null packet operation.

In Single payload mode, the MT8852B uses Test Mode signalling but in a very restricted manner. This is ideal when the EUT does not yet have a full Test Mode implemented, and the repetitive signalling in standard mode could cause it to fail or drop the link.

In Null packet mode the MT8852B does not use Test Mode signalling at all, and makes only a limited subset of tests on packets without payloads. This mode can be used to enable indicative tests to be made on EUTs that have no test mode support. Tests are not performed in accordance with the *Bluetooth* test specification.

Note "Script mode" must be set to "Standard" if low energy measurements are included in the script.

5. Enter the "TX power level" value using the keypad.

TX power level sets the RF power of the MT8852B transmitter. This power level is used for link setup in all tests except EUT receiver sensitivity and maximum input power. The transmission power level can be set to between 0 and -90 dBm.

12. Press the [2 of 3] soft key to move to the third page.

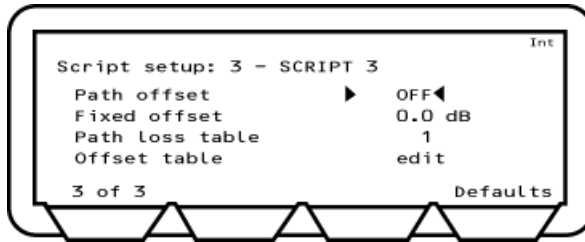

Figure 5-10. Script Setup 3 of 3

13. Set the “Path offset” as required. The path offset feature is used to correct power and sensitivity measurements for the losses in test system cable and connectors. Three settings are available:

OFF: Path offsets are not applied.

FIXED: When path offset is set to FIXED, the specified offset value is applied to every frequency. Enter the offset value from the keypad and press **(Sel)**. Values must be entered in the negative by first pressing **(+/-)**.

TABLE: When path offset is set to TABLE, a different path offset can be applied to each frequency as required. The user can specify use of one of five loss tables for the selected script. Move the cursor to "Path loss table", press **(Sel)** and enter the number (1 to 5) of the loss table that will be used. Press the [Enter] soft key when a selection has been made.

When path offset is set to TABLE, follow the procedure below to create or edit a path offset table.

1. Specify the table number (1 to 5) at the "Path loss table" item as described above.
2. Position the cursor at "edit" directly beneath the table number and press **(Sel)**.
3. Press the [Frequency] soft key, press **(+/-)**, and enter the required frequency.
4. Repeat this process as required for all or any of the 79 frequencies. If fewer than 79 frequencies are entered, the MT8852B interpolates the intermediate values. If a mistake is made, press the [Delete] soft key to delete the selected data line, or press the [Clr Table] soft key to delete the entire table.

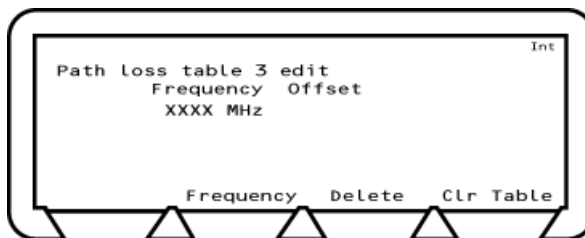

Figure 5-11. Path Loss Table

Configuring Instrument-Wide Script Settings

Configure the parameters that are applied to all scripts. These settings include items that determine if and how tests are looped.

1. Press **Config**.
2. Press the **↓** key twice to select "All Scripts Setup".
3. Press **Sel**.

The Scripts setup page displays.

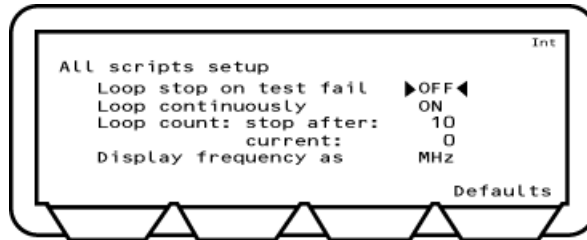

Figure 5-12. All Scripts Setup

4. Use the **Sel** key to select the appropriate setting at "Loop stop on test fail". If set to "ON" the test is run repeatedly until a failure is recorded or the test is stopped.
5. Move the cursor to "Loop continuously" and use the **Sel** key to select the appropriate setting. If set to "ON", the test is run continuously until stopped.
6. Move the cursor to "Loop count", press the **Sel** key, and use the keypad to enter the number of times that the test will be looped. Press the [Enter] soft key after entering the number.
7. Move the cursor to "Display frequency as" and use the **Sel** key to select the appropriate setting. This setting determines whether a channel displays in number format (0 to 78) or in frequency format (MHz).

Configuring Display Preferences

The user can select what displays on the MT8852B while scripts are running.

1. Press **Config**.
2. Press **Sel** to select "MT8852B".
3. Press **↓** twice to move the cursor to "Display/sound" and press **Sel**.
4. Press the [1 of 2] soft key to display the second page of settings.

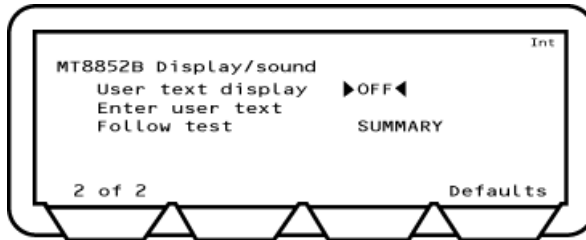

Figure 5-13. Display/Sound

5. Press **↓** to position the cursor At "Follow test" and press **Sel** to toggle through the available settings:
 - SUMMARY:** A summary of the test results displays on the instrument while the script is running.
 - EXTENDED:** The extended results pages display on the instrument while the script is running.
 - OFF:** No test results display on screen while the script is running. The results pages must instead be displayed by the user when the script is complete.

5-4 Naming a Script

Scripts 3 to 10 can be renamed for ease of recognition. Script names can be up to nine characters long using any combination of letters or numbers.

1. Press the **Script** key.
2. Press the **↑** key to position the cursor next to the script number.
3. Press the [List] soft key. The list that displays shows the names of each script and whether they are locked or unlocked.

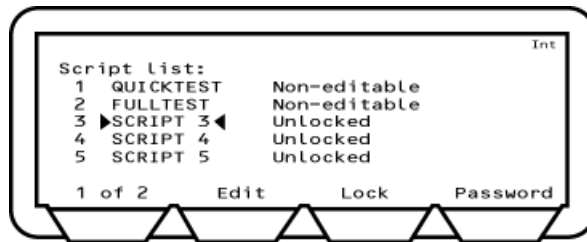

Figure 5-14. Script List

4. Use the **↓** key to move the cursor to the script to be named. Scripts 6 to 10 are accessed by pressing the [1 of 2] soft key.
5. Press the [Edit] soft key and use the keypad to enter a name for the script (as outlined in chapter 4).
6. Press [Enter] when the required name has been entered.

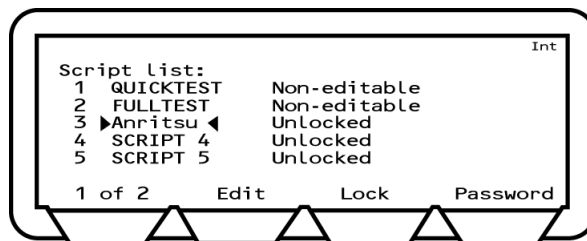

Figure 5-15. Renamed Script

5-5 Locking a Script

Scripts 3 to 10 can be locked (password protected) to prevent unwanted changes.

1. Press the **Script** key.
2. Press the **↑** key to position the cursor next to the script number.
3. Press the [List] soft key.
4. Use the **↓** key to move the cursor to the script to be locked.
5. Press [Passwd], enter the password from the keypad and press [Enter]. The default password is 1234.
6. Press the [Lock] soft key. The status of the script in the list changes to “Locked”.

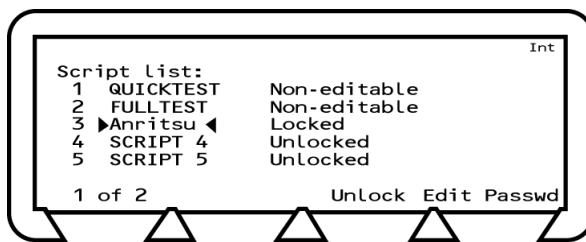

Figure 5-16. Locked Script

5-6 Unlocking a Script

The lock on a script can be removed if changes are required or if protection is no longer necessary.

1. Press the **Script** key.
2. Press the **↑** key to position the cursor next to the script number.
3. Press the [List] soft key.
4. Use the **↓** key to move the cursor to the script to be unlocked.
5. Press [Passwd], enter the password from the keypad and press [Enter]. The default password is 1234.
6. Press the [Unlock] soft key. The status of the script in the list changes to “Unlocked”.

5-7 Changing the Password

The default password (1234) can be changed if required.

1. Press the **Script** key.
2. Press the **↑** key to position the cursor next to the script number.
3. Press the [List] soft key.
4. Press the [Password] soft key, enter the password and press [Enter].
5. Press [Edit Passwd]. Enter the current password and a new four digit password and press [Enter].



Figure 5-17. User Password Edit

Chapter 6 — Preparing the EUT for Testing

6-1 Basic Rate and EDR Testing

For Basic Rate and EDR testing, it is necessary to acquire the *Bluetooth* address and enable EUT test mode and page scanning. The *Bluetooth* address can be acquired using any of the four methods outlined below.

Entering the Bluetooth Address Manually

If the *Bluetooth* address of the EUT is known, it can be entered directly by the operator. When “MANUAL” is selected, the operator is responsible for enabling EUT test mode and turning page scanning on. The procedure for this will vary depending on the EUT.

1. Press **Script** > [EUT addr] to display the page at which the *Bluetooth* connection settings are made.
2. Press **Sel** to toggle the “Source” setting to “MANUAL”.

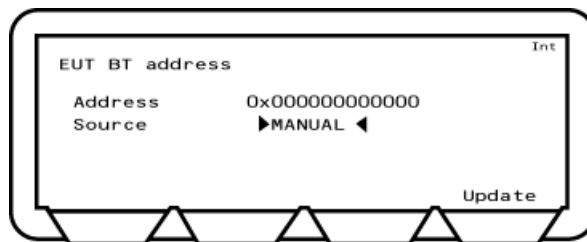

Figure 6-1. Entering the Bluetooth Address Manually

3. Press **↑** or [Update] to move the cursor to “Address” and enter the address from the keypad in the manner outlined in chapter 4.
4. Enable EUT test mode and page scanning.
5. Press [Enter] to complete data entry.

Note

The “MANUAL” setting is not suitable for low energy testing. Refer to section 6.2 for details.

Acquiring the Address by Inquiry

Select “Inquiry” to have the MT8852B perform a search (an inquiry) for all available devices and read the address directly from the EUT through the radio interface. When “INQUIRY” is selected, the operator is responsible for enabling EUT test mode, and turning on page scanning and inquiry scanning. The procedure for this will vary depending on the EUT.

1. Press **Config** > “Equipment Under Test (EUT)” > “Inquiry/paging setup”. Enter the conditions under which the inquiry is performed.

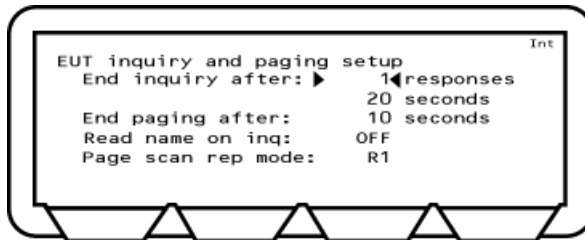

Figure 6-2. EUT Inquiry and Paging Setup

End inquiry after: Specify the number of inquiry responses to be received before the inquiry is finished.

If the number of inquiry responses is set to "1", the MT8852B automatically connects to the first device located. Set the number of responses to 1 if the MT8852B is connected directly to the EUT or there is known to be only one EUT that will respond to an inquiry.

If the response setting is set to a value other than "1" the user must select the required device manually when the inquiry is complete.

End paging after: Enter the number of seconds for which the MT8852B will page the EUT before timing out. A setting at this item may be required to minimize delay for users who know that a connection will not be established by waiting if unsuccessful after a given number of seconds.

Read name on inq: Select whether the EUT name is read-in automatically during the inquiry.

Page scan rep mode: Select either R0, R1, or R2 to match the configuration of the EUT. Connections will take longer than necessary if the settings of the MT8852B and the EUT do not match. The MT8852B cannot read the EUT setting so this must be known to the user.

2. Press **Script** > [EUT addr] to display the page at which the *Bluetooth* connection settings are made.

3. Press **[Sel]** to toggle the “Source” setting to “Inquiry”.

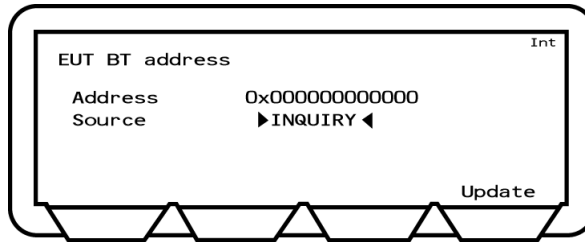

Figure 6-3. Acquiring the Bluetooth Address by Inquiry

4. Enable EUT test mode and set page scanning and inquiry scanning to on.
5. Press the [Update] soft key to commence the inquiry.

Note The “INQUIRY” setting is not suitable for low energy testing. Refer to section 6.2 for details.

Acquiring the Bluetooth Address over an RS232 HCI Interface

Select “RS232” if using an RS232 cable connection between the MT8852B and the EUT. Use of an HCI cable connection, such as RS232, automatically configures the EUT for testing: test mode is enabled and page scanning is turned on.

1. Press **Config** > “Equipment Under Test (EUT)” > “EUT RS232 setup”. Enter the Baud rate used during RS232 communication. The specified baud rate must match the EUT HCI interface setting.

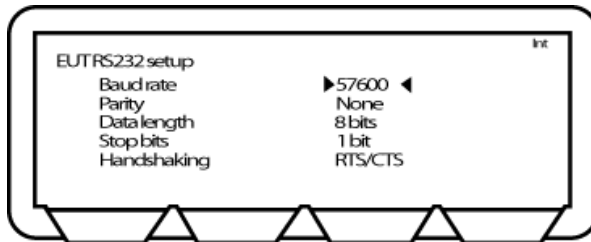

Figure 6-4. EUT RS232 Setup

2. Press **Script** > [EUT addr] to display the page at which the *Bluetooth* connection settings are made.
3. Press **Sel** to toggle the “Source” setting to “RS232”.

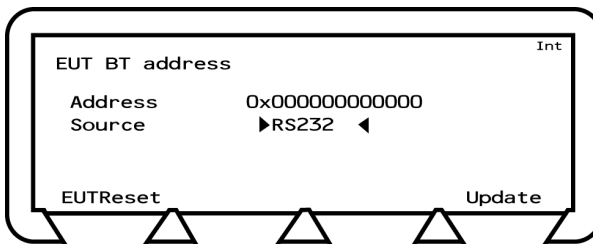

Figure 6-5. Acquiring the Bluetooth Address over RS232

4. Press the [Update] soft key. The *Bluetooth* address is acquired over the RS232 cable and the EUT is configured for testing.

Note The [EUTReset] softkey sends an HCI reset to the EUT via the “EUT Control” port.

Acquiring the Bluetooth Address over a USB HCI Interface

Select “USB” if using an USB cable connection between the MT8852B and the EUT. Use of an HCI cable connection, such as USB, automatically configures the EUT for testing: test mode is enabled and page scanning is turned on.

1. Press **Script** > [EUT addr] to display the page at which the *Bluetooth* connection settings are made.
2. Press **Sel** to toggle the “Source” setting to “USB”.

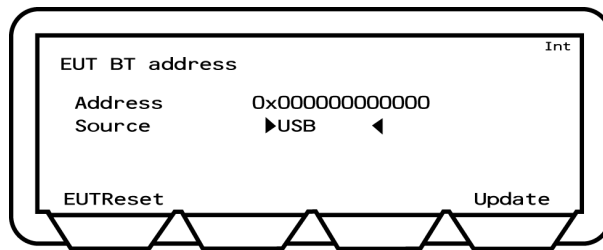

Figure 6-6. Acquiring the Bluetooth Address over USB

3. Press the [Update] soft key. The *Bluetooth* address is acquired over the USB cable and the EUT configured for testing.

Note The [EUTReset] softkey sends an HCI reset to the EUT via the “EUT Control” port.

Acquiring the Bluetooth Address over a USB->RS232 HCI Interface

Select “USB->RS232” if using a USB cable connection between the MT8852B and an EUT containing a USB>RS232 FTDI chip. Use of an HCI cable connection, such as USB>RS232, automatically configures the EUT for testing: test mode is enabled and page scanning is turned on.

1. Press **Config** > “Equipment Under Test (EUT)” > “EUT RS232 setup”. Enter the Baud rate used during RS232 communication. The specified baud rate must match the EUT HCI interface setting.

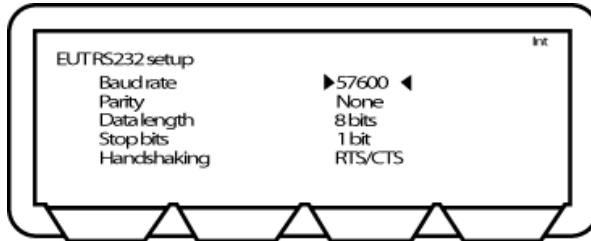

Figure 6-7. EUT RS232 Setup

2. Press **Script** > [EUT addr] to display the page at which the *Bluetooth* connection settings are made.
3. Press **Sel** to toggle the “Source” setting to “USB->RS232”.

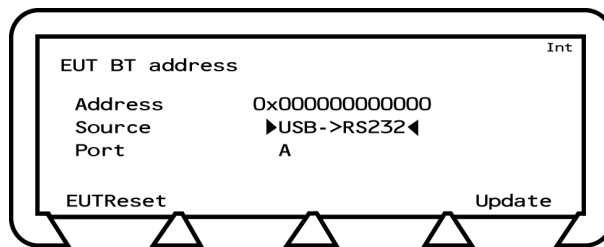

Figure 6-8. Acquiring the Bluetooth Address over RS232

4. Move the cursor to “Port” and, if multiple ports are available, select the port in use.
5. Press the [Update] soft key. The *Bluetooth* address is acquired over the RS232 cable and the EUT is configured for testing.

Note The “USB->RS232” setting can be used with FTDI chips only. Other USB->RS232 chips are not supported.

The “USB->RS232” setting can be used with FTDI > Hub configurations only if the FTDI chip is connected to port 1 on the hub.

The [EUTReset] softkey sends an HCI reset to the EUT via the “EUT Control” port.

6-2 Low Energy Testing

A cable connection (RS232, USB HCI interface, USB->RS232, or 2-Wire interface) to the EUT control interface is required when performing low energy tests. The *Bluetooth* address is not required for low energy testing as no connection is established between the MT8852B and the EUT. The EUT is controlled directly using BLE test mode commands through the control interface.

Select RS232, USB, or USB->RS232 if the low energy device has an HCI interface. Typically this will be a dual mode device supporting basic rate, EDR, and low energy measurements.

Select BLE2WIRE or USB->BLE2WIRE if the EUT does not have an HCI interface and is to be controlled using the special *Bluetooth* 2-Wire interface. Typically this will be a single mode device supporting *Bluetooth* low energy only.

Select “BLE2WIRE” if using a 2-Wire cable between the MT8852B and the *Bluetooth* low energy EUT.

1. Press the **Script** > [EUT addr].
2. Press **Sel** to toggle the “Source” setting to the connection interface in use (“RS232”, “USB”, or “BLE2WIRE”).

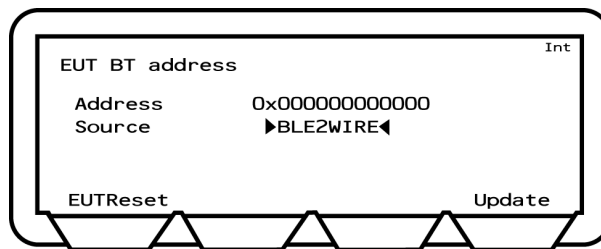

Figure 6-9. BLE2WIRE Selection for Low Energy Testing

3. Press the [Update] soft key to view the address.

Note

The “INQUIRY” and “MANUAL” settings are not suitable for low energy testing. Refer to section 6.1 for details.

The “USB->RS232” and “USB->BLE2WIRE” settings can only be used with FTDI chips. Other USB->RS232 chips are not supported.

The “USB->RS232” and “USB->BLE2WIRE” setting can be used with FTDI > Hub configurations only if the FTDI chip is connected to port 1 on the hub.

The [EUTReset] softkey sends an HCI reset to the EUT via the “EUT Control” port.

Chapter 7 — Running a Script in Standard Mode

7-1 Standard Mode

In Standard mode, the MT8852B uses full test mode signalling and all the defined test controls to test the EUT in the fastest and most efficient way possible.

Note	Standard mode is the default mode setting, although for EUTs with only a limited implementation of test mode functionality, operation in standard mode may result in the EUT dropping the link or failing to respond to commands. In this case, select "Single payload" or "Null packet" mode as outlined in the following chapters.
-------------	--

7-2 Supported Tests

The table below lists the tests that are supported in Standard mode on the MT8852B for each of the *Bluetooth* test types.

Table 7-1. Tests Supported in Standard Mode

Basic Rate Tests (#1)	Enhanced Data Rate Tests (#2)	Low Energy Tests (#3)
Output power	Relative Tx power	Output power
Power control	Carrier & mod	Carrier & drift
Enhanced power control	Differential phase	Modulation index
Initial carrier	EDR sensitivity	Sensitivity
Carrier drift	EDR BER floor	PER Integrity
Single sensitivity	EDR max input level	Max input power
Multi sensitivity		
Modulation index		
Max input power		

(#1) Not available on the MT8852B-043.

(#2) MT8852B and MT8852B-042 only.

(#3) MT8852B-043 and option 27 installed units only. Option 35 is required to support tests on 2LE (Mbps) signals and Option 36 is required to support BLR (long range) signals. In addition, if Option 34 is installed, the test cases can be completed at the maximum packet length supported by the DUT.

7-3 Testing in Standard Mode

1. Configure the script as outlined in chapter 5, ensuring that “Script mode” is set to “STARNDARD”. Refer to chapter 5, “Configuring Script Specific Settings”.
2. Select the EUT address “Source” settings to match the configuration in use. Refer to chapter 6.

Note A cable connection with the EUT (RS232, 2-Wire, USB->RS232 or USB->2-Wire) is required if low energy scripts are included in the script to be run.

3. Press **Script** to access the test group page.
4. Press **↑** to move the cursor to the script number.
5. Select the script to be run using either of the methods below:
 - Press **Sel**, enter the required script number from the keypad, and press [Enter].
 - Press [List], use the up and down arrow keys on the keypad to move the cursor to the desired script and press **Sel**.
6. Press **Run** to run the script once, or press **Loop/Stop** to run the test script in accordance with the instrument-wide script parameters outlined in chapter 5.
7. If required, press the [Abort] soft key to terminate the script immediately. Press **Loop/Stop** again to stop at the end of a script.
8. Press the [Results] soft key to view the test results.
9. The results given on the initial page are a summary of the tests conducted. For more detailed results press the "Extended" soft key. An extended page displays for each of the test combinations. For example, if a test is performed at high, medium, and low frequencies, with hopping on and off, there may be up to six extended pages, and the user can page through these in the normal manner by pressing the "1 of 6" soft key.

Note The "Follow Test" setting (**Config** > MT8852B > Display/sound > [1 of 2]) allows the user to select whether to display the “Extended” or “Summary” results pages while the tests are being performed. If "Follow test" is set to "OFF", the results pages must be displayed by the user when the script is complete.

7-4 Limits

Each of the tests that can be performed on the MT8852B is defined in the *Bluetooth* specification. For each test, the specification defines a number of critical pass criteria that are reflected on the MT8852B through the use of a limit item. Each test has between one and four limit settings, some of which are used for a number of different tests while others are used solely on one test.

Each of the limits is set by default to the value as defined in the *Bluetooth* specification but any of the limit settings can be changed at the user's discretion.

Follow the procedure below to access the limit settings.

1. Use the arrow keys to move the cursor to the test group containing the required test.
2. Press the [Setup] soft key to display a page showing the tests within the selected test group.
3. Use the arrow keys to move the cursor to the required test.
4. Press the [Setup] soft key to display the test conditions.

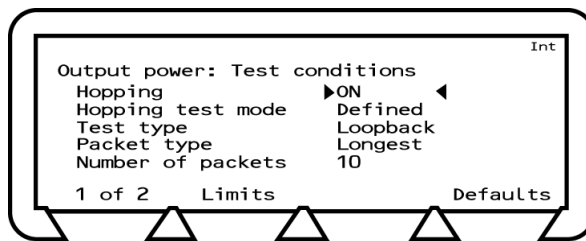

Figure 7-1. Output Power Test Conditions

5. Press the [Limits] soft key to display the Limits page for the test in question.

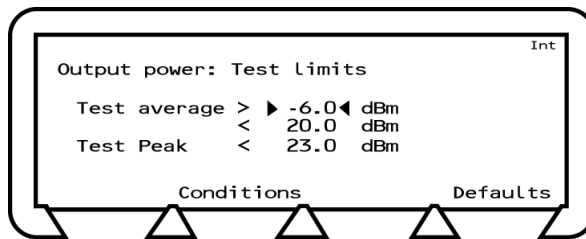

Figure 7-2. Output Power Test Results

6. Use the arrow keys to move the cursor to the required position.
7. Press (Sel), enter a new value from the keypad and press the [Enter] soft key.
8. Use the arrow keys to move to any further limits to be changed and enter a new value in the same manner.
9. Press the [Conditions] soft key to return to the test conditions page.

7-5 Basic Rate Tests (Not available on MT8852B-043)

Output Power Test

If “Test type” is set to “Loopback”, the MT8852B transmits a pseudo random data payload (PRBS9) of the longest supported type (DH5, DH3 or DH1), to the EUT. The EUT loops the data back to the MT8852B at its maximum output power and the MT8852B measures the received power.

If “Test type” is set to “Tx mode”, the MT8852B sends a Poll packet to the EUT which responds with a packet as defined in the “Packet type” field.

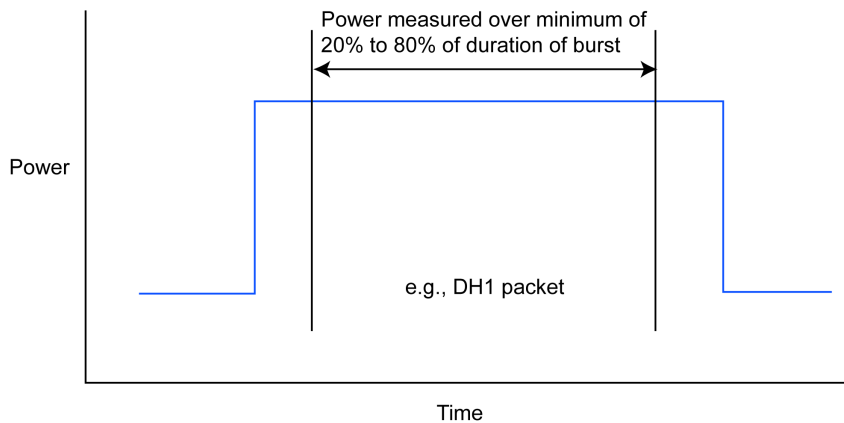

Figure 7-3. Output Power Test

The table below details the test conditions and the associated default settings. Permitted variations from the default setting are detailed in the “User Range” column.

Table 7-2. Output Power Test Conditions

Parameter	Default value	User Range
Hopping	ON	ON, OFF&ON, OFF
Hopping test mode	Defined	Defined, All, Any
Test type	Loopback	Loopback, Tx mode
Packet type	Longest	Longest, DH1, DH3, DH5
Number of packets	10	1 to 10,000

Results

1. Position the cursor at "Output power" in the Script menu.
2. Press the [Results] soft key.

The Output power results page displays.

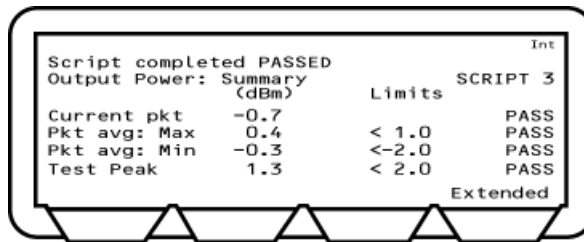

Figure 7-4. Output Power Results

- Current pkt:** Displays the average power of the last packet measured by the MT8852B. The MT8852B identifies the position of the first bit (p0) in the packet and measures the power in each individual bit. Packet avg is the average power of all the measured bits.
- Pkt avg; Max:** Displays the highest power measured of all of the Packet avg measurements during the test.
- Pkt avg; Min:** Displays the lowest power measured of all of the Packet avg measurements during the test.
- Test peak:** This is the power of the single bit in the packet that has the greatest power. The value displayed is the largest peak power measured for all packets in the test.

- Press the [Extended] soft key to display more detailed test results. Unlike the summary page shown above, the extended pages are specific to each of the test scenarios. If a test is performed at high, medium, and low frequencies, with hopping both on and off, there would be six extended pages. An example of the first extended page for the output power test is shown below.

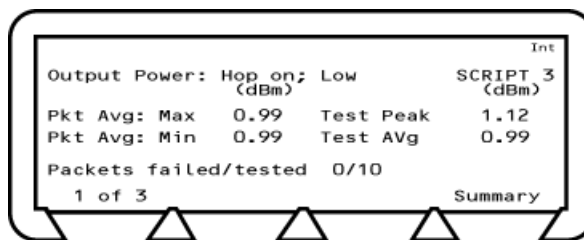

Figure 7-5. Output Powers Extended Results

- Page through the extended screens with the soft key in the normal manner, or press the [Summary] soft key to revert to the initial summary page.

Power Control Test

If “Test type” is set to “Loopback”, the MT8852B transmits a DH1 (or user-defined packet type) with a pseudo random data payload (PRBS 9).

If “Test type” is set to “Tx mode”, the MT8852B sends a Poll packet to the EUT which responds with a packet as defined in the “Packet type” field.

A power measurement cycle sets the EUT output power to its maximum, steps it down to the minimum, and then back to the maximum, one step at a time. For each power step a number of data packets are sent to the EUT and looped back to the MT8852B.

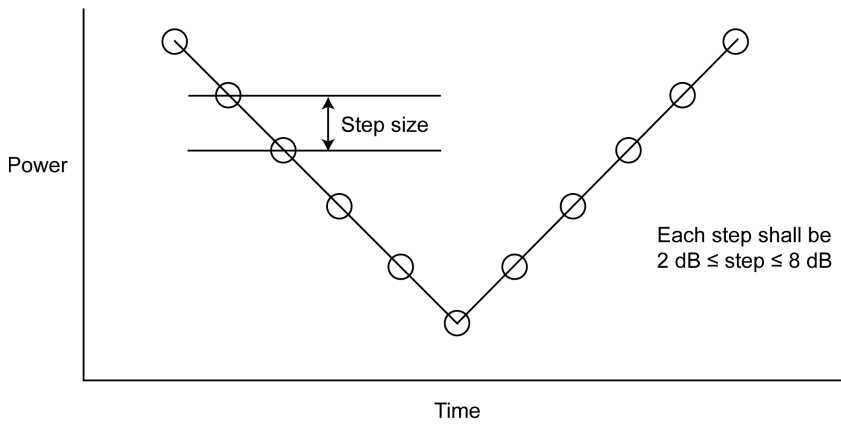

Figure 7-6. Power Control Test

The table below details the test conditions and the associated default settings. Permitted variations from the default setting are detailed in the “User Range” column.

Table 7-3. Power Control Test Conditions

Parameter	Default value	User Range
Cycles	1	1 to 10,000
Test type	Loopback	Loopback, TX mode
Packet type	DH1	DH1, DH3, DH5
Packets per step	1	1 to 10,000
Minimum test power	-35 dBm	-40 dBm to 0.0 dBm
Measurement delay	0.1 s	0.1 s to 100 s

Results

1. Position the Cursor at "Power control" in the Script menu.
2. Press the [Results] soft key.

The Power control results page displays.

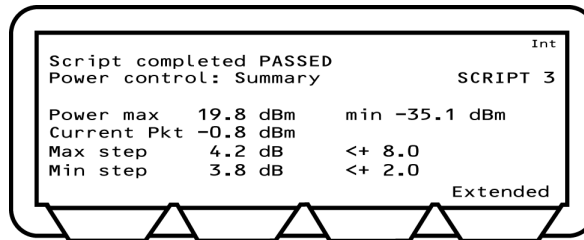

Figure 7-7. Power Control Results

- Power max: Displays the maximum power that the EUT reached in the test.
- Power min: Displays the minimum power the EUT reached in the test.
- Current Pkt: Displays the average power of the last packet measured by the MT8852B. The MT8852B identifies the position of the first bit (p0) in the packet and measures the power in each individual bit. Packet avg is the average power of all the measured bits.
- Max step: Displays the largest change between the power level steps.
- Min step: Display the smallest change between the power level steps.
3. Press the [Extended] soft key to display more detailed test results. Unlike the summary page shown above, the extended pages are specific to each frequency.

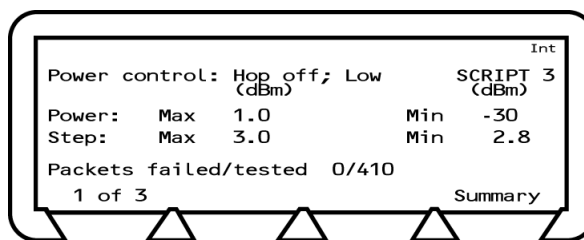

Figure 7-8. Power Control Extended Results

4. Page through the extended screens with the soft key in the normal manner, or press the [Summary] soft key to revert to the initial summary page.

Enhanced Power Control Test

The enhanced power control test performs power measurement cycles on the EUT output at each of the defined frequencies (LOW, MEDIUM and HIGH).

The MT8852B transmits a DH1 (or user-defined packet type) with a pseudo random data payload (PRBS 9), then a 2-DH1 and then a 3-DH1 packet at the power step levels. These are looped back by the EUT and measured by the MT8582B.

A power measurement cycle sets the EUT output power to its maximum, steps it down to the minimum, and then back to the maximum, one step at a time. For each power step a number of data packets are sent to the EUT and looped back to the MT8852B.

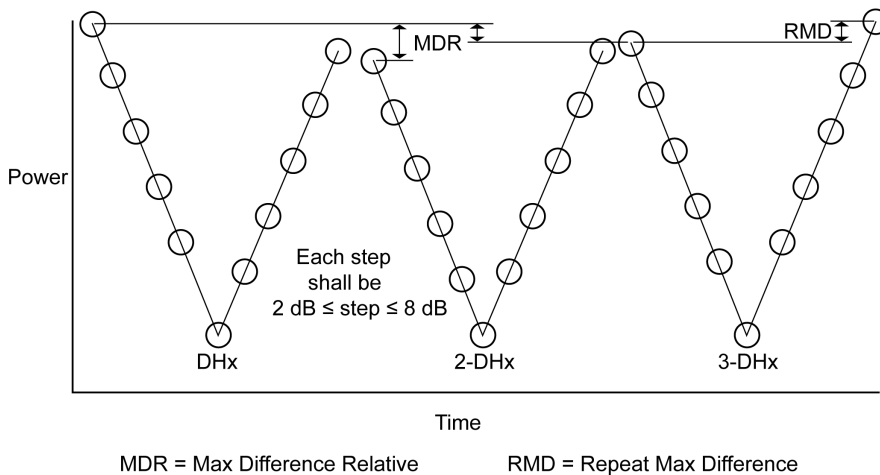

Figure 7-9. Enhanced Power Control Test

The table below details the test conditions and the associated default settings. Permitted variations from the default setting are detailed in the “User Range” column.

Table 7-4. Enhanced Power Control Test Conditions

Parameter	Default value	User Range
Cycles	1	1 to 10,000
Test type	Loopback	Loopback, TX mode
Packet type	GFSK: DH1	DH1, DH3, DH5
	2Mbps: 2DH1	2DH1, 2DH3, 2DH5, OFF, Longest
	3Mbps: 3DH1	3DH1, 3DH3, 3DH5, OFF, Longest
Packets per step	1	1 to 10,000
Minimum test power	-35.0 dBm	-40 dBm to 0.0 dBm

Results

1. Position the cursor at "Enhanced Power control" in the Script menu.
2. Press the [Results] soft key.

The Enhanced Power control results page displays.

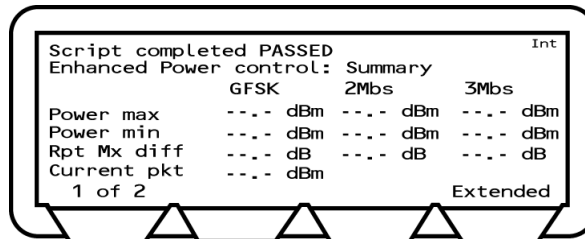

Figure 7-10. Enhanced Power Control Results

- Power max:** Displays the maximum power that the EUT reached in the test.
- Power min:** Displays the minimum power that the EUT reached in the test.
- Rpt Mx diff:** Displays the maximum power level at the start of a given modulation measurement cycle relative to the maximum power at the end of the cycle. Shown as "RMD" in figure 7-9.
- Current Pkt:** Displays the average power of the last packet measured by the MT8852B. The MT8852B identifies the position of the first bit (p0) in the packet and measures the power in each individual bit. Packet avg is the average power of all the measured bits.

Press the [1 of 2] soft key to display the second page of results.

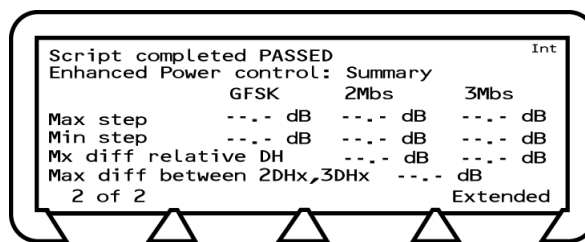
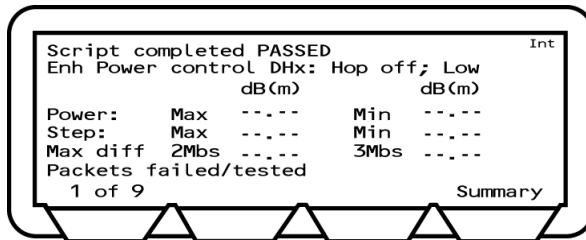

Figure 7-11. Enhanced Power Control Results 2

- Max step:** Displays the largest change between the power level steps.
- Min step:** Display the smallest change between the power level steps.
- Mx diff relative:** Displays the maximum difference (at the same step position) in the GFSK header power for DHx to 2-DHx, and DHx to 3-DHx packets. Shown as "MDR" in figure 7-9.
- Max diff:** Displays the maximum recorded difference between the 2 and 3 Mbs results.

3. Press the [Extended] soft key to display more detailed test results. Unlike the summary page shown above, the extended pages are specific to each frequency.



```
Script completed PASSED                               Int
Enh Power control DHx: Hop off; Low
                                dB(m)                dB(m)
Power:      Max  ----   Min  ----
Step:       Max  ----   Min  ----
Max diff 2Mbs ----   3Mbs ----
Packets failed/tested
          1 of 9                                     Summary
```

Figure 7-12. Enhanced Power Control Extended Results

4. Page through the extended screens with the soft key in the normal manner, or press the [Summary] soft key to revert to the initial summary page.

Initial Carrier Test

If “Test type” is set to “Loopback”, the initial carrier test performs a frequency accuracy test on a DH1 pseudo random data packet (PRBS9).

If “Test type” is set to “Tx mode”, the MT8852B sends a Poll packet to the EUT which responds with a packet as defined in the “Packet type” field.

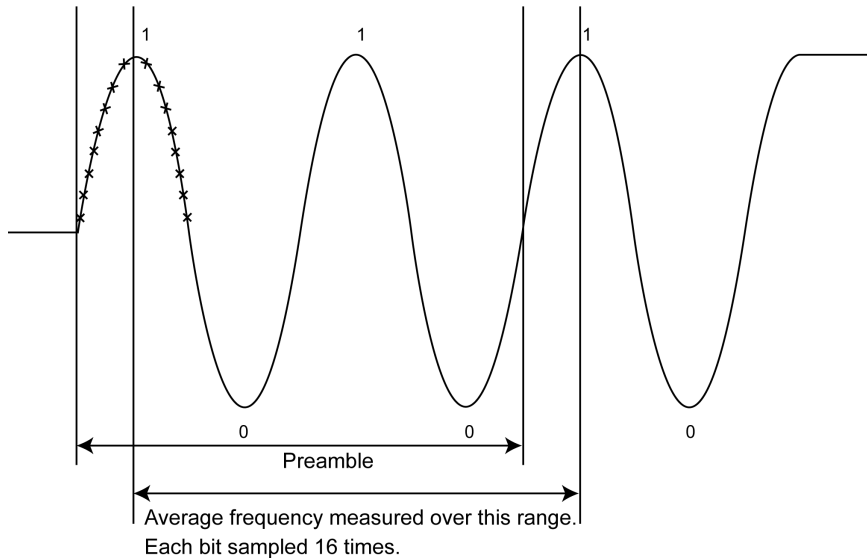

Figure 7-13. Initial Carrier Test

The table below details the test conditions and the associated default settings. Permitted variations from the default setting are detailed in the “User Range” column.

Table 7-5. Initial Carrier Test Conditions

Parameter	Default value	User Range
Hopping	ON	ON, ON&OFF, OFF
Hopping test mode	Defined	Defined, All, Any
Test type	Loopback	Loopback, TX mode
Number of packets	10	1 to 10,000

Results

1. Position the cursor at "Init carrier" in the Script menu.
2. Press the [Results] soft key.

The Initial carrier results pages display.

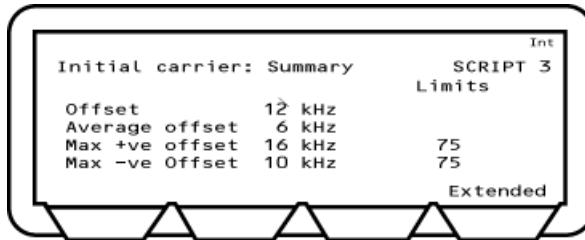

Figure 7-14. Initial Carrier Results

Offset: Displays the initial frequency error of the last packet measured.

Average offset: Displays the average value of all initial frequency offset measurements made in the test.

Max +ve offset: Displays the frequency error of the single packet that had the greatest positive error of all those measured.

Max -ve offset: Displays the frequency error of the single packet that had the greatest negative error of all those measured.

- Press the [Extended] soft key to display more detailed test results. Unlike the summary page shown above, the extended pages are specific to each of the test scenarios. For example, if a test is performed at high, medium, and low frequencies, with hopping both on and off, there would be six extended pages. An example of the first extended page for the initial carrier test is shown below.

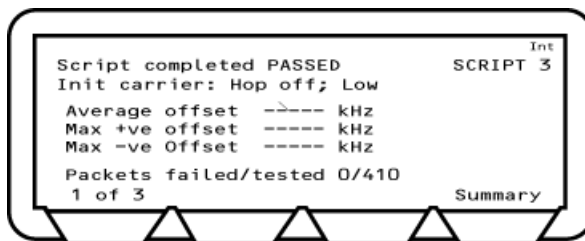

Figure 7-15. Initial Carrier Extended Results

- Page through the extended screens with the soft key in the normal manner, or press the [Summary] soft key to revert to the initial summary page.

Carrier Drift Test

In this test, the EUT loops back DH1, DH3, and DH5 packets with a fixed 10101010 payload. The carrier drift test performs a frequency drift measurement over the length of the packet received.

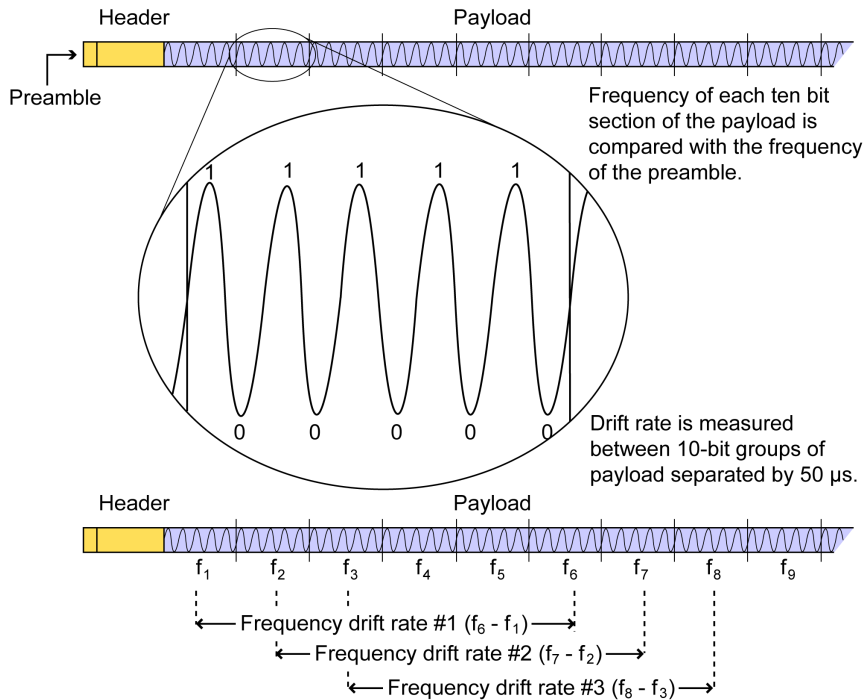

Figure 7-16. Carrier Drift Test

The table below details the test conditions and the associated default settings. Permitted variations from the default setting are detailed in the “User Range” column.

Table 7-6. Carrier Drift Test Conditions

Parameter	Default value	User Range
Hopping	ON	ON, ON&OFF, OFF
Hopping test mode	Defined	Defined, All, Any
Test type	Loopback	Loopback, TX mode
Packet type	1, 3, & 5	[1], [3], [1&3], [5], [1&5], [3&5], [1,3&5]
Number of packets	10	1 to 10,000

Results

1. Position the cursor at "Carrier drift" in the Script menu.
2. Press the [Results] soft key.

The Carrier drift results page displays.

		Limits		
Script completed PASSED				
Carrier drift: Summary		SCRIPT 3		Int
Drift rate	2143 kHz/50us	+/- 20	PASS	
Drift (DH1)	16 kHz/50us	+/- 25	PASS	
Drift (DH3)	21 kHz/50us	+/- 40	PASS	
Drift (DH5)	22 kHz/50us	+/- 20	PASS	
				Extended

Figure 7-17. Carrier Drift Results

Drift rate: Displays the maximum drift rate between any two 10-bit groups in the packet, separated by 50 us. This value is the peak held worst-case value for packets measured during the test.

Drift (DHx): Displays the difference between the average frequency of the first 4 preamble bits of the packet and the average frequency of any 10 bits in the payload field of the same packet. This value is the peak held worst-case value for packets measured during the test.

- Press the [Extended] soft key to display more detailed test results. Unlike the summary page shown above, the extended pages are specific to each of the test scenarios. For example, if a test is performed at high, medium, and low frequencies, with hopping both on and off, there would be six extended pages. An example of the first extended page for the carrier drift test is shown below.

		DH1	DH3	DH5
Script completed PASSED				
Carrier drift: Hop on; Low		SCRIPT 3		Int
Max rate:		2.85	4.50	5.32
Max drift:		-10	-11	-11
Avg Drift:		-3	-7	-7
Packets failed/tested		0/30		
1 of 3				Summary

Figure 7-18. Carrier Drift Extended Results

Note "Packets Tested" refers to the total of all packets tested (i.e., at DH1, DH3, and DH5).

- Page through the extended screens with the soft key in the normal manner, or press the [Summary] soft key to revert to the initial summary page.

Single Sensitivity Test

The MT8852B transmits DH1 packets with a pseudo random payload (PRBS9) to the EUT at a defined power level (-70 dBm by default). If the dirty transmitter parameters are applied, then every 20 ms the MT8852B changes the transmitter parameters as specified in the dirty transmitter table for this test. The EUT loops back the received data to the MT8852B at its maximum power where bit error rate (BER) and frame error rate (FER) calculations are performed. The test is repeated with hopping off for each of the frequencies selected (LOW, MEDIUM and HIGH) and then with hopping on.

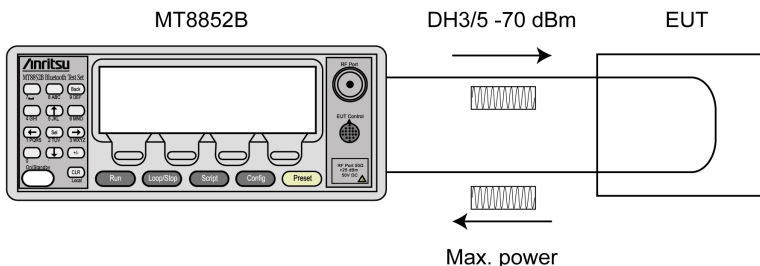

Figure 7-19. Single Sensitivity Test

The table below details the test conditions and the associated default settings. Permitted variations from the default setting are detailed in the “User Range” column.

Table 7-7. Single Sensitivity Test Conditions

Parameter	Default value	User Range
Number of packets	7408	1 to 10,000
Test Tx power	-70.0 dBm	-90 dBm to 0.0 dBm
Payload pkt count	Transmitted	Transmitted, Received
Hopping	OFF&ON	ON, OFF&ON, OFF
Dirty transmitter	OFF	OFF, ON

Results

1. Position the cursor at "Single sensitivity" in the Script menu.
2. Press the [Results] soft key.

The Single sensitivity results page displays.

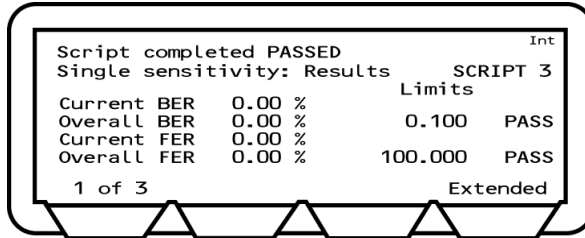

Figure 7-20. Single Sensitivity Results 1

Current BER: Displays the BER as measured in the last 20 returned packets.

Overall BER: Displays the BER for all the returned packets.

Current FER: Displays the FER as measured in the last 20 returned packets.

Overall FER: Displays the FER for all the returned packets.

3. Press the [1 of 3] soft key to display the second page.

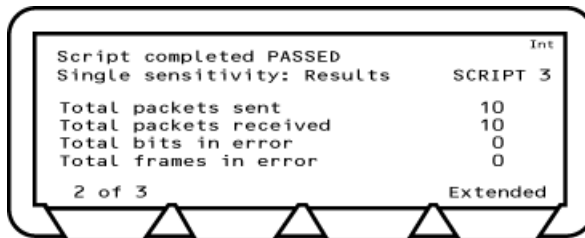

Figure 7-21. Single Sensitivity Results 2

4. Press the [2 of 3] soft key to display the third page.

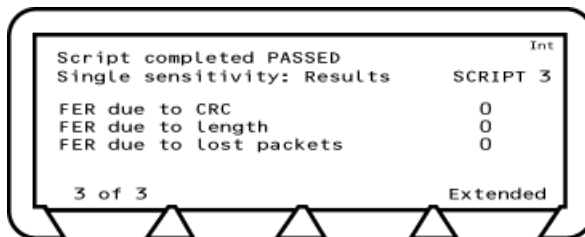

Figure 7-22. Single Sensitivity Results 3

FER due to CRC: Displays the number of packets returned that had a Cyclic Redundancy Check (CRC) error. These packets are used in BER calculations.

FER due to length: Displays the number of packets returned with incorrect payload lengths. This will also result in a CRC error. These packets are used in BER calculations.

FER due to lost packets: A lost packet is counted by the MT8852B under the following conditions:

- Not recognizing the sync word header as being correct.
- The packet failing the Header Error Correction (HEC)
- No packet received during the expected time slot.
- NACK packet is received.

These packets are not used in BER calculations.

5. Press the [Extended] soft key to display more detailed test results. An example of the first extended page for the single sensitivity test is shown below.

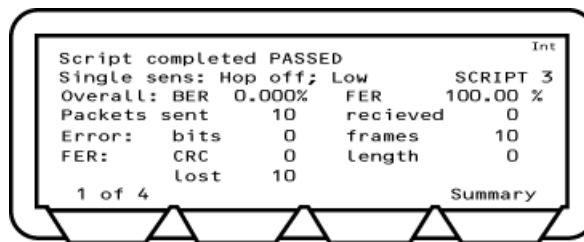

Figure 7-23. Single Sensitivity Extended Results

6. Page through the extended screens with the soft key in the normal manner, or press the [Summary] soft key to revert to the initial summary page.

Multi Slot Sensitivity Test

The MT8852B transmits the longest supported packet type with a PRBS9 payload to the EUT at a defined power level (-70 dBm by default). If the dirty parameters are enabled then every 20 ms the MT8852B changes the transmitter parameters as specified in the dirty transmitter table for this test. The EUT loops back the received data and a bit error rate (BER) calculation and frame error rate (FER) calculation is performed by the MT8852B test set.

The test is repeated with hopping off for each of the frequencies selected (LOW, MEDIUM and HIGH) and then with hopping on.

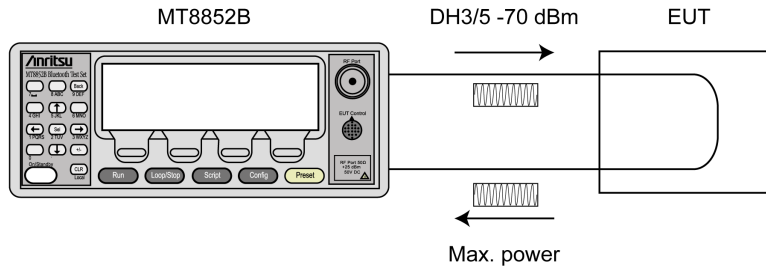

Figure 7-24. Multi Slot Sensitivity Test

The table below details the test conditions and the associated default settings. Permitted variations from the default setting are detailed in the “User Range” column.

Table 7-8. Multi Sensitivity Test Conditions

Parameter	Default value	User Range
Number of packets	590 (127400 bits)	1 to 10,000
Test Tx power	-70.0 dBm	-90 dBm to 0.0 dBm
Payload pkt count	Transmitted	Transmitted, Received
Packet type	Longest	Longest, DH3, DH5
Hopping	OFF&ON	ON, OFF&ON, OFF
Dirty transmitter	OFF	OFF, ON

Results

1. Position the cursor at "Multi sensitivity" in the Script menu.
2. Press the [Results] soft key.

The Multi sensitivity results page displays.

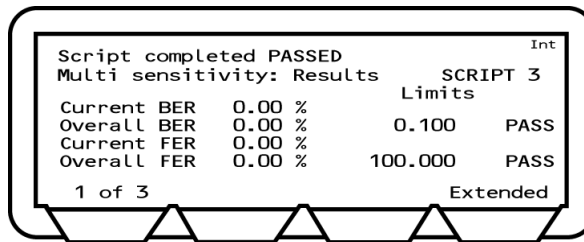

Figure 7-25. Multi Sensitivity Results 1

Current BER: Displays the BER as measured in the last 10 returned packets.

Overall BER: Displays the BER for all the returned packets.

Current FER: Displays the FER as measured in the last 10 returned packets.

Overall FER: Displays the FER for all the returned packets.

3. Press the [1 of 3] soft key to move to the second page.

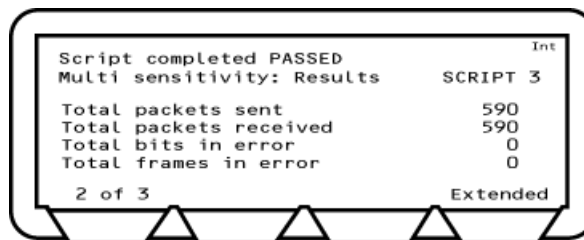

Figure 7-26. Multi Sensitivity Results 2

4. Press the [2 of 3] soft key to move to the third page.

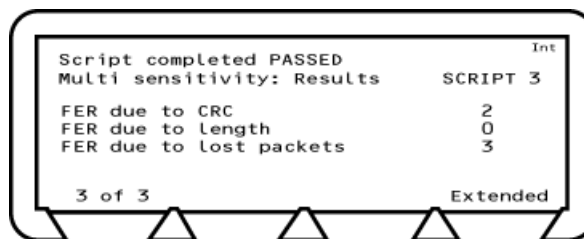

Figure 7-27. Multi Sensitivity Results 3

FER due to CRC: Displays the number of packets returned that had a Cyclic Redundancy Check (CRC) error. These packets are used in BER calculations.

FER due to length: Displays the number of packets returned with incorrect payload lengths. This will also result in a CRC error. These packets are used in BER calculations.

FER due to lost packets: A lost packet will result from the MT8852B under the following conditions:

- Not recognizing the sync word header as being correct.
- The packet failing the Header Error Correction (HEC)
- No packet received during the expected time slot.
- NACK packet is received.

These packets are not used in BER calculations.

5. Press the [Extended] soft key to display more detailed test results. An example of the first extended page for the multi sensitivity test is shown below.

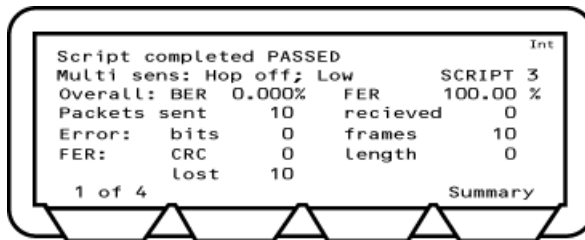

Figure 7-28. Multi Sensitivity Extended Results

6. Page through the extended screens with the soft key in the normal manner, or press the [Summary] soft key to revert to the initial summary page.

Modulation Index Test

This test measures the modulation characteristics on the EUT output for each of the selected frequency ranges (LOW, MEDIUM and HIGH).

The MT8852B first transmits packets containing the four ones four zeros payload (11110000), which are looped back by the EUT.

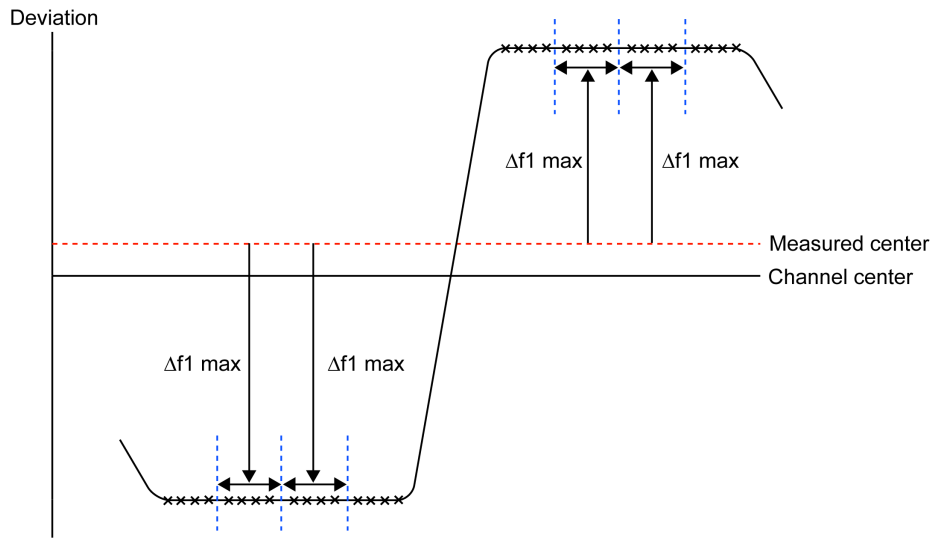

Figure 7-29. Modulation Index Test (11110000)

The MT8852B calculates the average frequency of each 11110000 payload section. It measures the deviation from the average frequency for bits 2, 3, 6, and 7. These values are called $\Delta f1$ max values.

Following measurement of the 11110000 payload, packets with the alternate ones and zeros (10101010) payload are transmitted and are looped back by the EUT.

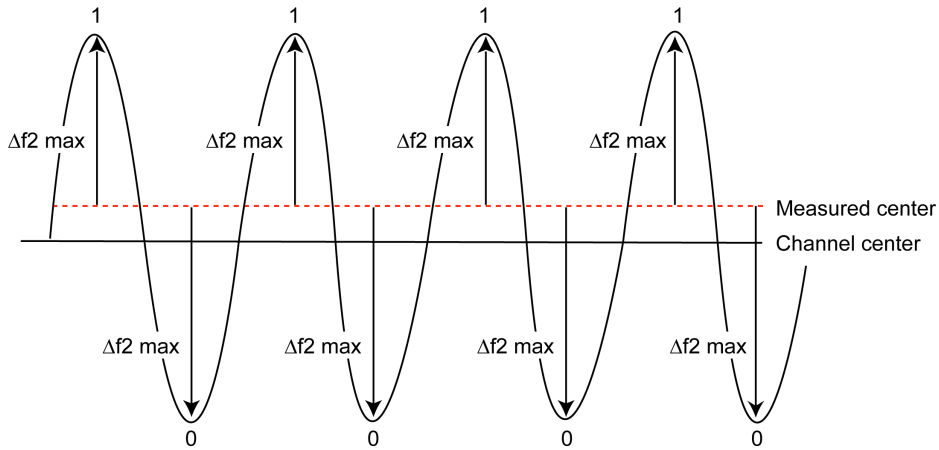

Figure 7-30. Modulation Index Test (10101010)

The MT8852B calculates the average frequency of each 10101010 8-bit payload section. Then it measures the deviation from the average frequency values for all 8-bits. These values are called $\Delta f2$ max values.

This test is performed with hopping off, and the test is repeated until the number of packets has been measured on each of the selected frequencies as set in the "Number of packets" field.

The table below details the test conditions and the associated default settings. Permitted variations from the default setting are detailed in the "User Range" column.

Table 7-9. Modulation Index Test Conditions

Parameter	Default value	User Range
Test type	Loopback	Loopback, TX mode
Packet type	Longest	Longest, DH1, DH3, DH5
Number of packets	10	1 to 10,000
Toggle payload	Once	Once, Continuous

Results

1. Position the cursor at "Modulation index" in the Script menu.
2. Press the [Results] soft key.

The results page displays.

Modulation index: Results		SCRIPT 3
	(kHz)	Limits
f1 avg	168.2	140<=f1<=175 PASS
f2 avg	154.8	
f2 max	122.6	100.00%>=155 PASS
f2avg/f1avg	0.83	>=0.8 PASS

Figure 7-31. Modulation Index Results

- F1 avg:** The MT8852B measures the maximum deviation for the second, third, sixth and seventh bit of each 11110000 payload byte ($\Delta f1$ max). It then calculates the average value of all these deviations for each packet. This value is recorded as F1avg for each packet. The displayed value on the MT8852B is the highest F1 avg value of all the packets that have been measured.
- F2 avg:** The MT8852B measures the maximum deviation of each 10101010 bit in the payload ($\Delta f2$ max). The average of all these maximum deviations is then calculated and recorded as F2avg.
- F2 max:** The MT8852B measures the maximum deviation of each 10101010 bit in the payload. Each of these values is recorded as an F2max value. The displayed value of F2max is the single bit measured in a test that has the lowest recorded deviation. The percentage of F2max values that are greater than the limit of 115 kHz is also displayed. The pass/fail criteria is made relative to the percentage value passed, and should exceed 99.9%.

Note Pattern errors found in either the 11110000 or 10101010 payload are discarded.

- Press the [Extended] soft key to display more detailed test results. An example of the first extended page for the modulation index test is shown below.

Modulation idx: Hop off; Low		SCRIPT 3
	(kHz)	(kHz)
f1 avg	154.4	f2 avg 139.1
f1 max	156.6	f2 max 134.4
f2avg/f1avg	0.90	f2 pass% 100.00
Packets Failed/Tested		0/20
1 of 3		Summary

Figure 7-32. Modulation Index Extended Results

- Page through the extended screens with the soft key in the normal manner, or press the [Summary] soft key to revert to the initial summary page.

Maximum Input Power Test

The MT8852B transmits a DH1 data packet to the EUT with a PRBS9 payload so that the EUT receives the signal at a power level of -20 dBm. The EUT loops back the received data and a bit error rate (BER) and frame error rate (FER) calculation is performed by the MT8852B. The test is repeated for each of the frequency ranges selected (LOW, MEDIUM and HIGH). This test is performed with hopping off.

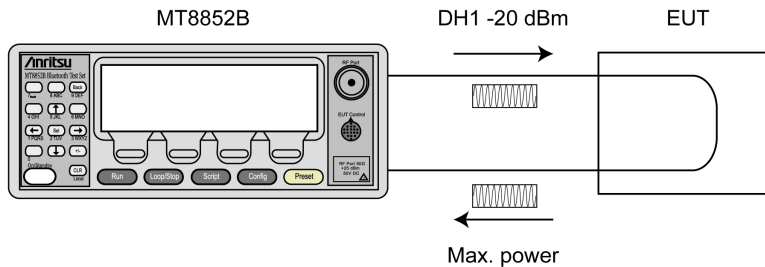

Figure 7-33. Maximum Input Power Test

The table below details the test conditions and the associated default settings. Permitted variations from the default setting are detailed in the “User Range” column.

Table 7-10. Maximum Input Power Test Conditions

Parameter	Default value	User Range
Number of packets	7408 (1600128 bits)	1 to 10,000
Test tx power	-20 dBm	-90 dBm to 0.0 dBm
Payload pkt count	Transmitted	Transmitted, Received

Results

1. Position the cursor at "Max input power" in the Script menu.
2. Press the [Results] soft key.

The Maximum input power results page displays.

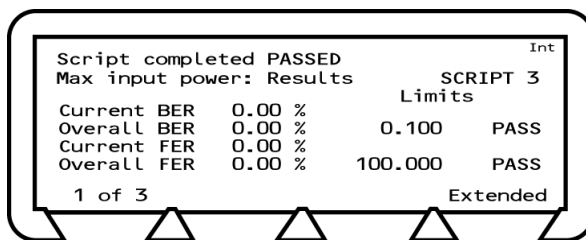

Figure 7-34. Max Input Power Results 1

Current BER: Displays the BER as measured in the last 10 returned packets.

Overall BER: Displays the BER for all the returned packets.

Current FER: Displays the FER as measured in the last 10 returned packets.

3. Press the [1 of 3] soft key to move to the second page.

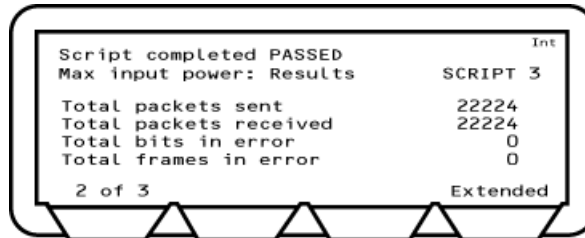

Figure 7-35. Max Input Power Results 2

4. Press the [2 of 3] soft key to move to the third page.

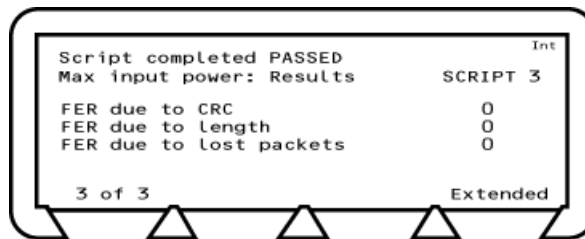

Figure 7-36. Max Input Power Results 3

FER due to CRC: Displays the number of packets returned that had a Cyclic Redundancy Check (CRC) error. These packets are used in BER calculations.

FER due to length: Displays the number of packets returned with incorrect payload lengths. This will also result in a CRC error. These packets are used in BER calculations.

FER due to lost packets: A lost packet will result from the MT8852B under the following conditions:

- Not recognizing the sync word header as being correct.
- The packet failing the Header Error Correction (HEC)
- No packet received during the expected time slot.
- NACK packet is received.

5. Press the [Extended] soft key to display more detailed test results. An example of the first extended page for the maximum input test is shown below.

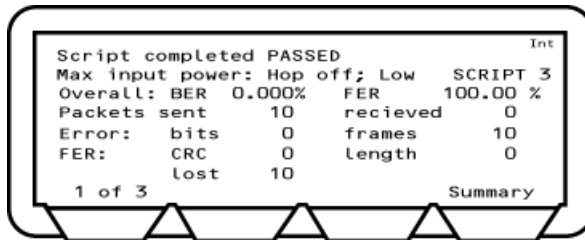

Figure 7-37. Max Input Power Extended Results

6. Page through the extended screens with the soft key in the normal manner, or press the [Summary] soft key to revert to the initial summary page.

7-6 Enhanced Data Rate Tests

(MT8852B and MT8852B-42 only)

EDR Relative Tx Power Test

The EDR relative transmit power test ensures that the difference in average transmit power during the frequency modulated [GFSK] and phase modulated [PSK] parts of a packet is within the range: $(P_{\text{GFSK}} - 4 \text{ dB}) < P_{\text{DPSK}} < (P_{\text{GFSK}} + 1 \text{ dB})$.

If the EUT supports both $\pi/4$ DQPSK and 8DPSK modulation, the test must be performed on both modulation formats using the longest support packet type.

The test must be performed with the EUT transmitting at its maximum power, and if the EUT supports power control, also at its minimum transmitter power level. The MT8852B sets the EUT to the Max and Min transmit power automatically if the EUT reports that it supports power control and both Max and Min have been selected in the "EUT power level" entry field.

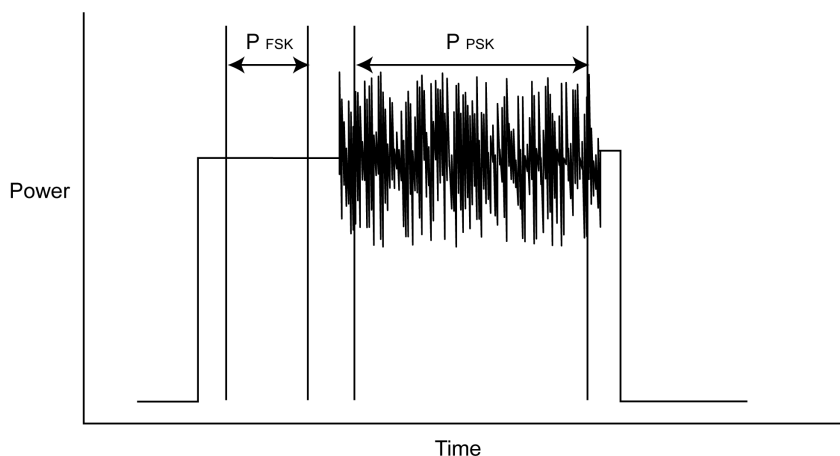

Figure 7-38. EDR Relative Tx Power Test

The table below details the test conditions and the associated default settings. Permitted variations from the default setting are detailed in the "User Range" column.

Table 7-11. EDR Relative Tx Power Test Conditions

Parameter	Default value	User Range
Number of packets	10	1 to 10,000
DHx packet type	2 Mbs: Longest	2DH1, 2DH3, 2DH5, OFF, Longest
	3 Mbs: Longest	3DH1, 3DH3, 3DH5, OFF, Longest
Hopping	Off	Off, On, Off & On
Hopping test mode	Defined	Defined, All, Any

Table 7-11. EDR Relative Tx Power Test Conditions

Parameter	Default value	User Range
Test type	Loopback	Loopback, Tx Mode
EUT power level	Max & Min	Min, Max, Max & Min
Min sensitivity check	False	False, True

Results

1. Position the cursor at "Rel Tx power" in the EDR Script menu.
2. Press the [Results] soft key.

The Rel Tx power results page displays.

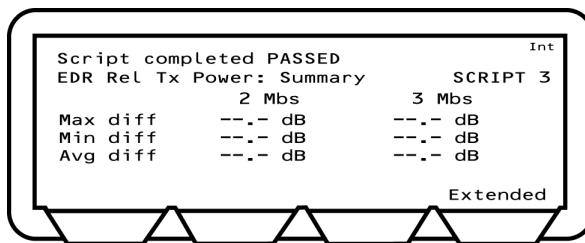
**Figure 7-39.** EDR Relative Tx Power Results

- Max diff: Displays the maximum power difference between the GFSK and the PSK parts of a packet measured for all the packets tested.
- Min diff: Displays the minimum power difference between the GFSK and the PSK parts of a packet measured for all the packets tested.
- Avg diff: Displays the average power difference between the GFSK and the PSK parts of a packet averaged over all the packets tested.

3. Press the [Extended] soft key to display more detailed test results. An example of the first extended page is shown below.

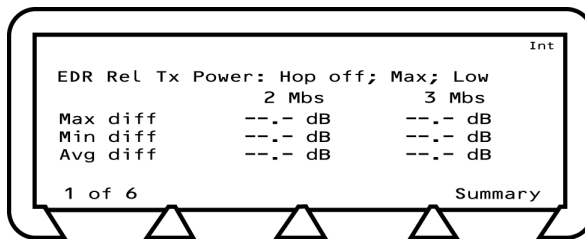
**Figure 7-40.** EDR Relative Tx Power Extended Results

4. Page through the extended screens with the soft key in the normal manner, or press the [Summary] soft key to revert to the initial summary page.

EDR Carrier & Modulation Test

This test verifies the transmitter carrier frequency stability and modulation accuracy. The test comprises of both a frequency measurement and a Differential Error Vector Magnitude (DEV M) measurement.

The frequency measurements defined are:-

- Initial frequency (ω_i): This is the frequency error of the EDR packet measured across the header part of the packet.
- Frequency Error (ω_o): This is the frequency difference between the Initial Frequency Error, and the average frequency of a 50 μ s block of payload data.
- Block frequency Error ($\omega_i + \omega_o$): This is the difference in frequency between any single 50 μ s payload block, and the header for the same packet.

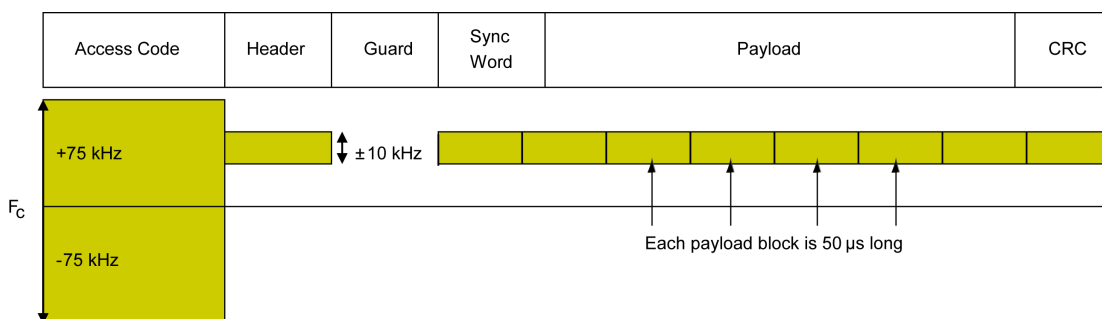

Figure 7-41. Frequency Measurement

The modulation measurements defined are;

- RMS DEV M. This is the average DEV M for all the symbols in each 50 μ s block measured. The result is calculated for each block, and each block must pass the following criteria, ≤ 0.20 for all $\pi/4$ DQPSK blocks and ≤ 0.13 for all 8DPSK blocks.
- Peak DEV M. This is the DEV M value of the single symbol in all the blocks measured that has the highest value. The pass criterion is ≤ 0.35 for all $\pi/4$ DQPSK symbols and ≤ 0.25 for all 8DPSK symbols.
- 99% DEV M. This is the percentage of symbols measured in all the blocks that pass the following limit. The pass criterion is 99% of all symbols are ≤ 0.30 for all $\pi/4$ DQPSK symbols, and 99% of all symbols are ≤ 0.20 for all 8DPSK symbols.

The default criteria for this test is that the longest supported $\pi/4$ DQPSK and the longest support 8DPSK packets must both be tested in loopback mode with hopping off.

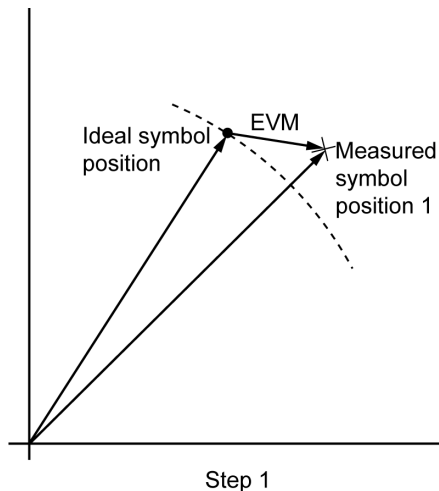

Figure 7-42. EVM Measurement

The diagram above illustrates the definition of EVM. For EVM measurements, the ideal symbol points are the same for every sequential symbol. In comparison, for DEVM measurements, the actual symbol position of the current symbol is used as the ideal position from which EVM measurements are made for the subsequent symbol. In the figure above, DEVM for the next symbol would be measured relative to “Measured symbol position 1” rather than to “Ideal symbol position”.

The table below details the test conditions and the associated default settings. Permitted variations from the default setting are detailed in the “User Range” column.

Table 7-12. EDR Carrier and Modulation Test Conditions

Parameter	Default value	User Range
Number of blocks	200	1 to 500
DHx packet type	2 Mbs: Longest	2DH1, 2DH3, 2DH5, OFF, Longest
	3 Mbs: Longest	3DH1, 3DH3, 3DH5, OFF, Longest
Hopping	Off	Off, On, Off & On
Hopping test mode	Defined	Defined, All, Any
Test type	Loopback	Loopback, Tx Mode

Results

1. Position the cursor at "Carrier & mod" in the EDR Script menu.

2. Press the [Results] soft key.

The Carrier & mod power results page displays.

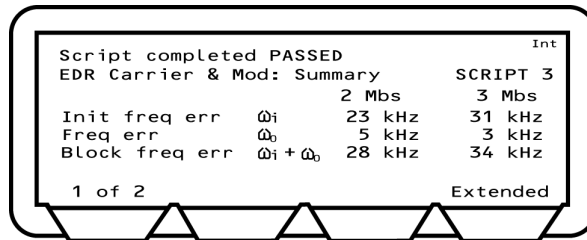

Figure 7-43. EDR Carrier & Modulation Results 1

- Init freq err:** The initial frequency value (known as ω_i) is the frequency error of the EDR packet measured across the header part of the packet. The error value displays as the difference between the ideal frequency for the measured channel and the measured frequency over the header part of the packet. If more than one packet is measured, the value displayed is the greatest frequency error measured of all packets tested.
- Freq err:** The Frequency Error value (known as ω_o) is the frequency difference between the Initial Frequency Error, and the average frequency of a 50 μ s block of payload data. The MT8852B divides the payload data into 50 μ s blocks and packets are looped back until 200 blocks have been measured. The value displayed is the greatest difference measured between any single 50 μ s payload block and the Initial Frequency error for the same packet.
- Block freq err:** The block frequency Error ($\omega_i + \omega_o$) is the difference in frequency between any single 50 μ s payload block, and the header for the same packet. The MT8852B displays the greatest block frequency error for all the 200 blocks measured. As the block frequency error requires that each block is measured relative to the header from the same packet, it is possible that, when more than one packet is required to achieve the 200 measurement blocks, that the result for ($\omega_i + \omega_o$) will not equal the sum of the displayed values of ω_i and ω_o .

3. Press the [1 of 2] soft key to move to the second page.

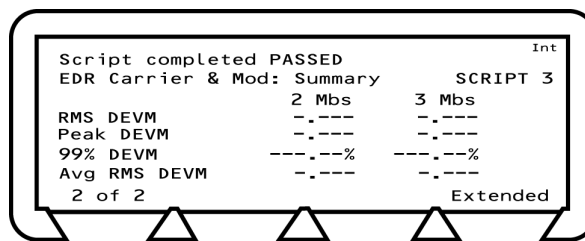

Figure 7-44. EDR Carrier & Modulation Results 2

- RMS DEVM:** The MT8852B measures the RMS DEVM of 200 blocks of payload data, each block being 50 μ s long. The displayed value of RMS DEVM is the greatest value as calculated for each of the 200 blocks individually.
- Peak DEVM:** The peak DEVM value is the DEVM value of the single symbol in all the blocks measured that has the greatest value.
- 99% DEVM:** The 99% DEVM is the percentage of symbols measured in all the blocks tested that are greater than the defined value (default conditions, 0.3 for $\pi/4$ DQPSK and 0.2 for 8DPSK).
- Avg RMS DEVM:** This value is not specified in the *Bluetooth* test specification. It is defined as being the average value of all the RMS DEVM values measured in the "RMS DEVM" result. The purpose of this measurement is to indicate if the RMS DEVM value is typical of the performance of all the blocks measured, or if it represents a single large value.
4. Press the [Extended] soft key to display more detailed test results. An example of the first extended page is shown below.

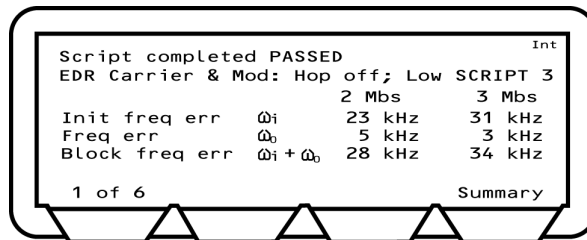

Figure 7-45. EDR Carrier & Modulation Extended Results

5. Page through the extended screens with the soft key in the normal manner, or press the [Summary] soft key to revert to the initial summary page.

EDR Differential Phase Test

In this test the EUT transmits a packet with a defined PRBS9 payload. The payload of the received packet is demodulated and compared with the defined ideal packet to give a resultant symbol error rate. The *Bluetooth* 2.0 specification stipulates that zero errors be detected in 99% of 100 packets transmitted. The specification requires this test to be performed only on 2-DH1 and 3-DH1 packets on channel 0.

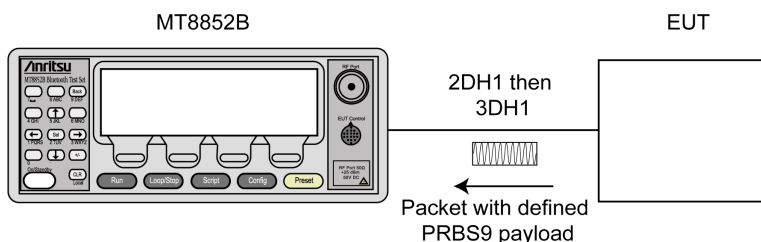

Figure 7-46. EDR Differential Phase Test

The table below details the test conditions and the associated default settings. Permitted variations from the default setting are detailed in the “User Range” column.

Table 7-13. EDR Differential Phase Test Conditions

Parameter	Default value	User Range
Number of packets	100	1 to 10,000
DHx packet type	2 Mbs: 2DH1	2DH1, 2DH3, 2DH5, OFF, Longest
	3 Mbs: 3DH1	3DH1, 3DH3, 3DH5, OFF, Longest
Hopping	Off	Off, On, Off & On

Results

1. Position the cursor at "Diff phase" in the EDR Script menu.
2. Press the [Results] soft key.

The Diff phase results page displays.

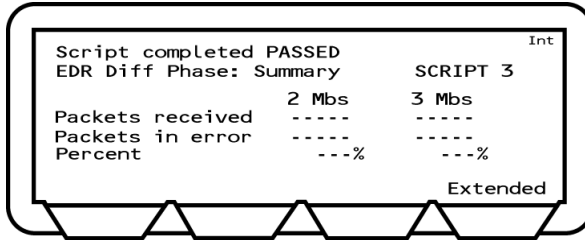

Figure 7-47. EDR Differential Phase Results

Packets received: The number of packets transmitted by the EUT and successfully received by the MT8852B

Packets in error: The number of packets received that had errors in the PRBS9 payload as detected by the MT8852B.

Percent: Ratio of packets received to packets in error.

3. Press the [Extended] soft key to display more detailed test results. An example of the first extended page is shown below.

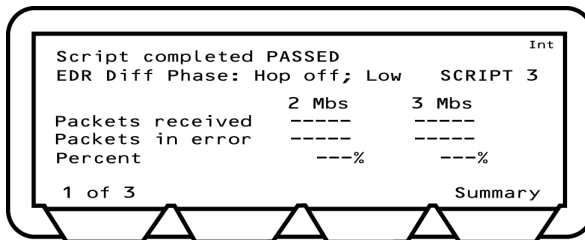

Figure 7-48. EDR Differential Phase Extended Results

4. Page through the extended screens with the soft key in the normal manner, or press the [Summary] soft key to revert to the initial summary page.

Note In the *Bluetooth* specification, this test is performed only on 2-DH1 and 3-DH1 packets on channel 0.

EDR Sensitivity Test

The sensitivity test checks the EUT receiver sensitivity performance in terms of bit error rate using a non-ideal (dirty) test signal. The test should be performed on the longest supported $\pi/4$ DQPSK and 8DPSK packets with frequency hopping off.

The signal source level is set so that the EUT receiver has an input level of -70dBm with defined signal impairments. At each of the test frequencies, the tester transmits packets to the EUT. The EUT loops the packets back to the tester until the tester has received 1,600,000 bits.

- If the BER measured is $\leq 7 \times 10^{-5}$ the test has passed and the test stops.
- If the BER is $\geq 7 \times 10^{-5}$ the test continues until the tester has received 16,000,000 bits.
- If the BER measured is $\leq 1 \times 10^{-4}$ the EUT has passed.

This pass criteria applies to each test frequency.

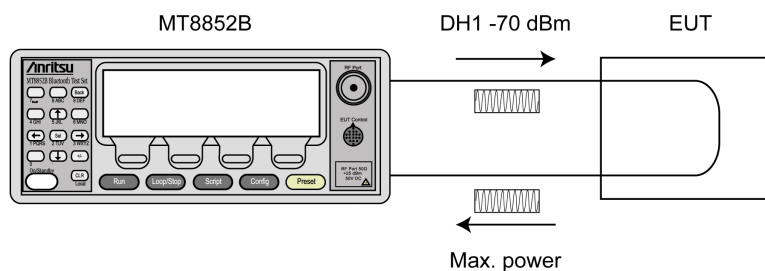

Figure 7-49. EDR Sensitivity Test

The table below details the test conditions and the associated default settings. Permitted variations from the default setting are detailed in the “User Range” column.

Table 7-14. EDR Sensitivity Test Conditions

Parameter	Default value	User Range
DHx packet type	2 Mbs: Longest	2DH1, 2DH3, 2DH5, OFF, Longest
	3 Mbs: Longest	3DH1, 3DH3, 3DH5, OFF, Longest
Dirty transmitter	On	Off, On
Hopping	Off	Off, On, Off & On
Payload pkt count	Transmitted	Transmitted, Received
Threshold bit count	1.6 Mbits	0.1 to 999.0 Mbits
Total test bit count	16 Mbits	0.1 to 999.0 Mbits
Tx power	-70.0 dBm	-90 dBm to 0.0 dBm

Results

1. Position the cursor at "EDR Sensitivity" in the EDR Script menu.
2. Press the [Results] soft key.

The EDR Sensitivity results page displays.

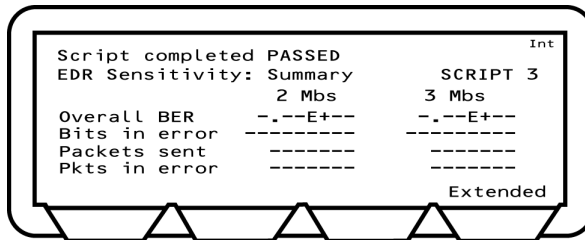

Figure 7-50. EDR Sensitivity Results

Overall BER: Number of payload bits received by the MT8852B in error as a percentage of the total number of payload bits received, expressed in exponent format. (0.01% displayed as 1 E-4). Note that according to the *Bluetooth* specification, packets not looped back by the EUT as a result of a sync check failure or header check failure are not included in the measurement.

Bits in error: The actual number of bits transmitted in error by the EUT.

Packets sent: The actual number of packets transmitted to the EUT by the MT8852B. This can be greater than the expected number if the EUT is dropping packets and the payload packet count is set to “Received”. This is because the MT8852B will continue to transmit packets until the EUT has looped back the required number of bits even if some packets are lost by the EUT.

Pkts in error: The number of packets incorrectly transmitted by the EUT. This includes, Nack'ed packets, Implicitly Nack'ed packets, packets with CRC errors, packets looped back with the incorrect length, and lost packets.

3. Press the [Extended] soft key to display more detailed test results. An example of the first extended page is shown below.

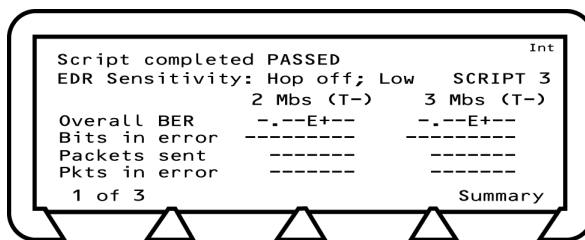

Figure 7-51. EDR Sensitivity Extended Results

4. Page through the extended screens with the soft key in the normal manner, or press the [Summary] soft key to revert to the initial summary page.

EDR BER Floor Test

The BER floor performance test checks whether the EUT receiver sensitivity has low residual BER performance when tested at a level 10dB above its minimum sensitivity. The test should be performed on the longest supported $\pi/4$ DQPSK and 8DPSK packets with frequency hopping off.

The signal source level is set so that the EUT receiver has an input level of -60dBm with no signal impairments. At each of the test frequencies, the tester transmits packets to the EUT. The EUT loops the packets back to the tester until the tester has received 8,000,000 bits.

- If the BER measured is $\leq 7 \times 10^{-6}$ the test has passed and the test stops.
- If the BER is $\geq 7 \times 10^{-5}$ the test continues until the tester has received 160,000,000 bits.
- If the BER measured is $\leq 1 \times 10^{-5}$ the EUT has passed.

This pass criteria applies to each test frequency.

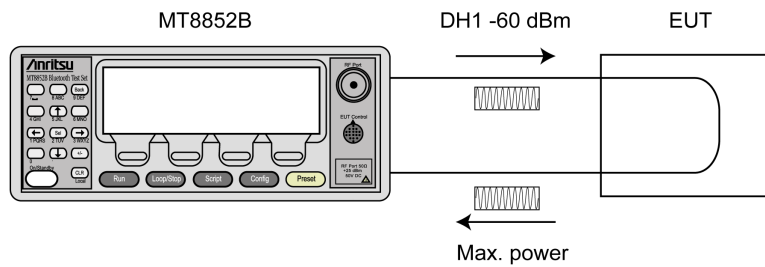

Figure 7-52. EDR BER Floor Test

The table below details the test conditions and the associated default settings. Permitted variations from the default setting are detailed in the “User Range” column.

Table 7-15. EDR BER Floor Test Conditions

Parameter	Default value	User Range
DHx packet type	2 Mbs: Longest	2DH1, 2DH3, 2DH5, OFF, Longest
	3 Mbs: Longest	3DH1, 3DH3, 3DH5, OFF, Longest
Payload pkt count	Transmitted	Transmitted, Received
Hopping	Off	Off, On, Off & On
Threshold bit count	8.0 Mbits	999
Total test bit count	16 Mbits	999
Tx power	-60 dBm	-90 dBm to 0.0 dBm

Results

1. Position the cursor at "EDR BER floor" in the EDR Script menu.

2. Press the [Results] soft key.

The EDR BER Floor results page displays.

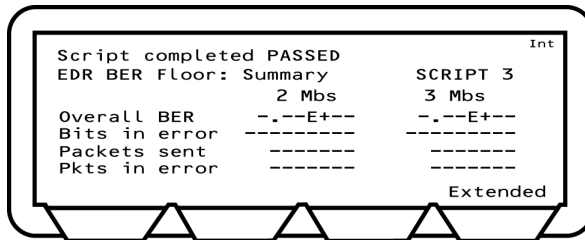

Figure 7-53. EDR BER Floor Results

Overall BER: Number of payload bits received by the MT8852B in error as a percentage of the total number of payload bits received, expressed in exponent format. (0.1% displayed as 1 E -4). Note that according to the *Bluetooth* specification, packets not looped back by the EUT as a result of a sync check failure or header check failure are not included in the measurement.

Bits in error: The actual number of bits transmitted in error by the EUT.

Packets sent: The actual number of packets transmitted to the EUT by the MT8852B. This can be greater than the expected number if the EUT is dropping packets and the payload packet count is set to "Received". This is because the MT8852B will continue to transmit packets until the EUT has looped back the required number of bits even if some packets are lost by the EUT.

Pkts in error: The number of packets incorrectly transmitted by the EUT. This includes, Nack'ed packets, Implicitly Nack'ed packets, packets with CRC errors, packets looped back with the incorrect length, and lost packets.

3. Press the [Extended] soft key to display more detailed test results. An example of the first extended page is shown below. (T-) in the figure below is used to indicate whether the test stopped at threshold 1 or 2..

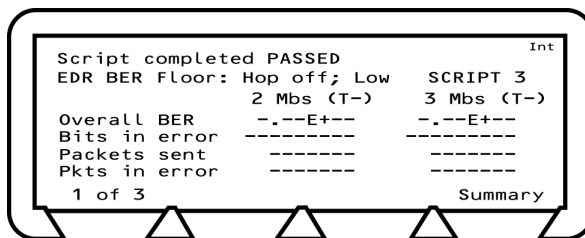

Figure 7-54. EDR BER Floor Extended Results

4. Page through the extended screens with the soft key in the normal manner, or press the [Summary] soft key to revert to the initial summary page.

EDR Max Input Test

The EDR Maximum input level test case check whether the EUT receiver sensitivity has low BER performance when tested at a high signal level close to its maximum specified input. The test should be performed on the longest supported $\pi/4$ DQPSK and 8DPSK packets with frequency hopping off.

The signal source level is set so that the EUT receiver has an input level of -20dBm with no signal impairments. At each of the test frequencies, the tester transmits packets to the EUT. The EUT loops back the packets to the tester until the tester has received 1,600,000 bits. The pass criterion is that the EUT BER shall be $\leq 1 \times 10^{-3}$. This pass criterion applies to each test frequency.

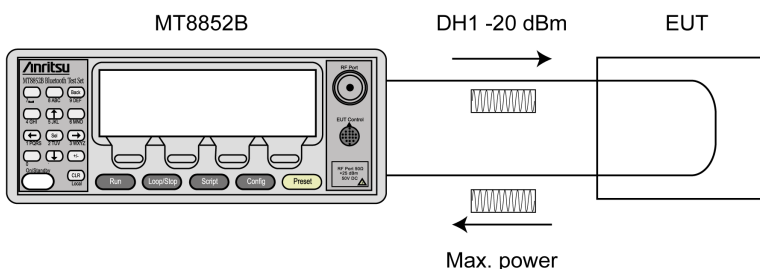

Figure 7-55. EDR Max Input Level Test

The table below details the test conditions and the associated default settings. Permitted variations from the default setting are detailed in the “User Range” column.

Table 7-16. EDR Max Input Level Test Conditions

Parameter	Default value	User Range
DHx packet type	2 Mbs: Longest	2DH1, 2DH3, 2DH5, OFF, Longest
	3 Mbs: Longest	3DH1, 3DH3, 3DH5, OFF, Longest
Tx power	-20.0 dBm	-90.0 dBm to 0.0 dBm
Number of bits	1.6 Mbits	0.1 Mbits to 999.0 Mbits
Hopping	Off	Off, On, Off & On
Payload pkt count	Transmitted	Transmitted, Received

Results

1. Position the cursor at "EDR Max input level" in the EDR Script menu.
2. Press the [Results] soft key.

The EDR Max input level results page displays.

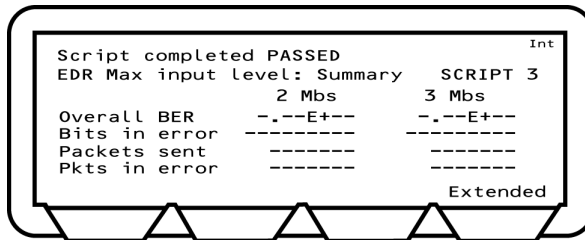

Figure 7-56. EDR Max Input Level Results

Overall BER: Number of payload bits received by the MT8852B in error as a percentage of the total number of payload bits received, expressed in exponent format. (0.1% displayed as 1 E -4). Note that according to the *Bluetooth* specification, packets not looped back by the EUT as a result of a sync check failure or header check failure are not included in the measurement.

Bits in error: The actual number of bits transmitted in error by the EUT.

Packets sent: The actual number of packets transmitted to the EUT by the MT8852B. This can be greater than the expected number if the EUT is dropping packets and the payload packet count is set to “Received”. This is because the MT8852B will continue to transmit packets until the EUT has looped back the required number of bits even if some packets are lost by the EUT.

Pkts in error: The number of packets incorrectly transmitted by the EUT. This includes, Nack'ed packets, Implicitly Nack'ed packets, packets with CRC errors, packets looped back with the incorrect length, and lost packets.

- Press the [Extended] soft key to display more detailed test results. Unlike the summary page shown above, the extended pages are specific to each of the test scenarios. For example, if a test is performed at high, medium, and low frequencies, with hopping both on and off, there would be six extended pages. An example of the first extended page is shown below.

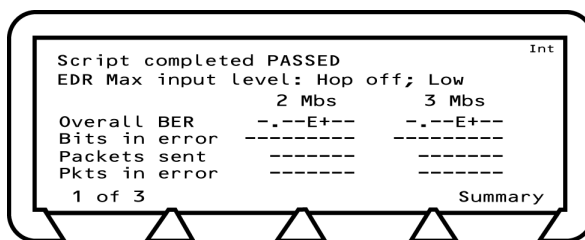

Figure 7-57. EDR Max Input Level Results Extended

- Page through the extended screens with the soft key in the normal manner, or press the [Summary] soft key to revert to the initial summary page.

7-7 Low Energy Tests

(MT8852B-043 or option 27 installed units only)

Note

A control cable connection (RS232, USB, 2-Wire, USB->RS232 adapter or USB->2-Wire adapter) is required when performing low energy tests. Refer to section 6.2 for details. USB to serial adapters must be based on FTDI devices. Other chips do not work.

Packet Types

The Bluetooth 5 Specification introduces additional low energy packet types. See [Table 7-17](#).

Packet Type	Description
BLE	Bluetooth Low Energy 1 Mbps packet.
2LE	Bluetooth Low Energy 2 Mbps packet.
BLR8	Bluetooth Low Energy Long Range packet (LE Coded S=8)
BLR2	Bluetooth Low Energy Long Range packet (LE Coded S=2)
BLR	Bluetooth Low Energy Long Range packet, S=8 or S=2.

Table 7-17. Bluetooth Low Energy Packet Types

Tests on 2LE packets require Option 35, and tests on BLR packets require Option 36. The descriptions and illustrations in this section assume that both options are installed.

Output Power Test

The MT8852B transmits a test control message over the RS232, USB, 2-Wire or USB-Adaptor interface instructing the EUT to transmit reference test packets. The MT8852B measures the average power of the received packets over at least 20% to 80% of the duration of the burst.

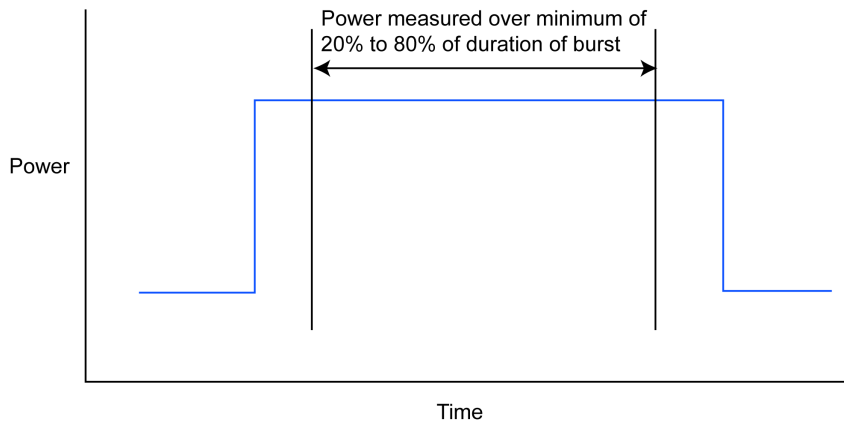

Figure 7-58. Low Energy Output Power Test

The table below details the test conditions and the associated default settings. Permitted variations from the default setting are detailed in the “User Range” column.

Table 7-18. Output Power Test Conditions

Parameter	Default value	User Range
Number of packets	10	1 to 10,000
Packet types	BLE	BLE, 2LE, BLR

Results

1. Position the cursor at "Output power" in the Script menu.
2. Press the [Results] soft key.
3. Press the third soft key (for example [2LE]) to cycle through results for other packet types, if available. The second line of the display shows the packet type for the currently displayed results.

The Output power results page displays.

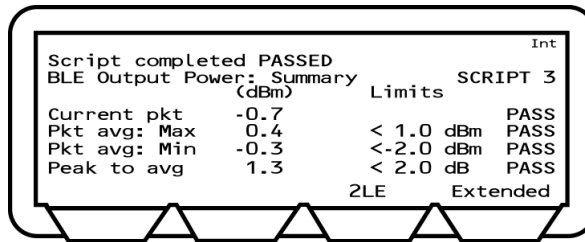

Figure 7-59. Low Energy Output Power Results

- Current pkt:** Displays the average power of the last packet measured by the MT8852B. The MT8852B identifies the p0 in the packet and measures the power in each individual bit. Packet avg is the average power of all the measured bits.
- Pkt avg; Max:** Displays the highest power measured of all of the Packet avg measurements during the test.
- Pkt avg; Min:** Displays the lowest power measured of all of the Packet avg measurements during the test.
- Peak to avg:** This is the dB value of the single bit with the highest power relative to the average power of the packet. “Peak to avg” is sometimes referred to as Crest factor.

- Press the [Extended] soft key to display more detailed test results. Unlike the summary page shown above, the extended pages are specific to each of the test scenarios. If a test is performed at high, medium, and low frequencies, with hopping both on and off, there would be six extended pages. An example of the first extended page for the output power test is shown below.

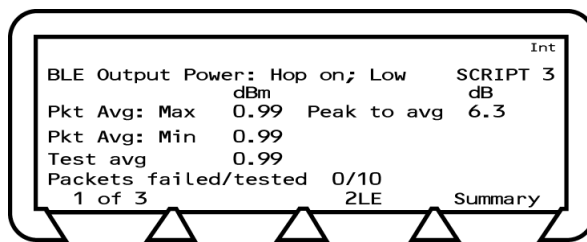

Figure 7-60. Low Energy Output Powers Extended Results

- Page through the extended screens with the soft key in the normal manner, or press the [Summary] soft key to revert to the initial summary page.

Carrier & Drift Test

The carrier drift test performs a frequency drift measurement over the length of the packet received. The carrier frequency offset is measured in the same manner as basic rate initial carrier test, but on the eight preamble bits in the low energy reference packet.

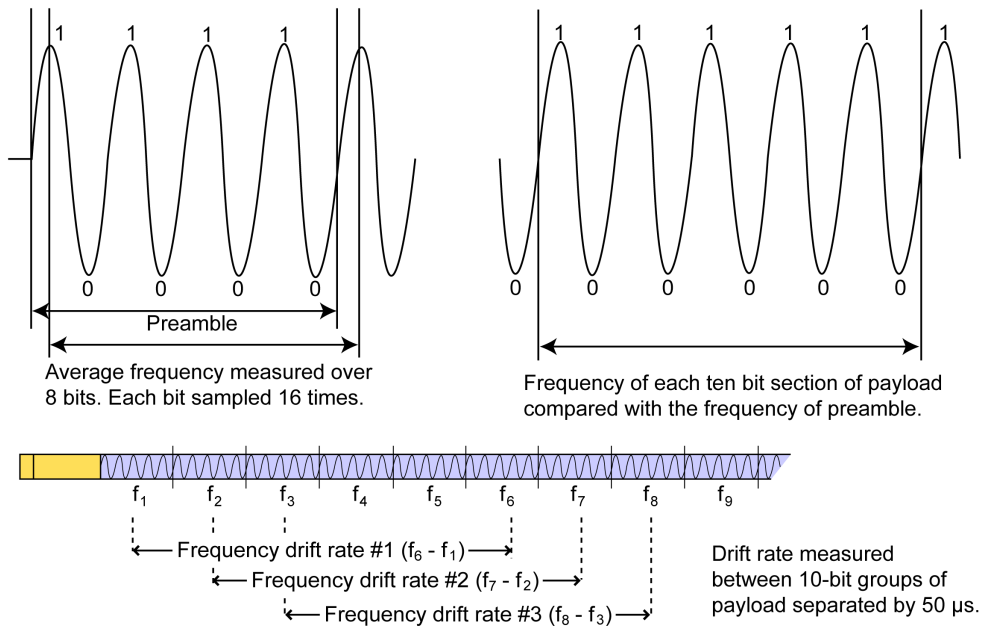

Figure 7-61. Low Energy Carrier & Drift Test - BLE Packets

There are differences in the measurement method for 2LE packets because of the 2 Mbps data rate, and for BLR (S=8) packets because the encoding method used is not capable of generating a 10101010 pattern.

When measuring 2LE packets, the maximum drift rate applies to the difference between any two 20-bit groups separated by 50 μs (BLE uses 10-bit groups).

When measuring BLR (S=8) packets, the payload type used for testing consists of a repetitive sequence of '11111111' octets. When passed through the S=8 encoder, this sequence becomes a repeating '00111100' pattern. The measurement is carried out as follows:

From the start of the preamble field the average frequency is measured in groups of 16 bits. A similar process is carried out throughout the payload of the packet. The instrument then checks the drift rate over any 48 μs interval in the payload and also the drift rate over two specified 48 μs intervals in the preamble.

Note In 2015 the Bluetooth Test Specification was amended to relax the drift rate test limit for the drift measured between the preamble and the first ten bit section of the payload. MT8852B firmware version 4.20.007 and later incorporate this change and describe this measurement as the Initial Drift Rate.

The table below details the test conditions and the associated default settings. Permitted variations from the default setting are detailed in the “User Range” column.

Table 7-19. Carrier Drift Test Conditions

Parameter	Default value	User Range
Number of packets	10	1 to 10,000
Packet type	BLE	BLE, 2LE, BLR8

Results

1. Position the cursor at "Carrier drift" in the Script menu.
2. Press the [Results] soft key.

The Carrier drift results page displays.

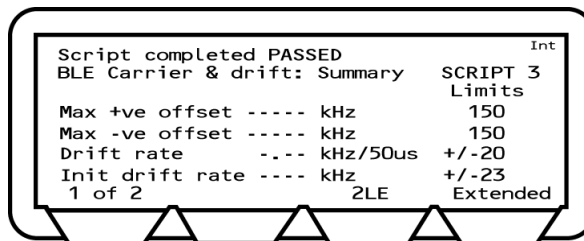

Figure 7-62. Low Energy Carrier Drift Results - Screen 1



Figure 7-63. Low Energy Carrier Drift Results - Screen 2

Max +ve offset: Displays the frequency error of the single packet that had the greatest positive error of all those measured.

- Max -ve offset: Displays the frequency error of the single packet that had the greatest negative error of all those measured.
- Drift rate: Displays the maximum drift rate between any two 10-bit groups in the packet, separated by 50 us. This value is the peak held worst-case value for packets measured during the test.
- Init drift rate: Displays the drift rate between the average frequency of the 8 preamble bits of the packet and the average frequency of the first 10-bit group in the payload. This value is the peak held worst-case value for packets measured during the test.
- Drift: Displays the difference between the average frequency of the 8 preamble bits of the packet and the average frequency of any 10 bits in the payload field of the same packet. This value is the peak held worst-case value for packets measured during the test.
3. Press the [Extended] soft key to display more detailed test results. An example of the first extended page for the carrier drift test is shown below.

```

Script completed PASSED                               Int
BLE Carrier & drift: Low                            SCRIPT 3
Max +ve ----- Drift rate ---- kHz/50us
Max -ve ----- Max drift ---- kHz
Average ----- Avg drift ---- kHz
Init drift rate ---- kHz
Packets failed/tested -----/-----
1 of 3                               2LE Summary

```

Figure 7-64. Low Energy Carrier Drift Extended Results

Note “Packets Tested” refers to the total of all packets tested.

4. Page through the extended screens with the soft key in the normal manner, or press the [Summary] soft key to revert to the initial summary page.

Modulation Characteristics Test

This test measures the modulation characteristics on the EUT output for each of the selected frequency ranges (LOW, MEDIUM and HIGH).

Bluetooth 5 introduces the concept of Stable Modulation Index. A transmitter meeting the stable modulation index standard has a modulation index between 0.495 and 0.505. A device that does not meet this requirement, but otherwise conforms to the low energy test specification is said to have a standard modulation index. The MT8852B now has a test mode setting which allows the choice of testing against either the standard or stable limits, or both.

For modulation tests on BLE and 2LE packet types the MT8852B transmits a test control message over the RS232, USB, 2-Wire or USB-Adapter interface instructing the EUT to transmit reference test packets with a four ones four zeros payload (11110000). For BLR8

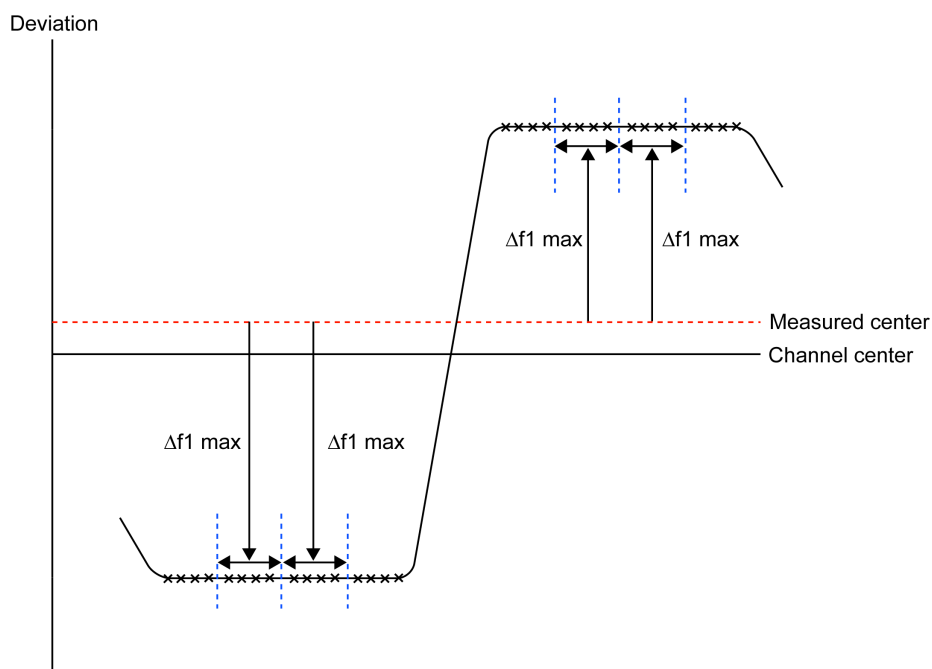

Figure 7-65. Low Energy Modulation Index Test (11110000)

packets, the EUT is instructed to transmit a bit stream which, when encoded by the forward error correction function and the pattern mapper, produces a payload with a similar repeating four ones, four zeros pattern. Modulation characteristics tests are not required for BLR2 packets.

The MT8852B calculates the average frequency of each 11110000 payload section. It measures the deviation from the average frequency for bits 2, 3, 6, and 7. These values are called $\Delta f1$ max values.

Next, for BLE and 2LE packet types, the MT8852B transmits a test control message instructing the EUT to transmit reference test packets with an alternate ones and zeros payload (10101010). This measurement is omitted when testing BLR8 packets because the

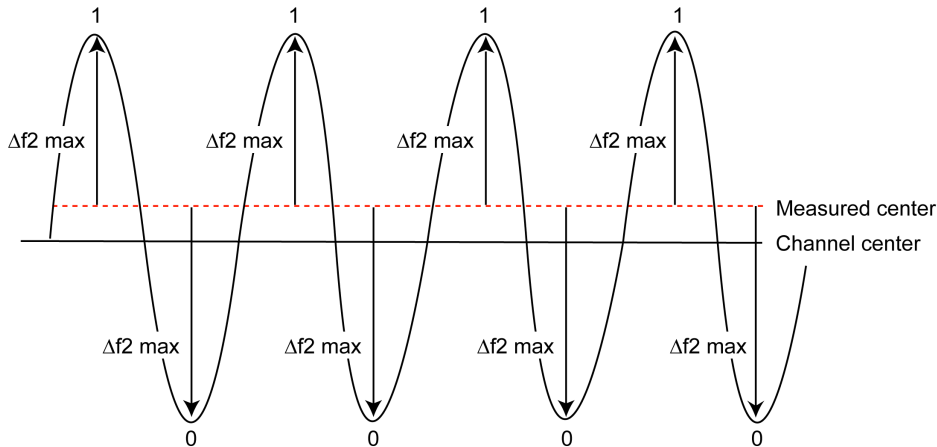

Figure 7-66. Low Energy Modulation Index Test (10101010)

coding scheme used cannot generate this pattern.

The MT8852B calculates the average frequency of each 10101010 8-bit payload section. Then it measures the deviation from the average frequency values for all 8-bit sections. These values are called $\Delta f2 \text{ max}$ values.

This test is performed with hopping off, and the test is repeated until the number of packets has been measured on each of the selected frequencies as set in the "Number of packets" field.

The table below details the test conditions and the associated default settings. Permitted variations from the default setting are detailed in the "User Range" column.

Table 7-20. Modulation Index Test Conditions

Parameter	Default value	User Range
Number of packets	10	1 to 10,000
Toggle payload	Once	Once, Continuous
Packet type	BLE	BLE, 2LE, BLR8
Test mode	Standard	Standard, Stable, Standard + Stable

Results

1. Position the cursor at "Modulation index" in the Script menu.
2. Press the [Results] soft key.

The results page displays.

```

Script completed PASSED                               Int
BLE Modulation index: Results  SCRIPT 3
          kHz                Limits
f1 avg    ---- 225  <= f1 <= 275
f2 avg    ----
f2 max    ----                >= 185
f2avg/f1avg ----                >= 0.8
                                     2LE  Extended
  
```

Figure 7-67. Low Energy Modulation Index Results

- F1 avg:** The MT8852B measures the maximum deviation for the second, third, sixth and seventh bit of each 11110000 payload byte. It then calculates the average value of all these deviations for each packet. This value is recorded as F1avg for each packet. The displayed value on the MT8852B is the highest F1 avg value of all the packets that have been measured.
- F2 avg:** The MT8852B measures the maximum deviation of each 10101010 bit in the payload. The average of all these maximum deviations is then calculated and recorded as F2avg.
- F2 max:** The MT8852B measures the maximum deviation of each 10101010 bit in the payload. Each of these values is recorded as an F2max value. The displayed value of F2max is the single bit measured in a test that has the lowest recorded deviation. The percentage of F2max values that are greater than the limit of 185 kHz is also displayed. The pass/fail criteria is made relative to the percentage value passed, and should exceed 99.9%.

Note Pattern errors found in either the 11110000 or 10101010 payload are discarded.

- Press the [Extended] soft key to display more detailed test results. An example of the first extended page for the modulation index test is shown below.

```

Script completed PASSED                               Int
BLE Modulation index: Low  SCRIPT 3
          kHz                kHz
f1 avg    ----  f2 avg    ----
f1 max    ----  f2 max    ----
f2avg/f1avg ----  f2 pass % ----
Packets Failed/Tested ----/----
1 of 3                2LE  Summary
  
```

Figure 7-68. Low Energy Modulation Index Extended Results

4. Page through the extended screens with the soft key in the normal manner, or press the [Summary] soft key to revert to the initial summary page.

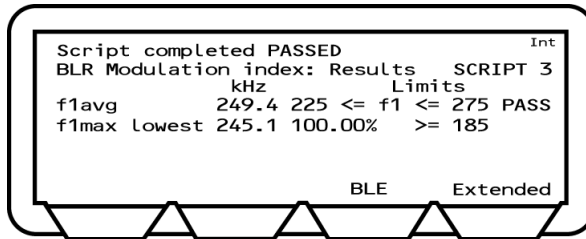

Figure 7-69. Low Energy Modulation Index Results for BLR S=8 Packets

Modulation characteristics results for Long Range packets (BLR S=8) are different from those of BLE and 2LE.

Note

For this coding scheme, 10101010 patterns never appear in the payload, and it is not possible to measure F2 average and F2 max. However, 11111111 data, when passed through the S=8 encoder, becomes a repeating 00111100 pattern, which is used to measure F1 average as before, and 'F1 max lowest' (worst case) instead of F2 max.

Modulation characteristics measurements are not required for BLR S=2 signals.

Sensitivity Test

After sending a test control to prepare the EUT, the MT8852B sends BLE reference packets to the EUT. The number of packets received at the EUT is counted and this data is then read by the MT8852B over the HCI or 2-Wire connection.

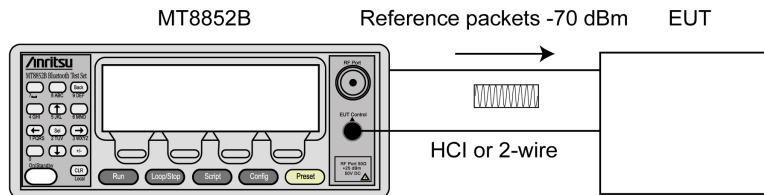

Figure 7-70. Low Energy Sensitivity Test

The table below details the test conditions and the associated default settings. Permitted variations from the default setting are detailed in the “User Range” column.

Table 7-21. Sensitivity Test Conditions

Parameter	Default value	User Range
Number of packets	1500 (440000 bits)	1 to 10,000
Test Tx power	-70.0 dBm	-90.0 dBm to 0.0 dBm
Dirty transmitter	ON	OFF, ON
Packet type	BLE	BLE, 2LE, BLR2, BLR8

Results

1. Position the cursor at "Sensitivity" in the Script menu.
2. Press the [Results] soft key.

The sensitivity results pages displays.

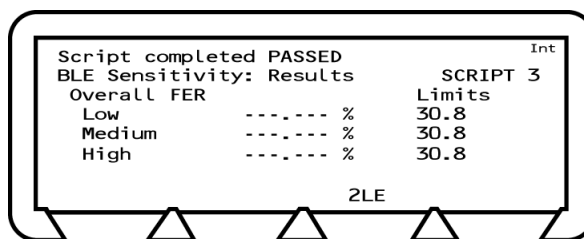

Figure 7-71. Low Energy Sensitivity Results 1

PER Integrity

The MT8852B sends an random even number of BLE reference packets to the EUT at -30 dBm with a PRBS9 payload. The CRC value for the packets is alternated between a valid and invalid value. The EUT counts the number of received packets and this value is read by the MT8852B over the HCI or 2-Wire interface for frame error rate (FER) calculation. The test is repeated three times at the frequency selected.

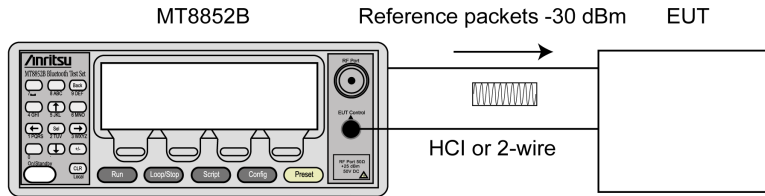

Figure 7-72. Low Energy PER Integrity Test

The table below details the test conditions and the associated default settings. Permitted variations from the default setting are detailed in the “User Range” column.

Table 7-22. PER Integrity Test Conditions

Parameter	Default value	User Range
Number of packets	Random	Random, Fixed (user defined)
Test Tx power	-30.0 dBm	-90.0 dBm to 0.0 dBm
Frequency	2440 MHz	(same as Low/Medium/High settings)
Cycles	3	1 to 5
Packet types	BLE	BLE, 2LE, BLR8, BLR2

Note If “Number of packets” is set to “Fixed”, the specified number of packets must be an even value between 10 and 10,000. An error message displays if an odd value is specified.

Results

1. Position the cursor at "PER Integrity" in the Script menu.
2. Press the [Results] soft key.

The PER integrity results display.

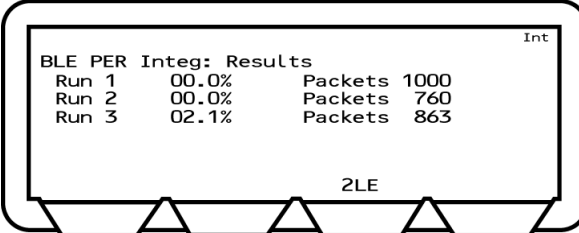

BLE PER	Integ:	Results	
Run 1	00.0%	Packets	1000
Run 2	00.0%	Packets	760
Run 3	02.1%	Packets	863

2LE

Figure 7-73. Low Energy PER Integrity Results

Maximum Input Power Test

After sending a test control, the MT8852B sends BLE reference packets to the EUT at -10 dBm. The number of packets received at the EUT is counted and this data is then read by the MT8852B over the HCI or 2-Wire connection. This test is not required for BLR packets.

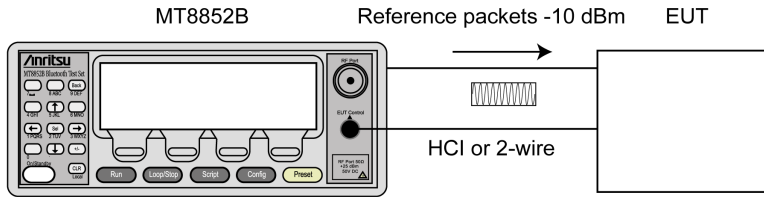

Figure 7-74. Low Energy Maximum Input Power Test

The table below details the test conditions and the associated default settings. Permitted variations from the default setting are detailed in the “User Range” column.

Table 7-23. Maximum Input Power Test Conditions

Parameter	Default value	User Range
Number of packets	1500 (444000 bits)	1 to 10,000
Test tx power	-10.0 dBm	-90.0 dBm to 0.0 dBm
Packet type	BLE	BLE, 2LE

Results

1. Position the cursor at "Max input power" in the Script menu.
2. Press the [Results] soft key.

The Maximum input power results page displays.

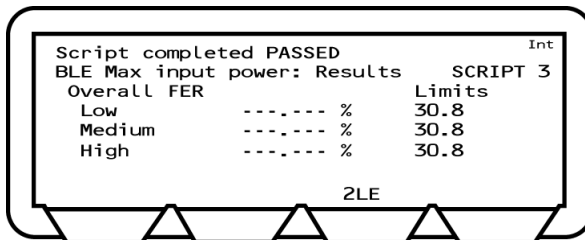

Figure 7-75. Low Energy Max Input Power Results

Chapter 8 — Running a Script in Single Payload Mode

8-1 Single Payload Mode (Not available on MT8852B-043)

Single payload mode uses only a restricted form of test mode signalling. This mode is ideal for use with EUTs that do not support full test mode signalling and which may experience problems if standard mode were used.

The MT8852B sends a single test control to put the EUT into the user-defined state and no further test controls are used.

When single payload mode is selected, a message to this effect displays on the uppermost line of every page.

8-2 Supported Tests

The table below lists the tests that are supported in single payload mode for each of the *Bluetooth* test types.

Table 8-1. Tests Supported in Single Payload Mode

Basic Rate Tests	Enhanced Data Rate Tests	Low Energy Tests
Output Power	EDR tests are not supported in single payload mode	Low energy test are not supported in single payload mode
Init carrier		
Carrier drift		
Single sensitivity		
Multi sensitivity		
Modulation index		

8-3 Testing in Single Payload Mode

In single payload mode, the user can define the packet length and payload, select loopback or TX mode, and turn hopping and dirty modes on or off.

1. Press **Script** to display the script entry page.
2. Move the cursor to the script number and press the [Setup] soft key to display the setup pages.
3. Move the cursor to "Script mode" and press **Sel** to toggle the script mode setting to "SINGLE PAYLOAD".
4. Press **↓** to move the cursor to "edit" and press **Sel** to display the test conditions.

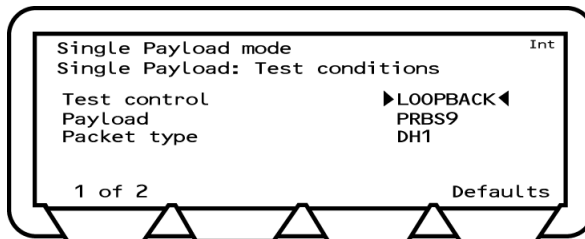

Figure 8-1. Single Payload Mode Test Conditions

5. Make the required settings and press [1 of 2] to display page 2. Refer to Appendix B for definitions of each item.

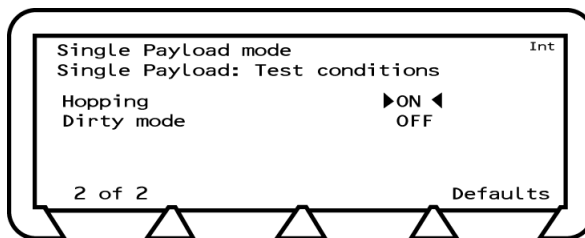

Figure 8-2.

6. Press **Run** to run the script once, or press **Loop/Stop** to run the test script in accordance with the instrument-wide script parameters outlined in chapter 5.

On pressing run, the MT8852B sends a single test control to the EUT to trigger it to transmit the packets defined under the single payload test conditions.

7. If required, press the [Abort] soft key to terminate the script immediately. Press **Loop/Stop** again to stop a continuous script.
8. Press the [Results] soft key to view the test results.

8-4 Test Conditions

The RF measurements that can be performed are dependent on the packet type that has been configured in single payload mode. For example, a carrier drift measurement can be performed only if a 10101010 has been selected. This information is presented in the table below. A shaded cell indicates that the test can be run at any setting.

Table 8-2. Tests Supported in Single Payload Mode

	Test control	Payload	Packet type	Hopping	Dirty mode
Output Power					Off
Init carrier					Off
Carrier drift		10101010			Off
Single sensitivity	Loopback	PRBS9	DH1		
Multi sensitivity	Loopback	PRBS9	DH3 or DH5		
Modulation index		101010101 or 11110000		Off	Off

8-5 Results

The results are a subset of those detailed in chapter 7.

All results are fully compliant with the RF test specification.

Chapter 9 — Running a Script in Null Packet Mode

9-1 Null Payload Mode (Not available on MT8852B-043)

Null packet mode is used to enable indicative measurements to be made on EUTs that do not support test mode. The MT8852B connects to the EUT and maintains the link by sending Poll packets. The EUT returns Null packets containing preamble, access code, trailer, and header, but no payload.

Note

In Null packet mode the MT8852B does not use test mode signalling and tests are not performed in accordance with the *Bluetooth* test specification.

When Null packet mode is selected, a message to this effect displays on the uppermost line of every screen.

9-2 Supported Tests

The table below lists the tests that are supported in Null packet mode for each of the *Bluetooth* test types.

Table 9-1. Tests Supported in Null Packet Mode

Basic Rate Tests	Enhanced Data Rate Tests	Low Energy Tests
Output Power	EDR tests are not supported in null packet mode	Low energy tests are not supported in null packet mode
Power control		
Init carrier		
Carrier drift		
Modulation index		

9-3 Testing in Null Packet Mode

1. Press **Script** to display the script entry page.
2. Move the cursor to the script number and press the [Setup] soft key to display the setup pages.
3. Move the cursor to "Script mode" and press **Sel** to toggle the script mode setting to "NULL PACKET".

Output Power Test

The MT8852B transmits a Poll packet to the EUT. The EUT responds by sending a Null packet to the MT8852B at its maximum output power. The received power of the Null packet is measured by the MT8852B.

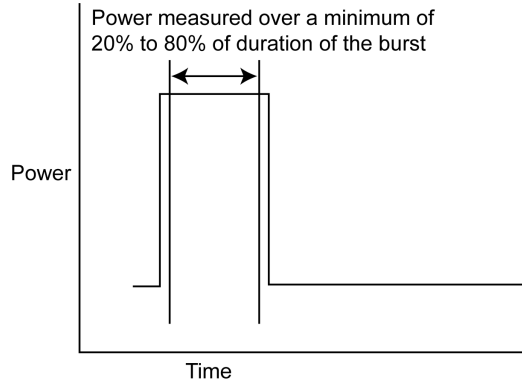

Figure 9-1. Output Power Test

The table below details the test conditions and the associated default settings. Permitted variations from the default setting are detailed in the “User Range” column.

Table 9-2. Output Power Test Conditions

Parameter	Default value	User Range
Hopping test mode	Defined	Defined, All, Any
Number of packets	10	1 to 10,000

Results

1. Position the cursor at "Output power" in the Script menu.
2. Press the [Results] soft key.

The Output power results page displays.

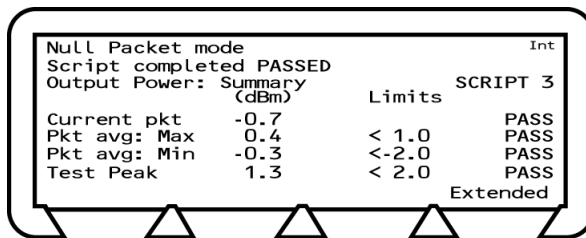

Figure 9-2. Output Power Results

- Current pkt:** Displays the average power of the last packet measured by the MT8852B. The MT8852B identifies the position of the first bit (p0) in the packet and measures the power in each individual bit. Packet avg is the average power of all the measured bits.
- Pkt Avg; Max:** Displays the highest power measured of all of the Packet avg measurements during the test.
- Pkt Avg; Min:** Displays the lowest power measured of all of the Packet avg measurements during the test.
- Test peak:** This is the power of the single bit in the packet that has the greatest power. The value displayed is the largest peak power measured for all packets in the test.

3. Press the [Extended] soft key to display more detailed test results. Unlike the summary page shown above, the extended pages are specific to each of the test scenarios. If a test is performed at high, medium, and low frequencies, with hopping both on and off, there would be six extended pages. An example of the first extended page for the output power test is shown below.

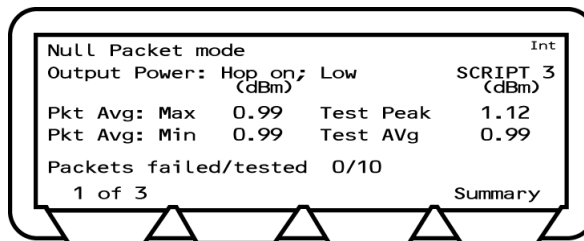

Figure 9-3. Output Powers Extended Results

4. Page through the extended screens with the soft key in the normal manner, or press the [Summary] soft key to revert to the initial summary page.

Power Control Test

A power measurement cycle sets the EUT output power to its maximum, steps it down to the minimum, and then back to the maximum, one step at a time. For each power step a number of Poll packets are sent to the EUT which responds by sending Null packets back to the MT8852B.

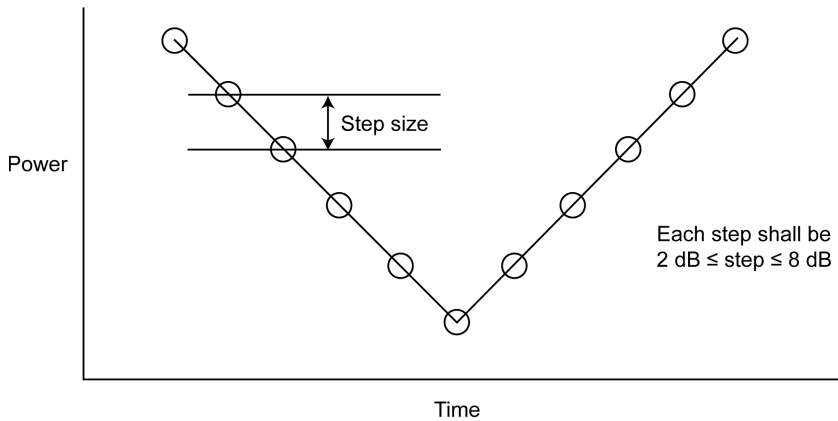

Figure 9-4. Power Control Test

The table below details the test conditions and the associated default settings. Permitted variations from the default setting are detailed in the “User Range” column.

Table 9-3. Power Control Test Conditions

Parameter	Default value	User Range
Cycles	1	
Packets per step	1	1 to 10,000
Minimum test power	-35 dBm	-40 dBm to 0,0 dBm
Measurement delay	0.1 s	0.1 s to 100 s

Results

1. Position the Cursor at "Power control" in the Script menu.
2. Press the [Results] soft key.

The Power control results page displays.

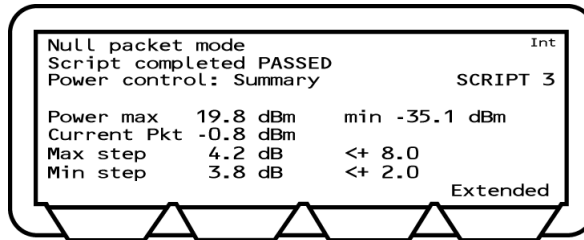

Figure 9-5. Power Control Results

- Power max: Displays the maximum power that the EUT reached in the test.
 - Power min: Displays the minimum power the EUT reached in the test.
 - Current Pkt: Displays the average power of the last packet measured by the MT8852B. The MT8852B identifies the position of the first bit (p0) in the packet and measures the power in each individual bit. Packet avg is the average power of all the measured bits.
 - Max step: Displays the largest change between the power level steps.
 - Min step: Display the smallest change between the power level steps.
3. Press the [Extended] soft key to display more detailed test results. Unlike the summary page shown above, the extended pages are specific to each frequency.

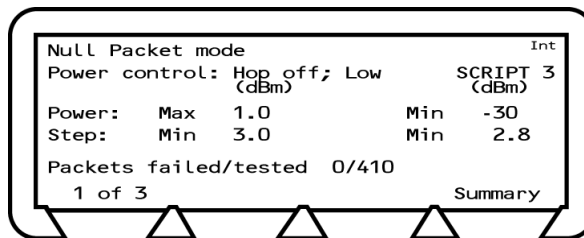

Figure 9-6. Output Powers Extended Results

4. Page through the extended screens with the soft key in the normal manner, or press the [Summary] soft key to revert to the initial summary page.

Initial Carrier Test

The initial carrier test performs a frequency accuracy test on Null packet transmitted from the EUT.

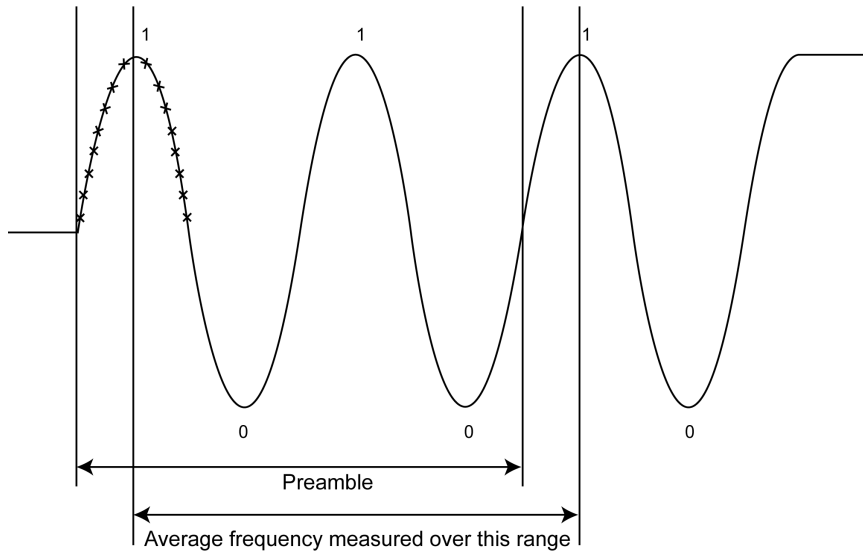

Figure 9-7. Initial Carrier Test

The table below details the test conditions and the associated default settings. Permitted variations from the default setting are detailed in the “User Range” column.

Table 9-4. Initial Carrier Test Conditions

Parameter	Default value	User Range
Hopping test mode	Defined	Defined, All, Any
Number of packets	10	1 to 10,000

Results

1. Position the cursor at "Init carrier" in the Script menu.
2. Press the [Results] soft key.

The Initial carrier results display.

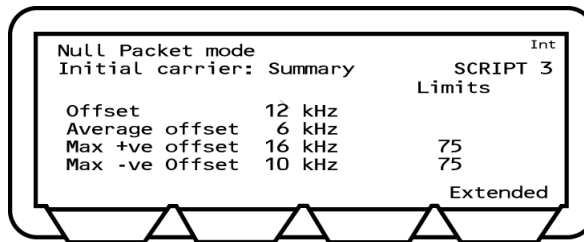

Figure 9-8. Initial Carrier Results

- Offset: Displays the initial frequency error of the last packet measured.
- Average offset: Displays the average value of all initial frequency offset measurements made in the test.
- Max +ve offset: Displays the frequency error of the single packet that had the greatest positive error of all those measured.
- Max -ve offset: Displays the frequency error of the single packet that had the greatest negative error of all those measured.

3. Press the [Extended] soft key to display more detailed test results. Unlike the summary page shown above, the extended pages are specific to each of the test scenarios. For example, if a test is performed at high, medium, and low frequencies, with hopping both on and off, there would be six extended pages. An example of the first extended page for the initial carrier test is shown below.

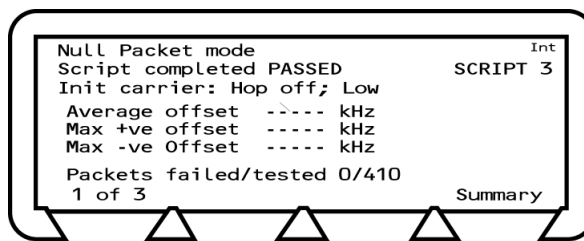

Figure 9-9. Initial Carrier Extended Results

4. Page through the extended screens with the soft key in the normal manner, or press the [Summary] soft key to revert to the initial summary page.

Carrier Drift Test

The carrier drift test performs a frequency drift measurement between two defined sections of the Null packet transmitted by the EUT. The average frequency of the preamble is measured as described for the initial carrier frequency test. This is then compared to the average frequency of the four trailer bits in the Null packet.

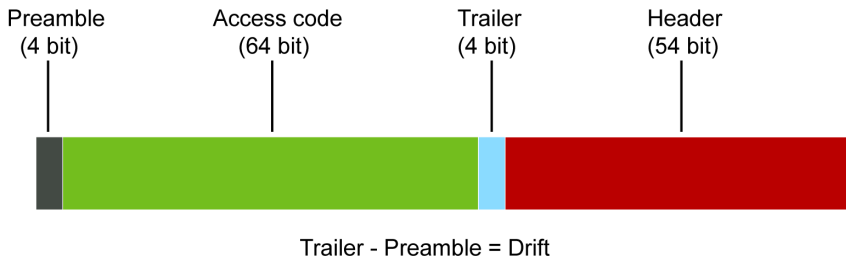

Figure 9-10. Carrier Drift Test

The table below details the test conditions and the associated default settings. Permitted variations from the default setting are detailed in the “User Range” column.

Table 9-5. Carrier Drift Test Conditions

Parameter	Default value	User Range
Hopping test mode	Defined	Defined, All, Any
Number of packets	10	1 to 10,000

Results

Standard and single packet modes

1. Position the cursor at "Carrier drift" in the Script menu.
2. Press the [Results] soft key.

The Carrier drift results page displays.

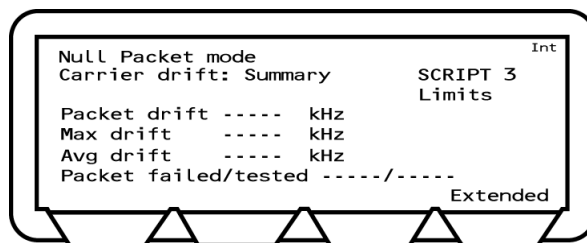

Figure 9-11. Carrier Drift Results

3. Press the [Extended] soft key to display more detailed test results. An example of the first extended page for the carrier drift test is shown below.

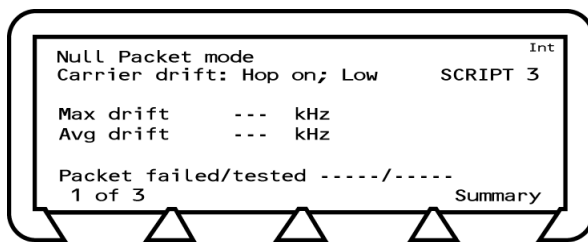

Figure 9-12. Carrier Drift Extended Results

4. Page through the extended screens with the soft key in the normal manner, or press the [Summary] soft key to revert to the initial summary page.

Modulation Index Test

This test measures the modulation characteristics on the EUT output for each of the selected frequency ranges (LOW, MEDIUM and HIGH).

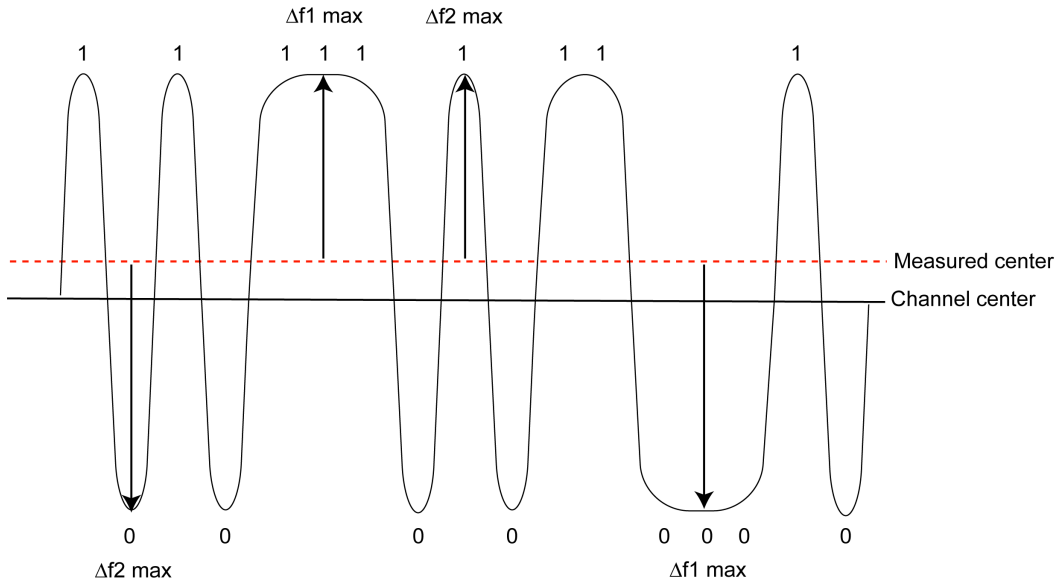

Figure 9-13. Modulation Index Test

The Null packet is analyzed and measurements are made when a suitable wave pattern is identified. Delta f2 max is calculated when a 010 or 101 bit pattern is identified. Delta f1 max is calculated when a 111 or 000 bit pattern is identified.

The test is repeated until the number of packets has been measured on each of the selected frequencies as set in the "Number of packets" field.

The table below details the test conditions and the associated default settings. Permitted variations from the default setting are detailed in the "User Range" column.

Table 9-6. Modulation Index Test Conditions

Parameter	Default value	User Range
Number of packets	10	1 to 10,000

Results

1. Position the cursor at "Modulation index" in the Script menu.
2. Press the [Results] soft key.
The results page displays.

Null Packet mode		Results		SCRIPT 3	Int
Modulation index: (kHz)		Limits			
f1 avg	168.2	140<=f1<=175	PASS		
f2 avg	154.8				
f2 max	122.6	100.00%>=155	PASS		
f2avg/f1avg	0.83	>=0.8	PASS		
				Extended	

Figure 9-14. Modulation Index Results

- F1 avg: The average value of all f1 deviations for the packet. The displayed value on the MT8852B is the highest F1 avg value of all the packets that have been measured.
- F2 avg: The average value of all f2 deviations for the packet. The displayed value on the MT8852B is the highest F1 avg value of all the packets that have been measured.
- F2 max: The displayed value of F2max is the single bit measured in a test that has the lowest recorded deviation. The percentage of F2max values that are greater than the limit of 115 kHz is also displayed. The pass/fail criteria is made relative to the percentage value passed, and should exceed 99.9%.
3. Press the [Extended] soft key to display more detailed test results. An example of the first extended page for the modulation index test is shown below.

Null Packet mode		Hop off; Low		SCRIPT 3	Int
Modulation idx: (kHz)		(kHz)			
f1 avg	154.4	f2 avg	139.1		
f1 max	156.6	f2 max	134.4		
f2avg/f1avg	0.90	f2 pass%	100.00		
Packets Failed/Tested		0/20			
1 of 3				Summary	

Figure 9-15. Modulation Index Extended Results

4. Page through the extended screens with the soft key in the normal manner, or press the [Summary] soft key to revert to the initial summary page.

Chapter 10 — Running a Single Test

10-1 Running a Single Test

Tests can be selected and run individually if it is not necessary or desirable to run an entire test script. The user can decide whether or not any changes made to the test conditions and limits are saved to the script.

1. Configure the EUT address settings as required (as outlined earlier in chapter 6).
2. Press **Script**.
3. Use the arrow keys to position the cursor at the required test group and press [Setup].
4. Use the arrow keys to position the cursor at the test to be run and press [Single].
A summary page, such as that shown below, displays for the selected test.

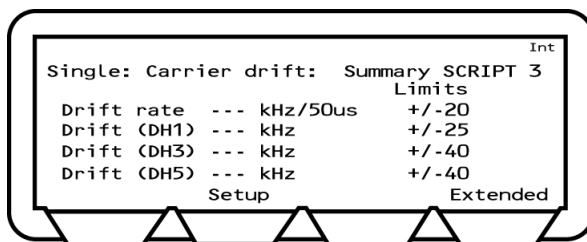

Figure 10-1. Carrier Drift Results

5. Press the [Setup] soft key to display the test conditions for the selected measurement.

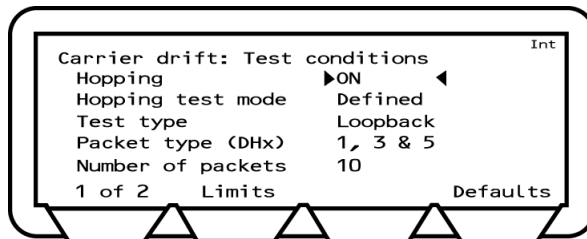



Figure 10-2. Carrier Drift Test Conditions

6. With the cursor on the uppermost test condition, press the **Sel** key to toggle through the available settings for that item.



7. Use the  key to navigate to any test conditions that require changing. Press the  key to toggle the settings or to enable entry of a new value.

Note Refer to Appendix B for an alphabetic listing of all test conditions and their meanings.

Note Changes made to the test conditions are not automatically carried over to the settings in the selected script. When the user returns to the Script or Config pages, a message displays asking whether the changes should be saved to the script.

8. Press the [Limits] soft key to display the test limits for the selected test. The limits are set by default to match the requirements set out in the *Bluetooth* specification.

Note Changes made to the limits are not automatically carried over to the settings in the selected script. When the user returns to the Script or Config pages, a message displays asking whether the changes should be saved into the script.

9. Press the [Save] soft key to save the test conditions.
10. Press  to run the script once, or press  to run the test script in accordance with the instrument-wide script settings outlined in chapter 5.
11. If required, press the [Abort] soft key to terminate the script immediately. Press  again to stop a continuous script.
12. The test results display.

Chapter 11 — Configuration Reference

This chapter provides a glossary style reference to all items found within the **Config** menu.

Items are detailed in the order in which they appear on the MT8852B. The table below may be useful in locating the required information.

Users viewing this document electronically can click on the page reference to jump to the appropriate section.

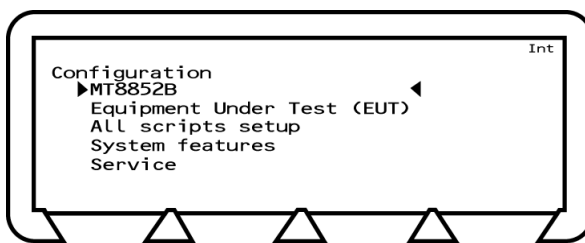

Figure 11-1. Configuration Menu

11-1 Navigation Table

Table 11-1. MT8852B Configuration Table

MT8852B	Identity	BT address	on page 11-5
		Name	
		Serial no	
		Version	
		Core boot	
		Core code	
		Core FPGA	
		RF FPGA	
		DSP	
		RF pcb serial no	
		RF pcb revision	
		Control pcb serial no	
		Control pcb revision	
		System Interface	
RS232 baud rate			
RS232 mode			
RS232 parity			
RS232 data length			
RS232 stop			
Display and Sound	Display and Sound	Display contrast	on page 11-6
		Key click	
		Entry error beep	
		User text display	
		Enter user text	
		Follow test	
Rx/Tx Settings	Rx/Tx Settings	Range	on page 11-8
		FSK Modulation index	
		Link timeout	
		FSK Bandwidth Filter	
CW measurement	CW measurement	Gate width	on page 11-9
		Channel frequency	

Table 11-1. MT8852B Configuration Table

MT8852B Cont.	Audio	ACL connect status	on page 11-9
		SCO channel status	
		Packet type	
		Air code format	
		SCO loopback	
		Tone generator	
		AFH	
		EUT rep. rate	
		Input coding format	
		Input data format	
		Input sample size	
		Linear PCM bit posn	
		Rear Panel Output	
BNC Output 2			
Signal Generator	Pattern	on page 11-11	
	RF power		
	Channel frequency		
	Modulation index		
BLE packet generator	Sig Gen Pwr level	on page 11-11	
	Pattern		
	Freq		
	Power		
AFH Measurement	SyncWord	on page 11-13	
	ACL Status		
Equipment under Test	View user friendly name	EUT Reporting	on page 11-14
		EUT address	
	View supported features	EUT user friendly name	on page 11-14
		EUT supported features	
	EUT RS232 setup	Baud rate	on page 11-15
		Parity	
		Data length	
		Stop bits	
	Handshaking		

Table 11-1. MT8852B Configuration Table

Equipment under Test cont.	Inquiry/Paging setup	End inquiry after	on page 11-15
		End paging after	
		Read name on inq	
		Page scan rep mode	
	Authentication setup	Authentication	on page 11-16
		PIN Length	
PIN Code			
All Scripts Setup	Loop stop on test fail	on page 11-18	
	Loop Continuous		
	Loop count		
	Display frequency as		
System features	Connection control	ACL connection & features	on page 11-19
		Connection packet control	
		Disconnect from EUT	
		Make me an EUT	
		Inquiry scan is OFF/ON	
	EUT Remote power control	Increment EUT power	on page 11-20
		Decrement EUT power	
		Set EUT power to maximum	
		Set EUT power to minimum	
	Software update	Bootload	on page 11-20
	Feature control	Option number	on page 11-21
Option enable code			
Service		on page 11-23	

11-2 Configuring the MT8852B

Identity

Press **Config** > “MT8852B” > “Identity”

This menu allows the user to display MT8852B *Bluetooth* address, name, serial number, and software versions. Press the [1 of 3], [2 of 3] soft keys to page through the available information as listed in table 11-1.

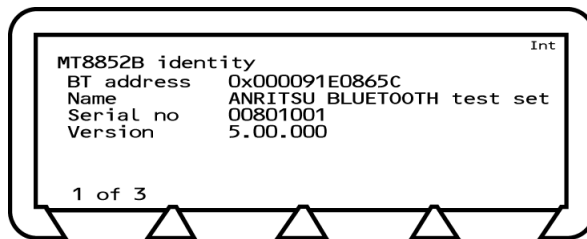

Figure 11-2. MT8852B Identity

System Interface

Press **Config** > “MT8852B” > “System interfaces”

The MT8852B can be controlled remotely from a PC by use of the GPIB or RS232 serial connecting ports on the rear of the instrument. This menu configures the settings of these two interfaces.

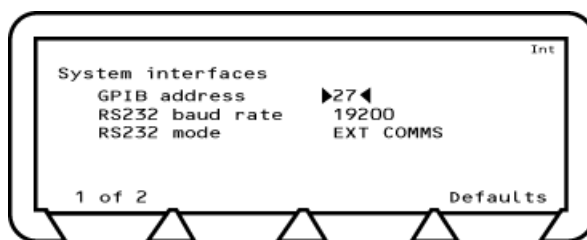

Figure 11-3. System Interfaces 1

GPIB address: The address used by the remote computer to communicate with the MT8852B.

RS232 baud rate: When the MT8852B is controlled using the RS232 interface from a remote computer, the baud rate setting of the MT8852B must match the setting of the PC. Available rates are; 1200, 2400, 4800, 9600, 19200, 38400, and 57600.

RS232 mode: For normal operation the RS232 mode must be set to EXT COMMS. When an external computer is being used to interface to the MT8852B baseband through the rear panel system RS232 interface, then RS232 mode must be set to EXT HCI. In this setting, the MT8852B HCI interface is accessible to a remote computer that can be used to run the layers of *Bluetooth* protocol above HCI.

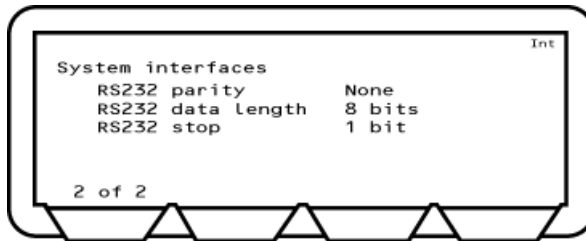

Figure 11-4. System Interfaces 2

RS232 Parity: 0, 1 or None. The default setting is “None”.

RS232 Data length: 7 or 8 bits. The default setting is 8.

RS232 Stop: 1 or 2 bits. The default setting is 1.

Display and Sound

Press **Config** > “MT8852B” > “Display/sound”

This menu allows the user to configure the MT8852B interface as required.

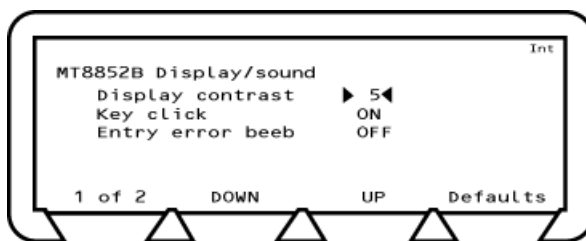

Figure 11-5. MT8852B Display/Sound 1

Display contrast: The display contrast reduces or increases the lighting to the display in the range of 1 (light) to 10 (dark).

Key Click: When set to ON, the instrument makes a clicking sound each time a key is pressed.

Entry error beep: When set to ON the MT8852B makes a beep when incorrect information is entered from the keypad.

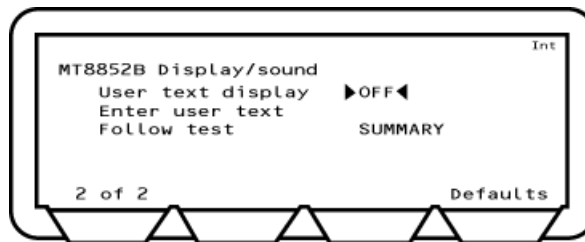

Figure 11-6. MT8852B Display/Sound 2

User text display: Enables entry of user text at “Enter user text”.

Enter user text: Enter up to 15 characters of text to be displayed on the top line of the screen.

Follow test: Set to have either the "SUMMARY" or "EXTENDED" results page display automatically when the tests in the script are running. If "Follow test" is set to "OFF", the results pages must be displayed by the user when the script is complete.

RX/TX Settings

Press **Config** > “MT8852B” > “RX/TX settings”

This menu allows the user to configure the Rx and Tx settings.

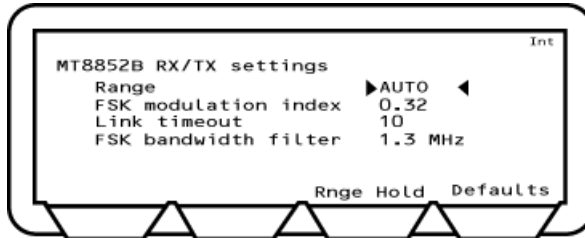

Figure 11-7. MT8852B RX/TX Settings

- Range:** Allows the user to set the MT8852B measuring receiver to a given range.
Auto is the default setting.
RGH1: +22 to +7 dBm.
RGH 2: +9 to -3 dBm.
RGH 3: +5 to -7 dBm.
RGH 4: -4 to -16 dBm.
RGH 5: -12 to -26 dBm.
RGH 6: -24 to -35 dBm.
- FSK modulation index:** The modulation index is the Deviation/Modulation rate. For normal *Bluetooth* operation this should be set to 0.32. To test an EUT under other conditions, the modulation index can be set to other values. The modulation index can be in the range 0.25 to 0.40.
- Link timeout:** This is the Supervision Link Timeout. The MT8852B disconnects from the EUT if it sees no communication from the EUT for the defined period of time. The default value in the *Bluetooth* core specification is 20 seconds, but the default value for the MT8852B is 10 seconds so that the user is aware in a reasonable period of time that the EUT has stopped communicating with the MT8852B.
- FSK bandwidth filter:** The latest *Bluetooth* core specification recommends that the FSK bandwidth of the test instrument is set to 1.3MHz. Early versions of the *Bluetooth* core specification permitted the use of a 2 MHz FSK filter. MT8852B allows the user to select either FSK filter bandwidth, but the 1.3 MHz filter is the recommended and default setting.

CW Measurements

Press **Config** > “MT8852B” > “CW measurement”

This menu allows the user to measure a fixed frequency signal to calibrate power, frequency, and modulation. The CW measurement mode is intended only for the measurement of continuous non-packetized signals; it does not support triggering.

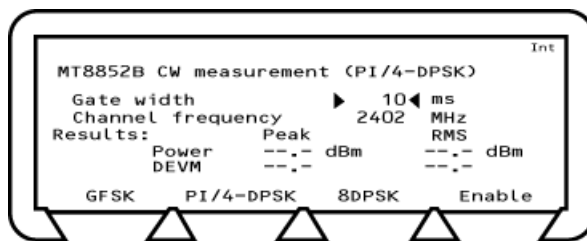

Figure 11-8. MT8852B CW Measurement

Gate width:	Defines the measurement window. Settings can be made between 0.1 ms and the default value of 3 ms.
Channel frequency:	Displays the channel frequency. This item is replaced with “Channel number” if “Display frequency as” is set to “Number” on the “All Script setup” page.
Results:	Displays the power and DEVM results. No results display in the modulation field if the received packet level drops below -40 dBm.
Soft keys:	Sets the modulation of the signal under test. For CW measurements select “GFSK”.

Audio (MT8852B, MT8852B-041 only)

Press **Config** > “MT8852B” > “Audio”

This menu allows users the user to configure audio measurements.

Refer to chapter 14 for a detailed description of audio features.

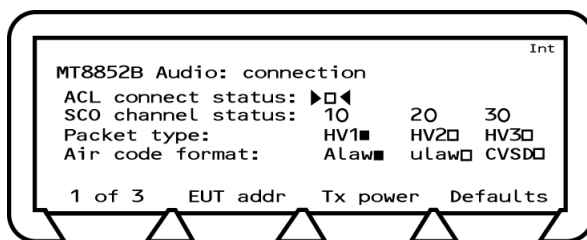

Figure 11-9. MT8852B Audio

Rear Panel Outputs

Press **Config** > “MT8852B” > “Rear panel output”

This menu allows the user to configure the TX and RX signals that are routed to the rear panel BNC connectors.

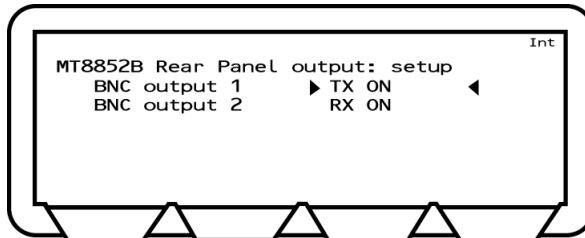

Figure 11-10. MT8852B Rear Panel

- BNC output 1:** The available settings are:
- TX ON:** MT8852B TX on.
 - RX DATA:** MT8852B received data, provides a TTL output of all the received packet bits, including preamble, header and payload.
 - TX DATA:** MT8852B transmitted data, provides a TTL output of all the transmitted packet bits including preamble, header, and payload. TX DATA is only applicable in signal generator mode with GFSK modulation.
 - CORR FIRED:** MT8852B correlator fired, provides a TTL pulse when the MT8852B correlator fires, giving an indication of the flow of good received packets.
- BNC output 2:** The available settings are:
- RXON:** MT8852B RX on.
 - RX DATA:** MT8852B received data, provides a TTL output of all the received packet bits, including preamble, header and payload.
 - TX DATA:** MT8852B transmitted data, provides a TTL output of all the transmitted packet bits including preamble, header, and payload. TX DATA is only applicable in signal generator mode with GFSK modulation.
 - CORR FIRED:** MT8852B correlator fired, provides a TTL pulse when the MT8852B correlator fires, giving an indication of the flow of good received packets.

Note

If Output 1 is TXON, output 2 can be any value. If Output 2 is RXON, output 1 can be any value. Otherwise Output 1 and Output 2 must be set to the same value.

Signal Generator

Press **Config** > “MT8852B” > “Signal generator”

This menu allows the user to define and generate a continuously modulated *Bluetooth* signal. The signal is switched on using the [Enable] soft key and switched off using the [Exit] soft key or **Preset** key.

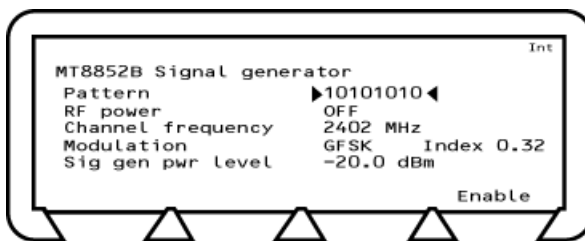

Figure 11-11. MT8852B Signal Generator

- Pattern:** The payload data can be selected from; 10101010, 11110000, PRBS9, PRBS15. If CW is selected, no modulation is applied to the signal output.
- RF power:** Turns the signal generator ON and OFF.
- Channel freq:** Select the channel frequency. This item is replaced with “Channel number” if “Display frequency as” is set to “Number” on the “All Script setup” page.
- Modulation:** Select the modulation pattern.
- Modulation index:** Can be set in the range of 0.2 to 0.4.
- Sig gen pwr level:** Can be set in the range of 0 to -90 dBm.

BLE Pkt Generator

Press **Config** > “MT8852B” > “BLE Pkt generator”

This menu allows the user to generate *Bluetooth* low energy reference packets in accordance with the low energy specification. The signal is switched on using the [Enable] soft key and switched off using the [Exit] soft key or **Preset** key.

Note Path loss compensation settings (table or fixed offset) are not applied to the BLE Packet Generator output.
To compensate for path loss, adjust the Power setting.

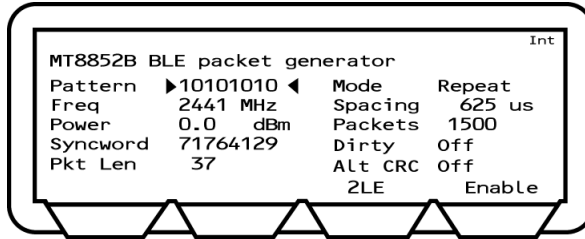

Figure 11-12. BLE Packet Generator

[2LE] This soft key cycles around the available packet types: BLE, 2LE, BLR8 and BLR2, depending on the installed options. The title line at the top of the display shows the type of packet currently being generated.

Pattern: The payload data pattern can be set from; PRBS9, 10101010, 11110000.

Freq: The channel frequency.

Power: Set the power of the signal to be generated.

SyncWord: The *Bluetooth* low energy reference packet synchronization word can be set by the user. The default value is as defined in the *Bluetooth* core specification to 71764129. Many devices can only be tested when the default sync word is used.

Pkt Len: Sets the length of the transmitted packet (option 34). Note the packet length will force the signal generator to comply with the minimum allowed packet spacings shown in the table below.

Data packet length (bytes)	Allowed packet spacing (µs)
2 to 37	625 to 65535
38 to 115	1250 to 65535
116 to 193	1875 to 65535
194 to 255	2500 to 65535

Mode: When set to Count, the number signal generator transmits the number of packets set in the "Packets" field then stops transmitting. When set to "Repeat", the signal generator continuously transmits the number of packets set, resulting in a continuous transmission of the defined packets.

Spacing: The packet repetition rate can be increased from the default *Bluetooth* time slot time of 625 us up to 9999 µs.

Packets: Defines the number of packets that will be sent when the [Start] softkey is pressed and "Mode" is set to "Count".

Dirty: This allows the packets to have the dirty table from the BLE sensitivity test of the selected script applied.

Alt CRC: When set to ON, the MT8852B intentionally corrupts every alternate CRC value. This is used for the BLE packet integrity test.

AFH Measurements (Not Available on MT8852B-043)

Press **Config** > “MT8852B” > “AFH measurements”

This menu allows the user to configure the MT8852B for Adaptive Frequency Hopping measurements (option 15).

Refer to chapter 15 for a detailed description of AFH testing.

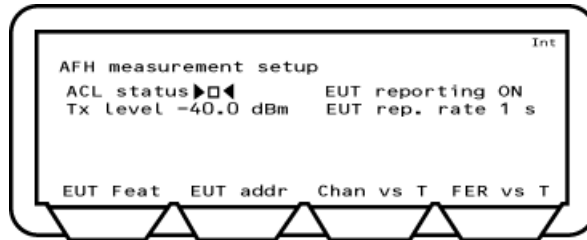

Figure 11-13. AFH Measurement Setup

11-3 Configuring the Equipment Under Test (EUT)

View User Friendly Name

Press **Config** > “Equipment Under Test (EUT)” > “View user friendly name”

Each item of *Bluetooth* equipment has a unique 12 character hexadecimal address. Equipment can also be given a meaningful name. The user-friendly name can be up to 248 characters in length but is truncated on the page at 177 characters.

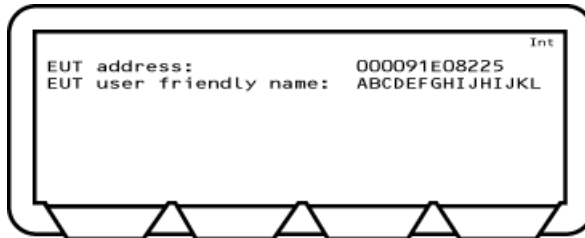

Figure 11-14. EUT Address and User Friendly Name

View Supported Features

Press **Config** > “Equipment Under Test (EUT)” > “View supported features”

This page allows the user to view which optional *Bluetooth* features are supported by the EUT. A solid circle indicates a supported feature; a hollow circle indicates an unsupported feature. Press [1 of 7] to move through the pages in this section.

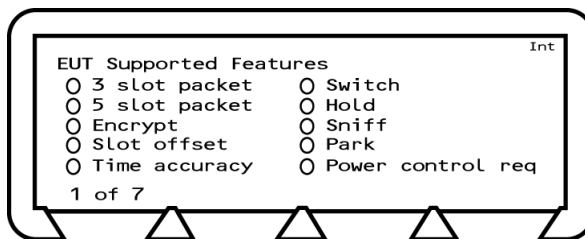

Figure 11-15. EUT Supported Features

EUT RS232 Setup

Press **Config** > “Equipment Under Test (EUT)” > “EUT RS232 setup”

This menu allows the user to configure an RS232 cable connection between the MT8852B and the EUT.

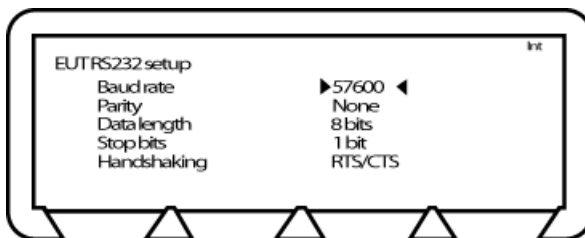

Figure 11-16. EUT RS232 Setup

Baud rate: These settings relate to the RS232 interface of the EUT control port on the front panel of the MT8852B. When interfacing to the EUT HCI using the RS232 interface from the MT8852B, the MT8852B RS232 settings must match those of the EUT. Available HCI RS232 baud rates are; 1200, 240, 4800, 9600, 19200, 38400, 57600, 115200, 230400, 460800, 921600.

Parity: Fixed at “None”.

Data length: Fixed at 8 bits.

Stop bits: Fixed at 1 bit.

Handshaking: RTS/CTS or NONE

Inquiry/Paging Setup

Press **Config** > “Equipment Under Test (EUT)” > “Inquiry/paging setup”

This menu allows the user to configure the conditions under which an inquiry is performed. The inquiry settings made here are used if “Source” (**Script** > [EUT addr]) is set to “Inquiry” to read the *Bluetooth* address directly from the EUT through the radio interface. Refer to chapter 6 for details.

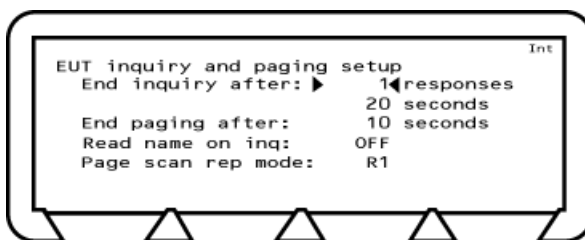

Figure 11-17. EUT Inquiry and Paging Setup

- End inquiry after: Specify the number of inquiry responses to be received before the inquiry is finished.
- If the number of inquiry responses is set to "1", the MT8852B automatically connects to the first device located. Set the number of responses to 1 if the MT8852B is connected directly to the EUT or there is known to be only one EUT that will respond to an inquiry.
- If the response setting is set to a value other than "1" the user must select the required device manually when the inquiry is complete.
- End paging after: Enter the number of seconds for which the MT8852B will page the EUT before timing out. A setting at this item may be required to minimize delay for users who know that a connection will not be established by waiting if unsuccessful after a given number of seconds.
- Read name on inq: Select whether the EUT name is read-in automatically during the inquiry.
- Page scan rep mode: Select either R0, R1, or R2 to match the requirements of the EUT.

Authentication Setup

Press **Config** > "Equipment Under Test (EUT)" > "Authentication setup"

Authentication is the process of configuring a *Bluetooth* unit to connect only to one specified device. A headset, for example, can be configured to connect only to a specific mobile phone, and in this case, verification processing is used to ensure that the correct connections have been established. The MT8852B can be configured to use authentication during the establishment of a connection.

Note The MT8852B does not use authentication by default.

The process of authentication involves creating a common key, referred to as the link key, between the master and slave devices. Security could be compromised if this link key were sent between devices, so instead, it is generated from a random number and a Personal Identification Number (PIN) which can be entered into the MT8852B. If authentication is required but the *Bluetooth* devices do not have a common link key, the authentication procedure is completed using the PIN input, and a link key is then created and stored during the authentication procedure. The link key stored in the *Bluetooth* device can then be used during any future connection.



Figure 11-18. Authentication Setup

Authentication:	When the tester connects to an EUT that requires <i>Bluetooth</i> Authentication and/or encryption, the MT8852B Authentication feature must be enabled.
PIN length:	Authentication requires a PIN number to be exchanged between the tester and the EUT, this PIN number can have a length between 1 and 16 bits.
PIN Code:	This is the actual PIN number, typically 0000.

11-4 Configuring Scripts

All Scripts Setup

Press **Config** > “All scripts setup”

This menu allows the user to configure the parameters that are applied to all scripts. These settings include items to determine if and how measurements are looped. Refer to chapter 5 for complete details of script configuration.

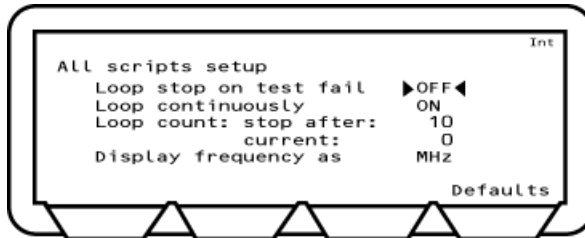

Figure 11-19. All Scripts Setup

- Loop stop on test fail: Select either ON or OFF. If set to “ON” the test is run repeatedly until a failure is recorded or the test is stopped
- Loop continuously: Select either ON or OFF. If set to “ON”, the test is run continuously until stopped by the user.
- Loop count: Enter the number of times that the test will be looped before stopping.
- Display frequency as: Select whether a channel is displayed in number format (0 to 78) or by actual frequency in MHz.

11-5 Configuring System Features

Connection Control

Press **Config** > “System features” > “Connection control”

This menu allows the user to specify how the asynchronous link (ACL) operates.

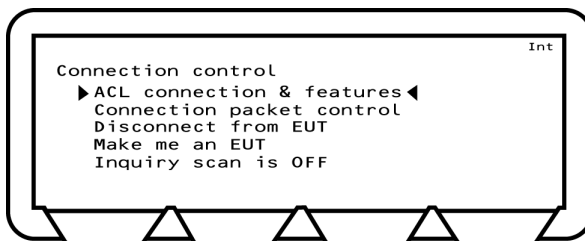

Figure 11-20. Connection Control

- ACL connection & features:** Initiates a baseband connection to the EUT using the currently selected “EUT addr” settings. The EUT features are read but the EUT is not put into test mode. This can be used to verify that a basic connection to the EUT is possible.
- Connection packet control:** Some *Bluetooth* EUTs may not complete standard rate and EDR measurements if the *Bluetooth* connection was established with all packet types enabled. The "Connection packet control" settings can be used to exclude individual packets from the connection process. Testing is still completed with all standard rate and EDR packets selected in the measurement setup pages.
- Disconnect from EUT:** Forces the MT8852B to disconnect from the EUT.
- Make me an EUT:** This setting is used to make the MT8852B behave as the equipment under test. This means that it is page scanning with test mode enabled.
- Inquiry scan is ON/OFF:** The Inquiry feature allows the instrument to respond to an inquiry from another device. This is useful for synchronizing with some *Bluetooth* protocol analyzers. The protocol analyzer can then monitor the messages between the MT8852B and the EUT.

If option 15 (AFH) is enabled, the time taken to establish a connection displays on the top line of the screen. An example of the display is shown below.

Note

Connection made (1: 1054 ms)

The digit prior to the colon represents the number of attempts required to establish the connection. The figure following the colon represents the time in milliseconds taken to establish the connection.

EUT Remote Power Control

Press **Config** > “System features” > “EUT remote power control”

This menu allows the operator to control the EUT power incrimination.

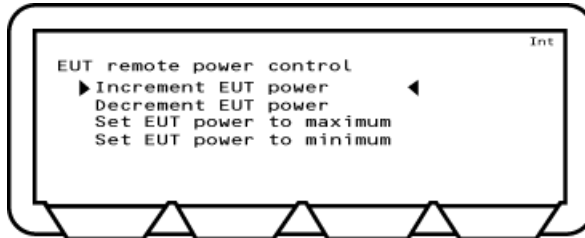

Figure 11-21. EUT Remote Power Control

- | | |
|---------------------------|--|
| Increment EUT power: | Select to increment the EUT power by one increment. |
| Decrement EUT power: | Select to decrement the EUT power by one increment. |
| Set EUT power to maximum: | Select to have the MT8852B continuously send increment power commands until the EUT reports that the maximum power has been reached. |
| Set EUT power to minimum: | Select to have the MT8852B continuously send decrement power commands until the EUT reports that the minimum power has been reached. |

Software Upgrade

Press **Config** > “System features” > “Software update”

This menu allows the operator to upgrade the firmware. Upgrading is performed using the supplied accessory cable to download the software from a PC connected to the MT8852B through the RS232 connector.

Caution

This menu should not be used unless ready to update the software.

If the firmware is not upgraded when “Bootload” is selected, it will be necessary to disconnect the instrument from the power supply.

If the upgrade is interrupted before completion (by the user or by a power failure) the instrument is left in a state from which normal operation cannot be resumed.

Contact your Anritsu Service Center for advice.



Figure 11-22. MT8852B Software Update

The download procedure requires that files be copied from the upgrade disk and a program be run to implement the changes. This procedure is described in the Readme document supplied on the upgrade disk.

Feature Control

Press **Config** > “System features” > “Feature control”

This menu is used to view a list of installed options and to enable (turn on) options or retrofits purchased after the delivery of the instrument.

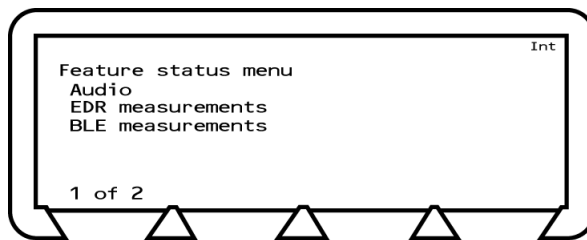

Figure 11-23. Feature Status Menu 1

The options currently installed are displayed on page 1 of 2. The second page (2 of 2) is used to enable further options that have been purchased.

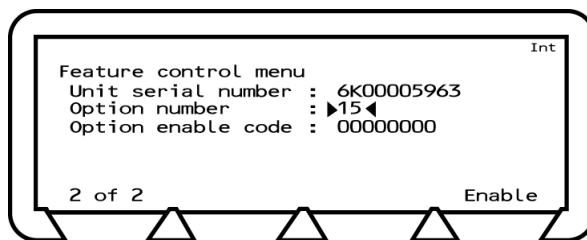

Figure 11-24. Feature Status Menu 2

Unit serial number: Displays the serial number of the MT8852B.

- Option number: Enter the option code number from the numeric keypad and then press the [Enter] key.
- Option enable code: Enter your unique option enabling code number from the numeric keypad and then press the [Enter] soft key. Press the [Enable] soft key to enable the option.

Follow the procedure below to enable an option.

1. Press **Config** > “System features” > “Feature control” > **Sel**.
2. Press the [1 of 2] soft key.
3. Position the Cursor at "Option number" and press **Sel**. Enter the option code number (e.g., 15) from the keypad and press the [Enter] key.
4. Position the cursor at "Option enable code" and press **Sel**. Enter the unique option enabling code number from the keypad and press the [Enter] soft key.
5. Press the [Enable] soft key to enable the option.
6. Press the [2 of 2] soft key to return to the previous page and check that the option is now included in the list of all installed options.

11-6 Service Configuration

Press **Config** > “Service”

This selection is provided for use by qualified service personnel and is password protected. Service procedures are not described in this manual.

Chapter 12 — Signal Generator

12-1 Setting Up the *Bluetooth* Interferer

The MT8852B can be set up to perform the functionality of a *Bluetooth* interferer as defined in the *Bluetooth* RF test specification. This functionality allows the user to reduce overheads by removing the need to purchase expensive digital signal generators.

An interfering *Bluetooth* signal source is required to perform the following test cases:

Note

- Basic Rate C/I performance and Intermodulation performance.
- EDR C/I performance.

1. Press **Config** > "MT8852B" > "Signal generator".

The MT8852B Signal generator page displays.

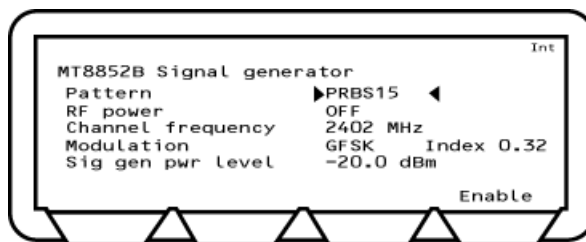

Figure 12-1. MT8852B Signal Generator

2. Move the cursor to "Pattern" and press **Sel** to select the required bit pattern. There are five options available: 1010101010, 11110000, PRBS9, PRBS15, and CW (unmodulated carrier wave).
3. Use the arrow keys to navigate to the other items on the page and make settings as required in the normal manner.
4. Press [Enable] to turn on the signal.
5. Press [Exit] to turn off the signal.

Path loss compensation settings (table or fixed offset) are not applied to the signal generator output.

Note

To compensate for path loss, adjust the signal generator power level setting.

Chapter 13 — CW Measurements

13-1 Performing Continuous Wave Measurement

The MT8852B can measure a fixed frequency signal to calibrate power, frequency, and modulation. The CW measurement mode is intended only for the measurement of continuous non-packetized signals; it does not support triggering.

1. Press **Config** > "MT8852B" > "CW Measurement".

The CW Measurement page displays as shown below.

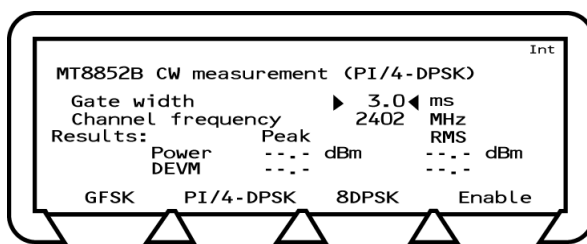

Figure 13-1. MT8852B CW Measurement

2. CW Measurement is commenced using the [Enable] soft key and switched off using the [Exit] soft key or pressing **Preset**.

Gate width: Defines the measurement window. Settings can be made between 0.1 ms and the default setting of 3.0 ms.

Channel frequency: Replaced with "Channel number" depending on the setting that has been made at "Display frequency as" on the All scripts setup page (detailed in the following section of this manual.) The default channel number is 2, with settings possible in the range of -2 to 98.

Note No results display in the modulation field if the received power level drops below -40 dBm.

Chapter 14 — Audio Measurements

The MT8852B and MT8852B-041 *Bluetooth* Test Sets can be used to perform audio measurements by establishing a Synchronous Connection Oriented (SCO) link between the MT8852B and the EUT. A SCO link is a full duplex link between a *Bluetooth* master and slave.

Notes

Audio measurement functionality can be added to any MT8852B, MT8852B-040, MT8852B-041, or MT8852B-042 by purchasing retrofit option MT8852B-319. Audio measurements cannot be performed on the MT8852B-043.

SCO is an optional feature within the *Bluetooth* specification. The MT8852B can be used to establish a SCO link and transmit HV packets to or from the EUT. To perform audio measurements, an audio signal source and audio analyzer are also required (e.g., Keithley 2015).

There are four scenarios in which audio measurements may be made, each of which is illustrated and explained in this chapter. The four test scenarios are:

- Testing the EUT's audio performance using remote loopback on the MT8852B.
- Testing the audio performance of the EUT transmit path.
- Testing the audio performance of the EUT receive path.
- Putting the EUT into remote loopback.

14-1 Testing using Remote Loopback

The EUT's audio performance can be tested using the set-up below. The MT8852B is put into remote loopback and the audio path tested without passing the signal through the MT8852B CODEC. The audio is looped back in the MT8852B baseband and so there is no audio distortion introduced by the tester.

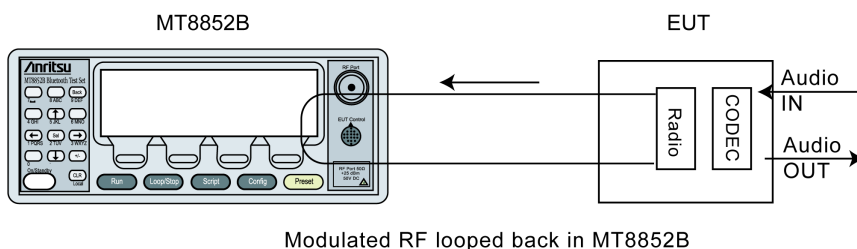

Figure 14-1. Testing using Remote Loopback

1. Press **Config** > "MT8852B" > "Audio" to display the page below.

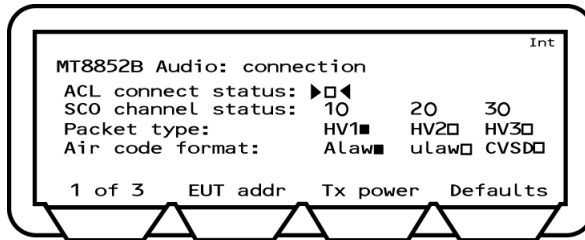

Figure 14-2. MT8852B Audio Connection

Note The RF level used is the same level as that set for the script that was last run.

2. Press the [EUT addr] soft key and set the EUT address in the normal manner. Refer to chapter 6 for details.
3. Move the cursor to "ACL connect status" and press **Sel** to establish an ACL connection. When the ACL connection has been established, the square indicator at the right of this item becomes solid and, if the EUT supports SCO, the indicators on the "SCO channel status" line change to hollow squares to reflect this.
4. If the address source is set to RS232, or USB it is necessary to make the EUT settings shown in the page below. Press the [1 of 3] soft key followed by the [2 of 3] soft key to display the third page.

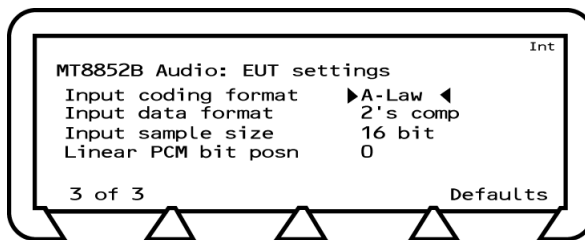

Figure 14-3. Audio EUT Settings

Note No settings are required on this page if the EUT address source is not set to RS232 or USB. Skip to step 7 in this procedure if not initializing the EUT using the MT8852B "EUT Control" interface.

- Input coding format: Select the EUT baseband sample input/output data format. There are three possible settings, "Linear", "A-Law", and "u-Law".
- Input data format: Select the EUT baseband sample data format. There are three possible settings, "1's", "2's", and "sign magnitude".
- Input sample size: Select either an 8 or 16 bit baseband sample size.

Linear PCM bit Posn: Set the EUT Baseband sample offset within the 16 bit field. Specify a value within the range of 0 to 7.

Note

When these settings are complete it will not be necessary to repeat this procedure unless the EUT is changed.

5. Press [3 of 3] to return to page 1 and press the [TX power] soft key.
6. Press **(Sel)** and enter the "TX power level" of packets transmitted from the MT8852B RF test port. The power level can be set to a value between 0 and -90 dBm.

Note

An ACL connection must be made before an SCO link can be established. When a device makes an ACL connection, it reports within its "Supported Features" response whether or not it supports SCO connections, and if so, which HV packet types it can support. Do not establish a SCO connection at this stage.

7. Press the [1 of 3] soft key to display the second page.

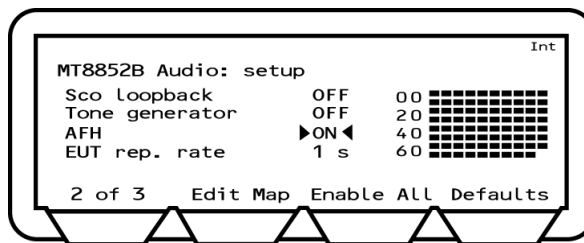

Figure 14-4. MT8852B Audio Setup

8. Move the cursor to "SCO Loopback" and press **(Sel)** to turn remote loopback "ON".
9. Move the cursor to "Tone Generator" and press **(Sel)** to turn this ON or OFF as required. Setting the tone generator to ON results in the creation of a 1 KHz tone by the MT8852B that is transmitted over the SCO channel.
10. The "AFH" and "EUT rep. rate" settings on this page are used for audio verification of EUT adaptive frequency hopping. Refer to chapter 15, Adaptive Frequency Hopping, for a full explanation of this variant of AFH testing.

11. Press the [2 of 3] soft key followed by the [3 of 3] soft key to return to the first page.

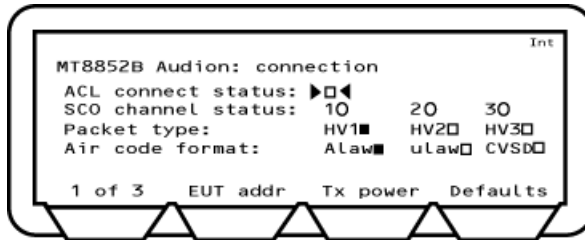

Figure 14-5. MT8852B Audio Connection

12. Move the cursor to "Packet type" and select the HV packet type to be used. When the packet type is selected, the indicator to the right changes from hollow to solid.

Note Some EUTs may not support all packet types. Only packet types reported as supported in "supported features" are available.

HV1

Speech length / packet: 10 voice bytes (1.25 ms of speech)
 Payload length: 240 bits
 FEC: 1/3 FEC
 Transmission rate: Every TX time slot

HV2

Speech length / packet: 20 voice bytes (2.5 ms of speech)
 Payload length: 240 bits
 FEC: 2/3 FEC
 Transmission rate: Every second TX time slot

HV3

Speech length / packet: 30 voice bytes (3.75 ms of speech)
 Payload length: 240 bits
 FEC: None
 Transmission rate: Every third TX time slot

13. Move the cursor to "Air code format", and select the required type. When the packet type is selected, the indicator to the right changes to solid. If the EUT is not being initialized via the MT8852B RS232 control interface, the MT8852B aircode must be set to match the setting of the EUT.

- With all settings made, a SCO connection can now be established. Move the cursor to "SCO channel status" and select the channel or channels over which communications will be performed. Because the HV packet types use varying quantities of the total bandwidth, it may not be possible to select multiple channels with certain packet selections. Refer to the table below.

Table 14-1.

Channel	HV1	HV2	HV3
1	Available	Available	Available
2	Not available	Available	Available
3	Not available	Not available	Available

14-2 Testing the EUT Transmit Path

The performance of the EUT transmitter can be tested in isolation with the set-up shown below.

- Follow the procedure for "Testing the Audio Performance using Remote Loopback" but set the "SCO Loopback" setting to "OFF".

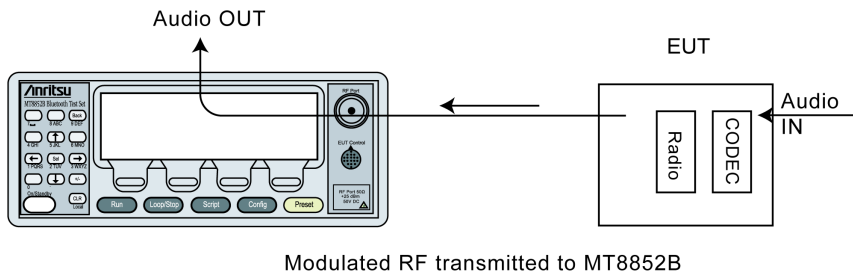

Figure 14-6. Audio Performance of the EUT Transmit Path

Refer to the figure below for details of jack plug wiring.

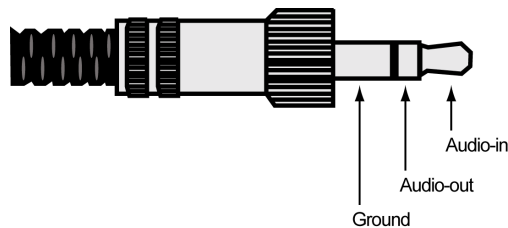

Figure 14-7. Jack Plug Wiring

14-3 Testing the EUT Receive Path

The performance of the EUT receiver can be tested in isolation with the set-up shown below.

As a replacement for the external audio IN, it is also possible to use an internally generated tone. Use of this tone is ideal for quick tests and, as it is generated internally, it does not pass through the MT8852B CODEC. The tone is fixed at 1 kHz. For measurement at other frequencies use of external audio is required.

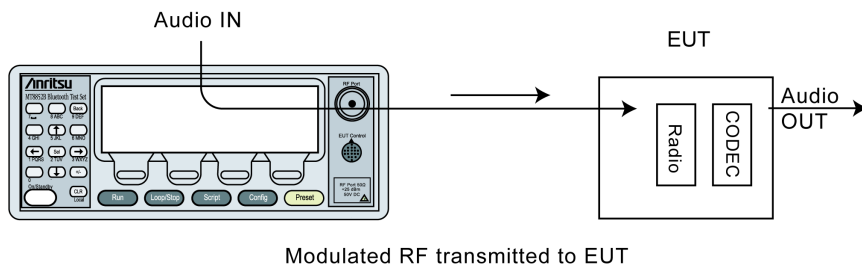

Figure 14-8. Testing Performance of EUT Receive Path

Note Refer to the jack plug diagram shown earlier.

1. Follow the procedure for "Testing the Audio Performance using Remote Loopback" but set the "SCO Loopback" setting to "OFF".
2. Set the "SCO tone generator" on page 2 of 3 to "ON" or "OFF" as required.

14-4 Putting the EUT into Remote Loopback

It is also possible to put the EUT into remote loopback. The MT8852B will then send and receive SCO packets from the EUT. The packets will be looped back digitally in the EUT baseband and will not introduce any distortion from the analogue circuits.

As with the set-up for testing the performance of the receiver, it is also possible to use an internally generated 1 kHz tone. Use of this tone is ideal for quick tests, and as it is generated internally, it does not pass through the MT8852B CODEC. The tone is fixed at 1kHz. For measurements at other frequencies use of external audio is required.

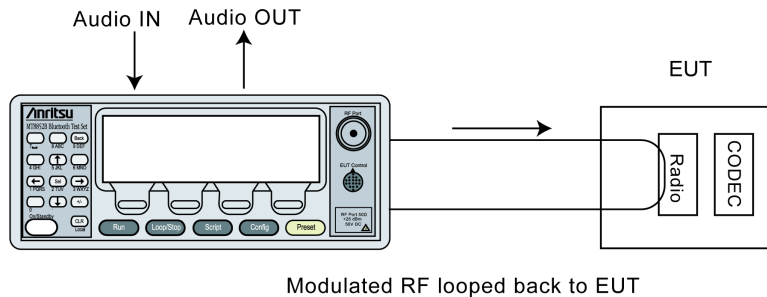

Figure 14-9. Remote Loopback

Note Refer to the jack plug diagram on the previous page.

1. Follow the procedure for "Testing the EUTs Audio Performance" and use the HCI software on the control PC to set the EUT to remoter loopback. SCO loopback for the MT8852B should be set to "OFF".
2. Set the "SCO tone generator" on page 2 of 3 to "ON" or "OFF" as required.

14-5 Using Audio Measurements with AFH

1. Press **Config** > "MT8852B" > "Audio".
2. Press the [1 of 3] soft key to display page 2 of the audio section as shown below.

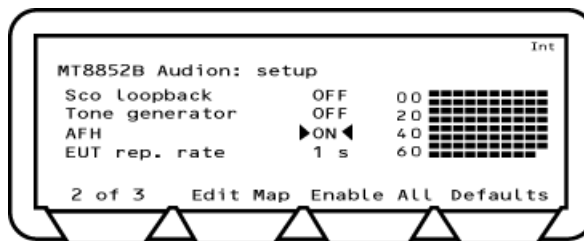

Figure 14-10. MT8852B Audio Setup

3. Set up an audio connection as detailed earlier in this chapter.

4. Introduce an interferer to add noise to the audio channel.
5. Verify the EUT's performance by turning on AFH (on the page shown above) and listening to the decrease in noise as channels identified with interference are blocked.

Chapter 15 — Adaptive Frequency Hopping (Option 15)

15-1 Overview of Adaptive Frequency Hopping (AFH)

AFH is a method used to improve the transmission quality within the ISM frequency band. It is used to prevent hopping to channels that are currently being used by an interfering 802.11 radio in the 2.4 GHz ISM band.

When two *Bluetooth* devices connect under normal circumstances, they establish a basic frequency hopping scheme across the 79 frequency channels in the 2.4 GHz ISM band, hopping at a rate of 1600 times per second. However, as is becoming increasingly common, interference may be encountered in environments where other wireless technologies, such as WLAN or DECT, are also in use in the same radio band. Blocked channels, caused by interference, result in a deterioration in the performance of the connection and this in turn is manifested in poor voice quality or reduced data transfer rates.

To limit the impact of this interference, an adaptation on frequency hopping, known as Adaptive Frequency Hopping (AFH) was introduced by the *Bluetooth* Special Interest Group in the 1.2 *Bluetooth* specification. AFH aims to restore the performance of a *Bluetooth* connection by identifying channels with high error rates and excluding the use of these channels thereafter.

The figure below shows an example of *Bluetooth* packets being blocked by WLAN transmission within the same radio band.

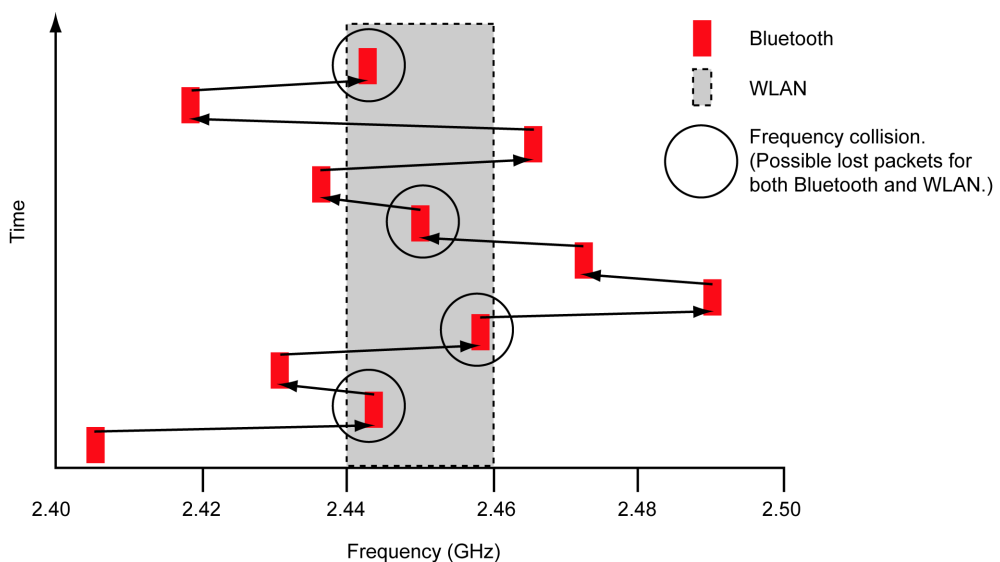

Figure 15-1. Frequency Collision

When AFH is enabled, the channels in use by WLAN are excluded and the *Bluetooth* packets are restricted to other channels where there is little probability of interference.

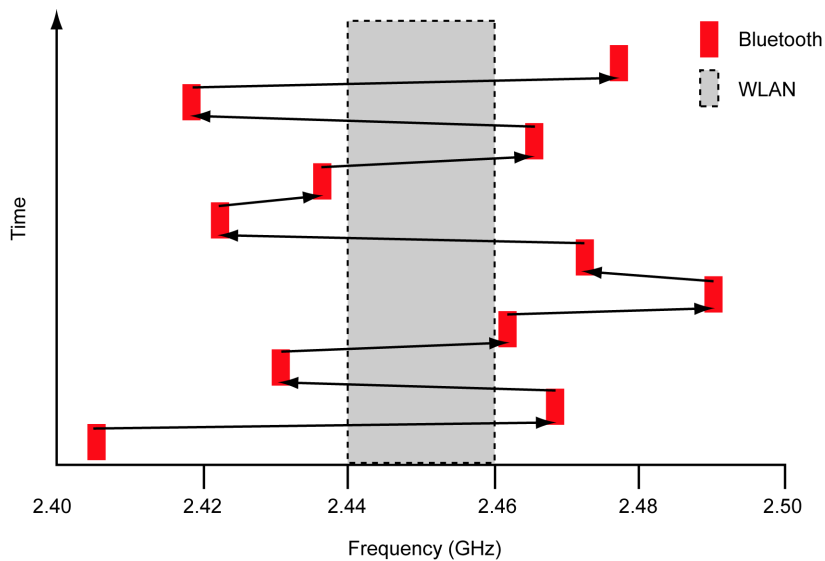

Figure 15-2. Adaptive Frequency Hopping

15-2 AFH Processing

AFH allows *Bluetooth* devices to adapt to the environment by identifying sources of interference and then omitting them from the list of channels available for use.

To use AFH on a connection, both master and slave devices must support the feature, and the master selects whether or not to enable its use. When enabled, the master device generates a channel map to inform the slave device which of the 79 channels are available for use and which have been excluded.

The channel map is generated based on information from any or all of the following three sources.

- Channel classification sent over the HCI from the Host Controller. This would be applicable in the case of a PC supporting both *Bluetooth* and WLAN.
- The results of monitoring in the master device to build up a picture of which channels are experiencing interference problems. This information is referred to as the master's local assessment scheme (MLAS).
- The results of monitoring in the slave device to build up a picture of which channels are experiencing interference problems. This information is referred to as the slave's local assessment scheme (SLAS) and is relayed back to the master in channel classification reports.

Channel map generation is illustrated in the figure below.

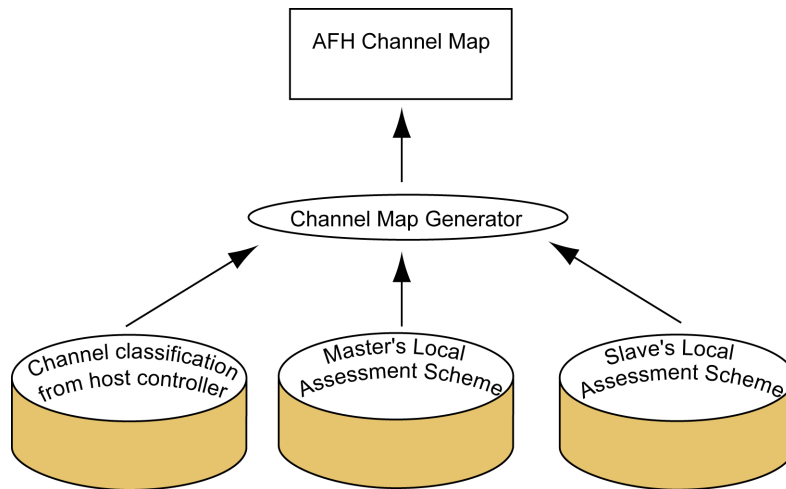

Figure 15-3. Channel Map Generation

The channel map can be modified by the master device at any time during the life of a connection and is adopted immediately upon transmission to the slave.

In addition to the channel map, AFH also requires that *Bluetooth* devices communicate using the Same Channel Mechanism whereby, instead of changing frequency with each transmit and receive slot, the frequency is only changed after each complete transmit and receive cycle.

15-3 AFH in *Bluetooth* 1.2

The *Bluetooth* Specification states that the master device creates the AFH Channel Map from any of the three sources identified above, but it does not dictate the method of channel assessment that should be used to identify the good and bad channels. Two common methods for making this judgement are Received Signal Strength Indication (RSSI), and Packet Error Rate (PER).

The following changes have been made to the 1.2 specification to enable the use of AFH.

- New messages have been added to the Link Manager Protocol to enable communication of the channels that can be used and the channels that have been blocked.
- Commands have been added to the Host Controller Interface to allow the blocking of "known bad" channels and to allow the host to obtain the channel map currently in use.

15-4 MT8852B AFH

Adaptive frequency hopping is not enabled automatically when the MT8852B connects to a slave device that also supports AFH. The Host Controller must send explicit commands to enable or disable AFH operation.

The MT8852B has no algorithms for identifying the usability of channels, and as a result does not generate a "local assessment scheme". Instead, commands at the user interface can be used to block channels in the creation of a "pseudo local assessment map". The resultant active channel map is the logical OR of this pseudo local assessment map and the slave's local assessment scheme (if the user enables use of this data). This is shown in the figure below.

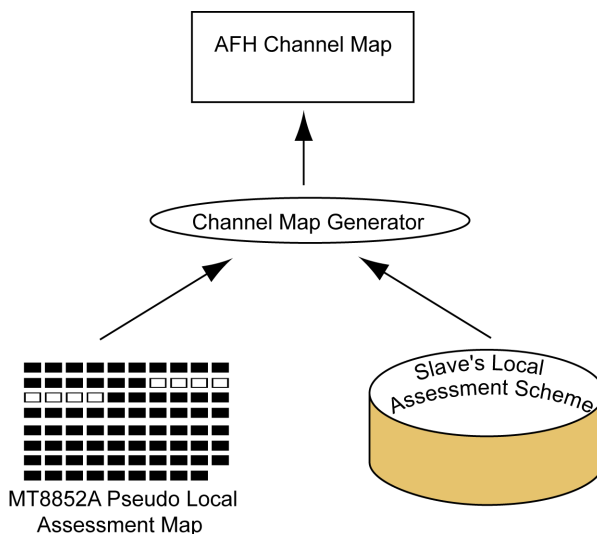

Figure 15-4. AFH Channel Map

The Host Controller may change the AFH Channel Map at any time by sending an HCI command to the *Bluetooth* Controller. If there is an active connection that has AFH enabled, the new AFH Channel Map is adopted immediately. At other times the AFH Channel Map is stored in the *Bluetooth* Controller and used when AFH is next enabled.

The MT8852B gives the user three methods of verifying that AFH is functioning correctly:

- From Channel Use vs Time Information
- From FER vs Time Information
- From AFH from audio measurements

Note

The majority of EUTs are not able to update the AFH local assessment when being operated in test mode.

15-5 AFH Test Configuration

1. Press **Config** > "MT8852B" > "AFH Measurements".
2. Press **Sel** to display the page shown below.

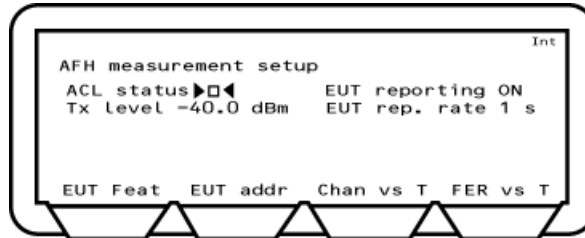

Figure 15-5. AFH Measurement Setup

3. If the MT8852B is not already in an ACL connection with the EUT, a connection must now be established. Select the required EUT address source then select "ACL Status" and press **Sel**.
4. As mentioned in the previous section, the channel map is compiled from information from the MT8852B pseudo local assessment map and the EUT's local assessment scheme. Use of the latter is controlled by setting "EUT Reporting" to "On" or "Off". If set to "On", the EUT's local assessment scheme is used, and the rate at which the assessment is transmitted to the MT8852B is controlled by the setting at "EUT Rep. Rate". Enter a rate of between 1 and 30 seconds.
5. Select "TX Level" and enter the power level at which the MT8852B will transmit all packets whilst in AFH mode.

Note

The *Bluetooth* specification does not define how an EUT shall determine if a channel should be assessed as good or bad. Each chipset developer has implemented a unique channel assessment solution. The MT8852B displays the channel assessment map that a specific EUT has reported as a result of the continuous Poll/Null connection that exists between the MT8852B and the EUT.

15-6 Assessing AFH

Channel Use vs Time

Using this method the user can either edit the MT8852B's pseudo local assessment to simulate interference by blocking specific channels, or turn on an interference source and monitor the channels that are blocked automatically. The performance of the EUT can then be validated using the EUT's support software and the graph of channel use over time displayed by the MT8852B.

1. Configure the MT8852B as detailed earlier in this chapter.

- Press the [Chan vs T] soft key to display the page shown below.

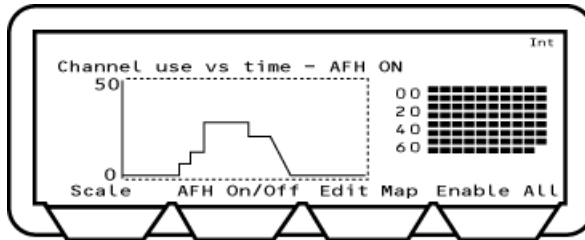

Figure 15-6. Channel Use vs Time

- Press the [AFH On/Off] soft key to enable AFH. The current AFH status is shown in the display above the graph area.

Note

If option 15 (AFH) is enabled, the time taken to establish a connection displays on the top line of the page shown above. An example of the display is shown below.

Connection made (1: 1054 ms)

The digit prior to the colon ("1" in the case of the example above) represents the number of attempts required to establish the connection. The figure following the colon represents the time in milliseconds taken to establish the connection.

- Turn on the interfering source, or, if simulating interference, press the [Edit Map] soft key to display the page shown below.

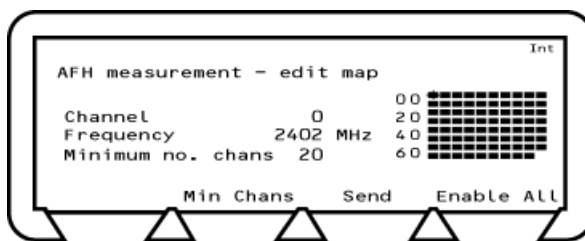

Figure 15-7. AFH Measurement Edit Map

- Use the arrow keys on the keypad to position the cross-hairs (shown in the figure above on the upper left channel) on the required channel(s), and press the key to turn the channels on or off.
- When all the required channels have been 'blocked', press the [Send] soft key to update the active channel map.
- The results can be verified by using the EUT's support software and by returning to the previous page and viewing the graph of channel use over time.

FER vs Time

Using this method the user activates an interference source into the EUT in order to validate that the EUT can recognize the channels that should be blocked. The performance of the EUT can be monitored at the MT8852B by confirming that the frame error rate shown on the graph drops as the channels in the channel plan to the right are blocked as required. FER is measured by counting the number of Null packets returned by the EUT as a result of the number of transmitted Poll packets. The FER measurement runs at a one second interval, and the FER measurement is always made on 800 transmitted packets.

1. Configure the MT8852B as detailed earlier in this chapter.
2. Apply interference to the EUT.
3. Press the [FER vs T] soft key to display the page shown below.

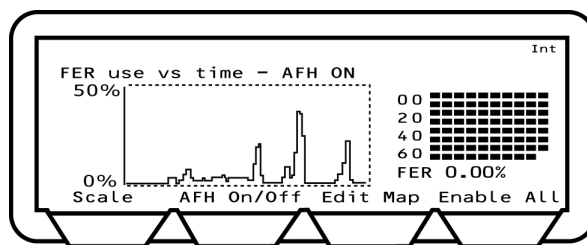

Figure 15-8. FER Use vs Time

4. Press the [AFH On/Off] soft key to enable AFH. The current AFH status is shown in the display above the graph area.
5. Activate the interference source into the EUT.
6. Confirm that the graph of FER over time drops down to zero as channels are systematically identified and blocked by the EUT.

Note When displaying [Channel vs Time] and [FER vs Time], the MT8852B is sending Poll packets to the EUT in each transmit slots (800 polls a second).

Note It is advisable to disable Inquiry and Page scanning on the EUT while running FER vs time measurements.

Note The decisions made at the EUT regarding which channels are good or bad, will vary significantly depending on the relative level of the interfering source and the MT8852B power level. If the interfering source is connected directly to the EUT and the interfering power level exceeds -20dBm, this may saturate the EUT receiver and cause it to fail. The *Bluetooth* specification for receiver maximum input power is -20dBm.

Audio Measurements

1. Press **Config** > “MT8852B” > “Audio”.
2. Press the [1 of 3] soft key to display page 2 of the audio section as shown below.

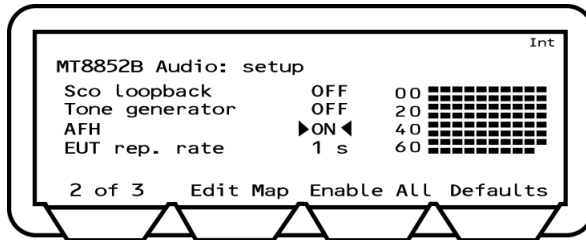

Figure 15-9. MT8852B Audio Setup

3. Set up an audio connection as detailed in chapter 14 of this manual.
4. Introduce an interferer to add noise to the audio channel.
5. Verify the EUT's performance by turning on AFH (on the page shown above) and listening to the decrease in noise as channels identified with interference are blocked.

Chapter 16 — IQ Data Output (Option 17)

The IQ data output software provides users with a means of capturing and viewing received packets without using protocol or making an ACL connection. This option is useful for more detailed analysis of the transmitter performance of EDR chips and products that do not have a functional protocol stack. Three of the EDR transmitter measurements specified in the *Bluetooth* RF test specification can be performed.

Note It is not necessary to purchase option 17 to run EDR measurements on the MT8852B or MT8852B-042 model types.

16-1 Software Overview

- Performs all measurements from a simple user interface with no signaling required.
- Performs three EDR transmitter test cases (relative transmit power, carrier frequency stability, differential phase encoding).
- Allows the user to print and save test results.
- Supports 2-DH1, 2-DH3, 2-DH5, 3-DH1, 3-DH3, and 3-DH5 packets.

The [Anritsu *Bluetooth* EDR transmitter test software] window is divided into a number of panes. The measurement settings are made at the left side of the window and the results of measurement display to the right.

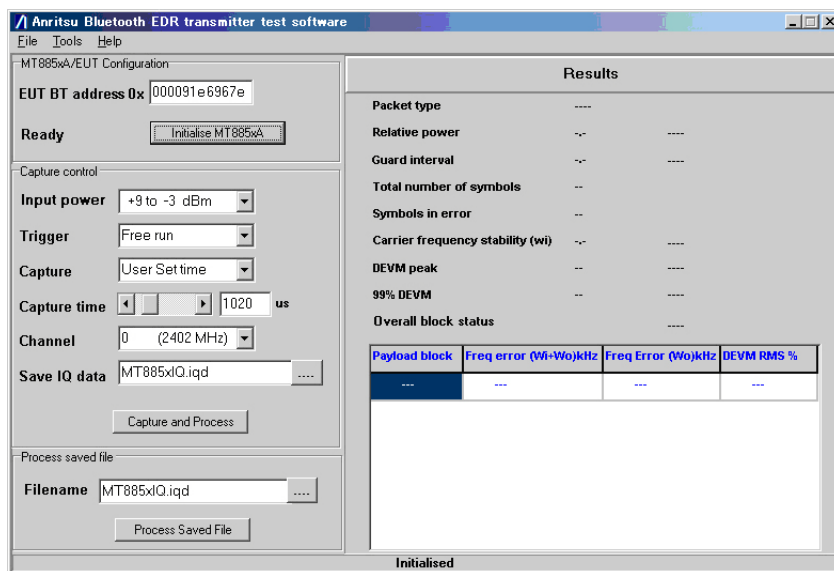

Figure 16-1. Anritsu *Bluetooth* EDR Transmitter Test Software

16-2 EDR Measurements

Relative Transmit Power (TP/TRM/CA/BV-10-C)

This test ensures that the difference in average transmit power during the frequency modulated [GFSK] and phase modulated [DPSK] parts of a packet is within the range specified below.

Pass criteria = $(P_{\text{GFSK}} - 4\text{dB}) < P_{\text{DPSK}} < (P_{\text{GFSK}} + 1\text{dB})$

Carrier Frequency Stability (TP/TRM/CA/BV-11-C)

This test verifies the transmitter carrier frequency stability and modulation accuracy. The measurement results must fulfill the following conditions.

Average frequency error of the GFSK portion of the EDR packet - ω_i (Pass criteria $\pm 75\text{kHz}$)

Average frequency error of each payload block - ω_0 (Pass criteria $\pm 10\text{ kHz}$)

Modulation Accuracy

In this measurement, the payload is divided into blocks of $50\ \mu\text{s}$ and the DEVM is measured for each symbol in the block. The pass criteria for this test are as follows.

RMS DEVM ≤ 0.20 for all $\pi/4$ -DQPSK blocks

RMS DEVM ≤ 0.13 for all 8DPSK blocks

Peak DEVM ≤ 0.35 for all $\pi/4$ -DQPSK symbols

Peak DEVM ≤ 0.25 for all 8DPSK symbols

99% DEVM ≤ 0.30 for 99% of $\pi/4$ -DQPSK symbols

99% DEVM ≤ 0.20 for 99% of 8DPSK symbols

Differential Phase Encoding (TP/TRM/CA/BV-12-C)

In this measurement the EUT transmits a packet with a defined PRBS9 payload. The payload of the received packet is demodulated and compared with the defined ideal packet to give a resultant symbol error rate. The *Bluetooth* RF test specification stipulates that zero errors are detected in 99% of 100 packets transmitted.

Guard Interval

The guard time is defined as the period starting at the end of the last GFSK symbol of the header and ending at the start of the reference symbol of the synchronization sequence. The length of the guard time must be between $4.75\ \mu\text{s}$ and $5.25\ \mu\text{s}$.

16-3 Saving Results

The results of measurement can be saved to a text file or printed in the style shown below.

ANRITSU Bluetooth EDR transmitter test results

Date : 1 February 2010

Time : 10:14

Bluetooth address : 0x000091e6789e

Packet type : 2-DH1

TP/TRM/CA/10/C Relative transmitter power test

Relative power : -1.0 dB PASS

Guard interval : 5.00 us PASS

TP/TRM/CA/12/C EDR Differential Phase Encoding test

Total number of symbols : 216

Symbols in error : 0

TP/TRM/CA/11/C Carrier Frequency Stability and Modulation Accuracy test

Carrier frequency stability (ω_i) : -4.9 kHz PASS

DEVM peak : 13 % PASS

DEVM 99% : 12 % PASS

Overall block status : PASS

Payload Block	Freq error ($\omega_i + \omega_o$) kHz	Freq error (ω_o) kHz	DEVM RMS
1	-4.9	-0.0	5
2	-6.0	-1.2	6
3	-4.3	-0.6	6

Figure 16-2. EDR Test Results

16-4 Handling Results

Generating a Power Burst Profile Graph

A power burst profile can be generated from either the current set of measurement results or from previously saved IQ data.

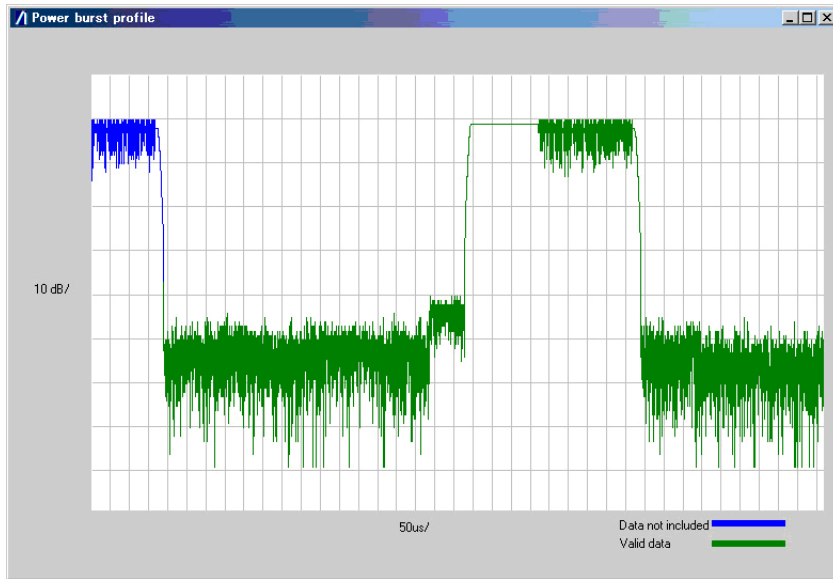

Figure 16-3. Power Burst Profile

Generating Graphs from IQ Data

The automatically saved IQ data file can be opened in Microsoft Excel or similar spread-sheet package to generate power graphs and vector diagrams.

Chapter 17 — Technical Support

Although every effort has been made to ensure the quality and reliability of this product, there may be times when operation difficulties are experienced and technical support is required.

17-1 Contacting Support

For immediate assistance contact your local Anritsu sales engineer or field application engineer. A list of all regional offices can be found on our internet site at the following location: <http://www.anritsu.com/contact.asp>.

17-2 Reporting Problems

Technical support can also be obtained by sending an e-mail to our technical support team at bluetooth.support@anritsu.com. Please include the details below.

- MT8852B serial number
- Description of the problem
- List of error messages displayed
- Description of procedure to replicate the problem
- Details of efforts already made to correct the problem

Every effort will be made to ensure that a response is provided within three working days.

17-3 Anritsu Service Centers

A list of all Anritsu service centers is provided on our internet site at the following location: <http://www.anritsu.com/contact.asp>.

Appendix A — Specifications

A-1 MT8852B Specification

Characteristic/ Parameter	Specification
Basic Rate measurements	All measurements made in compliance with Bluetooth core specifications 3.0 + HS Test Suite Structure (TSS) and Test Purposes (TP) Specification 1.2/2.0/2.0 + EDR/2.1/2.1 + EDR/3.0/3.0 + HS.
Output Power	TRM/CA/BV-01-C
Measurement configuration	Hopping: OFF or ON – measure at Defined, All, or Any frequencies Loopback or TX mode Payload: PRBS 9 Packet type: DH1, DH3, DH5
Displayed results	Average power Peak power
Number of measurement frequencies	Three, default to RF Test Specification or user defined
Measurement range	+22 dBm to –50 dBm average power (+23 dBm peak power)
Resolution	0.1 dB
Accuracy	+20 dBm to –35 dBm, ±1 dB +22 dBm to +20 dBm, ±1.5 dB
Power Control	TRM/CA/BV-03-C
Measurement configuration	Hopping: OFF Loopback or TX mode Payload: PRBS 9 Packet type: DH1, DH3, DH5
Displayed results	Maximum power Minimum power Maximum step size Minimum step size Power at each power step
Number of measurement frequencies	Three, default to RF Test Specification or user defined
Measurement range	+22 dBm to –35 dBm average power (+23 dBm peak power)
Resolution	0.1 dB

MT8852B Specification

Accuracy	+20 dBm to –35 dBm, ± 1 dB +22 dBm to +20 dBm, ± 1.5 dB
Enhanced Power Control	TRM/CA/BV-14-C
Measurement configuration	Hopping: OFF Loopback or TX mode Payload: PRBS9 Packet type: DH1, 2DH1, 3DH1
Displayed result	Maximum power for each packet type Minimum power for each packet type Maximum power step for each packet type Minimum power step for each packet type Maximum power difference at any step between DHn and 2DHn or 3DHn packets
Number of measurement frequencies	Three, default to RF Test Specification or user defined
Measurement range	+22 dBm to -35 dBm average power (+23 dBm peak power)
Resolution	0.1 dB
Accuracy	+20 dBm to -35 dBm, ± 1.0 dB +22 dBm to +20 dBm, ± 1.5 dB
Initial Carrier Frequency Tolerance	TRM/CA/BV-08-C
Measurement configuration	Hopping: OFF or ON – measure at Defined, All, or Any frequencies Loopback or TX mode Payload: PRBS 9 Packet type: DH1
Displayed results	Average initial frequency error Maximum positive frequency error Maximum negative frequency error
Number of measurement frequencies	Three, default to RF Test Specification or user defined
RF input measurement range	+20 dBm to -35 dBm
Initial frequency error measurement range	0 Hz to ± 150 kHz
Frequency resolution	1 kHz
Accuracy	500 Hz \pm Frequency Standard
Carrier Frequency Drift	TRM/CA/BV-09-C

Measurement configuration	Hopping: OFF or ON – measure at Defined, All, or Any frequencies Loopback or TX mode Payload: 10101010 Packet type: DH1, DH3, DH5
Displayed results	Carrier frequency drift Drift rate
Number of measurement frequencies	Three, default to RF Test Specification or user defined
RF input measurement range	+20 dBm to –35 dBm
Frequency drift measurement range	0 Hz to 200 kHz, and >2000/50 μ s
Frequency resolution	1 kHz
Characteristic/Parameter	Specification
Sensitivity - Single Slot Packets	RCV/CA/BV-01-C
Measurement configuration	Hopping: OFF or ON, user selectable Loopback only Payload: PRBS9 Packet type: DH1 Dirty transmitter (as defined in the RF test spec): ON or OFF, user defined
Displayed results	BER (percentage) Total number of bit errors and FER
Number of measurement frequencies	Three, default to RF Test Specification or user defined
Number of measured bits	1 to 10,000 packets (216 to 2,160,000 bits)
Output power range	0 dBm to –90 dBm, resolution 0.1 dB
Output power accuracy	\pm 1 dB, 0 dBm to –80 dBm
BER/FER measurement range	0.000% to 100%
BER/FER resolution	0.001%
Sensitivity - Multi Slot Packets	RCV/CA/BV-02-C

MT8852B Specification

Measurement configuration	Hopping: OFF or ON, user selectable Loopback only Payload: PRBS 9 Packet type: DH3, DH5 Dirty transmitter (as defined in RF test spec): ON or OFF, user defined
Displayed results	BER (percentage) Total number of bit errors and FER
Number of measurement frequencies	Three, default to RF Test Specification or user defined
Number of measured bits	1 to 10,000 packets (for DH3, 1,464 to 14,640,000 bits), (for DH5, 2,712 to 27,120,000 bits)
Output power range	0 dBm to –90 dBm, 0.1 dB resolution
Output power accuracy	±1 dB, 0 dBm to –80 dBm
BER/FER measurement range	0.000% to 100%
BER/FER resolution	0.001%
Modulation Index	TRM/CA/BV-07-C
Measurement configuration	Hopping: OFF Loopback or TX mode Payload: 11110000 and 10101010 Packet type: DH1, DH3, DH5
Displayed results	Frequency deviation Δf_{1max} Δf_{2max} Δf_{1avg} Δf_{2avg} and $\Delta f_{2avg}/\Delta f_{1avg}$ plus % of $\Delta f_{2max} < 115$ kHz
Number of measurement frequencies	Three, default to RF Test Specification or user defined
RF input measurement range	+20 dBm to –35 dBm
Deviation measurement range	0 Hz to 350 kHz peak
Deviation resolution	1 kHz
Accuracy	1% for modulation index = 0.32
Maximum Input Power	RCV/CA/BV-06-C

Measurement configuration	Hopping: OFF Loopback only Payload: PRBS 9 Packet type: DH1
Displayed results	BER (percentage) Total number of bit errors and FER
Number of measurement frequencies	Three, default to RF Test Specification or user defined
Number of measured bits	1 to 10,000 packets (216 – 2,160,000 bits)
Output power range	0 dBm to –90 dBm, resolution 0.1 dB
Output power accuracy	±1 dB, 0 dBm to –80 dBm
EDR Measurements	
EDR Relative Transmit Power	TRM/CA/BV-10-C
Measurement configuration	Hopping: Off and On – measure at Defined, All, or Any frequencies Modulations: $\pi/4$ DQPSK and 8DPSK Packet type: 2-DH1, 3, 5 and 3-DH1, 3, 5 Loopback or Tx mode EUT power level: Max and Min
Displayed results	Max differential power (from all packets) Min differential power (from all packets) Average differential power (over all packets)
Number of measurement frequencies	Three, default to RF Test Specification or user defined
Measurement range	+20 to –35 dBm average power, (+23 dBm peak power)
Relative power resolution	0.01db, GFSK to $\pi/4$ DQPSK and 8DPSK
Relative power accuracy	Relative power measurement accuracy between GFSK and $\pi/4$ DQPSK or 8DPSK, 0.2 dB typical for a power difference of <6 dB
Relative power measurement range	Relative power measurement range between GFSK and $\pi/4$ DQPSK or 8DPSK, (PGFSK–8 dB) < PDPSK < (PGFSK +4 dB)
EDR Carrier Frequency Stability and Modulation Accuracy	TRM/CA/BV-11-C

MT8852B Specification

Measurement configuration	Hopping: Off and On – measure at Defined, All, or Any frequencies Modulations: $\pi/4$ DQPSK and 8DPSK Packet type: 2-DH1, 3, 5 and 3-DH1, 3, 5 Loopback or Tx mode EUT power level: Max and Min
Displayed results	Initial frequency error ω_i Frequency error ω_o Frequency error $\omega_i + \omega_o$ RMS DEVM (block with greatest DEVM value displayed) Peak DEVM 99% DEVM Average RMS DEVM (average DEVM for all blocks measured)
Number of measurement frequencies	Three, default to RF Test Specification or user defined
Carrier frequency stability measurement range	0 Hz to ± 100 kHz
Carrier frequency stability accuracy	500 Hz \pm Frequency Standard
Carrier frequency stability resolution	1 kHz
RMS DEVM range	30% $\pi/4$ DQPSK, 20% 8DPSK
RMS DEVM resolution	0.1% $\pi/4$ DQPSK and 8DPSK
Peak DEVM range	0 to 50% $\pi/4$ DQPSK, 0 to 30% 8DPSK
Peak DEVM resolution	0.1% $\pi/4$ DQPSK and 8DPSK
EDR Differential Phase Encoding	TRM/CA/BV-12-C
Measurement configuration	Hopping mode: OFF and ON, user selectable Modulations: $\pi/4$ DQPSK and 8DPSK Packet type: 2-DH1, 3, 5 and 3-DH1, 3, 5. Number of test packets: default 100 Tx mode only
Displayed results	Number of packets received Number of packets with payload data errors Percentage of errored packets
Number of measurement frequencies	Three, default to RF Test Specification or user defined
EDR Sensitivity	RCV/CA/BV-07-C

Measurement configuration	<p>Hopping mode: OFF and ON, user selectable</p> <p>Modulations: $\pi/4$DQPSK and 8DPSK</p> <p>Packet type: 2-DH1, 3, 5 and 3-DH1, 3, 5.</p> <p>Bit threshold control: Threshold 1, 1.6 million bits, Threshold 2, 16 million bits (user editable)</p> <p>Loopback only</p> <p>Dirty transmitter (as defined in RF test spec): ON or OFF, user selectable</p>
Displayed results	<p>Overall BER (displayed in exponential format)</p> <p>Number of bits in error</p> <p>Number of packets sent by test set</p> <p>Number of packets received in error by EUT</p>
Number of measurement frequencies	Three, default to RF Test Specification or user defined
Output power range	0 to -90 dBm, resolution 0.1 dB
Output power accuracy	± 1 dB, 0 dBm to -80 dBm
EDR BER Floor Performance	RCV/CA/BV-08-C
Measurement configuration	<p>Modulations: $\pi/4$DQPSK and 8DPSK</p> <p>Packet type: 2-DH1, 3, 5 and 3-DH1, 3, 5</p> <p>Bit threshold control: Threshold 1, 8 million bits, Threshold 2, 160 million bits (user editable)</p> <p>Loopback only</p> <p>Hopping: OFF and ON, user selectable</p>
Displayed results	<p>Overall BER (displayed in exponential format)</p> <p>Number of bits in error</p> <p>Number of packets sent by test set</p> <p>Number of packets received in error by EUT</p>
Number of measurement frequencies	Three, default to RF Test Specification or user defined
Output power range	0 to -90 dBm, resolution 0.1 dB
Output power accuracy	± 1 dB, 0 dBm to -80 dBm
EDR maximum Input Level	RCV/CA/BV-10-C

MT8852B Specification

Measurement configuration	Hopping: OFF and ON, user selectable Modulations: $\pi/4$ DQPSK and 8DPSK Packet type: 2-DH1, 3, 5 and 3-DH1, 3, 5 Number of bits: default 1.6 million (user editable) Loopback only
Displayed results	Overall BER (displayed in exponential format) Number of bits in error Number of packets sent by test set Number of packets received in error by EUT
Number of measurement frequencies	Three, default to RF Test Specification or user defined
Output power range	0 to -90 dBm, resolution 0.1 dB
Output power accuracy	± 1 dB, 0 dBm to -80 dBm
Low Energy Measurements	BLE measurements made in compliance with <i>Bluetooth</i> RF test specification RF-PHY.TS/5.0.0.
BLE Output power	TRM-LE/CA/BV-01-C
Measurement configuration	DUT configured to transmit Test Reference Packets. Packet payload: PRBS9
Displayed results	Average power Peak to average power
Number of measurement frequencies	Three, default to RF Test Specification or user defined
Measurement range	+22 dBm to -50 dBm average power (+23 dBm peak power)
Resolution	0.1 dB
Accuracy	+20 dBm to -35 dBm, ± 1.0 dB +22 dBm to +20 dBm, ± 1.5 dB
BLE Modulation characteristics	TRM-LE/CA/BV-05-C (BLE), TRM-LE/CA/BV-09-C (BLE Stable) TRM-LE/CA/BV-10-C (2LE), TRM-LE/CA/BV-11-C (2LE Stable) TRM-LE/CA/BV-13-C (BLR S=8)
Measurement configuration	DUT configured to transmit Test Reference Packets. Packet payload: 10101010 and 11110000 (BLE and 2LE) Packet payload: 11111111 (BLR S=8)

Displayed results	<p>Frequency deviation:</p> <p>Δf_{1max},</p> <p>Δf_{2max}, (BLE and 2LE)</p> <p>Δf_{1avg},</p> <p>Δf_{2avg}, (BLE and 2LE)</p> <p>$\Delta f_{2avg} / \Delta f_{1avg}$ ratio, (BLE and 2LE)</p> <p>%Δf_{2max}, > 185 kHz (BLE)</p> <p>%Δf_{2max}, > 370 kHz (2LE)</p>
Number of measurement frequencies	Three, default to RF Test specification or user defined
Measurement range	<p>RF input: +20 dBm to -35 dBm</p> <p>Deviation: 0 Hz to 500 kHz peak (except 2LE)</p>
Resolution	Deviation: 1 kHz
Accuracy	1% for modulation index 0.5
BLE Carrier frequency offset and drift	TRM-LE/CA/BV-06-C (BLE), TRM-LE/CA/BV-12-C (2LE), TRM-LE/CA/BV-14-C (BLR S=8)
Measurement configuration	<p>DUT configured to transmit Test Reference Packets.</p> <p>Packet payload: 10101010 (BLE and 2LE)</p> <p>Packet payload: 11111111 (BLR S=8)</p>
Displayed results	<p>Carrier frequency error</p> <p>Frequency drift</p> <p>Drift rate</p> <p>Initial drift rate</p>
Number of measurement frequencies	Three, default to RF Test Specification or user defined
Measurement range	<p>RF input: +20 dBm to -35 dBm</p> <p>Frequency: 500 kHz</p>
Frequency Resolution	1 kHz
Accuracy	500 Hz \pm Frequency standard
BLE Receiver sensitivity	RCV-LE/CA/BV-01-C (BLE), RCV-LE/CA/BV-14-C (BLE Stable), RCV-LE/CA/BV-08-C (2LE), RCV-LE/CA/BV-20-C (2LE Stable), RCV-LE/CA/BV-26-C (BLR S=2), RCV-LE/CA/BV-27-C (BLR S=8), RCV-LE/CA/BV-32-C (BLR S=2 Stable), RCV-LE/CA/BV-33-C (BLR S=8 Stable)

MT8852B Specification

Measurement configuration	DUT configured to receive Test Reference Packets. Packet payload: PRBS9 Full support of Dirty Transmitter as defined in test specification
Displayed results	Receiver PER. Requires DUT to support HCI UART or USB or 2-Wire interface for automated PER results.
Number of measurement frequencies	Three, default to RF Test Specification or user defined
Output power range	0 dBm to -90 dBm, resolution 0.1 dB
Output power accuracy	± 1 dB, 0 dBm to -80 dBm
BLE Maximum input signal level	RCV-LE/CA/BV-06-C (BLE), RCV-LE/CA/BV-18-C (BLE Stable) RCV-LE/CA/BV-12-C (2LE), RCV-LE/CA/BV-24-C (2LE Stable)
Measurement configuration	DUT configured to receive Test Reference Packets. Packet payload: PRBS9
Displayed results	Receiver PER. Requires DUT to support HCI UART or USB or 2-Wire interface for automated PER results.
Number of measurement frequencies	Three, default to RF Test Specification or user defined
Output power range	0 dBm to -90 dBm, resolution 0.1 dB
Output power accuracy	± 1 dBm, 0 dBm to -80 dBm
BLE PER report integrity	RCV-LE/CA/BV-07-C (BLE), RCV-LE/CA/BV-19-C (BLE Stable), RCV-LE/CA/BV-13-C (2LE), RCV-LE/CA/BV-25-C (2LE Stable), RCV-LE/CA/BV-30-C (BLR S=2), RCV-LE/CA/BV-31 (BLR S=8), RCV-LE/CA/BV-32-C (BLR S=2 Stable), RCV-LE/CA/BV-33-C (BLR S=8 Stable)
Measurement configuration	DUT configured to receive Test Reference Packets. Packet payload: PRBS9 CRC corruption: Alternate packets Number of test packets: Random [100 RND 1500]
Displayed results	Receiver PER. Requires DUT to support HCI UART or USB or 2-Wire interface for automated PER results.
Number of measurement frequencies	One, default to RF Test Specification or user defined
Output power range	0 dBm to -90 dBm, resolution 0.1 dB
Output power accuracy	± 1 dBm, 0 dBm to -80 dBm
MT8852B Signal Generator	
Frequency	

Frequency range	2.40 to 2.5 GHz
Frequency resolution	1 kHz
Frequency accuracy	As frequency standard ± 500 Hz
Level	
Amplitude range	0 dBm to -90 dBm
Amplitude accuracy	± 1 dB (0 dBm to -80 dBm)
Amplitude resolution	± 0.1 dB
Output impedance	50 (nominal)
Output VSWR	1.5:1 (typically 1.3) Adjacent channels 3 or higher -40 dBc
GFSK modulation	
Modulation index	Variable, 0.25 to 0.50 (125 kHz to 190 kHz)
Modulation index resolution	0.01
Modulation index accuracy	1% for Modulation Index = 0.32
Baseband filter	BT=0.5
$\pi/4$DQPSK modulation	
Modulation index accuracy	<5% RMS DEVM
Baseband filter	BT=0.4
8DPSK modulation	
Modulation index accuracy	<5% RMS DEVM
Baseband filter	BT=0.4
MT8852B Measuring Receiver	
Frequency	
Frequency range	2.40 to 2.5 GHz
Frequency resolution	1 kHz
Frequency accuracy	As frequency standard ± 500 Hz
Level	
Range	+22 dBm to -55 dBm average power
Power measurement accuracy	± 1 dB (+20 dBm to -35 dBm)
Input VSWR	1.5:1
Damage level	+25 dBm
Resolution	0.1 dB

MT8852B Specification

GFSK modulation	
Deviation measurement range	0 to 350 kHz peak
Accuracy	1% for Modulation Index = 0.32
EUT Control Interface	
RS232 HCI commands	The EUT control interface provides RS232 HCI commands to the EUT through a standard RS-232 interface. The interface meets the requirements of the <i>Bluetooth</i> specification for HCI UART transport layer. A RS232 cable is supplied.
USB HCI commands	The EUT control interface provides USB HCI commands to the EUT through a standard USB interface. The interface meets the requirements of the <i>Bluetooth</i> specification section H:2. A USB cable is supplied.
USB->RS232 HCI commands	For use with EUTs fitted with USB->RS232 FTDI chips.
2-Wire control	For test control of Bluetooth low energy devices the EUT control interface supports the 2-Wire specification
Characteristic/Parameter	Specification
Audio Specifications	
Number of SCO channels supported	3
Codec air interfaces supported	CVSD, A-Law, μ -Law
Frequency response	(-3 dB) measured CODEC in to CODEC out: 160 Hz -3.5 kHz. Measured with 50 Ω source impedance and 10 M Ω load impedance
Maximum input / output signal level	3.4 Vpk-pk = 1.2 V RMS
Distortion/noise	A law: typical -37 dB at 1 kHz, 1 V RMS μ law: typical -37 dB at 1 kHz, 1 V RMS CVSD: typical -30 dB at 300 Hz, 1 V RMS
Input/Output connectors	3.5 mm audio jack plugs (one for each SCO channel)
Input impedance	20 k Ω
Minimum output load	600 Ω
Internal audio source	1 kHz fixed frequency
AFH (Option 15)	
Supported in ACL and SCO connections	
Displays	Active channel vs. time, FER vs. time
Other features	ACL connection timer, resolution 1 ms
Frequency Standard	
Frequency	10 MHz
Temperature Stability	\pm 0.5 ppm, -10°C to +85°C

Aging (1st year)	±1.0 ppm
Aging (over 10 years)	±2.5 ppm, including year 1
Rear Panel Connectors	
External frequency standard input	Rear panel BNC socket, 50 Ω 1 volt
Output 1	TTL output for TX ON, TX DATA, RX DATA, and correlator
Output 2	TTL output for RX ON, TX DATA, RX DATA, and correlator
Input 1	For service use only
GPIB	
IEE 488.2	Offers full instrument control as standard
RS232	
RS232	Offers full instrument control as standard
General	
Rated Voltage	100 to 120 Vac / 200 to 240 Vac
Rated Frequency	50/60 Hz
Power Consumption	150 VA Max
Environmental	
Operating temperature	5 to +40°C
Operating humidity	20% to 75%
Safety	Complies with IEC 61010-1
EMC	Conforms to the protection requirements of EEC Council Directive 2014/30/EU
Size and Mass	
Dimensions	216.5 mm x 88 mm x 380 mm
Mass	<3.8 kg

Appendix B — Test Conditions

B-1 Test Condition

As detailed in chapter 5, each test that can be run on the MT8852B has a number of test conditions that determine exactly how the test is performed. The test conditions are set by default to match the requirements defined in the *Bluetooth* specification. The test conditions for scripts 1 and 2 cannot be modified but those for scripts 3 to 10 can be changed by the user to meet requirements.

The table below shows the test conditions that are used in each test.

Table B-1. Test Conditions Per Test

	Hopping	Hopping test mode	No. of packets	Test type	Packet type	Cycles	Packets per step	Min. test power	Measurement delay	Tx power	Payload pkt count	Dirty transmitter	Dirty params table	Toggle payload	DHx packet type	EUT power level	Min sensitivity check	Edit dirty table	Threshold bit count	Total test bit count	Number of bits	Number of blocks	Frequency
Output power																							
Power control																							
Enh. pwr control																							
Initial carrier																							
Carrier drift																							
Single sens.																							
Multi sens.																							
Mod. index																							
Max input pwr																							
Rel. Tx power																							
Carrier & mod.																							

Table B-1. Test Conditions Per Test

	Hopping	Hopping test mode	No. of packets	Test type	Packet type	Cycles	Packets per step	Min. test power	Measurement delay	Tx power	Payload pkt count	Dirty transmitter	Dirty params table	Toggle payload	DHx packet type	EUT power level	Min sensitivity check	Edit dirty table	Threshold bit count	Total test bit count	Number of bits	Number of blocks	Frequency
Diff. phase																							
EDR sens.																							
EDR BER floor																							
EDR max inp. level																							
Output power																							
Carrier drift																							
Mod. index																							
Sensi-tivity																							
PER integrity																							
Max input pwr																							

B-2 Glossary

Cycles

In the power control measurements, this sets the number of power measurement cycles. A power measurement cycle sets the EUT output power to its maximum, steps it down to the minimum, and then up to the maximum again.

In the PER integrity measurement, this represents the number of times that the test is run with a new random number each time.

DHx packet type

The DHx packet type used in all EDR tests. There are five settings (Longest, 2-DH1, 2-DH3, 2-DH5, Off) available for both the 2 and 3 Mbs settings.

Dirty mode (single payload mode only)

See “Dirty transmitter”.

Dirty params table

The dirty parameters table is used in sensitivity tests for all measurement groups.

Dirty transmitter

Turns the dirty transmitter on or off.

Edit dirty table

Provides access to the dirty transmitter settings table. The table can be edited to permit testing of the EUT with user-defined impairments. Increased impairments may be required during design verification or stress testing.

EUT power level

Select "EUT power level" and press **Sel** to toggle between "MAX", "MIN", and "MAX & MIN". The "MAX" and "MIN" settings set the EUT to its maximum or minimum power respectively. If "MAX & MIN" is selected, the EUT is set initially to its maximum power and testing is then repeated after resetting the EUT to its minimum power.

Frequency

The frequency or channel on which measurements are performed.

Hopping

Hopping can be set to ON or OFF. If set to ON the user can then select from three further hopping test mode settings as defined below.

Hopping test mode

Three hopping test mode settings are available: Defined, All, and Any

Defined: The MT8852B triggers a measurement only when the link hops to one of the frequencies defined on the LOW, MEDIUM and HIGH set up page. The number of packets measured at each frequency is set by the user in the "Number of packets" field. This is the test method described in the *Bluetooth* RF Test Specification.

All: The MT8852B measures the power at each of the 79 frequencies in the *Bluetooth* channel structure. The measurement continues until the number of packets measured at each frequency matches the value set by the user in the "Number of packets" field.

Any: The MT8852B measures the power at the next frequency that the link hops to after the previous power measurement has been completed. The total number of packets measured is set by the user in the "Number of packets" field. This is typically the shortest of the three options as there is no requirement to measure a large number of packets at specified frequencies.

Low, medium, and high

The LOW, MEDIUM and HIGH frequencies relate to the default frequencies specified in the *Bluetooth* RF test specification.

Measurement delay

The time delay between the step command and the time that measurement is commenced. This allows the EUT transmitter power to settle before the MT8852B starts to measure power.

Minimum sensitivity check

Set "Min sensitivity check" to True or False. When "TRUE", the MT8852B sends decrement commands to set the EUT to its minimum transmitter power level. Measurements are then performed with the EUT transmitting at minimum power. When "FALSE", the MT8852B measures relative power only with the EUT transmitting at maximum power. When "TRUE" if the EUT supports power control, the MT8852B also measures relative power at the EUT minimum power setting.

Minimum test power

Use the keypad to enter a value for the minimum EUT power. When a power below this value is received by the MT8852B it will start sending increment power commands, even if it has not received a minimum power command from the EUT. This prevents the EUT from disconnecting from the MT8852B by transmitting at a level below the receiver sensitivity.

Number of bits

The number of bits sent by the MT8852B for BER measurements. The MT8852B automatically calculates the number of packets that will be required to send the number of bits.

Number of blocks

When tests require the MT8852B to perform measurement across the length of the payload, the payload is divided into blocks for analysis. This setting defines the number of blocks to be included in the measurement.

Number of packets

Used to specify the number of packets measured at each of the "LOW", "MEDIUM" and "HIGH" frequencies.

Packets per step

This is the number of EUT packets measured at each power control step.

Packet type

Select the required packet type: Longest, DH1, DH3, or DH5. Longest sets the packet type to the longest length that the EUT supports as reported by the EUT supported features.

Payload (single payload mode only)

Select from PRBS9, 11110000, or 10101010. Not available in standard mode as configured automatically from other test conditions.

Payload pkt count

This setting allows the user to specify whether the count of the number of packets is based on the transmitted or received values. The settings are detailed below.

Transmitted: The measurement is based on the number of transmitted bits. Due to lost packets, this setting may result in failure to comply exactly with the *Bluetooth* test specification that requires that the test should be conducted for at least 1.6 million bits.

Received: The measurement is based on the number of bits actually received. This setting will force the MT8852B to continue testing until 1.6 million bits have been measured.

Test control (single payload mode only)

See "Test type".

Test Tx Power

This is the output power used to transmit packets for the sensitivity and maximum input measurements. Management packets are always sent at the script power level.

Test type

This setting is used to switch between "Loopback" and "Tx mode".

In Loopback mode, the MT8852B sends a packet to the EUT. The EUT loops back the packet at baseband level and retransmits exactly the same payload data to the MT8852B.

In Tx mode, the EUT is configured to send a fully formed packet to the MT8852B each time it receives a Poll packet.

Threshold bit count

This setting is used to define the number of bits in the first stage pass/fail decision. If a pass is registered, the test stops. If a fail is registered, the test continues with a greater number of bits being measured. See "Total test bit count".

Toggle payload

Select "Toggle Payload" and select either "Continuous" or "Once" as detailed below.

Continuous: This is the default setting in which, to comply with the RF test specification, the payload is changed after each packet measured.

Once: This setting reduces the time required to complete the test. The payload is changed only once per measurement stage. The payload is changed after the selected number of packets has been measured with the first payload and the selected number of packets is then measured with the second payload.

Glossary

Total test bit count

If the first stage BER fails, this value defines the second stage number of bits to be tested.

Tx power

See “Test Tx Power”.

Appendix C — Preset Values

C-1 Preset Values

Table C-1. Default Values

Item	Default Setting
AFH	Off
Authentication	Disabled
Channel pattern	Standard (79 channels)
Display contrast	5
Key click	ON
Entry error beep	OFF
Display frequency as	MHz
End paging after	10 seconds
EUR reporting rate for AFH	1 second
EUT address source	Inquiry
EUT reporting for AFH	Off
EUT RS232 Baud rate	57600
RS232 Parity	None
RS232 Data length	8 bits
RS232 Stop bits	1 bit
RS232 Handshaking	RTS/CTS
GPIB address	Not changed
Inquiry scan	OFF
Inquiry set up	1 response, 20 seconds, common name ON
LE Packet Length Mode	Manual
LE Packet Length	37
Link status	Will perform disconnect, if connected
Link timeout	10 seconds
Loop continuously	ON
Loop count	Continuous
Loop stop on test fail	OFF
Min Active channels for AFH	20
Modulation index	0.32
Path offset	Not changed
Payload pkt count	Transmitted
Range hold	Auto

Preset Values

Table C-1. Default Values

Item	Default Setting
Read EUT name on connection	OFF
RS232 baud rate	Not changed
RS232 mode	EXT COMMS
Script	QUICKTEST
Script mode	Standard
Script set up conditions	Not changed
Set EUT max pwr on connection	ON
Signal generator mode	OFF
Test pause	On
Test set up conditions	Not changed
TX power level	Not changed

Appendix D — Messages

D-1 Error Messages

The vast majority of the top line error messages are self-explanatory and the required course of action will be immediately apparent. The table below lists the messages for which a note of explanation may be required.

Table D-1. Error Messages

Message	Meaning
AFH option not installed	Displays when the AFH enable is sent to a non AFH option enabled unit.
Audio option not installed	Displays when a SCO connection request is sent to a non SCO option enabled unit.
Authentication failure	The EUT has requested Authentication from the MT8852B in order to complete a connection. Set the "Authentication" item under Equipment Under Test to "Enabled".
BLE only option installed	An attempt to select Basic Rate tests has been made on an BLE only MT8852B
BLE option not installed	Displays when a BLE test RUN request is sent to a non BLE option enabled unit
BLE DLE option not installed	Displays when an attempt is made to use low energy data length extension functions when the option is not installed.
Communication timeout	The EUT has not acknowledged a communication from the MT8852B and the MT8852B has run out of retries.
Connection ended by local host	The MT8852B ended the connection with the EUT.
Connection ended, low resource	The reason the EUT ended the connection was reported as due to low resources.
Connection failed	The ACL or SCO connection failed to be established.
Connection lost	The EUT has disconnected with an unrecognized error/reason code.
Connection lost, timed out	The MT8852B has not received any communication from the EUT for a defined period of time. The default time is 10 seconds. It can be set under Config \ MT8852B \ RXTX settings "Link timeout".
Connection made (n:time)	When option 15 is enabled, the connection number and time are in the following format. Connection made (n:time) n: Connection number time: Connection time in ms

Error Messages

Table D-1. Error Messages

Message	Meaning
Core busy, try again	When driving the MT8852B via GPIB using the auxiliary command, additional rules have to be applied as listed below. A. After a CONNECT command, check the connection complete bit (CON) of the INS register or the ERRLST output for the connection failure, before sending another command. B. After the INQUIRY command, check that the inquiry is complete using status bit (INQ) of the INS register before sending any other commands except INQCANCEL command.
DSP not communicating	Measurement processor is no longer communicating with the main processor.
EDR 8PSK Modulation not found	The tester was expecting an 8-DPSK modulated EDR packet but the decoded packet type field does not indicate an 8-DPSK packet.
EDR Expected length mismatch	The tester was expecting a payload length of a given number of bytes, but the decoded payload field does not give the same result.
EDR Insufficient blocks	Insufficient data blocks detected in the EDR portion for packet analysis to occur.
EDR $\pi/4$ Modulation not found	The tester was expecting a $\pi/4$ -DQPSK modulated EDR packet but the decoded packet type field does not indicate a $\pi/4$ -DQPSK packet.
EDR Unknown packet type	Could not decode packet type.
EDR mod. mode not specified	Modulation mode not specified.
EDR option not installed	Displays when an EDR test RUN is requested or when trying to select EDR tests on a non EDR option enabled unit.
EDR sync word exceeds limits	The EDR synchronization word has been detected outside of its expected location.
EUT RS232 not available	The MT8852B was requested to update the EUT settings via the EUT control RS232 interface when the <i>Bluetooth</i> address source was not set to RS232.
EUT Unsupported feature	The EUT does not support the feature that the MT8852B is attempting to use.
EUT does not support BLE	A BLE test RUN was attempted on a device that does not support BLE.
EUT not reached Max Power	The EUT was requested to go to maximum Tx power and a MAX power LMP has not been received.
EUT not reached Min Power	The EUT was requested to go to minimum Tx power and a MIN power LMP has not been received.

Table D-1. Error Messages

Message	Meaning
EUT test mode rejected	On completion of the ACL connection, the MT8852B sends an activate test mode command to the EUT. The EUT must have been preconfigured to accept this command. If the EUT has not been initialized to go into test mode, this error message is shown. Only Null packet mode testing can be performed in this condition.
Error decoding the packet type	Decoded packet type does not match the correct type.
Error finding packet start	There was no packet burst found.
Error locating EDR sync word	The EDR synchronization word could not be located. The location of the EDR synchronization word is incorrect or the EDR synchronization word is incorrect/corrupted.
Error locating GFSK sync word	The GFSK synchronization word could not be located. A common cause is the access code is set incorrectly or is corrupted, or the location of the GFSK synchronization word is incorrect.
Error!< Already in RUN	The RUN command has been sent to the MT8852B but the MT8852B is already RUNning a test/script.
Error!< BLE Addr Srce Invalid	The EUT address source is set to Inquiry or Manual and BLE test cases are also selected. For BLE test cases, the valid EUT address sources are RS232, USB or BLE2WIRE.
Error!< BT Addr Srce Invalid	The EUT address source is set to BLE2WIRE and BR/EDR test cases are also selected. BLE2WIRE is only valid for BLE test cases.
Error!< EUT in Test Mode	The MT8852B has sent the Enable Test mode command to the EUT but the EUT is already in test mode. The enable test mode command needs to be sent only once to a EUT
Error!< External HCI	The MT8852B has been configured to be controlled by an external device through its rear panel RS232 HCI interface. To return to normal operating mode, press CONFIG\MT8852B\System interfaces – and set “RS232 mode” to EXT COMMS.
Error!< GPIB test config	When an instrument is in single test mode and configuration change or data read is attempted for another test, this message will appear.
Error!< In chan display mode	The MT8852B is in channel display mode but a frequency command was sent to the MT8852B. When in channel display mode, only channel commands are valid.
Error!< Invalid BLE Frequency	An invalid BLE frequency was sent during the configuration of a BLE test case. BLE frequencies are spaced 2MHz apart.
Error!< Num packets not even	For the BLE PER test case, an odd number of packets have been sent to the MT8852B. For this test case, the number of packets must be an even number.

Error Messages

Table D-1. Error Messages

Message	Meaning
Error!< Out of range value	A test case configuration parameter was sent to the MT8852B that is outside of the valid parameter range. Check the parameters being sent to the MT8852B. Refer to the measurement setup pages of the manual for valid ranges.
Error!< Password required	The script that is being edited is locked by a password. Enter the password to edit the script.
Error!< Slave mode	The MT8852B is in 'Make me a EUT mode' and an incompatible request has been sent to the MT8852B. Preset or Restart the MT8852B to reset the state of the MT8852B.
Error!< in calibration mode	This message is output when trying to perform a test run whilst the instrument is in calibration mode.
Error!< locked script	It is not possible to edit a script that has been locked by another user. To lock and unlock scripts, press Scpt/Test, move the pointer to the script number and press the List soft key. The status of all scripts is then shown and can be changed using the soft keys.
Error!< non-editable script	Scripts 1 and 2 are factory set to represent common test requirements and cannot be altered by the user. To define your own script settings use scripts 3 to 10.
External HCI interface	The instrument's <i>Bluetooth</i> core is now driven only by the RS232 connection on the MT8852B back panel using standard HCI commands.
GFSK sync word exceeds limits	The GFSK synchronization word has been detected outside of its expected location.
Hardware failure	The MT8852B has reported a Hardware error. Restart the MT8852B.
Host timeout	The EUT has not responded to a connection request before the accept connection timer has expired.
IQ Modem DAC Saturation	The MT8852B IQ modem has reported an error. Check the EUT transmit power level and re-RUN the test.
Incorrect packet length	The packet received from the EUT is not the full length of a standard DH1, DH3 or DH5 packet. It is therefore not suitable for measurements.
Internal sync error, ET busy	The MT8852B has reported a synchronization error. Restart the MT8852B.
Invalid Air code	When attempting to establish a SCO connection with the EUT, the MT8852B air code must correspond to the air code used by the EUT. Press Config \ MT8852B \ Audio and set the air code format to match that of the EUT, before attempting a SCO connection.
Invalid LMP parameters	The EUT rejected the LMP due to the parameters not being compatible with its present state.

Table D-1. Error Messages

Message	Meaning
Invalid Payload	The payload has been corrupted and cannot be used for measurements. Typically this would be an error in the 10101010 or 11110000 bit structure.
Invalid packet	MT8852B did not receive the test packet expected
Invalid packet type	Warning message from the measurement processor that the packet received was not the type it had been requested to measure.
LMP timeout (TC: xx HOP: ON or OFF)	The MT8852B has sent an LMP test control to the EUT and the EUT has not responded with an LMP accepted message. "xx" represents the scenario number as defined in the <i>Bluetooth</i> test mode specification. The following numbers are used: 0: Pause Test Mode 3: Transmitter test – 1010 pattern 4: Transmitter test – PRBS9 5: Closed loop back – ACL packets 7: ACL packets without whitening 9: Transmitter test – 11110000 pattern
LMP timeout (test pause)	The EUT has not sent an LMP accepted message to the Test Pause message sent by the MT8852B.
Local/Remote BDADDR clash	The MT8852B and the EUT have the same Bluetooth address. Change the address of the EUT.
Loop: current test failed	The MT8852B is running a test or script in loop mode with the "loop stop on fail" option ON. A measurement has failed causing the test or script to stop running.
Max number of SCO conns	It is not possible to set up more than 3 SCO connections.
Max number of connections	Maximum number of ACL connections.
Max power exceeded, level > 0	A warning that the power level selected including any offset is outside of the specification of the MT8852B transmitter range. If the TX level and the offset is > 0dBm then this warning is displayed.
No EUT address	The EUT address source is set to manual but no address has been entered. Set an address manually .
No USB device connected	The EUT address source is set to USB when a test or script is RUN but there is no USB device connected to the EUT control port of the MT8852B. Connect a USB device to continue.
No connection made, timed out	When attempting to establish a connection, the process failed due to a timeout.
No packet detected	Warning from the measurement processor. A request to measure has been received and no packets have been detected.

Error Messages

Table D-1. Error Messages

Message	Meaning
No payload detected	The packets looped back by the EUT appear to have no payload. The EUT may be looping back Null packets only.
No sync word correlation	The MT8852B is unable to correlate to the EUT transmitted packets header.
No test control End event	The end of the test sequence has not been received.
No tests selected!	The RUN button has been pressed or RUN command has been sent to the MT8852B and there are no test cases selected in the script. Select a test case before RUNNING a script.
Non <i>Bluetooth</i> USB device	The USB device attached is not a <i>Bluetooth</i> device.
Not enough Measurements	The MT8852B did not receive sufficient measurable packets to complete the selected test.
Null packets mode	The MT8852B is configured to make simple measurements on Null packets transmitted by the EUT. To return to standard <i>Bluetooth</i> operating modes press Scpt/Test , move the pointer to the script number and press the setup soft key. Set "Script mode" to Standard.
Operation not allowed	When changing EUT audio settings, an ACL connection must be established first.
Option already enabled	An option code for a MT8852B option has been entered but the option is already installed.
Option not enabled	The attempted action cannot be performed under the current configuration.
Option not supported	The option requested cannot be supported with reduced function option installed
Packet type change rejected	The EUT has rejected the packet type change request. Check the EUT supports the packet type selected.
Pairing not allowed	The pairing attempt was rejected by the EUT. Check if the EUT has authentication enabled.
Repeated attempts	The EUT reports that too little time has elapsed since an unsuccessful attempted to connect, authenticate or pair.
Role change not allowed	During the connection process the EUT has attempted to become the piconet master. This is not allowed by the MT8852B which must always remain the piconet master. Reconfigure the EUT such that it does not attempt to become a master on connection.
Signal Over Range	The EUT power is greater than the input range of the MT8852B. The maximum input power for measurement is +23 dBm.
Signal Under Range	The EUT power is below the input range of the MT8852B. The minimum input power to maintain a link is -55 dBm, and for power measurements is -30 dBm.

Table D-1. Error Messages

Message	Meaning
Single Payload mode	MT8852B has been configured to test an EUT by sending one test control at a time. This limits the speed with which a range of measurements can be made, but can improve reliability with EUTs that do not yet have a robust implementation of test mode signalling. To return to the standard <i>Bluetooth</i> operating mode press Scpt/Test, move the pointer to the script number and press the setup soft key. Set "Script mode" to Standard.
Synchronization error	The EUT control RS232 control of the EUT has received an illegal sequence.
System auto-ranging	The measurement system unexpectedly required a range change.
Test stopping	A test stop has been requested and the test is in the process of stopping.
USB device attached	A USB device has been attached and is ready.
USB device removed	A USB device has been removed.
Unknown HCI command	When under External HCI control, an unrecognized HCI command has been received.
Unsupported feature	The EUT has been requested to use a feature it does not support.

D-2 Error Codes

A detailed explanation of each error code is given in the *Bluetooth* specification Part H:1, Host Controller Interface, section 6.2.

Bluetooth Specification 4.0 Devices

Table D-2. Error Codes

Error	Description
0X01	Unknown HCI Command
0X02	Unknown Connection Identifier
0X03	Hardware Failure
0X04	Page Timeout
0X05	Authentication Failure
0X06	PIN or key Missing
0X07	Memory Capacity Exceeded
0X08	Connection Timeout
0X09	Connection Limit Exceeded
0X0A	Synchronous Connection Limit to a Device Exceeded
0X0B	ACL Connection Already Exists
0X0C	Command Disallowed
0X0D	Connection Rejected due to Limited Resources
0X0E	Connection Rejected due to Security Reasons
0X0F	Connection Rejected due to Unacceptable BD_ADDR
0X10	Connection Accept Timeout Exceeded
0X11	Unsupported Feature or Parameter Value
0X12	Invalid HCI Command Parameters
0X13	Remote User Terminated Connection
0X14	Remote Device Terminated Connection due to Low Resources
0X15	Remote Device Terminated Connection due to Power Off
0X16	Connection Terminated by Local Host
0X17	Repeated Attempts
0X18	Pairing not Allowed
0X19	Unknown LMP PDU
0X1A	Unsupported Remote Feature / Unsupported LMP Feature
0X1B	SCO Offset Rejected
0X1C	SCO Interval Rejected
0X1D	SCO Air Mode Rejected
0X1E	Invalid LMP Parameters

Table D-2. Error Codes

Error	Description
0X1F	Unspecified Error
0X20	Unsupported LMP Parameter Value
0X21	Role Change Not Allowed
0X22	LMP Response Timeout / LL Response Timeout
0X23	LMP Error Transaction Collision
0X24	LMP PDU Not Allowed
0X25	Encryption Mode Not Acceptable
0X26	Link Key Can Not be Changed
0X27	Requested QoS Not Supported
0X28	Instant Passed
0X29	Pairing with Unit Key Not Supported
0x2A	Different Transaction Collision
0X2C	QoS Unacceptable Parameter
0X2D	QoS Rejected
0X2E	Channel Assessment Not Supported
0X2F	Insufficient Security
0X30	Parameter out of Mandatory Range
0X32	Role Switch Pending
0X34	Reserved Slot Violation
0X35	Role Switch Failed
0x36	Extended Inquiry Response Too Large
0X37	Simple Pairing Not Supported By Host
0X38	Host Busy-pairing
0X39	Connection Rejected Due To No Suitable Channel Found
0X3A	Controller Busy
0X3B	Unacceptable Connection Interval
0X3C	Directed Advertising Timeout
0X3D	Connection Terminated Due To MIC Failure
0X3E	Connection Failed To Be Established
0x3F	MAC Connection Failed

Internal HCI and Communication List of Error Codes**Table D-3.** Error Codes

Error	Description
0x51	Message from state controller unknown
0x52	Command from state controller unknown
0x53	Failed to create piconet
0x54	Disconnect returned fail
0x55	Failed to communicate to HCI comm. Port
0x56	Timeout on reply from BBP HCI
0x57	HCI link returned fail
0x58	Missing event in protocol
0x59	Timed out waiting to receive the required measurements
0x5A	Did not receive a TX/LB end event
0x5B	The EUT has not been put into test mode
0x5C	Core returned a hardware error event
0x5D	HCI command not implemented
0x5E	SYNC or invalid packet length error
0x5F	DSP not communicating
0x60	Max power not reached
0x61	Min power not reached

Appendix E — Bit and Frame Error Rates

E-1 Bit and Frame Error Rates

The flow diagram below illustrates the decision processing performed by the MT8852B in determining bit and frame error rates.

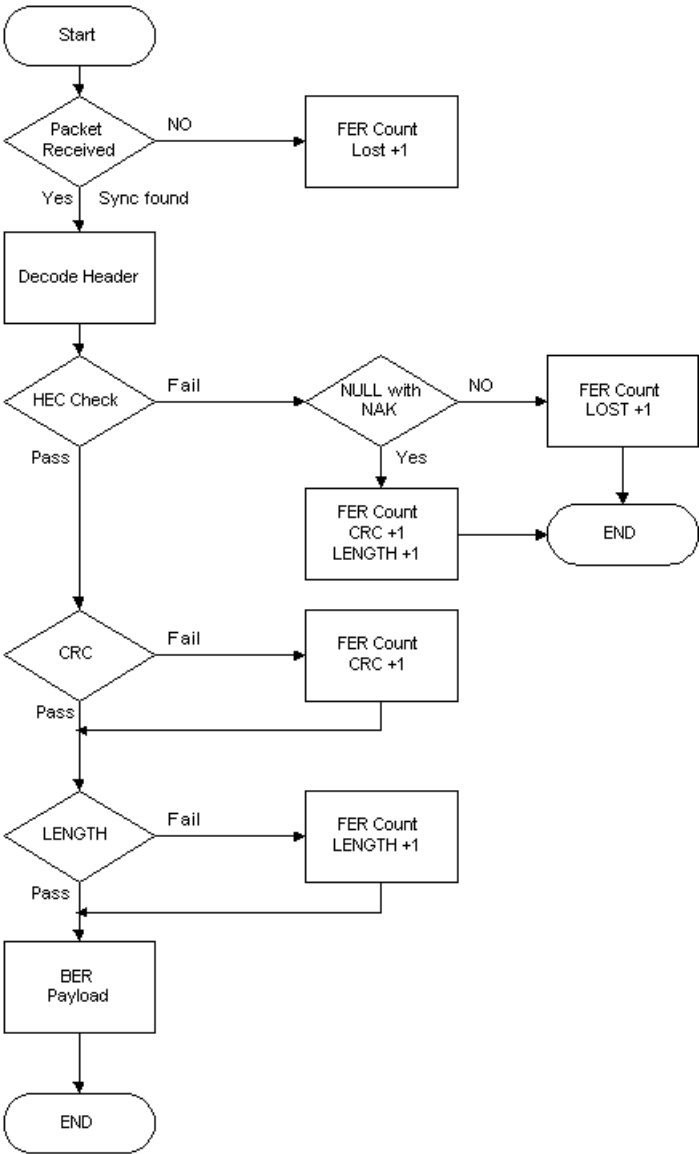

Figure E-1. Bit and Frame Error Rates

Appendix F — Terminology Glossary

F-1 Terminology Glossary

Table F-1. Commonly Used Acronyms and Terminology

Term	Meaning
2LE	<i>Bluetooth</i> Low Energy 2 Mbps
$\pi/4$ -DQPSK	pi/4 Differential Quaternary Phase Shift Keying
8DPSK	8 Phase Differential Phase Shift Keying
ACL	Asynchronous Connectionless
AFH	Adaptive Frequency Hopping
BER	Bit Error Rate
BLE	<i>Bluetooth</i> Low Energy
BLR	<i>Bluetooth</i> Long Range (LE Coded). A “2” or “8” suffix indicates the coding scheme.
BT	<i>Bluetooth</i>
CODEC	Coder-Decoder
CRC	Cyclic Redundancy Check
CVSD	Continuous Variable Slope Delta Modulation
CW	Continuous wave
DEVM	Differential Error Vector Magnitude
EDR	Enhanced Data Rate
eSCO	extended Synchronous Connection-oriented
EUT	Equipment Under Test
FEC	Forward Error Correction
FER	Frame Error Rate
FPGA	Field Programmable Gate Array
FSK	Frequency Shift Keying
FTDI	Future Technology Devices International
GFSK	Gaussian Frequency Shift Keying
GPIO	General Purpose Interface Bus
HCI	Host Controller Interface
HEC	Header-Error-Check
HV1,2,3	High Quality Voice
IEEE	Institute of Electronic and Electrical Engineering
ISM	Industrial, Scientific, Medical
LAN	Local Area Network

Terminology Glossary

Table F-1. Commonly Used Acronyms and Terminology

Term	Meaning
LE	Low Energy
LE Coded	Low Energy Coded (Also known as <i>Bluetooth</i> Long Range, BLR)
LM	Link Manager
LMP	Link Manager Protocol
MDR	Maximum Difference Relative
MLAS	Master's Local Assessment Scheme
NACK	Negative Acknowledgement Message
PSK	Phase Shift Keying
Pattern Mapping	A step in the encoding process of BLR (LE Encoded) packets.
POST	Power-On Self Test
PRBS	Pseudo-Random Bit Sequence or Pseudo-Random Binary Sequence
RF	Radio Frequency
RMD	Repeat Maximum Difference
RS232	Serial communications interface defined by EIA
RSSI	Received Signal Strength Indication
Rx	Receiver
SCO	Synchronous Connection Oriented
SIG	Special Interest Group
SLAS	Slave's Local Assessment Scheme
STE	Symbol Timing Error
TCP/IP	Transport Control Protocol/Internet Protocol
Tx	Transmit
ULP	Ultra Low Power. Now known as <i>Bluetooth</i> low energy.
USB	Universal Serial Bus
Wibree	Now known as <i>Bluetooth</i> low energy.
WLAN	Wireless Local Area Network

Appendix G — Connector Care and Handling

Follow the precautions listed below when handling or connecting cables. Complying with these precautions will guarantee longer component life and less equipment down time due to connector or device failure.

G-1 Pin Depth Mating Connectors

Destructive pin depth of mating connectors is the major cause of failure in the field. When an RF component is mated with a connector having a destructive pin depth, damage will usually occur to the RF component connector. A destructive pin depth is one that is too long in respect to the reference plane of the connector (see figure below).

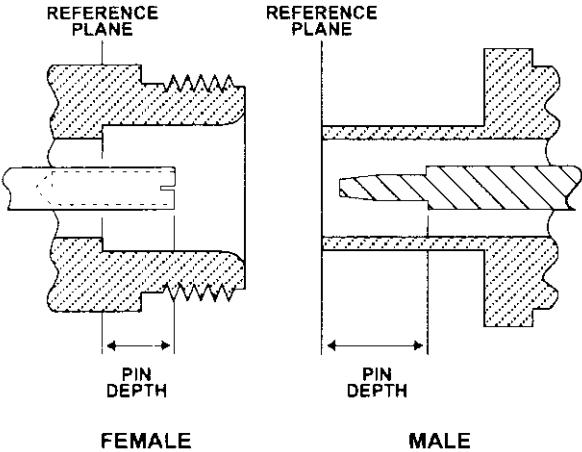

Figure G-1. N Connector Pin Depth Definition

Torquing Connectors

The center pin of a precision RF component connector has a precision tolerance. The mating connectors of various RF components may not be precision types. Consequently, the center pins of these devices may not have the proper pin depth. The pin depth of EUT connectors should be measured to assure compatibility before attempting to mate them with Power Sensor connectors. An Anritsu Pin Depth Gauge equivalent can be used for this purpose.

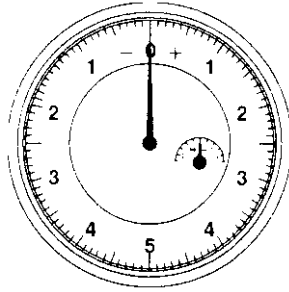

Figure G-2. Pin Depth Gauge

If the measured connector is out of tolerance in the "+" region, the center pin is too long (see Allowable EUT connector pin depth table below). Mating under this condition will likely damage the precision RF component connector. If the test device connector measures out of tolerance in the "-" region, the center pin is too short. This should not cause damage, but it will result in a poor connection and a consequent degradation in performance.

EUT Connector Type	Anritsu Gauging Set Model	Pin Depth (inches)	Pin Depth Gauge Reading
N - Male	01-163	207 -0.000	207 +0.000
N - Female		+0.030	-0.030
WSMA - Male	01-162	-0.000	Same as pin depth
WSMA - Female		-0.010	
3.5 mm - Female		-0.010	

G-2 Torquing Connectors

Over torquing connectors is destructive; it may damage the connector center pin. Finger-tight is usually sufficient for Type N connectors. Always use a connector torque wrench (8 inch-pounds) when tightening WSMA, K or V type connectors. Never use pliers to tighten connectors.

G-3 Mechanical Shock

Precision connectors are designed to withstand years of normal bench handling. However, do not drop or otherwise treat them roughly. Mechanical shock will significantly reduce their service life.

G-4 Cleaning Connectors

The precise geometry that makes possible the RF component's high performance can easily be disturbed by dirt and other contamination adhering to the connector interfaces. When not in use, keep the connectors covered.

To clean the connector interfaces, use a clean cotton swab that has been dampened with denatured alcohol.

Note

Most cotton swabs are too large to fit in the smaller connector types. In these cases, it is necessary to peel off most of the cotton and then twist the remaining cotton tight. Be sure that the remaining cotton does not get stuck in the connector. Cotton swabs of the appropriate size can be purchased through a medical laboratory-type supply center.

The following are some important tips on cleaning connectors:

- Use only denatured alcohol as a cleaning solvent
- Do not use excessive amounts of alcohol as prolonged drying of the connector may be required
- Never put lateral pressure on the center pin of the connector
- If installed, do not disturb the Teflon washer on the center conductor pin
- Verify that no cotton or other foreign material remains in the connector after cleaning it
- If available, use compressed air to remove foreign particles and to dry the connector
- After cleaning, verify that the center pin has not been bent or damaged.

Appendix H — Low Energy Packet Structure

H-1 Low Energy Packet Structure

The packet formats used in all low energy tests are shown in the figures below.

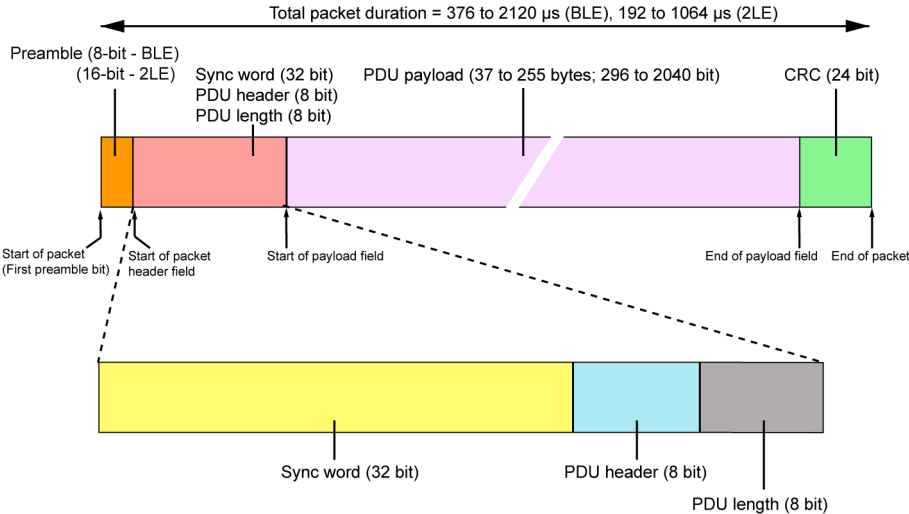

Figure H-1. Low Energy Test Packet Structure - BLE and 2LE

Low Energy Packet Structure

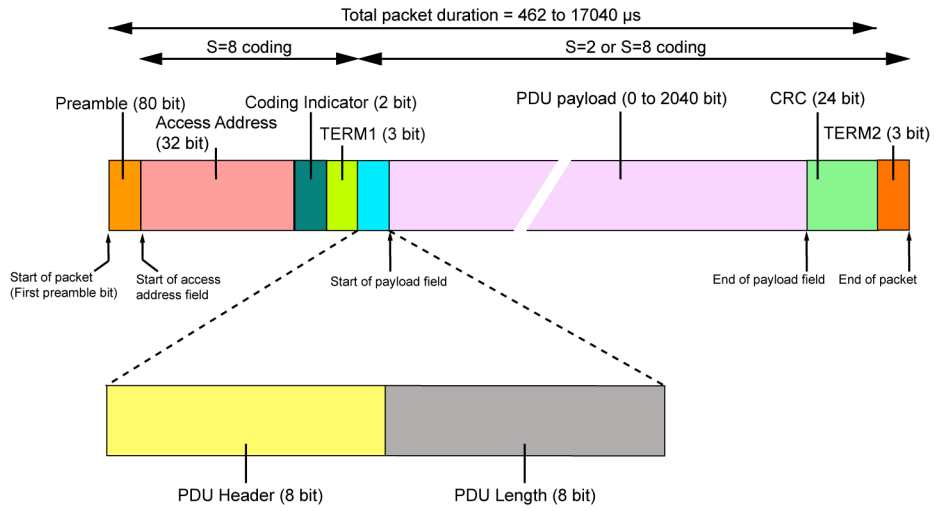

Figure H-2. Low Energy Test Packet Structure - BLR

Index

- A**
- accessories 1-4
 - adaptive frequency hopping (AFH) .. 15-1
 - AFH 15-1
 - audio 15-8
 - channel vs time 15-5
 - configuration 15-5
 - FER vs time 15-7
 - implementation on MT8852B ... 15-4
 - overview 15-1
 - processing 15-2
 - AFH measurement setup 11-13
 - all scripts setup 5-11, 11-18
 - audio measurements 11-9, 14-1
 - with AFH 14-7
 - authentication setup 11-16
- B**
- Basic Rate 4-5
 - Basic Rate tests 7-4
 - BER E-1
 - bit error rates E-1
 - BLE packet generator 11-11
 - BlueSuite Pro3 1-6
 - Bluetooth
 - address acquisition 6-1
 - connection 6-1
 - overview 2-1
 - qualification 2-1
 - RF tests 2-3
 - SIG 2-1
 - specification 2-2
 - test mode 2-2
 - Bluetooth interferer 12-1
- C**
- cable connection 4-9
 - carrier drift test
 - Basic Rate 7-13, 9-8
 - low energy 7-44
 - combitest 1-5
 - configuring tests 5-5
 - connection control 11-19
 - connector care G-1
 - connector handling G-1
 - continuous wave 11-9
 - CW measurements 11-9, 13-1
- D**
- data entry 4-9
 - display and sound 11-6
 - display icons 4-6
 - display preferences 5-12
- E**
- EDR 4-5
 - EDR BER floor test 7-37
 - EDR carrier and modulation test 7-29
 - EDR differential phase test 7-33
 - EDR max input test 7-39
 - EDR relative Tx power test 7-27
 - EDR sensitivity test 7-35
 - enhanced data rate 4-5
 - enhanced data rate tests 7-27
 - enhanced power control test 7-8
 - error codes D-8
 - EUT
 - address 6-1
 - preparing for connection 6-1
 - receive path 14-5
 - remote power control 11-20
 - transmit path 14-5
- F**
- feature control 11-21
 - FER E-1
 - frame error rates E-1
 - front panel 4-1
- G**
- glossary of terms F-1

H

hard keys 4-4

I

icons 4-6

identity 11-5

initial carrier test 7-11, 9-6

inquiry 6-2

inquiry/paging setup 11-15

IQ data output 16-1

L

limits 7-3

low energy

 definition 4-5

 packet structure H-1

 tests 7-41

M

make me an EUT 11-19

manual

 about 1-1

 associated documentation 1-2

 comments on 1-1

 conventions 1-2

master devices 2-1

maximum input power test

 Basic Rate 7-24

 low energy 7-54

messages D-1

modulation index test

 Basic Rate 7-21

 low energy 7-47

MT8852B

 configuration 4-9

 description 1-3

 display and sound 11-6

 features 1-4

 front panel 4-1

 identity 11-5

 messages D-1

 model types 1-3

 operating environment 3-1

 power on 3-3

 power requirements 3-1

 preset values C-1

 rear panel 4-8

 software upgrade 11-20

 specification A-1

 unpacking 3-2

multi slot sensitivity

 basis rate 7-18

N

null packet mode

 definition 9-1

 selecting 9-1

 supported tests 9-1

O

operating environment 3-1

options 1-4

output power test

 Basic Rate 7-4

 low energy 7-41

over-air connection 4-10

P

package contents 3-2

packet generator 11-11

password 5-15

PER integrity test 7-52

power control test 7-6, 9-4

power on 3-3

power requirements 3-1

preset values C-1

R	
rear panel	4-8
rear panel outputs	11-10
remote loopback	14-1
RS232	6-4
RS232 setup	11-15
running single tests	10-1
Rx/Tx settings	11-8
S	
safety symbols	
equipment	1-2
manuals	1-2
scripts	
changing password	5-15
configuring	5-3, 5-8, 5-11
definition	5-1
locking	5-14
naming	5-13
selecting	5-2
unlocking	5-15
sensitivity test	7-51
service menu	11-23
shipment	
preparation for	3-3
signal generator	11-11, 12-1
single payload mode	
definition	8-1
supported tests	8-1, 8-3
single sensitivity test	7-15
single test	10-1
slave devices	2-1
soft keys	4-4
software	
release notification	1-2
upgrade	11-20
versions	1-1
specification	A-1
standard mode	
definition	7-1
supported tests	7-1
storage	
preparation for	3-3
supported features	11-14
system interfaces	11-5
T	
technical assistance	17-1
terminology glossary	F-1
test condition definitions	B-1
test groups	4-5, 4-7, 5-3
test limits	5-7
test mode	2-2
tests	
by test group	4-7
configuring	5-5
selecting	5-4
U	
unpacking	3-2
USB	6-5
USB>RS232	6-6
user friendly name	11-14

<p>AUSTRALIA ANRITSU PTY. LTD. Unit 21, 21-35 Ricketts Road Mount Waverley Victoria 3168 Australia Telephone: +61-3-9558-8177 Fax: +61-3-9558-8255</p>	<p>BRAZIL ANRITSU ELETRONICA LTDA. Praça Amadeu Amaral, 27 - 1 Andar 01327-010-Bela Vista-São Paulo-SP Brazil Telephone: +55-11-3283-2511 Fax: +55-11-3288-6940</p>	<p>CANADA ANRITSU ELECTRONICS LTD. 700 Silver Seven Road, Suite 120, Kanata, ON K2V 1C3, Canada Telephone: +1-613-591-2003 Fax: +1-613-591-1006</p>
<p>CHINA ANRITSU SHANGHAI SERVICE CENTER 2F, 8B-2 Section Factory Building, No. 211, Fu Te Rd. (N). China(Shanghai) Pilot Free Trade Zone, Pudong, Shanghai 200131, P.R. China Telephone: +86-21-5868-0228 Fax: +86-10-5868-0558</p>	<p>DENMARK ANRITSU A/S Kay Fiskers Plads 9 2300 Copenhagen S Denmark Telephone: +45-7211-2200 Fax: +45-7211-2210</p>	<p>FINLAND ANRITSU AB Teknobulevardi 3-5 FI-01530 Vantaa Finland Telephone: +358-20-741-8100 Fax: +358-20-741-811</p>
<p>FRANCE Anritsu S.A. 12, Avenue du Québec Bâtiment Ires 1- Silic 612, 91140 VILLEBON SUR YVETTE, France Telephone: +33-1-60-92-15-50 Fax: +33-1-64-46-10-65</p>	<p>GERMANY Anritsu GmbH Nemetschek Haus Konrad-Zuse-Platz 1 81829 München Germany Telephone: +49-89-442308-0 Fax : +49-89-442308-55</p>	<p>HONG KONG ANRITSU COMPANY LTD. Units 1006-7, 10/F, Greenfield Tower, Concordia Plaza, No. 1 Science Museum Road, Tsim Sha Tsui East, Kowloon, Hong Kong Telephone: +852-2301-4980 Fax: +852-2301-3545</p>
<p>INDIA ANRITSU India Private Limited 2nd & 3rd Floor, #837/1, Binnamangla 1st Stage Indiranagar, 100ft Road, Bengaluru - 560038 India Telephone: +91-80-4058-1300 Fax: +91-80-4058-1301</p>	<p>ITALY ANRITSU Sp.A Via Paracelso 4 CD Colleoni Agrate Brianza, 20041 Milano Italy Telephone: +39-39-657021 Fax: +39-39-6056396</p>	<p>JAPAN Anritsu Corporation 5-1-1 Onna, Atsugi-shi, Kanagawa 243-8555 Japan Telephone: +81-46-223-1111 Fax: +81-46-296-1264</p>
<p>KOREA ANRITSU CORPORATION LTD. 5FL, 235 Pangyoeyeok-ro Bundang-gu, Seongnam-si, Gyeonggi-do, 13494 Korea Telephone: +82-31-696-7750 Fax: +82-31-696-7751</p>	<p>SINGAPORE ANRITSU PTE. LTD. 11 Chang Charn Road #04-01, Shriro House Singapore 159640 Telephone: +65-6282-2400 Fax : +65-6282-2533</p>	<p>SWEDEN Anritsu AB Kistagången 20B, 164 40 KISTA, Sweden Telephone: +46-8-534-707-00 Fax: +46-8-534-707-30</p>
<p>TAIWAN ANRITSU CO., LTD. 7F, NO.316, Sec.1 NeiHu Rd., Taipei, 114 Taiwan, R.O.C Telephone: +886-2-8751-1816 Fax: +886-2-8751-1817</p>	<p>UNITED KINGDOM Anritsu EMEA LTD 200 Capability Green, Luton, Bedfordshire, LU1 3LU U.K. Telephone: +44-1582-433200 Fax: +44-1582-731303</p>	<p>UNITED STATES ANRITSU COMPANY 1155 East Collins Blvd., Richardson, TX 75081, U.S.A. Toll Free: 1-800-ANRITSU (267-4878) Telephone: +1-972-644-1777 Fax: +1-972-671-1877</p>

Anritsu



13000-00205



N



Anritsu prints on recycled paper with vegetable soybean oil ink.

<http://www.anritsu.com>