

## Calibration Procedure for 402A Performance Check

Rev. Level	ECN #	Description/Pages Affected
1	9190	Initial Release

	Engineering <i>Bill Zimmermann</i>		Date 2/9/07
	Cal Lab Director <i>Richard Abbott</i>		Date 2/9/07
	Quality Assurance <i>J.B. Nelson</i>		Date 2/9/07
	Date 11/27/06	Title Calibration Procedure for 402A Performance Check	

Rev.	ECN No.	Released for	Doc. Ctrl.	Sheet	No.	Size
1	9190	Production	<i>DLN</i>	Page 1 of 14	CAL-402A	CAL

### 402A Performance Check

Perform this check to validate the operation of the 402A Electrosurgical Analyzer.

#### Equipment Required for Performance Check

- Functional ESU
- Test Leads

#### NOTE

Test leads are supplied with the 402A. They are also available from DNI Nevada. Refer to the current DNI Nevada Price List for availability, part number information, and price.

#### Performance Check Procedure

The initialization process checks automatically for proper performance of the measurement circuitry. To complete the performance check procedure, follow *Power-Up Initialization*, front panel test, and ESU measurement tests and serial communications test.

#### Power up Initialization

Plug the AC power cord into the power entry module on the right hand side of the MODEL 402A.

Turn the unit on and it will sequentially display the following states:

- All segments of the display are on including the decimal places. All LEDS indicators are on.
- The LED next displays the firmware version.
- A series of rapidly changing numbers will be seen on the display. These numbers correspond to the RMS DC conversion offset adjustment. When the adjustment is complete, the LED display will blank.

#### Front Panel Test

1. Push the UP arrow button on the front panel. The LED will display 300. This is the load value in ohms.
2. Cycle the load through its fifteen load settings by repeatedly pressing the UP buttons. When the value reaches 750 ohms, the next value will be 50.
3. Repeat cycling through the load settings using the ***DOWN***.
4. Press the ***MEASUREMENT SELECT*** key on the front panel. The Watts and mA LED will alternately light.

#### Serial Communication Test

A check of the 402A RS-232 port can be completed with an RS-232 terminal. Set the terminal as follows:

Bits per Second (BAUD)	2400
Data Bits	8
Parity	None
Stop Bits	1
Flow Control	None

1. Connect DB9 null modem (female) to 402A RS232 port.
2. Press <ENTER> on terminal. The 402A will send a <?> character to the terminal. This tests the 402A ability to receive and transmit a serial command.

Date	11/27/06		Title Calibration Procedure for 402A Performance Check					
Rev.	ECN No.	Released for	Doc. Ctrl.	Sheet	No.	CAL-402A		Size
1	9190	Production	<i>DLN</i>	Page 2 of 14				CAL

## ESU Measurement Test

An initial check of the 402A can be made with a functional ESU. Use the monopolar cut mode with the output power set to 300 watts.

1. Connect the ESU to the 402A *active* and *dispersive* inputs jacks.
2. Set the ESU output for maximum output and pure cut mode.
3. Adjust the 402A load to the value recommended by the ESU manufacturer. If necessary consult the ESU Operator Manual.
4. Key the ESU and wait for a steady output on the MODEL 402A. Verify that that the expected output of the ESU analyzer agrees with the rated output of the ESU (+/- 15%).
5. Reduce the power by 50 Watts and repeat step 4.
6. Repeat steps 4 and 5 until the operational status of the 402A is confirmed.

## Calibration

Calibration is the set of operations which establish, under specified conditions, the relationship between values indicated by a measuring instrument or measuring system, and the corresponding standard or known values derived from the standard.

## Recommendation

Calibration must be performed at the recommended interval to ensure that the instrument's measurements remain within its specifications. Consult DNI Nevada for the recommended calibration interval.

We recommend that you send your instruments to DNI Nevada for this service. We will install any firmware updates, calibrate it, certify calibration, and return it to you promptly.

Our calibration measurements are traceable to the National Institute of Standards and Technology (NIST). Devices for which these are no NIST Calibration standards are measured against in-house performance standards using accepted test procedures.

## 402A CALIBRATION AND VERIFICATION PROCEDURE

This procedure covers the test, calibration and operation checks of the 402A Electrical Surgical Unit (ESU) Analyzer.

### EQUIPMENT REQUIRED

#### Calibrated Test Equipment

- Fluke 8920A True RMS Meter
- Ross Engineering VD15-8.3-A-LB-TDG-F 1000/1 Capacitive Voltage Divider Calibrated to Fluke 8920A True RMS Meter
- Keithley 196 Multimeter or equivalent

#### Test Equipment – Calibration not required

- Aspen Excalibur ESU or one of equivalent bandwidth – Monitored by calibrated equipment
- Magnelab 3304-005 High Voltage 1:4 Output Transformer - Monitored by calibrated equipment
- Oscilloscope – To verify Oscilloscope Output is working.

Date	11/27/06	Title Calibration Procedure for 402A Performance Check						
Rev.	ECN No.	Released for	Doc. Ctrl.	Sheet	No.	CAL-402A		Size
1	9190	Production	<i>DLW</i>	Page 3 of 14				CAL

## Hand Tools

- Screw Driver, flat tip
- Calibration Alignment Tool

## Accessories

- RS232 Serial Communications Cable (402A connector is 9 pin male)
- 2 each, Calibration Jumpers (Specified after Verification and Scope Out Check)
- Banana Leads
  - 2 – 24"
  - 1 – 6"
- 50 ohm 2 Watt Feed Through Termination (Tektronix PN 011-0049-01) or equivalent

## OVERVIEW and SETUP

### Procedure Familiarization

There are two components to the 402A Calibration Procedure. The first consists of measuring the load resistors. The second component is the calibration of the RMS to DC Converter circuit, which establishes the measurement accuracy of the 402A. This component of the procedure requires the Common Mode Adjustment, which balances the input of the differential amplifier circuit, exciting the ESU with High Voltage, and entering the measured RMS Voltages into the 402A Firmware.

### Equipment Setup



#### WARNING:

Proper equipment setup is important in the calibration of the 402A. ESU signals are typically greater than 5000 Volts Pk-Pk at 1MHz and will cause electrical burns and/or shock if the ESU Active lead comes in contact with personnel. Therefore, all cables should be routed as shown in the figure corresponding to the measurement being performed. As a precaution, connect the ESU output leads to the input of the UUT BEFORE turning the ESU on. Additionally, set the output of the ESU to zero prior to disconnecting the ESU leads during equipment setup changes.

3. Remove anti-static mat from work surface. The 402A calibration should be completed on a clean wood surface.
4. Connect the serial cable from the terminal to the 9 pin serial port located on the right side of the 402A. Terminal settings are listed in the Serial Communication Test paragraph in the 402A Performance Check Section.
5. Setup equipment as shown in Figure 2.1. Turn on UUT and allow sufficient time to warm up.

Date 11/27/06

Title Calibration Procedure for 402A Performance Check

Rev.	ECN No.	Released for	Doc. Ctrl.	Sheet	No.		Size
1	9190	Production	<i>DLV</i>	Page 4 of 14		CAL-402A	CAL

- Verify communication is established between the UUT and host serial port by typing `<DIAG>`. The display will read Diagnostic Mode. Type `<I>`, the display will list the UUT model number and the firmware version. Proceed to Navigation and Peak Detector Leakage Check, to become familiar with the Calibration Procedure serial port interface.

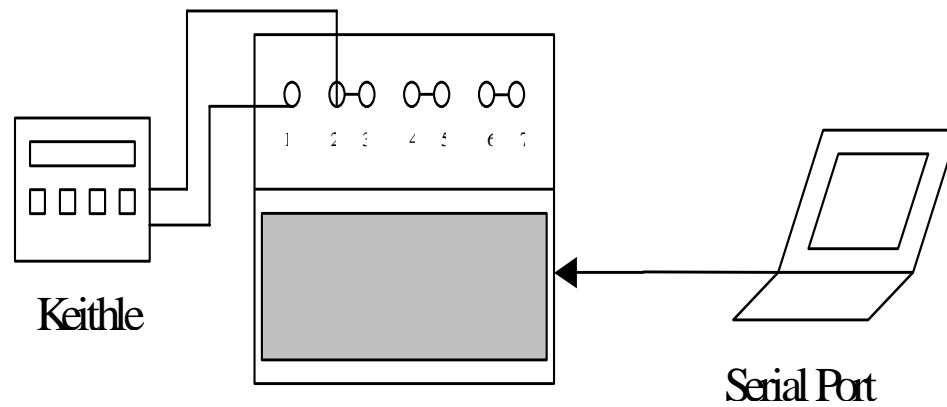

Figure 2.1: Resistance Measurement Equipment Set Up.

#### Navigation and Peak Detector Leakage Check

The calibration procedure requires the technician to enter commands and data via the serial port. To start the data entry, the 402A must be in the CAL mode, which is entered by typing `<CAL>`. Once in the CAL mode, there are 23 individual steps, which can be completed either sequentially starting from Step #1, or non-sequentially should a specific step need to be repeated. The following letter commands allow non-sequential data entry.

- F* -> Forward – goes to the next step
- B* -> Backward – returns to the previous step
- Gn* -> Go To – goes to step number *n*
- Q* -> Quit – quits the calibration

- If the serial port is not in the Diagnostic Mode, enter the diagnostic mode by typing `<DIAG>`
- At the serial port terminal prompt. Type `<A1>`. The message Read ADC Channel 1 = *n* will be displayed where *n* is the positive peak detector voltage. Verify *n* is less than 100.
- Repeat step A for the negative peaks detector by typing `<A2>` and verify *n* is less than 100.
- Leave the diagnostic mode by entering `<q>`.

#### NOTE:

If either peak detector value is 100 or above, the 402A needs to be returned to the service center for repair.

Date 11/27/06		Title Calibration Procedure for 402A Performance Check					
Rev.	ECN No.	Released for	Doc. Ctrl.	Sheet	No.	CAL-402A	Size
1	9190	Production	<i>DLN</i>	Page 5 of 14			CAL

## PROCEDURE

### Measure Resistors

1. Enter the Calibration Mode by typing <CAL>. The default step number is 1.
2. If necessary, short test leads and zero resistance meter. Measure resistance across load. Type in the resistance value to the nearest 0.01 ohm and press <enter>. Upon prompt Entered xx.xx, OK? Press <Y> to accept value or any other key to reject value and repeat measurement. The CAL program will automatically increment to step #2.
3. Complete the following table:

Table 2-1: Calibration Steps

Calibration Step #	Nominal Resistance	Tolerance Range
1	50.00	48 – 52
2	100.00	96 – 104
3	200.00	192 – 208
4	400.00	384 – 416

4. Disconnect ohmmeter.

### Common Mode Adjustment



**WARNING:**

- ① For the following step, a High Voltage signal will be applied to the UUT while the technician is adjusting one pair of tuning capacitors in the input circuit. Use only an insulated calibration adjustment tool and exercise caution during this step.
- ② The 402A Main Board uses a common reference which is NOT referenced to Earth Ground. During this adjustment, the aluminum shielding around the 402A main board will be at a potential referenced to Earth Ground. Touching the shield during this procedure will cause a RF burn on the body part, which contacts it. Therefore, exercise caution while performing this adjustment.

1. Use equipment setup shown in Figure 2.2. Set output of Aspen to 4 Watts Pure Cut and key switch. Interactively adjust C9 and C129 for minimum ADC count on UUT Display and press <Enter>.

**Note:**

Aspen power setting may have to be increased to obtain a suitable display on the UUT.

2. Set output of Aspen to 0 Watts and disconnect from UUT
3. Press <enter> again to increment to Step 7.

Date 11/27/06		Title Calibration Procedure for 402A Performance Check					
Rev.	ECN No.	Released for	Doc. Ctrl.	Sheet	No.	CAL-402A	Size
1	9190	Production	<i>DLV</i>	Page 6 of 14			CAL

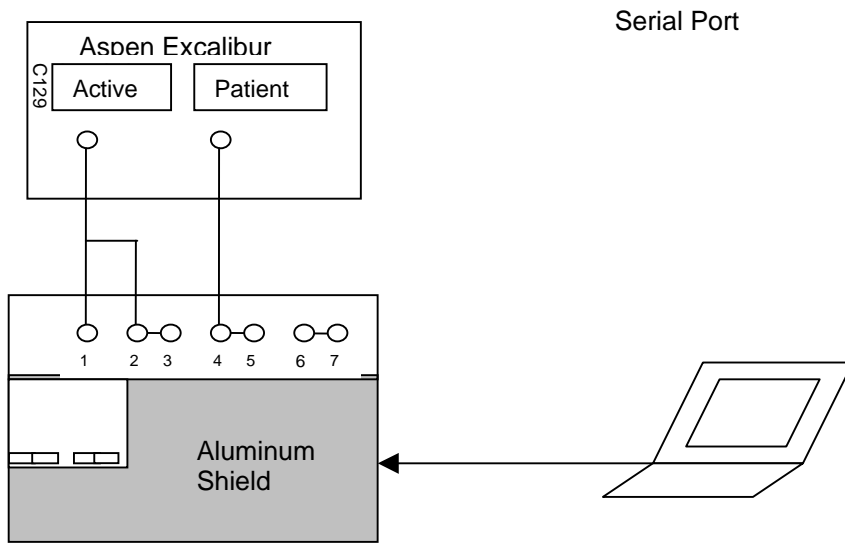

402A ESU Analyzer; Remove cover and set to the side so that display is visible.

Figure 2-.2: Common Mode Adjustment

**RMS Offset Adjustment**

1. Press <enter>. When the offset value has been automatically determined, record the offset value. The Calibration Routine will increment to Calibration Step #8.

**Span and Accuracy Adjustment**

**Note:**  
This step will establish the Accuracy of the 402A. At the end of this chapter there is an example of a test matrix generated using the Aspen Excalibur ESU as the source. If a different source ESU is used, maintain the ADC count displayed on the instrument during calibration within the indicated ranges (200 Counts on the low end of the range nominally and 1000 Counts on the upper end of the range nominally).

**Range 0 to Range 7 Low end and Range 0 to Range 4 High end Adjustment Procedure**

2. Set up equipment as shown in Figure 2.3A.
3. Between each range calibration, verify the 402A display shows an offset within one count of that recorded in the **RMS Offset Adjustment**. During the **Span and Accuracy Adjustment**, repeat the RMS Offset Adjustment any time the value on the 402A display drifts outside the recorded value (+/- 5 counts). After the RMS Offset is re-adjusted, return to the present step using the <Gn> command where n is the step number.
4. Adjust Aspen Excalibur Pure Cut output power as necessary to obtain 500 +/- 50 ADC counts as shown on UUT display. After reading stabilizes (approximately 3 seconds), press <enter> then type in the RMS Volts indicated on the 8920A. Press <enter>. Calibration Routine will automatically increment to step #9.

Date 11/27/06		Title Calibration Procedure for 402A Performance Check					
Rev.	ECN No.	Released for	Doc. Ctrl.	Sheet	No.	CAL-402A	Size
1	9190	Production	<i>DLV</i>	Page 7 of 14			CAL

**Note:**

The value displayed on 8920A is divided by a thousand via the 1000:1 capacitive voltage divider, i.e., if the 8920A displays 8.20 mV RMS, type 8.20 <enter> at the 402A serial port prompt. As the applied RMS voltage increases, the 8920A range automatically increments to the 2 Volt Range, i.e., if the 8920A displays 0.260 V RMS, type 260 <enter> at the 402A serial port prompt.

5. Adjust Aspen Excalibur Pure Cut output power as necessary to obtain 250 +/- 50 ADC counts on UUT display. After reading stabilizes (approximately 3 seconds), press <enter> then type in the RMS Volts indicated on the 8920A. Press <enter>.
6. Complete Table 2-2, adjusting the Aspen Excalibur as necessary to obtain the specified ADC Counts.
7. Set Aspen Excalibur power out to 0 Watts and disconnect ESU leads from UUT.

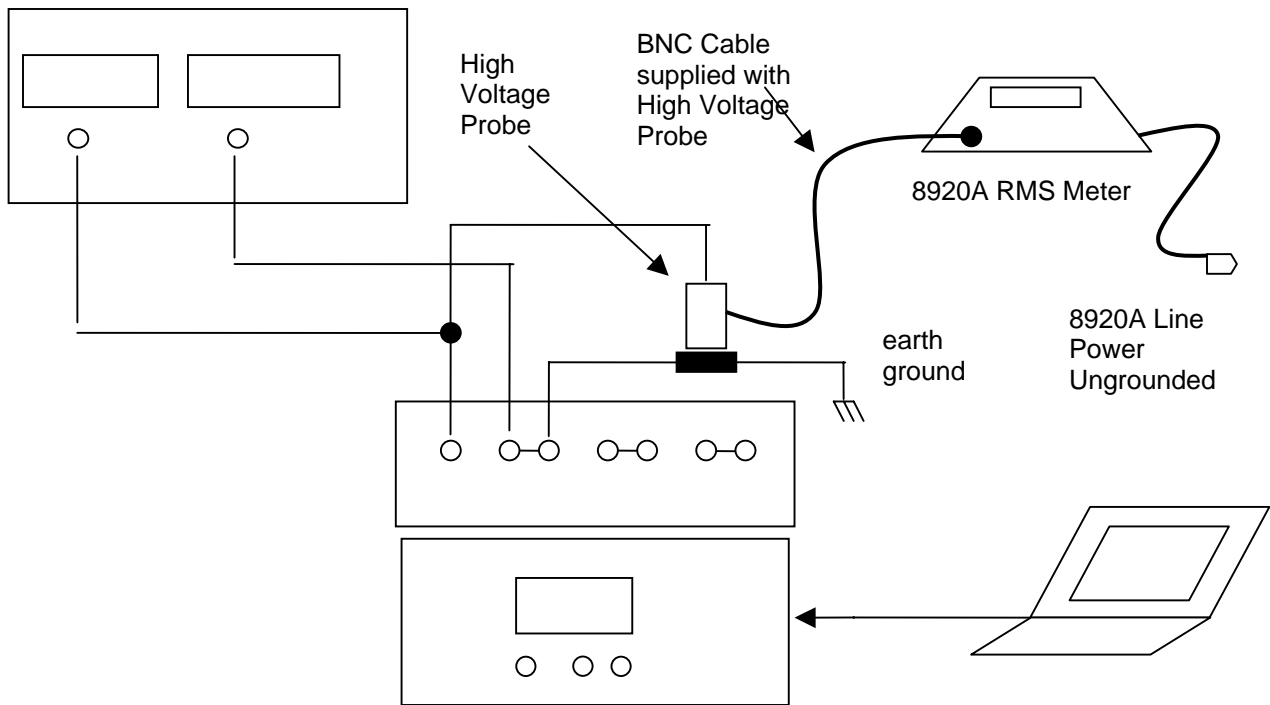
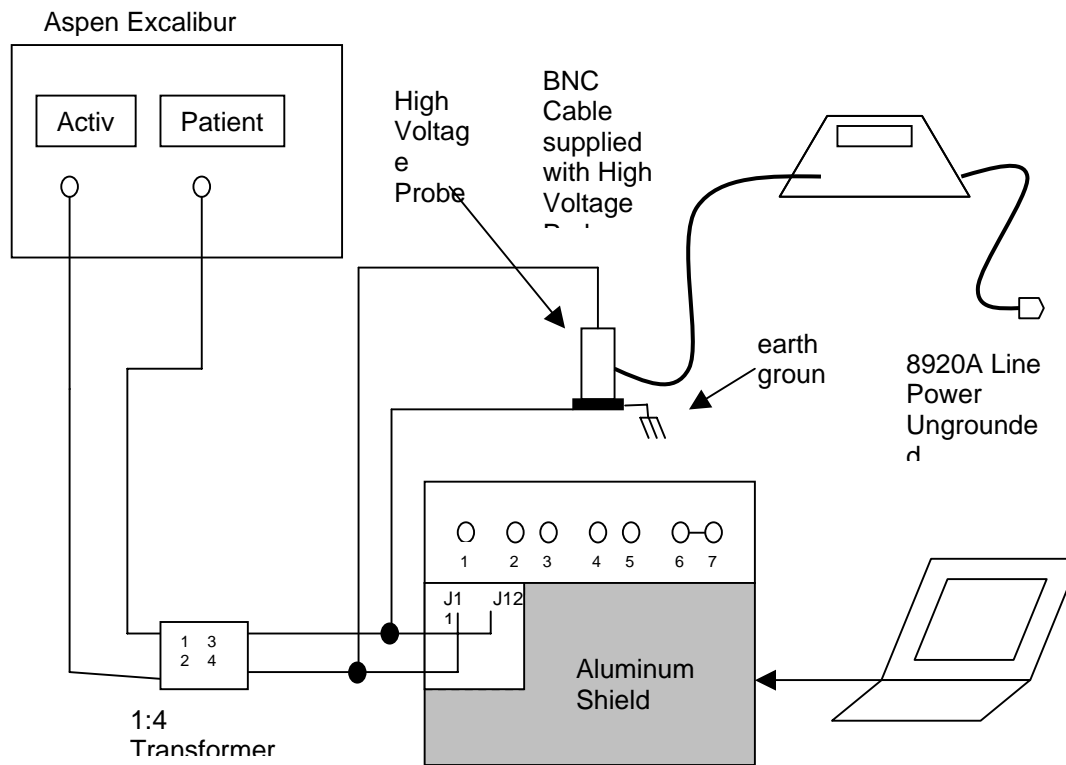

Figure 2.3A: Range 0 to Range 7 Low end and Range 0 to Range 4 High end Adjustment Equipment Setup

Date 11/27/06		Title Calibration Procedure for 402A Performance Check					
Rev.	ECN No.	Released for	Doc. Ctrl.	Sheet	No.	CAL-402A	Size
1	9190	Production	DLN	Page 8 of 14			CAL

Table 2-2: Approximate Aspen Excalibur Settings for Calibration

CALSTEP	Approximate Aspen Output (WATTS)	Desired ADC Counts	402A Attenuation Range
8	1	500 +/- 50	0 low
9	1	250 +/- 50	1 low
10	8 – 10	250 +/- 50	2 low
11	3	250 +/- 50	3 low
12	6	250 +/- 50	4 low
13	26	250 +/- 50	5 low
14	105 – 110	250 +/- 50	6 low
15	300	150 +/- 50	7 low
16	15	1000 +/- 100	0 high
17	53	1000 +/- 100	1 high
18	184	1000 +/- 100	2 high
19	98	1000 +/- 100	3 high
20	219	1000 +/- 100	4 high



1. Remove top cover of UUT.
2. Remove HV leads from load board to Main Board at J11 and J12.
3. Connect Calibration

Gently set cover over instrument during calibration, leaving the High Voltage Terminals exposed.

Figure 2.3B: Range 5 to Range 7 High end Adjustment Equipment Setup

Date 11/27/06		Title Calibration Procedure for 402A Performance Check					
Rev. 1	ECN No. 9190	Released for Production	Doc. Ctrl. <i>DLW</i>	Sheet Page 9 of 14	No.	CAL-402A	Size CAL

## Range 5 to Range 7 High end adjustment procedure



**WARNING:** This test will consist of taking measurements using the Aspen Excalibur ESU with the output connected directly to the 402A Main Board input amplifier circuit. The voltages present at the output of the 1:4 transformer are in excess of 1000 Volts RMS and can cause severe burns and electrical shock. Always verify that the Aspen Excalibur output leads are connected to the 1:4 transformer input terminals AND verify that the 1:4 transformer output terminals are connected to the 402A Main Board terminals J11 and J12 BEFORE increasing the power out of the Aspen from 0 Watts.

1. Set up equipment as shown in Figure 2.3B.
2. Adjust Aspen Excalibur Pure Cut (1 Watt out) output power as necessary to obtain 1300 +/- 200 counts. After reading stabilizes press <enter> then type in the RMS Volts indicated on the 8920A. Press <enter>. The three ranges to check with the Aspen Excalibur settings are provided in the following table can be followed after the technician is familiar with the procedure.

### Note:

An ADC count of 1300 +/- 200 is the minimum obtainable in this calibration step.

3. Adjust the Aspen Excalibur Pure Cut (14 Watts out) output power as necessary to obtain 1000 +/- 200 counts. After reading stabilizes (approximately 3 seconds), press <enter> then type in the RMS Volts indicated on the 8920A. Press <enter>.
4. Adjust the Aspen Excalibur Pure Cut (40 Watts out) output power as necessary to obtain 500 +/- 50 counts. After reading stabilizes (approximately 3 seconds), type in RMS Volts indicated on 8920A and press <enter>.

### Note:

An ADC count of 500 +/- 50 is the maximum obtainable in this calibration step.

Table 2-3: Aspen Excalibur Pure Cut Calibration

CAL STEP	Approximate Aspen Output (WATTS)	Desired ADC Counts	402A Attenuation Range
21	1	1300 +/- 100	5 high
22	14	1000 +/- 100	6 high
23	40	500 +/- 50	7 high

5. The Calibration Program will now prompt the technician to save the data. If the Calibration procedure has been completed, enter <y> or <Y> at the prompt. The calibration coefficients will be written to EEROM. Press any other key to exit the Calibration Program without saving the data.
6. The Calibration Routine is now complete.
7. Set Aspen Pure Cut output power to 0 Watts and disconnect the ESU from the UUT
8. Disconnect Upper Range Calibration leads and reconnect High Voltage Jumpers from the 402A Load Assembly to the 402A Main Board. Verify the connection is solid and that the spade lugs on the 402A Main Board are not bent.

Date		12/11/06		Title		Calibration Procedure for 402A Performance Check			
Rev.	ECN No.	Released for	Doc. Ctrl.	Sheet	No.	CAL-402A			Size
1	9190	Production	<i>DLN</i>	Page 10 of 14					CAL

### Verification and Scope Out Check

1. Set up equipment as shown in Figure 2.3A.
2. Set the Aspen Pure Cut power output levels to the values listed in the table below. For each setting, press <enter> when the UUT Display stabilizes and observe the RMS Volts displayed on the 8920A. The verification program will calculate the tolerances of the RMS Volts displayed on the 402A and display it on the serial port monitor along with the specified tolerances. The RMS Volts recorded from 8920A must fall within the voltage limits indicated on the serial port monitor.

Table 2-4: Aspen Pure Cut power output levels

CAL STEP	Approximate Aspen Output Pure Cut (Watts)	Attenuation Range Checked
24	1	0
25	1	1
26	9	2
27	3	3
28	6	4
29	26	5
30	100	6
31	300	7

3. The Calibration Program will prompt the technician to save the data. If the verification check is complete, enter <n> or <N> at the prompt.

**NOTE**

Entering <y> or <Y> will not overwrite the calibration data already stored in EEPROM.

4. Connect the Scope Out BNC connector on the UUT to the Oscilloscope Channel A input using the 50 ohm feed through termination. Set the ESU for a PURE CUT signal of 1 Watt and observe waveform. Verify the waveform closely resembles the waveform in Figure XX

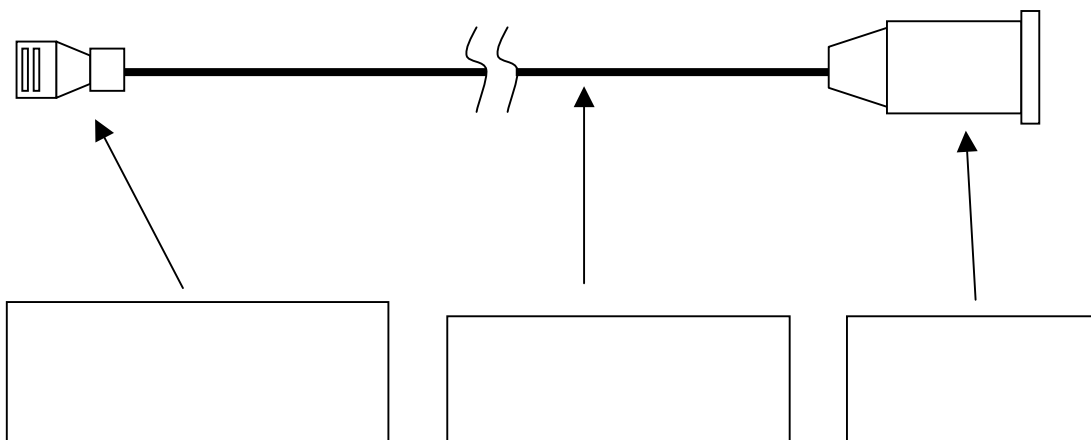

Date 12/11/06		Title Calibration Procedure for 402A Performance Check					
Rev.	ECN No.	Released for	Doc. Ctrl.	Sheet	No.	CAL-402A	Size
1	9190	Production	<i>DLV</i>	Page 11 of 14			CAL

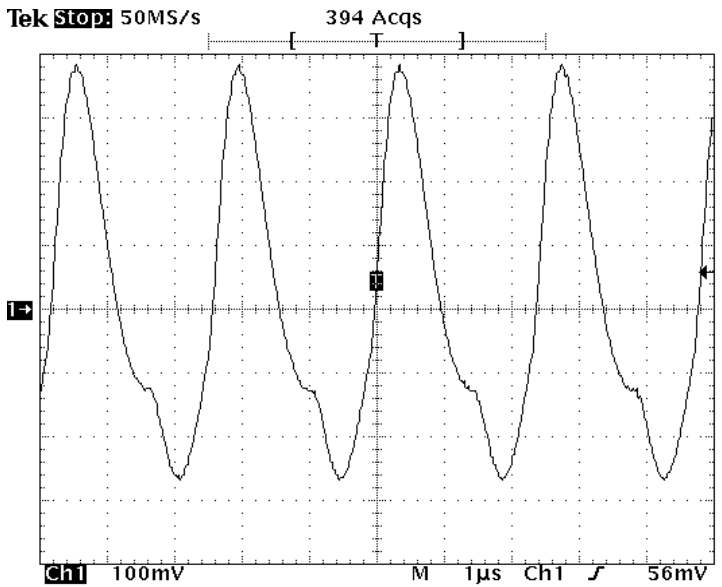

Figure 1.4: Aspen Excalibur Pure Cut Waveform

7 Jan 1999  
09:53:34

5. Set output of Aspen to 0 Watts and disconnects from UUT.
6. Secure the instrument top with the nylon screws provided. (8 each, DNI P/N 4710-0013).

Table: 2-5; Test Matrix using the Aspen Excalibur ESU as source.

402A Range	Low End Load (ohms)	High End Load (ohms)	Low End Target RMS Volts	Low End Target ADC Counts	High End Target RMS Volts	High End Target ADC Counts
	0	50	50	8.20	500	16.99
1	50	50	8.25	259	33.4	1014
2	50	50	12.59	202	66.7	1010
3	200	200	26.4	211	132.9	1013
4	500	500	61.9	200	336	1008
5	500	unloaded	124.8	202	865	1321
6	500	unloaded	257	205	1323	1012
7	750	unloaded	365	151	1515	585

### Calibration Jumpers

Calibration Jumpers to connect output of 1:4 transformer to HV Taps (J5 and J8) on the 402A Main Board.

Date	12/11/06	Title					Calibration Procedure for 402A Performance Check
Rev.	ECN No.	Released for	Doc. Ctrl.	Sheet	No.	CAL-402A	Size
1	9190	Production	<i>DLV</i>	Page 112 of 14			CAL

# Diagnostic Firmware

## Diagnostic Firmware Commands

The diagnostic firmware was written with the intention of providing data to the technician useful for troubleshooting. It also provides a means to quickly assess the state of a 402A requiring service.

Establish serial communication as outlined in Chapter 1.

- At the <?> prompt type **DIAG** <Enter>.
- Press the <?> and then <Enter> to display the following commands;

Menu of Diagnostic Mode Commands	
<b>A</b>	ADC Channel
<b>B</b>	Buzzer
<b>C</b>	Cal Constants
<b>D</b>	Display Test
<b>E</b>	EEPROM Test
<b>I</b>	Identification
<b>K</b>	Key Test
<b>L</b>	Load
<b>M</b>	RAM Test (pass or fail)
<b>O</b>	RMS Offset (in mV)
<b>P</b>	EPROM Check
<b>R</b>	Range
<b>S</b>	Fan Speed
<b>T</b>	Temperature (returns “hot” or “cold”)
<b>V</b>	Battery Voltage
<b>Y</b>	Battery State
<b>Z</b>	Collect Data (Engineering use only)
<b>?</b>	Menu
<b>Q</b>	Quit

Date 12/11/06

Title Calibration Procedure for 402A Performance Check

Rev.	ECN No.	Released for	Doc. Ctrl.	Sheet	No.	Size
1	9190	Production	<i>DLV</i>	Page 13 of 14	CAL-402A	CAL

**Load (L)** sets the load of the instrument. There are 15 loads, 50 to 750 ohms, in 50 ohm increments. To set the load, enter <Ln>, where *n* is the integer argument corresponding to the load. The arguments and the corresponding load values are as follows:

RANGE	LOAD
1	50
2	100
3	150
4	200
5	250
6	300
7	350
8	400
9	450
10	500
11	550
12	600
13	650
14	700
15	750

**ADC Channel (An)** Reads a single sample on the specified ADC Channel. There are five channels, 0 to 4. To read the ADC Channel enter <An>, where *n* is the integer argument corresponding to the ADC Channel. The arguments and the corresponding ADC Channels are as follows:

CHANNELS	DESCRIPTION
0	RMS to DC Converter Out
1	Positive Peak Detector
2	Negative Peak Detector
3	Temperature of Load Thermistors
4	Battery Voltage

Calibration constants can be displayed with the (C) command. This data is for display purposes ONLY. The constants cannot be modified via the diagnostic software.

Date 12/11/06		Title Calibration Procedure for 402A Performance Check					
Rev.	ECN No.	Released for	Doc. Ctrl.	Sheet	No.	CAL-402A	Size
1	9190	Production	<i>DLV</i>	Page 14 of 14			CAL