

Service Guide

Agilent Technologies

ESG Family Signal Generators

Serial Number Prefixes:

ESG-A Series:	≤ US4005/GB4005
ESG-D Series:	≤ US4005/GB4005
ESG-AP Series:	US3926/GB3926
ESG-DP Series:	US3926/GB3926

Depending on your firmware revision, front panel operation may vary from descriptions in this guide



Part No. E4400-90335

Printed in USA

June 2000

Supersedes May 2000

© Copyright 1999, 2000 Agilent Technologies

COPYRIGHT AND DISCLAIMER NOTICE

Copyright – Agilent Technologies, Inc. Reproduced with the permission of Agilent Technologies Inc. Agilent Technologies, Inc. makes no warranty of any kind with regard to this material including, but not limited to, the implied warranties of merchantability and fitness for a particular purpose. Agilent Technologies, Inc. is not liable for errors contained herein or for incidental or consequential damages in connection with the furnishing, performance, or use of this material or data.

Contents

1. Initial Troubleshooting and RF

Block Diagrams

Before You Begin Troubleshooting	1-2
Using this Service Guide to Troubleshoot	1-2
Signal Generator Options	1-3
Contacting Agilent Technologies	1-7
Equipment Required for Troubleshooting	1-10
Initial Troubleshooting	1-11
Additional Information for Troubleshooting the ESG-AP and ESG-DP Series	1-22
ESG-A Series RF Block Diagram (Standard & Option 1E6)	1-23
ESG-D Series RF Block Diagram	1-25
ESG-D Series RF Block Diagram (Options UN3 & UN4)	1-27
ESG-D Series RF Block Diagram (Option UN7)	1-29
ESG-D Series RF Block Diagram (Options UN8 & UN9)	1-31
ESG-D Series RF Block Diagram (Option UND)	1-33
ESG-D Series RF Block Diagram (Option UN7, UN8/UN9, & 300)	1-35
ESG-AP Series RF Block Diagram (Standard & Option 1E6)	1-37
ESG-DP Series RF Block Diagram	1-39
ESG-DP Series RF Block Diagram (Option UN7)	1-41
ESG-DP Series RF Block Diagram (Options UN8 & UN9)	1-43
ESG-DP Series RF Block Diagram (Option UND)	1-45
Blue Repair Tags	1-47

2. Assembly-Level Troubleshooting with

Block Diagrams

Before You Begin Troubleshooting	2-2
Using this Chapter with Service Software	2-2
A5 Dual Arbitrary Waveform Generator Block Diagram (Option UND)	2-5
A6 Bit Error Rate Test Block Diagram (Option UN7)	2-7
A7 Baseband Generator Block Diagram (Options UN3 & UN4)	2-9
A7 DBMIC Baseband Generator Block Diagram (Options UN8 & UN9)	2-11
A8 Data Generator Block Diagram (Options UN3 & UN4)	2-13
A8 Data Generator - Rev. A & B Block Diagram (Options UN8 & UN9)	2-15
A8 Flex Data Generator - Rev. C & D Block Diagram (Options UN8 & UN9)	2-17
A9 Output ABUS Nodes (ESG-A Series)	2-19
A9 Output Block Diagram (ESG-A Series)	2-21
A9 Output ABUS Nodes (ESG-D Series)	2-23
A9 Output ABUS Nodes (ESG-AP, & ESG-DP Series)	2-25
A9 Output Block Diagram (ESG-D, ESG-AP, & ESG-DP Series)	2-27

Contents

A11 Reference ABUS Nodes (ESG-A & ESG-D Series)	2-29
A11 Reference Block Diagram (ESG-A & ESG-D Series)	2-31
A11 Reference ABUS Nodes (ESG-AP & ESG-DP Series)	2-33
A11 Reference Block Diagram (ESG-AP & ESG-DP Series)	2-35
A12 Synthesizer/Doubler ABUS Nodes (ESG-A & ESG-D Series)	2-37
A12 Synthesizer/Doubler Block Diagram (ESG-A & ESG-D Series)	2-39
A14 CPU/Motherboard ABUS Nodes	2-41
A14 CPU/Motherboard Block Diagram (1 of 2)	2-43
A14 CPU/Motherboard Block Diagram (2 of 2)	2-45
A20 Downconvertor Block Diagram (Option 300)	2-47
A21 Demodulator Block Diagram (Option 300)	2-49
A22 YIG Driver ABUS Nodes (ESG-AP & ESG-DP Series)	2-51
A22 YIG Driver Block Diagram (ESG-AP & ESG-DP Series)	2-53
A23 Sampler ABUS Nodes (ESG-AP & ESG-DP Series)	2-55
A23 Sampler Block Diagram (ESG-AP & ESG-DP Series)	2-57
A24 Frac-N/Divider ABUS Nodes (ESG-AP & ESG-DP Series)	2-59
A24 Frac-N/Divider Block Diagram (ESG-AP & ESG-DP Series)	2-61
AT1 Electronic Attenuator/RPP Block Diagram	2-63
AT1 Mechanical Attenuator and A19 RPP Block Diagram (Option UNB)	2-65
ESG-A Series Power Supply and Ground Interconnects Block Diagram	2-67
ESG-D Series Power Supply and Ground Interconnects Block Diagram (1 of 2)	2-69
ESG-D Series Power Supply and Ground Interconnects Block Diagram (2 of 2)	2-71
ESG-A Series Modulation and Signal Interconnects Block Diagram	2-73
ESG-D Series Modulation and Signal Interconnects Block Diagram (1 of 2)	2-75
ESG-D Series Modulation and Signal Interconnects Block Diagram (2 of 2)	2-77

3. Replaceable Parts

(ESG-A and ESG-D Series)

Ordering Information	3-2
Save Money with Rebuilt-Exchange Assemblies	3-3
Abbreviations Used in Part Descriptions	3-5
Major Assemblies	3-7
Cables	3-15
Hardware and Other Instrument Parts	3-45
Miscellaneous	3-72

4. Replaceable Parts

(ESG-AP and ESG-DP Series)

Ordering Information	4-2
Save Money with Rebuilt-Exchange Assemblies	4-3
Abbreviations Used in Part Descriptions	4-5
Major Assemblies	4-7
Cables	4-13
Hardware and Other Instrument Parts	4-39
Miscellaneous	4-66

Contents

5. Assembly Replacement	
Before You Replace an Assembly	5-2
After Replacing an Assembly	5-2
Assemblies That You Can Replace	5-3
A1 Front Panel Board	5-4
A2 Display	5-6
A2DS1 Fluorescent Lamp	5-9
A3 Inverter	5-10
A4 Power Supply	5-12
A4 Power Supply (with Option 1EM)	5-15
A14 CPU/Motherboard	5-18
A14BT1 Battery	5-24
A14Q501 Transistor	5-26
A15 Daughterboard	5-28
A16 Line Module	5-32
A17 and A18 Rear Panel Interface Boards	5-34
A19 Reverse Power Protection (RPP)	5-36
A20 Downconverter	5-39
A22 YIG Driver	5-40
A25 Pulse Modulator	5-41
A25 Pulse Modulator (with Option UNB)	5-43
AT1 Electronic Attenuator/RPP	5-46
AT1 Mechanical Attenuator	5-48
B1 Small Fan	5-52
B2 Large Fan	5-54
Daughterboard Card Cage Boards	5-56
Digital Card Cage Boards	5-58
Front Panel	5-60
Instrument Cover	5-64
Rear Panel	5-66
Rear Panel (with Option 1EM)	5-70
Semi-Rigid Cables	5-73
6. Post-Repair Procedures	
Performance Tests	6-2
Adjustments	6-7
7. Safety and Regulatory	
Safety Notes	7-2
General Safety Considerations	7-3
Lithium Battery Disposal	7-4
Warranty	7-5
Assistance	7-6
Notice	7-7
Certification	7-8

Contents

1 Initial Troubleshooting and RF Block Diagrams

This chapter will help you begin troubleshooting your signal generator. The procedures in this chapter primarily check your instrument for failures that affect the power supplies or CPU function. An RF block diagram of your signal generator is at the end of this chapter.

Before You Begin Troubleshooting

Be sure to review the warning and caution statements described in Chapter 7 prior to troubleshooting your signal generator.

Using this Service Guide to Troubleshoot

Several chapters in this service guide work together to help you troubleshoot and repair your signal generator.

- **Chapter 1, “Initial Troubleshooting and RF Block Diagrams,”** helps you get started with some basic checks and instructions.
- **Chapter 2, “Assembly-Level Troubleshooting with Block Diagrams,”** helps you identify and verify the failed assembly.
- **Chapter 3, “Replaceable Parts (ESG-A & ESG-D),”** helps you locate the failed assembly or cable in the signal generator and also provides you with part numbers and ordering information.
- **Chapter 4, “Replaceable Parts (ESG-AP & ESG-DP),”** helps you locate the failed assembly or cable in the signal generator and also provides you with part numbers and ordering information.
- **Chapter 5, “Assembly Replacement,”** gives you step-by-step instructions on how to remove and replace an assembly.
- **Chapter 6, “Post-Repair Procedures,”** lists the performance tests and adjustments that must be performed after an assembly has been repaired or replaced.

Signal Generator Options

This section lists the hardware, software, and documentation options you can order with a new signal generator. Some of the options can be retrofitted into your existing signal generator. Order a retrofit by requesting either the post-sales option number or the part number.

Hardware and Software Options Available for New Instruments						
Desired Option	ESG-A	ESG-D	ESG-AP	ESG-DP	Required Options	Incompatible Options
100		X		X	UND	
101		X		X	UND	
1CM	X	X	X	X		
1CN	X	X	X	X		
1CP	X	X	X	X		
1EM	X	X	X	X		
1E5	X	X	Standard	Standard		
1E6	X		X			
300		X		X	UN7, UN8	
UN5		X		X	UND	
UN7		X		X	UN3, UN4, or UN8	
UN8		X		X		
UN9		X		X	UN8	
UNA		X		X	UN8	UNB
UNB		X		X		UNA
UND		X		X		

Adding Hardware and Software Options to Existing Instruments				
Desired Option	Existing Option	Required Options	Post-Sales Option	Part Number
100		UND	150	
101		UND	151	
300		UN7, UN8		
UN5		UND	005	
UN7		UN3, UN4, or UN8	007	E4400-60143
UN8			008	E4400-60170
UN8	UN3 or UN4			E4400-60160
UN8 and UN9			009	E4400-60185
UN8 and UN9	UN3 or UN4			E4400-60184
UND			004	E4400-60166
UND	UN3 or UN4			E4400-60181

Option	Description
100	<p>Option 100 has two implementations:</p> <p>Multichannel W-CDMA (Revision 1.0-1.2) Personality - This first implementation of Option 100 simulates multichannel forward and reverse link signals according to the developing W-CDMA international standards. Spreading and frame structure of these signals are implemented according to March 1999 ARIB 1.0 - 1.2 specification.</p> <p>Multichannel W-CDMA (3GPP 3.1 12-99) Personality - This second implementation of Option 100 simulates multichannel downlink and uplink signals according to the developing W-CDMA international standards. This option implements a chip rate of 3.84 Mcps, and is based on the December 1999 3GPP 3.1 specification.</p>
101	<p>Multichannel CDMA2000 Personality - This option simulates multichannel forward and reverse link signals according to the developing CDMA2000 standard revision 8.</p>
1CM	<p>Rack Mount Flanges without Handles - This option adds two flanges and the necessary hardware to rack mount the signal generator in a System II or System II Plus cabinet.</p>
1CN	<p>Front Handles - This option adds two front handles with the necessary hardware to attach the handles to the front of the signal generator.</p>
1CP	<p>Rack Mount Flanges with Handles - This option adds two front handles, two flanges, and the necessary hardware to rack mount the signal generator in an System II or System II Plus cabinet.</p>
1E5	<p>High Stability Timebase - This option replaces the standard timebase reference assembly with a high-stability timebase reference assembly that has improved specifications over the standard assembly, including warranted specifications for aging rate. This feature is standard on ESG-AP and ESG-DP Series Signal Generators.</p>
1E6	<p>High Performance Pulse Input - This option provides high performance pulse capabilities with rise and fall times < 10 ns and on/off ratios > 70 dB.</p>
1EM	<p>Move All Front Panel Connectors to Rear Panel - This option moves all of the front panel connectors to the rear panel. If you order Option 1EM in combination with any option that adds front panel connectors, Option 1EM will cause all of the front panel connectors to be moved to the rear panel and, in addition, some of the connectors will be changed from BNC to SMB connectors.</p>
201	<p>Multichannel Real-Time cdma2000 Personality - This option can be used to provide fully coded, multichannel forward link signals supporting both the IS-95 and IS-2000 CDMA standards.</p> <p>Support for IS-2000 is accomplished through the use of two ESG signal generators. Because IS-2000 provides backward compatibility with IS-95 in RC1 and RC2 configurations, the Option 201 personality also supports the IS-95 standard.</p>

- 300 Base Station BERT Extension for Option UN7 - This option adds bit error rate testing for GSM base stations to the ESG/VSA combination.
- ES1 This option indicates that a more recent version of firmware is resident in the signal generator than was originally shipped. The operating features in the new firmware may be different than those documented in your original manual set.
- UN3 I/Q Baseband Generator with 1 Mbit Pattern RAM (Obsolete) - *This option is no longer available.* Option UN3 provided an I/Q baseband generator with DECT, GSM, NADC, PDC, PHS, and TETRA digital modulation formats. Pre-modulation filtering selections and PRBS capability with 8 Mbits of pattern RAM were also provided. Option UN3 is replaced by Option UN8.
- UN4 I/Q Baseband Generator with 8 Mbit Pattern RAM (Obsolete) - *This option is no longer available.* Option UN4 provided an I/Q baseband generator with DECT, GSM, NADC, PDC, PHS, and TETRA digital modulation formats. Pre-modulation filtering selections and PRBS capability with 8 Mbits of pattern RAM were also provided. Option UN4 is replaced by Option UN8 with Option UN9 added for additional RAM.
- UN5 Multi-Channel CDMA - This option provides multi-channel CDMA capability, which provides flexible, coded-channel setups for CDMA base stations or mobiles, components, or sub-system test.
- UN7 Bit Error Rate Test - This option adds a bit error rate test function that evaluates PN9 or PN15 bit streams for errors. Configuration of data, clock, and clock gate inputs allow testing of demodulated TDMA or CDMA formats. A baseband generator must be part of the instrument configuration.
- UN8 Real-time I/Q Baseband Generator - This option provides a custom modulation generator with 1 Mbit of pattern RAM. The custom modulation generator provides generic symbol building, variable symbol rates, and variable filter capabilities in addition to TDMA protocols.
- UN9 +7 Mbits RAM - This option adds an additional 7 Mbits of pattern RAM to Option UN8 for very long data pattern generation. You must purchase Option UN8 in conjunction with Option UN9.
- UNA Alternate Timeslot Power Level Control - This option provides alternate timeslot power level control for adjacent timeslots in TDMA applications.
- UNB High Power with Mechanical Attenuator - This option provides a mechanical attenuator that provides 4 to 6 dB more output power than the standard electronic attenuator.

Signal Generator Options**UND**

Internal Dual Arbitrary Waveform Generator - This option provides an internal dual arbitrary waveform generator that contains an on-board digital signal processor capable of playing back downloaded waveforms to generate complex, digitally modulated signals. A 1 Megasample per channel memory accepts I/Q files from different waveform generation programs, such as Omnisys and Matlab. 14 bit DACs optimize dynamic range and reduce noise.

Contacting Agilent Technologies

This section prepares you for contacting Agilent Technologies should you have a problem with your signal generator.

Check the Basics before Contacting Agilent Technologies

Often problems may be solved by repeating what was being done when the problem occurred. A few minutes spent in performing these simple checks may eliminate time spent waiting for instrument repair.

- Check that the signal generator is plugged into the proper ac power source.
- Check that the line socket has power.
- Check that the signal generator is turned on.
- Check that the other equipment, cables, and connectors are connected properly and operating correctly.
- Check the equipment settings in the procedure that was being used when the problem occurred.
- Check that the test being performed and the expected results are within the specifications and capabilities of the signal generator. (Refer to the calibration guide.)
- Check the signal generator display for error messages. (Refer to the Error Messages guide.)
- Check operation by performing the verification procedures in the calibration guide. Record all results in the performance test record.

Review the Warranty

If there is still a problem, read the warranty printed in Chapter 7, "Safety and Regulatory." If your signal generator is covered by a separate maintenance agreement, be familiar with its terms.

Agilent Technologies offers several maintenance plans to service your signal generator after warranty expiration. Call your Agilent Technologies sales and service office for full details.

Calling Agilent Technologies Sales and Service Offices

Sales and service offices are located around the world to provide complete support for your signal generator. To obtain servicing information, contact the nearest Agilent Technologies Sales and Service office listed in Table 1-1. For information on ordering parts refer to Chapter 3 or Chapter 4.

In any correspondence or telephone conversation, refer to the signal generator by its model number and full serial number. With this information, the Agilent Technologies representative can quickly determine whether your unit is still within its warranty period.

Contacting Agilent Technologies

Table 1-1 Agilent Technologies Sales and Service Offices

UNITED STATES		
Instrument Support Center Agilent Technologies (800) 403-0801		
EUROPEAN FIELD OPERATIONS		
Headquarters Agilent Technologies S.A. 150, Route du Nant-d'Avril 1217 Meyrin 2/ Geneva Switzerland (41 22) 780.8111	France Agilent Technologies France 1 Avenue Du Canada Zone D'Activite De Courtaboeuf F-91947 Les Ulis Cedex France (33 1) 69 82 60 60	Germany Agilent Technologies GmbH Agilent Technologies Strasse 61352 Bad Homburg v.d.H Germany (49 6172) 16-0
Great Britain Agilent Technologies Eskdale Road, Winnersh Triangle Wokingham, Berkshire RG41 5DZ England (44 118) 9696622		
INTERCON FIELD OPERATIONS		
Headquarters Agilent Technologies 3495 Deer Creek Rd. Palo Alto, CA 94304-1316 USA (415) 857-5027	Australia Agilent Technologies Australia Ltd. 31-41 Joseph Street Blackburn, Victoria 3130 (61 3) 895-2895	Canada Agilent Technologies (Canada) Ltd. 17500 South Service Road Trans-Canada Highway Kirkland, Quebec H9J 2X8 Canada (514) 697-4232
Japan Agilent Technologies Japan, Ltd. 9-1 Takakura-Cho, Hachioji Tokyo 192, Japan (81 426) 60-2111	Singapore Agilent Technologies Singapore (Pte.) Ltd. 150 Beach Road #29-00 Gateway West Singapore 0718 (65) 291-9088	Taiwan Agilent Technologies Taiwan 8th Floor, H-P Building 337 Fu Hsing North Road Taipei, Taiwan (886 2) 712-0404
China China Agilent Technologies 38 Bei San Huan X1 Road Shuang Yu Shu Hai Dian District Beijing, China (86 1) 256-6888		

Returning Your Signal Generator for Service

Use the information in this section if you need to return the signal generator to Agilent Technologies.

Packaging the Signal Generator

Use the following steps to package the signal generator for shipment to Agilent Technologies for service:

1. Fill out a blue repair tag (available at the end of this chapter) and attach it to the instrument. Be as specific as possible about the nature of the problem. Send a copy of any or all of the following information:
 - Any error messages that appeared on the signal generator display.
 - A completed performance test record from the calibration guide for your instrument.
 - Any other specific data on the performance of the signal generator.
2. Use the original packaging materials or a strong shipping container that is made of double-walled, corrugated cardboard with 159 kg (350 lb) bursting strength. The carton must be both large enough and strong enough to accommodate the signal generator and allow at least 3 to 4 inches on all sides of the signal generator for packing material.

CAUTION Signal generator damage can result from using packaging materials other than those specified. Never use styrene pellets, in any shape, as packaging materials. They do not adequately cushion the instrument or prevent it from shifting in the carton. Styrene pellets cause equipment damage by generating static electricity and by lodging in the signal generator fan.

3. Surround the instrument with at least 3 to 4 inches of packing material, or enough to prevent the instrument from moving in the carton. If packing foam is not available, the best alternative is SD-240 Air Cap™ from Sealed Air Corporation (Hayward, CA 94545). Air Cap looks like a plastic sheet covered with 1-1/4 inch air-filled bubbles. Use the pink Air Cap to reduce static electricity. Wrap the instrument several times in the material to both protect the instrument and prevent it from moving in the carton.
4. Seal the shipping container securely with strong, nylon adhesive tape.
5. Mark the shipping container “FRAGILE, HANDLE WITH CARE” to ensure careful handling.
6. Retain copies of all shipping papers.

Equipment Required for Troubleshooting

Table 1-2 lists the equipment required to troubleshoot your signal generator. You may use the recommended model or an equivalent that meets the critical specifications.

Table 1-2 Recommended Test Equipment

Equipment	Critical Specifications for Equipment Substitution	Recommended Model Number
Digital Multimeter	Input Resistance: $\leq 10\text{ M}\Omega$ Accuracy: 10 mV on 100 V range	HP/Agilent 3458A

Initial Troubleshooting

Perform the following troubleshooting steps in the order they are presented. If you are unable to identify the failed assembly, go to Chapter 2, “Assembly-Level Troubleshooting with Block Diagrams,” for further instruction.

NOTE *Do not attempt to replace any fuses within the power supply to correct a problem with your signal generator. If you determine that the power supply is the failed assembly, replace the power supply.*

Step 1: Observe the Front and Rear Panel LEDs

Observing the LEDs on the front and rear panel of the signal generator will determine if there is a catastrophic failure in the power supply assembly.

1. Ensure the signal generator is plugged in (*do not* switch the power on) and verify that the yellow LED on both the front and rear panels is lit. Refer to Figure 1-1 for LED locations. A lit yellow LED (+15 V_STBY) indicates that line voltage is present.
2. Power on the signal generator and verify that the green LED on both the front and rear panels is lit. A lit green LED indicates the power supply has received an “ON” command. The ON/OFF switch toggles a flip-flop latch which biases the proper transistors in the LED control circuit. This circuit is powered by VBAT, the battery-backed SRAM supply, so that the on-off state is “remembered” even when the instrument is unplugged.

Figure 1-1 LED Locations on the Front and Rear Panels

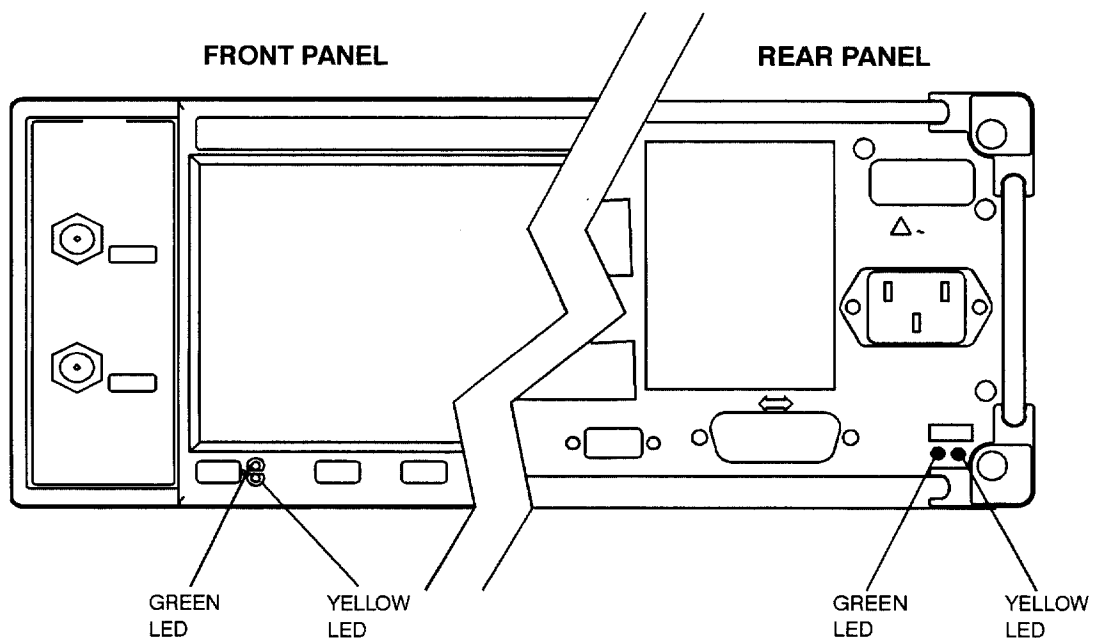

sk7116a

Step 2: Power On the Signal Generator and Check for Error Messages

This procedure verifies that the signal generator powers up and that the internal instrument check identifies no errors. The internal check evaluates the correctness of operation and returns an error message if a problem is detected.

1. Switch on the signal generator. Let the signal generator warm up for at least five minutes.

NOTE For ESG-AP, ESG-DP, and Option 1E5 signal generators, **ERROR 514, Reference Oven Cold** will occur whenever the signal generator is powered up within five minutes of being connected to AC line power. The **OVEN COLD** annunciator and the **ERR** annunciator will both turn on. The **OVEN COLD** annunciator will automatically clear after approximately five minutes. The error queue *cannot* be cleared, however, until the **OVEN COLD** annunciator has turned off.

2. Cycle the power to the signal generator and verify that the green LED on both the front and rear panels is lit. Refer to Figure 1-1.
3. When the display is lit, check to see if the **ERR** annunciator is turned on.
4. If the **ERR** annunciator is turned on, review the error messages in the queue by pressing **Utility > Error Info > View Next Error Message**. The first error message in the queue will be shown in the text area of the display. Refer to the *Error Messages* guide for descriptions of error messages.

If there is more than one error message (each message will be designated as 1 of *n*), continue pressing the **View Next Error Message** softkey until you have seen and recorded all of the messages.

5. If you were able to resolve all of the error messages, press **Utility > Error Info > Clear Error Queue(s)** to delete the list of error messages.

Step 3: Functional Check the Front Panel Keys and Display

1. Press various front panel hardkeys and softkeys to verify they function as expected.
2. Use the contrast keys to verify that the display can be lightened and darkened. Refer to Figure 1-2.

Figure 1-2 Contrast Keys

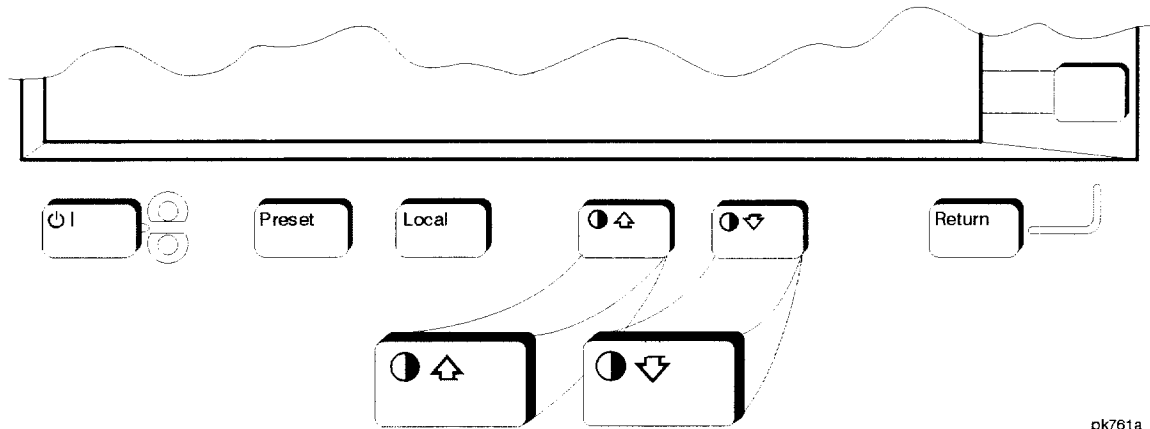

Step 4: Visually Check the Individual Voltage Supplies

1. Unplug the signal generator and remove the instrument cover. Refer to Chapter 5, "Assembly Replacement," for removal instructions.
2. Expose the motherboard by removing the top cover. It is secured by 11 screws.
3. Plug in the signal generator and allow it to warm up for at least five minutes.
4. If possible, clear the error queue(s) of messages. Press **Utility > Error Info > Clear Error Queue(s)**.
5. On the motherboard, locate the 10 LEDs that correspond to the individual voltage supplies (see Figure 1-3). Verify that all the LEDs are lit. If one or more LEDs are off, proceed to "Step 6: Isolate the Failed Assembly".

Figure 1-3 LED Locations on the Motherboard

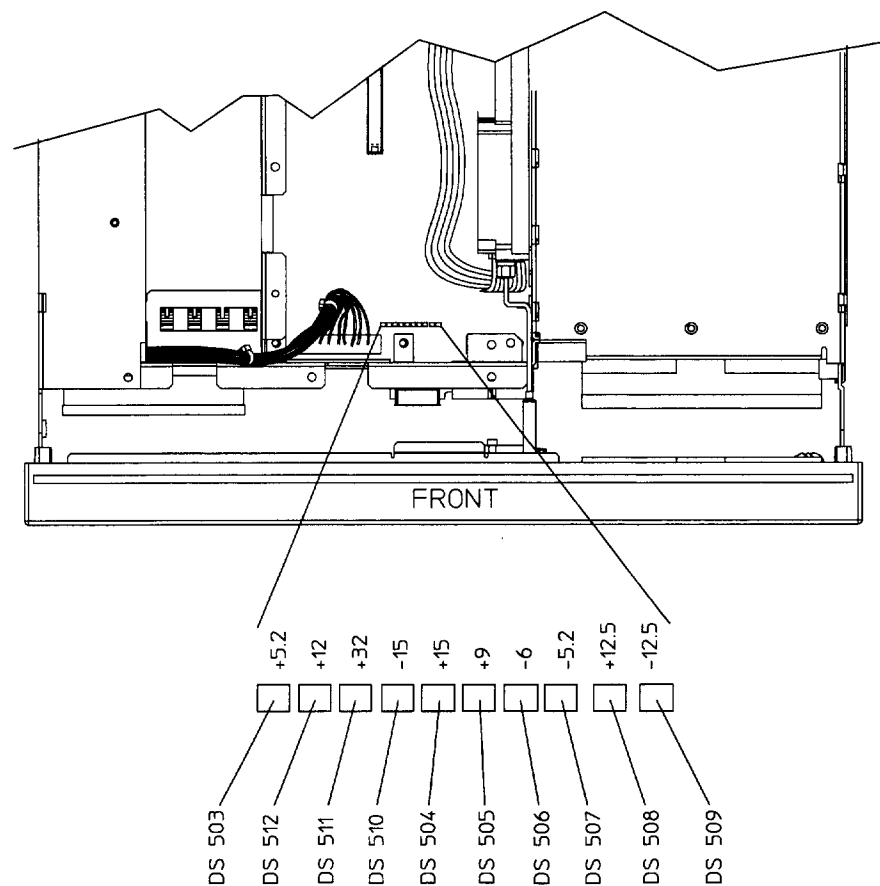

sk746b

Step 5: Measure the Individual Voltage Supplies

The voltages supplied as inputs from the power supply via J6 to the motherboard are +15 V (TP502), +15 V standby (+15 V_STBY), -15 V (TP503), +12 V (TP505), and +5.2 V (TP302). DGND (TP301) is associated with these supplies.

The -6 V (TP508) and -5.2 V (TP509) supplies receive their input from the +5.2 V digital supply (5.2 VD at TP506). The +5.2 V digital line is filtered to prevent the switching power supply noise from being induced onto the +5.2 VD supply lines. The -6 V is a bias voltage for circuits on the output board and other RF circuitry. The -5.2 V is used by the emitter coupled logic (ECL) digital ICs. The LCD display driver voltage (VLCD), a -14 V to -24 V source, also receives input from the +5.2 VD supply.

The input to the +32 V supply (TP504) is the +12 V supply. The +32 V supply is used by the synthesizer/doubler assembly. This supply also includes an LC noise filter.

The +12.5 V regulated supply (TP510) originates from the +15 V input. The -12.5 V regulated supply (TP511) originates from the -15 V input. These two supplies are used by the solid-state attenuator and the reverse power protection (RPP). The +10 V reference (TP501) originates from the +15 V input. The +9 V supply (TP507) originates from the +10 V reference and the +12 V supply.

1. Unplug the signal generator and turn it upside-down.
2. Expose the motherboard by removing the bottom cover. It is secured by 15 screws.
3. Plug in the signal generator.
4. Measure the voltage of each supply to verify they are within the tolerances listed in Table 1-3. The voltage supply test point locations are shown in Figure 1-4. If all the voltages are within tolerance, proceed to "Step 7: Check for Basic CPU Functionality".

Table 1-3 Voltage Supply Tolerances

Test Point	Supply Voltage	Tolerance
J6 (pins 2, 3, 12, 13)	+5.2 V	+/- 3%
J6 (pin 20)	+15 V	+/- 3%
J6 (pin 18)	-15 V	+/- 3%
J6 (pin 19)	+12 V	+/- 3%
J6 (pin 17)	+15 V_STBY	+/- 5%
TP301	DGND	N/A
TP302	+5.2 V	+/- 3%
TP501	+10 V_REF	+/- 3%
TP502	+15 V	+/- 3%
TP503	-15 V	+/- 3%
TP504	+32 V	+/- 4%
TP505	+12 V	+/- 3%
TP506	+5.2 VD	+/- 4%
TP507	+9 V	+/- 4%
TP508	-6 V	+/- 4%
TP509	-5.2 V	+/- 4%
TP510	+12.5 V	+/- 4%
TP511	-12.5 V	+/- 4%

Figure 1-4 Motherboard Test Point Locations

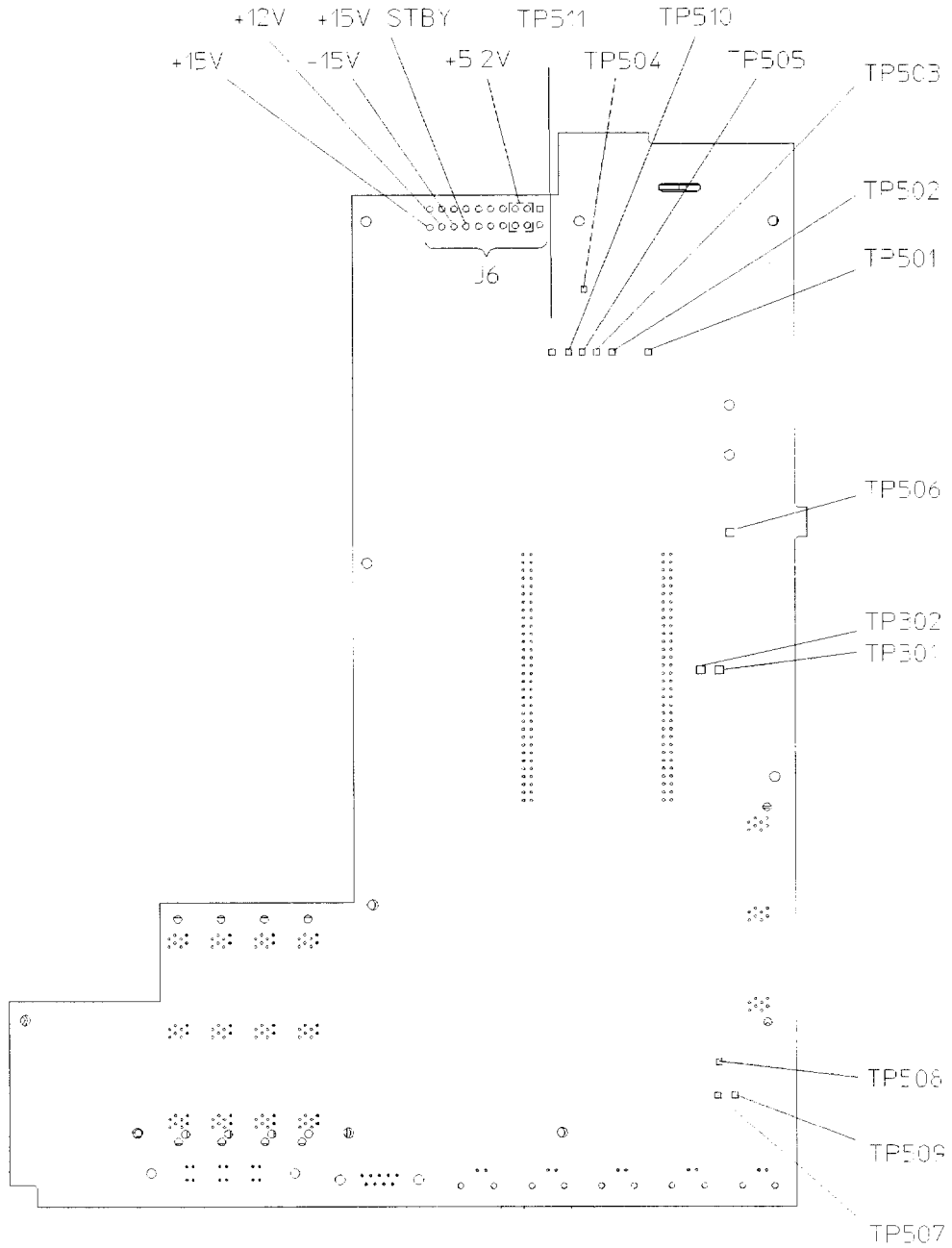

sk7114b

Step 6: Isolate the Failed Assembly

1. Switch off the signal generator.
2. Remove or disconnect an assembly. Below is a suggested order of removal/disconnection based upon ease.

For the ESG-A and ESG-D Series:

- a. A5 Dual Arbitrary Waveform Generator Board (Option UND)
- b. A6 Bit Error Rate Test Board (Option UN7)
- c. A7 Baseband Generator Board (Options UN3, UN4, UN8, UN9)
- d. A8 Data Generator Board (Options UN3, UN4, UN8, UN9)
- e. A21 Demodulator Board (Option 300)
- f. Front Panel - disconnect A1W1 ribbon cable
- g. A3 Inverter - disconnect A3W1
- h. A2 Display - disconnect W10
- i. AT1 Electronic Attenuator/RPP - disconnect W13
AT1 Mechanical Attenuator and A19 RPP (Option UNB) - disconnect W13 and A19W1
- j. A25 Pulse Modulator (Option 1E6) - disconnect A25W1
- k. B1 Fan - disconnect B1W1 (disconnect *only* temporarily)
- l. B2 Fan - disconnect B2W1 (disconnect *only* temporarily)
- m. A9 Output Board
- n. A11 Reference Board
- o. A12 Synthesizer/Doubler Board
- p. A20 YIG Down Convertor Assembly (Option 300) - disconnect W31

NOTE	Refer to Chapter 3, "Replaceable Parts (ESG-A and ESG-D Series)," for information on locating assemblies. Refer to Chapter 5, "Assembly Replacement," for information on removing or disconnecting assemblies.
-------------	--

For the ESG-AP and ESG-DP Series:

- a. A5 Dual Arbitrary Waveform Generator Board (Option UND)
- b. A6 Bit Error Rate Test Board (Option UN7)
- c. A7 Baseband Generator Board (Options UN3, UN4, UN8, UN9)
- d. A8 Data Generator Board (Options UN3, UN4, UN8, UN9)
- e. Front Panel - disconnect A1W1 ribbon cable
- f. A3 Inverter - disconnect A3W1

- g. A2 Display - disconnect W10
- h. AT1 Electronic Attenuator/RPP - disconnect W13
AT1 Mechanical Attenuator and A19 RPP (Option UNB) - disconnect W13 and A19W1
- i. A25 Pulse Modulator (Option 1E6) - disconnect A25W1
- j. B1 Fan - disconnect B1W1 (disconnect *only* temporarily)
- k. B2 Fan - disconnect B2W1 (disconnect only temporarily)
- l. A9 Output Board
- m. A11 Reference Board
- n. A23 Sampler Board
- o. A24 Frac-N/Divider Board
- p. A22 YIG Driver Assembly - disconnect W35

NOTE Refer to Chapter 4, "Replaceable Parts (ESG-AP and ESG-DP Series)," for information on locating assemblies. Refer to Chapter 5, "Assembly Replacement," for information on removing or disconnecting assemblies.

3. Switch on the signal generator and check the voltage supply LEDs (see Figure 1-3). If the LEDs are lit, you have likely identified the failed assembly. If one or more LEDs are still off, switch off the signal generator and replace/reconnect the assembly and repeat this procedure.

Step 7: Check for Basic CPU Functionality

The Digital Signal Processor (DSP) performs a self-diagnostic test at power up. If the DSP is not working, the CPU reports an error.

If the DSP does not seem to be working and the CPU did not report the error, then check the CLK_OUT signal at TP701. It should be a 16 MHz signal. (Refer to Figure 1-5.)

The eight LEDs of DS201 (see Figure 1-5) indicate the status of the boot and flash ROM for the CPU. The LEDs form a binary code that can be described as a two digit hexadecimal code. Table 1-4 shows the test sequence and the LED pattern (binary representation) of the test that is running. If an error occurs and the test is halted, the LED pattern will indicate which self test halted the process. The LED closest to R201 is the place holder for the Least Significant Bit (LSB) in the pattern.

Table 1-4 Sequence for DSP Self-Diagnostic Tests

Test Description	Hexadecimal Code	Binary Equivalent MSB LSB
LEDs at start of test	FF	1111 1111
Checksum test	FE	1111 1110
Bootrom RAM test	FD	1111 1101
RAM test	FC	1111 1100
I/O bus test	FB	1111 1011
Main firmware checksum test	FA	1111 1010
CPU test	AA	1010 1010
Test done and OK	00	0000 0000

Figure 1-5 Location of TP701 and DS201-208 on CPU/Motherboard

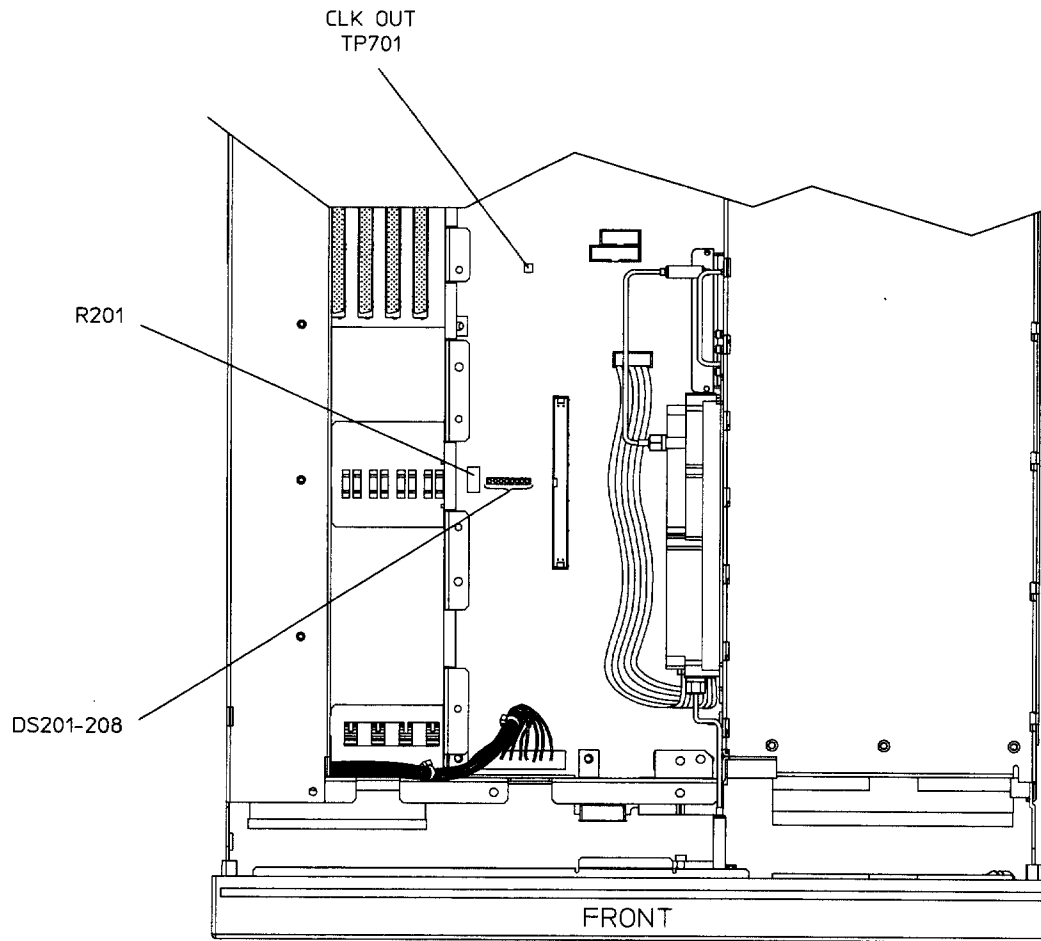

sk747b

Additional Information for Troubleshooting the ESG-AP and ESG-DP Series

Table 1-5 provides frequency-dependent settings for selected points in the RF signal flow of the ESG-AP and ESG-DP Series Signal Generators. Notice that the settings are relative to the RF output frequency. This information can improve your understanding of the signal generator circuitry, especially when used with the RF block diagram.

NOTE The values for Table 1-5 assume FM modulation is turned off.

Table 1-5 Frac-N, YO, and Other Selected Frequency-Dependent Settings for Several RF Output Frequencies

Freq Out (MHz)	Freq YO (MHz)	N	P	Frac-N (MHz)	F _{if} (MHz)	F _s (MHz)	Hi/Low	Output Divider
4000	8000	9	8	593.75000	37.1093750	884.7656250	High	2
3000	6000	7	10	644.53125	32.2265625	852.5390625	High	2
2271	4542	7	10	605.62500	30.2812500	644.5312500	Low	2
1500	6000	7	10	644.53125	32.2265625	852.5390625	High	4
1001	4004	5	10	685.46875	34.2734375	793.9453125	High	4
1000	8000	9	8	593.75000	37.1093750	884.7656250	High	8
700	5600	7	10	847.65625	42.3828125	793.9453125	High	8
300	4800	6	10	726.56250	36.3281250	793.9453125	High	16
240	6080	7	10	603.90625	30.1953125	864.2578125	High	8
100	7200	8	9	928.12500	51.5625000	893.5546875	High	8
1	7992	9	8	887.62500	55.4765625	881.8359375	High	8

ESG-A SERIES RF BLOCK DIAG (STANDARD & OPTION 1E6)

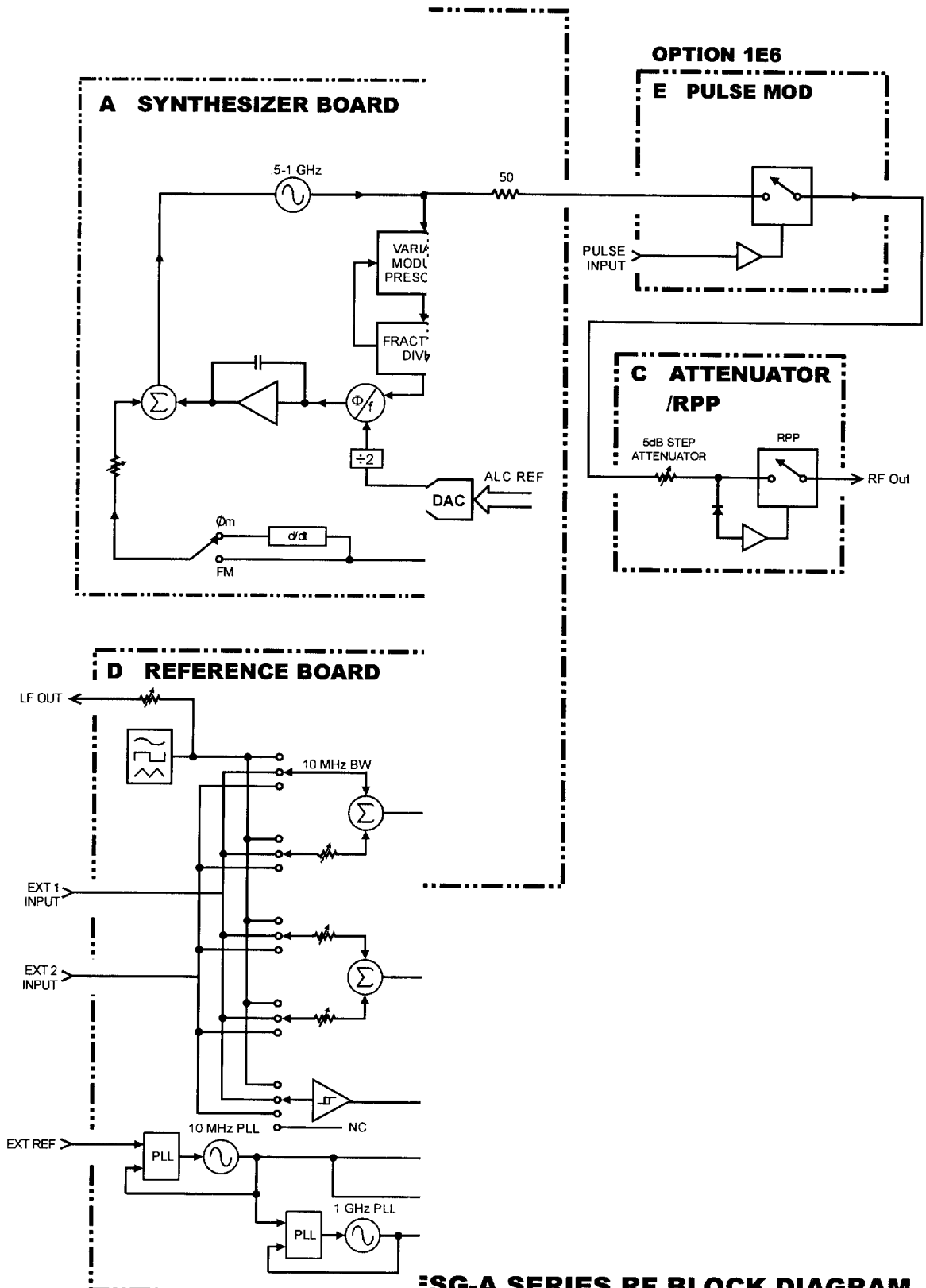

ESG-A SERIES RF BLOCK DIAGRAM
STANDARD & OPTION 1E6)

2 Assembly-Level Troubleshooting with Block Diagrams

This chapter provides the block diagrams and information necessary for you to test and troubleshoot the major assemblies of your signal generator.

Before You Begin Troubleshooting

Be sure to review the warning and caution statements described in Chapter 7 prior to troubleshooting your signal generator.

Using this Chapter with Service Software

Some block diagrams in this chapter are accompanied by a table for use with the automated service software that came with your signal generator. These tables list the signal generator's test conditions and the expected ABUS node voltages. The service software has a utility program which measures and displays the node voltages for each test. Refer to your signal generator's calibration guide for information on using the software.

The block diagrams and ABUS node tables are arranged in the following order:

- A5 Dual Arbitrary Waveform Generator Block Diagram (Option UND)
- A6 Bit Error Rate Test Block Diagram (Option UN7)
- A7 Baseband Generator Block Diagram (Options UN3 & UN4)
- A7 DBMIC Baseband Generator Block Diagram (Options UN8 & UN9)
- A8 Data Generator Block Diagram (Options UN3 & UN4)
- A8 Data Generator - Rev. A & B Block Diagram (Options UN8 & UN9)
- A8 Flex Data Generator - Rev. C & D Block Diagram (Options UN8 & UN9)
- A9 Output ABUS Nodes (ESG-A Series)
- A9 Output Block Diagram (ESG-A Series)
- A9 Output ABUS Nodes (ESG-D Series)
- A9 Output ABUS Nodes (ESG-AP, & ESG-DP Series)
- A9 Output Block Diagram (ESG-D, ESG-AP, & ESG-DP Series)
- A11 Reference ABUS Nodes (ESG-A & ESG-D Series)
- A11 Reference Block Diagram (ESG-A & ESG-D Series)
- A11 Reference ABUS Nodes (ESG-AP & ESG-DP Series)
- A11 Reference Block Diagram (ESG-AP & ESG-DP Series)
- A12 Synthesizer/Doubler ABUS Nodes (ESG-A & ESG-D Series)
- A12 Synthesizer/Doubler Block Diagram (ESG-A & ESG-D Series)
- A14 CPU/Motherboard ABUS Nodes

A14 CPU/Motherboard Block Diagram (1 of 2)
A14 CPU/Motherboard Block Diagram (2 of 2)
A20 Downconvertor Block Diagram (Option 300)
A21 Demodulator Block Diagram (Option 300)
A22 YIG Driver ABUS Nodes (ESG-AP & ESG-DP Series)
A22 YIG Driver Block Diagram (ESG-AP & ESG-DP Series)
A23 Sampler ABUS Nodes (ESG-AP & ESG-DP Series)
A23 Sampler Block Diagram (ESG-AP & ESG-DP Series)
A24 Frac-N/Divider ABUS Nodes (ESG-AP & ESG-DP Series)
A24 Frac-N/Divider Block Diagram (ESG-AP & ESG-DP Series)
AT1 Electronic Attenuator/RPP Block Diagram
AT1 Mechanical Attenuator and A19 RPP Block Diagram (Option UNB)
ESG-A Series Power Supply and Ground Interconnects Block Diagram
ESG-D Series Power Supply and Ground Interconnects Block Diagram (1 of 2)
ESG-D Series Power Supply and Ground Interconnects Block Diagram (2 of 2)
ESG-A Series Modulation and Signal Interconnects Block Diagram
ESG-D Series Modulation and Signal Interconnects Block Diagram (1 of 2)
ESG-D Series Modulation and Signal Interconnects Block Diagram (2 of 2)

A6 Bit Error Rate Test Block Diagram (Option UN7)

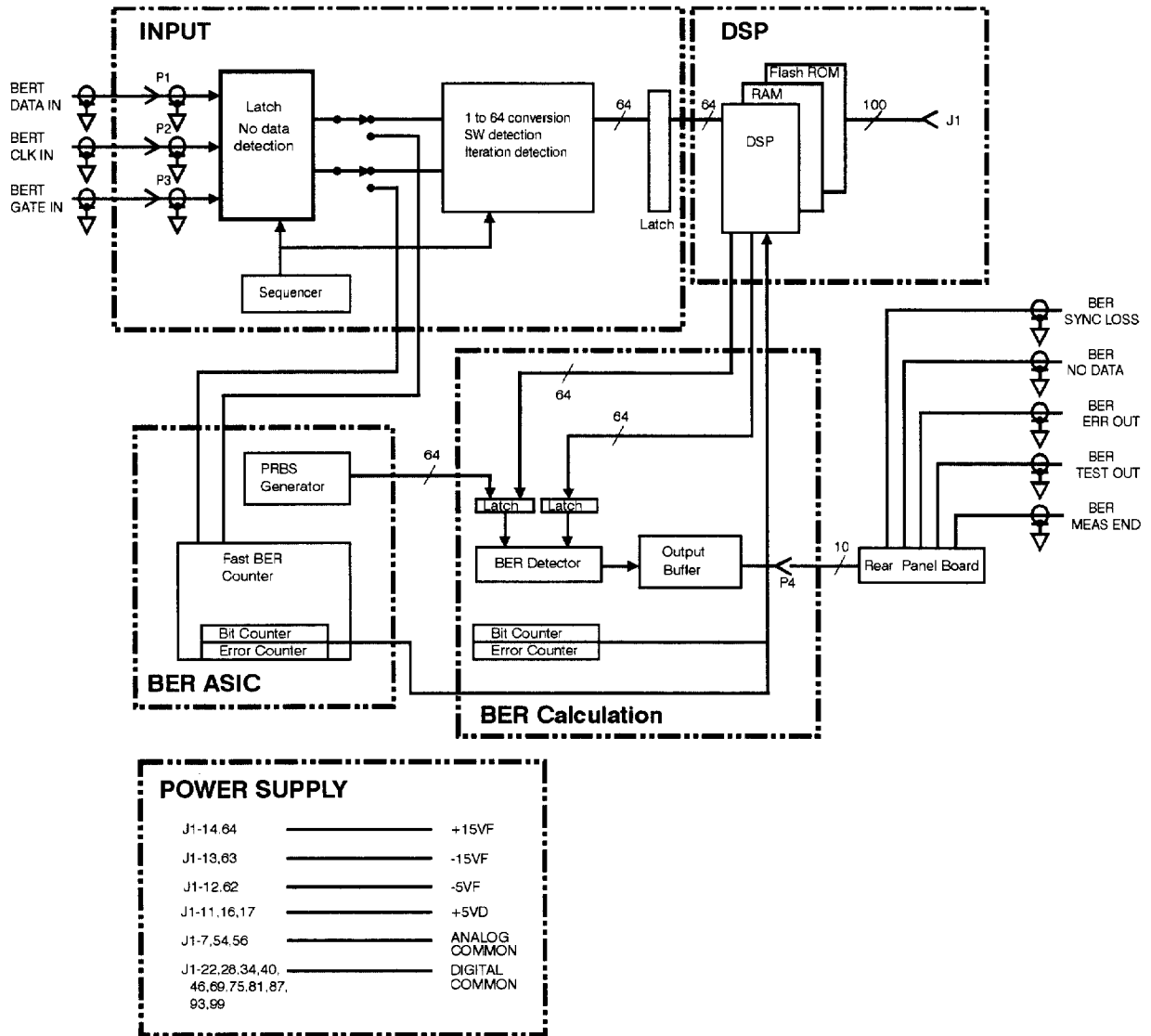

sk8001k

A8 Data Generator Block Diagram (Options UN3 & UN4)

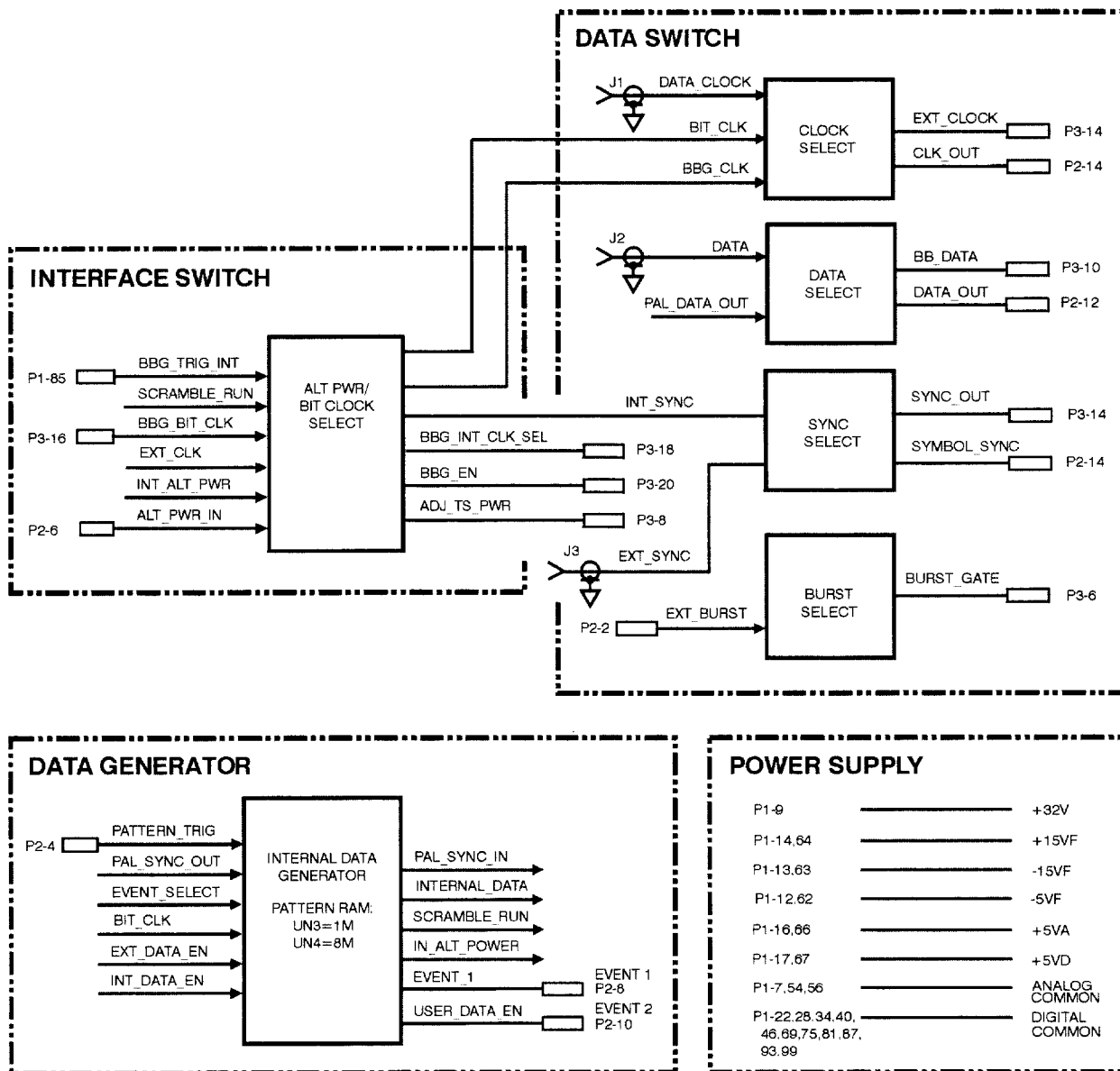

sk7119a

A8 Data Generator - Rev. A & B Block Diagram (Options UN8 & UN9)

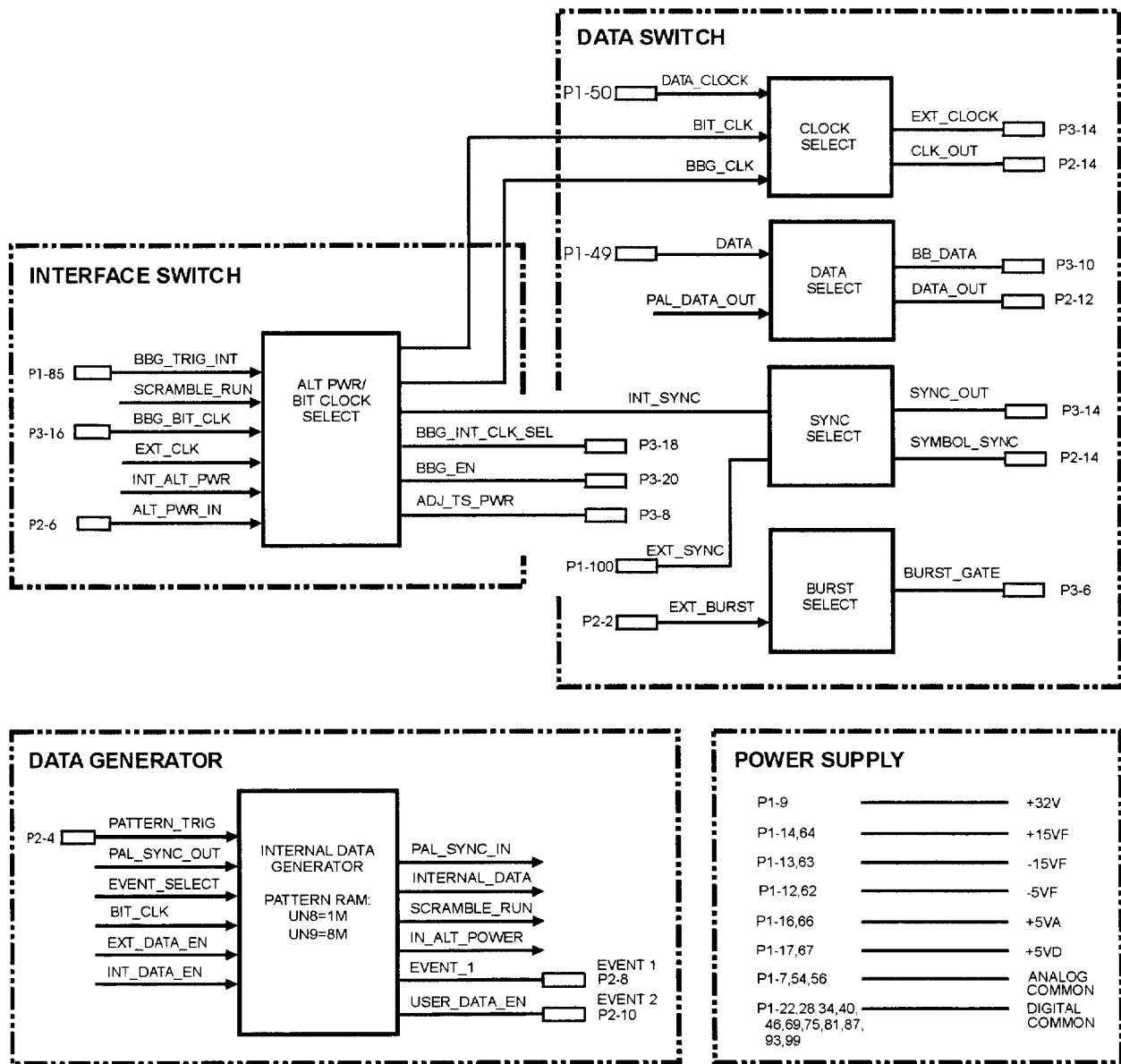

sk757b

A9 Output ABUS Nodes (ESG-A Series)

NOTE The node voltages given in the following table are approximate values based on a sample of signal generators. Your signal generator may not reflect these exact values. Additionally, the resolution of these values varies from node to node. As a guideline, interpret your measurements based on the number of decimal places shown for the expected voltage.

A9 Output ABUS Nodes (ESG-A Series) (1 of 2)

Test Conditions	Node Voltages (Corrected Values in Vdc)						
	ALC_MOD	BURST_MOD	ALC_DET	POW_REF_1	POW_REF_2	LOOP_INT	PTAT
PRESET; 0 dBm; RF On; No Modulation	~ 0.7	~ 19	~ -0.08	~ -1.2	~ -0.5	~ 1	~ 8.5 to 9.9
PRESET; 0 dBm; RF Off; No Modulation	~ 0.1	~ 19	0.0	~ -1.2	~ -0.5	~ -10	~ 8.5 to 9.9
PRESET; 20 dBm; RF On (Unleveled)	~ 20	~ 19	~ -0.4	~ -0.4	~ -1	~ 12	
Frequency Set to heterodyne Band; PRESET; Freq ≤ 249.9 MHz; 0 dBm; RF On; No Modulation	~ 0.4	~ 19	~ -0.05	~ -1.1	~ -0.3	~ 0.0	~ 8.5 to 9.9
+5.0 Vdc applied to Q INPUT: PRESET; 0 dBm; RF On; I/Q On; I/Q Source EXT I/Q; I Input = No Connection; Burst Envelope On; If -0.5Vdc is applied to Q INPUT, the Q node changes to negative voltage	~ 0.9 (20 w/ no Q Input)	~ 4.8	~ -0.08 (~ 0.1 w/ no Q Input)			~ 1.3 (~ 12 w/ no Q Input)	
+1 Vdc Applied to EXT 1 INPUT: PRESET; 0 dBm; RF On; AM On; AM Depth 100%; AM Source Ext 1 DC							

A9 Output ABUS Nodes (ESG-A Series) (2 of 2)

Test Conditions	Node Voltages (Corrected Values in Vdc)						
	I	Q	PRE_LEVEL	QUAD	GAIN_DET	GND	REF_AM
PRESET; 0 dBm; RF On; No Modulation	~ 0.8	~ 0	~ -2	~ -2	~ -0.2	~ 0.00	~ 0.3
PRESET; 0 dBm; RF Off; No Modulation	~ 0.8	~ 0	~ -2	~ -2	~ -0.2	~ 0.00	~ 0.3
PRESET; 20 dBm; RF On (Unleveled)							
Frequency Set to heterodyne Band; PRESET; Freq ≈ 249.9 MHz; 0 dBm; RF On; No Modulation	~ 0.5	~ 0	~ 2	~ -3	~ -0.2	~ 0.00	~ 0.2
+5.0 Vdc applied to Q INPUT: PRESET; 0 dBm; RF On; I/Q On; I/Q Source EXT I/Q; I Input = No Connection; Burst Envelope On; If -0.5Vdc is applied to Q INPUT, the Q node changes to negative voltage	~ 0	~ 0.8			~ 0.2 (0.0 w/ no Q Input)		
+1 Vdc Applied to EXT 1 INPUT: PRESET; 0 dBm; RF On; AM On; AM Depth 100%; AM Source Ext 1 DC							~ 1

A9 Output ABUS Nodes (ESG-D Series)

NOTE The node voltages given in the following table are approximate values based on a sample of signal generators. Your signal generator may not reflect these exact values. Additionally, the resolution of these values varies from node to node. As a guideline, interpret your measurements based on the number of decimal places shown for the expected voltage.

A9 Output ABUS Nodes (ESG-D Series) (1 of 2)

Test Conditions	Node Voltages (Corrected Values in Vdc)						
	ALC_MOD	BURST_MOD	ALC_DET	POW_REF_1	POW_REF_2	LOOP_INT	PTAT
PRESET; 0 dBm; RF On; No Modulation	~ 0.7	~ 19	~ -0.08	~ -1.2	~ -0.5	~ 1	~ 8.5 to 9.9
PRESET; 0 dBm; RF Off; No Modulation	~ 0.1	~ 19	0.0	~ -1.2	~ -0.5	~ -10	~ 8.5 to 9.9
PRESET; 20 dBm; RF On (Unleveled)	~ 20	~ 19	~ -0.4	~ -0.4	~ -1	~ 12	
Frequency Set to heterodyne Band; PRESET; Freq ≤ 249.9 MHz; 0 dBm; RF On; No Modulation	~ 0.4	~ 19	~ -0.05	~ -1.1	~ -0.3	~ 0.0	~ 8.5 to 9.9
+5.0 Vdc applied to Q INPUT: PRESET; 0 dBm; RF On; I/Q On; I/Q Source EXT I/Q; I Input = No Connection; Burst Envelope On; If -0.5Vdc is applied to Q INPUT, the Q node changes to negative voltage	~ 0.9 (20 w/ no Q Input)	~ 4.8	~ -0.08 (~ 0.1 w/ no Q Input)			~ 1.3 (~ 12 w/ no Q Input)	
+1 Vdc Applied to EXT 1 INPUT: PRESET; 0 dBm; RF On; AM On; AM Depth 100%; AM Source Ext 1 DC							

A9 Output ABUS Nodes (ESG-D Series) (2 of 2)

Test Conditions	Node Voltages (Corrected Values in Vdc)						
	I	Q	PRE_LEVEL	QUAD	GAIN_DET	GND	REF_AM
PRESET; 0 dBm; RF On; No Modulation	~ 0.8	~ 0	~ -2	~ -2	~ -0.2	~ 0.00	~ 0.3
PRESET; 0 dBm; RF Off; No Modulation	~ 0.8	~ 0	~ -2	~ -2	~ -0.2	~ 0.00	~ 0.3
PRESET; 20 dBm; RF On (Unleveled)							
Frequency Set to heterodyne Band; PRESET; Freq ≤ 249.9 MHz; 0 dBm; RF On; No Modulation	~ 0.5	~ 0	~ 2	~ -3	~ -0.2	~ 0.00	~ 0.2
+5.0 Vdc applied to Q INPUT: PRESET; 0 dBm; RF On; I/Q On; I/Q Source EXT I/Q; I Input = No Connection; Burst Envelope On; If -0.5Vdc is applied to Q INPUT, the Q node changes to negative voltage	~ 0	~ 0.8			~ 0.2 (0.0 w/ no Q Input)		
+1 Vdc Applied to EXT 1 INPUT: PRESET; 0 dBm; RF On; AM On; AM Depth 100%; AM Source Ext 1 DC							~ 1

A9 Output ABUS Nodes (ESG-AP, & ESG-DP Series)

NOTE The node voltages given in the following table are approximate values based on a sample of signal generators. Your signal generator may not reflect these exact values. Additionally, the resolution of these values varies from node to node. As a guideline, interpret your measurements based on the number of decimal places shown for the expected voltage.

A9 Output ABUS Nodes (ESG-AP & ESG-DP Series) (1 of 2)

Test Conditions	Node Voltages (Corrected Values in Vdc)						
	ALC_MOD	BURST_MOD	ALC_DET	POW_REF_1	POW_REF_2	LOOP_INT	PTAT
PRESET; 0 dBm; RF On; No Modulation; 50 Ω load on output	≈ 0.2 to 2 ^a	≈ 0.5 to 5 at ≤ 2.4 GHz; ≤ 20 at 4 GHz	-0.3	3.5	4.2	≈ -2 to 2 ^a (varies w/ freq)	9.5 (8.5 to 9.9)

a. These values will be > 10 V if ALC is unlevelled.

A9 Output ABUS Nodes (ESG-AP & ESG-DP Series) (2 of 2)

Test Conditions	Node Voltages (Corrected Values in Vdc)						
	I	Q	PRE_LEVEL	QUAD	GAIN_DET	GND	REF_AM
PRESET; 0 dBm; RF On; No Modulation; 50 Ω load on output	1.9	0	≈ -2 to 12 (varies w/ freq)	0.7	-0.35 to 0.02 at ≤ 2.4 GHz; 0.1 to 0.7 at > 2.4 GHz	0	≈ 0.6 (varies w/ freq & power level)

A11 Reference ABUS Nodes (ESG-A & ESG-D Series)

NOTE The node voltages given in the following table are approximate values based on a sample of signal generators. Your signal generator may not reflect these exact values. Additionally, the resolution of these values varies from node to node. As a guideline, interpret your measurements based on the number of decimal places shown for the expected voltage.

A11 Reference ABUS Nodes (ESG-A & ESG-D Series)

Test Conditions	Node Voltages (Corrected Values in Vdc)							
	MOD1_OUT	MOD2_OUT	VTUNE	MOD1_PK	MOD2_PK	LIN_AM	1GHZ_DET	FM_MOD
PRESET; No Modulation	0.00	0.00	2 to 4	< 0.5	< 0.5	0.00	0.0	< 0.3
Frequency Set to Heterodyne Band: PRESET; Freq ≤ 249.9 MHz; No Modulation			2 to 4				> 0.15	
+1 Vdc Applied to EXT 1 INPUT: PRESET; FM On; FM Source Ext 1 DC	~ -1.9	0.00	2 to 4	< 0.5	< 0.5		0.0	~ 2.2
+1 Vdc Applied to EXT 2 INPUT: PRESET; FM On; FM Source Ext 2 DC	~ 0	0.00	2 to 4	~ 7.5	< 0.5		0.0	~ 0
1 Vpp @ 1 kHz Applied to EXT 1 INPUT: PRESET; FM On; FM Source Ext 1 AC	~ -1.9	0.00	2 to 4	< 0.5	< 0.5	~ 2.0	0.0	
1 Vpp @ 1 kHz Applied to EXT 2 INPUT: PRESET; FM On; FM Source Ext 2 AC	~ 0	0.00	2 to 4	~ 7.5	< 0.5	~ 0	0.0	
+1 Vdc Applied to EXT 1 INPUT: PRESET; AM On; AM Depth 100%; AM Source Ext 1 DC	0.00	~ -1.9	2 to 4	< 0.5	< 0.5		0.0	~ 2.2
+1 Vdc Applied to EXT 2 INPUT: PRESET; AM On; AM Depth 100%; AM Source Ext 2 DC	0.00	~ 0	2 to 4	< 0.5	~ 7.5		0.0	~ 0
1 Vpp @ 1 kHz Applied to EXT 1 INPUT: PRESET; AM On; AM Depth 100%; AM Source Ext 1 AC	0.00	~ -1.9	2 to 4	< 0.5	< 0.5	~ 2.0	0.0	
1 Vpp @ 1 kHz Applied to EXT 2 INPUT: PRESET; AM On; AM Depth 100%; AM Source Ext 2 AC	0.00	~ 0	2 to 4	< 0.5	~ 7.5	~ 0	0.0	

A11 Reference ABUS Nodes (ESG-AP & ESG-DP Series)

NOTE The node voltages given in the following table are approximate values based on a sample of signal generators. Your signal generator may not reflect these exact values. Additionally, the resolution of these values varies from node to node. As a guideline, interpret your measurements based on the number of decimal places shown for the expected voltage.

A11 Reference ABUS Nodes (ESG-AP & ESG-DP Series)

Test Conditions	Node Voltages (Corrected Values in Vdc)							
	MOD1_OUT	MOD2_OUT	VTUNE	MOD1_PK	MOD2_PK	LIN_AM	1GHZ_DET	FM_MOD
PRESET; 0 dBm; RF On; No Modulation	- 0	- 0	7 to 27 (Fixed vs. Freq)	0.5	0.5	- 0	- 0.25 (< 250 MHz) - 0.02 (> 250 MHz)	< 0.3

A12 Synthesizer/Doubler ABUS Nodes (ESG-A & ESG-D Series)

NOTE The node voltages given in the following table are approximate values based on a sample of signal generators. Your signal generator may not reflect these exact values. Additionally, the resolution of these values varies from node to node. As a guideline, interpret your measurements based on the number of decimal places shown for the expected voltage.

A12 Synthesizer/Doubler ABUS Nodes

Test Conditions	Node Voltages (Corrected Values in Vdc)					
	F2	RF_OUT	TUNE	LOOP	10V	FM
PRESET; Freq 500.000001 MHz; No Modulation	~ 4	-0.4 to -0.7	3.0 to 4.8	~ -0.6	9.9 to 10.1	< 0.2
PRESET; Freq 750 MHz; No Modulation	~ 5.5	-0.4 to -0.7	10.2 to 12.8	~ -1.5	9.9 to 10.1	< 0.2
PRESET; Freq 1000 MHz; No Modulation	~ 7.2	-0.4 to -0.7	17.7 to 23.2	~ -5.5	9.9 to 10.1	< 0.2
+1 Vdc Applied to EXT 1 INPUT: PRESET; FM On; FM Source Ext 1 DC						~ -2.0
+1 Vdc Applied to EXT 1 INPUT: PRESET; Freq < 250 MHz; FM On; FM Source Ext 1 DC						~ -2.0

A14 CPU/Motherboard ABUS Nodes

NOTE The node voltages given in the following table are approximate values based on a sample of signal generators. Your signal generator may not reflect these exact values. Additionally, the resolution of these values varies from node to node. As a guideline, interpret your measurements based on the number of decimal places shown for the expected voltage.

A14 CPU/Motherboard ABUS Nodes

Test Conditions	Node Voltages (Corrected Values in Vdc)							
	DISP	LCD	INT_MOD	P10V_REF	M6V	M5V	P9V	ACOM
PRESET;		-7 ^a	0.00	10	-6.0	-5.2	9.0	0.00
PRESET; Vary Display Brightness 1 to 50	-0.4 to -1.3							

a. Approximately -5.3 V if jumpers for P104, P105, and P106 are set to negative position.

A20 Downconverter Block Diagram (Option 300)

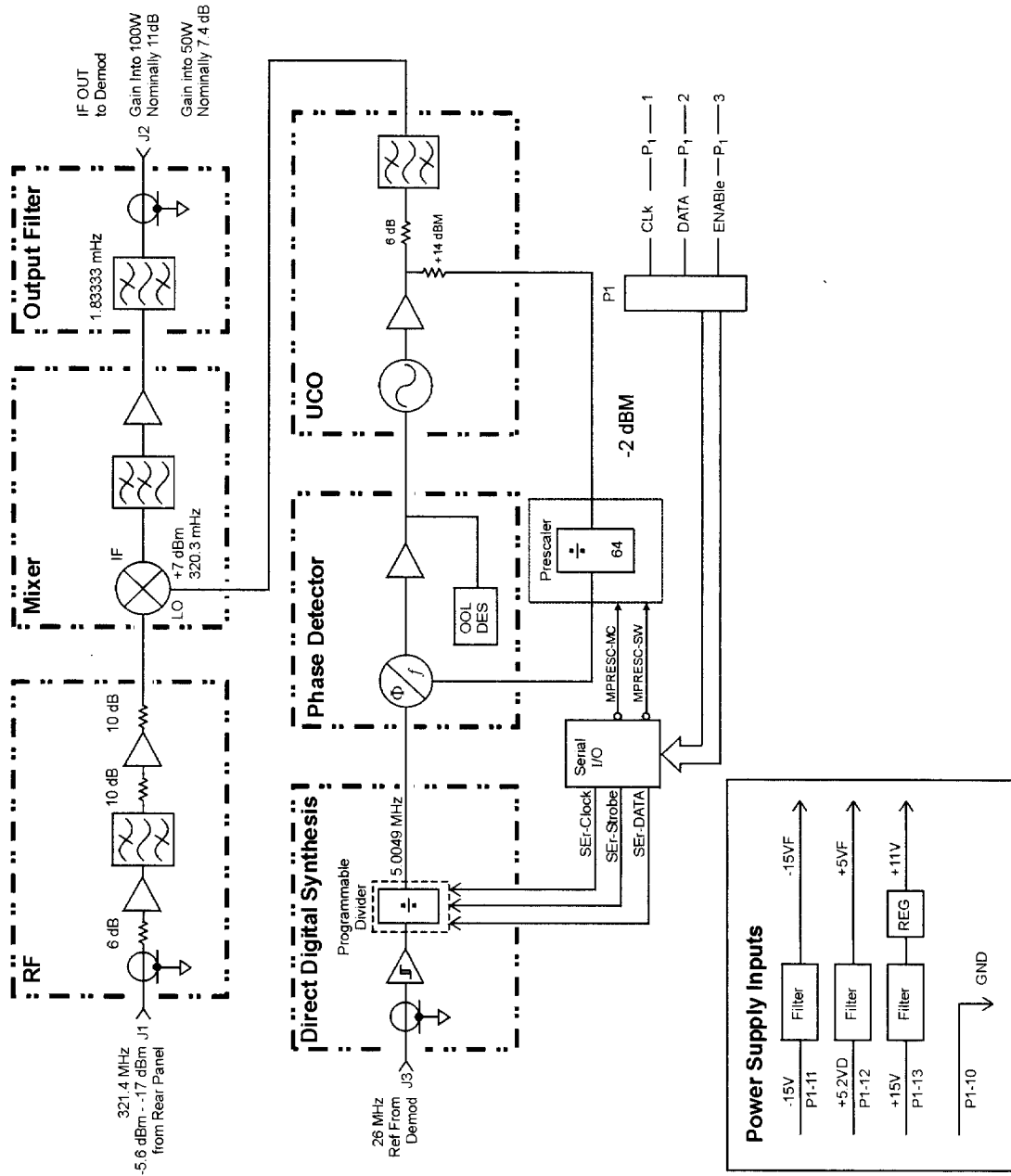

sk7111b

A22 YIG Driver ABUS Nodes (ESG-AP & ESG-DP Series)

NOTE The node voltages given in the following table are approximate values based on a sample of signal generators. Your signal generator may not reflect these exact values. Additionally, the resolution of these values varies from node to node. As a guideline, interpret your measurements based on the number of decimal places shown for the expected voltage.

A22 YIG Driver ABUS Nodes (ESG-AP & ESG-DP Series)

Test Conditions: PRESET; 0 dBm; RF On; No Modulation	Node Voltages (Corrected Values in Vdc)			
	FM_DRVVR	PLL_DRVVR	N5V	PRETUNE (-5.3 to 0.1)
	0	0	-5	
Freq 0.25 MHz				-4
Freq 750 MHz				-3
Freq 1 GHz				-4
Freq 1.001 GHz				-2
Freq 2 GHz				-4
Freq 2.5 GHz				-2.5
Freq 4 GHz				-4

A23 Sampler ABUS Nodes (ESG-AP & ESG-DP Series)

NOTE The node voltages given in the following table are approximate values based on a sample of signal generators. Your signal generator may not reflect these exact values. Additionally, the resolution of these values varies from node to node. As a guideline, interpret your measurements based on the number of decimal places shown for the expected voltage.

A23 Sampler ABUS Nodes (ESG-AP & ESG-DP Series)

Test Conditions: PRESET; 0 dBm; RF On; No Modulation	Node Voltages (Corrected Values in Vdc)						
	YO_PHSCLK	8V	P525V	P4_5	AGND	VCO_TUNE (5.5 to 12)	VCO_BIAS (4 to 7.5)
	~ -4 to 2 (varies w/ freq)	8	5	4.5	0		
Freq 0.25 MHz						10	6
Freq 750 MHz						9	5
Freq 1 GHz						10	6
Freq 1.001 GHz						7	5
Freq 2 GHz						10	6
Freq 2.5 GHz						8	5
Freq 4 GHz						10	6

A24 Frac-N/Divider ABUS Nodes (ESG-AP & ESG-DP Series)

NOTE The node voltages given in the following table are approximate values based on a sample of signal generators. Your signal generator may not reflect these exact values. Additionally, the resolution of these values varies from node to node. As a guideline, interpret your measurements based on the number of decimal places shown for the expected voltage.

A24 Frac-N/Divider ABUS Nodes

Test Conditions: PRESET; 0 dBm; RF On; No Modulation	Node Voltages (Corrected Values in Vdc)							
	RF_OUT	10V	FM	M10V	GND	F2	TUNE (3 to 23)	LOOP (-10 to 0)
	1 to 6	10	0.15	-10.0	0			-1 to -5 typical
Freq 0.25 MHz						3.6	6	
Freq 750 MHz						4	3 to 23	
Freq 1 GHz						3.8	7	
Freq 1.001 GHz						4.1	10	
Freq 2 GHz						3.8	7	
Freq 2.5 GHz						4.7	3 to 23	
Freq 4 GHz						3.8	7	

AT1 Electronic Attenuator/RPP Block Diagram

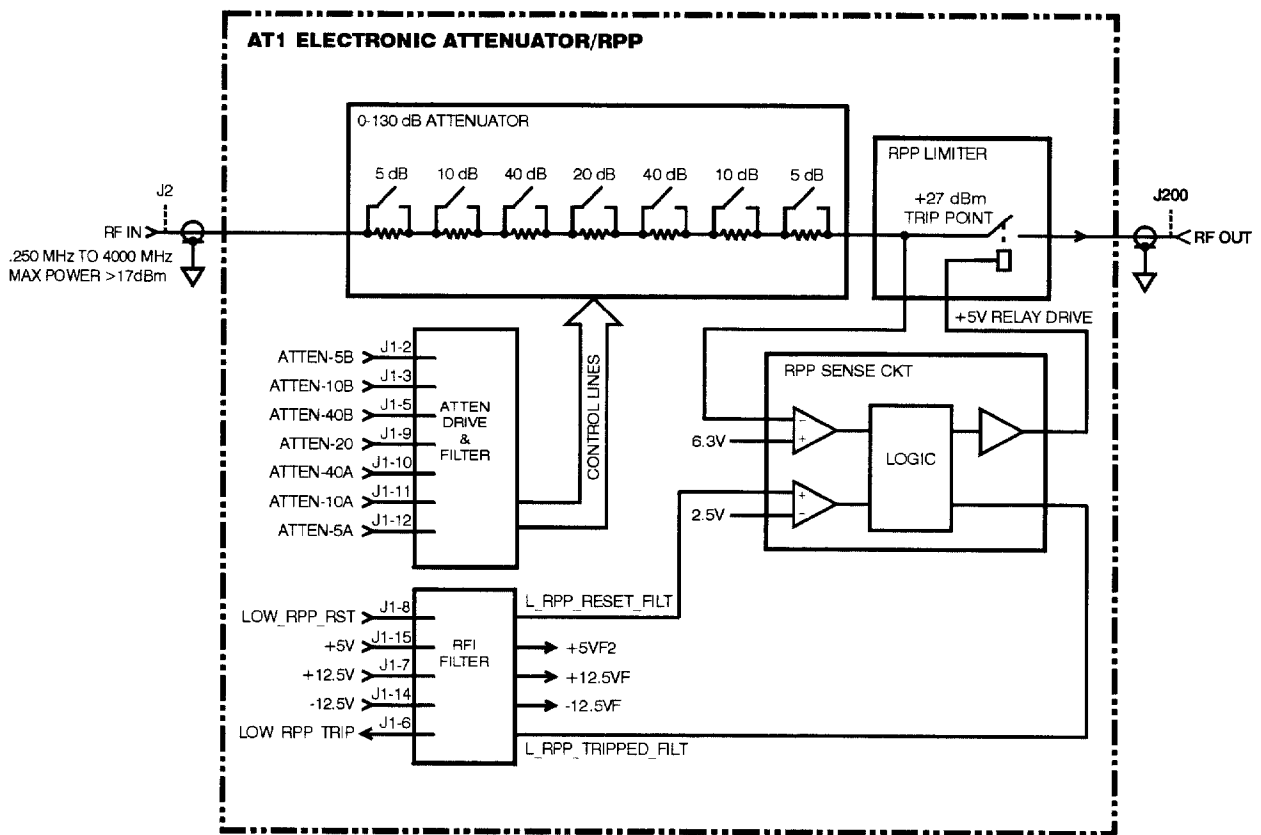

sk7112b

AT1 Mechanical Attenuator and A19 RPP Block Diagram (Option UNB)

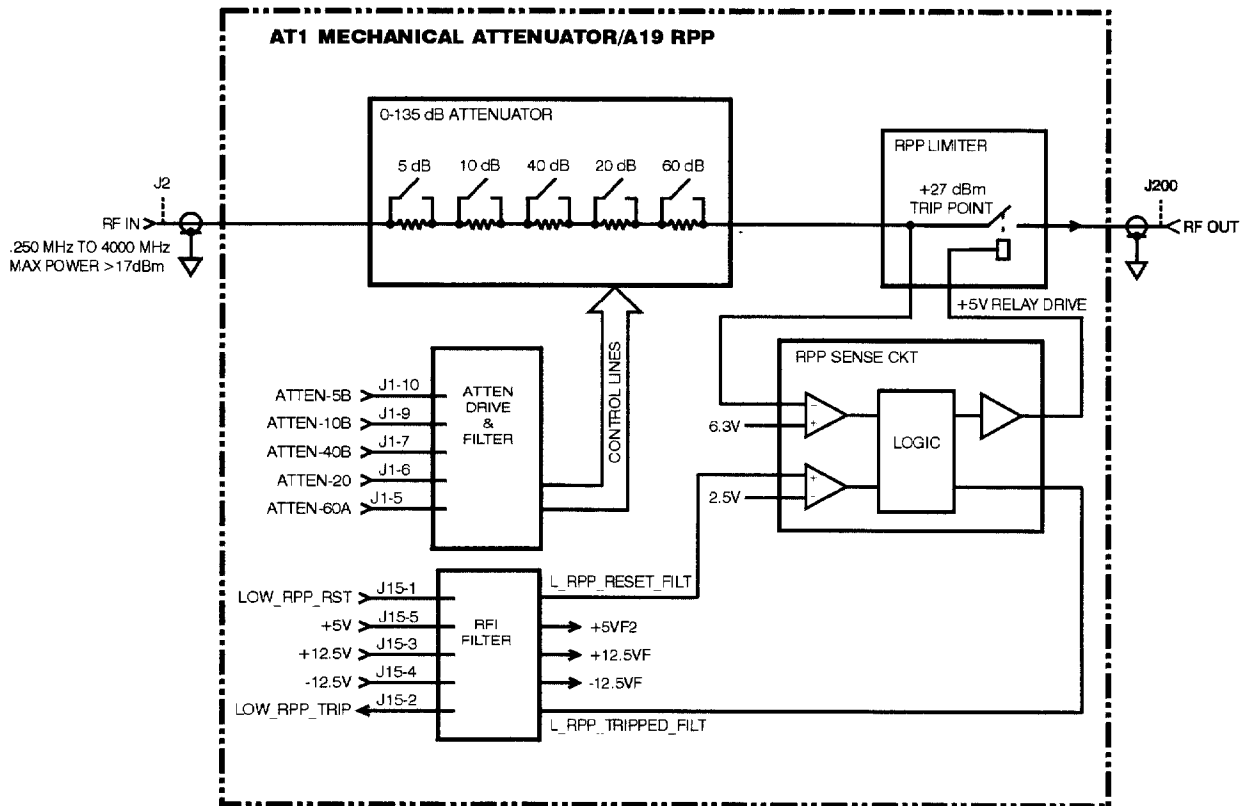

sk7113b

3 Replaceable Parts (ESG-A and ESG-D Series)

This chapter provides important ordering information and lists the part numbers for the various replaceable parts, kits, and accessories available for your signal generator. This chapter is also useful for locating and identifying assemblies and cables.

Ordering Information

To order a part listed in the replaceable parts lists, do the following:

1. Determine the part number.
2. Determine the quantity required.
3. Mail this information to the nearest Agilent Technologies office or, in the U.S., call the hotline number listed in the following section.

To order a part not listed in the replaceable parts lists, mail the following information to the nearest Agilent Technologies office or, in the U.S., call the hotline number listed in the following section.

1. the instrument model number
2. the serial number and options, if any (see rear panel)
3. a description of the part
4. a description of the part's function
5. the quantity required

Call (800) 227-8164 to Order Parts Fast (U.S. Only)

When you have gathered the information required to place an order, contact Agilent Technologies' direct ordering team by calling the toll-free hotline number shown above. Orders may be placed Monday through Friday, 6 AM to 5 PM (Pacific Standard Time).

The parts specialists have direct on-line access to replacement parts inventory corresponding to the replaceable parts lists in this manual. Four day delivery time is standard; there is a charge for hotline one-day delivery.

This information applies to the United States only. Outside the United States, you must contact the nearest Agilent Technologies sales and service office. (Refer to Table 1-1 on page 1-8.)

Save Money with Rebuilt-Exchange Assemblies

Under the rebuilt-exchange assembly program, certain factory-repaired and tested assemblies are available on a trade-in basis. These assemblies cost less than a new assembly, and meet all factory specifications required of a new assembly.

The defective assembly must be returned for credit under the terms of the rebuilt-exchange assembly program. The figure below illustrates the assembly exchange procedure in flowchart format.

Assembly Exchange Procedure

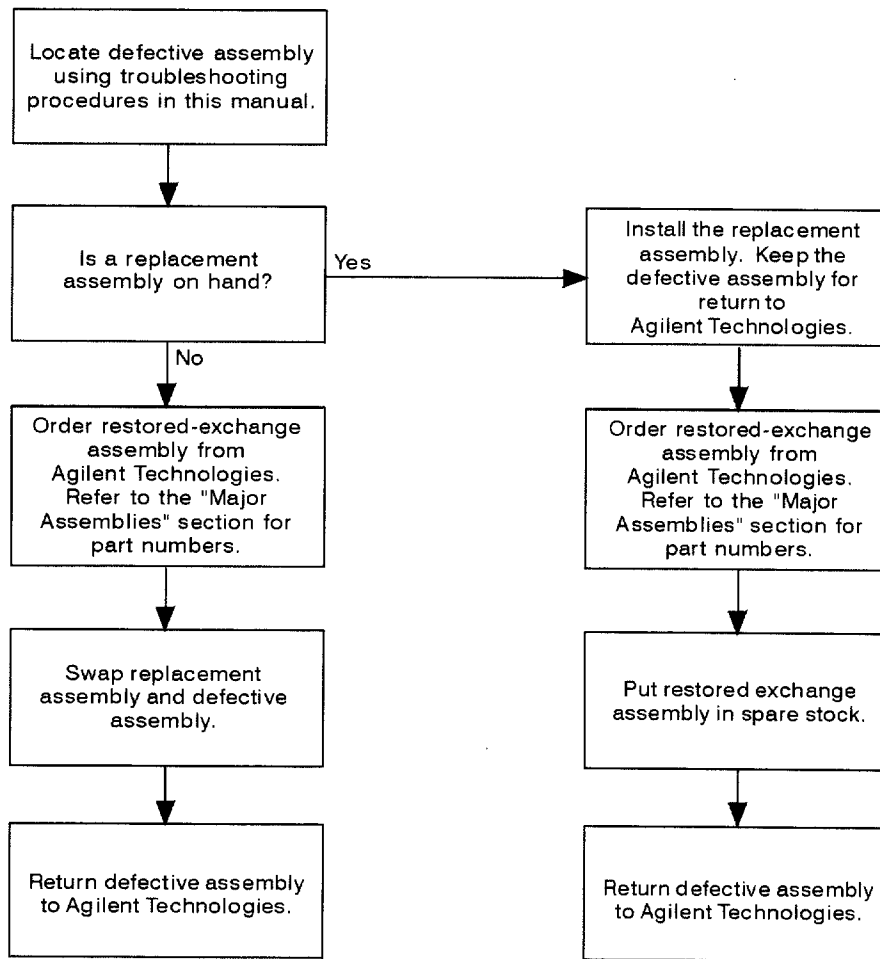

Shipping the Defective Assembly Back to Agilent Technologies

1. When you receive the rebuilt assembly, be careful not to damage the box in which it was shipped. You will use that box to return the defective assembly. The box you receive should contain the following:
 - the rebuilt assembly
 - an exchange assembly failure report
 - a return address label
2. Complete the failure report.
3. Place the failure report and the defective assembly in the box. Be sure to remove the enclosed return address label.
4. Seal the box with tape.

If you are inside the United States, stick the preprinted return address label over the label that is already on the box and return the box to Agilent Technologies. (Agilent Technologies pays postage on boxes mailed within the United States.)

If you are outside the USA, do not use the return address label; instead, address the box to the nearest Agilent Technologies sales and service office. (Refer to Table 1-1 on page 1-8.)

Abbreviations Used in Part Descriptions

This section defines the reference designators, abbreviations, and option numbers that are used in the part descriptions throughout this chapter.

Reference Designations

Reference Designator	Definition
A	assembly
AT	attenuator
B	fan
DS	lamp
J	electrical connector; jack
P	electrical connector; plug
W	cable; transmission path; wire

Abbreviations

Abbreviation	Definition
Assy	assembly
Bd	board
BC	beryllium
BN	buttonhead (screws)
CPU	central processing unit
CW	conical washer (screws)
CY	copper
D	diameter
ESD	electrostatic discharge
EXT	external
FL	flathead (screws)
Ft	feet
Hex	hexagonal
GPIB	general purpose interface bus
HX	hexagonal recess (screws)
I	in-phase
ID	inside diameter
L	length

Abbreviations Used in Part Descriptions

Abbreviation	Definition
LF	low frequency
M	meters or metric hardware
OD	outside diameter
PC	patch lock (screws) or printed circuit
PN	panhead (screws)
Q	quadrature
Qty	quantity
REF	reference
RF	radio frequency
RFI	radio frequency interference
RPP	reverse power protection
SH	socket head cap (screws)
SMA	subminiature type-A
SMB	subminiature type-B
TX	TORX recess (screws)
V	volt

Options

Options	Definition
300	Base Station BERT Extension for Option UN7
1E5	Precision Frequency Reference
1E6	High Performance Pulse Input
1EM	Rear Panel Connections
UN3	Baseband Generator - 1 Meg
UN4	Baseband Generator - 8 Meg
UN7	Bit Error Rate Test
UN8	Real-Time I/Q Baseband Generator - 1 Meg
UN9	Adds 7 Meg RAM to UN8
UNA	Alternate Timeslot Power
UNB	High Power with Mechanical Attenuator
UND	Dual Arbitrary Waveform Generator

Major Assemblies

This section lists part numbers for the major assemblies in your signal generator. The following instrument views are provided to help you locate specific assemblies.

- “Top View” on page 3-8
- “Top View (ESG-D Series - Option 300)” on page 3-10
- “Right Side Assemblies” on page 3-12
- “Disassembled Front Panel View” on page 3-13
- “Inside Rear Panel View” on page 3-14

Top View

Refer to Table 3-1 and Figure 3-1.

Table 3-1 Top View

Reference Designator	Part Number	Qty	Description
A4	0950-2791	1	Assy-Power Supply
A5	E4400-60187	1	Bd Assy-Dual Arbitrary Waveform Generator (Option UND)
A5	E4400-69187		Exchange Bd Assy-Dual Arbitrary Waveform Generator (Option UND)
A6	E4400-60072	1	Bd Assy-Bit Error Rate Test (Option UN7)
A6	E4400-69072		Exchange Bd Assy-Bit Error Rate Test (Option UN7)
A7	E4400-60048	1	Bd Assy-Baseband Generator (Options UN3, UN4)
A7	E4400-69048		Exchange Bd Assy-Baseband Generator (Options UN3, UN4)
A7	E4400-60070	1	Bd Assy-Real-Time I/Q Baseband Generator (Options UN8, UN8+UN9)
A7	E4400-69070		Exchange Bd Assy-Real-Time I/Q Baseband Generator (Options UN8, UN8+UN9)
A8	E4400-60043	1	Bd Assy-Data Generator, 1 Meg (Option UN3)
A8	E4400-69043		Exchange Bd Assy-Data Generator, 1 Meg (Option UN3)
A8	E4400-60057	1	Bd Assy-Data Generator, 8 Meg (Option UN4)
A8	E4400-69057		Exchange Bd Assy-Data Generator, 8 Meg (Option UN4)
A8	E4400-60182	1	Bd Assy-Data Generator, 1 Meg (Option UN8)
A8	E4400-69182		Exchange Bd Assy-Data Generator, 1 Meg (Option UN8)
A8	E4400-60183	1	Bd Assy-Data Generator, 8 Meg (Option UN8+UN9)
A8	E4400-69183		Exchange Bd Assy-Data Generator, 8 Meg (Option UN8+UN9)
A8	E4400-60154	1	Bd Assy-Flex Data Generator, 1 Meg (Option UN8)
A8	E4400-69154		Exchange Bd Assy-Flex Data Generator, 1 Meg (Option UN8)
A8	E4400-60195	1	Bd Assy-Flex Data Generator, 8 Meg (Option UN8+UN9)
A8	E4400-69195		Exchange Bd Assy-Flex Data Generator, 8 Meg (Option UN8+UN9)
A14	E4400-60220	1	Replacement Kit-CPU/Motherboard (serial no. prefixes < US3934/GB3934)
A14	E4400-60225	1	Replacement Kit-CPU/Motherboard (serial no. prefixes ≥ US3934/GB3934)
A14BT1	1420-0338	1	Battery-Lithium
AT1	E4400-60007	1	Assy-Electronic Attenuator/RPP
AT1	E4400-69007		Exchange Assy-Electronic Attenuator/RPP
AT1	E4400-60042	1	Assy-Electronic Attenuator/RPP (Option UNA)
AT1	33322-60014	1	Assy-Mechanical Attenuator (Option UNB)
A19	08648-60025	1	Assy-RPP (Option UNB)

Reference Designator	Part Number	Qty	Description
A25	08648-60010	1	Pulse Modulator Assembly (Option 1E6)
B1	3160-1040	1	Assy-Fan, Small
B2	E4400-60062	1	Kit-Fan, Large (includes 2 foam strips)

Figure 3-1 Top View

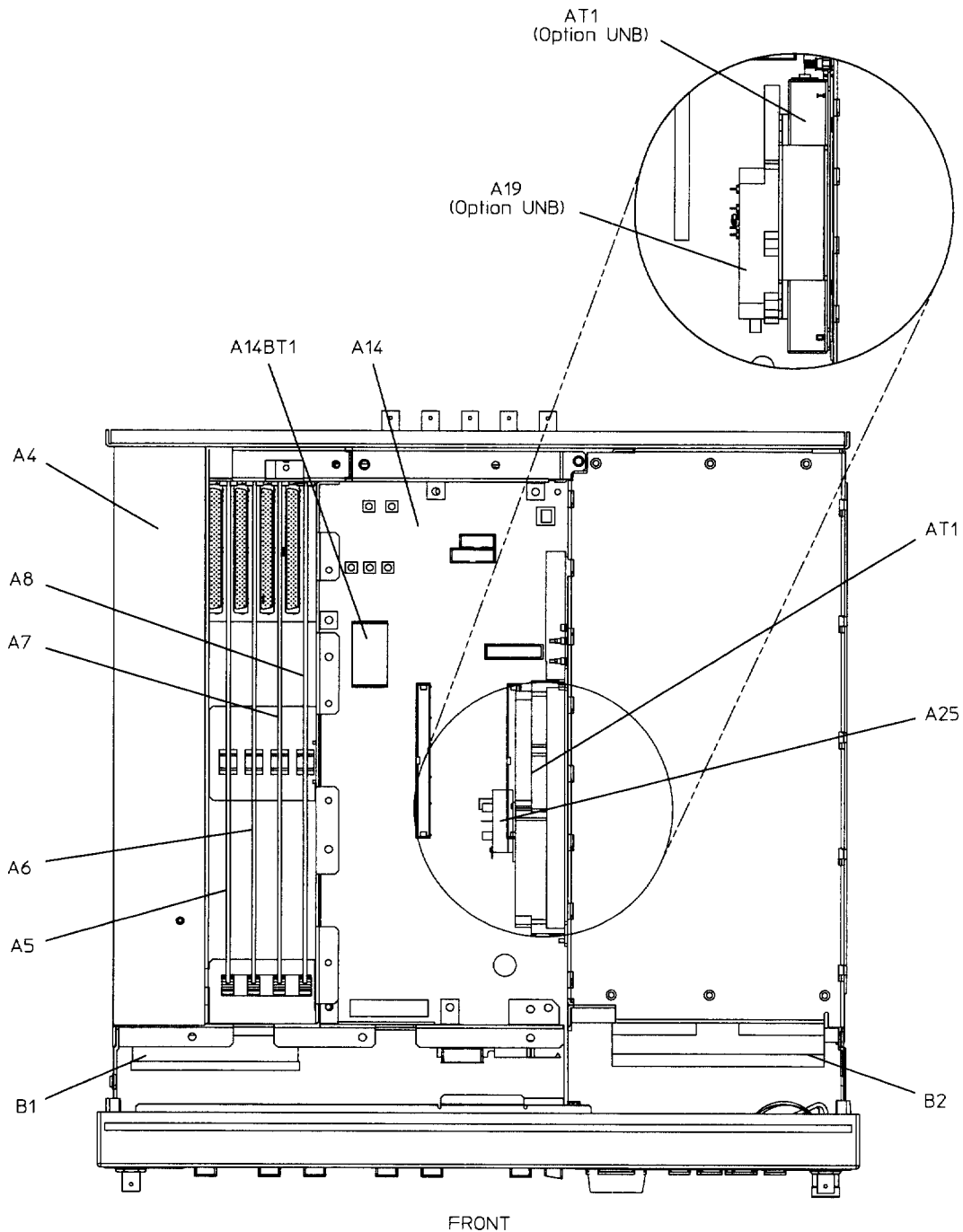

sk71b

Major Assemblies

Top View (ESG-D Series - Option 300)

Refer to Table 3-2 and Figure 3-2.

Table 3-2 Top View (ESG-D Series - Option 300)

Reference Designator	Part Number	Qty	Description
A4	0950-2791	1	Assy-Power Supply
A6	E4400-60072	1	Bd Assy-Bit Error Rate Test (Option UN7)
A6	E4400-69072		Exchange Bd Assy-Bit Error Rate Test (Option UN7)
A7	E4400-60070	1	Bd Assy-Real-Time I/Q Baseband Generator (Options UN8 or UN8+UN9)
A7	E4400-69070		Exchange Bd Assy-Real-Time I/Q Baseband Generator (Options UN8 or UN8+UN9)
A8	E4400-60154	1	Bd Assy-Flex Data Generator, 1 Meg (Option UN8)
A8	E4400-69154		Exchange Bd Assy-Flex Data Generator, 1 Meg (Option UN8)
A8	E4400-60195	1	Bd Assy-Flex Data Generator, 8 Meg (Option UN8+UN9)
A8	E4400-69195		Exchange Bd Assy-Flex Data Generator, 8 Meg (Option UN8+UN9)
A14	E4400-60220	1	Replacement Kit-CPU/Motherboard (serial no. prefixes < US3934/GB3934)
A14	E4400-60225	1	Replacement Kit-CPU/Motherboard (serial no. prefixes ≥ US3934/GB3934)
A14BT1	1420-0338	1	Battery-Lithium
AT1	E4400-60007	1	Assy-Electronic Attenuator/RPP
AT1	E4400-69007		Exchange Assy-Electronic Attenuator/RPP
AT1	E4400-60042	1	Assy-Electronic Attenuator/RPP (Option UNA)
A20	E4400-60200	1	Bd Assy-Downconverter
A20	E4400-69200	1	Exchange Bd Assy-Downconverter
A21	E4400-60199	1	Bd Assy-Demodulator
A21	E4400-69199		Exchange Assy-Demodulator
B1	3160-1040	1	Assy-Fan, Small
B2	E4400-60062	1	Kit-Fan, Large (includes 2 foam strips)

Figure 3-2 Top View (ESG-D Series - Option 300)

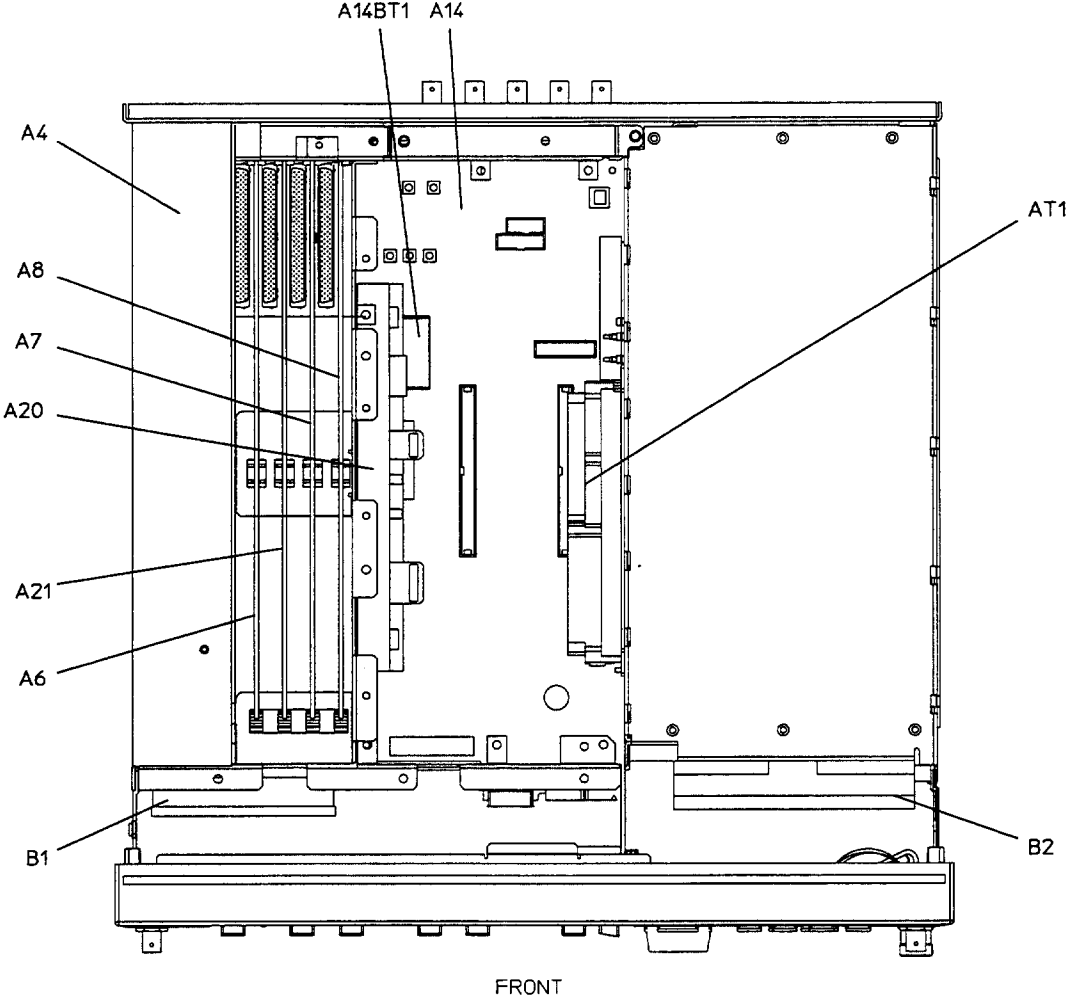

sk796b

Major Assemblies

Right Side Assemblies

Refer to Table 3-3 and Figure 3-3.

Table 3-3 Replaceable Assemblies, Right Side

Reference Designator	Part Number	Qty	Description
A9	E4400-60038	1	Bd Assy-Output (ESG-A series with serial no. prefixes \leq US3926/GB3926 or \geq US3934/GB3934)
A9	E4400-69038	1	Exchange Bd Assy-Output (ESG-A series with serial no. prefixes \leq US3926/GB3926 or \geq US3934/GB3934)
A9	E4400-60003	1	Bd Assy-Output (ESG-A series with serial no. prefix US3927/GB3927)
A9	E4400-69003	1	Exchange Bd Assy-Output (ESG-A series with serial no. prefix US3927/GB3927)
A9	E4400-60003	1	Bd Assy-Output (ESG-D Series)
A9	E4400-69003	1	Exchange Bd Assy-Output (ESG-D Series)
A9	E4400-60141	1	Bd Assy-Output (<i>All</i> models with Option UNB)
A9	E4400-69141	1	Exchange Bd Assy-Output (<i>All</i> models with Option UNB)
A11	E4400-60243	1	Bd Assy-Reference, TCXO
A11	E4400-69243	1	Exchange Bd Assy-Reference, TCXO
A11	E4400-60242	1	Bd Assy-Reference, OCXO (Option 1E5)
A11	E4400-69242	1	Exchange Bd Assy-Reference, OCXO (Option 1E5)
A12	E4400-60180	1	Bd Assy-Synthesizer/Doubler
A12	E4400-69180	1	Exchange Bd Assy-Synthesizer/Doubler
A15	E4400-60138	1	Bd Assy-Daughter

Figure 3-3 Right Side View

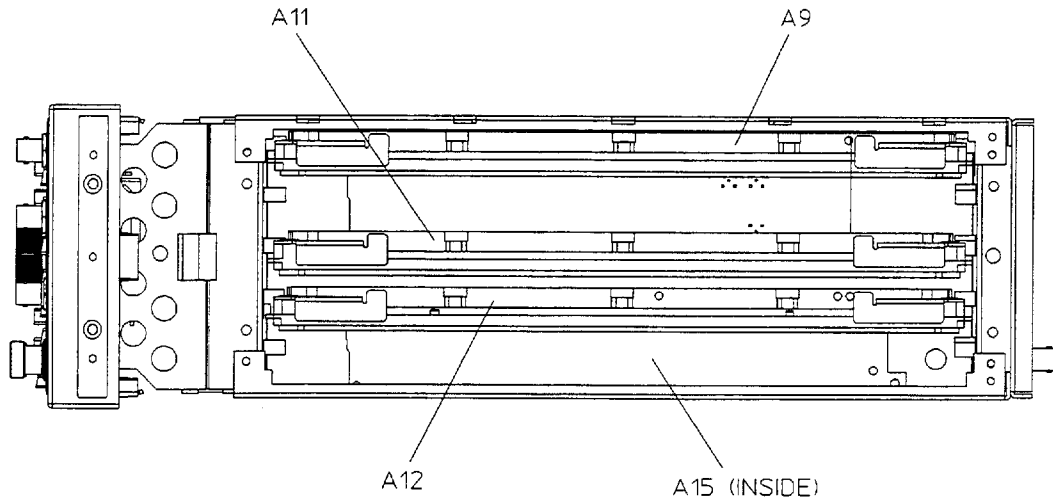

sk714a

Disassembled Front Panel View

Refer to Table 3-4 and Figure 3-4.

Table 3-4 Disassembled Front Panel View

Reference Designator	Part Number	Qty	Description
A1	E4400-60211	1	Bd Assy-Front Panel
A2	1990-1910	1	Assy-Display, Wide-Angle View (serial no. prefixes < US3934/GB3934)
A2	2090-0375	1	Assy-Display, Wide-Angle View (serial no. prefixes ≥ US3934/GB3934)
A2DS1	1513-5204	1	Lamp-Fluorescent
A3	0950-3093	1	Assy-Inverter

Figure 3-4 Disassembled Front Panel View

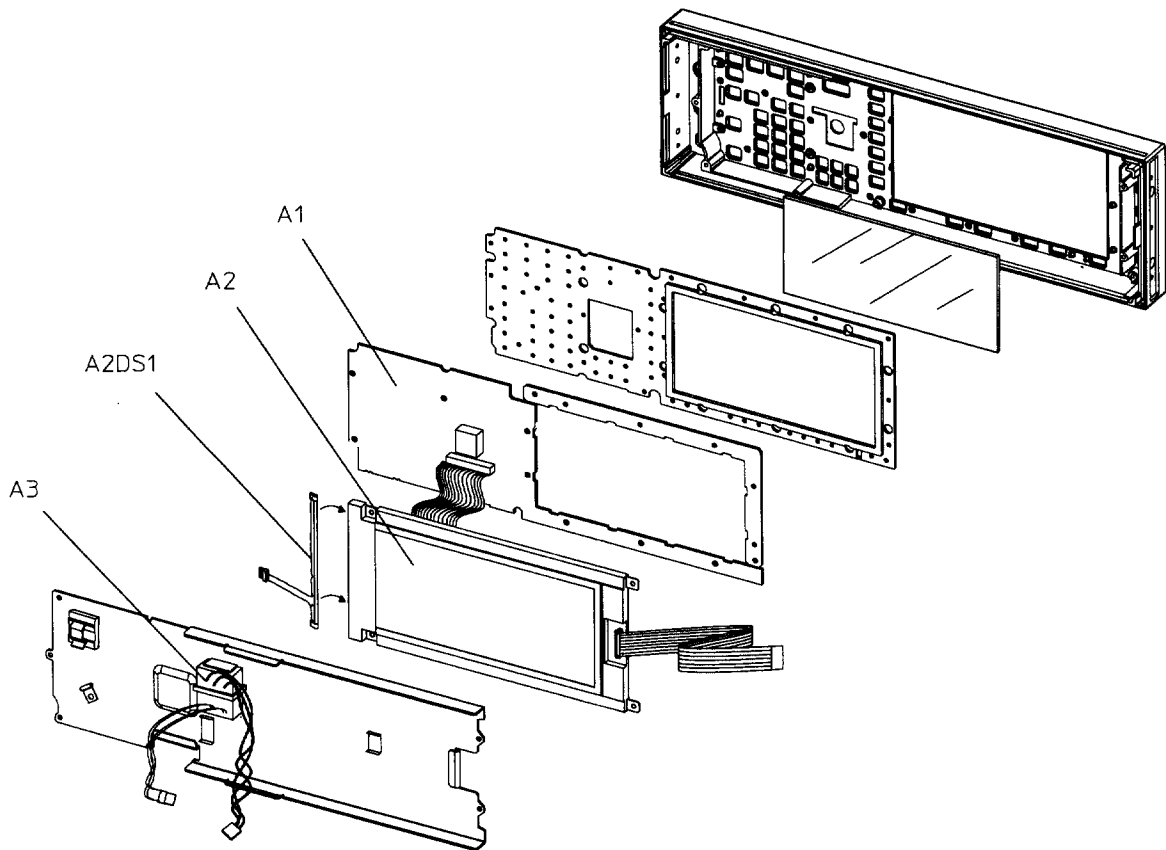

sk7147b

Inside Rear Panel View

Refer to Table 3-5 and Figure 3-5.

Table 3-5 Inside Rear Panel View

Reference Designator	Part Number	Qty	Description
A16	5063-9711	1	Assy-Line Module
A17	E4400-60145	1	Bd Assy-Rear Panel Interface (ESG-D Series)
A17	E4400-60146	1	Bd Assy-Rear Panel Interface (ESG-D Series Option 1EM)
A18	E4400-60075	1	Bd Assy Rear Panel Interface Subminiature Type-B (ESG-D Series Option UN7)

Figure 3-5 Inside Rear Panel View

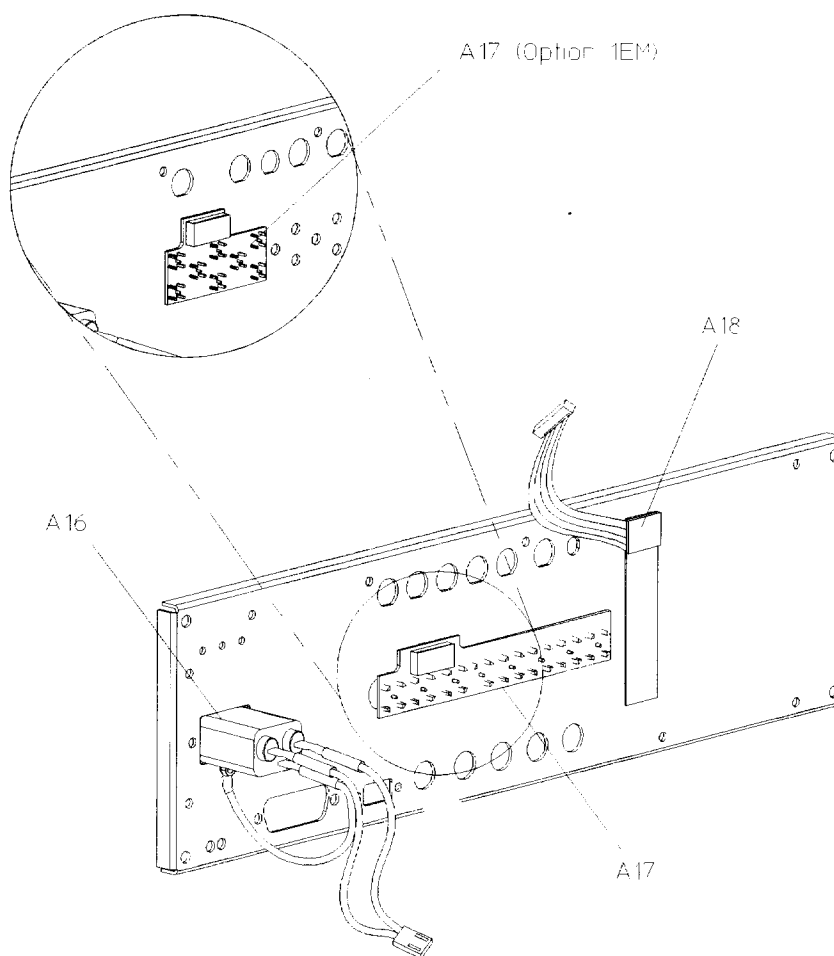

sk72b

Cables

This section lists part numbers for the cables in your signal generator. The following instrument views are provided to help you locate specific cables.

- “Top View (ESG-A Series)” on page 3-16
- “Top View (ESG-D Series - Options UN3/4, UN7)” on page 3-18
- “Top View (ESG-D Series - Options UN7, UN8)” on page 3-20
- “Top View (ESG-D Series - Option UND)” on page 3-22
- “Top View (ESG-D Series - Options UN3/4, UN7 with 1EM)” on page 3-24
- “Top View (ESG-D Series - Options UN7, UN8 with 1EM)” on page 3-26
- “Top View (ESG-D Series - Options UN7, UN8, UND)” on page 3-28
- “Top View (ESG-D Series - Option UND with 1EM)” on page 3-30
- “Top View (ESG-D Series - Option 300)” on page 3-32
- “Inside Front Panel View” on page 3-34
- “Electronic Attenuator/RPP View” on page 3-36
- “Electronic Attenuator/RPP View (with Option 1EM)” on page 3-38
- “Mechanical Attenuator View (Option UNB)” on page 3-40
- “Mechanical Attenuator View (Option UNB with 1EM)” on page 3-42
- “Pulse Modulator View (Option 1E6)” on page 3-44

Top View (ESG-A Series)

Refer to Table 3-6 and Figure 3-6.

Table 3-6 Top View (ESG-A Series)

Reference Designator	Part Number	Qty	Description
A4W1 ¹	(part of A4)	1	Power Supply (A4) to CPU/Motherboard (A14J6)
A16W1 ¹	(part of A16)	1	Line Module (A16) to Power Supply (A4J1)
A16W2 ¹	(part of A16)	1	Line Module (A16) to Chassis Ground Post on Rear Panel

1. This cable is not replaceable by itself. You must order the corresponding assembly.

Figure 3-6 Top View (ESG-A Series)

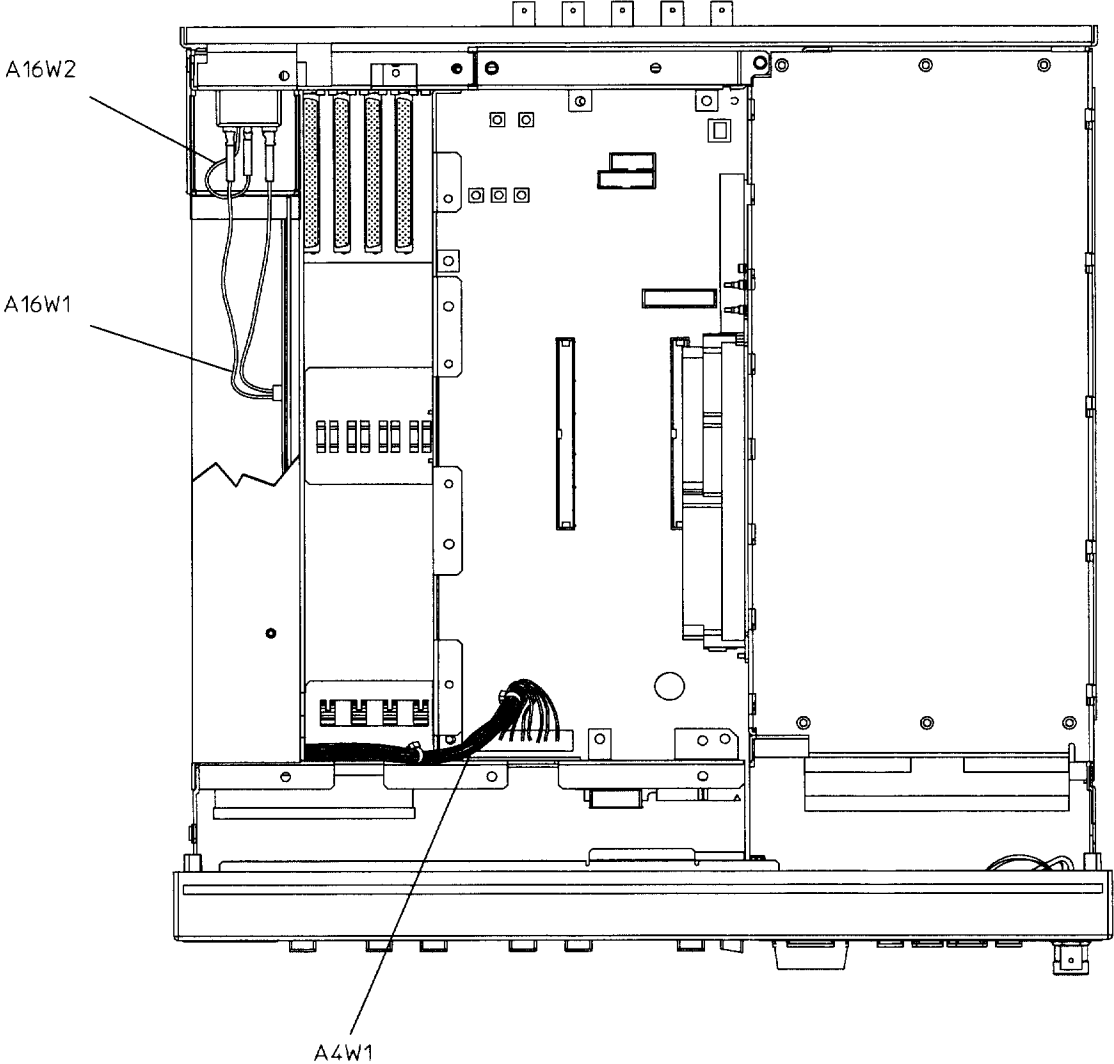

sk77b

Top View (ESG-D Series - Options UN3/4, UN7)

Refer to Table 3-7 and Figure 3-7.

Table 3-7 Top View (ESG-D Series - Options UN3/4, UN7)

Reference Designator	Part Number	Qty	Description
A4W1 ¹	(part of A4)	1	Power Supply (A4) to CPU/Motherboard (A14J6)
A16W1 ¹	(part of A16)	1	Line Module (A16) to Power Supply (A4J1)
A16W2 ¹	(part of A16)	1	Line Module (A16) to Chassis Ground Post on Rear Panel
A18W1 ¹	(part of A18)	1	BERT Rear Panel Interface Board (A18) to BERT (A6)
W3	8120-5063	1	DATA to Data Generator (A8J2)
W4	8120-5063	1	DATA CLOCK to Data Generator (A8J1)
W5	8120-5063	1	SYMBOL SYNC to Data Generator (A8J3)
W15	8120-5055	1	Baseband Generator (A7P403) to BASEBAND GENREF IN
W16	8120-5055	1	Baseband Generator (A7P404) to Rear Panel (Q OUT)
W17	8120-5055	1	Baseband Generator (A7P405) to Rear Panel (I OUT)
W18	8120-8458	1	Rear Panel Interface Board (A17) to Data Generator (A8P2) (Options UN3/4)
W19	8120-8349	1	Baseband Generator (A7P300) to Data Generator (A8P3) (Options UN3/4)
W21	8120-5055	1	Bit Error Rate Test Board (A6) to BER GATE IN (Options UN3/4 and UN7)
W22	8120-5055	1	Bit Error Rate Test Board (A6) to BER CLK IN (Options UN3/4 and UN7)
W23	8120-5055	1	Bit Error Rate Test Board (A6) to BER DATA IN (Options UN3/4 and UN7)

1. This cable is not replaceable by itself. You must order the corresponding assembly.

Figure 3-7 Top View (ESG-D Series - Options UN3/4, UN7)

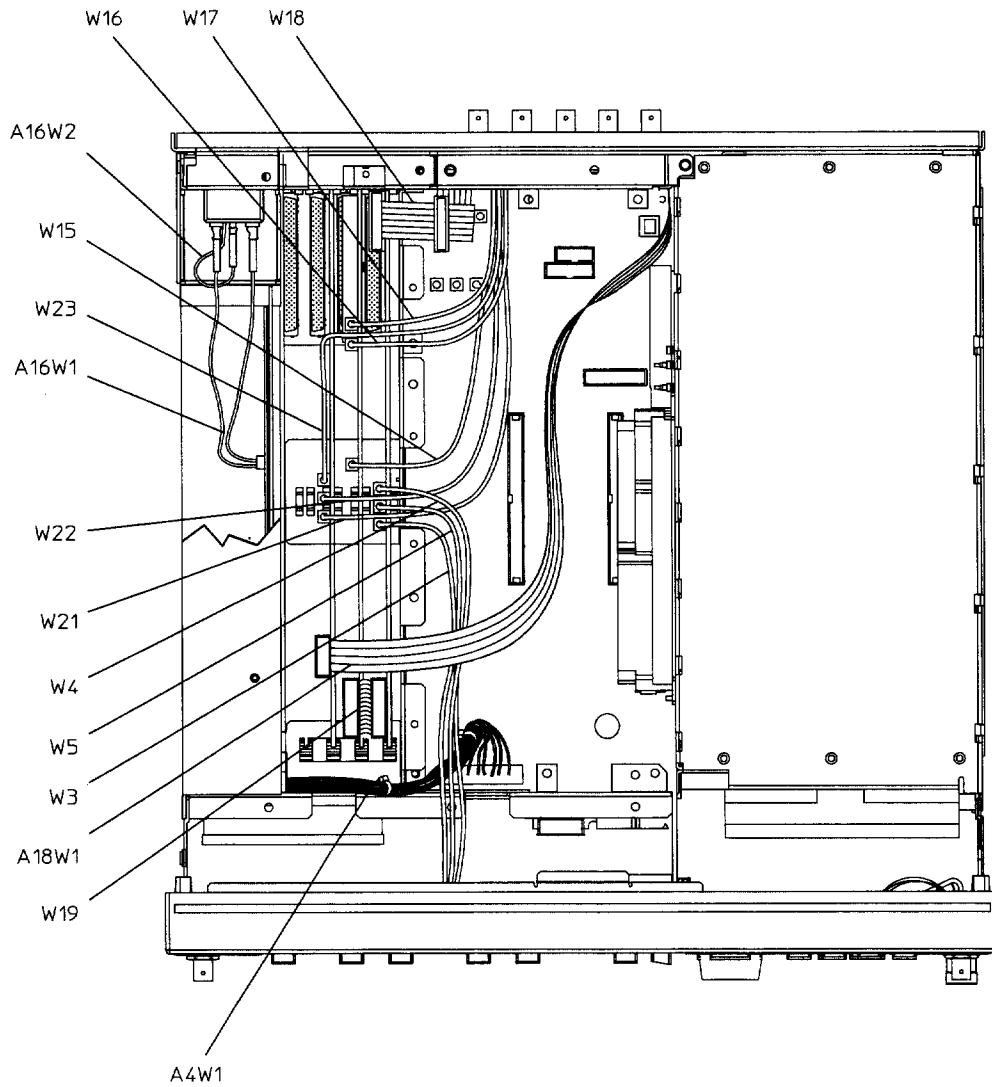

sk78b

Top View (ESG-D Series - Options UN7, UN8)

Refer to Table 3-8 and Figure 3-8.

Table 3-8 Top View (ESG-D Series - Options UN7, UN8)

Reference Designator	Part Number	Qty	Description
A4W1 ¹	(part of A4)	1	Power Supply (A4) to CPU/Motherboard (A14J6)
A16W1 ¹	(part of A16)	1	Line Module (A16) to Power Supply (A4J1)
A16W2 ¹	(part of A16)	1	Line Module (A16) to Chassis Ground Post on Rear Panel
A18W1 ¹	(part of A18)	1	BERT Rear Panel Interface Board (A18) to BERT (A6)
W3	8120-5063	1	DATA to Motherboard (A14P5)
W4	8120-5063	1	DATA CLOCK to Motherboard (A14P6)
W5	8120-5063	1	SYMBOL SYNC to Motherboard (A14P7)
W15	8120-5055	1	Baseband Generator (A7P403) to BASEBAND GENREF IN
W16	8120-5055	1	Baseband Generator (A7P404) to Rear Panel (Q OUT)
W17	8120-5055	1	Baseband Generator (A7P405) to Rear Panel (I OUT)
W18	8120-8457	1	Rear Panel Interface Board (A17) to Data Generator (A8P2) and Baseband Generator (A7P2) (Option UN8 - connects in three places)
W19	8120-8349	1	Baseband Generator (A7P300) to Data Generator (A8P3) (Option UN8)
W21	8120-5055	1	Bit Error Rate Test Board (A6) to BER GATE IN (Options UN7, UN8)
W22	8120-5055	1	Bit Error Rate Test Board (A6) to BER CLK IN (Options UN7, UN8)
W23	8120-5055	1	Bit Error Rate Test Board (A6) to BER DATA IN (Options UN7, UN8)
W27	8120-8725	1	16-Pin Ribbon Cable, Parallel Data In, Data Generator (A8) to Baseband Generator (A7)

1. This cable is not replaceable by itself. You must order the corresponding assembly.

Figure 3-8 Top View (ESG-D Series - Options UN7, UN8)

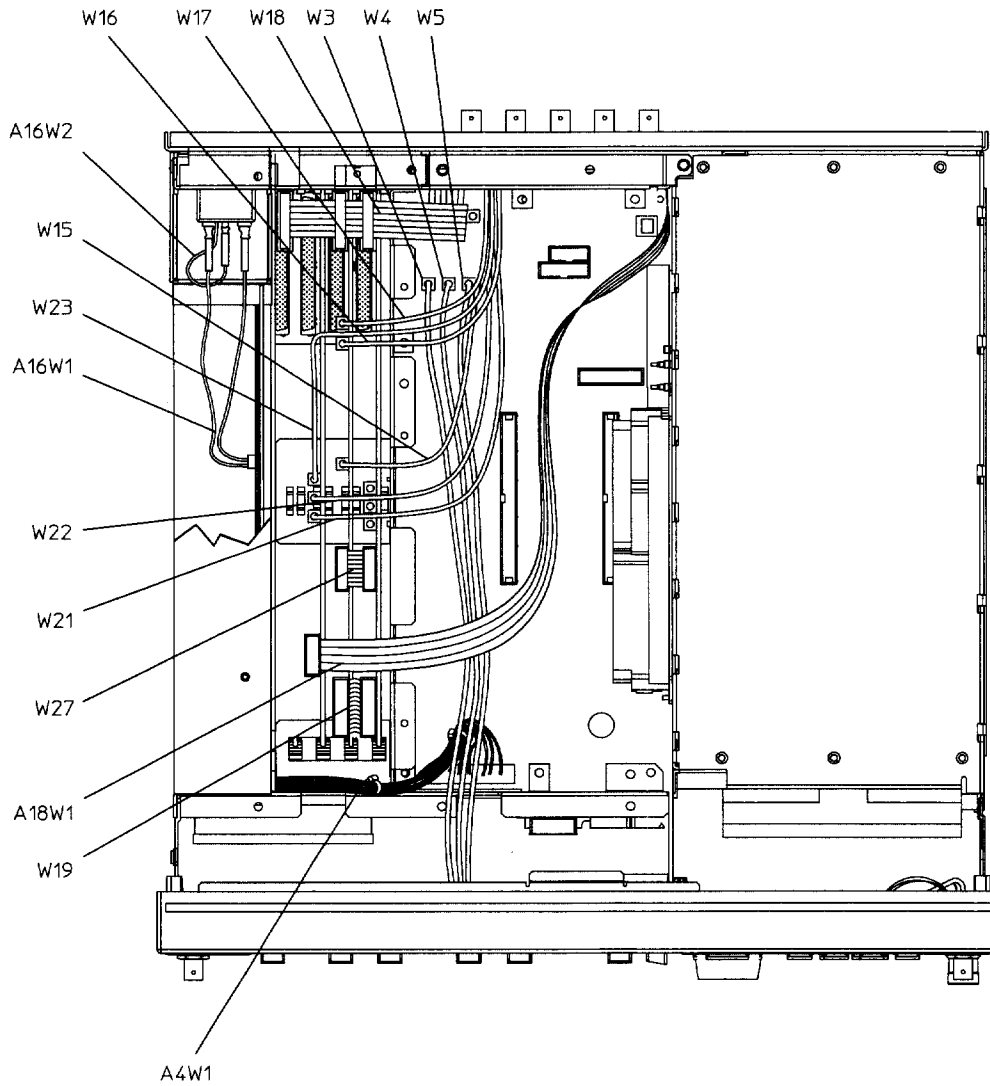

sk762b

Top View (ESG-D Series - Option UND)

Refer to Table 3-9 and Figure 3-9.

Table 3-9 Top View (ESG-D Series - Option UND)

Reference Designator	Part Number	Qty	Description
A4W1 ¹	(part of A4)	1	Power Supply (A4) to CPU/Motherboard (A14J6)
A16W1 ¹	(part of A16)	1	Line Module (A16) to Power Supply (A4J1)
A16W2 ¹	(part of A16)	1	Line Module (A16) to Chassis Ground Post on Rear Panel
W15	8120-5055	1	Dual Arb Waveform Generator (A5) to BASEBAND GEN REF
W16	8120-5055	1	Dual Arb Waveform Generator (A5) to Q OUT
W17	8120-5055	1	Dual Arb Waveform Generator (A5) to I OUT
W18	8120-8458	1	Rear Panel Interface Board (A17) to Dual Arb Waveform Generator (A5)
W18	8120-8457	1	Rear Panel Interface Board (A17) to Data Generator (A8P2), Baseband Generator (A7P2), and Dual Arb Waveform Generator (A5) (Option UN8 - connects in three places)
W24	E4400-20131	1	Baseband Generator - 13 MHz (A7) to Dual Arb Waveform Generator - 13 MHz (A5) (Option UN3 or UN4)

1. This cable is not replaceable by itself. You must order the corresponding assembly.

Figure 3-9 Top View (ESG-D Series - Option UND)

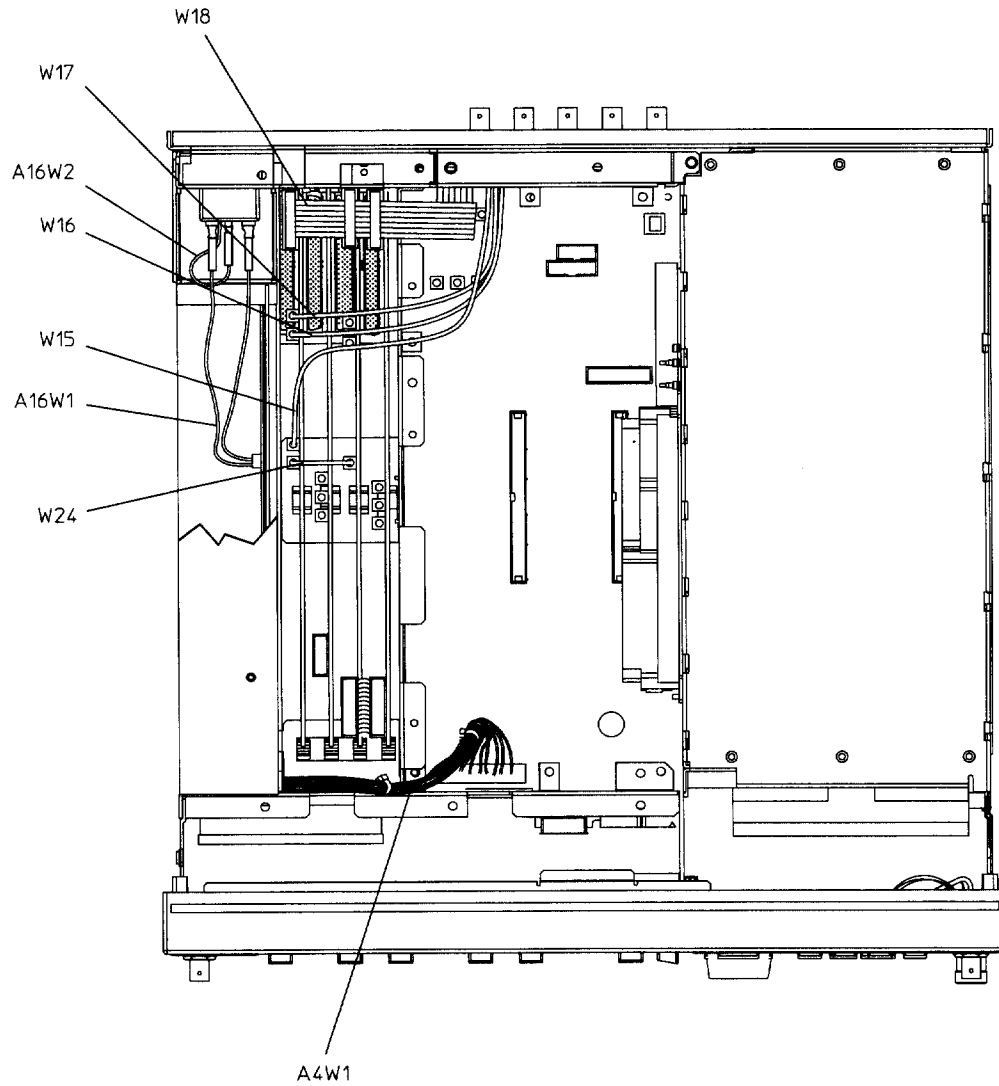

sk79b

Top View (ESG-D Series - Options UN3/4, UN7 with 1EM)

Refer to Table 3-10 and Figure 3-10.

Table 3-10 Top View (ESG-D Series - Options UN3/4, UN7 with 1EM)

Reference Designator	Part Number	Qty	Description
A4W1 ¹	(part of A4)	1	Power Supply (A4) to CPU/Motherboard (A14J6)
A16W1 ¹	(part of A16)	1	Line Module (A16) to Power Supply (A4J1)
A16W2 ¹	(part of A16)	1	Line Module (A16) to Chassis Ground Post on Rear Panel
A18W1 ¹	(part of A18)	1	BERT Rear Panel Interface Board (A18) to BERT (A6) (Option UN7)
W3	8120-5556	1	DATA to Data Generator (A8J2) (Options UN3/4)
W4	8120-5556	1	DATA CLOCK to Data Generator (A8J1) (Options UN3/4)
W5	8120-5556	1	SYMBOL SYNC to Data Generator (A8J3) (Options UN3/4)
W15	8120-5055	1	Baseband Generator (A7P403) to BASEBAND GENREF IN (Options UN3/4)
W16	8120-5055	1	Baseband Generator (A7P404) to Q OUT (Options UN3/4)
W17	8120-5055	1	Baseband Generator (A7P405) to I OUT (Options UN3/4)
W18	8120-8458	1	Rear Panel Interface Board (A17) to Data Generator (A8P2) (Options UN3/4)
W19	8120-8349	1	Baseband Generator (A7P300) to Data Generator (A8P3) (Options UN3/4)
W21	8120-5556	1	Bit Error Rate Test Board (A6) to BER GATE IN (Option UN7)
W22	8120-5556	1	Bit Error Rate Test Board (A6) to BER CLK IN (Option UN7)
W23	8120-5556	1	Bit Error Rate Test Board (A6) to BER DATA IN (Option UN7)

1. This cable is not replaceable by itself. You must order the corresponding assembly.

Figure 3-10 Top View (ESG-D Series - Options UN3/4, UN7 with 1EM)

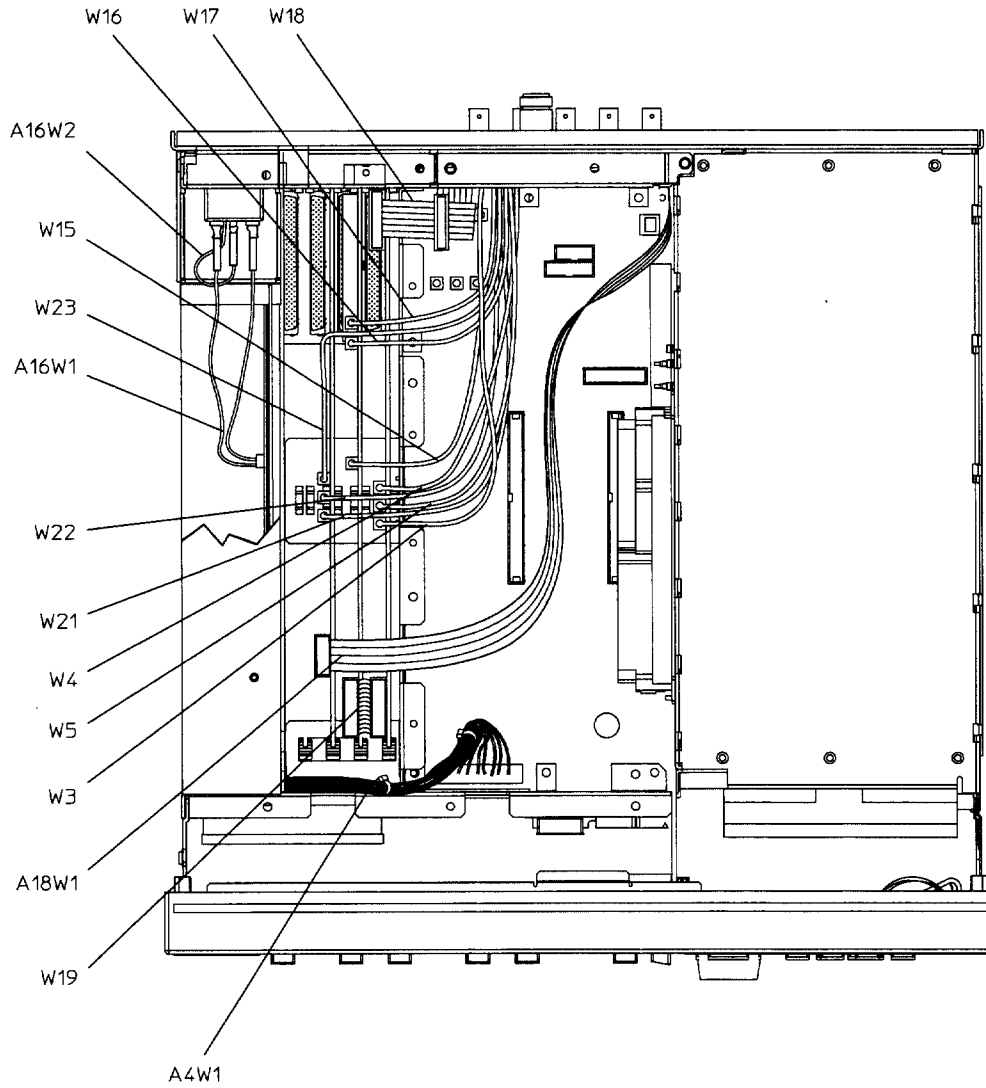

sk710b

Top View (ESG-D Series - Options UN7, UN8 with 1EM)

Refer to Table 3-11 and Figure 3-11.

Table 3-11 Top View (ESG-D Series - Options UN7, UN8 with 1EM)

Reference Designator	Part Number	Qty	Description
A4W1 ¹	(part of A4)	1	Power Supply (A4) to CPU/Motherboard (A14J6)
A16W1 ¹	(part of A16)	1	Line Module (A16) to Power Supply (A4J1)
A16W2 ¹	(part of A16)	1	Line Module (A16) to Chassis Ground Post on Rear Panel
A18W1 ¹	(part of A18)	1	BERT Rear Panel Interface Board (A18) to BERT (A6) (Option UN7)
W3	8120-5556	1	DATA to Data Generator (A8J2) (Option UN8)
W4	8120-5556	1	DATA CLOCK to Data Generator (A8J1) (Option UN8)
W5	8120-5556	1	SYMBOL SYNC to Data Generator (A8J3) (Option UN8)
W15	8120-5055	1	Baseband Generator (A7P403) to BASEBAND GENREF IN (Option UN8)
W16	8120-5055	1	Baseband Generator (A7P404) to Q OUT (Option UN8)
W17	8120-5055	1	Baseband Generator (A7P405) to I OUT (Option UN8)
W18	8120-8457	1	Rear Panel Interface Board (A17) to Data Generator (A8P2) and Baseband Generator (A7P2) (Option UN8 - connects in three places)
W19	8120-8349	1	Baseband Generator (A7P300) to Data Generator (A8P3) (Option UN8)
W21	8120-5556	1	Bit Error Rate Test Board (A6) to BER GATE IN (Option UN7)
W22	8120-5556	1	Bit Error Rate Test Board (A6) to BER CLK IN (Option UN7)
W23	8120-5556	1	Bit Error Rate Test Board (A6) to BER DATA IN (Option UN7)
W27	8120-8725	1	16-Pin Ribbon Cable, Parallel Data In, Data Generator (A8) to Baseband Generator (A7)

1. This cable is not replaceable by itself. You must order the corresponding assembly.

Figure 3-11 Top View (ESG-D Series - Options UN7, UN8 with 1EM)

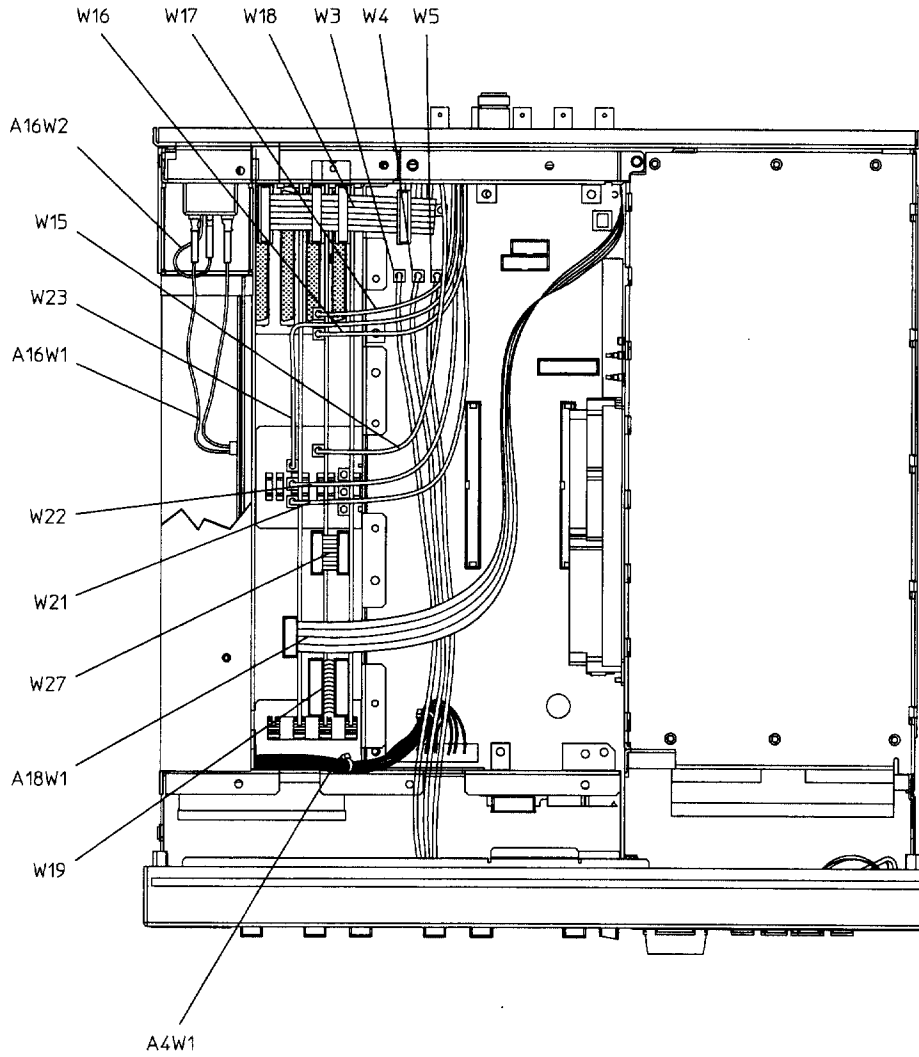

sk7116b

Top View (ESG-D Series - Options UN7, UN8, UND)

Refer to Table 3-12 and Figure 3-12.

Table 3-12 Top View (ESG-D Series - Options UN7, UN8, UND)

Reference Designator	Part Number	Qty	Description
A4W1 ¹	(part of A4)	1	Power Supply (A4) to CPU/Motherboard (A14J6)
A16W1 ¹	(part of A16)	1	Line Module (A16) to Power Supply (A4J1)
A16W2 ¹	(part of A16)	1	Line Module (A16) to Chassis Ground Post on Rear Panel
A18W1 ¹	(part of A18)	1	BERT Rear Panel Interface Board (A18) to BERT (A6) (Option UN7)
W3	8120-5556	1	DATA to Data Generator (A8J2) (Option UN8)
W4	8120-5556	1	DATA CLOCK to Data Generator (A8J1) (Option UN8)
W5	8120-5556	1	SYMBOL SYNC to Data Generator (A8J3) (Option UN8)
W15	8120-5055	1	Baseband Generator (A7P403) to BASEBAND GENREF IN (Option UN8)
W16	8120-5055	1	Baseband Generator (A7P404) to Q OUT (Option UN8)
W17	8120-5055	1	Baseband Generator (A7P405) to I OUT (Option UN8)
W18	8120-8457	1	Rear Panel Interface Board (A17) to Data Generator (A8P2) and Baseband Generator (A7P2) (Option UN8 - connects in three places)
W19	8120-8349	1	Baseband Generator (A7P300) to Data Generator (A8P3) (Option UN8)
W21	8120-5556	1	Bit Error Rate Test Board (A6) to BER GATE IN (Option UN7)
W22	8120-5556	1	Bit Error Rate Test Board (A6) to BER CLK IN (Option UN7)
W23	8120-5556	1	Bit Error Rate Test Board (A6) to BER DATA IN (Option UN7)
W24	E4400-20131	1	Baseband Generator-13 MHz (A7) to Dual Arb Waveform Generator - 13 MHz (A5) (Option UN3 or UN4)
W25	8120-8748	1	Motherboard (A14P103) to Daughterboard - Q INT (A15J8)
W26	8120-8748	1	Motherboard (A14P102) to Daughterboard - I INT (A15J9)
W27	8120-8725	1	16-Pin Ribbon Cable, Parallel Data In, Data Generator (A8) to Baseband Generator (A7)

1. This cable is not replaceable by itself. You must order the corresponding assembly.

Figure 3-12 Top View (ESG-D Series - Options UN7, UN8, UND)

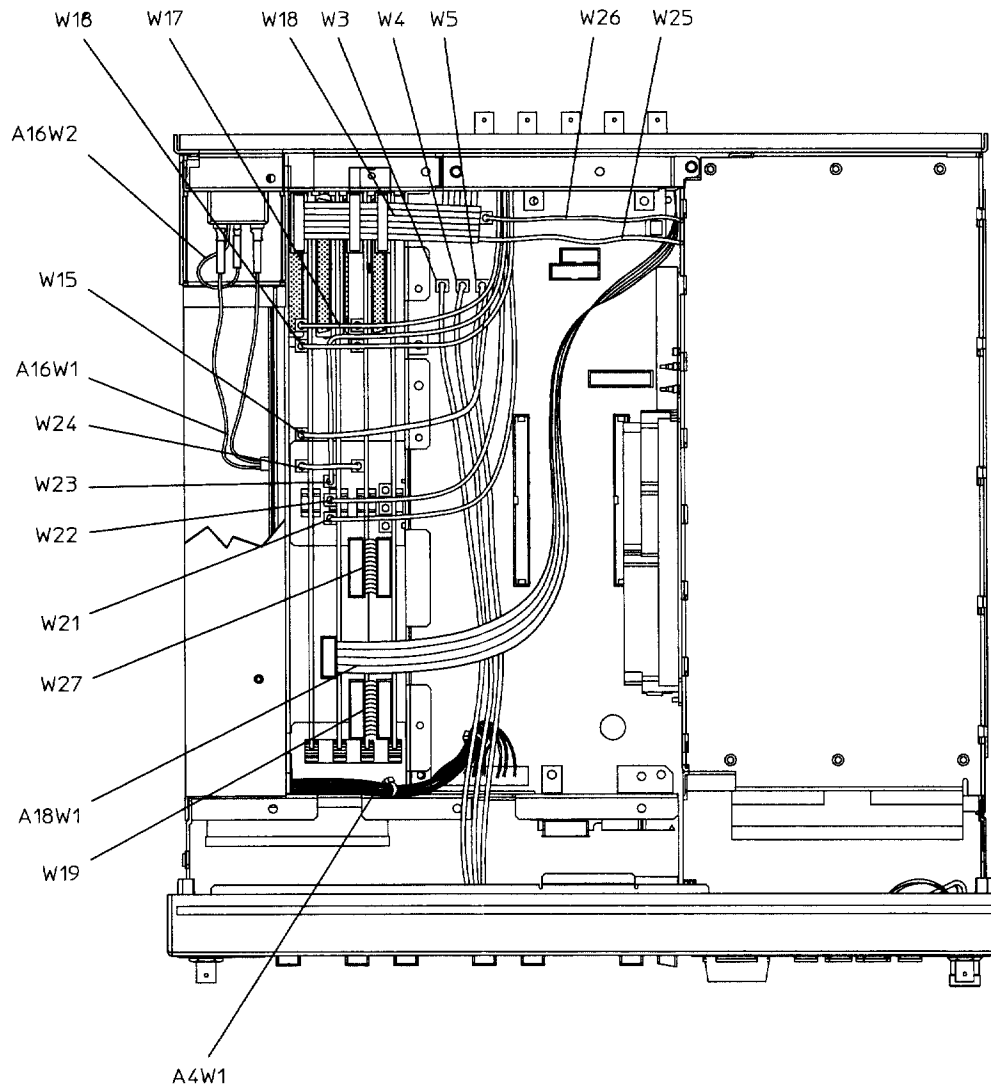

sk7160b

Top View (ESG-D Series - Option UND with 1EM)

Refer to Table 3-13 and Figure 3-13.

Table 3-13 Top View (ESG-D Series - Option UND with 1EM)

Reference Designator	Part Number	Qty	Description
A4W1 ¹	(part of A4)	1	Power Supply (A4) to CPU/Motherboard (A14J6)
A16W1 ¹	(part of A16)	1	Line Module (A16) to Power Supply (A4J1)
A16W2 ¹	(part of A16)	1	Line Module (A16) to Chassis Ground Post on Rear Panel
W15	8120-5055	1	Dual Arb Waveform Generator (A5) to BASEBAND GENREF IN
W16	8120-5055	1	Dual Arb Waveform Generator (A5) to Q OUT
W17	8120-5055	1	Dual Arb Waveform Generator (A5) to I OUT
W18	8120-8458	1	Rear Panel Interface Board (A7) to Dual Arb Waveform Generator (A5)
W18	8120-8457	1	Rear Panel Interface Board (A17) to Data Generator (A8P2), Baseband Generator (A7P2), and Dual Arb Waveform Generator (A5) (Option UN8 - connects in four places)
W24	E4400-20131	1	Baseband Generator - 13 MHz (A7) to Dual Arb Waveform Generator - 13 MHz (A5) (Option UN3 or UN4)

1. This cable is not replaceable by itself. You must order the corresponding assembly.

Figure 3-13 Top View (ESG-D Series - Option UND with 1EM)

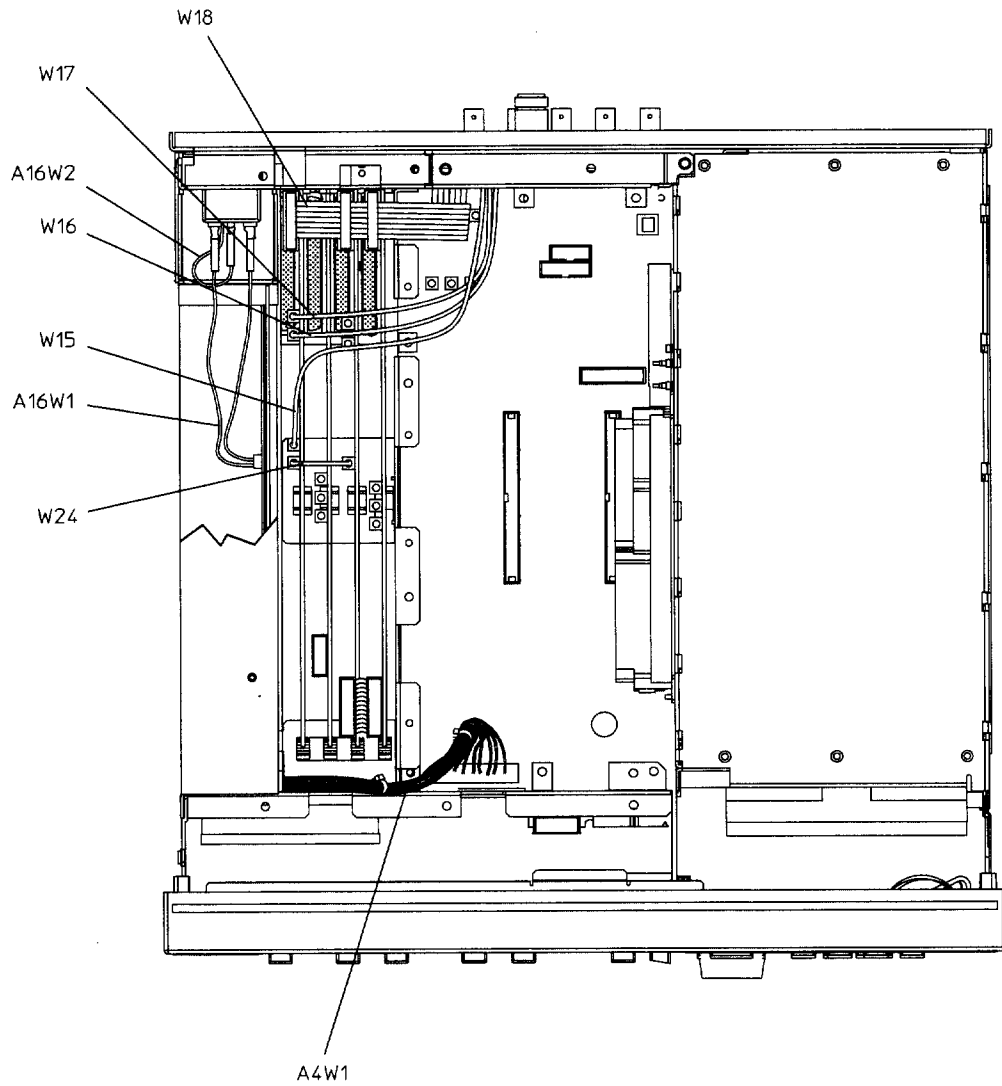

sk711b

Top View (ESG-D Series - Option 300)

Refer to Table 3-14 and Figure 3-14.

Table 3-14 Top View (ESG-D Series - Option 300)

Reference Designator	Part Number	Qty	Description
W18	8121-0042	1	16-Pin Ribbon Cable, Rear Panel I/O, Rear Panel Interface Board (A17) to Data Generator (A8), Baseband Generator (A7), and Demodulator (A21) (connects in four places)
W19	8121-0040	1	24-Pin Ribbon Cable, BBG I/O, Data Generator (A8) to Demodulator (A21)
W21	8120-5055	1	Flexible Cable, BER GATE IN (RP) to Demodulator (A21)
W22	8120-5055	1	Flexible Cable, BER CLK IN (RP) to Demodulator (A21)
W23	8120-5055	1	Flexible Cable, BER DATA IN (RP) to Demodulator (A21)
W27	8120-8725	1	16-Pin Ribbon Cable, Parallel Data In, Data Generator (A8) to Baseband Generator (A7)
W28	8120-5206	1	Flexible Cable, BERT (A6, BER Gate In) to Demodulator (A21)
W29	8121-0045	1	Flexible Cable, BERT (A6, BER Clk In) to Demodulator (A21)
W30	8120-5014	1	Flexible Cable, BERT (A6, BER Data In) to Demodulator (A21)
W31	8120-8789	1	Ribbon Cable, Motherboard (A14J26) to A20 Down Convertor
W32	8121-0044	1	Flexible Cable, 321.4 MHZ IN (RP) to A20 Down Convertor
W33	8121-0043	1	Flexible Cable, Down Convertor (A20, 26 MHz) to Demodulator (A21, Freq Ref 26 MHz)
W34	8121-0043	1	Flexible Cable, Down Convertor (A20, IF In) to Demodulator (A21, IF In)
A18W1	(part of A18)	1	10-Pin Ribbon Cable, BER Status, BERT Rear Panel Interface (A18) to Data Generator (A8), Baseband Generator (A7), and BERT (A6)

Figure 3-14 Top View (ESG-D Series - Option 300)

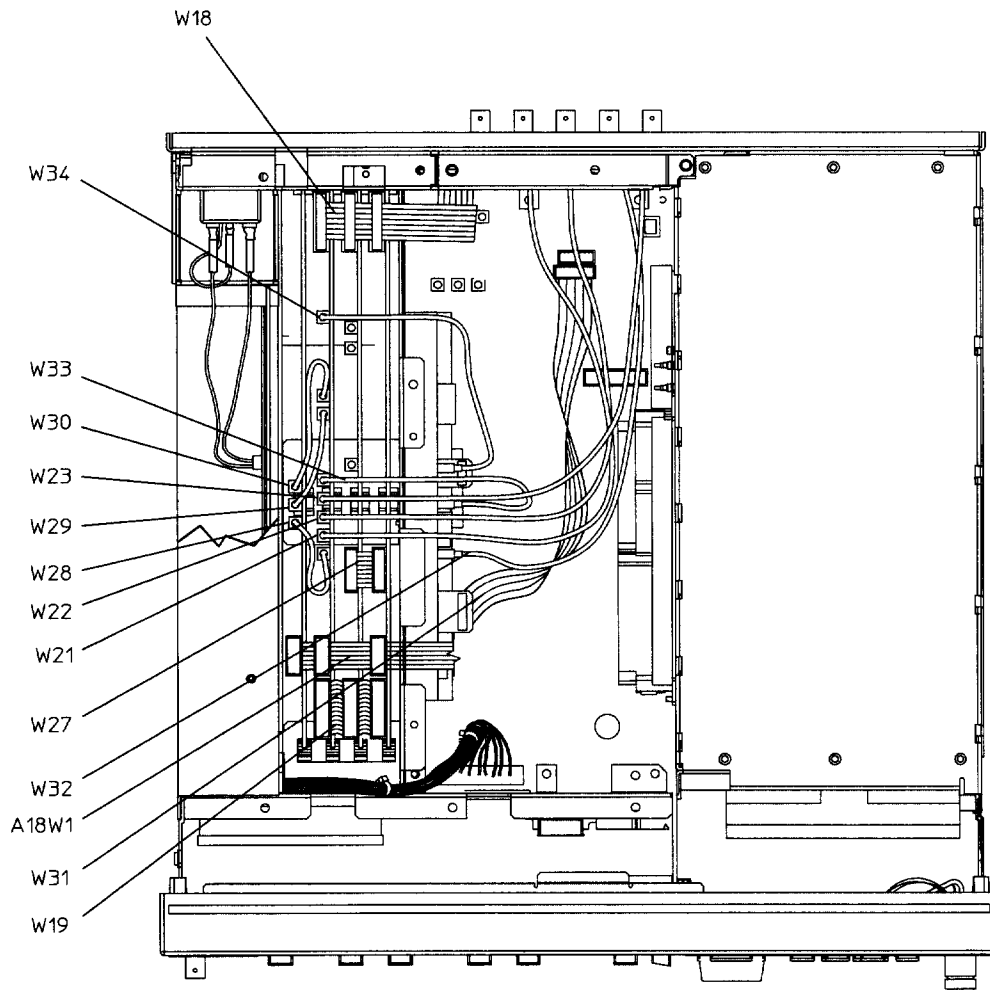

sk797b

Inside Front Panel View

Refer to Table 3-15 and Figure 3-15.

Table 3-15 Inside Front Panel View

Reference Designator	Part Number	Qty	Description
A1W1 ¹	(part of A1)	1	Front Panel Board (A1) to CPU/Motherboard (A14J20)
A2DS1W1 ¹	(part of A2DS1)	1	Florescent Lamp (A2DS1) to A3W2
A3W1 ¹	(part of A3)	1	Inverter (A3) to CPU/Motherboard (A14J19)
A3W2 ¹	(part of A3)	1	Inverter (A3) to A2DS1W1
B1W1 ¹	(part of B1)	1	Small Fan (B1) to CPU/Motherboard (A14J16)
B2W1 ¹	(part of B2)	1	Large Fan (B2) to CPU/Motherboard (A14J17)
W1	8120-6758	1	I IN to Daughterboard (A15J2)
W2	8120-6758	1	Q IN to Daughterboard (A15J3)
W3	8120-5063	1	DATA to Baseband Generator (A7P100) (Options UN3/4)
W4	8120-5063	1	DATA CLOCK to Baseband Generator (A7P103) (Options UN3/4)
W5	8120-5063	1	SYMBOL SYNC to Baseband Generator (A7P101) (Options UN3/4)
W6	8120-6758	1	EXT 1 to Daughterboard (A15J4)
W7	8120-6758	1	EXT 2 to Daughterboard (A15J5)
W8	8120-6758	1	LF OUTPUT to Daughterboard (A15J6)
W9	E4400-20018	1	RF OUTPUT to Electronic Attenuator/RPP (AT1)
W9	E4400-20125	1	RF OUTPUT to RPP (AT1) (Option 1EM, UNB)
W10	8120-6759	1	Display (A2) to CPU/Motherboard (A14J21)
W47	8120-8783	1	Flexible Cable, PULSE IN (FP) to Pulse Modulator (A25) (not shown)

1. This cable is not replaceable by itself. You must order the corresponding assembly.

NOTE Figure 3-15 shows an ESG-D series front panel having options UN3/4 or UN8. On a standard ESG-D series front panel, W3, W4, and W5 do not exist and the front panel connectors for W1 and W2 will be in a slightly different location. An ESG-A series front panel does not include W1 through W5, but will include W47 with Option 1E6 (not shown). All models having Option 1EM do not have W1 through W9 on the front panel.

Figure 3-15 Inside Front Panel View

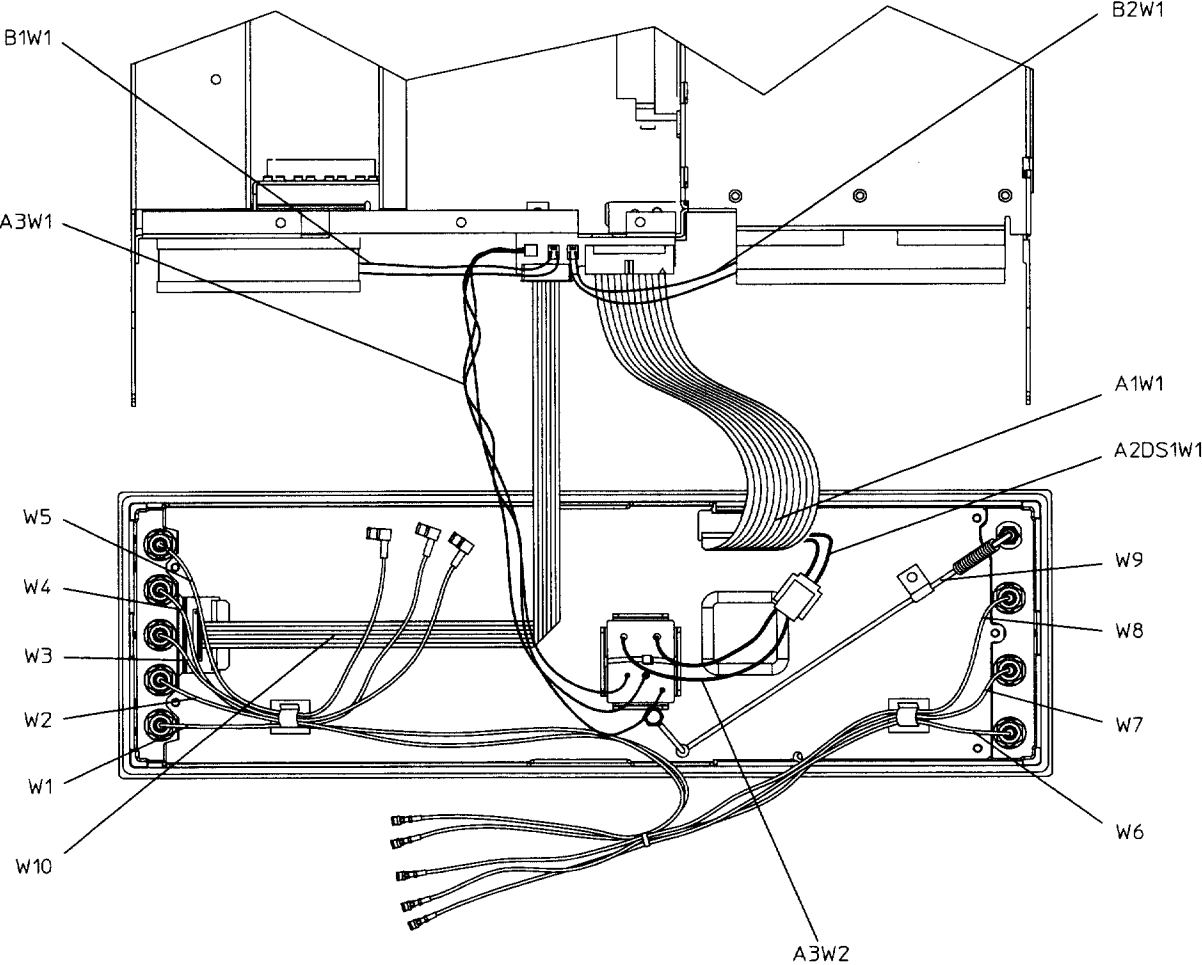

sk7146b

Electronic Attenuator/RPP View

Refer to Table 3-16 and Figure 3-16.

Table 3-16 Electronic Attenuator/RPP View

Reference Designator	Part Number	Qty	Description
W1	8120-6758	1	I IN to Daughterboard (A15J2)
W2	8120-6758	1	Q IN to Daughterboard (A15J3)
W6	8120-6758	1	EXT 1 to Daughterboard (A15J4)
W7	8120-6758	1	EXT 2 to Daughterboard (A15J5)
W8	8120-6758	1	LF OUTPUT to Daughterboard (A15J6)
W9	E4400-20018	1	RF OUTPUT to Electronic Attenuator/RPP (AT1)
W11	E4400-60059	1	Output Board (A9) to Synthesizer/Doubler Board (A12) (includes cable retainer and ring)
W12	E4400-60060	1	Output Board (A9) to COHERENT CARRIER (includes cable retainer and ring)
W13	8120-6837	1	Electronic Attenuator/RPP (AT1) to CPU/Motherboard (A14J14)
W14	E4400-60061	1	Electronic Attenuator/RPP (AT1) to Output Board (A9) (includes cable retainer and ring)
W25	8120-8748	1	Motherboard (A14P103) to Daughterboard - Q INT (A15J8)
W26	8120-8748	1	Motherboard (A14P102) to Daughterboard - I INT (A15J9)

Figure 3-16 Electronic Attenuator/RPP View

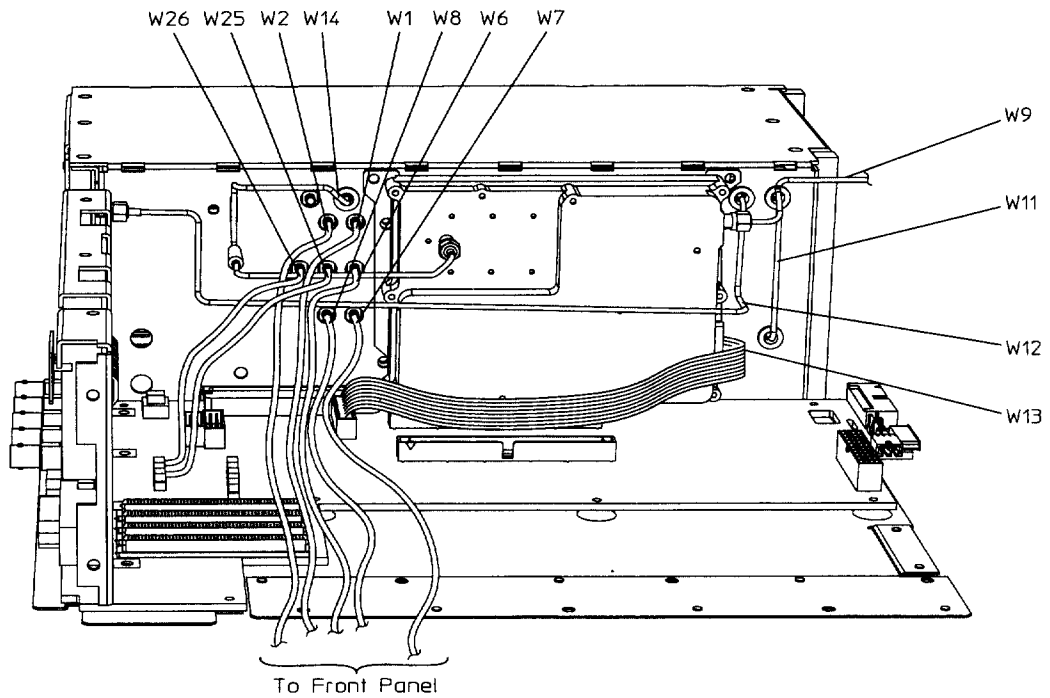

sk712b

Cables

Electronic Attenuator/RPP View (with Option 1EM)

Refer to Table 3-17 and Figure 3-17.

Table 3-17 Electronic Attenuator/RPP View (with Option 1EM)

Reference Designator	Part Number	Qty	Description
W1	8120-6839	1	I IN to Daughterboard (A15J2)
W2	8120-6839	1	Q IN to Daughterboard (A15J3)
W6	8120-6839	1	EXT 1 to Daughterboard (A15J4)
W7	8120-6839	1	EXT 2 to Daughterboard (A15J5)
W8	8120-6839	1	LF OUTPUT to Daughterboard (A15J6)
W9	E4400-20025	1	RF OUTPUT to Electronic Attenuator/RPP (AT1)
W11	E4400-60059	1	Output Board (A9) to Synthesizer/Doubler Board (A12) (includes cable retainer and ring)
W12	E4400-60060	1	Output Board (A9) to COHERENT CARRIER (includes cable retainer and ring)
W13	8120-6837	1	Electronic Attenuator/RPP (AT1) to CPU/Motherboard (A14J14)
W14	E4400-60061	1	Electronic Attenuator/RPP (AT1) to Output Board (A9) (includes cable retainer and ring)
W25	8120-8748	1	Motherboard (A14P103) to Daughterboard - Q INT (A15J8)
W26	8120-8748	1	Motherboard (A14P102) to Daughterboard - I INT (A15J9)

Figure 3-17 Electronic Attenuator/RPP View (with Option 1EM)

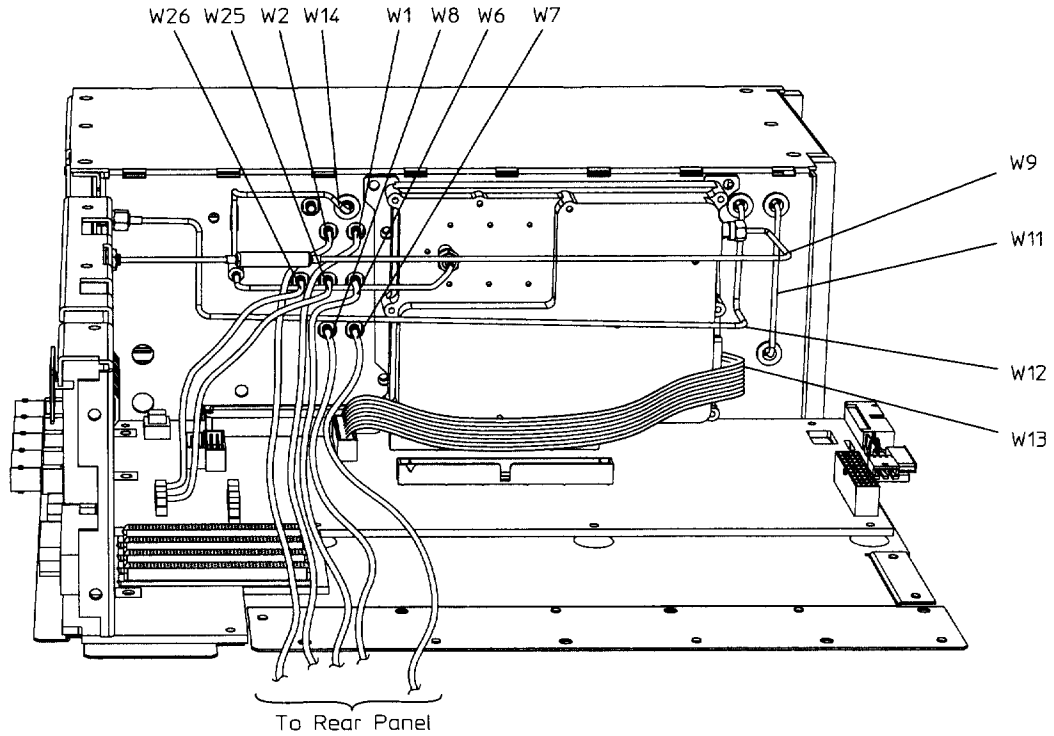

sk713b

Mechanical Attenuator View (Option UNB)

Refer to Table 3-18 and Figure 3-18.

Table 3-18 Mechanical Attenuator View (Option UNB)

Reference Designator	Part Number	Qty	Description
A19W1 ¹	(part of A19)	1	RPP (A19) to Motherboard (A14J15)
W1	8120-6839	1	I IN to Daughterboard (A15J2)
W2	8120-6839	1	Q IN to Daughterboard (A15J3)
W6	8120-6758	1	EXT 1 to Daughterboard (A15J4)
W7	8120-6758	1	EXT 2 to Daughterboard (A15J5)
W8	8120-6758	1	LF OUTPUT to Daughterboard (A15J6)
W9	E4400-20125	1	RF OUTPUT to RPP (A19)
W11	E4400-60059	1	Output Board (A9) to Synthesizer/Doubler Board (A12) (includes cable retainer and ring)
W12	E4400-60176	1	Output Board (A9) to COHERENT CARRIER (includes cable retainer and ring)
W13	E4400-20132	1	Mechanical Attenuator (AT1) to CPU/Motherboard (A14J14)
W14	E4400-60177	1	Mechanical Attenuator (AT1) to Output Board (A9) (includes cable retainer and ring)
W20	E4400-20126	1	Mechanical Attenuator (AT1) to RPP (A19)
W25	8120-8748	1	Motherboard (A14P103) to Daughterboard - Q INT (A15J8)
W26	8120-8748	1	Motherboard (A14P102) to Daughterboard - I INT (A15J9)

1. This cable is not replaceable by itself. You must order the corresponding assembly.

Figure 3-18 Mechanical Attenuator View (Option UNB)

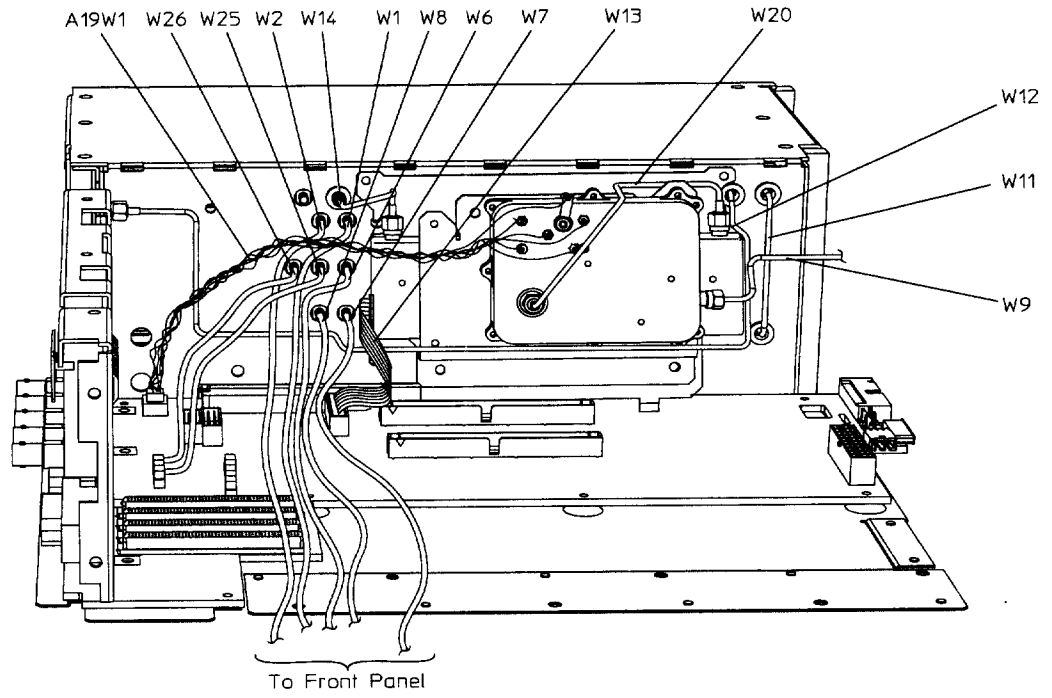

sk715b

Mechanical Attenuator View (Option UNB with 1EM)

Refer to Table 3-19 and Figure 3-19.

Table 3-19 Mechanical Attenuator View (Option UNB with 1EM)

Reference Designator	Part Number	Qty	Description
A19W1 ¹	(part of A19)	1	RPP (A19) to Motherboard (A14J15)
W1	8120-6839	1	I IN to Daughterboard (A15J2)
W2	8120-6839	1	Q IN to Daughterboard (A15J3)
W6	8120-6839	1	EXT 1 to Daughterboard (A15J4)
W7	8120-6839	1	EXT 2 to Daughterboard (A15J5)
W8	8120-6839	1	LF OUTPUT to Daughterboard (A15J6)
W9	E4400-20143	1	RF OUTPUT to RPP (A19)
W11	E4400-60059	1	Output Board (A9) to Synthesizer/Doubler Board (A12) (includes cable retainer and ring)
W12	E4400-60176	1	Output Board (A9) to COHERENT CARRIER (includes cable retainer and ring)
W13	E4400-20132	1	Mechanical Attenuator (AT1) to CPU/Motherboard (A14J14)
W14	E4400-60177	1	Mechanical Attenuator (AT1) to Output Board (A9) (includes cable retainer and ring)
W20	E4400-20126	1	Mechanical Attenuator (AT1) to RPP (A19)
W25	8120-8748	1	Motherboard (A14P103) to Daughterboard - Q INT (A15)
W26	8120-8748	1	Motherboard (A14P102) to Daughterboard - I INT (A15)

1. This cable is not replaceable by itself. You must order the corresponding assembly.

Figure 3-19 Mechanical Attenuator View (Option UNB with 1EM)

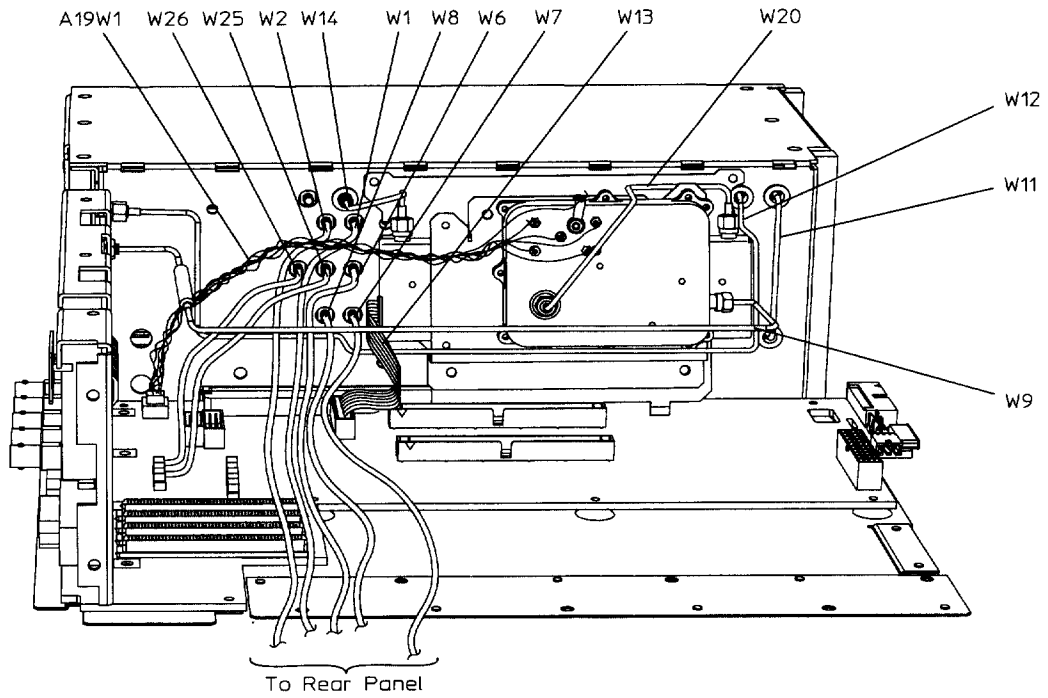

sk714b

Pulse Modulator View (Option 1E6)

Refer to Table 3-20 and Figure 3-20.

Table 3-20 Pulse Modulator View (Option 1E6)

Reference Designator	Part Number	Qty	Description
A25W1	(part of A25)	1	Wire Harness, Pulse Modulator (A25) to Motherboard (A14)
W45	E4423-20017	1	Semi-Rigid Cable, Output (A9) to Pulse Modulator (A25)
W45	E4423-20012	1	Semi-Rigid Cable, Output (A9) to Pulse Modulator (A25) (Option UNB - not shown)
W46	E4423-20014	1	Semi-Rigid Cable, Electronic Attenuator (AT1) to Pulse Modulator (A25)
W46	E4423-20011	1	Semi-Rigid Cable, Mechanical Attenuator (AT1) to Pulse Modulator (A25) (Option UNB - not shown)
W47	8120-8783	1	Cable, flexible pulse in (FP) to pulse modulator

Figure 3-20 Pulse Modulator View (Option 1E6)

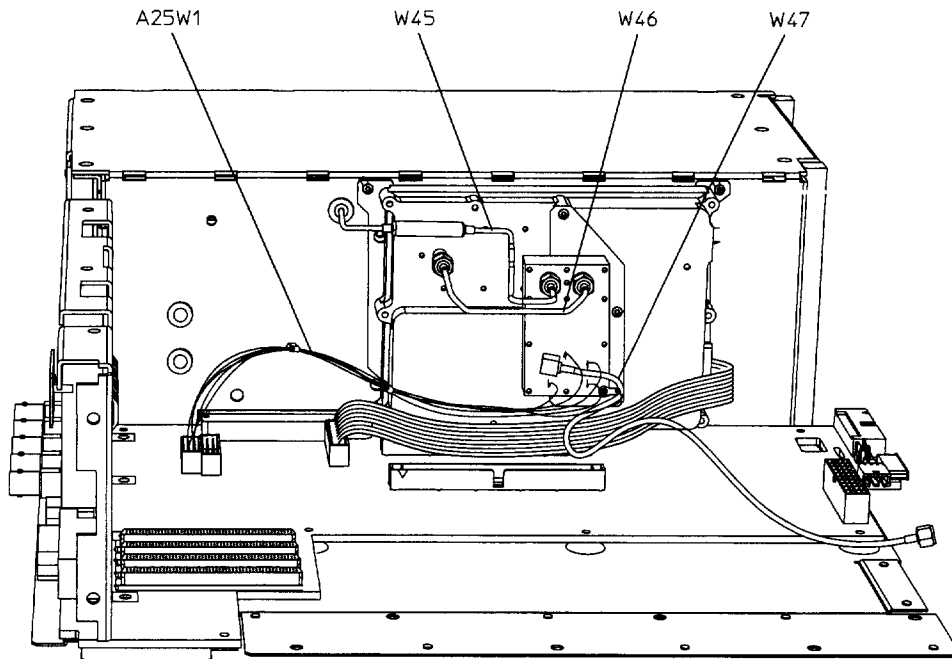

sk7139b

Hardware and Other Instrument Parts

This section lists part numbers for hardware and other parts in your signal generator. The following instrument views are provided to help you locate specific parts.

- “Top View” on page 3-46
- “Downconverter View (Option 300)” on page 3-48
- “Disassembled Mechanical Attenuator View (Option UNB)” on page 3-49
- “Disassembled Pulse Modulator View (Option 1E6)” on page 3-50
- “Disassembled Pulse Modulator View (Option 1E6/UNB)” on page 3-51
- “Front Panel View (ESG-A Series)” on page 3-52
- “Front Panel View (ESG-D Series)” on page 3-54
- “Disassembled Front-Panel View” on page 3-56
- “Daughterboard Card Cage View” on page 3-58
- “Inside Rear-Panel View” on page 3-59
- “Rear-Panel View (ESG-A Series)” on page 3-60
- “Rear-Panel View (ESG-A Series - Option 1EM)” on page 3-61
- “Rear-Panel View (ESG-D Series)” on page 3-62
- “Rear Panel View (ESG-D Series - Option 1EM)” on page 3-64
- “Instrument Chassis with Top and Right-Side Hardware” on page 3-66
- “Power Supply Shield and Left-Side Hardware” on page 3-68
- “Motherboard and Bottom-Side Hardware” on page 3-69
- “Instrument Cover and Associated Parts” on page 3-70

Top View

Refer to Table 3-21 and Figure 3-21.

Table 3-21 Top View

Item No.	Part Number	Qty	Description
1	1400-0054	1	Clamp-Semi-Rigid Cable (W14)
2	0515-0372	1	Screw-Machine M3x8 CW-PN-TX
3	0515-0430	2	Screw-Machine M3x6 CW-PN-TX
4	1400-1594	1	Clamp-Flexible Cables (not used on Option 1EM)
5	0361-1341	4	Rivet-Plastic
6	0515-0374	4	Screw-Machine M3x10 CW-PN-TX
7	E4400-20041	1	Shield Cap
8	0400-0001	1	Grommet Round .562ID
9	0515-1521	2	Screw-Machine M3x5 FL-TX
10	E4400-60221	1	A14Q501 Transistor Assembly
11	0515-0374	1	Screw-Machine M3x10 CW-PN-TX
12	0340-1162	1	Bushing, Insulator 0.119 ID
13	0340-0614	1	Insulator Pad, Transistor TO-220

Figure 3-21 Top View

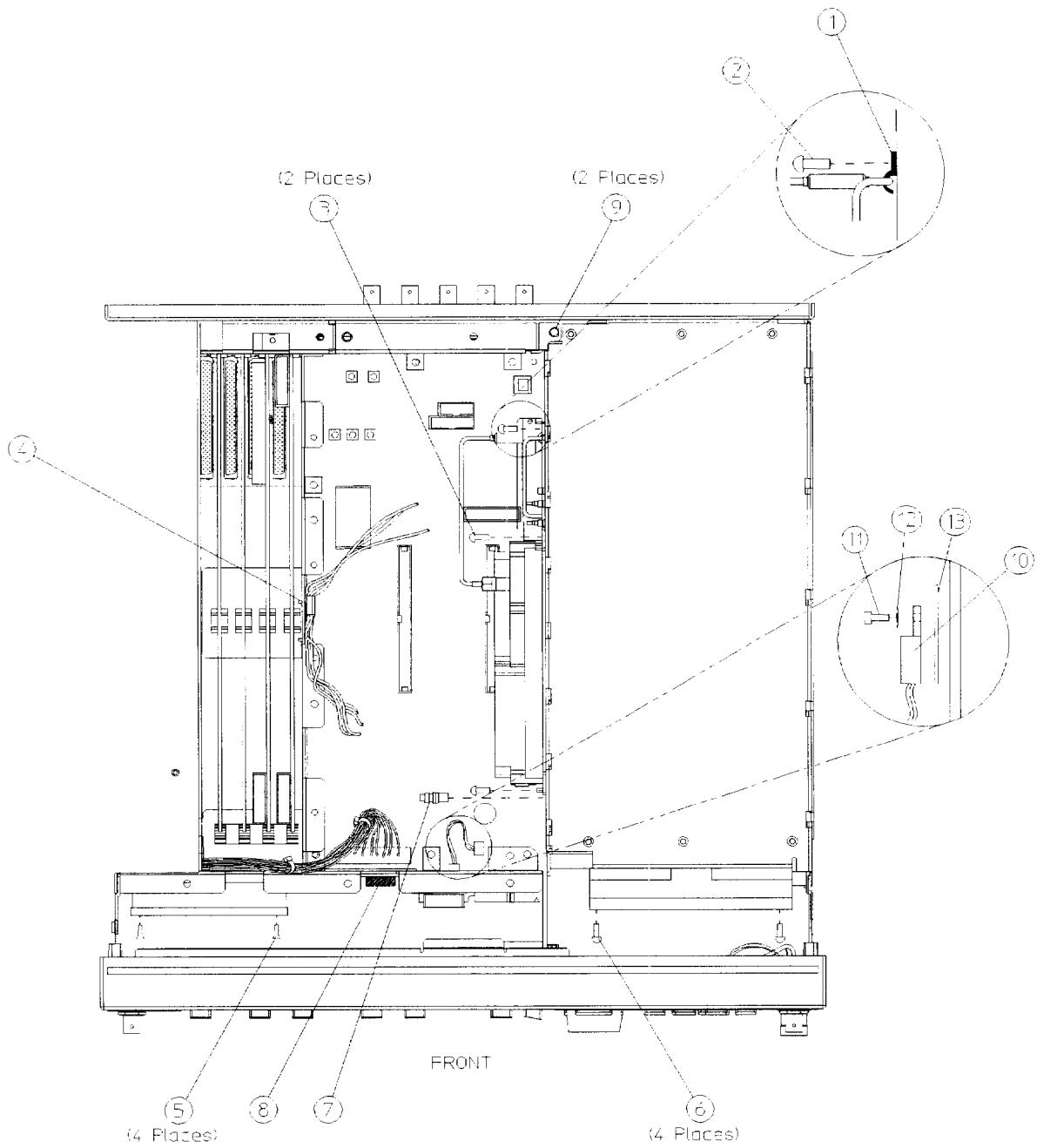

sk7105u

Downconverter View (Option 300)

Refer to Table 3-22 and Figure 3-22.

Table 3-22 Downconverter View

Item No.	Part Number	Qty	Description
1	0515-0372	2	Screw-Machine M3x8 CW-PN-TX

Figure 3-22 Downconverter View

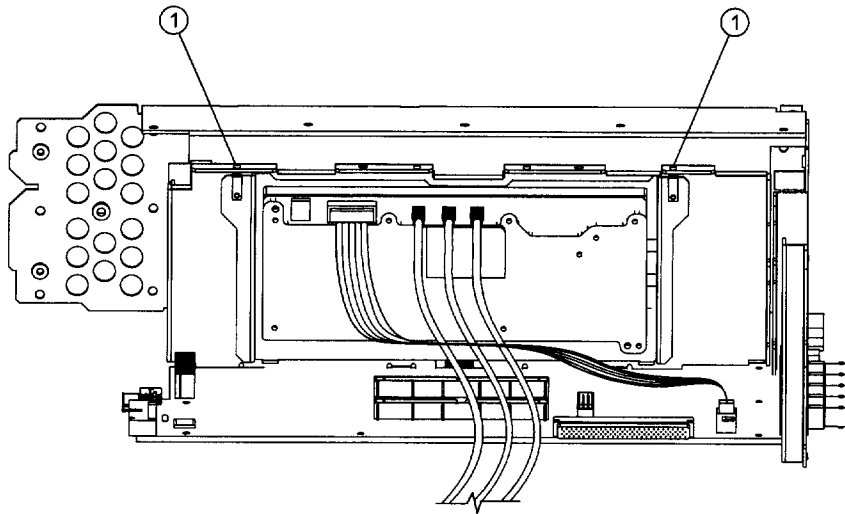

sk7150b

Disassembled Mechanical Attenuator View (Option UNB)

Refer to Table 3-23 and Figure 3-23.

Table 3-23 Disassembled Mechanical Attenuator View

Item No.	Part Number	Qty	Description
1	E4400-00027	1	Bracket-RPP
2	0515-0664	3	Screw-Machine M3x12 CW-PN-TX
3	0515-0430	2	Screw-Machine M3x6 CW-PN-TX
4	E4400-00028	1	Bracket-Attenuator
5	0515-1102	6	Screw-Machine M3x8 FL-TX

Figure 3-23 Disassembled Mechanical Attenuator View

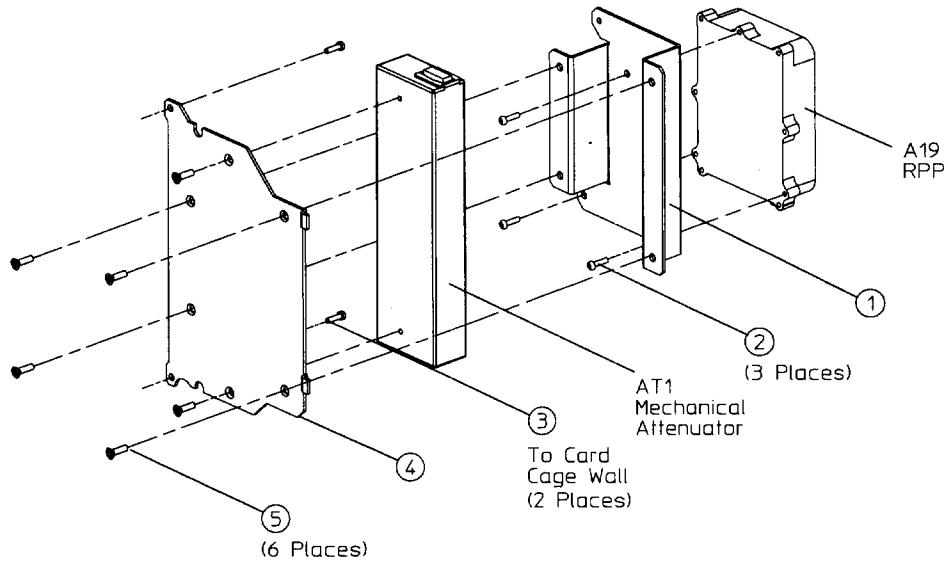

sk718b

Disassembled Pulse Modulator View (Option 1E6)

Refer to Table 3-24 and Figure 3-24.

Table 3-24 Disassembled Pulse Modulator View (Option 1E6)

Item No.	Part Number	Qty	Description
1	0515-0372	2	Screw-Machine M3x8 CW-PN-TX
2	E4423-00003	1	Bracket-Pulse Modulator
3	0515-2001	2	Screw-Machine M2.5x10 FL-TX

Figure 3-24 Disassembled Pulse Modulator View (Option 1E6)

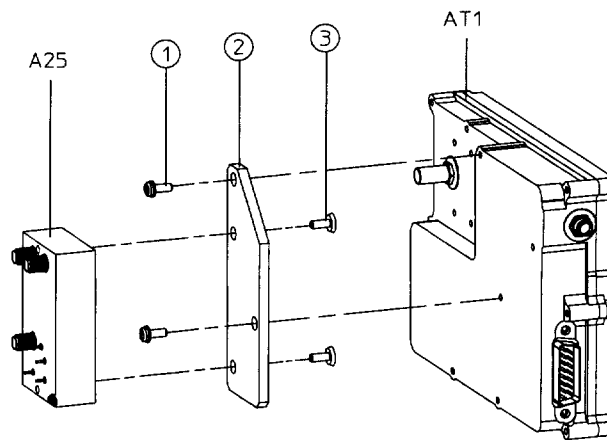

sk7152b

Disassembled Pulse Modulator View (Option 1E6/UNB)

Refer to Table 3-25 and Figure 3-25.

Table 3-25 Disassembled Pulse Modulator View (Option 1E6/UNB)

Item No.	Part Number	Qty	Description
1	E4400-00027	1	Bracket-RPP
2	0515-0664	3	Screw-Machine M3x12 CW-PN-TX
3	0515-0430	2	Screw-Machine M3x6 CW-PN-TX
4	E4400-00028	1	Bracket-Attenuator
5	0515-1102	6	Screw-Machine M3x8 FL-TX
6	0515-0367	2	Screw-Machine M2.5x8 CW-PN-TX

Figure 3-25 Disassembled Pulse Modulator View (Option 1E6/UNB)

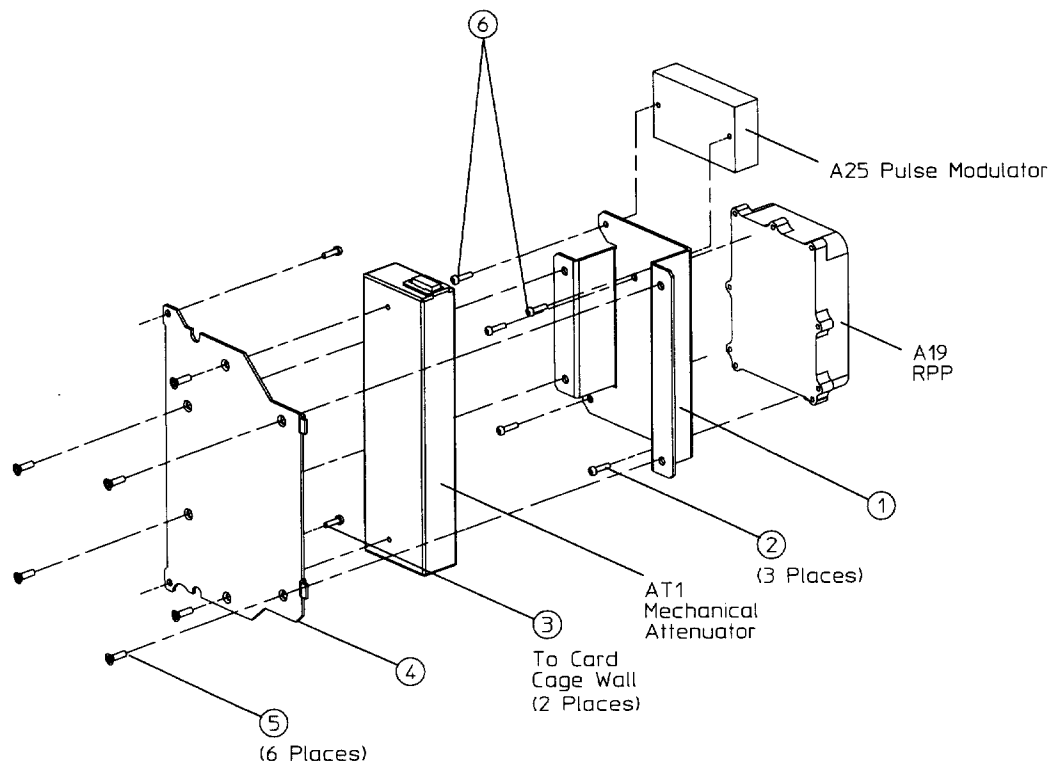

sk7149b

Front Panel View (ESG-A Series)

Refer to Table 3-26 and Figure 3-26.

Table 3-26 Front Panel View (ESG-A Series)

Item No.	Part Number	Qty	Description
1	E4400-80011	1	Label-Connectors
2	E4400-80072	1	Nameplate - E4400B 250k - 1GHz
2	E4400-80073	1	Nameplate - E4420B 250k - 2GHz
2	E4400-80074	1	Nameplate - E4421B 250k - 3GHz
2	E4400-80075	1	Nameplate - E4422B 250k - 4GHz
3	E4400-40003	1	Knob-RPG
4	E4400-80016	1	Label-Keypad
5	2950-0035	3	Nut-Hex 15/32-32
6	3050-1919	3	Washer-Wavy.490ID
7	E4400-80017	1	Label-Keypad (Option 1EM)
8	E4423-80001	1	Label-Connectors (Option 1E6)
9	2950-0035	4	Nut-Hex 15/32-32
10	3050-1919	4	Washer-Wavy .490ID

Figure 3-26 Front Panel View (ESG-A Series)

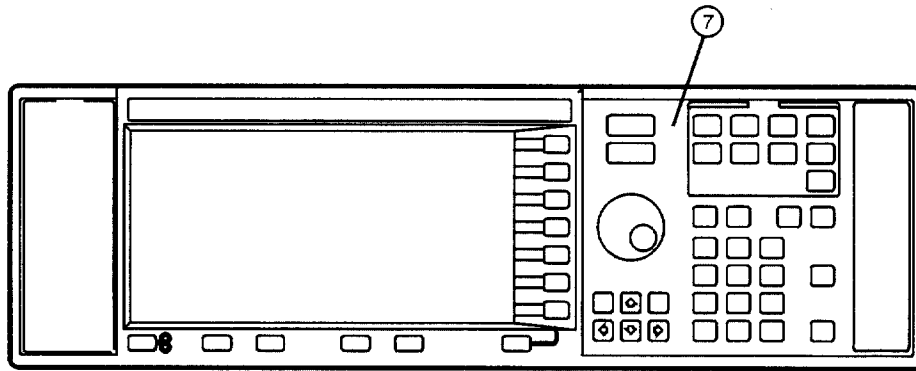
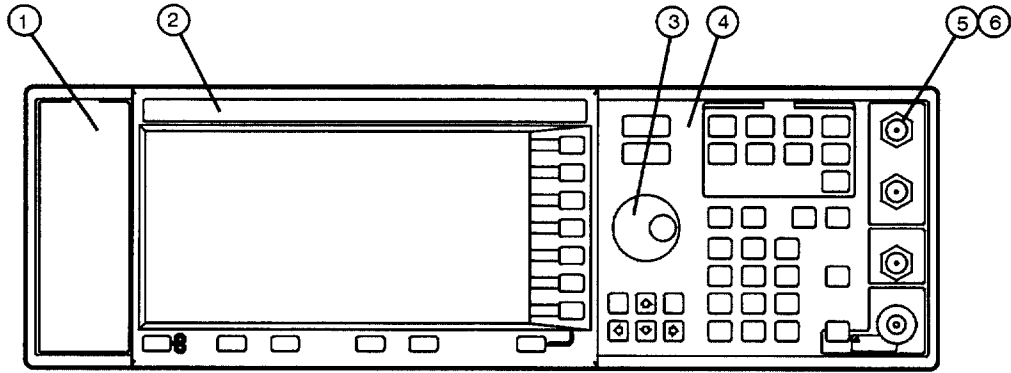

OPTION 1EM

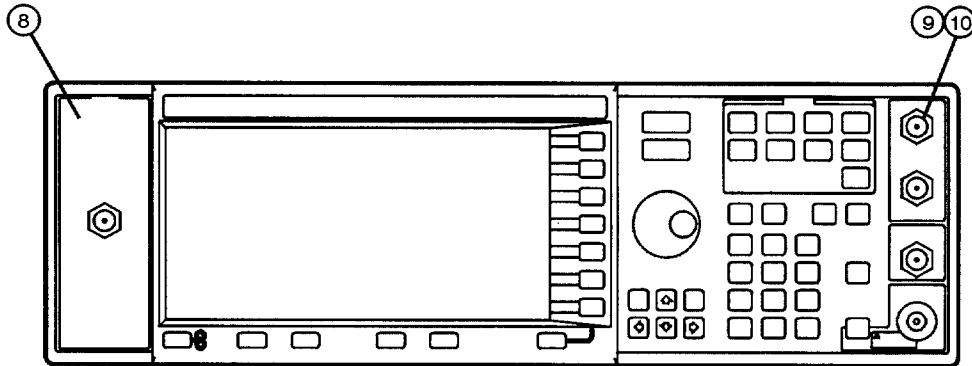

OPTION 1E6

sk799b

Front Panel View (ESG-D Series)

Refer to Table 3-27 and Figure 3-27.

Table 3-27 Front Panel View (ESG-D Series)

Item No.	Part Number	Qty	Description
1	E4400-80010	1	Label-Connectors
2	E4400-80076	1	Nameplate - E4430B 250k - 1GHz
2	E4400-80077	1	Nameplate - E4431B 250k - 2GHz
2	E4400-80078	1	Nameplate - E4432B 250k - 3GHz
2	E4400-80079	1	Nameplate - E4433B 250k - 4GHz
3	E4400-40003	1	Knob-RPG
4	E4400-80005	1	Label-Keypad
5	2950-0035	5	Nut-Hex 15/32-32
6	3050-1919	5	Washer-Wavy .490ID
7	E4400-80011	1	Label-Connectors (Option 1EM)
8	E4400-80015	1	Label-Keypad (Option 1EM)
9	E4400-80006	1	Label-Connectors (Options UN3, UN4, UN7, UN8, UND)
10	2950-0035	8	Nut-Hex 15/32-32 (Options UN3, UN4, UN7, UN8, UND)
11	3050-1919	8	Washer-Wavy .490ID (Options UN3, UN4, UN7, UN8, UND)

Figure 3-27 Front-Panel View (ESG-D Series)

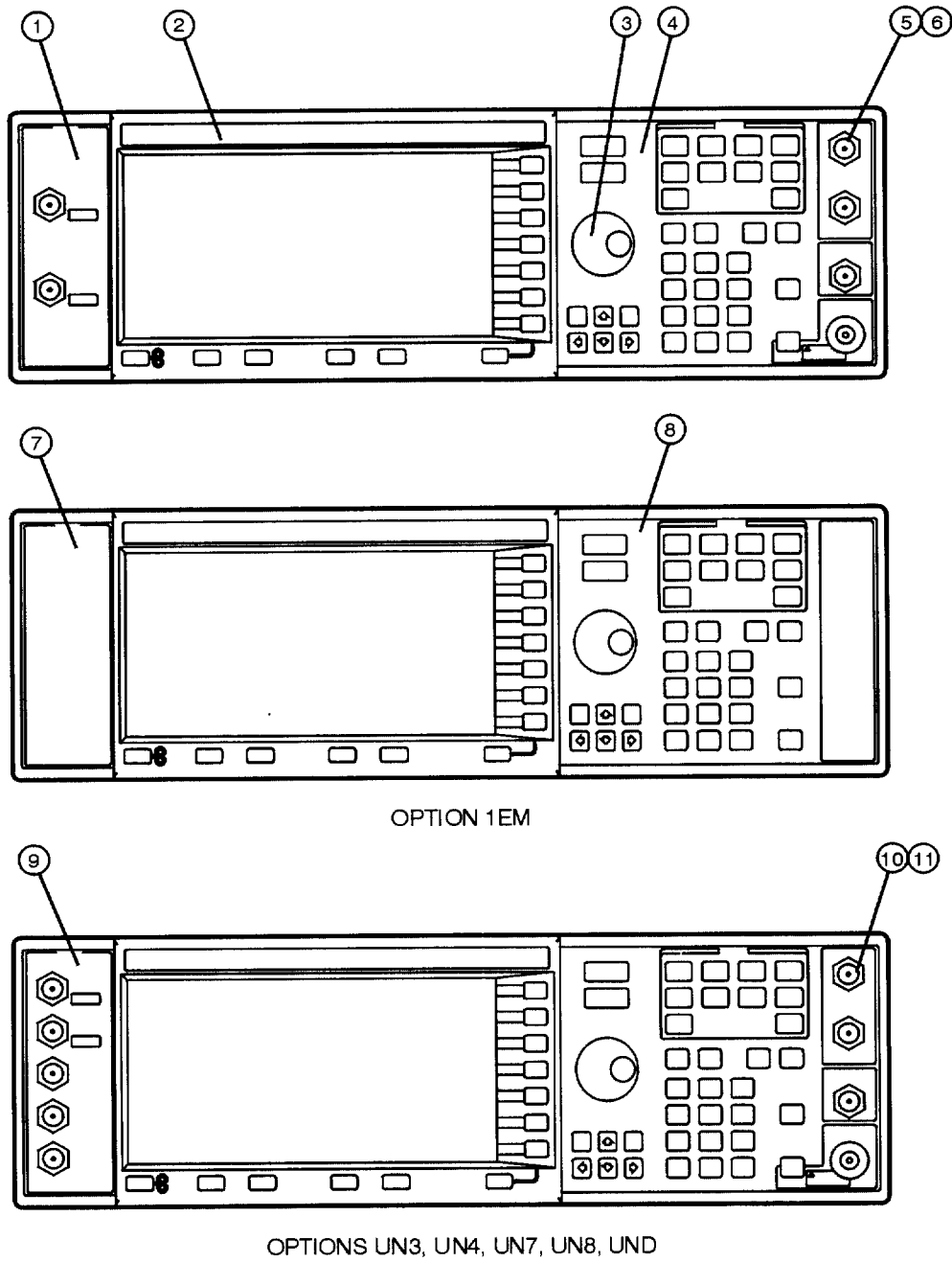

sk763b

Disassembled Front-Panel View

Refer to Table 3-28 and Figure 3-28.

Table 3-28 Disassembled Front-Panel View

Item No.	Part Number	Qty	Description
1	1250-1811	1	Adapter-Female SMA to Female Type-N
2	E4400-20012	1	Frame-Front
3	3050-1935	1	Washer-Flat
4	2190-0383	1	Washer-Lock
5	2950-0054	1	Nut-Hex 1/2-28
6	E4400-40001	1	Rubber Keypad
7	0515-1521	5	Screw-Machine M3x5 FL-TX
8	0515-0372	4	Screw-Machine M3x8 CW-PN-TX
9	1400-1594	2 ¹	Clamp-Flexible Cables
10	0515-0372	8	Screw-Machine M3x8 CW-PN-TX
11	1400-0054	1	Clamp-Semi-Rigid Cable (W9)
12	1400-1533	1	Clamp-Ribbon Cable (A1W1)
13	1400-0493	1	Cable Tie Wrap
14	1400-0611	1	Clamp-Ribbon Cable (W10)
15	E4400-00008	1	Front Frame RFI Shield
16	E4400-00009	1	Filter Bracket
17	4330-1711	1	Glass Filter 70% XMT
18	E4400-40008	1	Light Pipe
19	8160-0723	2 Ft	Spiral Gasket-BC CY .094
20	8160-0660	4 Ft	RFI Round Mesh.125
21	0515-1227	9	Screw-Machine M3x6 FL-TX

1. ESG-A Series uses a quantity of one.

Figure 3-28 Disassembled Front-Panel View

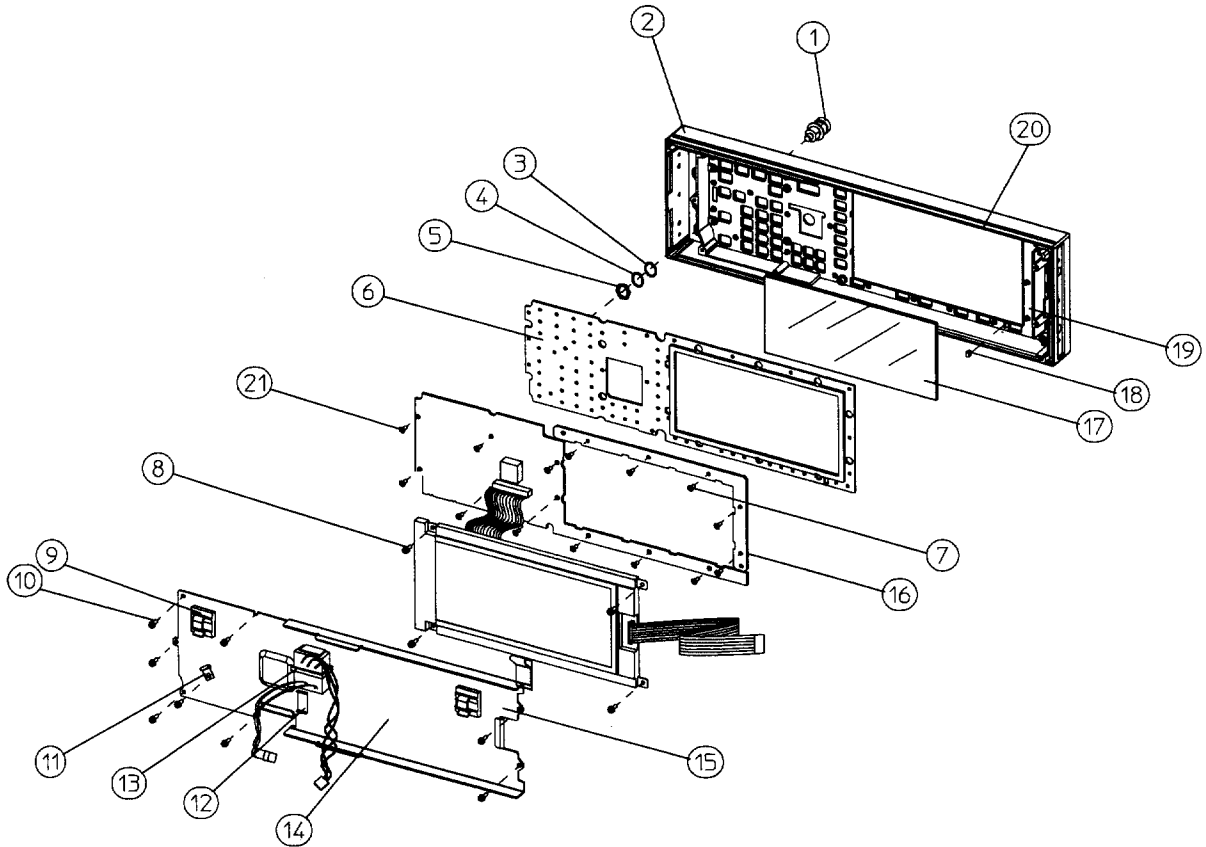

sk7148b

Daughterboard Card Cage View

Refer to Table 3-29 and Figure 3-29.

Table 3-29 Daughterboard Card Cage View

Item No.	Part Number	Qty	Description
1	E4400-40002	4	Retainer-Cable
2	0510-1643	4	Retainer Ring .309ID
3	0515-0430	5	Screw-Machine M3x6 CW-PN-TX

Figure 3-29 Daughterboard Card Cage View

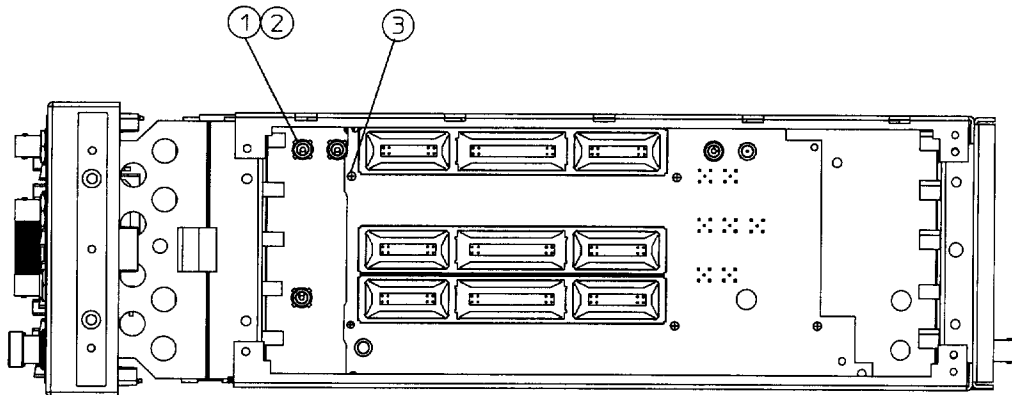

sk719b

Inside Rear-Panel View

Refer to Table 3-30 and Figure 3-30.

Table 3-30 Inside Rear-Panel View

Item No.	Part Number	Qty	Description
1	0535-0031	2	Nut-Hex M3.0

Figure 3-30 Inside Rear-Panel View

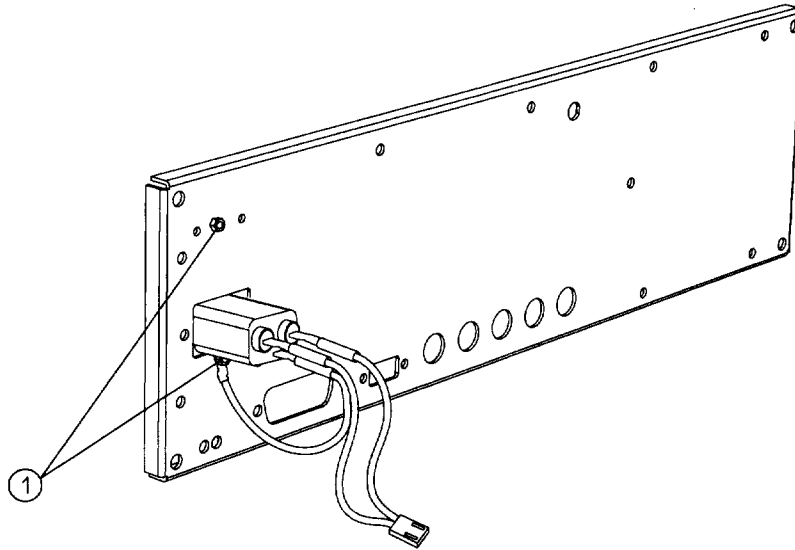

sk720b

Rear-Panel View (ESG-A Series)

Refer to Table 3-31 and Figure 3-31.

Table 3-31 Rear-Panel View (ESG-A Series)

Item No.	Part Number	Qty	Description
1	0515-0372	10	Screw-Machine M3x8 CW-PN-TX
2	E4400-00032	1	Panel-Rear
6	6960-0023	1	Plug-Hole .312D
7	E4400-00017	1	Serial Number Plate
8	0515-1102	2	Screw-Machine M3x8 FL-TX
9	0380-0644	2	Standoff-Hex .327L 6-32
10	2190-0577	2	Washer-Lock
11	0380-2079	2	Standoff-Hex .312L 4-40
12	2190-0003	2	Washer-Lock
14	2950-0054	5	Nut-Hex 1/2-28
15	2190-0068	5	Washer-Lock .505ID

Figure 3-31 Rear-Panel View (ESG-A Series)

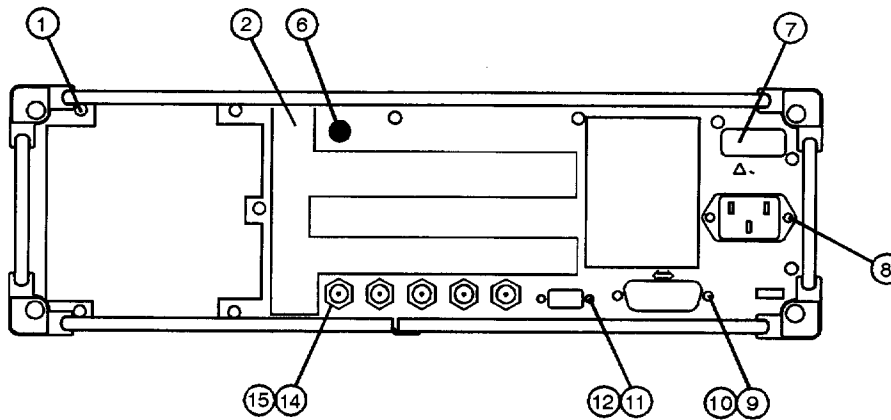

sk773a

Rear-Panel View (ESG-A Series - Option 1EM)

Refer to Table 3-32 and Figure 3-32.

Table 3-32 Rear-Panel View (ESG-A Series - Option 1EM)

Item No.	Part Number	Qty	Description
1	0515-0372	10	Screw-Machine M3x8 CW-PN-TX
2	E4400-00033	1	Panel-Rear
6	6960-0023	1	Plug-Hole .312D
7	2950-0035	3	Nut-Hex 15/32-32
8	2190-0102	3	Washer-Lock .472ID
9	08559-60002	1	RF Output Assy
10	2950-0132	1	Nut-Hex 7/16-28
11	2190-0102	1	Washer-Lock
12	6960-0002	1	Plug-Hole .500D
13	E4400-00017	1	Serial Number Plate
14	0515-1102	2	Screw-Machine M3x8 FL-TX
15	0380-0644	2	Standoff-Hex .327L 6-32
16	2190-0577	2	Washer-Lock
17	0380-2079	2	Standoff-Hex .312L 4-40
18	2190-0003	2	Washer-Lock
19	2950-0054	5	Nut-Hex 1/2-28
20	2190-0068	5	Washer-Lock .505ID

Figure 3-32 Rear-Panel View (ESG-A Series - Option 1EM)

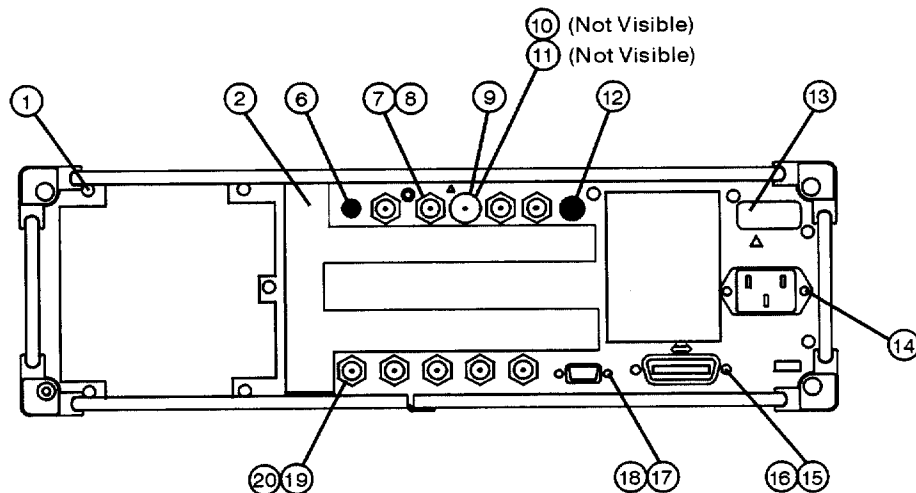

sk7100b

Rear-Panel View (ESG-D Series)

Refer to Table 3-33 and Figure 3-33.

Table 3-33 Rear-Panel View (ESG-D Series)

Item No.	Part Number	Qty	Description
1	0515-0372	10	Screw-Machine M3x8 CW-PN-TX
2	E4400-00032	1	Panel-Rear
3	0515-0372	1	Screw-Machine M3x8 CW-PN-TX (used to attach item 4))
4	1250-2759	1	Dust Cap Female SMA
5	1250-1753	1	Adapter-Female SMA to Female SMA
7	E4400-00017	1	Serial Number Plate
8	0515-1102	2	Screw-Machine M3x8 FL-TX
9	0380-0644	2	Standoff-Hex .327L 6-32
10	2190-0577	2	Washer-Lock
11	0380-2079	2	Standoff-Hex .312L 4-40
12	2190-0003	2	Washer-Lock
13	6960-0002	3	Plug-Hole .500D (Options UN3, UN4, UN8, UND)
14	2950-0054	5	Nut-Hex 1/2-28
15	2190-0068	5	Washer-Lock .505ID
16	2950-0035	11	Nut-Hex 15/32-32 (Options UN3, UN4, UN8, UND)
17	2190-0102	11	Washer-Lock .472ID (Options UN3, UN4, UN8, UND)
18	E4400-00031	1	Panel-Rear (Options UN3, UN4, UN8, UND)
19	2950-0035	14	Nut-Hex 15/32-32 (Option UN7)
20	2190-0102	14	Washer-Lock .472ID (Option UN7)
21	E4400-00025	1	Panel-Rear (Option UN7)
22	2950-0078	5	Nut-Hex 10-32 (for the SMBs) (Option UN7)
23	2190-0124	5	Washer-Lock .195ID (for the SMBs) (Option UN7)
24	2950-0078	6	Nut-Hex 10-32 (for the SMBs) (Option 300)
25	2190-0124	6	Washer-Lock .195ID (for the SMBs) (Option 300)
26	E4400-00025	1	Panel-Rear (Option 300)

Figure 3-33 Rear-Panel View (ESG-D Series)

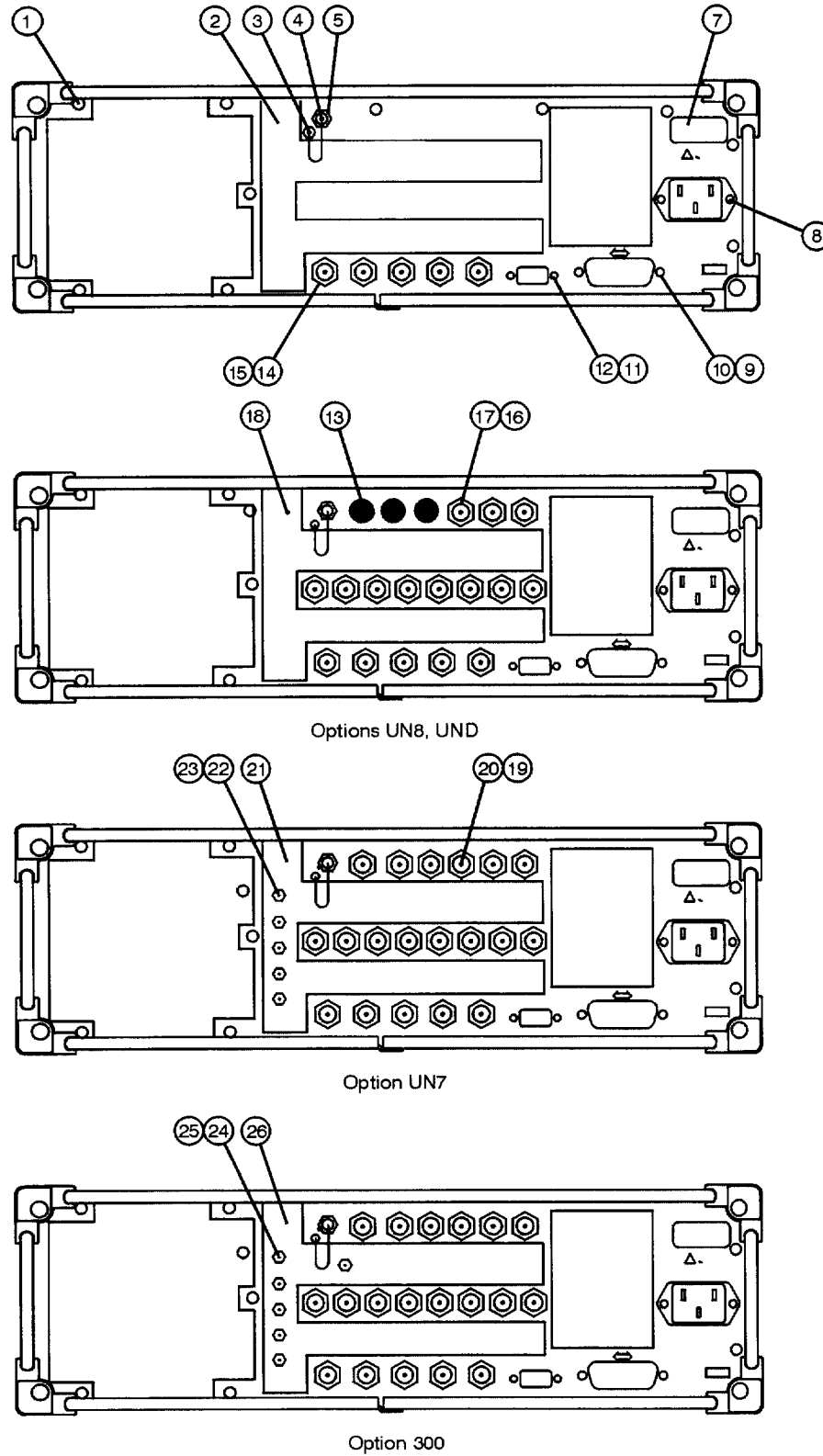

sk7101b

Rear Panel View (ESG-D Series - Option 1EM)

Refer to Table 3-34 and Figure 3-34.

Table 3-34 Rear Panel View (ESG-D Series - Option 1EM)

Item No.	Part Number	Qty	Description
1	0515-0372	10	Screw-Machine M3x8 CW-PN-TX
2	E4400-00033	1	Panel-Rear
3	0515-0372	1	Screw-Machine M3x8 CW-PN-TX (used to attach item 4)
4	1250-2759	1	Dust Cap Female SMA
5	1250-1753	1	Adapter-Female SMA to Female SMA
7	2950-0035	5	Nut-Hex 15/32-32
8	2190-0102	5	Washer-Lock .472ID
9	08559-60002	1	RF Output Assy
10	2950-0132	1	Nut-Hex 7/16-28
11	2190-0102	1	Washer-Lock
13	E4400-00017	1	Serial Number Plate
14	0515-1102	2	Screw-Machine M3x8 FL-TX
15	0380-0644	2	Standoff-Hex .327L 6-32
16	2190-0577	2	Washer-Lock
17	0380-2079	2	Standoff-Hex .312L 4-40
18	2190-0003	2	Washer-Lock
19	2950-0054	5	Nut-Hex 1/2-28
20	2190-0068	5	Washer-Lock .505ID
21	E4400-00034	1	Panel-Rear (Options UN3, UN4, UN8)
22	2950-0078	14	Nut-Hex 10-32 (for the SMBs) (Options UN3, UN4, UN8, UND)
23	2190-0124	14	Washer-Lock .195ID (for the SMBs) (Options UN3, UN4, UN8, UND)
24	E4400-00026	1	Panel-Rear (Option UN7)
25	2950-0078	22	Nut-Hex 10-32 (for the SMBs) (Option UN7)
26	2190-0124	22	Washer-Lock .195ID (for the SMBs) (Option UN7)
27	E4400-00026	1	Panel-Rear (Option 300)
28	2950-0078	22	Nut-Hex 10-32 (for the SMBs) (Option UN7)
29	2190-0124	14	Washer-Lock .195ID (for the SMBs) (Options UN3, UN4, UN8, UND)

Figure 3-34 Rear-Panel View (ESG-D Series - Option 1EM)

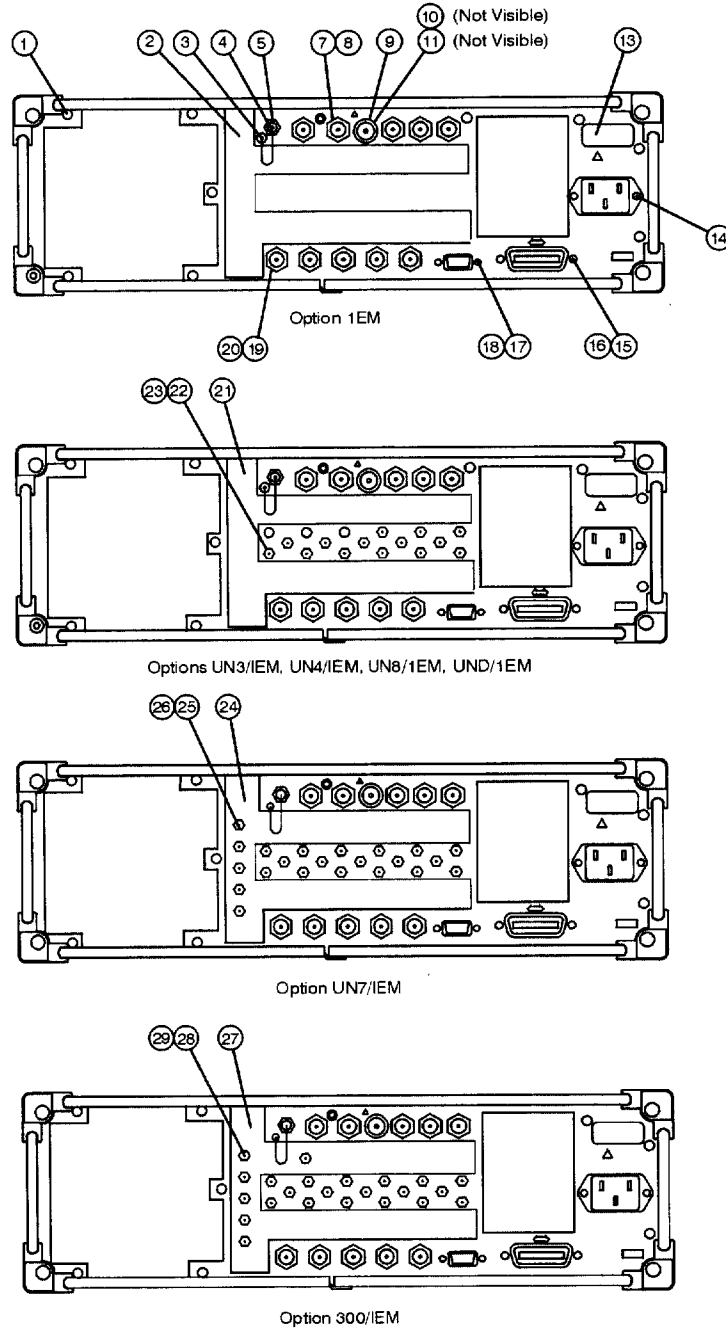

sk7102b

Instrument Chassis with Top and Right-Side Hardware

Refer to Table 3-35 and Figure 3-35.

Table 3-35 Instrument Chassis with Top and Right-Side Hardware

Item No.	Part Number	Qty	Description
1	0515-1269	2	Screw-Machine M4X10 FL-TX
2	0515-2087	4	Screw-Machine M3x6 CW-BN-TX
3	E4400-00003	1	Cover-Side (Serial Prefix US3833, or GB3832, and below)
3	E4400-00037	1	Cover-Side (Serial Prefix US3844, or GB3845, and above)
4	E4400-00035	1	Chassis
5	E4400-00036	1	Cover-Top Chassis
6	0515-0430	11	Screw-Machine M3x6 CW-PN-TX
7	E4400-80066	1	Label-Connection Diagram

Figure 3-35 Instrument Chassis with Top and Right-Side Hardware

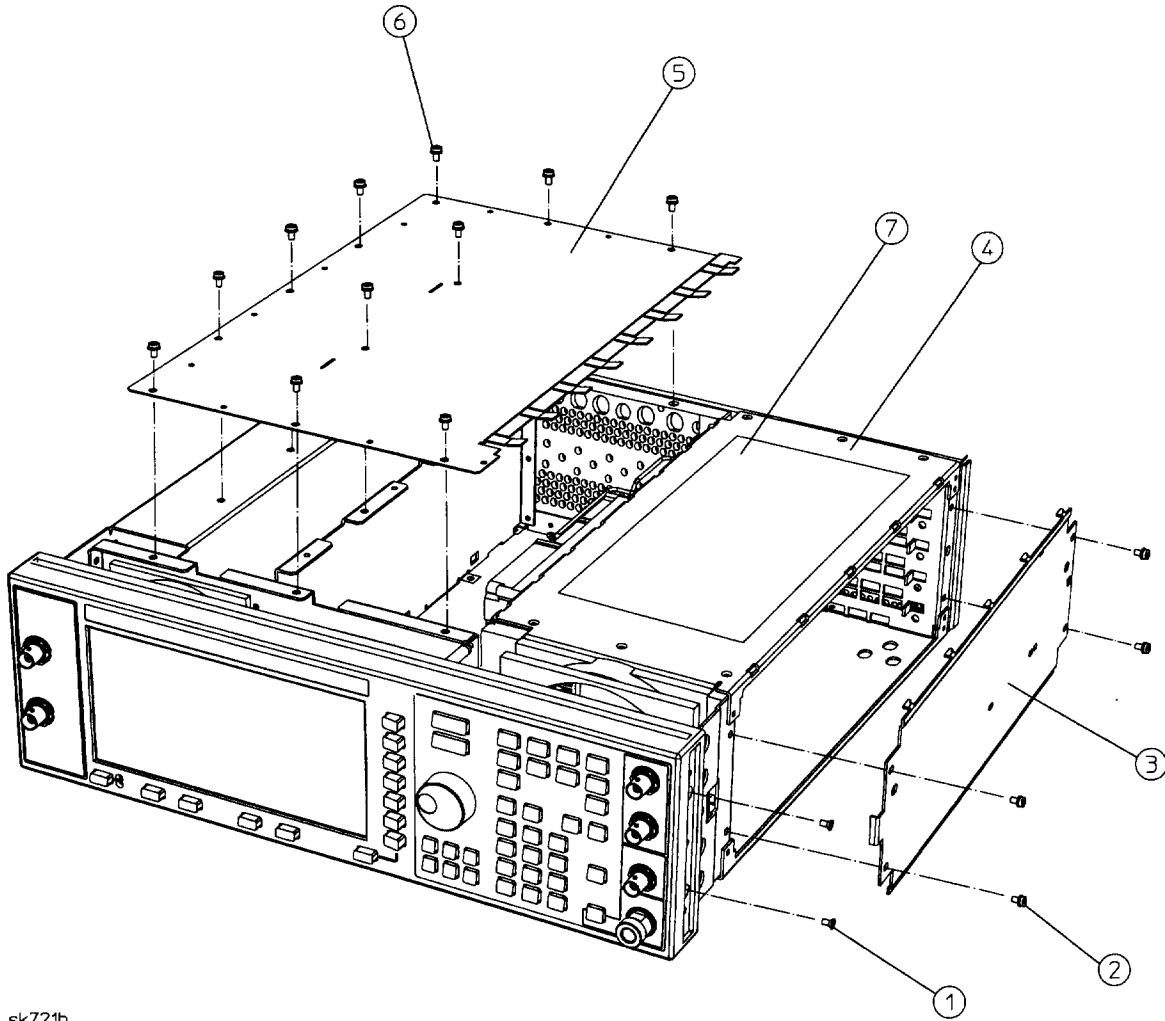

sk721b

Power Supply Shield and Left-Side Hardware

Refer to Table 3-36 and Figure 3-36.

Table 3-36 Power Supply Shield and Left-Side Hardware

Item No.	Part Number	Qty	Description
1	0515-1269	2	Screw-Machine M4X10 FL-TX
2	E4400-00011	1	Shield-Power Supply
3	0515-0372	17	Screw-Machine M3x8 CW-PN-TX

Figure 3-36 Power Supply Shield and Left-Side Hardware

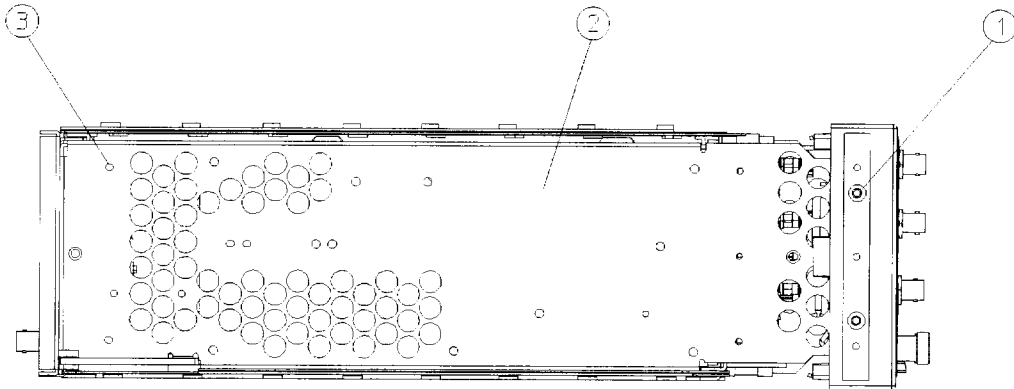

sk706a

Motherboard and Bottom-Side Hardware

Refer to Table 3-37 and Figure 3-37.

Table 3-37 Motherboard and Bottom-Side Hardware

Item No.	Part Number	Qty	Description
1	0515-0372	15	Screw-Machine M3x8 CW-PN-TX
2	E4400-00007	1	Cover-Bottom Chassis
3	0515-0372	2	Screw-Machine M3x8 CW-PN-TX

Figure 3-37 Motherboard and Bottom-Side Hardware

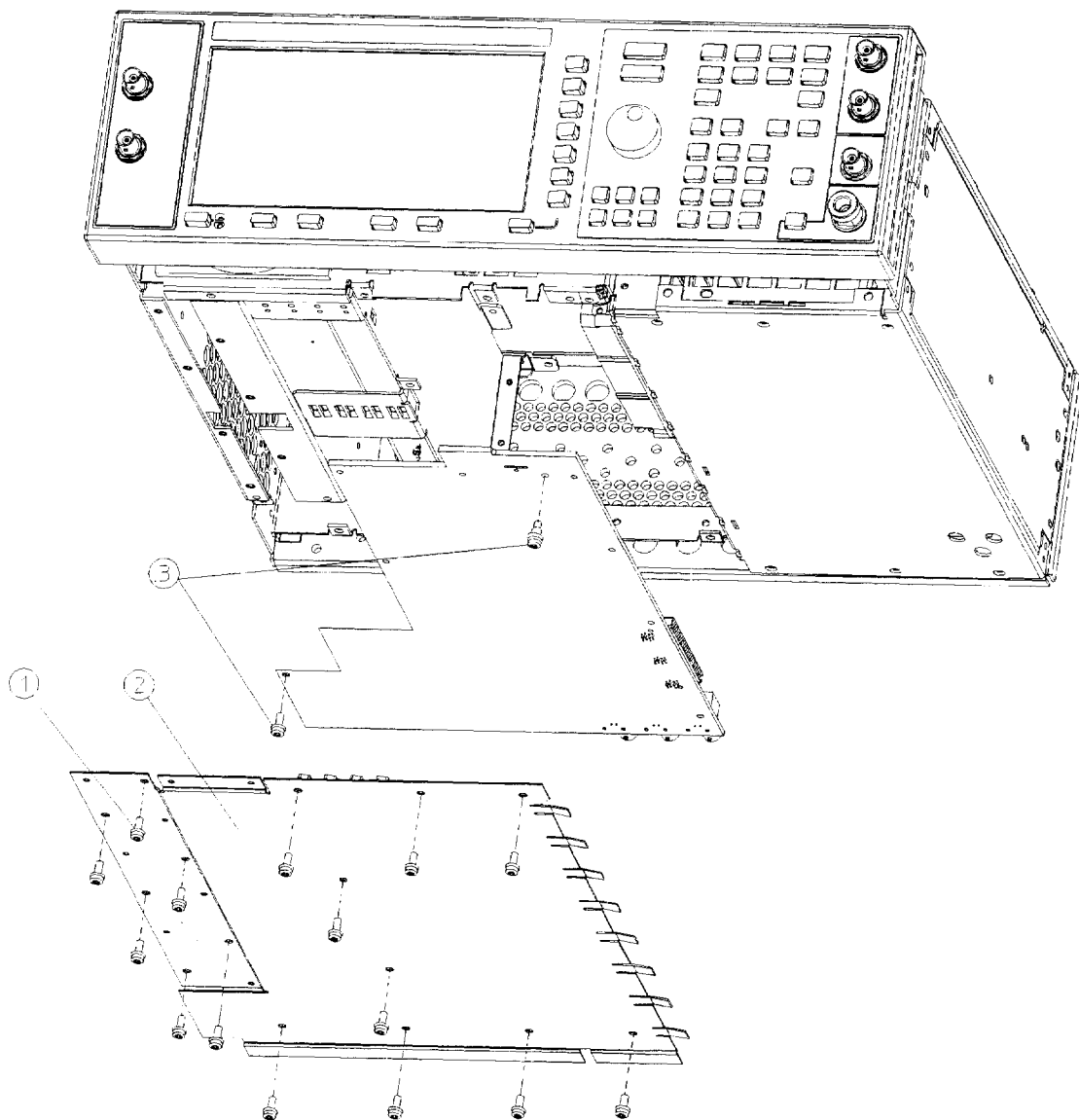

sk7104b

Instrument Cover and Associated Parts

Refer to Table 3-38 and Figure 3-38.

Table 3-38 Instrument Cover and Associated Parts

Item No.	Part Number	Qty	Description
1	0515-1619	4	Screw-Machine M4x25 PN-TX
2	5041-9611	4	Foot-Rear Long
3	5041-9167	4	Feet-Bottom
4	1460-1345	2	Spring-Wire Frame 3.000 Long
5	5041-9171	2	Side Trim
6	E4400-60026	2	Assy-Strap Handle - includes the following parts:
Item 6 includes these parts:	5063-9209	1	Strap Assembly
	E4400-00015	2	Ground Spring
	E4400-20023	2	Handle Retainer
	E4400-40007	2	End Cap
	0515-0710	2	Screw-Machine M5x18 FL-TX
7	E4400-00004	1	Cover-Instrument

Figure 3-38 Instrument Cover and Associated Parts

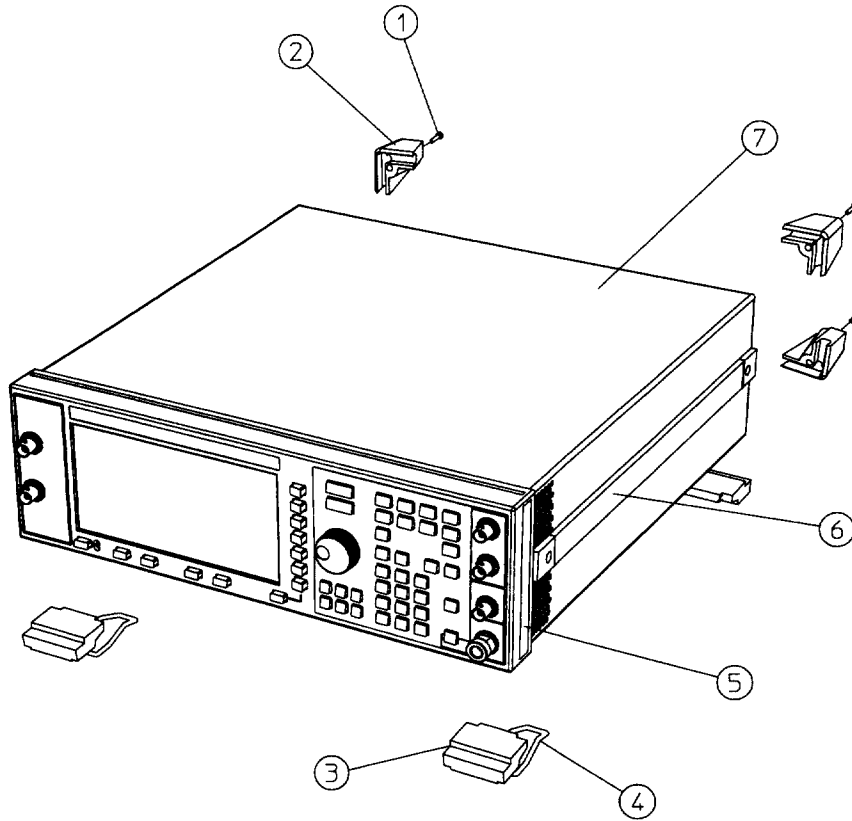

sk755b

Miscellaneous

Miscellaneous

This section lists part numbers for miscellaneous items that can be used with your signal generator. These items are categorized as follows:

- “Accessories” on page 3-72
- “Documentation” on page 3-73
- “Electrostatic Discharge (ESD) Protective Supplies” on page 3-76
- “Upgrade and Retrofit Kits” on page 3-76

Accessories

Refer to Table 3-39.

Table 3-39 Accessories

Description	Part Number
Connector End Cap-RF Output	1401-0247
Connector End Cap-GPIB	1401-5007
Connector End Cap Coherent Carrier Out	1252-4696
Remote Interface	83300A
Transit Case	9211-1296

Documentation

Refer to Table 3-40 and Table 3-41.

Table 3-40 ESG Family Signal Generators Documentation

Description	Part Number
ESG-A and ESG-AP Series Manual Set (includes items listed below)	E4400-90334
User's Guide	E4400-90323
Programming Guide	E4400-90324
Calibration Guide	E4400-90325
Quick Start Guide	E4400-90326
Error Messages	E4400-90333
Technical Specifications	5965-3096E
Feature Releases Document	E4400-90363
ESG-D and ESG-DP Series Manual Set (includes items listed below)	E4400-90322
User's Guide	E4400-90323
Programming Guide	E4400-90324
Calibration Guide	E4400-90325
Quick Start Guide	E4400-90326
Error Messages	E4400-90333
Technical Specifications	5965-3096E
Feature Releases Document	E4400-90363
Option 201 Real-Time cdma2000 Personality User's and Programming Guide	E4400-90386
Option UN8 Real-Time I/Q Baseband Generator with TDMA Standards User's and Programming Guide	E4400-90327
Option UND Dual Arbitrary Waveform Generator and Option UN5 Multichannel, Multicarrier CDMA Personality User's and Programming Guide	E4400-90328
Option 100 W-CDMA Personality User's and Programming Guide	E4400-90329
Option 101 CDMA2000 Personality User's and Programming Guide	E4400-90330
Option UN7 Bit Error Rate Test User's and Programming Guide	E4400-90331
Option 300 Base Station BERT Extension for Option UN7 User's and Programming Guide	E4400-90305
Service Guide	E4400-90335
Component-Level Information	E4400-90336

Table 3-41 Localized Documentation for ESG Family Signal Generators

Description	Part Number
Chinese	
User's Guide - Chinese	E4400-90172
Option UN8 DECT User's and Programming Guide - Chinese	E4400-90194
Option UN8 GSM User's and Programming Guide - Chinese	E4400-90201
Option UN8 Custom Digital Modulation User's and Programming Guide - Chinese	E4400-90180
Option UN8 Dual Arbitrary Waveform Generator and Option UN5 Multichannel, Multicarrier CDMA Personality User's and Programming Guide - Chinese	E4400-90187
Taiwanese	
User's Guide - Taiwanese	E4400-90173
Option UN8 DECT User's and Programming Guide - Taiwanese	E4400-90195
Option UN8 GSM User's and Programming Guide - Taiwanese	E4400-90202
Option UN8 Custom Digital Modulation User's and Programming Guide - Taiwanese	E4400-90181
Option UN8 Dual Arbitrary Waveform Generator and Option UN5 Multichannel, Multicarrier CDMA Personality User's and Programming Guide - Taiwanese	E4400-90188
French	
User's Guide - French	E4400-90174
Option UN8 DECT User's and Programming Guide - French	E4400-90196
Option UN8 GSM User's and Programming Guide - French	E4400-90203
Option UN8 TETRA User's and Programming Guide - French	E4400-90212
Option UN8 Custom Digital Modulation User's and Programming Guide - French	E4400-90182
Option UN8 Dual Arbitrary Waveform Generator and Option UN5 Multichannel, Multicarrier CDMA Personality User's and Programming Guide - French	E4400-90189
German	
User's Guide - German	E4400-90175
Option UN8 DECT User's and Programming Guide - German	E4400-90197
Option UN8 GSM User's and Programming Guide - German	E4400-90204
Option UN8 TETRA User's and Programming Guide - German	E4400-90210
Option UN8 Custom Digital Modulation User's and Programming Guide - German	E4400-90183
Option UN8 Dual Arbitrary Waveform Generator and Option UN5 Multichannel, Multicarrier CDMA Personality User's and Programming Guide - German	E4400-90190

Description	Part Number
Japanese	
User's Guide - Japanese	E4400-90176
Option UN8 DECT User's and Programming Guide - Japanese	E4400-90198
Option UN8 GSM User's and Programming Guide - Japanese	E4400-90205
Option UN8 PDC User's and Programming Guide - Japanese	E4400-90208
Option UN8 PHS User's and Programming Guide - Japanese	E4400-90209
Option UN8 Custom Digital Modulation User's and Programming Guide - Japanese	E4400-90184
Option UND Dual Arbitrary Waveform Generator and Option UN5 Multichannel, Multicarrier CDMA Personality User's and Programming Guide - Japanese	E4400-90191
Option UN7 Bit Error Rate Test User's and Programming Guide - Japanese	E4400-90179
Korean	
User's Guide - Korean	E4400-90177
Option UND Dual Arbitrary Waveform Generator and Option UN5 Multichannel, Multicarrier CDMA Personality User's and Programming Guide - Korean	E4400-90192
Spanish	
User's Guide - Spanish	E4400-90178
Option UN8 DECT User's and Programming Guide - Spanish	E4400-90200
Option UN8 GSM User's and Programming Guide - Spanish	E4400-90207
Option UN8 TETRA User's and Programming Guide - Spanish	E4400-90211
Option UN8 Custom Digital Modulation User's and Programming Guide - Spanish	E4400-90186
Option UND Dual Arbitrary Waveform Generator and Option UN5 Multichannel, Multicarrier CDMA Personality User's and Programming Guide - Spanish	E4400-90193

Electrostatic Discharge (ESD) Protective Supplies

Refer to Table 3-42.

Table 3-42 Electrostatic Discharge (ESD) Protective Supplies

Description	Part Number
2 X 4 Ft Antistatic Table Mat with 15 Ft Ground Wire	9300-0797
5 Ft Grounding Cord (for wrist strap)	9300-0980
Adjustable Antistatic Wrist Strap	9300-1367
Antistatic Heel Strap (for use on conductive floors)	9300-1126

Upgrade and Retrofit Kits

Refer to Table 3-43.

Table 3-43 Upgrade and Retrofit Kits

Description	Part Number
Kit-Firmware Upgrade	E4400-60174
Kit-Firmware Upgrade with ESG-A Series Manual Set	E4400-60171
Kit-Firmware Upgrade with ESG-D Series Manual Set	E4400-60172
Kit-RS-232 Cable	E4400-60049
Kit-Rack Mount Flanges without Handles (Option 1CM)	5063-9214
Kit-Rack Mount Flanges with Handles (Option 1CP)	5063-9221
Retrofit Kit-Rack Slide for Rack Mount	5182-1272
Retrofit Kit-Modified Rack Rail for Rack Mount	5182-1273
Retrofit Kit-High Stability Timebase (conversion to Option 1E5)	E4400-60032
Retrofit Kit-Add Option UND to ESG-D Series	E4400-60166
Retrofit Kit-Retrofit Option UN3 or UN4 to include Option UN7	E4400-60143
Retrofit Kit-Upgrade Option UN3 to UN8	E4400-60160
Retrofit Kit-Upgrade Option UN4 to UN8 to include Option UN9	E4400-60184
Retrofit Kit-Upgrade Add Option UN8 to ESG-D Series	E4400-60170
Retrofit Kit-Upgrade Add Option UN9 (Options UN8 and UN9) to ESG-D Series	E4400-60185

4 Replaceable Parts (ESG-AP and ESG-DP Series)

This chapter provides important ordering information and lists the part numbers for the various replaceable parts, kits, and accessories available for your signal generator. This chapter is also useful for locating and identifying assemblies and cables.

Ordering Information

To order a part listed in the replaceable parts lists, do the following:

1. Determine the part number.
2. Determine the quantity required.
3. Mail this information to the nearest Agilent Technologies office or, in the U.S., call the hotline number listed in the following section.

To order a part not listed in the replaceable parts lists, mail the following information to the nearest Agilent Technologies office or, in the U.S., call the hotline number listed in the following section.

1. the instrument model number
2. the serial number and options, if any (see rear panel)
3. a description of the part
4. a description of the part's function
5. the quantity required

Call (800) 227-8164 to Order Parts Fast (U.S. Only)

When you have gathered the information required to place an order, contact Agilent Technologies' direct ordering team by calling the toll-free hotline number shown above. Orders may be placed Monday through Friday, 6 AM to 5 PM (Pacific Standard Time).

The parts specialists have direct on-line access to replacement parts inventory corresponding to the replaceable parts lists in this manual. Four day delivery time is standard; there is a charge for hotline one-day delivery.

This information applies to the United States only. Outside the United States, you must contact the nearest Agilent Technologies sales and service office. (Refer to Table 1-1 on page 1-8.)

Save Money with Rebuilt-Exchange Assemblies

Under the rebuilt-exchange assembly program, certain factory-repaired and tested assemblies are available on a trade-in basis. These assemblies cost less than a new assembly, and meet all factory specifications required of a new assembly.

The defective assembly must be returned for credit under the terms of the rebuilt-exchange assembly program. The figure below illustrates the assembly exchange procedure in flowchart format.

Assembly Exchange Procedure

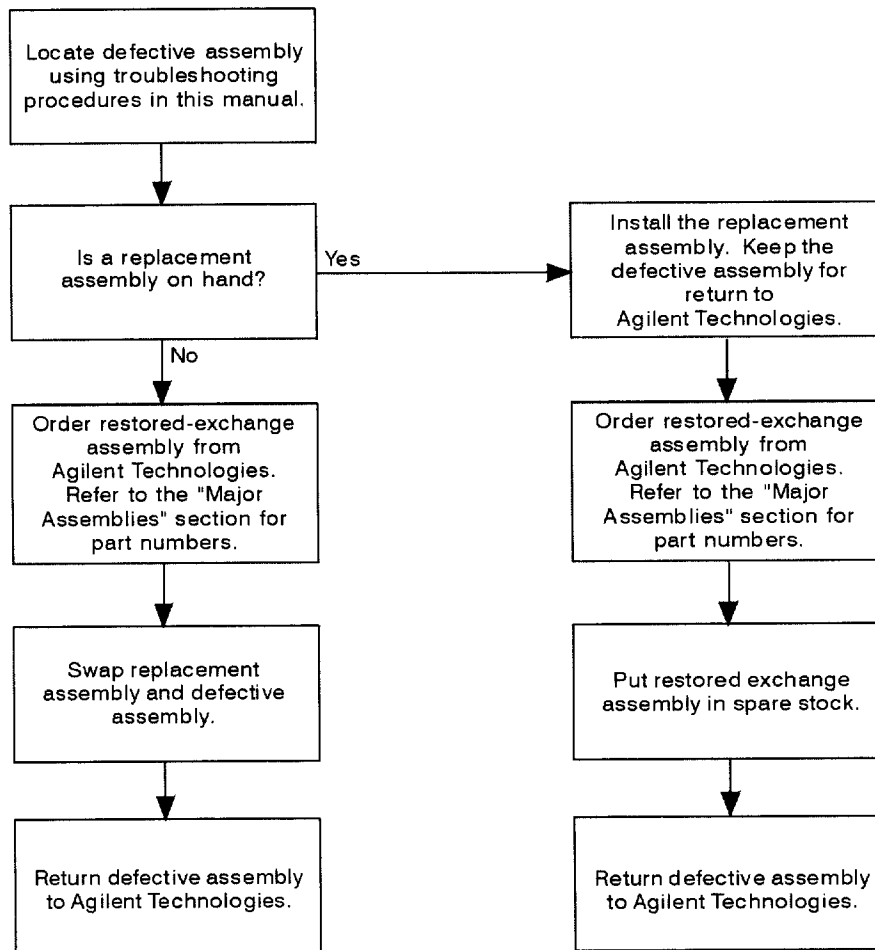

Shipping the Defective Assembly Back to Agilent Technologies

1. When you receive the rebuilt assembly, be careful not to damage the box in which it was shipped. You will use that box to return the defective assembly. The box you receive should contain the following:
 - the rebuilt assembly
 - an exchange assembly failure report
 - a return address label
2. Complete the failure report.
3. Place the failure report and the defective assembly in the box. Be sure to remove the enclosed return address label.
4. Seal the box with tape.

If you are inside the United States, stick the preprinted return address label over the label that is already on the box and return the box to Agilent Technologies. (Agilent Technologies pays postage on boxes mailed within the United States.)

If you are outside the USA, do not use the return address label; instead, address the box to the nearest Agilent Technologies sales and service office. (Refer to Table 1-1 on page 1-8.)

Abbreviations Used in Part Descriptions

This section defines the reference designators, abbreviations, and option numbers that are used in the part descriptions throughout this chapter.

Reference Designations

Reference Designator	Definition
A	assembly
AT	attenuator
B	fan
DS	lamp
J	electrical connector; jack
P	electrical connector; plug
W	cable; transmission path; wire

Abbreviations

Abbreviation	Definition
Assy	assembly
Bd	board
BC	beryllium
BN	buttonhead (screws)
CPU	central processing unit
CW	conical washer (screws)
CY	copper
D	diameter
ESD	electrostatic discharge
EXT	external
FL	flathead (screws)
Ft	feet
Hex	hexagonal
GPIB	general purpose interface bus
HX	hexagonal recess (screws)
I	in-phase
ID	inside diameter
L	length

Abbreviation	Definition
LF	low frequency
M	meters or metric hardware
OD	outside diameter
PC	patch lock (screws) or printed circuit
PN	panhead (screws)
Q	quadrature
Qty	quantity
REF	reference
RF	radio frequency
RFI	radio frequency interference
RPP	reverse power protection
SH	socket head cap (screws)
SMA	subminiature type-A
SMB	subminiature type-B
TX	TORX recess (screws)
V	volt

Options

Options	Definition
1E6	High Performance Pulse Input
1EM	Rear Panel Connections
UN7	Bit Error Rate Test
UN8	Real-Time I/Q Baseband Generator - 1 Meg
UN9	Adds 7 Meg RAM to UN8
UNA	Alternate Timeslot Power
UNB	High Power with Mechanical Attenuator
UND	Dual Arbitrary Waveform Generator

Major Assemblies

This section lists part numbers for the major assemblies in your signal generator. The following instrument views are provided to help you locate specific assemblies.

- “Top View” on page 4-8
- “Right Side Assemblies” on page 4-10
- “Disassembled Front Panel View” on page 4-11
- “Inside Rear Panel View” on page 4-12

Top View

Refer to Table 4-1 and Figure 4-1.

Table 4-1 Top View

Reference Designator	Part Number	Qty	Description
A4	0950-2791	1	Assy-Power Supply
A5	E4400-60187	1	Bd Assy-Dual Arbitrary Waveform Generator (Option UND)
A5	E4400-69187		Exchange Bd Assy-Dual Arbitrary Waveform Generator (Option UND)
A6	E4400-60072	1	Bd Assy-Bit Error Rate Test (Option UN7)
A6	E4400-69072		Exchange Bd Assy-Bit Error Rate Test (Option UN7)
A7	E4400-60070	1	Bd Assy-Real-Time I/Q Baseband Generator (Options UN8, UN8+UN9)
A7	E4400-69070		Exchange Bd Assy-Real-Time I/Q Baseband Generator (Options UN8, UN8+UN9)
A8	E4400-60154	1	Bd Assy-Flex Data Generator, 1 Meg (Option UN8)
A8	E4400-69154		Exchange Bd Assy-Flex Data Generator, 1 Meg (Option UN8)
A8	E4400-60195	1	Bd Assy-Flex Data Generator (Option UN8+UN9)
A8	E4400-69195		Exchange Bd Assy-Flex Data Generator (Option UN8+UN9)
A14	E4400-60225	1	Replacement Kit -CPU/Motherboard
A14BT1	1420-0338	1	Battery-Lithium
AT1	E4400- 60007	1	Assy-Electronic Attenuator/RPP
AT1	E4400-69007		Exchange Assy-Electronic Attenuator/RPP
AT1	E4400-60042	1	Assy-Electronic Attenuator/RPP (Option UNA)
AT1	33322-60014	1	Assy-Mechanical Attenuator (Option UNB)
A19	08648-60025	1	Assy-RPP (Option UNB)
A22	E4423-60024	1	YIG Driver Assembly
A25	08648-60010	1	Pulse Modulator Assembly (Option 1E6)
B1	3160-1040	1	Assy-Fan, Small
B2	E4400-60062	1	Kit-Fan, Large (includes 2 foam strips)

Figure 4-1 Top View

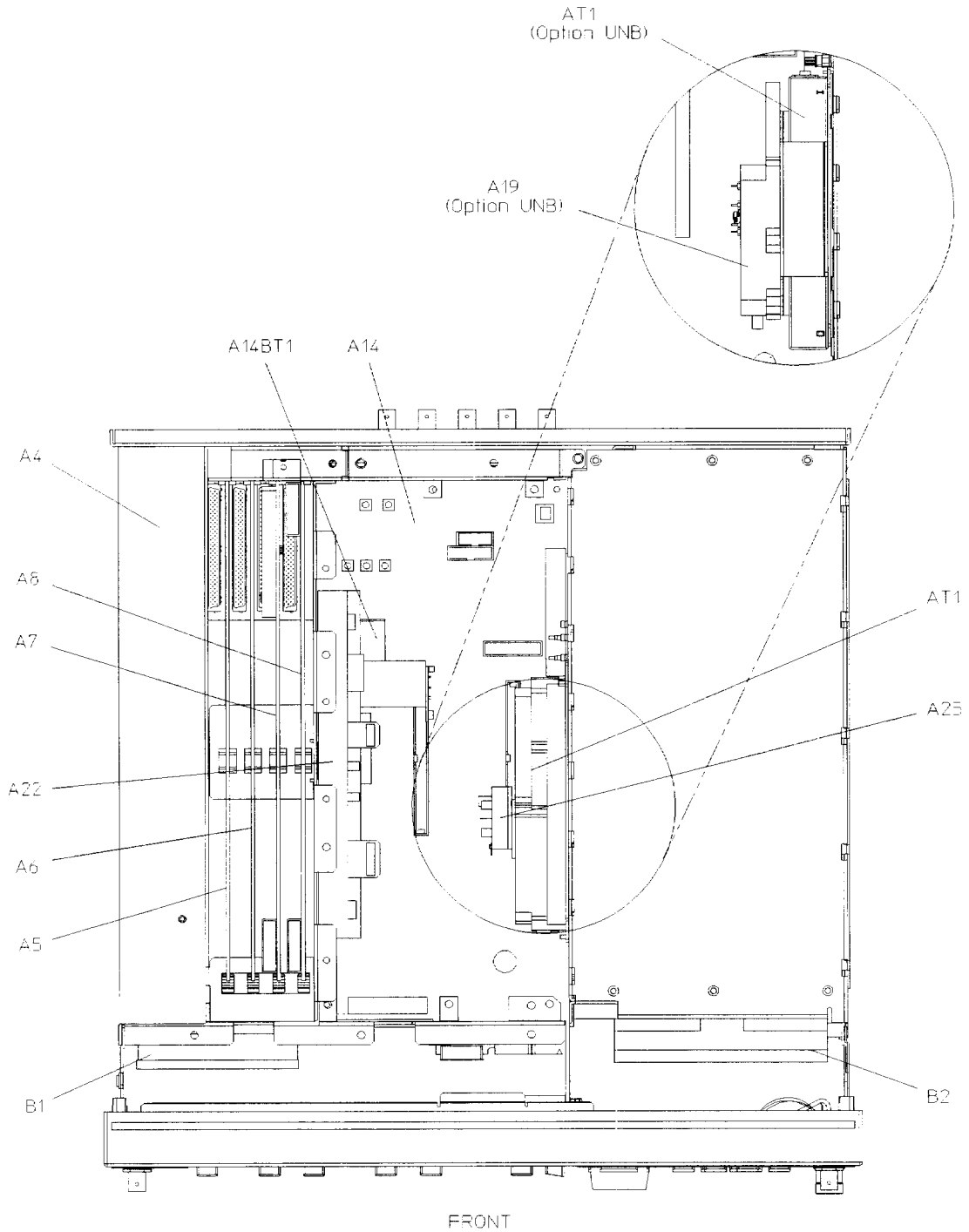

sl-7122b

Right Side Assemblies

Refer to Table 4-2 and Figure 4-2.

Table 4-2 Replaceable Assemblies, Right Side

Reference Designator	Part Number	Qty	Description
A9	E4423-60022	1	Bd Assy-Output
A9	E4423-69022	1	Exchange Bd Assy-Output
A9	E4423-60030	1	Bd Assy-Output (All models with Option UNB)
A9	E4400-69030	1	Exchange Bd Assy-Output (All models with Option UNB)
A11	E4423-60018	1	Bd Assy-Reference
A11	E4423-69018	1	Exchange Bd Assy-Reference
A15	E4423-60021	1	Bd Assy-Daughter
A15	E4423-69021	1	Exchange Bd Assy-Daughter
A23	E4423-60020	1	Bd Assy-Sampler
A23	E4423-69020	1	Exchange Bd Assy-Sampler
A24	E4423-60019	1	Bd Assy-Frac-N/Divider
A24	E4423-69019	1	Exchange Bd Assy-Frac-N/Divider

Figure 4-2 Right Side View

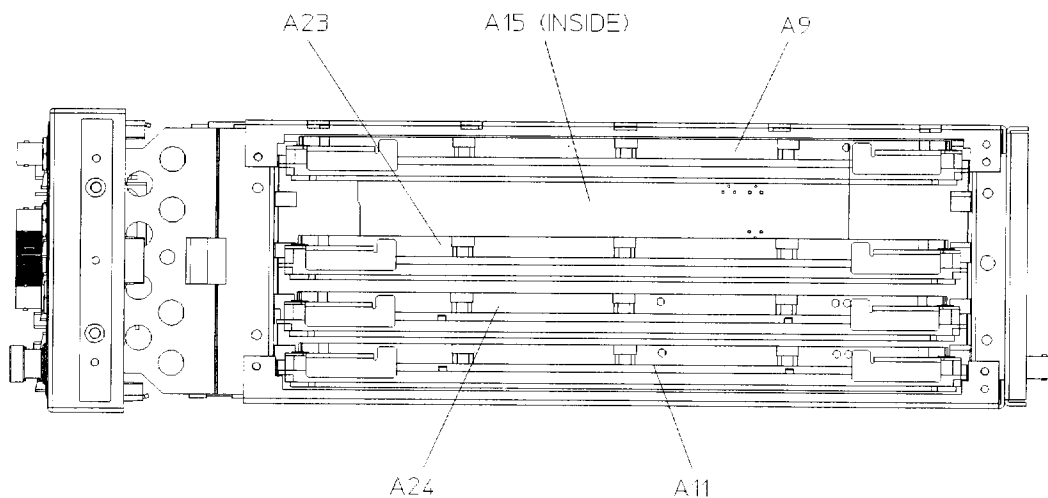

sk715b

Disassembled Front Panel View

Refer to Table 4-3 and Figure 4-3.

Table 4-3 Disassembled Front Panel View

Reference Designator	Part Number	Qty	Description
A1	E4400-60211	1	Bd Assy-Front Panel
A2	2090-0375	1	Assy-Display, Wide-Angle View
A2DS1	1513-5204	1	Lamp-Fluorescent
A3	0950-3093	1	Assy-Inverter

Figure 4-3 Disassembled Front Panel View

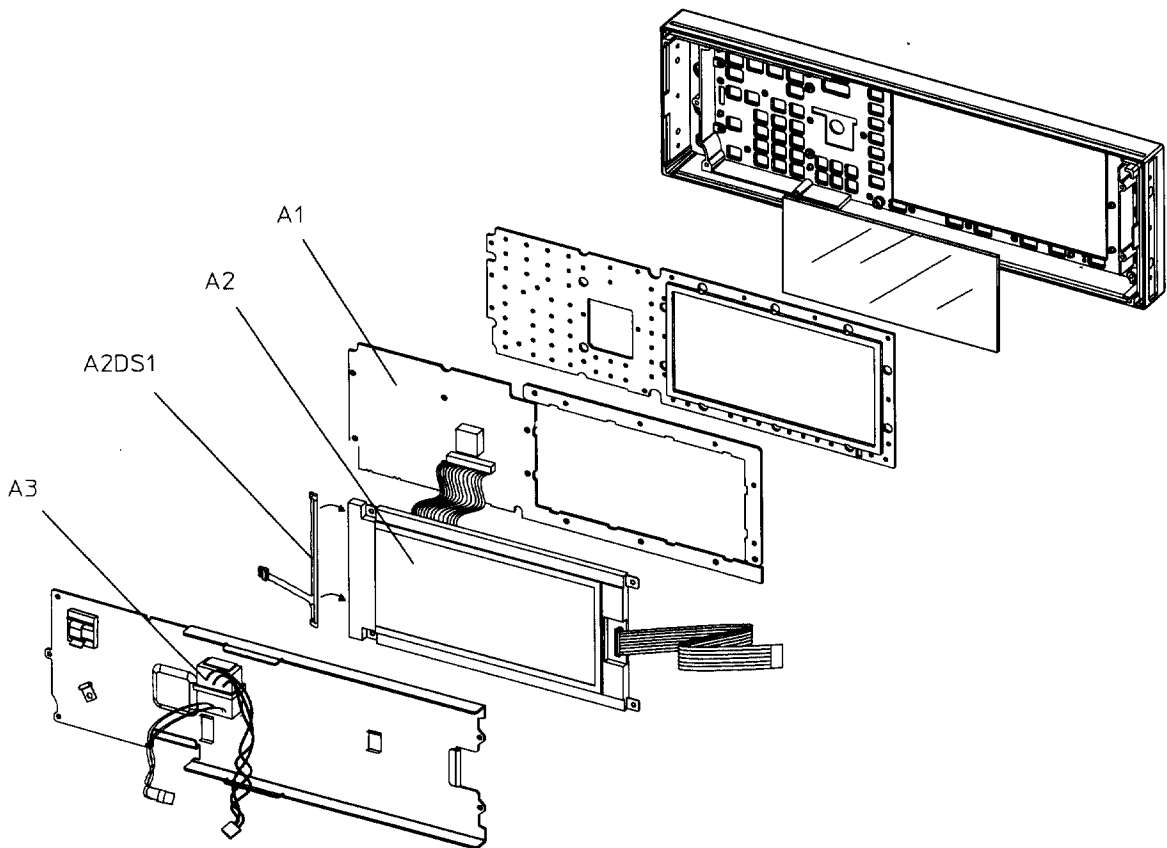

sk7147b

Inside Rear Panel View

Refer to Table 4-4 and Figure 4-4.

Table 4-4 Inside Rear Panel View

Reference Designator	Part Number	Qty	Description
A16	5063-9711	1	Assy-Line Module
A17	E4400-60145	1	Bd Assy-Rear Panel Interface (ESG-DP Series)
A17	E4400-60146	1	Bd Assy-Rear Panel Interface (ESG-DP Series Option 1EM)
A18	E4400-60075	1	Bd Assy Rear Panel Interface Subminiature Type-B (ESG-DP Series Option UN7)

Figure 4-4 Inside Rear Panel View

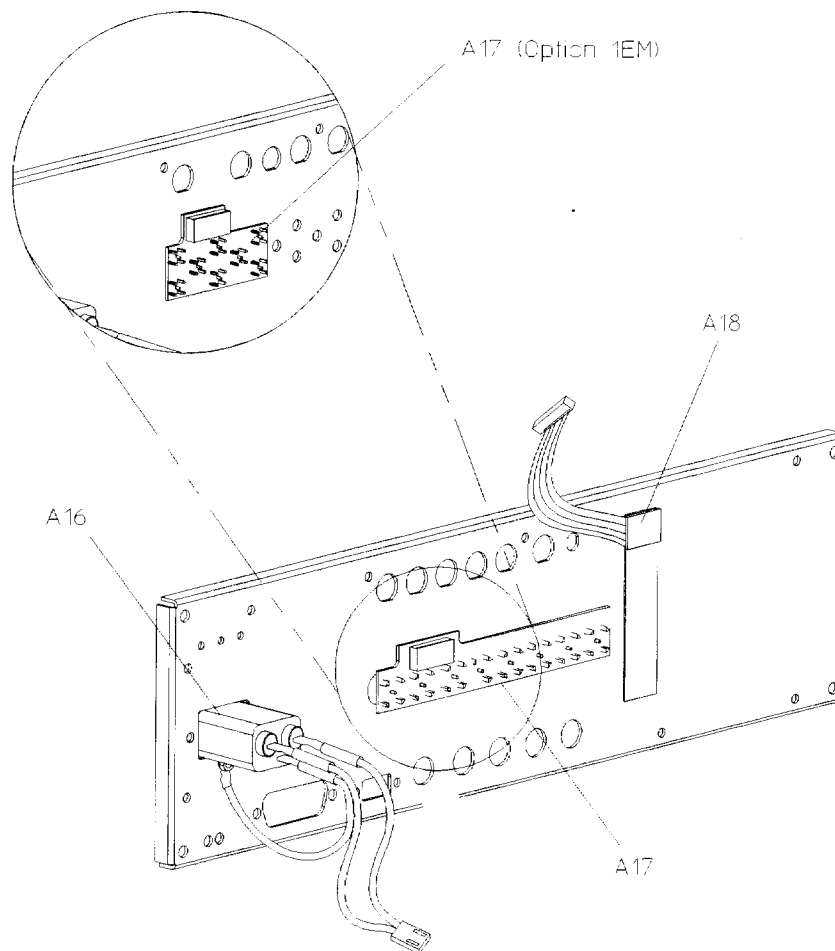

sk72b

Cables

This section lists part numbers for the cables in your signal generator. The following instrument views are provided to help you locate specific cables.

- “Top View” on page 4-14
- “Top View (ESG-DP Series - Options UN7, UN8)” on page 4-16
- “Top View (ESG-DP Series - Option UND)” on page 4-18
- “Top View (ESG-DP Series - Options UN7, UN8 with 1EM)” on page 4-20
- “Top View (ESG-DP Series - Options UN7, UN8, UND)” on page 4-22
- “Top View (ESG-DP Series - Option UND with 1EM)” on page 4-24
- “Side View — YIG Driver Assembly” on page 4-26
- “Inside Front Panel View” on page 4-28
- “Electronic Attenuator/RPP View” on page 4-30
- “Electronic Attenuator/RPP View (with Option 1EM)” on page 4-32
- “Mechanical Attenuator View (Option UNB)” on page 4-34
- “Mechanical Attenuator View (Option UNB with 1EM)” on page 4-36
- “Pulse Modulator View (Option 1E6)” on page 4-38

Top View

Refer to Table 4-5 and Figure 4-5.

Table 4-5 Top View (ESG-AP Series)

Reference Designator	Part Number	Qty	Description
A4W1 ¹	(part of A4)	1	Power Supply (A4) to CPU/Motherboard (A14J6)
A16W1 ¹	(part of A16)	1	Line Module (A16) to Power Supply (A4J1)
A16W2 ¹	(part of A16)	1	Line Module (A16) to Chassis Ground Post on Rear Panel
A22	E4423-60024	1	YIG Output Loop Assembly
W35	8120-8789	1	Ribbon Cable, YIG Driver (A22) to Motherboard (A14, J26)
W36	8120-8784	1	Flexible Cable, Daughterboard (A15, YTO FM) to YIG Driver (A22)
W37	8120-8784	1	Flexible Cable, Daughterboard (A15, PH Lock) to YIG Driver (A22)
W38	8120-8788	1	Ribbon Cable, YIG Driver (A22) to YIG Driver Oscillator Assembly (part of A22)

1. This cable is not replaceable by itself. You must order the corresponding assembly.

Figure 4-5 Top View

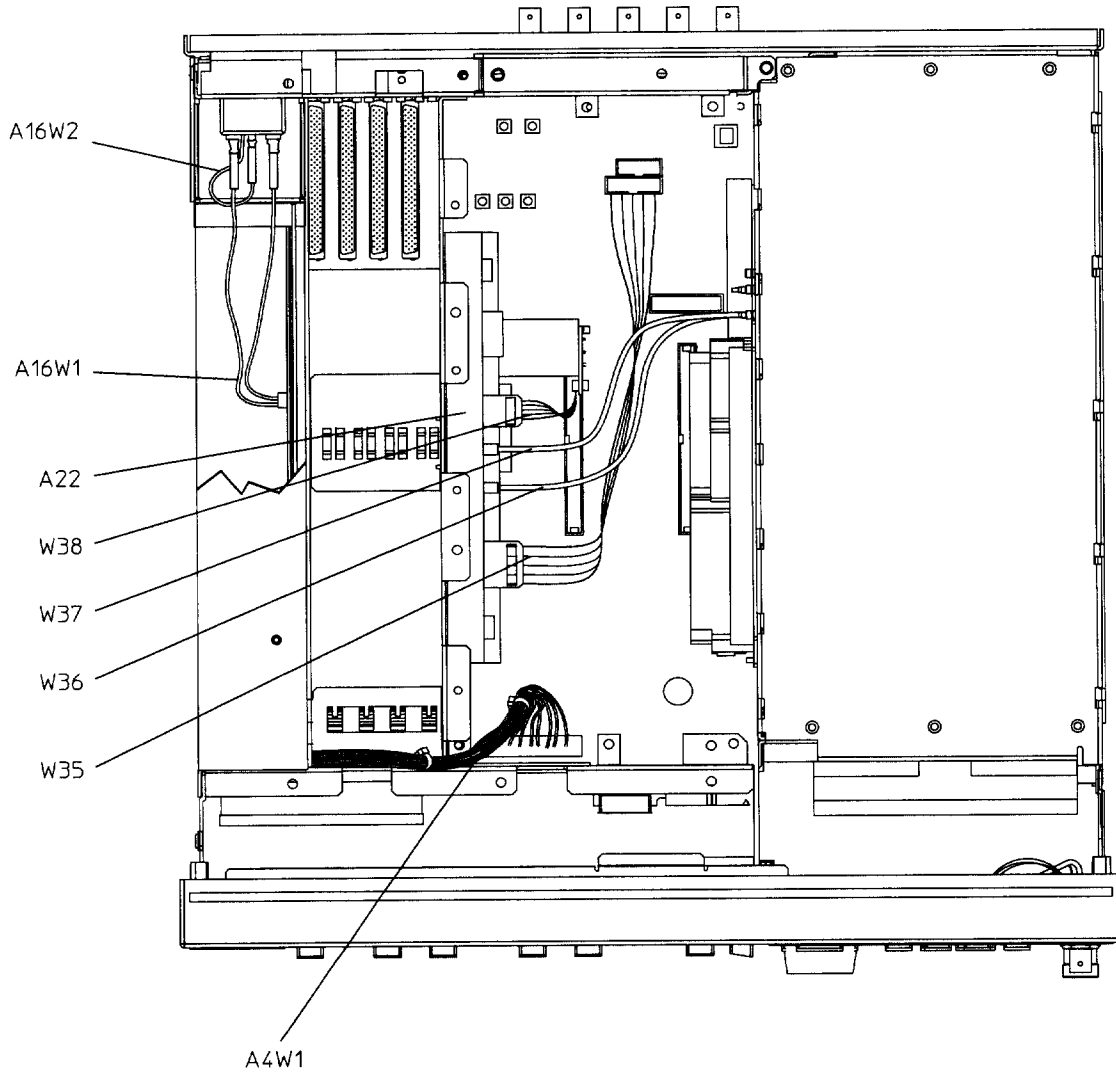

sk7125b

Top View (ESG-DP Series - Options UN7, UN8)

Refer to Table 4-6 and Figure 4-6.

Table 4-6 Top View (ESG-DP Series - Options UN7, UN8)

Reference Designator	Part Number	Qty	Description
A4W1 ¹	(part of A4)	1	Power Supply (A4) to CPU/Motherboard (A14J6)
A16W1 ¹	(part of A16)	1	Line Module (A16) to Power Supply (A4J1)
A16W2 ¹	(part of A16)	1	Line Module (A16) to Chassis Ground Post on Rear Panel
A18W1 ¹	(part of A18)	1	BERT Rear Panel Interface Board (A18) to BERT (A6)
W3	8120-5063	1	DATA to Data Generator (A8J2)
W4	8120-5063	1	DATA CLOCK to Data Generator (A8J1)
W5	8120-5063	1	SYMBOL SYNC to Data Generator (A8J3)
W15	8120-5055	1	Baseband Generator (A7P403) to BASEBAND GENREF IN
W16	8120-5055	1	Baseband Generator (A7P404) to Rear Panel (Q OUT)
W17	8120-5055	1	Baseband Generator (A7P405) to Rear Panel (I OUT)
W18	8120-8457	1	Rear Panel Interface Board (A17) to Data Generator (A8P2) and Baseband Generator (A7P2) (Option UN8 - connects in three places)
W19	8120-8349	1	Baseband Generator (A7P300) to Data Generator (A8P3) (Option UN8)
W21	8120-5055	1	Bit Error Rate Test Board (A6) to BER GATE IN (Options UN8, UN7)
W22	8120-5055	1	Bit Error Rate Test Board (A6) to BER CLK IN (Options UN8, UN7)
W23	8120-5055	1	Bit Error Rate Test Board (A6) to BER DATA IN (Options UN8, UN7)
W27	8120-8725	1	16-Pin Ribbon Cable, Parallel Data In, Data Generator (A8) to Baseband Generator (A7)

1. This cable is not replaceable by itself. You must order the corresponding assembly.

Figure 4-6 Top View (ESG-DP Series - Options UN7, UN8)

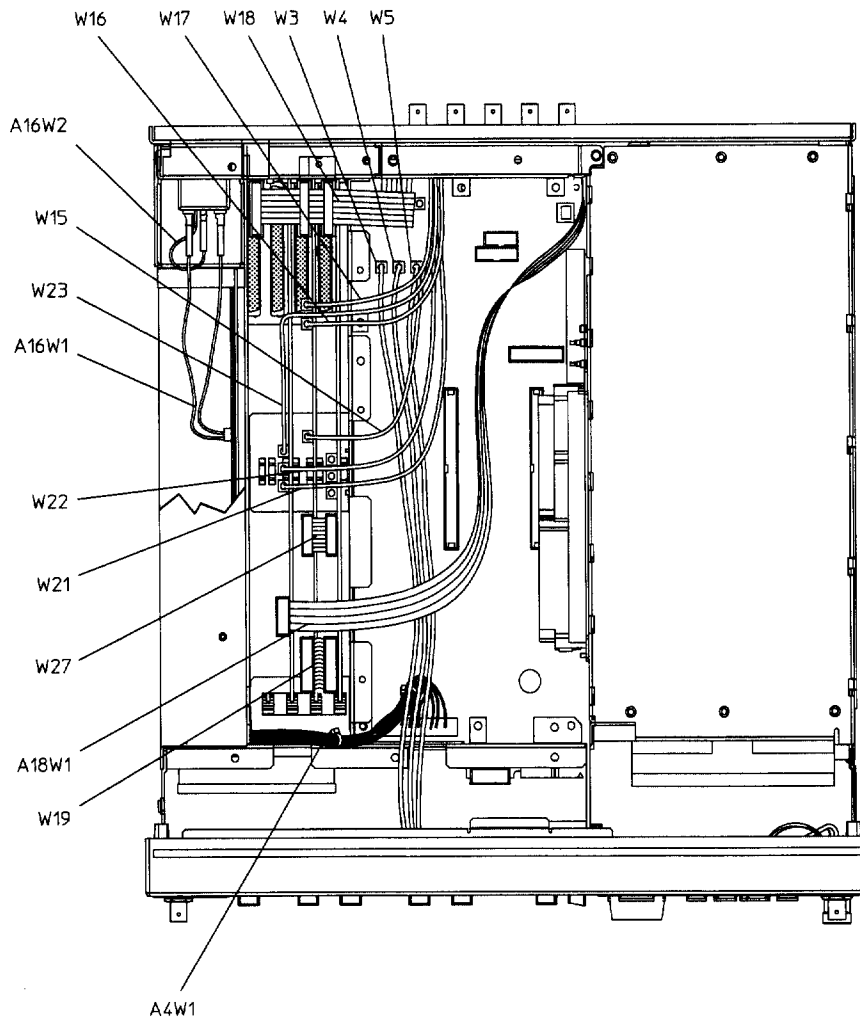

sk762b

Top View (ESG-DP Series - Option UND)

Refer to Table 4-7 and Figure 4-7.

Table 4-7 Top View (ESG-DP Series - Option UND)

Reference Designator	Part Number	Qty	Description
A4W1 ¹	(part of A4)	1	Power Supply (A4) to CPU/Motherboard (A14J6)
A16W1 ¹	(part of A16)	1	Line Module (A16) to Power Supply (A4J1)
A16W2 ¹	(part of A16)	1	Line Module (A16) to Chassis Ground Post on Rear Panel
W15	8120-5055	1	Dual Arb Waveform Generator (A5) to BASEBAND GEN REF
W16	8120-5055	1	Dual Arb Waveform Generator (A5) to Q OUT
W17	8120-5055	1	Dual Arb Waveform Generator (A5) to I OUT
W18	8120-8457	1	Rear Panel Interface Board (A17) to Data Generator (A8P2), Baseband Generator (A7P2), and Dual Arb Waveform Generator (A5) (Option UN8 - connects in three places)

1. This cable is not replaceable by itself. You must order the corresponding assembly.

Figure 4-7 Top View (ESG-DP Series - Option UND)

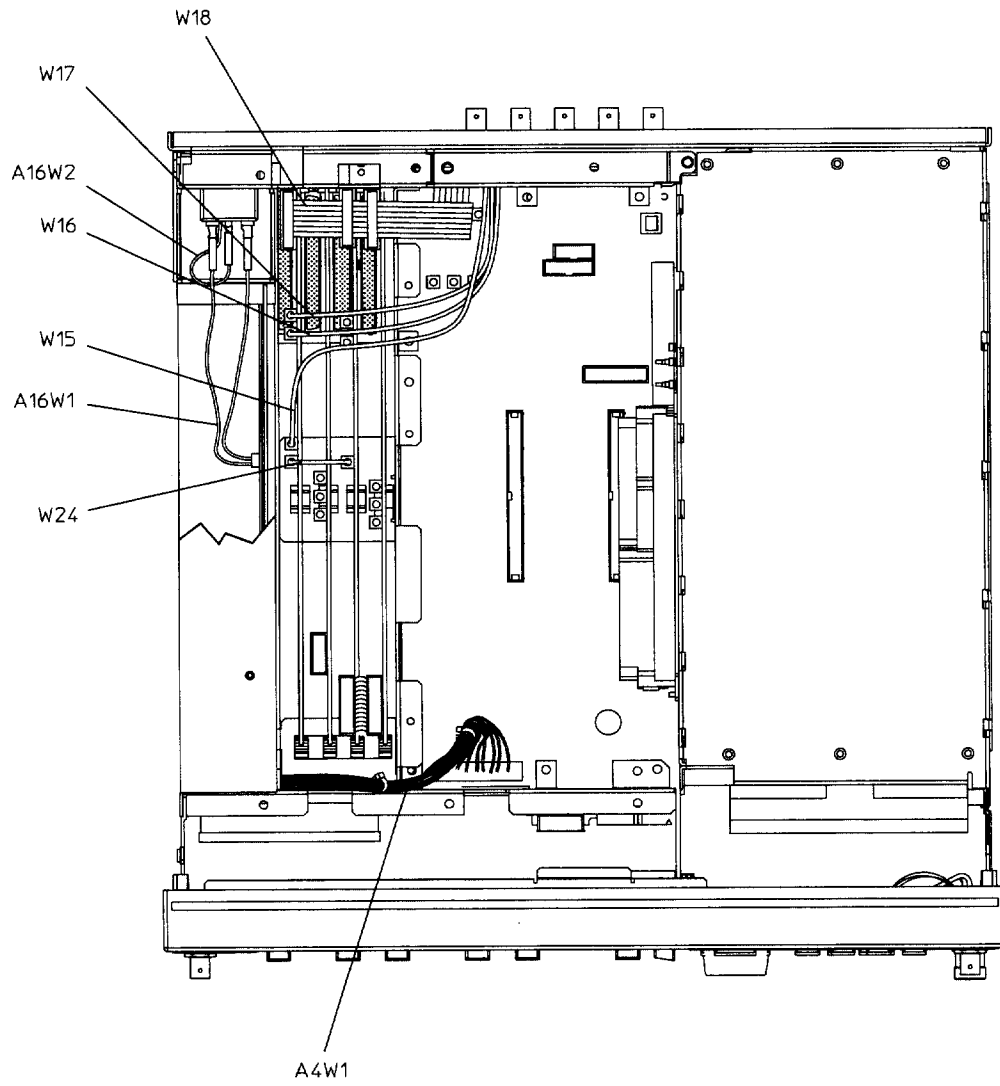

sk79b

Top View (ESG-DP Series - Options UN7, UN8 with 1EM)

Refer to Table 4-8 and Figure 4-8.

Table 4-8 Top View (ESG-DP Series - Options UN7, UN8 with 1EM)

Reference Designator	Part Number	Qty	Description
A4W1 ¹	(part of A4)	1	Power Supply (A4) to CPU/Motherboard (A14J6)
A16W1 ¹	(part of A16)	1	Line Module (A16) to Power Supply (A4J1)
A16W2 ¹	(part of A16)	1	Line Module (A16) to Chassis Ground Post on Rear Panel
A18W1 ¹	(part of A18)	1	BERT Rear Panel Interface Board (A18) to BERT (A6) (Option UN7)
W3	8120-5556	1	DATA to Data Generator (A8J2) (Option UN8)
W4	8120-5556	1	DATA CLOCK to Data Generator (A8J1) (Option UN8)
W5	8120-5556	1	SYMBOL SYNC to Data Generator (A8J3) (Option UN8)
W15	8120-5055	1	Baseband Generator (A7P403) to BASEBAND GENREF IN (Option UN8)
W16	8120-5055	1	Baseband Generator (A7P404) to Q OUT (Option UN8)
W17	8120-5055	1	Baseband Generator (A7P405) to I OUT (Option UN8)
W18	8120-8457	1	Rear Panel Interface Board (A17) to Data Generator (A8P2) and Baseband Generator (A7P2) (Option UN8 - connects in three places)
W19	8120-8349	1	Baseband Generator (A7P300) to Data Generator (A8P3) (Option UN8)
W21	8120-5556	1	Bit Error Rate Test Board (A6) to BER GATE IN (Option UN7)
W22	8120-5556	1	Bit Error Rate Test Board (A6) to BER CLK IN (Option UN7)
W23	8120-5556	1	Bit Error Rate Test Board (A6) to BER DATA IN (Option UN7)
W27	8120-8725	1	16-Pin Ribbon Cable, Parallel Data In, Data Generator (A8) to Baseband Generator (A7)

1. This cable is not replaceable by itself. You must order the corresponding assembly.

Figure 4-8 Top View (ESG-DP Series - Options UN7, UN8 with EM)

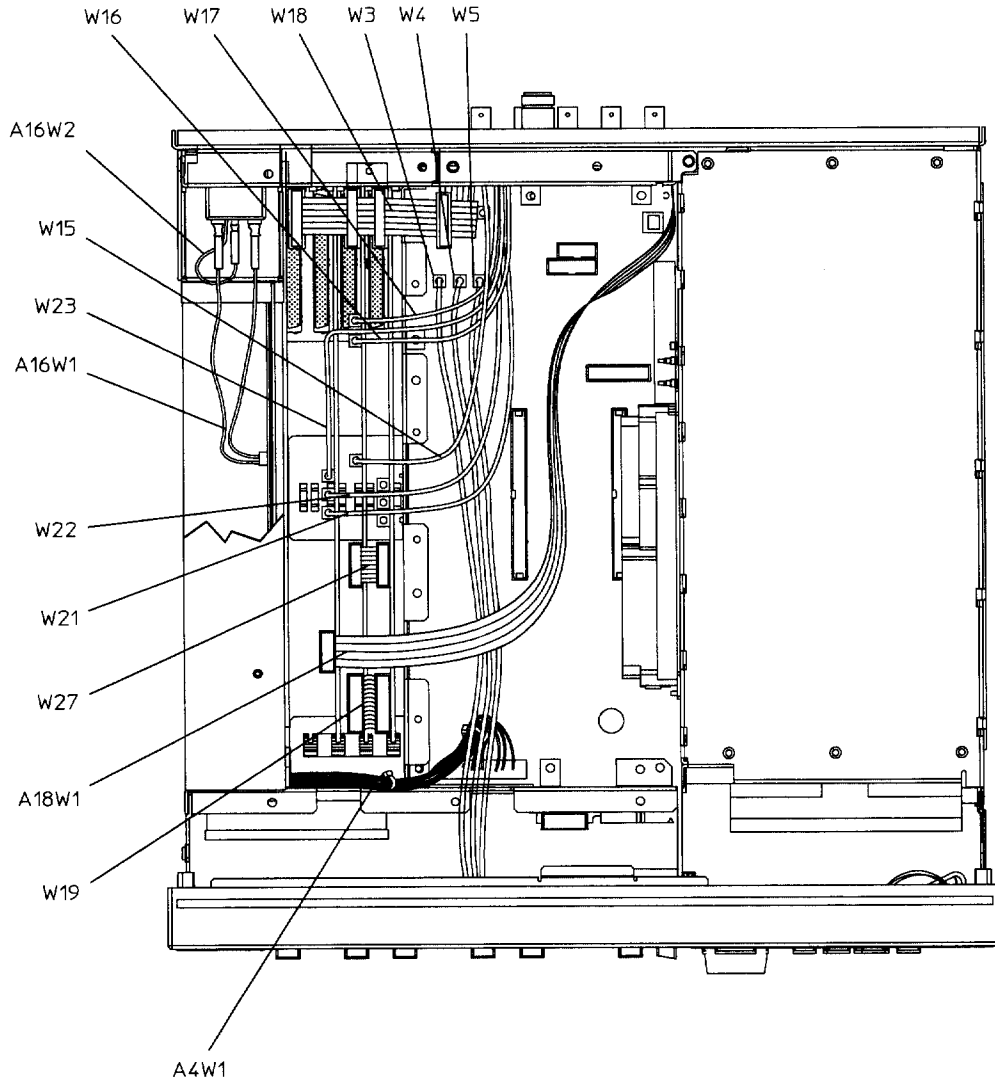

sk7116b

Top View (ESG-DP Series - Options UN7, UN8, UND)

Refer to Table 4-9 and Figure 4-9.

Table 4-9 Top View (ESG-D Series - Options UN7, UN8, UND)

Reference Designator	Part Number	Qty	Description
A4W1 ¹	(part of A4)	1	Power Supply (A4) to CPU/Motherboard (A14J6)
A16W1 ¹	(part of A16)	1	Line Module (A16) to Power Supply (A4J1)
A16W2 ¹	(part of A16)	1	Line Module (A16) to Chassis Ground Post on Rear Panel
A18W1 ¹	(part of A18)	1	BERT Rear Panel Interface Board (A18) to BERT (A6) (Option UN7)
W3	8120-5556	1	DATA to Data Generator (A8J2) (Option UN8)
W4	8120-5556	1	DATA CLOCK to Data Generator (A8J1) (Option UN8)
W5	8120-5556	1	SYMBOL SYNC to Data Generator (A8J3) (Option UN8)
W15	8120-5055	1	Baseband Generator (A7P403) to BASEBAND GENREF IN (Option UN8)
W16	8120-5055	1	Baseband Generator (A7P404) to Q OUT (Option UN8)
W17	8120-5055	1	Baseband Generator (A7P405) to I OUT (Option UN8)
W18	8120-8457	1	Rear Panel Interface Board (A17) to Data Generator (A8P2) and Baseband Generator (A7P2) (Option UN8 - connects in three places)
W19	8120-8349	1	Baseband Generator (A7P300) to Data Generator (A8P3) (Option UN8)
W21	8120-5556	1	Bit Error Rate Test Board (A6) to BER GATE IN (Option UN7)
W22	8120-5556	1	Bit Error Rate Test Board (A6) to BER CLK IN (Option UN7)
W23	8120-5556	1	Bit Error Rate Test Board (A6) to BER DATA IN (Option UN7)
W24	E4400-20131	1	Baseband Generator-13 MHz (A7) to Dual Arb Waveform Generator - 13 MHz (A5) (Option UN3 or UN4)
W25	8120-8748	1	Motherboard (A14P103) to Daughterboard - Q INT (A15J8)
W26	8120-8748	1	Motherboard (A14P102) to Daughterboard - I INT (A15J9)
W27	8120-8725	1	16-Pin Ribbon Cable, Parallel Data In, Data Generator (A8) to Baseband Generator (A7)

1. This cable is not replaceable by itself. You must order the corresponding assembly.

Figure 4-9 Top View (ESG-DP Series - Options UN7, UN8, UND)

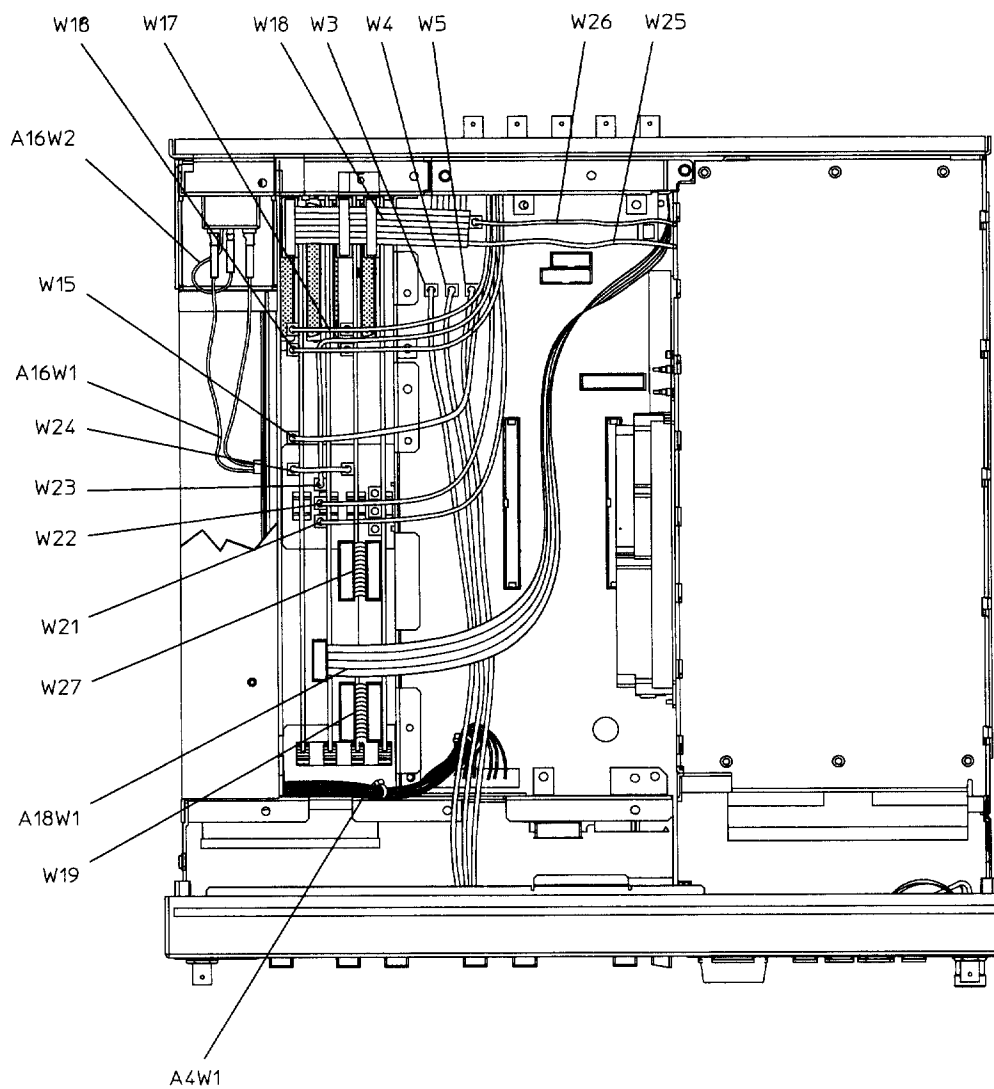

sk7160b

Top View (ESG-DP Series - Option UND with 1EM)

Refer to Table 4-10 and Figure 4-10.

Table 4-10 Top View (ESG-DP Series - Option UND with 1EM)

Reference Designator	Part Number	Qty	Description
A4W1 ¹	(part of A4)	1	Power Supply (A4) to CPU/Motherboard (A14J6)
A16W1 ¹	(part of A16)	1	Line Module (A16) to Power Supply (A4J1)
A16W2 ¹	(part of A16)	1	Line Module (A16) to Chassis Ground Post on Rear Panel
W15	8120-5055	1	Dual Arb Waveform Generator (A5) to BASEBAND GENREF IN
W16	8120-5055	1	Dual Arb Waveform Generator (A5) to Q OUT
W17	8120-5055	1	Dual Arb Waveform Generator (A5) to I OUT
W18	8120-8458	1	Rear Panel Interface Board (A7) to Dual Arb Waveform Generator (A5)
W18	8120-8457	1	Rear Panel Interface Board (A17) to Data Generator (A8P2), Baseband Generator (A7P2), and Dual Arb Waveform Generator (A5) (Option UN8 - connects in four places)

1. This cable is not replaceable by itself. You must order the corresponding assembly.

Figure 4-10 Top View (ESG-DP Series - Option UND with 1EM)

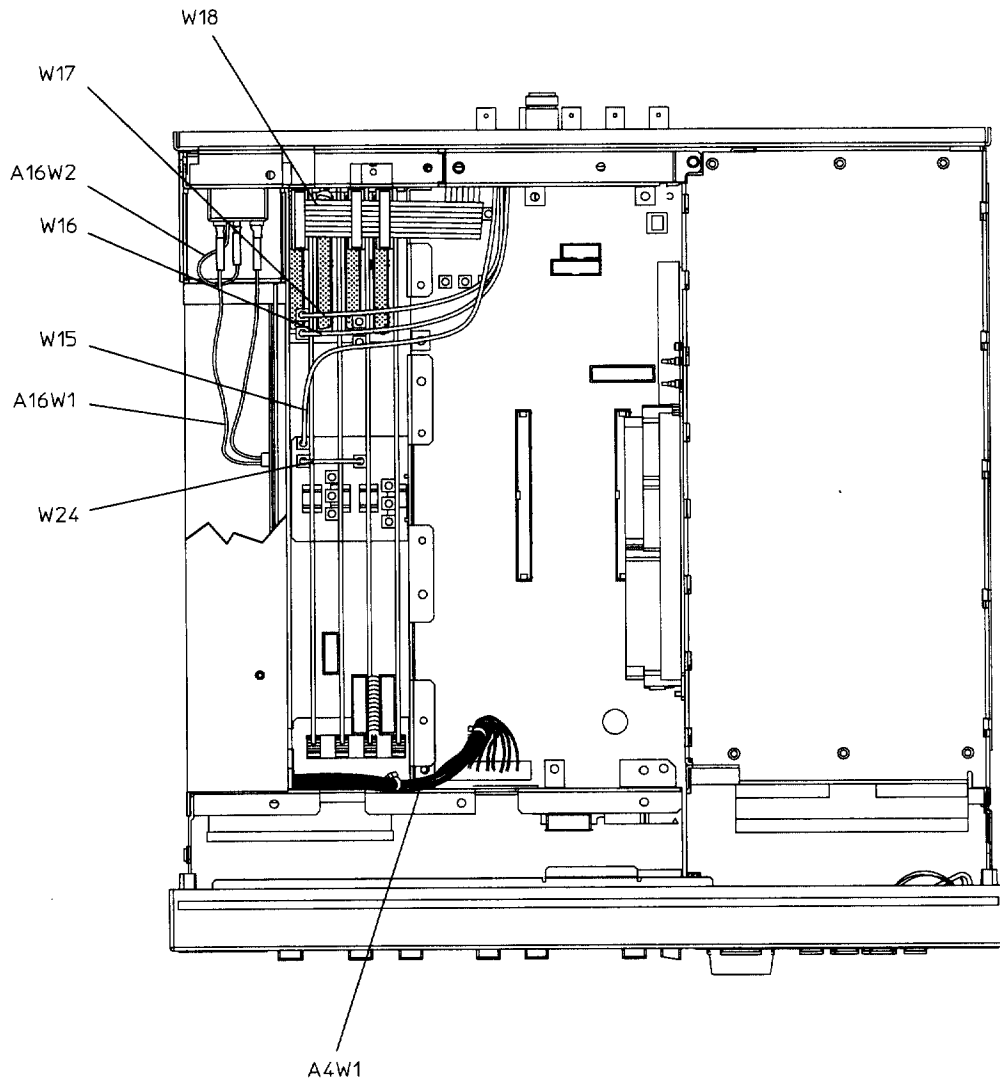

sk711b

Cables

Side View — YIG Driver Assembly

Refer to Table 4-11 and Figure 4-11.

Table 4-11 Side View — YIG Driver Assembly

Reference Designator	Part Number	Qty	Description
A22	E4423-60024	1	YIG Output Loop Assembly
W35	8120-8789	1	Ribbon Cable, YIG Driver (A22) to Motherboard (A14, J26)
W36	8120-8784	1	Flexible Cable, Daughterboard (A15, YTO FM) to YIG Driver (A22)
W37	8120-8784	1	Flexible Cable, Daughterboard (A15, PH Lock) to YIG Driver (A22)
W38	8120-8788	1	Ribbon Cable, YIG Driver (A22) to YIG Driver Oscillator Assembly (part of A22)
W39	E4423-20010	1	Semi-Rigid Cable, YIG Driver (A22) to Sampler (A23)
W40	E4423-20009	1	Semi-Rigid Cable, YIG Driver (A22) to Frac-N/Divider (A24)
W41	E4423-20013	1	Semi-Rigid Cable, YIG to YIG Driver (A22, Osc Assy)

Figure 4-11 Side View — YIG Driver Assembly

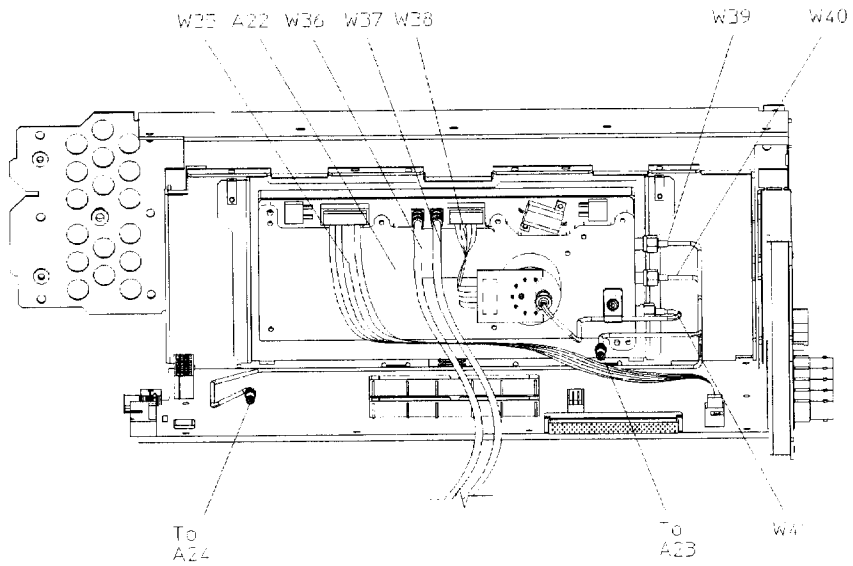

sk7107E

Inside Front Panel View

Refer to Table 4-12 and Figure 4-12.

Table 4-12 Inside Front Panel View

Reference Designator	Part Number	Qty	Description
A1W1 ¹	(part of A1)	1	Front Panel Board (A1) to CPU/Motherboard (A14J20)
A2DS1W1 ¹	(part of A2DS1)	1	Florescent Lamp (A2DS1) to A3W2
A3W1 ¹	(part of A3)	1	Inverter (A3) to CPU/Motherboard (A14J19)
A3W2 ¹	(part of A3)	1	Inverter (A3) to A2DS1W1
B1W1 ¹	(part of B1)	1	Small Fan (B1) to CPU/Motherboard (A14J16)
B2W1 ¹	(part of B2)	1	Large Fan (B2) to CPU/Motherboard (A14J17)
W1	8120-8786	1	I IN to Daughterboard (A15J2)
W2	8120-8786	1	Q IN to Daughterboard (A15J3)
W3	8120-5063	1	DATA to Baseband Generator (A7P100) (Options UN8)
W4	8120-5063	1	DATA CLOCK to Baseband Generator (A7P103) (Options UN8)
W5	8120-5063	1	SYMBOL SYNC to Baseband Generator (A7P101) (Options UN8)
W6	8120-8786	1	EXT 1 to Daughterboard (A15J4)
W7	8120-8786	1	EXT 2 to Daughterboard (A15J5)
W8	8120-8786	1	LF OUTPUT to Daughterboard (A15J6)
W9	E4400-20018	1	RF OUTPUT to Electronic Attenuator/RPP (AT1)
W9	E4400-20125	1	RF OUTPUT to RPP (AT1) (Option 1EM, UNB)
W10	8120-6759	1	Display (A2) to CPU/Motherboard (A14J21)
W47	8120-8783	1	Flexible Cable, PULSE IN (FP) to Pulse Modulator (A25) (not shown)

1. This cable is not replaceable by itself. You must order the corresponding assembly.

NOTE The figure on the adjacent page represents an ESG-DP series front panel having option UN8. On a standard ESG-DP series front panel, W3, W4, and W5 do not exist and the front panel connectors for W1 and W2 will be in a slightly different location. An ESG-AP series front panel does not include W1 through W5, but will include W47 with Option 1E6 (not shown). All models having Option 1EM do not have W1 through W9 on the front panel.

Figure 4-12 Inside Front Panel View

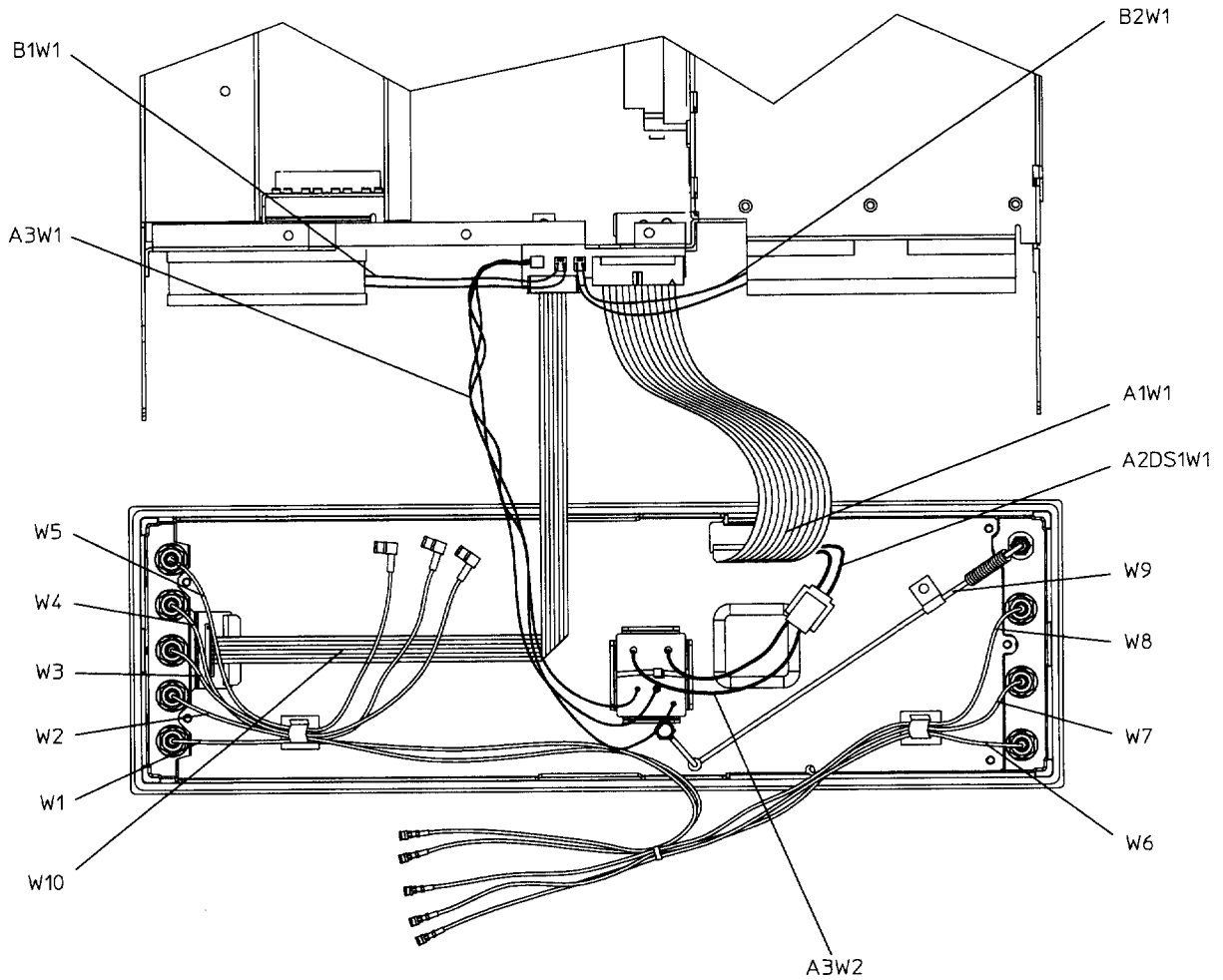

sk7146b

Electronic Attenuator/RPP View

Refer to Table 4-13 and Figure 4-13.

Table 4-13 Electronic Attenuator/RPP View

Reference Designator	Part Number	Qty	Description
W1	8120-8786	1	I IN to Daughterboard (A15J2)
W2	8120-8786	1	Q IN to Daughterboard (A15J3)
W6	8120-8786	1	EXT 1 to Daughterboard (A15J4)
W7	8120-8786	1	EXT 2 to Daughterboard (A15J5)
W8	8120-8786	1	LF OUTPUT to Daughterboard (A15J6)
W9	E4400-20018	1	RF OUTPUT to Electronic Attenuator/RPP (AT1)
W12	E4400-60060	1	Output Board (A9) to COHERENT CARRIER (includes cable retainer and ring)
W13	8120-6837	1	Electronic Attenuator/RPP (AT1) to CPU/Motherboard (A14J14)
W14	E4400-60061	1	Electronic Attenuator/RPP (AT1) to Output Board (A9) (includes cable retainer and ring)
W25	8120-8781	1	Motherboard (A14P103) to Daughterboard - Q INT (A15J8)
W26	8120-8781	1	Motherboard (A14P102) to Daughterboard - I INT (A15J9)
W36	8120-8784	1	Flexible Cable, Daughterboard (A15, YTO FM) to YIG Driver (A22)
W37	8120-8784	1	Flexible Cable, Daughterboard (A15, PH Lock) to YIG Driver (A22)
W40	E4423-20009	1	Semi-Rigid Cable, YIG Driver (A22) to Fractional-N (A24)
W42	E4423-20025	1	Semi-Rigid Cable, Sampler (A23) to Fractional-N (A24)
W43	E4423-10026	1	Semi-Rigid Cable, Sampler (A23) to Reference (A11)
W44	E4423-10024	1	Semi-Rigid Cable, Output (A9) to Fractional-N (A24)

Figure 4-13 Electronic Attenuator/RPP View

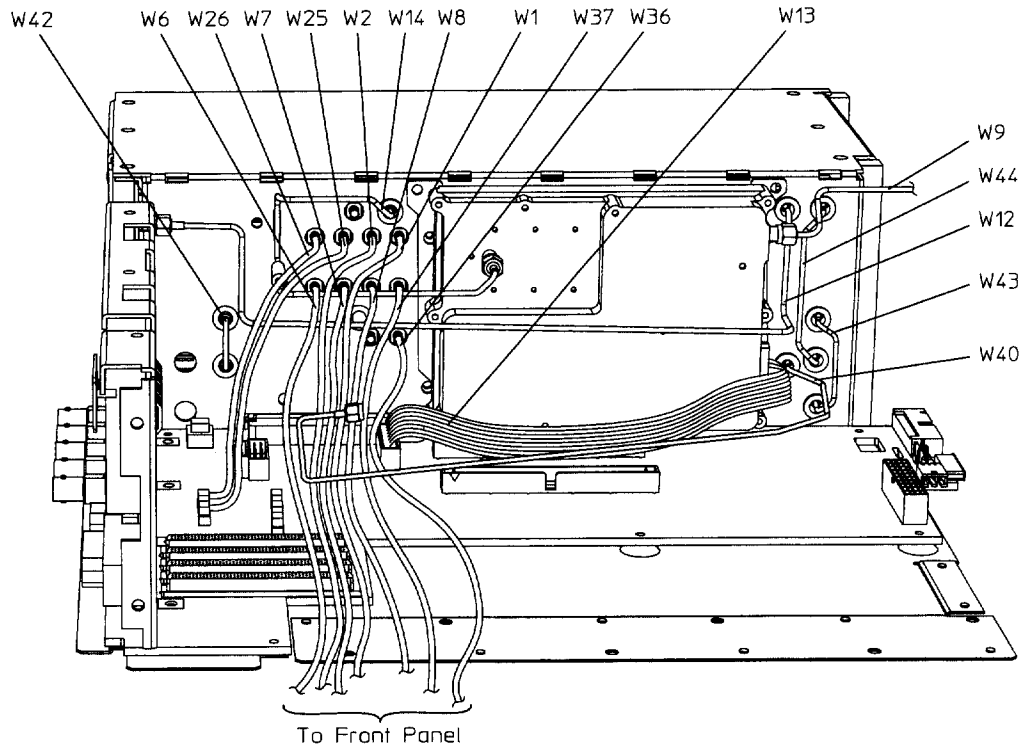

sk7126b

Electronic Attenuator/RPP View (with Option 1EM)

Refer to Table 4-14 and Figure 4-14.

Table 4-14 Electronic Attenuator/RPP View (with Option 1EM)

Reference Designator	Part Number	Qty	Description
W1	8120-8786	1	I IN to Daughterboard (A15J2)
W2	8120-8786	1	Q IN to Daughterboard (A15J3)
W6	8120-8786	1	EXT 1 to Daughterboard (A15J4)
W7	8120-8786	1	EXT 2 to Daughterboard (A15J5)
W8	8120-8786	1	LF OUTPUT to Daughterboard (A15J6)
W9	E4400-20025	1	RF OUTPUT to Electronic Attenuator/RPP (AT1)
W12	E4400-60060	1	Output Board (A9) to COHERENT CARRIER (includes cable retainer and ring)
W13	8120-6837	1	Electronic Attenuator/RPP (AT1) to CPU/Motherboard (A14J14)
W14	E4400-60061	1	Electronic Attenuator/RPP (AT1) to Output Board (A9) (includes cable retainer and ring)
W25	8120-8781	1	Motherboard (A14P103) to Daughterboard - Q INT (A15J8)
W26	8120-8781	1	Motherboard (A14P102) to Daughterboard - I INT (A15J9)
W36	8120-8784	1	Flexible Cable, Daughterboard (A15, YTO FM) to YIG Driver (A22)
W37	8120-8784	1	Flexible Cable, Daughterboard (A15, PH Lock) to YIG Driver (A22)
W40	E4423-20009	1	Semi-Rigid Cable, YIG Driver (A22) to Fractional-N (A24)
W42	E4423-20025	1	Semi-Rigid Cable, Sampler (A23) to Fractional-N (A24)
W43	E4423-10026	1	Semi-Rigid Cable, Sampler (A23) to Reference (A11)
W44	E4423-10024	1	Semi-Rigid Cable, Output (A9) to Fractional-N (A24)

Figure 4-14 Electronic Attenuator/RPP View (with Option 1EM)

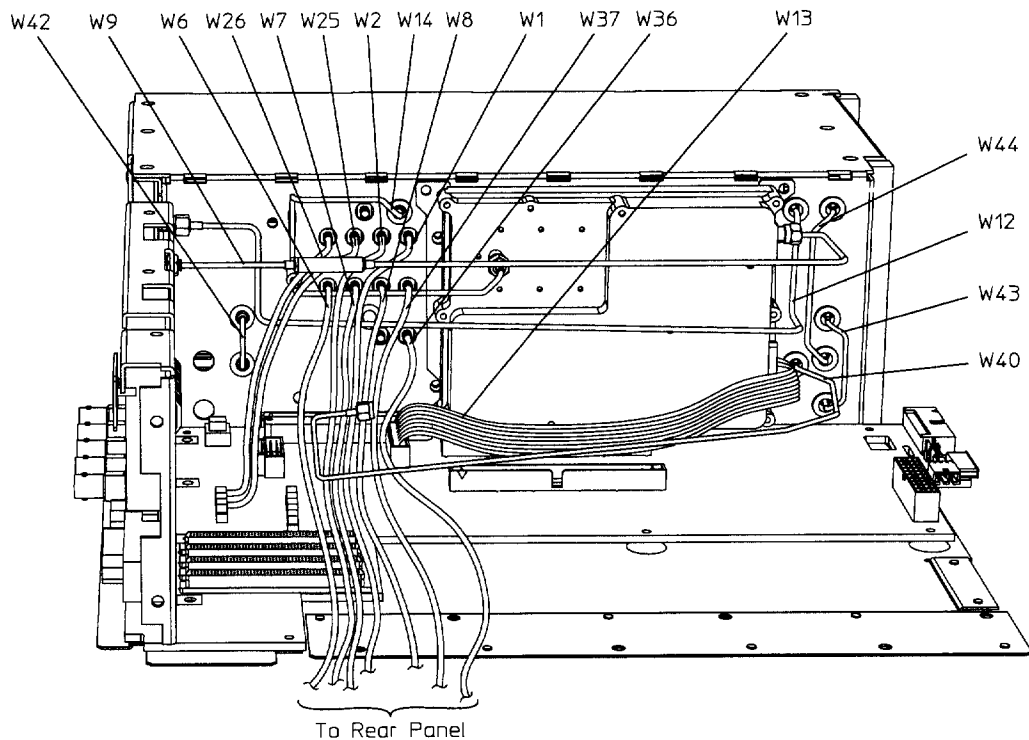

sk7143b

Mechanical Attenuator View (Option UNB)

Refer to Table 4-15 and Figure 4-15.

Table 4-15 Mechanical Attenuator View (Option UNB)

Reference Designator	Part Number	Qty	Description
A19W1 ¹	(part of A19)	1	RPP (A19) to Motherboard (A14J15)
W1	8120-8786	1	I IN to Daughterboard (A15J2)
W2	8120-8786	1	Q IN to Daughterboard (A15J3)
W6	8120-8786	1	EXT 1 to Daughterboard (A15J4)
W7	8120-8786	1	EXT 2 to Daughterboard (A15J5)
W8	8120-8786	1	LF OUTPUT to Daughterboard (A15J6)
W9	E4400-20125	1	RF OUTPUT to RPP (A19)
W12	E4400-60060	1	Output Board (A9) to COHERENT CARRIER (includes cable retainer and ring)
W13	E4400-20132	1	Mechanical Attenuator (AT1) to CPU/Motherboard (A14J14)
W14	E4400-60177	1	Mechanical Attenuator (AT1) to Output Board (A9) (includes cable retainer and ring)
W20	E4400-20126	1	Semi-Rigid Cable, Mechanical Attenuator (AT1) to RPP (A19)
W25	8120-8781	1	Motherboard (A14P103) to Daughterboard - Q INT (A15J8)
W26	8120-8781	1	Motherboard (A14P102) to Daughterboard - I INT (A15J9)
W36	8120-8784	1	Flexible Cable, Daughterboard (A15, YTO FM) to YIG Driver (A22)
W37	8120-8784	1	Flexible Cable, Daughterboard (A15, PH Lock) to YIG Driver (A22)
W40	E4423-20009	1	Semi-Rigid Cable, YIG Driver (A22) to Fractional-N (A24)
W42	E4423-20025	1	Semi-Rigid Cable, Sampler (A23) to Fractional-N (A24)
W43	E4423-10026	1	Semi-Rigid Cable, Sampler (A23) to Reference (A11)
W44	E4423-10024	1	Semi-Rigid Cable, Output (A9) to Fractional-N (A24)

1. This cable is not replaceable by itself. You must order the corresponding assembly.

Figure 4-15 Mechanical Attenuator View (Option UNB)

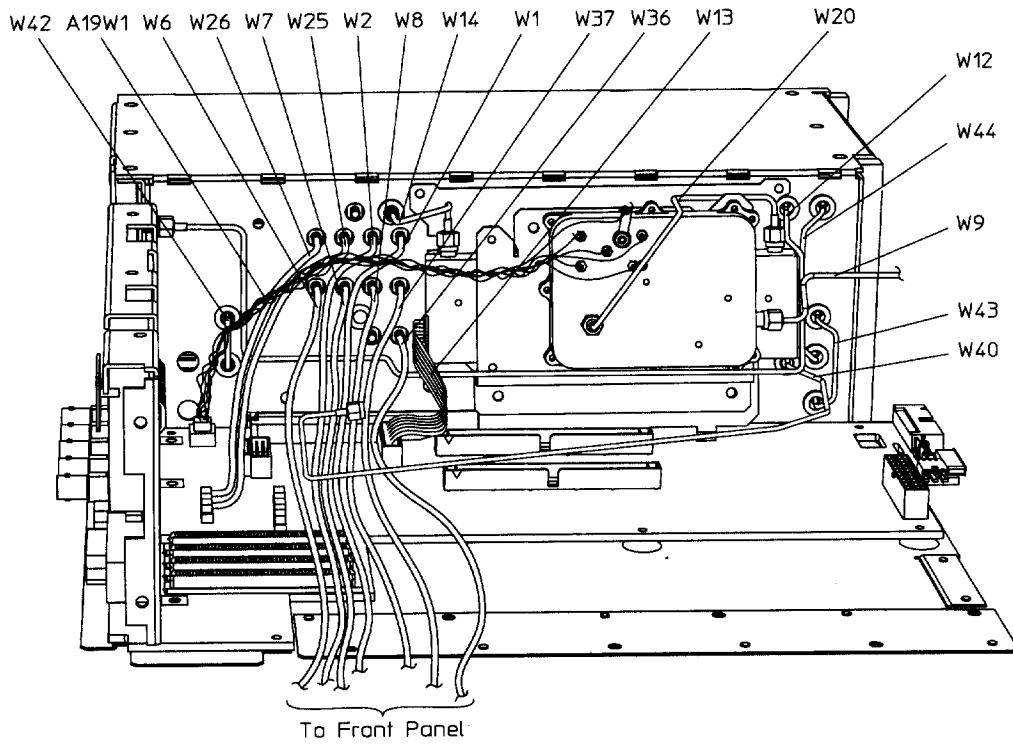

sk7144b

Mechanical Attenuator View (Option UNB with 1EM)

Refer to Table 4-16 and Figure 4-16.

Table 4-16 Mechanical Attenuator View (Option UNB with 1EM)

Reference Designator	Part Number	Qty	Description
A19W1 ¹	(part of A19)	1	RPP (A19) to Motherboard (A14J15)
W1	8120-8786	1	I IN to Daughterboard (A15J2)
W2	8120-8786	1	Q IN to Daughterboard (A15J3)
W6	8120-8786	1	EXT 1 to Daughterboard (A15J4)
W7	8120-8786	1	EXT 2 to Daughterboard (A15J5)
W8	8120-8786	1	LF OUTPUT to Daughterboard (A15J6)
W9	E4423-20012	1	RF OUTPUT to RPP (A19)
W12	E4400-60060	1	Output Board (A9) to COHERENT CARRIER (includes cable retainer and ring)
W13	E4400-20132	1	Mechanical Attenuator (AT1) to CPU/Motherboard (A14J14)
W14	E4400-60177	1	Mechanical Attenuator (AT1) to Output Board (A9) (includes cable retainer and ring)
W20	E4400-20126	1	Semi-Rigid Cable, Mechanical Attenuator (AT1) to RPP (A19)
W25	8120-8781	1	Motherboard (A14P103) to Daughterboard - Q INT (A15J8)
W26	8120-8781	1	Motherboard (A14P102) to Daughterboard - I INT (A15J9)
W36	8120-8784	1	Flexible Cable, Daughterboard (A15, YTO FM) to YIG Driver (A22)
W37	8120-8784	1	Flexible Cable, Daughterboard (A15, PH Lock) to YIG Driver (A22)
W40	E4423-20009	1	Semi-Rigid Cable, YIG Driver (A22) to Fractional-N (A24)
W42	E4423-20025	1	Semi-Rigid Cable, Sampler (A23) to Fractional-N (A24)
W43	E4423-10026	1	Semi-Rigid Cable, Sampler (A23) to Reference (A11)
W44	E4423-10024	1	Semi-Rigid Cable, Output (A9) to Fractional-N (A24)

1. This cable is not replaceable by itself. You must order the corresponding assembly.

Figure 4-16 Mechanical Attenuator View (Option UNB with 1EM)

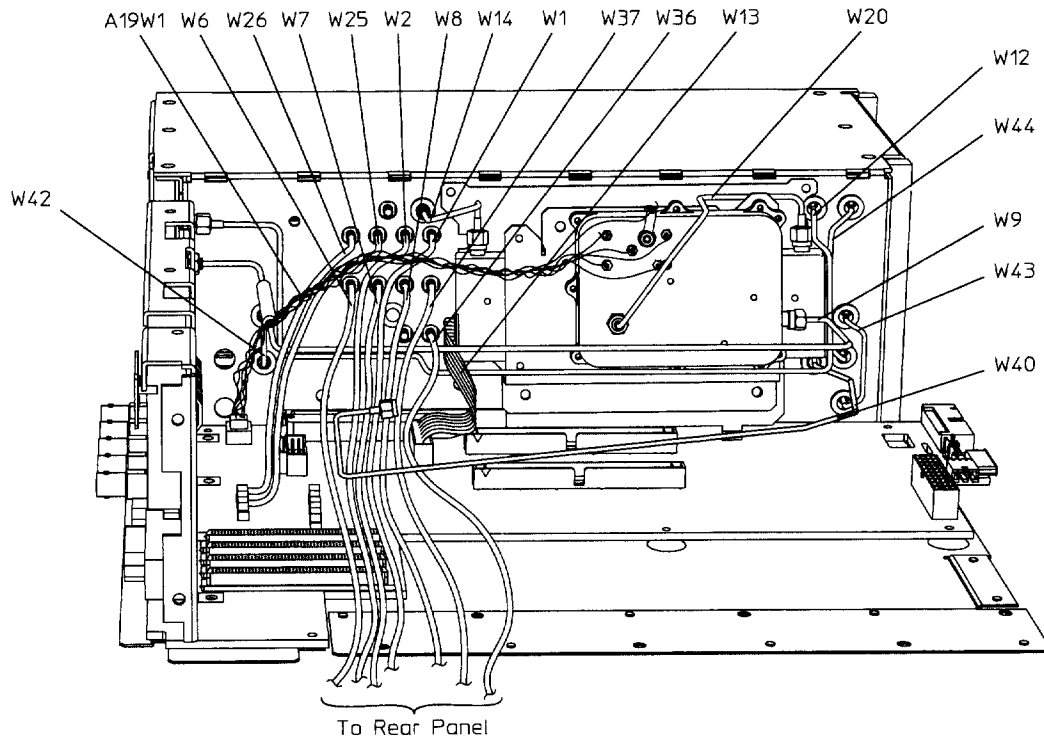

sk7145b

Pulse Modulator View (Option 1E6)

Refer to Table 4-17 and Figure 4-17.

Table 4-17 Pulse Modulator View (Option 1E6)

Reference Designator	Part Number	Qty	Description
A25W1	(part of A25)	1	Wire Harness, Pulse Modulator (A25) to Motherboard (A14)
W45	E4423-20017	1	Semi-Rigid Cable, Output (A9) to Pulse Modulator (A25)
W45	E4423-20012	1	Semi-Rigid Cable, Output (A9) to Pulse Modulator (A25) (Option UNB - not shown)
W46	E4423-20014	1	Semi-Rigid Cable, Electronic Attenuator (AT1) to Pulse Modulator (A25)
W46	E4423-20011		Semi-Rigid Cable, Mechanical Attenuator (AT1) to Pulse Modulator (A25) (Option UNB - not shown)
W47	8120-8783	1	Flexible Cable, PULSE IN (FP) to Pulse Modulator (A25)

Figure 4-17 Pulse Modulator View (Option 1E6)

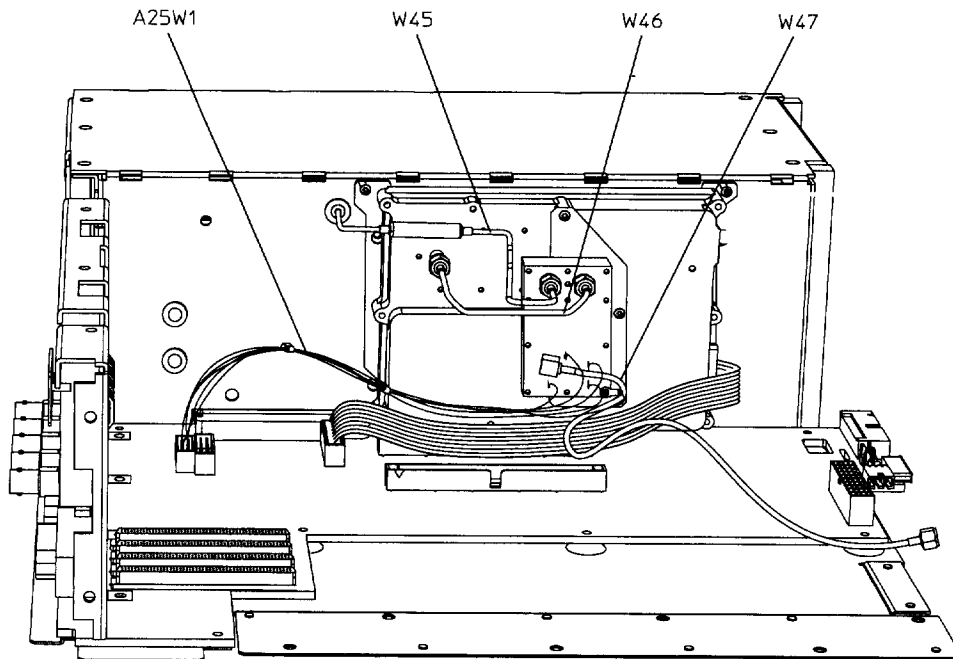

sk7139b

Hardware and Other Instrument Parts

This section lists part numbers for hardware and other parts in your signal generator. The following instrument views are provided to help you locate specific parts.

- “Top View” on page 4-40
- “YIG Driver View” on page 4-42
- “Disassembled Mechanical Attenuator View (Option UNB)” on page 4-43
- “Disassembled Pulse Modulator View (Option 1E6)” on page 4-44
- “Disassembled Pulse Modulator View (Option 1E6/UNB)” on page 4-45
- “Front Panel View (ESG-AP Series)” on page 4-46
- “Front Panel View (ESG-DP Series)” on page 4-48
- “Disassembled Front-Panel View” on page 4-50
- “Daughterboard Card Cage View” on page 4-52
- “Inside Rear-Panel View” on page 4-53
- “Rear-Panel View (ESG-AP Series)” on page 4-54
- “Rear-Panel View (ESG-AP Series - Option 1EM)” on page 4-55
- “Rear-Panel View (ESG-DP Series)” on page 4-56
- “Rear Panel View (ESG-DP Series - Option 1EM)” on page 4-58
- “Instrument Chassis with Top and Right-Side Hardware” on page 4-60
- “Power Supply Shield and Left-Side Hardware” on page 4-62
- “Motherboard and Bottom-Side Hardware” on page 4-63
- “Instrument Cover and Associated Parts” on page 4-64

Top View

Refer to Table 4-18 and Figure 4-18.

Table 4-18 Top View

Item No.	Part Number	Qty	Description
1	1400-0054	1	Clamp-Semi-Rigid Cable (W14)
2	0515-0372	1	Screw-Machine M3x8 CW-PN-TX
3	0515-0430	2	Screw-Machine M3x6 CW-PN-TX
4	0361-1341	4	Rivet-Plastic
5	0515-0374	4	Screw-Machine M3x10 CW-PN-TX
6	E4400-20041	1	Shield Cap
7	0400-0001	1	Grommet Round .562ID
8	0515-1521	2	Screw-Machine M3x5 FL-TX
9	E4400-60221	1	A14Q501 Transistor Assembly
10	0515-0374	1	Screw-Machine M3x10 CW-PN-TX
11	0340-1162	1	Bushing, Insulator 0.119 ID
12	0340-0614	1	Insulator Pad, Transistor TO-220

Figure 4-18 Top View

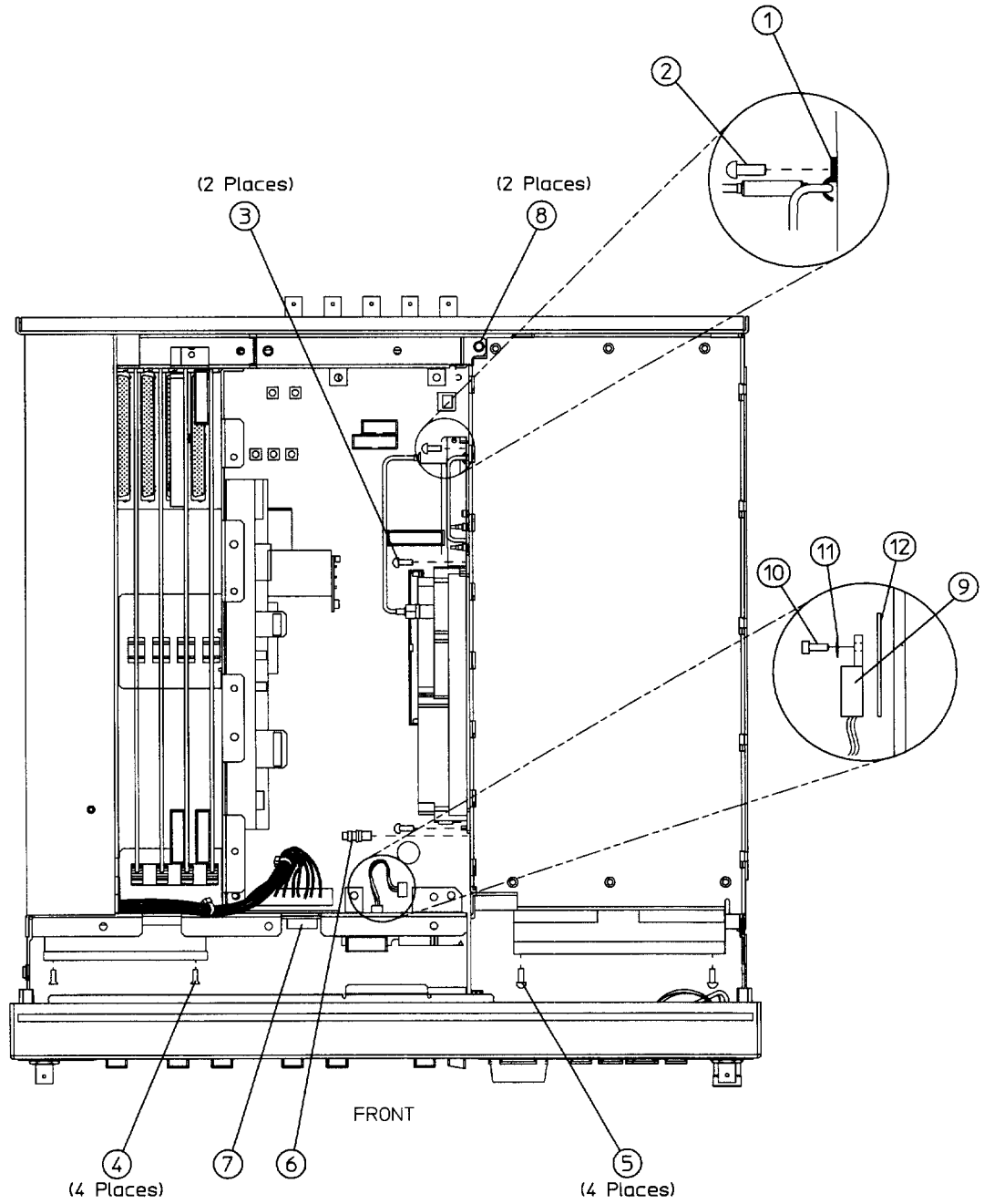

sk7123b

YIG Driver View

Refer to Table 4-19 and Figure 4-19.

Table 4-19 YIG Driver View

Item No.	Part Number	Qty	Description
1	0515-0372	2	Screw-Machine M3x8 CW-PN-TX
2	0515-0372	1	Screw-Machine M3x8 CW-PN-TX
3	1400-0054	1	Clamp-Semi-Rigid Cable

Figure 4-19 YIG Driver View

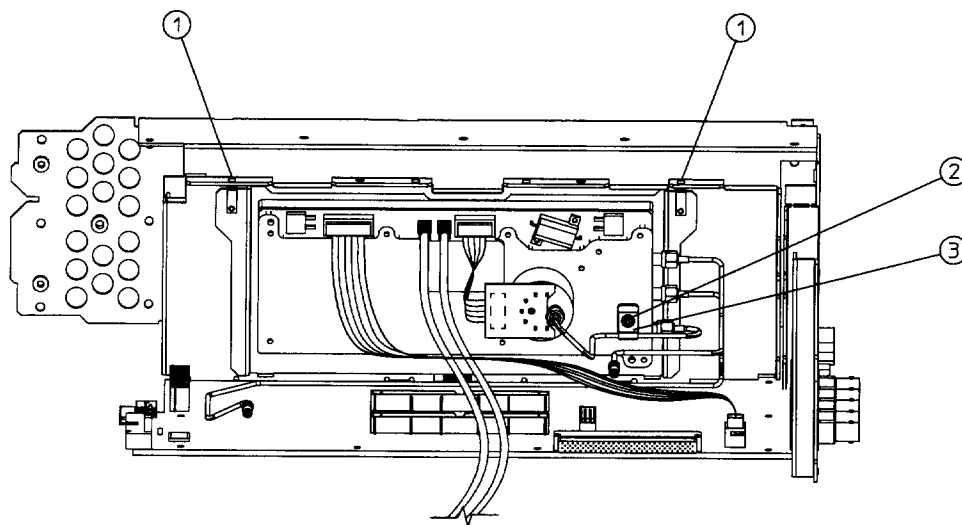

sk7151b

Disassembled Mechanical Attenuator View (Option UNB)

Refer to Table 4-20 and Figure 4-20.

Table 4-20 Disassembled Mechanical Attenuator View (Option UNB)

Item No.	Part Number	Qty	Description
1	E4400-00027	1	Bracket-RPP
2	0515-0664	3	Screw-Machine M3x12 CW-PN-TX
3	0515-0430	2	Screw-Machine M3x6 CW-PN-TX
4	E4400-00028	1	Bracket-Attenuator
5	0515-1102	6	Screw-Machine M3x8 FL-TX

Figure 4-20 Disassembled Mechanical Attenuator View (Option UNB)

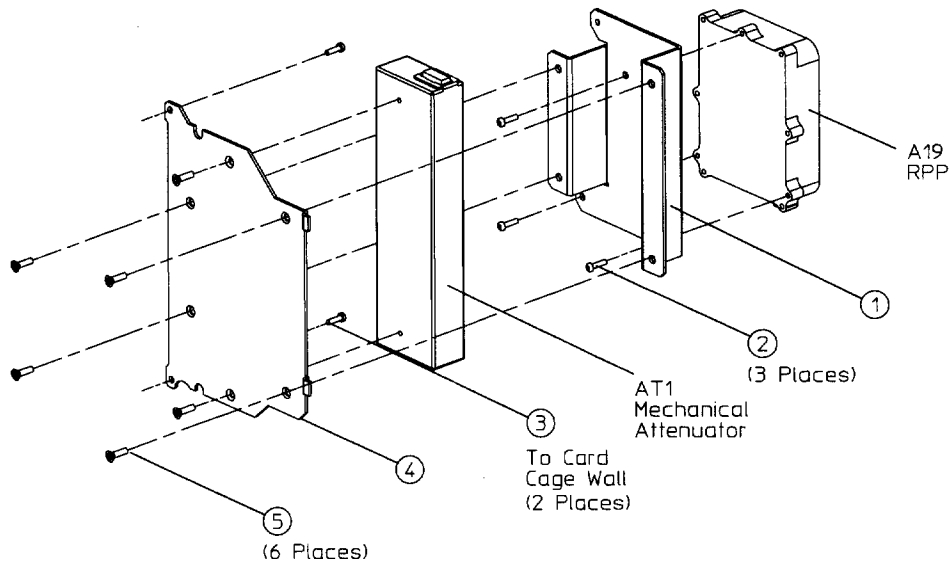

sk718b

Disassembled Pulse Modulator View (Option 1E6)

Refer to Table 4-21 and Figure 4-21.

Table 4-21 Disassembled Pulse Modulator View (Option 1E6)

Item No.	Part Number	Qty	Description
1	0515-0372	2	Screw-Machine M3x8 CW-PN-TX
2	E4423-00003	1	Bracket-Pulse Modulator
3	0515-2001	2	Screw-Machine M2.5x10 FL-TX

Figure 4-21 Disassembled Pulse Modulator View (Option 1E6)

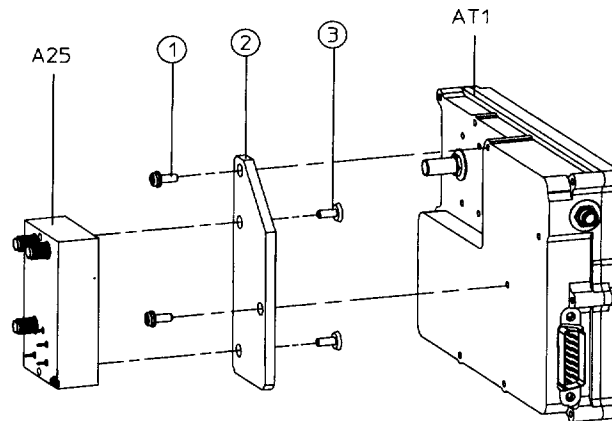

sk7152b

Disassembled Pulse Modulator View (Option 1E6/UNB)

Refer to Table 4-22 and Figure 4-22.

Table 4-22 Disassembled Pulse Modulator View (Option 1E6/UNB)

Item No.	Part Number	Qty	Description
1	E4400-00027	1	Bracket-RPP
2	0515-0664	3	Screw-Machine M3x12 CW-PN-TX
3	0515-0430	2	Screw-Machine M3x6 CW-PN-TX
4	E4400-00028	1	Bracket-Attenuator
5	0515-1102	6	Screw-Machine M3x8 FL-TX
6	0515-0367	2	Screw-Machine M2.5x8 CW-PN-TX

Figure 4-22 Disassembled Pulse Modulator View (Option 1E6/UNB)

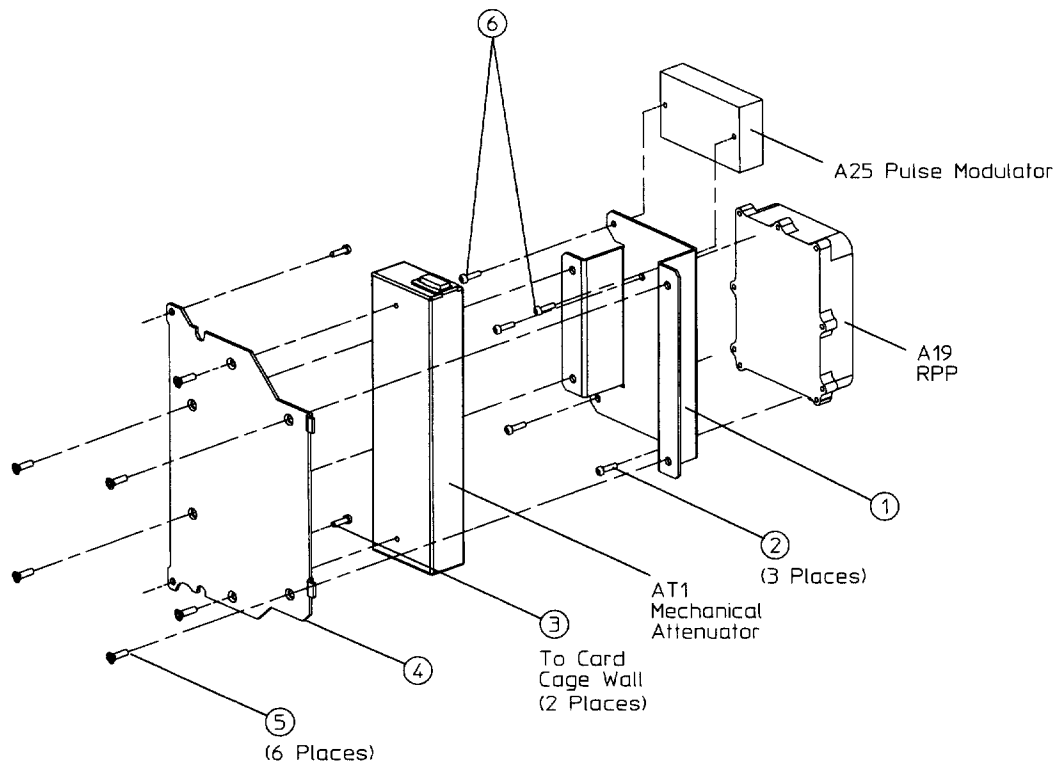

sk7149b

Front Panel View (ESG-AP Series)

Refer to Table 4-23 and Figure 4-23.

Table 4-23 Front Panel View (ESG-AP Series)

Item No.	Part Number	Qty	Description
1	E4400-80011	1	Label-Connectors
2	E4400-80072	1	Nameplate - E4423B 250k - 1GHz
2	E4400-80073	1	Nameplate - E4424B 250k - 2GHz
2	E4400-80074	1	Nameplate - E4425B 250k - 3GHz
2	E4400-80075	1	Nameplate - E4426B 250k - 4GHz
3	E4400-40003	1	Knob-RPG
4	E4400-80016	1	Label-Keypad
5	2950-0035	3	Nut-Hex 15/32-32
6	3050-1919	3	Washer-Wavy.490ID
7	E4400-80017	1	Label-Keypad (Option 1EM)
8	E4423-80001	1	Label-Connectors (Option 1E6)
9	2950-0035	4	Nut-Hex 15/32-32
10	3050-1919	4	Washer-Wavy.490ID

Figure 4-23 Front Panel View (ESG-AP Series)

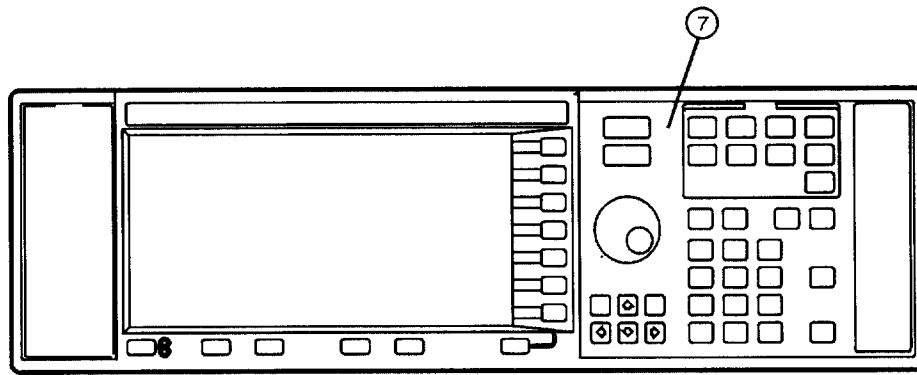
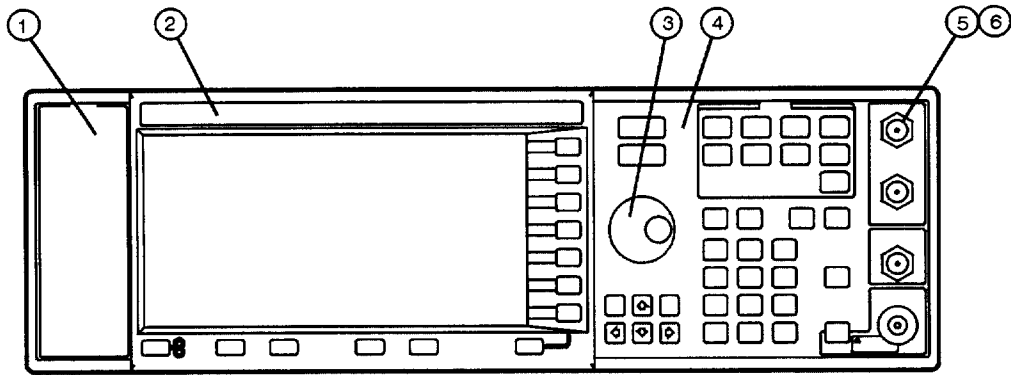

OPTION 1EM

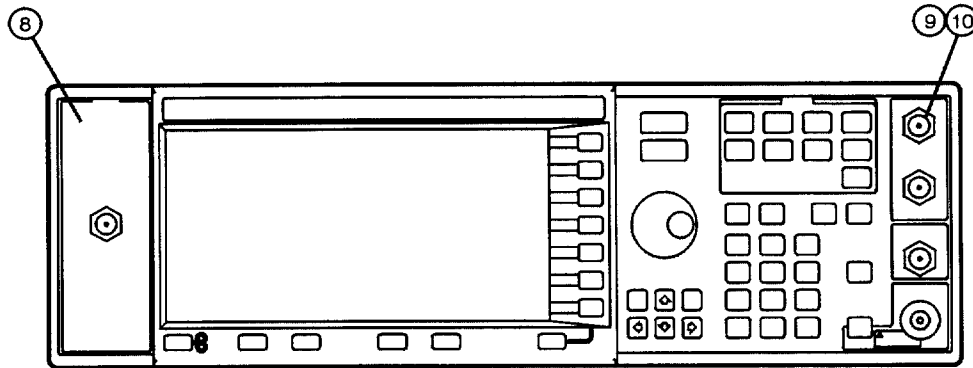

OPTION 1E6

sk799b

Front Panel View (ESG-DP Series)

Refer to Table 4-24 and Figure 4-24.

Table 4-24 Front Panel View (ESG-DP Series)

Item No.	Part Number	Qty	Description
1	E4400-80010	1	Label-Connectors
2	E4423-80003	1	Nameplate - E4434B 250k - 1GHz
2	E4423-80004	1	Nameplate - E4435B 250k - 2GHz
2	E4423-80005	1	Nameplate - E4436B 250k - 3GHz
2	E4423-80006	1	Nameplate - E4437B 250k - 4GHz
3	E4400-40003	1	Knob-RPG
4	E4400-80005	1	Label-Keypad
5	2950-0035	5	Nut-Hex 15/32-32
6	3050-1919	5	Washer-Wavy .490ID
7	E4400-80011	1	Label-Connectors (Option 1EM)
8	E4400-80015	1	Label-Keypad (Option 1EM)
9	E4400-80006	1	Label-Connectors (Options UN7, UN8, UND)
10	2950-0035	8	Nut-Hex 15/32-32 (Options UN7, UN8, UND)
11	3050-1919	8	Washer-Wavy .490ID (Options UN7, UN8, UND)

Figure 4-24 Front-Panel View (ESG-DP Series)

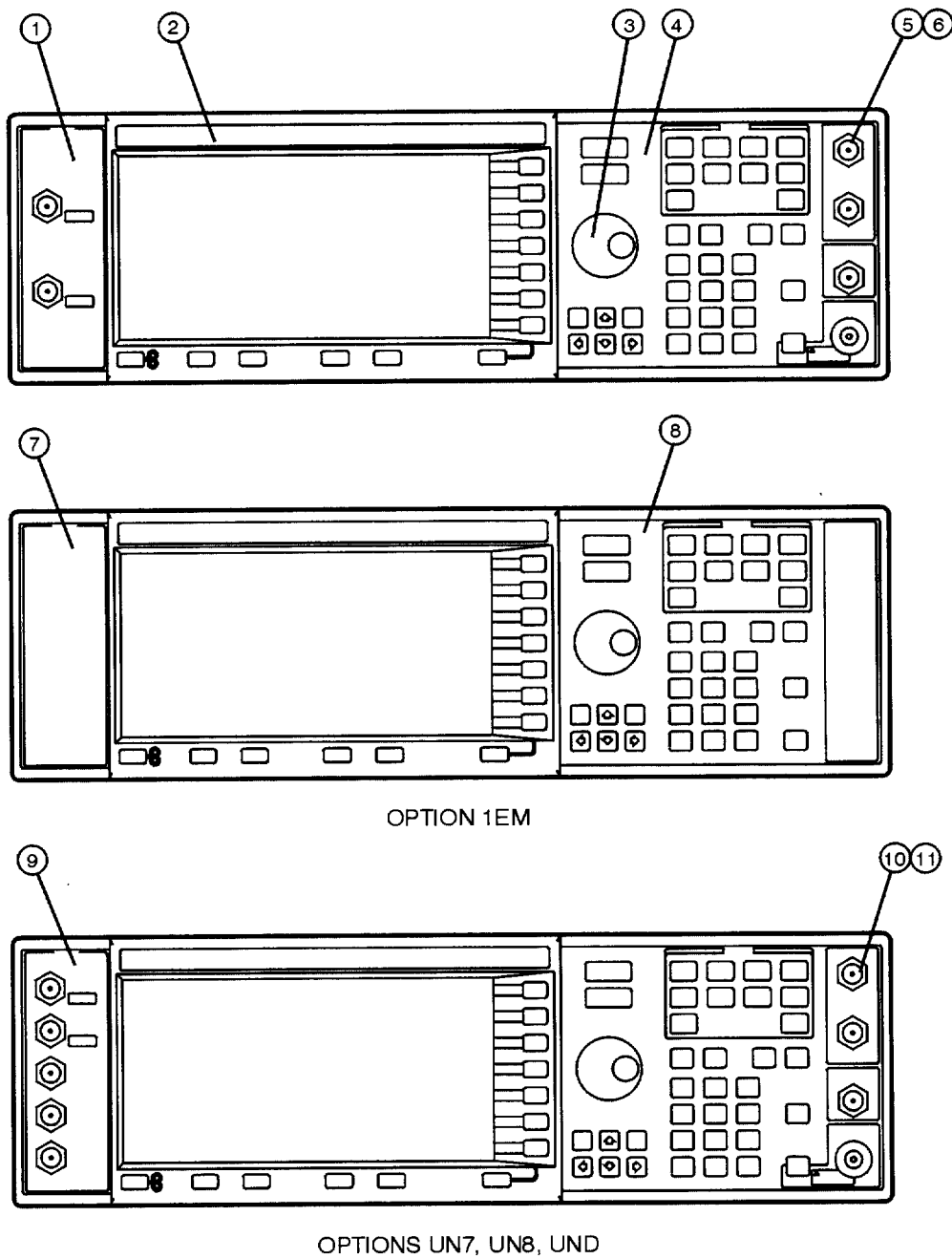

sk7158b

Disassembled Front-Panel View

Refer to Table 4-25 and Figure 4-25.

Table 4-25 Disassembled Front-Panel View

Item No.	Part Number	Qty	Description
1	1250-1811	1	Adapter-Female SMA to Female Type-N
2	E4400-20012	1	Frame-Front
3	3050-1935	1	Washer-Flat
4	2190-0383	1	Washer-Lock
5	2950-0054	1	Nut-Hex 1/2-28
6	E4400-40001	1	Rubber Keypad
7	0515-1521	5	Screw-Machine M3x5 FL-TX
8	0515-0372	4	Screw-Machine M3x8 CW-PN-TX
9	1400-1594	2 ¹	Clamp-Flexible Cables
10	0515-0372	8	Screw-Machine M3x8 CW-PN-TX
11	1400-0054	1	Clamp-Semi-Rigid Cable (W9)
12	1400-1533	1	Clamp-Ribbon Cable (A1W1)
13	1400-0493	1	Cable Tie Wrap
14	1400-0611	1	Clamp-Ribbon Cable (W10)
15	E4400-00008	1	Front Frame RFI Shield
16	E4400-00009	1	Filter Bracket
17	4330-1711	1	Glass Filter 70% XMT
18	E4400-40008	1	Light Pipe
19	8160-0723	2 Ft	Spiral Gasket-BC CY .094
20	8160-0660	4 Ft	RFI Round Mesh.125
21	0515-1227	9	Screw-Machine M3x6 FL-TX

1. ESG-AP Series uses a quantity of one.

Figure 4-25 Disassembled Front-Panel View

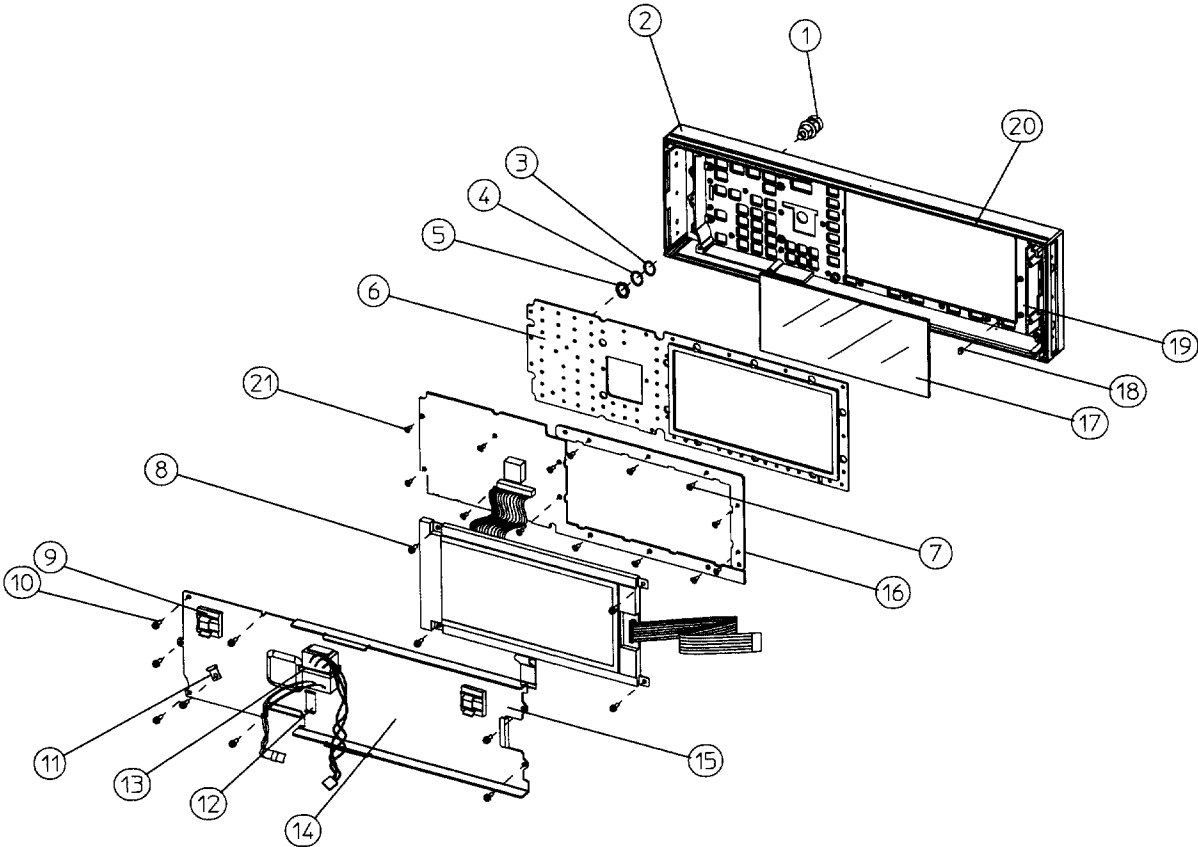

sk7148b

Daughterboard Card Cage View

Refer to Table 4-26 and Figure 4-26.

Table 4-26 Daughterboard Card Cage View

Item No.	Part Number	Qty	Description
1	E4400-40002	10	Retainer-Cable
2	0510-1643	10	Retainer Ring .309ID
3	0515-0430	5	Screw-Machine M3x6 CW-PN-TX

Figure 4-26 Daughterboard Card Cage View

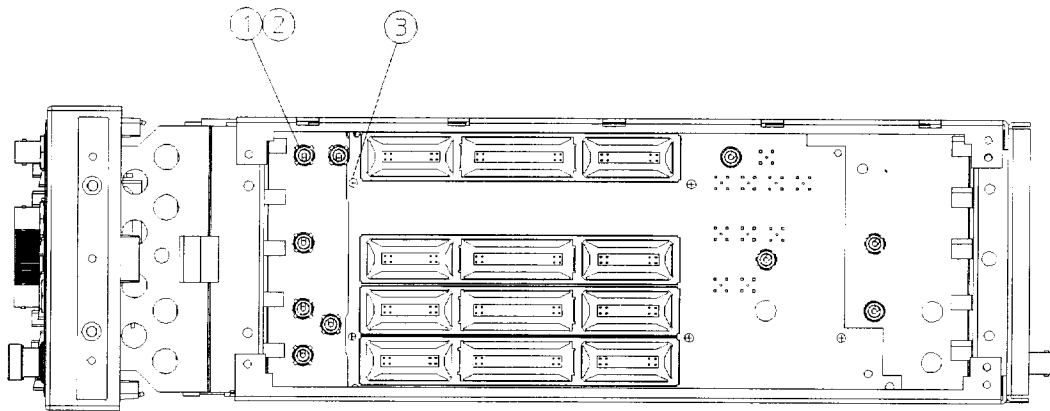

sk7124t

Inside Rear-Panel View

Refer to Table 4-27 and Figure 4-27.

Table 4-27 Inside Rear-Panel View

Item No.	Part Number	Qty	Description
1	0535-0031	2	Nut-Hex M3.0

Figure 4-27 Inside Rear-Panel View

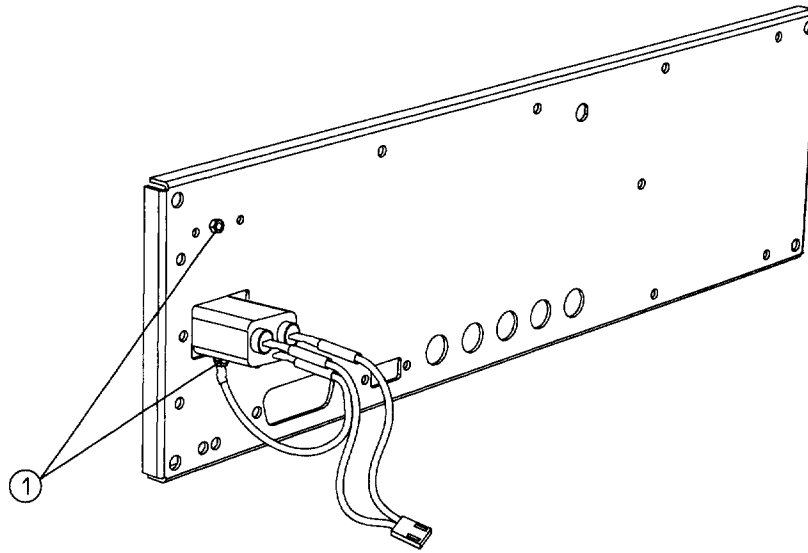

sk720b

Rear-Panel View (ESG-AP Series)

Refer to Table 4-28 and Figure 4-28.

Table 4-28 Rear-Panel View (ESG-AP Series)

Item No.	Part Number	Qty	Description
1	0515-0372	10	Screw-Machine M3x8 CW-PN-TX
2	E4400-00032	1	Panel-Rear
6	6960-0023	1	Plug-Hole .312D
7	E4400-00017	1	Serial Number Plate
8	0515-1102	2	Screw-Machine M3x8 FL-TX
9	0380-0644	2	Standoff-Hex .327L 6-32
10	2190-0577	2	Washer-Lock
11	0380-2079	2	Standoff-Hex .312L 4-40
12	2190-0003	2	Washer-Lock
14	2950-0054	5	Nut-Hex 1/2-28
15	2190-0068	5	Washer-Lock .505ID

Figure 4-28 Rear-Panel View (ESG-AP Series)

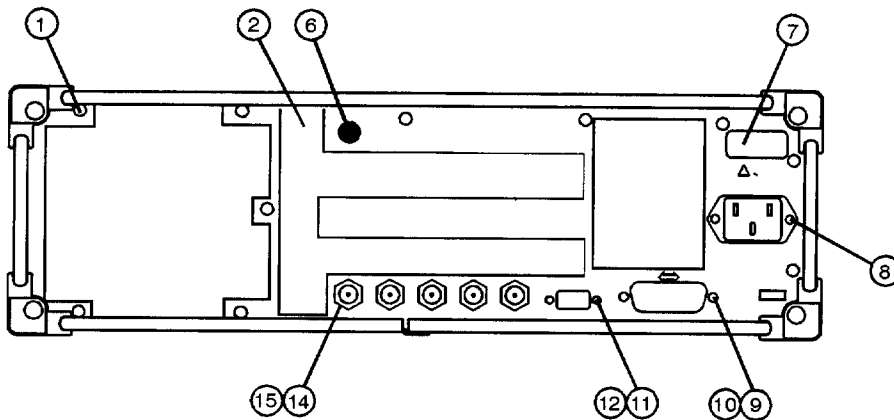

sk773a

Rear-Panel View (ESG-AP Series - Option 1EM)

Refer to Table 4-29 and Figure 4-29.

Table 4-29 Rear-Panel View (ESG-AP Series - Option 1EM)

Item No.	Part Number	Qty	Description
1	0515-0372	10	Screw-Machine M3x8 CW-PN-TX
2	E4400-00033	1	Panel-Rear
6	6960-0023	1	Plug-Hole .312D
7	2950-0035	3	Nut-Hex 15/32-32
8	2190-0102	3	Washer-Lock .472ID
9	08559-60002	1	RF Output Assy
10	2950-0132	1	Nut-Hex 7/16-28
11	2190-0102	1	Washer-Lock
12	6960-0002	1	Plug-Hole .500D
13	E4400-00017	1	Serial Number Plate
14	0515-1102	2	Screw-Machine M3x8 FL-TX
15	0380-0644	2	Standoff-Hex .327L 6-32
16	2190-0577	2	Washer-Lock
17	0380-2079	2	Standoff-Hex .312L 4-40
18	2190-0003	2	Washer-Lock
19	2950-0054	5	Nut-Hex 1/2-28
20	2190-0068	5	Washer-Lock .505ID

Figure 4-29 Rear-Panel View (ESG-AP Series - Option 1EM)

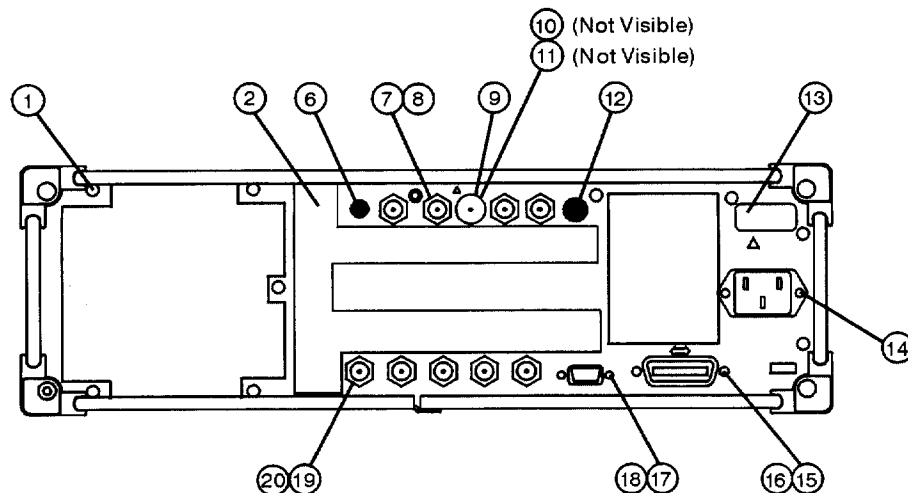

sk7100b

Rear-Panel View (ESG-DP Series)

Refer to Table 4-30 and Figure 4-30.

Table 4-30 Rear-Panel View (ESG-DP Series)

Item No.	Part Number	Qty	Description
1	0515-0372	10	Screw-Machine M3x8 CW-PN-TX
2	E4400-00032	1	Panel-Rear
3	0515-0372	1	Screw-Machine M3x8 CW-PN-TX (used to attach item 4))
4	1250-2759	1	Dust Cap Female SMA
5	1250-1753	1	Adapter-Female SMA to Female SMA
7	E4400-00017	1	Serial Number Plate
8	0515-1102	2	Screw-Machine M3x8 FL-TX
9	0380-0644	2	Standoff-Hex .327L 6-32
10	2190-0577	2	Washer-Lock
11	0380-2079	2	Standoff-Hex .312L 4-40
12	2190-0003	2	Washer-Lock
13	6960-0002	3	Plug-Hole .500D (Options UN8, UND)
14	2950-0054	5	Nut-Hex 1/2-28
15	2190-0068	5	Washer-Lock .505ID
16	2950-0035	11	Nut-Hex 15/32-32 (Options UN8, UND)
17	2190-0102	11	Washer-Lock .472ID (Options UN8, UND)
18	E4400-00031	1	Panel-Rear (Options UN8, UND)
19	2950-0035	14	Nut-Hex 15/32-32 (Option UN7)
20	2190-0102	14	Washer-Lock .472ID (Option UN7)
21	E4400-00025	1	Panel-Rear (Option UN7)
22	2950-0078	5	Nut-Hex 10-32 (for the SMBs) (Option UN7)
23	2190-0124	5	Washer-Lock .195ID (for the SMBs) (Option UN7)

Figure 4-30 Rear-Panel View (ESG-DP Series)

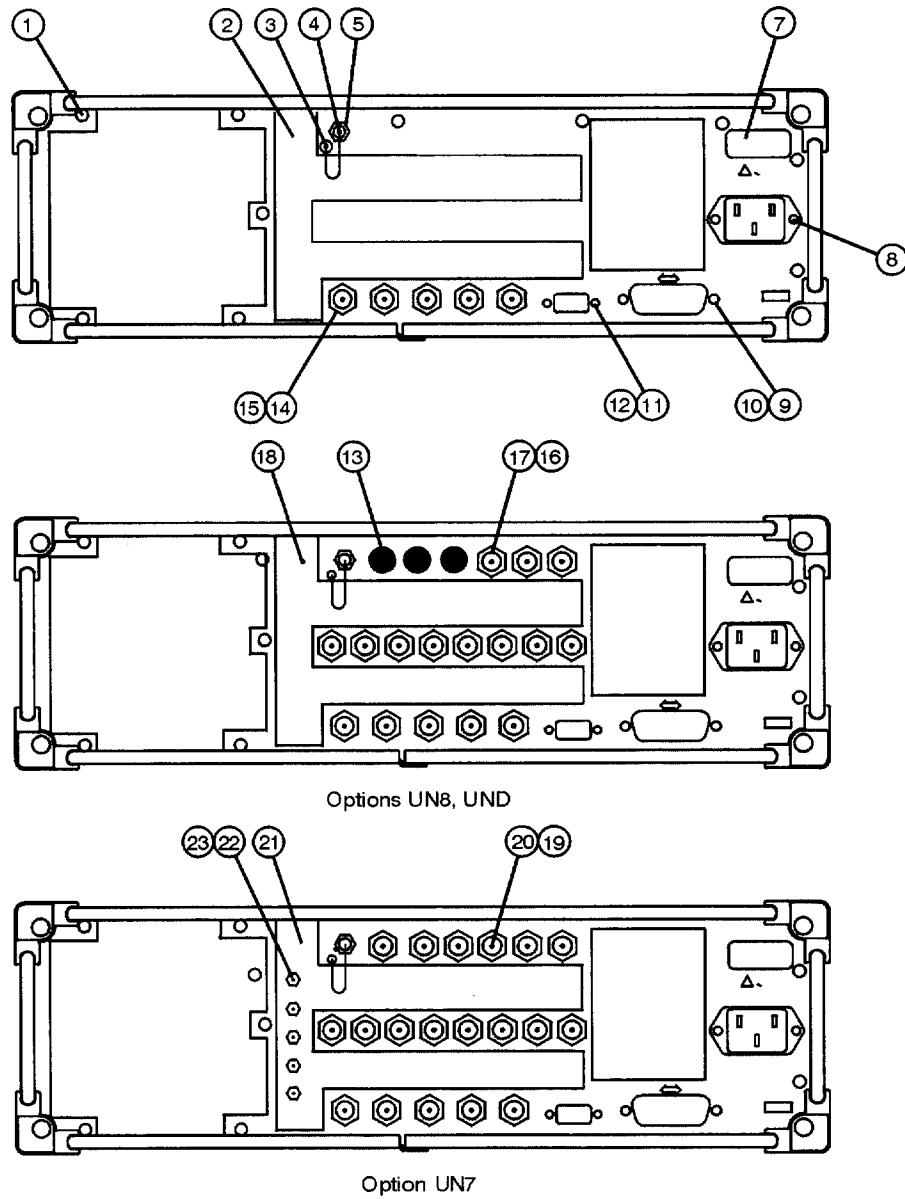

Rear Panel View (ESG-DP Series - Option 1EM)

Refer to Table 4-31 and Figure 4-31.

Table 4-31 Rear Panel View (ESG-DP Series - Option 1EM)

Item No.	Part Number	Qty	Description
1	0515-0372	10	Screw-Machine M3x8 CW-PN-TX
2	E4400-00033	1	Panel-Rear
3	0515-0372	1	Screw-Machine M3x8 CW-PN-TX (used to attach item 4)
4	1250-2759	1	Dust Cap Female SMA
5	1250-1753	1	Adapter-Female SMA to Female SMA
7	2950-0035	5	Nut-Hex 15/32-32
8	2190-0102	5	Washer-Lock .472ID
9	08559-60002	1	RF Output Assy
10	2950-0132	1	Nut-Hex 7/16-28
11	2190-0102	1	Washer-Lock
13	E4400-00017	1	Serial Number Plate
14	0515-1102	2	Screw-Machine M3x8 FL-TX
15	0380-0644	2	Standoff-Hex .327L 6-32
16	2190-0577	2	Washer-Lock
17	0380-2079	2	Standoff-Hex .312L 4-40
18	2190-0003	2	Washer-Lock
19	2950-0054	5	Nut-Hex 1/2-28
20	2190-0068	5	Washer-Lock .505ID
21	E4400-00034	1	Panel-Rear (Option UN8)
22	2950-0078	14	Nut-Hex 10-32 (for the SMBs) (Options UN8, UND)
23	2190-0124	14	Washer-Lock .195ID (for the SMBs) (Options UN8, UND)
24	E4400-00026	1	Panel-Rear (Option UN7)
25	2950-0078	22	Nut-Hex 10-32 (for the SMBs) (Option UN7)
26	2190-0124	22	Washer-Lock .195ID (for the SMBs) (Option UN7)

Figure 4-31 Rear-Panel View (ESG-DP Series - Option 1EM)

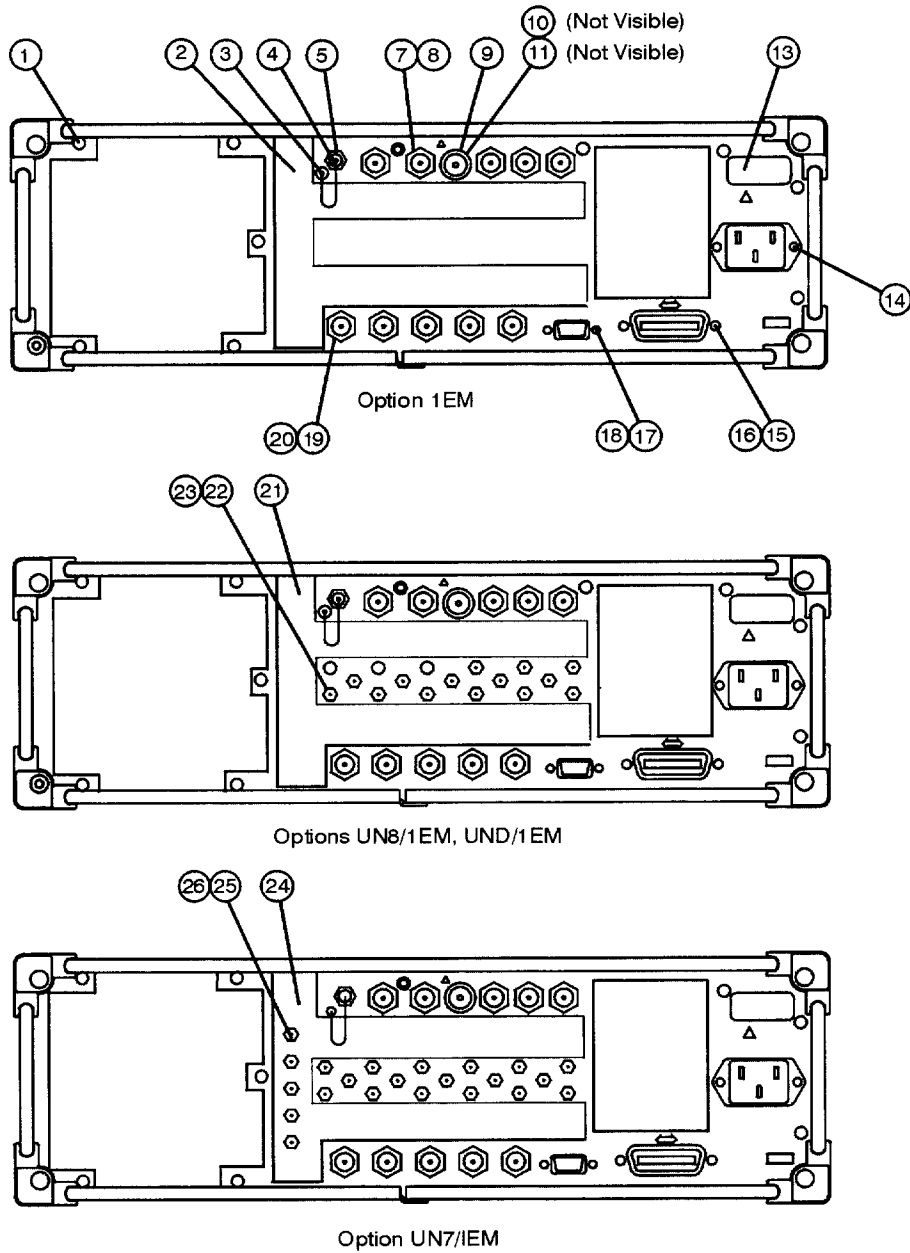

sk7156b

Instrument Chassis with Top and Right-Side Hardware

Refer to Table 4-32 and Figure 4-32.

Table 4-32 Instrument Chassis with Top and Right-Side Hardware

Item No.	Part Number	Qty	Description
1	0515-1269	2	Screw-Machine M4X10 FL-TX
2	0515-2087	4	Screw-Machine M3x6 CW-BN-TX
3	E4400-00003	1	Cover-Side (Serial Prefix US3833, or GB3832, and below)
3	E4400-00037	1	Cover-Side (Serial Prefix US3844, or GB3845, and above)
4	E4400-00035	1	Chassis
5	E4400-00036	1	Cover-Top Chassis
6	0515-0430	11	Screw-Machine M3x6 CW-PN-TX
7	E4423-80002	1	Label-Connection Diagram

Figure 4-32 Instrument Chassis with Top and Right-Side Hardware

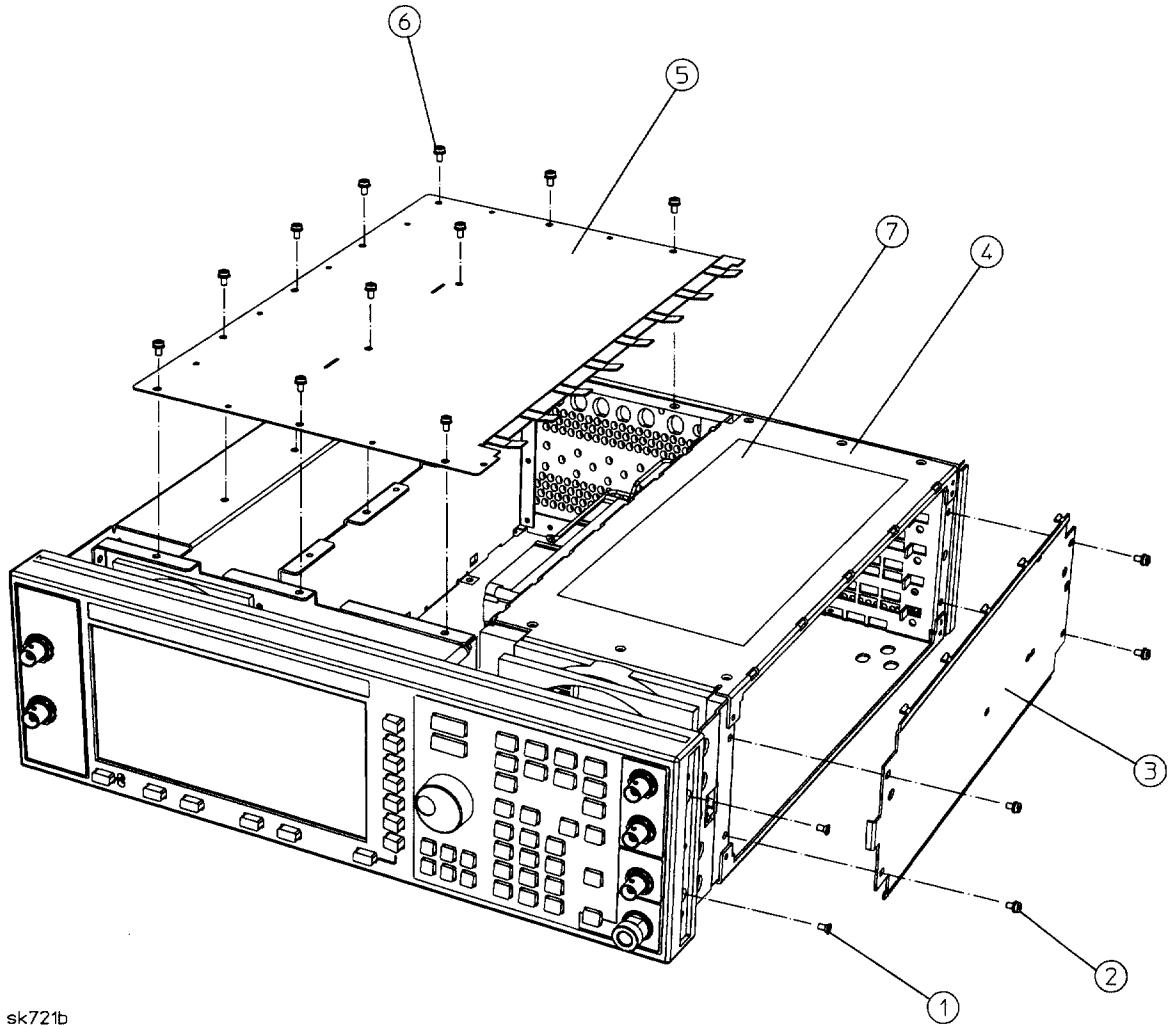

sk721b

Power Supply Shield and Left-Side Hardware

Refer to Table 4-33 and Figure 4-33.

Table 4-33 Power Supply Shield and Left-Side Hardware

Item No.	Part Number	Qty	Description
1	0515-1269	2	Screw-Machine M4X10 FL-TX
2	E4400-00011	1	Shield-Power Supply
3	0515-0372	17	Screw-Machine M3x8 CW-PN-TX

Figure 4-33 Power Supply Shield and Left-Side Hardware

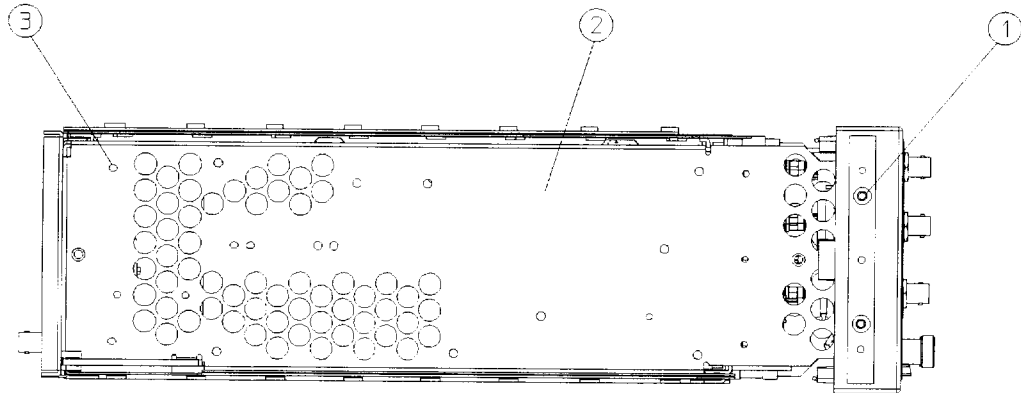

sk706a

Motherboard and Bottom-Side Hardware

Refer to Table 4-34 and Figure 4-34.

Table 4-34 Motherboard and Bottom-Side Hardware

Item No.	Part Number	Qty	Description
1	0515-0372	15	Screw-Machine M3x8 CW-PN-TX
2	E4400-00007	1	Cover-Bottom Chassis
3	0515-0372	2	Screw-Machine M3x8 CW-PN-TX

Figure 4-34 Motherboard and Bottom-Side Hardware

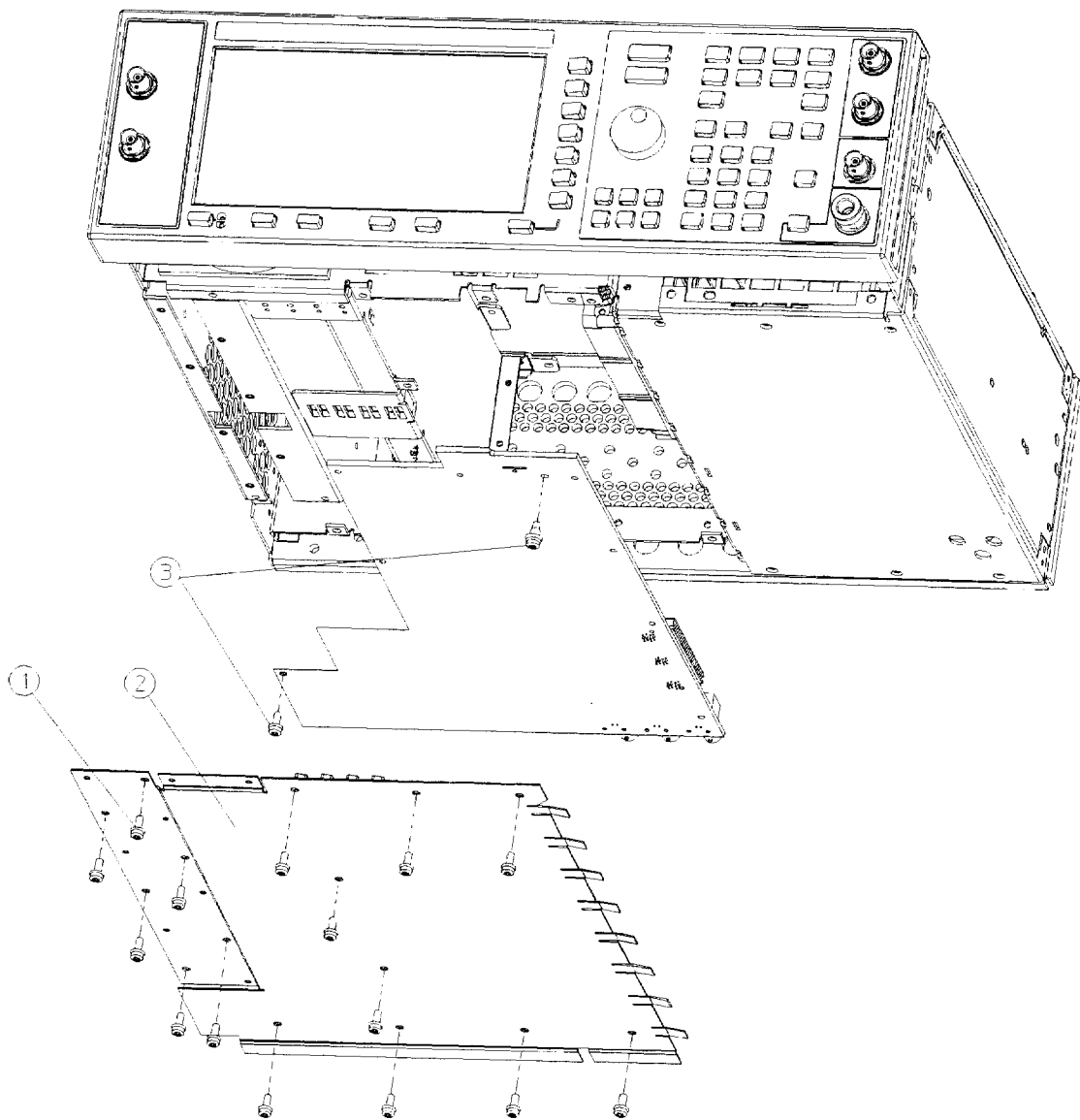

sk7104b

Instrument Cover and Associated Parts

Refer to Table 4-35 and Figure 4-35.

Table 4-35 Instrument Cover and Associated Parts

Item No.	Part Number	Qty	Description
1	0515-1619	4	Screw-Machine M4x25 PN-TX
2	5041-9611	4	Foot-Rear Long
3	5041-9167	4	Feet-Bottom
4	1460-1345	2	Spring-Wire Frame 3.000 Long
5	5041-9171	2	Side Trim
6	E4400-60026	2	Assy-Strap Handle - includes the following parts:
Item 6 includes these parts:	5063-9209	1	Strap Assembly
	E4400-00015	2	Ground Spring
	E4400-20023	2	Handle Retainer
	E4400-40007	2	End Cap
	0515-0710	2	Screw-Machine M5x18 FL-TX
7	E4400-00004	1	Cover-Instrument

Figure 4-35 Instrument Cover and Associated Parts

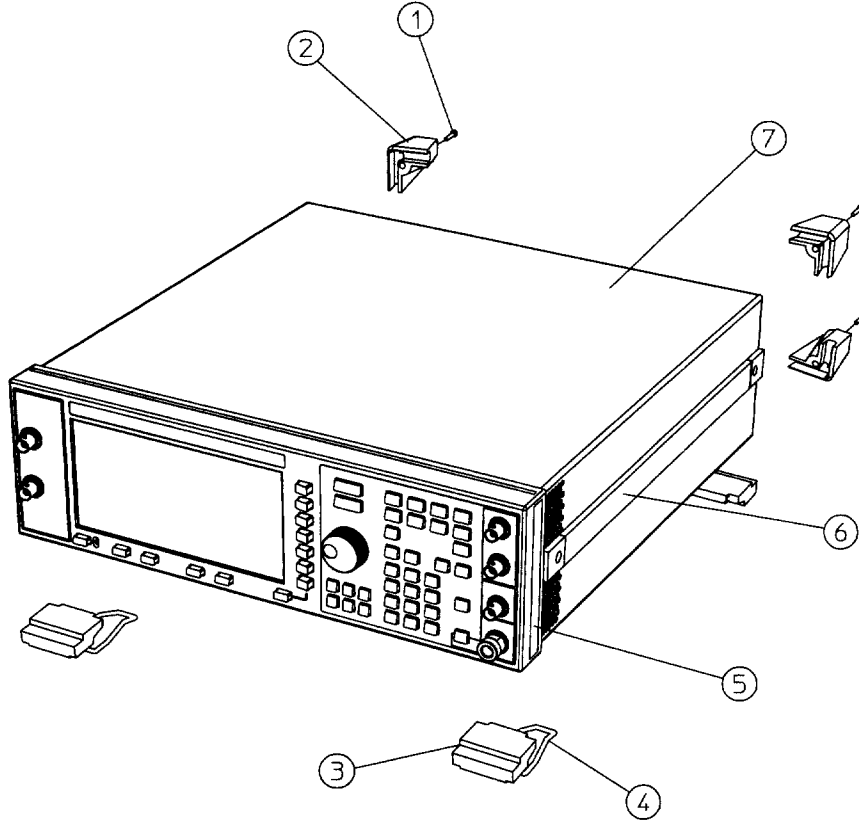

sk755b

Miscellaneous

Miscellaneous

This section lists part numbers for miscellaneous items that can be used with your signal generator. These items are categorized as follows:

- “Accessories” on page 4-66
- “Documentation” on page 4-67
- “Electrostatic Discharge (ESD) Protective Supplies” on page 4-70
- “Upgrade and Retrofit Kits” on page 4-70

Accessories

Refer to Table 4-36.

Table 4-36 Accessories

Description	Part Number
Connector End Cap-RF Output	1401-0247
Connector End Cap-GPIB	1401-5007
Connector End Cap Coherent Carrier Out	1252-4696
Remote Interface	83300A
Transit Case	9211-1296

Documentation

Refer to Table 4-37 and Table 4-38.

Table 4-37 ESG Family Signal Generators Documentation

Description	Part Number
ESG-A and ESG-AP Series Manual Set (includes items listed below)	E4400-90334
User's Guide	E4400-90323
Programming Guide	E4400-90324
Calibration Guide	E4400-90325
Quick Start Guide	E4400-90326
Error Messages	E4400-90333
Technical Specifications	5965-3096E
Feature Releases Document	E4400-90363
ESG-D and ESG-DP Series Manual Set (includes items listed below)	E4400-90322
User's Guide	E4400-90323
Programming Guide	E4400-90324
Calibration Guide	E4400-90325
Quick Start Guide	E4400-90326
Error Messages	E4400-90333
Technical Specifications	5965-3096E
Feature Releases Document	E4400-90363
Option 201 Real-Time cdma2000 Personality User's and Programming Guide	E4400-90386
Option UN8 Real-Time I/Q Baseband Generator with TDMA Standards User's and Programming Guide	E4400-90327
Option UND Dual Arbitrary Waveform Generator and Option UN5 Multichannel, Multicarrier CDMA Personality User's and Programming Guide	E4400-90328
Option 100 W-CDMA Personality User's and Programming Guide	E4400-90329
Option 101 CDMA2000 Personality User's and Programming Guide	E4400-90330
Option UN7 Bit Error Rate Test User's and Programming Guide	E4400-90331
Option 300 Base Station BERT Extension for Option UN7 User's and Programming Guide	E4400-90305
Service Guide	E4400-90335
Component-Level Information	E4400-90336

Miscellaneous

Table 4-38 Localized Documentation for ESG Family Signal Generators

Description	Part Number
Chinese	
User's Guide - Chinese	E4400-90172
Option UN8 DECT User's and Programming Guide - Chinese	E4400-90194
Option UN8 GSM User's and Programming Guide - Chinese	E4400-90201
Option UN8 Custom Digital Modulation User's and Programming Guide - Chinese	E4400-90180
Option UND Dual Arbitrary Waveform Generator and Option UN5 Multichannel, Multicarrier CDMA Personality User's and Programming Guide - Chinese	E4400-90187
Taiwanese	
User's Guide - Taiwanese	E4400-90173
Option UN8 DECT User's and Programming Guide - Taiwanese	E4400-90195
Option UN8 GSM User's and Programming Guide - Taiwanese	E4400-90202
Option UN8 Custom Digital Modulation User's and Programming Guide - Taiwanese	E4400-90181
Option UND Dual Arbitrary Waveform Generator and Option UN5 Multichannel, Multicarrier CDMA Personality User's and Programming Guide - Taiwanese	E4400-90188
French	
User's Guide - French	E4400-90174
Option UN8 DECT User's and Programming Guide - French	E4400-90196
Option UN8 GSM User's and Programming Guide - French	E4400-90203
Option UN8 TETRA User's and Programming Guide - French	E4400-90212
Option UN8 Custom Digital Modulation User's and Programming Guide - French	E4400-90182
Option UND Dual Arbitrary Waveform Generator and Option UN5 Multichannel, Multicarrier CDMA Personality User's and Programming Guide - French	E4400-90189
German	
User's Guide - German	E4400-90175
Option UN8 DECT User's and Programming Guide - German	E4400-90197
Option UN8 GSM User's and Programming Guide - German	E4400-90204
Option UN8 TETRA User's and Programming Guide - German	E4400-90210
Option UN8 Custom Digital Modulation User's and Programming Guide - German	E4400-90183
Option UND Dual Arbitrary Waveform Generator and Option UN5 Multichannel, Multicarrier CDMA Personality User's and Programming Guide - German	E4400-90190

Description	Part Number
Japanese	
User's Guide - Japanese	E4400-90176
Option UN8 DECT User's and Programming Guide - Japanese	E4400-90198
Option UN8 GSM User's and Programming Guide - Japanese	E4400-90205
Option UN8 PDC User's and Programming Guide - Japanese	E4400-90208
Option UN8 PHS User's and Programming Guide - Japanese	E4400-90209
Option UN8 Custom Digital Modulation User's and Programming Guide - Japanese	E4400-90184
Option UND Dual Arbitrary Waveform Generator and Option UN5 Multichannel, Multicarrier CDMA Personality User's and Programming Guide - Japanese	E4400-90191
Option UN7 Bit Error Rate Test User's and Programming Guide - Japanese	E4400-90179
Korean	
User's Guide - Korean	E4400-90177
Option UND Dual Arbitrary Waveform Generator and Option UN5 Multichannel, Multicarrier CDMA Personality User's and Programming Guide - Korean	E4400-90192
Spanish	
User's Guide - Spanish	E4400-90178
Option UN8 DECT User's and Programming Guide - Spanish	E4400-90200
Option UN8 GSM User's and Programming Guide - Spanish	E4400-90207
Option UN8 TETRA User's and Programming Guide - Spanish	E4400-90211
Option UN8 Custom Digital Modulation User's and Programming Guide - Spanish	E4400-90186
Option UND Dual Arbitrary Waveform Generator and Option UN5 Multichannel, Multicarrier CDMA Personality User's and Programming Guide - Spanish	E4400-90193

Miscellaneous**Electrostatic Discharge (ESD) Protective Supplies**

Refer to Table 4-39.

Table 4-39 Electrostatic Discharge (ESD) Protective Supplies

Description	Part Number
2 X 4 Ft Antistatic Table Mat with 15 Ft Ground Wire	9300-0797
5 Ft Grounding Cord (for wrist strap)	9300-0980
Adjustable Antistatic Wrist Strap	9300-1367
Antistatic Heel Strap (for use on conductive floors)	9300-1126

Upgrade and Retrofit Kits

Refer to Table 4-40.

Table 4-40 Upgrade and Retrofit Kits

Description	Part Number
Kit-Firmware Upgrade	E4400-60174
Kit-Firmware Upgrade with ESG-A Series Manual Set	E4400-60171
Kit-Firmware Upgrade with ESG-D Series Manual Set	E4400-60172
Kit-RS-232 Cable	E4400-60049
Kit-Rack Mount Flanges without Handles (Option 1CM)	5063-9214
Kit-Rack Mount Flanges with Handles (Option 1CP)	5063-9221
Retrofit Kit-Rack Slide for Rack Mount	5182-1272
Retrofit Kit-Modified Rack Rail for Rack Mount	5182-1273
Retrofit Kit-Add Option UND to ESG-DP Series	E4400-60166
Retrofit Kit-Upgrade Add Option UN8 to ESG-P Series	E4400-60170
Retrofit Kit-Upgrade Add Option UN9 (Options UN8 and UN9) to ESG-DP Series	E4400-60185

5 Assembly Replacement

This chapter provides removal and replacement procedures for the major assemblies of your signal generator.

Before You Replace an Assembly

Be sure to review the warning and caution statements described in Chapter 7 prior to replacing an assembly in your signal generator.

After Replacing an Assembly

After you have replaced or repaired an assembly, certain performance tests and adjustments may have to be performed. Chapter 6, "Post-Repair Procedures," lists the performance tests and adjustments required for each assembly.

Assemblies That You Can Replace

This chapter provides removal and replacement procedures for the following assemblies:

- A1 Front Panel Board
- A2 Display
- A2DS1 Fluorescent Lamp
- A3 Inverter
- A4 Power Supply
- A4 Power Supply (with Option 1EM)
- A14 CPU/Motherboard
- A14BT1 Battery
- A14Q501 Transistor
- A15 Daughterboard
- A16 Line Module
- A17 and A18 Rear Panel Interface Boards
- A19 Reverse Power Protection (RPP)
- A20 Downconvertor
- A22 YIG Driver
- A25 Pulse Modulator
- A25 Pulse Modulator (with Option UNB)
- AT1 Electronic Attenuator/RPP
- AT1 Mechanical Attenuator
- B1 Small Fan
- B2 Large Fan
- Daughterboard Card Cage Boards
- Digital Card Cage Boards
- Front Panel
- Instrument Cover
- Rear Panel
- Rear Panel (with Option 1EM)
- Semi-Rigid Cables

A1 Front Panel Board

Tools Required

- T-10 TORX screwdriver
- 5/16-inch open-end wrench

Removal

1. Remove the front panel assembly. (Refer to the “Front Panel” replacement procedure on page 5-60.)
2. Remove the small bracket (item 1 in Figure 5-1) that secures W9 (not shown) to the RFI shield (item 2). Disconnect W9.
3. Remove the RFI shield by removing the seven screws (item 3) that secure it.
4. Remove the display (A2) by removing the four screws (item 4) that secure it.
5. Remove the front panel knob (item 5) by pulling it directly away from the front panel.
6. Remove the front panel board (A1) by removing the nine screws (item 6) that secure it.

Replacement

1. Reverse the removal procedure and do the following:
 - Torque all T-10 TORX screws to 9 in-lbs.
 - Torque W9 to 9 in-lbs.

Figure 5-1 A1 Front Panel Board

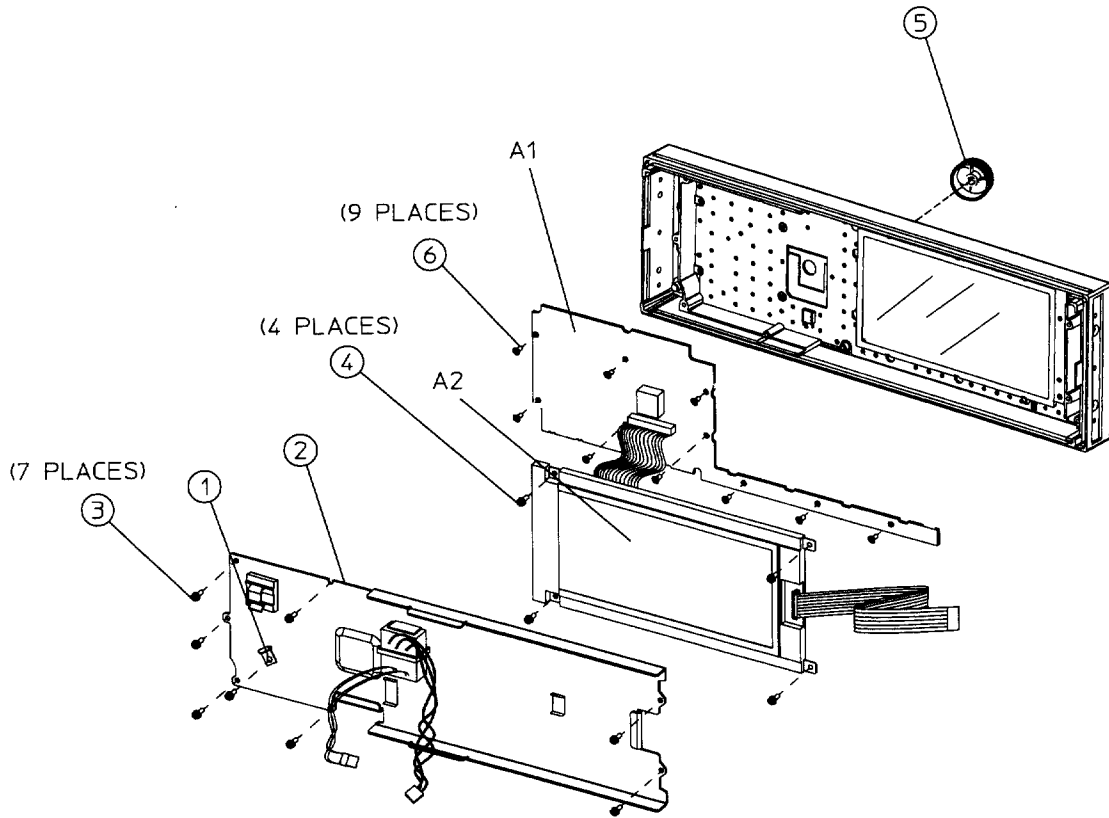

sk7138b

A2 Display

Tools Required

- T-10 TORX screwdriver
- 5/16-inch open-end wrench

Removal

1. Remove the front panel assembly. (Refer to the “Front Panel” replacement procedure on page 5-60.)
2. Remove the small bracket (item 1 in Figure 5-2) that secures W9 (not shown) to the RFI shield (item 2). Disconnect W9.
3. Remove the RFI shield by removing the seven screws (item 3) that secure it.
4. Remove the display (A2) by removing the four screws (item 4) that secure it.

Replacement

1. Reverse the removal procedure and do the following:
 - Torque all T-10 TORX screws to 9 in-lbs.
 - Torque W9 to 9 in-lbs.
 - If you know the part number of the replacement display, on the CPU/motherboard, set the jumpers for P104, P105, and P106 to the correct positions for your display. (See Figure 5-3.)

For part number 2090-0375, set P104, P105, and P106 to the + position.

For part number 1990-1910, set P104, P105, and P106 to the – position.
 - If you *do not* know the part number of the replacement display, do the following:
 - a. On the CPU/motherboard, set the jumpers for P104, P105, and P106 to the + position.

CAUTION Damage can occur to the CPU/motherboard if the signal generator remains turned on for a prolonged period with the jumpers for P104, P105, and P106 positioned incorrectly.

- b. Turn the signal generator on, and observe the display.
- c. If the display does not show text or characters within five seconds, turn the signal generator off and move the jumpers for P104, P105, and P106 to the – position. Repeat the previous step.

- On the A14 CPU/motherboard, set switch #4 on switch pack S201 to the correct position for your display: (See Figure 5-3.)

If P104, P105, and P106 are set to the + position, set switch #4 of S201 to the up (open) position, away from the CPU/motherboard.

If P104, P105, and P106 are set to the - position, set switch #4 of S201 to the down (closed) position, toward the CPU/motherboard.

NOTE Switch #5 of S201 is set to the up (open) position in all circumstances.

NOTE You must reset the signal generator for the switch settings to take effect.

Figure 5-2 A2 Display (1 of 2)

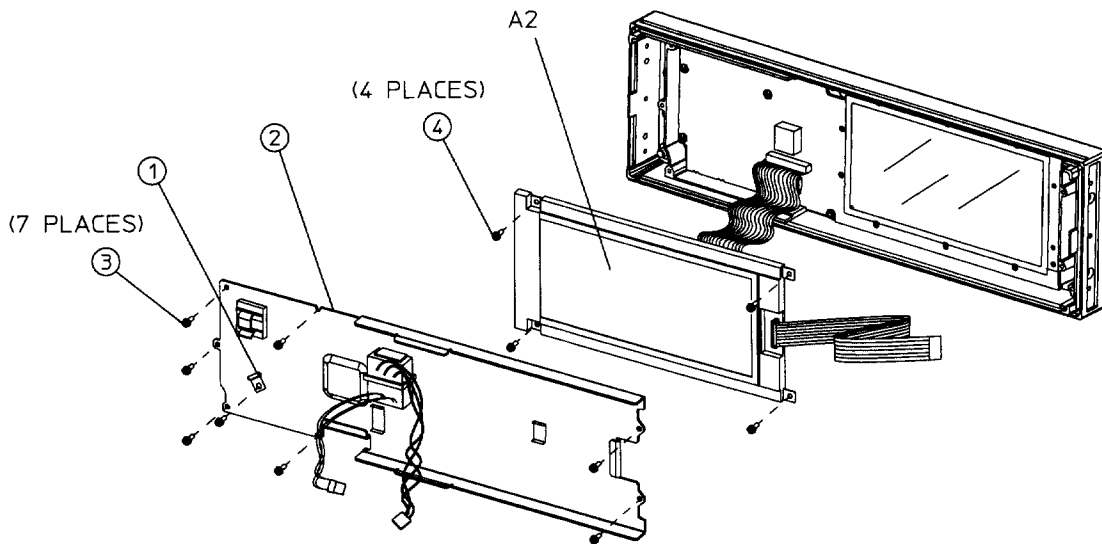

sk7137b

Figure 5-3 A2 Display (2 of 2)

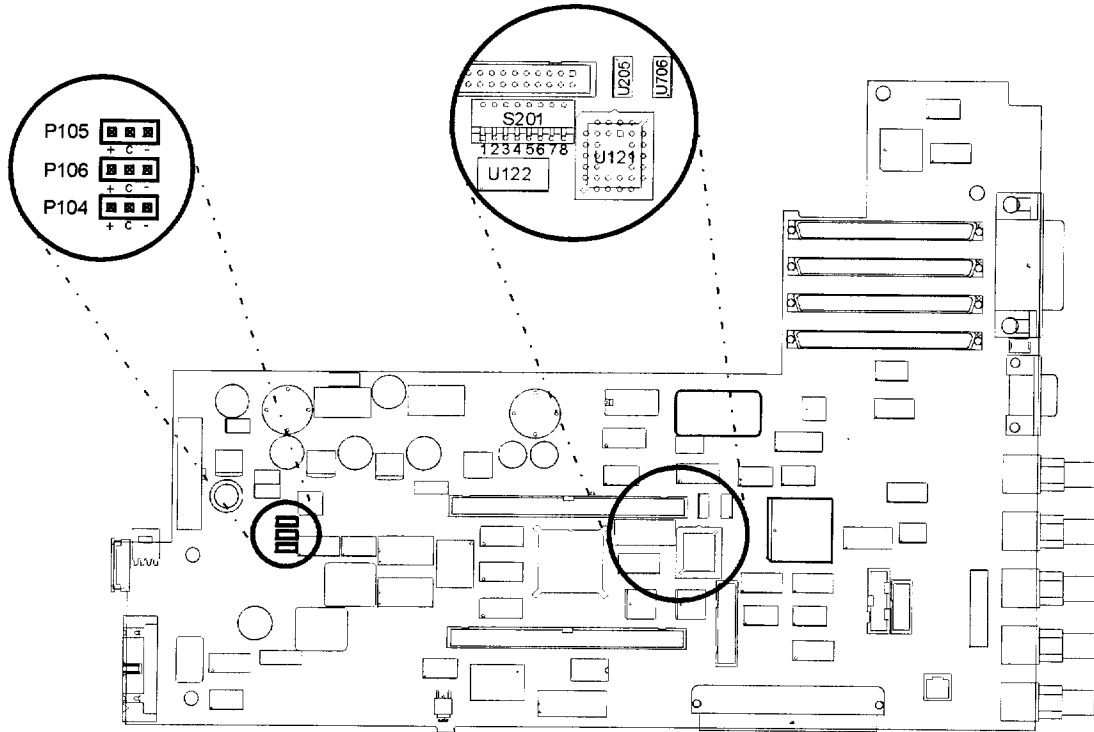

sk7109b

A2DS1 Fluorescent Lamp

Tools Required

- Phillips #0 screwdriver

Removal

1. Remove the display (A2). (Refer to the “A2 Display” replacement procedure on page 5-6.)
2. Loosen the screw (item 1 in Figure 5-4) on the compartment door (item 2) of the display. Remove the door.
3. Remove the fluorescent lamp (A2DS1) from the compartment.

Replacement

1. Reverse the removal procedure. Ensure the lamp is correctly positioned in the reflective paper of the compartment.

Figure 5-4 A2DS1 Fluorescent Lamp

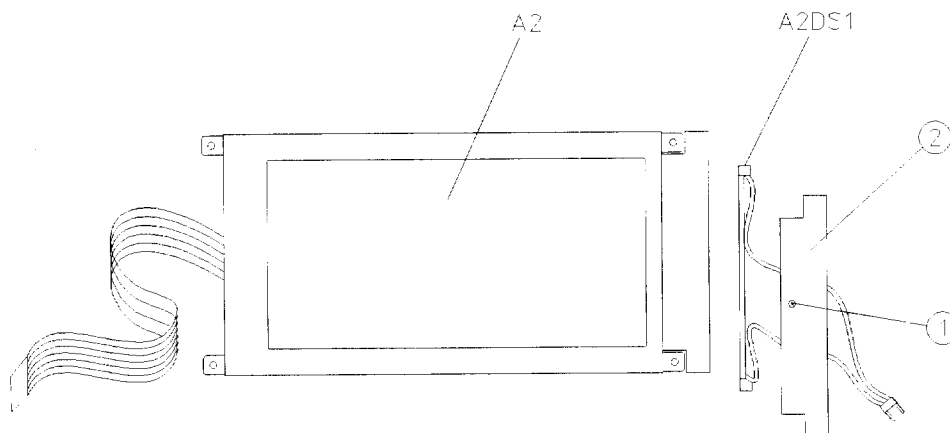

sk744a

A3 Inverter

Tools Required

- wire cutters

Removal

NOTE It is best to attempt this procedure without removing the front panel assembly. If the front panel assembly is removed, you will be required to perform time-consuming “Power Level Accuracy” verification tests and adjustments.

1. Remove the instrument cover. (Refer to the “Instrument Cover” replacement procedure on page 5-64.)
2. Disconnect A3W2 from A2DS1W1. (See Figure 5-5.)
3. Cut the tie wrap (item 1) that secures the inverter (A3) to the RFI shield (item 2).
4. Remove the inverter.

Replacement

1. Reverse the removal procedure and secure the inverter (A3) with a new tie wrap.

Figure 5-5 A3 Inverter

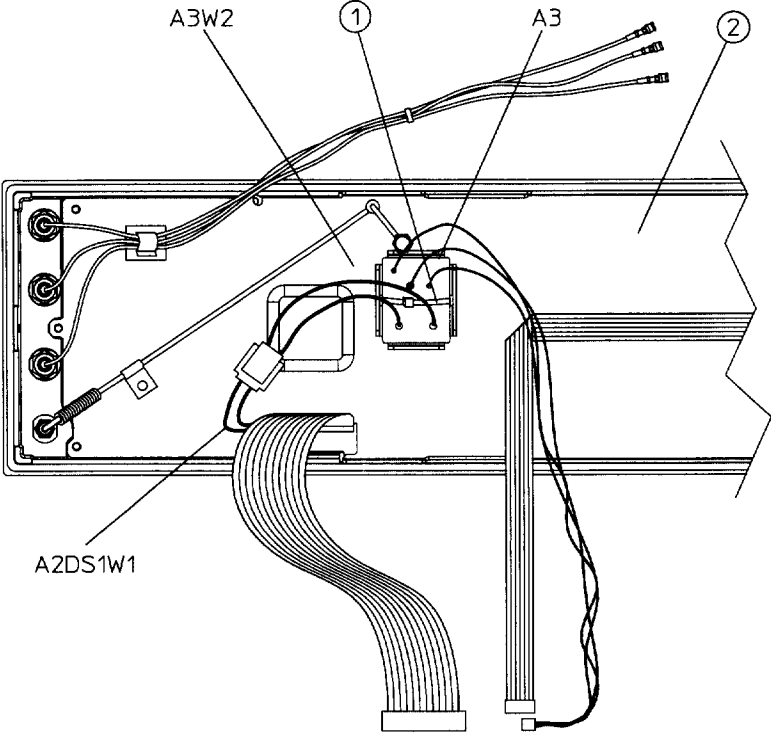

sk7136b

A4 Power Supply

Tools Required

- T-10 TORX screwdriver
- T-15 TORX screwdriver

Removal

1. Remove the rear panel assembly. (Refer to the “Rear Panel” replacement procedure on page 5-66.)
2. Remove the screw (item 1 in Figure 5-6) that attaches the CPU/motherboard (A14) to the bottom of the power supply shield (item 2).
3. Disconnect A4W1 from the CPU/motherboard (A14). (See Figure 5-7 on page 5-14.)
4. Carefully peel off the side trim (item 3) from the left side of the front panel assembly (item 4).
5. Remove the two screws (item 5) that attach the power supply shield (item 2) to the front panel assembly.
6. Remove the five screws (item 6) that attach the power supply shield to the instrument chassis (item 7).
7. Lift the rear of the power supply shield one-quarter inch and then pull it away from the instrument chassis.

NOTE While removing the power supply shield, try to limit the movement of the front panel assembly. This will reduce the stress on W9.

8. Remove the 12 screws (item 8) that attach the power supply to the power supply shield.
9. Remove the power supply (A4) from the front end of the shield.

NOTE Before proceeding to the next step ensure that the instrument is fully supported on a flat surface. This will keep the front panel assembly stable during the time it is attached only to the right side of the instrument.

Replacement

1. Reverse the removal procedure and do the following:
 - Torque all T-10 TORX screws to 9 in-lbs.
 - Torque all T-15 TORX screws to 21 in-lbs.

Figure 5-6 A4 Power Supply (1 of 2)

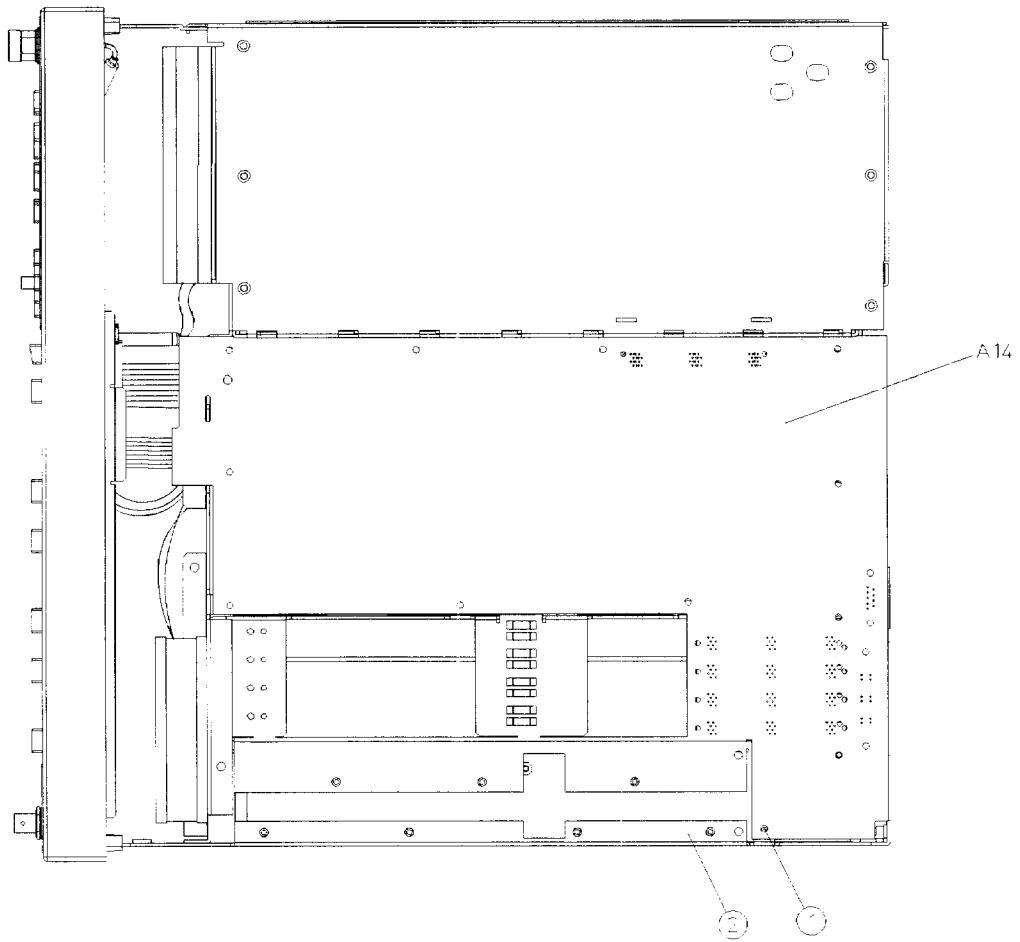

sk71285

Figure 5-7 A4 Power Supply (2 of 2)

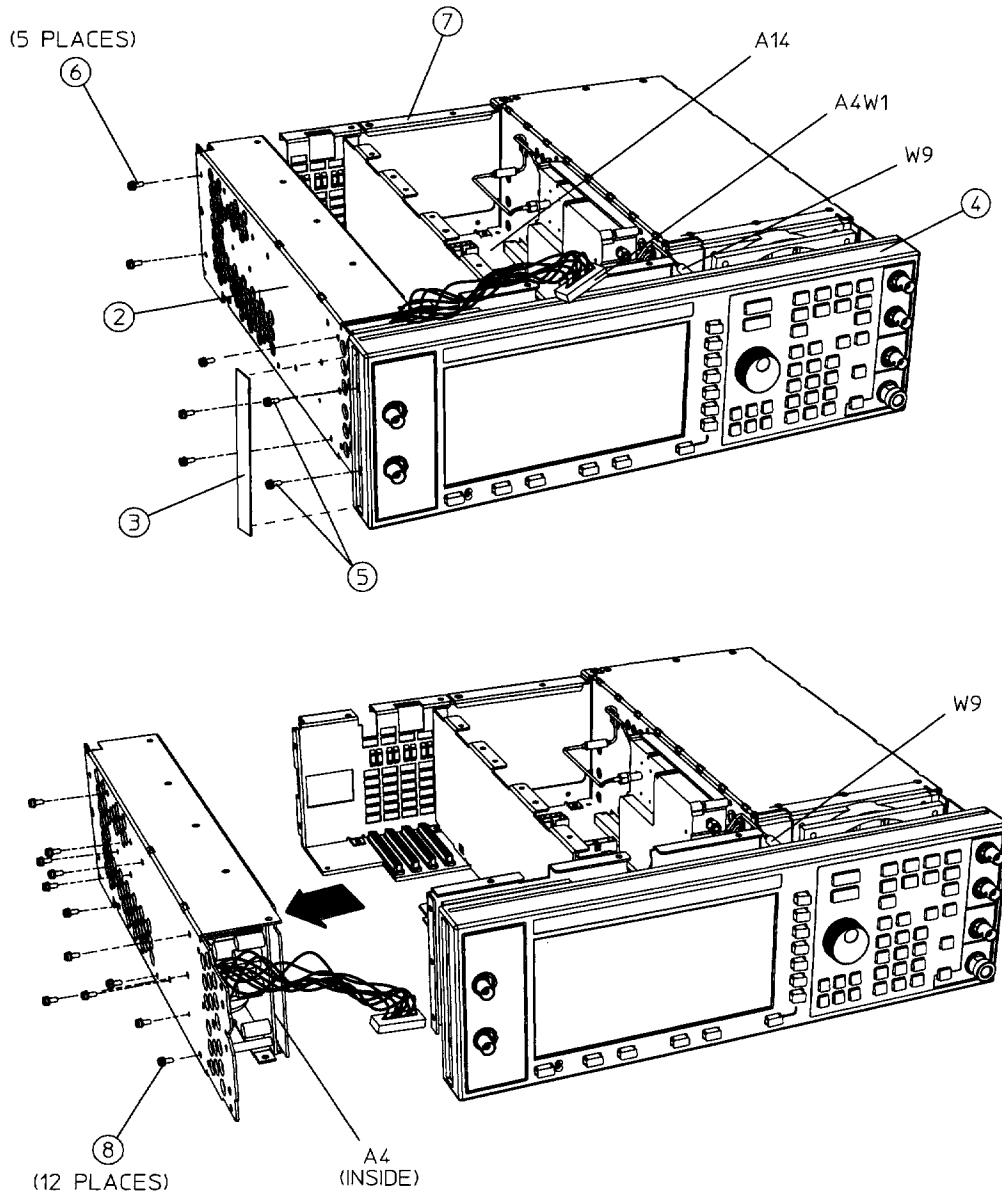

sk726b

A4 Power Supply (with Option 1EM)

Tools Required

- T-10 TORX screwdriver

Removal

1. Remove the front panel assembly. (Refer to the “Front Panel” replacement procedure on page 5-60.)
2. Remove the bottom cover by removing the 15 screws that secure it.
3. Remove the screw (item 1 in Figure 5-8) that attaches the CPU/motherboard (A14) to the bottom of the power supply shield (item 2).
4. Disconnect A16W1 from the power supply (A4).
5. Remove the two screws (item 3) that attach the line module (A16) to the rear panel.
6. Remove the line module and A16W1 from the opening in the rear panel. The line module will remain connected to the rear panel, however, via the ground wire, A16W2. (See Figure 5-9 on page 5-17.)
7. Remove the three screws (item 4 in Figure 5-8) that attach the rear panel to the power supply shield.
8. Disconnect A4W1 from the CPU/motherboard (A14). (See Figure 5-9 on page 5-17.)
9. Remove the five screws (item 5) that attach the power supply shield (item 2) to the instrument chassis (item 6).
10. Pull the power supply shield away from the instrument chassis.
11. Remove the 12 screws (item 7) that attach the power supply to the power supply shield.
12. Remove the power supply (A4) from the front end of the shield.

Replacement

1. Reverse the removal procedure and torque all T-10 TORX screws to 9 in-lbs.

Figure 5-8 A4 Power Supply (with Option 1EM) (1 of 2)

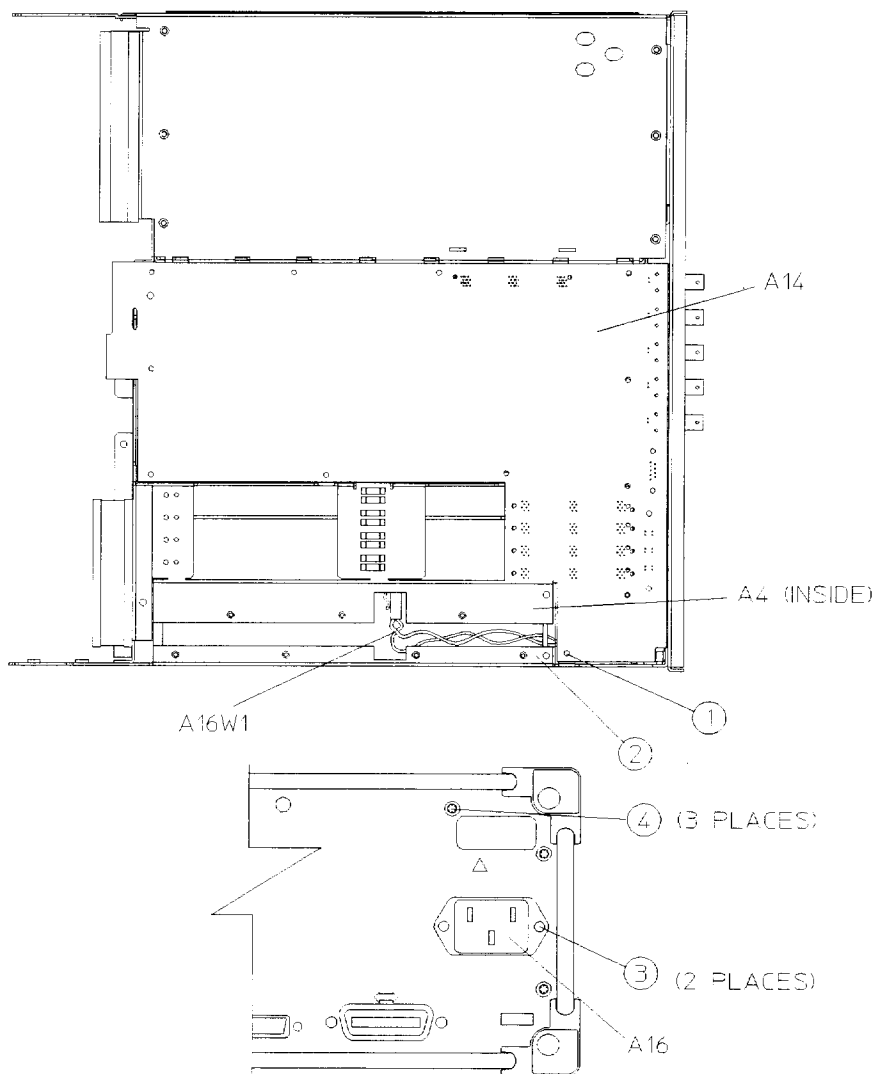

sk7127b

Figure 5-9 A4 Power Supply (with Option 1EM) (2 of 2)

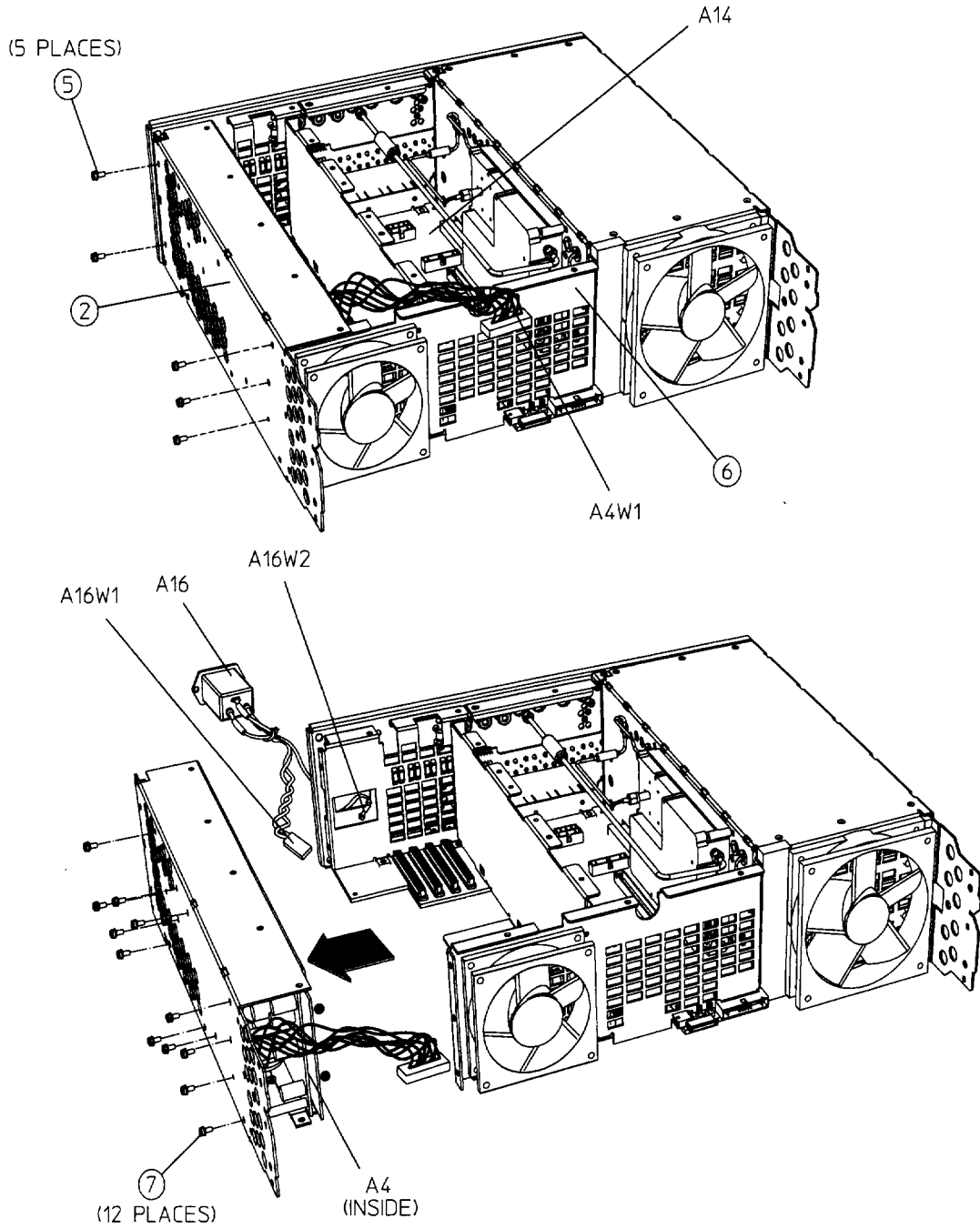

sk727b

A14 CPU/Motherboard

Tools Required

- T-10 TORX screwdriver
- EEPROM extraction tool (Part Number 8710-1982)

Removal

1. Remove the rear panel assembly. (Refer to the “Rear Panel” replacement procedure on page 5-66 or, if you have Option 1EM, refer to the “Rear Panel (with Option 1EM)” replacement procedure on page 5-70.)
2. Remove all of the boards in the digital card cage (if installed for your model). (Refer to the “Digital Card Cage Boards” replacement procedure on page 5-58.)
3. Disconnect A1W1, A3W1, A4W1, B1W1, B2W1, W10, and W13 from the CPU/motherboard (A14). (See Figure 5-10.)
4. Disconnect A14Q501 from the CPU/Motherboard.

If A14Q501 is attached to the back of the CPU/Motherboard (as it is in older models), this step is not necessary.

5. If you have Option UNB, also disconnect A19W1 from the CPU/motherboard.

If you have Option 1E6, also disconnect A25W1 from the CPU/motherboard.

6. If you have an ESG-A Series or ESG-AP Series signal generator, go to step 7.

If you have an ESG-D Series or ESG-DP Series signal generator, disconnect W25 and W26 from the CPU/motherboard (A14).

For all current models, disconnect W3, W4, and W5 from the CPU/motherboard, otherwise go to step 7.

NOTE Figure 5-10 represents an Option UN7/UND.

Figure 5-10 A14 CPU/Motherboard (1 of 3)

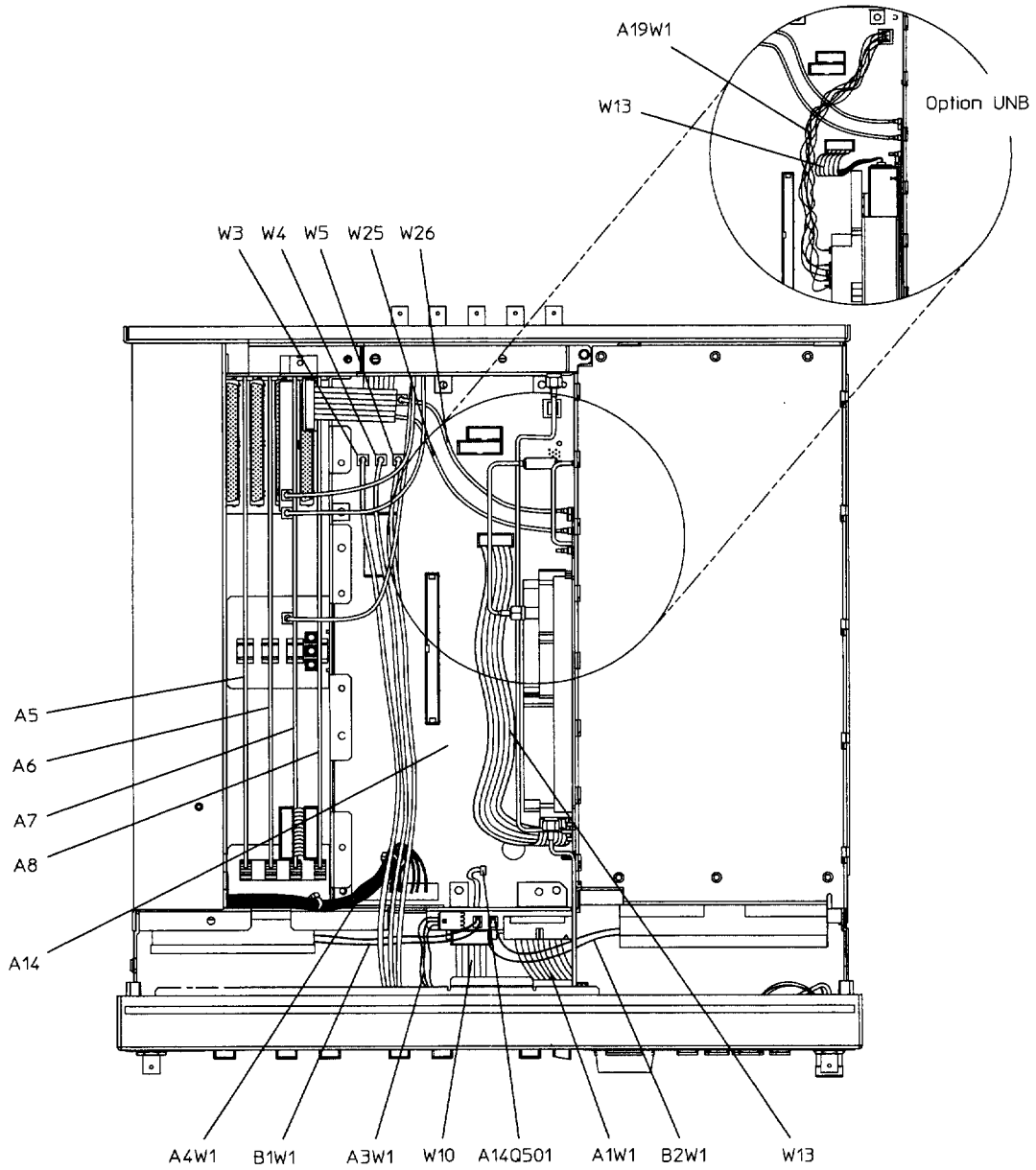

sk7121b

7. Turn the signal generator upside-down and remove the screw (item 1 in Figure 5-11) from the CPU/motherboard (A14).
8. Remove the screw (item 2) from the CPU/motherboard.

NOTE In some models, this screw secures transistor A14Q501 to the chassis. In this case, the screw is installed with an insulator bushing. Be careful not to lose it when removing the screw.

9. Remove the CPU/motherboard.
10. Notice how the jumper connections are set for P104, P105, and P106. (You will need this information when you replace the board.) (See Figure 5-12.) Some CPU/motherboards do not have these components.
11. If the CPU/motherboard includes removable devices in locations U106 and U107, label each device and remove them using the extraction tool. (See Figure 5-12.)

Replacement

1. Insert U106 and U107 into their respective sockets on the replacement CPU/motherboard.

CAUTION U106 and U107 hold critical data including the serial number, option configuration, and calibration information. You must transfer these devices to the new CPU/motherboard for the signal generator to work.

2. Reverse the removal procedure and do the following:
 - When reinstalling the CPU/motherboard, remember to insert the tab and daughterboard connector into the corresponding slots of the instrument chassis before securing it with the screws.
 - Torque the two T-10 TORX screws to 9 in-lbs.
 - Refer to replaceable parts chapter for your signal generator model to verify that the cables are reconnected in the correct locations. (Refer to Chapter 3 for the ESG-A and ESG-D series, refer to Chapter 4 for the ESG-AP and ESG-DP series.)
3. On the CPU/motherboard, set the jumpers for P104, P105, and P106 to the same positions as the previous board. (See Figure 5-12.)

If the previous CPU/motherboard did not have P104, P105, and P106, set the jumpers to the – position.
4. If you *do not* know how the jumpers for P104, P105, and P106 were set on the previous CPU/motherboard, do the following:
 - a. On the CPU/motherboard, set the jumpers for P104, P105, and P106 to the + position.

CAUTION Damage can occur to the CPU/motherboard if the signal generator remains turned on for a prolonged period with the jumpers for P104, P105, and P106 positioned incorrectly.

- b. Turn the signal generator on, and observe the display.
 - c. If the display does not show text or characters within five seconds, turn the signal generator off and move the jumpers for P104, P105, and P106 to the - position. Repeat the previous step.
5. On the A14 CPU/motherboard, set switch #4 on switch pack S201 to the correct position for your display:
- If P104, P105, and P106 are set to the + position, set switch #4 of S201 to the up (open) position, away from the CPU/motherboard. (See Figure 5-12.)
- If P104, P105, and P106 are set to the - position, set switch #4 of S201 to the down (closed) position, toward the CPU/motherboard. (See Figure 5-12.)

NOTE Switch #5 of S201 is set to the up (open) position in all circumstances.

NOTE You must reset the signal generator for the switch settings to take effect.

Figure 5-11 A14 CPU/Motherboard (2 of 3)

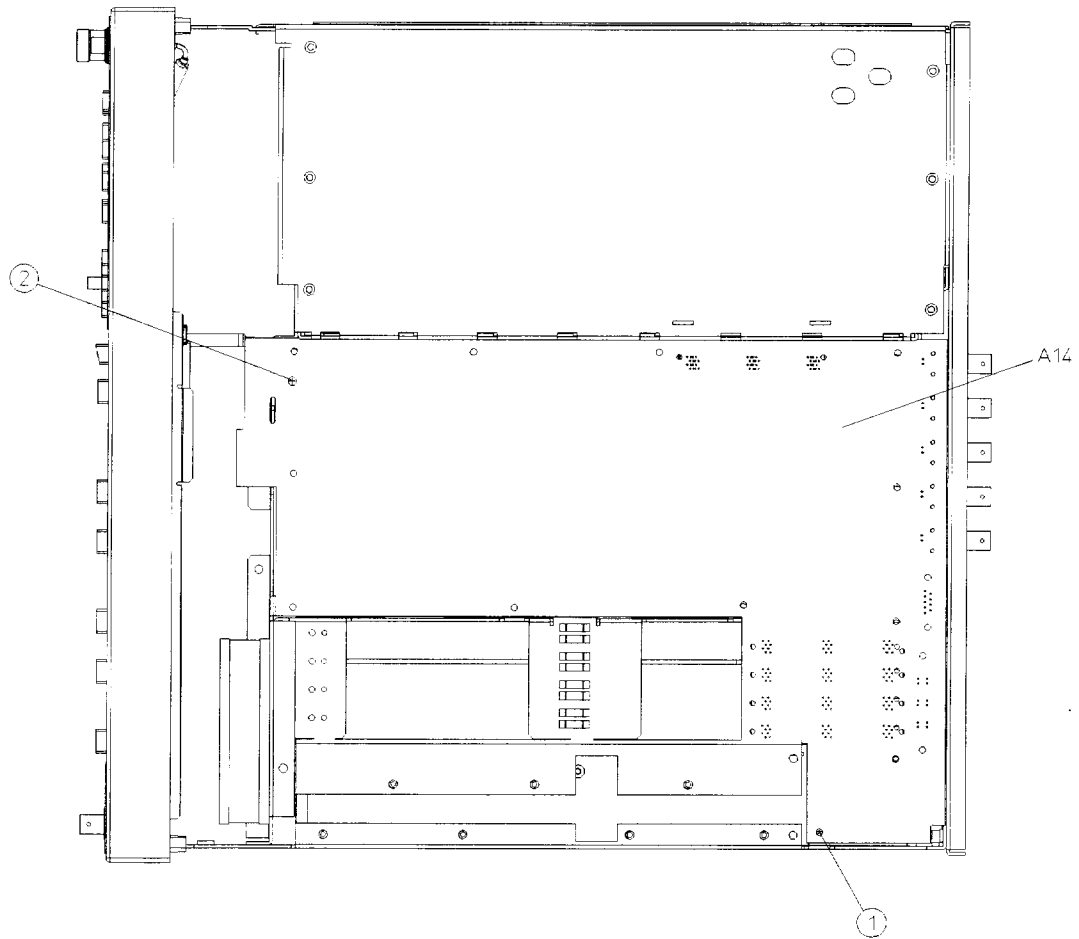

sk7120b

Figure 5-12 A14 CPU/Motherboard (3 of 3)

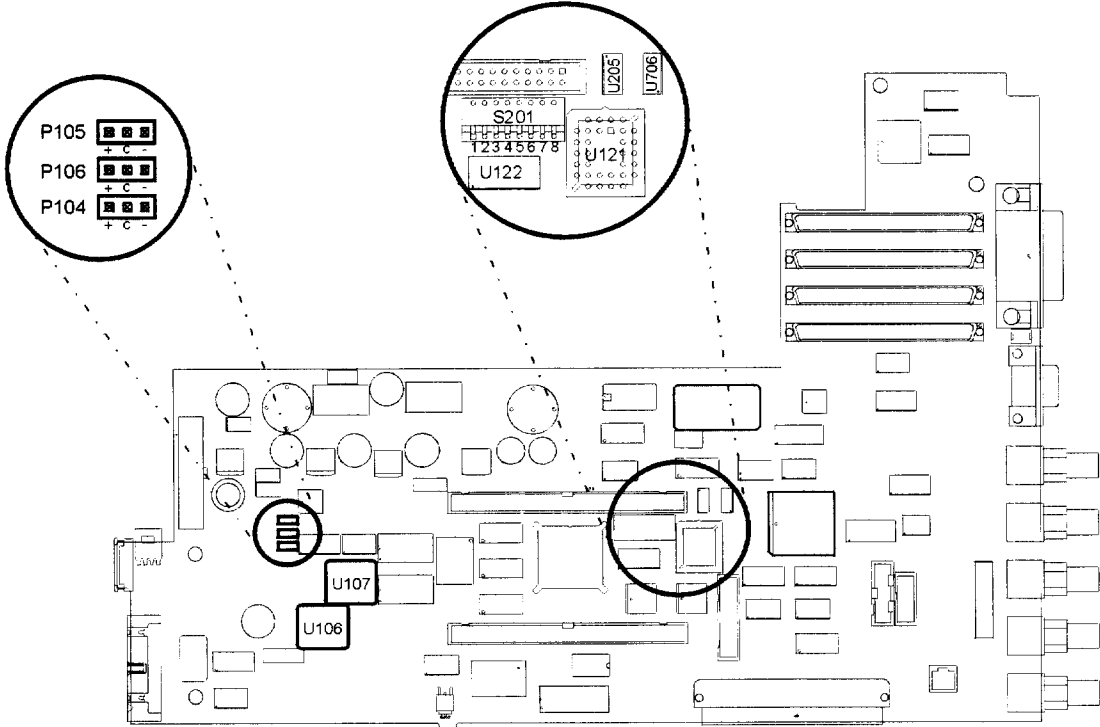

sk7105b

A14BT1 Battery

Tools Required

- T-10 TORX screwdriver
- soldering tools
- utility knife
- Dow Corning 3145 RTV Clear Adhesive Sealant (part number 0470-0450)

Removal

1. Remove the instrument cover. (Refer to the “Instrument Cover” replacement procedure on page 5-64.)
2. Remove the top cover by removing the 11 screws that secure it.
3. Remove the bottom cover by removing the 15 screws that secure it.
4. Unsolder the leads of the battery (A14BT1) from the CPU/motherboard (A14). (See Figure 5-13.)

CAUTION Calibration data will be preserved with the removal of the battery. However, user data will be lost unless it is saved and later restored using an external controller.

5. The battery is also attached to the CPU/motherboard with a silicon adhesive. Using a utility knife, carefully cut through the adhesive to lift and remove the battery from the CPU/motherboard.

WARNING Battery A14BT1 contains lithium. Do not incinerate or puncture this battery. Dispose of the discharged battery in a safe manner. Refer to Chapter 7, “Safety and Regulatory,” for instructions on how to dispose of the battery.

6. Remove any excess adhesive from the CPU/motherboard surface.

Replacement

WARNING Danger of explosion if battery is incorrectly replaced. Replace only with the same or equivalent type recommended. Discard used batteries according to manufacturer’s instructions.

1. Apply a small amount of silicon adhesive to the battery’s location on the CPU/motherboard.
2. Insert the new battery into the CPU/motherboard making sure it is oriented with the correct polarity.
3. Solder the battery’s leads to the CPU/motherboard.

4. Reassemble the instrument.

Figure 5-13 A14BT1 Battery

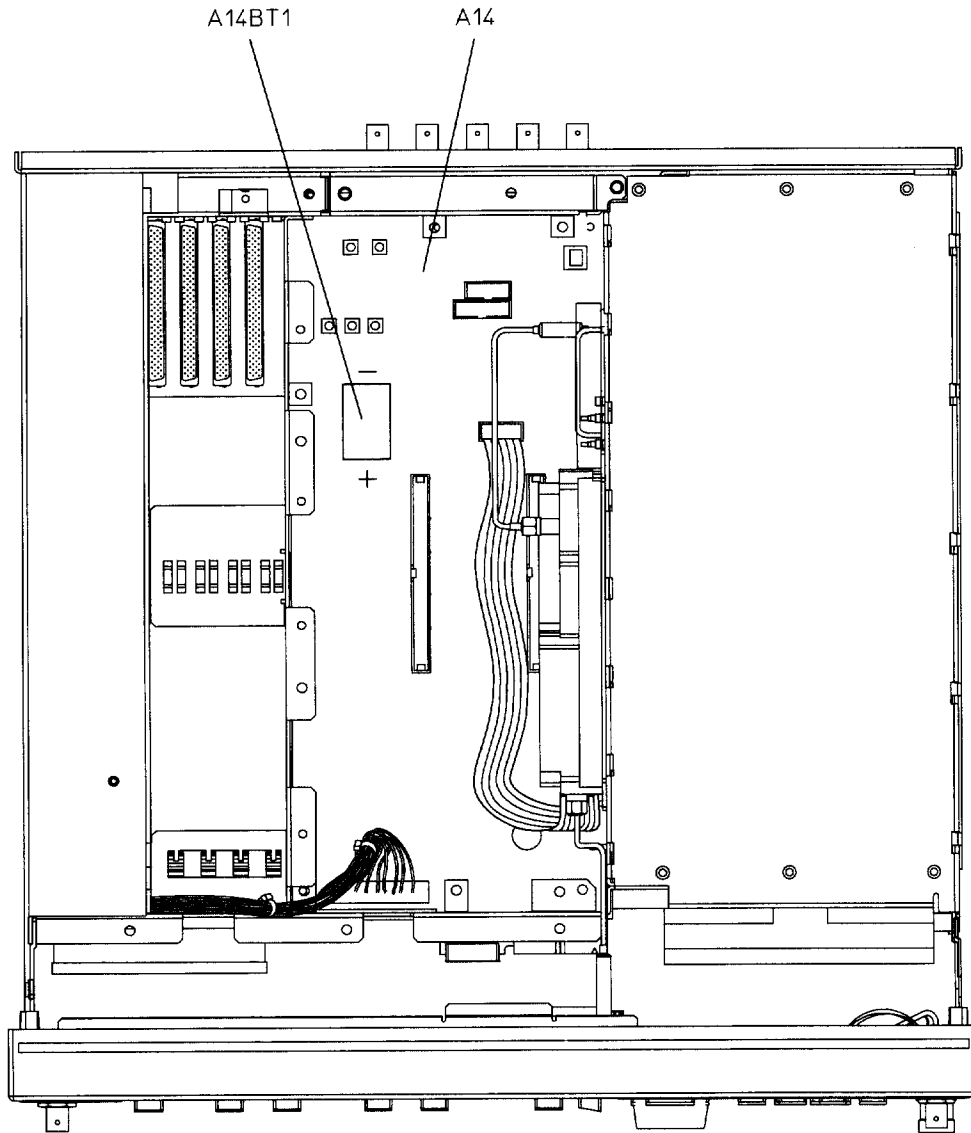

sk733b

A14Q501 Transistor

Tools Required

- T-10 TORX screwdriver

Removal

1. Remove the instrument cover. (Refer to the “Instrument Cover” replacement procedure on page 5-64.)
2. Disconnect the transistor assembly (item 1 in Figure 5-14) leads from the CPU/motherboard (A14).
3. Remove the screw (item 2) that attaches the transistor assembly to the chassis.
4. Remove the transistor assembly (item 1), the shoulder washer (item 3), and, if necessary, the insulator pad (item 4).

Replacement

1. Reverse the removal procedure and torque the T-10 TORX screw to 9 in-lbs.

Figure 5-14 A14Q501 Transistor

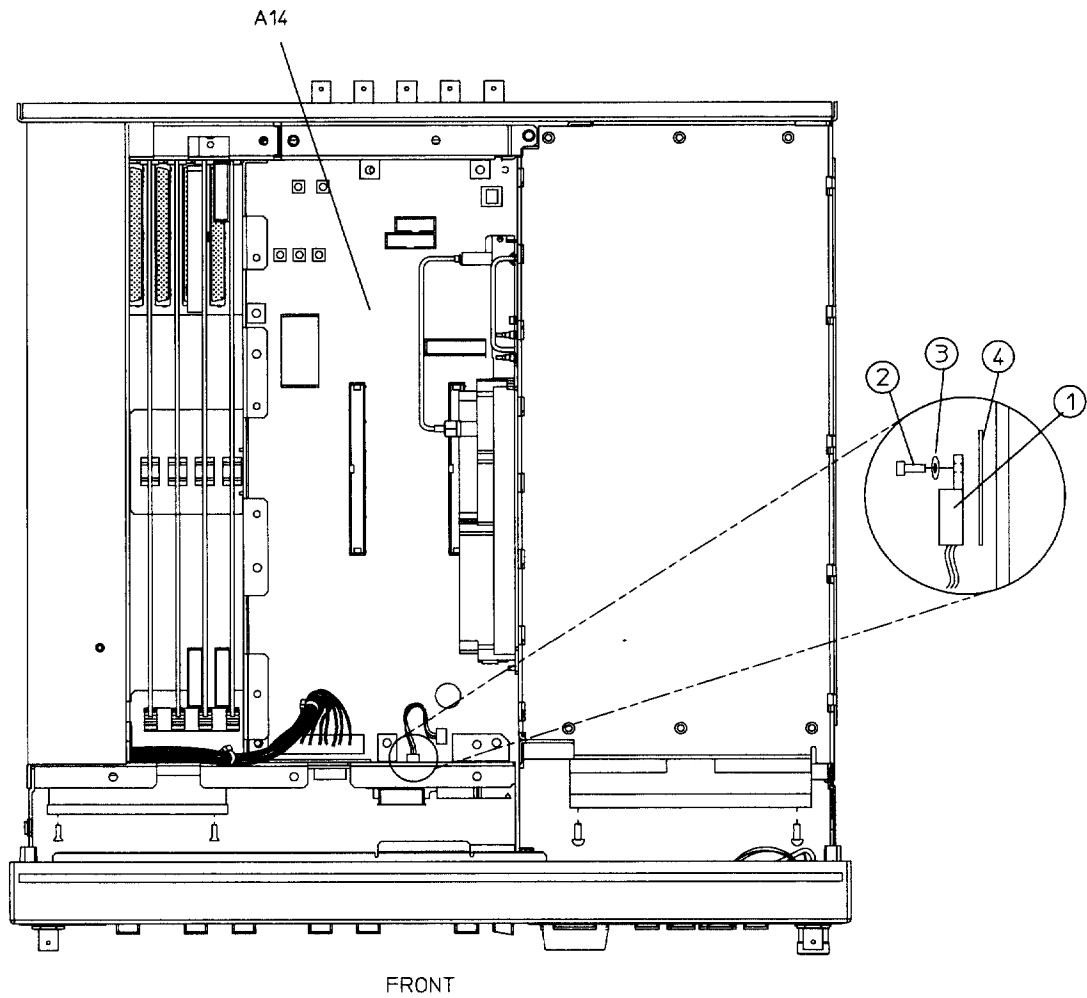

sk7132b

A15 Daughterboard

Tools Required

- T-8 TORX screwdriver
- T-10 TORX screwdriver
- long nose pliers

Removal

1. Remove the instrument cover. (Refer to the “Instrument Cover” replacement procedure on page 5-64.)
2. Remove the top cover by removing the 11 screws that secure it.
3. Remove all of the flexible cables connected to the daughterboard (A15). (See Figure 5-15.)
4. Remove the right-side cover (not shown) by first removing the four screws that attach it to the instrument chassis. Then push down on the cover while sliding it towards the front of the instrument to unhook its tabs from the slots on the top of the chassis.

Figure 5-15 A15 Daughterboard (1 of 2)

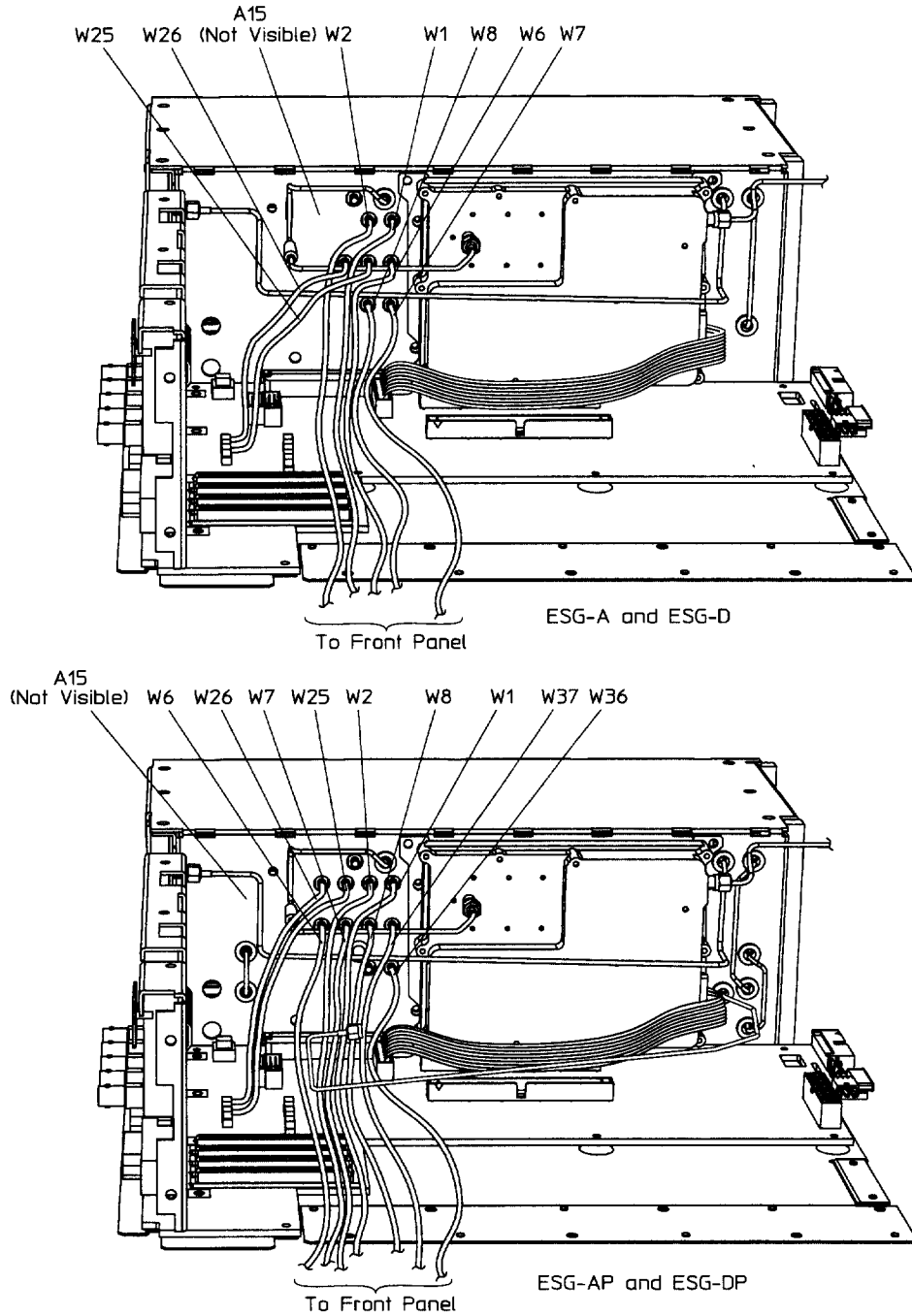

sk7135b

5. Simultaneously lift the left and right extractors (item 1 in Figure 5-16) on each of the daughterboard card cage boards, and remove them from the card cage slots.

NOTE Figure 5-16 shows an ESG-A or ESG-D series instrument. ESG-AP and ESG-DP series instruments contain four boards in the daughterboard card cage.

6. Remove the five screws (item 2) that attach the daughterboard (A15) to the instrument chassis.
7. Remove the daughterboard.

Replacement

1. Reverse the removal procedure and do the following:
 - Torque all T-8 TORX screws to 9 in-lbs.
 - Torque all T-10 TORX screws to 9 in-lbs.
 - Refer to replaceable parts chapter for your signal generator model to verify that the cables are reconnected in the correct locations. (Refer to Chapter 3 for the ESG-A and ESG-D series, refer to Chapter 4 for the ESG-AP and ESG-DP series.)

Figure 5-16 A15 Daughterboard (2 of 2)

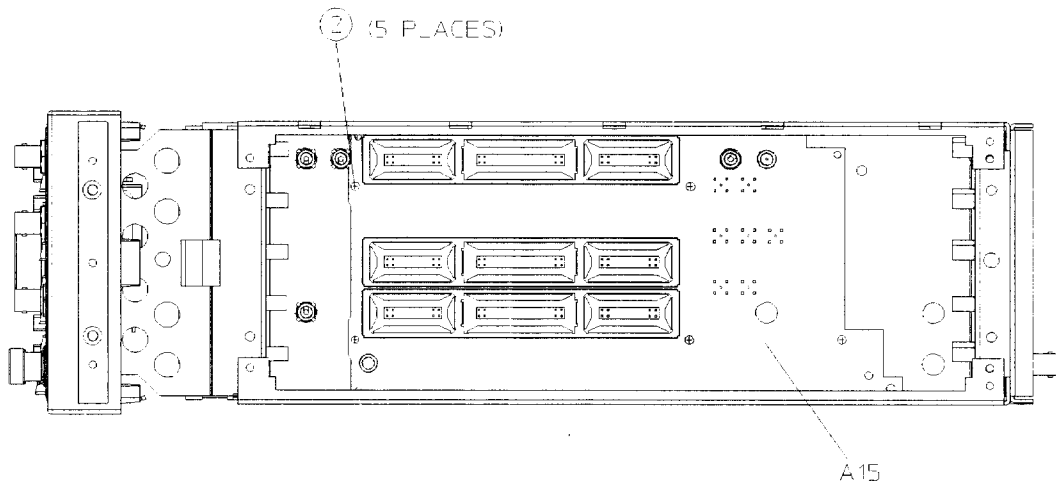
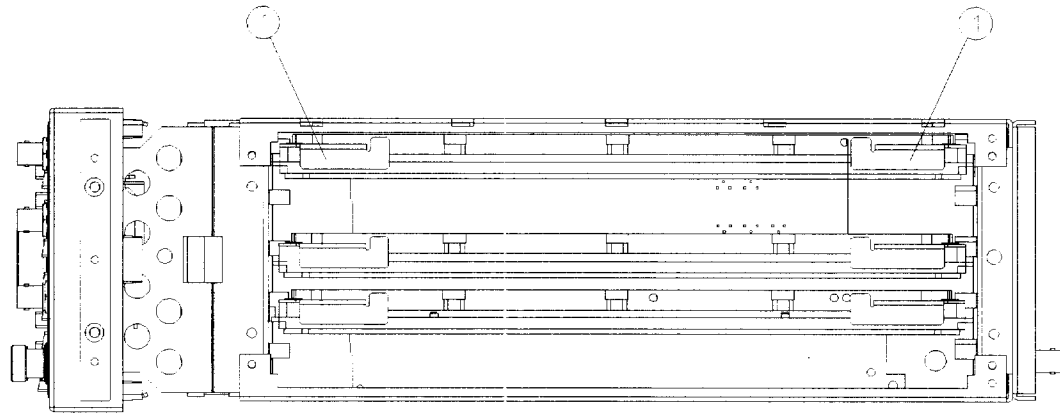

st 7119b

A16 Line Module

Tools Required

- T-10 TORX screwdriver
- 5.5-mm wrench or nut driver

Removal

1. Remove the rear panel assembly. (Refer to the “Rear Panel” replacement procedure on page 5-66 or, if you have Option 1EM, refer to the “Rear Panel (with Option 1EM)” replacement procedure on page 5-70.)
2. Remove the nut (item 1 in Figure 5-17) that attaches the line module’s ground wire (A16W2) to the inside of the rear panel.
3. Remove the two screws (item 2) that attach the line module (A16) to the rear panel.
4. Remove the line module from the opening in the rear panel.

Replacement

1. Reverse the removal procedure and do the following:
 - Torque the 5.5-mm nut that attaches the ground wire to the rear panel to 9 in-lbs.
 - Torque all T-10 TORX screws to 9 in-lbs.

Figure 5-17 A16 Line Module

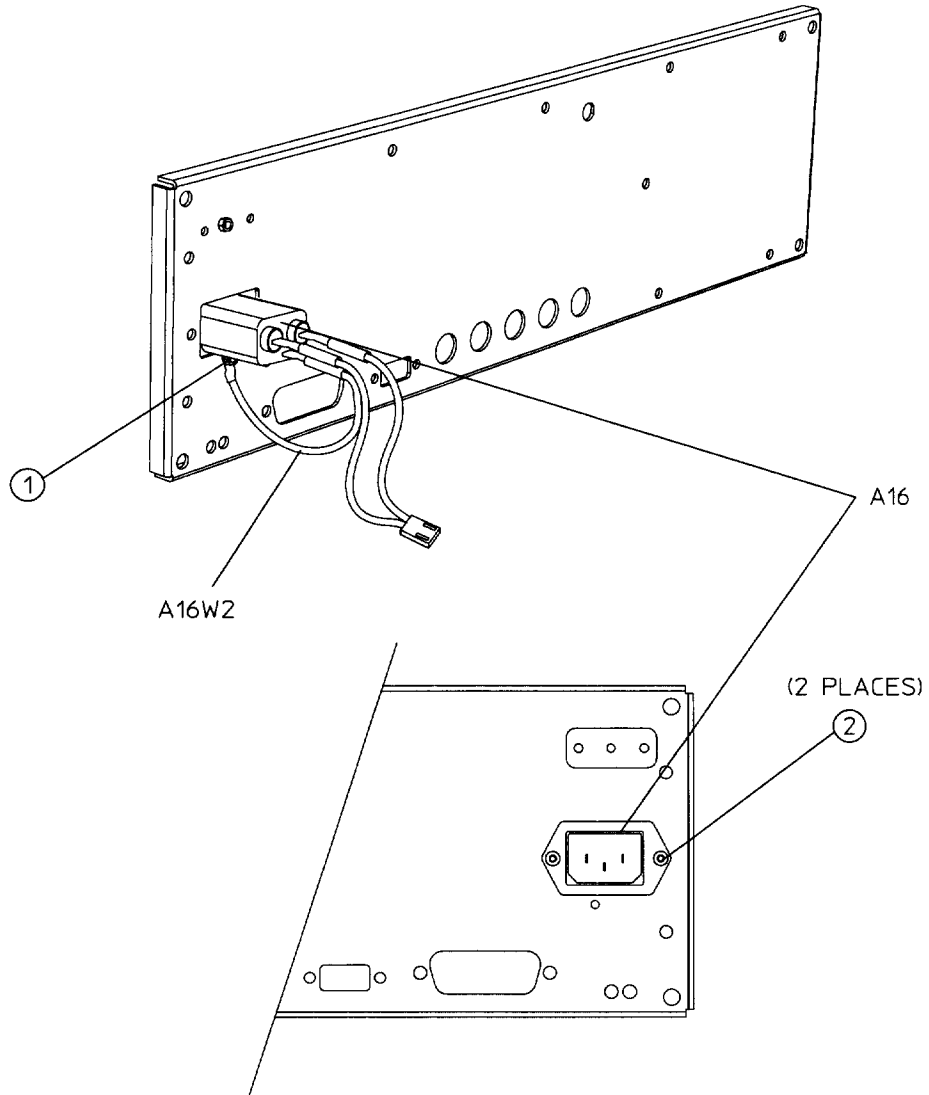

sk736b

A17 and A18 Rear Panel Interface Boards

Tools Required

- 5/8-inch wrench or nut driver
- 1/4-inch wrench or nut driver (Option 1EM)

Removal

1. Remove the rear panel assembly. (Refer to the “Rear Panel” replacement procedure on page 5-66 or, if you have Option 1EM, refer to the “Rear Panel (with Option 1EM)” replacement procedure on page 5-70.)
2. Depending on the option of your signal generator, do the following: (See Figure 5-18.)

Options UN3, UN4, UN8. Remove the nuts (item 1) and washers (item 2) on the eight BNC connectors of the rear panel. Remove the rear panel interface board (A17) from the rear panel.

Options 1EM/UN3, 1EM/UN4, 1EM/UN8. Remove the nuts (item 3) and washers (item 4) on eight of the associated SMB connectors on the rear panel. Remove the rear panel interface board (A17) from the rear panel.

Option UN7. Remove the nuts (item 5) and washers (item 6) on five of the associated SMB connectors on the rear panel. Remove the BER rear panel interface board (A18) from the rear panel.

Replacement

1. Reverse the removal procedure and do the following:
 - Torque the 5/8-inch BNC nuts to 21 in-lbs.
 - If you have Option 1EM, torque the 1/4-inch SMB nuts to 14 in-lbs.

Figure 5-18 A17 and A18 Rear Panel Interface Boards

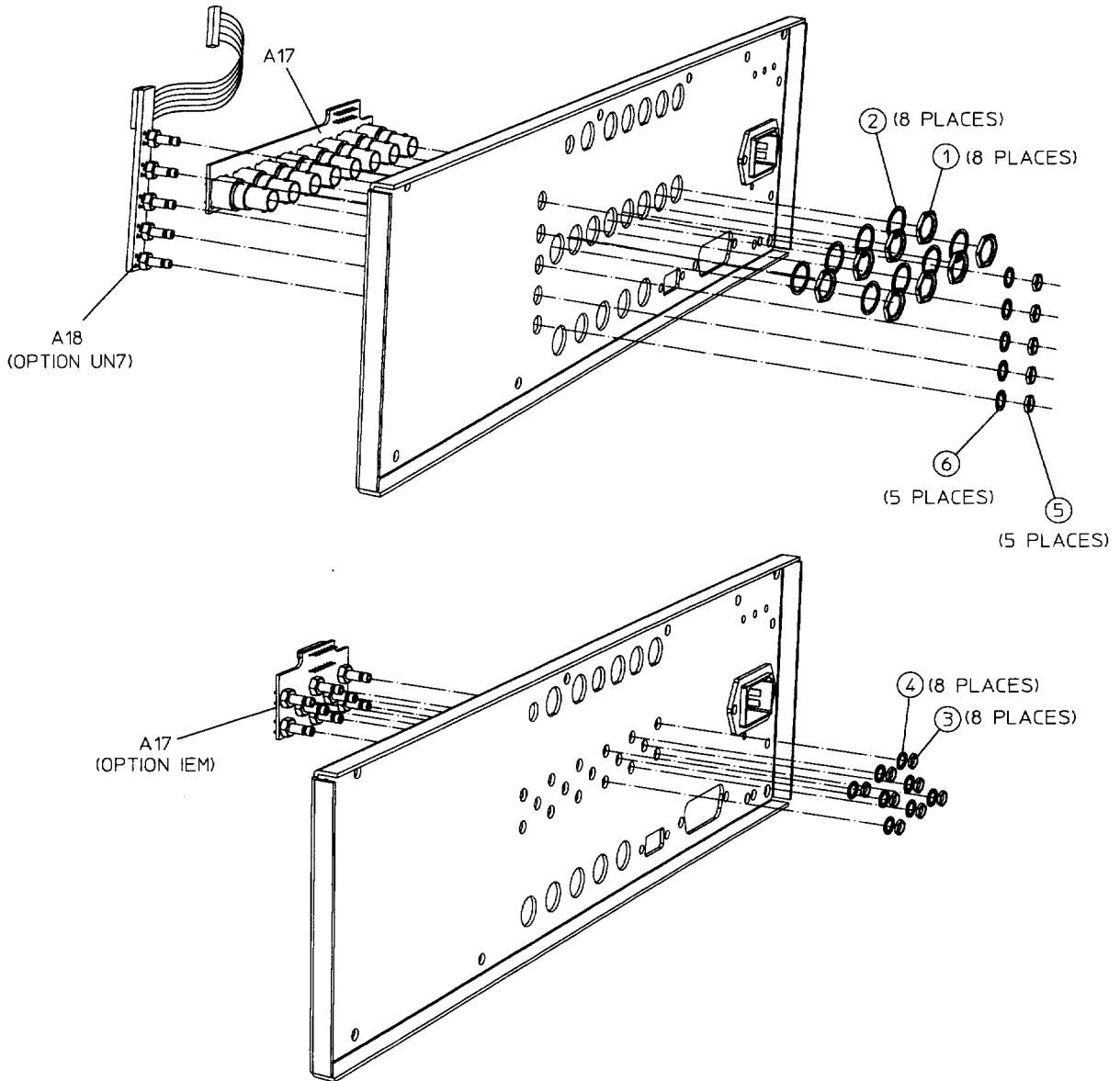

sk737b

A19 Reverse Power Protection (RPP)

Tools Required

- T-10 TORX screwdriver
- 5/16-inch open-end wrench

Removal

1. Remove the instrument cover. (Refer to the “Instrument Cover” replacement procedure on page 5-64.)
2. Remove the top cover by removing the 11 screws that secure it.
3. If you have Option 1E6, disconnect W45 and W47 from the pulse modulator (A25) and A25W1 from the CPU/motherboard (A14). (See Figure 5-19)

If you *do not* have Option 1E6, disconnect W14 from the mechanical attenuator (AT1). (See Figure 5-20.)

4. Disconnect A19W1 from the CPU/motherboard.
5. Disconnect W9 from the RPP (A19).
6. Disconnect W13 from the CPU/motherboard.
7. Remove the two screws (item 1) that attach the attenuator/RPP assembly to the instrument chassis.
8. Tilt the assembly away from the chassis wall, then carefully lift it out of the instrument.

NOTE There are two hinged tabs at the bottom of the attenuator/RPP assembly that fit into slots in the instrument chassis. Therefore, it is necessary to tilt the assembly away from the chassis wall so that the tabs can be guided out of the slots.

9. Disconnect W20 from the RPP and the mechanical attenuator (AT1).
10. If you have Option 1E6, disconnect W46 from the pulse modulator and the mechanical attenuator. (See Figure 5-19)
11. Remove the four screws (item 2 in Figure 5-21) that attach the RPP bracket (item 3) to the attenuator bracket (item 4).
12. Remove the three screws (item 5) that attach the RPP bracket to the RPP.

Replacement

1. Reverse the removal procedure and do the following:
 - When reinstalling the electronic attenuator/RPP assembly, remember to insert its hinged tabs into the slots located at the base of the chassis wall on which the assembly will be mounted.
 - Torque all semi-rigid cables to 9 in-lbs.
 - Torque all screws to 9 in-lbs.

Figure 5-19 A19 Reverse Power Protection (RPP) (1 of 3)

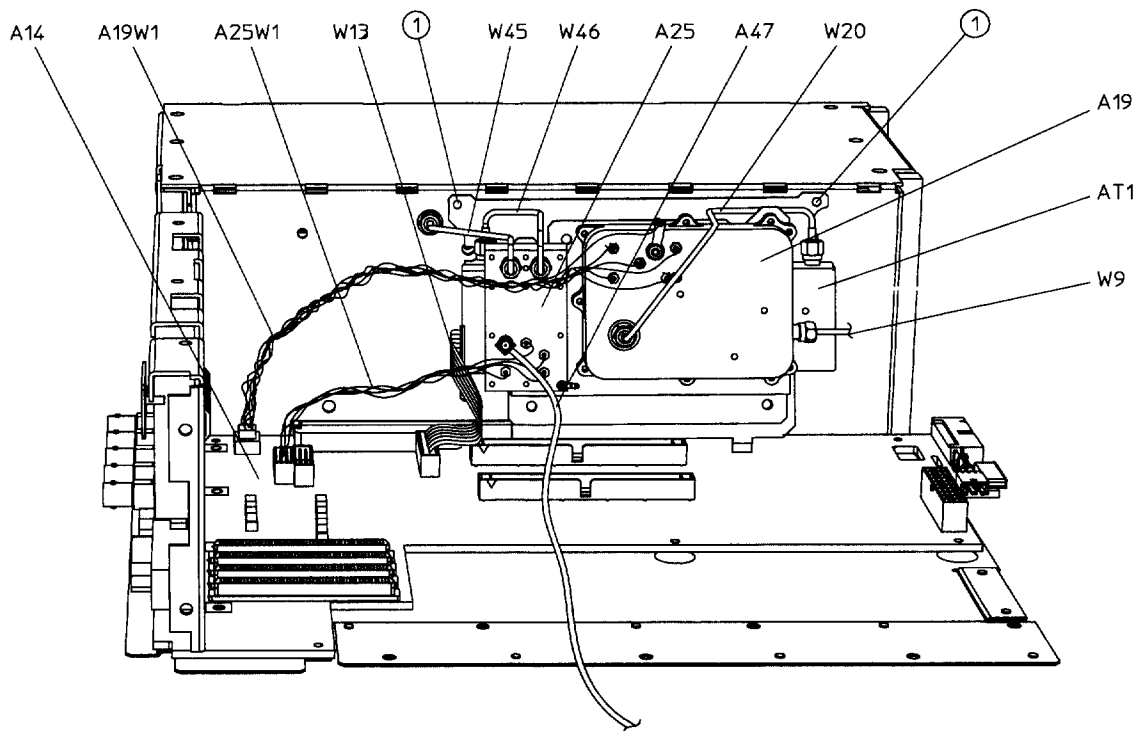

sk7153b

Figure 5-20 A19 Reverse Power Protection (RPP) (2 of 3)

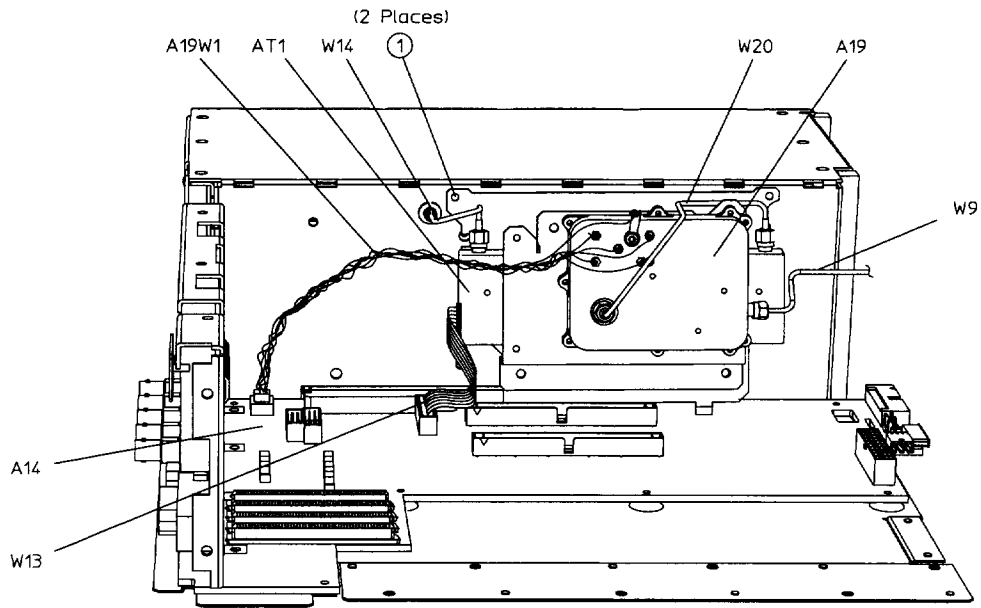

sk738b

Figure 5-21 A19 Reverse Power Protection (RPP) (3 of 3)

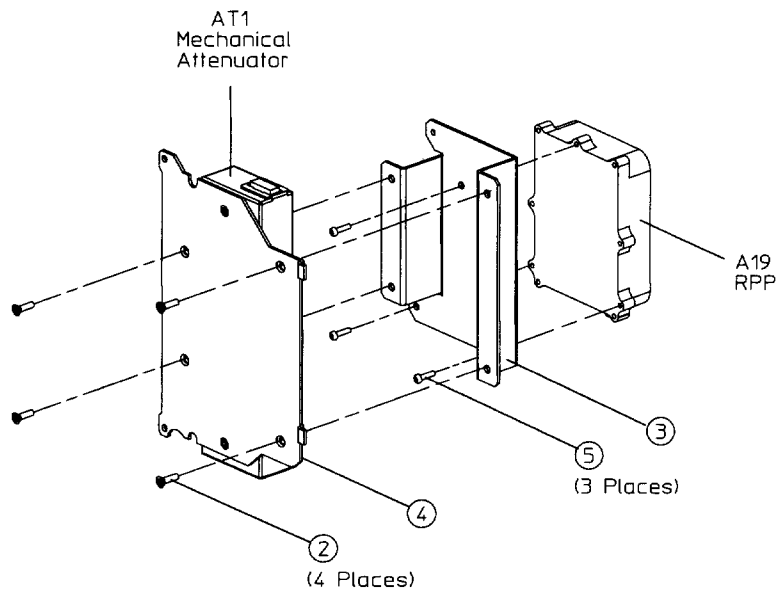

sk739b

A20 Downconverter

Tools Required

- T-10 TORX screwdriver
- 5/16" open-end wrench

Removal

1. Remove the instrument cover. (Refer to the "Instrument Cover" replacement procedure on page 5-64.)
2. Remove the top cover by removing the 11 screws that secure it.
3. Disconnect W31, W32, W33, and W34 from the downconverter assembly (A20). (See Figure 5-22.)
4. Remove the two T-10 TORX screws (item 1) holding the assembly to the chassis.
5. Slide the assembly out and up to remove.

Replacement

1. Reverse the removal procedure and do the following:
 - Torque all T-10 TORX screws to 9 in-lbs.
 - Torque all semi-rigid coaxial line connectors to 9 in-lbs.

Figure 5-22 A20 Downconverter

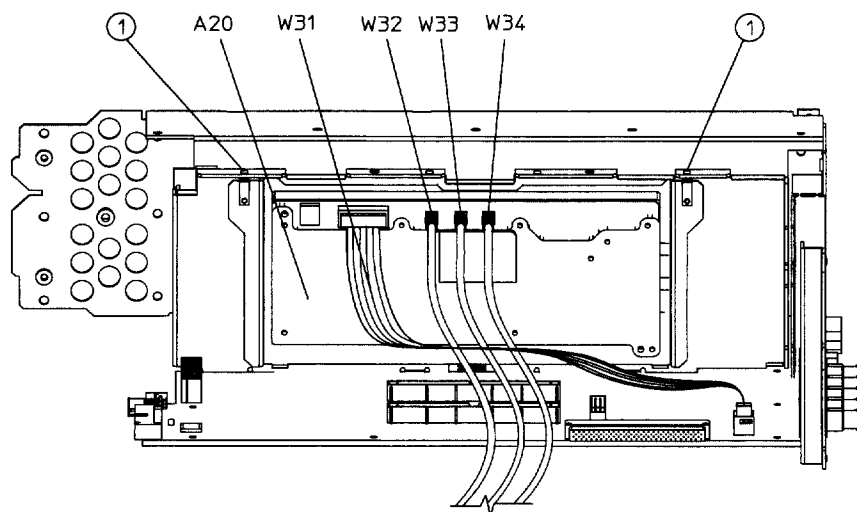

sk7141b

A22 YIG Driver

Tools Required

- T-10 TORX screwdriver
- 5/16" open-end wrench

Removal

1. Remove the instrument cover. (Refer to the "Instrument Cover" replacement procedure on page 5-64.)
2. Remove the top cover by removing the 11 screws that secure it.
3. Disconnect W35, W36, W37, W39, and W40 from the YIG driver assembly (A22). (See Figure 5-23.)
4. Remove the two T-10 TORX screws (item 1) holding the assembly to the chassis.
5. Slide the assembly out and up to remove.

Replacement

1. Reverse the removal procedure and do the following:
 - Torque all T-10 TORX screws to 9 in-lbs.
 - Torque all semi-rigid coaxial line connectors to 9 in-lbs.

Figure 5-23 A22 YIG Driver

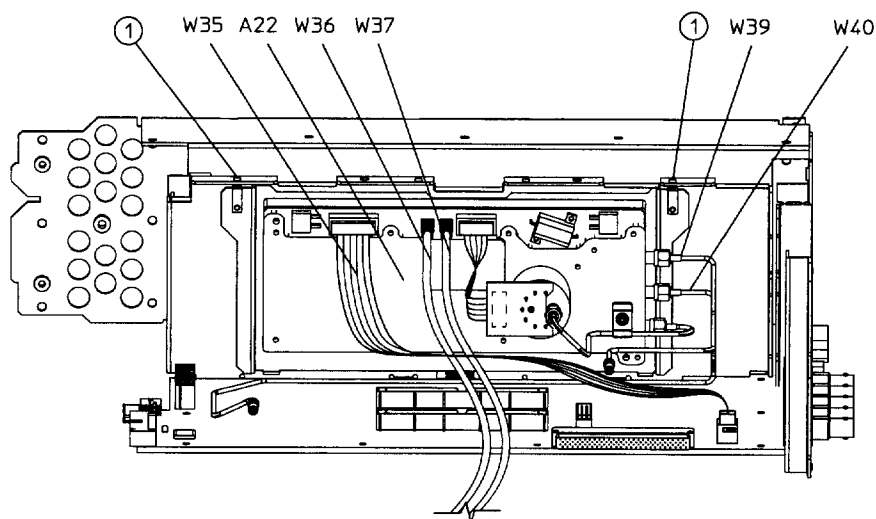

sk7140b

A25 Pulse Modulator

Tools Required

- T-10 TORX screwdriver
- 5/16" open-end wrench

Removal

1. Remove the instrument cover. (Refer to the "Instrument Cover" replacement procedure on page 5-64.)
2. Remove the top cover by removing the 11 screws that secure it.
3. Disconnect W45, W46, and W47 from the pulse modulator assembly (A25). (See Figure 5-24.)
4. Disconnect A25W1 from the CPU/motherboard (A14).
5. Remove the two screws (item 1) holding the pulse modulator assembly to the electronic attenuator assembly (AT1).
6. Slide the assembly out and up to remove.
7. Remove the two screws (item 2 in Figure 5-25) that attach the bracket (item 3) to the pulse modulator.

Replacement

1. Reverse the removal procedure and do the following:
 - Torque all screws to 9 in-lbs.
 - Torque all semi-rigid cables to 9 in-lbs.

Figure 5-24 A25 Pulse Modulator (1 of 2)

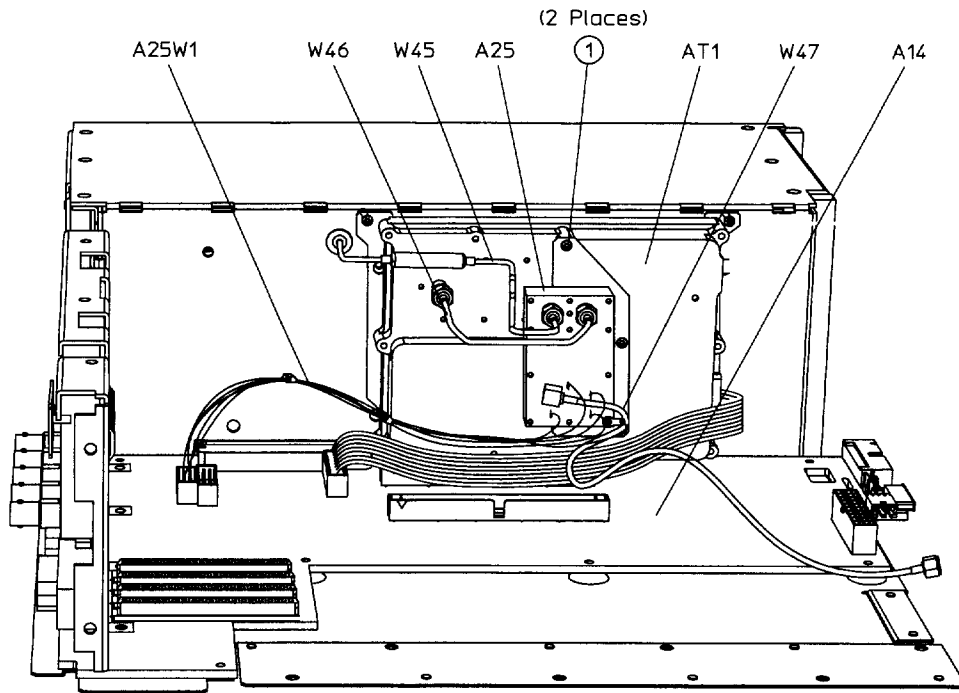

sk7142b

Figure 5-25 A25 Pulse Modulator (2 of 2)

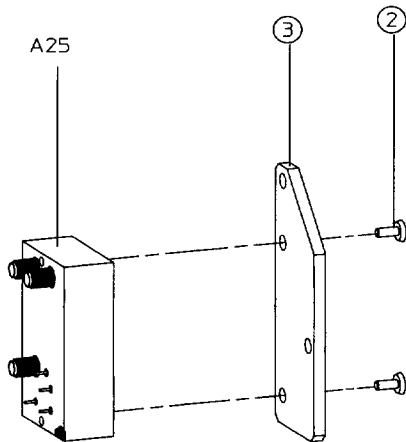

sk7155b

A25 Pulse Modulator (with Option UNB)

Tools Required

- T-10 TORX screwdriver
- 5/16" open-end wrench

Removal

1. Remove the instrument cover. (Refer to the "Instrument Cover" replacement procedure on page 5-64.)
2. Remove the top cover by removing the 11 screws that secure it.
3. Disconnect W45 and W47 from the pulse modulator (A25) and A25W1 from the CPU/motherboard (A14). (See Figure 5-26.)
4. Disconnect A19W1 from the CPU/motherboard.
5. Disconnect W9 from the RPP (A19).
6. Disconnect W13 from the CPU/motherboard.
7. Remove the two screws (item 1) that attach the attenuator/RPP/pulse assembly to the instrument chassis.
8. Tilt the assembly away from the chassis wall, then carefully lift it out of the instrument.

NOTE There are two hinged tabs at the bottom of the attenuator/RPP/pulse assembly that fit into slots in the instrument chassis. Therefore, it is necessary to tilt the assembly away from the chassis wall so that the tabs can be guided out of the slots.

9. Disconnect W20 from the RPP and the mechanical attenuator (AT1).
10. Disconnect W46 from the pulse modulator and the mechanical attenuator.
11. Remove the four screws (item 2 in Figure 5-27) that attach the RPP bracket (item 3) to the attenuator bracket (item 4).
12. Remove the two screws (item 5) that attach the RPP bracket to the pulse modulator.

Replacement

1. Reverse the removal procedure and do the following:
 - When reinstalling the attenuator/RPP/pulse assembly, remember to insert its hinged tabs into the slots located at the base of the chassis wall on which the assembly will be mounted.
 - Torque all semi-rigid cables to 9 in-lbs.
 - Torque all screws to 9 in-lbs.

Figure 5-26 A25 Pulse Modulator (with Option UNB) (1 of 2)

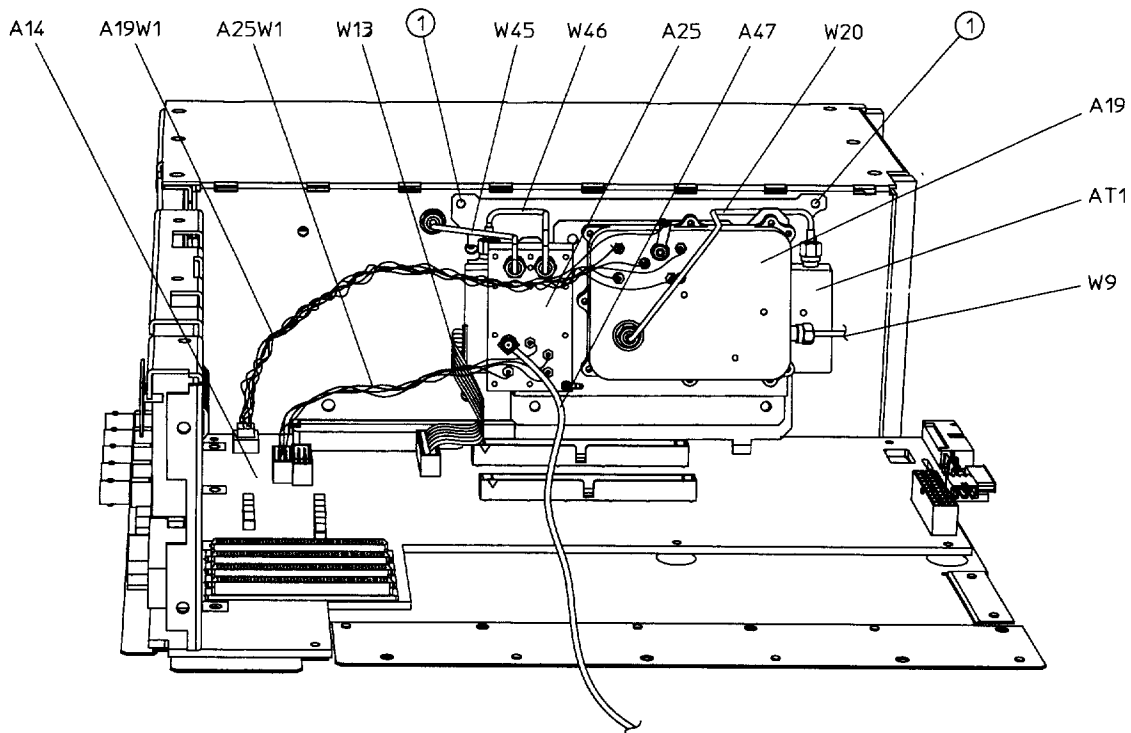

sk7153b

Figure 5-27 A25 Pulse Modulator (with Option UNB) (2 of 2)

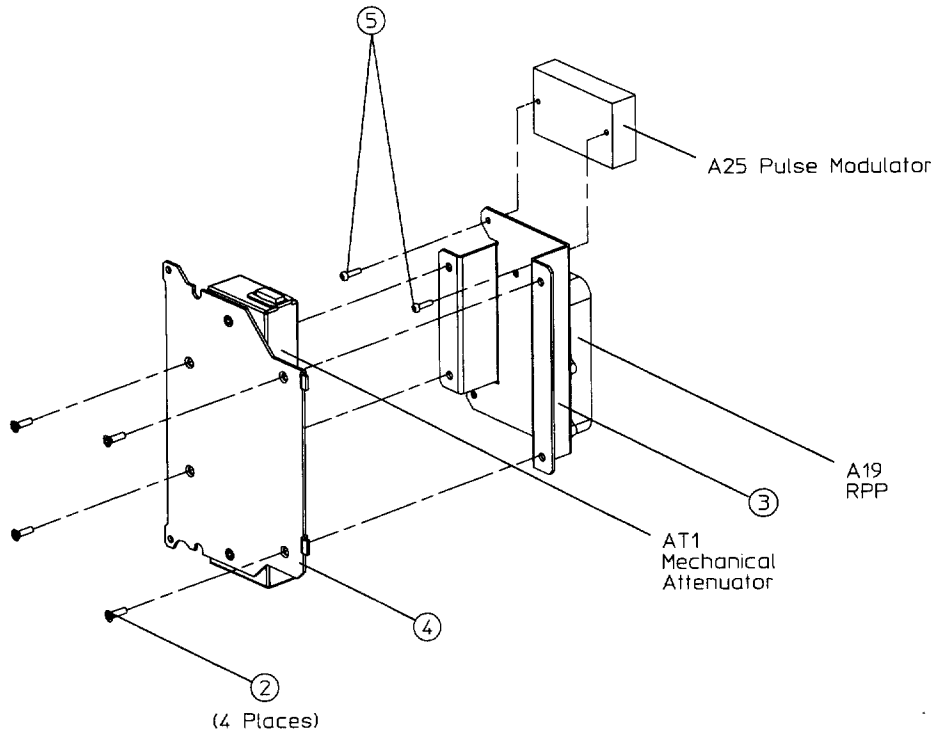

sk7154b

AT1 Electronic Attenuator/RPP

Tools Required

- T-10 TORX screwdriver
- 5/16-inch open-end wrench

Removal

1. Remove the instrument cover. (Refer to the “Instrument Cover” replacement procedure on page 5-64.)
2. Remove the top cover by removing the 11 screws that secure it.
3. If you have Option 1E6, remove the pulse modulator assembly (A25). (Refer to the “A25 Pulse Modulator” replacement procedure on page 5-41.)
4. Disconnect W9, W13, and W14 from the electronic attenuator/RPP (AT1). (See Figure 5-28.)
5. Remove the two screws (item 1) that attach the attenuator/RPP to the instrument chassis.
6. Tilt the attenuator/RPP away from the chassis wall, then carefully lift it out of the instrument.

NOTE There are two hinged tabs at the bottom of the attenuator/RPP that fit into slots in the instrument chassis. Therefore, it is necessary to tilt the attenuator/RPP away from the chassis wall so that the tabs can be guided out of the slots.

Replacement

1. Reverse the removal procedure and do the following:
 - When reinstalling the electronic attenuator/RPP (AT1), remember to insert its hinged tabs into the slots located at the base of the chassis wall on which the attenuator/RPP will be mounted.
 - Torque W9 and W14 to 9 in-lbs.
 - Torque the two T-10 TORX screws to 9 in-lbs.

Figure 5-28 AT1 Electronic Attenuator/RPP

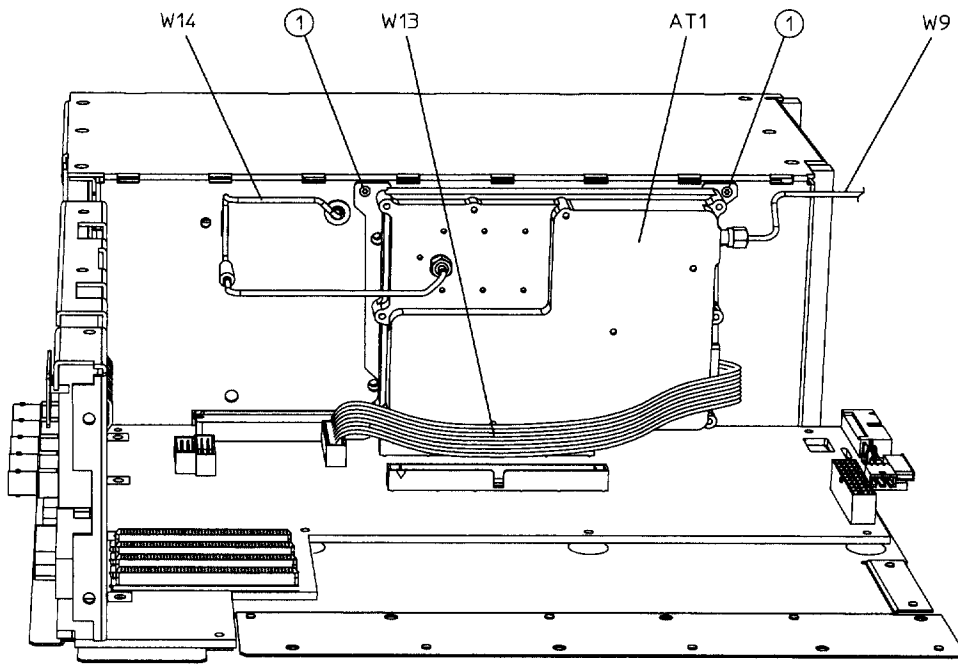

sk741b

AT1 Mechanical Attenuator

Tools Required

- T-10 TORX screwdriver
- 5/16-inch open-end wrench

Removal

1. Remove the instrument cover. (Refer to the “Instrument Cover” replacement procedure on page 5-64.)
2. Remove the top cover by removing the 11 screws that secure it.
3. If you have Option 1E6, disconnect W45 and W47 from the pulse modulator (A25) and A25W1 from the CPU/motherboard (A14). (See Figure 5-29.)
If you *do not* have Option 1E6, disconnect W14 from the mechanical attenuator (AT1). (See Figure 5-30.)
4. Disconnect A19W1 from the CPU/motherboard.
5. Disconnect W9 from the RPP (A19).
6. Disconnect W13 from the CPU/motherboard.
7. Remove the two screws (item 1) that attach the attenuator/RPP assembly to the instrument chassis.
8. Tilt the assembly away from the chassis wall, then carefully lift it out of the instrument.

NOTE There are two hinged tabs at the bottom of the attenuator/RPP assembly that fit into slots in the instrument chassis. Therefore, it is necessary to tilt the assembly away from the chassis wall so that the tabs can be guided out of the slots.

9. Disconnect W20 from the RPP and the mechanical attenuator (AT1).
10. If you have Option 1E6, disconnect W46 from the pulse modulator and the mechanical attenuator. (See Figure 5-29.)
11. Remove the four screws (item 2 in Figure 5-31) that attach the RPP bracket (item 3) to the attenuator bracket (item 4).
12. Remove the two screws (item 5) that attach the attenuator bracket to the mechanical attenuator (AT1).

Replacement

1. Reverse the removal procedure and do the following:
 - When reinstalling the electronic attenuator/RPP assembly, remember to insert its hinged tabs into the slots located at the base of the chassis wall on which the assembly will be mounted.
 - Torque all semi-rigid cables to 9 in-lbs.
 - Torque all screws to 9 in-lbs.

Figure 5-29 AT1 Mechanical Attenuator (1 of 3)

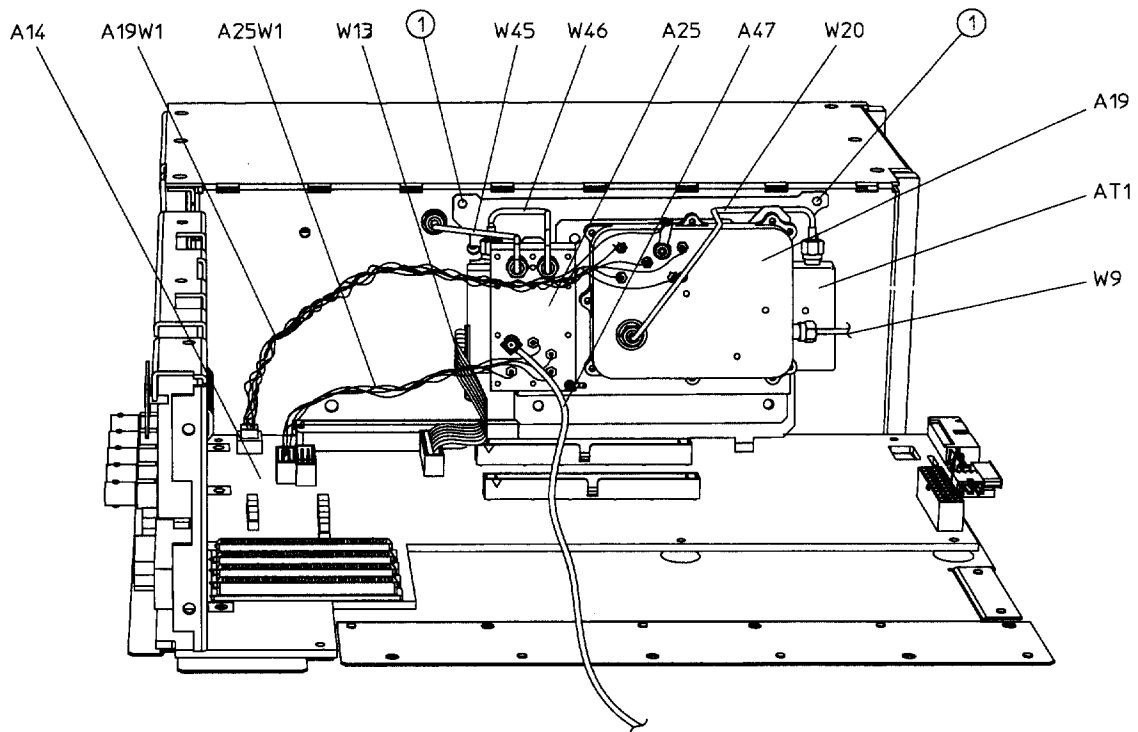

sk7153b

Figure 5-30 AT1 Mechanical Attenuator (2 of 3)

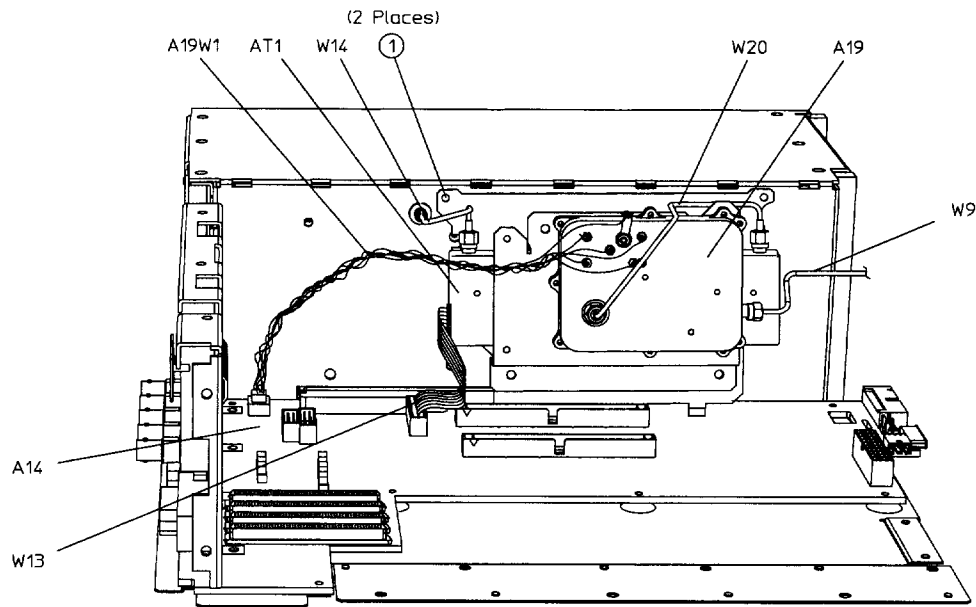

sk738b

Figure 5-31 AT1 Mechanical Attenuator (3 of 3)

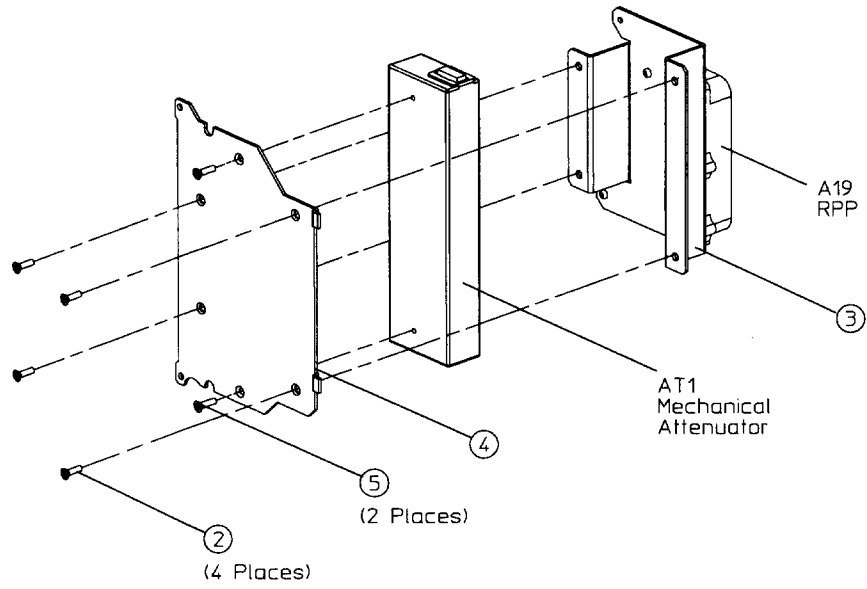

sk740b

B1 Small Fan

Tools Required

- knife blade (or equivalent)
- long nose pliers

Removal

NOTE It is best to attempt this procedure without removing the front panel assembly. If the front panel assembly is removed, you will be required to perform time-consuming “Power Level Accuracy” verification tests and adjustments.

1. Remove the instrument cover. (Refer to the “Instrument Cover” replacement procedure on page 5-64.)
2. Disconnect B1W1 from the CPU/motherboard (A14). (See Figure 5-32.)
3. Remove the four plastic rivets (item 1) that attach the fan assembly (B1) to the instrument chassis. Use a knife blade (or equivalent) to pry up the head of the plunger portion of the rivet. Once the head of the plunger is adequately raised, use a pair of long nose pliers to remove the rivet. Be careful not to damage the rivets with the blade.

NOTE The plastic rivets consist of two pieces: a plunger and a sheath. Ensure both parts are removed.

4. Remove the fan assembly.

Replacement

1. Reverse the removal procedure. When reinserting the plastic rivets, the sheath must be fully seated in the fan assembly before the plunger can be depressed.

Figure 5-32 B1 Small Fan

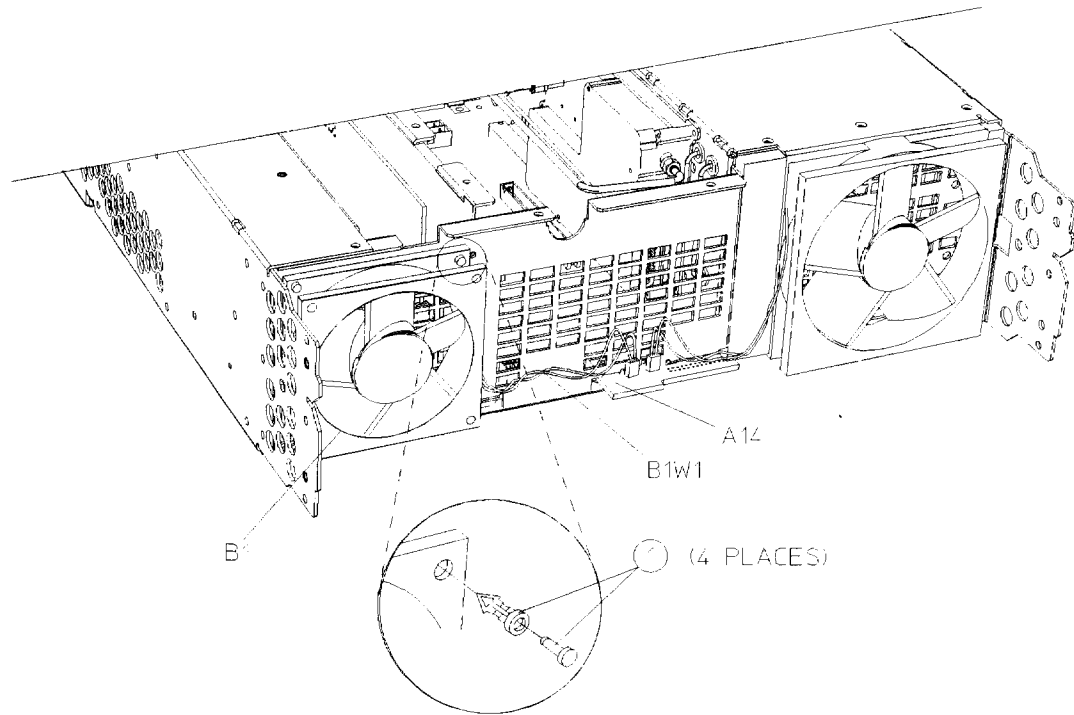

sk727c

B2 Large Fan

Tools Required

- 1/4-inch open-end wrench
- Modified T-10 TORX bit (part number 8710-1637)

Bit Modification. The hexagonal head at the end of the TORX bit must be removed so that the total length of the bit is approximately 1.5 inches (see Figure 5-33). A hexagonal portion of the bit will remain for use with a wrench. The shortened bit will now fit between the fan assembly and the front panel assembly.

Figure 5-33 Modified Bit

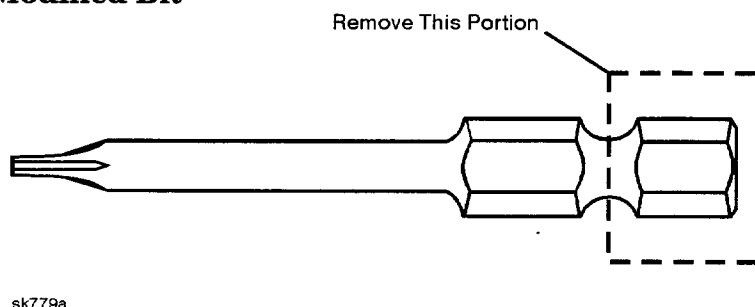

Removal

NOTE It is best to attempt this procedure without removing the front panel assembly. If the front panel assembly is removed, you will be required to perform time-consuming “Power Level Accuracy” verification tests and adjustments.

1. Remove the instrument cover. (Refer to the “Instrument Cover” replacement procedure on page 5-64.)
2. Disconnect B2W1 from the CPU/motherboard (A14). (See Figure 5-34.)
3. Remove the four screws (item 1) that attach the fan assembly (B2) to the instrument chassis.
4. Remove the fan assembly.

Replacement

1. Reverse the removal procedure and torque the T-10 TORX screws to 9 in-lbs.

Figure 5-34 B2 Large Fan

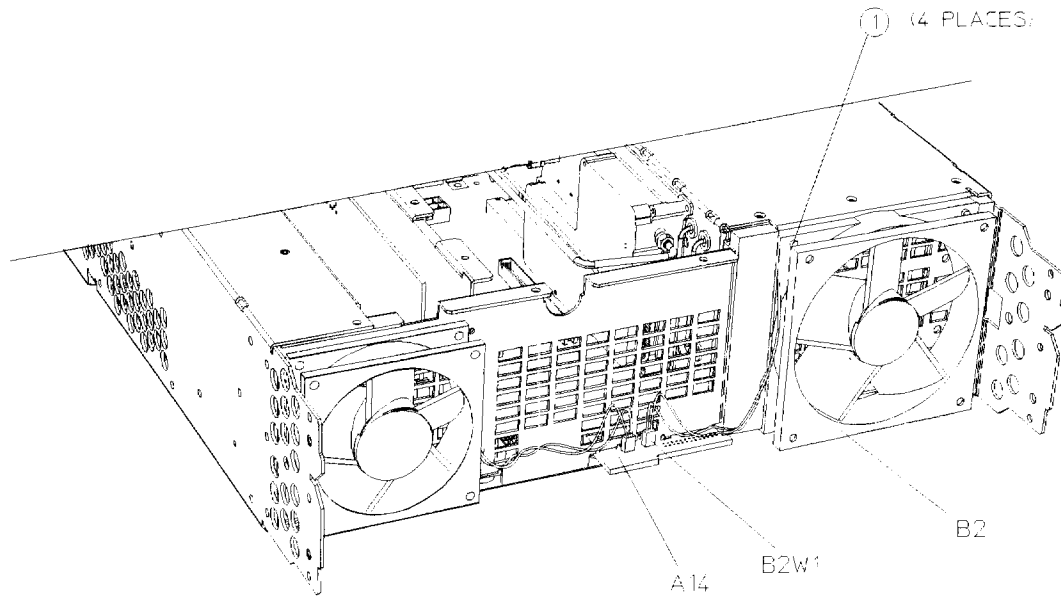

sk726a

Daughterboard Card Cage Boards

Use this procedure to remove any of the following assemblies: (See Figure 5-35.)

- Output Board (A9)
- Reference Board (A11)
- Synthesizer/Doubler Board (A12)
- Sampler Board (A23)
- Frac-N/Divider Board (A24)

Tools Required

- T-8 TORX screwdriver

Removal

1. Remove the instrument cover. (Refer to the “Instrument Cover” replacement procedure on page 5-64.)
2. Remove the right-side cover by removing the four screws that attach it to the instrument chassis.
3. Simultaneously lift the left and right extractors (item 1) on the board you want to remove.
4. Remove the board from the card cage slot.

Replacement

1. Reverse the removal procedure and torque all T-8 TORX screws to 9 in-lbs.

Figure 5-35 Daughterboard Card Cage Boards

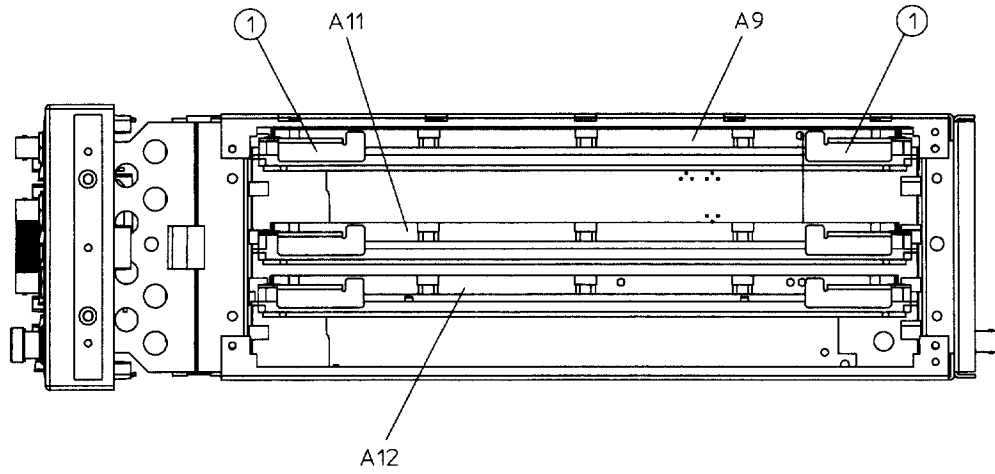

ESG-A and ESG-D Series

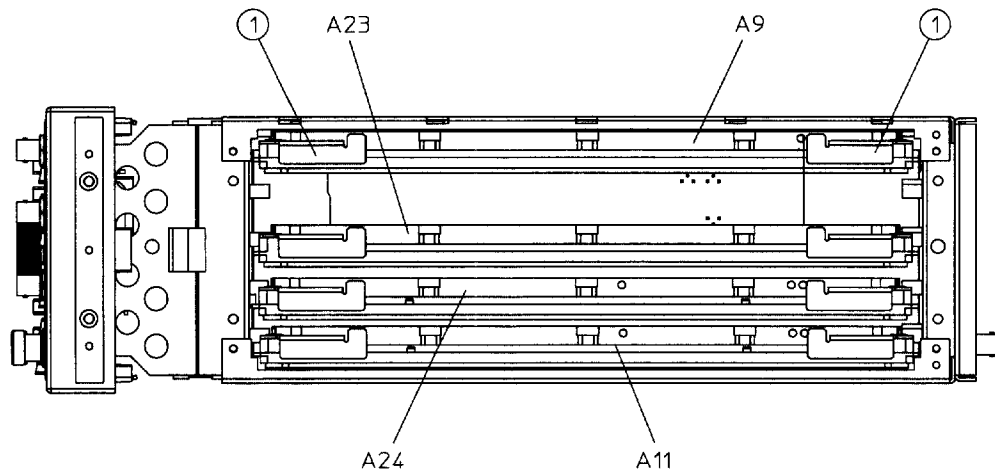

ESG-AP and ESG-DP Series

sk7118b

Digital Card Cage Boards

Use this procedure to remove any of the following assemblies: (See Figure 5-36.)

- A5 Dual Arbitrary Waveform Generator Board
- A6 Bit Error Rate Test Board
- A7 Baseband Generator Board
- A8 Data Generator Board
- A21 Demodulator Board

Tools Required

- T-10 TORX screwdriver
- long nose pliers

Removal

1. Remove the instrument cover. (Refer to the “Instrument Cover” replacement procedure on page 5-64.)
2. Remove the top cover by removing the 11 screws that secure it.
3. Disconnect all of the cables and harnesses from the board.
4. Pull up on the board to remove it from the CPU/motherboard connector.

Replacement

1. Reverse the removal procedure and do the following:
 - Refer to replaceable parts chapter for your signal generator model to verify that the cables are reconnected in the correct locations. (Refer to Chapter 3 for the ESG-A and ESG-D series, refer to Chapter 4 for the ESG-AP and ESG-DP series.)
 - Torque all T-10 TORX screws to 9 in-lbs.

Figure 5-36 Digital Card Cage Boards

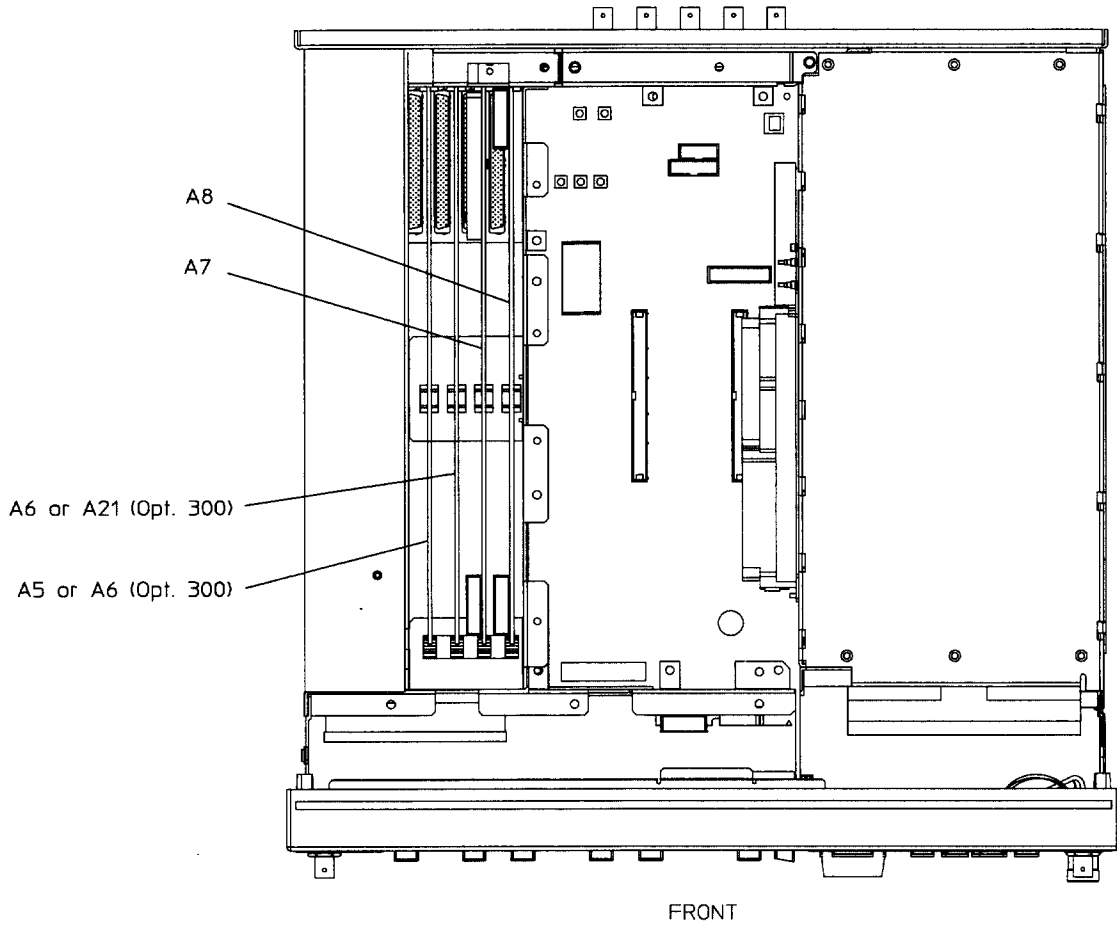

sk7134b

Front Panel

Tools Required

- T-10 TORX screwdriver
- T-15 TORX screwdriver
- 5/16-inch open-end wrench
- long nose pliers (used for disconnecting cables from the daughterboard)

Removal

1. Remove the instrument cover. (Refer to the “Instrument Cover” replacement procedure on page 5-64.)
2. Remove the top cover by removing the 11 screws that secure it.
3. Disconnect A1W1, A3W1, and W10 from the CPU/motherboard (A14). (See Figure 5-37.) To disconnect W10, you must first unlock the CPU/motherboard connector by pulling out the locking mechanism (much like pulling out a drawer).
4. Disconnect all remaining front panel cables (if any) from the various assemblies within the signal generator.

NOTE Figure 5-37 represents an Option UN3 or UN4.

Figure 5-37 Front Panel (1 of 2)

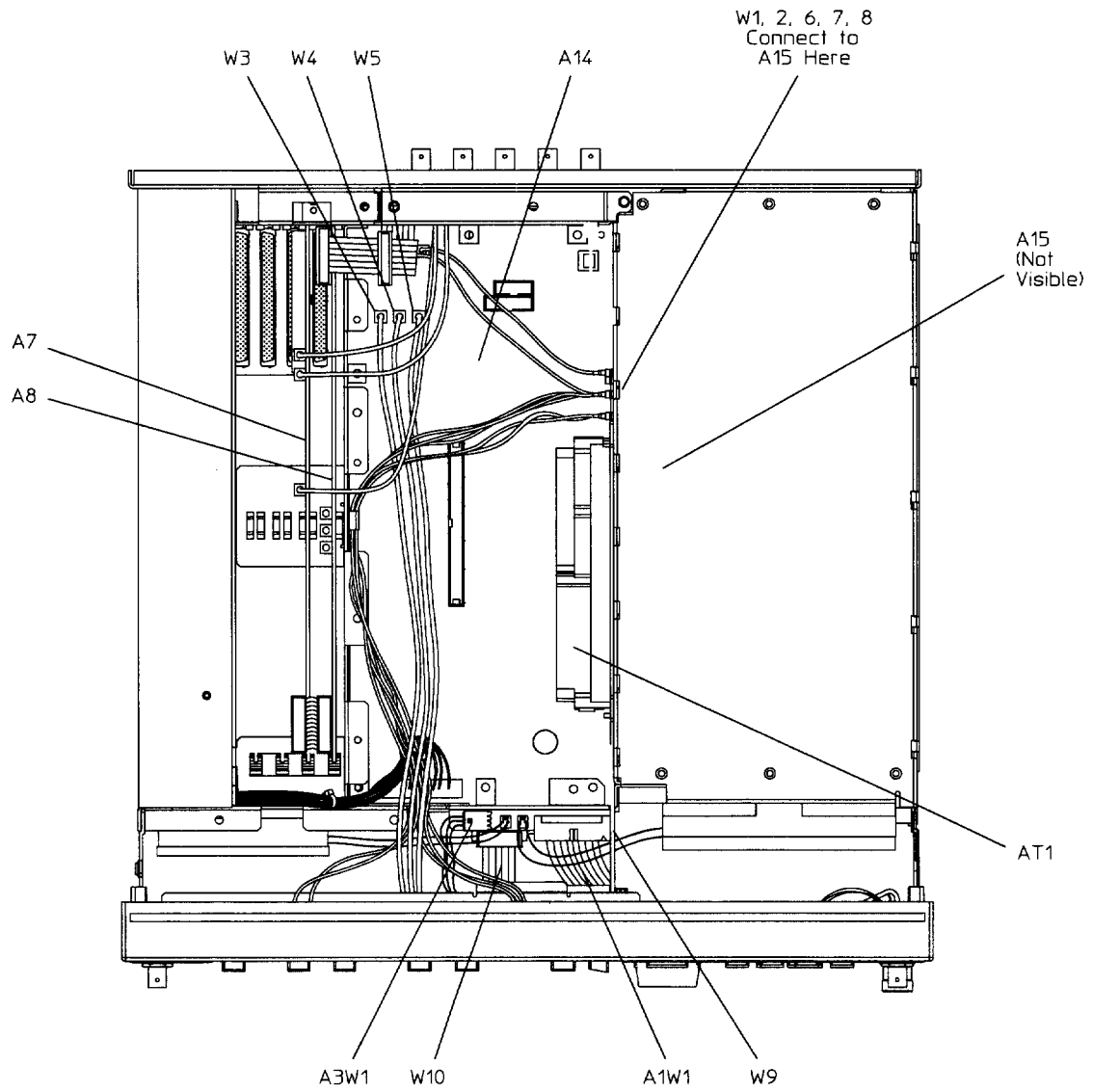

sk7133b

5. Carefully peel off the side trim (item 1 in Figure 5-38) from the sides of the front panel assembly (item 2).
6. Remove the four screws (item 3) that attach the front panel assembly to the instrument chassis.
7. Pull the front panel assembly away from the instrument chassis.

Replacement

1. Reverse the removal procedure and do the following:
 - Refer to replaceable parts chapter for your signal generator model to verify that the cables are reconnected in the correct locations. (Refer to Chapter 3 for the ESG-A and ESG-D series, refer to Chapter 4 for the ESG-AP and ESG-DP series.)
 - To reconnect W10 to its CPU/motherboard connector do the following:
 - a. Ensure the CPU/motherboard connector is unlocked by pulling out the locking mechanism (much like pulling out a drawer).
 - b. Insert W10 into the connector, making sure the conductive contacts are facing up (the blue insulation should be facing down).
 - c. Lock the connector by pushing in on the locking mechanism.

NOTE Intermittent display problems may result if W10 is not connected correctly.

- Torque W9 to 9 in-lbs.
- Torque all T-10 TORX screws to 9 in-lbs.
- Torque all T-15 TORX screws to 21 in-lbs.

Figure 5-38 Front Panel (2 of 2)

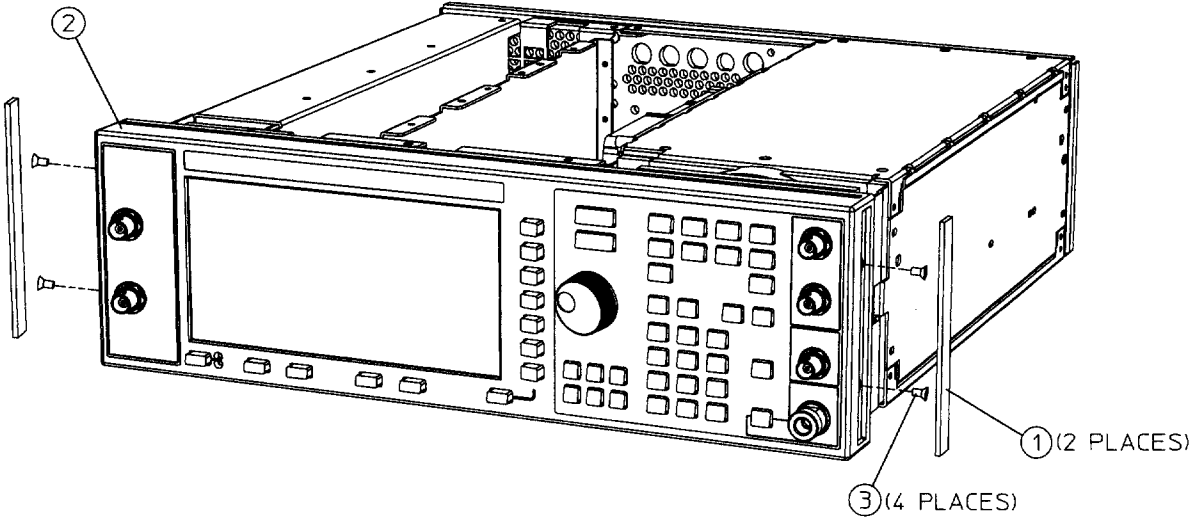

sk723b

Instrument Cover

Tools Required

- T-15 TORX screwdriver
- T-20 TORX screwdriver

Removal

1. Remove the two strap handles (item 1 in Figure 5-39) from each side of the signal generator by loosening the two screws (item 2) on each handle.
2. Remove the four bottom feet (item 3).
3. Remove the four rear feet (item 4) from the signal generator by removing the four screws (item 5) that secure them.
4. Slide the instrument cover (item 6) off the back of the signal generator.

Replacement

1. Reverse the removal procedure and do the following:
 - Torque the rear feet screws (item 4) to 21 in-lbs.
 - Torque the strap handle screws (item 2) to 21 in-lbs.

Figure 5-39 Instrument Cover

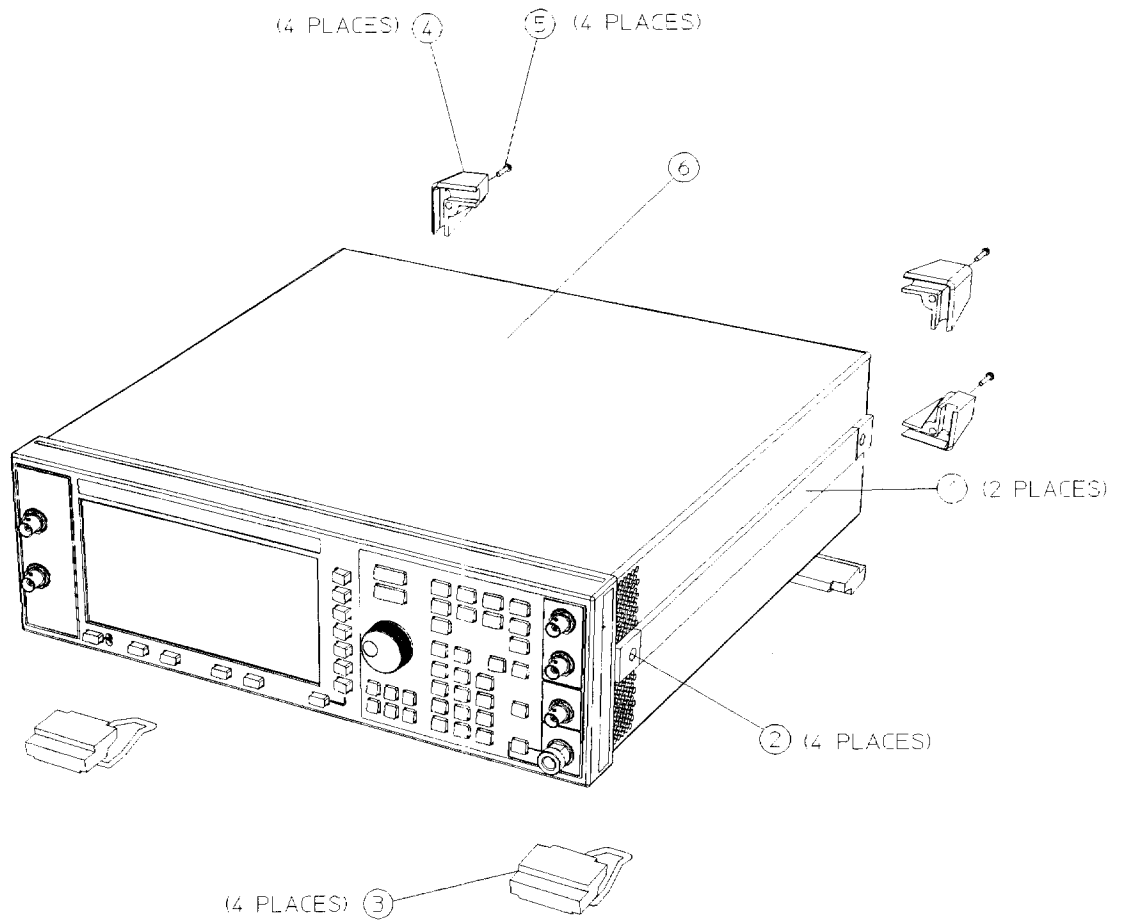

sk7104a

Rear Panel

Tools Required

- T-10 TORX screwdriver
- 3/16-inch wrench or nut driver
- 9/32-inch wrench or nut driver
- 5/16-inch open-end wrench
- 5/8-inch wrench or nut driver
- long nose pliers

Removal

1. Remove the instrument cover. (Refer to the “Instrument Cover” replacement procedure on page 5-64.)
2. Remove the top cover by removing the 11 screws that secure it.
3. Remove the bottom cover by removing the 15 screws that secure it.
4. Disconnect A16W1 from the power supply (A4). (See Figure 5-40.) A16W1 can be accessed through an opening on the bottom of the power supply shield (item 1).
5. Disconnect all remaining rear panel cables (if any) from the various assemblies within the signal generator.

NOTE Figure 5-40 represents an Option UN7/UND.

Figure 5-40 Rear Panel (1 of 2)

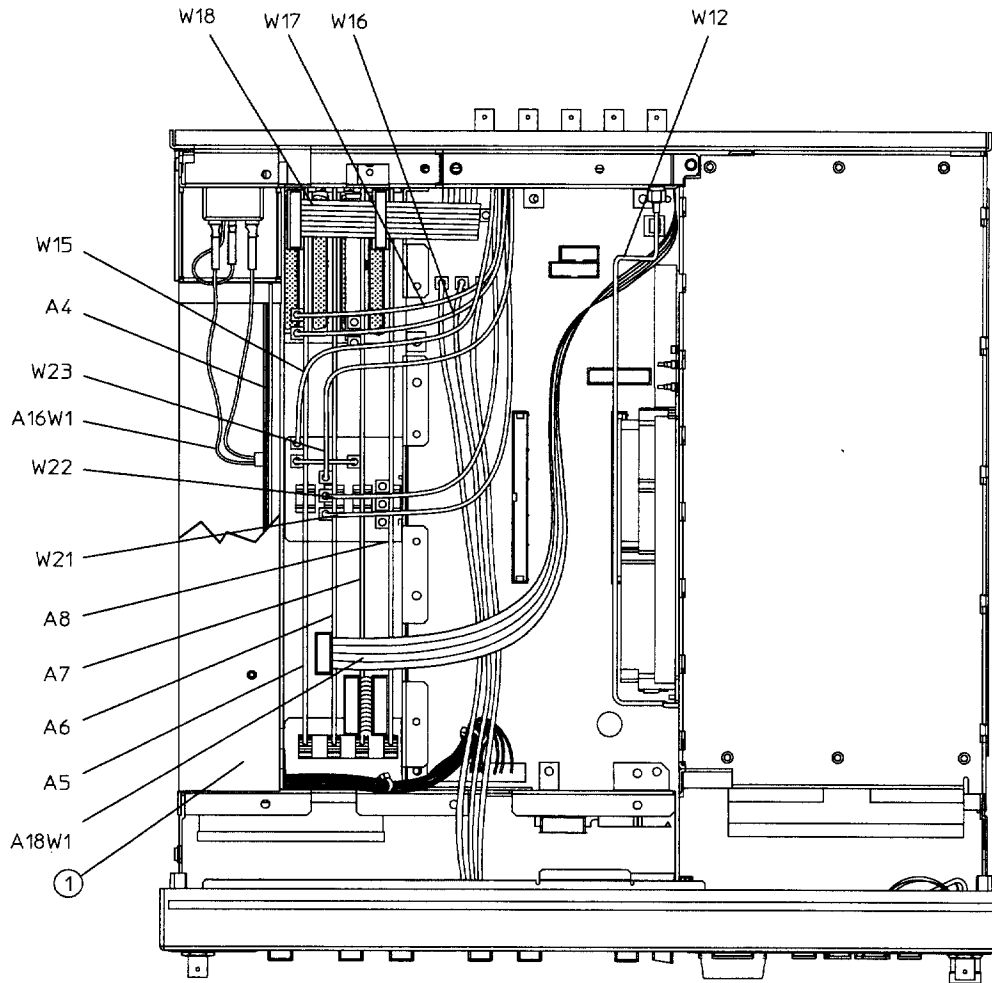

sk7131b

6. Remove the nuts and washers securing the five BNC connectors (item 1 in Figure 5-41) at the base of the rear panel.
7. Remove the hex screws and washers that secure the AUXILARY INTERFACE (item 2) and the GPIB connector (item 3) to the rear panel.
8. Remove the 10 screws (item 4) that secure the rear panel to the instrument chassis. Do not remove the screw that secures the chain and cap for COHERENT CARRIER connector.
9. Pull the rear panel assembly away from the instrument chassis.

Replacement

1. Reverse the removal procedure and do the following:
 - Torque all T-10 TORX screws to 9 in-lbs.
 - Torque the AUXILARY INTERFACE hex screws to 6 in-lbs.
 - Torque the GPIB hex screws to 9 in-lbs.
 - Torque the five BNC connector nuts to 21 in-lbs.
 - Torque W12 to 9 in-lbs.
 - Refer to replaceable parts chapter for your signal generator model to verify that the cables are reconnected in the correct locations. (Refer to Chapter 3 for the ESG-A and ESG-D series, refer to Chapter 4 for the ESG-AP and ESG-DP series.)

Figure 5-41 Rear Panel (2 of 2)

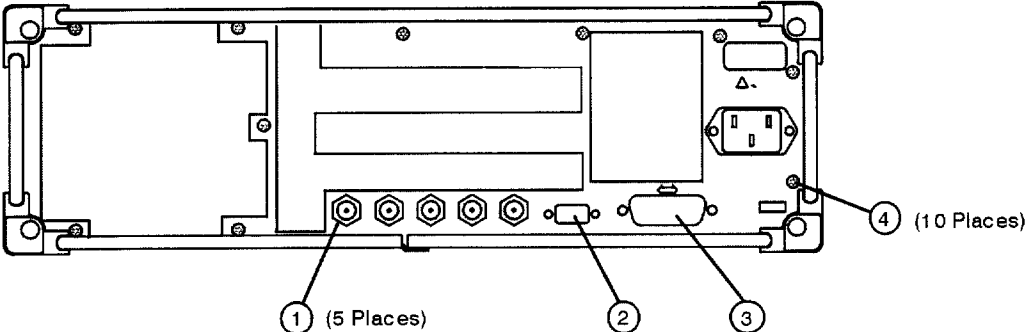

sk778a

Rear Panel (with Option 1EM)

Tools Required

- T-10 TORX screwdriver
- 3/16-inch wrench or nut driver
- 9/32-inch wrench or nut driver
- 5/8-inch wrench or nut driver
- long nose pliers

Removal

1. Remove the instrument cover. (Refer to the “Instrument Cover” replacement procedure on page 5-64.)
2. Remove the top cover by removing the 11 screws that secure it.
3. Remove the bottom cover by removing the 15 screws that secure it.
4. Disconnect A16W1 from the power supply (A4). (See Figure 5-42.) A16W1 can be accessed through an opening on the bottom of the power supply shield (item 1).
5. Disconnect all remaining rear panel cables from the various assemblies within the signal generator.

Figure 5-42 Rear Panel (with Option 1EM) (1 of 2)

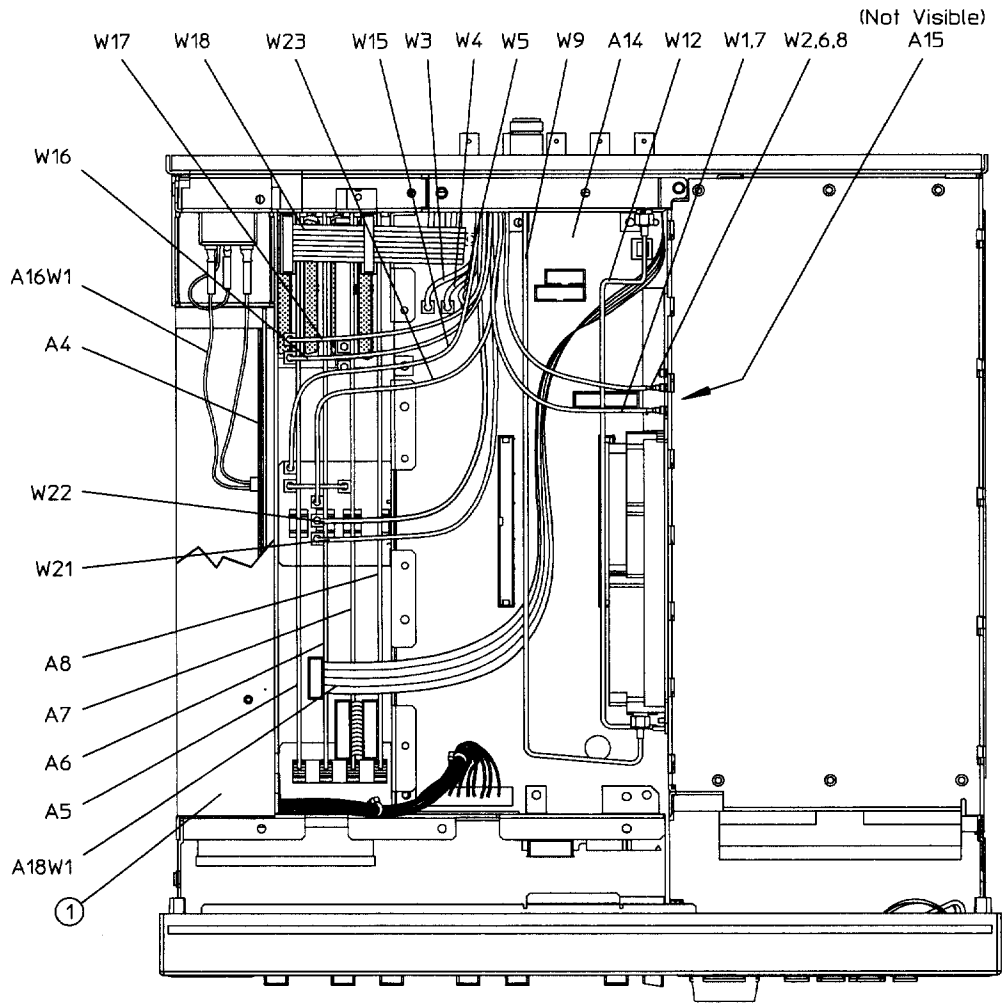

sk7130b

6. Remove the nuts and washers securing the five BNC connectors (item 1 in Figure 5-43) at the base of the rear panel.
7. Remove the hex screws and washers that secure the AUXILIARY INTERFACE (item 2) and the GPIB connector (item 3) to the rear panel.
8. Remove the 10 screws (item 4) that secure the rear panel to the instrument chassis.
9. Pull the rear panel assembly away from the instrument chassis.

Replacement

1. Reverse the removal procedure and do the following:
 - Torque all T-10 TORX screws to 9 in-lbs.
 - Torque the AUXILIARY INTERFACE hex screws to 6 in-lbs.
 - Torque the GPIB hex screws to 9 in-lbs.
 - Torque the five BNC connector nuts to 21 in-lbs.
 - Torque W9 and W12 to 9 in-lbs.
 - Refer to replaceable parts chapter for your signal generator model to verify that the cables are reconnected in the correct locations. (Refer to Chapter 3 for the ESG-A and ESG-D series, refer to Chapter 4 for the ESG-AP and ESG-DP series.)

Figure 5-43 Rear Panel (with Option 1EM) (2 of 2)

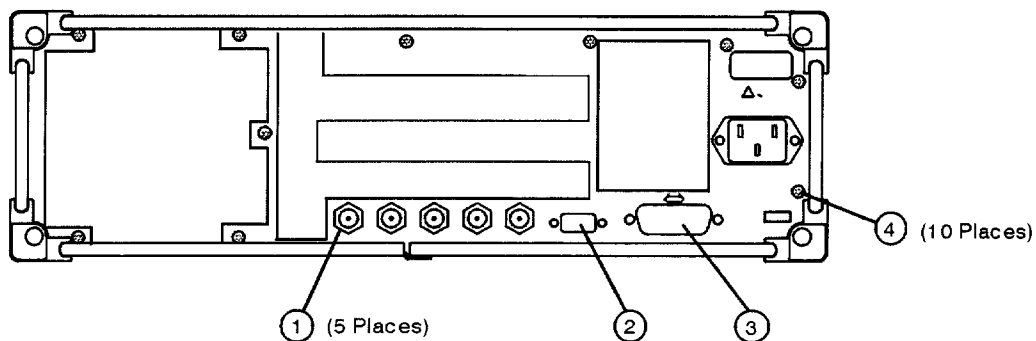

sk778a

Semi-Rigid Cables

Use this procedure to remove and replace semi-rigid cables that attach to the daughterboard card cage. If the cable you are removing/replacing does not attach to the daughterboard card cage, no special instruction is necessary other than step 3 in the “Replacement” section below.

Tools Required

- MILBAR 2R snap-ring pliers (used to remove snap rings from cable retainers)
- 5/16-inch open-end wrench

Removal

1. Remove all the daughterboard card cage boards to allow access to the instrument chassis cable connections. (Refer to the “Daughterboard Card Cage Boards” replacement procedure on page 5-56.)
2. Remove the snap ring (item 1 in Figure 5-44) from the cable retainer (item 2) of the cable you want to remove. The cable is now disconnected from the instrument chassis (item 3).
3. Disconnect the other end of the cable.

Replacement

1. If you’re installing a new cable, a *new* cable retainer (item 2) must first be attached to the end of the cable (item 4). Verify the cable retainer is correctly attached by listening for an audible “click” as you slide it over the end of the cable.
2. Insert the cable-retainer end of the cable assembly into the opening of the instrument chassis and then secure it with a snap ring.
3. Connect the other end of the cable. All semi-rigid cables should be torqued to 9 in-lbs.
4. Replace the daughterboard card cage boards.

Figure 5-44 Semi-Rigid Cables

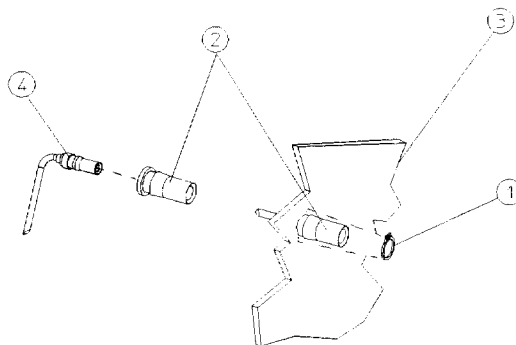

sk7129b

6 Post-Repair Procedures

This chapter lists the performance tests and adjustments that must be performed after an assembly has been replaced.

Performance Tests

The tables in this section list the performance tests that must be performed when a specific assembly is repaired or replaced. (Refer to the list below for the table that applies to your signal generator.) Except where noted, all tests are automated using software. For more information on performance tests, refer to the calibration guide.

For the ESG-A Series refer to Table 6-1 on page 6-3

For the ESG-D Series refer to Table 6-2 on page 6-4

For the ESG-AP Series refer to Table 6-3 on page 6-5

For the ESG-DP Series refer to Table 6-4 on page 6-6

Table 6-1 Performance Tests for the ESG-A Series

Performance Test	Repaired/Replaced Assembly															
	A1 Front Panel Bd	A2 Display	A2DS1 Lamp	A3 Inverter	A4 Power Supply	A9 Output Bd	A11 Reference Bd	A12 Synthesizer Bd	A14 Motherboard	A14BT1 Battery	A15 Daughterboard	A16 Line Module	A19 RPP	A25 Pulse Modulator	AT1 Elec Atten/RPP	AT1 Mech Atten
AM Frequency Response					•	•	•		•		•					
DCFM Frequency Offset					•		•	•	•	•						
FM Frequency Response					•		•	•	•		•					
Harmonics					•	•		•	•							
Internal AM Accuracy					•	•	•		•							
Internal AM Distortion					•	•	•		•							
Internal FM Accuracy					•		•	•	•							
Internal FM Distortion					•		•	•	•							
Nonharmonics					•	•	•	•	•							
Phase Modulation Accuracy					•		•	•	•							
Phase Modulation Distortion					•		•	•	•							
PM Frequency Response					•		•	•	•		•					
Power Level Accuracy	.1	.1	.1	•	•	•			•		•	.2	•	•	•	•
Pulse Modulation On/Off Ratio					•	•			•							
Residual FM					•		•	•	•		•					
Subharmonics					•	•		•	•							
Timebase Aging Rate ³					•		•		•							
Pulse Rise/Fall Time (Opt. 1E6)									•					•		

1. Perform this test only if you *do not* have Option 1EM.
2. Perform this test only if you have Option 1EM.
3. This test must be performed manually.

Table 6-2 Performance Tests for the ESG-D Series

Performance Test	Repaired/Replaced Assembly																							
	A1 Front Panel Bd	A2 Display	A2DS1 Lamp	A3 Inverter	A4 Power Supply	A5 Dual Arb Bd	A6 Bit Error Rate Bd	A7 Baseband Gen Bd	A8 Data Gen Bd	A9 Output Bd	A11 Reference Bd	A12 Synthesizer Bd	A14 Motherboard	A14BT1 Battery	A15 Daughterboard	A16 Line Module	A17 Rear Panel Bd	A18 BER Rear Pan Bd	A19 RPP	A20 Downconverter	A21 Demodulator Bd	AT1 Elec Atten/RPP	AT1 Mech Atten	
AM Frequency Response					*				*	*		*		*	*									
Burst Modulation On/Off Ratio					*				*	*		*		*	*									
DCFM Frequency Offset					*				*	*		*		*	*									
Digital Mod: Power Level Accuracy					*				*	*		*		*	*									
FM Frequency Response					*				*	*		*		*	*									
Harmonics					*				*	*		*		*	*				*					
Internal AM Accuracy					*				*	*		*		*	*									
Internal AM Distortion					*				*	*		*		*	*									
Internal FM Accuracy					*				*	*		*		*	*									
Internal FM Distortion					*				*	*		*		*	*									
Nonharmonics					*		*	*	*	*		*		*	*				*					
Phase Modulation Accuracy					*				*	*		*		*	*									
Phase Modulation Distortion					*				*	*		*		*	*									
PM Frequency Response					*				*	*		*		*	*									
Power Level Accuracy	.1	.1	.1	.1	*				*	*		*		*	*	.2	.2	.2	*			*	*	
Pulse Modulation On/Off Ratio					*				*	*		*		*	*									
Residual FM					*				*	*		*		*	*									
Subharmonics					*				*	*		*		*	*									
Timebase Aging Rate ³					*				*	*		*		*	*									
WCDMA (Opt. 100/H99)						*																		
CDMA2000 (Opt. 101)						*																		
GSM Loopback BER (Opt. 300)							*												*	*				
WCDMA ACP (Opt. H99 w/ H97 or H98)						*			*	*														
Digital Mod: Internal IQ Quality (Opt. UN3, UN4, UN8)					*		*	*	*	*		*	*											
CDMA Adjacent Ch Power (Opt. UN5)						*			*	*														
Verifying Bit Error Rate Test ⁴ (Opt. UN7)							*											*						
Custom IQ RF Mod Quality (Opt. UN8)								*	*	*														
Alternate Timeslot (Opt. UNA)								*	*	*													*	
Dual Arb Check (Opt. UND)						*																		

1. Perform this test only if you *do not* have Option 1EM.
2. Perform this test only if you have Option 1EM.
3. This test must be performed manually.
4. This is an operator's check, *not* a performance test. Refer to Chapter 1 of the *ESG Family Signal Generators Option UN7 Bit Error Rate Test Users's and Programming Guide* for instruction.

Table 6-3 Performance Tests for the ESG-AP Series

Performance Test	Repaired/Replaced Assembly																	
	A1 Front Panel Bd	A2 Display	A2DS1 Lamp	A3 Inverter	A4 Power Supply	A9 Output Bd	A11 Reference Bd	A14 Motherboard	A14BT1 Battery	A15 Daughterboard	A16 Line Module	A19 RPP	A22 YO Driver	A23 Sampler Bd	A24 Frac-N/Divider Bd	A25 Pulse Modulator	AT1 Elec Atten/RPP	AT1 Mech Atten
AM Frequency Response					•	•	•	•		•								
DCFM Frequency Offset					•		•	•	•	•					•			
FM Frequency Response					•		•	•		•			•		•			
Harmonics					•	•		•					•		•			
Internal AM Accuracy					•	•	•	•										
Internal AM Distortion					•	•	•	•										
Internal FM Accuracy					•		•	•					•		•			
Internal FM Distortion					•		•	•					•		•			
Nonharmonics					•	•	•	•					•	•	•			
Phase Modulation Accuracy					•		•	•					•		•			
Phase Modulation Distortion					•		•	•					•		•			
Phase Noise ³					•		•						•	•	•			
PM Frequency Response					•		•	•					•		•			
Power Level Accuracy	•1	•1	•1	•	•	•		•		•	•2	•	•		•	•	•	•
Pulse Modulation On/Off Ratio					•	•		•										
Residual FM ³					•	•	•						•	•	•			
Timebase Aging Rate ³					•		•	•										
Pulse Rise/Fall Time (Opt. 1E6)																•		

1. Perform this test only if you *do not* have Option 1EM.
2. Perform this test only if you have Option 1EM.
3. This test must be performed manually.

Table 6-4 Performance Tests for the ESG-DP Series

Performance Test	Repaired/Replaced Assembly																							
	A1 Front Panel Bd	A2 Display	A2DS1 Lamp	A3 Inverter	A4 Power Supply	A5 Dual Arb Bd	A6 Bit Error Rate Bd	A7 Baseband Gen Bd	A8 Data Gen Bd	A9 Output Bd	A11 Reference Bd	A14 Motherboard	A14BT1 Battery	A15 Daughterboard	A16 Line Module	A17 Rear Panel Bd	A18 BER Rear Pan Bd	A19 RPP	A22 YO Driver	A23 Sampler Bd	A24 Frac-N/Divider Bd	AT1 Elec Atten/RPP	AT1 Mech Atten	
AM Frequency Response					•					•	•	•		•										
Burst Modulation On/Off Ratio					•					•	•	•		•										
DCFM Frequency Offset					•						•	•	•						•			•		
Digital Mod: Power Level Accuracy					•					•		•												
FM Frequency Response					•						•	•		•						•			•	
Harmonics					•					•	•	•								•			•	
Internal AM Accuracy					•					•	•	•												
Internal AM Distortion					•					•	•	•												
Internal FM Accuracy					•						•	•								•			•	
Internal FM Distortion					•						•	•								•			•	
Nonharmonics					•			•	•	•	•	•								•		•		
Phase Modulation Accuracy					•						•	•								•			•	
Phase Modulation Distortion					•						•	•								•			•	
Phase Noise ³					•				•	•	•	•		•						•	•	•		
PM Frequency Response					•						•	•								•			•	
Power Level Accuracy	•1	•1	•1	•1	•					•		•		•	•2	•2	•2	•	•			•	•	•
Pulse Modulation On/Off Ratio					•					•		•												
Residual FM ³					•				•	•	•	•		•						•	•	•		
Timebase Aging Rate ³					•						•	•												
WCDMA (Opt. 100/H99)						•																		
CDMA2000 (Opt. 101)						•																		
WCDMA ACP (Opt. H99 w/ H97 or H98))						•				•														
Digital Mod: Internal IQ Quality (Opt. UN3, UN4, UN8)					•			•	•	•		•											•	
CDMA Adjacent Ch Power (Opt. UN5)						•				•														
Verifying Bit Error Rate Test ⁴ (Opt. UN7)							•										•							
Custom IQ RF Mod Quality (Opt. UN8)								•	•	•														
Alternate Timeslot (Opt. UNA)								•	•	•													•	
Dual Arb Check (Opt. UND)						•																		

1. Perform this test only if you *do not* have Option 1EM.
2. Perform this test only if you have Option 1EM.
3. This test must be performed manually.
4. This is an operator's check, *not* a performance test. Refer to Chapter 1 of the *ESG Family Signal Generators Option UN7 Bit Error Rate Test Users's and Programming Guide* for instruction.

Adjustments

The tables in this section list the adjustments that must be performed when a specific assembly is repaired or replaced. (Refer to the list below for the table that applies to your signal generator.) Except where noted, all adjustments are automated using software. For more information on adjustments, refer to the calibration guide.

For the ESG-A Series refer to Table 6-5 on page 6-8

For the ESG-D Series refer to Table 6-6 on page 6-9

For the ESG-AP Series refer to Table 6-7 on page 6-10

For the ESG-DP Series refer to Table 6-8 on page 6-11

Table 6-5 Adjustments for the ESG-A Series

Adjustment	Repaired/Replaced Assembly															
	A1 Front Panel Bd	A2 Display	A2DS1 Lamp	A3 Inverter	A4 Power Supply	A9 Output Bd	A11 Reference Bd	A12 Synthesizer Bd	A14 Motherboard	A14BT1 Battery	A15 Daughterboard	A16 Line Module	A19 RPP	A25 Pulse Modulator	AT1 Elec Atten/RPP	AT1 Mech Atten
ABUS ADC Cal					•				•							
Internal Source Cal					•		•		•							
VCO Bias Adjustment					•			•	•							
Lock Angle Adjustment					•			•	•							
Kv vs Frequency Cal					•			•	•							
AM Audio Path Offset					•	•	•		•							
Timebase DAC Cal					•		•		•							
FM Scale DAC Offset Cal					•		•		•							
FM Path Offset Cal					•		•		•							
FM In-band DAC Offset Cal					•		•		•							
FM Invert Amp Offset Cal					•		•		•							
FM1/2 Path Ratio Gain Cal					•		•		•							
Mod Source Relative Gain Cal					•		•		•							
FM Delay Pot Adjustment					•		•		•							
Wide BW PM Cal					•		•		•							
DCFM Cal					•		•		•	•						
Peak Detector Cal					•		•		•							
Burst Modulator Cal					•	•			•							
FM Out-of Band Cal					•		•		•							
LF Output Cal					•		•		•							
Prelevel Cal					•	•			•							
VBLO (Mixer Bias Cal)					•	•			•							
Gain Adjust					•	•			•				•		•	•
ALC Adjustments					•	•			•				•		•	•
Level Meter Cal					•	•			•							
ALC Mod Flatness Cal					•	•			•							
ALC Mod Driver Bias Cal					•	•			•							
AM Audio Path Gain Cal					•	•	•		•							
Power Level Accuracy	•1	•1	•1	•1	•	•			•		•		•	•	•	•

1. Perform this test only if you *do not* have Option 1EM.

Table 6-6 Adjustments for the ESG-D Series

Adjustment	Repaired/Replaced Assembly																							
	A1 Front Panel Bd	A2 Display	A2DS1 Lamp	A3 Inverter	A4 Power Supply	A5 Dual Arb Bd	A6 Bit Error Rate Bd	A7 Baseband Gen Bd	A8 Data Gen Bd	A9 Output Bd	A11 Reference Bd	A12 Synthesizer Bd	A14 Motherboard	A14BT1 Battery	A15 Daughterboard	A16 Line Module	A17 Rear Panel Bd	A18 BER Rear Pan Bd	A19 RPP	A20 Down Convertor	A21 Demodulator Bd	AT1 Elec Atten/RPP	AT1 Mech Atten	
ABUS ADC Cal					•								•											
Internal Source Cal					•						•		•											
VCO Bias Adjustment					•							•	•											
Lock Angle Adjustment					•							•	•											
Kv vs Frequency Cal					•							•	•											
AM Audio Path Offset					•					•	•		•											
Timebase DAC Cal					•						•		•											
FM Scale DAC Offset Cal					•						•	•	•											
FM Path Offset Cal					•						•	•	•											
FM In-band DAC Offset Cal					•						•	•	•											
FM Invert Amp Offset Cal					•						•	•	•											
FM1/2 Path Ratio Gain Cal					•						•	•	•											
Mod Source Relative Gain Cal					•						•	•	•											
FM Delay Pot Adjustment					•						•	•	•											
Wide BW PM Cal					•						•	•	•											
DCFM Cal					•						•	•	•	•										
Peak Detector Cal					•						•	•	•											
Burst Modulator Cal					•					•			•											
FM Out-of Band Cal					•						•	•	•											
LF Output Cal					•						•		•											
Burst Audio Path Cal					•					•	•		•											
Prelevel Cal					•						•		•											
VBLO (Mixer Bias Cal)					•						•		•											
I/Q Gain/Offset Quadrature					•		•			•		•	•											
Gain Adjust					•					•			•						•			•		•
ALC Adjustments					•					•			•						•			•		•
Level Meter Cal					•					•			•											
ALC Mod Flatness Cal					•					•			•											
ALC Mod Driver Bias Cal					•					•			•											
AM Audio Path Gain Cal					•					•	•		•											
Power Level Accuracy	•1	•1	•1	•1	•					•			•		•		•2		•			•		•

1. Perform this test only if you *do not* have Option 1EM.
2. Perform this test only if you have Option 1EM.

Table 6-7 Adjustments for the ESG-AP Series

Adjustment	Repaired/Replaced Assembly																	
	A1 Front Panel Bd	A2 Display	A2DS1 Lamp	A3 Inverter	A4 Power Supply	A9 Output Bd	A11 Reference Bd	A14 Motherboard	A14BT1 Battery	A15 Daughterboard	A16 Line Module	A19 RPP	A22 YO Driver	A23 Sampler Bd	A24 Frac-N/Divider Bd	A25 Pulse Modulator	AT1 Elec Atten/RPP	AT1 Mech Atten
ABUS ADC Cal					•		•											
Internal Source Cal					•		•	•										
VCO Bias Adjustment					•		•								•			
Lock Angle Adjustment					•			•							•			
Kv vs Frequency Cal					•			•							•			
AM Audio Path Offset					•	•	•	•										
Timebase DAC Cal					•		•	•										
FM Scale DAC Offset Cal					•		•	•							•			
FM Path Offset Cal					•		•	•							•			
FM In-band DAC Offset Cal					•		•	•							•			
FM Invert Amp Offset Cal					•		•	•							•			
FM1/2 Path Ratio Gain Cal					•		•	•							•			
Mod Source Relative Gain Cal					•		•	•							•			
FM Delay Pot Adjustment					•		•	•							•			
Wide BW PM Cal					•		•	•							•			
DCFM Cal					•		•	•	•						•			
Peak Detector Cal					•		•	•							•			
Burst Modulator Cal					•	•		•										
FM Out-of Band Cal					•		•	•							•			
LF Output Cal					•		•	•										
VBLO (Mixer Bias Cal)					•	•		•										
Gain Adjust					•	•		•				•					•	•
ALC Adjustments					•	•		•				•					•	•
Level Meter Cal					•	•		•										
ALC Mod Flatness Cal					•	•		•										
ALC Mod Driver Bias Cal					•	•		•										
AM Audio Path Gain Cal					•	•	•	•										
Power Level Accuracy	•1	•1	•1	•1	•	•		•		•		•	•			•	•	•
Pretune Calibration													•					
FM/PM YO Frequency Comp Calibration													•					
FM/PM OB Cal & Delay Pot													•					
LNF Gain Adjust					•	•												

1. Perform this test only if you *do not* have Option 1EM.

Table 6-8 Adjustments for the ESG-DP Series

Adjustment	Repaired/Replaced Assembly																							
	A1 Front Panel Bd	A2 Display	A2DS1 Lamp	A3 Inverter	A4 Power Supply	A5 Dual Arb Bd	A6 Bit Error Rate Bd	A7 Baseband Gen Bd	A8 Data Gen Bd	A9 Output Bd	A11 Reference Bd	A14 Motherboard	A14BT1 Battery	A15 Daughterboard	A16 Line Module	A17 Rear Panel Bd	A18 BER Rear Pan Bd	A19 RPP	A22 YO Driver	A23 Sampler Bd	A24 Frac-N/Divider Bd	AT1 Elec Atten/RPP	AT1 Mech Atten	
ABUS ADC Cal					•							•												
Internal Source Cal					•						•	•												
VCO Bias Adjustment					•							•										•		
Kv vs Frequency Cal					•							•										•		
AM Audio Path Offset					•					•	•	•												
Timebase DAC Cal					•						•	•												
FM Scale DAC Offset Cal					•						•	•												
FM Path Offset Cal					•						•	•												
FM In-band DAC Offset Cal					•						•	•												
FM Invert Amp Offset Cal					•						•	•												
FM1/2 Path Ratio Gain Cal					•						•	•												
Mod Source Relative Gain Cal					•						•	•												
DCFM Cal					•						•	•	•											
Peak Detector Cal					•						•	•												
Burst Modulator Cal					•					•	•													
LF Output Cal					•						•	•												
Burst Audio Path Cal					•					•	•	•												
Prelevel Cal					•						•	•												
VBLO (Mixer Bias Cal)					•						•	•												
I/Q Gain/Offset Quadrature					•		•				•	•												
Gain Adjust					•						•	•						•					•	•
ALC Adjustments					•						•	•						•					•	•
Level Meter Cal					•						•	•												
ALC Mod Flatness Cal					•						•	•												
ALC Mod Driver Bias Cal					•						•	•												
AM Audio Path Gain Cal					•						•	•												
Power Level Accuracy	•1	•1	•1	•1	•						•	•		•			•2	•	•				•	•
Pretune Calibration																								
FM/PM YO Frequency Calibration																								
FM/PM OB Cal																								
LNF Gain Adjust										•														

1. Perform this test only if you *do not* have Option 1EM.
2. Perform this test only if you have Option 1EM.

7 Safety and Regulatory

This chapter provides information on the following:

- general safety information
- lithium battery disposal
- warranty and legal information

Safety Notes

The following safety notes are used throughout this manual. Familiarize yourself with each of the notes and its meaning before operating this instrument.

CAUTION Caution denotes a hazard. It calls attention to a procedure that, if not correctly performed or adhered to, would result in damage to or destruction of the product. Do not proceed beyond a caution sign until the indicated conditions are fully understood and met.

WARNING Warning denotes a hazard. It calls attention to a procedure which, if not correctly performed or adhered to, could result in injury or loss of life. Do not proceed beyond a warning note until the indicated conditions are fully understood and met.

General Safety Considerations

The following safety notes apply specifically to ESG Family Signal Generators. These notes also appear in other chapters of this service guide as required.

-
- | | |
|----------------|--|
| WARNING | These servicing instructions are for use by qualified personal only. To avoid electrical shock, do not perform any servicing unless you are qualified to do so. |
|----------------|--|
-
- | | |
|----------------|--|
| WARNING | The opening of covers or removal of parts is likely to expose dangerous voltages. Disconnect the product from all voltage sources while it is being opened. |
|----------------|--|
-
- | | |
|----------------|---|
| WARNING | The detachable power cord is the instrument disconnecting device. It disconnects the mains circuits from the mains supply before other parts of the instrument. The front panel switch is only a standby switch and is not a LINE switch (disconnecting device). |
|----------------|---|
-
- | | |
|----------------|--|
| WARNING | The power cord is connected to internal capacitors that may remain live for 5 seconds after disconnecting the plug from its power supply. |
|----------------|--|
-
- | | |
|----------------|--|
| WARNING | This is a Safety Class 1 Product (provided with a protective earthing ground incorporated in the power cord). The mains plug shall only be inserted in a socket outlet provided with a protective earth contact. Any interruption of the protective conductor inside or outside of the product is likely to make the product dangerous. Intentional interruption is prohibited. |
|----------------|--|
-
- | | |
|----------------|--|
| WARNING | Danger of explosion if battery if incorrectly replaced. Replace only with the same or equivalent type recommended. Discard used batteries according to manufacturer's instructions. |
|----------------|--|
-
- | | |
|----------------|--|
| CAUTION | Many of the assemblies in this instrument are very susceptible to damage from ESD (electrostatic discharge). Perform service procedures only at a static-safe workstation and wear a grounding strap. |
|----------------|--|
-

Lithium Battery Disposal

When the battery on the A14 CPU/Motherboard is exhausted and/or ready for disposal, dispose of it according to your country's requirements. You can return the battery to your nearest Agilent Technologies Sales and Service office for disposal, if required. (Refer to Chapter 1, "Initial Troubleshooting and RF Block Diagrams," for a list of Agilent Technologies Sales and Service offices.)

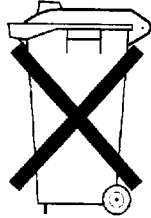

**DO NOT THROW BATTERIES AWAY BUT
COLLECT AS SMALL CHEMICAL WASTE.**

sk780a

Warranty

This Agilent Technologies instrument product is warranted against defects in material and workmanship for a period of three years from date of shipment. During the warranty period, Agilent Technologies will, at its option, either repair or replace products which prove to be defective.

For warranty service or repair, this product must be returned to a service facility designated by Agilent Technologies. Buyer shall prepay shipping charges to Agilent Technologies and Agilent Technologies shall pay shipping charges to return the product to Buyer. However, Buyer shall pay all shipping charges, duties, and taxes for products returned to Agilent Technologies from another country.

Agilent Technologies warrants that its software and firmware designated by Agilent Technologies for use with an instrument will execute its programming instructions when properly installed on that instrument. Agilent Technologies does not warrant that the operation of the instrument, or software, or firmware will be uninterrupted or error-free.

Limitation of Warranty

The foregoing warranty shall not apply to defects resulting from improper or inadequate maintenance by Buyer, Buyer-supplied software or interfacing, unauthorized modification or misuse, operation outside of the environmental specifications for the product, or improper site preparation or maintenance.

NO OTHER WARRANTY IS EXPRESSED OR IMPLIED. AGILENT TECHNOLOGIES SPECIFICALLY DISCLAIMS THE IMPLIED WARRANTIES OF MERCHANTABILITY AND FITNESS FOR A PARTICULAR PURPOSE.

Exclusive Remedies

THE REMEDIES PROVIDED HEREIN ARE BUYER'S SOLE AND EXCLUSIVE REMEDIES. AGILENT TECHNOLOGIES SHALL NOT BE LIABLE FOR ANY DIRECT, INDIRECT, SPECIAL, INCIDENTAL, OR CONSEQUENTIAL DAMAGES, WHETHER BASED ON CONTRACT, TORT, OR ANY OTHER LEGAL THEORY.

Assistance

Product maintenance agreements and other customer assistance agreements are available for Agilent Technologies products. For any assistance, contact your nearest Agilent Technologies sales and service office. (Refer to Chapter 1, “Initial Troubleshooting and RF Block Diagrams.”)

Notice

The information contained in this document is subject to change without notice.

Agilent Technologies makes no warranty of any kind with regard to this material, including but not limited to, the implied warranties of merchantability and fitness for a particular purpose. Agilent Technologies shall not be liable for errors contained herein or for incidental or consequential damages in connection with the furnishing, performance, or use of this material.

Certification

Agilent Technologies Company certifies that this product met its published specifications at the time of shipment from the factory. Agilent Technologies further certifies that its calibration measurements are traceable to the United States National Institute of Standards and Technology, to the extent allowed by the Institute's calibration facility, and to the calibration facilities of other International Standards Organization members.

ESG-D SERIES RF BLOCK DIAGRAM

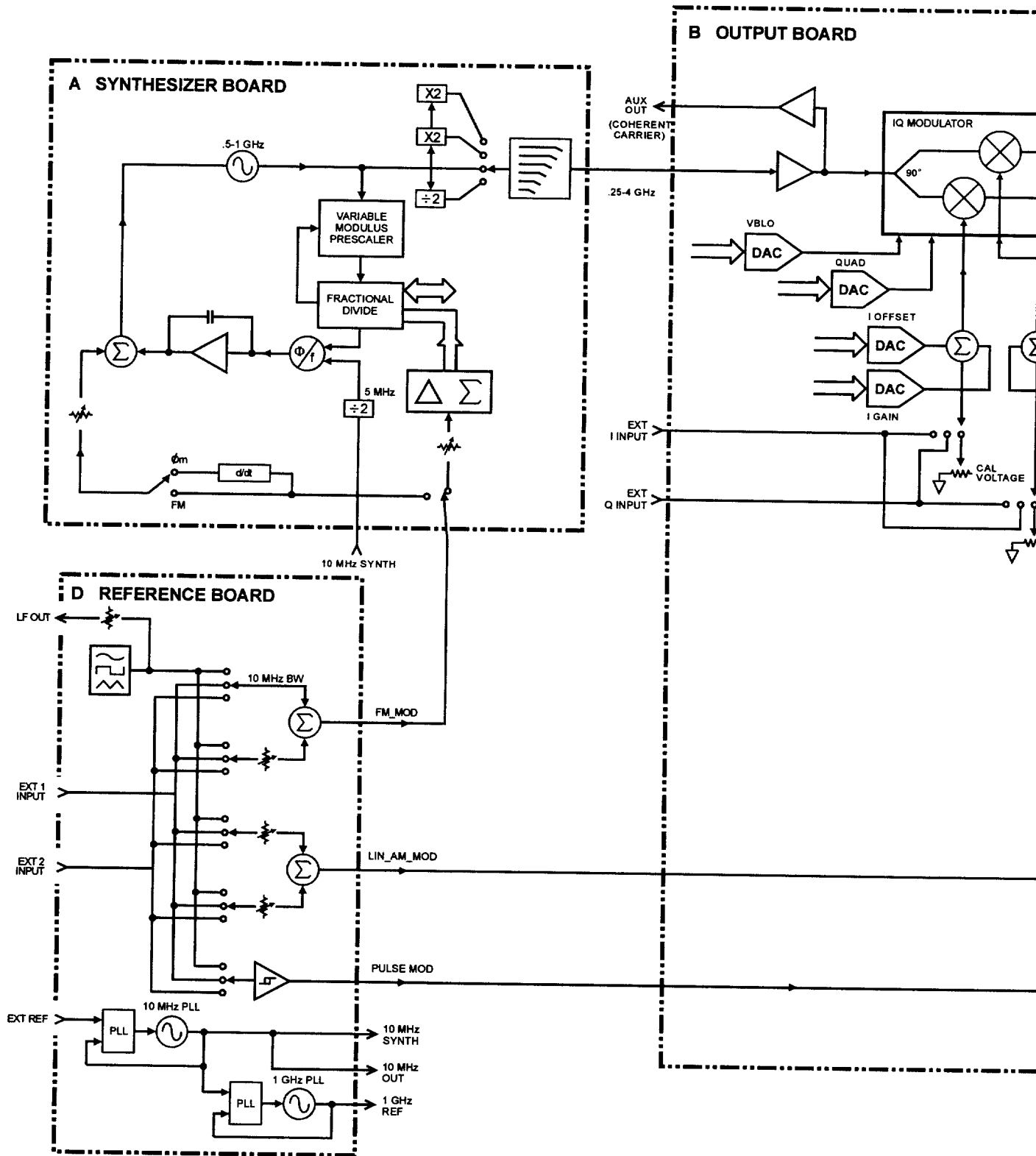

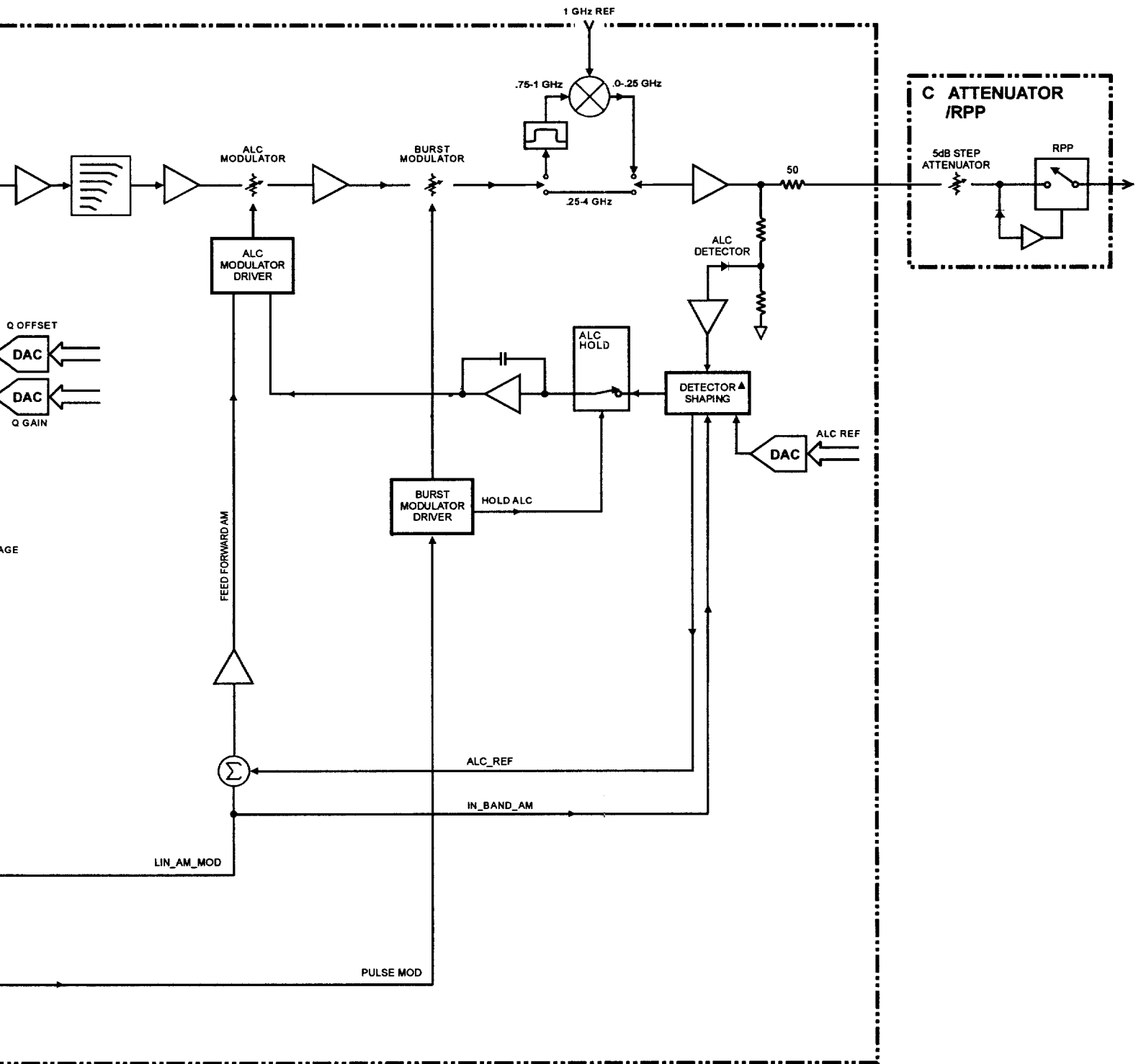

ESG-D SERIES RF BLOCK DIAGRAM

ESG-D SERIES RF BLOCK DIAGRAM (OPTIONS UN3 & UN4)

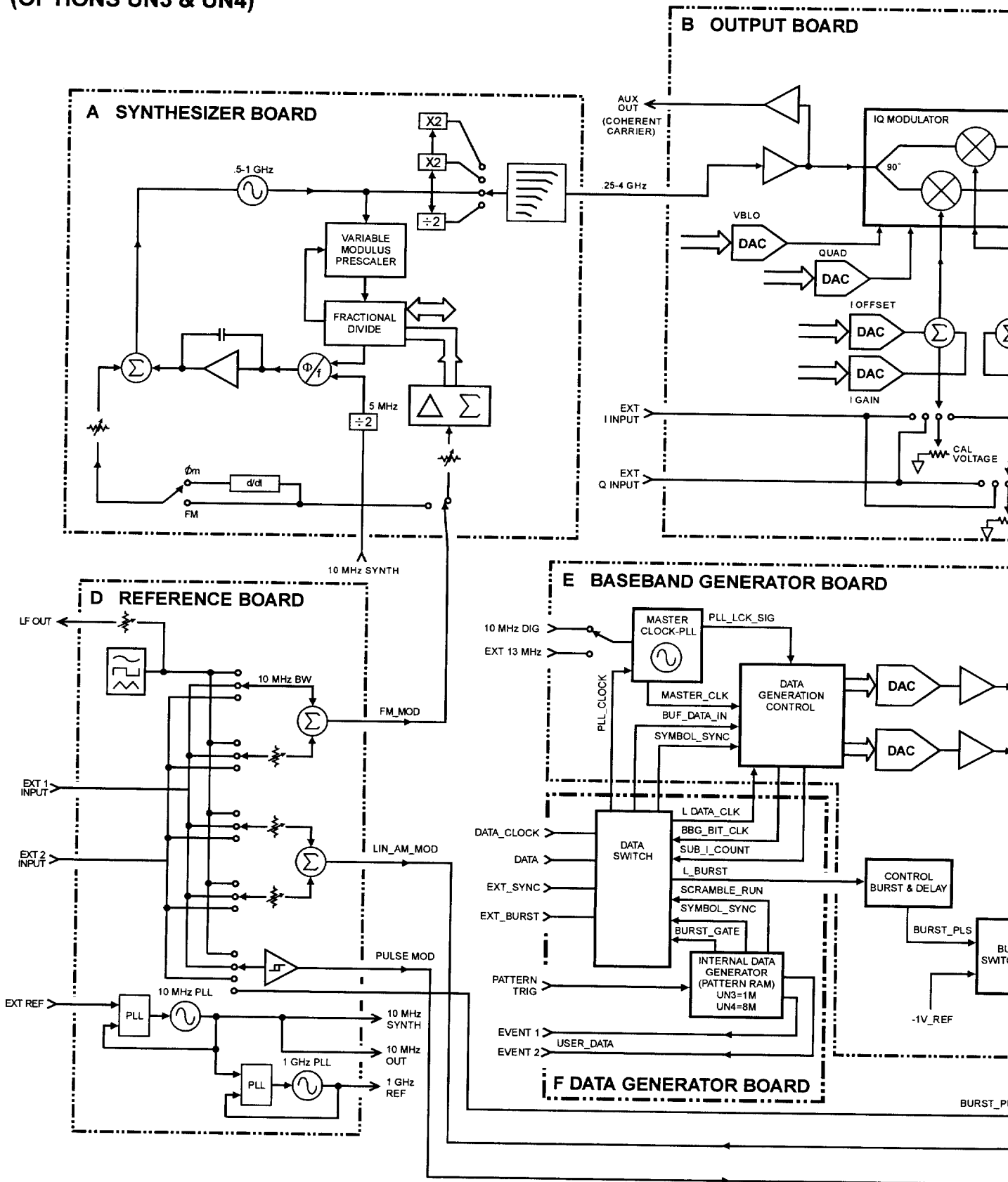

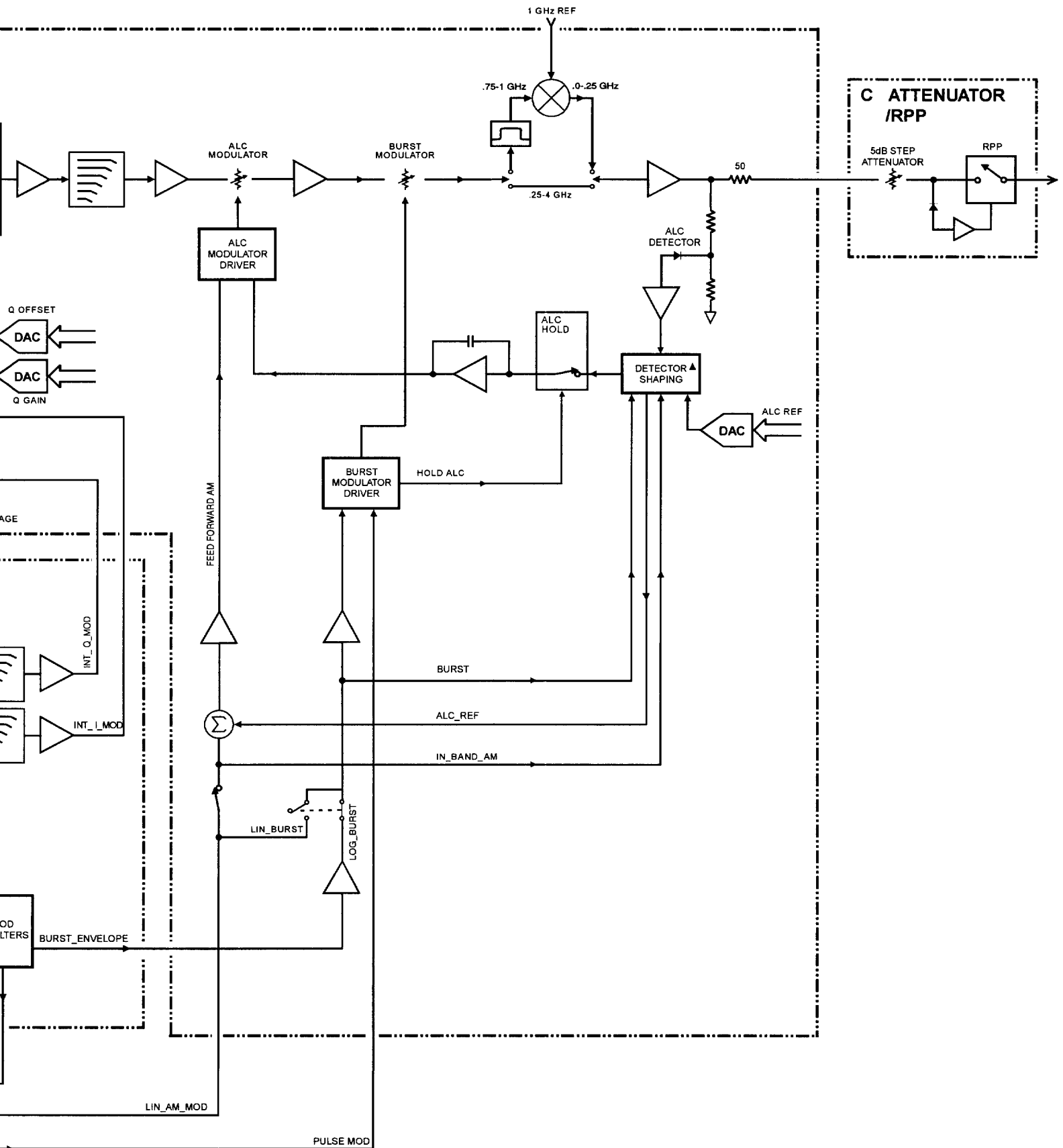

ESG-D SERIES RF BLOCK DIAGRAM (OPTIONS UN3 & UN4)

ESG-D SERIES RF BLOCK DIAGRAM (OPTION UN7)

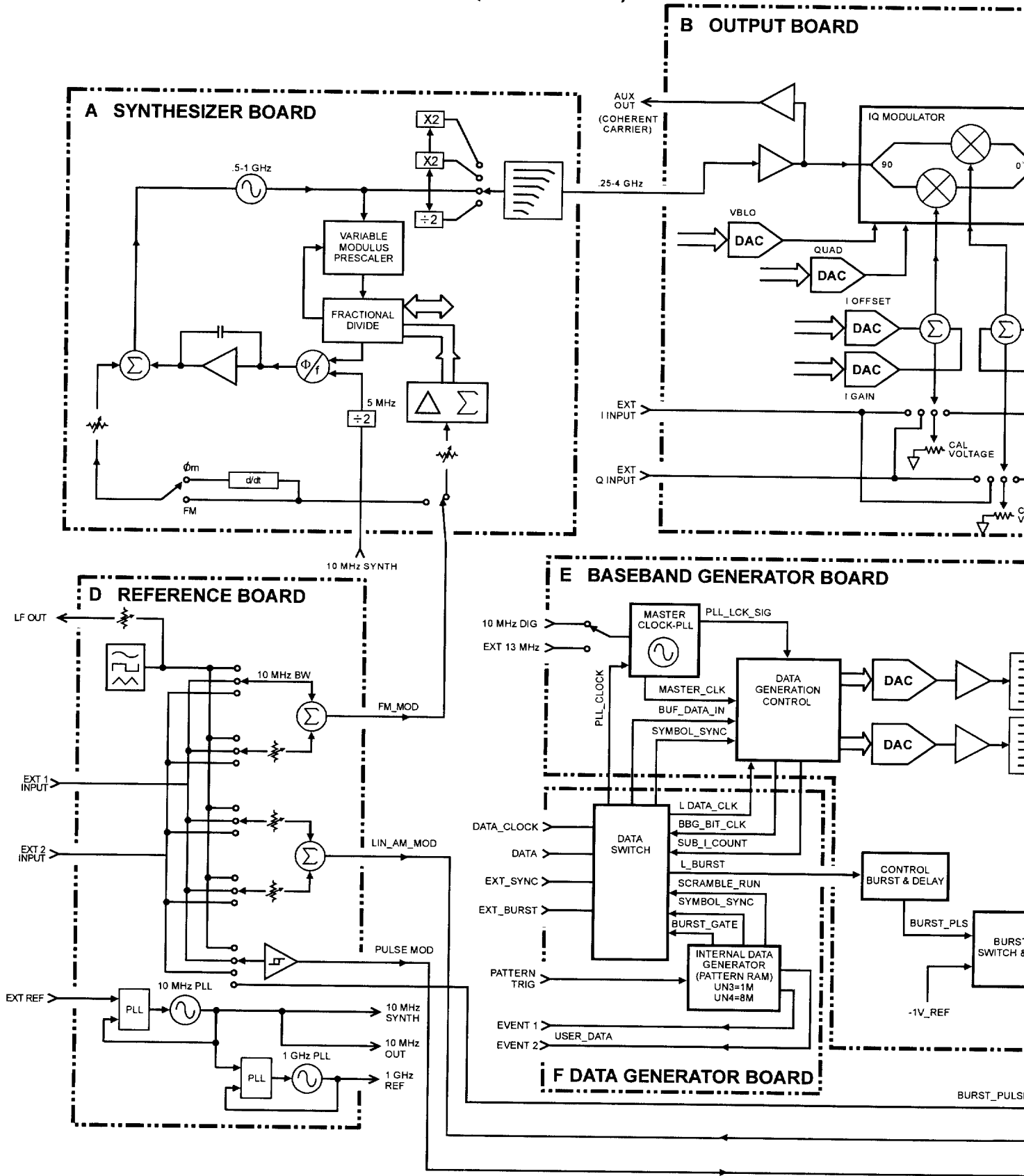

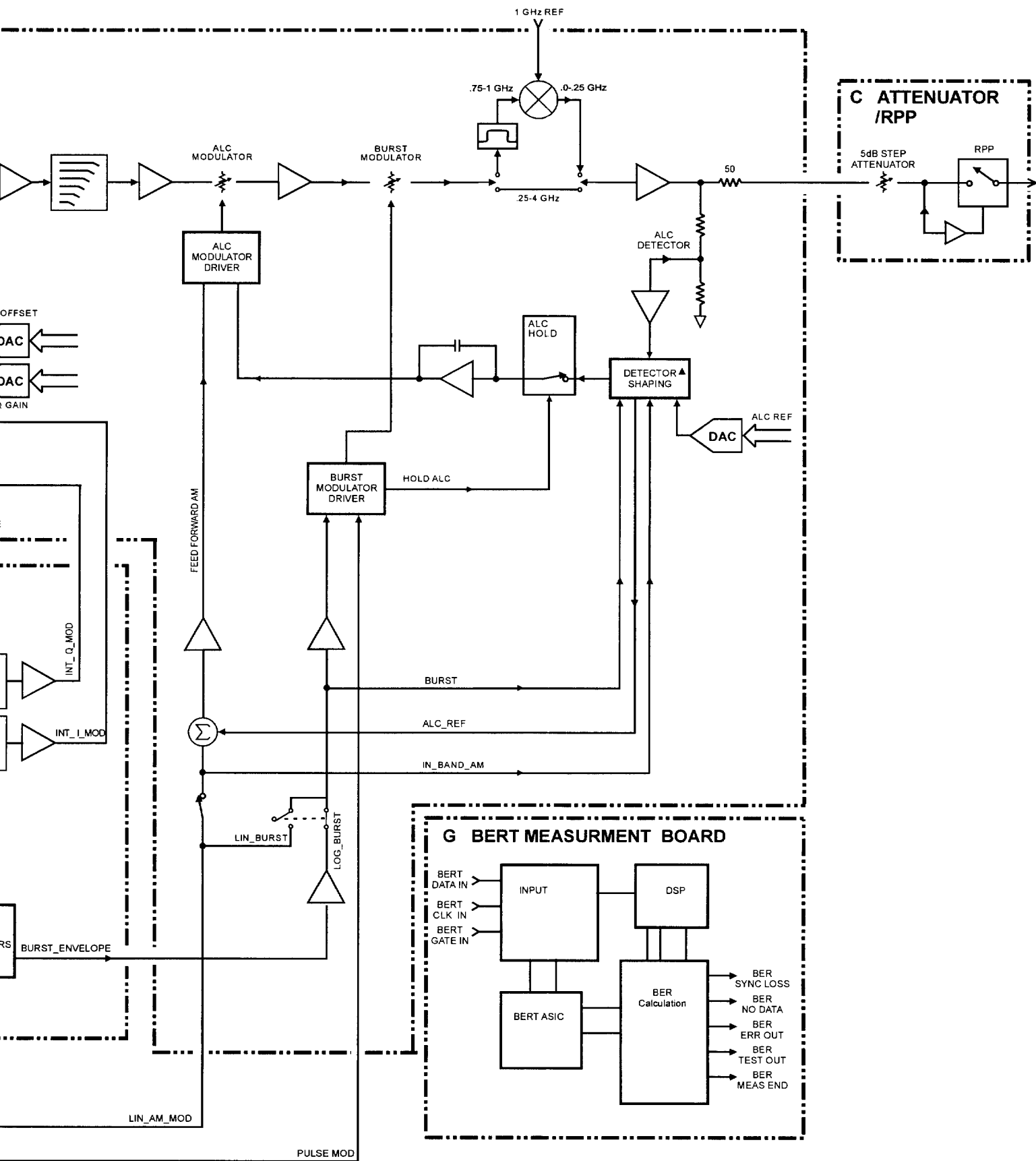

ESG-D SERIES RF BLOCK DIAGRAM (OPTION UN7)

ESG-D SERIES RF BLOCK DIAGRAM (OPTIONS UN8 & UN9)

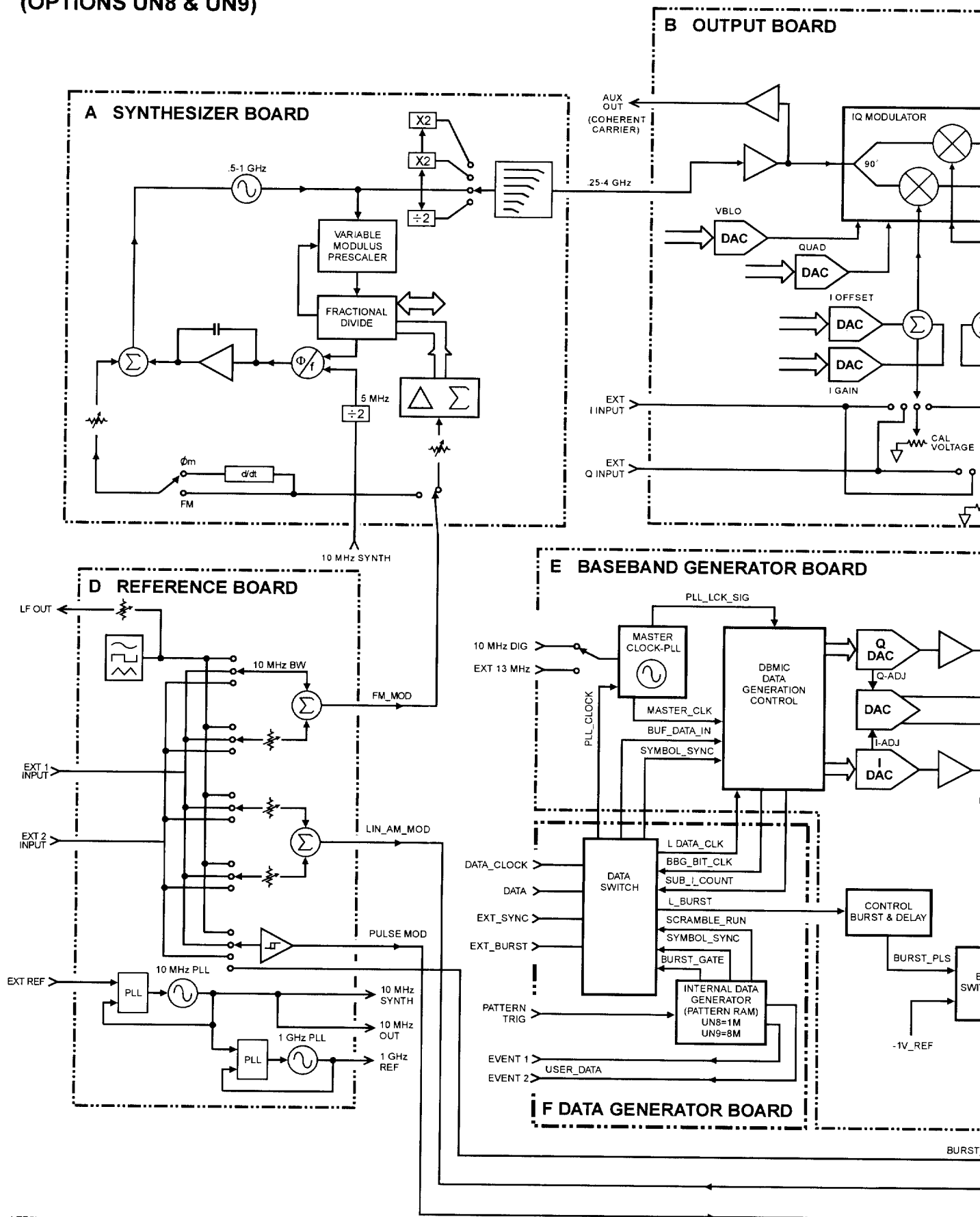

ESG-D SERIES RF BLOCK DIAGRAM (OPTION UND)

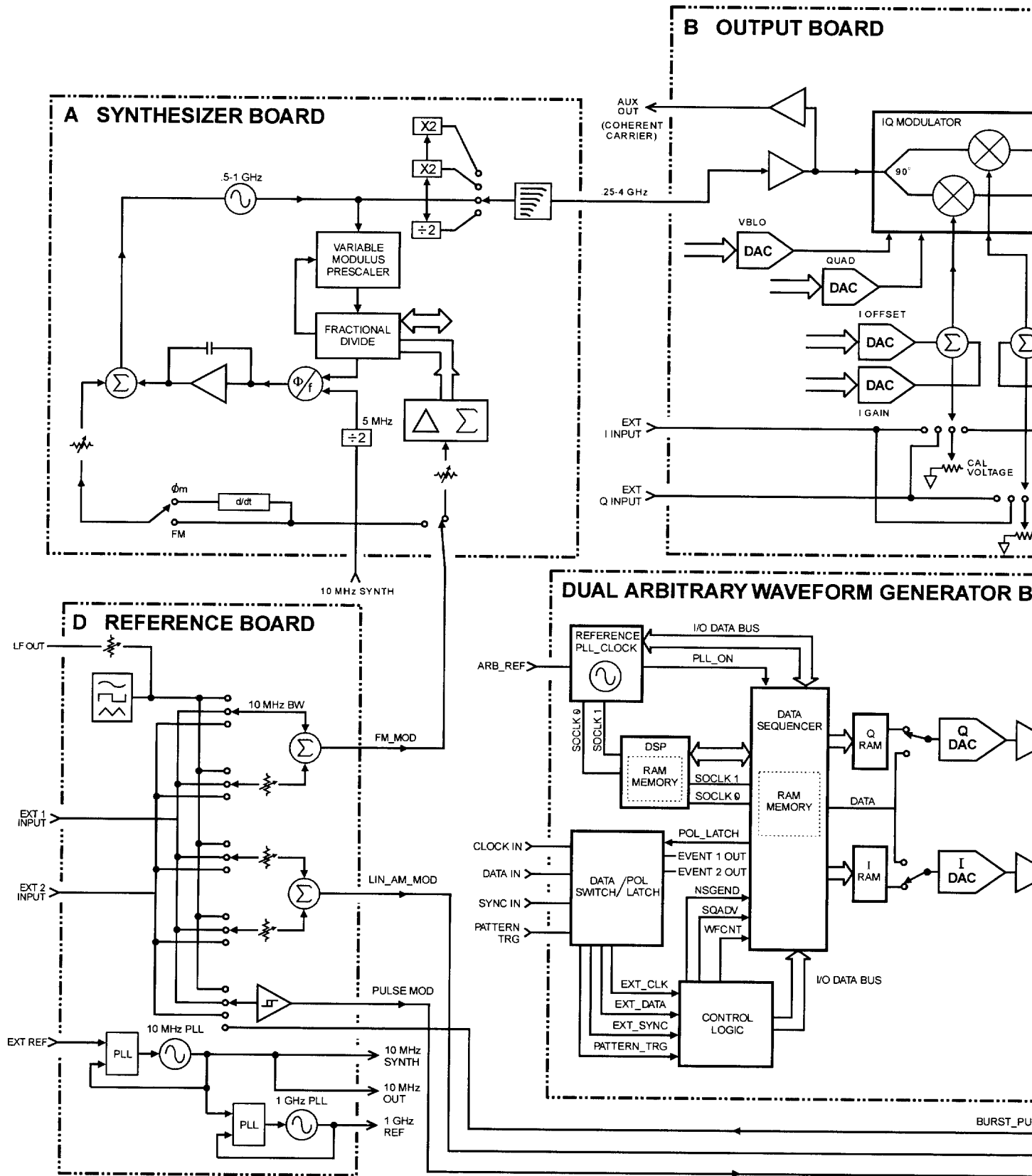

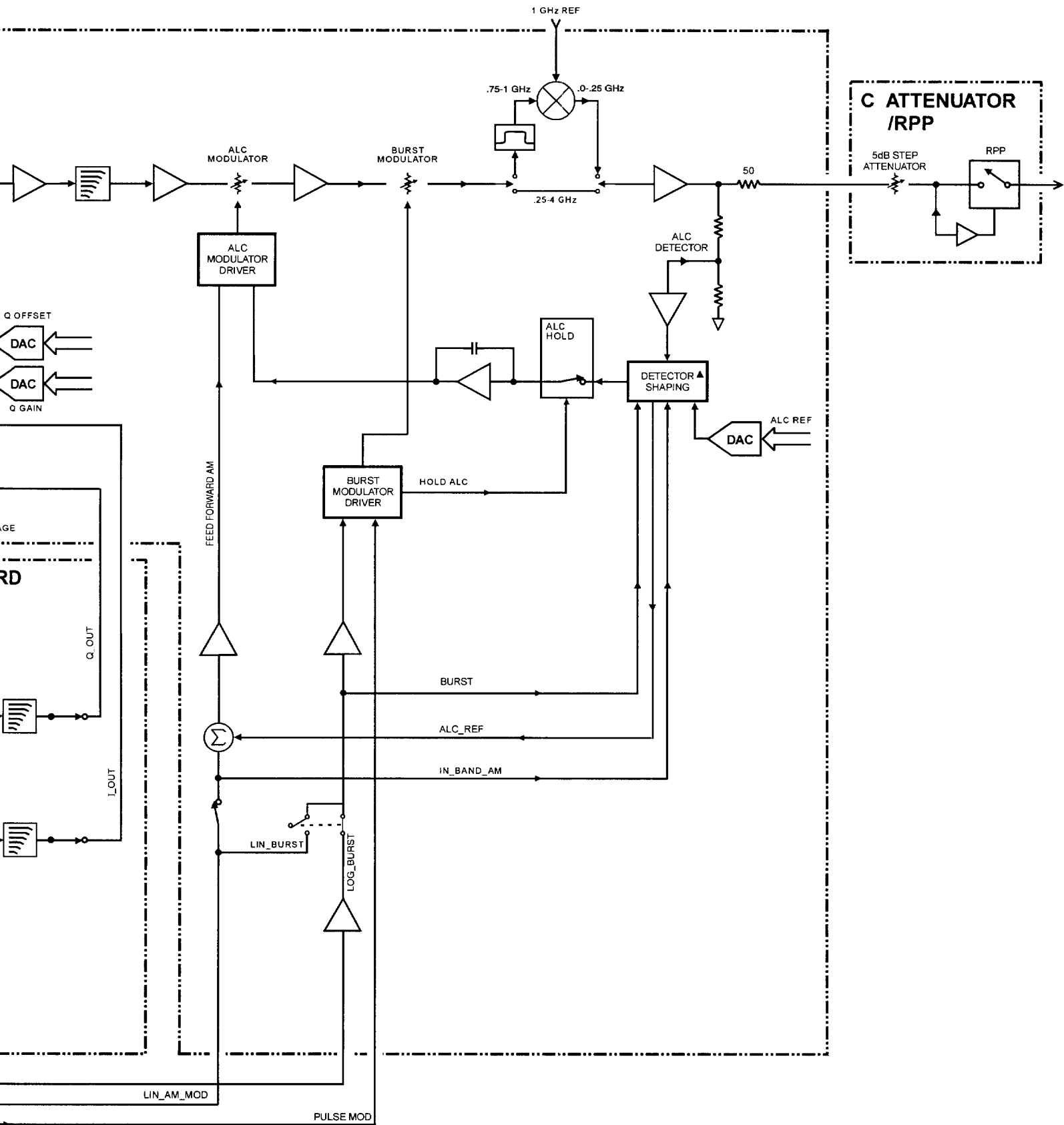

ESG-D SERIES RF BLOCK DIAGRAM (OPTION UND)

ESG-D SERIES RF BLOCK DIAGRAM (OPTION UN7, UN8/UN9, 300)

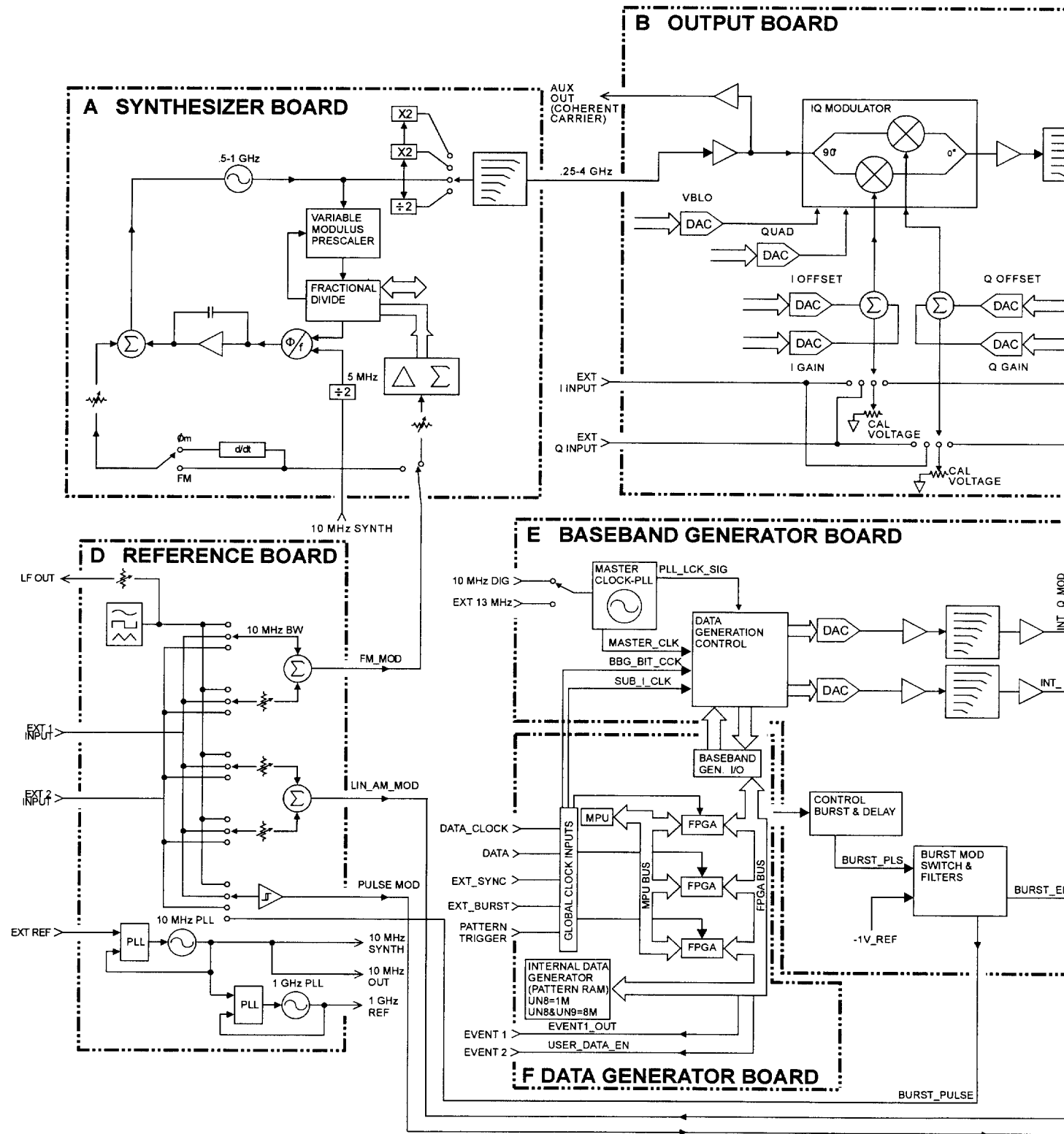

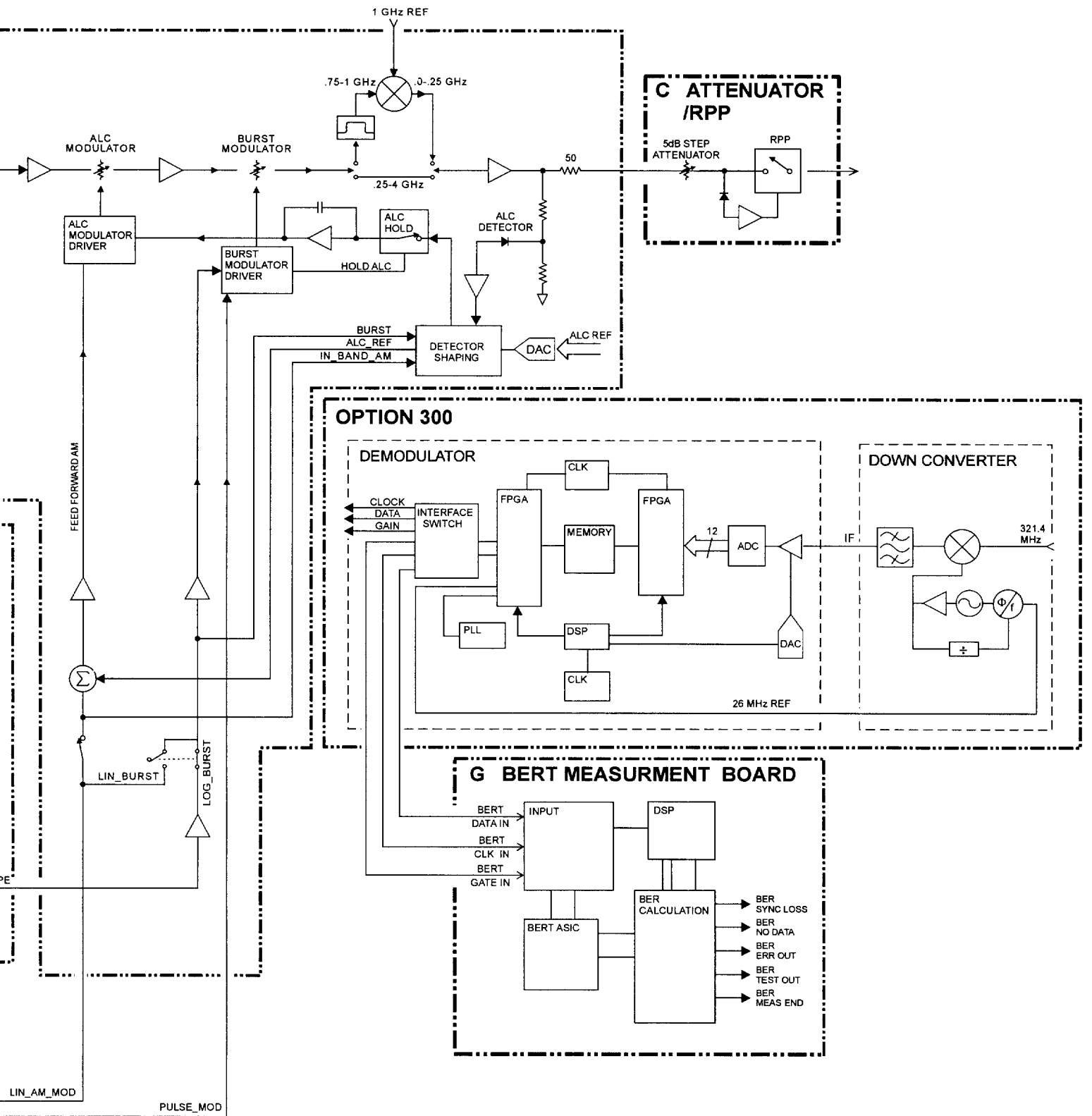

ESG-D SERIES RF BLOCK DIAGRAM (OPTION UN7, UN8/UN9, 300)

A7 DBMIC BASEBAND GENERATOR BLOCK DIAGRAM (OPTIONS UN8 and UN9)

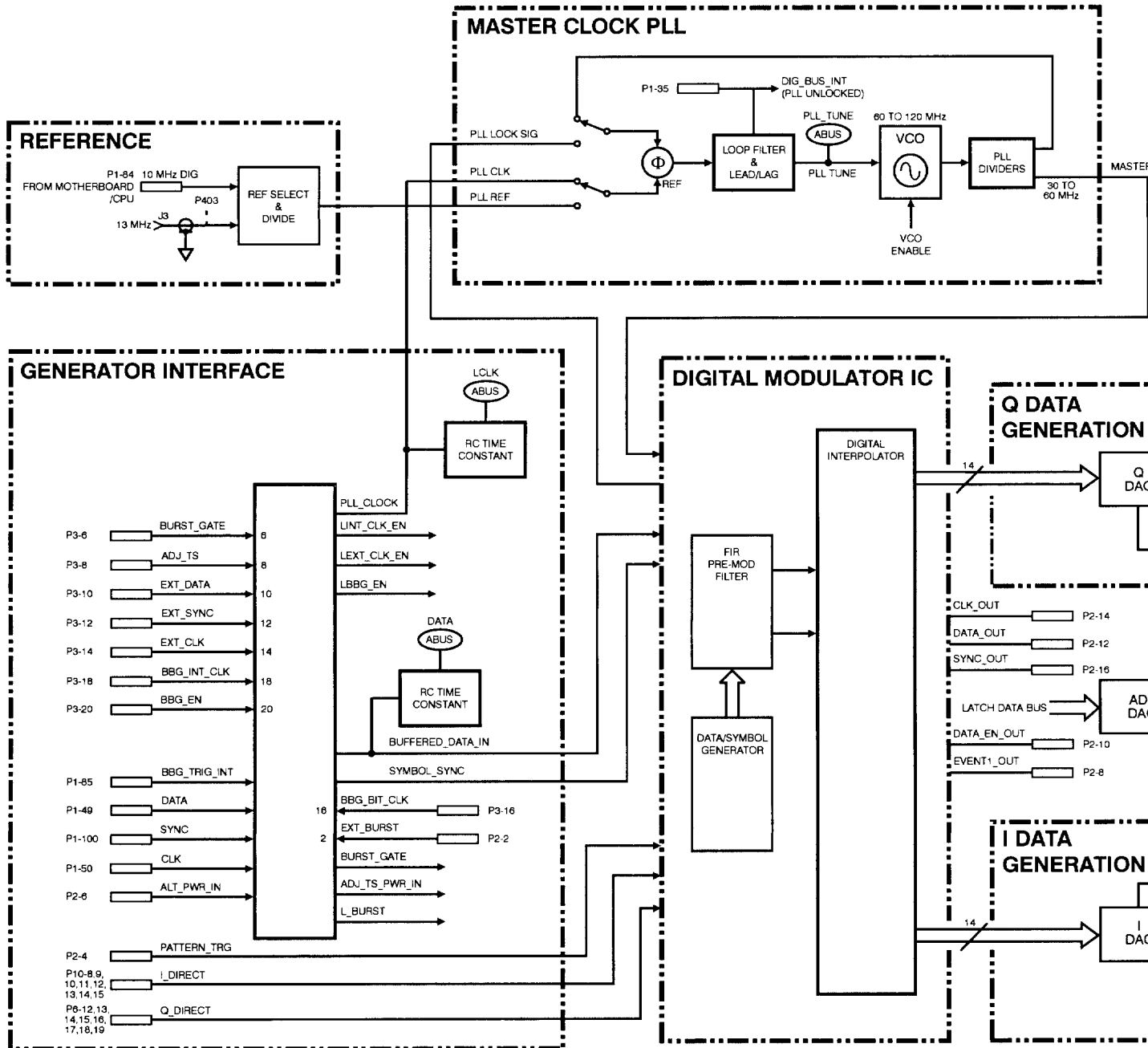

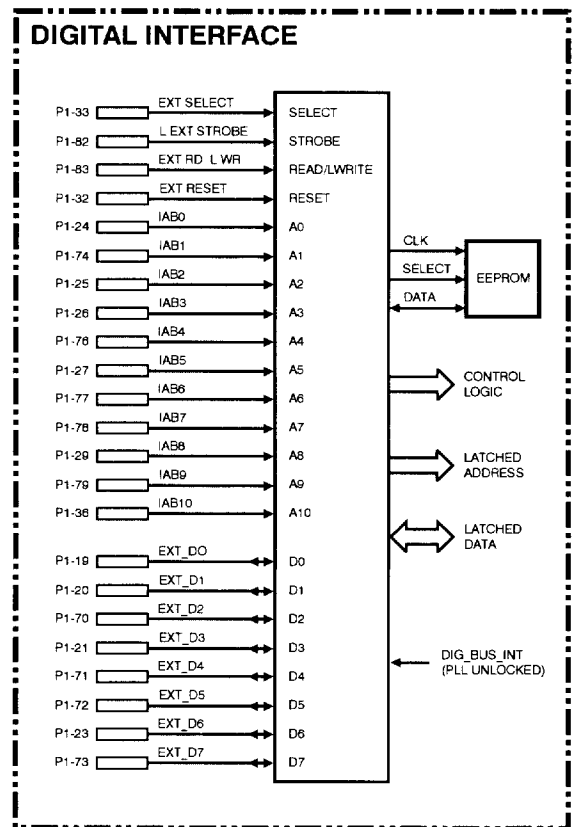
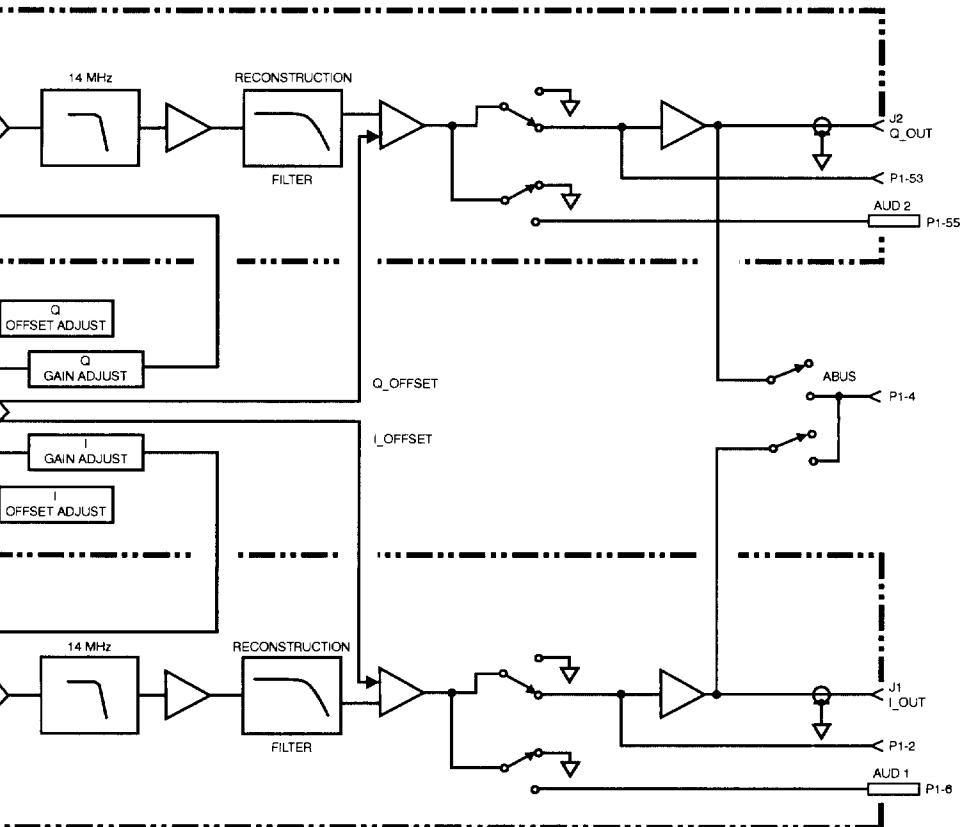
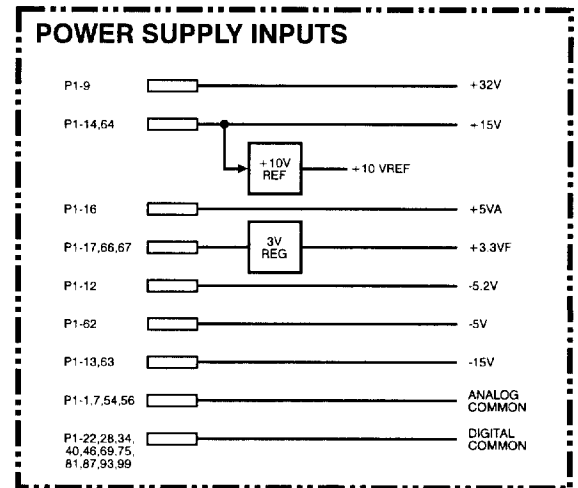
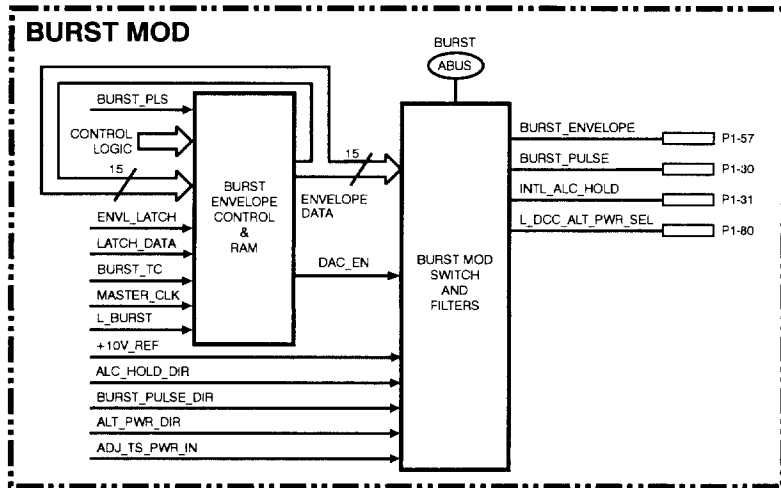

A7 DBMIC BASEBAND GENERATOR BLOCK DIAGRAM (OPTIONS UN8 and UN9)

A8 FLEX GENERATOR BLOCK DIAGRAM REV. C & D (OPTION UN8 & UN9)

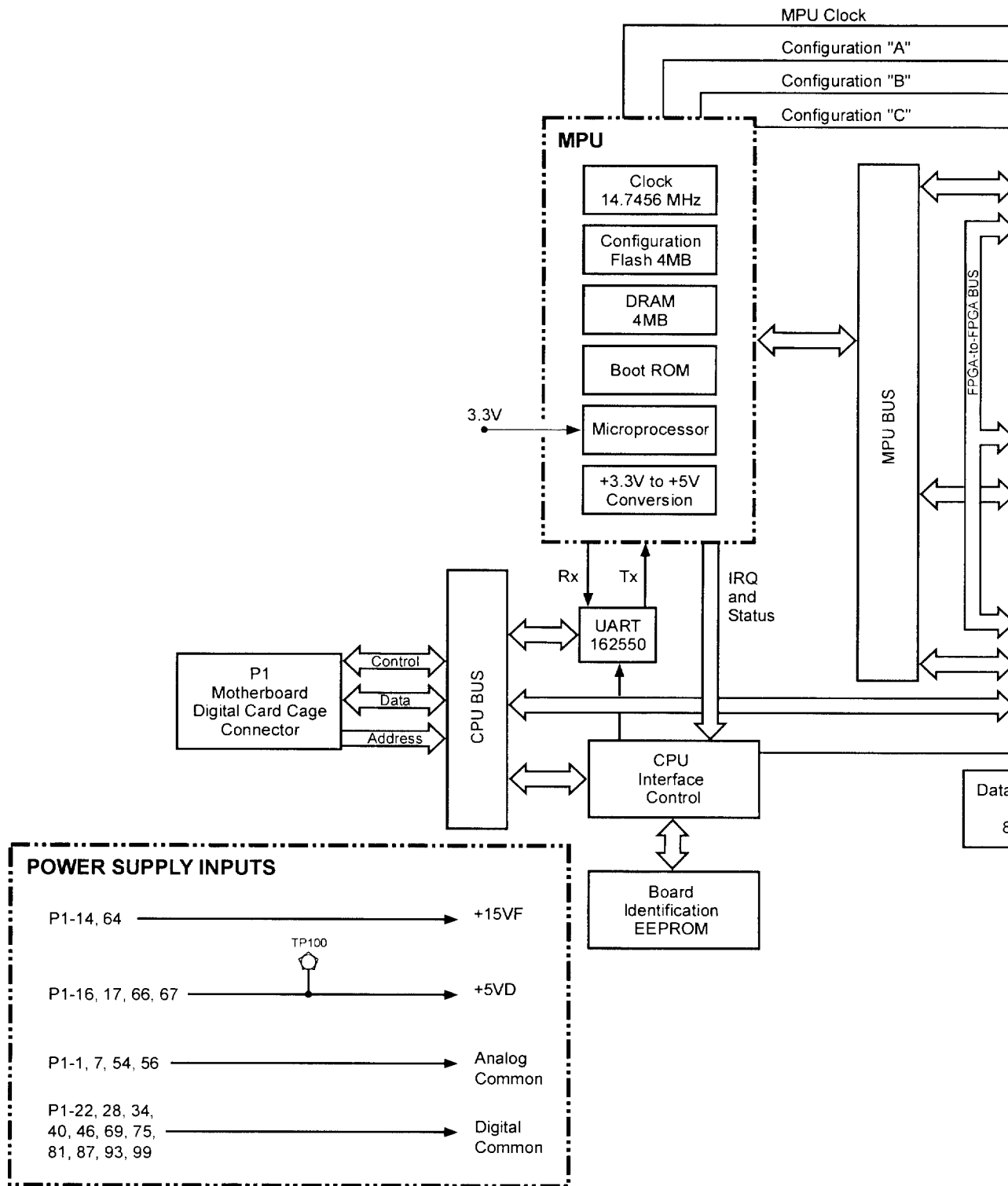

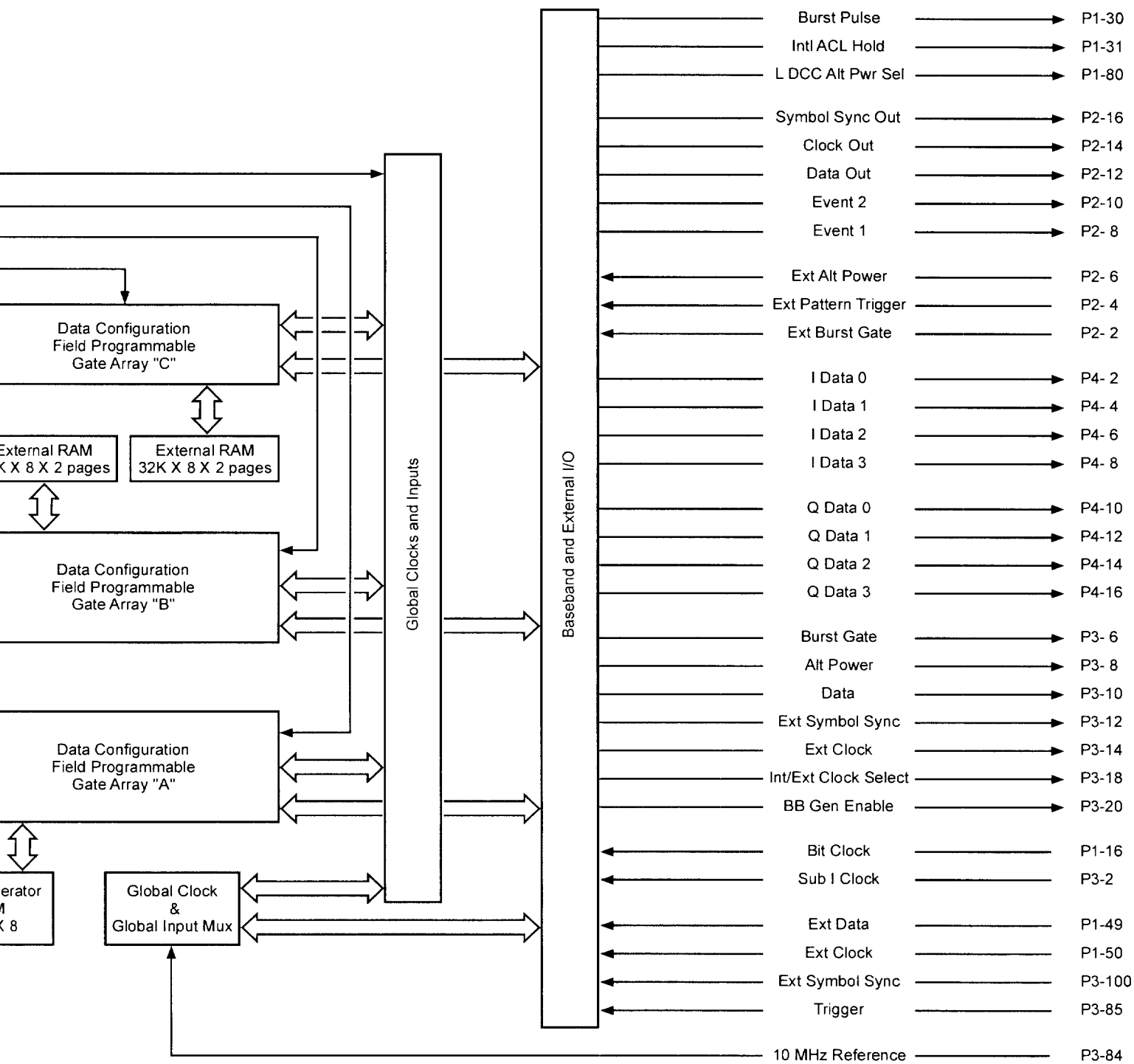

**A8 FLEX GENERATOR BLOCK DIAGRAM
REV. C & D (OPTION UN8 & UN9)**

ESG-D SERIES MODULATION AND SIGNAL INTERCONNECTS (2 of 2)

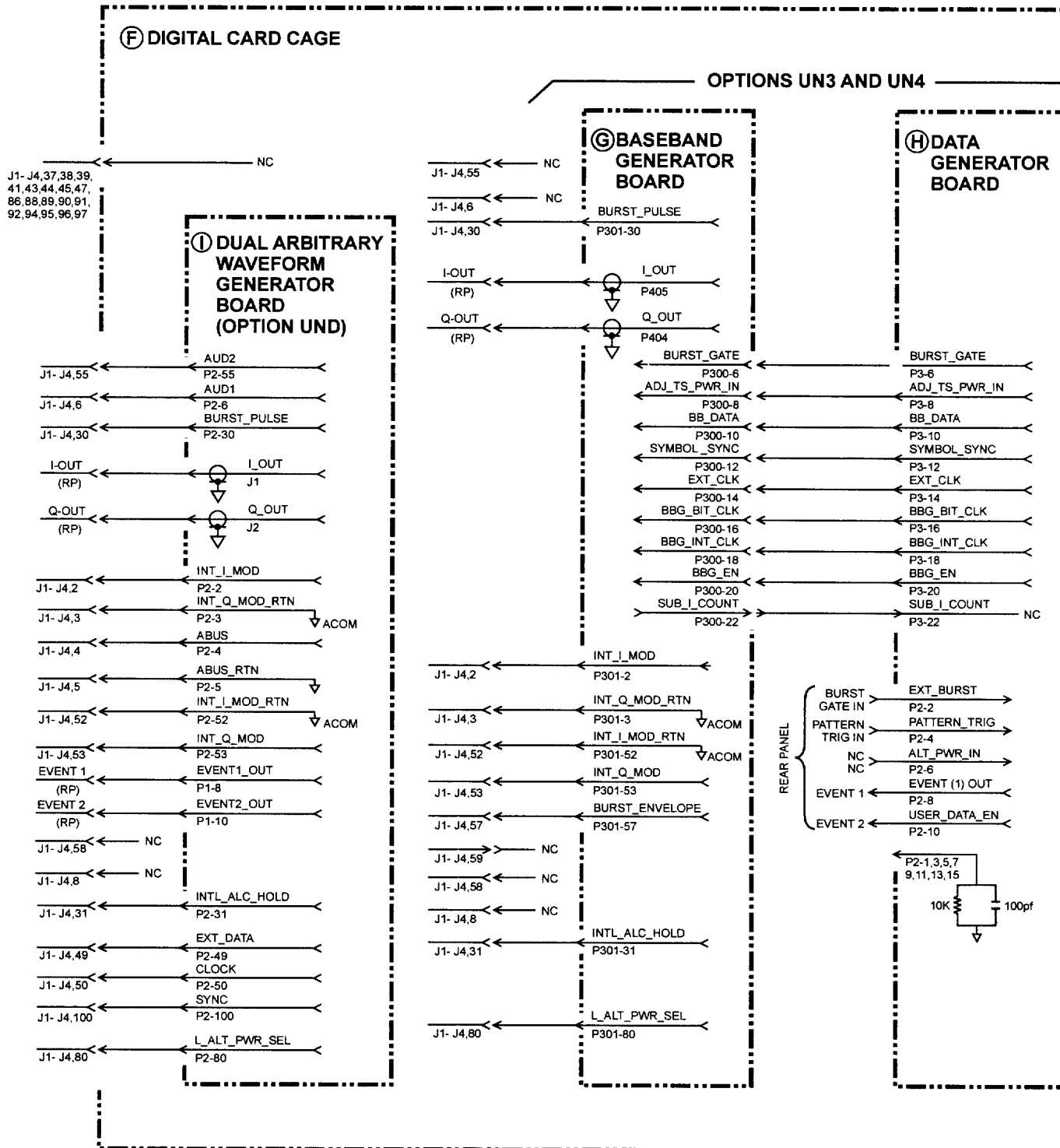

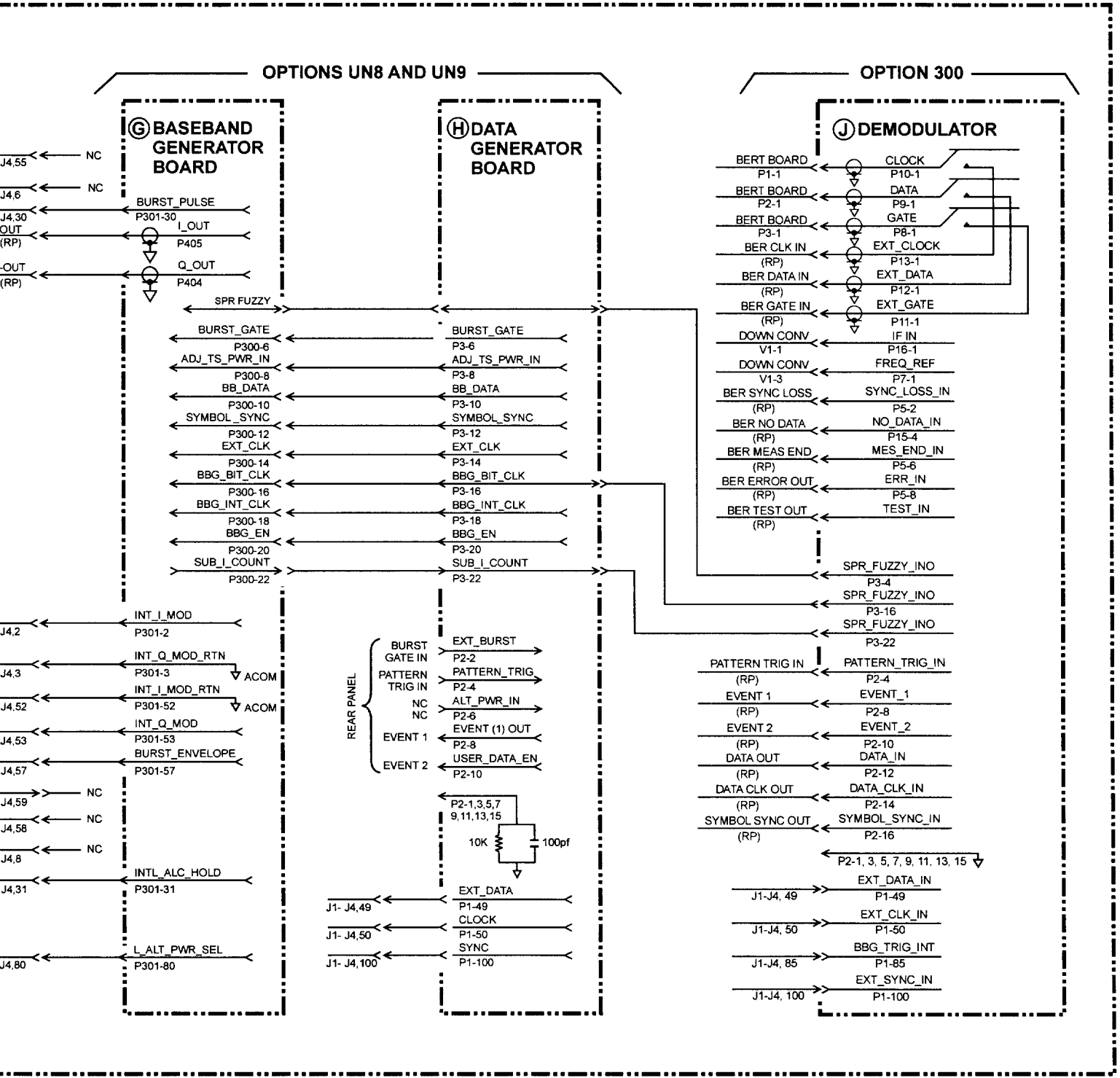

A21 DEMODULATOR BLOCK DIAGRAM (OPTION 300)

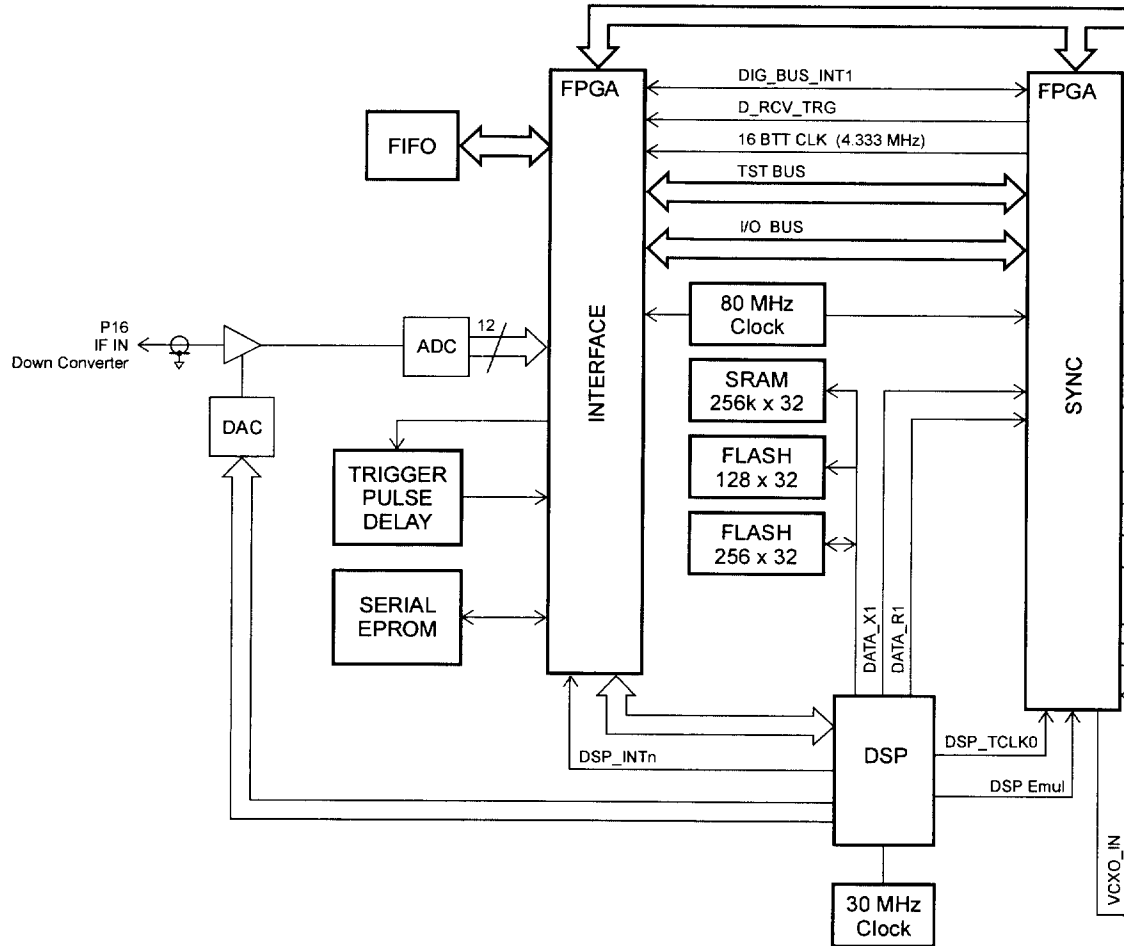

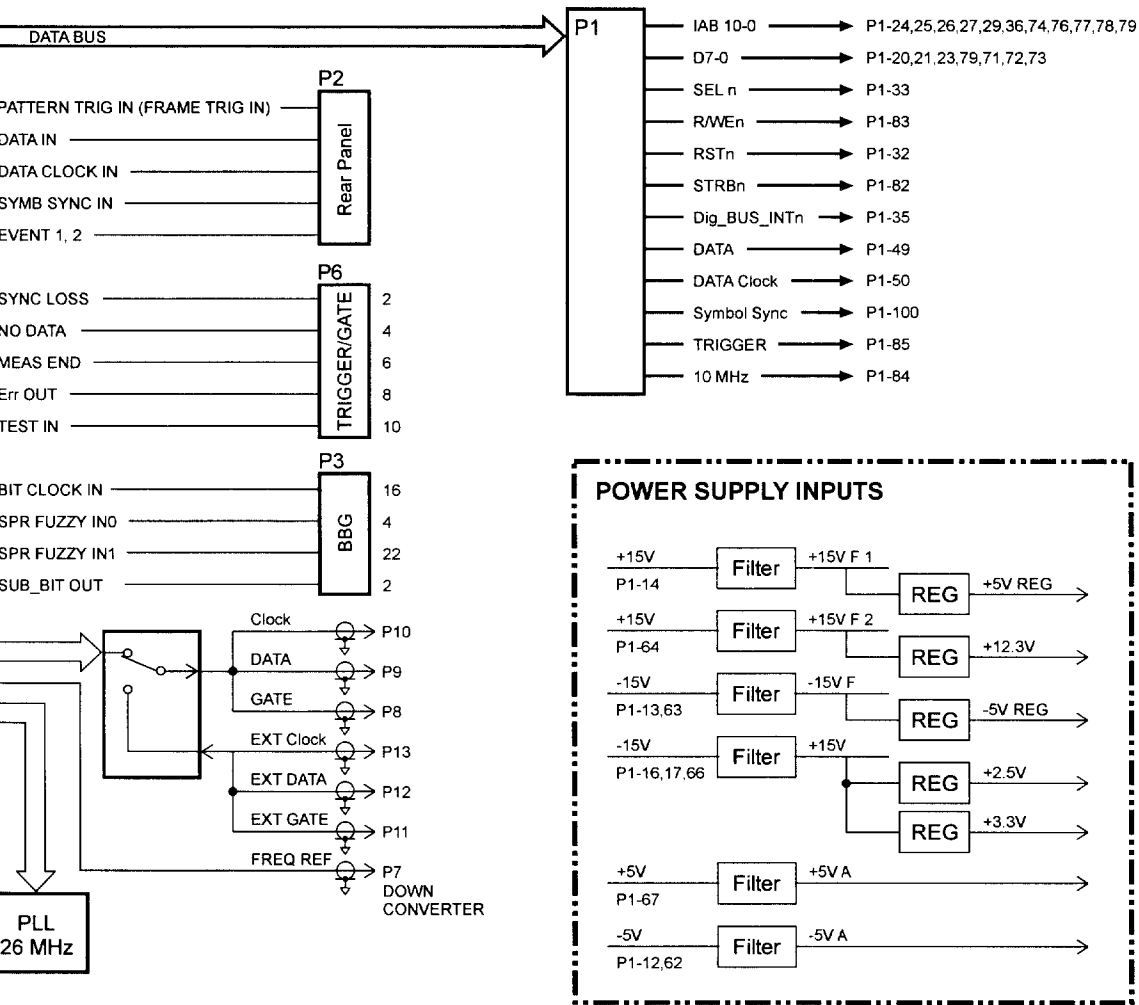

A21 DEMODULATOR BLOCK DIAGRAM (OPTION 300)

A22 YIG DRIVER BLOCK DIAGRAM

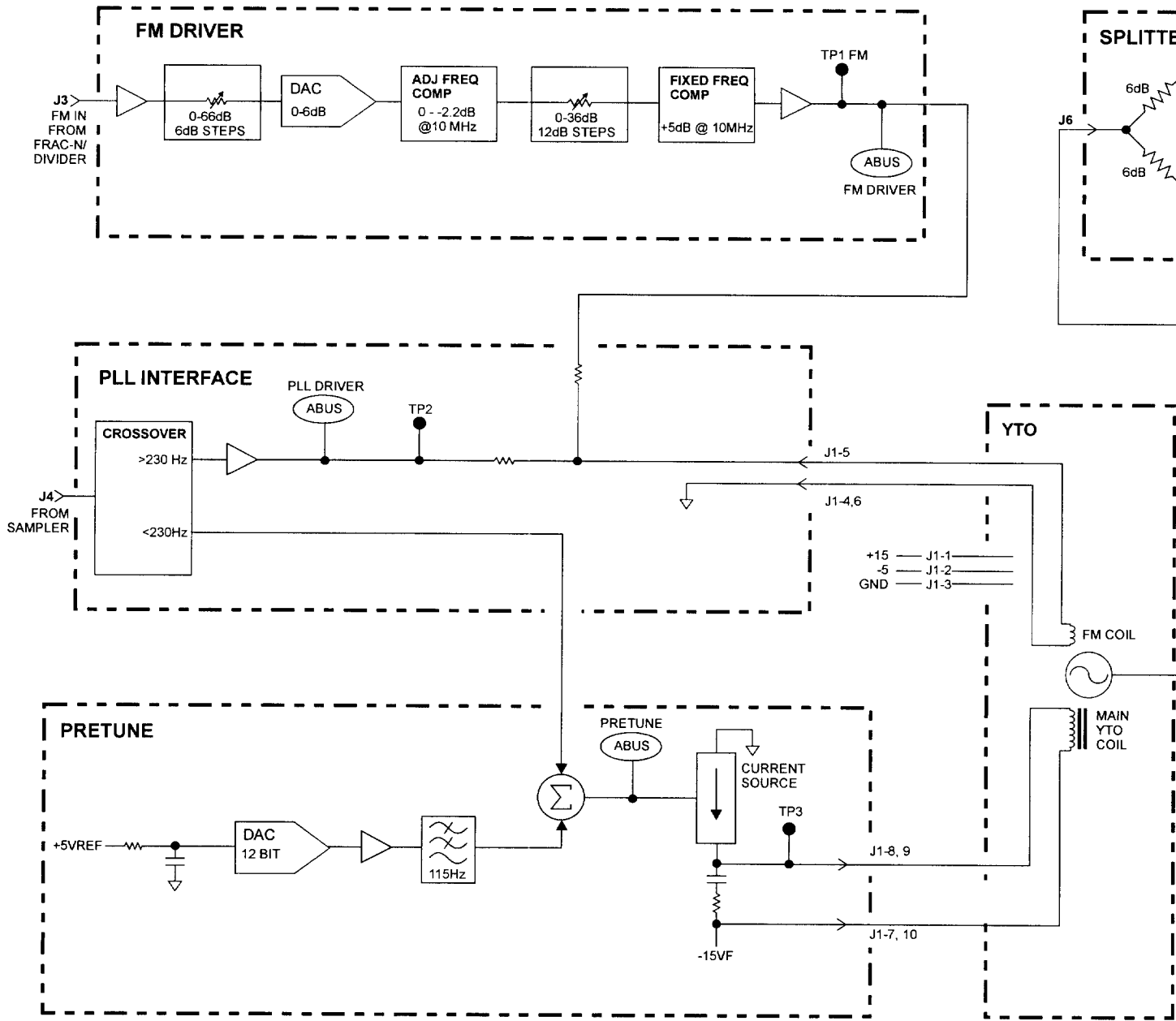

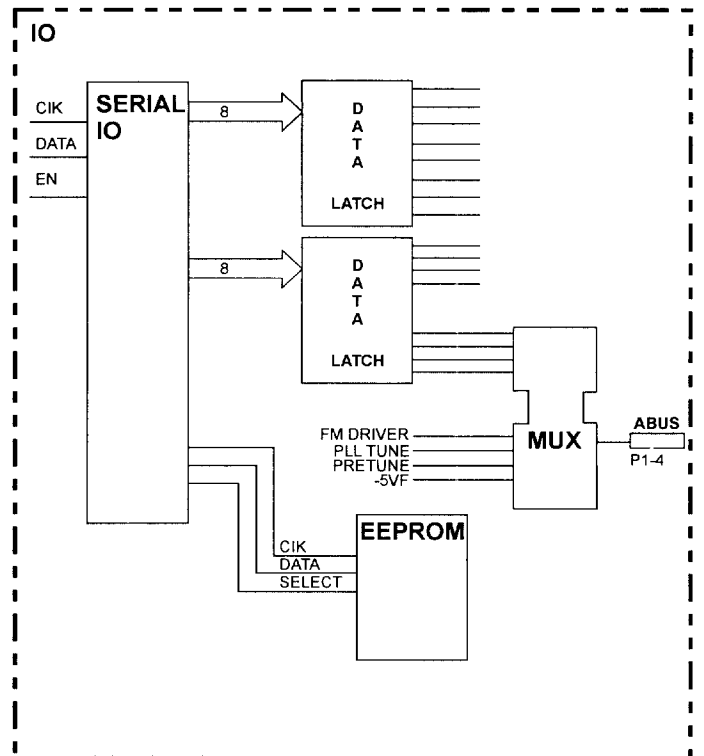
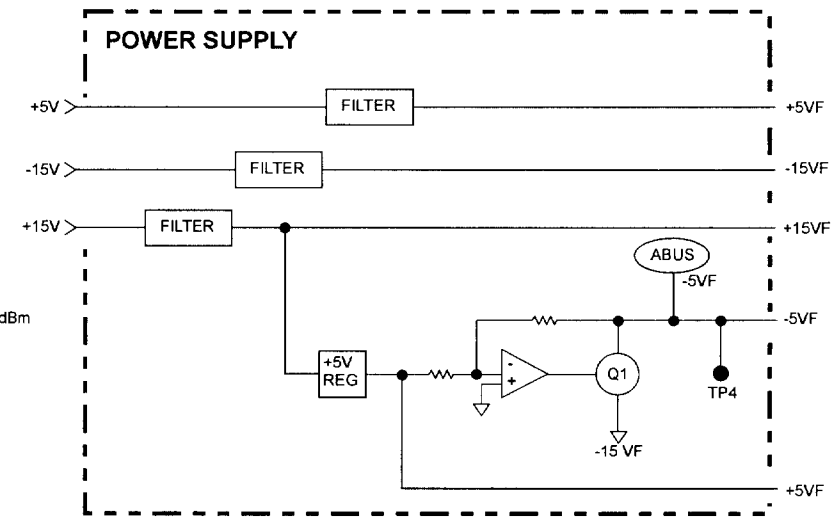
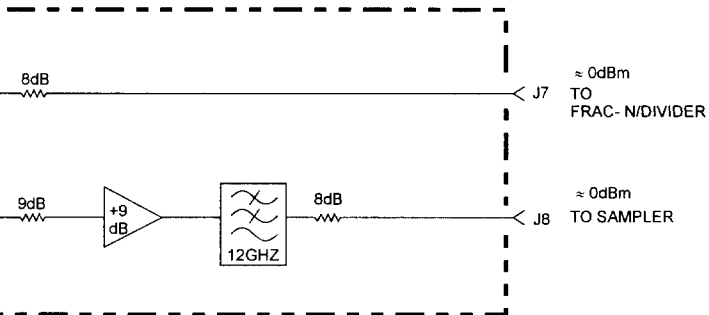

A22 YIG DRIVER BLOCK DIAGRAM

ESG-D SERIES POWER SUPPLY & GROUND INTERCONNECTS (1 OF 2)

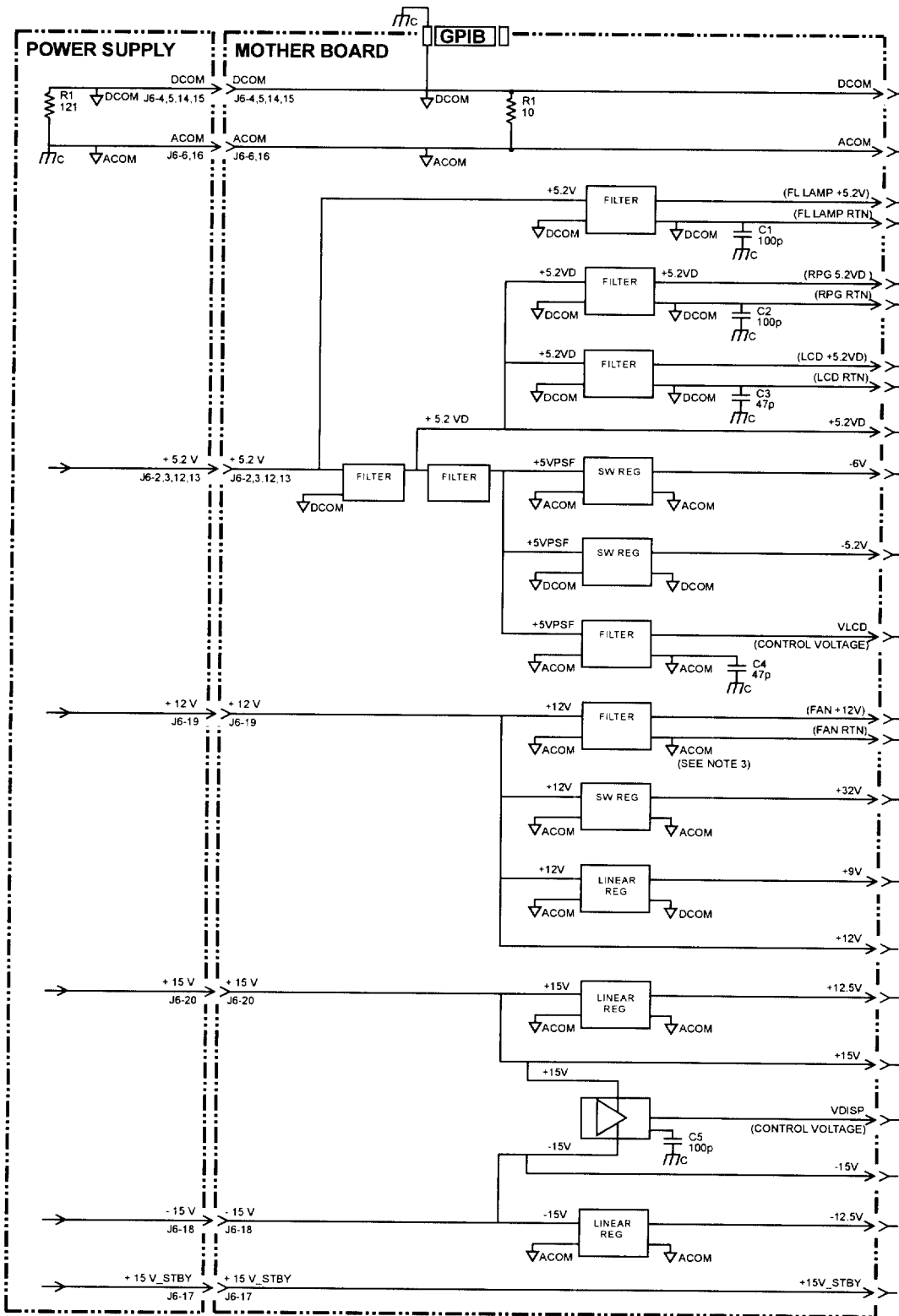

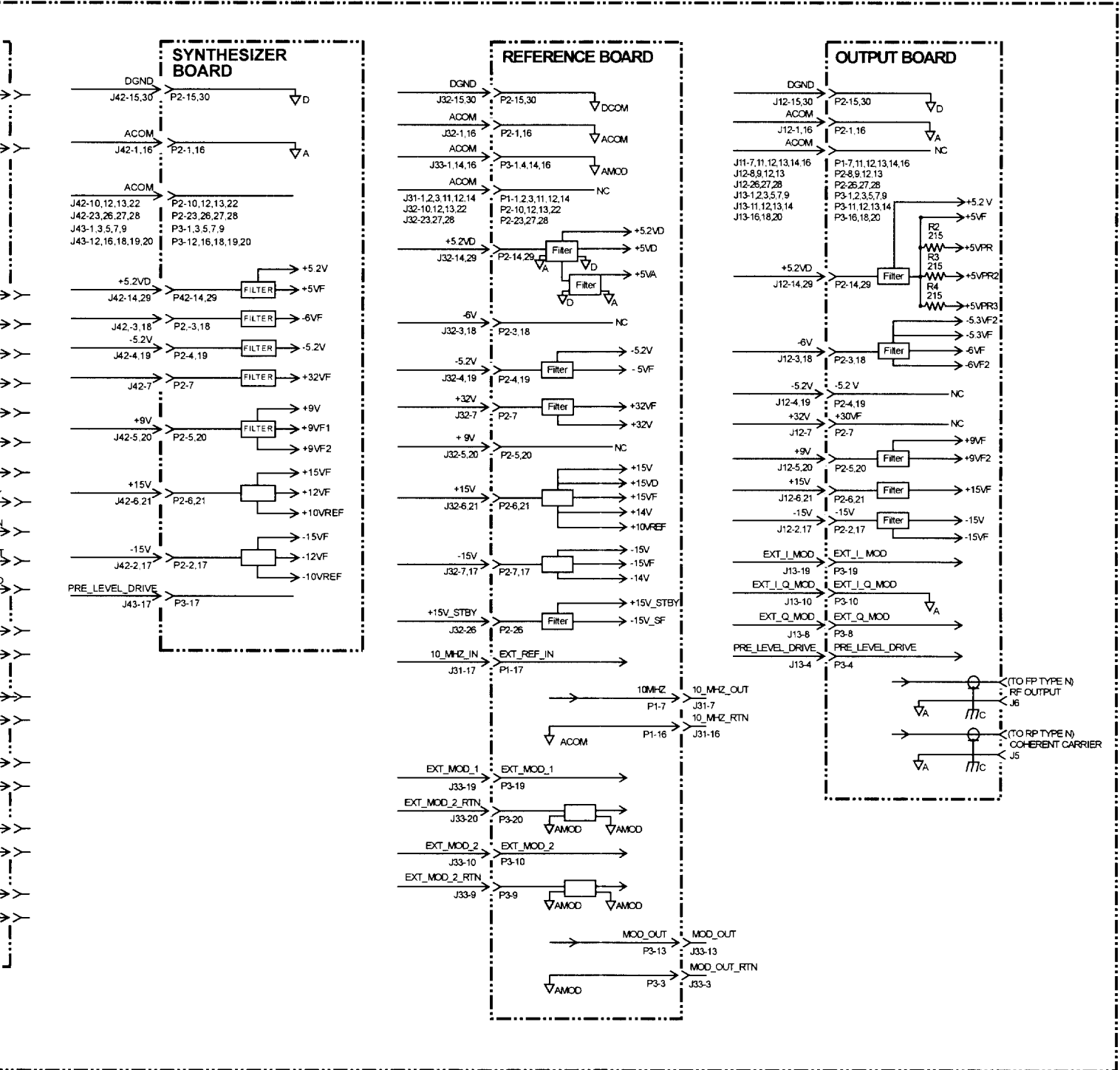

ESG-D SERIES POWER SUPPLY & GROUND INTERCONNECTS (1 OF 2)

ESG-A SERIES MODULATION AND SIGNAL INTERCONNECTS

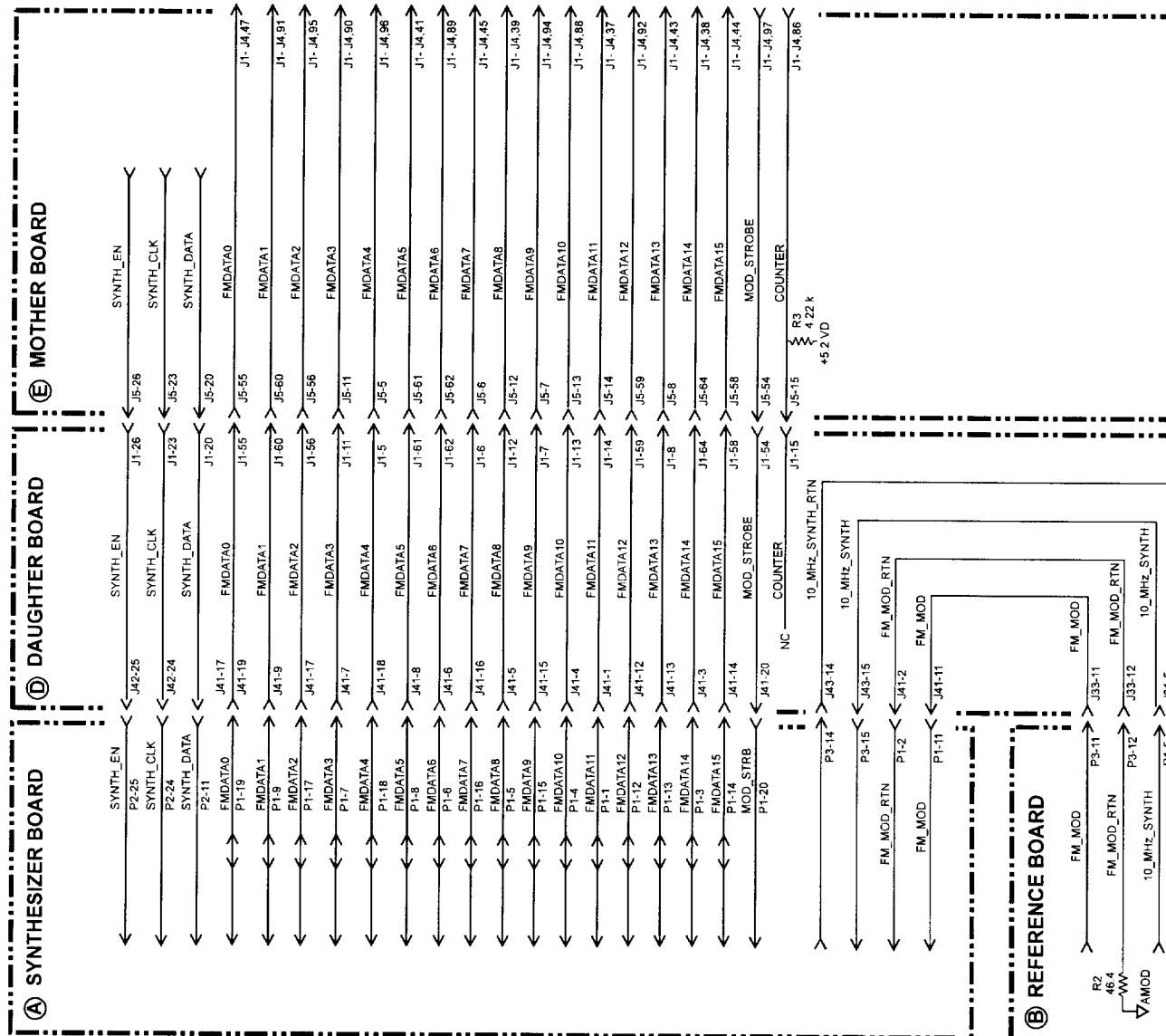

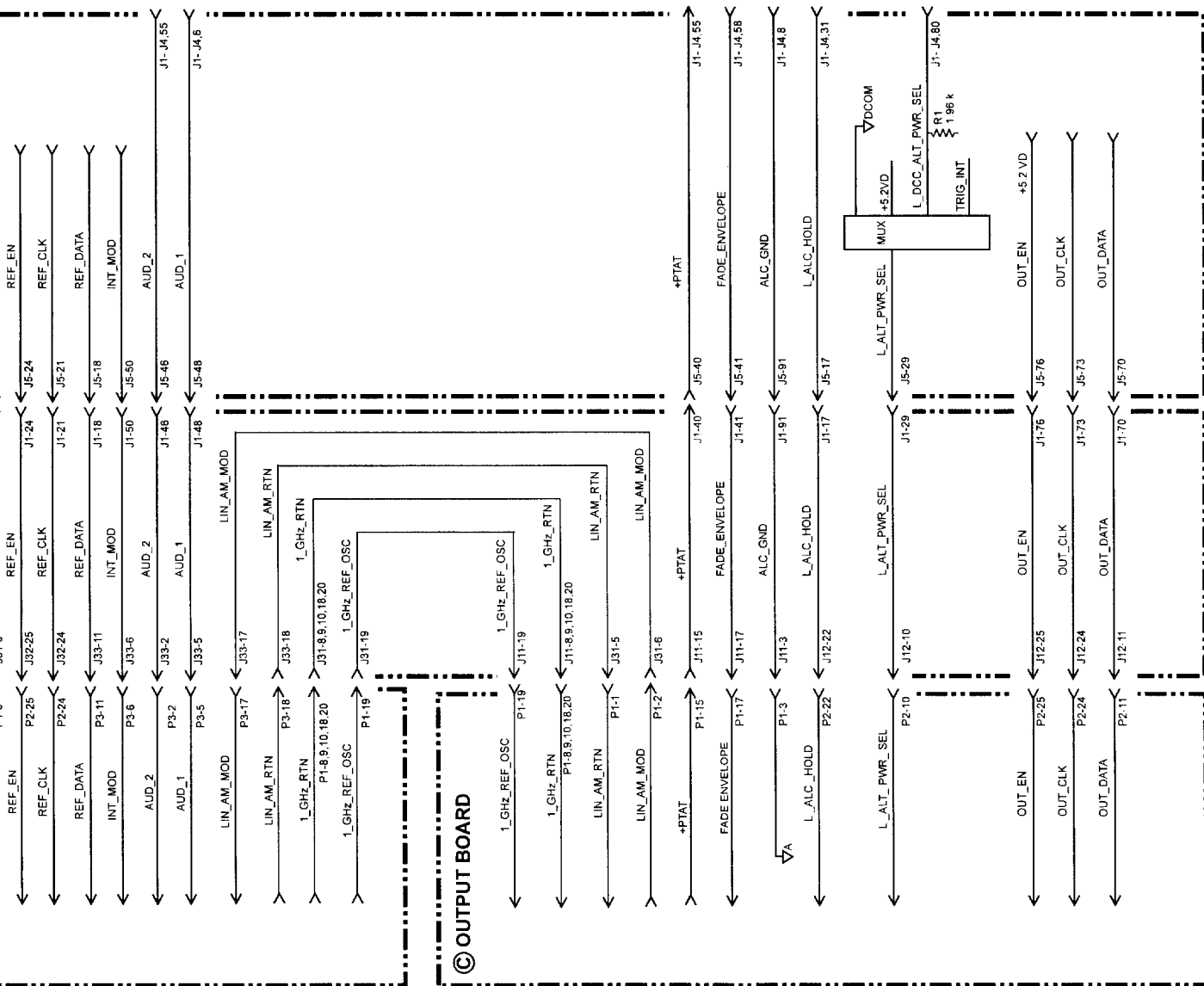

ESG-A SERIES MODULATION AND SIGNAL INTERCONNECTS

ESG-D SERIES MODULATION AND SIGNAL INTERCONNECTS (1 of 2)

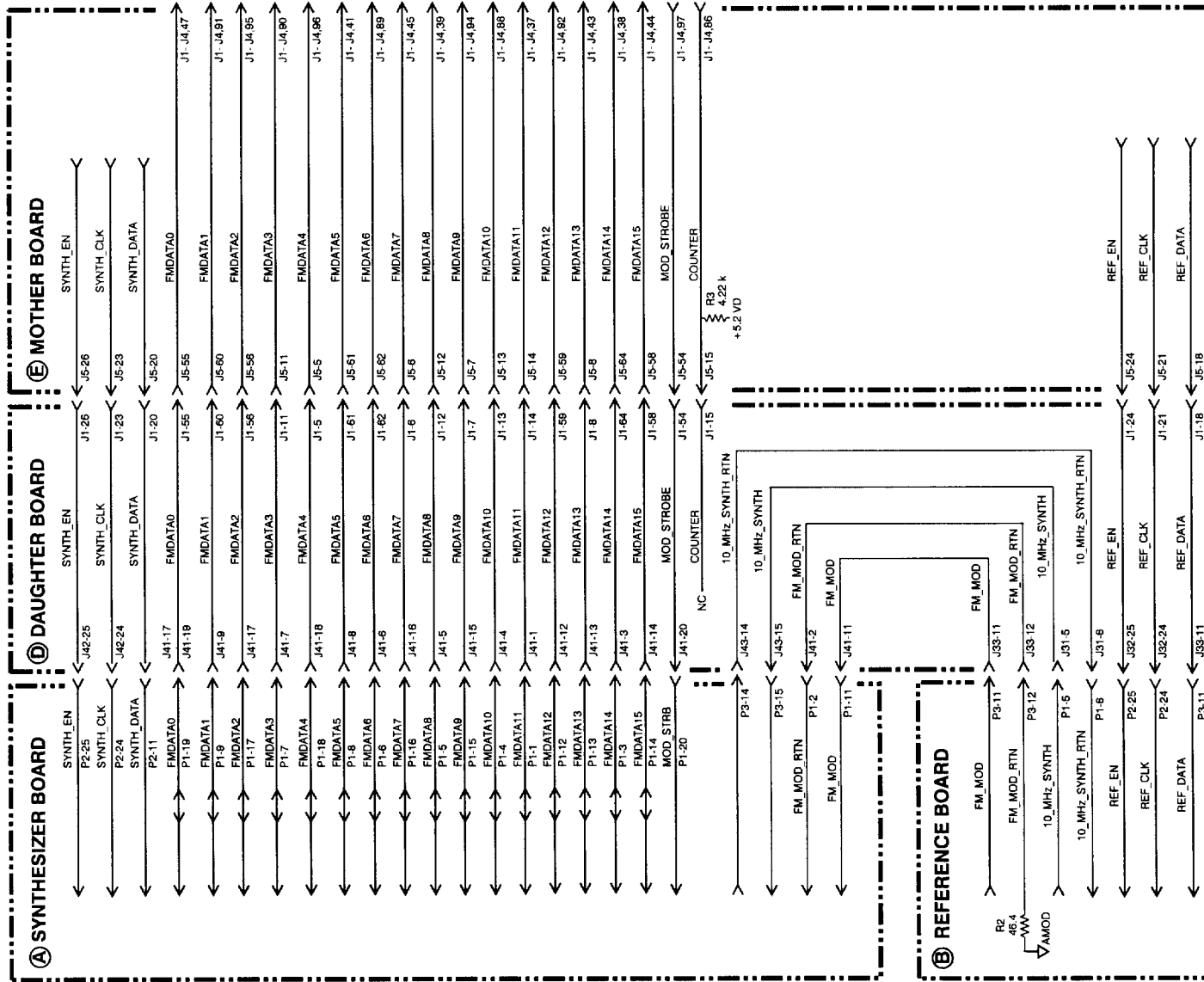

A12 SYNTH/DOUBLER BLOCK DIAGRAM

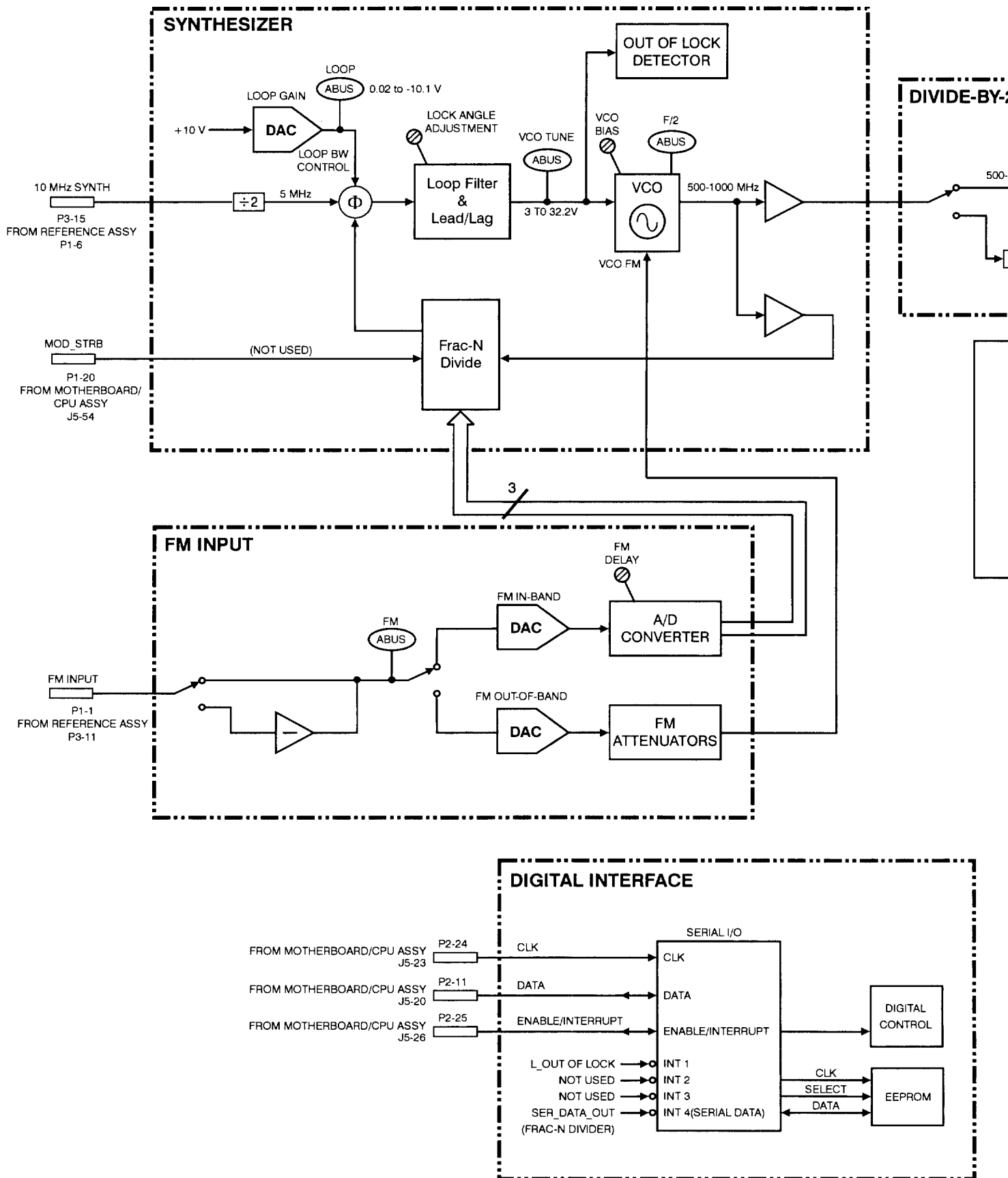

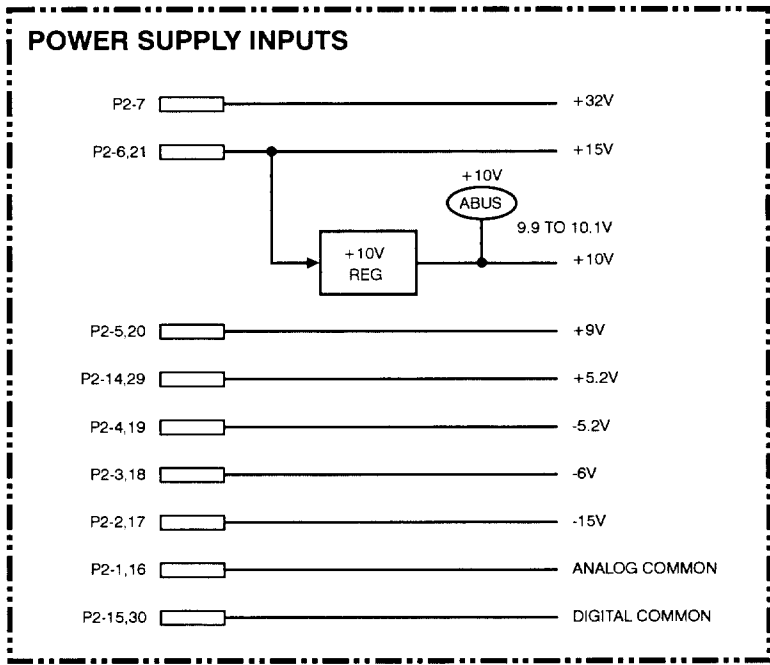
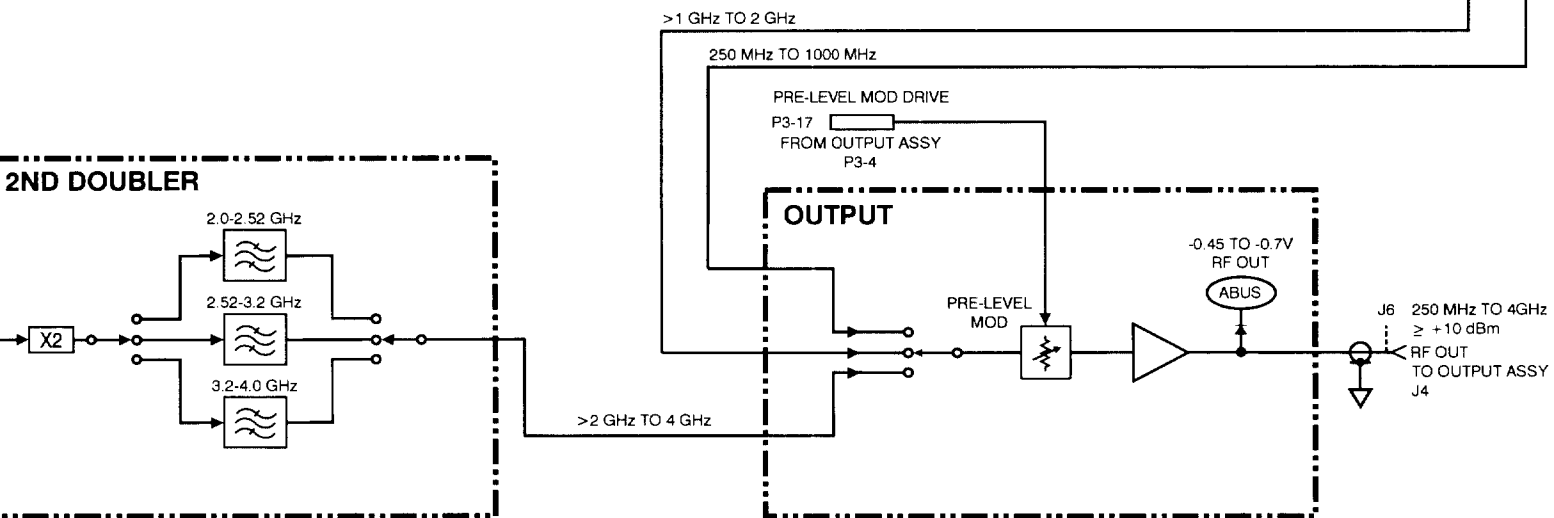
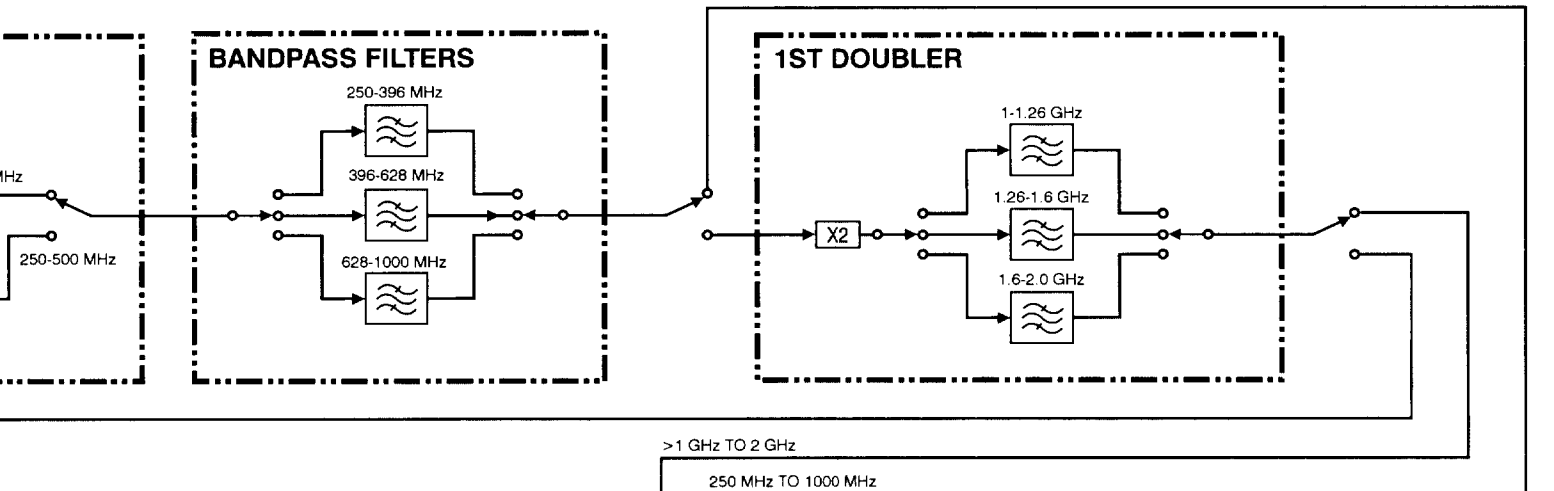

A12 SYNTH/DOUBLER BLOCK DIAGRAM

ESG-D SERIES POWER SUPPLY & GROUND INTERCONNECTS (2 OF 2)

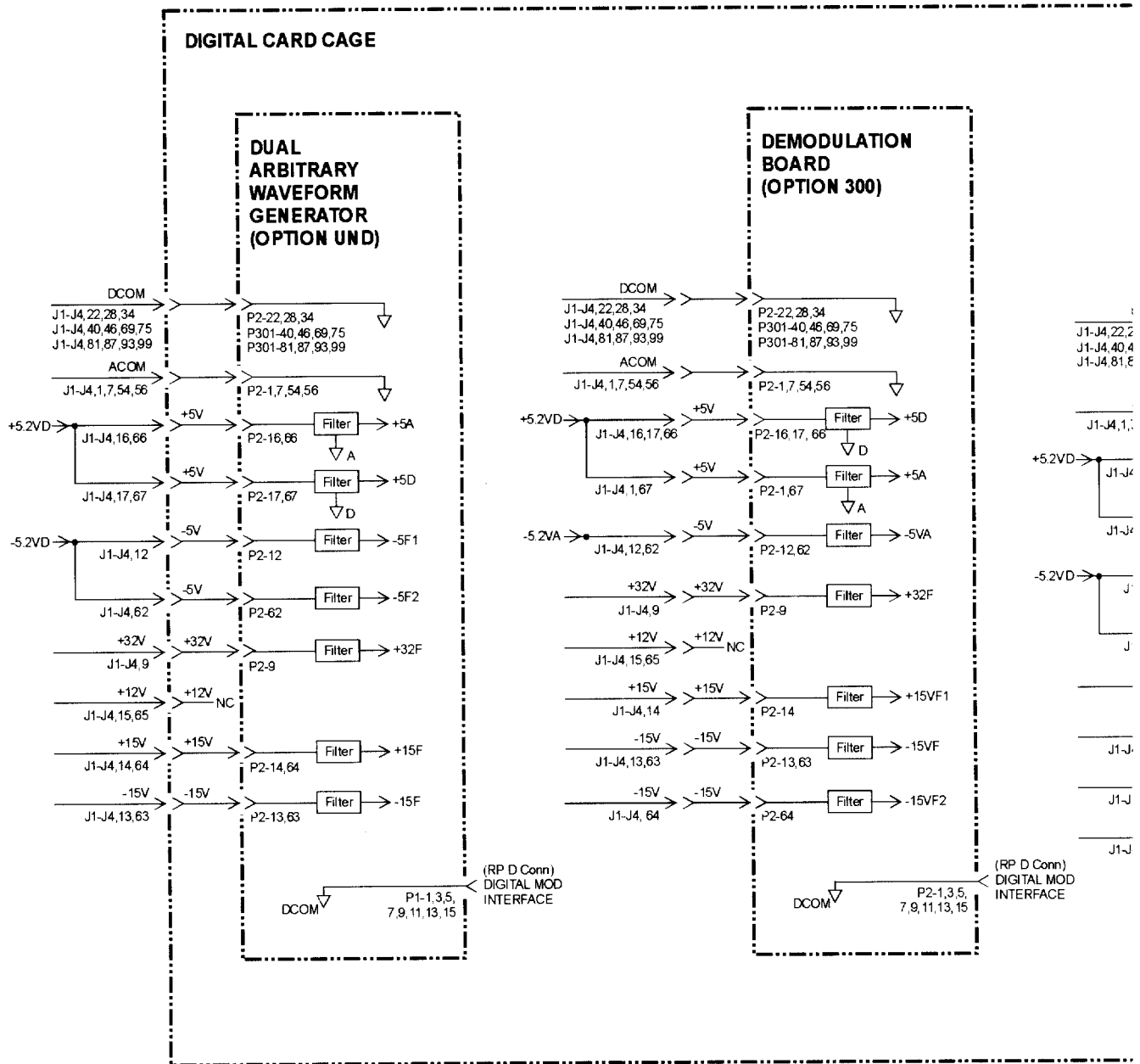

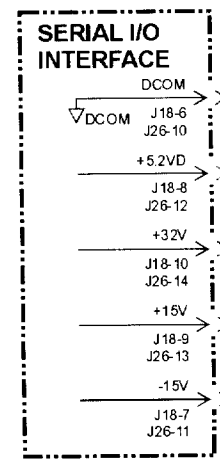
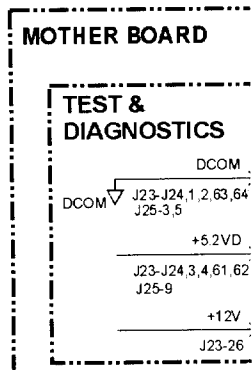
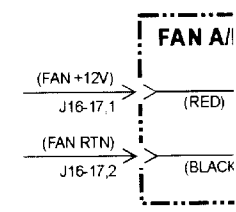
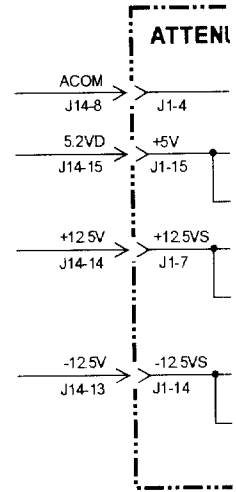
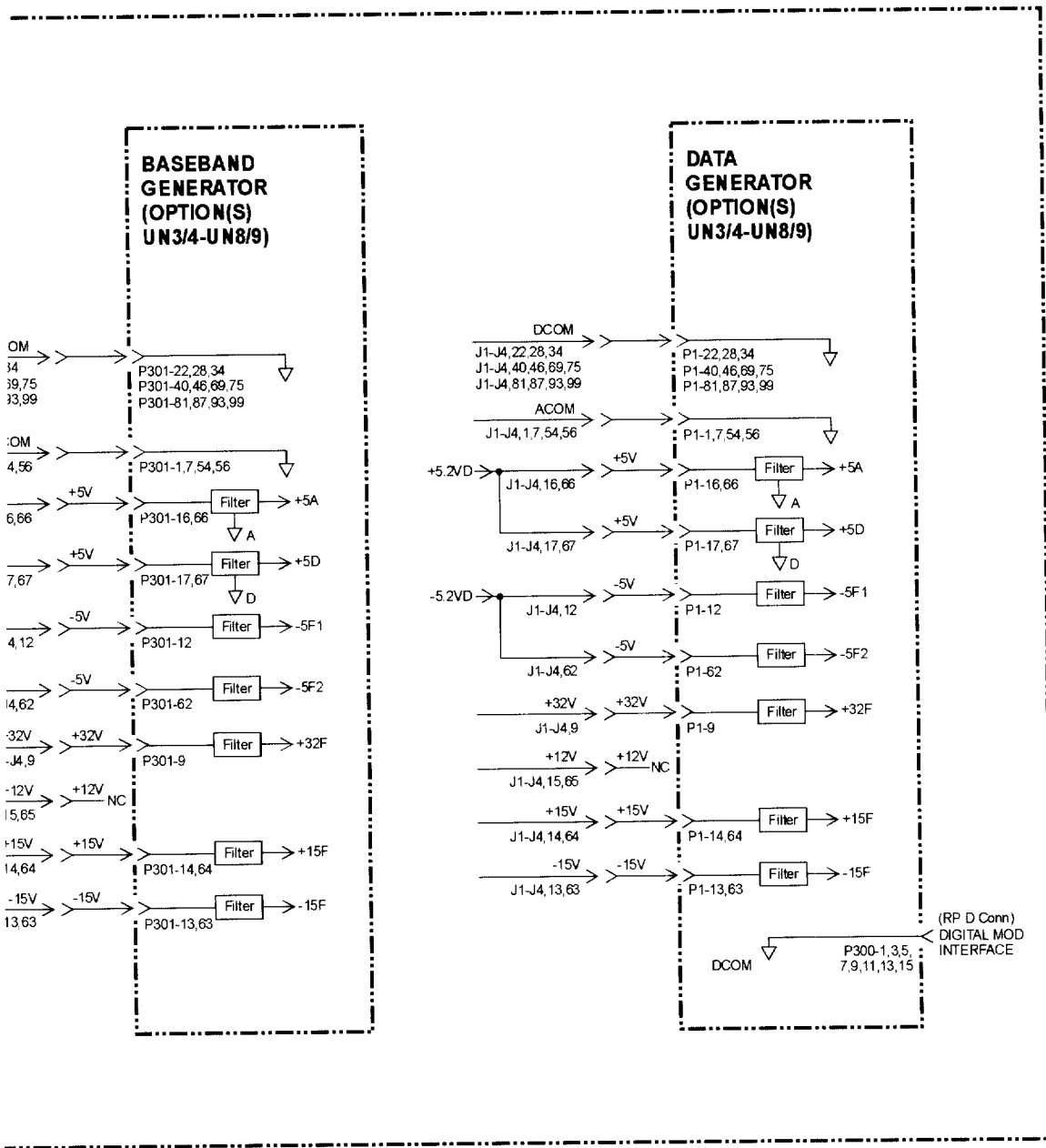

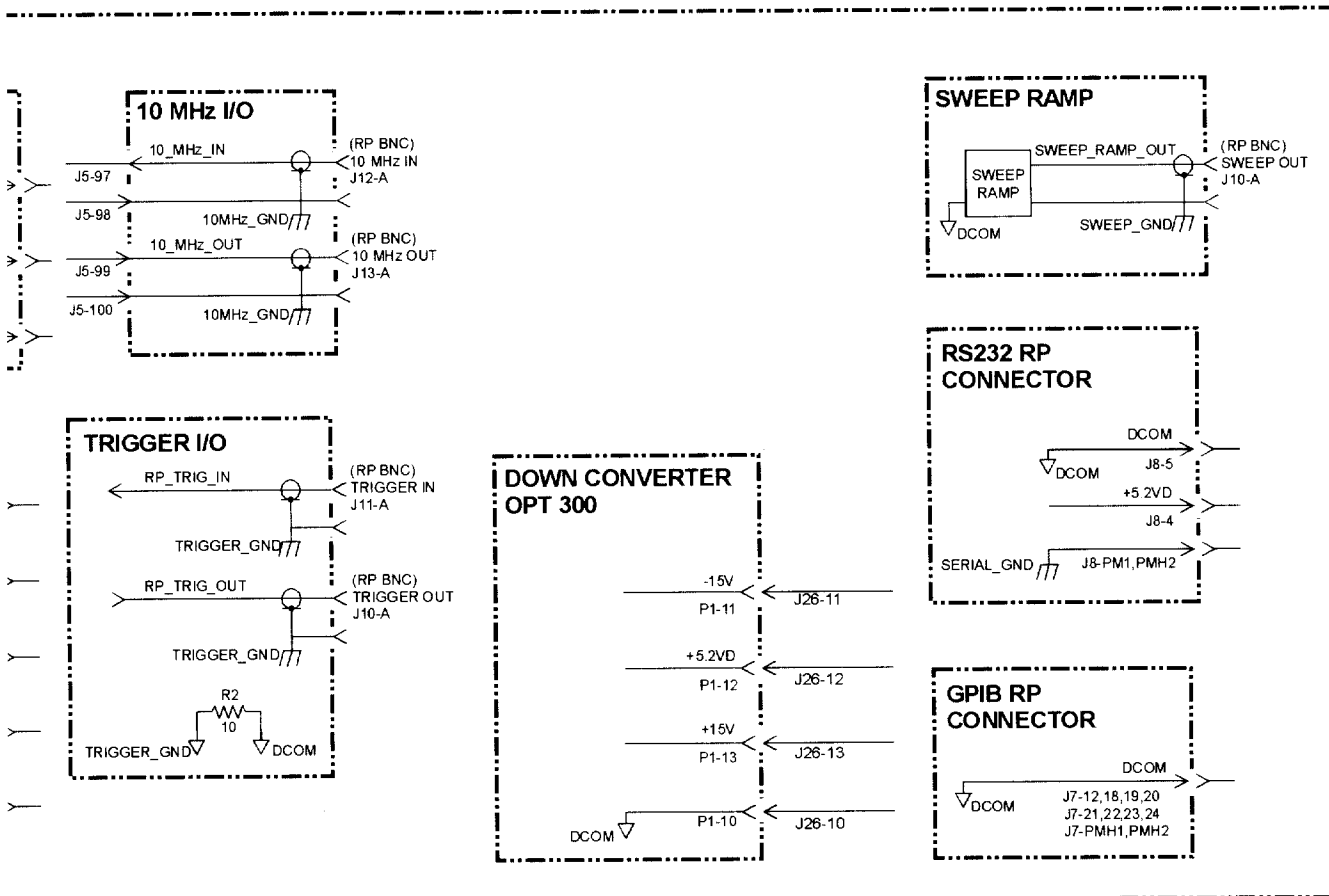
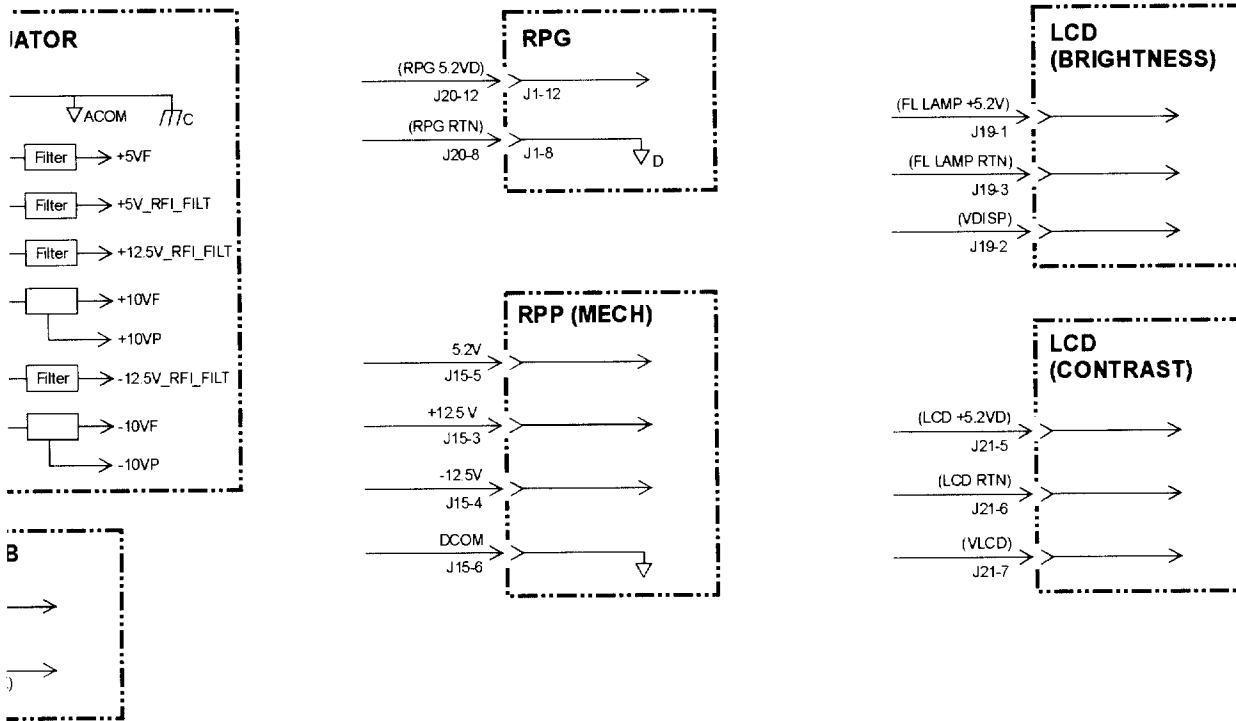

ESG-AP SERIES RF BLOCK DIAGRAM (STANDARD & 1E6)

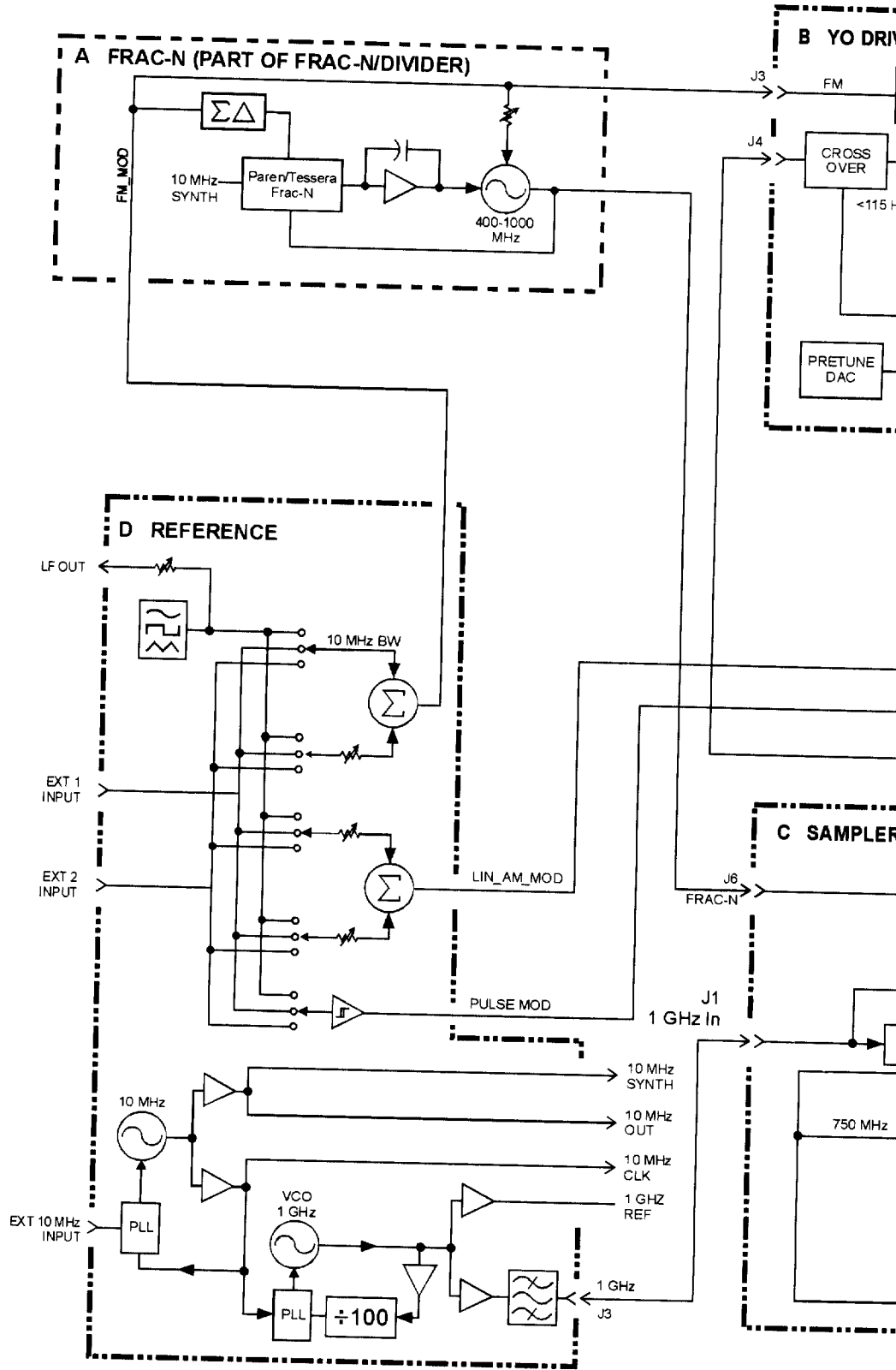

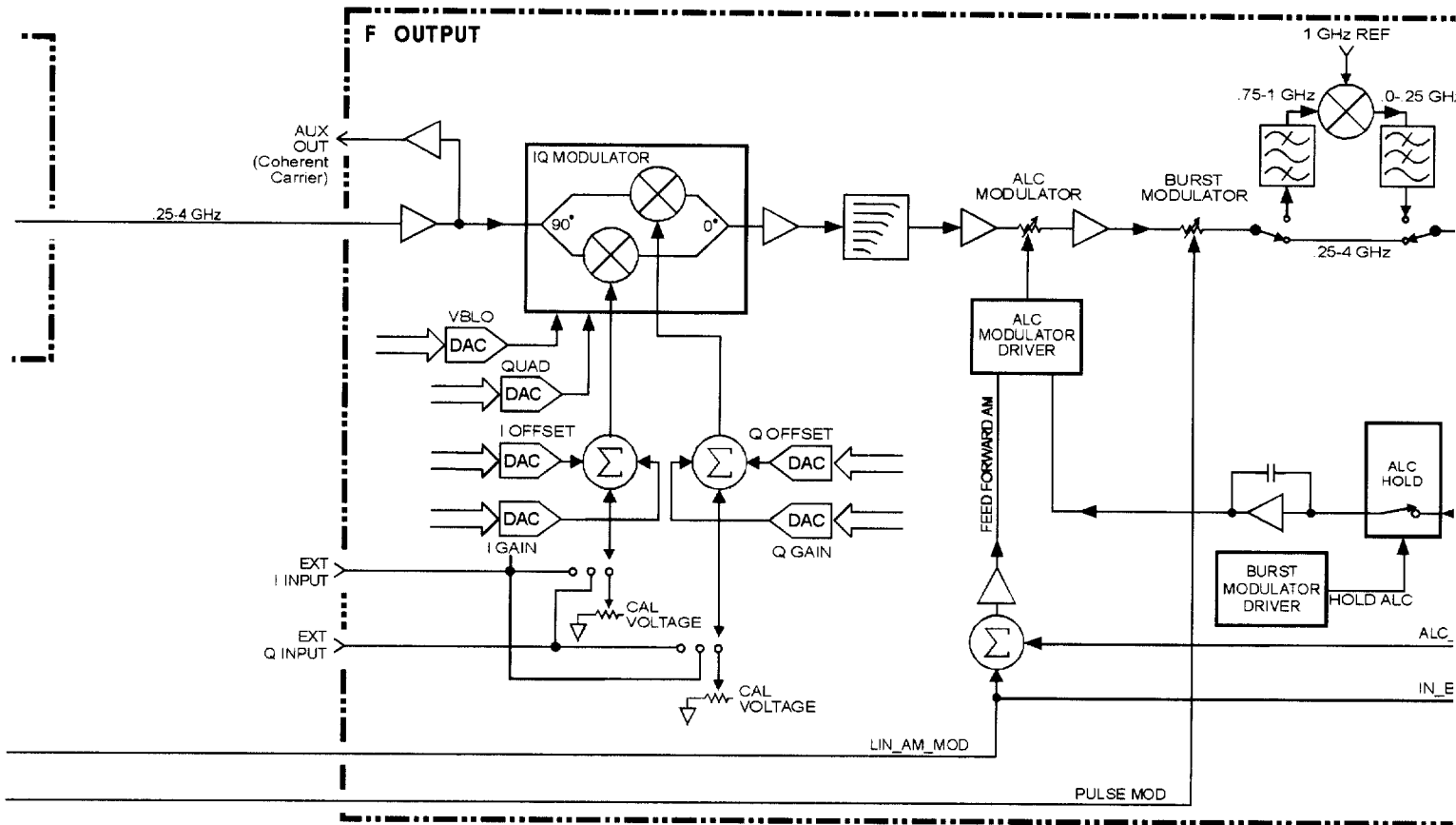

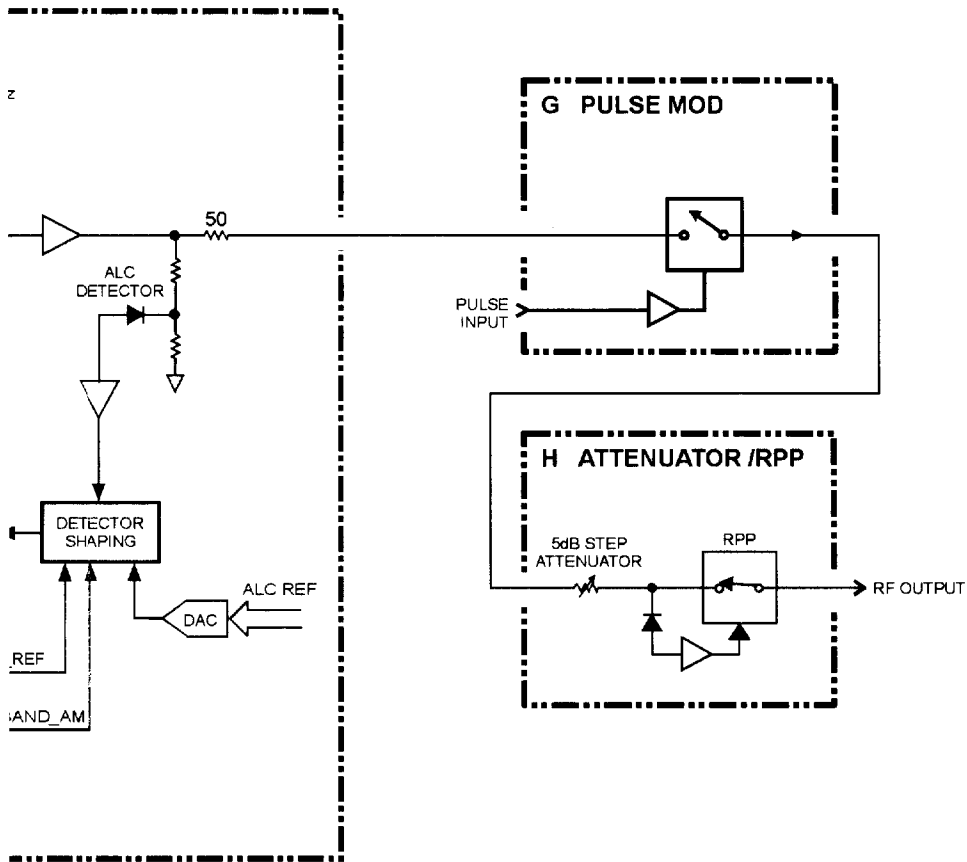

ESG-AP SERIES RF BLOCK DIAGRAM (STANDARD & 1E6)

ESG-DP SERIES RF BLOCK DIAGRAM

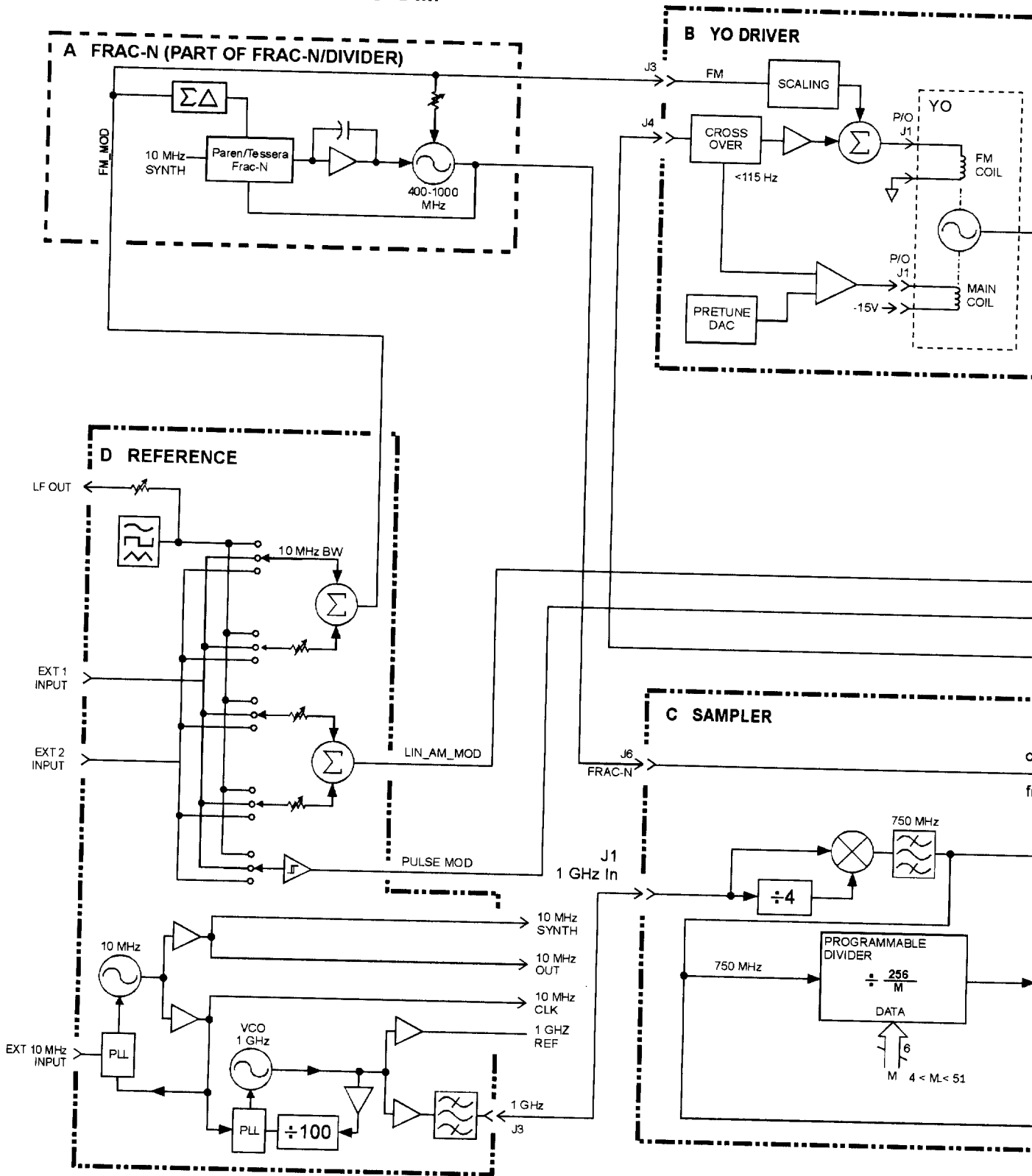

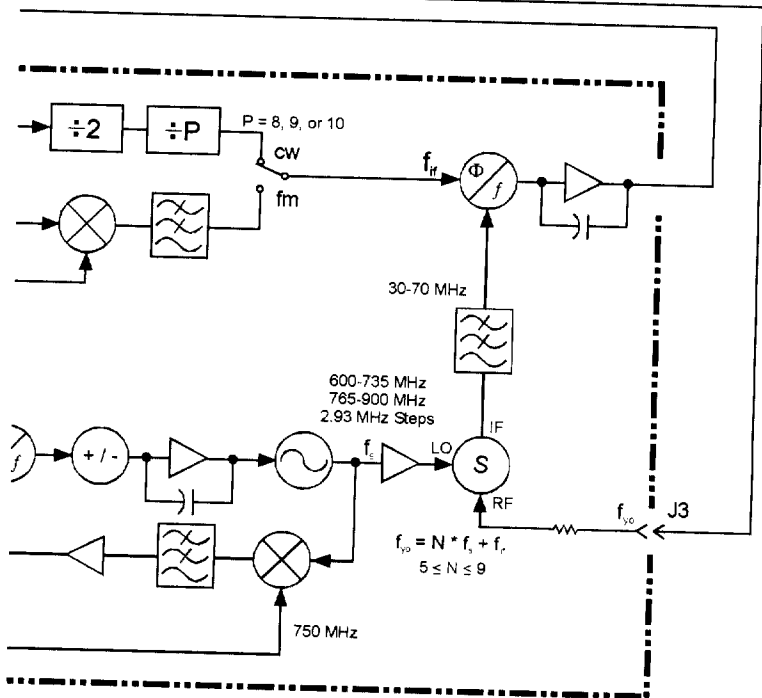
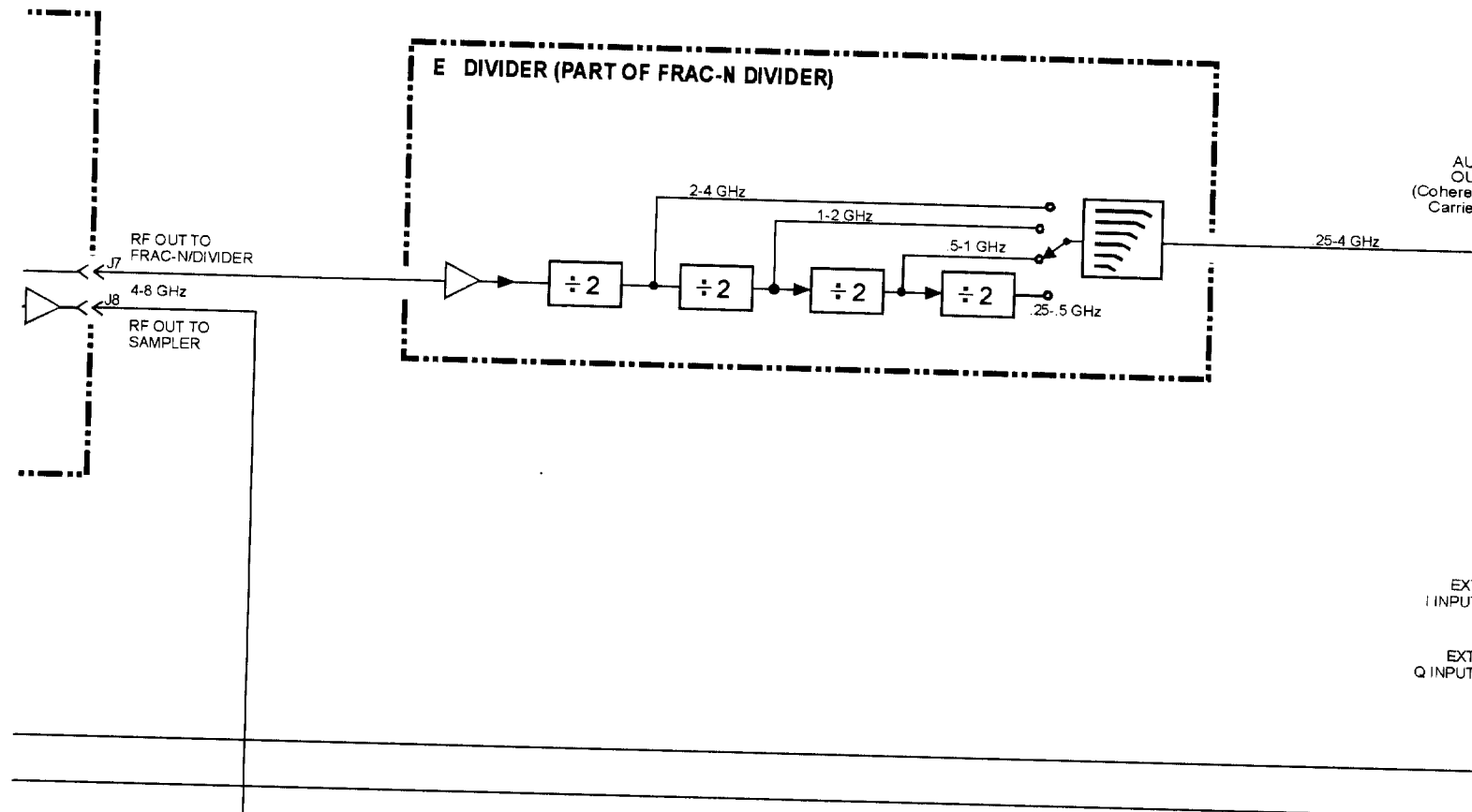

AL
QU
(Coheren
Carrie

EX
I INPUT

EXT
Q INPUT

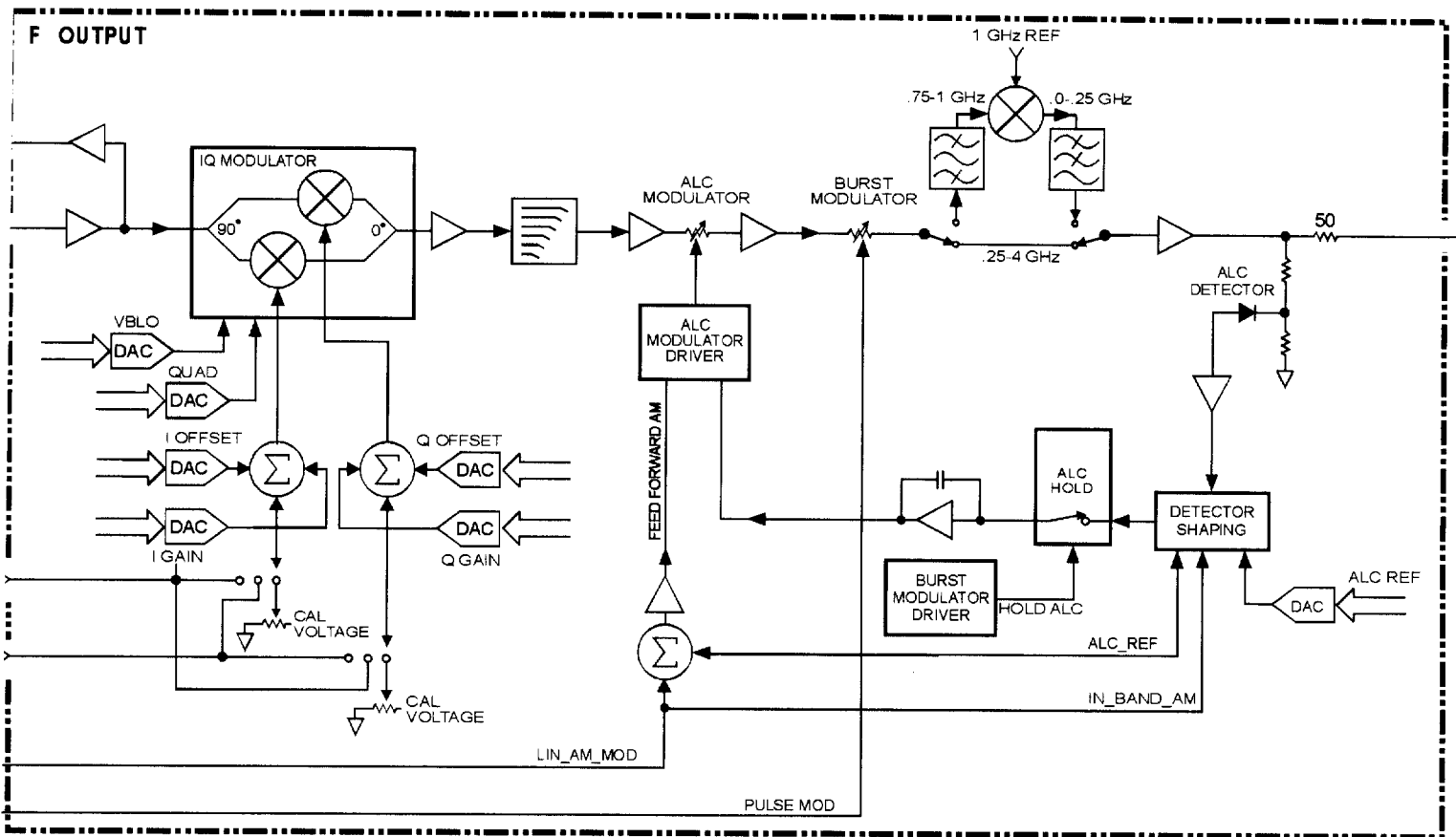

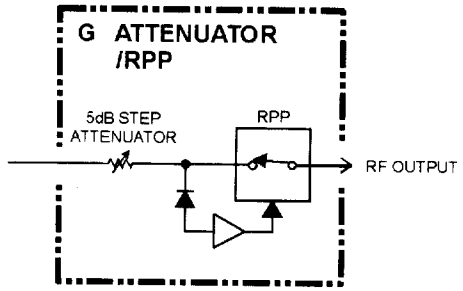

ESG-DP SERIES RF BLOCK DIAGRAM

ESG-DP SERIES RF BLOCK DIAGRAM (OPTION UN7)

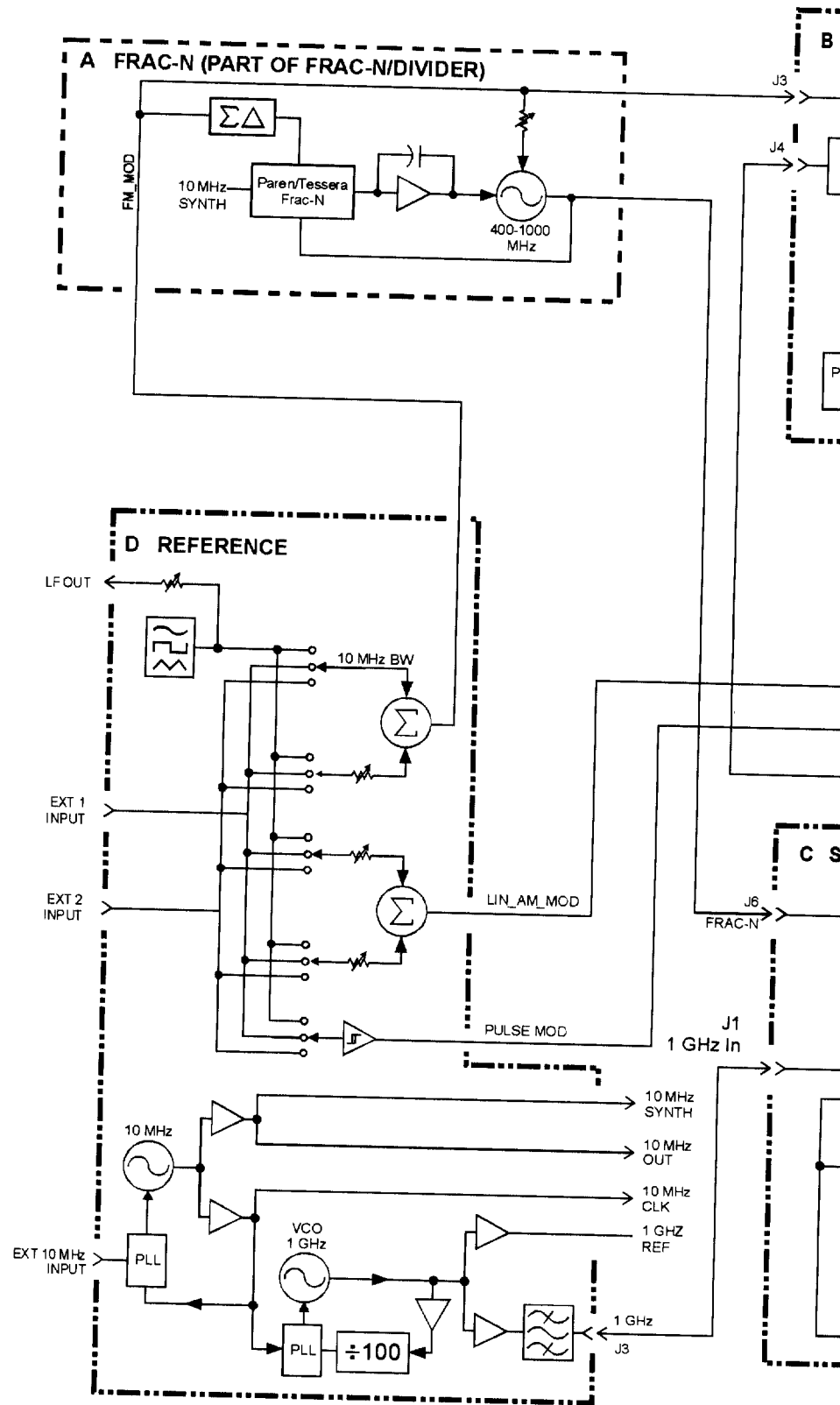

DRIVER

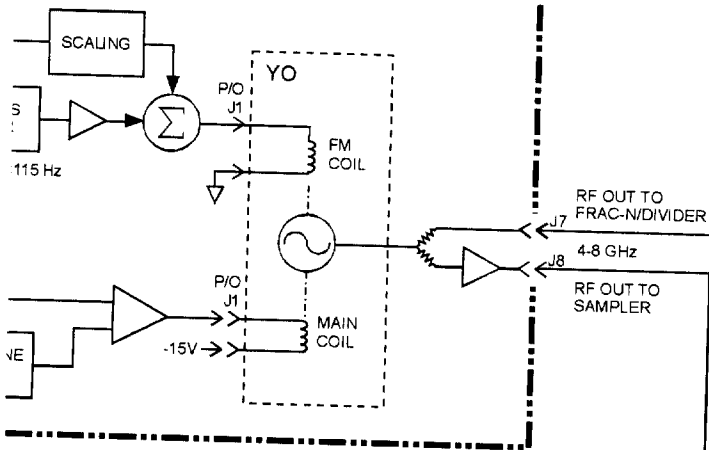

E DIVIDER (PART OF FRAC-N DIVIDER)

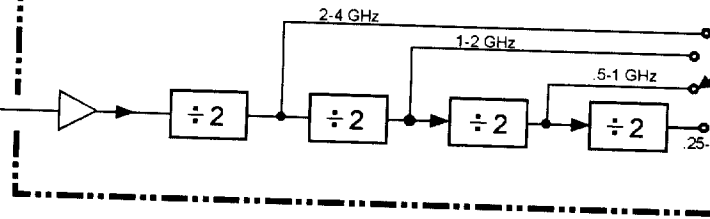

PLER

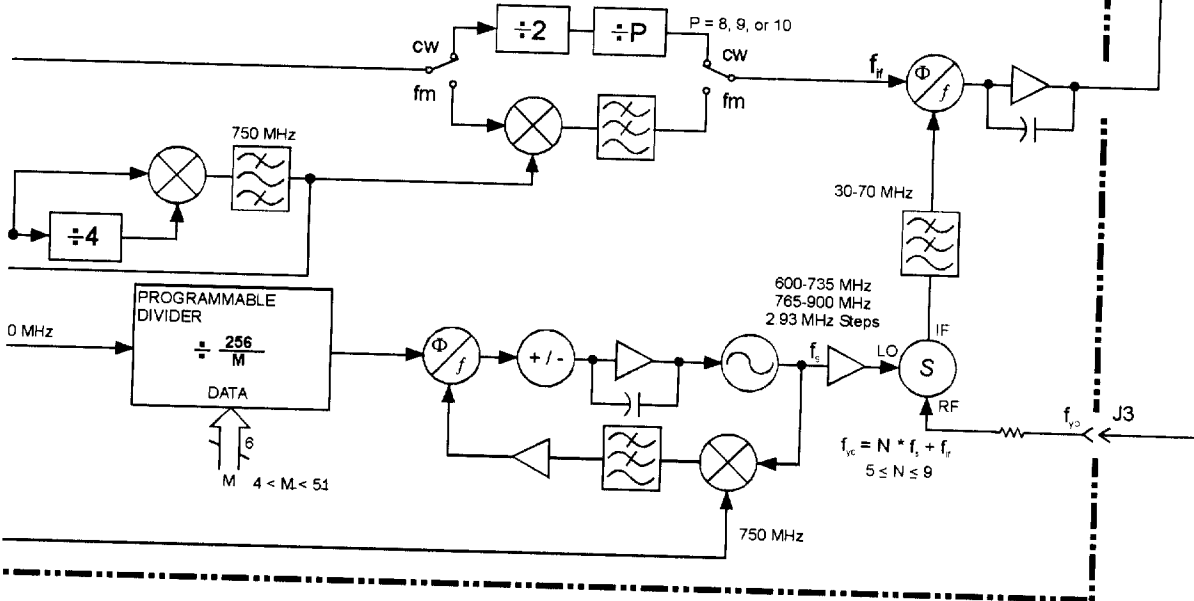

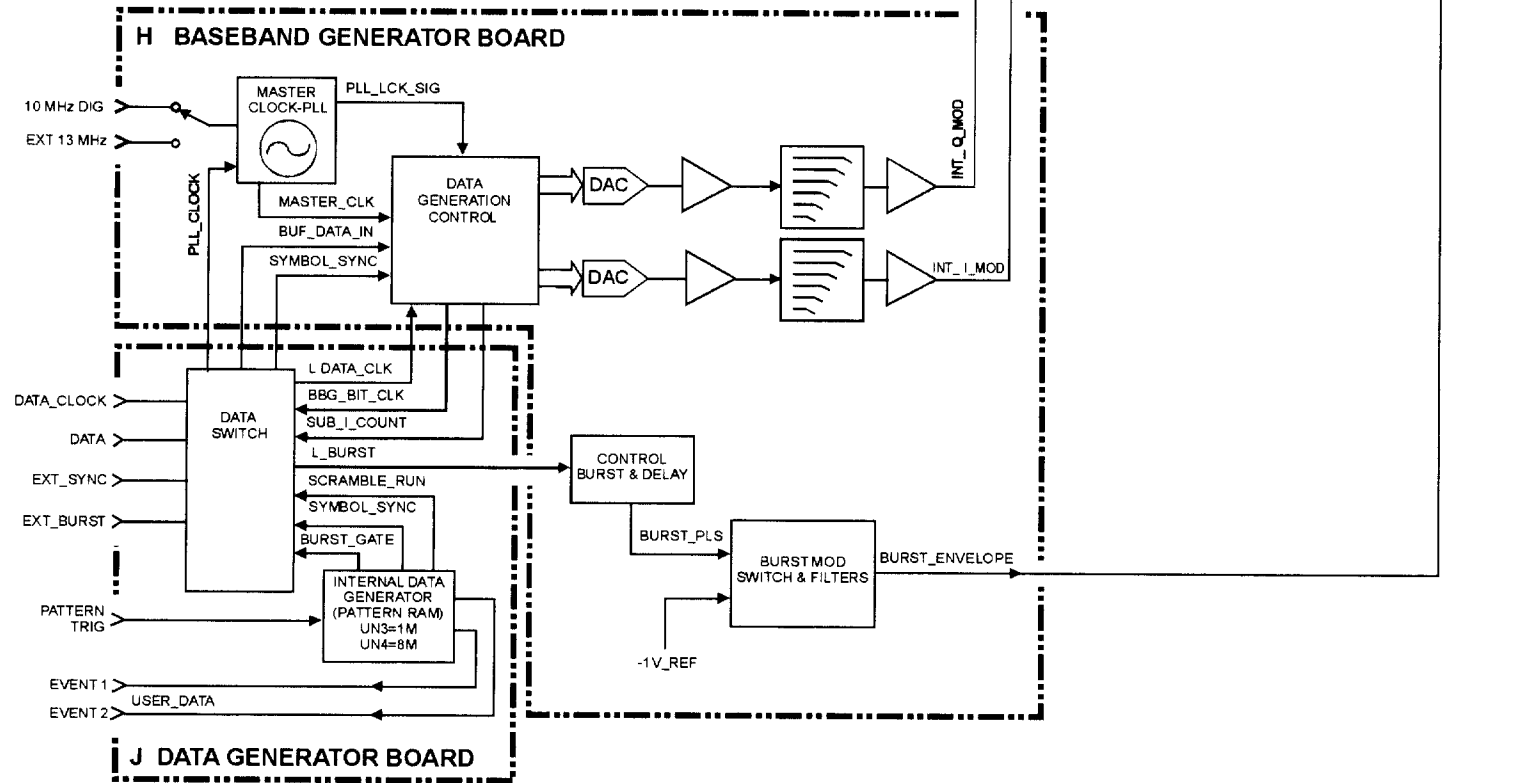
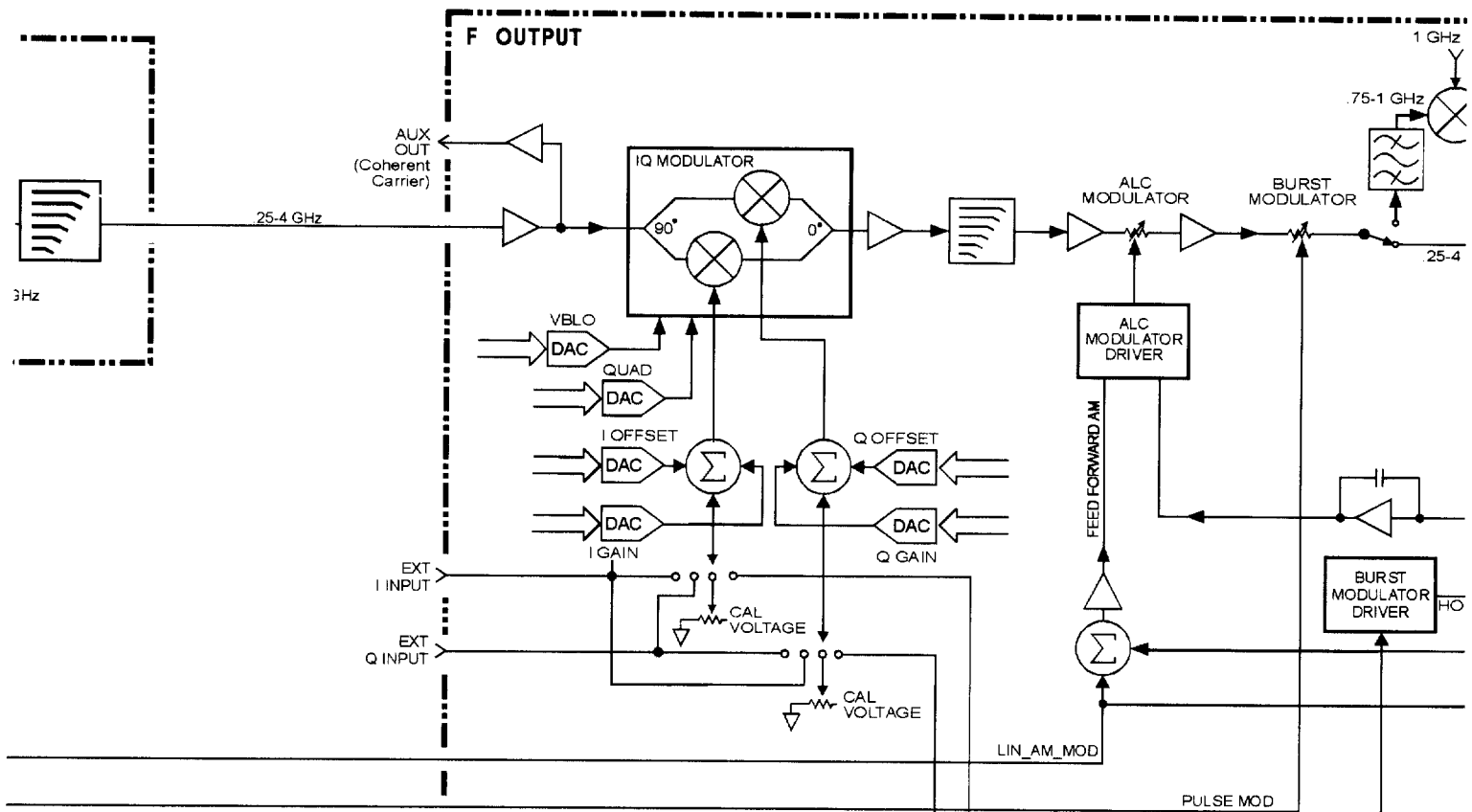

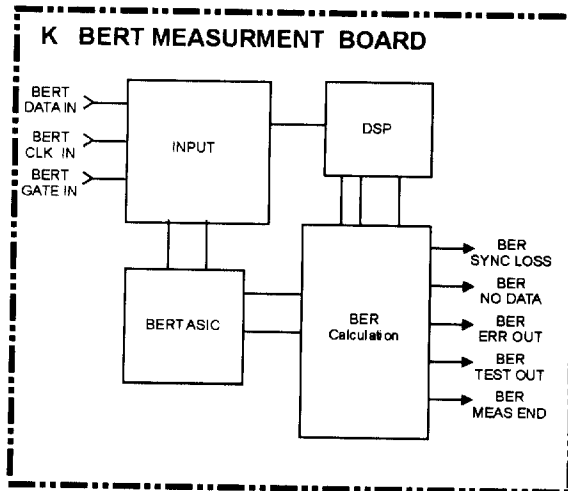
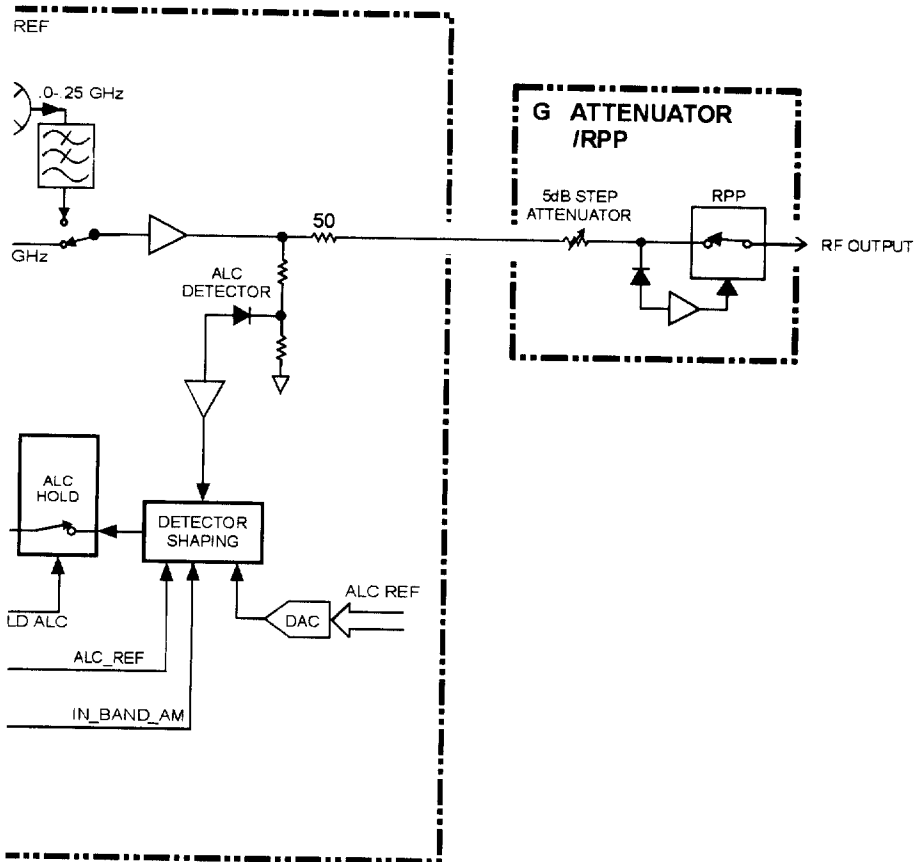

ESG-DP SERIES RF BLOCK DIAGRAM (OPTION UN7)

ESG-DP SERIES RF BLOCK DIAGRAM (OPTIONS UN8 & UN9)

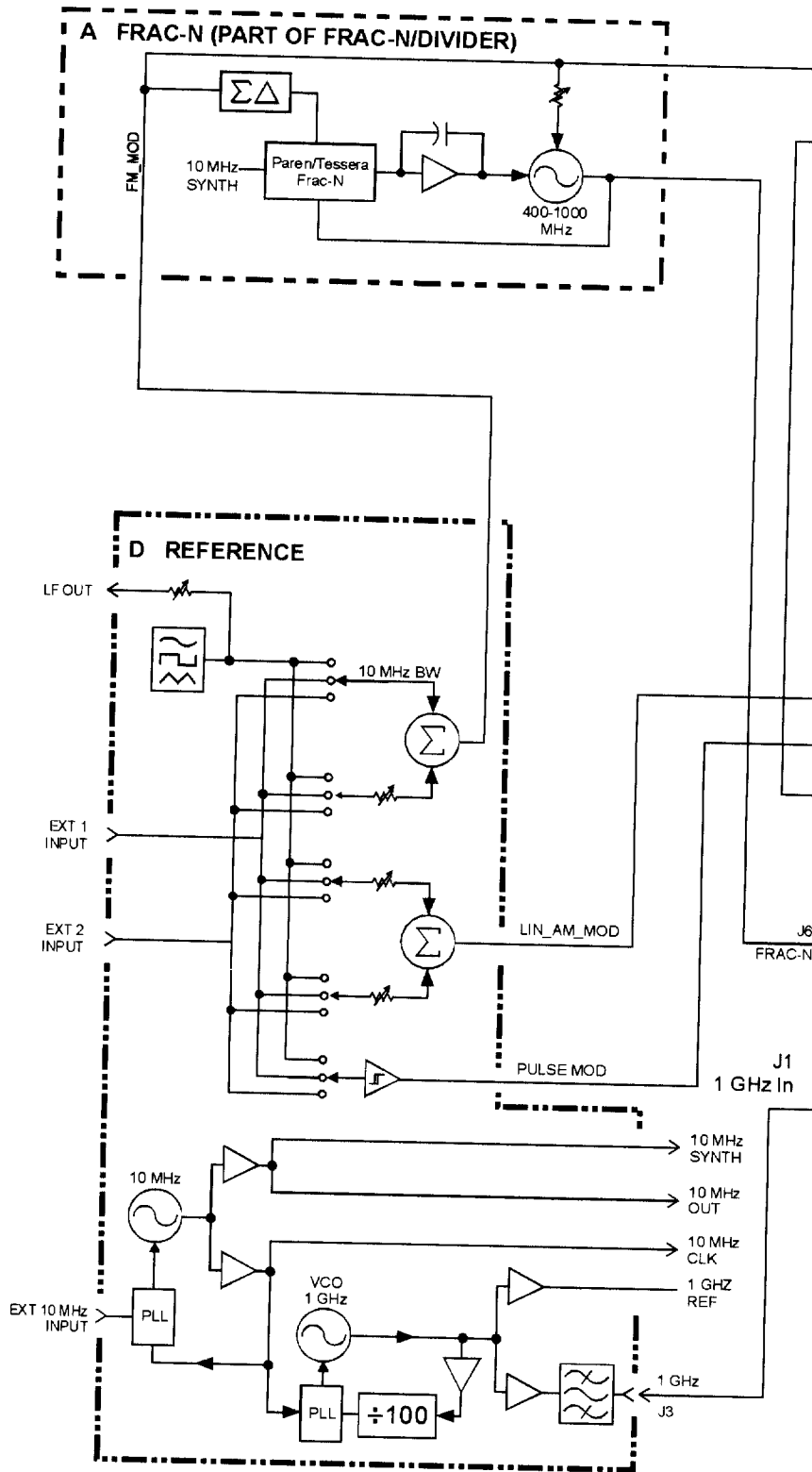

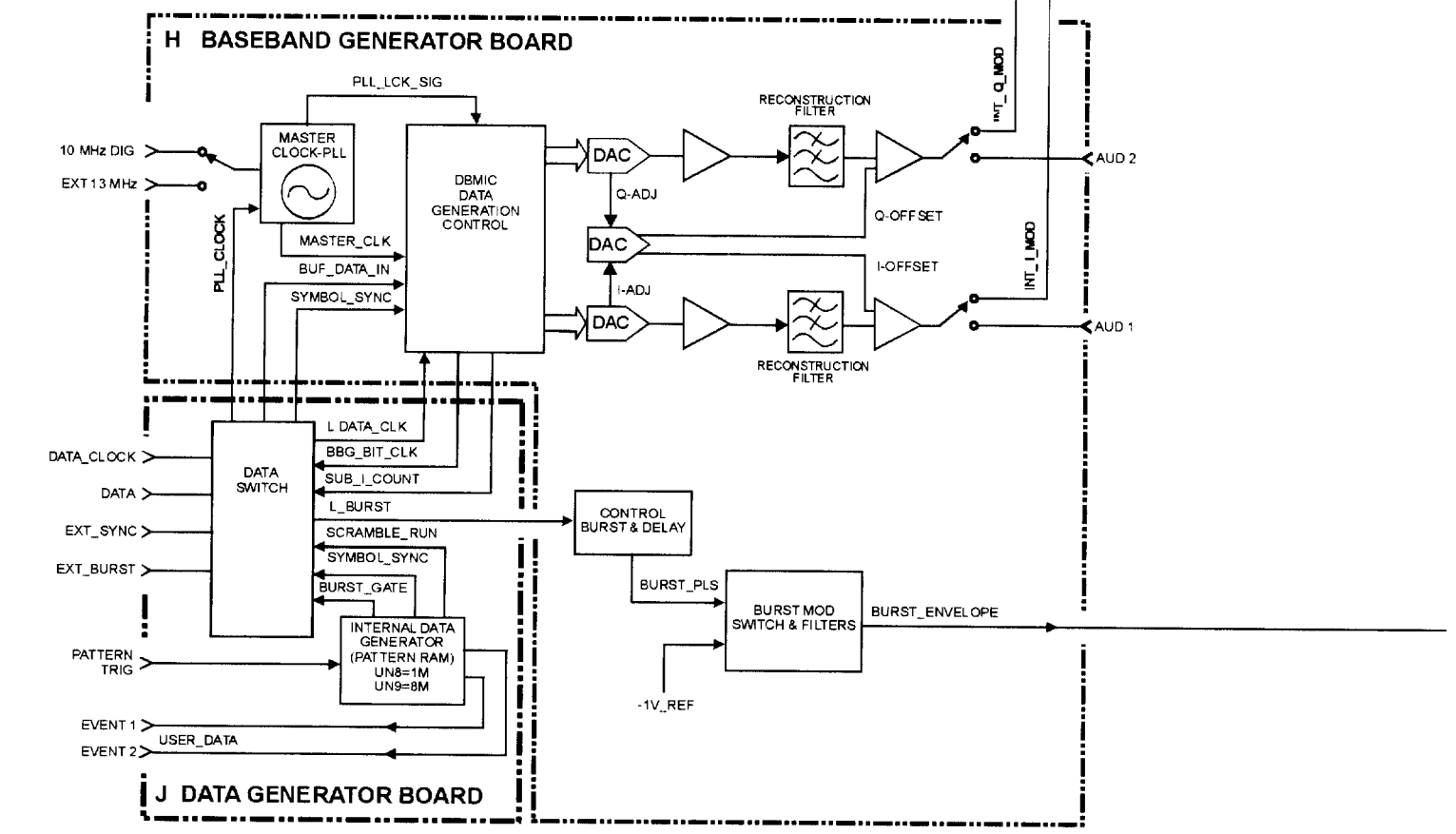
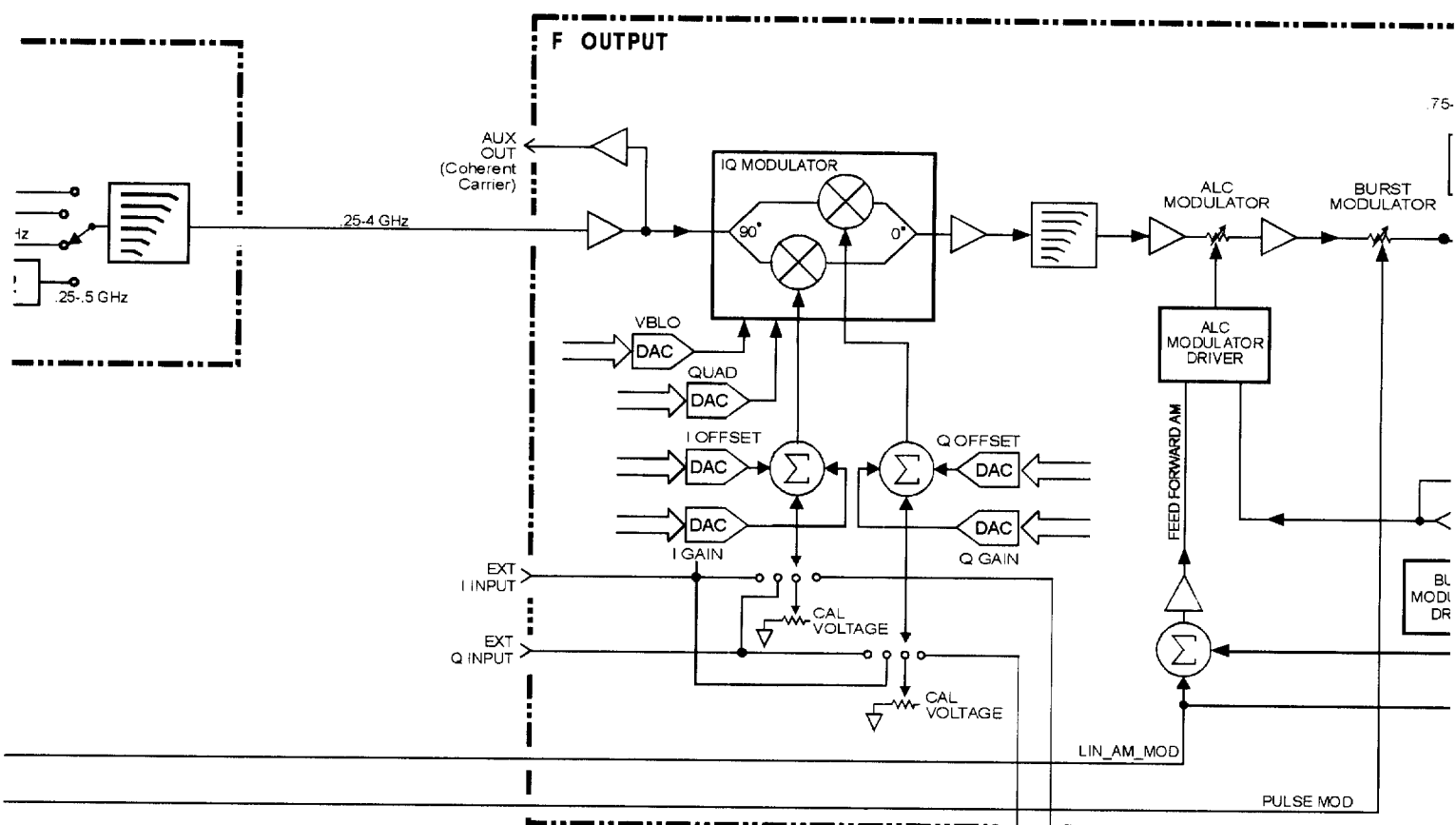

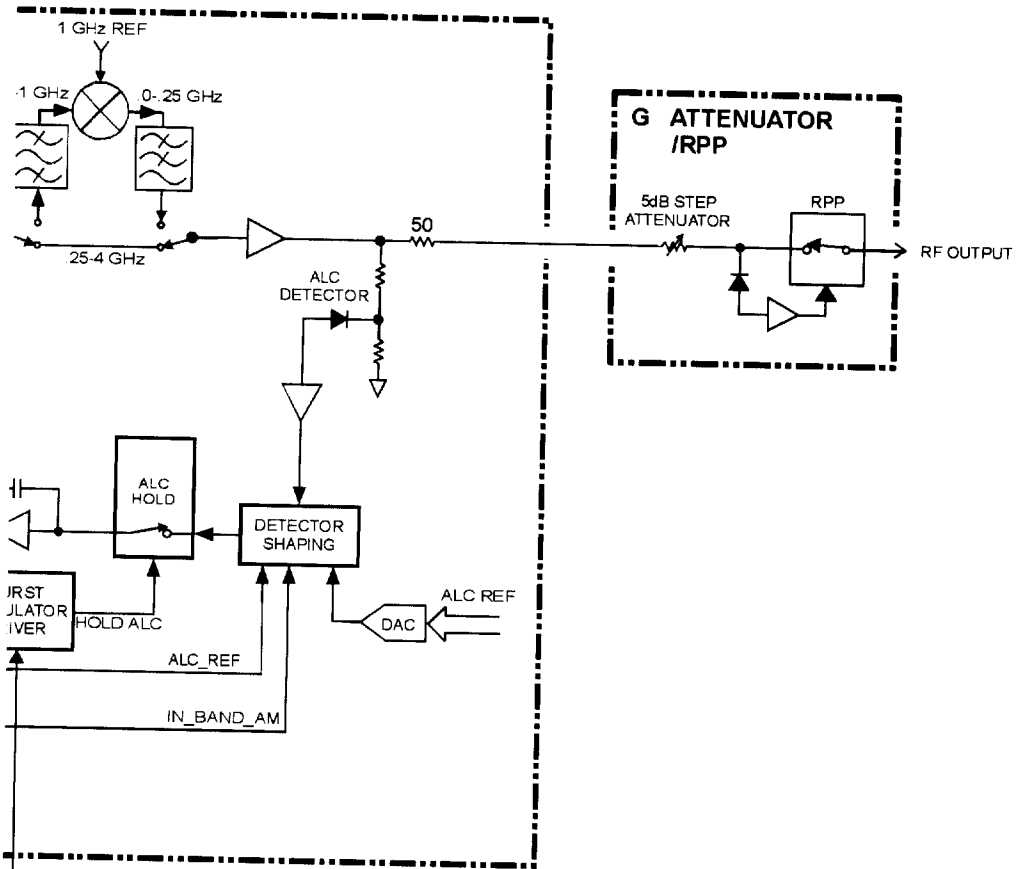

ESG-DP SERIES RF BLOCK DIAGRAM (OPTIONS UN8 & UN9)

ESG-DP SERIES RF BLOCK DIAGRAM (OPTION UND)

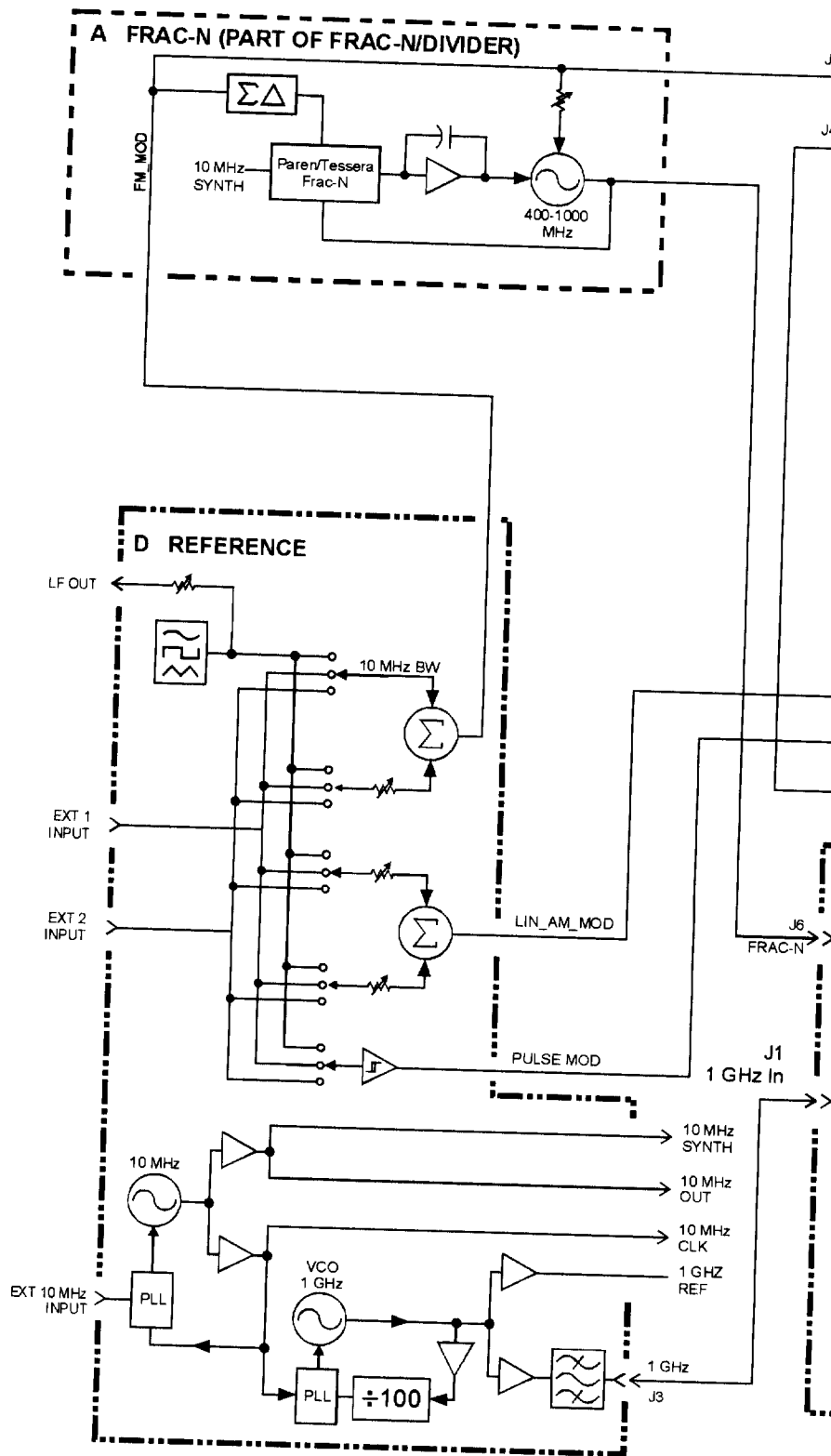

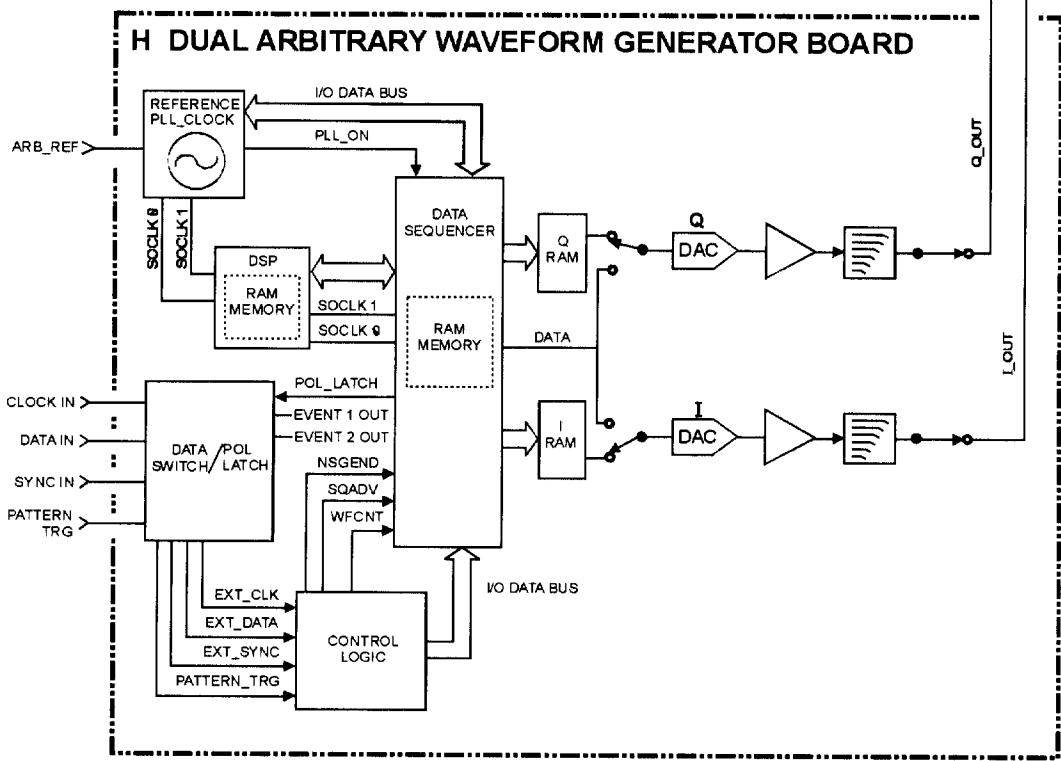
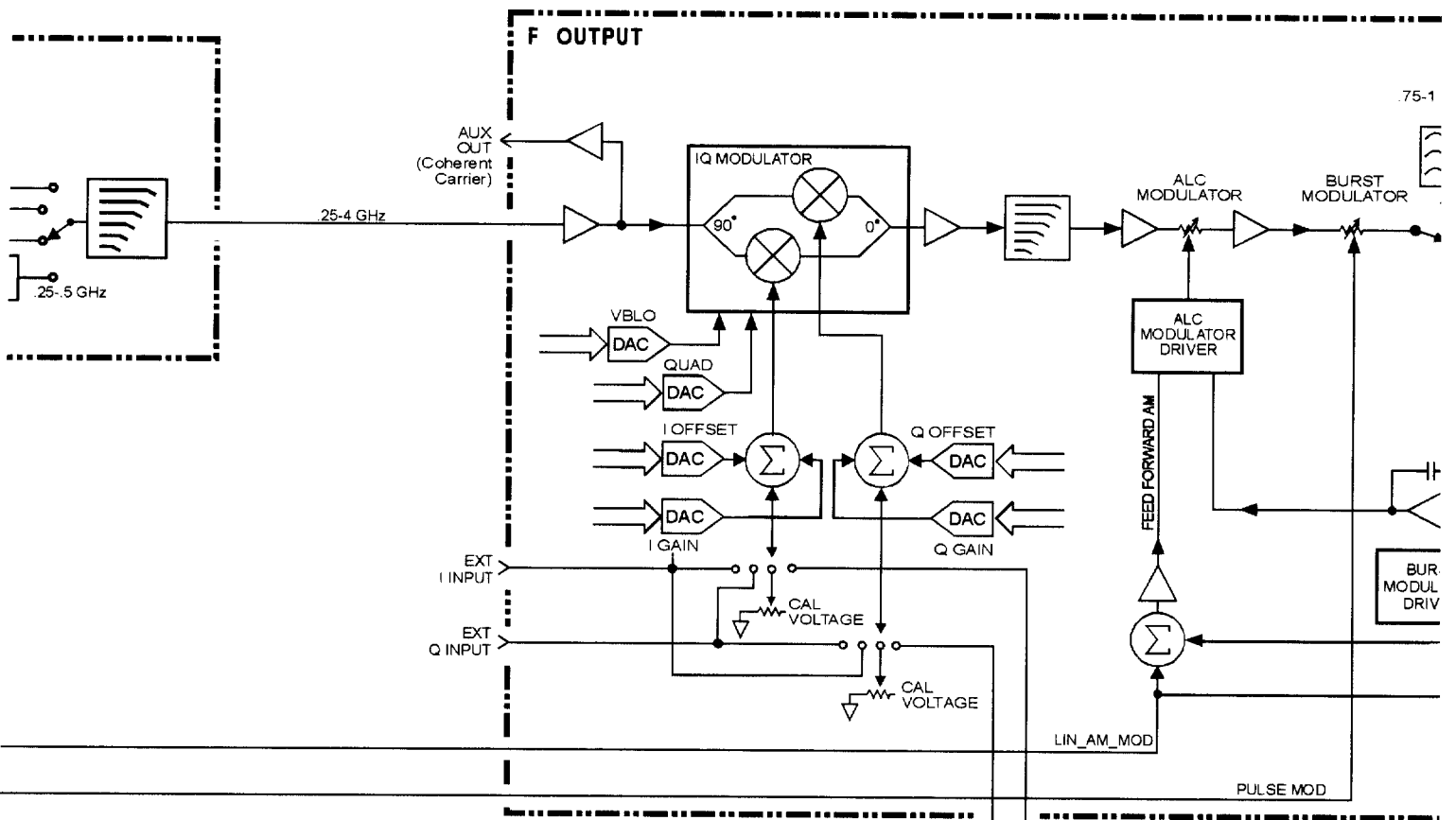

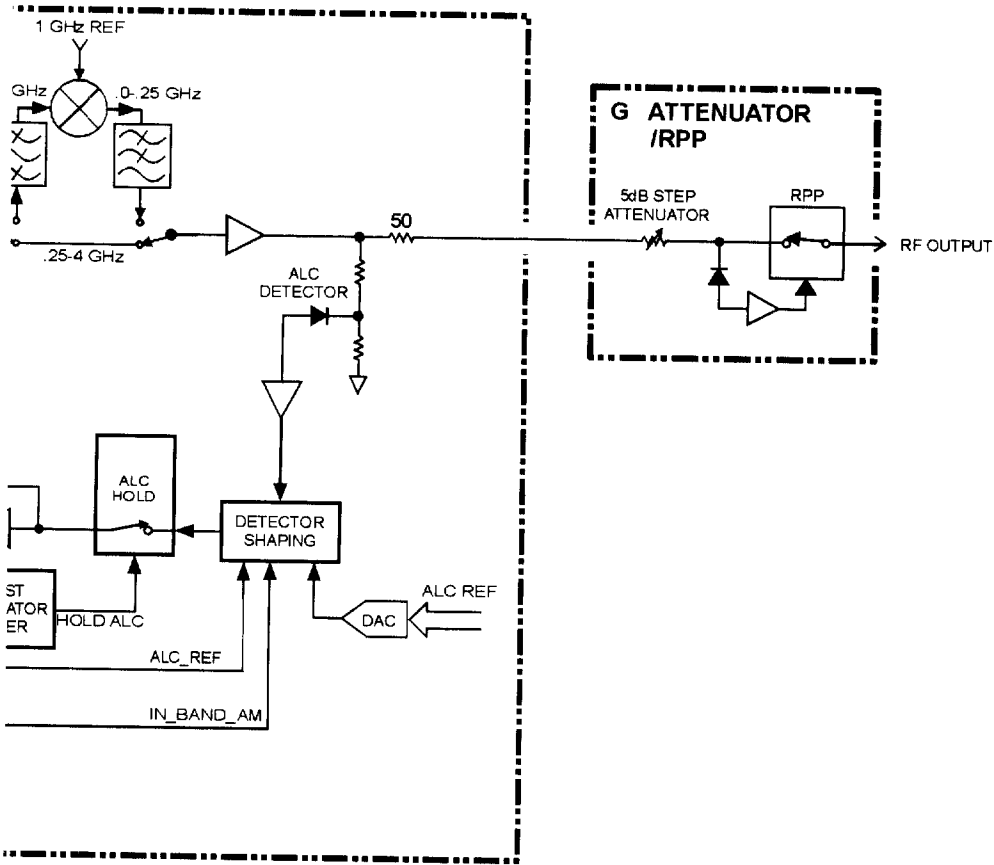

ESG-DP SERIES RF BLOCK DIAGRAM (OPTION UND)

A5 DUAL ARBITRARY WAVEFORM GENERATOR BLOCK DIAGRAM (OPTION UND)

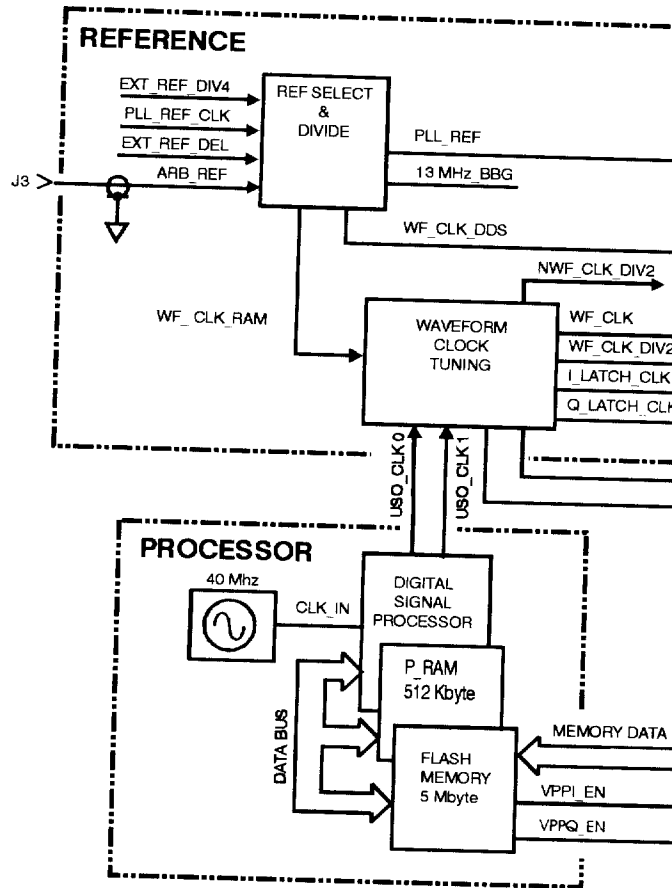
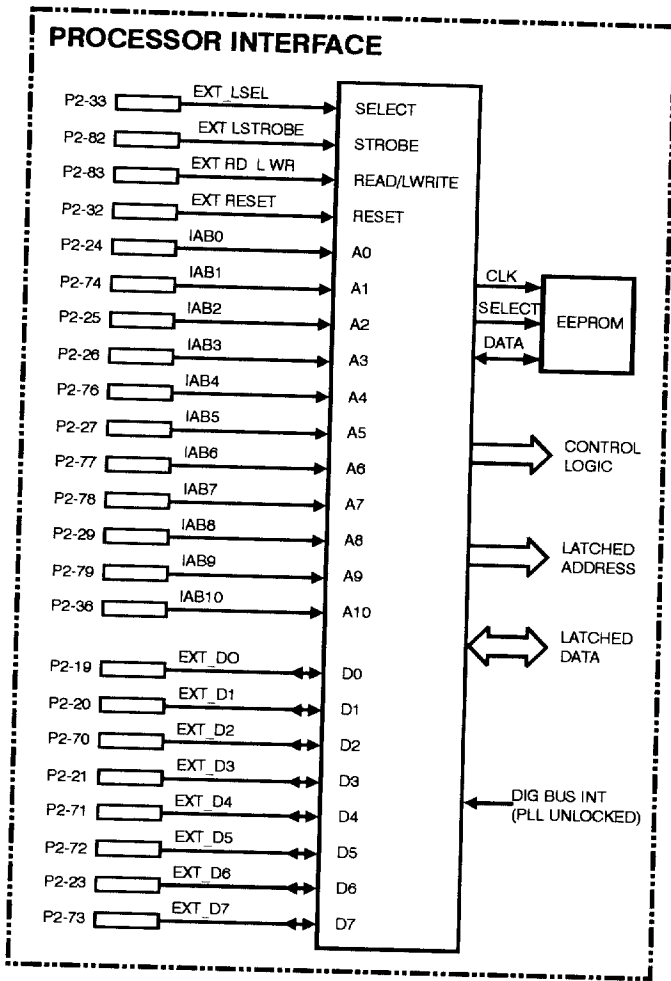

DATA S

CLOCK P2-
DATA P2-
SYNC P2-10
PATTERN TRIGGER P1-

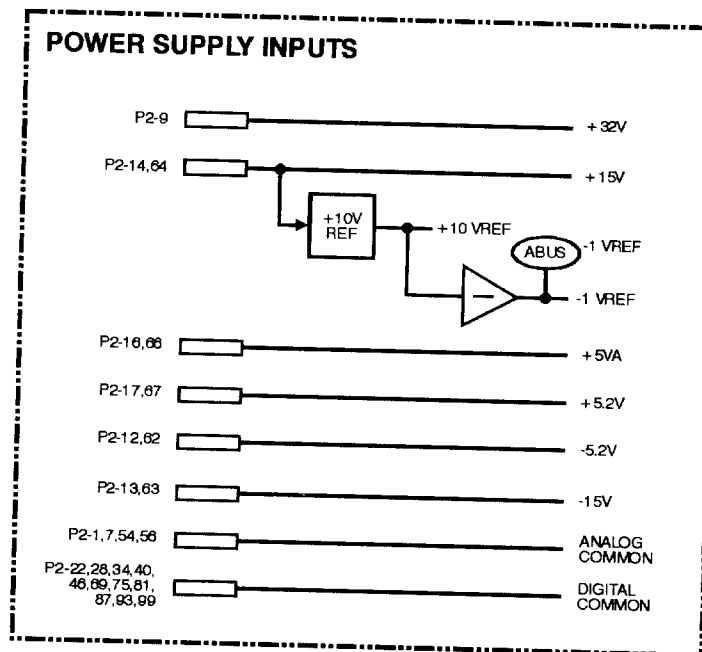

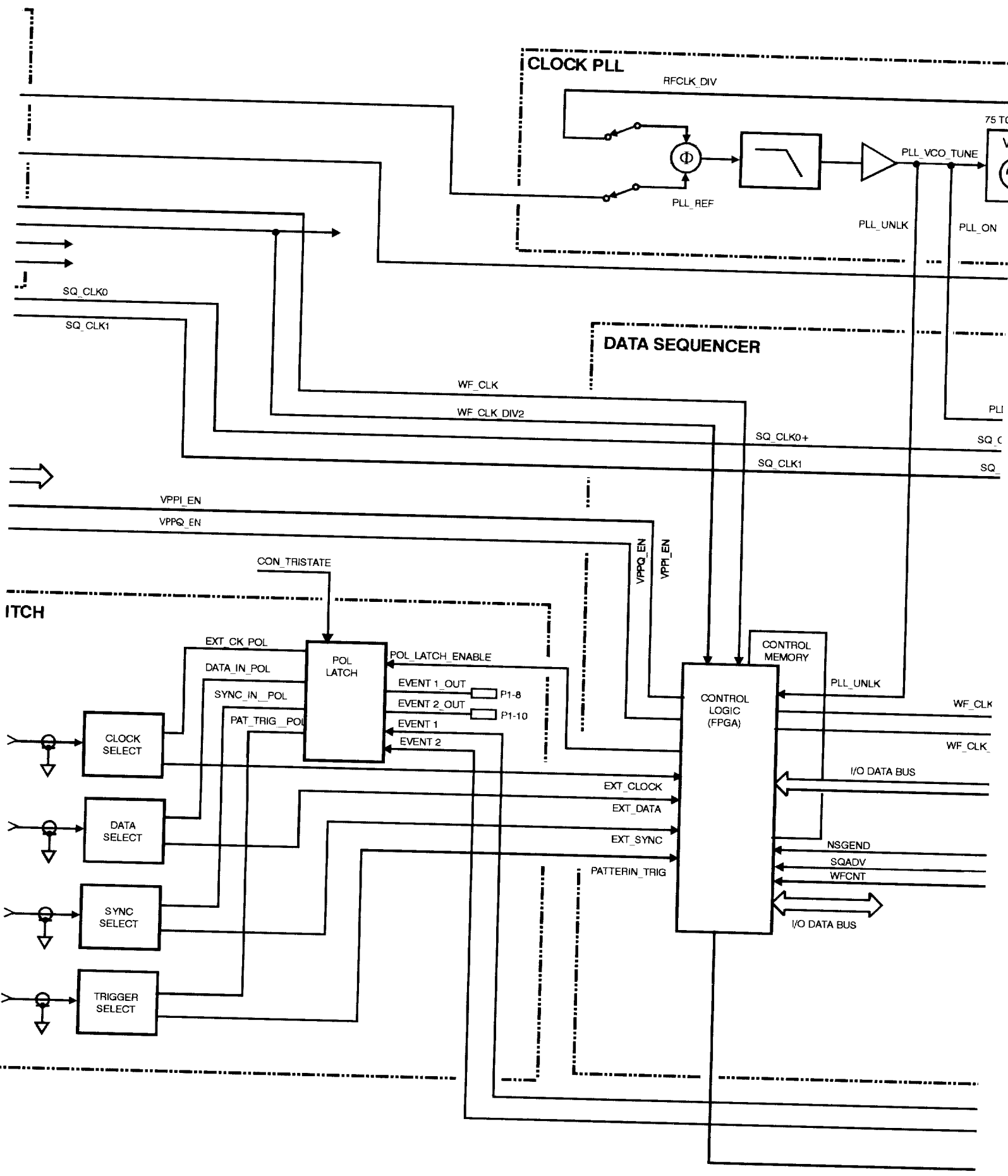

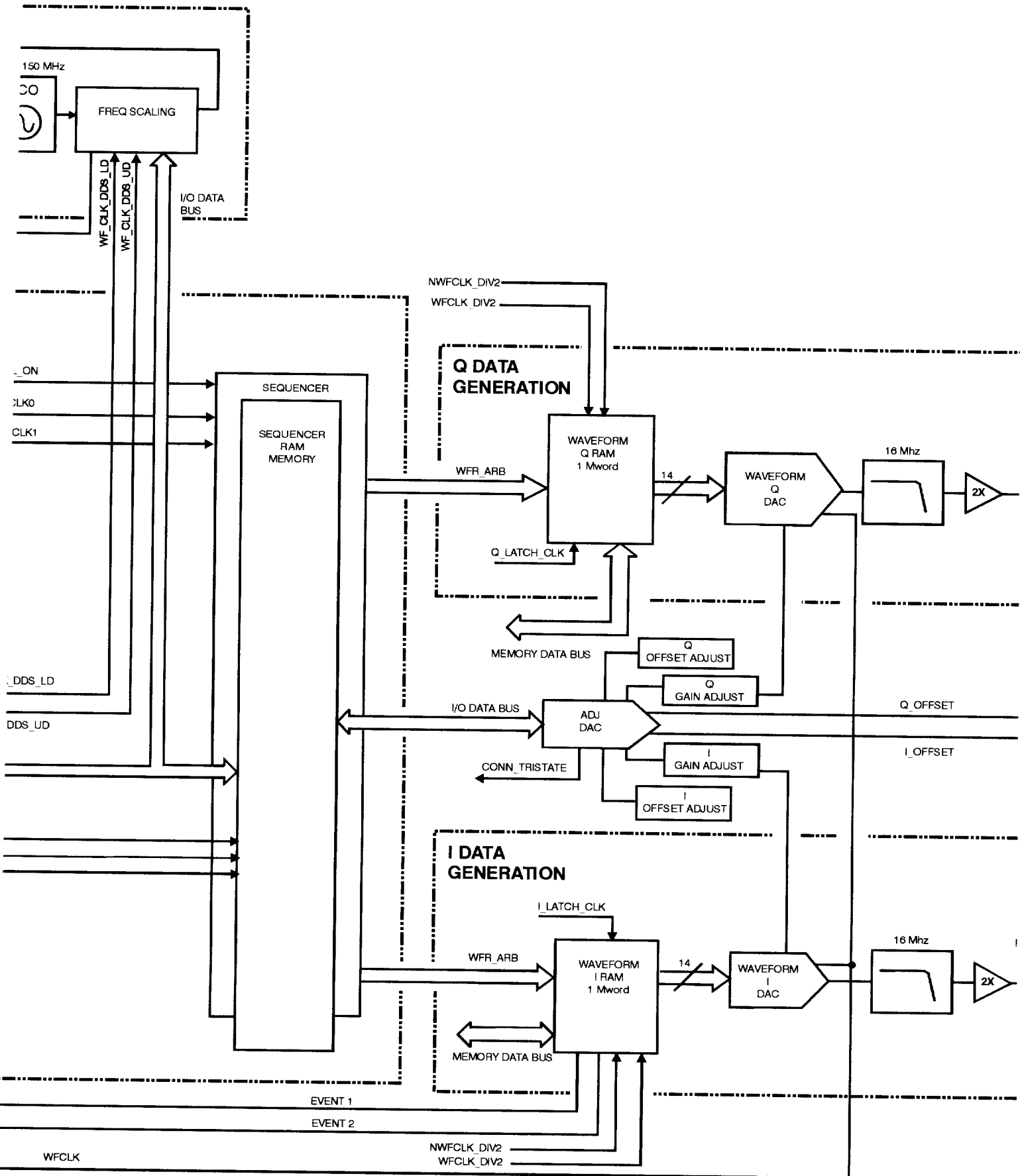

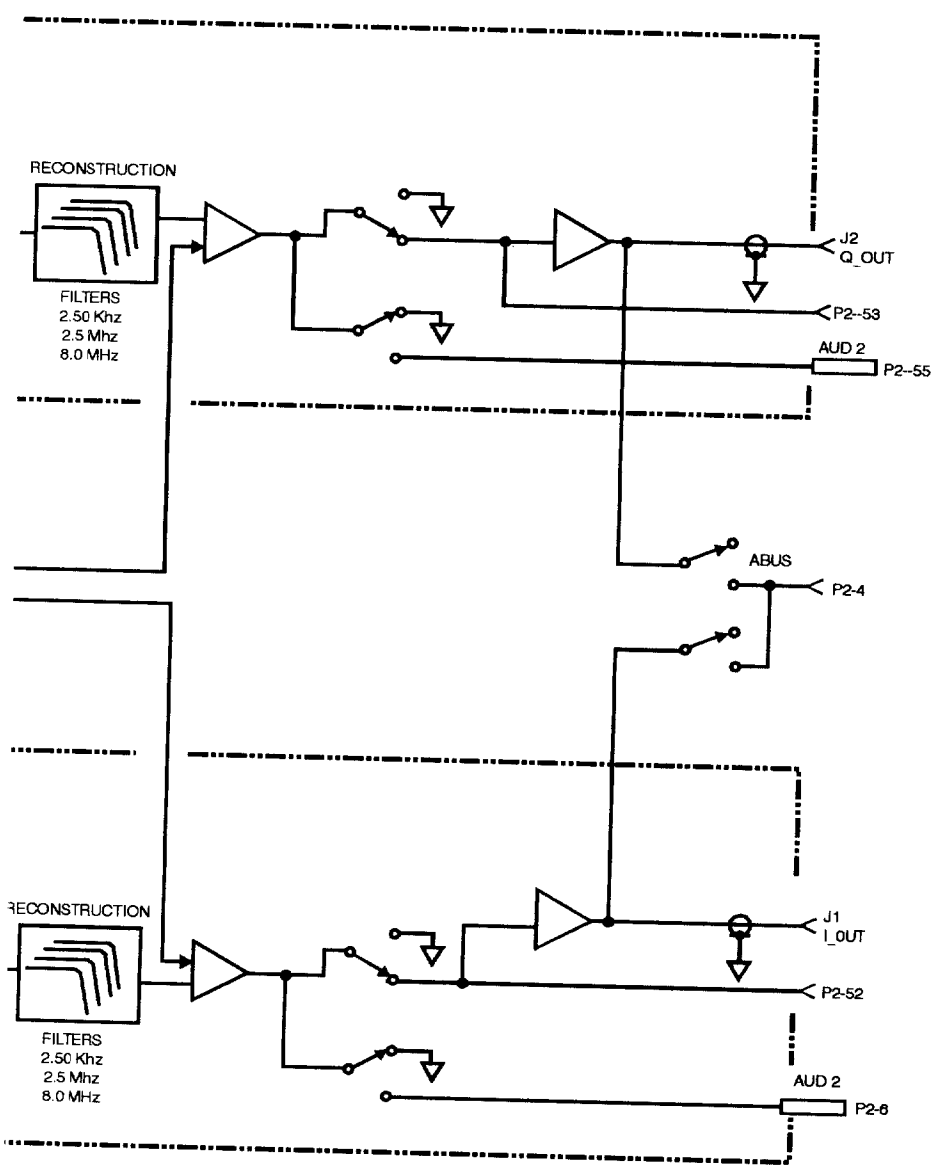

ARBITRARY WAVEFORM GENERATOR BLOCK DIAGRAM (OPT UND)

A7 BASEBAND GENERATOR BLOCK DIAGRAM (OPTIONS UN3 & UN4)

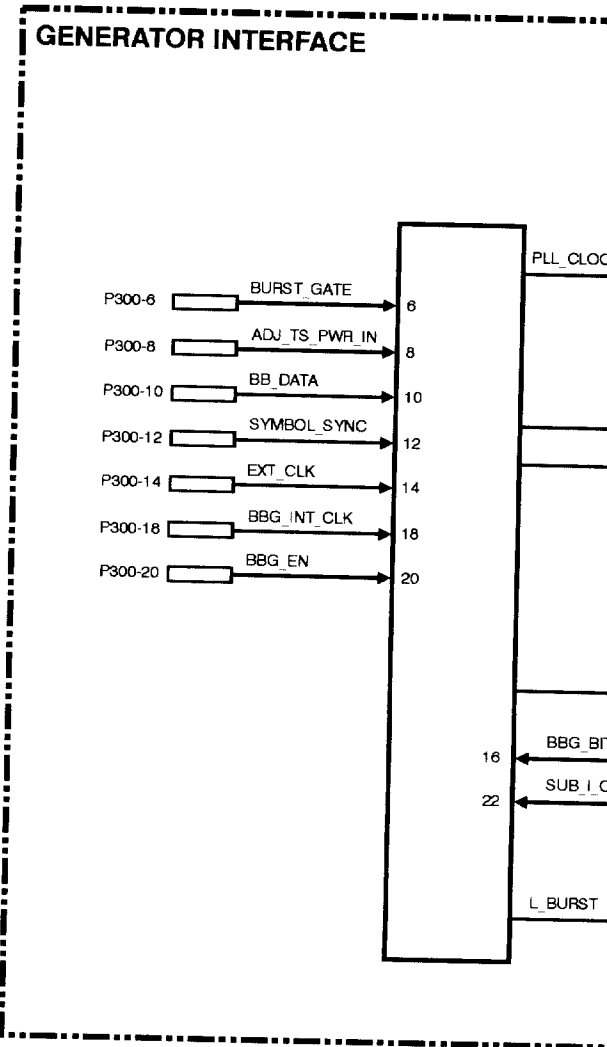
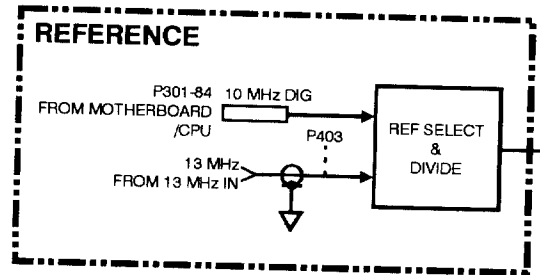

MASTER CLOCK PLL

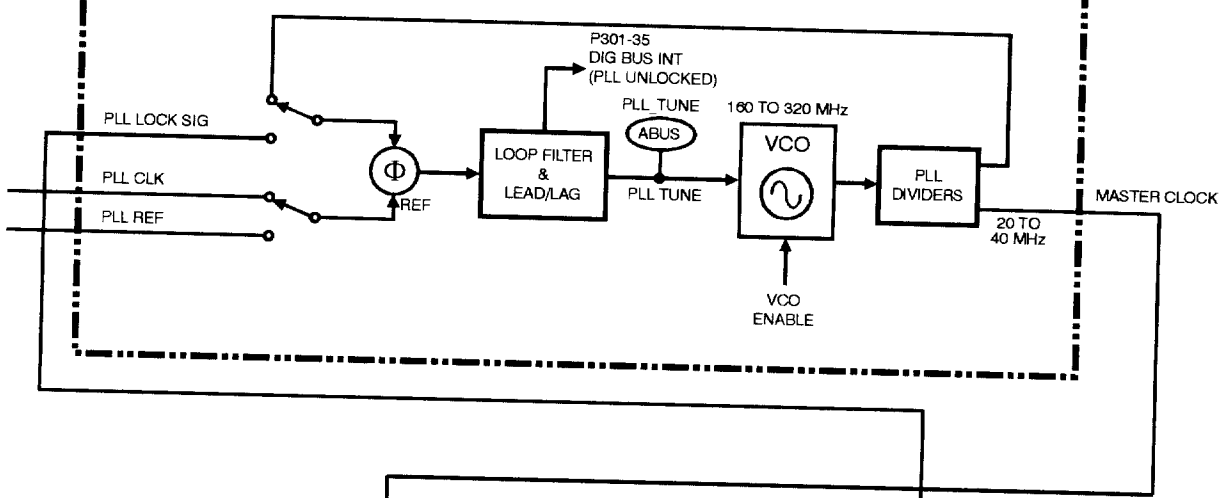

DATA GENERATION CONTROL

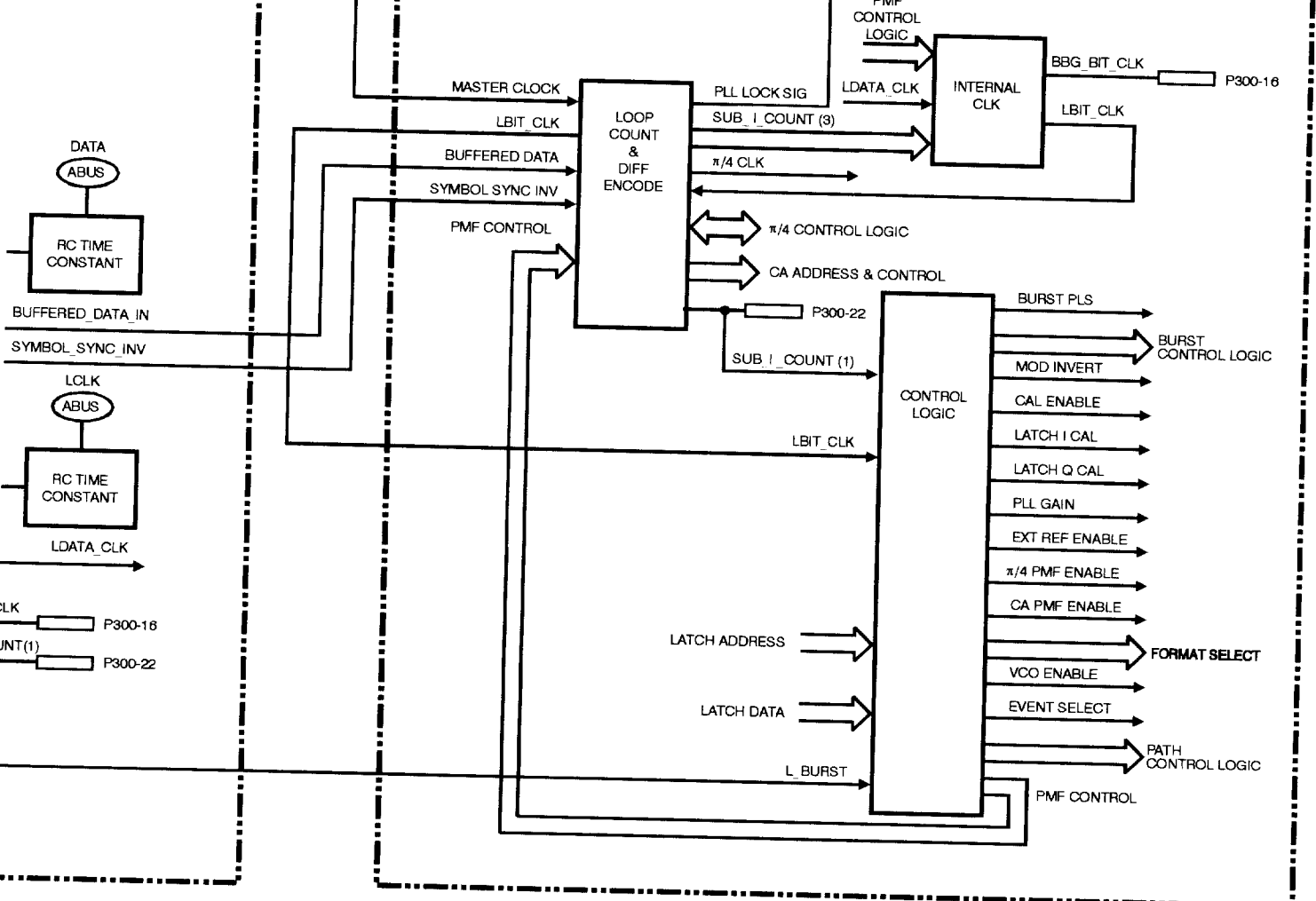

CLK P300-16
 JNT(1) P300-22

DATA GENERATION

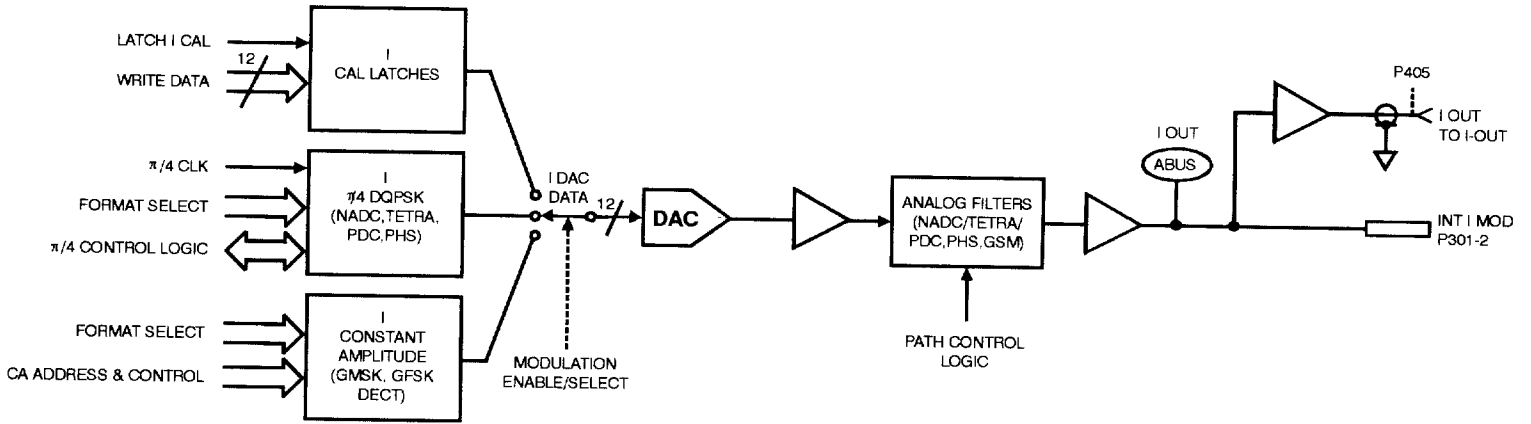

Q DATA GENERATION

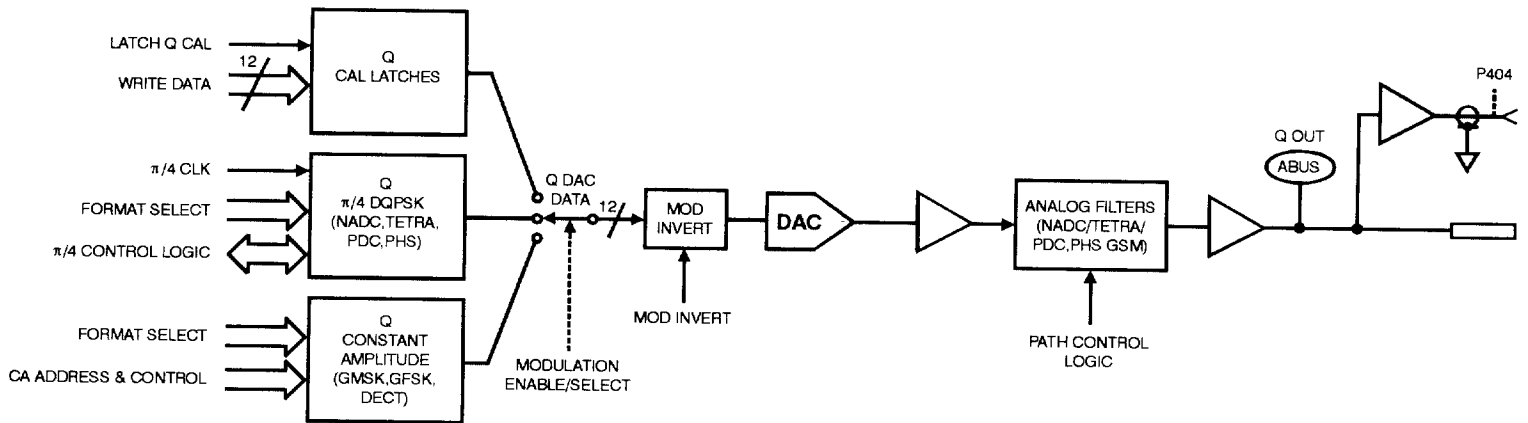

BURST MOD

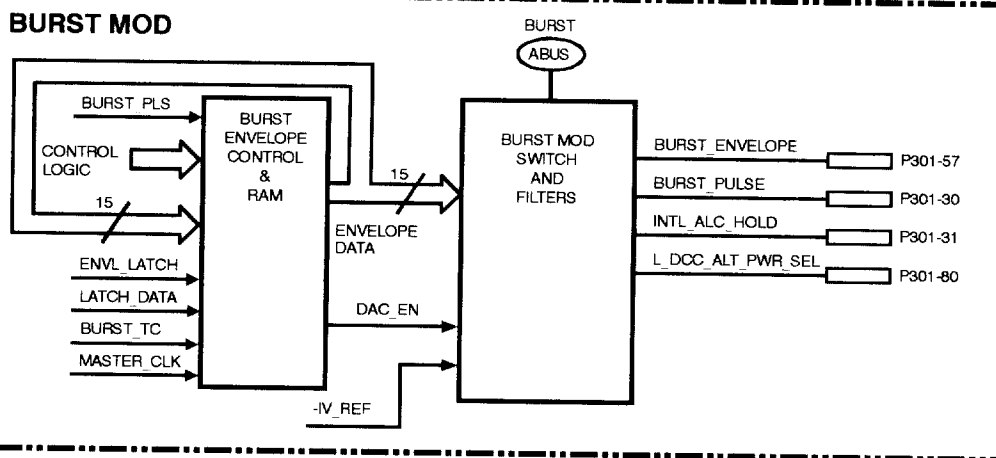

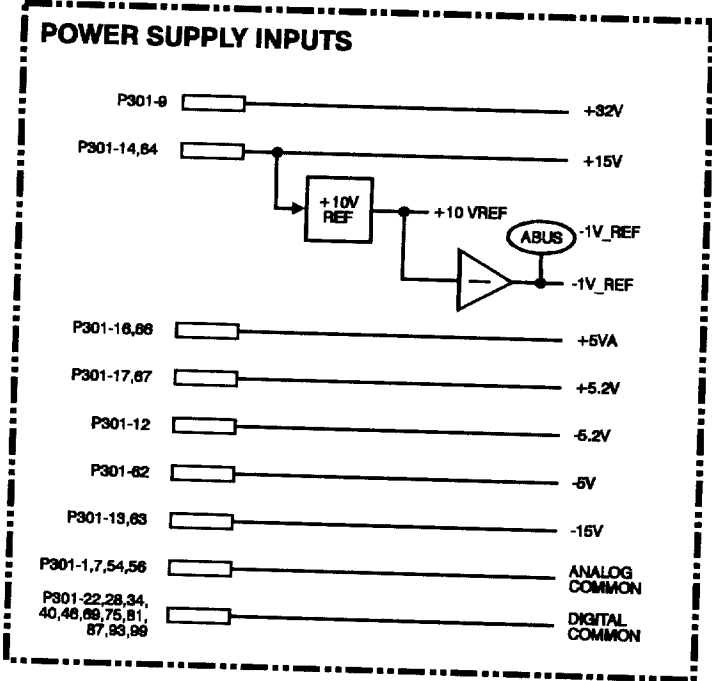
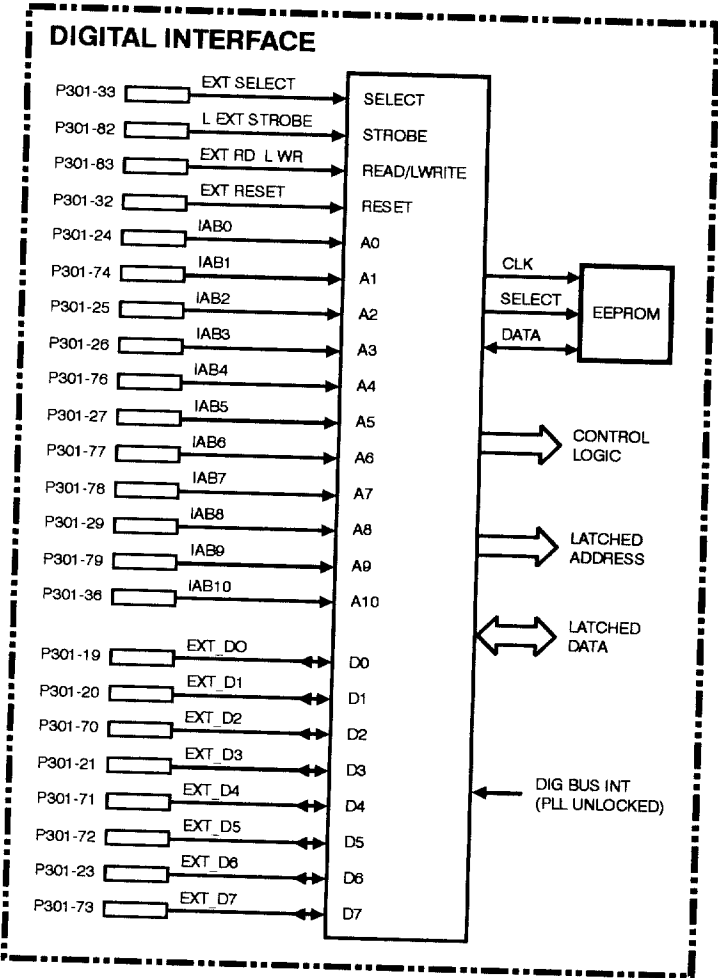
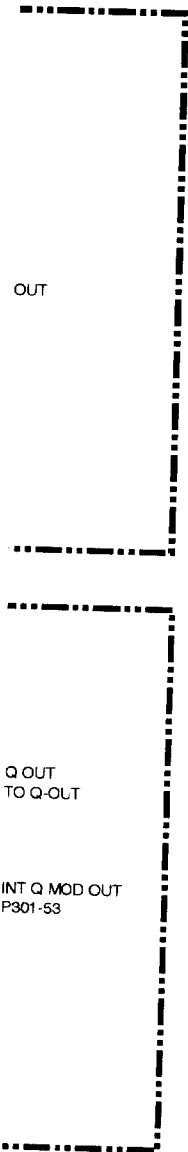

AND GENERATOR BLOCK DIAGRAM (OPTIONS UN3 & UN4)

A9 OUTPUT BLOCK DIAGRAM (ESG-A SERIES)

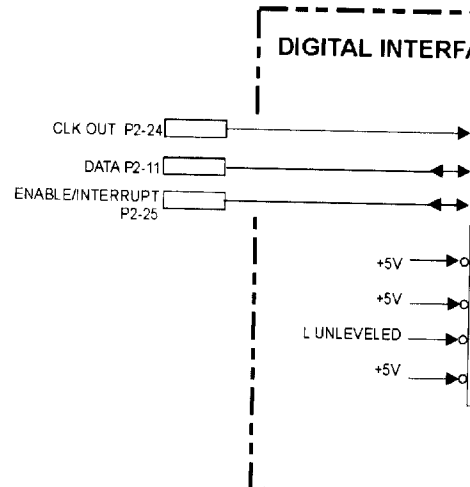
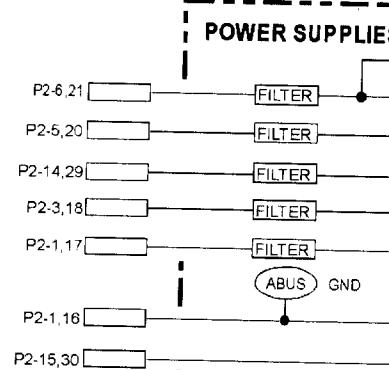
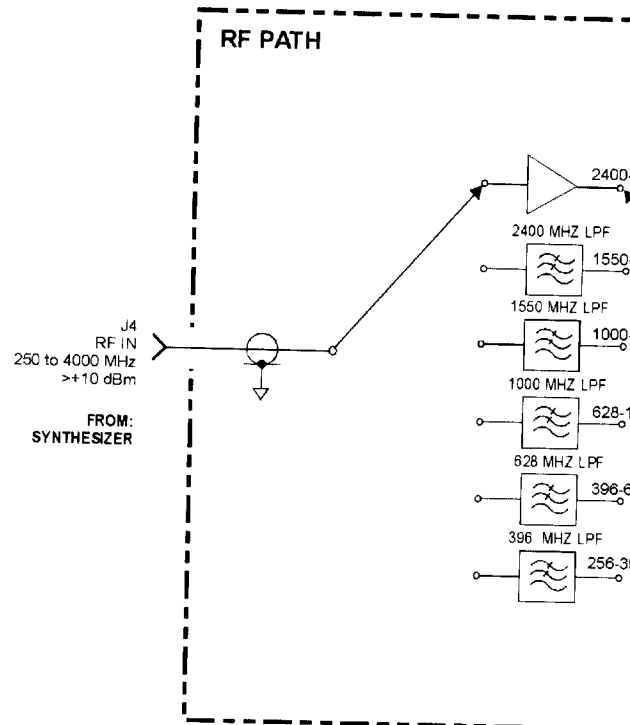

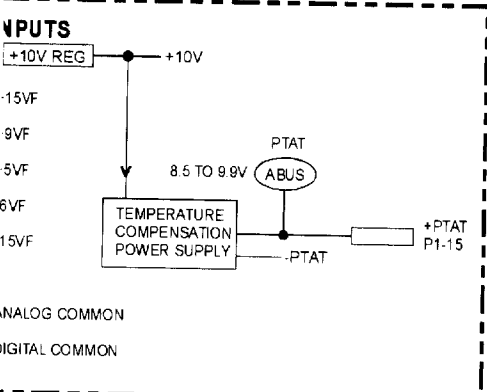
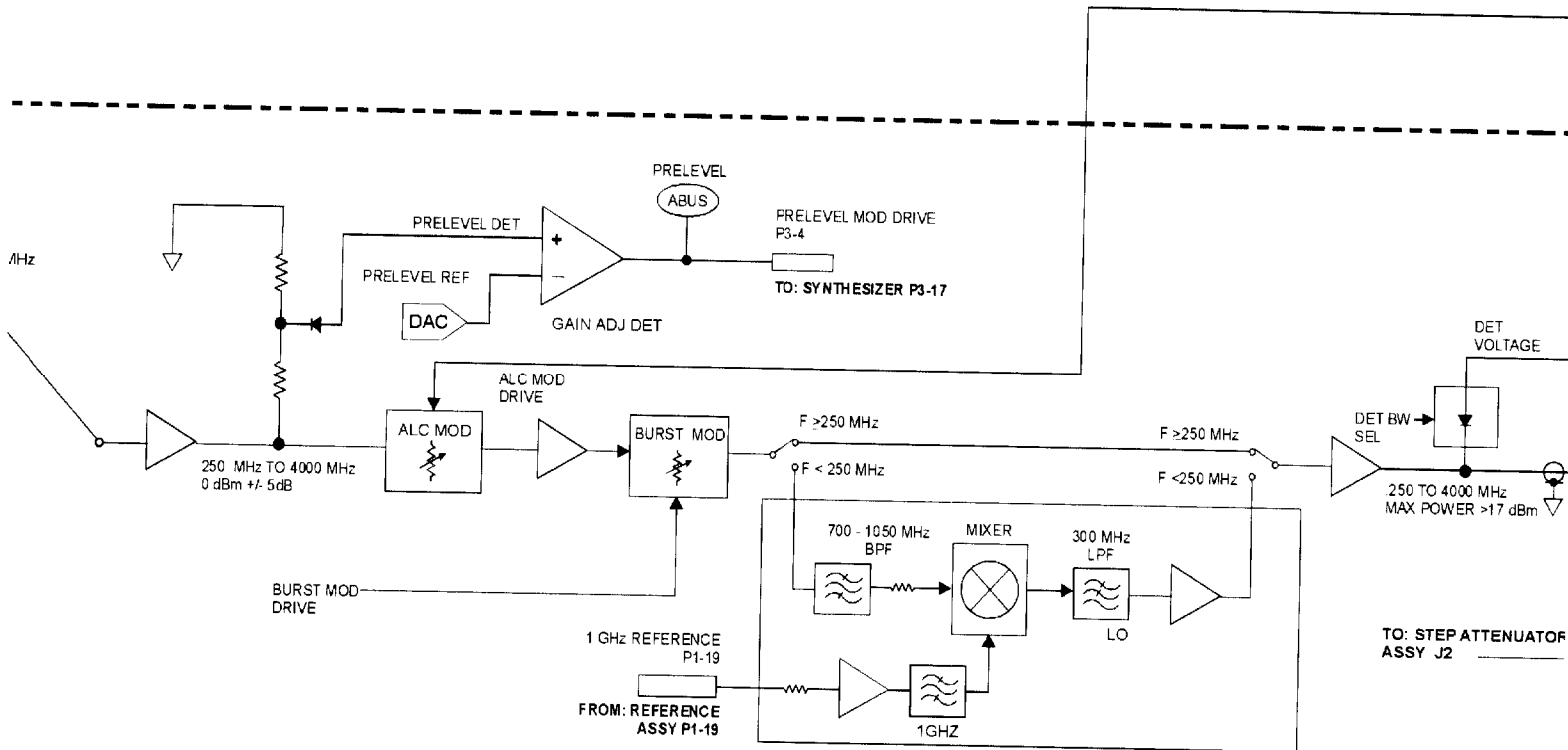

LIN_AM_MOD P1-2
 FROM: REFERENCE ASSY P3-17

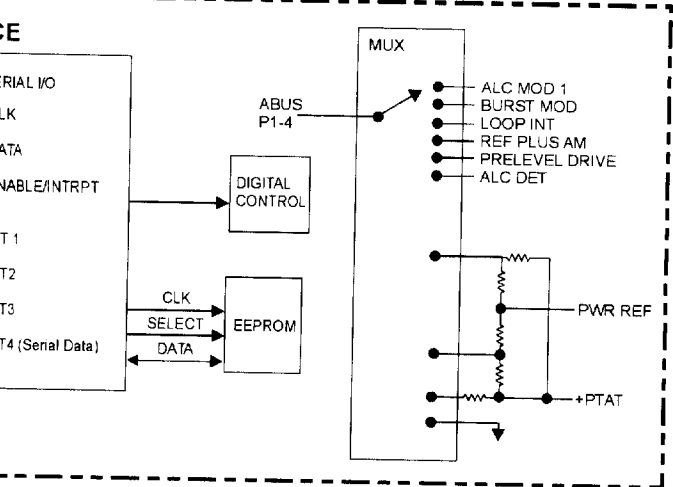

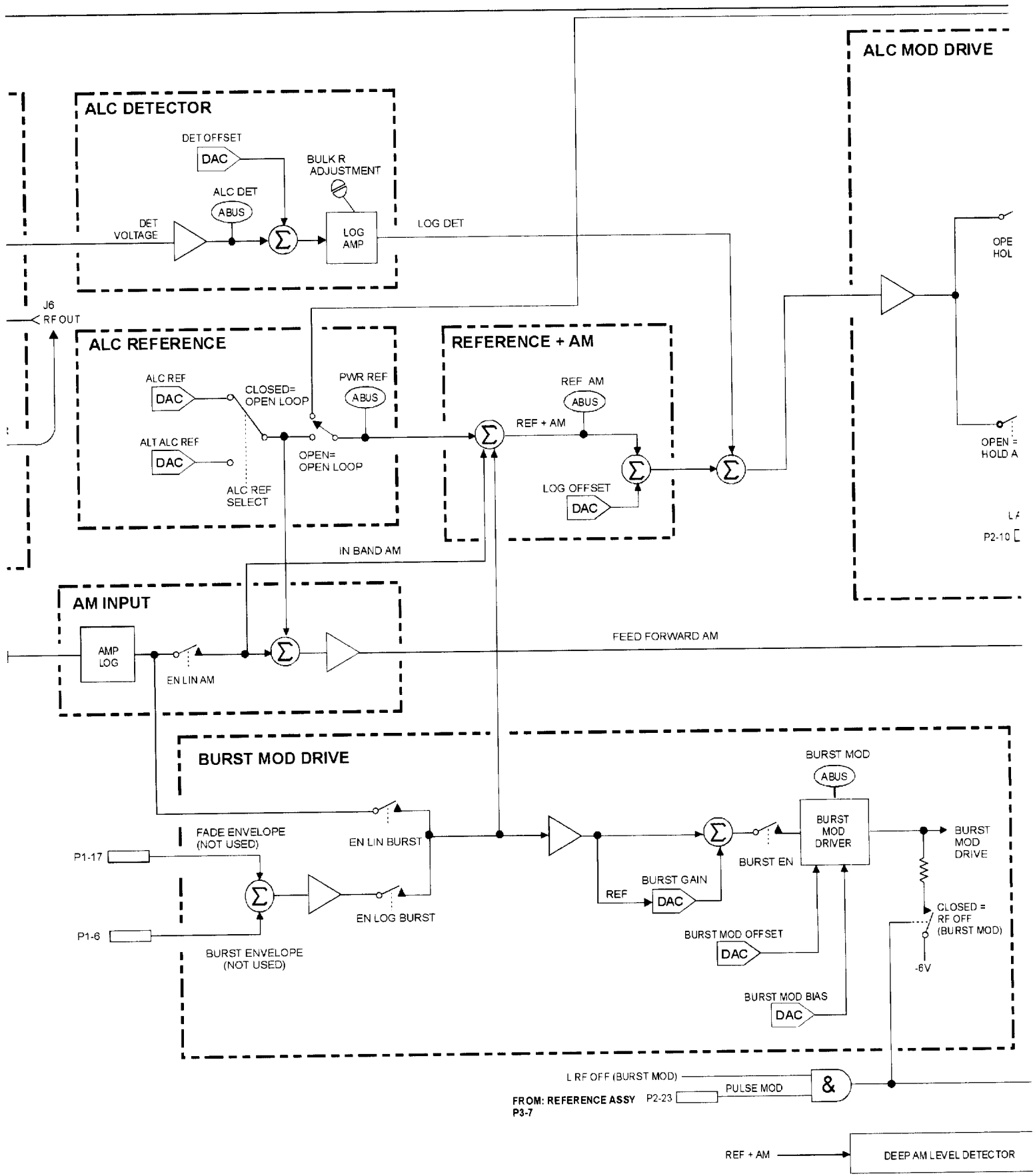

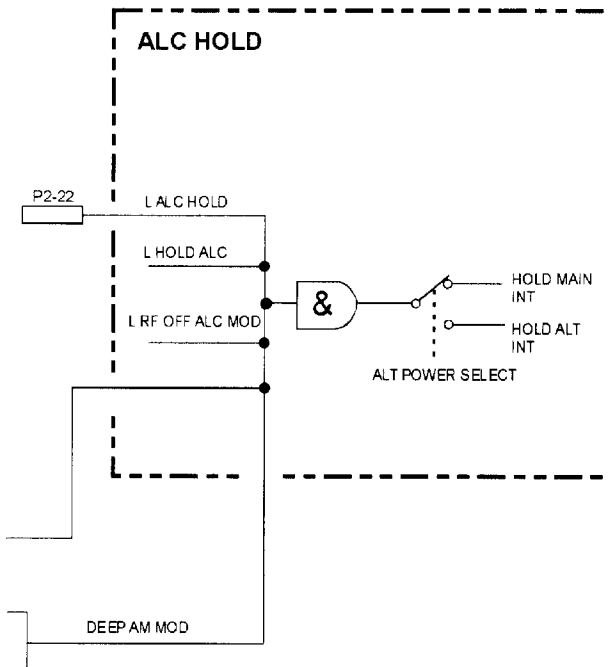
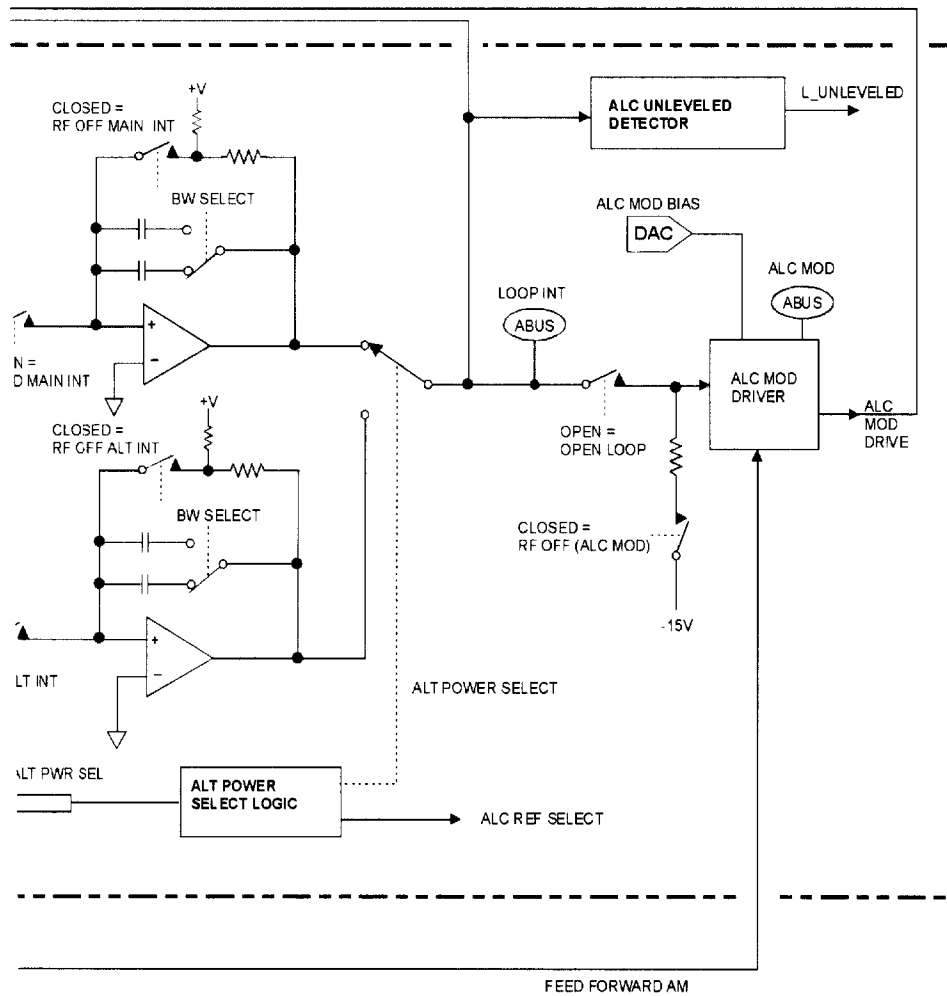

A9 OUTPUT BLOCK DIAGRAM (ESG-A SERIES)

A9 OUTPUT BLOCK DIAGRAM (ESG-D, ESG-AP, & ESG-DP SERIES)

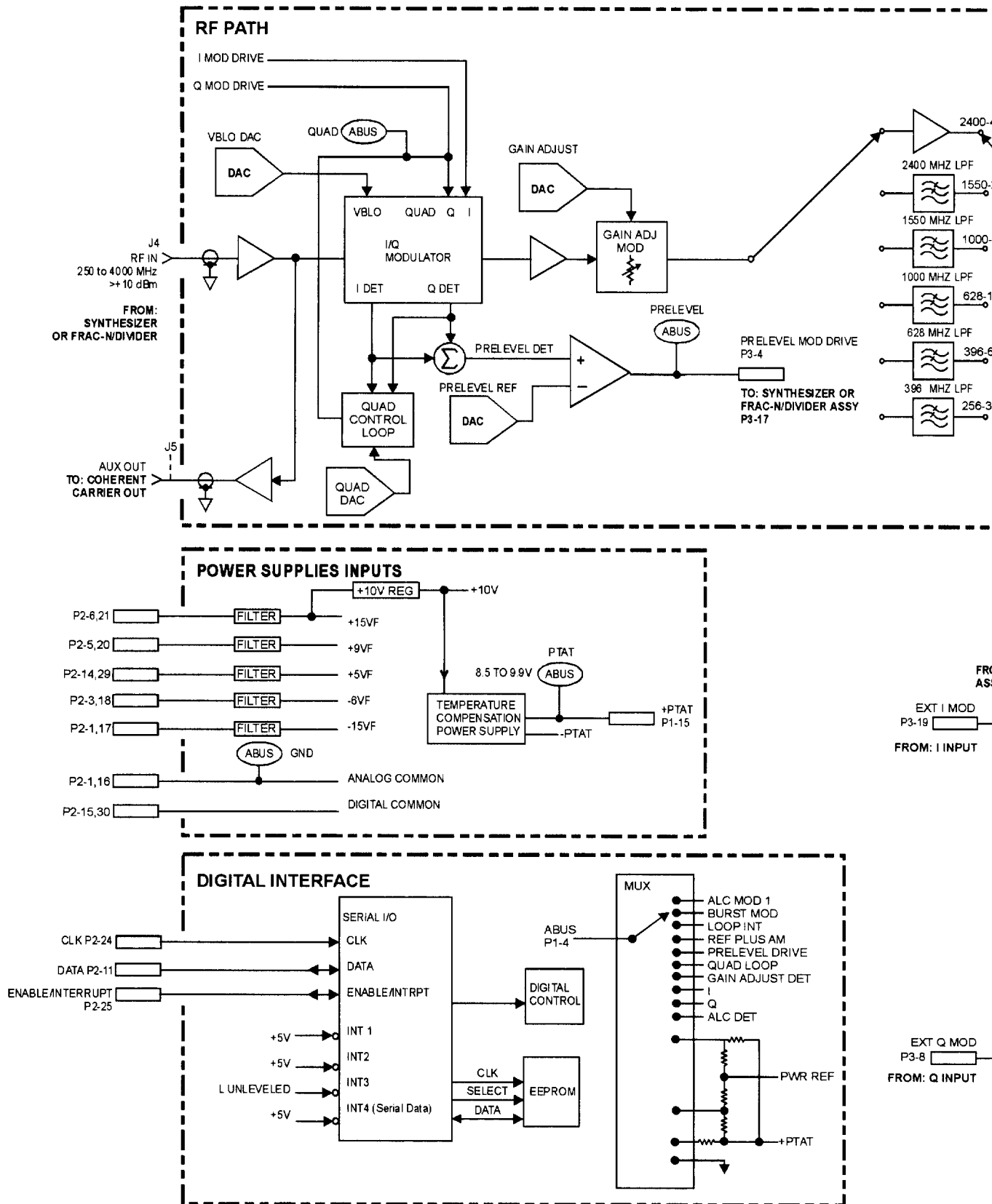

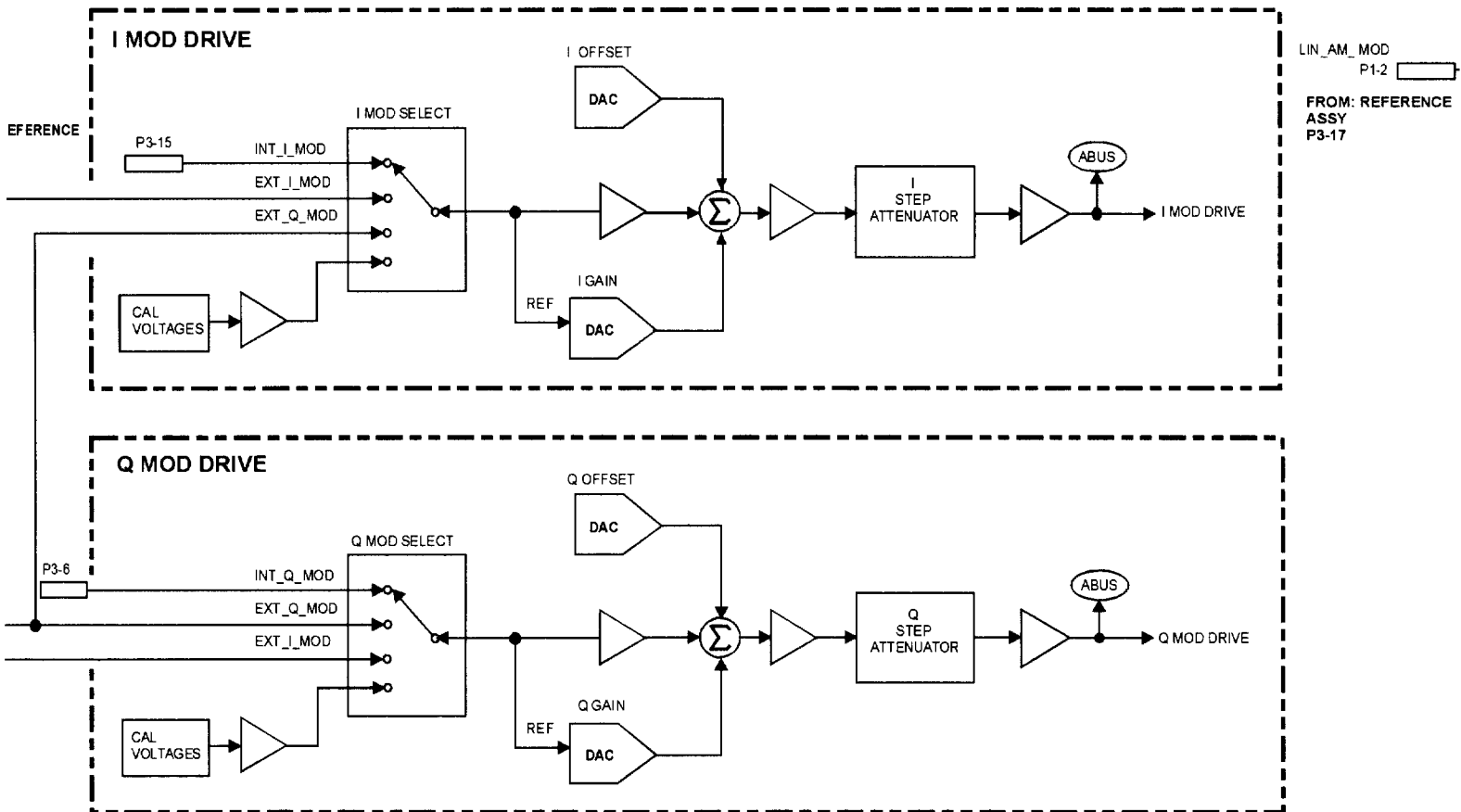
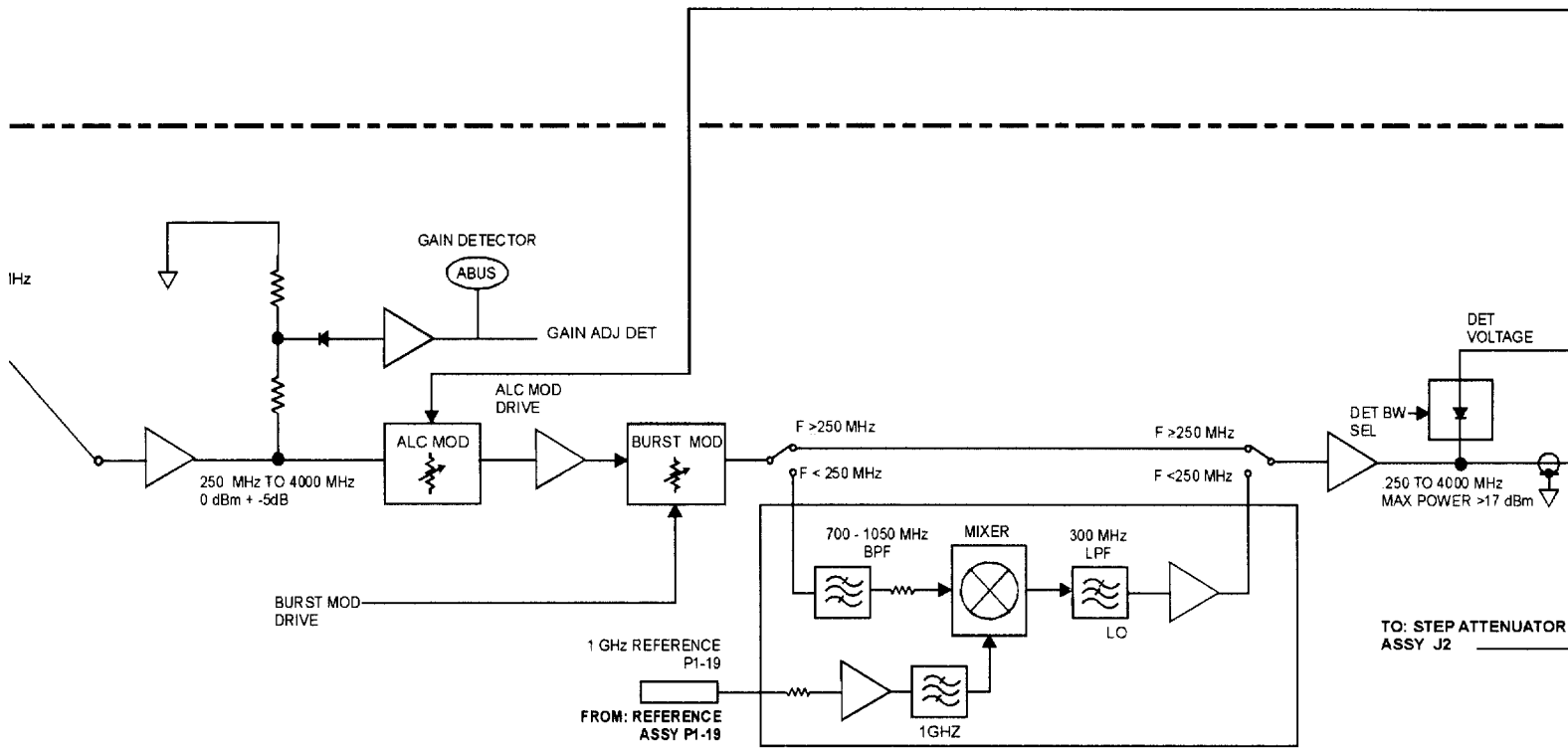

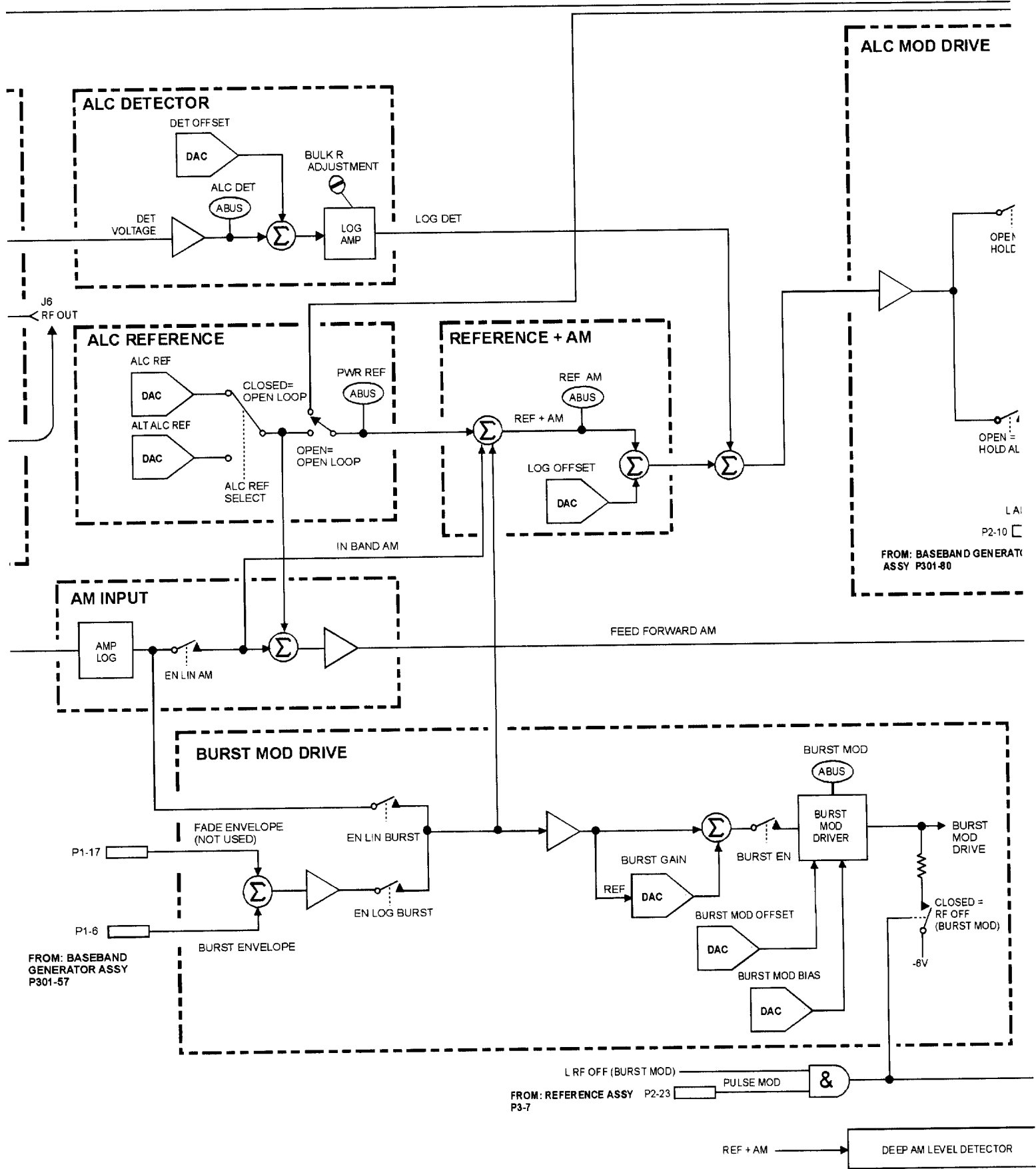

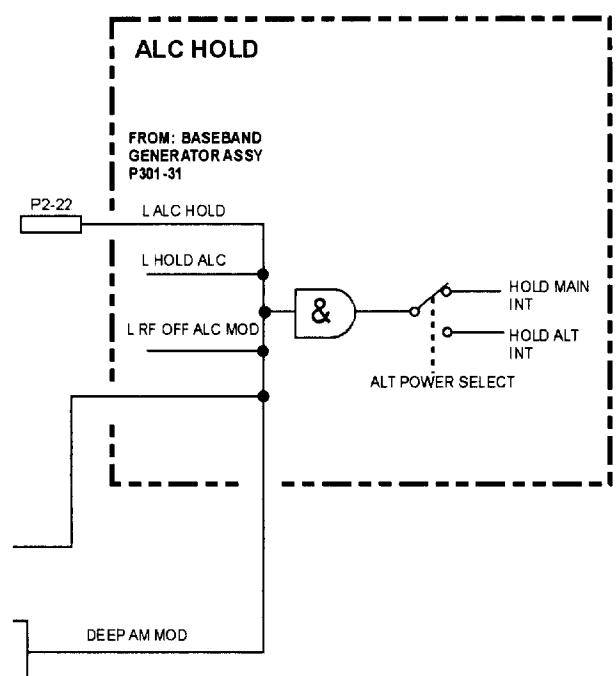
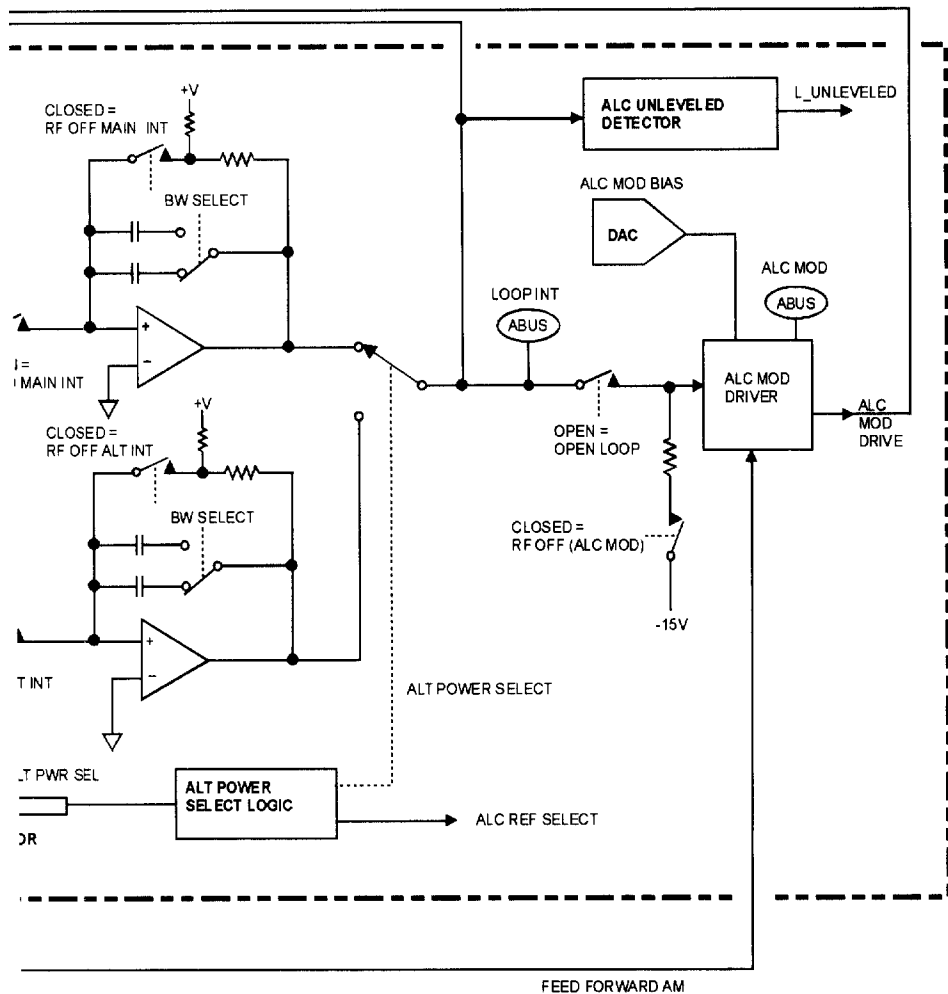

**A9 OUTPUT BLOCK DIAGRAM
(ESG-D, ESG-DP, & ESG-DP SERIES)**

A11 REFERENCE BLOCK DIAGRAM (ESG-A & ESG-D SERIES)

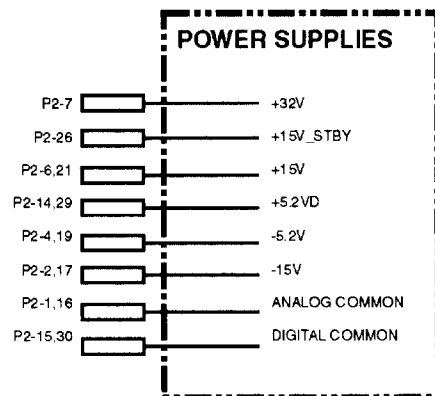
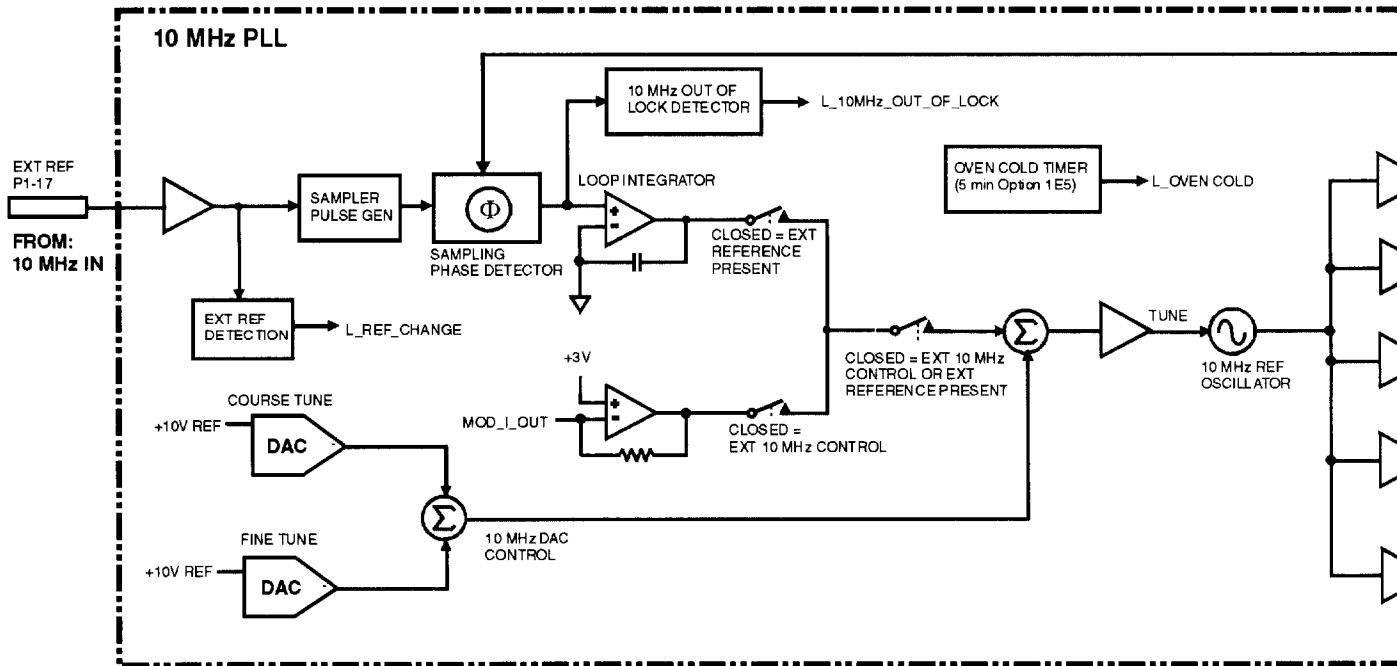

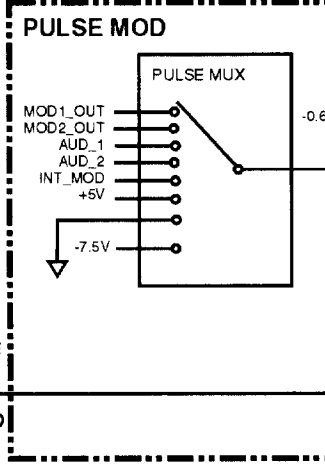
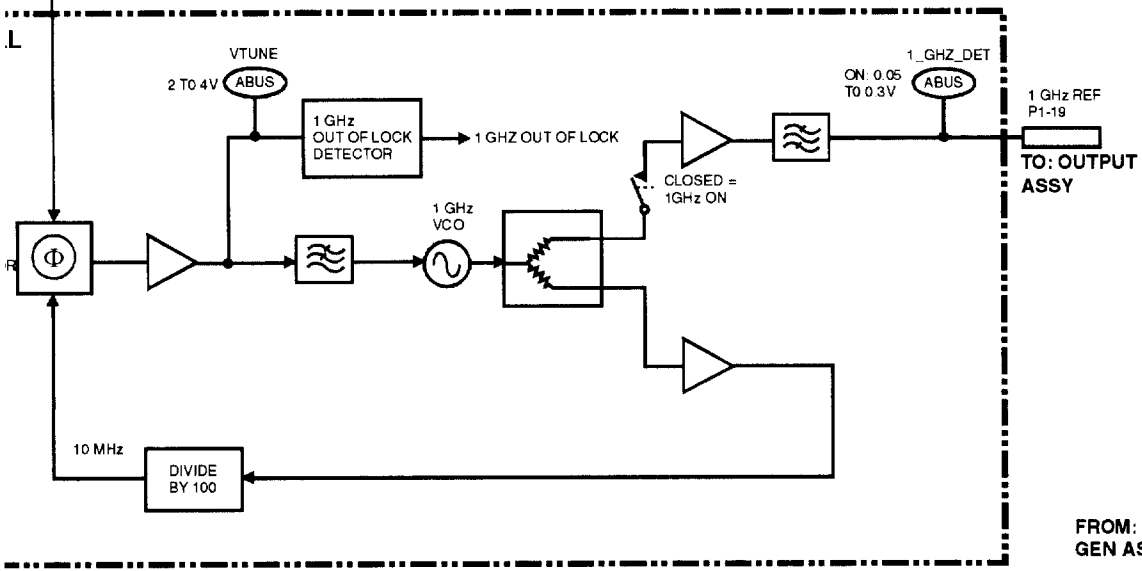
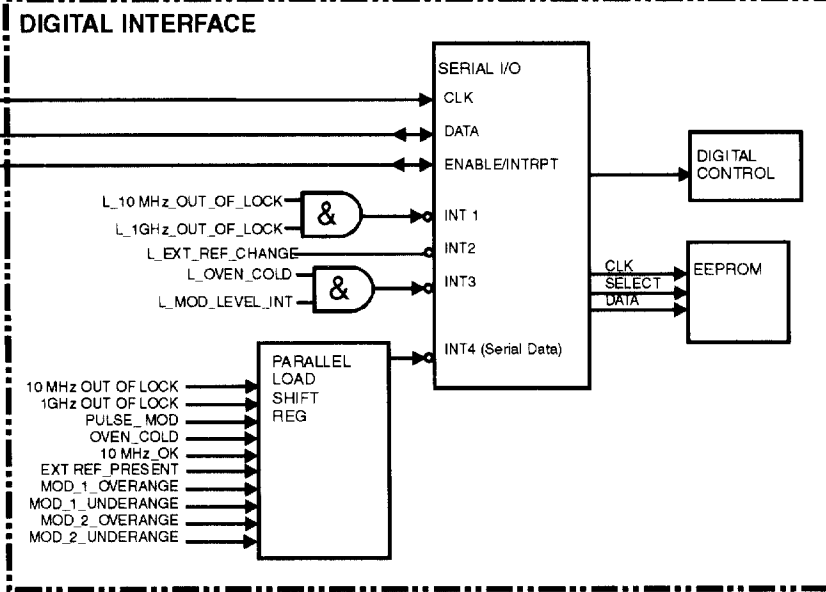
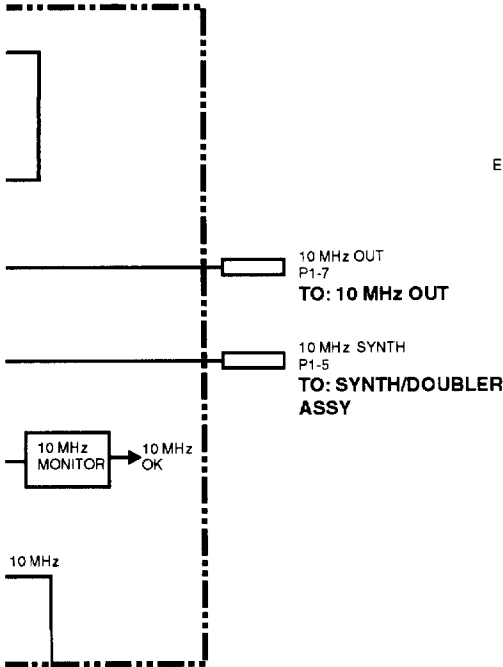

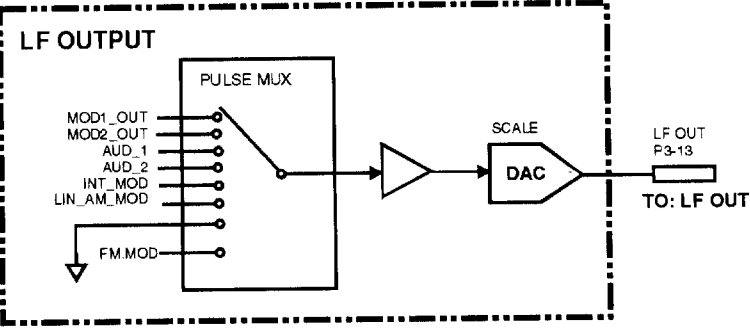
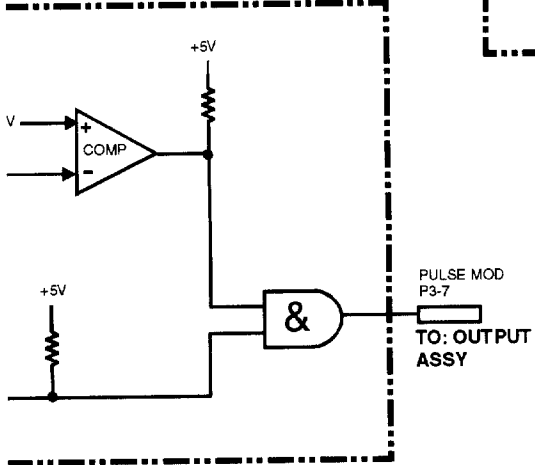
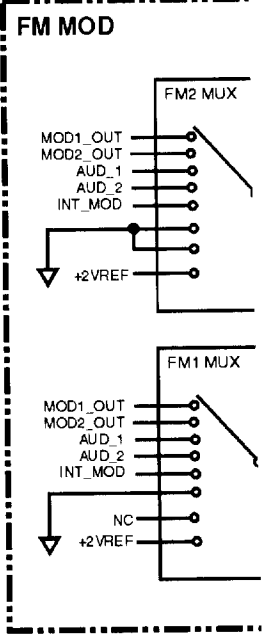
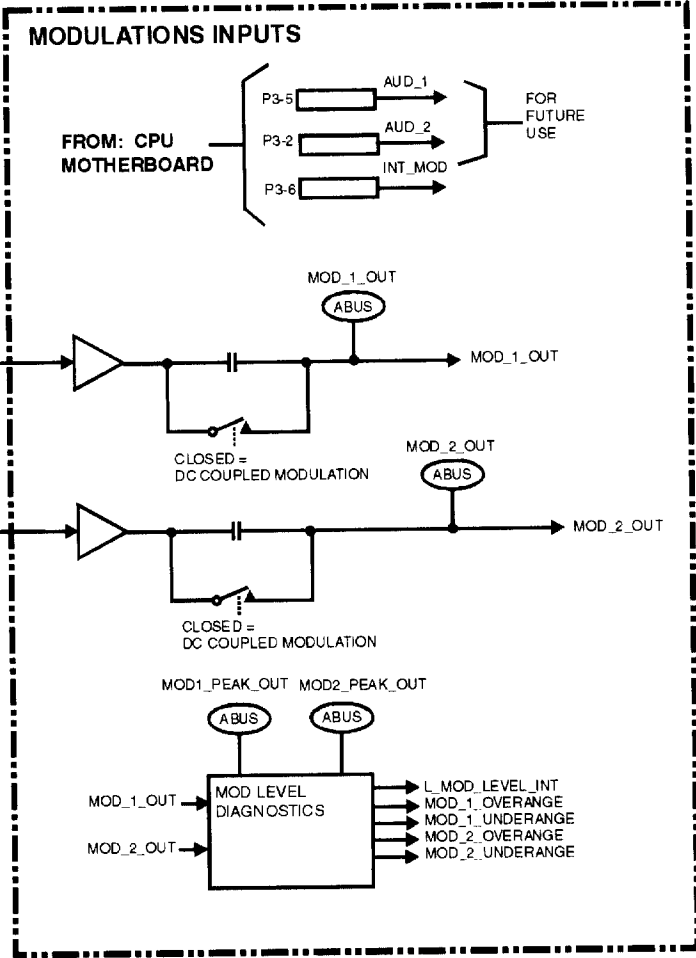

AI

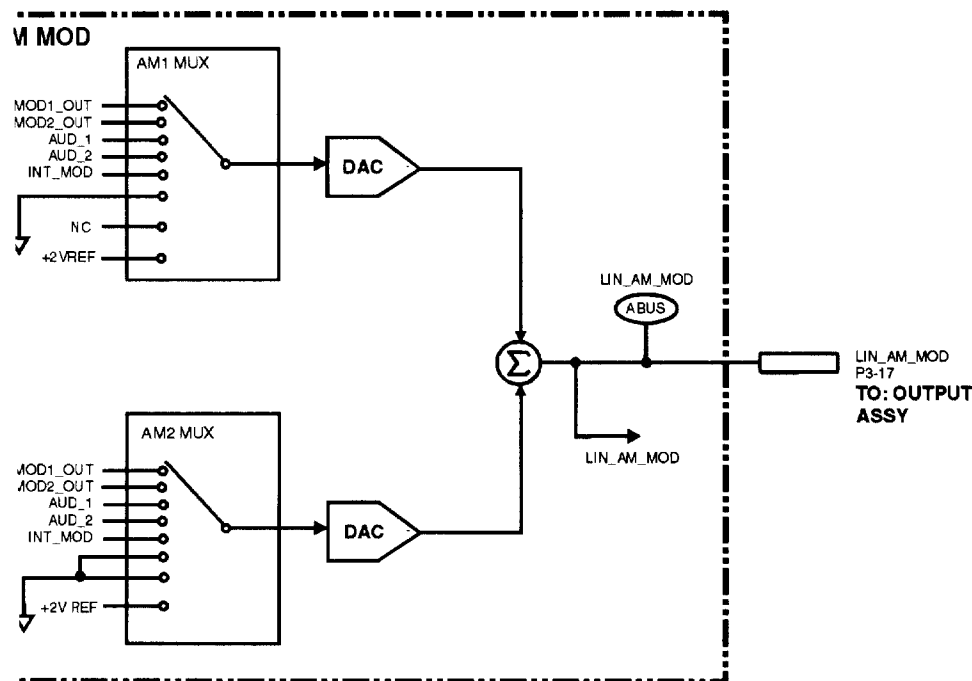
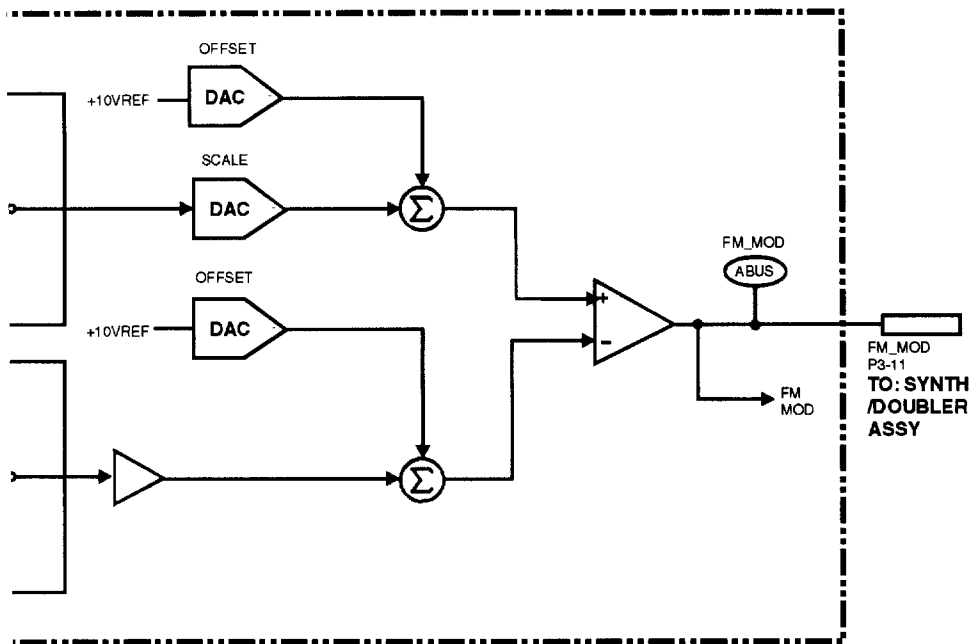

**A11 REFERENCE BLOCK DIAGRAM
(ESG-A & ESG-D)**

A11 REFERENCE BLOCK DIAGRAM (ESG-AP & ESG-DP SERIES)

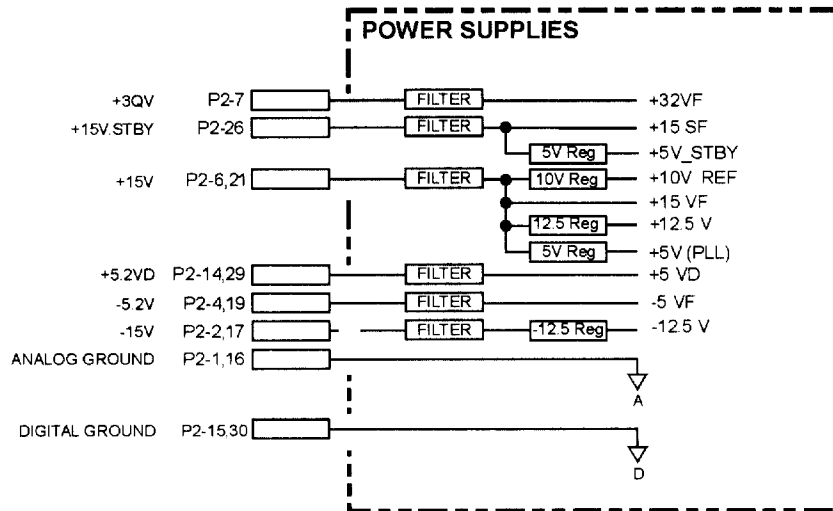
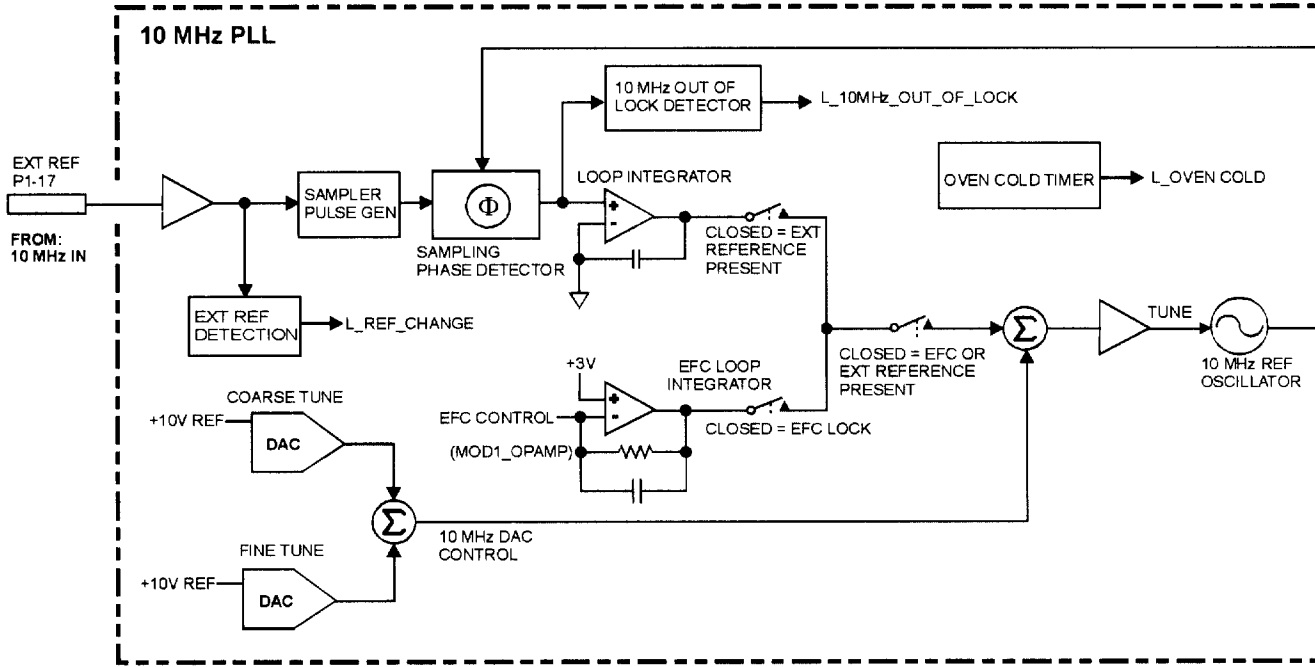

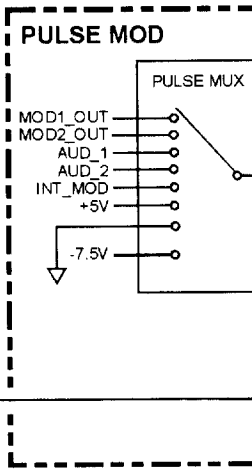
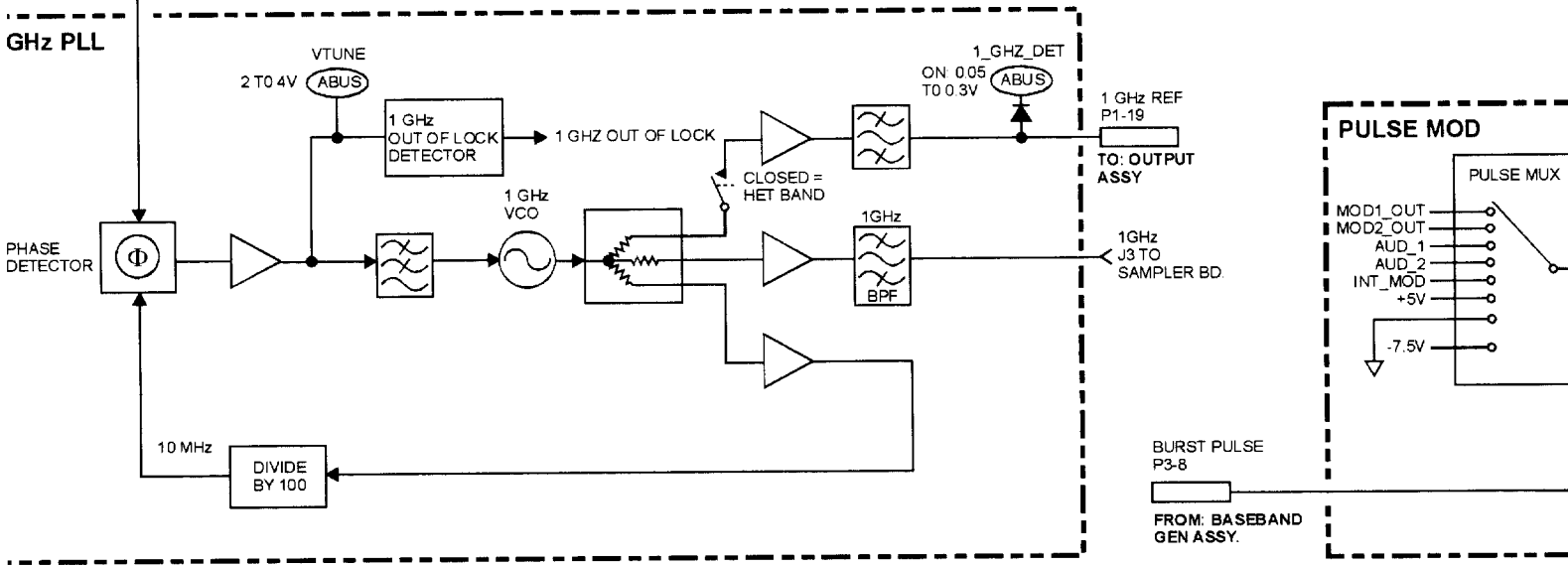
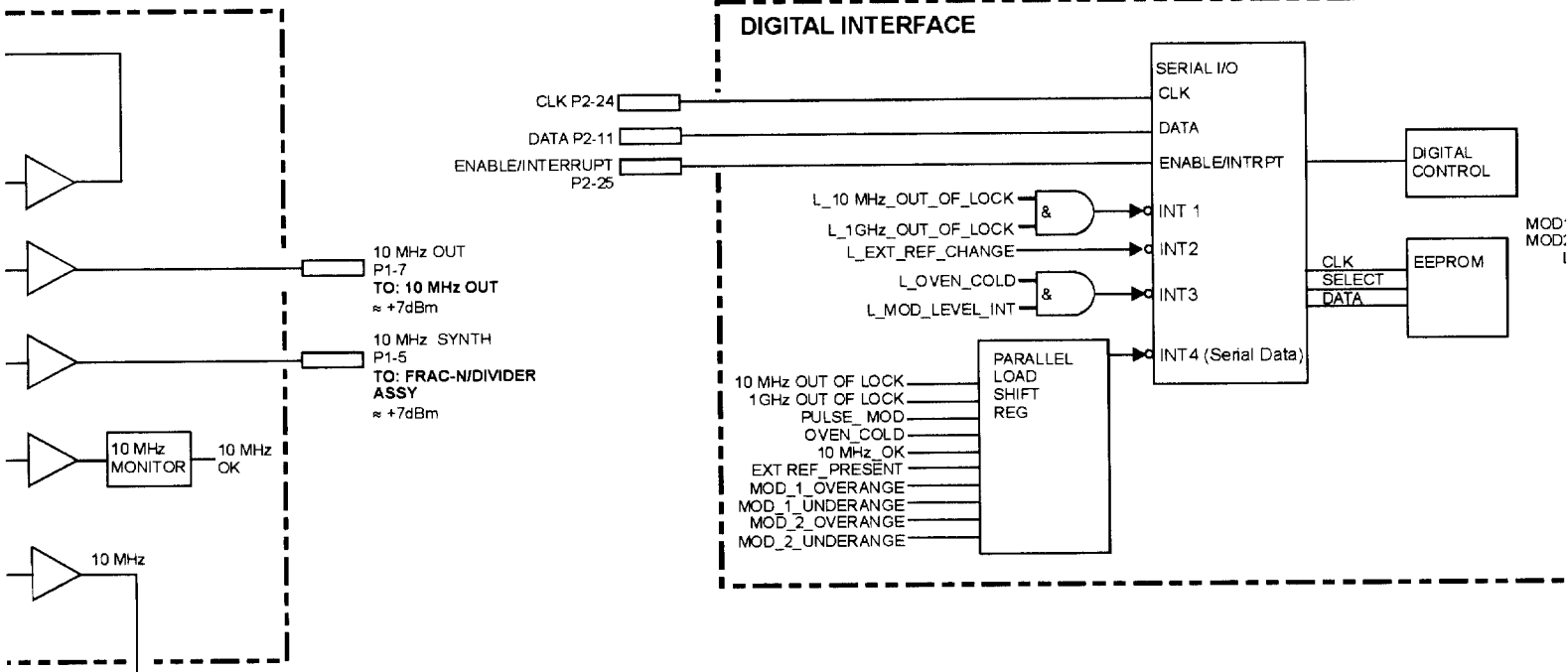

BURST PULSE P3-8
 FROM: BASEBAND GEN ASSY.

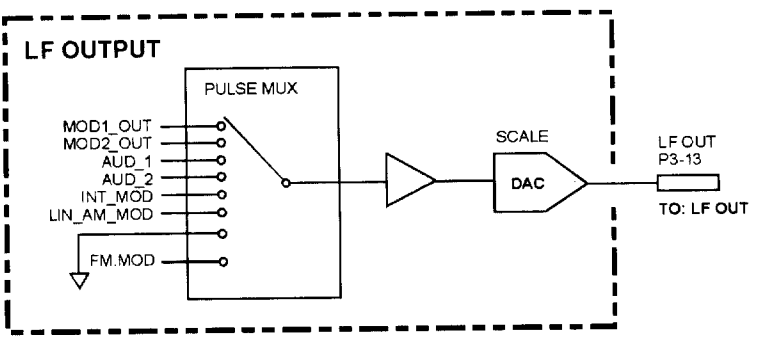
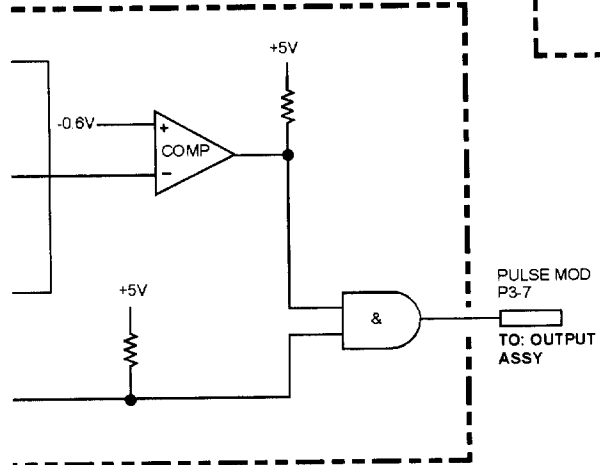
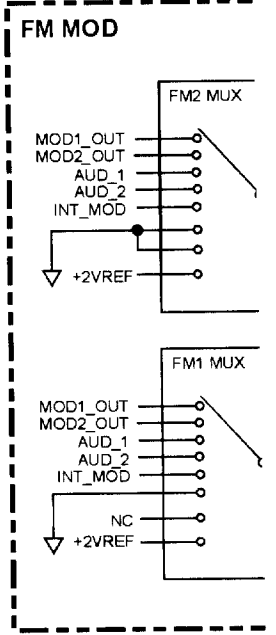
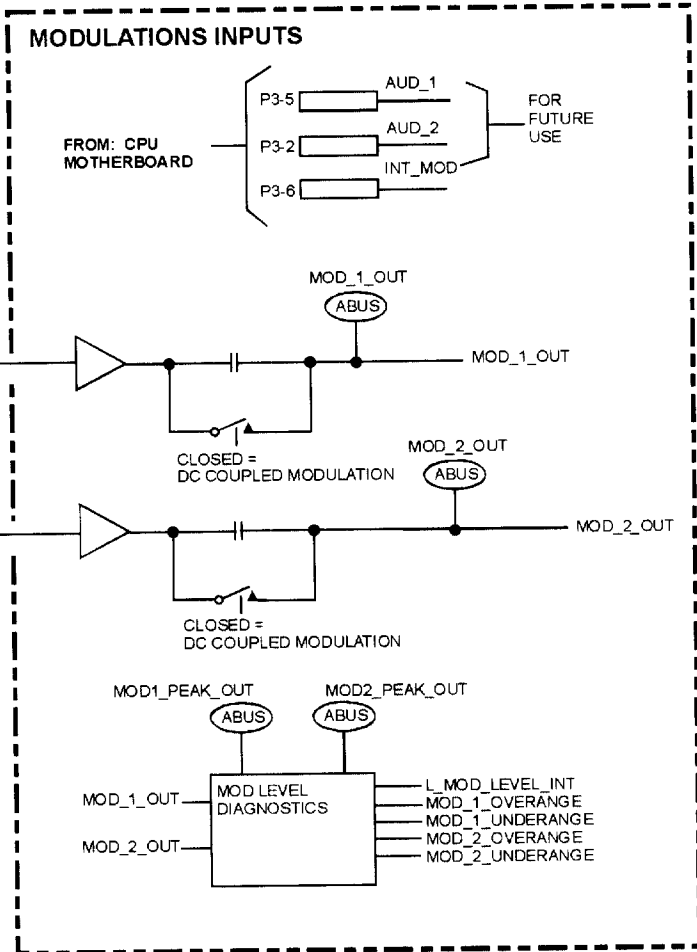
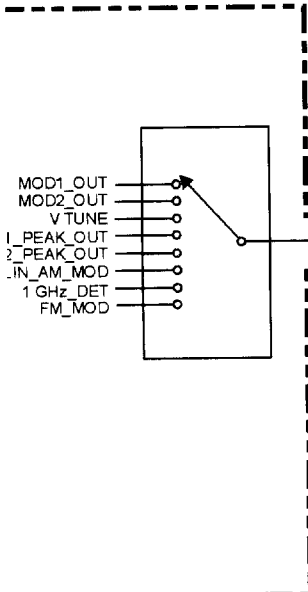

AM

M

M

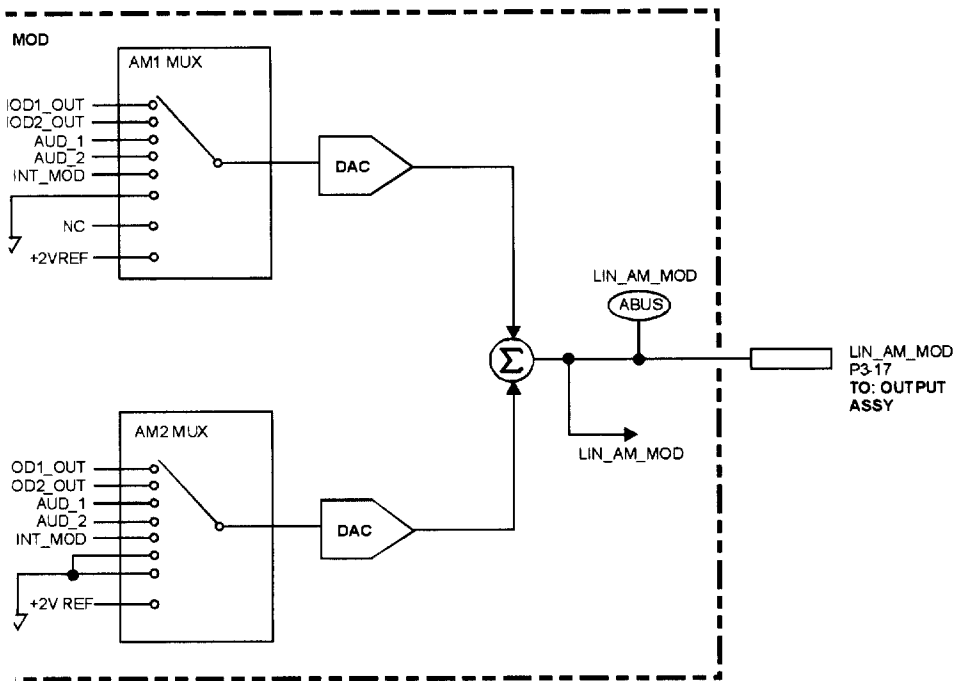
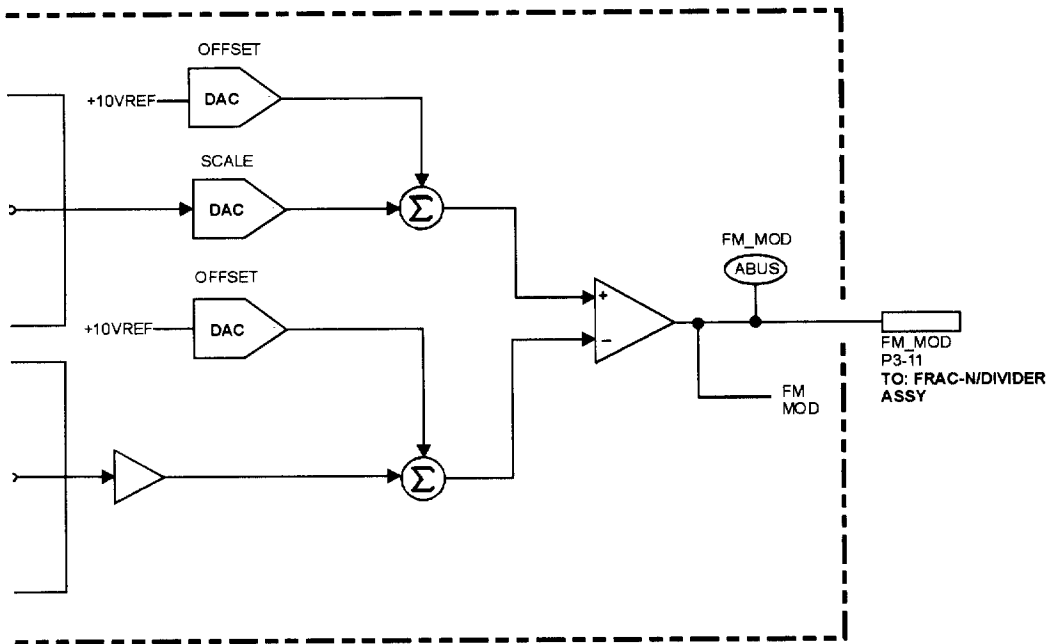

REFERENCE BLOCK DIAGRAM (ESG-AP & ESG-DP SERIES)

A14 CPU/MOTHERBOARD BLOCK DIAGRAM (1 OF 2)

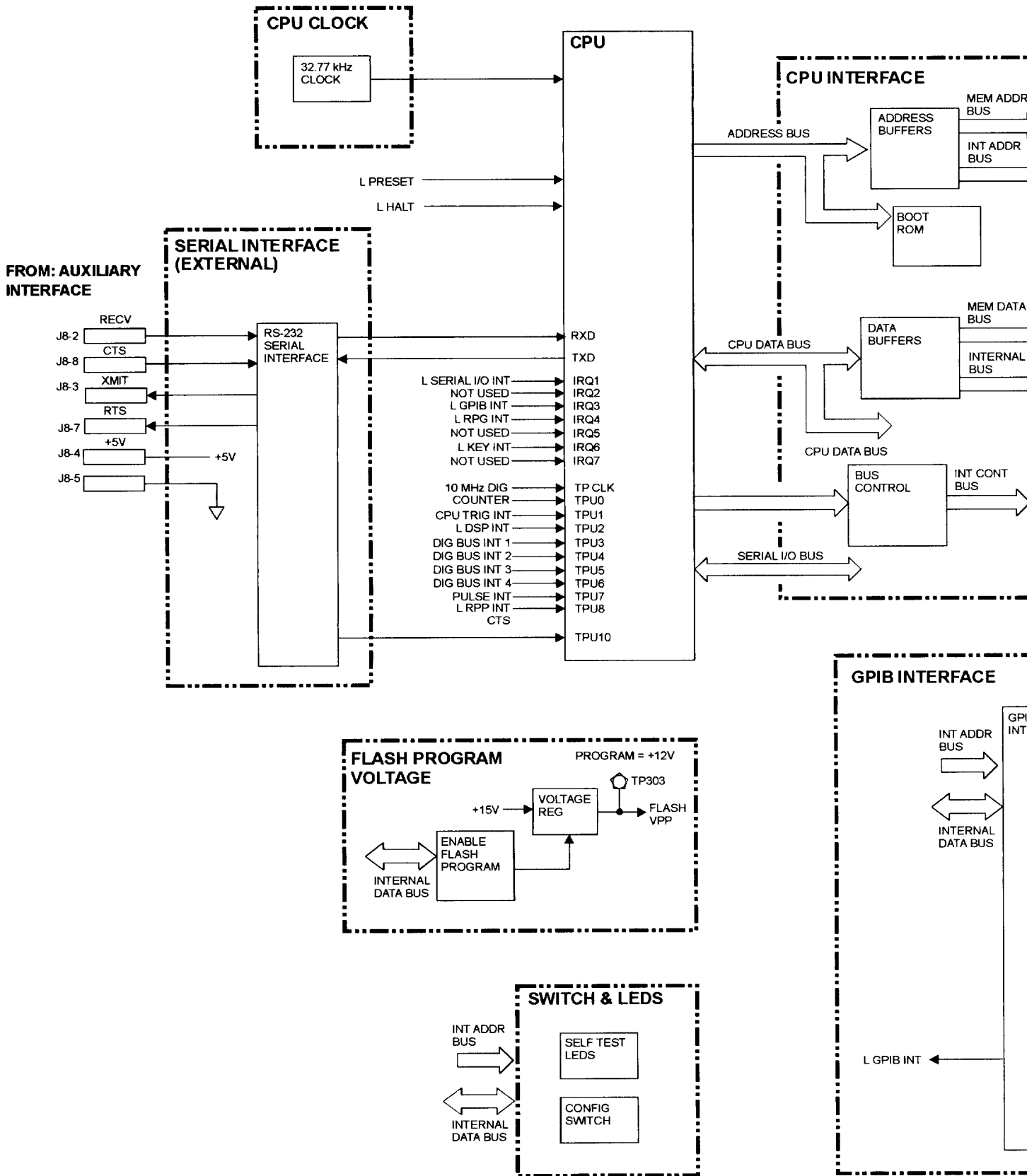

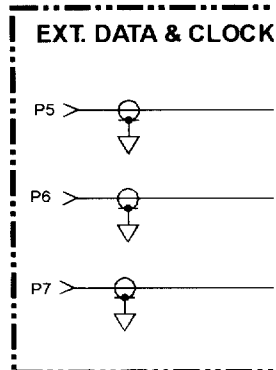
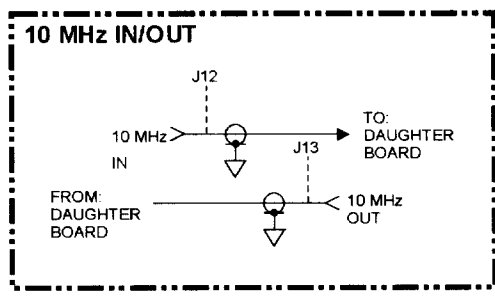
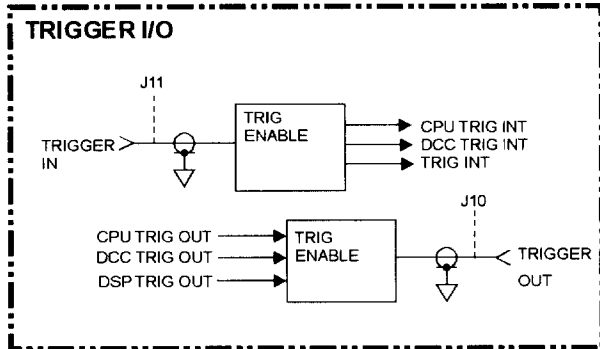
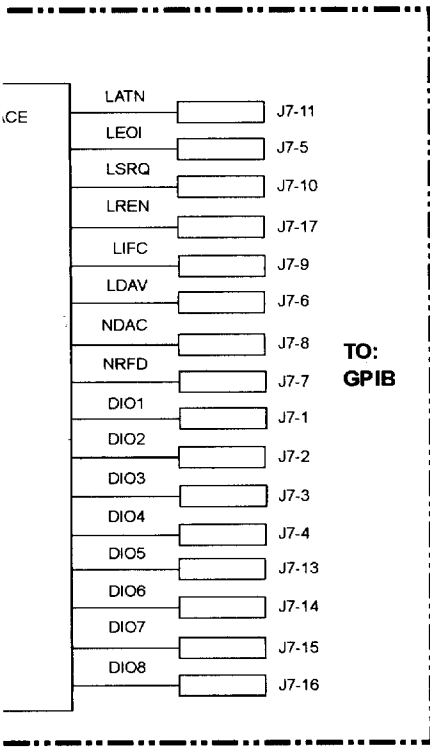
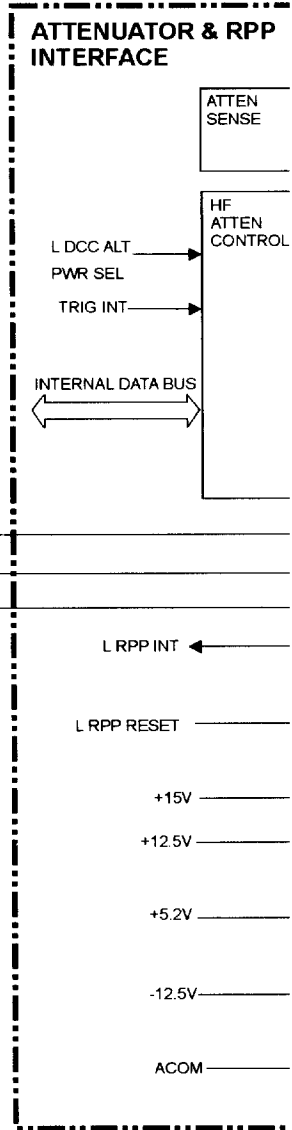
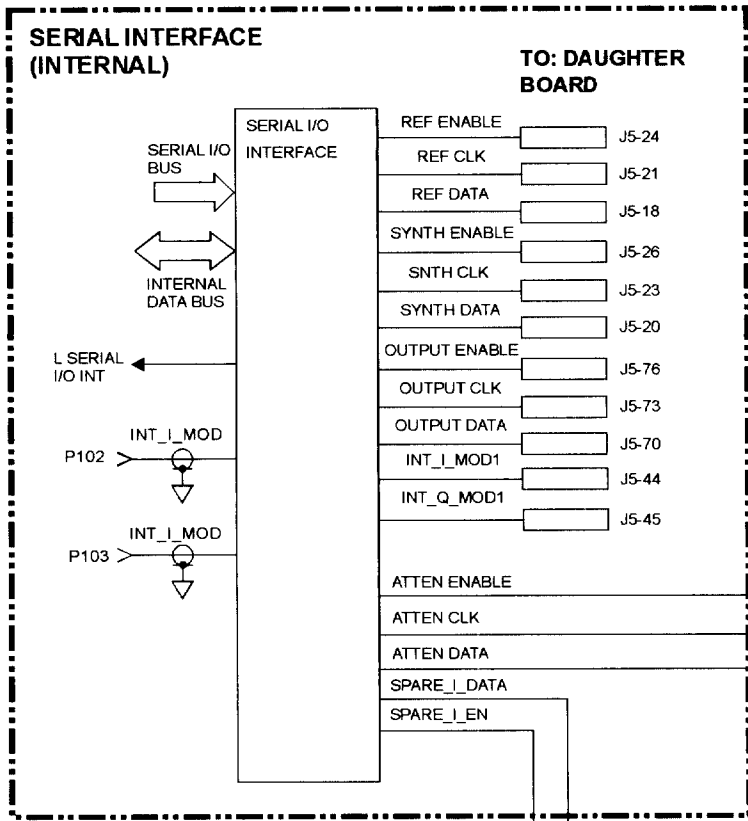
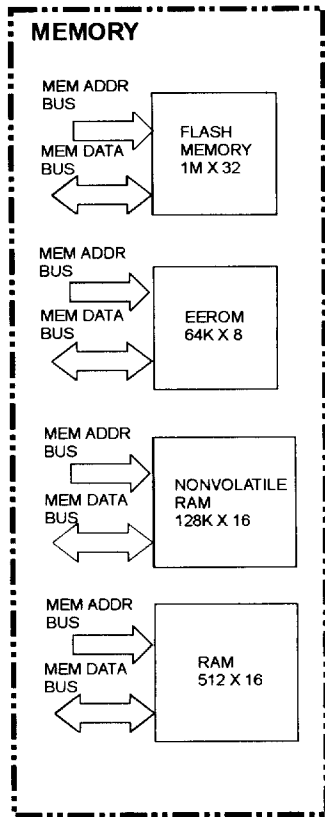

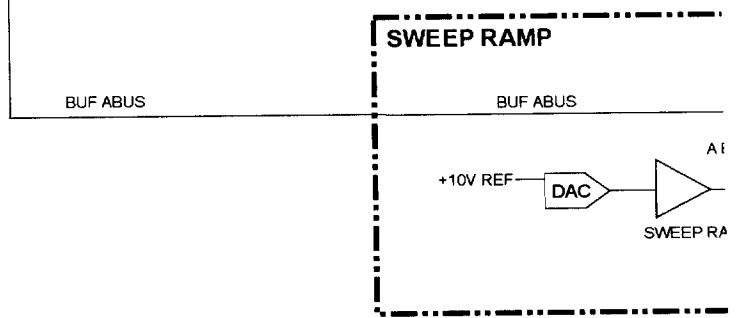
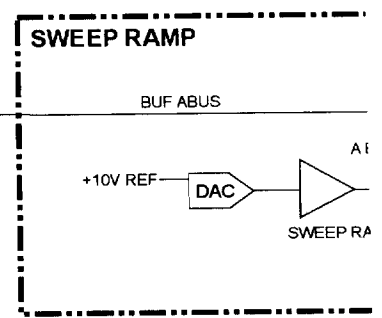
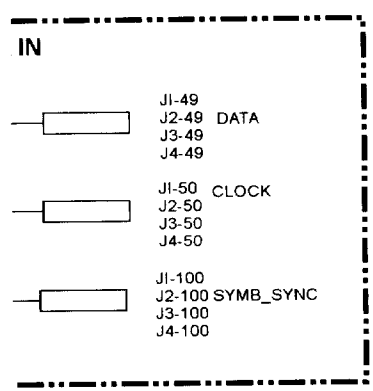
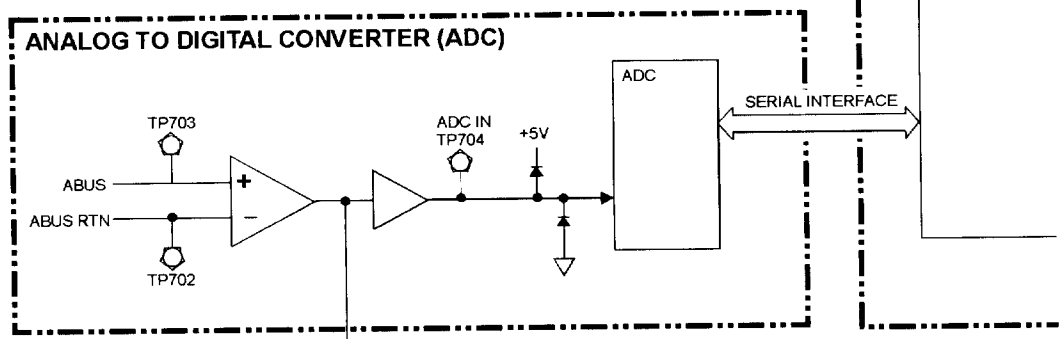
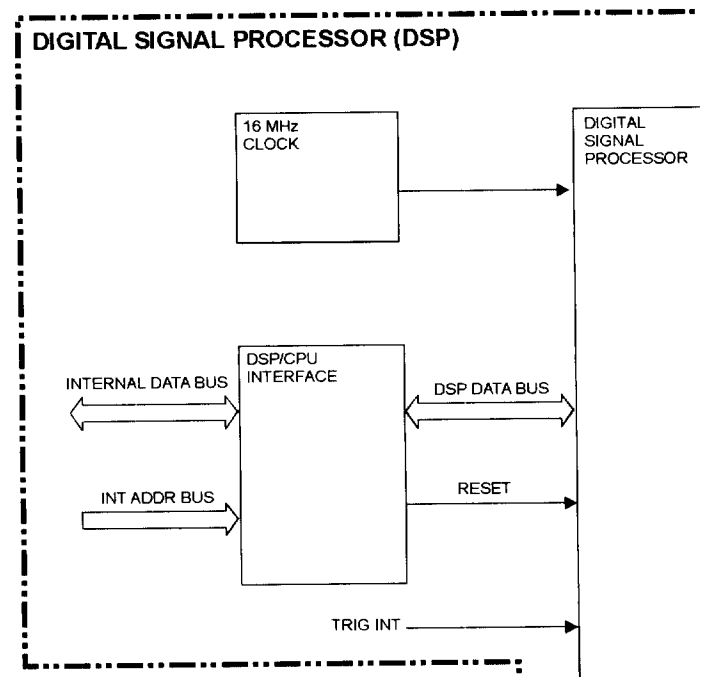
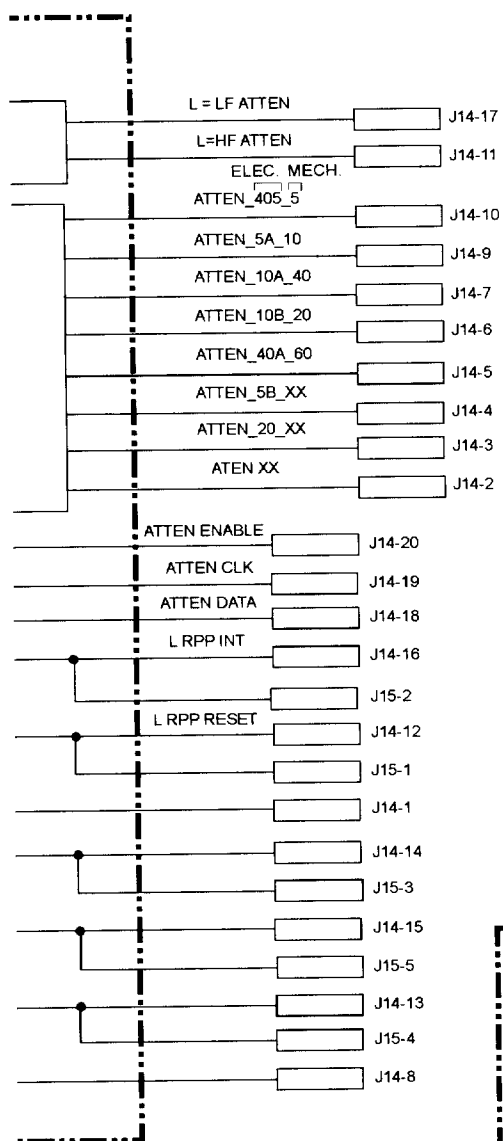

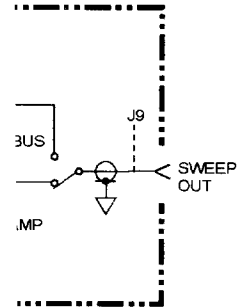
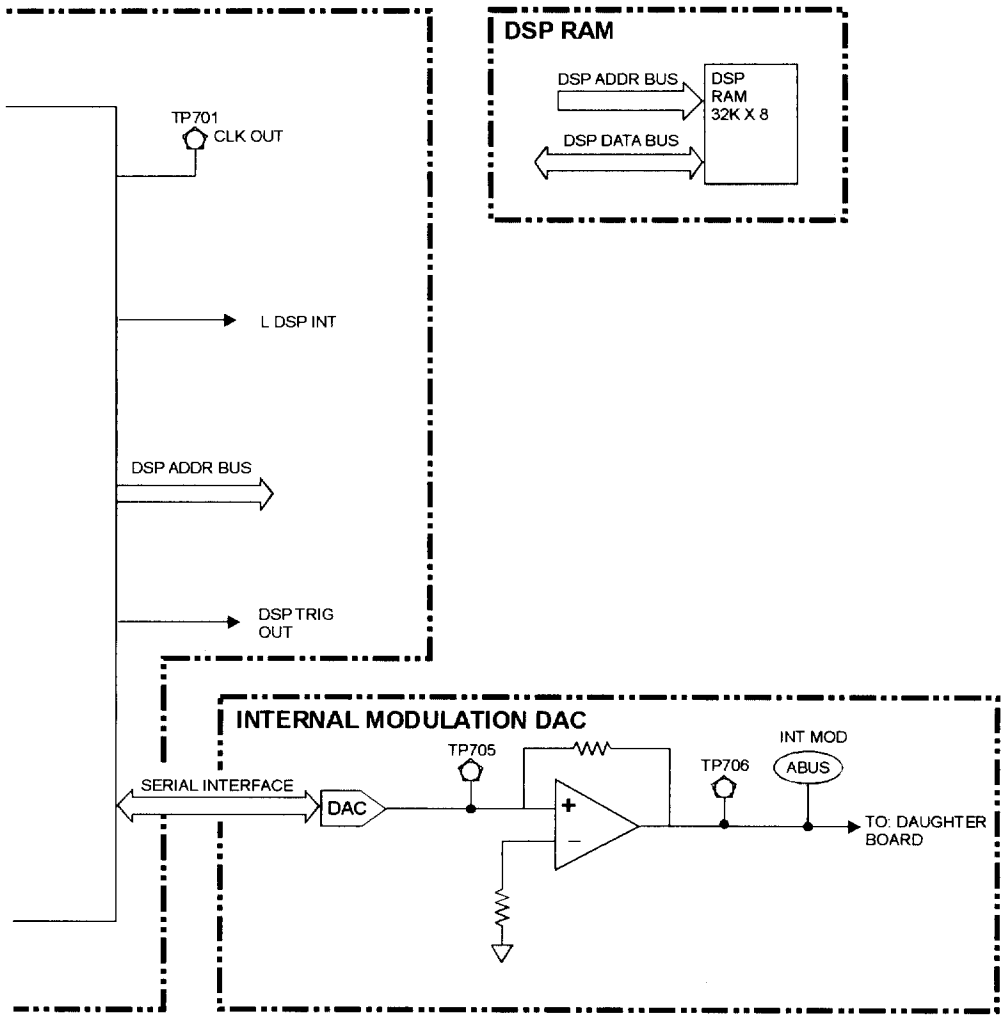

A14 CPU/MOTHERBOARD BLOCK DIAGRAM (1 OF 2)

A14 CPU/MOTHERBOARD BLOCK DIAGRAM (2 OF 2)

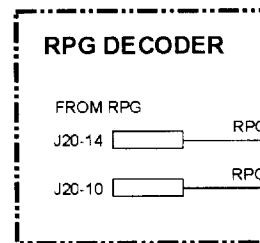
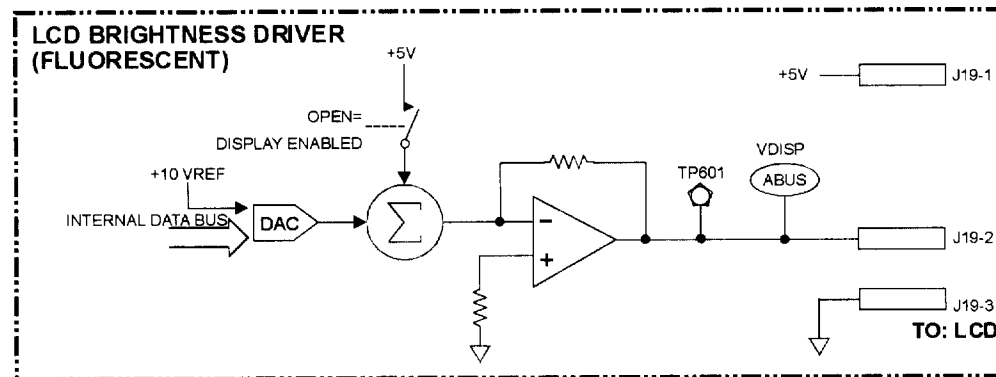
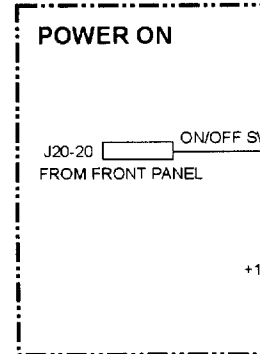
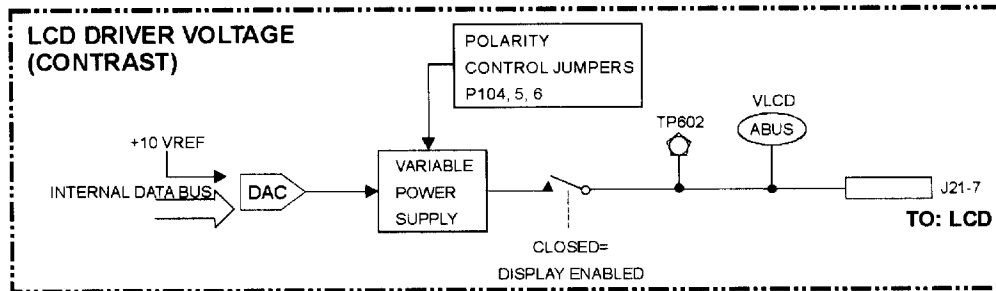
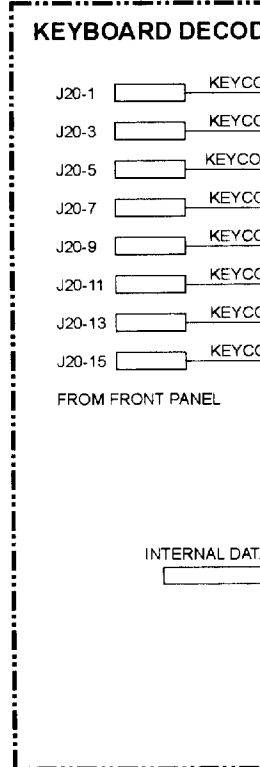
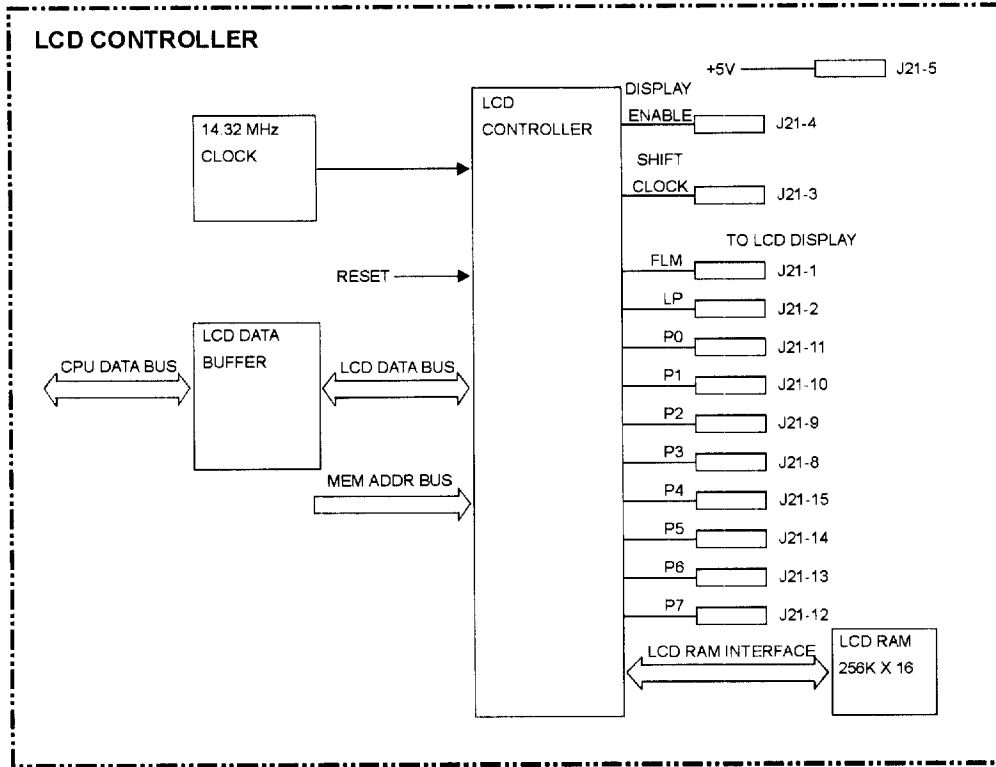

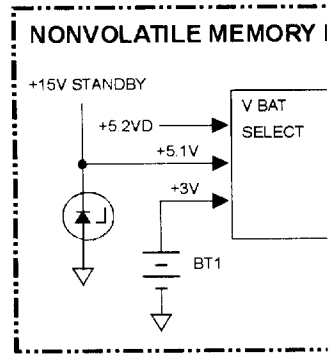
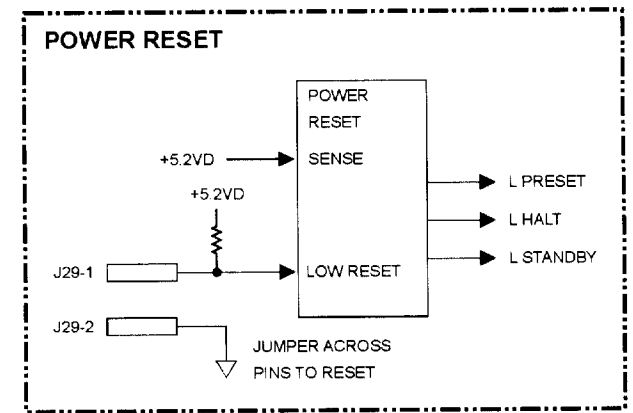
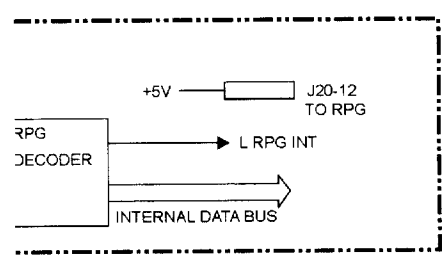
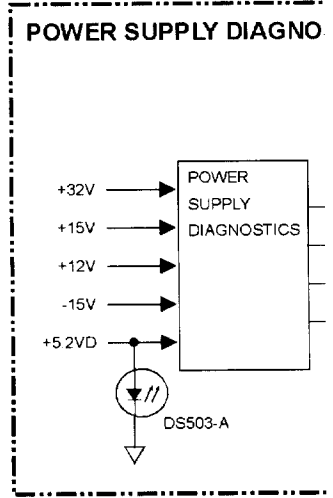
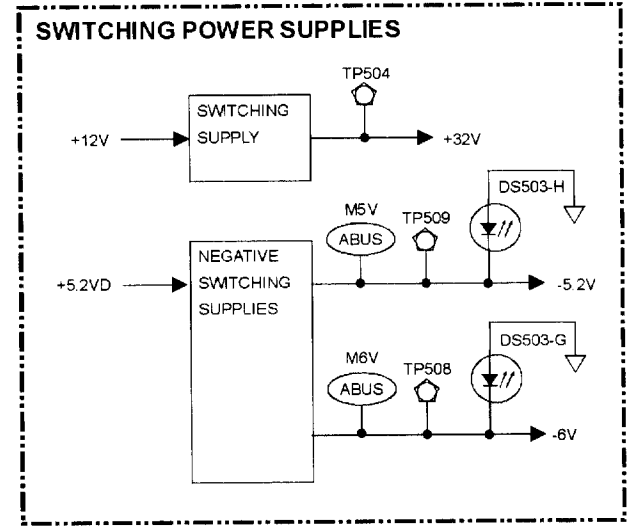
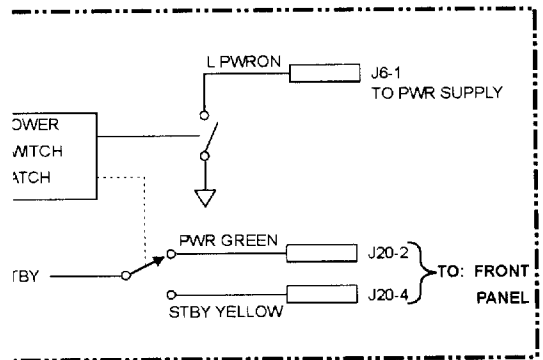
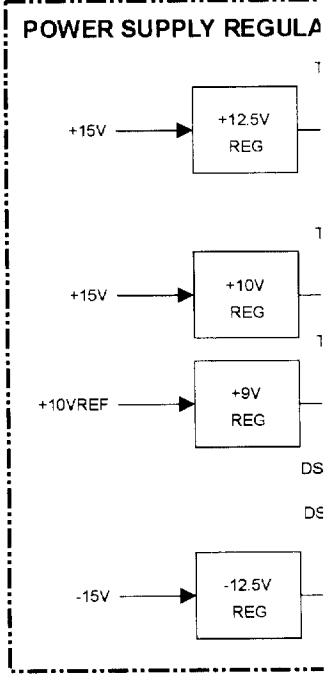
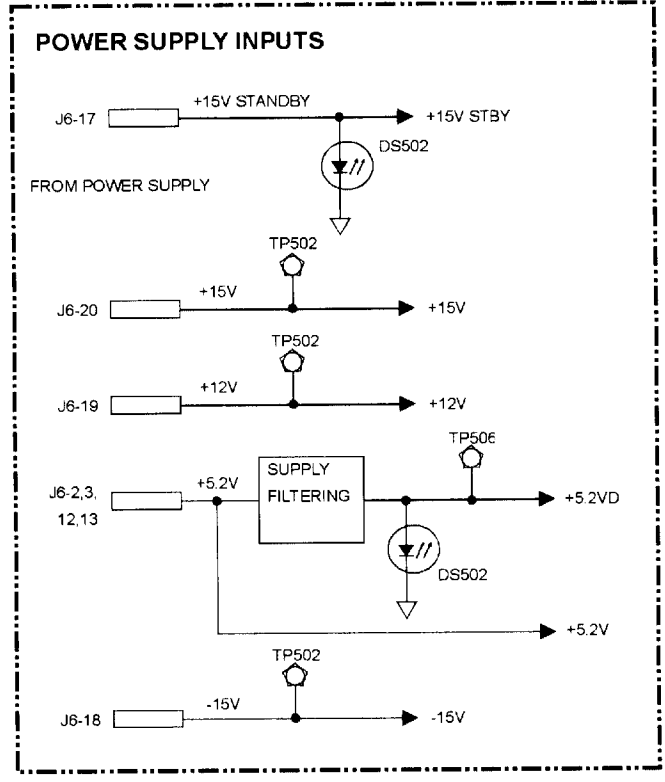
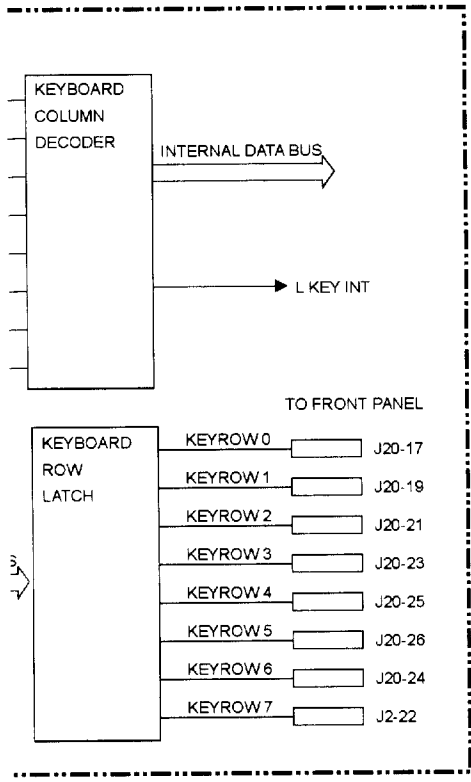

TORS

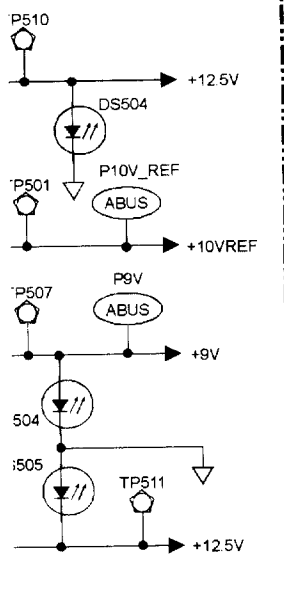

STICS

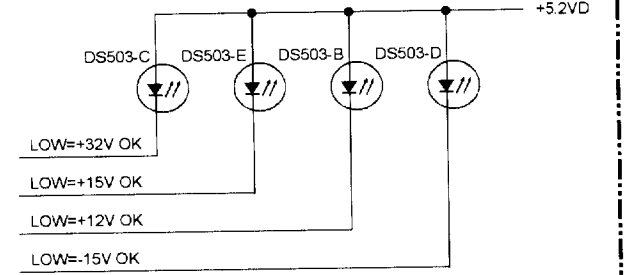

POWER

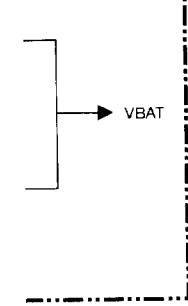

FAN POWER SUPPLY

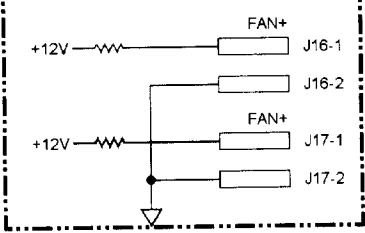

DIGITAL CARD CAGE CONNECTIONS

CPU INTERFACE

	MNEMONIC	J1	J2	J3	J4
INT ADDR BUS	IAB0	24	24	24	24
	IAB1	74	74	74	74
	IAB2	25	25	25	25
	IAB3	26	26	26	26
	IAB4	76	76	76	76
	IAB5	27	27	27	27
	IAB6	77	77	77	77
	IAB7	78	78	78	78
	IAB8	29	29	29	29
	IAB9	79	79	79	79
	IAB10	36	36	36	36
INT DATA BUS	EXT D0	19	19	19	19
	EXT D1	20	20	20	20
	EXT D2	70	70	70	70
	EXT D3	21	21	21	21
	EXT D4	71	71	71	71
	EXT D5	72	72	72	72
	EXT D6	23	23	23	23
	EXT D7	73	73	73	73
CONTROL BUS	EXT RESET	32			
	EXT RD L WR	83			
	EXT L STROBE	82			
	EXT SELECT 1	33			
	EXT SELECT 2		33		
	EXT SELECT 3			33	
	EXT SELECT 4				33
	DIG BUS INT 1	35			
	DIG BUS INT 2		35		
	DIG BUS INT 3			35	
DIG BUS INT 4				35	

CPU INTERFACE

MNEMONIC	J1
+PTAT	59
10 MHz DIG	84
ABUS	4
ABUS RTN	5
ALC GND	8
L ALC HOLD	31
AUD 1 (NOT USED)	6
AUD 2 (NOT USED)	55
BURST ENVELOPE	57
BURST PULSE	30
COUNTER	86
L DCC ALT PWR SEL	80
DCC TRIG OUT	18
DCC TRIG INT	85
FADE ENVELOPE	58
FM D0	47
FM D1	91
FM D2	95
FM D3	90
FM D4	96
FM D5	41
FM D6	89
FM D7	45
FM D8	39
FM D9	94
FM D10	88
FM D11	37
FM D12	92
FM D13	43
FM D14	38
FM D15	44
INT I MOD	2
INT I/Q MOD RTN	3,52
INT Q MOD	53
MOD STROB	97
PAREN SYNC	42
SWP READY	48
SWP STATUS	98
SWP RUN	49

POWER SUPPLIES

MNEMONIC	J1	J2	J3	J4
+32V	9	9	9	9
+15V	14,64	14,64	14,64	14,64
+12V	15,65	15,65	15,65	15,65
+5.2V	16,17	16,17	16,17	16,17
	66,67	66,67	66,67	66,67
-5.2V	12,62	12,62	12,62	12,62
-15V	13,63	13,63	13,63	13,63
DCOM	22,28	22,28	22,28	22,28
	34,40	34,40	34,40	34,40
	46,69	46,69	46,69	46,69
	75,81	75,81	75,81	75,81
	87,93	87,93	87,93	87,93
	99	99	99	99
ACOM	1,7	1,7	1,7	1,7
	54,56	54,56	54,56	54,56

DAUGHTER BOARD CONNECTIONS

J2	J3	J4
59	59	59
84	84	84
4	4	4
5	5	5
8	8	8
31	31	31
6	6	6
55	55	55
57	57	57
30	30	30
86	86	86
80	80	80
18	18	18
85	85	85
58	58	58
47	47	47
91	91	91
95	95	95
90	90	90
96	96	96
41	41	41
89	89	89
45	45	45
39	39	39
94	94	94
88	88	88
37	37	37
92	92	92
43	43	43
38	38	38
44	44	44
2	2	2
3,52	3,52	3,52
53	53	53
97	97	97
42	42	42
48	48	48
98	98	98
49	49	49

SERIAL I/O

MNEMONIC	J5
REF DATA	18
REF CLK	21
REF ENABLE	24
SYNTH DATA	20
SYNTH CLK	23
SYNTH ENABLE	26
OUTPUT DATA	70
OUTPUT CLK	73
OUTPUT ENABLE	76

POWER SUPPLIES

MNEMONIC	J5
+32V	83
+15V	32,82
+15V STBY	33
+9V	34,84
+5.2V	30,31 80,81
-5.2V	35,85
-6V	37,87
-15V	36,86
DCOM	4,10 16,22 28,51 57,63 69,75
ACOM	43,47 49,96

SIGNALS

MNEMONIC	J5
+PTAT	40
10 MHz IN	97
10 MHz OUT	99
10 MHz RTN	98,100
ABUS	93
ABUS RTN	92
ALC GND	91
L ALC HOLD	17
L ALT PWR SEL	29
AUD 1 (NOT USED)	48
AUD 2 (NOT USED)	46
BURST ENVELOPE	42
BURST PULSE	79
COUNTER	15
FADE ENVELOPE	41
FM D0	55
FM D1	60
FM D2	56
FM D3	11
FM D4	5
FM D5	61
FM D6	62
FM D7	6
FM D8	12
FM D9	7
FM D10	13
FM D11	14
FM D12	59
FM D13	8
FM D14	64
FM D15	58
INT MOD	50
INT I MOD	44
INT I/Q MOD RTN	45,94
INT Q MOD	95
MOD STROB	54
PAREN SYNC	9
SWP READY	3
SWP STATUS	53
SWP RUN	2

A23 SAMPLER (ESG-AP AND ESG DP SERIES)

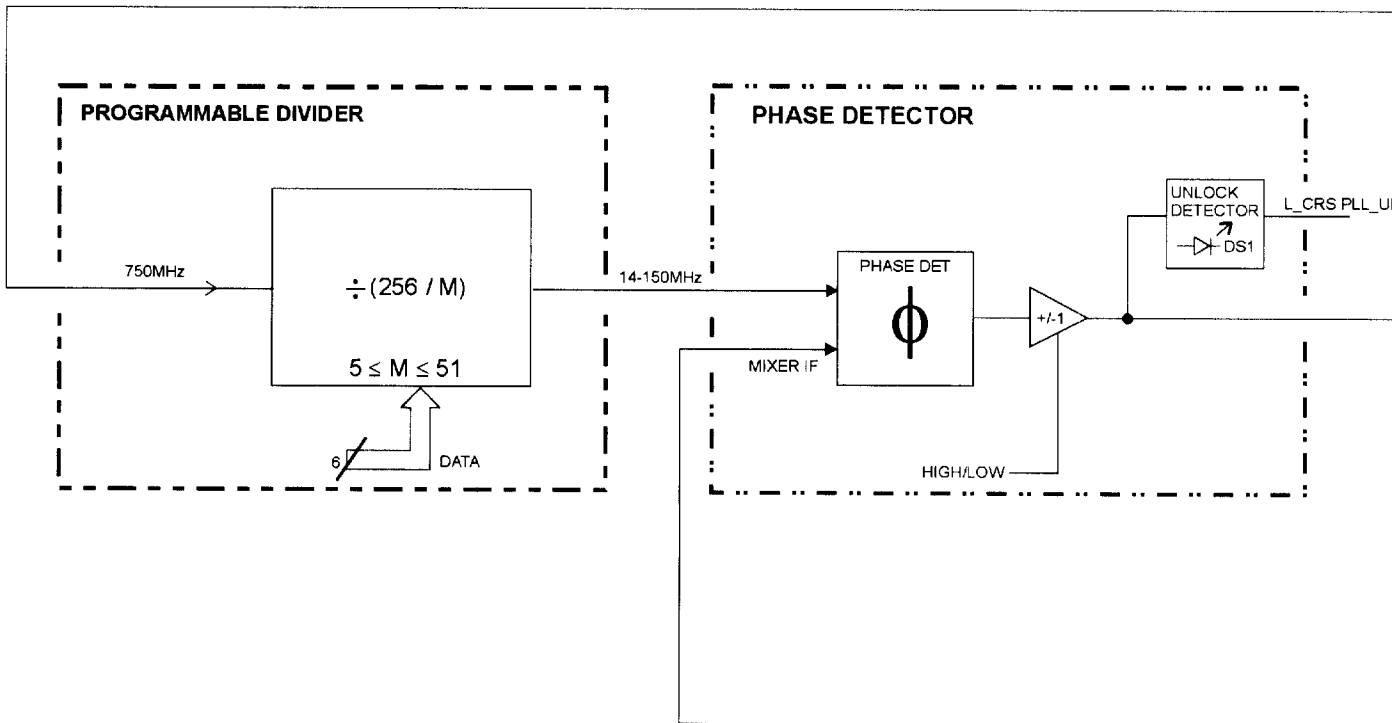
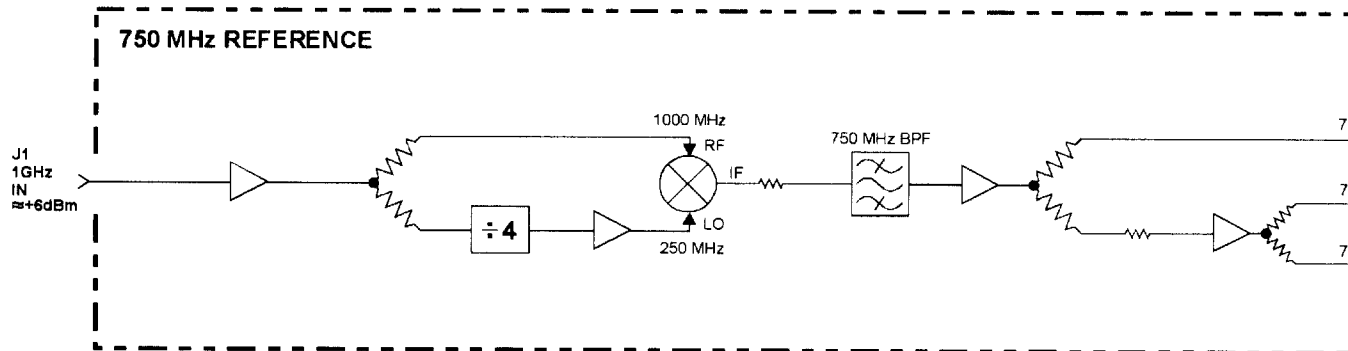

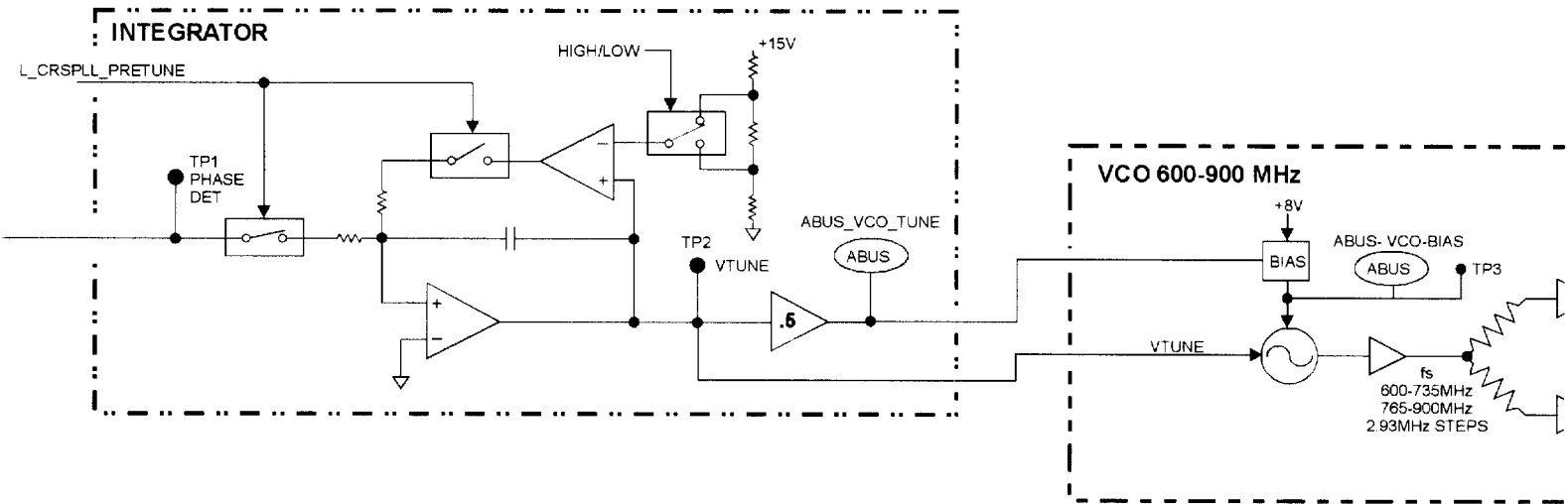
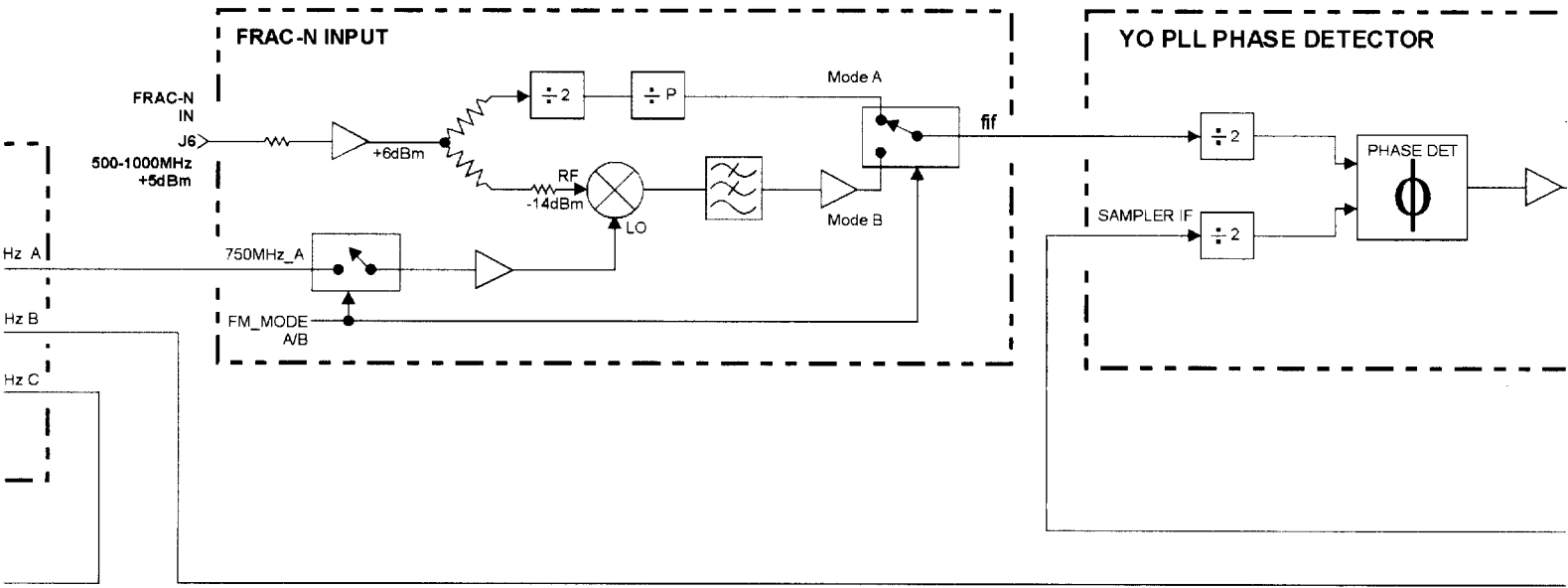

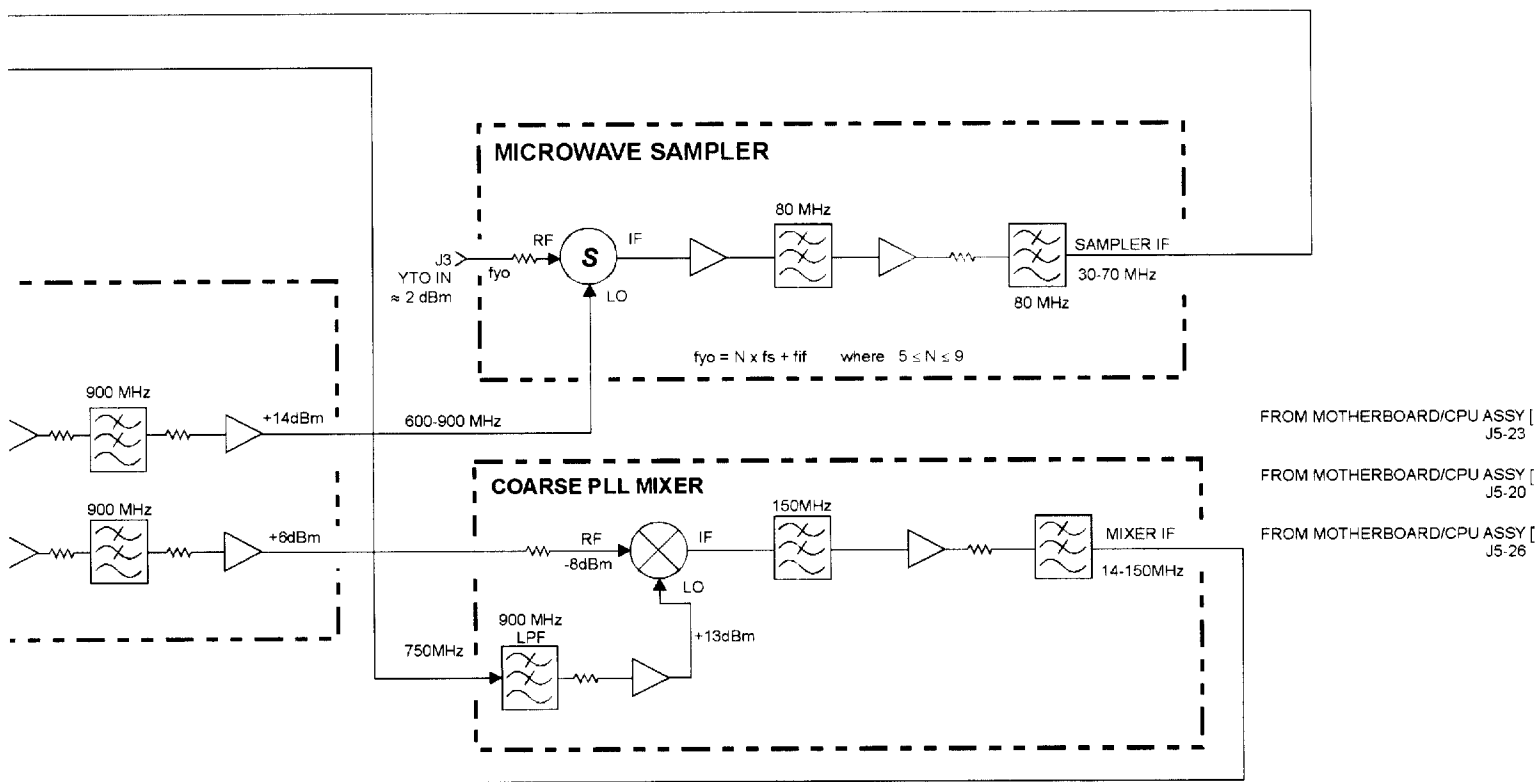
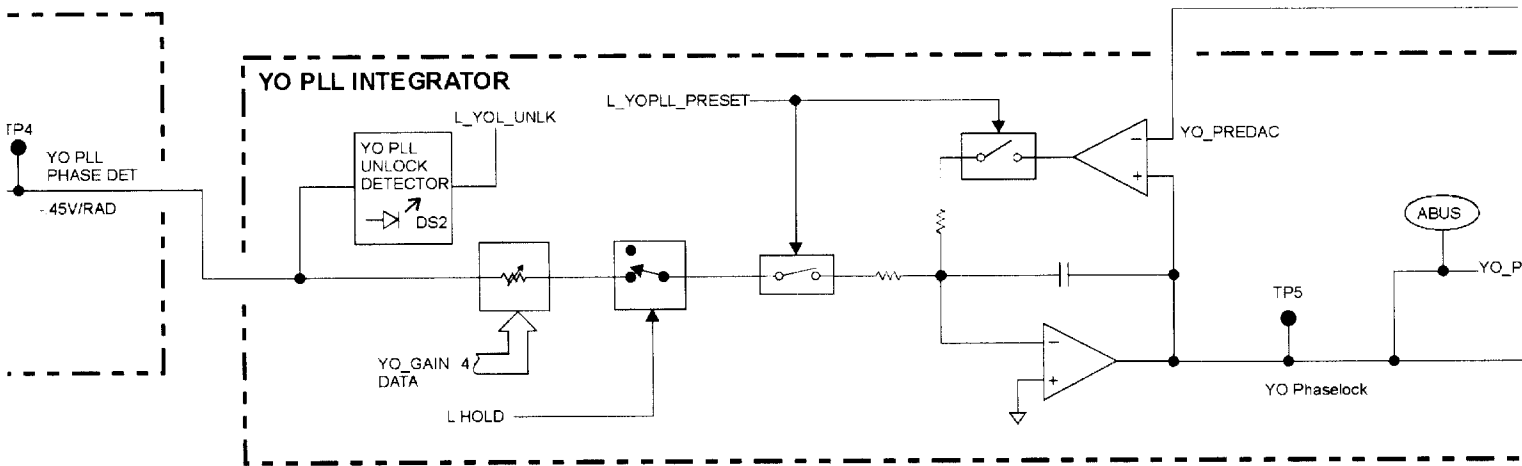

ABUS [

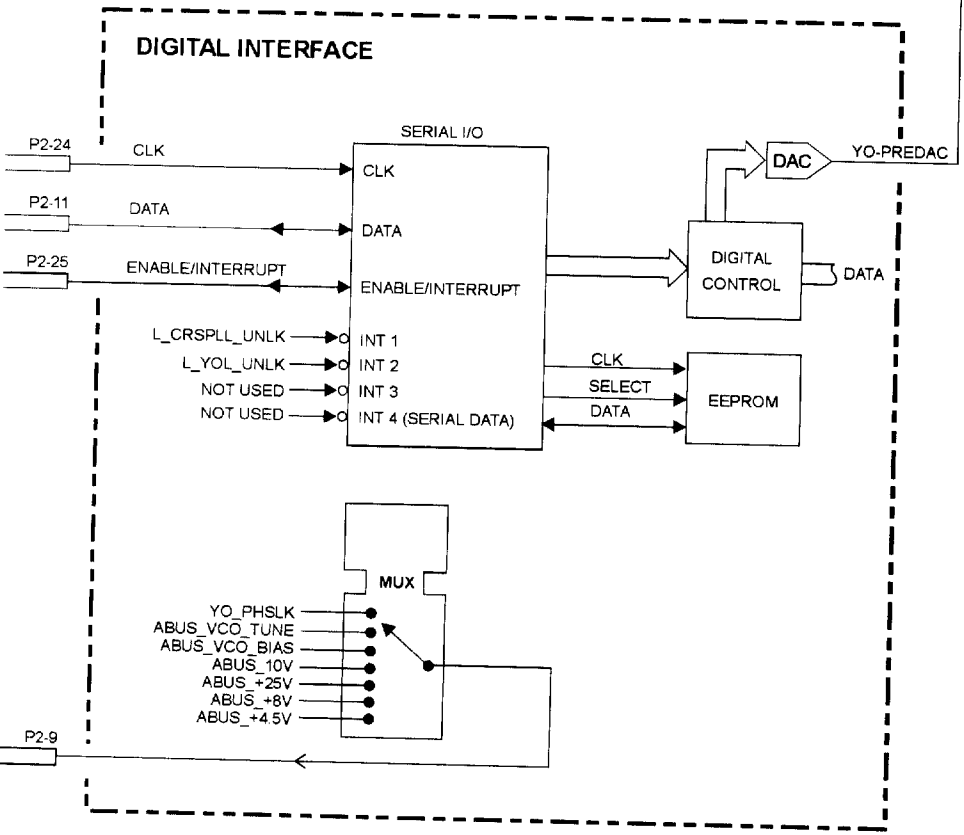
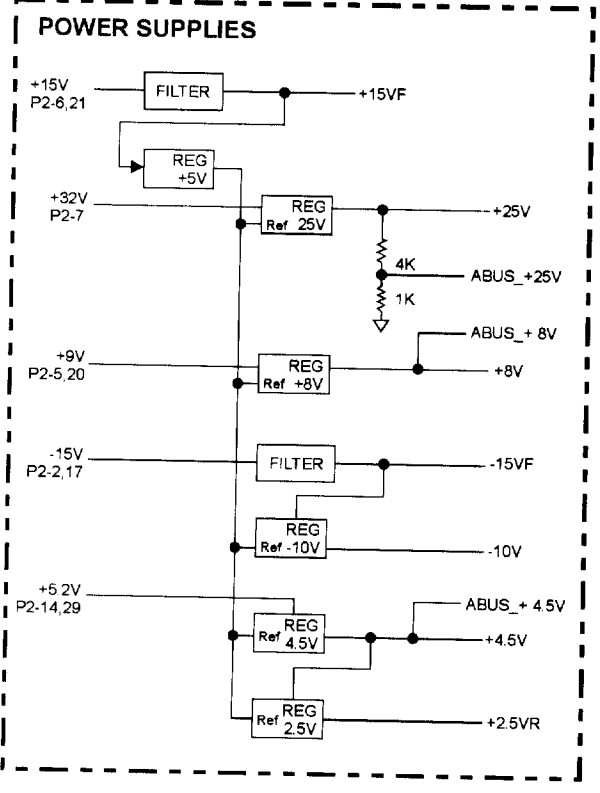
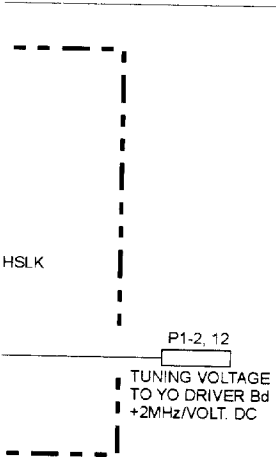

A23 SAMPLER (ESG-AP AND ESG DP SERIES)

A24 FRAC-N/DIVIDER (ESG-AP & ESG-DP SERIES)

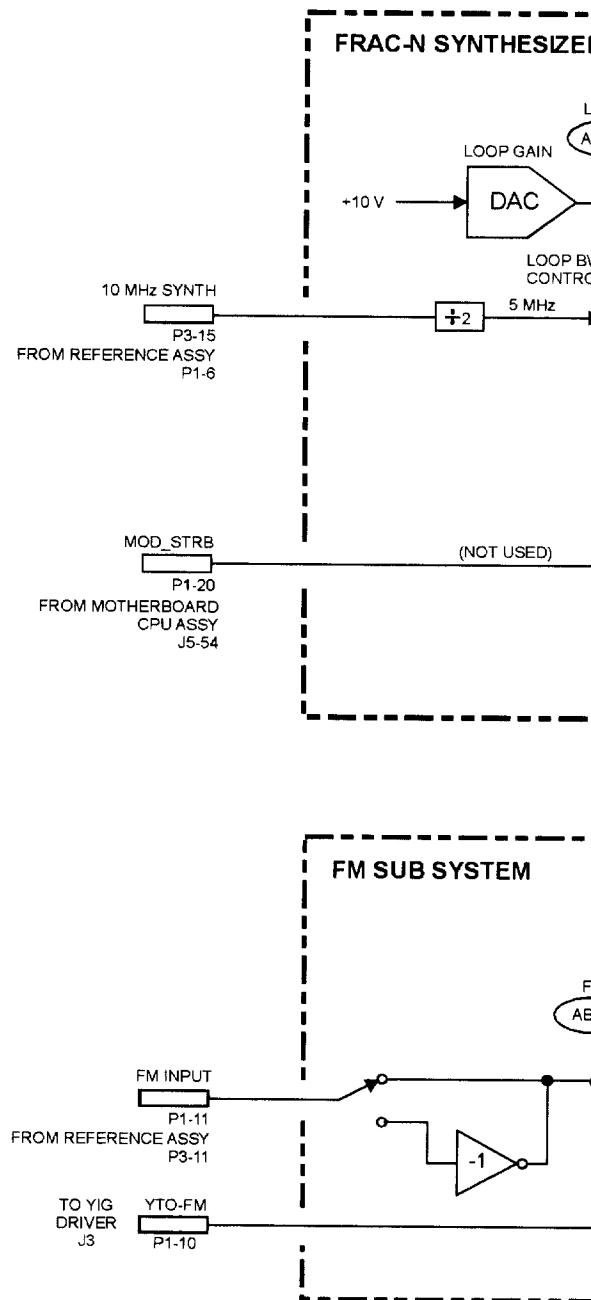

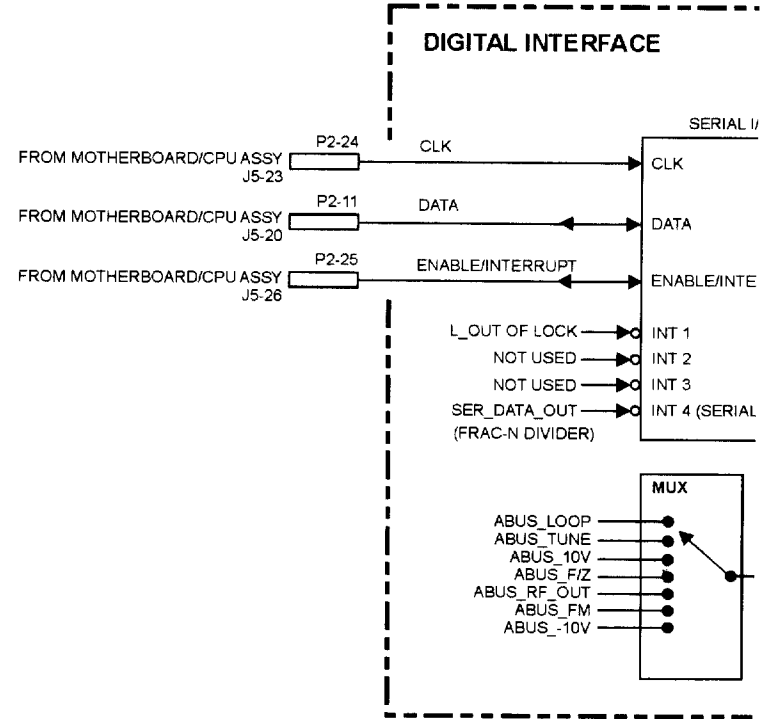
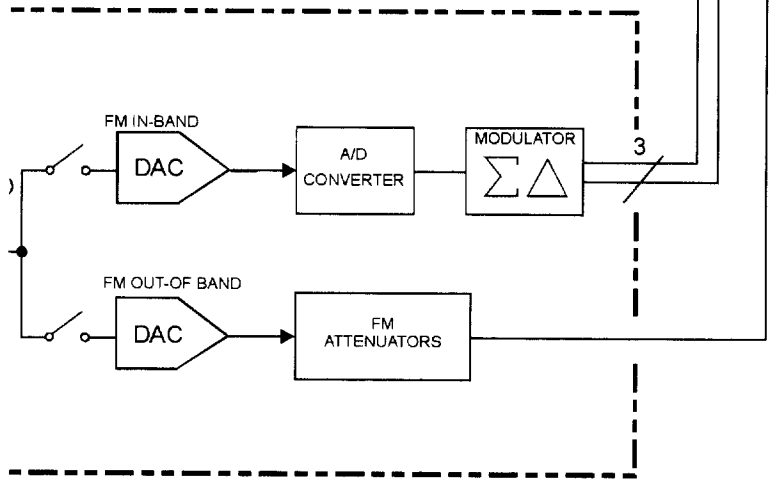
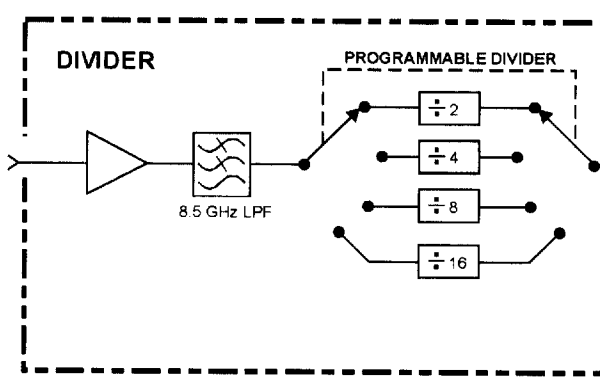
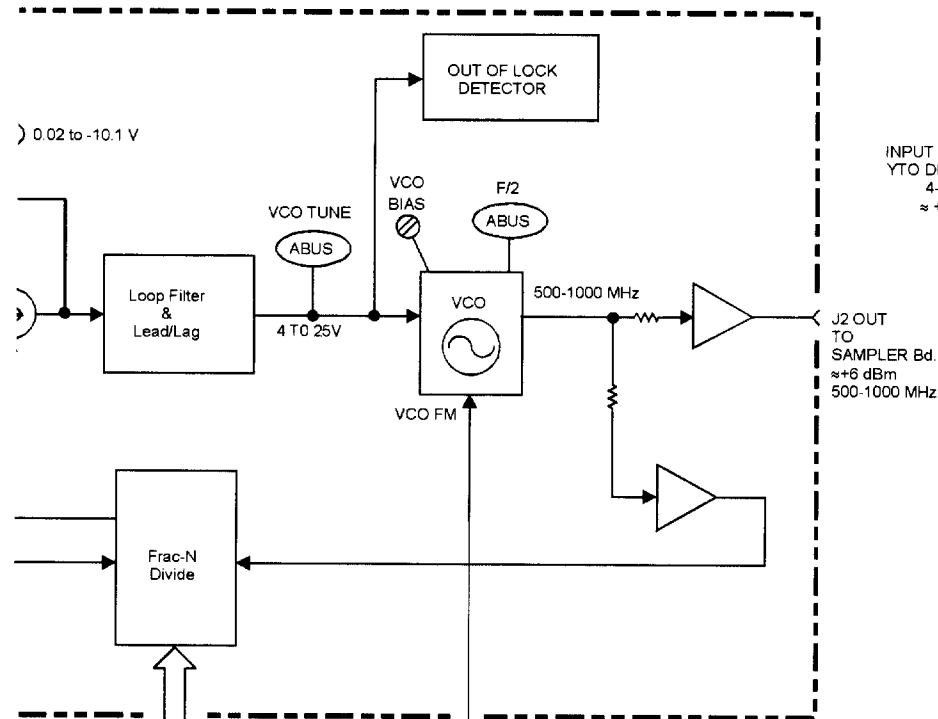

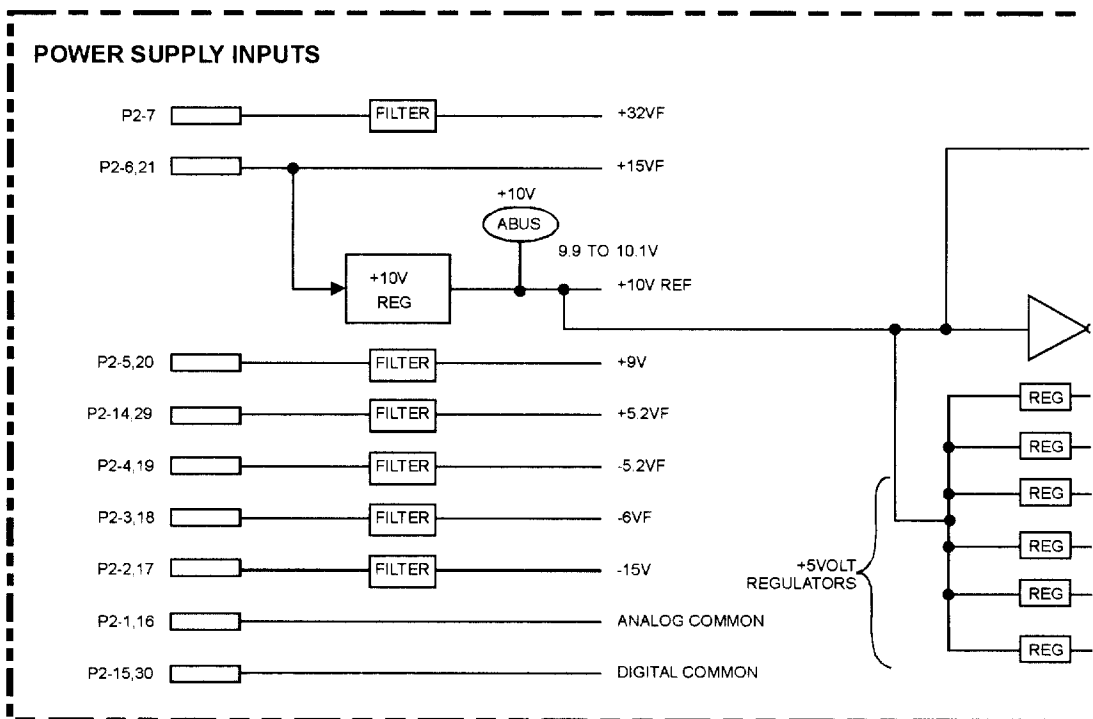
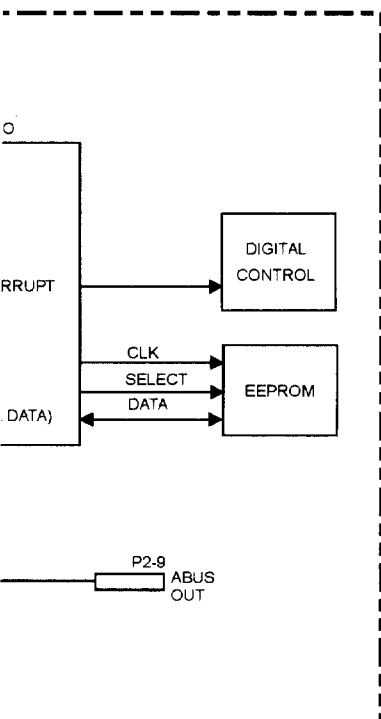
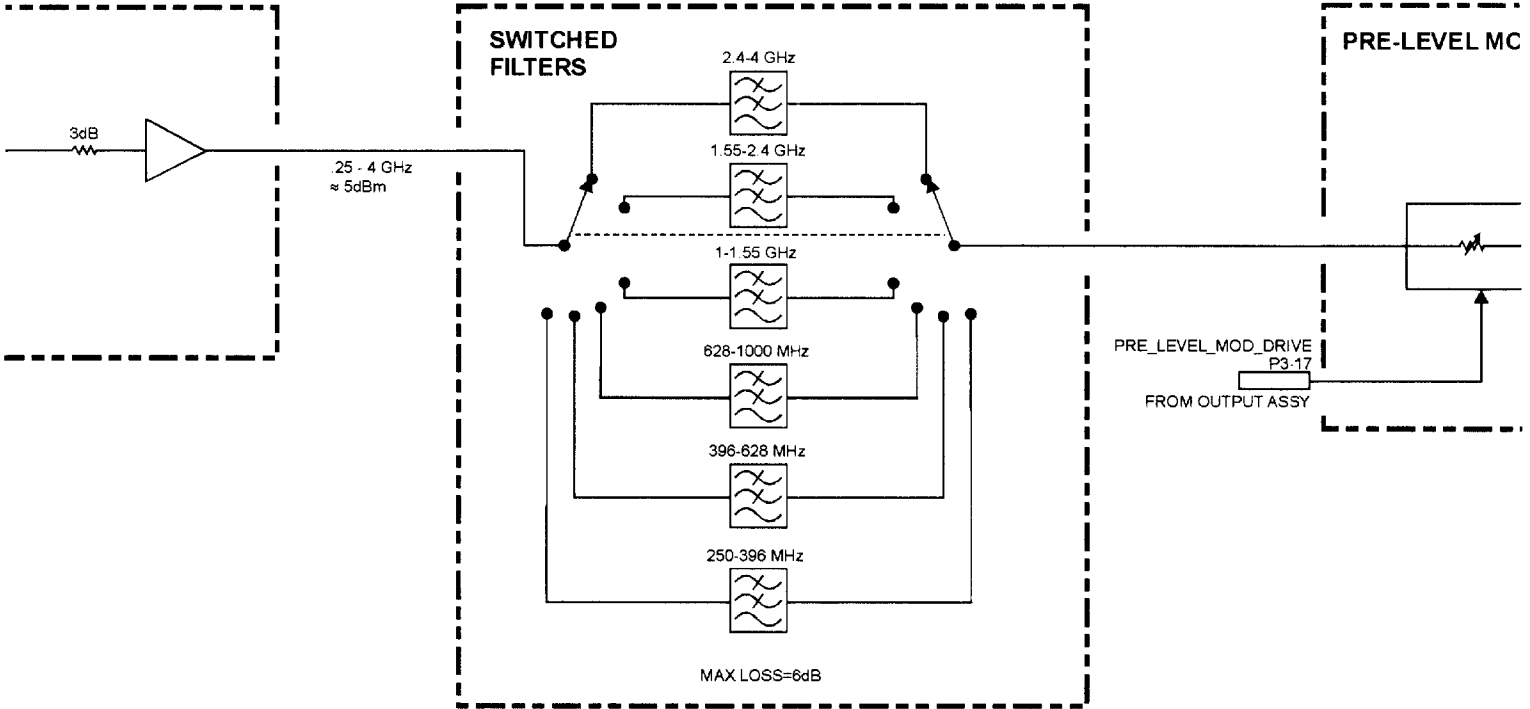

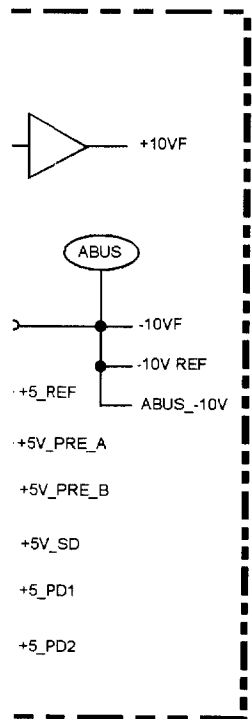
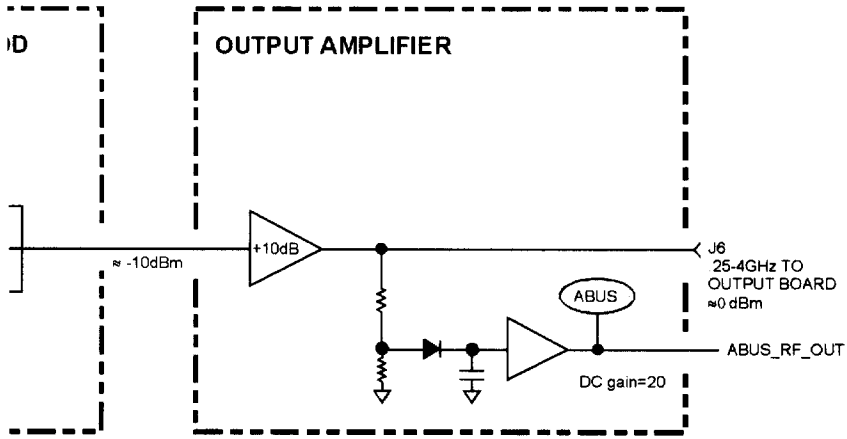

A24 FRAC-N/DIVIDER (ESG-AP & ESG-DP SERIES)

ESG-A SERIES POWER SUPPLY AND GROUND INTERCONNECTS

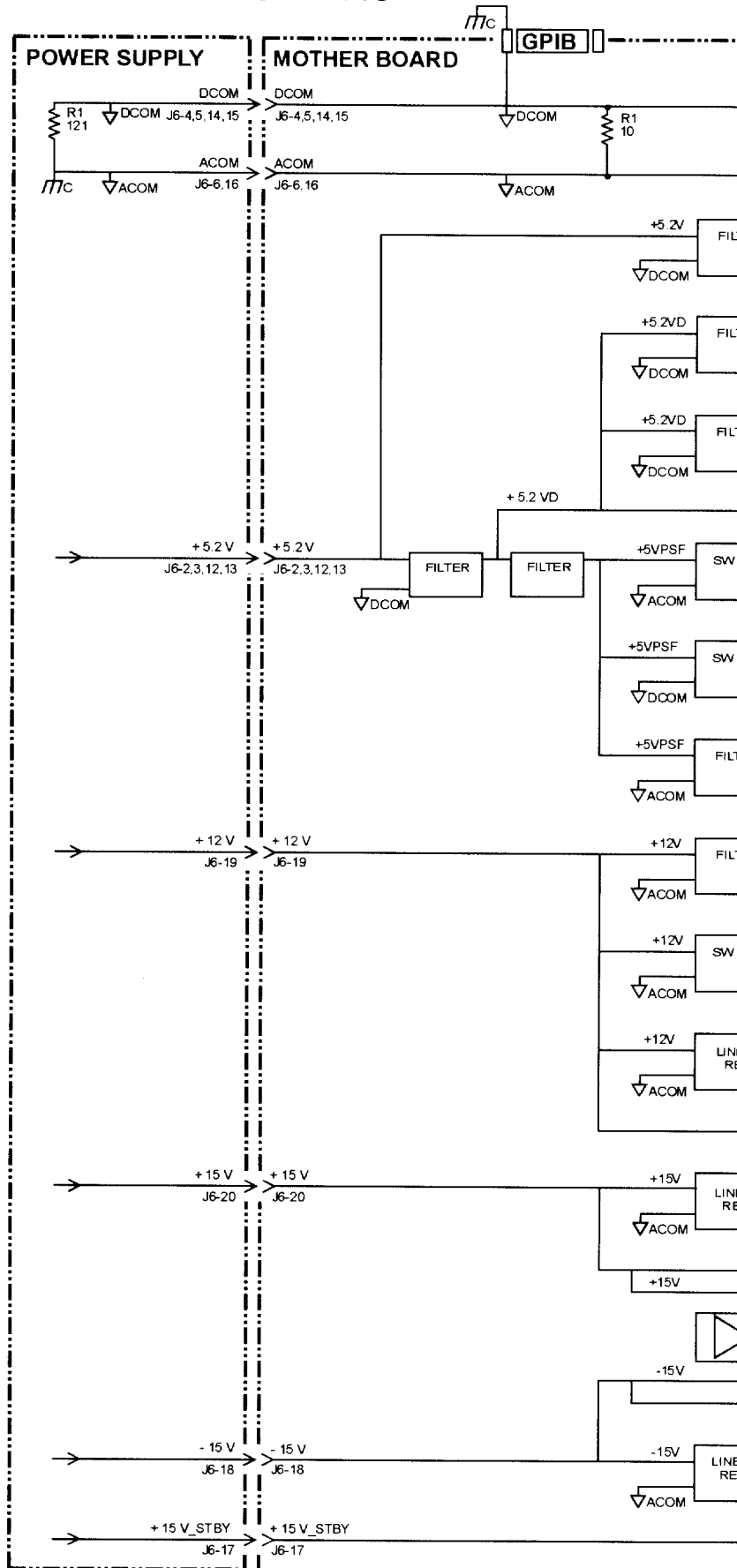

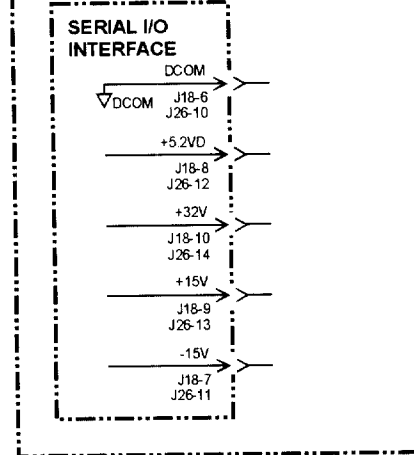
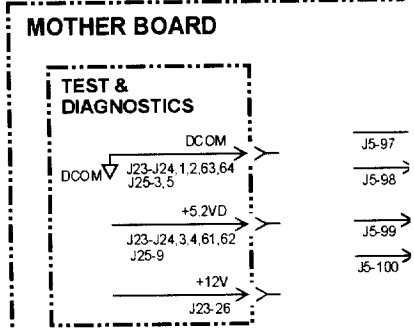
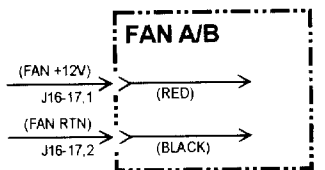
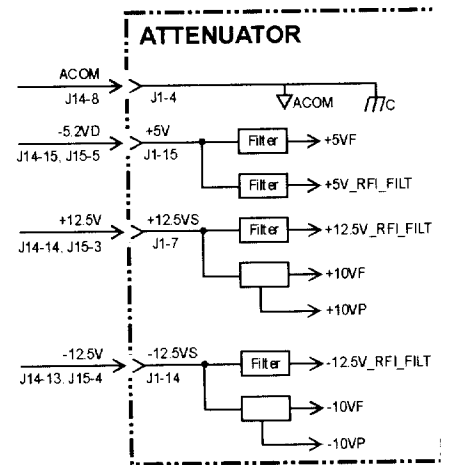
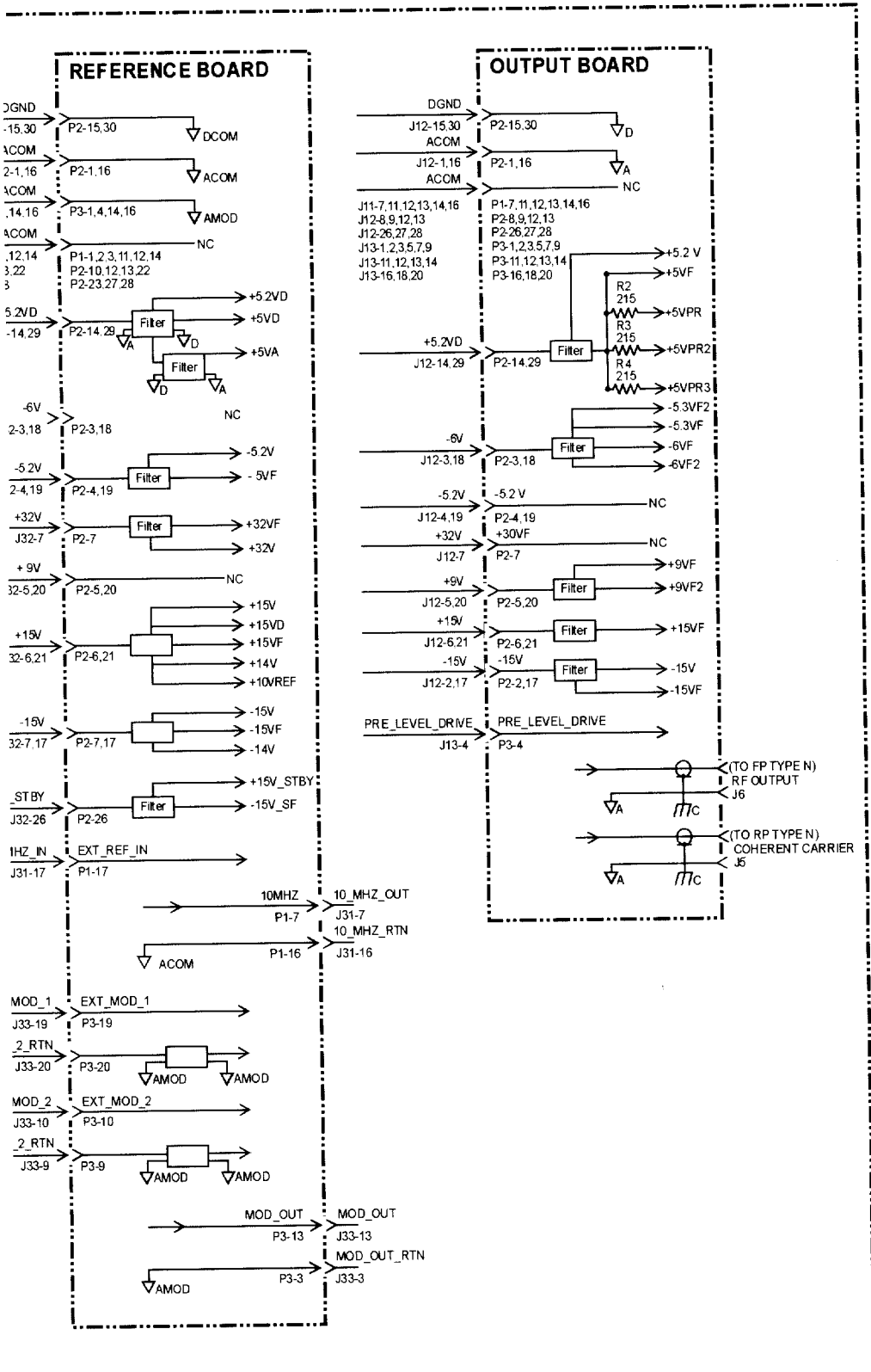

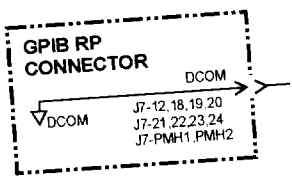
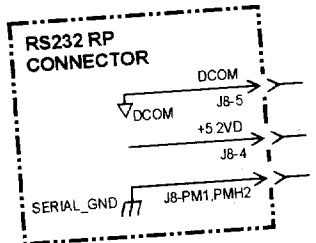
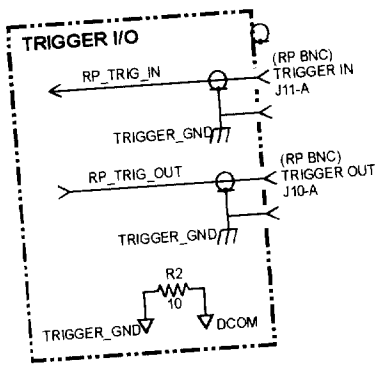
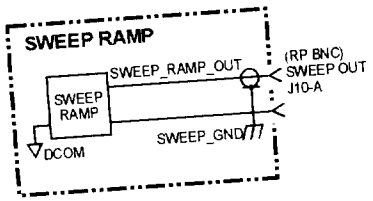
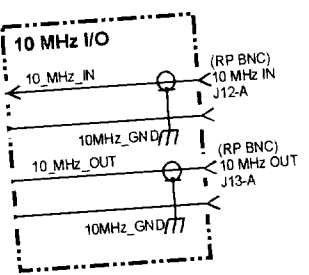
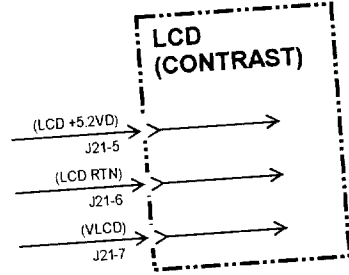
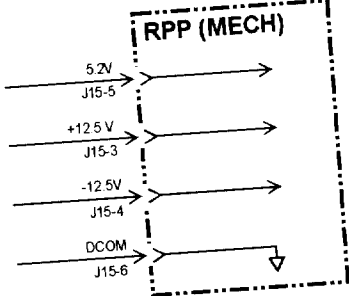
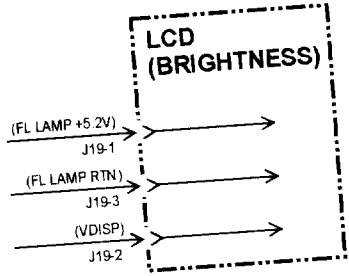
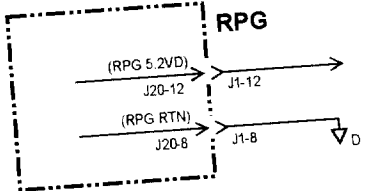
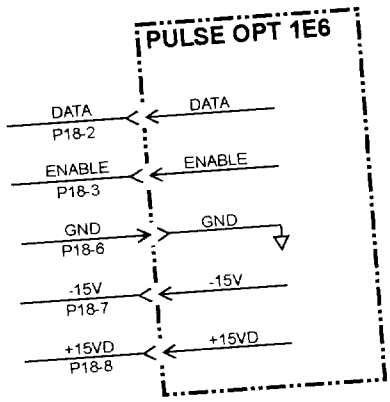

5G-A SERIES POWER SUPPLY AND GROUND INTERCONNECTS