
User and Service Guide

Publication number 01153-97002
March 2000

For Safety information, Warranties, and Regulatory information,
see the pages at the back of this guide

© Copyright Agilent Technologies 1997-2000
All Rights Reserved

1153A Differential Probe

1153A Differential Probe

The 1153A Differential Probe allows measurement of small differential signals in the presence of much larger common-mode signals. The probe has the following major features:

- 200 MHz bandwidth
- AutoProbe probe interface
- Variable offset
- Lf (low frequency) reject
- Ac coupling

The variable offset capability can be used to measure small ac signals in the presence of much larger dc levels.

The probe can be used with instruments employing the Agilent AutoProbe probe interface, such as the Infiniium family of oscilloscopes.

Accessories Supplied

The following accessories are supplied. See "Accessories supplied" in chapter 1 for a complete list.

- 10:1 attenuator adapter
- 100:1 attenuator adapter
- Ac coupling attenuator adapter
- Miscellaneous small accessories
- Carrying case

Accessories Available

The following accessories can be ordered.

- 10100C 50 Ω Feedthrough termination
- 5959-9335 Long extension lead (5.5 inch/14 cm), package of 5
- 5090-4356 SMT clip, package of 20
- 10467-68701 Micro Clip, package of 4

1	General Information	
2	Operating the probe	
3	Service	
	Index	

In This Book

This guide provides user and service information for the 1153A Differential Probe.

Chapter 1 gives you general information such as inspection, cleaning, accessories supplied, and specifications and characteristics of the probe.

Chapter 2 shows you how to operate the probe.

Chapter 3 provides service information.

1 General Information

To inspect the probe 1-3
To clean the probe 1-3
Accessories supplied 1-4
Accessories available 1-6



Performance specifications 1-7
Performance characteristics 1-9
General characteristics 1-10

2 Operating the probe

Using the accessories 2-3
Grounding 2-8
Coupling functions 2-9
Differential amplifiers and CMRR 2-11

3 Service

Safety 3-2
Service Strategy 3-2
To return the probe to Agilent Technologies for service 3-3

Probe troubleshooting 3-4
Preparing the probe for troubleshooting 3-4
Troubleshooting the probe 3-5

Removing and replacing assemblies 3-6
Differential probe 3-6
Probe adapters 3-9

Replaceable parts 3-11
Ordering replaceable parts 3-11
Replaceable parts 3-12



General Information

Introduction

This chapter covers the following information:

- Inspection
- Cleaning
- Accessories supplied
- Accessories available
- Performance specifications
- Performance characteristics
- General characteristics



To inspect the probe

- Inspect the shipping container for damage.

Keep a damaged shipping container or cushioning material until the contents of the shipment have been checked for completeness and the instrument has been checked mechanically and electrically.

- Check the accessories.

Accessories supplied with the instrument are listed in "Accessories Supplied" in table 1-1 later in this chapter.

- If the contents are incomplete or damaged notify your Agilent Technologies sales office.

- Inspect the instrument.

- If there is mechanical damage or defect, or if the instrument does not operate properly or pass performance tests, notify your Agilent Technologies sales office.
 - If the shipping container is damaged, or the cushioning materials show signs of stress, notify the carrier as well as your sales office. Keep the shipping materials for the carrier's inspection. The Agilent Technologies office will arrange for repair or replacement at Agilent Technologies-Packard's option without waiting for claim settlement.

To clean the probe

If this probe requires cleaning, disconnect it from the oscilloscope and clean it with a mild detergent and water. Make sure the instrument is completely dry before reconnecting it to the oscilloscope.

Accessories supplied

The following items are supplied as part of the 1153A probe. Item numbers refer to the numbers in figures 1-1 and 1-2.

Table 1-1

Accessories supplied with Probe System

Item	Description	Qty	Agilent Part Number
1	Differential Probe	1	—
2	10:1 Attenuator Adapter	1	5063-2144
3	100:1 Attenuator Adapter	1	5063-2145
4	ac Coupling Adapter	1	5063-2146
5	Two-inch Extension Leads (package of 5)	1	5959-9334
6	Mini Clips	20	5959-0288
7	Five-inch Ground Lead	1	5061-6162
8	Shielded Signal Lead	1	01141-68702
9	Test Board	1	01141-66504
10	Flat-blade Alignment Tool	1	8710-1961
11	Circuit Connection Posts (strip of 20)	1	1251-5943

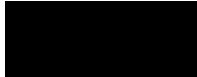
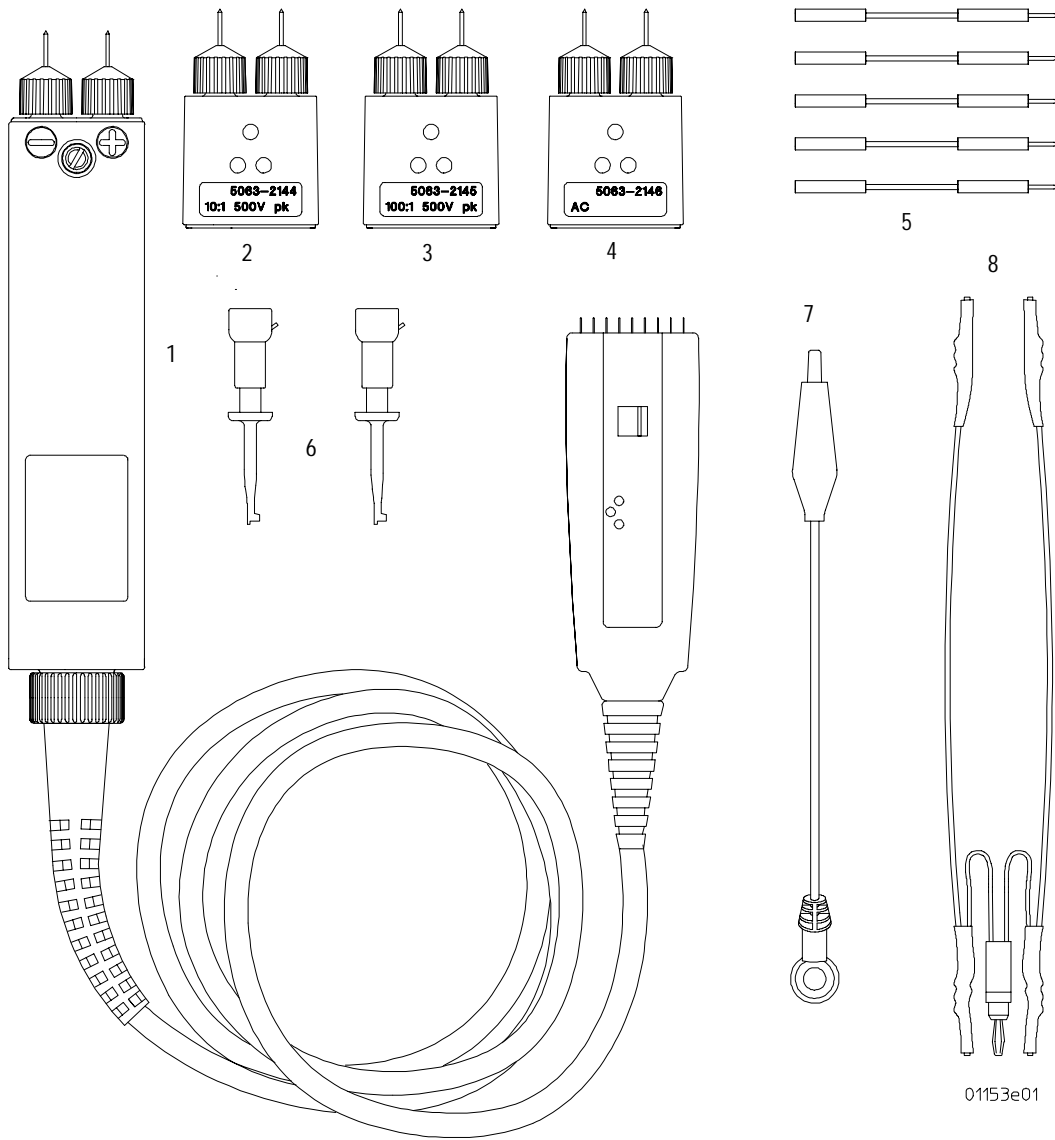
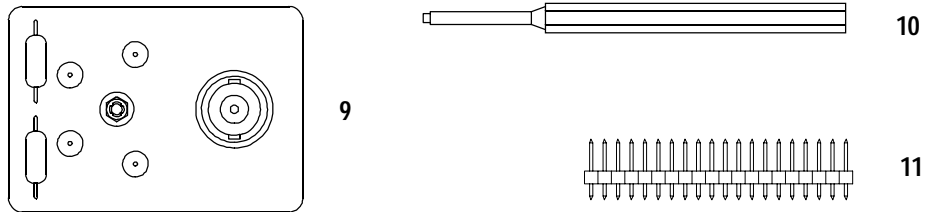


Figure 1-1



1153A Differential Probe and Accessories

Figure 1-2



1153A Miscellaneous Accessories

Accessories available

The following accessories are available for use with the 1153A:

- 10100C 50 Ω Feedthrough termination
- 5959-9335 Long Extension Lead (5.5 inch/14 cm), package of 5
- 5090-4356 SMT clip, package of 20
- 10467-68701 Micro Clip, package of 4



Performance specifications

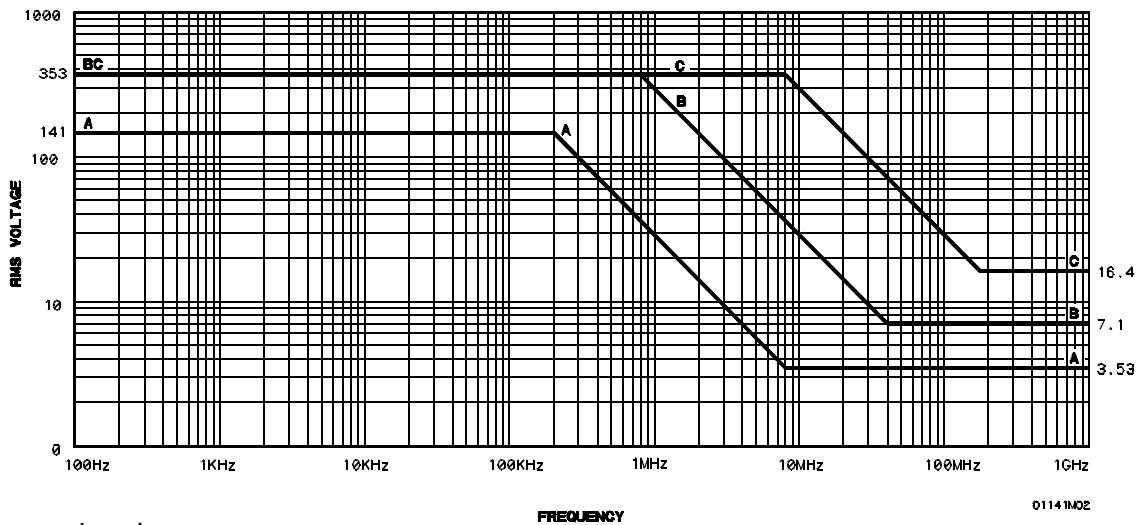
The following table gives performance specifications for the probe.

Table 1-2
Performance Specifications

Parameter	Probe alone	With 10:1 attenuator	With 100:1 attenuator
Bandwidth (-3 dB)	dc to 200 MHz ¹		
dc gain accuracy	2.0% with $50 \pm 0.1\Omega$ load	4.0% with $50 \pm 0.1\Omega$ load	
Maximum input voltage (see figure 1-3)	± 200 V(dc + peak ac), CAT I		
CMRR	See figure 1-4		

¹ For maximum signal fidelity above 100 MHz, limit the probe input (without attenuators) to ≤ 300 mV peak-to-peak

Figure 1-3

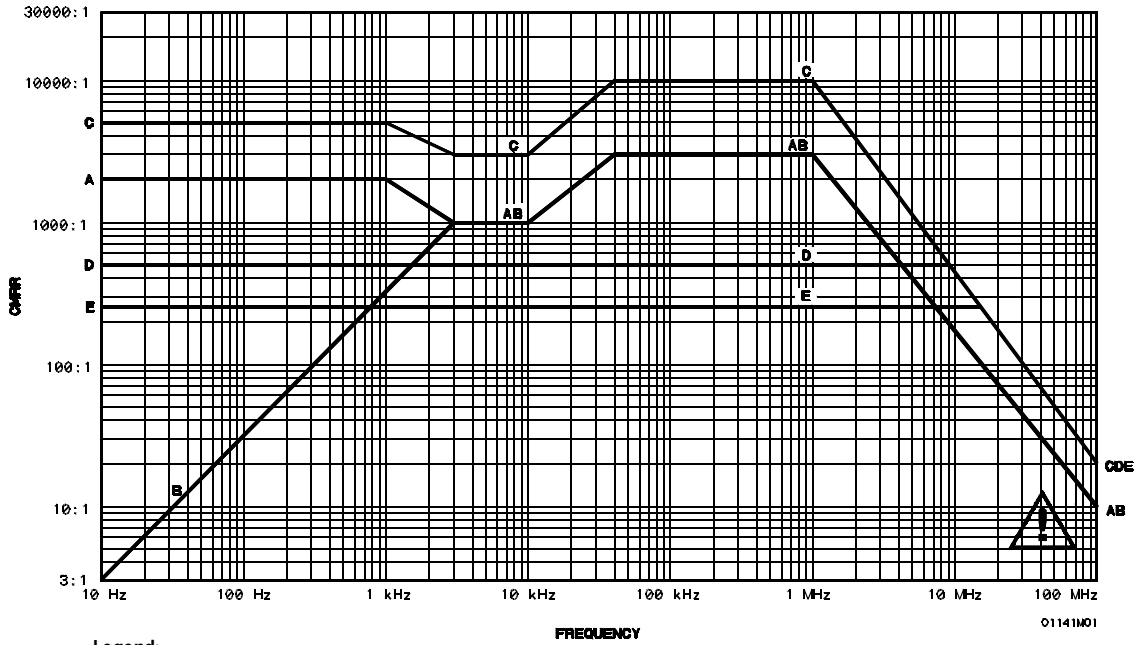


Legend:

- A. Input voltage limits for probe alone.
- B. Input voltage limits for 10:1 adapter.
- C. Input voltage limits for 100:1 adapter.

Maximum Input Voltage vs. Frequency

Figure 1-4



Legend:

- A. CMRR specification for probe with no input adapters.
- B. Low-frequency CMRR specification for probe with the ac adapter.
- C. Typical CMRR characteristic for differential probe with no input adapters.
- D. Typical CMRR characteristic for differential probe with 10:1 attenuator adapter at input.
- E. Typical CMRR characteristic for differential probe with 100:1 attenuator adapter at input.

CMRR Specifications and Characteristics



Performance characteristics

The following table gives performance characteristics for the probe.

Table 1-3
Performance Characteristics

Parameter	Probe alone	With 10:1 attenuator	With 100:1 attenuator
System bandwidth	200 MHz with 54800 family of oscilloscopes		
Rise Time	1.75 ns calculated from $t_r = (0.35/\text{bandwidth})$		
Linear differential input range			
DC mode with no offset	±300 mV peak	±3.0 V peak	±30 V peak
with Lf reject or appropriate offset	±18 Vdc, decreasing to ±300 mV at 30 Hz	±180 Vdc, decreasing to ±3.0 V at 30 Hz	±500 Vdc, decreasing to ±30 V at 30 Hz
Common-mode operating range			
dc	±18 V dc	±180 V dc	±500 V dc
dc to 30 Hz	linearly decreased to 30 Hz value		
30 Hz to 200 MHz	±0.5 V peak	±5 V peak	±50 V peak
dc offset range	±18 V	±180 V	±500 V
Input Impedance			
Resistance	1 MΩ	9 MΩ	10 MΩ
Capacitance	7 pF	3.5 pF	2 pF
ac coupling low-frequency¹ response (-3 dB)	15 Hz	1.5 Hz	1.5 Hz
Lf reject response	1.7 Hz (LFR1) and 0.14 Hz (LFR2)		
Output termination impedance	50Ω		
Display noise	≤500 μV _{rms}		
Overload recovery	<1 ms from overdrive that is less than the common mode range		

¹ With ac coupling adapter and input coupling set to dc.

General characteristics

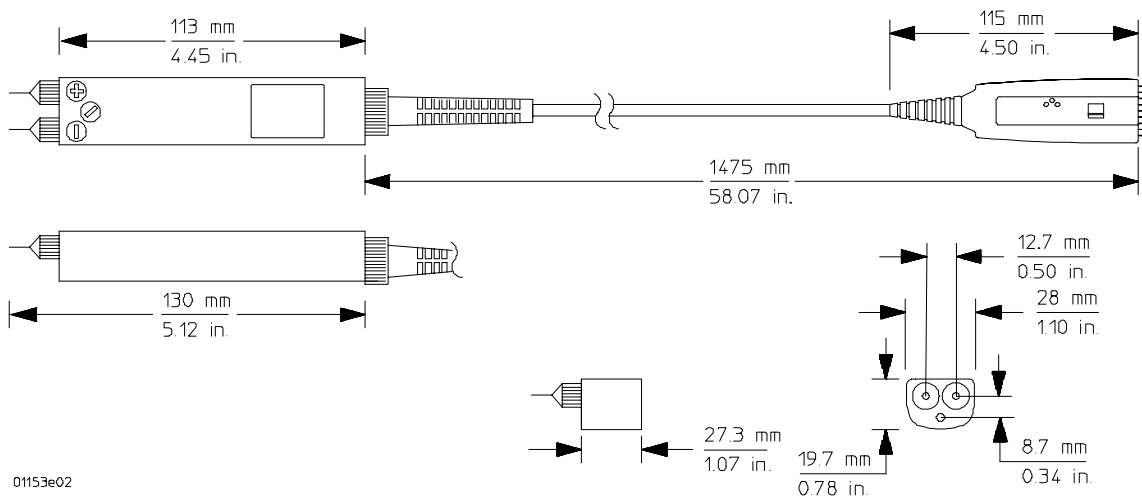
The following table gives general characteristics for the probe.

Table 1-4
General Characteristics

Environmental Conditions	Operating	Non-operating
Temperature	0 °C to +55 °C (32 °F to +131 °F)	–40 °C to +70 °C (–40 °F to +158 °F)
Humidity	up to 95% relative humidity (non-condensing) at +40 °C (+104 °F)	up to 90% relative humidity at +65 °C (+149 °F)
Altitude	up to 4,600 meters (15,000 ft)	up to 15,300 meters (50,000 ft)
Vibration	Random vibration 5 to 500 Hz, 10 minutes per axis, 0.3 g _{rms} .	Random vibration 5 to 500 Hz, 10 min. per axis, 2.41 g _{rms} . Resonant search 5 to 500 Hz swept sine, 1 octave/min. sweep rate, (0.75g), 5 min. resonant dwell at 4 resonances per axis.
Power Requirements	+12 Vdc @ 33 mA max –12 Vdc @ 16 mA max +6 Vdc @ 80 mA max –6 Vdc @ 130 mA max (voltages supplied from AutoProbe Interface)	
Weight	approximately 0.59 kg (1.3 lb)	
Dimensions	Refer to the outline drawing on next page.	

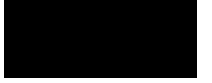


Figure 1-5



01153e02

1153A Differential Probe Dimensions



Operating the probe

Introduction

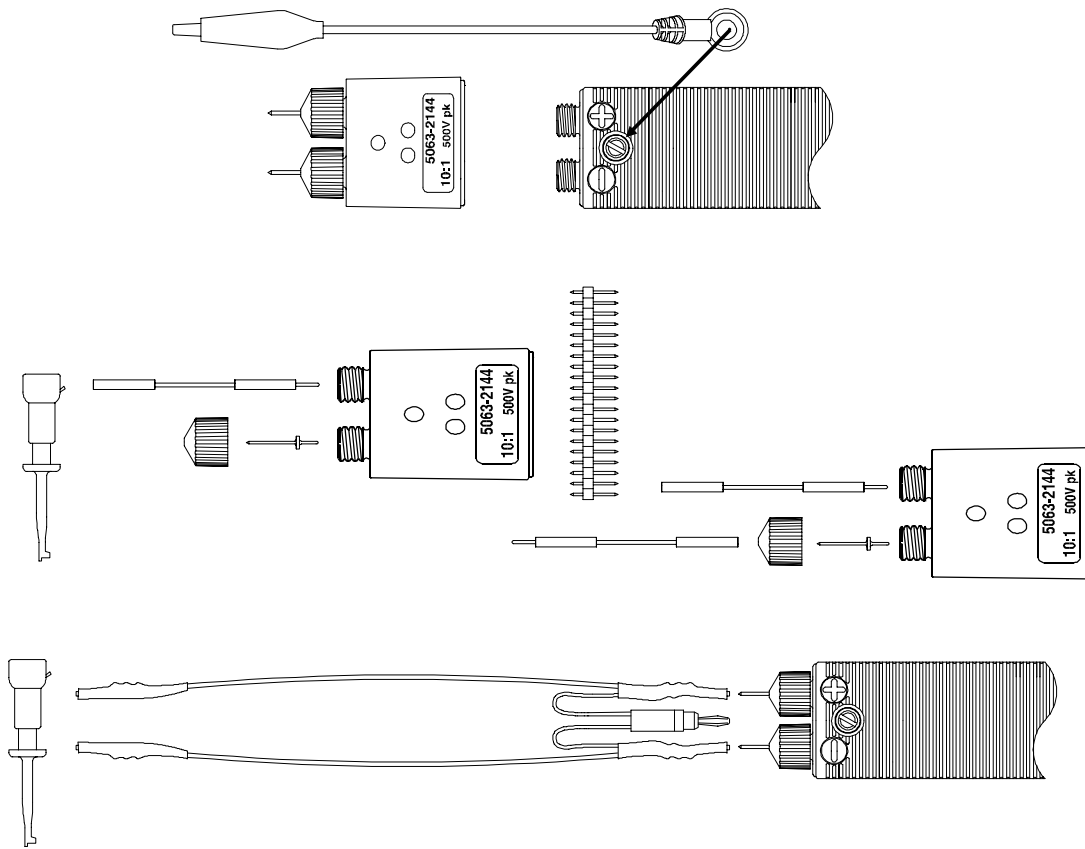
This section of the manual contains information and instructions for:

- Using accessories
- Grounding the probe
- Probe coupling
- Discussion of common mode rejection ratio (CMRR) and differential amplifiers

Using the accessories

The 1153A Differential Probe and accessories provide a variety of ways to connect to circuitry and make measurements. In the descriptions, any method used to connect to the probe signal inputs also applies to the adapters. The figure below shows, in a general way, the use of accessories.

Figure 2-6



Basic Accessory Connections

Probe tips

Probe tips fit into the receptacles in the probe and are held in place with probe tip caps.

If necessary, you can solder the probe tips into a circuit or wires can be soldered to the tips. If you solder to the probe tips, be careful not to melt the plastic probe tip caps.

Because of the close tolerances between the probe tip caps and probe tips, it will be difficult to separate the probe tips and caps once the probe tips have been soldered.

Ground lead

The circular end of the ground lead fits over the screw on the top side of the probe (see the previous figure).

Extension leads

The extension leads provide a flexible connection between circuitry and the probe.

- To provide a male connection to other circuitry, connect the extension lead over the probe tips.
- To provide a female connection, remove the probe tip caps and probe tips and connect the extension leads to the probe.

Use extension leads and similar connection accessories carefully. Extension leads compromise the high-frequency specifications of the probe. CMRR is particularly sensitive to unbalanced input parameters.

To prevent pickup of stray fields when you use extension leads, either the ones supplied with the 1153A or others, dress them carefully as follows:

- Connect the leads at right angles to the circuitry under test.
- Keep the leads as parallel as possible before they connect to the probe.

Mini clips

Mini clips and micro clips can be attached to the probe or adapter through the extension leads.

- 1** Remove the probe tip caps and tips.
- 2** Attach the extension leads to the probe or adapter.
- 3** Attach the mini or micro grabbers to the extension leads

Circuit connector posts

These 0.025-inch square posts can be used to connect either directly to the probe or to the extension leads.

Solder the posts directly into your circuitry or use them to make extension leads that plug into the inputs of the probe or adapters.

Shielded signal leads

The shielded signal leads allow connection to points in a circuit that are up to 10 inches apart. The leads are shielded to within approximately 1/2 inch of the end of the lead so they minimize pick-up due to stray fields from adjacent circuitry.

- 1** Connect the end with the ground connector to the probe pins and ground of the differential probe or adapter.
- 2** Connect the free ends of the leads to 0.025-inch square or 0.030-inch round pins in your circuitry or to the mini-grabbers.

Each lead has an input capacitance of approximately 15 pF. This capacitance may limit the bandwidth of your measurement (depending on the impedance of the circuit). Also, CMRR may be affected because of slight differences between the input capacitance of the two leads. CMRR is also affected by differences in impedance between the two measurement points.

Adapters

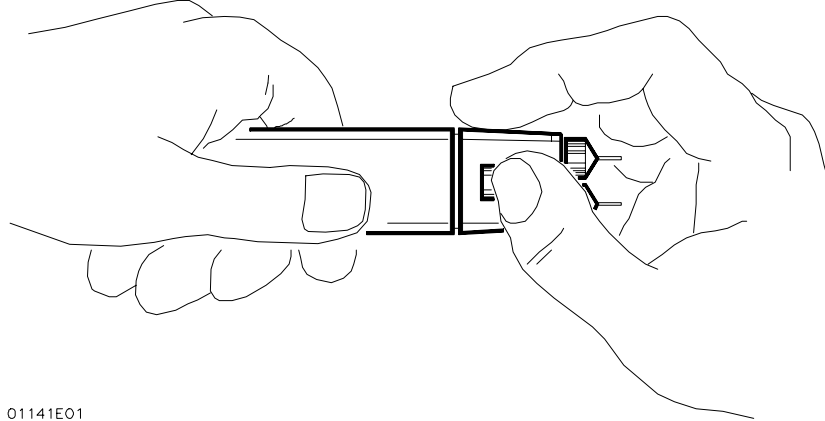
There are three adapters for use with the differential probe. Two adapters are attenuators, a 10:1 and a 100:1. The other is an ac adapter for blocking dc from the probe input.

The adapters are installed on the probe after the probe tip caps and probe tips have been removed. The adapter fastens to the probe using a thumbwheel located on the underside of the adapter. The figure below shows a good way to hold the probe while attaching the adapter.

- 1** Remove the probe tip caps, then probe tips, from the probe.
- 2** Fit the adapter over the end of the probe and rotate the thumbwheel with your finger until the adapter fits snugly.

A snug fit is important because the ground is maintained through the thumbwheel screw. A loosely attached adapter compromises the mechanical and electrical integrity of the combination.

Figure 2-7



01141E01

Attaching the adapters

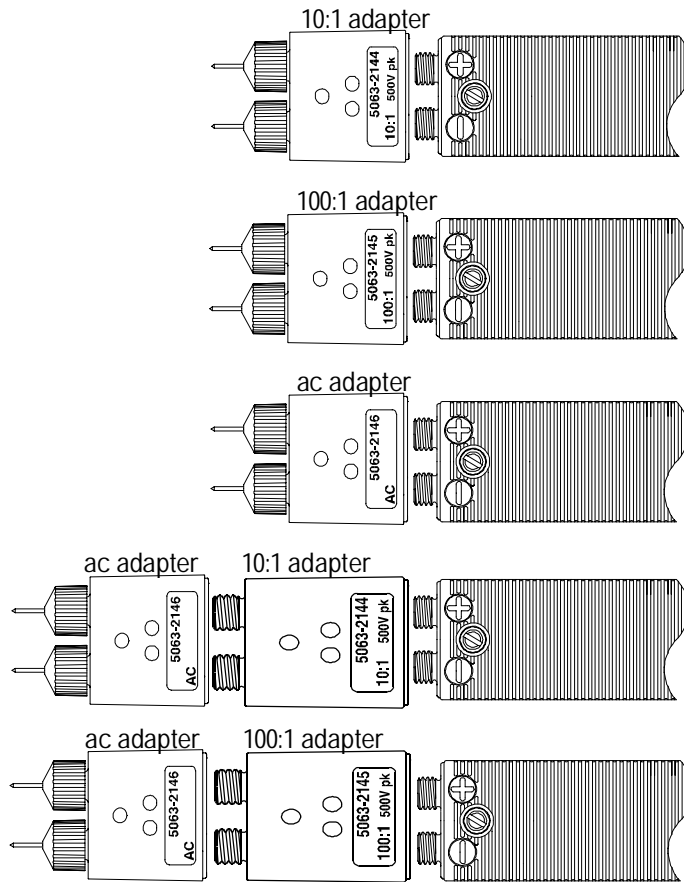
Adapter combinations

The figure below shows the allowed adapter and probe combinations. There are two specific combinations that should not be used.

- Do not attach the ac adapter between an attenuator adapter and the probe. An attenuator adapter must be terminated by the input resistance of the probe. The ac adapter isolates the probe input resistance.
- Do not cascade two attenuator adapters.

The attenuator adapters are designed to be terminated by the 1 MΩ resistance of the probe. The input resistance of the attenuator adapters is 9 MΩ for the 10:1 adapter and 10 MΩ for the 100:1 adapter.

Figure 2–8



Allowed adapter combinations

Grounding

Connector compatibility

The following are general connector characteristics for the probe, adapters, and accessories.

- The female connectors on the probe, adapters, and other accessories are designed to mate with 0.030-inch round or 0.025-inch square pins.
- The probe, adapter, and extension lead pins are 0.030-inch round.
- The strip of circuit connection posts provided as an accessory has 0.025-inch square pins.
- The mini-grabber has a 0.025-inch square pin.
- The ground connection at the end of the probe and adapters (where the adapters fasten) accepts an M3 metric screw.

Test board

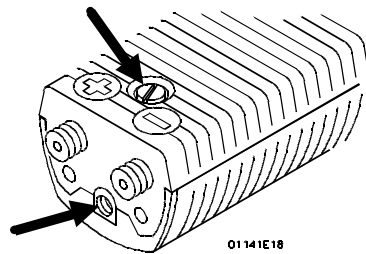
The primary use of the test board is to apply test and calibration signals to the inputs of the probe or adapters. Specific use of the test board is covered wherever it applies.

Grounding

Grounding is very important when probing circuitry. Improper grounding can increase the common mode signal level. This reduces the effectiveness of the differential probe.

The mechanical connections at the input of the probe are ground for probe signals. The screw where the ground lead attaches (see the figure below) fastens to this ground. Also, the attenuator and ac adapters fasten to this ground through the screw connection and the ground is carried through each adapter to its front.

Figure 2-9



Probe grounds

Coupling functions

There are three methods for blocking or compensating for the dc component of a signal. Each has specific advantages.

Table 2-1

Probe system coupling functions

	dc Offset	If Reject	ac Coupling Adapter
dc Blocked			
Probe alone	±18 V	±18 V	±200 V
Probe with 10:1	±180 V	±180 V	±500 V
Probe with 100:1	±500 V	±500 V	±500 V
Set-up needed	Adjust offset to put signal on screen	Select If Reject low-frequency corner	Attach ac Coupling adapter to differential probe
Remote Control?	Yes ¹	Yes ¹	No
CMRR degradation?	No	No	Yes
Low-frequency degradation?	No	Yes	Yes
¹ Isolated external dc reference and control signals are needed			

Lf Reject

Lf reject is the best method of eliminating the dc component of a signal when dc is not a factor in the measurement. Remove the ac adapter if it is installed.

- The key characteristics are:
- The low frequency component (from dc to the selected corner frequency) is automatically nulled by the lf reject circuitry.
- Probe CMRR specifications are not compromised as happens when the ac coupling adapter is used.
- There is a selectable low frequency corner with -3dB points at 1.7 Hz (LFR1) or 0.14 Hz (LFR2).
- The voltage reject range is ±18 V with the probe alone, ±180 V with the 10:1 attenuator, and ±500 V with the 100:1 attenuator.

Within the frequency and voltage characteristics noted elsewhere in this manual, low frequencies are nulled from the input signal.

Offset

Offset is the best method to use when the low-frequency corners associated with lf reject and the ac adapter interfere with the measurement. Remove the ac adapter if it is installed.

The key characteristics are:

- The user manually nulls the dc component with the offset adjustment.
- Offset is dc coupled so there is no low frequency rolloff.
- Probe CMRR specifications are not compromised as happens when the ac coupling adapter is used.
- The voltage offset range is ± 18 V with the probe alone, ± 180 V with the 10:1 attenuator, and ± 500 V with the 100:1 attenuator. (With the 100:1 attenuator, the offset range is restricted by the maximum input voltage rating rather than the operating range of the offset.)

Ac adapter

The ac adapter must be used when the dc component of the signal exceeds the operating range of the lf reject or offset methods. The ac adapter blocks the dc and low frequency component of the input by forming a high pass filter with the input impedance of the probe or adapter.

The key characteristics are:

- The ac adapter safely blocks ± 200 Vdc when attached directly to the probe or ± 500 Vdc when attached to a 10:1 or 100:1 adapter.
- The probe and adapters have different input impedances, so they have different low frequency corners with the ac adapter. When the ac adapter is directly on the probe the -3 dB corner is 15 Hz. When the ac adapter is on an attenuator the corner is 1.5 Hz.

The low-frequency CMRR when using the ac adapter is not as good as when using the probe alone or the probe with a 10:1 or 100:1 adapter.

CAUTION

If you measure a node having a high dc potential, the blocking capacitors in the ac adapter will charge to that potential. After making such measurements, discharge the capacitors by grounding both inputs of the ac adapter. This will prevent damage by a high voltage discharge into sensitive circuitry when the next measurement is made.

Differential amplifiers and CMRR

The 1153A Differential Probe is a high-impedance differential amplifier. A characteristic of differential amplifiers is the ability to reject signals that are common to the two inputs. The common mode rejection ratio (CMRR) is the measurement of this ability. It is expressed as the ratio between the amplitudes of the common mode and differential signals which produce equal outputs. For example, if a common mode signal of 1 V and a differential signal of 1 mV both produce outputs of 1 mV, the CMRR is 1000:1.

The ability to reject common mode signals is dependent on the balance designed into the differential amplifier. At higher frequencies it becomes harder to balance circuit parasitics and the parameters of devices so CMRR degrades as frequency increases. Also, stray coupling increases with frequency and coupling may vary between the two differential paths.

The CMRR of the 1153A Differential Probe is specified at the input of the probe and cannot be affected except by adjustments in the probe. However, the way the probe is connected into the circuitry being tested can have a big influence in the overall result of the measurement, especially at high frequencies.

The following things can affect the effective CMRR of a test setup.

The connection to the circuit under test The method used to connect the probe is important because it involves the symmetry of the differential input circuitry. For example, using different lengths of wire to connect the circuit to the two probe inputs unbalances the inductance and capacitance at the inputs. The effective CMRR will be reduced, especially at high frequencies. Additionally, coupling from adjacent circuitry will be less balanced.

The impedance of the source This is another instance where the symmetry of the differential circuit is important. The impedance of the source forms a network with the input impedance of the connection and the probe. This network determines the frequency response for the measurement. If each side of the differential source has a different impedance, the frequency response of each side will be different and the unbalance is reflected in a reduced CMRR. Of course, lower source impedances have less effect on the frequency response of the measurement.

The ground connection A poorly located ground connection allows ground loops to add to the common mode signal.

Frequency Frequency is the most important factor in CMRR only because all of the factors mentioned above are frequency dependent. The unbalances of capacitance and inductance are more important as frequency increases. Therefore, good high-frequency practice is important when using a high impedance differential probe.

On the other hand, if the differential probe is ac coupled to the circuit under test (the ac adapter is being used) the CMRR will be degraded below a certain frequency; the lower the frequency the worse the CMRR. This is because unbalance in the series capacitances of the ac coupler becomes more significant the lower the frequency.



Service

Introduction

This chapter provides service information for the 1153A Differential Probe. The following sections are included in this chapter:

- Service strategy
- Returning to Agilent Technologies for Service
- Troubleshooting
- Removing and replacing assemblies
- Replaceable parts

Safety

Read the Safety summary on the warranty pages at the back of this guide before servicing the instrument. Before performing any procedure, review it for cautions and warnings.

WARNING

Maintenance should be performed by trained service personnel aware of the hazards involved (for example, fire and electric shock). When maintenance can be performed without power applied, the power cord must be removed from the instrument.

Service Strategy

To return the 1153A Differential Probe to optimum performance requires factory repair. All probes must be returned to the factory for repair and calibration until January 1998. After that time, if the probe is under warranty, normal warranty services apply. If the probe is not under warranty, a failed probe can be exchanged for a reconditioned one at a nominal cost.

To return the probe to Agilent Technologies for service

Before shipping the instrument to Agilent Technologies, contact your nearest Agilent Technologies sales office for additional details.

1 Write the following information on a tag and attach it to the instrument.

- Name and address of owner
- Instrument model number
- Instrument serial number
- Description of the service required or failure indications

2 Remove all accessories from the instrument.

Accessories include all cables. Do not include accessories unless they are associated with the failure symptoms.

3 Protect the instrument by wrapping it in plastic or heavy paper.

4 Pack the instrument in foam or other shock absorbing material and place it in a strong shipping container.

You can use the original shipping materials or order materials from an Agilent Technologies Sales Office. If neither are available, place 3 to 4 inches of shock-absorbing material around the instrument and place it in a box that does not allow movement during shipping.

5 Seal the shipping container securely.

6 Mark the shipping container as FRAGILE.

In any correspondence, refer to instrument by model number and full serial number.

Probe troubleshooting

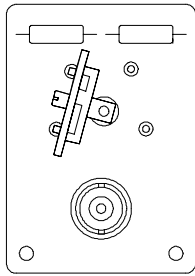
Use the following procedures to assist in troubleshooting problems with the 1153A Differential Probe.

Preparing the probe for troubleshooting

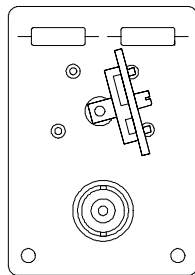
The probe bottom cover must be removed before troubleshooting to allow access to signals where the probe cable connects to the pc board.

- 1** Remove the probe tip caps and probe tips.
- 2** Loosen the probe clamp ring at the cable end of the probe (1/4 turn counter-clockwise) and slide it down the cable.
- 3** Remove the bottom cover.
 - a** At the cable end of the probe, separate the covers about one centimeter (1/2 inch).
 - b** Slide the bottom (curved) cover toward the cable end of the probe until the locator pins at the probe end of the bottom cover clear the holes. Then, remove the cover.

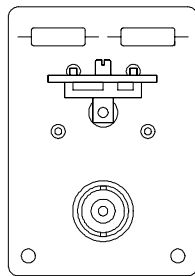
Troubleshooting the probe



Signal to + input



Signal to - input



Signal to both inputs

- 1 Connect the probe to the channel input of an Infiniium oscilloscope. This will supply power to the probe amplifier and correctly terminate the probe output.
- 2 Apply a known signal from a signal source to the coaxial connector on the test board using a coaxial cable.
- 3 Connect the probe to the test board in the position shown in the drawing on the upper left (signal to + input) and note the displayed output on the oscilloscope.
- 4 Check for an identical output at the solder connection where the probe cable attaches to the probe pc board.
If the probe output cable is unterminated, or the coax is open, the output signal will be about twice the amplitude of the input signal.
- 5 Repeat steps 3 and 4 with probe connected to the test board in the position shown in drawing on the middle left (signal to - input.)
If the probe output cable is unterminated, or the coax is open, the output signal will be about twice the amplitude of the input signal.
- 6 Connect the probe to the test board in the differential mode position shown in the drawing on the lower left (signal to both inputs.)
- 7 Check for zero output at the solder connection where the probe cable attaches to the probe pc board.
- 8 If any of the signals observed in step 3 through 7 are incorrect, check the power supply voltages from the Infiniium oscilloscope. Refer to "To check probe power outputs" in the Troubleshooting chapter of the service guide for the Infiniium oscilloscope.
- 9 If these power supply voltages from the Infiniium oscilloscope are correct, repair the probe by replacing the probe pc assembly A1 (refer to table 3-1, Replaceable Parts.)
- 10 If the output at the solder connection where the probe cable attaches to the probe pc board is correct but the output to the Infiniium oscilloscope is not correct, repair the probe by replacing the probe cable assembly W1 (refer to table 3-1, Replaceable Parts.)

Removing and replacing assemblies

This section contains procedures for the removal and replacement of major assemblies.

CAUTION

Never remove or install any assembly with the instrument power ON. Component damage can occur.

Differential probe

Use the following procedure to remove and replace the amplifier PC board in the differential probe.

CAUTION

ELECTROSTATIC DISCHARGE can damage electronic components. Use grounded wriststraps and mats when servicing the probe.

CAUTION

Handle the differential probe carefully once it has been disassembled. If unsupported, the weight of the cable can put strain on the PC board.

Disassemble Probe

- 1** Remove the probe tip caps and probe tips.
- 2** Loosen the probe clamp ring at the cable end of the probe (1/4 turn counter-clockwise) and slide it down the cable.
- 3** Remove the bottom cover.
 - a** At the cable end of the probe, separate the covers about one centimeter (1/2 inch).
 - b** Slide the bottom cover toward the cable end of the probe until the locator pins at the probe input clear the holes. Then, remove the cover.

Note the way the cable strain relief is keyed and held at the rear of the top cover.

4 Remove the probe top cover.

The ground screw passes through the top cover and PC board and screws into the ground block.

a Remove the ground screw on the top of the probe.

At the cable end, the PC board fits over pins in the top cover.

b Lift the board off of the pins and slide it in the direction of the cable until the input connectors clear the front of the probe.

5 Unsolder the two connections where the coaxial output cable connects to the PC board.

6 Disconnect the cable connector from the probe PC board.

Reassemble probe

Reassembly is essentially the reverse of the disassembly procedure.

1 If replacing the PC board, remove the input connectors from the old board and put them on the new one.

2 If replacing the cable, note the orientation of the probe clamp ring on the old cable, remove the ring and put it on the new cable.

3 Connect the cable connector to the PC board.

4 Solder the two connections of the coaxial cable to the PC board.

On a new probe cable, the conductors of the coaxial cable are connected by a heavy single wire. Cut the heavy wire so it matches the wire on the cable that was removed.

5 Assemble the PC assembly into the top cover.

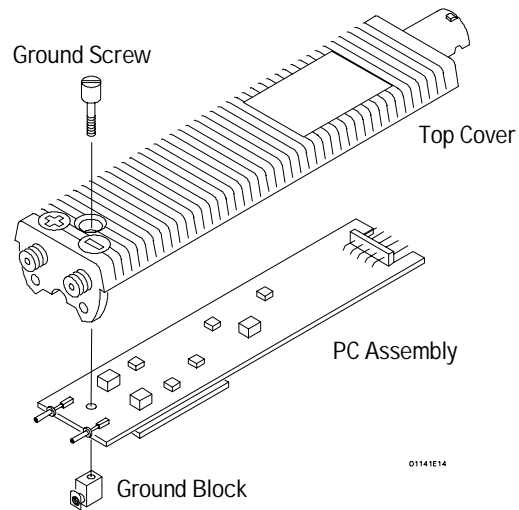
The large hybrid is exposed when the assembly is in the top cover. The figure on the next page shows the sequence of the ground screw, top cover, PC board, and ground block.

a Insert the input connectors first, and seat the cable end of the PC assembly over the pins at the rear of the cover.

b Position the ground block at the front of the PC assembly.



Figure 3–10



Reassembling the probe

- c Insert the grounding screw through the top cover and screw it into the ground block as shown in the figure.
- 6 Replace the bottom cover.
 - a Position the cable strain relief and with one hand, hold the cable and top cover together.
The flange on the strain relief has a notch that fits over a protrusion in the top cover.

CAUTION

Note where the two pins at the rear of the top cover enter the holes in the PC assembly. Position the cable wires away from these two areas. When the bottom cover is closed, part of it will pinch wires that are laying over these areas.

- b Insert the pins at the front of the bottom cover into the holes at the front of the top cover.
- c Close the covers together and fasten with the probe clamp ring. If the covers do not fit together tightly and easily, check for pinched wires (see caution above).

Probe adapters

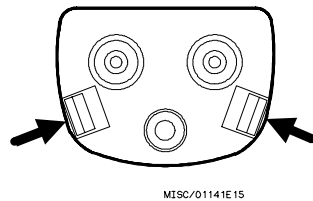
Use the following procedure to disassemble the probe adapters. The adapter housing consists of two plastic parts, one of which slides into the other. The parts are held together by the spring effect of two plastic tabs on the inner part.

Mechanically, the ac adapter is similar to the 10:1 and 100:1 attenuator adapters. The attenuator adapters have an extra ground connector which connects the substrate ground to the thumbwheel screw and plating inside the housing.

Disassemble Adapter

- 1 Remove the probe tip caps and the probe tips from the adapter input.
- 2 Hold the adapter in one hand, taking care not to block the output end of the adapter (the end which attaches to the probe).

Figure 3-11



Disassembling adapters

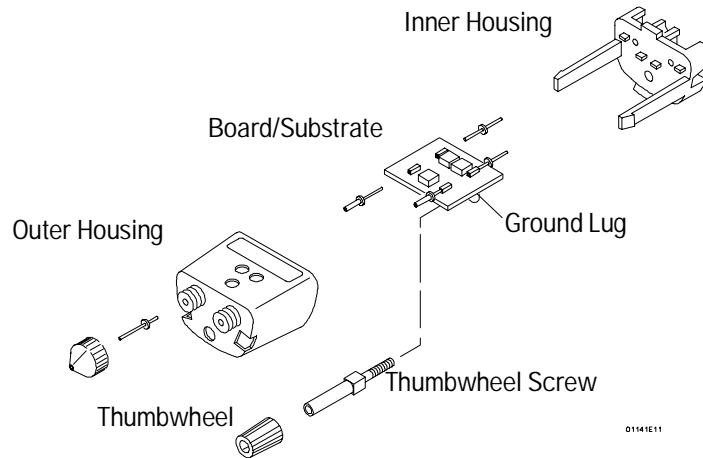
- 3 Note the view of the input end of the adapter in the accompanying figure. The arrows indicate the holding tabs.
- 4 With the thumb and forefinger, squeeze the tabs together, as indicated by the arrows. Simultaneously, push the tabs into the outer housing so the inner housing begins to slide out.
- 5 While holding the outer housing, push back against the thumbwheel until the inner housing can be grasped and removed.

Reassemble Adapter

Reassembling the adapter is slightly harder because you have to align the connector pins and thumbwheel screw, while sliding the inner housing and outer housing together.

- 1 Be sure the input connectors and output pins are present and seated on the substrate or PC board.

Figure 3-12



Reassembling the adapter

- 2 Combine the thumbwheel screw and thumbwheel and insert them into the hole in the outer housing.
- 3 Insert the substrate/board into the outer housing. Slip the attenuator ground (attenuator adapters only) over the thumbwheel screw and seat the input connectors in the proper holes in the housing.
Do not force reassembly of the adapter. The housing halves will slide together with moderate friction.
- 4 Align the inner housing tabs with the grooves in the side of the outer housing and slide the two parts together.
While seating the thumbwheel screw and pins, it will help to hold the assembly vertical, with the input end of the adapter down. This will allow the assemblies to sit vertical and more easily align with the holes in the inner housing.
- 5 Seat the thumbwheel screw first, then the output pins, into the appropriate holes in the inner housing.
- 6 Once the two housings are nearly together, press them together firmly until the tabs click into place.

Replaceable parts

This section contains information for ordering parts. Service support for the 1153A Differential Probe is to the assembly level. Service support for the adapters is as complete assemblies, except for the probe tip caps and the probe tips.

Ordering replaceable parts

Listed parts

To order a part in the material list, quote the Agilent part number, indicate the quantity desired, and address the order to the nearest Agilent Technologies Sales Office.

Unlisted parts

To order a part not listed in the material list, include the instrument part number, instrument serial number, a description of the part (including its function), and the number of parts required. Address the order to the nearest Agilent Technologies Service Center.

Direct Mail Order System

Within the USA, Agilent Technologies can supply parts through a direct mail order system. There are several advantages to this system:

- Direct ordering and shipment from the Agilent Technologies parts center in California, USA.
- No maximum or minimum on any mail order (there is a minimum amount for parts ordered through a local Agilent Technologies Sales Office when the orders require billing and invoicing).
- Prepaid transportation (there is a small handling charge for each order).
- No invoices.
- In order for Agilent Technologies to provide these advantages, a check or money order must accompany each order.

- Mail order forms and specific ordering information are available through your local Agilent Technologies office. Addresses and telephone numbers are located in a separate document shipped with the manuals.

Exchange Assemblies

The pc assembly used in this probe has been set up for an exchange program. This program allows the customer to exchange a faulty assembly with one that has been repaired, calibrated, and performance-verified by the factory. The cost is significantly less than that of a new part. The exchange parts have a part number in the form xxxxx-695xx.

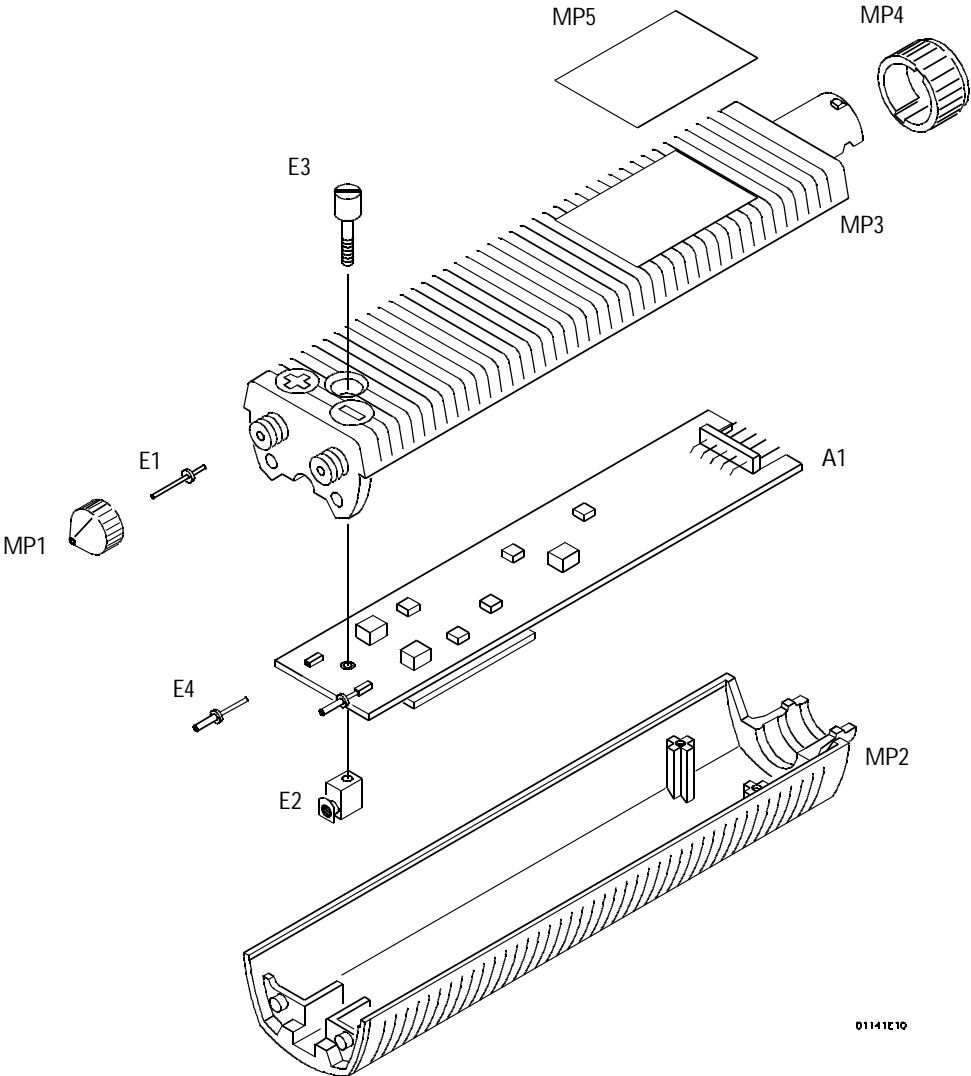
After receiving the repaired exchange part from Agilent Technologies, a United States customer has 30 days to return the faulty assembly. For orders not originating in the United States, contact the local Agilent Technologies service organization. If the faulty assembly is not returned within the warranty time limit, the customer will be charged an additional amount. The additional amount will be the difference in price between a new assembly and that of an exchange assembly.

Replaceable parts

Table 3-1 is a list of replaceable parts, to the assembly level, for the probe. Table 3-2 is a list of replaceable parts for the adapters. The information given for each part consists of the following:

- Reference designator.
- Agilent part number.
- Total quantity (Qty) in instrument or on assembly. The total quantity is given once and at the first appearance of the part number in the list.
- Description of the part.

Figure 3-13



01141E10

1153A Differential Probe Parts

Service
Removing and replacing assemblies

Table 3-1

1153A Replaceable Parts			
Reference Designator	Part Number	Qty	Description
A1	01141-69501		Exchange PC Assembly-Differential Probe
A1	01141-66501	1	PC Assembly-Differential Probe
E1	01141-26102	2	Probing Pin
E2	01141-22301	1	Ground Block
E3	01141-22401	1	Ground Screw
E4	01141-26101	2	Input Connector
MP1	01141-24102	2	Cap-probing Pin
MP2	01141-44702	1	Probe Bottom Cover
MP3	01141-44102	1	Probe Top Cover
MP4	01141-22502	1	Probe Pod Clamp Ring
MP5	01153-94301	1	Differential Probe Label
W1	01153-61602	1	Probe Cable Assembly

Table 3-2

Adapter Replaceable Parts		
Part Number	Qty	Description
10:1 Attenuator Adapter		
01141-26102	2	Probing Pin
01141-24102	2	Cap-probing Pin
100:1 Attenuator Adapter		
01141-26102	2	Probing Pin
01141-24102	2	Cap-probing Pin
AC Adapter		
01141-26102	2	Probing Pin
01141-24102	2	Cap-probing Pin

Index

A

ac adapter, 2-10
ac coupling lf response, 1-9
accessories, 2-3 to 2-7
 adapters, 2-6
 available to order, 1-6
 circuit connector posts, 2-5
 extension leads, 2-4
 ground lead, 2-4
 mini clips, 2-5
 probe tips, 2-4
 shielded signal leads, 2-5
 supplied with probe, 1-4 to 1-5
 test board, 2-8
adapter, 2-6
 100:1, 2-6
 10:1, 2-6
 ac, 2-10
 combinations, 2-7
altitude range, 1-10

B

bandwidth, 1-7, 1-9

C

characteristics
 general, 1-10 to 1-11
 performance, 1-9
circuit connector posts, 2-5
cleaning, 1-3
cmrr, 1-7 to 1-8, 2-11 to 2-12
common mode rejection ratio, 2-11 to 2-12
common-mode operating range, 1-9
connector compatibility, 2-8
coupling functions, 2-9 to 2-10

D

dc gain accuracy, 1-7
dc offset range, 1-9
differential amplifiers, 2-11 to 2-12
dimensions, 1-10 to 1-11
direct mail order system, 3-11
displayed noise, 1-9

E

environmental, 1-10
 altitude, 1-10
 humidity, 1-10
 temperature, 1-10
 vibration, 1-10
exchange assemblies, 3-12
extension leads, 2-4

G

general characteristics, 1-10 to 1-11
ground lead, 2-4
grounding, 2-8

H

humidity range, 1-10

I

input impedance, 1-9
input voltage, 1-7
inspecting, 1-3

L

lf reject, 2-9
linear differential input range, 1-9

M

maximum input voltage, 1-7
maximum input voltage vs frequency, 1-7
mini clips, 2-5

N

noise, displayed, 1-9

O

offset, 2-10
output termination impedance, 1-9
overload recovery, 1-9

P

packing for return, 3-3
performance characteristics, 1-9
performance specifications, 1-7 to 1-8
power requirements, 1-10
probe tips, 2-4

R

removing and replacing, 3-6
 differential probe, 3-6
 probe adapters, 3-9
replaceable parts, 3-11
 direct mail order system, 3-11
 exchange assemblies, 3-12
 ordering, 3-11
returning probe to Agilent Technologies,
 3-3
rise time, 1-9

S

service strategy, 3-2
shielded signal leads, 2-5
specifications, 1-7 to 1-8
system bandwidth, 1-9

T

temperature range, 1-10
test board, 2-8
troubleshooting, 3-4

V

vibration range, 1-10

W

weight, 1-10

DECLARATION OF CONFORMITY

according to ISO/IEC Guide 22 and EN 45014

Manufacturer's Name: Agilent Technologies
Manufacturer's Address: Colorado Springs Division
1900 Garden of the Gods Road
Colorado Springs, CO 80907 USA

declares, that the product

Product Name: Oscilloscope probe
Model Number(s): 1153A
Product Option(s): All

conforms to the following Product Specifications:

Safety: IEC 1010-1:1990+A1 / EN 61010-1:1993
UL 3111
CSA-C22.2 No. 1010.1:1993

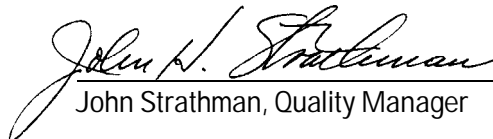
EMC: CISPR 11:1990 / EN 55011:1991 Group 1 Class A
IEC 555-2:1982 + A1:1985 / EN 60555-2:1987
IEC 555-3:1982 + A1:1990 / EN 60555-3:1987 + A1:1991
IEC 801-2:1991 / EN 50082-1:1992 4 kV CD, 8 kV AD
IEC 801-3:1984 / EN 50082-1:1992 3 V/m, {1kHz 80% AM, 27-1000 MHz}
IEC 801-4:1988 / EN 50082-1:1992 0.5 kV Sig. Lines, 1 kV Power Lines

Supplementary Information:

The product herewith complies with the requirements of the Low Voltage Directive 73/23/EEC and the EMC Directive 89/336/EEC and carries the CE marking accordingly.

This product was tested in a typical configuration with Agilent Technologies test systems.

Colorado Springs, 04/22/97


John Strathman, Quality Manager

European Contact: Your local Agilent Technologies Sales and Service Office or Agilent Technologies GmbH, Department ZQ / Standards Europe, Herrenberger Strasse 130, D-71034 Böblingen Germany (FAX: +49-7031-14-3143)

Product Regulations

Safety IEC 1010-1:1990+A1 / EN 61010-1:1993
UL 3111
CSA-C22.2 No.1010.1:1993

EMC This Product meets the requirement of the European Communities (EC)
EMC Directive 89/336/EEC.



Emissions EN55011/CISPR 11 (ISM, Group 1, Class A equipment)



Immunity	EN50082-1	Code ¹	Notes ²
	IEC 555-2	1	
	IEC 555-3	1	
	IEC 801-2 (ESD) 4kV CD, 8kV AD	2	
	IEC 801-3 (Rad.) 3 V/m	2	
	IEC 801-4 (EFT) 0.5 kV, 1kV	2	

¹ Performance Codes:

- 1 PASS - Normal operation, no effect.
- 2 PASS - Temporary degradation, self recoverable.
- 3 PASS - Temporary degradation, operator intervention required.
- 4 FAIL - Not recoverable, component damage.

² Notes: (none)

Sound Pressure Level N/A

© Copyright Agilent Technologies 1997-2000
All Rights Reserved.

Reproduction, adaptation, or translation without prior written permission is prohibited, except as allowed under the copyright laws.

Restricted Rights Legend.

Use, duplication or disclosure by the U.S. Government is subject to restrictions as set forth in subparagraph (c) (1) (ii) of the Rights in Technical Data and Computer Software clause at DFARS 252.227-7013 for DOD agencies, and subparagraphs (c) (1) and (c) (2) of the Commercial Computer Software Restricted Rights clause at FAR 52.227-19 for other agencies.

Agilent Technologies
3000 Hanover Street
Palo Alto, California 94304
U.S.A.

Document Warranty

The information contained in this document is subject to change without notice.

Agilent Technologies makes no warranty of any kind with regard to this material, including, but not limited to, the implied warranties of merchantability or fitness for a particular purpose.

Agilent Technologies shall not be liable for errors contained herein or for damages in connection with the furnishing, performance, or use of this material.

Safety

This apparatus has been designed and tested in accordance with IEC Publication 1010, Safety Requirements for Measuring Apparatus, and has been supplied in a safe condition. In addition, note the external markings on the instrument that are described under "Safety Symbols."

Safety Symbols



Instruction manual symbol: the product is marked with this symbol when it is necessary for you to refer to the instruction manual in order to protect against damage to the product.



Hazardous voltage symbol.



Earth terminal symbol: Used to indicate a circuit common connected to grounded chassis.

WARNING

The Warning sign denotes a hazard. It calls attention to a procedure, practice, or the like, which, if not correctly performed or adhered to, could result in personal injury. Do not proceed beyond a Warning sign until the indicated conditions are fully understood and met.

CAUTION

The Caution sign denotes a hazard. It calls attention to an operating procedure, practice, or the like, which, if not correctly performed or adhered to, could result in damage to or destruction of part or all of the product. Do not proceed beyond a Caution symbol until the indicated conditions are fully understood or met.

Product Warranty

This Agilent Technologies product has a warranty against defects in material and workmanship for a period of three years from date of shipment. During the warranty period, Agilent Technologies will, at its option, either repair or replace products that prove to be defective.

For warranty service or repair, this product must be returned to a service facility designated by Agilent Technologies.

For products returned to Agilent Technologies for warranty service, the Buyer shall prepay shipping charges to Agilent Technologies and Agilent Technologies shall pay shipping charges to return the product to the Buyer. However, the Buyer shall pay all shipping charges, duties, and taxes for products returned to Agilent Technologies from another country.

Agilent Technologies warrants that its software and firmware designated by Agilent Technologies for use with an instrument will execute its programming instructions when properly installed on that instrument. Agilent Technologies does not warrant that the operation of the instrument software, or firmware will be uninterrupted or error free.

Limitation of Warranty

The foregoing warranty shall not apply to defects resulting from improper or inadequate maintenance by the Buyer, Buyer-supplied software or interfacing, unauthorized modification or misuse, operation outside of the environmental specifications for the product, or improper site preparation or maintenance.

No other warranty is expressed or implied. Agilent Technologies specifically disclaims the implied warranties of merchantability or fitness for a particular purpose.

Exclusive Remedies

The remedies provided herein are the buyer's sole and exclusive remedies. Agilent Technologies shall not be liable for any direct, indirect, special, incidental, or consequential damages, whether based on contract, tort, or any other legal theory.

Assistance

Product maintenance agreements and other customer assistance agreements are available for Agilent Technologies products.

For any assistance, contact your nearest Agilent Technologies Sales Office.

Certification

Agilent Technologies certifies that this product met its published specifications at the time of shipment from the factory. Agilent Technologies further certifies that its calibration measurements are traceable to the United States National Institute of Standards and Technology, to the extent allowed by the Institute's calibration facility, and to the calibration facilities of other International Standards Organization members.

About this edition

This is the *1153A Differential Probe User and Service Guide*.

Publication number
01153-97002, March 2000
Printed in USA.

Print history is as follows:
01153-97000, August 1997
01153-97001, January 2000
01153-97002, March 2000

New editions are complete revisions of the manual. Many product updates do not require manual changes; and, conversely, manual corrections may be done without accompanying product changes. Therefore, do not expect a one-to-one correspondence between product updates and manual updates.