

---

**Service  
Manual**

**Model 760401/760503  
WT210/WT230 Digital  
Power Meter**

SM 760401-01E

---

---

## Important Notice to the User

This manual contains information for servicing the YOKOGAWA's WT210/WT230 Digital Power Meter. Check the serial number to confirm that this is the correct service manual for the instrument to be serviced. *Do not use the wrong manual.*

Before any maintenance and servicing, *read all safety precautions carefully.*

*Only properly trained personnel* may carry out the maintenance and servicing described in this service manual.

*Do not disassemble the instrument or its parts*, unless otherwise clearly permitted by this service manual.

*Do not replace any part or assembly*, unless otherwise clearly permitted by this service manual.

In principle, Yokogawa Electric Corporation (YOKOGAWA) does not supply parts other than those listed in the customer maintenance parts list in this service manual (mainly *modules* and *assemblies*). Therefore if an assembly fails, the user should replace the whole assembly and *not* components within the assembly (see "Note"). If the user attempts to repair the instrument by replacing individual components within the assembly, YOKOGAWA assumes no responsibility for any consequences such as defects in instrument accuracy, functionality, reliability, or user safety hazards.

YOKOGAWA does not offer more detailed maintenance and service information than that contained in this service manual.

All reasonable efforts have been made to assure the accuracy of the content of this service manual. However, there may still be errors such as clerical errors or omissions. YOKOGAWA assumes no responsibility of any kind concerning the accuracy or contents of this service manual, nor for the consequences of any errors.

All rights reserved. No part of this service manual may be reproduced in any form or by any means without the express written prior permission of YOKOGAWA. The contents of this manual are subject to change without notice.

### **Note**

---

YOKOGAWA instruments have been designed in a way that the replacement of electronic parts can be done on an assembly (module) basis by the user. YOKOGAWA instruments have also been designed in a way that troubleshooting and replacement of any faulty assembly can be done easily and quickly. Therefore, YOKOGAWA strongly recommends replacing the entire assembly over replacing parts or components within the assembly. The reasons are as follows:

- Repair of components can only be performed by specially trained and qualified maintenance personnel with special tools. In addition, repair of components requires various special parts and components, including costly ones. It also requires facilities where highly-accurate and expensive maintenance equipment and special tools are provided.
  - When taking the service life and cost of the instruments into consideration, the replacement of assemblies offers the user the possibility to use YOKOGAWA instruments more effectively and economically with a minimum in downtime.
- 

- Adobe and Acrobat are trademarks of Adobe System incorporated.

---

## Revisions

1st Edition: August 2002  
2nd Edition: September 2002  
3rd Edition: January 2003

## Safety Precautions

The following general safety precautions must be observed during all phases of operation, service, and repair of this instrument. Failure to comply with these precautions or with specific WARNINGS given elsewhere in this manual violates safety standards of design, manufacture, and intended use of the instrument.

Yokogawa Electric Corporation assumes no liability for the customer's failure to comply with these requirements.

---

### **WARNING**

This Service Manual is to be used by properly trained personnel only. To avoid personal injury, do not perform any servicing unless you are qualified to do so. Refer to the Safety Precautions prior to performing any service. Even in case of servicing according to this Service Manual and carried out by qualified personnel, YOKOGAWA assumes no responsibility for any result occurring from this servicing.

#### **Use the Correct Power Supply**

Ensure the source voltage matches the voltage of the power supply before turning ON the power.

#### **Use the Correct Power Cord and Plug**

To prevent an electric shock or fire, be sure to use the power supply cord supplied by YOKOGAWA. The main power plug must be plugged in an outlet with a protective grounding terminal. Do not invalidate protection by using an extension cord without protective grounding.

#### **Connect the Protective Grounding Terminal**

The protective grounding terminal must be connected to ground to prevent an electric shock before turning ON the power.

#### **Do Not Impair the of Protective Grounding**

Never cut off the internal or external protective grounding wire or disconnect the wiring of the protective grounding terminal. Doing so creates a potential shock hazard.

#### **Do Not Operate with Defective Protective Grounding or Fuse**

Do not operate the instrument if you suspect the protective grounding or fuse might be defective.

#### **Use the Correct Fuse**

To prevent fire, make sure to use a fuse of the specified rating for current, voltage, and type. Before replacing the fuses, turn OFF the power and disconnect the power source. Do not use a different fuse or short-circuit the fuse holder.

### Do Not Operate Near Flammable Materials

Do not operate the instrument in the presence of flammable liquids or vapors. Operation of any electrical instrument in such an environment constitutes a safety hazard.

### Do Not Remove Any Covers

There are some areas components inside the instrument containing high voltage. Do not remove any cover, if the power supply is connected. The cover should be removed by qualified personnel only.

### Ground the Instrument before Making External Connections

Connect the protective grounding before connecting the instrument to a measurement or control unit.

---

## Safety Symbols Used on Equipment and in Manuals



Danger. Refer to corresponding location on the instrument. This symbol appears on dangerous locations on the instrument which require special instructions for proper handling or use. The same symbol appears in the corresponding place in the manual to identify those instructions.

### WARNING

Calls attention to actions or conditions that could cause serious injury or death to the user, and precautions that can be taken to prevent such occurrences.

### CAUTION

Calls attention to actions or conditions that could cause light injury to the user or damage to the instrument or user's data, and precautions that can be taken to prevent such occurrences.

### Note

Provides important information for the proper operation of the instrument.

## Digital Numbers and Characters

Because the WT210/WT230 uses a 7-segment LED display, numbers, alphabets, and operation symbols are represented using special characters as follows. Some of the characters are not used.

0 → 0	A → A	K → k	U → u	^ (Exponent) → ^
1 → 1	B → b	L → L	V → v	
2 → 2	C → C Small c → c	M → m	W → w	
3 → 3	D → d	N → n	X → x	
4 → 4	E → E	O → o	Y → y	
5 → 5	F → F	P → p	Z → z	
6 → 6	G → G	Q → q	+ → +	
7 → 7	H → H Small h → h	R → r	- → -	
8 → 8	I → i	S → s	× → ×	
9 → 9	J → j	T → t	÷ → ÷	

## Key Lock

Please release the key lock before performing the tests in this manual. Key lock is engaged when the KEY LOCK indicator on the front panel is lit. To release the key lock, press the **SHIFT** key, followed by the **LOCAL** key. This will activate all keys for further operations. For details, see section 12.4 of the user's manual (IM 760401-01E).

---

# Overview of This Manual

This manual is meant to be used by qualified personnel only. Make sure to have read the safety precautions at the beginning of this manual and the warnings/cautions contained in the referred chapter prior to carrying out any servicing.

This manual contains the following chapters:

**1 Principles of Operation**

Describes the introduction and safety considerations.

**2 Performance Testing**

Describes the performance tests for checking performance of the instrument.

**3 Adjustments**

Describes the adjustments which can be adjusted by users.

**4 Troubleshooting**

Describes procedures for troubleshooting and how to handle in case parts need to be replaced.

**5 Schematic Diagram**

Describes the system configuration diagram.

**6 Customer Maintenance Parts List**

Contains exploded views and a list of replaceable parts.

**7 Procedures for Disassembly**

List the steps required to remove parts from the instrument.

Specifications are not included in this manual. For specifications, refer to IM 760401-01E.

# Contents

Important Notice to the User .....	i
Revisions .....	ii
Safety Precautions .....	ii
Safety Symbols Used on Equipment and in Manuals .....	iii
Overview of This Manual .....	iv
<b>Chapter 1 Principles of Operation</b>	
1.1 Introduction and Safety considerations .....	1-1
1.2 System Configuration and Block Diagram .....	1-2
<b>Chapter 2 Performance Testing</b>	
2.1 List of Tests and Testing Environment .....	2-1
2.2 List of Connection Diagrams .....	2-2
2.3 Testing Procedures .....	2-5
<b>Chapter 3 Adjustments</b>	
3.1 Operating Environment and Adjustment Equipment .....	3-1
3.2 Items and Circuits to be Adjusted .....	3-2
3.3 Entering Adjustment Mode .....	3-4
3.4 Adjustment Procedure .....	3-5
3.5 Communications Commands .....	3-9
<b>Chapter 4 Troubleshooting</b>	
4.1 Flow Chart .....	4-1
4.2 Confirming Results .....	4-4
<b>Chapter 5 Schematic Diagram</b>	
5.1 Schematic Diagram .....	5-1
<b>Chapter 6 Customer Maintenance Parts List</b>	
6.1 WT210 Customer Maintenance Parts List .....	6-1
6.2 WT210 Standard Accessories .....	6-4
6.3 WT230 Customer Maintenance Parts List .....	6-5
6.4 WT230 Standard Accessories .....	6-8
<b>Chapter 7 Procedures for Disassembly</b>	
7.1 Disassembling the WT210 .....	7-1
7.2 Disassembling the WT230 .....	7-8

1

2

3

4

5

6

7

# 1.1 Introduction and Safety considerations

## Introduction

This manual describes servicing information for any YOKOGAWA WT210/WT230 Digital Power Meter. This chapter contains information required for using this manual and information that must be read before starting servicing WT210/WT230 instruments.

## Safety Considerations

You must thoroughly read the safety precautions at the beginning of this manual. Also fully read the warnings and cautions contained in each chapter.

# 1.2 System Configuration and Block Diagram

## System Configuration

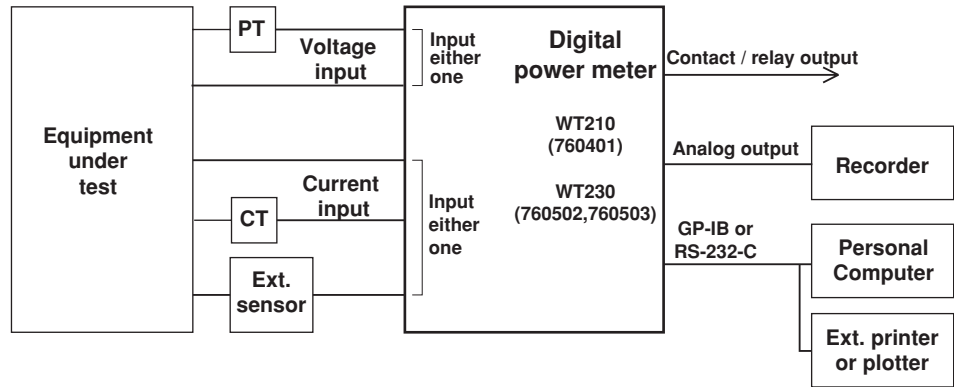

## Block Diagram

Model	Input Section
760401	Built-in input element 1
760502	Built-in input element 1 and 3
760503	Built-in input element 1, 2, and 3

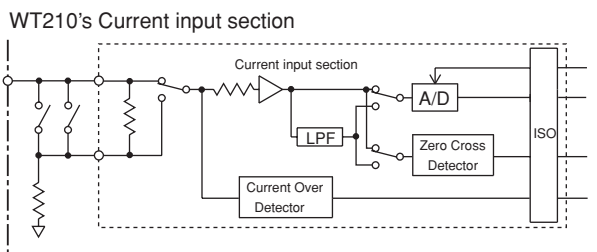
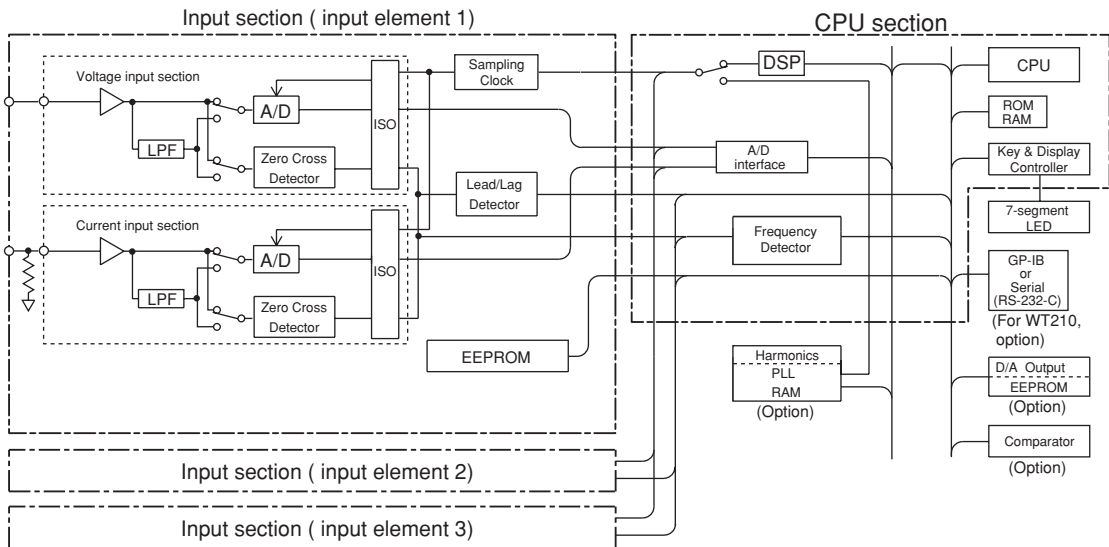

### Signal Flow and Process

The sections that make up the WT210/WT230 are VOLTAGE INPUT, CURRENT INPUT, DSP, CPU, display, and interface.

In the voltage input circuit, the input voltage is normalized by a voltage divider and operational amplifier, then sent to the A/D converter. Shunt resistors form a close circuit at the current input circuit. The voltage across shunt resistor is amplified and normalized by the operational amplifier and then input to the A/D converter. This method enables switching of the current range without opening the current input circuit, so the current range can be switched while power is supplied to the circuit. This also enables remote control via communications outputs. The WT210 equipped with two shunt resistors, one for minute currents and another for large currents,.

The output from the A/D converter in the current input and voltage input circuits is sent to the DSP (Digital Signal Processor) via a photo-isolator (ISO), which is used to provide insulation between the current input circuit (or voltage input circuit) and the DSP.

During normal measurement, the DSP converts digital values sampled at a period of approximately 20  $\mu$ s to voltage, current, and active power; sums the values over a predetermined period; and then divides the sum by the number of samples to derive the measured value of voltage, current, and active power. In addition, to achieve high accuracy, the start and end points of sampling are determined by synchronizing to the zero-crossing point of the voltage or current signal that you select to be measured. From the voltage, current, and active power, the DSP computes the apparent power, reactive power, power factor, and phase angle and performs processing such as scaling and averaging. During harmonic measurement, the DSP performs FFT based on the digital values sampled at an integer multiple of the period of the PLL source signal (period of the clock that the PLL circuit generates) and determines the measured values of various items of harmonic measurement.

The measured value is transmitted to the CPU section. Various computed values such as  $\Sigma$  and MATH are determined from the measured values. These measured values and computed values are displayed (on the 7-segment LED), output through a D/A converter, or output through communications.

During normal measurement, the processing on the DSP and CPU is pipelined, and the DSP processing is performed in real-time. Therefore, measurements with few data dropouts can be achieved against the input signal.

## 2.1 List of Tests and Testing Environment

Self Test  
 Display Test  
 Key Test  
 Tilt Drop Test  
 Insulation Resistance Test  
 Withstand Voltage Test  
 Excessive Input Tests  
 Test of Autorange, Peak Over, and Protective Features  
 Input Impedance Test  
 Communications Function Tests  
 Remote Control Tests  
 Accuracy Tests  
 Linearity Test  
 Zero Power Factor Test  
 Harmonic Analysis Function Tests  
 Low Voltage Commands Tests

### Testing Environment

Temperature:  $23 \pm 2^\circ\text{C}$   
 Humidity: 45–75% RH

### Power Supply and Test Equipment

The following is a list of the recommended test equipment.

• Working standard	YOKOGAWA WT210 or WT1600 or equivalent	1
• Current amplifier	FLUKE 5220A or GUILDLINE 7620 or equivalent	1
• DC voltage generator	YOKOGAWA 2552-02 or equivalent	1
• DC voltage generator	YOKOGAWA 7651 or equivalent	1
• AC voltage generator	NF1520 or equivalent	2
• AC voltage/current generator	YOKOGAWA 2558 or equivalent	1
• DMM	YOKOGAWA 7562 or equivalent	1
• Synchronizer	YOKOGAWA FG120 or equivalent	1
• Current amplifier*	YOKOGAWA B9295ZY	1
• Insulation tester	YOKOGAWA 3213 500 V 100 M $\Omega$ or equivalent	1
• Withstand voltage tester	TAMADENSOKU.Co.,Ltd. M/TT-510ADT	1

\* Not necessary if using the GUILDLINE 7620 current amplifier or equivalent.

## 2.2 List of Connection Diagrams

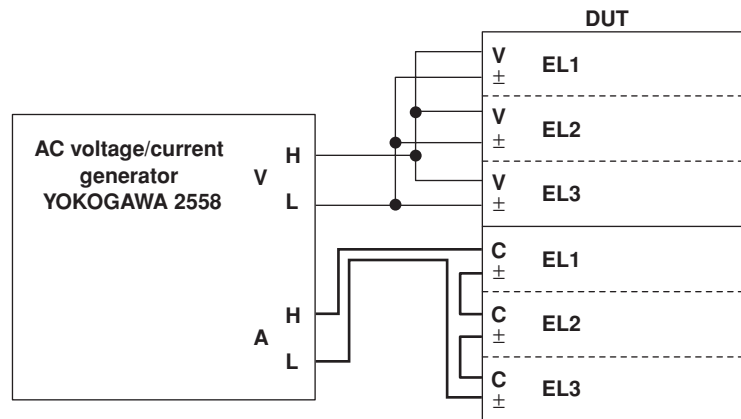

Figure 2-1 Connection diagrams for the Excessive Input Tests, Test of Autorange, Peak Over, and Protective Features, and the Input Impedance Test.

- Connections for the DC Accuracy Test

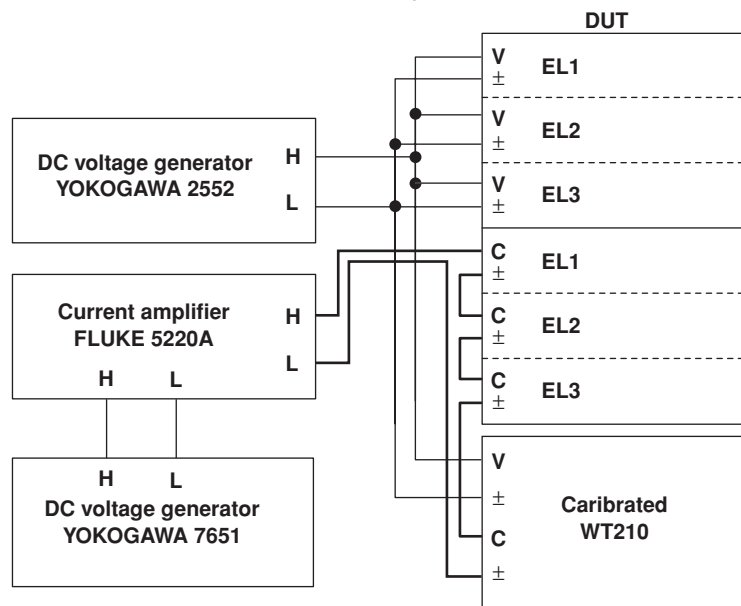

Figure 2-2 Connections for the DC Accuracy Test

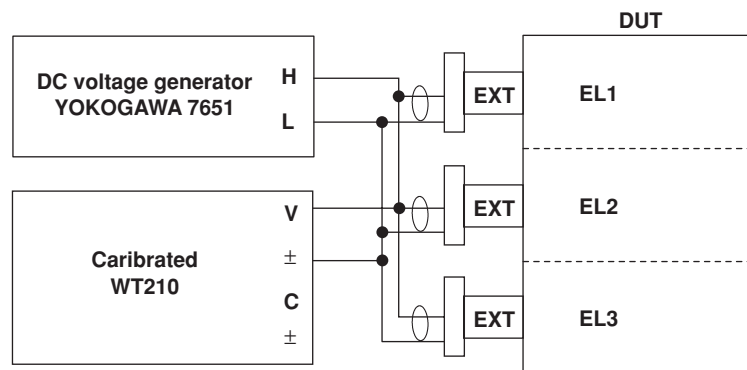

Figure 2-3 Connections for the External Sensor Input (/EX1) DC Accuracy Test

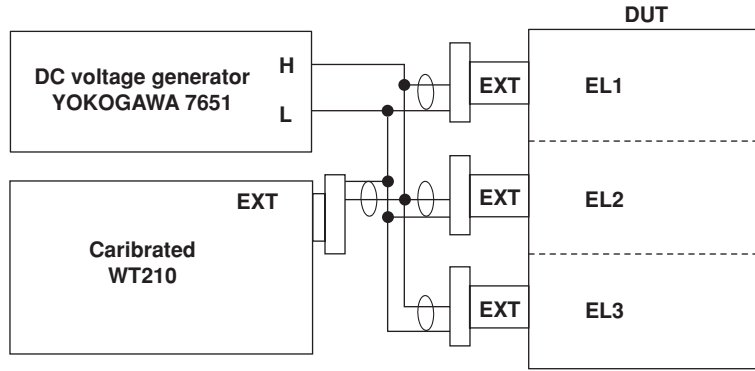

Figure 2-4 Connections for the External Sensor Input (/EX2) DC Accuracy Test

• Connections for the AC Accuracy Test

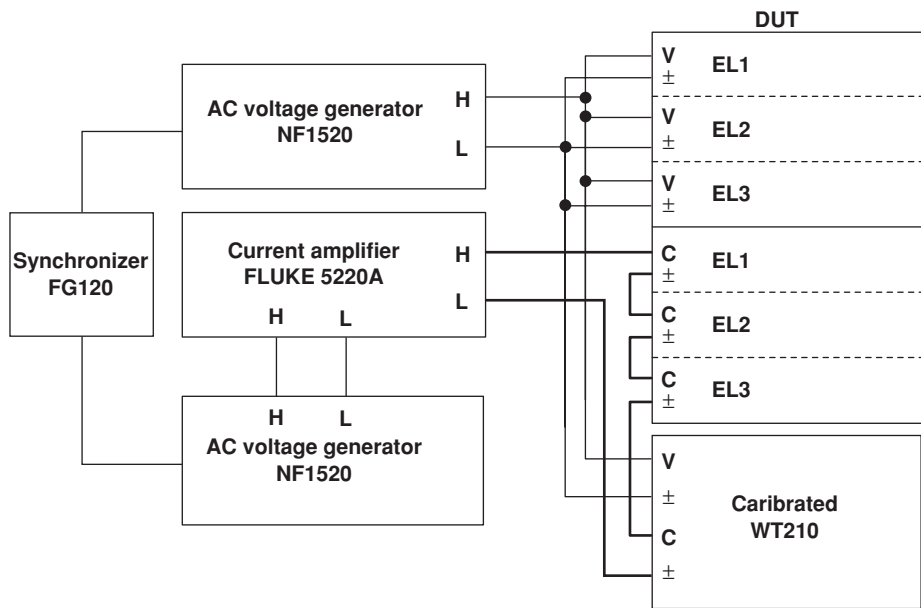

Figure 2-5 Connections for the AC Accuracy Test, Input Range  $\geq 500$  mA

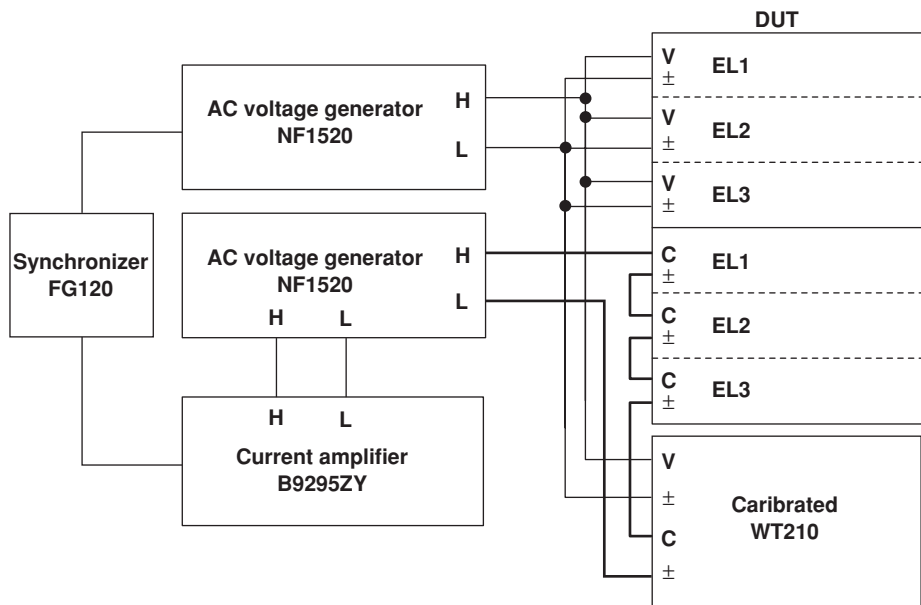

Figure 2-6 Connections for the AC Accuracy Test, Input Range  $< 500$  mA

## 2.2 List of Connection Diagrams

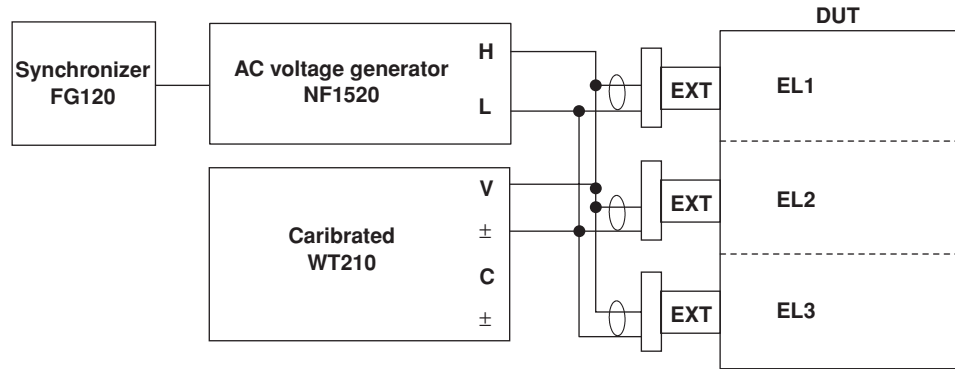

Figure 2-7 Connections for the External Sensor Input (/EX1) AC Accuracy Test

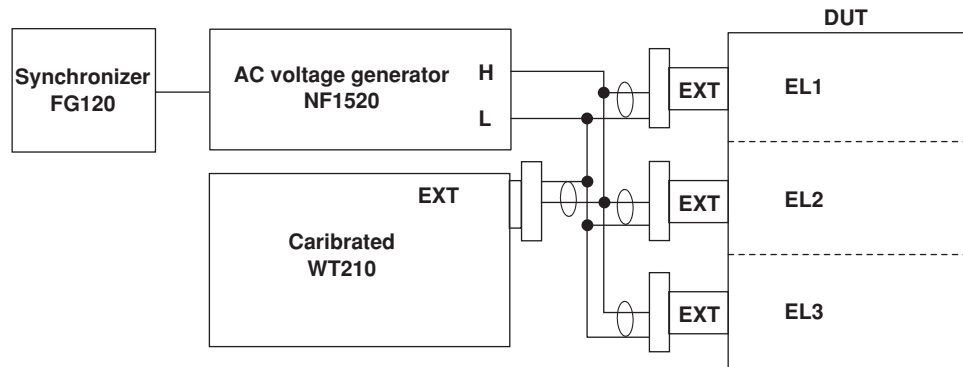

Figure 2-8 Connections for the External Sensor Input (/EX2) AC Accuracy Test

## 2.3 Testing Procedures

### Self Test

When the power is turned ON, the self test is executed. The steps included in the self test are as follows:

DISPLAY A	DISPLAY B	DISPLAY C	Cause
462 10/46230		TEST	
<Error Message>		Err 79	CPU ROM checksum error
		Err 80	CPU RAM read/write check error
<All LEDs light>			
<All LEDs go out>			
<Error Message>		Err 90	Board combination error
		Err 61*	EL1 input correction data (EEPROM) malfunction
		Err 62*	EL2 input correction data (EEPROM) malfunction
		Err 63*	EL3 input correction data (EEPROM) malfunction
		Err 64	D/A output correction data (EEPROM) malfunction
		Err 68	Problem with stored data file
		Err 60	Problem with panel setting backup data
		Err 78	Problem with communications settings data
462 10/46230 -03			Model name display
462 10/46230 101			ROM version display, option display
<Option>			
462 10/46230 101		E-1	/EX1 option
462 10/46230 101		E-2	/EX2 option
462 10/46230 101		HRM	/HRM option
462 10/46230 101		DA	/DA4, /DA12, /CMP options
462 10/46230 101		RELAY	/CMP option
462 10/46230 GP-1 b		Addr	/C1 (communications mode display)
462 10/46230 GP-1 b		Addr. 1	/C1 (address display)
462 10/46230 r 5232		nor	/C2 (communications mode display)
462 10/46230 r 5232		HRnd 0	/C2 (handshaking display)
462 10/46230 r 5232		For 0	/C2 (format display)
462 10/46230 r 5232		b9b00	/C2 (baud rate display) error message
<Error Message>			
462 10/46230 r 5232		Err 71	Malfunction in communications with DSP (RESET, BUS)
462 10/46230 r 5232		Err 73	Malfunction in communications with DSP (INTD)
462 10/46230 r 5232		Err 75	DSP internal error
462 10/46230 r 5232		Err 72	Malfunction in communications with DSP (MEST)
462 10/46230 r 5232		Err 84	Sample clock for DSP malfunction
462 10/46230 r 5232		Err 81	Malfunction in SRAM harmonic board

\* The EEPROM in errors 61, 62, and 63 are duplexed. If one of these errors is displayed when the power to the instrument is turned ON, restart the instrument.

If no errors occur on the second attempt, servicing is not necessary.

### Display Test

1. Hold down the **FUNCTION B** key while turning ON the power switch. Continue to hold down the FUNCTION B key until the option code is displayed. CAL is displayed when the instrument has entered Test/Adjustment mode.
2. Use the  $\wedge$  or  $\vee$  key to select *tEst*, then press **ENTER**.
3. Use the  $\wedge$  or  $\vee$  keys to select *L Ed*, then press **ENTER**. The display test starts. The following outlines the steps that are carried out during the test.
  1. All LEDs light (approximately 5 seconds).
  2. LEDs go out.
  3. LEDs light in the following order: VOLTAGE, CURRENT, RMS, VOLTAGE MEAN, DC, and MAX HOLD.
  4. LEDs light in the following order: SCALLING, AVG, LINE, FREQ, STORE, RECALL, HARMONICS, and KEY LOCK.
  5. LEDs for the keys on the right side of the front panel light one after the other from the upper left to lower right.
  6. Starting on the left side, the 7 segment LEDs light one segment at a time in the order DISPLAY A, DISPLAY B, DISPLAY C.
  7. All LEDs light (approximately 5 seconds).
  8. LEDs go out.
4. Use the  $\wedge$  or  $\vee$  keys to select **End**, then press **ENTER**.

### Key Test

1. Hold down the **FUNCTION B** key while turning ON the power switch. Continue to hold down the FUNCTION B key until the option code is displayed. CAL is displayed when the instrument has entered Test/Adjustment mode.
2. Use the  $\wedge$  or  $\vee$  keys to select *tEst*, then press **ENTER**.
3. Use the  $\wedge$  or  $\vee$  keys to select *P nL*, then press **ENTER**. The following is displayed.
 

DISPLAY A	DISPLAY B	DISPLAY C
<i>P nEL</i>	<i>tEst</i>	<i>r EAdY</i>
4. Press any key. The number corresponding to the key appears in DISPLAY C. The figure below shows the numbers for each key. Press the remainder of the keys and confirm that the correct number is displayed.

WT210

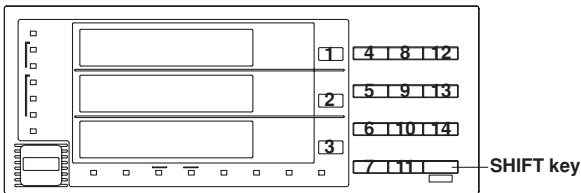

WT230

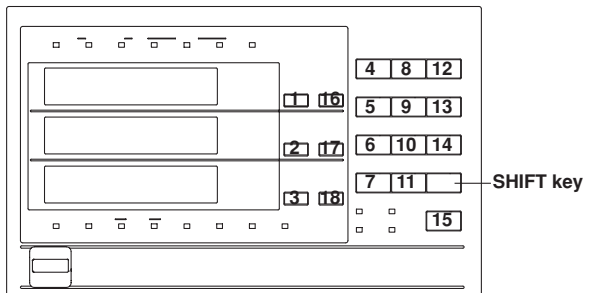

5. Press the SHIFT key to end the key test.

**Note**

If the /CMP option is installed, the key number and contact output are linked. For example, if you press key number 1, *n.c.* appears in DISPLAY C, the connection from COM on CH1 of the comparator output changes from N.C. to N.O., and an "click" can be heard.

### Tilt Drop Test

1. Tilt the front of the instrument 25 mm off of the surface of the desk, then allow the instrument to fall back down onto the desk. Repeat for the back, left, and right side of the instrument.
2. Turn ON the instrument and confirm that it functions properly.

### Insulation Resistance Test

1. Short the V and  $\pm$  sides of the voltage input terminal, and the C and  $\pm$  sides of the current input terminal.
2. Take the measurements listed below using a 500 V insulation resistance tester, and confirm a resistance of 50 M $\Omega$  or more.
  - Across all voltage input terminals together and the case\*
  - Across all current input terminals together and the case\*
  - Across all voltage input terminals together and all current input terminals together
  - Across all voltage input terminals together and the power plug
  - Across all current input terminals together and the power plug
  - Across the case and the power plug

\* Use the power supply grounding terminal for the case.

### Withstand Voltage Test

1. Short the V and  $\pm$  sides of the voltage input terminal, and the C and  $\pm$  sides of the current input terminal.
2. Apply 50/60 Hz, 3700 V, and CURRENT LIMIT: 10 mA across the terminals listed below for one minute using a withstanding voltage tester, then confirm that the instrument does not incur any dielectric breakdown.
  - Across all voltage and current input terminals together (shorted) and the case\*
  - Across all voltage input terminals together and all current input terminals together
  - Across all voltage and current input terminals together and the power plug
3. Apply 50/60 Hz, 1500 V, and CURRENT LIMIT: 10 mA across the terminals listed below for one minute using a withstanding voltage tester, then confirm that the instrument does not incur any dielectric breakdown.
  - Across the case and the power plug

\* Use the power supply grounding terminal for the case.

### Excessive Input Tests

Connect the devices according to Figure 2-1.

#### • Voltage Input

1. Set the input range to **600 V**.
2. Connect an AC voltage generator, apply 1000 V/60 Hz each for 10 seconds, then measure 100 V and confirm that no abnormalities are present. If any abnormalities occur, replace the main board of the WT210, or the input board of the WT230.

#### • Current Input

1. Change the input range to 5 A, then apply 30 A/60 Hz for 10 seconds.
2. Set the AC current generator to 1 A, then take a measurement using the instrument and confirm that it functions normally.

### Test of Autorange, Peak/Range Over, and Protective Features

Connect the devices according to Figure 2-1.

1. Set the update rate to 250 ms.  
Press the **SETUP** key, use the  $\wedge$  or  $\vee$  keys to select **U.R.FRE**, then press **ENTER**.  
Use the  $\wedge$  or  $\vee$  keys to select **0.25**, then press **ENTER**. The update rate is changes to 250 ms.
2. Turn OFF the output from the voltage/current generator, then set the input to **0**.  
Press the **VOLTAGE** key, use the  $\wedge$  or  $\vee$  keys to select **Auto**, then press **ENTER**.  
Press the **CURRENT** key, use the  $\wedge$  or  $\vee$  keys to select **Auto**, then press **ENTER**.
3. Set the voltage and current ranges on the voltage/current generator to **AUTO**, then set **MODE** to **RMS**.
4. Press the **VOLTAGE** key, confirm that 15 V is displayed, then press **VOLTAGE** once again.
5. Press the **CURRENT** key, then confirm that either 5 mA is displayed for the WT210, or 0.5 A is displayed for the WT230, then press **CURRENT** once again.
6. Connect the AC voltage source to the voltage input terminal on the rear panel of the WT210/WT230, then apply 600 V/60 Hz.
7. The **VOLTAGE** lamp lights, and the voltage range increases from 30 to 60 to 150 V at each display update cycle. Confirm that the display shows - - - - -.
8. Confirm the following: at the 300 V range - -  $\square \uparrow$  - is displayed, the range increases to 600 V at the next display update, the **VOLTAGE** indicator goes out, and finally the measured value is displayed.
9. Turn OFF the output from the AC voltage generator.
10. The range increments down at each display update cycle. Confirm that the display shows - - - - -.  
Five display update cycles after the output (1.25 seconds later), the instrument changes to the 15 V range and the measured value is displayed.
11. Press the **VOLTAGE** key, confirm that the instrument is set to the 15 V range, then press the **VOLTAGE** key again.
12. Connect the AC current source to the current input terminal on the rear panel of the WT210/WT230, then apply 20 A/60 Hz.
13. The **CURRENT** indicator lights, and the current range increments at each display update cycle from 5 mA–10mA for the WT210, or 500 mA–1 A for the WT230. The protective features engage approximately 0.5 seconds after applying the current, then the current range increments to 1 A.  
The range increments from 1 to 2 to 5 A at each display update cycle.  
Confirm that the display shows - - - - -.
14. Confirm the following: at the 10 A range - -  $\square \uparrow$  - is displayed, the range increases to 20 A at the next display update, the **CURRENT** indicator goes out, and finally the measured value is displayed.
15. When you turn OFF the output from the AC current generator, the range decrements 1 range per display update cycle. Confirm that the display shows [- - - - -]. For the WT210, the range changes to 5 mA eleven display update cycles after turning OFF the output from the AC voltage generator (2.75 seconds later), and the measured value is displayed. For the WT230, the range changes to 500 mA five display update cycles later (1.25 seconds later).
16. Turn OFF **AUTO** Range on the AC current generator. For the WT230, skip to step 22.
17. Set the current range on the WT210 to 200 mA.  
Press the **CURRENT** key, use the  $\wedge$  or  $\vee$  keys to select **200 mA**, then press **ENTER**.
18. Connect the AC current source to the current input terminal, then apply 1 A/60 Hz.

19. The protective features activate approximately 0.5 seconds thereafter. Confirm that the relay activation alarm sounds.  
The display reads  $\text{-OL-}$ .
20. Set the AC current generator to **0.24 A**.
21. After one display update cycle (0.25 seconds later), confirm that the protective features activation, the current range returns to 200 mA, and that the relay activation alarm sounds. The display shows the measured value.
22. Turn OFF the output from the AC current generator.

### Input Impedance Test (WT210)

Connect the devices according to Figure 2-1.

1. Hold down the **FUNCTION B** key while turning ON the power switch. Continue to hold down the FUNCTION B key until the option code is displayed.  
The instrument enters CAL mode.
2. Use the  $\wedge$  or  $\vee$  keys to select *RELAY*, then press **ENTER**. The instrument enters input impedance testing mode.
3. Set the AC current generator to 500 mA/60 Hz, then send the input to the WT210.
4. Confirm that the displayed value is 2 A or less.
5. Turn OFF the power then turn it back ON again to exit input impedance testing mode.

### Communications Function Tests

#### • GP-IB

1. Connect the instrument to a PC capable of receiving remote control commands via GP-IB, then run the sample programs described in sections 13.4 and 13.5 of the user's manual (IM 760401-01E).
2. Confirm that the operation functions normally.

#### **Note**

The above test can be omitted if the functions were determined to be normal during the self test.

#### • SERIAL (RS-232-C)

1. Connect the instrument to a PC capable of receiving remote control commands via RS-232, then run the sample programs described in sections 13.4 and 13.5 of the user's manual (IM 760401-01E).
2. Confirm that the operation functions normally.

#### **Note**

The above test can be omitted if the functions were determined to be normal during the self test.

### Remote Control Tests (Only If the /DA12 or /DA4 or /CMP Option Is Installed)

Connect an external I/O connector and pulse generator (such as the FG120). See section 9.1 of the manual, IM 760401-01E for pin layout and signal assignments.

1. Specify an external control signal at TTL level, negative pulse, and pulse width of 4 ms.

- **Hold/Trigger Function (Only If the /DA12 or /DA4 or /CMP Option Is Installed)**

2. Apply the negative pulse to the EXT-HOLD terminal. The display enters hold status.
3. Apply an arbitrary voltage to the voltage input terminal, then apply the negative pulse to the EXT-TRIG terminal.
4. Confirm that DISPLAY no longer appears on the screen.

- **Computation Control Function (Only If the /DA12 or /DA4 or /CMP Option Is Installed)**

2. Press the **FUNCTION C** key, then set **DISPLAY C** to display **Wh** or **Ah**.
3. Apply the negative pulse to the EXT-START terminal.
4. Confirm that the START indicator lights, and that computation begins.
5. Apply the negative pulse to the EXT-STOP terminal.
6. Confirm that the START indicator goes out, that the STOP indicator lights, and that computation stops.
7. Apply the negative pulse to the EXT-RESET terminal.
8. Confirm that - - - - - appears on DISPLAY C.

### Accuracy Tests

1. After allowing a warmup for the instruments as shown in the table below, perform the test.  
DUT: 30 minutes or more  
Calibration device: at least 1 hour

**Note**

---

Use a calibrated working standard, and use the calibrated values for the test.

---

- **Panel Settings**

1. Set the update rate to **250 ms**.  
Press **SETUP**. Use the  $\wedge$  or  $\vee$  keys to select *u.r ALE*, then press **ENTER**. Use the  $\wedge$  or  $\vee$  keys to select *0.25*, then press **ENTER**.
2. Press **SETUP**. Use the  $\wedge$  or  $\vee$  keys to select one of the items below, and enter the settings as shown.  
*L.F, Lt: OFF*  
*F.F, Lt: OFF*  
*ABG: OFF*  
*SCALE: OFF*  
*SYN: set to B to test voltage, and A to test current.*  
*Ern: 1.000 A (EX1 or EX2 option only)*

• **Voltage Accuracy Test**

Perform the test procedure described below on all elements using each combination of range and frequency shown in the table (do not test the combinations indicated by a bar —).

**Note**

- Perform zero level compensation before testing with DC voltage input.
- For frequencies exceeding 60 Hz, set the instrument to the **150 V** range and the input voltage to **100 V**.
- Combinations indicated by the delta symbol ( $\Delta$ ) should only be tested on instruments for which a test certificate is available.
- Set the instrument to DC measurement mode when inputting DC voltage, and RMS mode when inputting AC voltage.

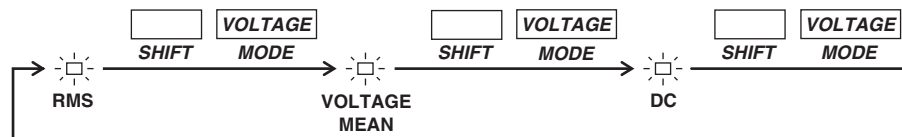

- Also set the instrument MEAN measurement mode when 100 V/60 Hz and 100 V/100 kHz.

RANGE	Direct Current Input Frequency									
	+DC	-DC	10 Hz	60 Hz	1 kHz	10 kHz	20 kHz	50 kHz	100 kHz	
15 V	—	—	—	—	—	—	—	—	—	
30 V	—	—	—	—	—	—	—	—	—	
60 V	—	—	—	—	—	—	—	—	—	
150 V	—	—	$\Delta$	—	$\Delta$	$\Delta$	$\Delta$	$\Delta$	$\Delta$	
300 V	—	—	—	—	—	—	—	—	—	
600 V	—	—	—	—	—	—	—	—	—	
Specification (%)	rdg	0.2	0.2	0.1	0.1	0.1	0.7	0.9	2.1	4.1
	rng	0.2	0.2	0.2	0.1	0.2	0.3	0.5	0.5	0.5

Figure 2-2

Figure 2-5  
Figure 2-6

## 2.3 Testing Procedures

### • Current Accuracy Test

Perform the test procedure described below on all elements using each combination of range and frequency shown in the table (do not test the combinations indicated by a bar —).

#### Note

- Perform zero level compensation before testing with DC current input.
- Combinations indicated by the delta symbol ( $\Delta$ ) should only be tested on instruments for which a test certificate is available.
- Set the instrument to DC measurement mode when inputting DC current, and RMS mode when inputting AC current.
- Enter settings on the external sensor as shown below. For instructions on entering settings on the external sensor, see section 4.6 in user's manual IM 760401-01E.

/EX1: EXT1 = 2.5 V, EXT2 = 5 V, EXT3 = 10 V

/EX2: EXT1 = 50 mV, EXT2 = 100 mV, EXT3 = 200 mV

For the WT210

RANGE	Direct Current Input Frequency									
	+DC	-DC	10 Hz	60 Hz	1 kHz	10 kHz	20 kHz	50 kHz	100 kHz	
5 mA	—	—	—	$\Delta$	—	—	—	—	—	
10 mA	—	—	—	—	$\Delta$	$\Delta$	$\Delta$	—	—	
20 mA	—	—	—	$\Delta$	—	—	—	—	—	
50 mA	—	—	—	—	—	—	—	$\Delta$	—	
100 mA	—	—	—	—	—	—	—	—	—	
200 mA	—	—	—	—	—	—	—	—	—	
500 mA	—	—	—	—	—	—	—	—	—	
1 A	—	—	$\Delta$	—	$\Delta$	$\Delta$	—	—	—	
2 A	—	—	—	—	—	—	—	—	—	
5 A	—	—	—	—	$\Delta$	—	—	—	—	
10 A	—	—	—	—	—	—	—	—	—	
20 A	—	—	—	—	—	—	—	—	—	
EXT1	—	—	—	—	—	—	—	—	—	
EXT2	—	—	—	—	—	—	—	—	—	
EXT3	—	—	—	—	—	—	—	—	—	
Specification (%)	rdg	0.2	0.2	0.1	0.1	0.1	0.7	0.9	2.1	4.1
	rng	0.2	0.2	0.2	0.1	0.2	0.3	0.5	0.5	0.5

Figure 2-2

Figure 2-3  
Figure 2-4

Figure 2-6

Figure 2-5

Figure 2-7  
Figure 2-8

For the WT230

RANGE	Direct Current Input Frequency									
	+DC	-DC	10 Hz	60 Hz	1 kHz	10 kHz	20 kHz	50 kHz	100 kHz	
500 mA	—	—	—	—	—	—	—	—	—	
1 A	—	—	Δ	—	Δ	Δ	—	—	—	
2 A	—	—	—	—	—	—	—	—	—	
5 A	—	—	—	—	Δ	—	—	—	—	
10 A	—	—	—	—	—	—	—	—	—	
20 A	—	—	—	—	—	—	—	—	—	
EXT1	—	—	—	—	—	—	—	—	—	
EXT2	—	—	—	—	—	—	—	—	—	
EXT3	—	—	—	—	—	—	—	—	—	
Specification (%)	rdg	0.2	0.2	0.1	0.1	0.1	0.7	0.9	2.1	4.1
	rng	0.2	0.2	0.2	0.1	0.2	0.3	0.5	0.5	0.5

Figure 2-2

Figure 2-3

Figure 2-4

Figure 2-5

Figure 2-7

Figure 2-8

**Power Accuracy Test**

Perform the test procedure described below on all elements setting each combination to the rated input and power factor = 1 (do not test the combinations indicated by a bar —).

**Note**

- Perform zero level compensation before testing with DC input.
- Combinations indicated by the delta symbol (Δ) should only be tested on instruments for which a test certificate is available.
- Set the instrument to DC measurement mode when inputting DC input, and RMS mode when inputting AC input.

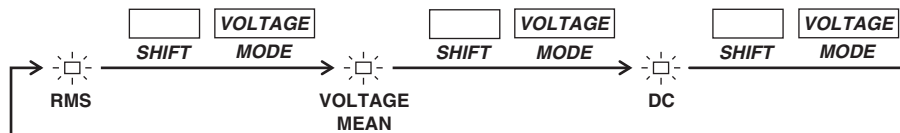

**Set Current Range of 1 A, Apply 1A Rated Input, and Test the Accuracy at Each Voltage Range**

For frequencies other than 60 Hz, set the instrument to the 150 V range and the input voltage to 100 V.

RANGE	Direct Current Input Frequency									
	+DC	-DC	10 Hz	60 Hz	1 kHz	10 kHz	20 kHz	50 kHz	100 kHz	
15 V	—	—	—	—	—	—	—	—	—	
30 V	—	—	—	—	—	—	—	—	—	
60 V	—	—	—	—	—	—	—	—	—	
150 V	—	—	Δ	—	Δ	Δ	—	Δ	—	
300 V	—	—	—	—	—	—	—	—	—	
600 V	—	—	—	—	—	—	—	—	—	
Specification (%)	rdg	0.3	0.3	0.3	0.1	0.2	0.7	1.4	4.1	8.6
	rng	0.2	0.2	0.2	0.1	0.2	0.3	0.5	0.5	0.5

Figure 2-2

Figure 2-5

## 2.3 Testing Procedures

### Set a Voltage Range of 150 V, Apply a Rated Input of 100 V, and Test the Accuracy at Each Current Range

Enter settings on the external sensor as shown below. For instructions on entering settings on the external sensor, see section 4.6 in user's manual IM 760401-01E.

/EX1: EXT1 = 2.5 V, EXT2 = 5 V, EXT3 = 10 V

/EX2: EXT1 = 50 mV, EXT2 = 100 mV, EXT3 = 200 mV

For the WT210

RANGE	Direct Current Input Frequency									
	+DC	-DC	10 Hz	60 Hz	1 kHz	10 kHz	20 kHz	50 kHz	100 kHz	
5 mA	—	—	—	Δ	—	—	—	—	—	
10 mA	—	—	—	—	Δ	Δ	Δ	—	—	
20 mA	—	—	—	Δ	—	—	—	—	—	
50 mA	—	—	—	—	—	—	—	Δ	—	
100 mA	—	—	—	Δ	—	—	—	—	—	
200 mA	—	—	—	—	—	—	—	—	—	
500 mA	—	—	—	—	—	—	—	—	—	
1 A	—	—	—	—	—	—	—	—	—	
2 A	—	—	—	Δ	—	—	—	—	—	
5 A	—	—	—	Δ	—	—	—	—	—	
10 A	—	—	—	Δ	—	—	—	—	—	
20 A	—	—	—	Δ	—	—	—	—	—	
EXT1	—	—	—	—	—	—	—	—	—	
EXT2	—	—	—	—	—	—	—	—	—	
EXT3	—	—	—	—	—	—	—	—	—	
Specification (%)	rdg	0.3	0.3	0.3	0.1	0.2	0.7	1.4	4.1	8.6
	rng	0.2	0.2	0.2	0.1	0.2	0.3	0.5	0.5	0.5

Figure 2-2
Figure 2-3  
Figure 2-4
Figure 2-5
Figure 2-7  
Figure 2-8
Figure 2-6

For the WT230

RANGE	Direct Current Input Frequency									
	+DC	-DC	10 Hz	60 Hz	1 kHz	10 kHz	20 kHz	50 kHz	100 kHz	
500 mA	—	—	—	—	—	—	—	—	—	
1 A	—	—	—	—	—	—	—	—	—	
2 A	—	—	—	Δ	—	—	—	—	—	
5 A	—	—	—	Δ	—	—	—	—	—	
10 A	—	—	—	Δ	—	—	—	—	—	
20 A	—	—	—	Δ	—	—	—	—	—	
EXT1	—	—	—	—	—	—	—	—	—	
EXT2	—	—	—	—	—	—	—	—	—	
EXT3	—	—	—	—	—	—	—	—	—	
Specification (%)	rdg	0.3	0.3	0.3	0.1	0.2	0.7	1.4	4.1	8.6
	rng	0.2	0.2	0.2	0.1	0.2	0.3	0.5	0.5	0.5

Figure 2-2
Figure 2-3  
Figure 2-4
Figure 2-5
Figure 2-7  
Figure 2-8

- **Line Filter Accuracy Test**

Connect the devices according to Figure 2-5.

Test for error at the range and frequency combinations below.

1. Set the voltage range to **150 V**, and the current range to **1 A**.  
Press the **VOLTAGE** key, use the  $\wedge$  or  $\vee$  keys to select **150**, then press **ENTER**.  
Press the **CURRENT** key, use the  $\wedge$  or  $\vee$  keys to select **1**, then press **ENTER**.
2. Turn the line filter OFF.  
Press the **SETUP** key, use the  $\wedge$  or  $\vee$  keys to select **L.F, L $\bar{L}$** , then press **ENTER**.  
Use the  $\wedge$  or  $\vee$  keys to select **oFF**, then press **ENTER**.

#### Calculating Error for 60 Hz

3. Input a signal with a frequency of 60 Hz, current of 1 A, and a rated voltage of 150 V. DFoff is displayed.
4. Turn the line filter ON.  
Press the **SETUP** key, use the  $\wedge$  or  $\vee$  keys to select **L.F, L $\bar{L}$** , then press **ENTER**.  
Use the  $\wedge$  or  $\vee$  keys to select **on**, then press **ENTER**. DFon is displayed.
5. Calculate the error using the following equation.  
Error (%) = (DFon – DFoff)/DFoff  $\times$  100.

#### Calculating Error for 500 Hz

3. Input a signal with a frequency of **500 Hz**, current of **1 A**, and a rated voltage of **150 V**. DFoff is displayed.
4. Turn the line filter ON.  
Press the **SETUP** key, use the  $\wedge$  or  $\vee$  keys to select **L.F, L $\bar{L}$** , then press **ENTER**.  
Use the  $\wedge$  or  $\vee$  keys to select **on**, then press **ENTER**. DFon is displayed.
5. Calculate the error using the following equation.  
Error (%) = (DFon – DFoff  $\times$  0.708)/DFoff  $\times$  100

RANGE		60 Hz	500 HZ
150 V			
1 A			
Specification (%)	rdg	0.2	20
	rng	—	—

## 2.3 Testing Procedures

### • Integration: Wh and Ah

Connect the devices according to Figure 2-5.

1. Press the **FUNCTION C** key repeatedly to select **Wh**.
2. Set the update rate to **250 ms**.  
Press the **SETUP** key, use the  $\wedge$  or  $\vee$  keys to select **UPDATE**, then press **ENTER**.  
Use the  $\wedge$  or  $\vee$  keys to select **0.25**, then press **ENTER**.
3. Select the measurement mode to **RMS**.

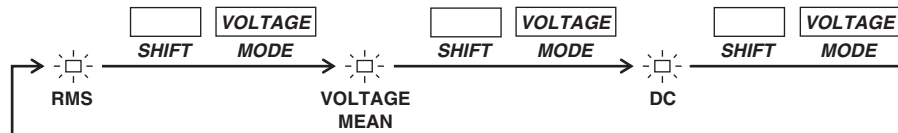

4. Turn the line filter OFF.  
Press the **SETUP** key, use the  $\wedge$  or  $\vee$  keys to select **LF Lt**, then press **ENTER**.  
Use the  $\wedge$  or  $\vee$  keys to select **OFF**, then press **ENTER**.
5. Turn averaging OFF.  
Press the **SETUP** key, use the  $\wedge$  or  $\vee$  keys to select **AVE**, then press **ENTER**.  
Use the  $\wedge$  or  $\vee$  keys to select **OFF**, then press **ENTER**.
6. Turn scaling OFF.  
Press the **SETUP** key, use the  $\wedge$  or  $\vee$  keys to select **SCALE**, then press **ENTER**.  
Use the  $\wedge$  or  $\vee$  keys to select **OFF**, then press **ENTER**.
7. Set the voltage range to **150 V** and the current range to **1 A**.  
Press the **VOLTAGE** key, use the  $\wedge$  or  $\vee$  keys to select **150**, then press **ENTER**.  
Press the **CURRENT** key, use the  $\wedge$  or  $\vee$  keys to select **1**, then press **ENTER**.
8. Set the integration time to **one minute**.  
Press the **SHIFT** key, then press **RESET**.  
Use the  $\wedge$  or  $\vee$  keys to select **1 min**, then press **ENTER**.
9. Input a rated value of **150 V/1 A, 60 Hz/COS  $\phi = 1$** .
10. Adjust the signal source so that the display matches the rated input value.
11. Integration starts. Press the **START** key.
12. Confirm that the value at the point when integration stopped meets the specifications.
13. Press **FUNCTION C** repeatedly to select **Ah**, then repeat steps 1–12 and confirm that the values meet the specifications below.

	Wh	Ah (RMS)
Specifications	Device accuracy $\pm 0.1\%$ of rdg	Device accuracy $\pm 0.1\%$ of rdg

### • Frequency Measurement

Connect the devices according to Figure 2-5.

- Set the voltage range to **150 V**, and the current range to **1 A**.  
Press the **VOLTAGE** key, use the  $\wedge$  or  $\vee$  keys to select *150*, then press **ENTER**.  
Press the **CURRENT** key, use the  $\wedge$  or  $\vee$  keys to select *1*, then press **ENTER**.
- Set the update rate to **250 ms**.  
Press the **SETUP** key, use the  $\wedge$  or  $\vee$  keys to select *UPDATE*, then press **ENTER**.  
Use the  $\wedge$  or  $\vee$  keys to select *0.25*, then press **ENTER**.
- Turn the frequency filter ON.  
Press the **SETUP** key, use the  $\wedge$  or  $\vee$  keys to select *FF, LE*, then press **ENTER**.  
Use the  $\wedge$  or  $\vee$  keys to select *ON*, then press **ENTER**.
- Enter combinations of settings for frequency, voltage, and current on the AC voltage generator as shown in the table below, then input the signals to the instrument.
- Confirm that the measured values meet the specification.

Input Frequency	Input Voltage	Input Current	Specification
60 Hz	150 V	0	$\pm 0.06\%$ of rdg
60 Hz	0 V	1 A	$\pm 0.06\%$ of rdg
4 Hz	150 V	1 A	Err-Lo
5 kHz	150 V	1 A	Err-Lo

### • Phase Lead/Lag Test

Connect the devices according to Figure 2-5.

- Set the AC voltage generator to **150 V, 1 A, 1 kHz**.
- Set the voltage range to **150 V** and the current range to **2 A**.  
Press the **VOLTAGE** key, use the  $\wedge$  or  $\vee$  keys to select *150*, then press **ENTER**.  
Press the **CURRENT** key, use the  $\wedge$  or  $\vee$  keys to select *1*, then press **ENTER**.
- Adjust the level so that WATT under DUT is at **0**. The phase on the function generator is set to A.
- Using the phase angle display A on the function generator as a reference, set the phase angle to **A+90°**. The phase angle display is set to B.
- Using phase angle display B as a reference, adjust the phase angle on the function generator until the leading/lagging phase becomes completely **d** or **G**. The phase angle display on the function generator is set to C.
- Calculate using a detection angle of C–B, then confirm that the result meets the following specification.  
Specification:  $\pm 5^\circ$

## 2.3 Testing Procedures

### • Analog Output (Only If the /DA12 or /DA4 or /CMP Option Is Installed)

Connect the devices according to Figure 2-5.

- Set all DA output elements to **V1**.  
Press the **SHIFT** key, then press **SETUP**.  
Use the  $\wedge$  or  $\vee$  keys to select  $dR$ , then press **ENTER**.  
Use the  $\wedge$  or  $\vee$  keys to select  $SEL$ , then press **ENTER**.  
Use the  $\wedge$  or  $\vee$  keys to select  $Ch 1$ , then press **ENTER**. Use the  $\wedge$  or  $\vee$  keys to select  $V 1$ , then press **ENTER**. In the same manner, set all other channels from ch 2 to V1.
- Press the **FUNCTION** and **ELEMENT** keys (WT230 only) to set the function of all elements to  $V$ .
- Set the voltage range to **150 V** and the current range to any value.  
Press the **VOLTAGE** key, use the  $\wedge$  or  $\vee$  keys to select  $150$ , then press **ENTER**.  
Press the **CURRENT** key, use the  $\wedge$  or  $\vee$  keys to select an arbitrary range, then press **ENTER**.
- Select the measurement mode to **RMS**.

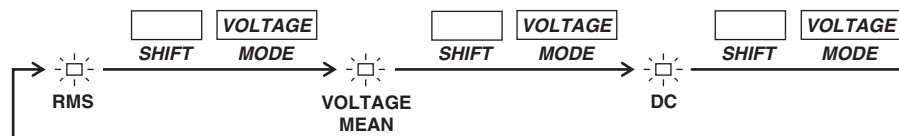

- Connect the AC voltage generator, then input 150 V/60 Hz.
- Adjust the output of the generator so that the display shows 150.0 V.
- Confirm that all DA output values are read on the digital multimeter, and that the specification in the table below are met.

Specification:  $\pm(\text{display accuracy} + 0.2\% \text{ of FS})$

### • Linearity Test

Take measurements at all combinations as shown in the table below (except where indicated by a bar —), and confirm that the results meet the test specification.

#### Note

- Combinations indicated by the delta symbol ( $\Delta$ ) should only be tested on instruments for which a test certificate is available.
- Perform zero level compensation before testing with DC input.

#### Voltage

- Set the voltage range to **600 V**.  
Press the **VOLTAGE** key, use the  $\wedge$  or  $\vee$  keys to select  $600$ , then press **ENTER**.
- Set the measurement mode to **DC** for DC input, and **RMS** for AC input.



- Take measurements at the input voltage and frequency combinations below, and confirm that the results meet the specification.  
Use the procedure below when testing with an input voltage of 6 V.

- Set the voltage range of the DUT to **15 V**.
- Adjust the AC voltage generator so that the DUT's display reads **6 V**. The value displayed on the AC voltage generator is to be used for the Vref value in the error equation below.

**Note**

- If the error set on the AC voltage generator is below 1%, it's OK to set the display to 6 V.
- You can also use 6/15 from the 15 V calibration value on the working standard.

- Set the voltage range of the DUT to **600 V**. The value displayed on the **DUT** is Vint in the equation below.
- The error is calculated.  $\text{Error [V]} = \text{Vint} - \text{Vref}$

Measurement Mode	DC		RMS	Expected Result [V]		
	+DC	-DC	60 Hz	+DC	-DC	60 Hz
300	Δ	Δ	Δ	300.00	-300.00	300.00
100	Δ	Δ	Δ	100.00	-100.00	100.00
60	Δ	Δ	Δ	60.00	-60.00	60.00
6	—	—	*			6.00

Figure 2-2

Figure 2-5

\* This combination performs a test, but the results will not appear on the test certificate.

**Specification**

Input Voltage (V)	DC		60 Hz
300	0.2% of rdg	0.2% of rng	0.1% of rdg 0.1% of rng
100	0.2% of rdg	0.2% of rng	0.1% of rdg 0.1% of rng
60	0.2% of rdg	0.2% of rng	0.1% of rdg 0.1% of rng
6	0.2% of rdg	0.2% of rng	0.1% of rdg 0.1% of rng

**Current**

- Set the current range to **1 A**.  
Press the **CURRENT** key, use the ^ or v keys to select *i*, then press **ENTER**.
- Set the measurement mode to **DC** for DC input, and **RMS** for AC input.

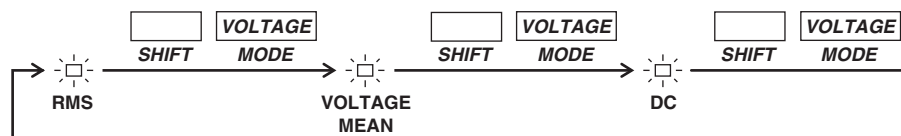

- Take measurements at the input current and frequency combinations below, and confirm that the results meet the specification.

MEASURING MODE	DC		RMS	Expected Result [A]		
	+DC	-DC	60 Hz	+DC	-DC	60 Hz
0.6	Δ	Δ	Δ	0.6000	-0.6000	0.6000
0.2	Δ	Δ	Δ	0.2000	-0.2000	0.2000
0.1	Δ	Δ	Δ	0.1000	-0.1000	0.1000
10 mA	—	—	*			0.0100

Figure 2-2

Figure 2-5

\* This combination performs a test, but the results will not appear on the test certificate.

## 2.3 Testing Procedures

Input Current (A)	Specification	
	DC	60 Hz
0.6	0.2% of rdg 0.2% of rng	0.1% of rdg 0.1% of rng
0.2	0.2% of rdg 0.2% of rng	0.1% of rdg 0.1% of rng
0.1	0.2% of rdg 0.2% of rng	0.1% of rdg 0.1% of rng
10 mA	0.2% of rdg 0.2% of rng	0.1% of rdg 0.1% of rng

### Power

- Set the voltage range to **600 V** and the current range to **1 A**.  
Press the **VOLTAGE** key, use the  $\wedge$  or  $\vee$  keys to select  $600$ , then press **ENTER**.  
Press the **CURRENT** key, use the  $\wedge$  or  $\vee$  keys to select  $1$ , then press **ENTER**.
- Set the measurement mode to **DC** for DC input, and **RMS** for AC input.

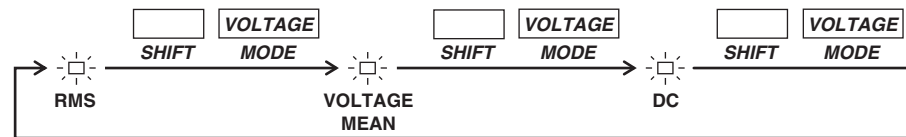

- Set the input current to **1 A** in all cases, and the input voltage according to the table below. Set the 60 Hz–AC voltage to **COS  $\phi$  =1**.  
Confirm that the measured values meet the specification.

MEASURING MODE	DC		RMS	Expected Result [W]		
	+DC	-DC	60 Hz	+DC	-DC	60 Hz
Input Voltage (V)						
100	$\Delta$	$\Delta$	$\Delta$	100.00	-100.00	100.00
60	$\Delta$	$\Delta$	$\Delta$	60.00	-60.00	60.00

Figure 2-2

Figure 2-5

Input Voltage (V)	Specification	
	DC	60 Hz
100	0.3% of rdg 0.2% of rng	0.1% of rdg 0.1% of rng
60	0.3% of rdg 0.2% of rng	0.1% of rdg 0.1% of rng

- **Zero Power Factor Test**

Connect the devices according to Figure 2-5.

With an input frequency of 60 Hz, set the phase lead/lag per the table below (except as indicated by the bar —).

1. Set the current range to 5 A.  
Press the **CURRENT** key, use the  $\wedge$  or  $\vee$  keys to select  $\underline{5}$ , then press **ENTER**.
2. Set the voltage range as shown below.  
Press the **VOLTAGE** key, use the  $\wedge$  or  $\vee$  keys to select a voltage range from the table below, then press **ENTER**.
3. Input the voltage. Input **10 V** at the 15 V range, and **100 V** at the 150 V range.
4. Confirm that the measured values meet the specification.

Frequency	60 Hz	
Voltage range	LEAD	LAG
15 V		
30 V	—	—
60 V	—	—
150 V		
300 V	—	—
600 V	—	—

Specification:  $\pm 0.20\%$  of rng

- **Harmonic Analysis Function Tests (Only If the /HRM Option Is Installed)**

1. Turn averaging, scaling, and the line filter OFF.  
Press the **SETUP** key, use the  $\wedge$  or  $\vee$  keys to select *AVE*, then press **ENTER**.  
Use the  $\wedge$  or  $\vee$  keys to select *OFF*, then press **ENTER**.  
Press the **SETUP** key, use the  $\wedge$  or  $\vee$  keys to select *SCALE*, then press **ENTER**.  
Use the  $\wedge$  or  $\vee$  keys to select *OFF*, then press **ENTER**.  
Press the **SETUP** key, use the  $\wedge$  or  $\vee$  keys to select *LF, LL*, then press **ENTER**.  
Use the  $\wedge$  or  $\vee$  keys to select *OFF*, then press **ENTER**.
2. Place the working standard in normal measurement mode.

**Voltage Accuracy Test**

3. Set the voltage range to 150 V.  
Press the **VOLTAGE** key, use the  $\wedge$  or  $\vee$  keys to select *150*, then press **ENTER**.
4. Set the input voltage to 150 V.
5. Confirm that the measured values meet the specification using the table below.

Frequency	60 Hz	
Synchronization source	V 60 Hz	
order	1	
Specification	rdg [%]	0.1
	rng [%]	0.3

## 2.3 Testing Procedures

### Current Accuracy Test

3. Set the current range to 1 A.  
Press the **CURRENT** key, use the  $\wedge$  or  $\vee$  keys to select  $I$ , then press **ENTER**.
4. Set the input voltage to 150 V.
5. Confirm that the measured values meet the specification using the table below.

Frequency	60 Hz	1 kHz	10 kHz	
Synchronization source	A 60 Hz	V 50 Hz	V 400 Hz	
order	1	20	25	
Specification	rdg [%]	0.1	0.1	0.7
	rng [%]	0.3	0.4	0.5

### • Low Voltage Commands Tests

#### Connect the Protective Grounding Terminal

1. Using a digital multimeter, measure the resistance across the ground pin in the center of the inlet on the rear panel power supply connector and the mounting rack screw hole located near the side of the front panel.
2. Confirm that the measured result meets the criteria below.  
Criteria: 0.1  $\Omega$  or less.

#### Withstand Voltage Test

1. Enter settings on the withstand voltage tester as shown below.  
Voltage: 900 Vrms/2 seconds
2. Apply voltage across the input terminals all together and the output terminals all together (GP-IB/SERIAL(RS-232-C) and OUTPUT connectors).

### • Connector Cover

After all tests, close the connector covers (GP-IB/SERIAL(RS-232-C) and OUTPUT connectors).

## Settings to be Entered after Completion of Tests

When all tests have been completed, you must restore the panel settings to their initial states using one of the following two methods.

### Method 1

1. Turn the power OFF.
2. After at least one minute, turn the power **ON** while depressing **ENTER**. Continue pressing **ENTER** until the key option code appears.
3. Confirm that no error messages appear in the opening screen.

### Method 2

1. Press the **SETUP** key, use the  $\wedge$  or  $\vee$  keys to select  $P n L r S t$ , then press **ENTER**.
2. Turn the power OFF.
3. Wait at least one minute, then turn the power back ON.
4. Confirm that no error messages appear in the opening screen.

## 3.1 Operating Environment and Adjustment Equipment

### Testing Environment

Temperature:  $23 \pm 2^{\circ}\text{C}$

Humidity: 45–75% RH

Power Supply: A power supply that meets the WT210/WT230 specification.

#### **Note**

When performing adjustments, you must allow the instruments to warm up for at least 30 minutes.

### Adjustment Equipment

• Working Standard	YOKOGAWA WT210 or YOKOGAWA WT1600	1
• Current amplifier	FLUKE 5220A	1
• AC voltage generator	NF 1520	2
• AC voltage/current generator	YOKOGAWA 2558	1
• DMM	YOKOGAWA 7562	1
• Synchronizer	YOKOGAWA FG120	1
• Current amplifier*	YOKOGAWA B9295ZY	1

\* GUILDLINE 7620 or equivalent.

## 3.2 Items and Circuits to be Adjusted

### Adjustment Items

- RMS Offset Adjustment
- Voltage Range Adjustment
- Current Range Adjustment
- External Sensor Input (/EX1) Adjustment
- External Sensor Input (/EX2) Adjustment
- DA Output Adjustment

### Circuits

- Voltage input is shorted at the terminal.
- Nothing is connected to the current input terminals.
- Ext input is shorted at the terminal.

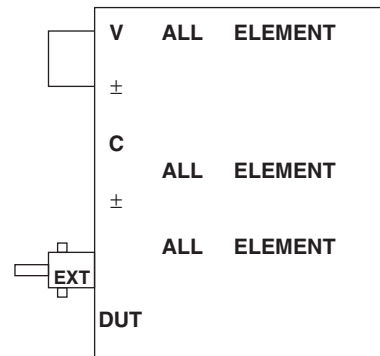

Figure 3-1 Connections for the RMS Offset Adjustment

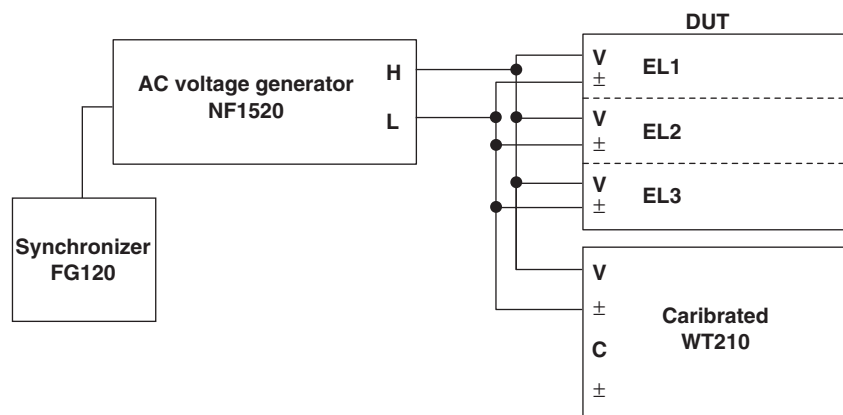

Figure 3-2 Connections for the Voltage Range Adjustment

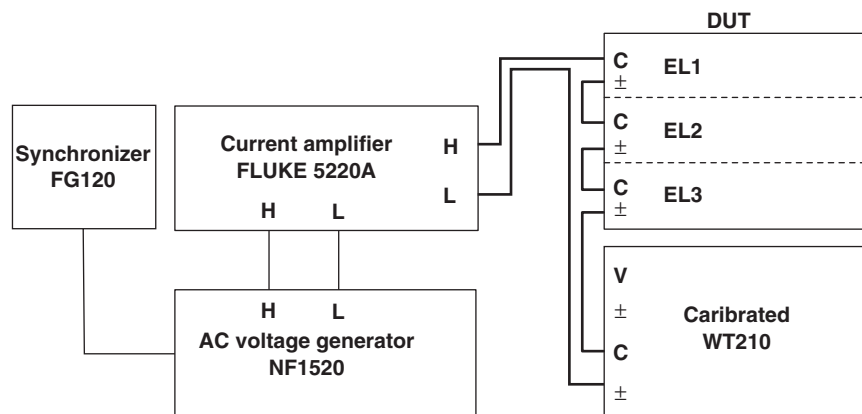

Figure 3-3 Connections for the Current Range Adjustment  $\geq 500$  mA

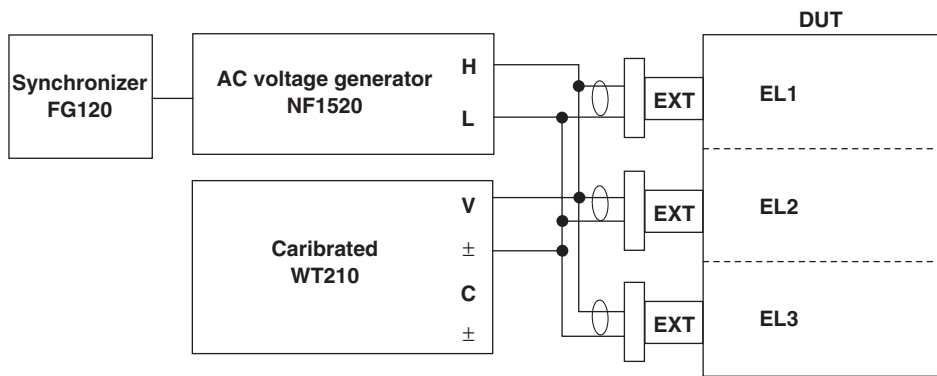

Figure 3-4 Connections for the External Sensor Input (/EX1) Adjustment

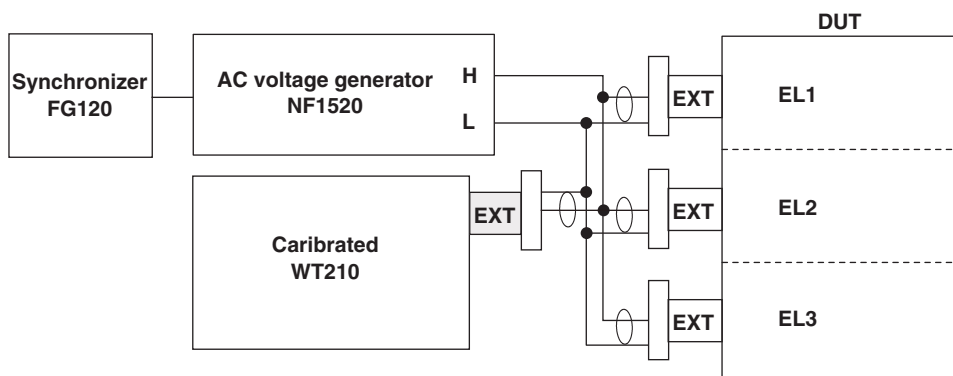

Figure 3-5 Connections for the External Sensor Input (/EX2) Adjustment

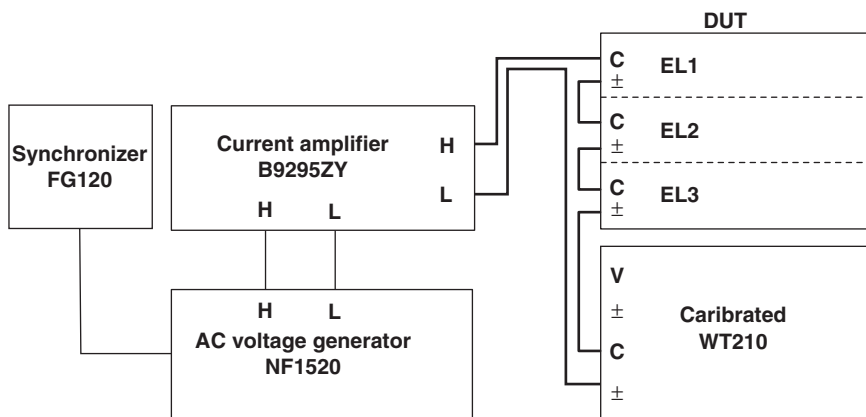

Figure 3-6 Connections for the Low Current Range Adjustment < 500 mA

## 3.3 Entering Adjustment Mode

To perform adjustments, the instrument must be in Adjustment/Test mode. The following menus are available in that mode. This chapter describes adjustments using the CAL menu.

- CAL*: Adjustment mode (RanGE, Ein, dA, End)
- TEST*: Key and LED test mode (Led, PnL, End)
- ZERo*: At startup, any residual output from the instrument of 0.5% or less of the default range is displayed as 0 on the screen. To display true value at startup, use the ZERo command. To restore the zero display, you must restart the instrument.
- RELAY*: Input Impedance testing mode (see chapter 2)
- End*: Leave Adjustment/Test mode and return to normal measurement mode.

### Note

When performing adjustments, you must allow the instruments to warm up for at least 30 minutes.

### Entering Adjustment Mode

1. Hold down the **FUNCTION B** key while turning ON the power switch. Continue to hold down the FUNCTION B key until the option code is displayed.
2. Use the  $\wedge$  or  $\vee$  keys to choose the *CAL* menu, then press **ENTER**. Adjustment mode is engaged, and the following menu appears.

Menu	Adjustment Items
<i>rRnGE</i>	Input Gain Adjustment mode
<i>Ein</i>	External Sensor Input Function Option setting or Gain Adjustment mode
<i>dA</i>	DA Option (/DA12, /DA4, /CMP) Output Adjustment mode
<i>End</i>	Deactivate adjustment mode. Return to normal measurement mode. (5 line display)

### Note

- To switch the range, press the **VOLTAGE** key to advance to the next range, or the **CURRENT** key to move to the previous range.
- When performing adjustments using communications, you can enter specific ranges.
- Press the **SHIFT** or **RESET** key to end the adjustment.
  - SHIFT: Save the adjusted value and exit.
  - RESET: Exit without saving. The adjusted value is not activated.

## 3.4 Adjustment Procedure

After entering adjustment mode, perform adjustments according to the following procedures.

### Voltage RMS Offset Adjustment

1. Connect the devices according to Figure 3-1.
2. Use the  $\wedge$  or  $\vee$  keys to select *rRnGE*, then press **ENTER**.  
 DISPLAY A: *CAL*  
 DISPLAY B: *0 F 15 V*  
 DISPLAY C: adjusted value
3. When the adjusted value becomes stable, press **ENTER**.  
 DISPLAY A: *CAL*  
 DISPLAY B: *0 F 150 V*  
 DISPLAY C: adjusted value
4. When the adjusted value becomes stable, press **ENTER**.

### Current RMS Offset Adjustment

- |  |                            |                             |
|--|----------------------------|-----------------------------|
|  | WT210 display              | WT230 display               |
|  | DISPLAY A: <i>CAL</i>      | DISPLAY A: <i>CAL</i>       |
|  | DISPLAY B: <i>0 F 5 mA</i> | DISPLAY B: <i>0 F500 mA</i> |
|  | DISPLAY C: adjusted value  | DISPLAY C: adjusted value   |
5. When the adjusted value becomes stable, press **ENTER**.  

WT210 display	WT230 display
DISPLAY A: <i>CAL</i>	DISPLAY A: <i>CAL</i>
DISPLAY B: <i>0 F50 mA</i>	DISPLAY B: <i>0 F 5 A</i>
DISPLAY C: adjusted value	DISPLAY C: adjusted value
  6. When the adjusted value becomes stable, press **ENTER**. For the WT230, skip to step 9.  

WT210 display	
DISPLAY A: <i>CAL</i>	
DISPLAY B: <i>0 F500 mA</i>	
DISPLAY C: adjusted value	
  7. When the adjusted value becomes stable, press **ENTER**.  

WT210 display	
DISPLAY A: <i>CAL</i>	
DISPLAY B: <i>0 F 5 A</i>	
DISPLAY C: adjusted value	
  8. When the adjusted value becomes stable, press **ENTER**.

### Range Full Scale Adjustment

#### Voltage Range Adjustment

- |  |                           |
|--|---------------------------|
|  | DISPLAY A: <i>CAL</i>     |
|  | DISPLAY B: <i>15.00 V</i> |
|  | DISPLAY C: adjusted value |
9. Connect the devices according to Figure 3-2.
  10. Input a signal of 15 V/60 Hz.
  11. When the adjusted value becomes stable, press **ENTER**.  

DISPLAY A: <i>CAL</i>
DISPLAY B: <i>30.00 V</i>
DISPLAY C: adjusted value

### 3.4 Adjustment Procedure

---

12. Input a signal of 30 V/60 Hz.  
Set the output from the AC voltage generator so that it matches the calibration value for 30 V/60 Hz on the display of the working standard.
13. When the adjusted value becomes stable, press **ENTER**.  
DISPLAY A:  $\overline{RL}$   
DISPLAY B: 60.00 V  
DISPLAY C: adjusted value
14. Input a signal of 60 V/60 Hz.  
Set the output from the AC voltage generator so that it matches the calibration value for 60 V/60 Hz on the display of the working standard.  
DISPLAY A:  $\overline{RL}$   
DISPLAY B: 150.0 V  
DISPLAY C: adjusted value
15. Input a signal of 150 V/60 Hz.  
Set the output from the AC voltage generator so that it matches the calibration value for 150 V/60 Hz on the display of the working standard.
16. When the adjusted value becomes stable, press **ENTER**.  
DISPLAY A:  $\overline{RL}$   
DISPLAY B: F 150.0 V  
DISPLAY C: adjusted value

#### Voltage Line Filter Adjustment

17. Input a signal of 150 V/60 Hz.
18. When the adjusted value becomes stable, press **ENTER**. For WT230, skip to step 22.  
WT210 display  
DISPLAY A:  $\overline{RL}$   
DISPLAY B: 100.0 mA  
DISPLAY C: adjusted value

#### Current Range Adjustment

19. Connect the devices according to Figure 3-6.
20. Input a signal of 100 mA/60 Hz.  
Set the output from the AC voltage generator so that it matches the calibration value for 100 mA/60 Hz on the display of the working standard.
21. When the adjusted value becomes stable, press **ENTER**.  
DISPLAY A:  $\overline{RL}$   
DISPLAY B: 500.0 mA  
DISPLAY C: adjusted value
22. Connect the devices according to Figure 3-3.
23. Input a signal of 500 mA/60 Hz.  
Set the output from the AC voltage generator so that it matches the calibration value for 500 mA/60 Hz on the display of the working standard.
24. When the adjusted value becomes stable, press **ENTER**.  
DISPLAY A:  $\overline{RL}$   
DISPLAY B: 1.000 A  
DISPLAY C: adjusted value
25. Input a signal of 1 A/60 Hz.  
Set the output from the AC voltage generator so that it matches the calibration value for 1 A/60 Hz on the display of the working standard.

26. When the adjusted value becomes stable, press **ENTER**.  
 DISPLAY A: *CAL*  
 DISPLAY B: *2.000* A  
 DISPLAY C: adjusted value
27. Input a signal of 2 A/60 Hz.  
 Set the output from the AC voltage generator so that it matches the calibration value for 2 A/60 Hz on the display of the working standard.
28. When the adjusted value becomes stable, press **ENTER**.  
 DISPLAY A: *CAL*  
 DISPLAY B: *5.000* A  
 DISPLAY C: adjusted value
29. Input a signal of 5 A/60 Hz.  
 Set the output from the AC voltage generator so that it matches the calibration value for 5 A/60 Hz on the display of the working standard.
30. When the adjusted value becomes stable, press **ENTER**.

**Current Line Filter Adjustment**

- DISPLAY A: *CAL*  
 DISPLAY B: *F 1.000* A  
 DISPLAY C: adjusted value
31. Input a signal of 1 A/60 Hz.  
 Set the output from the AC voltage generator so that it matches the calibration value for 1 A/60 Hz on the display of the working standard.
  32. When the adjusted value becomes stable, press **ENTER**.
  33. Press **SHIFT** or **RESET**.  
 Press **SHIFT**. The adjusted value is saved to the EEPROM.  
 Press the **RESET** exit without saving.

**External Sensor Input Range Adjustment (Only If the /EX1 or /EX2 Option Is Installed)****RMS Offset Adjustment**

1. Connect the devices according to Figure 3-1.
2. Use the  $\wedge$  or  $\vee$  keys to select  $E-1$ , then press **ENTER**.
3. Use the  $\wedge$  or  $\vee$  keys to select  $E-1$  or  $E-2$ , then press **ENTER**.
 

<b>If <math>E-1</math> Is Selected</b>	<b>If <math>E-2</math> Is Selected</b>
DISPLAY A: <i>CAL</i>	DISPLAY A: <i>CAL</i>
DISPLAY B: <i>0FE2.5</i> V	DISPLAY B: <i>0FE50</i> mV
DISPLAY C: adjusted value	DISPLAY C: adjusted value
4. When the adjusted value becomes stable, press **ENTER**.
 

<b>If <math>E-1</math> Is Selected</b>	<b>If <math>E-2</math> Is Selected</b>
DISPLAY A: <i>CAL</i>	DISPLAY A: <i>CAL</i>
DISPLAY B: <i>E 10.00</i> V	DISPLAY B: <i>E200.0</i> mV
DISPLAY C: adjusted value	DISPLAY C: adjusted value

**Range Full Scale Adjustment**

5. Connect the devices according to Figure 3-4 for the /EX1 option, or Figure 3-5 for the /EX2 option.
6. Input a signal of **10 V/60 Hz** for  $E-1$ , or **200 mV/60 Hz** for  $E-2$ .  
 Set the output from the AC voltage generator so that it matches the calibration value on the display of the working standard.
7. When the adjusted value becomes stable, press **ENTER**.
8. Press **SHIFT** or **RESET**.  
 Press the **SHIFT** key save the adjusted value to the EEPROM.  
 Press the **RESET** exit without saving.

#### DA Output Adjustment (Only If the /DA12 or /DA4 or /CMP Option Is Installed)

A connector is required for connecting the pins from each DA output channel on the external I/O connector on the rear panel to the digital multimeter. See IM section 9.1 of IM 760401-01E for the relationship between the output signals and the connector pins.

1. Enter Adjustment mode (see section 3.3, "Entering Adjustment Mode").
2. Use the  $\wedge$  or  $\vee$  key to select *dR*, then press **ENTER**.
3. Connect the CH1 and DA COM connectors on the rear panel of the external I/O connector to the digital multimeter.
4. Use the  $\wedge$  or  $\vee$  keys to select *Ch 1* on DISPLAY A, then press **ENTER**.  
DISPLAY A: ch1  
DISPLAY B: 5.000  
DISPLAY C: 5.0000
5. A voltage of +5 will be output automatically, so when the designated value on the digital multimeter stabilizes, use the  $\wedge$ ,  $\vee$ , or  $>$  keys to set the value for DISPLAY C to the that designated value, and then press **ENTER**.  
DISPLAY A: *Ch 1*  
DISPLAY B: *-5.000*  
DISPLAY C: *-5.0000*
6. A voltage of -5 will be output automatically, so just as in the previous step, when the designated value on the digital multimeter stabilizes, use the  $\wedge$ ,  $\vee$ , or  $>$  keys to set the value for DISPLAY C to the that designated value, and then press **ENTER**. DISPLAY A switches to the following channel.  
Repeat steps 5-6 and adjust all channels. When you are finished adjusting the last channel and press ENTER, *Ch 1* appears in DISPLAY B.
7. Press the **SHIFT** key. The instrument returns to adjustment mode.  
DISPLAY C: *dR*
8. Use the  $\wedge$  or  $\vee$  keys to select *End*, then press **ENTER**. The instrument returns to normal measurement mode.  
DISPLAY C: *RL*

## 3.5 Communications Commands

### Commands for Range Adjustment Mode

Command	Function
CAL1	Range Adjustment mode
CR0	15 V range adjustment
CR1	30 V range adjustment
CR2	60 V range adjustment
CR3	150 V range adjustment
CR4	100 mA range adjustment
CR5	500 mA range adjustment
CR6	1 A range adjustment
CR7	2 A range adjustment
CR8	5 A range adjustment
CR11	Voltage range line filter adjustment(150 V)
CR12	Current range line filter adjustment(1 A)
CR13	Voltage RMS value offset adjustment (15 V)
CR14	Voltage RMS value offset adjustment (150 V)
CR15	Current RMS value offset adjustment (5 mA)
CR16	Current RMS value offset adjustment (50 mA)
CR17	Current RMS value offset adjustment (500 mA)
CR18	Current RMS value offset adjustment (5 A)
ENT	FS value entry: Exit range adjustment mode
END	End adjustments(write changes to EEPROM)
CAN	End adjustments(do not write changes to EEPROM)
CAL2	Current external voltage input range adjustment mode
EX0	No options
EX1	/EX1 (2.5, 5/10 V)
EX2	/EX2 (50 m/100 m/200 mV)
CR9	/EX2 range adjustment (200 mV)
CR10	/EX1 range adjustment (10 V)
EX19	/EX2 RMS value offset adjustment (50 mV)
CR20	/EX1 RMS value offset adjustment (2.5 V)
ENT	FS value entry: Exit current external voltage input range adjustment mode
END	End adjustments (write changes to EEPROM)
CAN	End adjustments (do not write changes to EEPROM)
CAL3	Analog output adjustment mode.
DO0	Channel under adjustment outputs +5 V
DO1	Channel under adjustment outputs -5 V output
CDm, n	Save actually output value, but do not update calibrated settings. m: channel number n: actual output value
CHm	Adjust channel m m: channel number
ENT	Save actually output value, and update calibrated settings.
END	End adjustments (write changes to EEPROM)
CAN	End adjustments (do not write changes to EEPROM)
CAL4	Enter zero mode.
CAL0	Exit adjust/test mode. Return to normal mode.

### Maintenance Commands

m: address n: data

Command	Function
RB m	Read number of bytes in memory.
RW m	Read number of words in memory.
RL m	Read number of long words in memory.
WB m,n	Write number of bytes in memory.
WW m,n	Write number of words in memory.
WL m,n	Write number of long words in memory.

## 4.1 Flow Chart

This chapter describes possible solutions for rectifying errors. Errors occur, assembly removal may be required.

---

### WARNING

Assembly replacement is to be performed only by qualified service technicians who have experience working with the hazards involved (such as fire and electrical shock).

---

### Note

If an error message is displayed, the error may have been caused by incorrectly operating the unit. Refer to the user's manual, and perform the correct operation.

---

4.1 Flow Chart

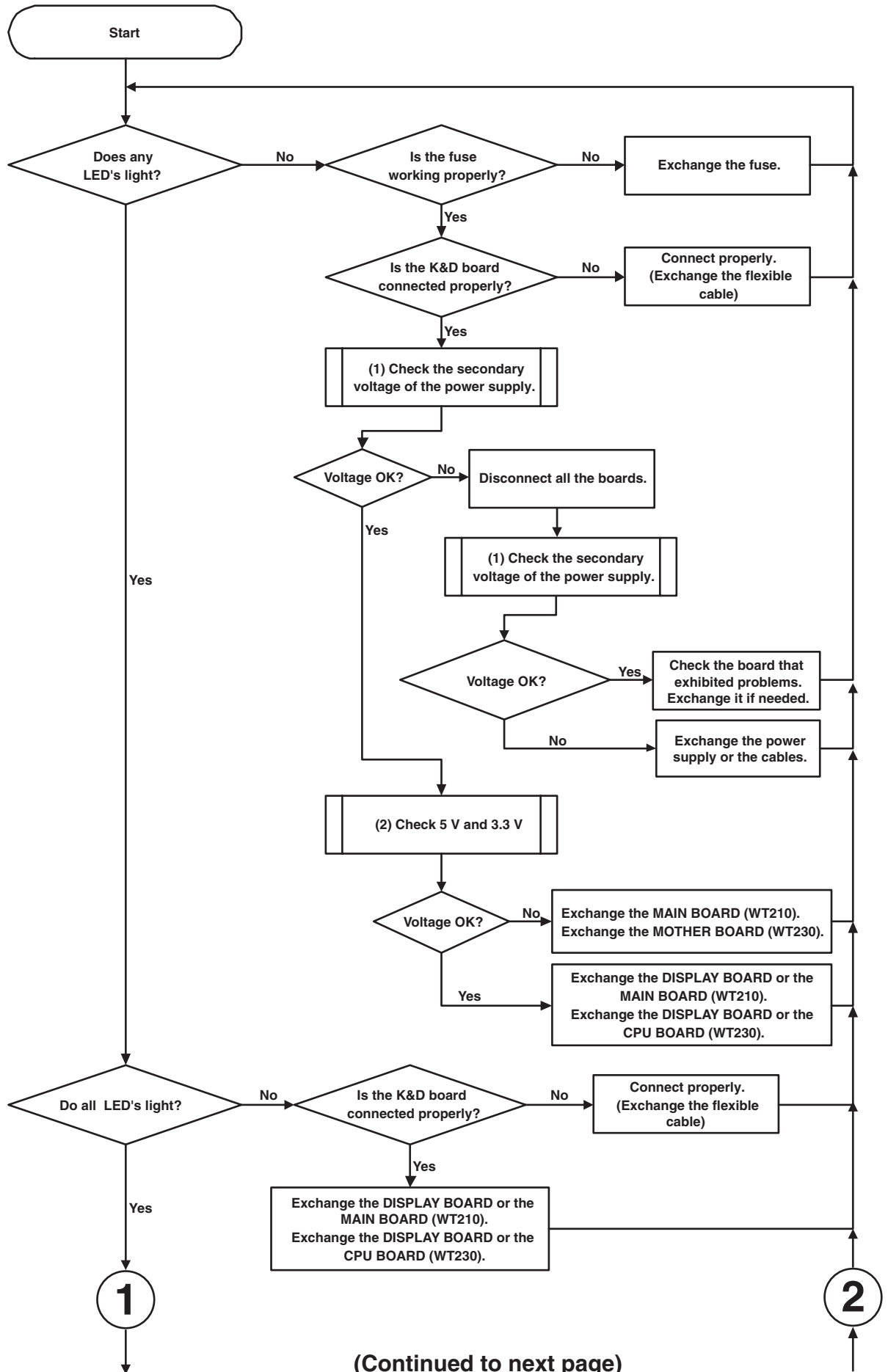

(Continued to next page)

(Continued from the previous page)

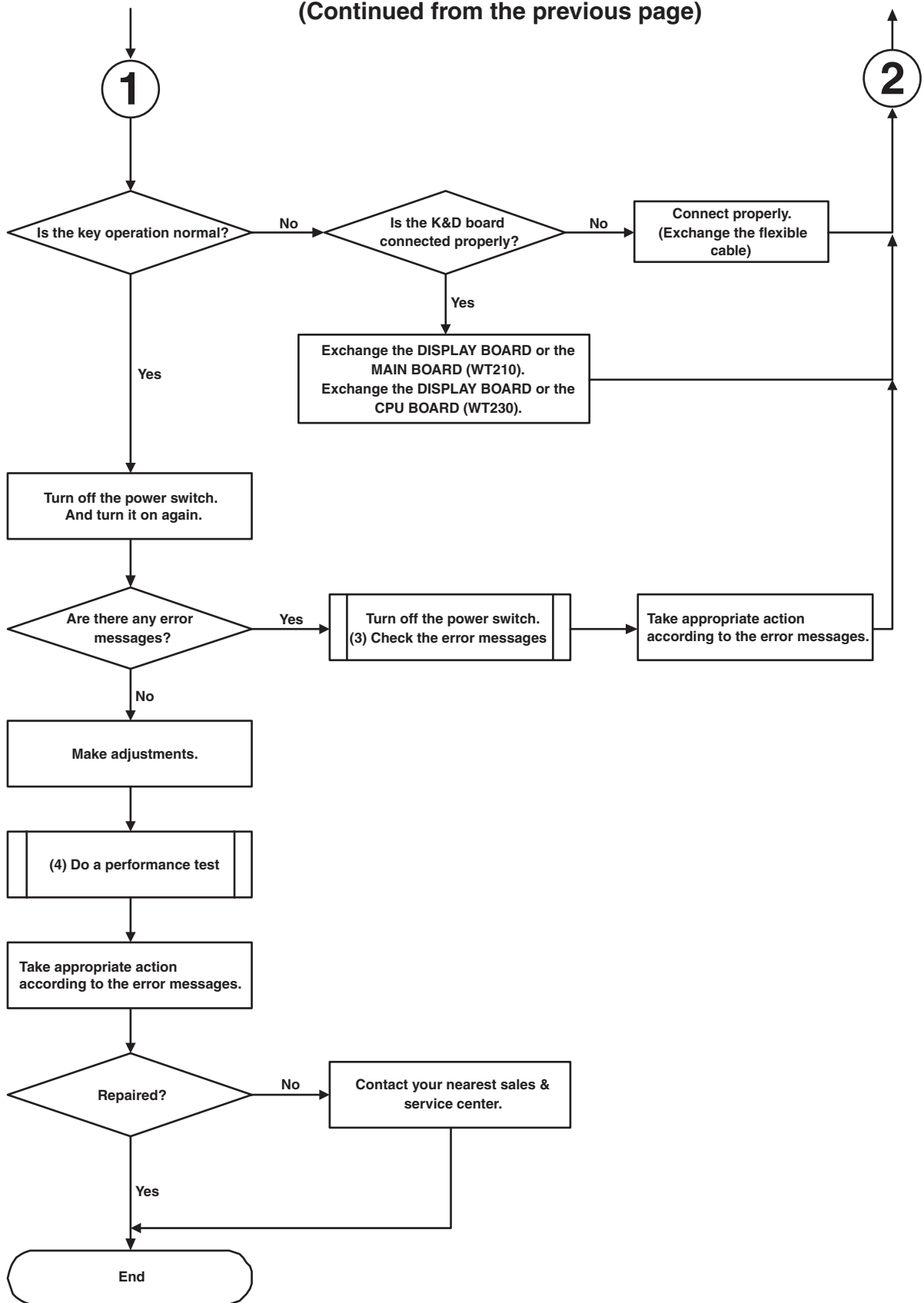

## 4.2 Confirming Results

### (1) Checking the secondary voltage of the power supply.

Use a tester to confirm the voltages of the following terminals.

Be sure to connect the COM terminal of the tester to the case of the unit.

	Assembly Name	Assembly No.	Item No.	Pin No.	Voltage value		
					min	typ	max
WT210	MAIN BOARD ASSY	B9317PK/PL/PM	CN709	1, 2	23.0 V	24.0 V	25.0 V
WT230	MOTHER BOARD ASSY	B9317PC	CN9	3, 4	4.9 V	5.0 V	5.3 V
	(or) CPU BOARD ASSY	B9317PB	C8	2	4.9 V	5.0 V	5.3 V

### (2) Checking 5 V and 3.3 V

Use a tester to confirm the voltages of the following terminals.

Be sure to connect the COM terminal of the tester to the case of the unit.

	Assembly Name	Assembly No.	Item No.	Pin No.	Voltage value		
					min	typ	max
WT210	MAIN BOARD ASSY	B9317PK/PL/PM	U751	2 (connects D751)	4.7 V	5.0 V	5.4 V
	MAIN BOARD ASSY	B9317PK/PL/PM	U752	2 (center pin)	3.2 V	3.3 V	3.4 V
WT230	MOTHER BOARD ASSY	B9317PC	U1	2 (center pin)	3.2 V	3.3 V	3.4 V
	(or) CPU BOARD ASSY	B9317PB	C214	2	3.2 V	3.3 V	3.4 V

### (3) Checking error messages

Code	Message	WT210		WT230	
		Assembly Name	Assembly No.	Assembly Name	Assembly No.
60	Data failure of setup parameters backup.	MAIN BOARD ASSY	B9317PK/PL/PM	CPU BOARD ASSY	B9317PB
61	EEPROM (element1) failure.	MAIN BOARD ASSY	B9317PK/PL/PM	INPUT BOARD ASSY	B9317PA
62	EEPROM (element2) failure.	MAIN BOARD ASSY	B9317PK/PL/PM	INPUT BOARD ASSY	B9317PA
63	EEPROM (element3) failure.	MAIN BOARD ASSY	B9317PK/PL/PM	INPUT BOARD ASSY	B9317PA
64	EEPROM (D/A board) failure.	DA4CH/CMP BOARD ASSY	B9317PP/PQ	DA12CH/CMP BOARD ASSY	B9317PG/PH
68	Data file failure.	MAIN BOARD ASSY	B9317PK/PL/PM	CPU BOARD ASSY	B9317PB
71	DSP communication failure.	MAIN BOARD ASSY	B9317PK/PL/PM	CPU BOARD ASSY	B9317PB
72	DSP communication failure.	MAIN BOARD ASSY	B9317PK/PL/PM	CPU BOARD ASSY	B9317PB
73	DSP communication failure.	MAIN BOARD ASSY	B9317PK/PL/PM	CPU BOARD ASSY	B9317PB
75	Internal DSP error.	MAIN BOARD ASSY	B9317PK/PL/PM	CPU BOARD ASSY	B9317PB
78	Backup data failure in setup parameters.	MAIN BOARD ASSY	B9317PK/PL/PM	CPU BOARD ASSY	B9317PB
79	ROM checksum error.	MAIN BOARD ASSY	B9317PK/PL/PM	CPU BOARD ASSY	B9317PB
80	RAM read/write check error.	MAIN BOARD ASSY	B9317PK/PL/PM	CPU BOARD ASSY	B9317PB
81	RAM failure on the harmonics board.	HARM BOARD ASSY	B9317PR	HARM BOARD ASSY	B9317PR

Code	Message	WT210		WT230	
		Assembly Name	Assembly No.	Assembly Name	Assembly No.
84	DSP sample clock failure.	MAIN BOARD ASSY	B9317PK/PL/PM	CPU BOARD ASSY	B9317PB
90	Incorrect board combination.	MAIN BOARD ASSY	B9317PK/PL/PM	INPUT BOARD ASSY	B9317PA
91	Incorrect board combination.	MAIN BOARD ASSY	B9317PK/PL/PM	INPUT BOARD ASSY	B9317PA

\* Redundancy is provided for EEPROMs that handle errors 61, 62, and 63. If one of the errors (61, 62, or 63) appears when the instrument is turned ON, turn OFF the instrument and turn it back ON again. If no errors occur on the second attempt, servicing is not necessary.

\*\* A lithium battery is used to retain the setup parameters. If the lithium battery is low, error codes 60, 68, and 78 appear when the power switch is turned ON. Battery is on MAIN BOARD ASSY B9317PK/PL/PM(WT210), and MOTHER BOARD ASSY B9317PC(WT230)

#### (4) Doing a performance test

	WT210		WT230	
	Assembly Name	Assembly No.	Assembly Name	Assembly No.
Over Range Input	MAIN BOARD ASSY	B9317PK/PL/PM	INPUT BOARD ASSY	B9317PA
AutoRange, Peak/Range Over	MAIN BOARD ASSY	B9317PK/PL/PM	INPUT BOARD ASSY	B9317PA
			CPU BOARD ASSY	B9317PB
Communication	MAIN BOARD ASSY	B9317PK/PL/PM	GP-IB/RS-232-C PANEL ASSY	B9317GM/GP
			CPU BOARD ASSY	B9317PB
Remote Control	DA4CH/CMP BOARD ASSY	B9317PP/PQ	DA12CH/CMP BOARD ASSY	B9317PG/PH
	MAIN BOARD ASSY	B9317PK/PL/PM	CPU BOARD ASSY	B9317PB
LINE FILTER	MAIN BOARD ASSY	B9317PK/PL/PM	INPUT BOARD ASSY	B9317PA
Integrate Wh, Ah	MAIN BOARD ASSY	B9317PK/PL/PM	INPUT BOARD ASSY	B9317PA
Frequency Measurement	MAIN BOARD ASSY	B9317PK/PL/PM	INPUT BOARD ASSY	B9317PA
			CPU BOARD ASSY	B9317PB
Phase Lead/ Lag Test	MAIN BOARD ASSY	B9317PK/PL/PM	INPUT BOARD ASSY	B9317PA
			CPU BOARD ASSY	B9317PB
D/A output	DA4CH/CMP BOARD ASSY	B9317PP/PQ	DA12CH/CMP BOARD ASSY	B9317PG/PH
	MAIN BOARD ASSY	B9317PK/PL/PM	CPU BOARD ASSY	B9317PB
Linearity	MAIN BOARD ASSY	B9317PK/PL/PM	INPUT BOARD ASSY	B9317PA
Zero Power Factor	MAIN BOARD ASSY	B9317PK/PL/PM	INPUT BOARD ASSY	B9317PA
	HARM BOARD ASSY	B9317PR	HARM BOARD ASSY	B9317PR
Harmonic Analysis	MAIN BOARD ASSY	B9317PK/PL/PM	CPU BOARD ASSY	B9317PB
			INPUT BOARD ASSY	B9317PA

# 5.1 Schematic Diagram

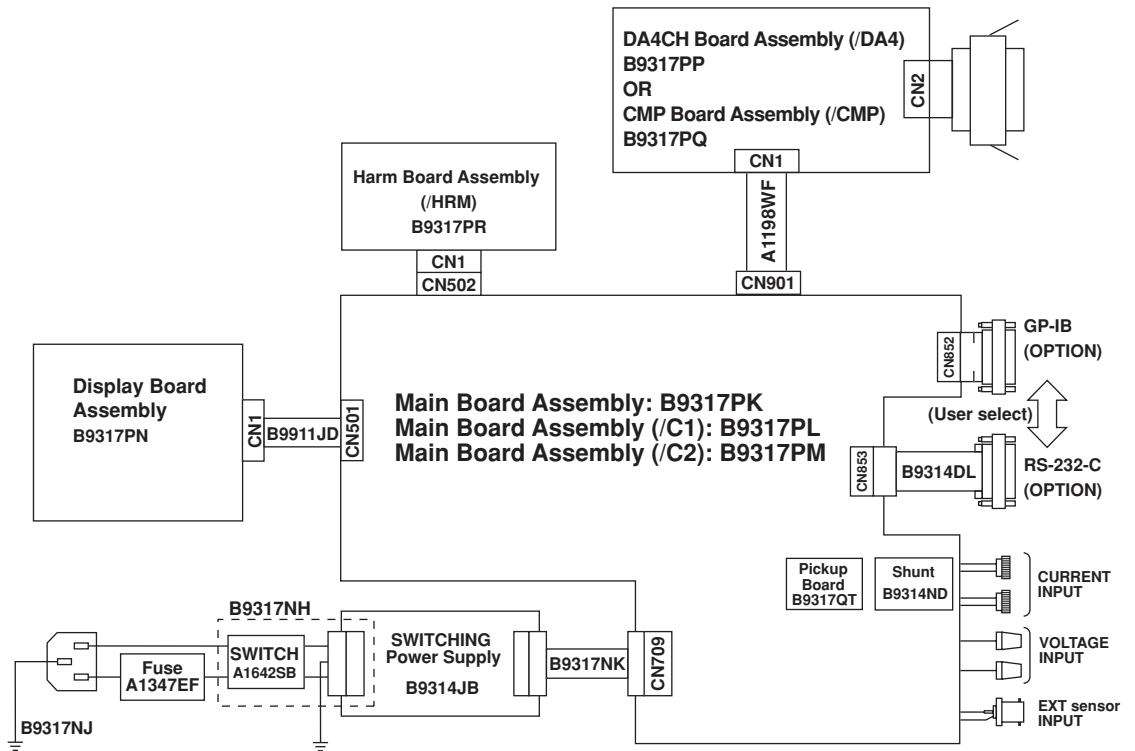

Figure 5.1 Schematic Diagram of the WT210

## 5.1 Schematic Diagram

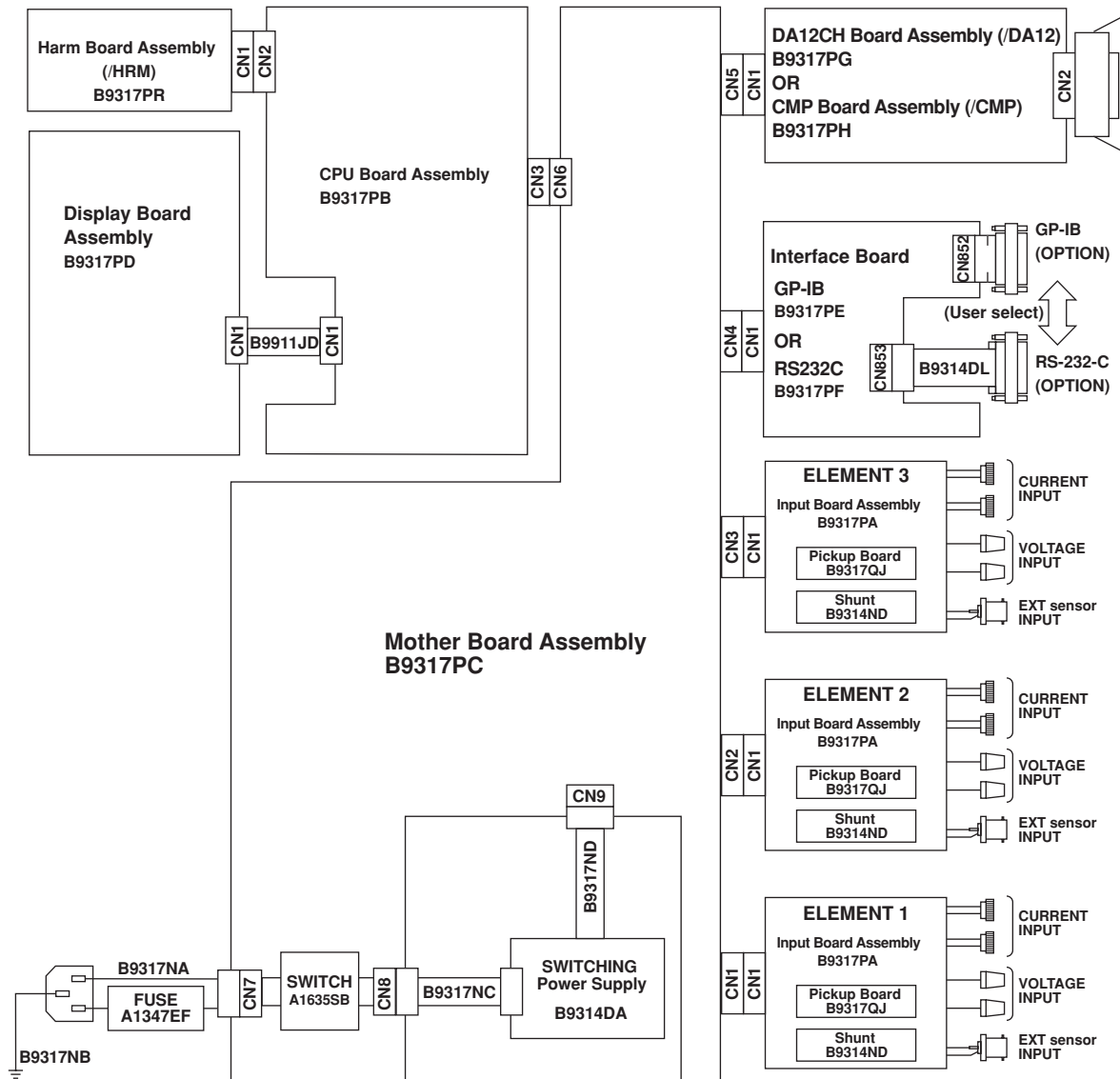
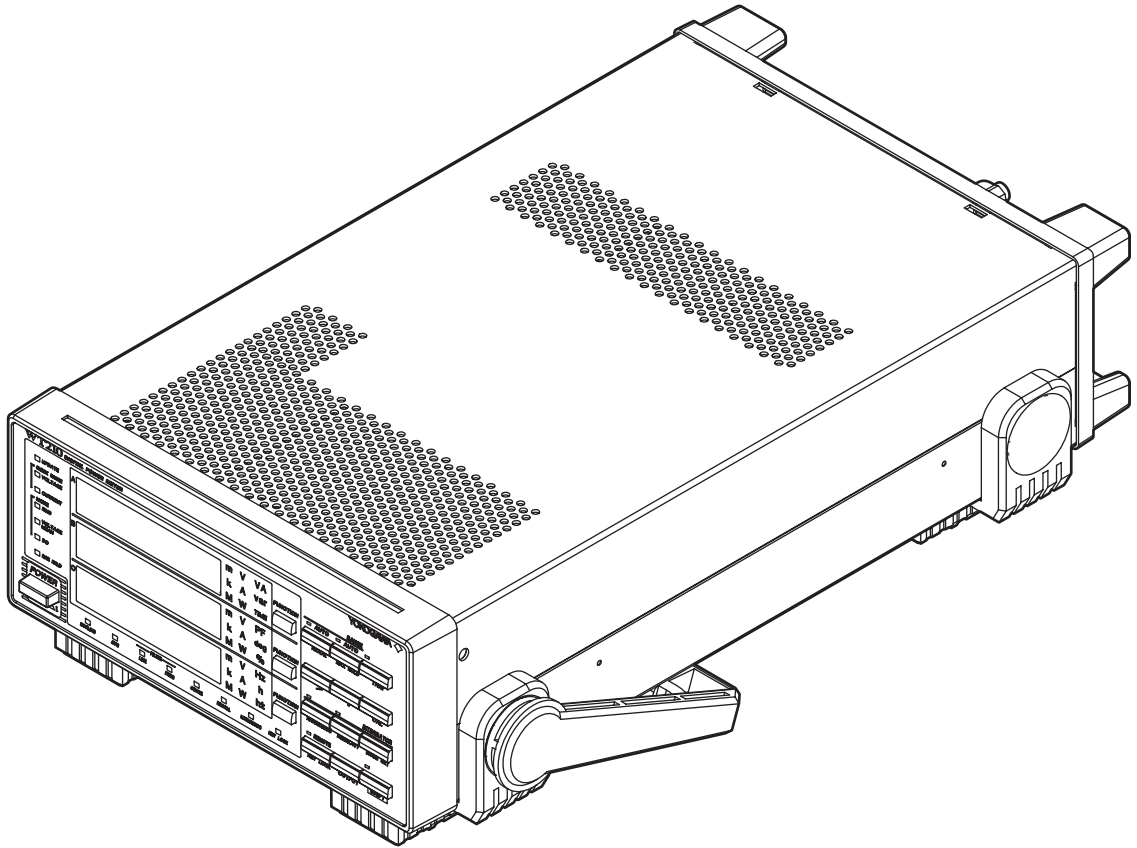

Figure 5.2 Schematic Diagram of the WT230

## 6.1 WT210 Customer Maintenance Parts List



**Note:**

Parts marked with a  $\odot$  symbol are CMPL (Customer Maintenance Parts List) parts.



6.1 Customer Maintenance Parts List

Item	Part No.	Qty	Description
1	B9317CA	1	Front Panel Assembly
⊙ 2	B9317CE	1	Front Sheet
3	B9317CB	1	Front Panel
4	B9314LZ	6	LED Cover
5	B9314CP	4	Stud
6	B9317PN	1	Display Board Assembly
7	Y9310LB	4	B.H. Screw, M3x10
8	B9314LY	3	LED Cover
9	B9314KW	3	Knob
10	B9317CC	1	Knob
⊙ 11	Y9405LB	4	B.H. Screw, M4x5
⊙ 12	A9119ZM	1	Grip
⊙ 13	A9118ZM	2	Foot
⊙ 14	A9070ZB	2	Sheet
15	A9112ZM	1	Front Bezel
16	B9317PQ	1	CMP Board Assembly (/CMP)
	B9317PP	1	DA4CH Board Assembly (/DA4)
17	B9317BH	1	Rear Sheet
18	A1411EF	1	Inlet
19	B9317PK	1	Main Board Assembly (not /C1, /C2)
	B9317PL	1	Main Board Assembly (/C1)
	B9317PM	1	Main Board Assembly (/C2)
20	B9317CG	1	Input Assembly
21	B9317CM	2	Shield Case
22	B9317CL	2	Shield Case
23	B9317QT	1	Pickup Board Assembly
24	B9317QU	1	Spacer Board Assembly
25	B9317ZA	2	Relay
26	B9317BR	1	Panel Assembly
27	B9317BW	1	Terminal
28	B9317BS	1	Panel Assembly
29	B9317BV	1	Terminal
⊙ 30	B9293DE	2	Knob Assembly
31	Y9601CB	6	Nut
32	A1618HE	2	Zener Diode
33	Y9600WB	2	Washer
34	Y9600SP	2	Washer
53	B9284LZ	1	BNC Connector (/EX1, /EX2)
54	B9317NM	1	Cable Assembly (/EX1, /EX2)
55	B9284HM	1	Sheet (not /EX1, /EX2)
35	B9314LP	1	Shunt Assembly
36	B9293DL	1	Block
37	Y9306TS	2	Screw, Tapping
38	B9314ND	1	Shunt
⊙ 39	B9317CY	1	Terminal Cover Assembly
⊙ 40	B9314CX	1	Cap Assembly (/C1)
	B9314CZ	1	Cap Assembly (/C2)
⊙ 41	B9314CY	1	Cap Assembly (/CMP, /DA4)
⊙ 42	A9113ZM	1	Rear Bezel
43	B9317BM	1	Cover Assembly
⊙ 44	A9069ZB	4	Sheet
45	B9911JD	1	Cable Assembly
46	B9317NH	1	Power Switch Assembly
47	B9317PR	1	Harm Board Assembly (/HRM)
48	B9589XJ	4	Spacer (/HRM)
49	B9314JB	1	Switching Power
50	B9317BJ	1	Switch Lever
51	Y9250ET	1	E-Ring
⊙ 52	A9102ZG	1	Switch Knob
⊙ 56	A1347EF	2	Fuse (see page 6-4)

Note:  
 ⊙ CMPL Parts

## 6.2 WT210 Standard Accessories

### Standard Accessories

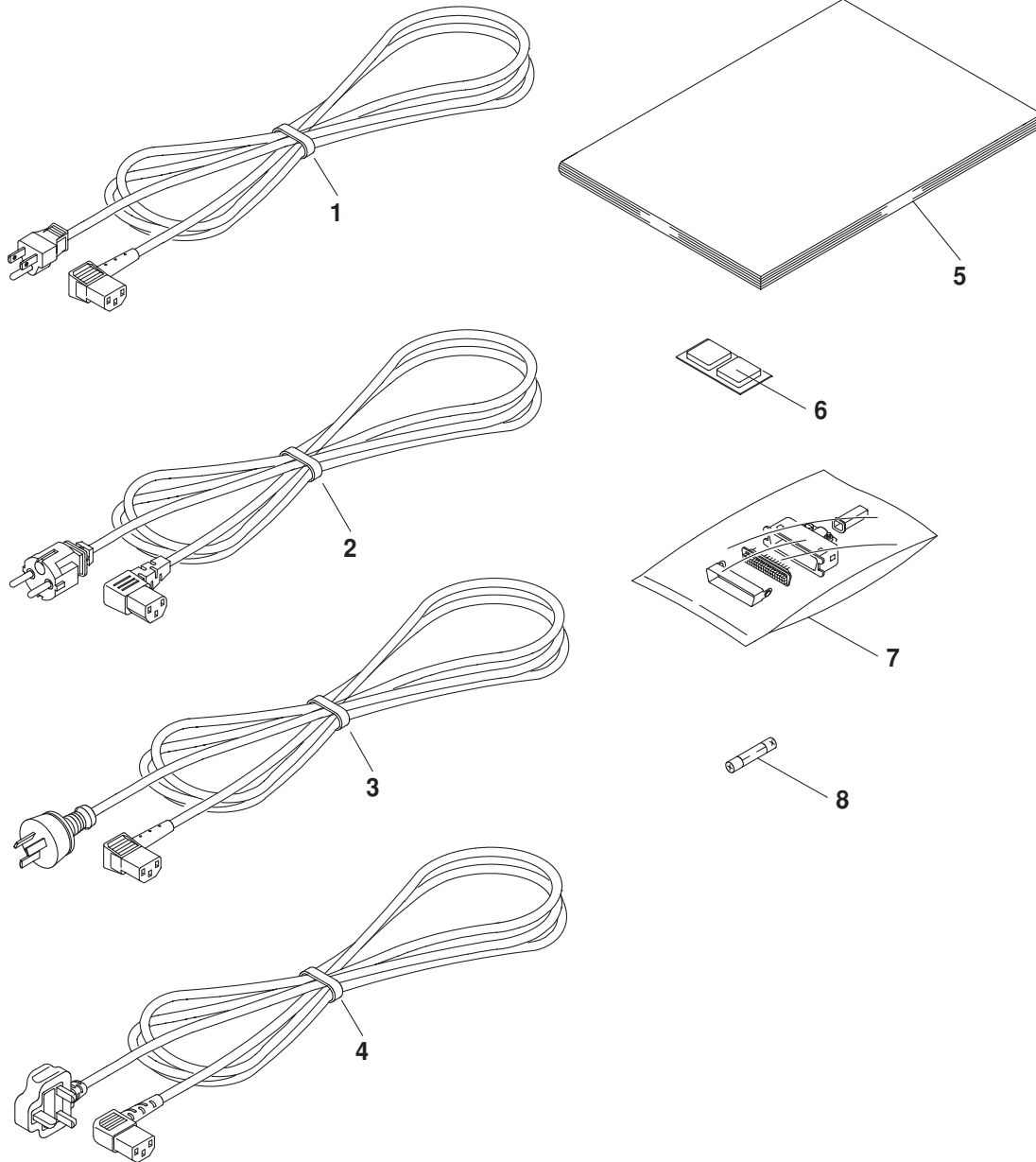

Item	Part No.	Qty	Description
⊙ 1	A1006WD	1	Power Supply Code (UL/CSA Standard) *
⊙ 2	A1009WD	1	Power Supply Code (VDE Standard) †
⊙ 3	A1054WD	1	Power Supply Code (BS Standard) ‡
⊙ 4	A1024WD	1	Power Supply Code (AS Standard) §
5	IM 760401-01E	1	WT210/WT230 Digital Power Meter User's Manual
⊙ 6	A9088ZM	1	Stopper
⊙ 7	A1004JD	1	Cable Connector (/CMP, /DA4)
⊙ 8	A1347EF	1	Fuse (see page 6-2)

Note:

- \* 760401 - □-D
- † 760401 - □-F
- ‡ 760401 - □-Q
- § 760401 - □-R
- ⊙ CMPL Parts



6.3 WT230 Customer Maintenance Parts List

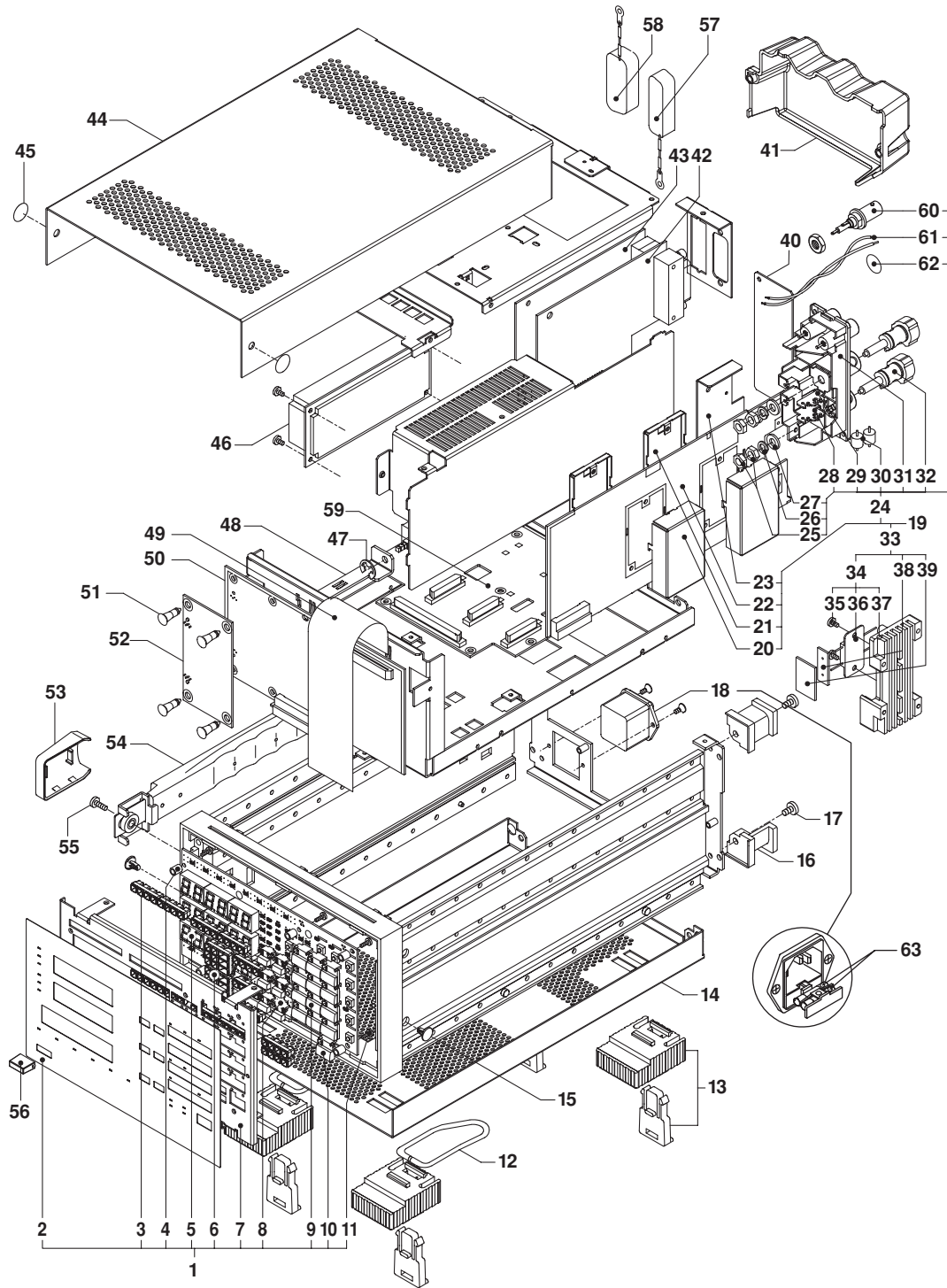

Item	Part No.	Qty	Description
1	B9317GA	1	Front Panel Assembly
⊙ 2	B9317GF	1	Front Sheet
3	B9314LZ	13	LED Cover
4	B9314CP	6	Stud
5	B9317PD	1	Display Board Assembly
6	B9314LY	3	LED Cover
7	B9317GB	1	Front Panel
8	B9314KX	3	Knob
9	B9317GC	1	Knob
10	B9317GD	1	Knob
11	Y9310LB	6	B.H. Screw, M3x10
⊙ 12	A9086ZM	2	Support
⊙ 13	A9120ZM	4	Foot Assembly
14	B9317FD	1	Bottom Cover
⊙ 15	A9068ZB	2	Cap
⊙ 16	A9085ZM	4	Foot
⊙ 17	Y9408LB	4	B.H. Screw, M4x8
18	A1360JS	1	Socket and Holder
19	B9317HA	3	Input Assembly (760503)
	B9317HA	2	Input Assembly (760502)
			} (select)
20	B9317CL	2	Shield Case
21	B9317CM	2	Shield Case
22	B9317PA	1	Input Board Assembly
23	B9317HB	1	Bracket
24	B9317HC	1	Panel Assembly
25	Y9601CB	6	Nut
26	Y9600WB	2	Washer
27	Y9600SP	2	Washer
28	B9317HE	1	Terminal
29	B9317HD	1	Terminal
30	A1618HE	2	Zener Diode
31	B9317HL	1	Panel Assembly
⊙ 32	B9293DE	2	Knob Assembly
60	B9284LZ	2	BNC Connector (760502 /EX1, /EX2)
	B9284LZ	3	BNC Connector (760503 /EX1, /EX2)
			} (select)
61	B9317NF	2	Cable Assembly (760502 /EX1, /EX2)
	B9317NF	3	Cable Assembly (760502 /EX1, /EX2)
62	B9284HM	2	Sheet (not /EX1, /EX2)
	B9284HM	3	Sheet (not /EX1, /EX2)
			} (select)
33	B9317HG	1	Shunt Assembly
34	B9314LP	1	Shunt Assembly
35	Y9306TS	2	Screw, Tapping
36	B9314ND	1	Shunt
37	B9293DL	1	Block
38	B9317QS	1	Spacer Board Assembly
39	B9317QJ	1	Pickup Board Assembly
40	B9317HH	1	Panel (760502)
⊙ 41	B9317GY	1	Terminal Cover Assembly
42	B9317GM	1	GP-IB Panel Assembly (-C1)
	B9317GP	1	RS-232-C Panel Assembly (-C2)
			} (select)
43	B9317PG	1	DA12CH Board Assembly (/DA12)
	B9317PH	1	CMP Board Assembly (/CMP)
			} (select)
44	B9317FC	1	Top Cover
⊙ 45	A9069ZB	2	Sheet
46	B9314DA	1	Power Supply
47	Y9250ET	1	E-Ring
48	B9317FH	1	Switch Lever
49	B9911JD	1	Cable Assembly
50	B9317PB	1	CPU Board Assembly
51	B9589XJ	4	Spacer (/HRM)
52	B9317PR	1	Harm Board Assembly (/HRM)
⊙ 53	A9065ZM	2	Cover
⊙ 54	B9919CV	1	Grip Assembly
⊙ 55	Y9514LS	2	B.H. Screw, M5x14
⊙ 56	A9102ZG	1	Switch Knob
⊙ 57	B9314CX	1	Cap Assembly (-C1)
	B9314CZ	1	Cap Assembly (-C2)
			} (select)
⊙ 58	B9314CY	1	Cap Assembly (/CMP, /DA12)
59	B9317PC	1	Mother Board Assembly
⊙ 63	A1347EF	2	Fuse (see page 6-8)

Note:

⊙ CMPL Parts

## 6.4 WT230 Standard Accessories

### Standard Accessories

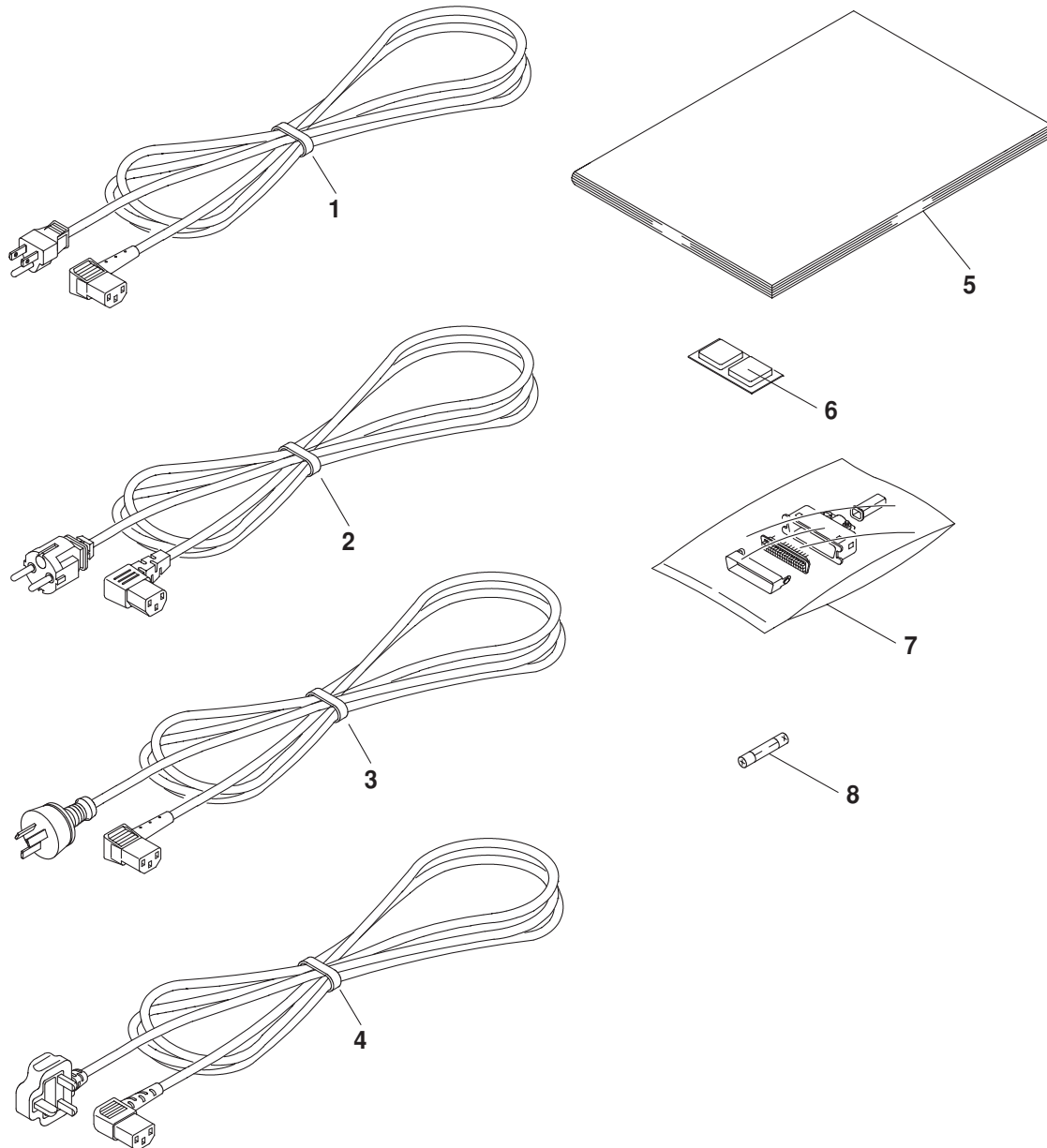

Item	Part No.	Qty	Description
⊙ 1	A1006WD	1	Power Supply Code (UL/CSA Standard) *
⊙ 2	A1009WD	1	Power Supply Code (VDE Standard) †
⊙ 3	A1054WD	1	Power Supply Code (BS Standard) ‡
⊙ 4	A1024WD	1	Power Supply Code (AS Standard) §
5	IM 760401-01E	1	WT210/WT230 Digital Power Meter User's Manual
⊙ 6	A9088ZM	1	Stopper
⊙ 7	A1004JD	1	Cable Connector (/C/M, /DA12)
⊙ 8	A1347EF	1	Fuse (see page 6-6)

#### Note:

\* 760503 - □ -D  
 † 760503 - □ -F  
 ‡ 760503 - □ -Q  
 § 760503 - □ -R

⊙ CMPL Parts

## 7.1 Disassembling the WT210

### WARNING

This service manual is to be used by properly trained personnel only. To avoid personal injury, do not perform any servicing unless you are qualified to do so. Refer to the safety precautions prior to performing any servicing. Even if servicing is carried out according to this service manual, Yokogawa shall not be responsible for any result occurring from that servicing.

### CAUTION

You must disconnect the power cable from the outlet before removing any assembly.

#### Removing the Cover Assembly

1. Remove the two screws attaching the Rear Bezel to the rear panel, and the one rear panel screw.

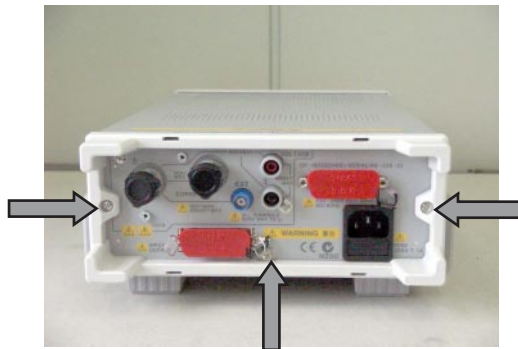

2. Hold the Cover Assembly steady while pushing the rear panel toward the front panel to slide the unit out from the cover.

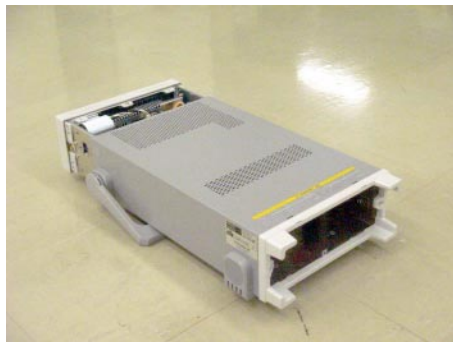

## 7.1 Disassembling the WT210

---

WT with the Cover Assembly removed



### Removing the Rear Bezel

1. Remove the two screws attaching the Rear Bezel to the rear panel of the WT.



2. The Rear Bezel is fastened to the Cover Assembly by tabs (two on the top and two on the bottom of the Cover Assembly). Use a tool such as a flathead screwdriver to push in the tabs, then remove the Rear Bezel.

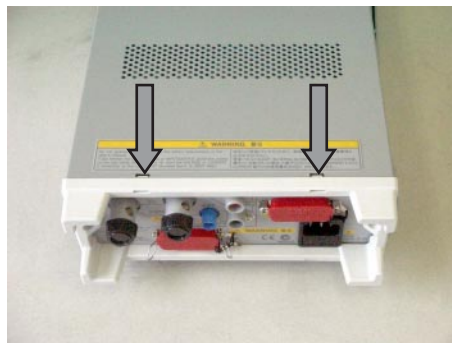

### Removing the Foot and Grip

3. Use a flat tool such as a razor blade to peel off the circle-shaped Sheets (2) from each side of the rear panel Foot.



4. Remove the screw from each side of the foot that was covered by the Sheets.



5. Remove the Foot.
6. Position the grip as shown in the figure below.

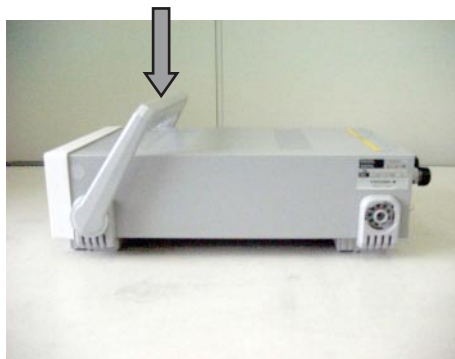

7. Pull out each side of the grip and make sure that the grip tabs align with the notches.
8. When the tabs are aligned, pull out the grip completely and remove it.



9. Remove the screw from each side of the foot that was covered by the grip.



10. Remove the Foot.

### Removing the Front Panel Assembly

1. Remove the Cover Assembly (see "Removing the Cover Assembly").
2. Remove one screw each from the left, right, and top sides of the Front Panel Assembly, and two screws from the bottom.

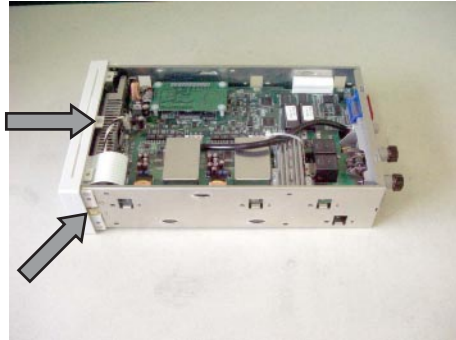

3. Push the metal tabs (to which the left and right screws in the previous step had been attached) toward the front of the unit and slide the Front Panel Assembly slightly outward and away from the rest of the unit.
4. Remove the cable connecting the Front Panel Assembly to the Main Board Assembly. Remove the Front Panel Assembly.

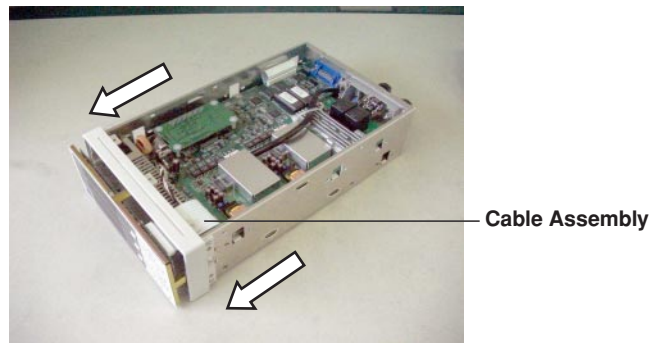

### Remove the Switching Power

1. Remove the Cover Assembly (see "Removing the Cover Assembly").
2. Remove the Front Panel Assembly (see "Removing the Front Panel Assembly").
3. Remove the cable connecting the Switching Power to the Main Board Assembly.
4. Remove the four screws holding the Switching Power in place.

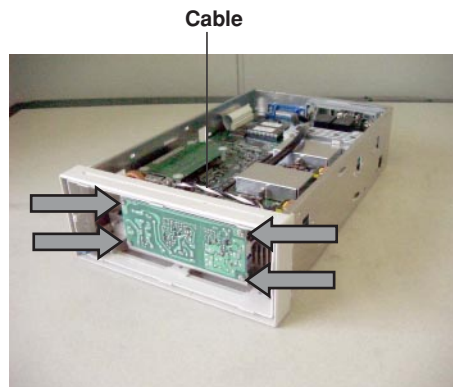

5. Disconnect the cable attached to the Power Switch Assembly. Remove the Power Switch Assembly.



Cable

### Removing the CMP Board Assembly and the DA4CH Board Assembly

1. Remove the Cover Assembly (see "Removing the Cover Assembly").
2. Disconnect the ribbon cable from the Main Board Assembly.

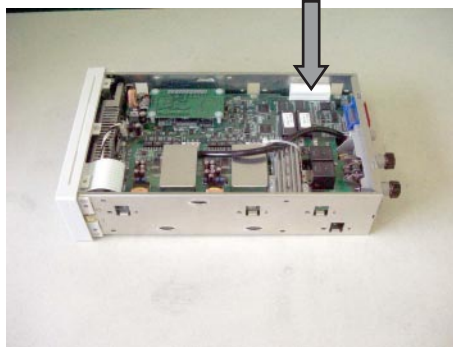

3. Turn the unit upside down.
4. Remove the two board screws and the two connector screws on the rear panel, then remove the board.

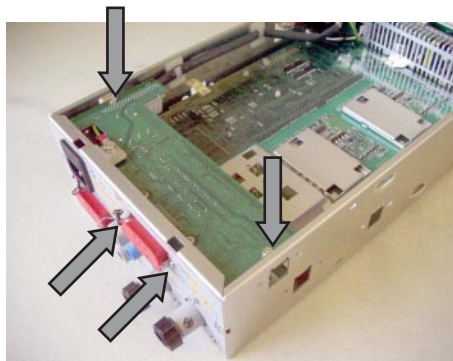

### Removing the Main Board Assembly

1. Remove the Cover Assembly (see “Removing the Cover Assembly”).
2. Remove the two rear panel screws and the two communications connector screws as shown.
3. Unscrew the input terminal Knob Assemblies to remove them.

**Note**

---

- The Knob Assembly will catch on its built-in stopper as you unscrew it. Continue turning through the stopper to remove it. The stoppers can fall out through the holes in the input terminals, so be careful not to lose them.

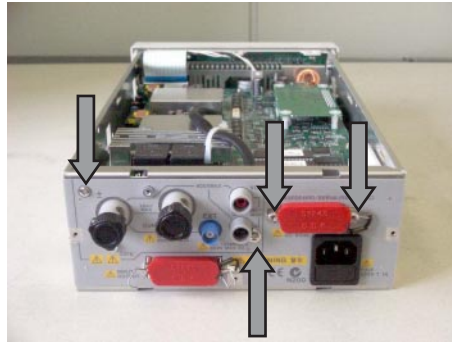

Knob Assembly and Stopper



- When attaching the Knob Assembly, use tweezers to place the stopper in the center hole of the input terminal ahead of time, then turn the Knob Assembly so that the stopper fits into the knob as it enters the terminal. Turn the knob until it is tight.

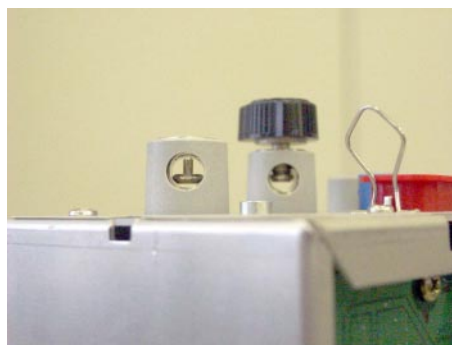

**WT with the Rear Panel screw and Knob Assembly removed**



4. Pull out the three Main board Assembly cables (if not already pulled out).
5. Remove the seven screws holding the Main Board Assembly in place.

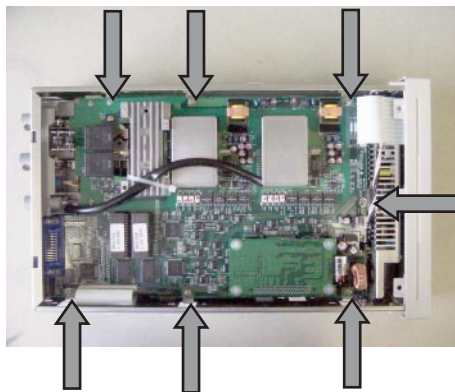

6. Pull up the Main Board Assembly from the front panel side to remove it from the rest of the unit.



---

## 7.2 Disassembling the WT230

---

### WARNING

This service manual is to be used by properly trained personnel only. To avoid personal injury, do not perform any servicing unless you are qualified to do so. Refer to the safety precautions prior to performing any servicing. Even if servicing is carried out according to this service manual, Yokogawa shall not be responsible for any result occurring from that servicing.

---

---

### CAUTION

You must disconnect the power cable from the outlet before removing any assembly.

---

---

#### Removing the Top Cover

1. Remove the screws from each upper left and right Foot, and the screw holding the Top Cover in place.

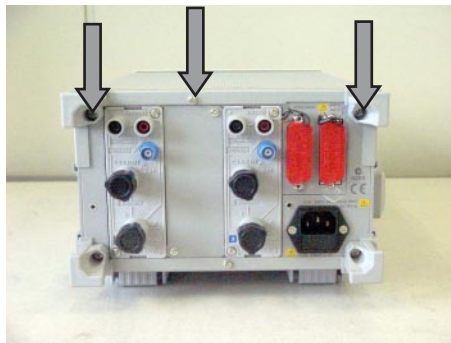

2. Remove the Top Cover by pulling it up and toward the rear of the instrument.

#### Removing the Bracket Assembly

1. Remove the Top Cover (see "Removing the Top Cover").
2. Remove the six screws attaching the Bracket Assembly, and the four screws attaching the Bracket.

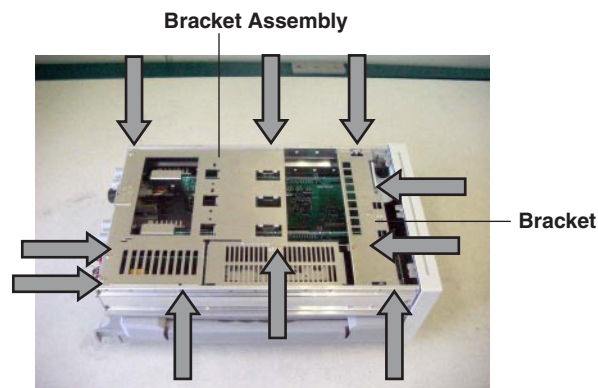

- Remove the three screws that attach the Input Assemblies at the top of the Rear Panel (for the 760502, this includes the Panel).

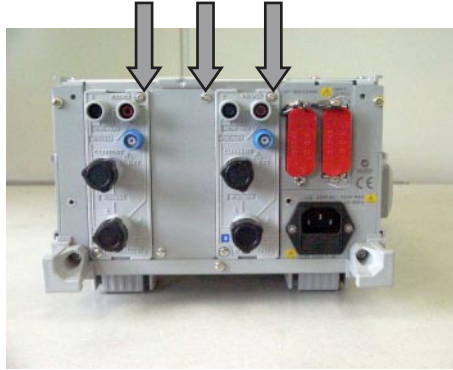

- Remove the Bracket Assembly and the Bracket.  
**Unit with the Bracket Assembly and Bracket removed**



### Removing the Input Assemblies

- Remove the Top Cover (see "Removing the Top Cover").
- Remove the screws on the lower part of each input Assembly.

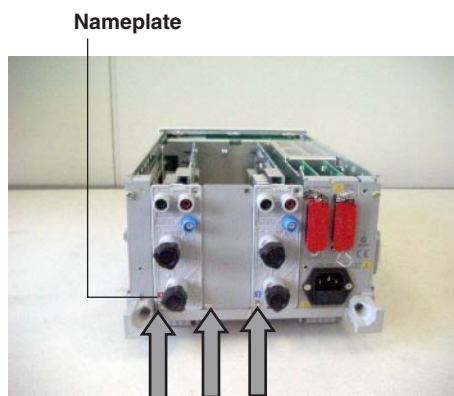

- Remove the Input Assemblies.

#### Note

When replacing an Input Assembly, attach the appropriate Nameplate to the Panel according to the chart below. The assemblies are inserted into the main unit from left to right starting with number 1.

Part No.	Nameplate Number
A9417ZJ	1
A9418ZJ	2
A9419ZJ	3

### Removing Communications and Option Boards

1. Remove the Top Cover (see "Removing the Top Cover").
2. Remove the Bracket Assembly (see "Removing the Assembly").
3. Remove the four screws from the connectors.

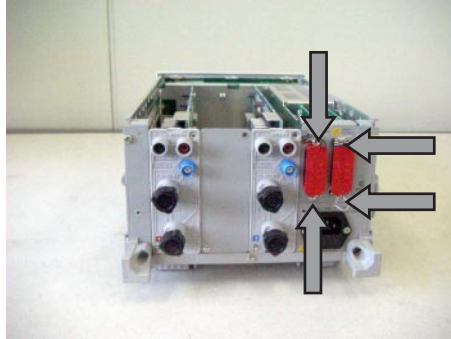

4. Remove the cover.
5. Pull out each board.

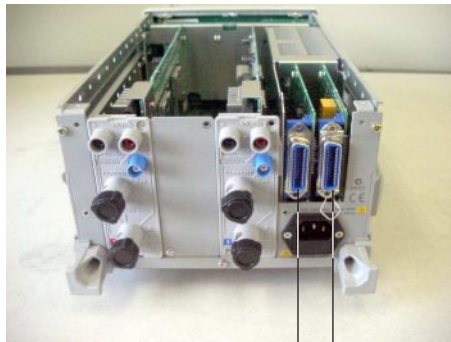

DA12CH /CMP Board  
GP-IB /RS-232-C Board

### Removing the Power Supply

1. Remove the Top Cover (see "Removing the Top Cover").
2. Remove the Bracket Assembly (see "Removing the Assembly").
3. Remove the Input Assembly (see "Removing the Input Assembly").
4. Remove the communications board and option board (see "Removing the Communications and Option Boards").
5. Remove the three screws from the Bracket.

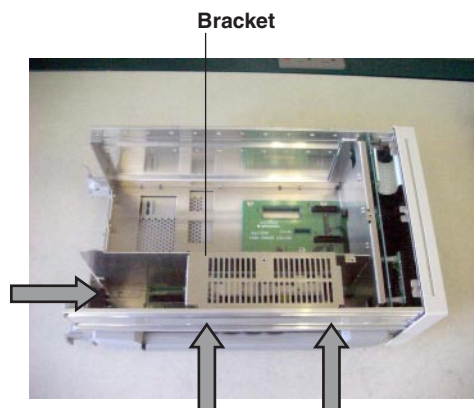

6. Slide the Bracket out, then tilt it so you can see the attached cables.

7. Locate the two cables connecting the Power Supply and Mother Board Assembly, then pull out the cables from the connectors.
8. Remove the ground wire screw. Remove the Power Supply.

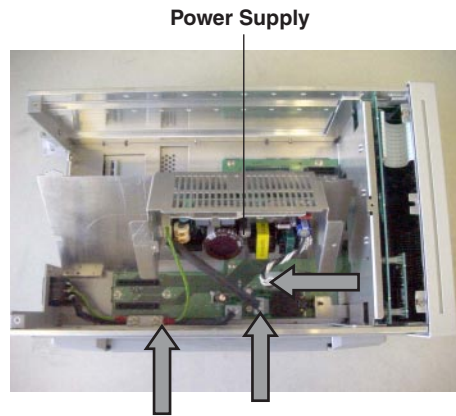

### Removing the CPU Board Assembly and the Harm Board Assembly

1. Remove the Top Cover (see "Removing the Top Cover").
2. Remove the Bracket Assembly (see "Removing the Assembly").
3. Disconnect the flat cable connecting the Display Board Assembly and the CPU Board Assembly.

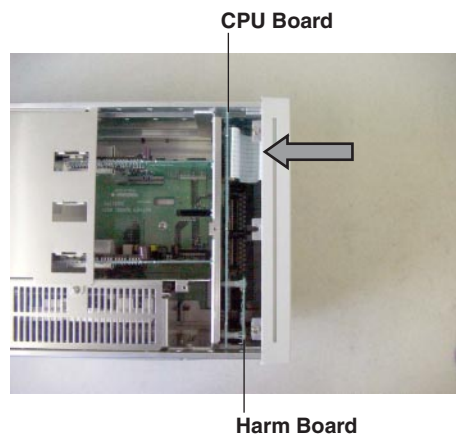

4. Pull the CPU Board Assembly and Harm Board Assembly up and outwards.

### Removing the Front Panel Assembly

1. Remove the Top Cover (see "Removing the Top Cover").
2. Remove the screw in each Foot on the bottom of the rear panel, and the center screw holding the Bottom Cover in place.

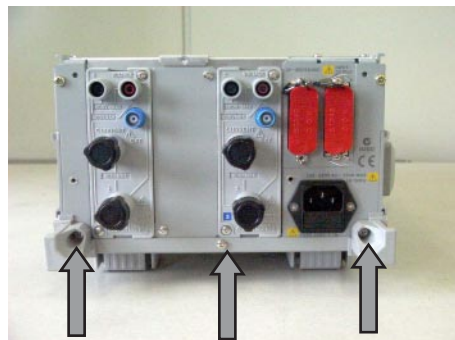

## 7.2 Disassembling the WT230

---

3. Slide the unit along the base toward the front, and remove the Bottom Cover.  
**Unit with the Top and Bottom Covers removed**



4. Remove the two screws from the upper part of the Front Panel Assembly.

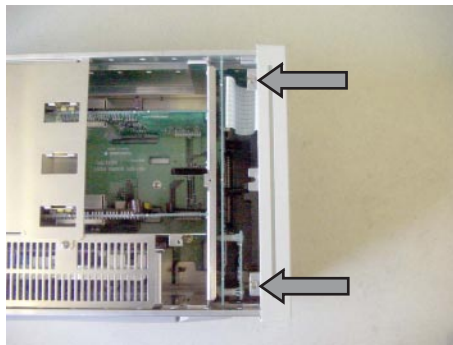

5. Remove the two screws from the lower part of the Front Panel Assembly.

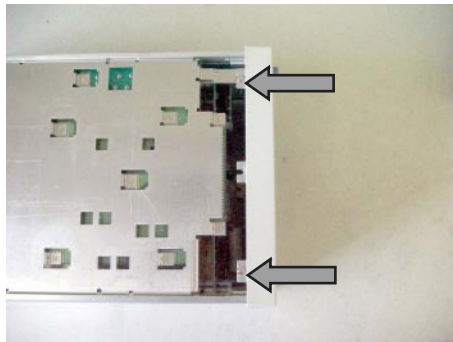

6. Pull the Front Panel Assembly toward you slightly, then disconnect the cable connecting the Front Panel Assembly to the CPU Board Assembly (if not already disconnected). Remove the Front Panel Assembly.

