

Service Guide

Agilent Technologies E4428C/38C ESG Signal Generators

This guide applies to the following signal generator models:

E4428C ESG Analog Signal Generator

E4438C ESG Vector Signal Generator

Due to our continuing efforts to improve our products through firmware and hardware revisions, signal generator design and operation may vary from descriptions in this guide. We recommend that you use the latest revision of this guide to ensure you have up-to-date product information. Compare the print date of this guide (see bottom of page) with the latest revision, which can be downloaded from the following website:

<http://www.agilent.com/find/esg>



Part Number: E4400-90511

Printed in USA

January 2011

© Copyright 2001-2011 Agilent Technologies, Inc.

Notice

The material contained in this document is provided “as is”, and is subject to being changed, without notice, in future editions.

Further, to the maximum extent permitted by applicable law, Agilent disclaims all warranties, either express or implied with regard to this manual and to any of the Agilent products to which it pertains, including but not limited to the implied warranties of merchantability and fitness for a particular purpose. Agilent shall not be liable for errors or for incidental or consequential damages in connection with the furnishing, use, or performance of this document or any of the Agilent products to which it pertains. Should Agilent have a written contract with the User and should any of the contract terms conflict with these terms, the contract terms shall control.

1. Troubleshooting

Before Troubleshooting	1-2
ESD Information	1-2
Getting Started with Troubleshooting	1-3
Troubleshooting Aids	1-3
ILT-1 Power Supply Failure and Self-Test	1-4
ILT-2 A12 CPU Power-On Test	1-4
ILT3 Front Panel Display Troubleshooting	1-8
Symptom: If the Display is Dark	1-8
Symptom: If the Display is Bright, but without Characters	1-11
Symptom: If Hardkeys or Softkeys are Not Functioning	1-13
Symptom: If the RPG Knob is Not Functioning	1-15
Symptom: If the Screen Saver is Not Functioning	1-16
Self-Test Failures and Related Troubleshooting	1-17
Overview	1-17
Running Self-Test	1-17
Troubleshooting Assembly Level Problems	1-21
Power Supplies	1-21
Self-Tests 1xx for the A10 I/Q Multiplexer (E4438C Only)	1-28
Self-Tests 2xx for the A15 Sampler	1-30
Self-Tests 4xx for the A13 Output	1-33
Self-Tests 5xx for the A17 Synthesizer	1-37
Self-Tests 6xx for the A21 YTO Driver	1-40
Self-Tests 7xx for the A16 Frac-N	1-43
Self-Tests 8xx for the A18 Reference	1-48
Self-Tests 11xx for the A12 CPU	1-50
Self-Tests 14xx for the A11 Internal Bit Error Rate Analyzer (E4438C Only)	1-52
Self-Tests 15xx for the A9 Digital Demodulator (E4438C Only)	1-54
Self-Tests 16xx for the A7 Baseband Generator (E4438C Only)	1-56
Self-Tests 20xx for the A14 Extended Frequency Output	1-59
Self-Tests 21xx for the A23 Motherboard	1-62
Self-Tests 23xx for the A13 Output	1-64
Troubleshooting Unlocks	1-68
514 Reference Oven Cold	1-68
515 10 MHz Signal Bad	1-68
512 Reference Unlocked	1-69
513 1 GHz Out of Lock	1-69

508 Frac-N Loop Unlock (Option 501, 502, 503, 504)	1-69
508 Frac-N Loop Unlock (Option UNJ and Option 506)	1-69
520 Sampler Unlocked (Option UNJ and Option 506)	1-69
521 YO Loop Unlocked (Option UNJ and Option 506)	1-71
516 Baseband Generator Unlock (E4438C Only)	1-71
623 Demod Unlock (E4438C Only)	1-72
Troubleshooting Unlevels and the RF Path	1-73
Troubleshooting a Leveling Problem	1-73
Troubleshooting the AT1 Electronic Attenuator	1-78
Troubleshooting the AT1 High-Power Mechanical Attenuator	1-81
Troubleshooting Adjustment Problems	1-84
Troubleshooting Analog Bus ADC Calibration Failures	1-87
Procedure for Signal Generators with Option 501, 502, 503, 504	1-87
Procedure for Signal Generators with Option UNJ	1-88
Procedure for Signal Generators with Option 506	1-89
Troubleshooting Performance Test Problems	1-90
Troubleshooting Harmonic Spurious	1-97
Troubleshooting Harmonic Spurious by Fundamental Frequency	1-97
To Verify Harmonic Performance at the RF Output	1-98
To Verify Harmonic Performance at the Coherent Carrier Output	1-98
Troubleshooting Non-Harmonic Spurious	1-100
Troubleshooting Phase Noise (Option UNJ and Option 506 Only)	1-102
Troubleshooting Pulse Modulation and LF Out	1-103
To Verify the Pulse Waveform at the A19 Daughterboard (All Options)	1-103
To Verify the Pulse Waveform at the A19 Daughterboard (Option 506 Only)	1-105
No Pulse Signal from LF Out	1-106
Troubleshooting I/Q Calibration (E4438C Only)	1-108
Pre-Troubleshooting Checklist	1-108
I/Q Calibration Troubleshooting	1-109
Contacting Agilent Technologies	1-113
Review the Warranty	1-113
Contacting Agilent Sales and Service Offices	1-113
Important Information Needed by an Agilent Service Representative	1-113
Returning a Signal Generator for Service	1-114
Block Descriptions	1-115
Overall Block Description for Option 501, 502, 503, 504	1-116

Overall Block Diagram for Option 501, 502, 503, 504	1-119
Frequency Synthesis Block Description for Option 501, 502, 503, 504	1-121
Frequency Synthesis Block Diagram for Option 501, 502, 503, 504	1-123
RF Path Block Description for Option 501, 502, 503, 504	1-125
RF Path Block Diagram for Option 501, 502, 503, 504	1-127
Overall Block Description for Option UNJ and Option 506	1-129
Overall Block Diagram for Option UNJ and Option 506	1-133
Frequency Synthesis Block Description for Option UNJ and Option 506	1-135
Frequency Synthesis Block Diagram for Option UNJ and Option 506 (Page 1 of 2)	1-137
Frequency Synthesis Block Diagram for Option UNJ and Option 506 (Page 2 of 2)	1-139
RF Path Block Description for Option UNJ or Option 506	1-141
RF Path Block Diagram for Option UNJ and Option 506 (Page 1 of 2)	1-145
RF Path Block Diagram for Option UNJ and Option 506 (Page 2 of 2)	1-147
Analog Modulation Block Description for All Options	1-149
Analog Modulation Block Diagram for All Options	1-151
Digital Modulation Block Description for All E4438C Options	1-153
Digital Modulation Block Diagram for All E4438C Options	1-155

2. Replaceable Parts

Ordering Information	2-2
Order Parts Fast	2-2
Save Money with Rebuilt-Exchange Assemblies	2-3
Shipping a Defective Assembly Back to Agilent Technologies	2-4
Frequency, Hardware, and Personality Options	2-5
Assemblies and Hardware Options	2-7
Assemblies from a Top View	2-10
Assemblies from a Right-Side View	2-17
Assemblies of the Front Panel	2-19
Assemblies of the Inside Rear Panel	2-21
A23BT1 Battery	2-23
Cables	2-24
Inside Front Panel and Fan Cables	2-24
Option 501, 502, 503, 504 Cables	2-24
Option UNJ Cables	2-24
Option 506 Cables	2-25
Cables for the Inside Front Panel and Fans	2-26

Contents

Cables for Option 501, 502, 503, 504 Signal Generators	2-28
Overall Cables - Includes Cables for Option UN7, 300, 005, and 001/601 or 002/602)	2-28
Front Panel Cables	2-31
Standard Cables - Does Not Include Cables for the Front Panel, Option UN7, 300, or 005	2-32
Only Option UN7, 300, 005, and 001/601 or 002/602 Cables	2-33
Semi-Rigid Cables - Includes the AT1 Electronic Attenuator or the AT1 High-Power Mechanical Attenuator (Option UNB) with the A28 Reverse Power Protection	2-34
Option 1EM Overall Cables - Includes Cables for Option UN7, 300, 005, and 001/601 or 002/602)	2-35
Option 1EM Semi-Rigid Cables - Includes the AT1 Electronic Attenuator or the AT1 High-Power Mechanical Attenuator (Option UNB) with the A28 Reverse Power Protection	2-38
Cables for Option UNJ Signal Generators	2-39
Overall Cables - Includes Cables for Option UN7, 005, and 001/601 or 002/602	2-39
Front Panel Cables	2-42
Standard Cables - Does Not Include Cables for the Front Panel, Option UN7, 300, or 005	2-43
Only Option UN7, 300, 005, and 001/601 or 002/602 Cables	2-44
Semi-Rigid Cables - Includes the A21 YTO Driver and the AT1 Electronic Attenuator or the AT1 High-Power Mechanical Attenuator (Option UNB) with A28 Reverse Power Protection	2-45
Option 1EM Overall Cables - Includes Cables for Option UN7, 005, and 001/601 or 002/602)	2-47
Option 1EM Semi-Rigid Cables - Includes the A21 YTO Driver and the AT1 Electronic Attenuator or the AT1 High-Power Mechanical Attenuator (Option UNB) with A28 Reverse Power Protection	2-50
Cables for Option 506 Signal Generators	2-52
Overall Cables - Includes Cables for Option UN7, 005, and 001/601 or 002/602	2-52
Front Panel Cables	2-55
Standard Cables - Does Not Include Cables for the Front Panel, Option UN7, or Option 005	2-56
Only Option UN7, 005, and 001/601 or 002/602 Cables	2-58
Semi-Rigid Cables - Includes the A21 YTO Driver and the AT1 High-Power Mechanical Attenuator (Option UNB) with an A29 DC Blocking Capacitor	2-59
Option 1EM Overall Cables - Includes Cables for Option UN7, 005, and 001/601 or 002/602)	2-61
Option 1EM Semi-Rigid Cables - Includes the A21 YTO Driver and the AT1 High-Power Mechanical Attenuator (Option UNB) with an A29 DC Blocking Capacitor	2-64
Hardware and Other Instrument Parts	2-66
Front Panel	2-67
Disassembled Front Panel	2-69
Rear-Panel Hardware	2-72
Rear-Panel (Option 1EM)	2-75
Disassembled AT1 Electronic Attenuator	2-78

Disassembled AT1 High-Power Mechanical Attenuator (Option UNB) and A28 Reverse Power Protection (Option 501, 502, 503, 504 or Option UNJ)	2-79
Disassembled AT1 High-Power Mechanical Attenuator (Option 506 Only)	2-81
Disassembled A6 Power Supply Shield and Left-Side	2-82
Disassembled A23 Motherboard and Bottom-Side	2-83
Outside Instrument Covers and Associated Parts	2-84
Inside Instrument Covers and Associated Parts	2-86
Miscellaneous	2-87
Accessories	2-87
Documentation	2-87
Abbreviations Used in Part Descriptions	2-88

3. Assembly Replacement

Before You Replace an Assembly	3-2
After Replacing or Repairing an Assembly	3-2
Assemblies That You Can Replace	3-3
Outer and Inner Instrument Covers	3-4
Tools Required	3-4
Removal Procedures	3-4
Replacement Procedure	3-4
Front Panel	3-6
Tools Required	3-6
Removal Procedure	3-6
A1 Keyboard	3-8
Tools Required	3-8
Removal Procedure	3-8
Replacement Procedure	3-8
A2 Display	3-11
Tools Required	3-11
Removal Procedure	3-11
Replacement Procedure	3-11
A2DS1 Display Backlight	3-14
Tools Required	3-14
Removal Procedure	3-14
Replacement Procedure	3-14
A3 Front Panel Auxiliary Board	3-17
Tools Required	3-17

Contents

Removal Procedure	3-17
Replacement Procedure	3-17
A4 Inverter	3-19
Tools Required	3-19
Removal Procedure	3-19
Replacement Procedure	3-19
A5 Hard Drive (E4438C Only)	3-21
Tools Required	3-21
Removal Procedure	3-21
Replacement Procedure	3-21
A6 Power Supply	3-24
Tools Required	3-24
Removal Procedure	3-24
Replacement Procedure	3-24
A7 Baseband Generator (E4438C Only)	3-26
Tools Required	3-26
Removal Procedure	3-26
Replacement Procedure	3-26
A9 Digital Demodulator (E4438C Only)	3-28
Tools Required	3-28
Removal Procedure	3-28
Replacement Procedure	3-28
A10 I/Q Multiplexer (E4438C Only)	3-30
Tools Required	3-30
Removal Procedure	3-30
Replacement Procedure	3-30
A11 Internal Bit Error Rate Analyzer (E4438C Only)	3-32
Tools Required	3-32
Removal Procedure	3-32
Replacement Procedure	3-32
A12 CPU	3-34
Tools Required	3-34
Removal Procedure	3-34
Replacement Procedure	3-35
A13 Output	3-36
Tools Required	3-36
Removal Procedure	3-36

Replacement Procedure	3-36
A14 Extended Frequency Output	3-38
Tools Required	3-38
Removal Procedure	3-38
Replacement Procedure	3-38
A15 Sampler	3-40
Tools Required	3-40
Removal Procedure	3-40
Replacement Procedure	3-40
A16 Frac-N	3-42
Tools Required	3-42
Removal Procedure	3-42
Replacement Procedure	3-42
A17 Synthesizer	3-44
Tools Required	3-44
Removal Procedure	3-44
Replacement Procedure	3-44
A18 Reference	3-46
Tools Required	3-46
Removal Procedure	3-46
Replacement Procedure	3-46
A19 Daughterboard	3-48
Tools Required	3-48
Removal Procedure	3-48
Replacement Procedure	3-48
A19 Daughterboard Cable Removal	3-50
Tools Required	3-50
Removal Procedure	3-50
Replacement Procedure	3-50
A20 Downconverter (E4438C Only)	3-52
Tools Required	3-52
Removal Procedure	3-52
Replacement Procedure	3-52
A21 YTO Driver and A22 Coupler	3-54
Tools Required	3-54
Removal Procedure	3-54
Replacement Procedure	3-55

Contents

A23 Motherboard	3-56
Tools Required	3-56
Removal Procedure	3-56
Replacement Procedure	3-57
A23BT1 Battery	3-59
Tools Required	3-59
Removal Procedure	3-59
Replacement Procedure	3-59
A24 Line Module	3-60
Tools Required	3-60
Removal Procedure	3-60
Replacement Procedure	3-60
Rear Panel	3-62
Tools Required	3-62
Removal Procedure	3-62
Replacement Procedure	3-62
A25 Rear Panel Board (E4438C Only)	3-64
Tools Required	3-64
Removal Procedure	3-64
Replacement Procedure	3-64
A26 Rear Panel LVDS Board (Option 1EM — E4438C Only) and A27 Rear Panel SMB Board (Option 1EM — E4438C Only)	3-66
Tools Required	3-66
Removal Procedure	3-66
Replacement Procedure	3-66
AT1 High-Power Mechanical Attenuator with A28 Reverse Power Protection	3-68
Tools Required	3-68
Removal Procedure	3-68
Replacement Procedure	3-68
AT1 High-Power Mechanical Attenuator	3-70
Tools Required	3-70
Removal Procedure	3-70
Replacement Procedure	3-70
AT1 Electronic Attenuator	3-72
Tools Required	3-72
Removal Procedure	3-72
Replacement Procedure	3-72

A29 DC Blocking Capacitor	3-74
Tools Required	3-74
Removal Procedure	3-74
Removal Procedure for Option 1EM	3-74
Replacement Procedure	3-74
B1 Power Supply Fan	3-76
Tools Required	3-76
Removal Procedure	3-76
Replacement Procedure	3-76
B2 Small Fan	3-78
Tools Required	3-78
Removal Procedure	3-78
Replacement Procedure	3-78
B3 Daughterboard/Card Cage Fan	3-80
Tools Required	3-80
Removal Procedure	3-80
Replacement Procedure	3-80
RF Output Connector	3-82
Tools Required	3-82
Removal Procedure	3-82
Removal Procedure for Option 1EM	3-82
Replacement Procedure	3-83
4. Post-Repair Procedures	
Performance Tests	4-2
Adjustment Tests	4-8
5. Safety and Regulatory	
Safety Notes	5-2
General Safety Considerations	5-3
Lithium Battery Disposal	5-4
Assistance	5-5
Notice	5-6
Certification	5-7

Documentation Overview

Installation Guide

- Safety Information
- Getting Started
- Operation Verification
- Regulatory Information

User's Guide

- E4428C Analog Signal Generator Overview
- E4423C Analog Signal Generator Overview
- Basic Operation
- Basic Digital Operation
- AWGN Waveform Generator
- Analog Modulation
- Digital Signal Interface Module
- Bluetooth Signals
- BERT
- CDMA Digital Modulation
- GPS Modulation
- Multitone Waveform Generator
- Custom Digital Modulation
- Real Time TDMA Formats
- W-CDMA Digital Modulation for Component Test
- W-CDMA Uplink Digital Modulation for Receiver Test
- W-CDMA Downlink Digital Modulation for Receiver Test
- Troubleshooting

Programming Guide

- Getting Started with Remote Operation
- Using IO Interfaces
- Programming Examples
- Programming the Status Register System
- Creating and Downloading Waveform Files
- Creating and Downloading User-Data Files

SCPI Reference

Volume 1:

- SCPI Basics
- Basic Function Commands
- System Commands
- Analog Commands
- Component Test Digital Commands

Volume 2:

- Digital Signal Interface Module Commands
- Bit Error Rate Test (BERT) Commands
- Receiver Test Digital Commands

Volume 3:

- Receiver Test Digital Commands (continued)

Compatibility with E44xxB SCPI Commands

- Overview
- E4428C/38C SCPI Commands
- ESG E44xxB Commands
- 8648A/B/C/D Commands
- 8658B, 8657A/B/D/J Programming Codes

Service Guide

- Troubleshooting
- Replaceable Parts
- Assembly Replacement
- Post-Repair Procedures
- Safety and Regulatory

Key and Data Field Reference

Volume 1:

- Symbols, Numerics, A-H

Volume 2:

- Volume 2: I-Z

1 Troubleshooting

Before Troubleshooting

WARNING These troubleshooting instructions are for use by qualified personal only. To avoid electrical shock, do not perform any troubleshooting unless qualified.

WARNING The opening of covers or removal of parts is likely to expose dangerous voltages. Disconnect the signal generator from all voltage sources before it is opened.

WARNING The following techniques related to ESD and static-safe workstations should not be used when working on circuitry with a voltage potential greater than 500 volts.

ESD Information

Protection from Electrostatic Discharge

Electrostatic discharge (ESD) can damage or destroy electronic components. All work on electronic assemblies should be performed at a static-safe workstation using two types of static-safe workstation protection:

- conductive table-mat and wrist-strap combination
- conductive floor-mat and heel-strap combination

Both types, when used together, provide a significant level of ESD protection. Of the two, only the table-mat and wrist-strap combination provides adequate ESD protection when used alone. To ensure user safety, the static-safe accessories must provide at least 1 meg ohm of isolation from ground.

Handling of Electronic Components and ESD

CAUTION Many of the assemblies in this signal generator are very susceptible to damage from electrostatic discharge (ESD). Perform troubleshooting procedures only at a static-safe workstation and wear a grounding strap.

CAUTION Always handle printed circuit board assemblies by the edges. This will reduce the possibility of ESD damage to components and prevent contamination of exposed plating.

The possibility of unseen damage caused by ESD is present whenever components are transported, stored, or used. The risk of ESD damage can be greatly reduced by close attention to how all components are handled.

- Perform work on all components at a static-safe workstation.
- Keep static-generating materials at least one meter away from all components.
- Store or transport components in static-shielding containers.

Getting Started with Troubleshooting

Determine the starting point in [Table 1-1](#) to begin troubleshooting.

- Problems should be worked on in the order they are presented in this table.
- Overviews of Self-Test, Frequency Synthesis, RF Path, Analog Modulation, and Digital Modulation are found in this chapter. The information in these overviews may help the reader better understand how the signal generator operates and the function of each assembly. Each overview is also intended to be used to troubleshoot the signal generator.

Table 1-1

If able to run self-test...	Go to this section...
Run Self-Test	“ Self-Test Failures and Related Troubleshooting ” on page 1-17 and refer to the procedure “ Running Self-Test ” on page 1-17.
If unable to run self-test, check...	Go to this section...
Power Supply Failures A12 CPU Power-on Failures Front Panel Display or Keyboard Operations	“ ILT-1 Power Supply Failure and Self-Test ” on page 1-4 “ ILT-2 A12 CPU Power-On Test ” on page 1-4 “ ILT3 Front Panel Display Troubleshooting ” on page 1-8
If other conditions occur...	Go to this section...
Unlocked Conditions Unleveled Conditions Adjustment Problems Performance Test Problems I/Q Calibration Failure	“ Troubleshooting Unlocks ” on page 1-68 “ Troubleshooting Unlevels and the RF Path ” on page 1-73 “ Troubleshooting Adjustment Problems ” on page 1-84 “ Troubleshooting Performance Test Problems ” on page 1-90 “ Troubleshooting I/Q Calibration (E4438C Only) ” on page 1-108

Troubleshooting Aids

- semi-rigid cable-extender probe

The Agilent E8251-20088 semi-rigid cable-extender probe is used for measuring signals from connectors that are located inside the A19 Daughterboard card-cage.

- ribbon cable extender

The ribbon cable extender needs to be assembled by the user. It consists of two connector plugs (part number 1252-1010) and approximately eight inches of ribbon cable (part number 8120-2226). The ribbon cable contains 26 wires; six of these wires, on either the right or the left side, need to be stripped off before being connected to the plugs.

ILT-1 Power Supply Failure and Self-Test

When the signal generator appears to be dead (no display or fan) there is often little evidence that points directly to the cause. This section provides steps and solutions to typical failure modes.

CAUTION Immediately unplug the signal generator from the ac power line if the unit shows any of the following symptoms:

- Smoke, arcing, or unusual noise from inside the signal generator.
- A circuit breaker or fuse on the main ac power line opens.

These potentially serious faults must be corrected before proceeding.

Power Supply LED Checks

- o Check the front panel LEDs (located next to the LINE switch) for normal operation in both standby and power-on conditions. Normal operation is indicated as follows:

Table 1-2

Power Switch	Yellow LED	Green LED
Standby	On	Off
Power-On	Off	On

- If normal operation is not observed, refer to [“Power Supplies” on page 1-21](#).
- If the fan does not operate when the signal generator is powered on, refer to the assembly level troubleshooting section and verify the fan voltage.
- If the fan operates when the signal generator is powered on, refer to [“ILT-2 A12 CPU Power-On Test” on page 1-4](#).

ILT-2 A12 CPU Power-On Test

A12 CPU Power-On Test

At power-on, the A12 CPU is designed to complete a series of operational checks. If all power supply voltages are present and the A12 CPU is working correctly, the operational checks are completed. Errors are reported if the A12 CPU has problems identifying other assemblies.

Failure Symptoms

- A2 Display is not functioning
- A12 CPU fails to complete the power-on check
- no LAN activity
- no signal generator control from the front panel
- error message is displayed after power-on

A2 Display is Not Functioning

Refer to [ILT3 Front Panel Display Troubleshooting on page 1-8](#).

A12 CPU Fails to Complete the Power-On Check

1. Turn the power off and remove outer and inner covers.
2. Turn the power on and verify that LEDs DS18 through DS25 of the A12 CPU are on. (Refer to [Figure 1-1](#) for the location of LEDs DS18 through DS25 of the A12 CPU.)
 - If any of the LEDs are off, turn the signal generator on its side and check the voltages in [Table 1-3](#) at the A23 Motherboard.
 - If the voltages are not present on connector J15 and J5 of the A23 Motherboard, refer to [“Power Supplies” on page 1-21](#).
 - If the voltages are present on connector J15 and J5 of the A23 Motherboard, turn the power off and remove the A12 CPU.
3. Use a DVM and measure the resistance from J15 to J8 and J5 to J7.
 - If the connector is open, change the A23 Motherboard.
 - If the connector measures good, change the A12 CPU.

Figure 1-1 LEDs DS18 through DS25 of the A12 CPU

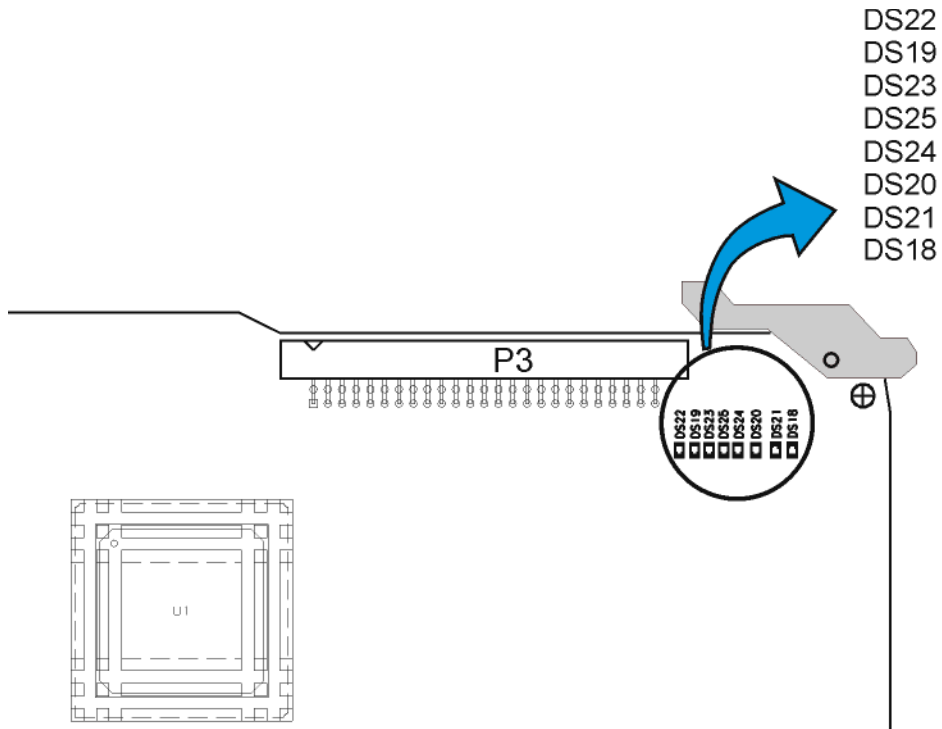

a12-cpu_ds18-25

Table 1-3

Power Supply Voltage (Vdc)	Connector Pins on the		Minimum Value (Vdc)	Maximum Value (Vdc)	LED on top-right corner of A12 CPU
	A12 CPU	A23 Motherboard			
+15	J8-103	J15-103	+14.1	+15.9	DS22
-15	J8-43	J15-43	-15.9	-14.1	DS19
+32	J8-44	J15-44	+31.04	+32.96	DS23
+5.2	J7-59, 60, 119, 120	J5-59, 60, 119, 120	+4.68	+5.72	DS25
+3.4	J7-55, 56, 57, 58, 115, 116, 117, 118	J5-55, 56, 57, 58, 115, 116, 117, 118	+3.298	+3.502	DS24
+9	J8-58	J15-58	+8.73	+9.27	DS20
-6	J8-57	J15-57	-6.36	-5.64	DS21
-5.2	J8-101	J15-101	-5.356	-5.044	DS18

Verifying the A12 CPU Power-On Sequence

1. Before verifying the power-on sequence, ensure that all eight DIP switches of S1 are in the CLOSED (up) position. (Refer to [Figure 1-2](#) and locate S1 in the upper left-hand corner of the A12 CPU.)
2. Verify the A12 CPU power-on sequence by observing DS1 through DS8.

When the power-on sequence is complete, DS1 through DS7 should be on and DS8 should be off.

- If the lights fail to step through the sequence, replace A12 CPU.
(Refer to “A12 CPU” on page 3-34.)

Figure 1-2 S1 and LEDs DS1 through DS8 and DS11 through DS17 of the A12 CPU

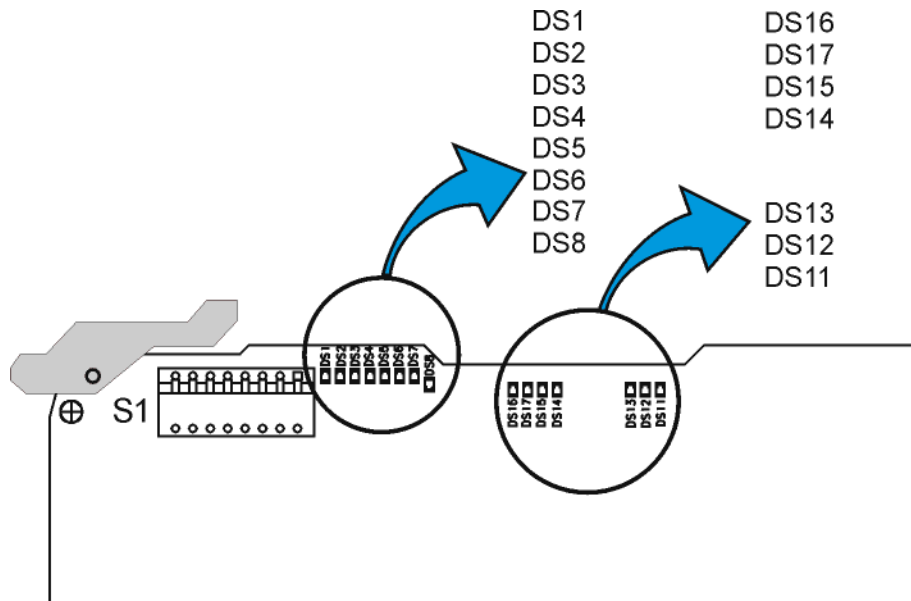

a12-cpu_ds1-17

Verifying the A5 10 GB Hard Drive

At power on, the hard drive’s file structure is verified.

- If the hard drive is not formatted, the A12 CPU formats it.
- If the file structure is corrupted, the A12 CPU recreates the structure; this may take up to 30 seconds during the power-on sequence.
- If the power-on sequence does not complete, perform the following:
 - a. Turn power off to the signal generator.
 - b. Disconnect the hard drive’s W26 ribbon cable from P3 of the A12 CPU.
 - c. Turn power on to the signal generator.
 - If the power-on sequence does not complete, refer to [A12 CPU Fails to Complete the Power-On Check<\\$elemparamonly\[Chapter\]>-5](#).
 - If the power-on sequence does complete, either the A5 10 GB Hard Drive or the A12 CPU hard drive interface is bad; these can be isolated by substitution.

No LAN Activity

The signal generator supports 10-Base T-LAN. When the instrument is connected to an active LAN, a green LED (DS16) should blink on the A12 CPU; the blinking LED represents data communication over the LAN. (Refer to [Figure 1-2](#) and locate DS16 in the upper middle of the A12 CPU.)

No Instrument Control From the Front Panel

Refer to [ILT3 Front Panel Display Troubleshooting](#)<\$elemparamonly[Chapter]>-8.

Error Messages Displayed After Power-On

If error messages are reported after the power-on check is completed, refer to the Error Messages manual for details.

ILT3 Front Panel Display Troubleshooting

The Front Panel Display consists of the following four assemblies:

- A1 Keyboard
- A2 Display (640 x 320 pixel liquid crystal display)
- A3 Front Panel Auxiliary Board
- A4 Inverter

The A1 Keyboard contains the front panel hardkeys and softkeys, the power on/off switch along with the standby LED, and the power-on LED. The eight LCD data lines for the A2 Display are routed through the A3 Front Panel Auxiliary Board; the A12 CPU controls these eight LCD data lines.

The A4 Inverter turns the A2 Display on and off using control lines routed through the A3 Front Panel Auxiliary Board, which originate on the A12 CPU. The A4 Inverter is used to convert a +5.2 Vdc signal into a 40 kHz 290 Vac signal (approximately); this ac signal is then used to drive the A2 Display.

A2 Display Contrast and Brightness Controls

There are two contrast hardkeys below the A2 Display. The left up-arrow key increases the contrast while the right down-arrow key decreases the contrast.

The A2 Display brightness can be adjusted from 50 (high brightness) to 1 (low brightness) using the RPG, arrow keys, or the numeric keypad.

Softkey Location: **Utility > Display > Brightness**

A2 Display Tests

There are two screen tests for the A2 Display: the Black Pixel Screen Test and the White Pixel Screen Test. The Black Pixel Screen Test turns the display dark and the White Pixel Screen Test turns the display bright. To exit either test, press any front panel key.

Softkey Location: **Utility > Display > More (1 or 2)**

Symptom: If the Display is Dark

The control lines for the A4 Inverter are routed from the A12 CPU through the A23 Motherboard and the A3 Front Panel Auxiliary Board to the A4 CN1 connector. The +5.2 Vdc is routed from the A6 Power Supply through the A23 Motherboard and the A3 Front Panel Auxiliary Board to the CN1 connector of the A4 Inverter.

Figure 1-3 A4 Inverter Connections

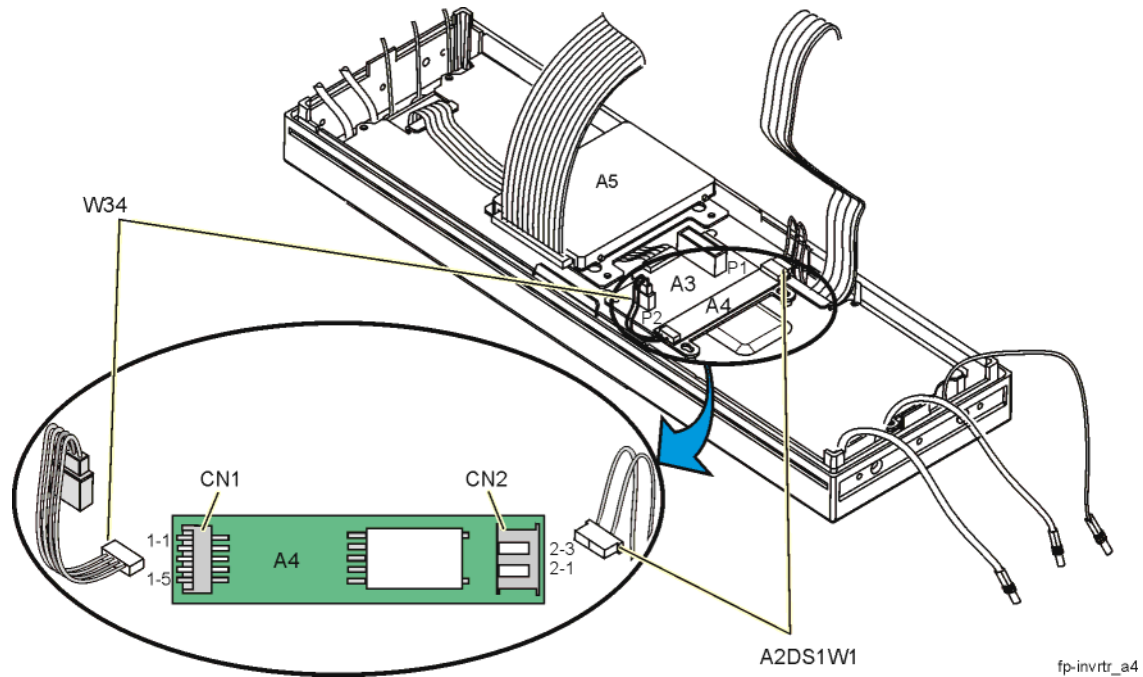

- o Check that the screen saver is not on.
 - Press any front panel key to disable the screen saver.
- o Check that the signal generator is powered-on and the front-panel green LED is lit.
 - If the green LED is not lit, refer to [Troubleshooting Assembly Level Problems on page 1-21](#).

WARNING High voltage is present at the A4 Inverter output (CN2-1). Also, while measuring CN2, be careful of the fan blades on B1, B2, and B3. Keep hands and fingers away from the fan blades to avoid injury!

- o Check the voltage, using a DVM, at the A4 Inverter output (CN2-1).
 - To access this connector and measure the voltage:
 1. Disconnect the front panel assembly from the chassis frame.
 2. Slide the front panel display away from the chassis while ensuring that the ribbon cables to the A23 Motherboard stay connected.

Getting Started with Troubleshooting

- o Check that there is approximately 290 Vac, 40 kHz signal at CN2-1. (This check should be made with the A4 Inverter connected to the A2 Display.)
 - If the signal is present at the A4 Inverter output, replace the A2 Display. (Refer to “A2 Display” on page 3-11.)
 - If the signal is not present at CN2, use a DVM to measure the signals shown in Table 1-4 at CN1 on the A4 Inverter. Probe CN1 from the top of the connector while it is still connected to the A3 Front Panel Auxiliary Board.

Table 1-4

Signal	State
CN1-1	5.2 Vdc
CN1-3 LIGHT_EN	>3 Vdc
CN1-4 VDISP	Brightness = 50, VDSP < 50 mVdc Brightness = 1, VDSP = 3 Vdc

- If the signals in Table 1-4 are correct, replace the A4 Inverter. (Refer to “A4 Inverter” on page 3-19.)
- If any of the signals are incorrect:
 - a. Using a DVM, measure the signals shown in Table 1-5 at J30 of the A23 Motherboard.
 - If the signals in Table 1-5 are correct, replace the A3 Front Panel Auxiliary Board. (Refer to “A3 Front Panel Auxiliary Board” on page 3-17.)
 - If the 5.2 VD_LCD line is incorrect, refer to the “ILT-1 Power Supply Failure and Self-Test” on page 1-4.
 - If either the LIGHT_EN or VDISP are incorrect:
 - a. Using a DVM, measure the signals at J15-37 (LIGHT_EN) or J15-97 (VDISP) of the A23 Motherboard.
 - If either signal is incorrect, replace the A12 CPU. (Refer to “A12 CPU” on page 3-34.)

Table 1-5

Signal	State
J30-32 5.2 VD_LCD	5.2 Vdc
J30-20 LIGHT_EN	>3 Vdc
J30-30 VDISP	Brightness = 50, VDSP < 50 mVdc Brightness = 1, VDSP = 3 Vdc

Symptom: If the Display is Bright, but without Characters

- o Check that the signal generator is powered-on and the front panel green LED is lit. If the green LED is not lit, refer to the Power Supply Troubleshooting section in this manual. Press any front panel key to disable the screen saver.
 - If the green LED is lit and the display is too bright, try adjusting the contrast controls on the front panel. Refer to “Symptom: If the Display is Dark” on page 1-8.
 - If adjusting the contrast controls has no effect, use an oscilloscope to check the signals in Table 1-6. The pulse-state signals listed are control, clock, and data lines for the A2 Display. Probe the signals on the back of the ribbon cable on P1 of the A3 Front Panel Auxiliary Board.

Table 1-6

Signal	State
J1-7 VLCD	approximately 21 Vdc
J1-4 LCD_EN_L	>3 Vdc
J1-5	5.2 Vdc
J1-8 to 15	Refer to Figure 1-4.

- If the signals in Table 1-6 are correct, replace the A2 Display. (Refer to “A2 Display” on page 3-11.)
- If the signals are incorrect, use an oscilloscope to check J30 on the A23 Motherboard for signals shown in Table 1-7.

Table 1-7

Signal	State
J30-3 VLCD	approximately 21 Vdc
J30-5 LCD_EN_L	>3 Vdc
Pulsing Activity LCD_DATA J1-8 to 15; J30-13, 14, 17, 18, 23, 24, 27, 28; J15-24, 25, 28, 29, 32, 33, 86, 90	Refer to Figure 1-4.
Pulsing Activity LCD_CLK J1-3; J30-4; J15-94	Refer to Figure 1-5.
Pulsing Activity LCD_LOAD J1-2; J30-8; J15-36	Refer to Figure 1-6.
Pulsing Activity LCD_FRAME J1-1; J30-7; J15-93	Refer to Figure 1-7.

**Figure 1-4 Pulsing Activity LCD_DATA
J1-8 to 15; J30-13, 14, 17, 18, 23, 24, 27, 28; J15-24, 25, 28, 29, 32, 33, 86, 90**

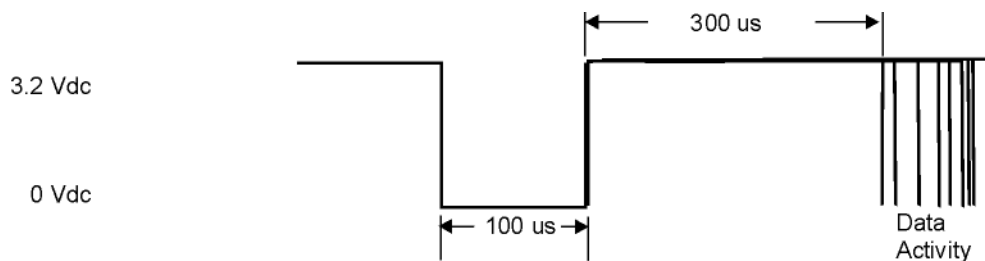

**Figure 1-5 Pulsing Activity LCD_CLK
J1-3, J30-4, J15-94**

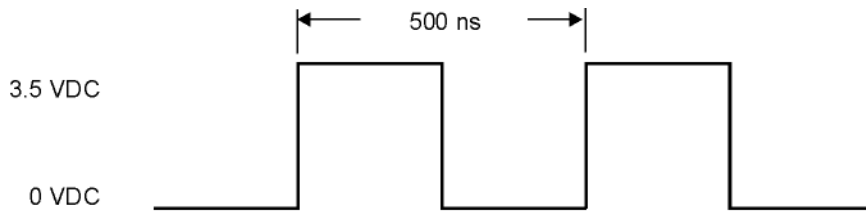

**Figure 1-6 Pulsing Activity
J1-2, J30-8, J15-36**

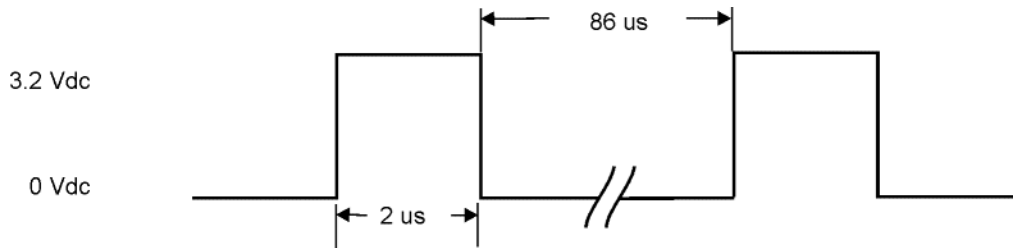

**Figure 1-7 Pulsing Activity
J1-1, J30-7, J15-93**

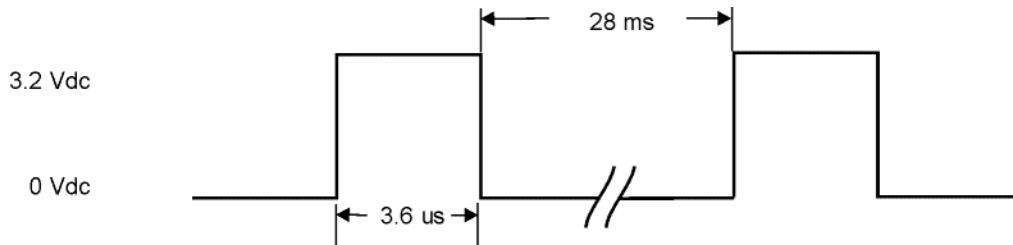

- If the signals in [Table 1-7](#) are correct, replace the A3 Front Panel Auxiliary Board. (Refer to [“A3 Front Panel Auxiliary Board”](#) on page 3-17.)
- If any of the signals are incorrect, use an oscilloscope to check J15 on the A23 Motherboard for signals shown in [Table 1-8](#).

Table 1-8

Signal	State
J15-35 VLCD	approximately 21 Vdc
J15-95 LCD_EN_L	>3 Vdc
J15-24, 25, 28, 29, 32, 33, 36, 86, 90, 93, 94	Refer to Figure 1-4 .

- If the signals in [Table 1-8](#) are incorrect, replace the A12 CPU (Refer to [“A12 CPU”](#) on page 3-34).

Symptom: If Hardkeys or Softkeys are Not Functioning

The A1 Keyboard contains the switches for the hardkeys and softkeys. These hardkeys and softkeys are arranged in a matrix, as shown in [Table 1-9](#), with the control lines KEYCOLx and KEYROWy on the x and y-axis. When a hardkey or softkey is pressed, one cell of the matrix is activated. The normally TTL low KEYROWy, of the active cell, will pulse high and the normally TTL high KEYCOLx, of the active cell, will pulse low. These TTL signals may be measured with an oscilloscope at J32 on the A23 Motherboard. Use [Table 1-9](#) for hardkey and softkey matrix locations.

Figure 1-8

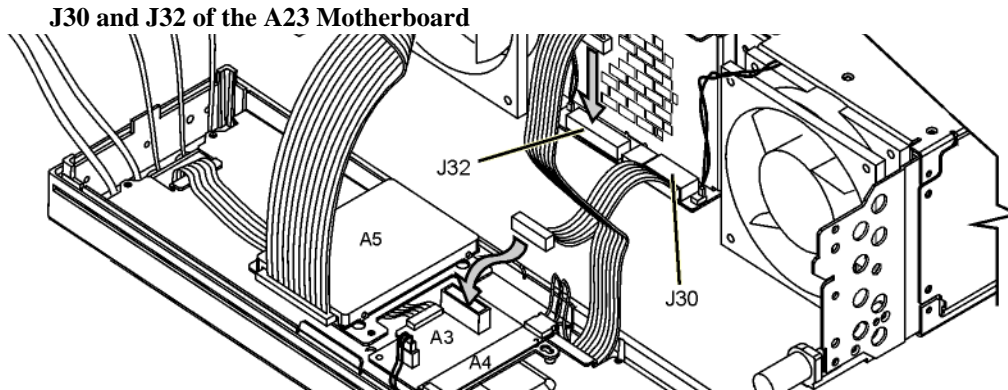

- o Ensure that the signal generator is powered-on, that the front panel green LED is lit, and that the signal generator is not being controlled remotely.
 - If the signal generator is powered-on and the green LED is lit:
 - a. Press the Local hardkey to place the signal generator in local-control mode.
 - b. Press any suspected defective hardkeys or softkeys while monitoring their corresponding KEYCOLx and KEYROWy line at J32 of the A23 Motherboard.
 - If either signal is incorrect, refer to the [Table 1-10](#) and check the signal at J15 on the A23 Motherboard.

J15 is where the signal leaves the A12 CPU.

 - If the signal is incorrect at J15, replace the A12 CPU.
(Refer to [“A12 CPU”](#) on page 3-34.)
 - If both signals at the J32 and J15 connectors are correct, replace the A1 Keyboard.
(Refer to [“A1 Keyboard”](#) on page 3-8.)
- If the signal generator is powered-on and the green LED is not lit, refer to [“Power Supplies”](#) on page 1-21.

Table 1-9 A1 Keyboard Control Lines (KEYCOLx and KEYROWy)

	KEYCOL0 J32-1	KEYCOL1 J32-3	KEYCOL2 J32-5	KEYCOL3 J32-7	KEYCOL4 J32-9	KEYCOL5 J32-11	KEYCOL6 J32-13	KEYCOL7 J32-15
KEYROW0 J32-17	Softkey 3	NA	Cont Up	NA	NA	Mode Menu	Mode Sel	NA
KEYROW1 J32-19	Softkey 2	Incr/Set	Cont Down	Ampl	Ampl Menu	AM	Pulse	Utility
KEYROW2 J32-21	Softkey 1	Up	NA	Freq	Freq Menu	FM/ΦM	Dig Mod	Cal
KEYROW3 J32-23	Softkey 4	NA	NA	Right Arrow	Help	Save	Recall	Trigger
KEYROW4 J32-25	Softkey 6	NA	Local	Hold	Mod On/Off	4	5	6
KEYROW5 J32-26	Softkey 5	NA	Return	Down Arrow	NA	7	8	9
KEYROW6 J32-24	NA	NA	NA	Left Arrow	RF On/Off	0	.	+/-
KEYROW7 J32-22	Softkey 7	NA	Preset	NA	NA	1	2	3

Table 1-10 J15 Control Lines (KEYCOLx and KEYROWy)

KEYROW0	J32-17	J15-111	KEYCOL0	J32-1	J15-46
KEYROW1	J32-19	J15-51	KEYCOL1	J32-3	J15-47
KEYROW2	J32-21	J15-112	KEYCOL2	J32-5	J15-108
KEYROW3	J32-23	J15-52	KEYCOL3	J32-7	J15-48
KEYROW4	J32-25	J15-53	KEYCOL4	J32-9	J15-109
KEYROW5	J32-26	J15-114	KEYCOL5	J32-11	J15-49
KEYROW6	J32-24	J15-54	KEYCOL6	J32-13	J15-110
KEYROW7	J32-22	J15-55	KEYCOL7	J32-15	J15-50

Figure 1-9 J15 of the A23 Motherboard

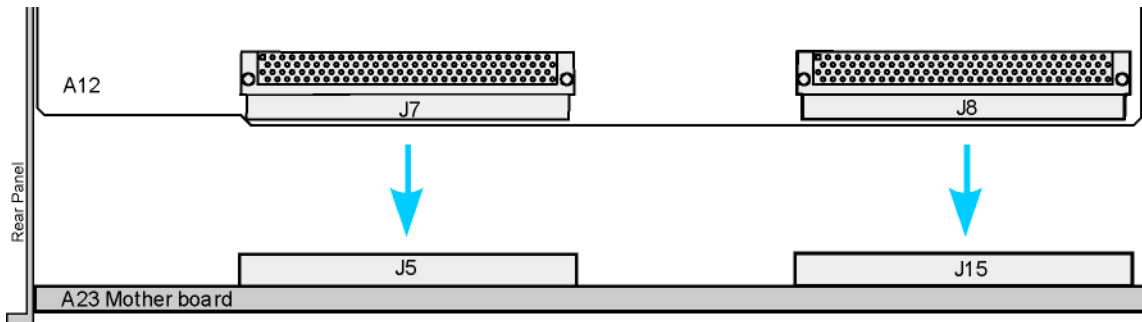

a12_cpu2mthr-bd

Symptom: If the RPG Knob is Not Functioning

When the RPG Knob is functioning properly, DS11 on the A12 CPU should blink each time that the RPG knob is rotated.

Figure 1-10 **Blinking of DS11 Indicates RPG Knob Activity**

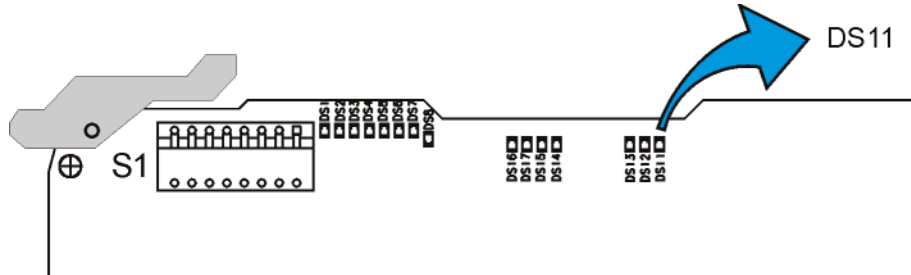

- Ensure that the signal generator is powered-on and that the front panel green LED is lit.
 - If the green LED is lit and the RPG knob is not functioning:
 - a. Check J32-12 for +5.2 VD_LCD.
 - If the voltage is present on J32-12:
 - a. Press the Frequency hardkey on the front panel.
 - b. Using an oscilloscope, monitor J32-14 and J32-10 while rotating the RPG knob.

The display frequency value should change and both signals at J32-14 and J32-10 should pulse to a TTL high.

— If either of the signals do not pulse to a TTL high, replace the A1 Keyboard.
(Refer to “A1 Keyboard” on page 3-8.)

— If the signals are pulsing to a TTL high:

- a. Check the signal at J15-106 and J15-107 of the A23 Motherboard.
 - If the signals are pulsing to a TTL high, replace the A12 CPU.
(Refer to “A12 CPU” on page 3-34.)

— If the voltage is not present on J32-12, refer to “Power Supplies” on page 1-21.

— If the green LED is not lit, refer to “Power Supplies” on page 1-21.

Figure 1-11 **J30 and J32 of the A23 Motherboard**

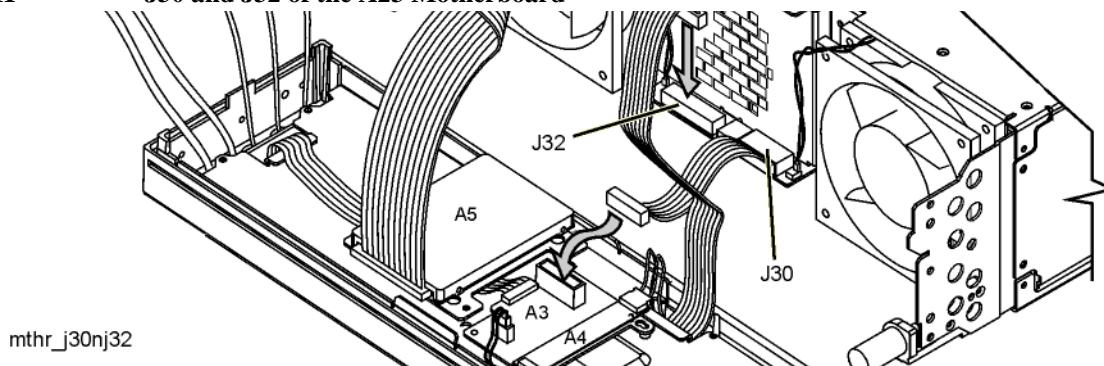

mthr_j30nj32

Symptom: If the Screen Saver is Not Functioning

The screen saver delay may be set for any integer from 1 to 12 hours. The A12 CPU controls the screen saver by pulling the LIGHT_EN line low.

- Ensure that the signal generator is powered-on and that the front panel green LED is lit.
 - If the green LED is lit, the delay time has elapsed, and the display hasn't gone dark:
 - a. Check the LIGHT_EN signal at J30-20. (Refer to [Figure 1-11](#).)
 - If the signal is a TTL low, replace the A4 Inverter. (Refer to [“A4 Inverter” on page 3-19](#).)
 - If the signal is a TTL high:
 - a. Check J15-37 of the A23 Motherboard. (Refer to [Figure 1-9](#).)
 - If the signal is a TTL high, replace the A12 CPU. (Refer to [“A12 CPU” on page 3-34](#).)
 - If the green LED is not lit, refer to [“Power Supplies” on page 1-21](#).

Self-Test Failures and Related Troubleshooting

Overview

The philosophy behind self-test is, “*It is better to pass a defective signal generator than to fail a good signal generator.*” Self-Test is designed as a diagnostic tool used to check signal generator hardware. Self-tests do not require the signal generator to be calibrated before self-tests will pass. This philosophy implies that some failures will not be detected and reported as bad, but will pass. If the signal generator powers on and self-tests can be run, troubleshooting should always start by running self-tests and resolving reported problems first.

Embedded in the signal generator’s firmware is a group of tests (self-tests) that can be used to evaluate the condition of the circuitry on many of the assemblies. Self-tests check hardware performance under controlled conditions and compare test results to predetermined limits. If the results fall within the limits, the signal generator passes. If one or more test results fall outside the limits, the self-test routine evaluates the failures and reports the most independent failure.

1. When the signal generator is tested at the factory, self-test limits are loaded into the A12 CPU memory from devices on each assembly or from fixed files. Most assemblies contain limit information while microcircuit limits must be loaded.
2. When the program runs, latches and DACs are set to a known state.
3. An analog multiplexer routes the detected dc signals from the selected test node to the A12 CPU.
4. The A12 CPU compares the detected dc level to the test limit. If the detected value is within the limits, the A12 CPU reports a pass.
5. If one or more detected values fall outside the limits, the most independent failure is determined and reported.

Independent failures can best be understood by using an example where there are three assemblies in a series: A1 is the first assembly, A2 the second assembly, and A3 the third assembly. A1 output is the input for A2 and A2 output is the input for A3. If A1 output is bad, A2 and A3 outputs are also bad. If A2 output is bad, A3 output is bad.

A file in the signal generator contains this dependency knowledge for the signal generator to use when identifying the most independent failure. If A1, A2, and A3 self-tests all fail, the signal generator reports A1 as the most independent failure. If A1 passes, but A2 and A3 fail, self-test reports A2 as the most independent failure. If A2 passes and A3 fails, self-test reports A3 as the most independent failure. If two independent failures occur, self-test reports only one failure at a time and reports the second failure after the first reported failure is repaired. The troubleshooting procedure is based on the most independent failure and no lower level information is needed. Although not needed for troubleshooting the signal generator, the self-test overhead provides features to view lower level detailed information about the subroutines and select specific routines to run.

These features include:

- Select/Deselect Test
- Select/Deselect All
- Run Highlighted Tests
- Run Selected Tests
- View Details

When View Details is selected, the measured value, lower, and upper limits are displayed on the highlighted test.

Running Self-Test

1. Press the **Utility > Instrument Info/Help Mode > Self Test > Run Complete Self Test.**

Self-Test Failures and Related Troubleshooting

In the following table, the first column lists self-test errors, and the second column points to the section that describes assembly-level troubleshooting procedures related to the self test.

Table 1-11 Self-Test Failures and Related Troubleshooting

If the following self-test fails...	Go to this assembly troubleshooting section...
A10 I/Q Multiplexer (E4438C Only) 100 Power Supply 101 Cal Source 102 ExtIn Offset DAC and Switch 103 Path 1&2 and ExtOut 104 Path1 Atten+Summing Amp 105 Path2 Atten+Summing Amp 106 DC-Coupled Mode Test 107 Drift Canceller Test 108 IQ Polarity Switch 109 RMS to DC Conv Test	“Self-Tests 1xx for the A10 I/Q Multiplexer (E4438C Only)” on page 1-28
A15 Sampler 200 Power Supply 201 Tuning + Bias Test 203 YO Loop Detector	“Self-Tests 2xx for the A15 Sampler” on page 1-30
A13 Output (E4428C Only) 400 Ground and PTAT Test 405 Gain Adjustment Test 406 Prelevel Bypass Test 407 Switched Filters Test 408 ALC Reference Test 409 ALC Modulation Test 410 Burst Modulation Test 411 ALC Detector Test 412 Het Band Test 413 Bulk R DAC Test 414 Log Offset Test	“Self-Tests 4xx for the A13 Output” on page 1-33
A13 Output (E4438C Only) 400 Ground and PTAT Test 401 Prelevel Loop Test 402 Quadrature DAC Test 403 VBLO Test 404 Marble Test 405 Gain Adjustment Test 406 Prelevel Bypass Test 407 Switched Filters Test 408 ALC Reference Test 409 ALC Modulation Test 410 Burst Modulation Test 411 ALC Detector Test 412 Het Band Test 413 Bulk R DAC Test 414 Log Offset Test	“Self-Tests 4xx for the A13 Output” on page 1-33

Table 1-11 Self-Test Failures and Related Troubleshooting (Continued)

If the following self-test fails...	Go to this assembly troubleshooting section...
A17 Synthesizer 500 Power Supply 501 Loop Gain 502 Tuning Voltage 503 RF Detector 504 FM Inversion	“Self-Tests 5xx for the A17 Synthesizer” on page 1-37
A21 YTO Driver 600 Post Regulators 601 DACs Test 602 PLL Interface 603 FM Driver	“Self-Tests 6xx for the A21 YTO Driver” on page 1-40
A16 Frac-N 700 Power Supply 701 Loop Gain 702 Tuning Voltage 703 Output Voltage 704 Filter Test 705 F/2 Test 706 FM Path Test	“Self-Tests 7xx for the A16 Frac-N” on page 1-43
A18 Reference 800 1 GHz Detector 801 Tuning Voltage 802 AM MUX and DACs 803 FM MUX and DACs	“Self-Tests 8xx for the A18 Reference” on page 1-48
A12 CPU 1100 Power Supply	“Self-Tests 11xx for the A12 CPU” on page 1-50
A11 Internal Bit Error Rate Analyzer (E4438C Only) 1400 Power Supply	“Self-Tests 14xx for the A11 Internal Bit Error Rate Analyzer (E4438C Only)” on page 1-52
A9 Digital Demodulator (E4438C Only) 1500 Power Supply	“Self-Tests 15xx for the A9 Digital Demodulator (E4438C Only)” on page 1-54
A7 Baseband Generator (E4438C Only) 1600 Host <-> BBG Comm 1601 Apps1 <-> Apps2 Comm 1602 Apps1 <-> SH4 Comm 1603 Apps2 <-> SH4 Comm 1604 Fliegen <-> Apps2 Comm 1605 SRAM Test 1606 SDRAM Test 1607 Paren <-> SH4 Comm 1608 VCO Tune Test 1609 IQ DAC Output Test 1610 PLL Test	“Self-Tests 16xx for the A7 Baseband Generator (E4438C Only)” on page 1-56

Table 1-11 Self-Test Failures and Related Troubleshooting (Continued)

If the following self-test fails...	Go to this assembly troubleshooting section...
A14 Extended Frequency Output 2000 Ground and PTAT Test 2001 Prelevel Loop Test 2002 Quadrature DAC Test 2003 VBLO Test 2004 Marble Test 2005 Gain Adjustment Test 2006 ALC Reference Test 2007 ALC Modulation Test 2008 Burst Modulation Test 2009 ALC Detector Test 2010 Bulk R DAC Test 2011 Log Offset Test	“Self-Tests 20xx for the A14 Extended Frequency Output” on page 1-59
A23 Motherboard 2100 Power Supply 2101 Sweep Diag 2102 LCD Bias	“Self-Tests 21xx for the A23 Motherboard” on page 1-62

Troubleshooting Assembly Level Problems

WARNING Wait 30 seconds after unplugging the instrument to allow the power supplies to discharge before removing or installing any assemblies.

Power Supplies

The power supply is a switching supply that has an automatic line-voltage and frequency selection. There are no switches to change for 115 Vac or 240 Vac operation. The power line fuse is not replaceable. If the fuse opens, the power supply must be replaced. To troubleshoot the signal generator's power supplies, refer to [Table 1-12](#), [Table 1-13](#), [Table 1-14](#), and [Table 1-15](#).

NOTE Many of the power supplies voltages shown in [Table 1-12](#), [Table 1-13](#), [Table 1-14](#), and [Table 1-15](#) are filtered or regulated on the A23 Motherboard. In some cases, the voltage level may be correct when measured at the A6 Power Supply, but wrong when measured at a destination connector. If this type of situation occurs, it could be due to an open inductor, a shorted capacitor in a filtering circuit, or a bad regulator located on the A23 Motherboard; this would indicate that the A23 Motherboard needs to be changed.

Troubleshooting
Troubleshooting Assembly Level Problems

Table 1-12

A23 Motherboard test points for:	+32	+15	MB LED +12.5^{ab}	MB LED -12.5^{ab}	+9 VF^c Filtered +9	+5.2 VA^c Filtered +5.2 VD	MB LED +5.2 VD^{ac}
A2 Display							
A3 Front Panel Auxiliary Board							
A6 Power Supply	J28-7	J28-25, 36			J28-19, 42	J28-14, 15, 46, 47	J28-14, 15, 46, 47
Slot 1 ^d A7 Baseband Generator (E4438C Only)	J11-4	J11-28				J11-2, 27	J1-64, 65, 129, 130
Slot 2 A9 Digital Demodulator (E4438C Only)	J12-4	J12-28				J12-2, 27	J2-64, 65, 129, 130
Slot 3 A10 I/Q Multiplexer (E4438C Only)	J13-4	J13-28				J13-2, 27	J3-64, 65, 129, 130
Slot 4 A11 Internal Bit Error Rate Analyzer (E4438C Only)		J14-28				J14-2, 27	J4-64, 65, 129, 130
Slot 5 A12 CPU	J15-44	J15-103			J15-58	J15-42	J5-59, 60, 119, 120
A19 Daughterboard	J10-83	J10-32, 82			J10-34, 84	J10-30, 31, 80, 81	
A20 Downconverter							
A21 YTO Driver							
A25 Rear Panel Board or A26 Rear Panel LVDS Board (Option 1EM) and A27 Rear Panel SMB Board (Option 1EM)							
AT1 Electronic Attenuator or AT1 High-Power Mechanical Attenuator and A28 Reverse Power Protection		J25-1 J25-1 J22-5	J25-14 J25-14 J22-3	J25-13 J25-13 J22-4			J25-15 J25-15
B1 Power Supply Fan							
B2 Small Fan							
B3 Daughterboard/Card Cage Fan							

- a. MB LED means that an LED for this power supply is visible from the top-side of the A23 Motherboard.
- b. The voltage regulator for this power supply is located on the A23 Motherboard.
- c. The voltage for this power supply is filtered on the A23 Motherboard.
- d. Slot numbers one through five (where one is on the left) refer to the position of an assembly in the top card-cage of the signal generator when viewed from the top.

Table 1-13

A23 Motherboard test points for:	MB LED +3.4 VDF^a	MB LED +2.6 VD_1^{ab}	MB LED +2.6 VD_2^{ab}	Self-Test Node +1.8 VD_1^{bc}	Self-Test Node +1.8 VD_2^{bc}	Self-Test Node +1.95 VD_1^{bc}	Self-Test Node +1.95 VD_2^{bc}
A2 Display							
A3 Front Panel Auxiliary Board							
A6 Power Supply	J28-1, 2, 5, 6, 9, 10, 51, 52, 55, 56, 59, 60						
Slot 1 A7 Baseband Generator (E4438C Only)	J1-60, 61, 62, 63, 125, 126, 127, 128	J1-57, 58, 59, 123, 124		J1-55, 56, 120, 121, 122		J1-52, 118	
Slot 2 A9 Digital Demodulator (E4438C Only)	J2-60, 61, 62, 63, 125, 126, 127, 128		J2-57, 58, 59, 123, 124		J2-55, 56, 120, 121, 122		J2-52, 118
Slot 3 A10 I/Q Multiplexer (E4438C Only)	J3-60, 61, 62, 63, 125, 126, 127, 128		J3-57, 58, 59, 123, 124				
Slot 4 A11 Internal Bit Error Rate Analyzer (E4438C Only)	J4-60, 61, 62, 63, 125, 126, 127, 128	J4-57, 58, 59, 123, 124					
Slot 5 A12 CPU	J5-55, 56, 57, 58, 115, 116, 117, 118						
A19 Daughterboard							
A20 Downconverter							
A21 YTO Driver							
A25 Rear Panel Board or A26 Rear Panel LVDS Board (Option 1EM) and A27 Rear Panel SMB Board (Option 1EM)	J36-1						
AT1 Electronic Attenuator or AT1 High-Power Mechanical Attenuator and A28 Reverse Power Protection							
B1 Power Supply Fan							
B2 Small Fan							
B3 Daughterboard/Card Cage Fan							

- a. MB LED means that an LED for this power supply is visible from the top-side of the A23 Motherboard.
- b. The voltage regulator for this power supply is located on the A23 Motherboard.
- c. Self-Test Node means that the voltage for this power supply is measured from the analog bus during Self-Test.

Troubleshooting
Troubleshooting Assembly Level Problems

Table 1-14

A23 Motherboard test points for:	MB LED -6 VF^{ab}	-15 VF^b	MB LED -5.2 VF^{ab}	+15 STBY	+15 STBY LCD^c	+5.2 VD LCD^b	Fan +8.5 to +12 Vdc
	Filtered -6	Filtered -15	Filtered -5.2		Filtered +15.2 STBY	Filtered +5.2 VD	
A2 Display						J32-12	
A3 Front Panel Auxiliary Board					J30-31	J30-32	
A6 Power Supply	J28-38	J28-23	J28-21, 40	J28-34			
Slot 1 ^d A7 Baseband Generator (E4438C Only)		J11-3	J11-1, 26				
Slot 2 A9 Digital Demodulator (E4438C Only)		J12-3	J12-1, 26				
Slot 3 A10 I/Q Multiplexer (E4438C Only)		J13-3	J13-1, 26				
Slot4 A11 Internal Bit Error Rate Analyzer (E4438C Only)		J14-3	J14-1, 26				
Slot 5 A12 CPU	J15-57	J15-43	J15-101	J15-102			
A19 Daughterboard	J10-37, 87	J10-36, 86	J10-35, 85	J10-33			
A20 Downconverter							
A21 YTO Driver							
A25 Rear Panel Board or A26 Rear Panel LVDS Board (Option 1EM) and A27 Rear Panel SMB Board (Option 1EM)							
AT1 Electronic Attenuator or AT1 High-Power Mechanical Attenuator and A28 Reverse Power Protection							
B1 Power Supply Fan							J33-1
B2 Small Fan							J27-1
B3 Daughterboard/Card Cage Fan							J29-1

- a. MB LED means that an LED for this power supply is visible from the top-side of the A23 Motherboard.
- b. The voltage for this power supply is filtered on the A23 Motherboard.
- c. The voltage for this power supply is generated by filtering the +15_STBY on the A23 Motherboard.
- d. Slot numbers one through five (where one is on the left) refer to the position of an assembly in the top card-cage of the signal generator when viewed from the top.

Table 1-15

A23 Motherboard test points for:	+32 VY ^a	+15 VY ^a	+5.2 VY ^a	+3.4 VDY ^a	+5.2 VDY ^a	-15 VY ^a	-5.2 VY ^a
	Filtered +32 VF	Filtered +15 VF	Filtered +5.2 VA	Filtered +3.4 VDF	Filtered +5.2 VD	Filtered -15 VF	Filtered -5.2 VF
A2 Display							
A3 Front Panel Auxiliary Board							
A6 Power Supply							
Slot 1 ^b A7 Baseband Generator (E4438C Only)							
Slot 2 A9 Digital Demodulator (E4438C Only)							
Slot 3 A10 I/Q Multiplexer (E4438C Only)							
Slot 4 A11 Internal Bit Error Rate Analyzer (E4438C Only)							
Slot 5 A12 CPU							
A19 Daughterboard							
A20 Downconverter	J26-14	J26-13	J26-12				
A21 YTO Driver	J34-55, 57	J34-54, 56	J34-51	J34-45	J34-44	J34-49	J34-50
A25 Rear Panel Board or A26 Rear Panel LVDS Board (Option 1EM) and A27 Rear Panel SMB Board (Option 1EM)							
AT1 Electronic Attenuator or AT1 High-Power Mechanical Attenuator and A28 Reverse Power Protection							
B1 Power Supply Fan							
B2 Small Fan							
B3 Daughterboard/Card Cage Fan							

- a. The voltage for this power supply is filtered on the A23 Motherboard.
b. Slot numbers one through five (where one is on the left) refer to the position of an assembly in the top card-cage of the signal generator when viewed from the top.

Troubleshooting Assembly Level Problems

If the Amber Standby LED is Not Working

With the power turned off and the signal generator plugged in, the front panel amber standby LED should be on. The amber Standby LED is controlled by a +15 Vdc standby line supplied by the power supply, which is routed through the A23 Motherboard to the front panel.

To troubleshoot the +15 Vdc Standby line, turn the signal generator off and follow the signal path. Refer to [Table 1-12](#), [Table 1-13](#), [Table 1-14](#), and [Table 1-15](#).

If the Green Line Power LED is Not Working

When the power switch is turned on, the amber LED goes out and the green LED comes on. The fans start rotating and the front panel display becomes illuminated.

To troubleshoot, refer to [Table 1-12](#), [Table 1-13](#), [Table 1-14](#), and [Table 1-15](#) and verify the power supply voltages at J28 of the A23 Motherboard. If the supply voltages are correct, replace the A3 Front Panel Auxiliary Board. (Refer to “[A3 Front Panel Auxiliary Board](#)” on page 3-17.)

If the Fans are Not Working

There are three fans located near the front of the instrument that are connected to the A23 Motherboard. The fan control voltages are supplied by the A6 Power Supply and may be measured at J28 of the A23 Motherboard. The fan control voltage range is +8.5 Vdc (at 23 degrees C) to +12.0 Vdc (at 55 degrees C). At higher temperatures, the fan voltage increases along with the rotation of the fan.

To troubleshoot, disconnect each fan (one at a time) from the A23 Motherboard and check the fan voltage. Refer to [Table 1-12](#), [Table 1-13](#), [Table 1-14](#), and [Table 1-15](#). If the fan voltage is correct, replace the fan. (Refer to “[B1 Power Supply Fan](#)” on page 3-76, “[B2 Small Fan](#)” on page 3-78, or “[B3 Daughterboard/Card Cage Fan](#)” on page 3-80.)

If the Signal Generator Does Not Power-on and the Power Supply LEDs are Not Working

Each of the power supplies has an LED located on the bottom of the A23 Motherboard. If the power supply is functioning, the green LED is on. Use a voltmeter to measure the supplies on the A23 Motherboard to ensure the voltages meet the power supply specifications in the following table.

With the exceptions of the +15 Vdc and the +15 Vdc Standby power supply, each power supply should have a maximum of 10 mV_{p-p} ripple. The +15 Vdc and the +15 Vdc Standby power supply have a maximum ripple specification of 20 mV_{p-p}. The ripple can be measured using an oscilloscope. If any of the supplies LEDs are not on or the measured voltage is less than the acceptable value, one of the assemblies may be loading down the power supply. To find where each power supply is used, refer to [Table 1-12](#), [Table 1-13](#), [Table 1-14](#), and [Table 1-15](#).

To troubleshoot and isolate a defective assembly, turn power off to the signal generator and remove one of the assemblies being biased by the faulty power supply.

Power Supply	Acceptable Voltage
+32 Vdc	32.0 ± 0.96 Vdc
+15 Vdc	15.0 ± 0.45 Vdc
+15 Vdc Standby	15.0 ± 0.45 Vdc
+9.0 Vdc	9.0 ± 0.27 Vdc
+5.2 Vdc	5.2 ± 0.16 Vdc
+3.3 Vdc	3.3 ± 0.10 Vdc
-6.0 Vdc	-6.0 ± 0.18 Vdc
-15 Vdc	-15.0 ± 0.45 Vdc

NOTE It is important to have a minimum number of assemblies removed at one time. The power supply expects to see a minimum load, otherwise the power supply voltage will increase until an over-voltage condition exists.

Turn power back on to the signal generator and check the suspected faulty power supply. If the condition is still bad, turn power off to the signal generator and re-install the first assembly that was removed. Remove one of the other assemblies being

biased by the faulty power supply and see if the problem is alleviated. Continue this process until the power supply is functioning properly. Replace the last assembly that was removed.

If the Front Panel Power Switch is Not Functioning

When the front-panel power switch is switched on, the control line (ON/OFF) from the A1 Keyboard is momentarily grounded and the A6 Power Supply is enabled. The ON/OFF signal is routed from the A1 Keyboard through J32-20 to the A23 Motherboard. Circuitry on the A23 Motherboard uses the ON/OFF signal to generate the Pwr_On_L. This line is routed to the A6 Power Supply and the A12 CPU; the A6 Power Supply is disabled when the Pwr_On_L line is a TTL high or open.

To troubleshoot

1. Measure J28-34 with a DVM to assure that the +15 Vdc Standby voltage (+15 STBY) is correct.
 - If the +15 Vdc Standby voltage is good, use the DVM to measure J32-20 (ON/OFF). The DVM should read approximately +5 Vdc.
 - a. While monitoring the DVM, depress and hold the front panel power switch. This grounds the ON/OFF signal and the DVM should read less than a few millivolts.
 - b. Release the front panel power switch. The ON/OFF control signal should again be approximately +5 Vdc.
2. With the front panel power switch off, the Pwr_On_L line at J28-32 of the A23 Motherboard should be at approximately +5.8 Vdc; this signal is generated on the A23 Motherboard.
 - If the voltage is less than +3.5 Vdc, remove the A6 Power Supply and measure the resistance of the connection from J28-32 to ground; the impedance should be ≥ 1 Megaohm.
 - If the impedance is correct, replace the A6 Power Supply.
3. When the front panel power switch is turned on, the Pwr_On_L line goes to $< +50$ mV.
 - If the A1 Keyboard is functioning properly and the Pwr_On_L line is not, replace the A23 Motherboard.
 - If the Pwr_On_L line is functioning properly, replace the A6 Power Supply.

Self-Tests 1xx for the A10 I/Q Multiplexer (E4438C Only)

Figure 1-12

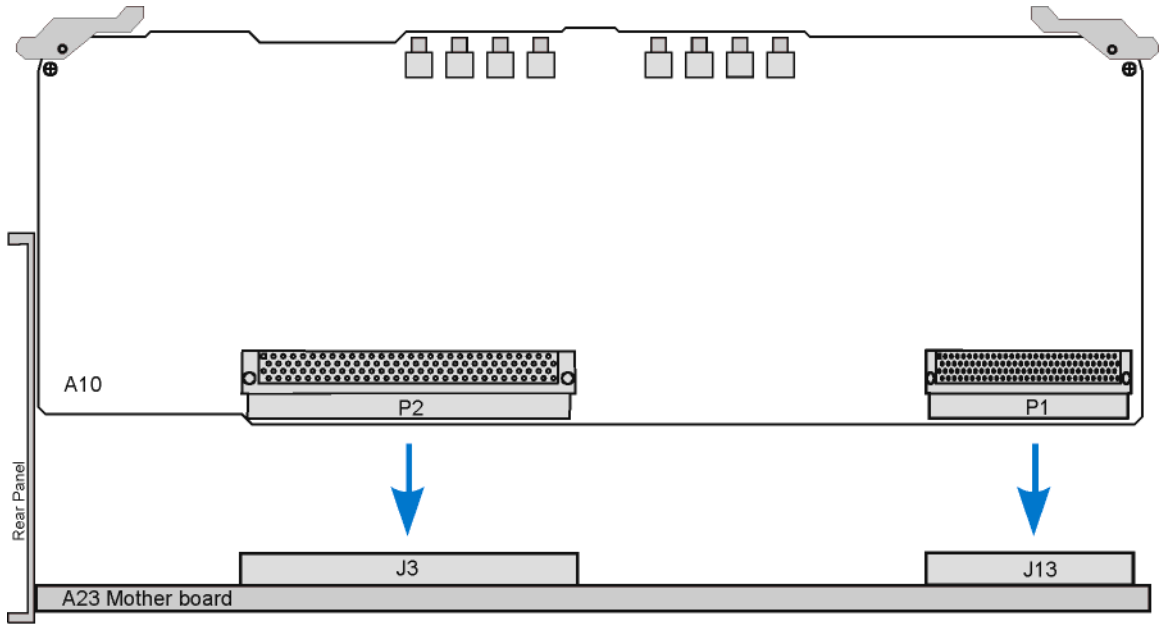

a10_iq-std2mthr-bd

Table 1-16

Power Supply Voltage (Vdc)	Connector Pins on the A23 Motherboard	Minimum Value (Vdc)	Maximum Value (Vdc)	Origin
+15	J13-28	14.55	15.45	Main Supply
-15	J13-3	-15.45	-14.55	Main Supply
+5.2	J13-2, 27	5.044	5.356	Main Supply
-5.2	J13-1, 26	-5.356	-5.044	Main Supply
+5 VD	J3-64, 65, 129, 130	5.044	5.356	Main Supply

100 Power Supply

- If the power supply voltages are good on the connector pins indicated:
 - a. Remove the A10 I/Q Multiplexer and measure the resistance of the connection between the appropriate pins of J3/J13 (A23 Motherboard side) and sockets of J3/J13 (A10 I/Q Multiplexer side).
 - b. If the connection is good, replace the A10 I/Q Multiplexer. (Refer to [“A10 I/Q Multiplexer \(E4438C Only\)” on page 3-30.](#))
 - c. If the connection is bad, replace the A23 Motherboard. (Refer to [“A23 Motherboard” on page 3-56.](#))
- If the supply voltages are bad on any of the connector pins indicate:
 - a. Check the origin of the power supply.
 - b. If the power supply voltages are good at the origin, replace the A23 Motherboard. (Refer to [“A23 Motherboard” on page 3-56.](#))
 - c. If the power supply voltages are bad at the origin, troubleshoot the problem using the assembly’s troubleshooting procedure.

101 Cal Source

- Replace the A10 I/Q Multiplexer.

102 ExtIn Offset DAC and Switch

- Replace the A10 I/Q Multiplexer.

103 Path1&2 and ExtOut

- Replace the A10 I/Q Multiplexer.

104 Path1 Atten+Summing Amp

- Replace the A10 I/Q Multiplexer.

105 Path2 Atten+Summing Amp

- Replace the A10 I/Q Multiplexer.

106 DC-Coupled Mode Test

- Replace the A10 I/Q Multiplexer.

107 Drift Canceller Test

- Replace the A10 I/Q Multiplexer.

108 IQ Polarity Switch

- Replace the A10 I/Q Multiplexer.

109 RMS to DC Conv Test

- Replace the A10 I/Q Multiplexer.

Self-Tests 2xx for the A15 Sampler

Figure 1-13

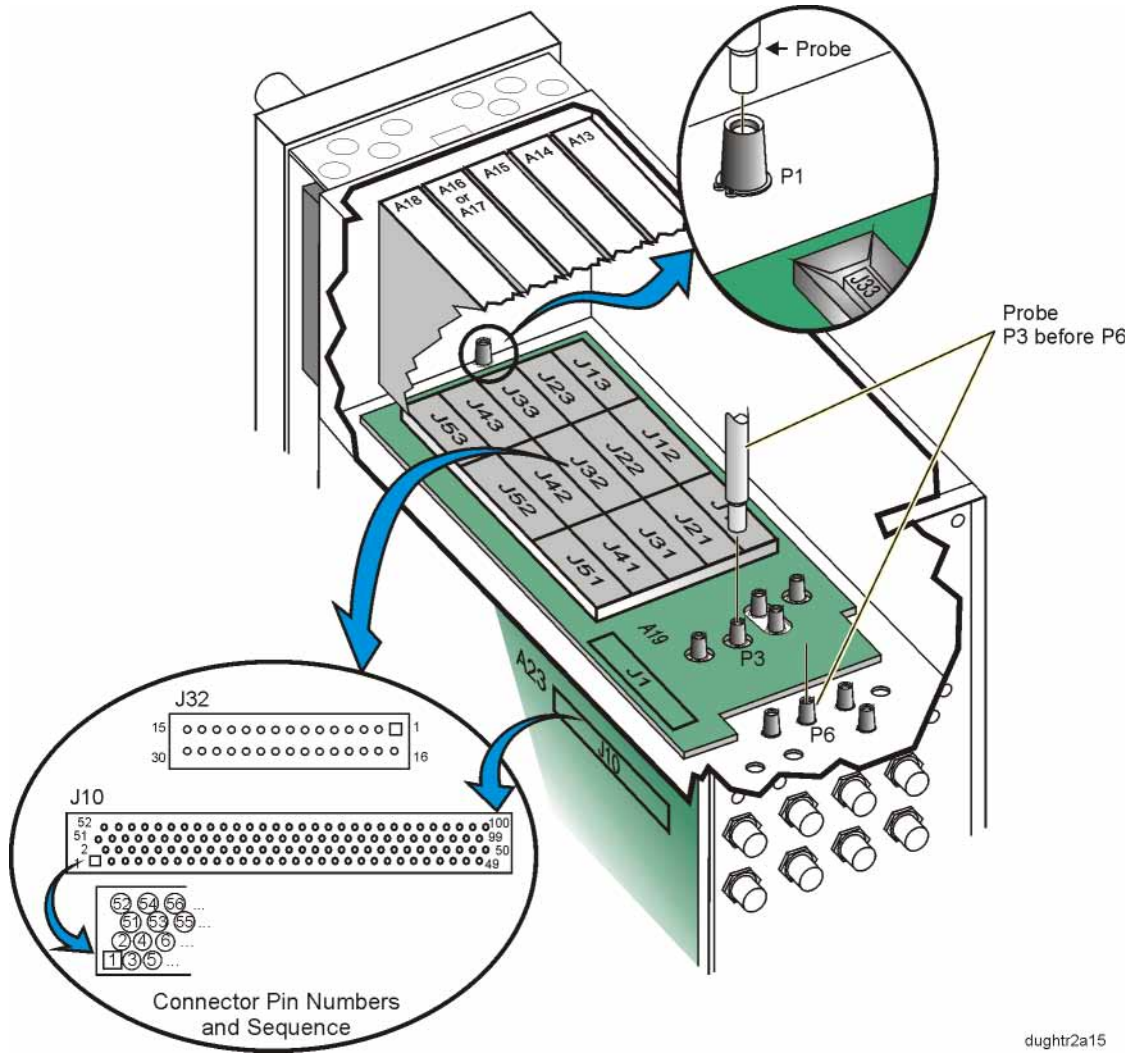

Table 1-17

Power Supply Voltage (Vdc)	Connector Pins on the		Minimum Value (Vdc)	Maximum Value (Vdc)	Origin
	A19 Daughterboard	A23 Motherboard			
+32	J32-7	J10-83	+31.04	+32.96	Main Supply
+15	J32-6, 21	J10-32, 82	+14.1	+15.9	Main Supply
-15	J32-2, 17	J10-36, 86	-15.9	-14.1	Main Supply
+9	J32-5, 20	J10-34, 84	+8.73	+9.27	Main Supply
+5.2 VD	J32-14, 29	J10-35, 85	+4.68	+5.72	Main Supply

200 Power Supply

- If the supply voltages are good on the J10 connector pins indicated:
 - a. Turn power off to the signal generator.
 - b. Remove the A15 Sampler and measure the resistance of the connection between the appropriate J32 and J10 pins.
 - If the connection is good, replace the A15 Sampler. (Refer to “A15 Sampler” on page 3-40.)
 - If the connection is bad, replace the A19 Daughterboard (Refer to “A19 Daughterboard” on page 3-48).
- If the supply voltages are bad on the J10 connector pins indicated:
 - a. Check the origin of the supply.
 - If the supply voltages are good at the origin, replace the A23 Motherboard. (Refer to “A23 Motherboard” on page 3-56.)
 - If the supply voltages are bad at the origin, troubleshoot the problem using that assembly’s troubleshooting procedure.

201 Tuning + Bias Test

CAUTION Do not install the A18 Reference or the A15 Sampler with the signal generator powered up or serious damage to the signal generator may be caused.

- With the signal generator powered up, carefully remove the A15 Sampler from the signal generator.
- Connect a semi-rigid cable-extender probe to P1 and connect a signal analyzer to the probe.

P1 delivers a 1 GHz signal from J3 of the A18 Reference to J1 of the A15 Sampler through W44.
- Check for a 1 GHz signal with a power level ≥ 0 dBm.
 - If the signal is present and at the correct power, replace the A15 Sampler. (Refer to “A15 Sampler” on page 3-40.)
 - If the signal is not present or at the correct power:
 - a. Turn power off to the signal generator.
 - b. Remove the A18 Reference.
 - c. Measure the resistance of the center pin of W44; it should measure as a short.
 - d. Measure the resistance between the center pin and the shield of W44; it should measure as an open.
 - If the cable measures good (as defined in the previous two steps), refer to the A18 Reference troubleshooting procedure.
 - If the cable measures bad, replace the cable.

203 YO Loop Detector

CAUTION Do not install the A13 Output with the signal generator powered up or serious damage to the signal generator may be caused.

- With the signal generator powered up, carefully remove the A15 Sampler from the signal generator.
- Set the signal generator to a frequency of 625 MHz.
- Connect a semi-rigid cable-extender probe to P3 and connect a signal analyzer to the probe.

P3 delivers the YTO output signal from J8 of the A21 YTO Driver to J3 of the A15 Sampler through W37.

- Check for a 5 GHz (± 5 MHz) signal at a power level > -10 dBm.
 - If the signal is present and at the correct power:
 - a. Connect a semi-rigid cable-extender probe to P6 and connect a signal analyzer to the probe.

P6 delivers the VCO output signal from J2 of the A16 Frac-N to J6 of the A15 Sampler through W11.
 - b. Set the signal generator to a frequency of 625 MHz.
 - c. Check for an 859.375 MHz signal at a power level $\geq +5$ dBm.
 - If the signal is good, replace the A15 Sampler. (Refer to “A15 Sampler” on page 3-40.)
 - If the signal is bad, refer to the A16 Frac-N troubleshooting procedure.
 - If the signal is not present or at the correct power, refer to the A21 YTO Driver troubleshooting procedure.

Self-Tests 4xx for the A13 Output

Figure 1-14

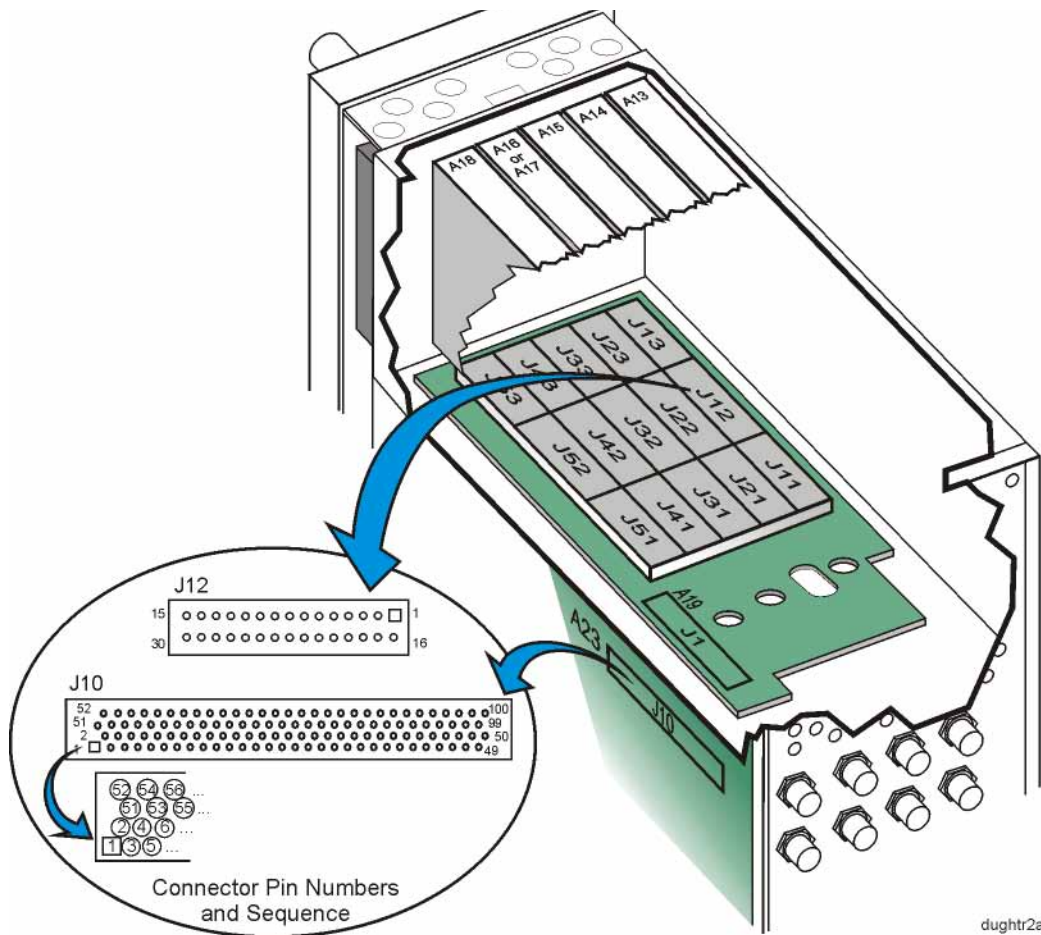

Table 1-18

Power Supply Voltage (Vdc)	Connector Pins on the		Minimum Value (Vdc)	Maximum Value (Vdc)	Origin
	A19 Daughterboard	A23 Motherboard			
+15	J12-6, 21	J10-32, 82	+14.1	+15.9	Main Supply
-15	J12-2, 17	J10-36, 86	-15.9	-14.1	Main Supply
+5.2	J12-14, 29	J10-30, 31, 80, 81	+4.68	+5.72	Main Supply
+9	J12-5, 20	J10-34, 84	+8.73	+9.27	Main Supply
-6	J12-3, 18	J10-37, 87	-6.36	-5.64	Main Supply
-5.2	J12-4, 19	J10-35, 85	-5.356	-5.044	Main Supply

400 Ground and PTAT Test

- Using a DVM, measure the voltages on J10 (the PTAT voltage is derived from the ± 15 Vdc):
 - If the supply voltages are good on the J10 connector pins indicated:
 - a. Turn off the power and remove the A13 Output.
 - b. Measure the resistance of the connection between the appropriate pins of J12 and J10.
 - If the connection is good, replace the A13 Output. (Refer to “A13 Output” on page 3-36.)
 - If the connection is bad, replace the A19 Daughterboard. (Refer to “A19 Daughterboard” on page 3-48.)
 - If the supply voltages are bad on any of the J10 connector pins indicated:
 - a. Check the origin of the supply.
 - If the supply voltages are good at the origin, replace the A23 Motherboard. (Refer to “A23 Motherboard” on page 3-56.)
 - If the supply voltages are bad at the origin, troubleshoot the problem using that assembly's troubleshooting procedure.

401 Prelevel Loop Test (E4438C Only)

CAUTION Do not install the A13 Output with the signal generator powered up or serious damage to the signal generator may be caused.

- With the signal generator powered up, carefully remove the A13 Output from the signal generator.
- Set the signal generator to a frequency of 900 MHz.
- At J4 of the A13 Output, connect a spectrum analyzer to the A16 Frac-N or A17 Synthesizer RF output and measure the signal; it should be 900 MHz at an amplitude ≥ 5 dBm.
 - If the signal is not present or at the correct amplitude, refer to the A16 Frac-N or A17 Synthesizer troubleshooting.
 - If the signal is present, replace the A13 Output. (Refer to “A13 Output” on page 3-36.)

402 Quadrature DAC Test (E4438C Only)

- Replace the A13 Output.

403 VBLO Test (E4438C Only)

- Replace the A13 Output.

404 IQ Test (E4438C Only)

- Measure the Q signal from the A10 I/Q Multiplexer.
 - a. Disconnect the cable from J3 of the A19 Daughterboard and connect it to a DVM.
 - b. Set the CW frequency to 2 GHz.
 - c. Turn on the I/Q modulation and adjust the Q offset.
 - d. Press: **I/Q > I/Q On > I/Q Adjustments > I/Q Adjustments On > Q Offset**
 - e. Rotate the RPG and observe the DVM. The voltage should vary from approximately +0.25 Vdc for an offset of 50% to approximately -0.25 Vdc for an offset of -50%.
 - If the signal is bad, check it at J10 of the A10 I/Q Multiplexer.
 - If the signal is bad at J10, refer to A10 I/Q Multiplexer troubleshooting.
 - If the signal is good at J10, change the cable.
- Measure the I signal from the A10 I/Q Multiplexer.
 - a. Disconnect the cable from J2 of the A19 Daughterboard and connect it to a DVM.
 - b. Set the CW frequency to 2 GHz.
 - c. Turn on the I/Q modulation and adjust the I offset.
 - d. Press: **I/Q > I/Q On > I/Q Adjustments > I/Q Adjustments On > I Offset**
 - e. Rotate the RPG and observe the DVM. The voltage should vary from approximately +0.25 Vdc for an offset of 50% to approximately -0.25 Vdc for an offset of -50%.
 - If the signal is bad, check it at J9 of the A10 I/Q Multiplexer.
 - If the signal is bad at J9, refer to A10 I/Q Multiplexer troubleshooting.
 - If the signal is good at J9, change the cable.
- If the I and Q signals are good, replace the A13 Output. (Refer to [“A13 Output” on page 3-36.](#))

405 Gain Adjustment Test

- Replace the A13 Output.

406 Prelevel Bypass Test

- Replace the A13 Output.

407 Switched filters Test

- Replace the A13 Output.

408 ALC Reference Test

- Replace the A13 Output.

409 ALC Modulation Test

- Replace the A13 Output.

410 Burst Modulation Test

- Replace the A13 Output.

411 ALC Detector Test

- Replace the A13 Output.

412 Het Band Test

- Measure the 1 GHz signal from the A18 Reference.
 - a. With the power off, remove the A13 Output and insert a ribbon cable extender into J11 of the A19 Daughterboard.
 - b. Power on the signal generator and tune to a CW frequency of 200 MHz.
 - c. Using a spectrum analyzer, probe pin 19 of the ribbon cable extender¹ for a 1 GHz signal with an amplitude > -20 dBm:
 - If the signal is present, replace the A13 Output. (Refer to “A13 Output” on page 3-36.)
 - If the signal is not present, power down the signal generator and remove the A18 Reference. (Refer to “A18 Reference” on page 3-46.)
 - d. Using a DVM, measure the resistance between J11-19 and J51-19:
 - If the path is open, replace the A19 Daughterboard. (Refer to “A19 Daughterboard” on page 3-48.)
 - If the path is good (zero ohms), refer to the A18 Reference troubleshooting for the 1 GHz VCO.

413 Bulk R DAC Test

- Replace the A13 Output.

414 Log Offset Test

- Replace the A13 Output.

1. The ribbon cable extender needs to be assembled by the user. It consists of two connector plugs (part number 1252-1010) and approximately eight inches of ribbon cable (part number 8120-2226). The ribbon cable contains 26 wires; six of these wires need to be stripped off before being connected to the plugs.

Self-Tests 5xx for the A17 Synthesizer

Figure 1-15

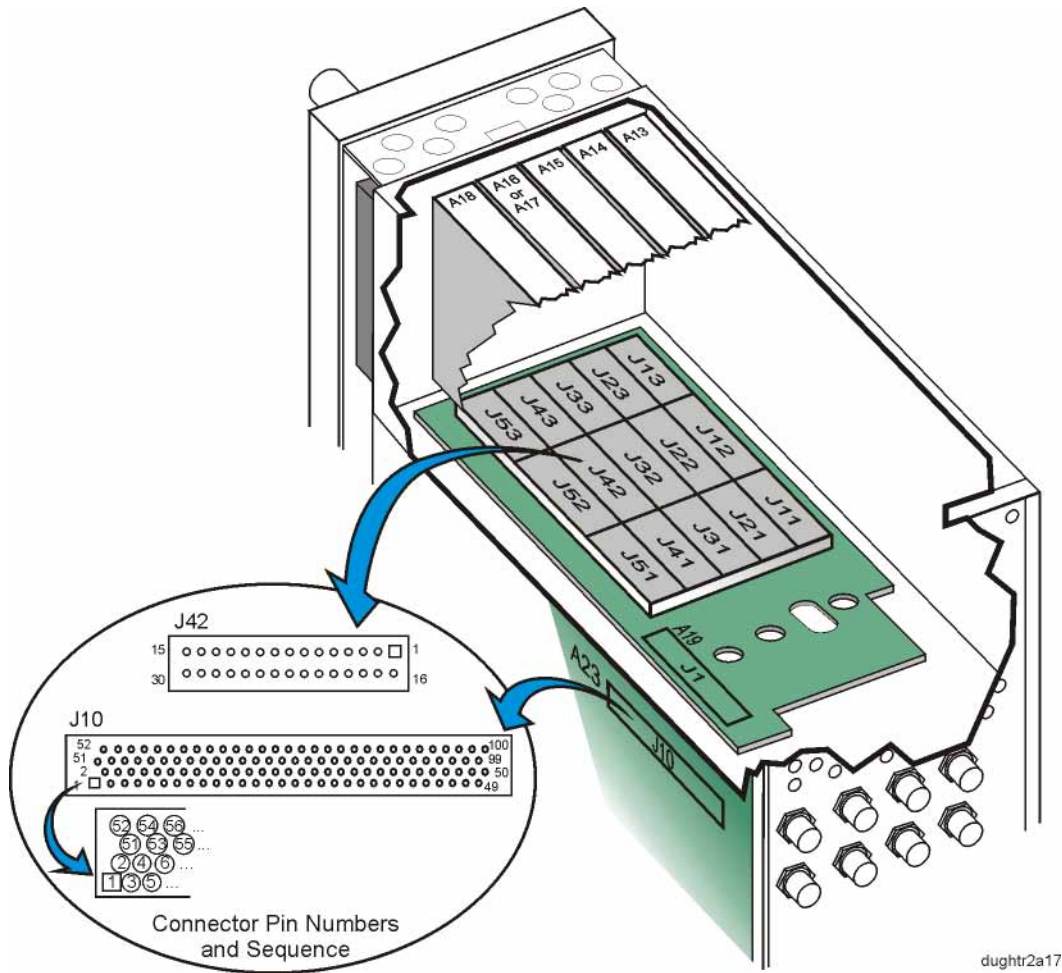

Table 1-19

Power Supply Voltage (Vdc)	Connector Pins on the		Minimum Value (Vdc)	Maximum Value (Vdc)	Origin
	A19 Daughterboard	A23 Motherboard			
+32	J42-7	J10-83	+31.04	+32.96	Main Supply
+15	J42-6, 21	J10-32, 82	+14.1	+15.9	Main Supply
-15	J42-2, 17	J10-36, 86	-15.9	-14.1	Main Supply
+9	J42-5, 20	J10-34, 84	+8.73	+9.27	Main Supply
-6	J42-3, 18	J10-37, 87	-6.36	-5.64	Main Supply
-5.2	J42-4, 19	J10-35, 85	-5.356	-5.044	Main Supply
+5.2	J42-14, 29	J10-30, 31, 80, 81	+4.68	+5.72	Main Supply

500 Power Supply

- If the ± 15 V and +5.2 V supplies are good on the connector pins indicated:
 - a. Turn power off, remove the A17 Synthesizer and measure the resistance of the connection between the appropriate J42 and J10 pins.
 - If the connection is good, replace the A17 Synthesizer. (Refer to “A17 Synthesizer” on page 3-44.)
 - If the connection is bad, replace the A19 Daughterboard. (Refer to “A19 Daughterboard” on page 3-48.)
- If the ± 15 V and +5.2 V supplies are bad on the connector pins indicated:
 - a. Check the origin of the supply.
 - If the supply voltage is good at the origin, replace the A23 Motherboard. (Refer to “A23 Motherboard” on page 3-56.)
 - If the supply voltage is bad at the origin, troubleshoot the problem using that assembly's troubleshooting procedure.

501 Loop Gain

- Replace the A17 Synthesizer.

502 Tuning Voltage

- If the +32 V and +9 V supplies are good on the connector pins indicated:
 - a. Turn power off, remove the A17 Synthesizer, and measure the resistance of the connection between the appropriate J42 and J10 pins.
 - If the connection is good:
 - a. Re-insert the A17 Synthesizer.
 - b. Turn power on and check the 10 MHz signal on the A23 Motherboard at J10 pin 99 using an oscilloscope.

The signal should have a period of 100 ns and an amplitude of greater than 1.2 Vp-p.

 - If the signal is good, replace the A17 Synthesizer. (Refer to “A17 Synthesizer” on page 3-44.)
 - If the signal is bad, troubleshoot the A18 Reference. (Refer to “A18 Reference” on page 3-46.)
 - If the connection is bad replace the A19 Daughterboard. (Refer to “A19 Daughterboard” on page 3-48.)
- If the +32 V and +9 V supplies are bad on the connector pins indicated:
 - a. Check the origin of the supply.
 - If the supply voltage is good at the origin, replace the A23 Motherboard. (Refer to “A23 Motherboard” on page 3-56.)
 - If the supply voltage is bad at the origin, troubleshoot the problem using that assembly's troubleshooting procedure.

503 RF Detector

- If the -6 V supply is good on the connector pins indicated:
 - a. Turn power off, remove the A17 Synthesizer and measure the resistance of the connection between the appropriate J52 and J10 pins.
 - If the connection is good, replace the A17 Synthesizer. (Refer to [“A17 Synthesizer” on page 3-44.](#))
 - If the connection is bad, replace the A19 Daughterboard. (Refer to [“A19 Daughterboard” on page 3-48.](#))
- If the -6 V supply is bad on the connector pins indicated:
 - a. Check the origin of the supply.
 - If the supply voltage is good at the origin, replace the A23 Motherboard. (Refer to [“A23 Motherboard” on page 3-56.](#))
 - If the supply voltage is bad at the origin, troubleshoot the problem using that assembly's troubleshooting procedure.

504 FM Inversion

- Replace the A17 Synthesizer.

Self-Tests 6xx for the A21 YTO Driver

Figure 1-16

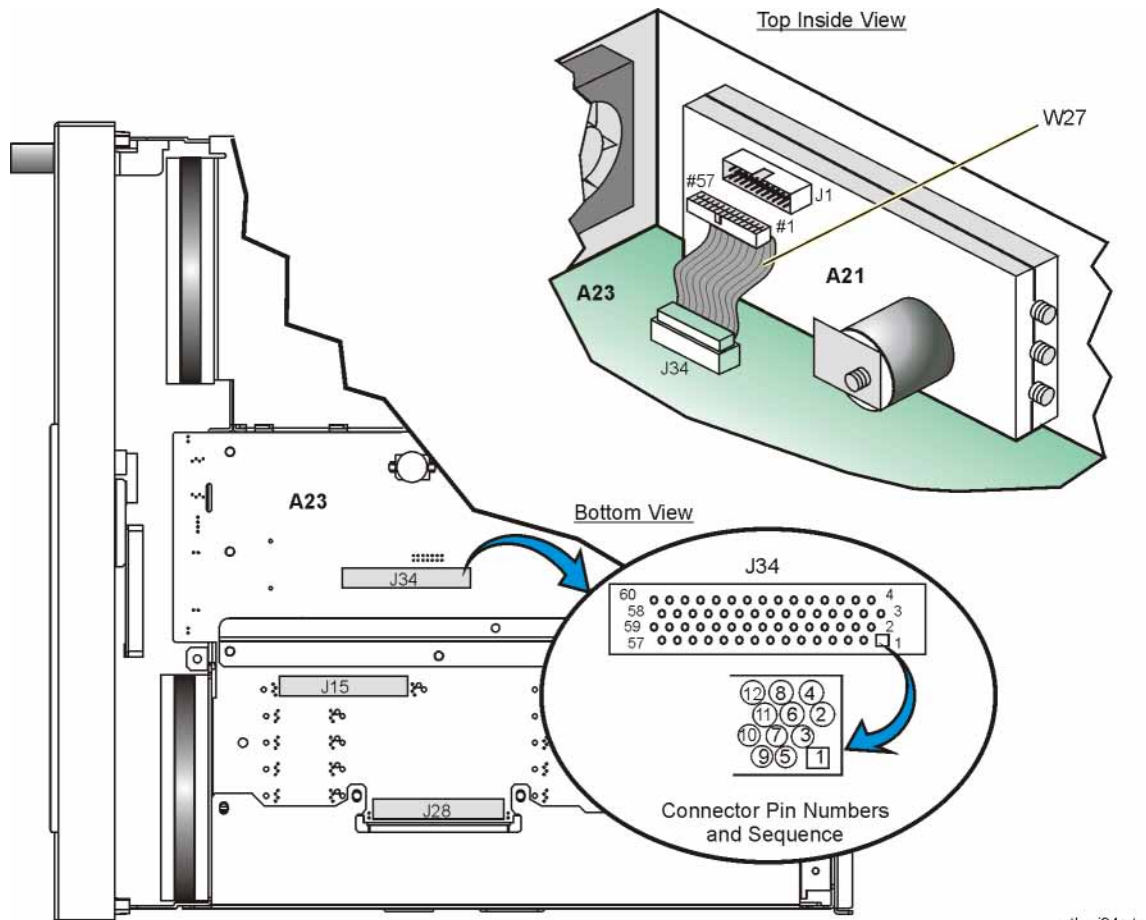

mthr_j34-ytc

Table 1-20

Power Supply Voltage (Vdc)	Connector Pins on the		Minimum Value (Vdc)	Maximum Value (Vdc)	Origin
	A21 YTO Driver	A23 Motherboard			
+32	J1-55, 57	J34-55, 57	+31.04	+32.96	Main Supply
+15	J1-54, 56	J34-54, 56	+14.1	+15.9	Main Supply
-15	J1-49	J34-49	-15.9	-14.1	Main Supply
-5.2	J1-50	J34-50	-5.356	-5.044	Main Supply
+5.2	J1-51	J34-51	+4.68	+5.72	Main Supply
+5.2 VD	J1-44	J34-44	+4.68	+5.72	Main Supply
+3.4 VDY	J1-45	J34-45	+3.298	+3.502	Main Supply

600 Post Regulators

- If the +5.2 VD, +3.4 VDY, and ± 15 V supplies are good on the J34 connector pins indicated:
 - a. Remove the W27 ribbon cable from J1 of the A21 YTO Driver.
 - b. Measure the +5.2 VD, +3.4 VDY, and ± 15 V supplies on the appropriate pins of the W27 ribbon cable.
 - If the voltages are good, replace the A21 YTO Driver. (Refer to [“A21 YTO Driver and A22 Coupler” on page 3-54.](#))
 - If the voltages are bad:
 - a. Remove the W27 ribbon cable from the J34 connector on the A23 Motherboard.
 - b. On W27, measure the resistance between the appropriate pins from one end of the cable to the other.
 - If the pins on W27 measure good (indicated as zero ohms), replace the A23 Motherboard. (Refer to [“A23 Motherboard” on page 3-56.](#))
 - If the pins on W27 measure bad (indicated as infinite ohms), replace the W27 cable.
- If the +5.2 VD, +3.4 VDY, and ± 15 V supplies are bad on the J34 connector pins indicated:
 - a. Check the origin of the supply.
 - If the supply voltage is good at the origin, replace the A23 Motherboard. (Refer to [“A23 Motherboard” on page 3-56.](#))
 - If the supply voltage is bad at the origin, troubleshoot the problem using that assembly's troubleshooting procedure.

601 DACs Test

- If the +32 V, +5.2 V, and -5.2 V supplies are good on the J34 connector pins indicated:
 - a. Remove the W27 ribbon cable from J1 of the A21 YTO Driver.
 - b. Measure the +32 V, +5.2 V, and -5.2 V supplies on the appropriate pins of the W27 ribbon cable.
 - If the voltages are good, replace the A21 YTO Driver. (Refer to [“A21 YTO Driver and A22 Coupler” on page 3-54.](#))
 - If the voltages are bad:
 - a. Remove the W27 ribbon cable from the J34 connector on the A23 Motherboard.
 - b. On W27, measure the resistance between the appropriate pins from one end of the cable to the other.
 - If the pins on W27 measure good (indicated as zero ohms), replace the A23 Motherboard. (Refer to [“A23 Motherboard” on page 3-56.](#))
 - If the pins on W27 measure bad (indicated as infinite ohms), replace the W27 cable.
- If the +32 V, +5.2 V, and -5.2 V supplies are bad on the J34 connector pins indicated:
 - a. Check the origin of the supply.
 - If the supply voltage is good at the origin, replace the A23 Motherboard. (Refer to [“A23 Motherboard” on page 3-56.](#))
 - If the supply voltage is bad, troubleshoot the problem using that assembly's procedure.

602 PLL Interface

- Check for A15 Sampler YO phase lock interference.
 - a. Disconnect the cable from J4 of the A21 YTO Driver.
 - If test 602 still fails, replace the A21 YTO Driver. (Refer to “A21 YTO Driver and A22 Coupler” on page 3-54.)
 - If test 602 passes, troubleshoot the A15 Sampler. (Refer to “A15 Sampler” on page 3-40.)

603 FM Driver

- Measure the FM modulation signal from the A16 Frac-N.
 - a. Disconnect the cable at J3 of the A21 YTO Driver.
 - b. Select the FM/φM menu.
 - c. Select the following:
 - FM mode
 - FM Path 1
 - FM Dev 100 kHz
 - FM Source (Internal)
 - FM Rate 400 Hz
 - More (1 of 2) >> FM Waveform (Square)
 - FM On
 - d. Select Mode On/Off to On.
 - e. Use an oscilloscope and probe the center pin of W28 (the cable that connects to J3 of A21 YTO Driver) to measure a 400 Hz square-wave signal with an amplitude > 2 Vp-p.
 - If the signal is good, replace the A21 YTO Driver. (Refer to “A21 YTO Driver and A22 Coupler” on page 3-54.)
 - If the signal is bad, turn power off and remove the A15 Sampler and A16 Frac-N.
 - a. Measure the resistance of the center pin connection between W28 and J14 of the A19 Daughterboard.

This should be a short.
 - b. Measure the resistance of the connection between the center pin of W28 and ground.

This should be an open.

 - If the connections are bad, check the W28 cable.
 - If the W28 cable is good, replace the A19 Daughterboard. (Refer to “A19 Daughterboard” on page 3-48.)
 - If the connections are good, troubleshoot the A16 Frac-N.

Self-Tests 7xx for the A16 Frac-N

Figure 1-17

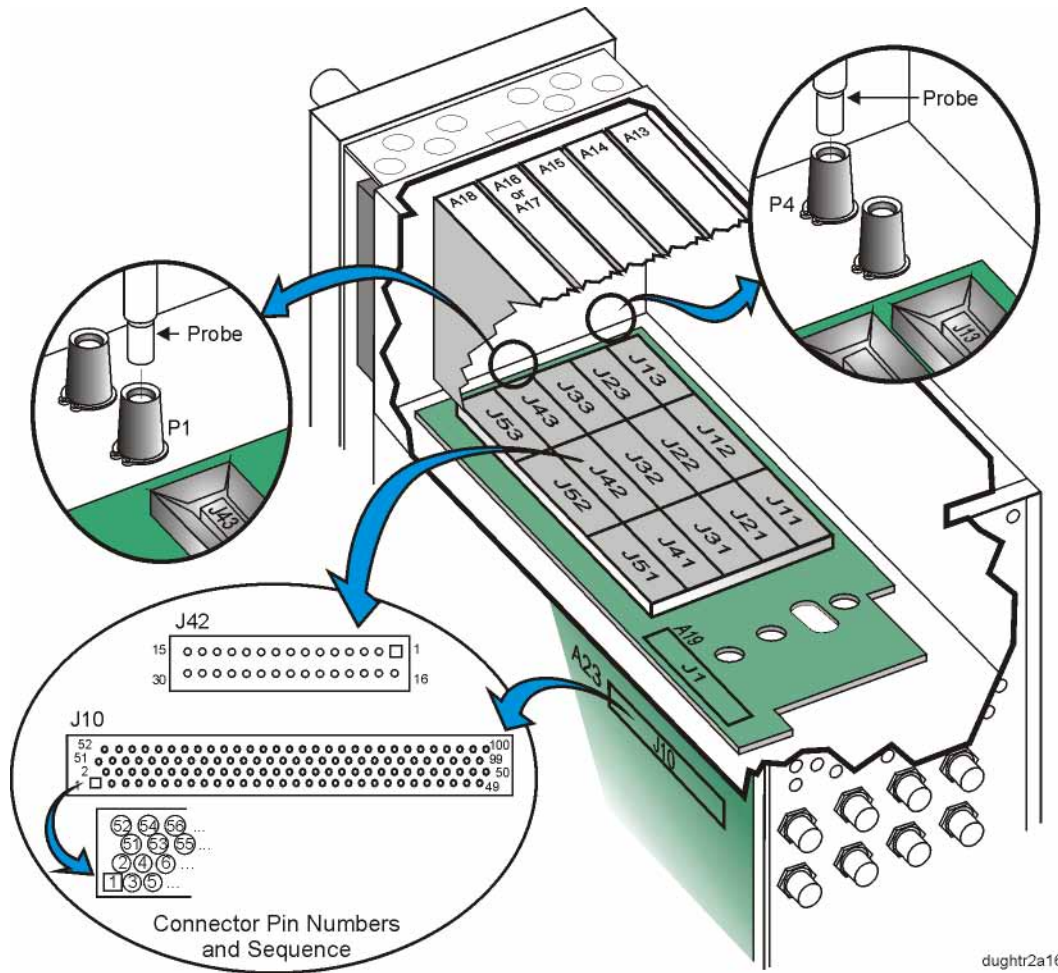

dughtr2a16

Table 1-21

Power Supply Voltage (Vdc)	Connector Pins on the		Minimum Value (Vdc)	Maximum Value (Vdc)	Origin
	A19 Daughterboard	A23 Motherboard			
+32	J42-7	J10-83	+31.04	+32.96	Main Supply
+15	J42-6, 21	J10-32, 82	+14.1	+15.9	Main Supply
-15	J42-2, 17	J10-36, 86	-15.9	-14.1	Main Supply
+9	J42-5, 20	J10-34, 84	+8.73	+9.27	Main Supply
-6	J42-3, 18	J10-37, 87	-5.64	-6.36	Main Supply
-5.2	J42-4, 19	J10-35, 85	-5.356	-5.044	Main Supply
+5.2	J42-14, 29	J10-30, 31, 80, 81	+4.68	+5.72	Main Supply

700 Power Supply

- If the +5.2 V, +15 V, and –15 V supplies are good on the connector pins indicated:
 - a. Turn power off to the signal generator.
 - b. Remove the A16 Frac-N and measure the resistance of the connection between the appropriate J42 and J10 pins.
 - If the connection is good, replace the A16 Frac-N. (Refer to “A16 Frac-N” on page 3-42.)
 - If the connection is bad, replace the A19 Daughterboard. (Refer to “A19 Daughterboard” on page 3-48.)
- If the +5.2 V, +15 V, and –15 V supplies are bad on the connector pins indicated:
 - a. Check the origin of the supply.
 - If the supply voltage is good at the origin, replace the A23 Motherboard. (Refer to “A23 Motherboard” on page 3-56.)
 - If the supply voltage is bad at the origin, troubleshoot the problem using that assembly’s troubleshooting procedure.

701 Loop Gain

- Replace the A16 Frac-N.

702 Tuning Voltage

- If the +32 V, –5.2 V, and +9 V supplies are good on the connector pins indicated:
 - a. Turn power off to the signal generator.
 - b. Remove the A16 Frac-N and measure the resistance of the connection between the appropriate J42 and J10 pins.
 - If the connection is good:
 - a. Re-insert the A16 Frac-N.
 - b. Turn power on to the signal generator.
 - c. Check the 10 MHz signal on the A23 Motherboard at J10 pin 99 using an oscilloscope.

The signal should have a period of 100 ns and an amplitude greater than 1.2 V_{p-p}.

 - If the signal is good, replace the A16 Frac-N. (Refer to “A16 Frac-N” on page 3-42.)
 - If the signal is bad, troubleshoot the A18 Reference.
 - If the connection is bad, replace the A19 Daughterboard. (Refer to “A19 Daughterboard” on page 3-48.)
- If the +32 V, –5.2 V, and +9 V supplies are bad on the connector pins indicated:
 - a. Check the origin of the supply.
 - If the supply voltage is good at the origin, replace the A23 Motherboard. (Refer to “A23 Motherboard” on page 3-56.)
 - If the supply voltage is bad at the origin, troubleshoot the problem using that assembly’s troubleshooting procedure.

703 Output Voltage

- Replace the A16 Frac-N.

704 Filter Test

- If the -6 V supply is good on the connector pins indicated:
 - a. Turn power off to the signal generator.
 - b. Remove the A16 Frac-N and measure the resistance of the connection between the appropriate J42 and J10 pins.
 - If the connection is good:
 - a. Re-insert the A16 Frac-N.
 - b. Remove the A13 Output.
 - c. Turn power on to the signal generator.
 - d. Connect a semi-rigid cable-extender probe to P4 and connect a signal analyzer to the probe; P4 delivers the RF output of the A16 Frac-N through W41.

To locate W41, refer to [“Semi-Rigid Cables - Includes the A21 YTO Driver and the AT1 Electronic Attenuator or the AT1 High-Power Mechanical Attenuator \(Option UNB\) with A28 Reverse Power Protection” on page 2-45.](#)

- e. Tune the signal generator to the following frequencies and check for the presence of a signal:

Table 1-22

Options	Tune (MHz)	Check (MHz)	Level (dBm)
All	300	300 ± 10	> +5
All	500	500 ± 10	> +5
All	900	900 ± 10	> +5
502/503/504/506	1300	1300 ± 10	> +5
503/504/506	2250	2250 ± 10	> +5
503/504/506	3000	3000 ± 10	> +5

- If these signals are good, replace the A16 Frac-N.

Troubleshooting Assembly Level Problems

- If these signals are bad, carefully remove the A16 Frac-N with the power on.
 - a. Connect a semi-rigid cable-extender probe to P1 and connect a signal analyzer to the probe; P1 delivers the YO input of the A16 Frac-N through W38.

To locate W38, refer to [“Semi-Rigid Cables - Includes the A21 YTO Driver and the AT1 Electronic Attenuator or the AT1 High-Power Mechanical Attenuator \(Option UNB\) with A28 Reverse Power Protection” on page 2-45.](#)

- b. Tune the signal generator to the following frequencies and check for the presence of a signal:

Table 1-23

Options	Tune (MHz)	Check (MHz)	Level (dBm)
All	300	4800 ± 300	> -10
All	500	8000 ± 300	> -10
All	900	7200 ± 300	> -10
502/503/504/506	1300	5200 ± 300	> -10
503/504/506	2250	4500 ± 300	> -10
503/504/506	3000	6000 ± 300	> -10

- If these signals are good, replace the A16 Frac-N. (Refer to [“A16 Frac-N” on page 3-42.](#))
- If these signals are bad, replace the A21 YTO Driver. (Refer to [“A21 YTO Driver and A22 Coupler” on page 3-54.](#))
 - If the connection is bad, replace the A19 Daughterboard. (Refer to [“A19 Daughterboard” on page 3-48.](#))
- If the -6 V supply is bad on the connector pins indicated:
 - a. Check the origin of the supply.
 - If the supply voltage is good at the origin, replace the A23 Motherboard. (Refer to [“A23 Motherboard” on page 3-56.](#))
 - If the supply voltage is bad at the origin, troubleshoot the problem using that assembly's troubleshooting procedure.

705 F/2 Test

- Replace the A16 Frac-N.

706 FM Path Test

- Measure the FM modulation signal from the A18 Reference.
 - a. Turn power off to the signal generator.
 - b. Remove the A16 Frac-N and insert a ribbon cable extender¹ into J41 of the A19 Daughterboard.
 - c. Turn power on to the signal generator.
 - d. Select the FM/φM menu.
 - e. Select the following:
 - FM mode
 - FM Path 1
 - FM Dev 100 kHz
 - FM Source (Internal)
 - FM Rate 400 Hz
 - More (1 of 2) >> FM Waveform (Square)
 - FM On
 - f. Select Mode On/Off to On.
 - g. Use an oscilloscope and probe pin 11 of the ribbon cable extender to measure a 400 Hz square-wave signal with an amplitude > 4 Vp-p.
 - If the signal is good, replace the A16 Frac-N. (Refer to [“A16 Frac-N” on page 3-42.](#))
 - If the signal is bad, turn power off and remove the A18 Reference. (Refer to [“A18 Reference” on page 3-46.](#))
 - a. Measure the resistance of the connection between J41-11 and J53-11 of the A19 Daughterboard.

This should be a short.
 - b. Measure the resistance of the connection between J41-11 and ground.

This should be an open.

 - If the connections are bad, replace the A19 Daughterboard. (Refer to [“A19 Daughterboard” on page 3-48.](#))
 - If the connections are good, troubleshoot the A18 Reference.

1. The ribbon cable extender needs to be assembled by the user. It consists of two connector plugs (part number 1252-1010) and approximately eight inches of ribbon cable (part number 8120-2226). The ribbon cable contains 26 wires; six of these wires need to be stripped off before being connected to the plugs.

Self-Tests 8xx for the A18 Reference

Figure 1-18

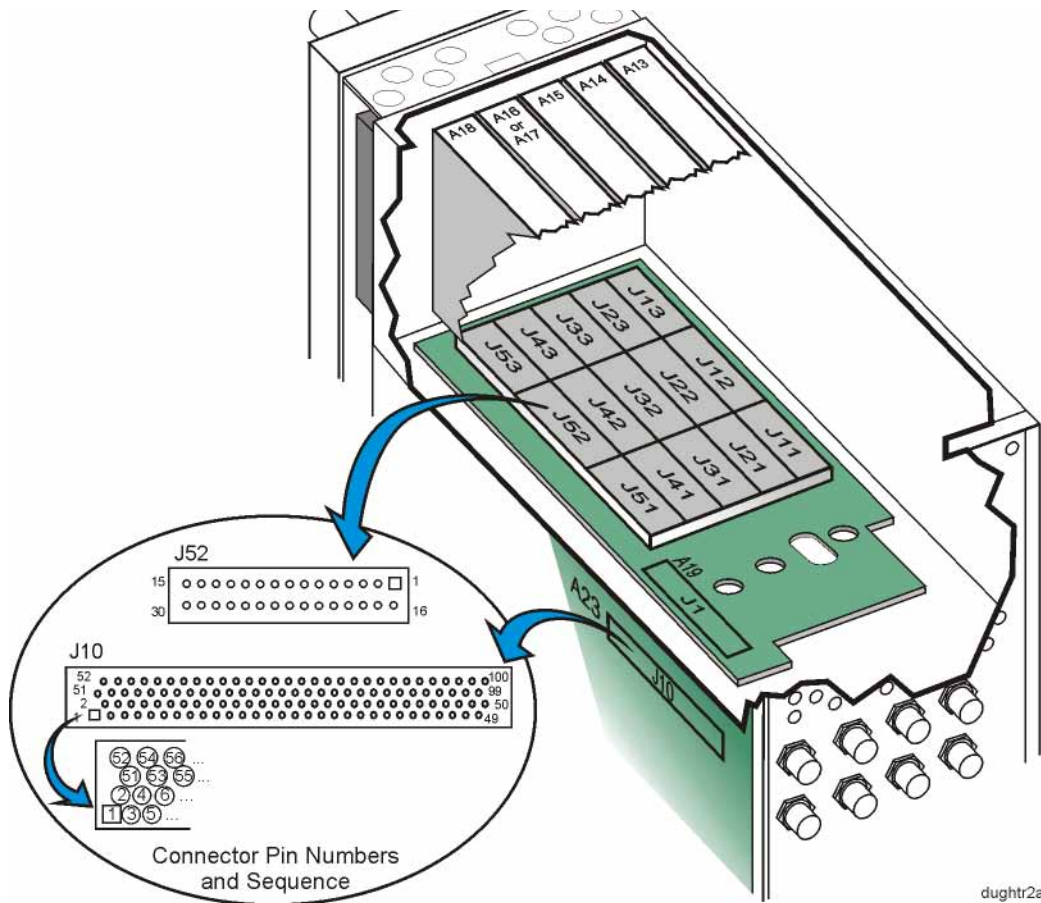

dughtr2a18

Table 1-24

Power Supply Voltage (Vdc)	Connector Pins on the		Minimum Value (Vdc)	Maximum Value (Vdc)	Origin
	A19 Daughterboard	A23 Motherboard			
+32	J52-7	J10-83	+31.04	+32.96	Main Supply
+15	J52-6, 21	J10-32, 82	+14.1	+15.9	Main Supply
-15	J52-2, 17	J10-36, 86	-15.9	-14.1	Main Supply
-5.2	J52-4, 19	J10-35, 85	-5.356	-5.044	Main Supply
+5.2	J52-14, 29	J10-30, 31, 80, 81	+4.68	+5.72	Main Supply
+15 STBY	J52-26	J10-33	+14.55	+15.45	Main Supply

800 1 GHz Detector

- Replace the A18 Reference.

801 Tuning Voltage

- If the supply voltages are good on the J10 connector pins indicated:
 - a. Turn power off to the signal generator.
 - b. Remove the A18 Reference and measure the resistance of the connection between the appropriate J52 and J10 pins.
 - If the connection is good, replace the A18 Reference. (Refer to [“A18 Reference” on page 3-46.](#))
 - If the connection is bad, replace the A19 Daughterboard. (Refer to [“A19 Daughterboard” on page 3-48.](#))
- If the supply voltages are bad on the J10 connector pins indicated:
 - a. Check the origin of the supply.
 - If the supply voltage is good at the origin, replace the A23 Motherboard. (Refer to [“A23 Motherboard” on page 3-56.](#))
 - If the supply voltage is bad at the origin, troubleshoot the problem using that assembly's troubleshooting procedure.

802 AM Mux and DACs

- Replace the A18 Reference.

803 FM Mux and DACs

- Replace the A18 Reference.

Self-Tests 11xx for the A12 CPU

Figure 1-19

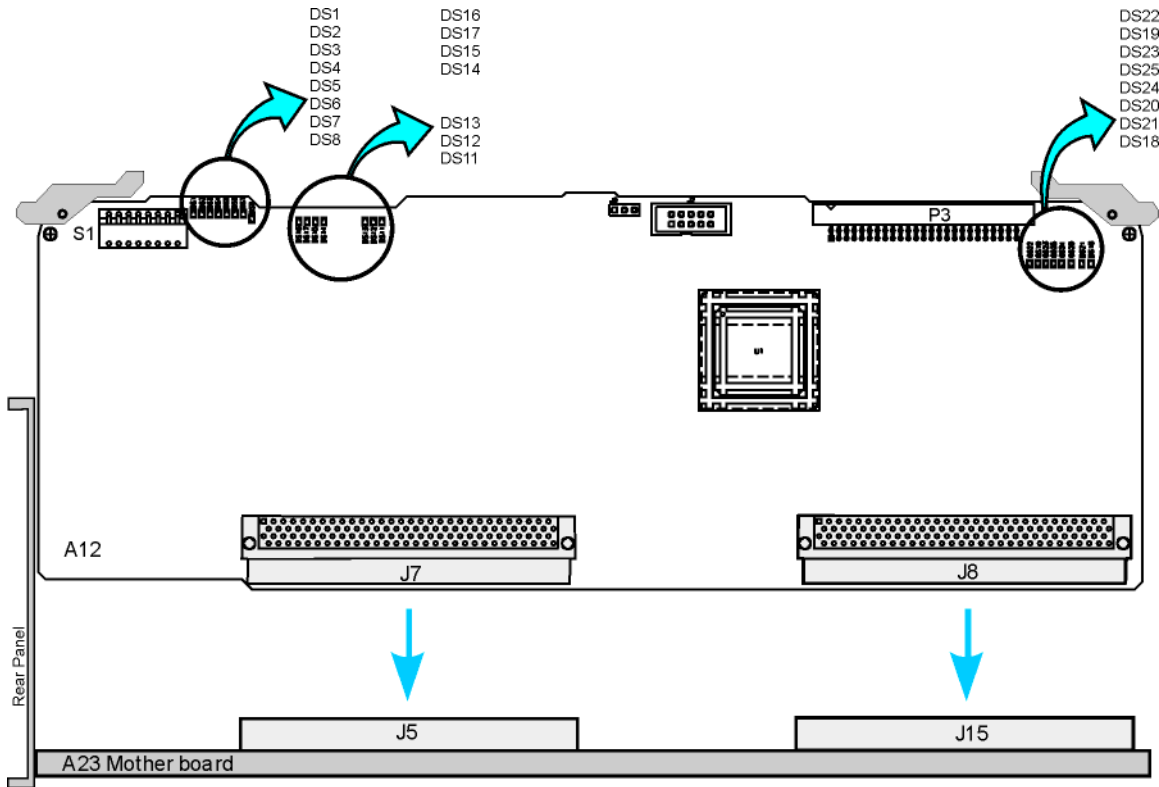

a12_cpu2mthr-bd

Table 1-25

Power Supply Voltage (Vdc)	Connector Pins on the		Minimum Value (Vdc)	Maximum Value (Vdc)	Origin
	A12 CPU	A23 Motherboard			
+32	J8-44	J15-44	+31.04	+32.96	Main Supply
+15	J8-103	J15-103	+14.55	+15.45	Main Supply
-15	J8-43	J15-43	-15.45	-14.55	Main Supply
+9	J8-58	J15-58	+8.73	+9.27	Main Supply
-6	J8-57	J15-57	-6.18	-5.82	Main Supply
-5.2	J8-101	J15-101	-5.356	-5.044	Main Supply
+5.2	J7-59, 60, 119, 120	J5-59, 60, 119, 120	+5.044	+5.356	Main Supply
+3.4	J7-55, 56, 57, 58, 115, 116, 117, 118	J5-55, 56, 57, 58, 115, 116, 117, 118	+3.298	+3.502	Main Supply

1100 Power Supply

- Run the Self-Test to verify that the A12 CPU is receiving the following power supplies: +10 V Ref, -6 V Ref, -5.2 V Ref, and the +9 V Ref.
 - If the power supply voltages are correct on the J15 and J5 connector pins indicated:
 - a. Measure the resistance of the connection between the connectors J8 and J15, or J7 and J5.
 - If the connection is good, replace the A12 CPU. (Refer to [“A12 CPU” on page 3-34.](#))
 - If the connection is bad, replace the A23 Motherboard. (Refer to [“A23 Motherboard” on page 3-56.](#))
 - If the power supply voltages are incorrect on the J15 and J5 connector pins indicated:
 - a. Check the origin of the power supply.
 - If the power supply voltages are good at the origin, replace the A23 Motherboard. (Refer to [“A23 Motherboard” on page 3-56.](#))
 - If the power supply voltages are bad, troubleshoot the problem using the assembly’s troubleshooting procedure.

Self-Tests 14xx for the A11 Internal Bit Error Rate Analyzer (E4438C Only)

Figure 1-20

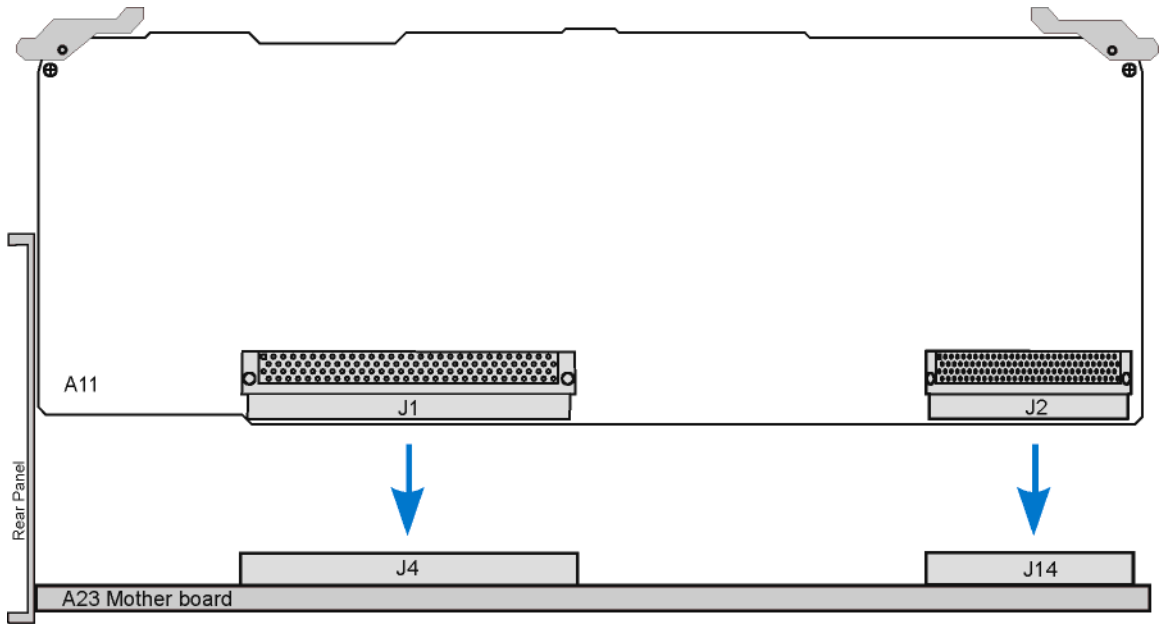

a11_bert2mthr-bd

Table 1-26

Power Supply Voltage (Vdc)	Connector Pins on the A23 Motherboard	Minimum Value (Vdc)	Maximum Value (Vdc)	Origin
+15	J14-28	+14.55	+15.45	Main Supply
-15	J14-3	-15.45	-14.55	Main Supply
-5.2	J14-1, 26	-5.356	-5.044	Main Supply
+5.2 VD	J4-64, 65	+5.044	+5.356	Main Supply
+3.4 VD	J4-60, 61, 62, 63	+3.298	+3.502	Main Supply
+2.6 VD	J4-57, 58, 59	+2.425	+2.575	A23 Motherboard

1400 Power Supply

- If the supply voltages are good on the connector pins indicated:
 - a. Turn power off to the signal generator.
 - b. Remove the A11 Internal Bit Error Rate Analyzer and measure the resistance of the connection between the appropriate pins of J14/J4, and sockets J14/J4.
 - If the connection is good, replace the A11 Internal Bit Error Rate Analyzer. (Refer to [“A11 Internal Bit Error Rate Analyzer \(E4438C Only\)”](#) on page 3-32.)
 - If the connection is bad, replace the A23 Motherboard. (Refer to [“A23 Motherboard”](#) on page 3-56.)
- If the supply voltages are bad on the connector pins indicated:
 - a. Check the origin of the supply.
 - If the supply voltage is good at the origin, replace the A23 Motherboard. (Refer to [“A23 Motherboard”](#) on page 3-56.)
 - If the supply voltage is bad at the origin, troubleshoot the problem using that assembly's troubleshooting procedure.

Self-Tests 15xx for the A9 Digital Demodulator (E4438C Only)

Figure 1-21

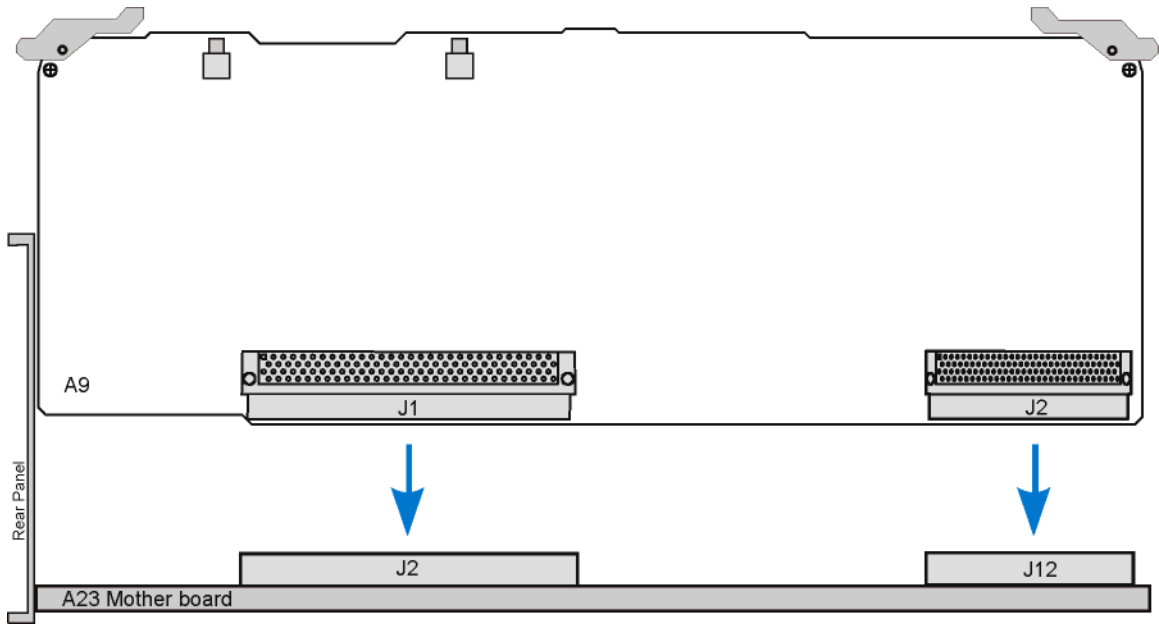

a9_demod2mthr-bd

Table 1-27

Power Supply Voltage (Vdc)	Connector Pins on the A23 Motherboard	Minimum Value (Vdc)	Maximum Value (Vdc)	Origin
+15	J12-28	+14.55	+15.45	Main Supply
-15	J12-3	-15.45	-14.55	Main Supply
-5.2	J12-1, 26	-5.356	-5.044	Main Supply
+5.2	J12-2, 27	+5.044	+5.356	Main Supply
+5.2 VD	J2-64, 65	+5.044	+5.356	Main Supply
+3.4 VD	J2-60, 61, 62, 63	+3.298	+3.502	Main Supply
+2.6 VD	J2-57, 58, 59	+2.425	+2.575	A23 Motherboard

1500 Power Supply

- If the supply voltages are good on the connector pins indicated:
 - a. Turn power off to the signal generator.
 - b. Remove the A9 Digital Demodulator and measure the resistance of the connection between the appropriate pins of J12/J2, and sockets J12/J2.
 - If the connection is good, replace the A9 Digital Demodulator. (Refer to “[A9 Digital Demodulator \(E4438C Only\)](#)” on page 3-28.)
 - If the connection is bad, replace the A23 Motherboard. (Refer to “[A23 Motherboard](#)” on page 3-56.)
- If the supply voltages are bad on the connector pins indicated:
 - a. Check the origin of the supply.
 - If the supply voltage is good at the origin, replace the A23 Motherboard. (Refer to “[A23 Motherboard](#)” on page 3-56.)
 - If the supply voltage is bad at the origin, troubleshoot the problem using that assembly's troubleshooting procedure.

Self-Tests 16xx for the A7 Baseband Generator (E4438C Only)

Figure 1-22

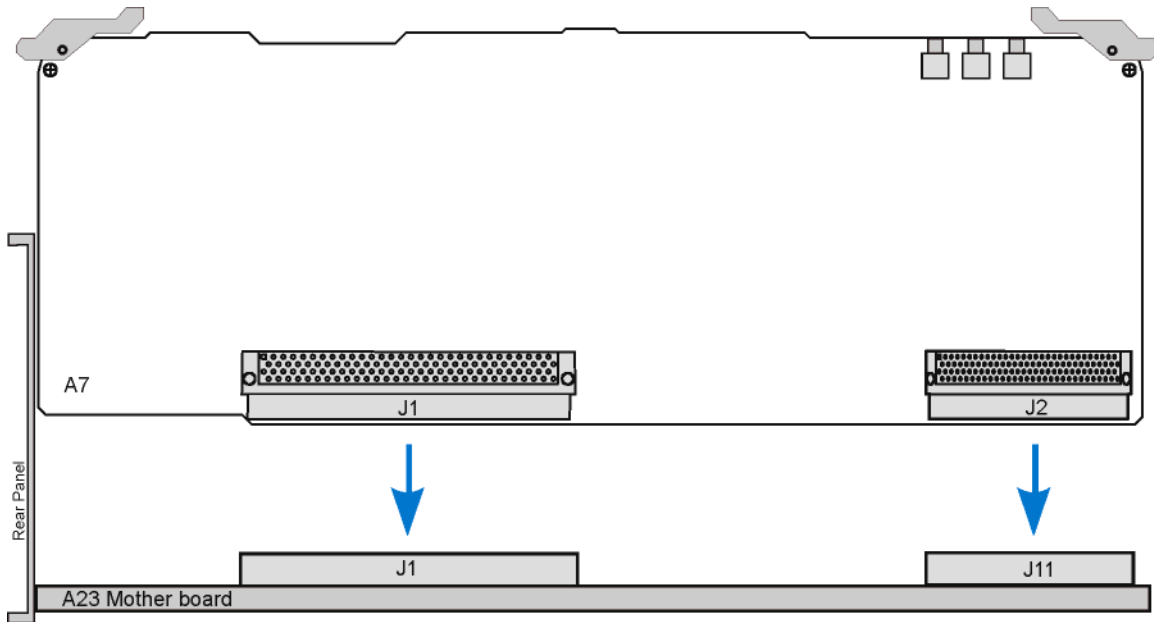

a7_firebld2mthr-bd

Table 1-28

Power Supply Voltage (Vdc)	Connector Pins on the A23 Motherboard	Minimum Value (Vdc)	Maximum Value (Vdc)	Origin
+32	J11-4	+31.04	+32.96	Main Supply
+15	J11-28	+14.1	+15.9	Main Supply
-15	J11-3	-15.9	-14.1	Main Supply
-5.2	J11-1, 26	-5.356	-5.044	Main Supply
+5.2	J11-2, 27	+4.68	+5.72	Main Supply
+3.4 VD	J1-60, 61, 62, 63	+3.298	+3.502	Main Supply
+2.6 VD	J1-57, 58, 59	+2.425	+2.575	A23 Motherboard
+1.9 VD	J1-52	+1.843	+1.957	A23 Motherboard
+1.8 VD	J1-55, 56	+1.746	+1.854	A23 Motherboard

1600 Host <-> BBB Comm

- If the +3.4 VD, +2.6 VD, and +1.9 VD supply voltages are good on the connector pins indicated:
 - a. Turn power off to the signal generator.
 - b. Remove the A7 Baseband Generator and measure the resistance of the connection between the appropriate pins of J1, on the A23 Motherboard side, and socket J1, on the A7 Baseband Generator side.
 - If the connection is good, replace the A7 Baseband Generator. (Refer to “[A7 Baseband Generator \(E4438C Only\)](#)” on page 3-26.)
 - If the connection is bad, replace the A23 Motherboard. (Refer to “[A23 Motherboard](#)” on page 3-56.)
- If the +3.4 VD supply voltage is bad on the connector pins indicated:
 - a. Check the origin of the supply.
 - If the supply voltage is good at the origin, replace the A23 Motherboard. (Refer to “[A23 Motherboard](#)” on page 3-56.)
 - If the supply voltage is bad at the origin, troubleshoot the problem using that assembly's troubleshooting procedure.
- If the +2.6 VD and +1.9 VD supply voltages are bad on the connector pins indicated:
 - a. Replace the A23 Motherboard.

1601 Apps1 <-> Apps2 Comm

- If the +1.8 VD supply voltages is good on the connector pins indicated:
 - a. Turn power off to the signal generator.
 - b. Remove the A7 Baseband Generator and measure the resistance of the connection between the appropriate pins of J1, on the A23 Motherboard side, and socket J1, on the A7 Baseband Generator side.
 - If the connection is good, replace the A7 Baseband Generator. (Refer to “[A7 Baseband Generator \(E4438C Only\)](#)” on page 3-26.)
 - If the connection is bad, replace the A23 Motherboard. (Refer to “[A23 Motherboard](#)” on page 3-56.)
- If the supply voltages are bad on the connector pins indicated:
 - a. Check the origin of the supply.
 - If the supply voltage is good at the origin, replace the A23 Motherboard. (Refer to “[A23 Motherboard](#)” on page 3-56.)
 - If the supply voltage is bad at the origin, troubleshoot the problem using that assembly's troubleshooting procedure.

1602 Apps1 <-> SH4 Comm

- Replace the A7 Baseband Generator.

1603 Apps2 <-> SH4 Comm

- Replace the A7 Baseband Generator.

1604 Fliegen <-> Apps2 Comm

- Replace the A7 Baseband Generator.

1605 SRAM Test

- Replace the A7 Baseband Generator.

1606 SDRAM Test

- Replace the A7 Baseband Generator.

1607 Paren <-> SH4 Comm

- Replace the A7 Baseband Generator.

1608 VCO Tune Test

- If the +32 V, ± 15 V, and ± 5.2 V supply voltages are good on the connector pins indicated:
 - a. Turn power off to the signal generator.
 - b. Remove the A7 Baseband Generator and measure the resistance of the connection between the appropriate pins of J11/J1, on the A23 Motherboard side, and socket J11/J1, on the A7 Baseband Generator side.
 - If the connection is good:
 - a. Re-insert the A7 Baseband Generator.
 - b. Turn power on to the signal generator.
 - c. Check the 10 MHz signal on the A23 Motherboard at J1 pins 26 and 91 using an oscilloscope.

The signal should be 100 ns with an amplitude of approximately 1.0 Vp-p or higher.

- If the 10 MHz signal is good, replace the A7 Baseband Generator. (Refer to “[A7 Baseband Generator \(E4438C Only\)](#)” on page 3-26.)
 - If the 10 MHz signal is bad, troubleshoot the A23 Motherboard and the A7 Baseband Generator.
 - If the connection is bad, replace the A23 Motherboard. (Refer to “[A23 Motherboard](#)” on page 3-56.)
- If the +32 V, ± 15 V, and ± 5.2 V supply voltages are bad on the connector pins indicated:
 - a. Check the origin of the supply.
 - If the supply voltage is good at the origin, replace the A23 Motherboard. (Refer to “[A23 Motherboard](#)” on page 3-56.)
 - If the supply voltage is bad at the origin, troubleshoot the problem using that assembly's troubleshooting procedure.

1609 IQ DAC Output Test

- Replace the A7 Baseband Generator.

1610 PLL Test

- Replace the A7 Baseband Generator.

Self-Tests 20xx for the A14 Extended Frequency Output

Figure 1-23

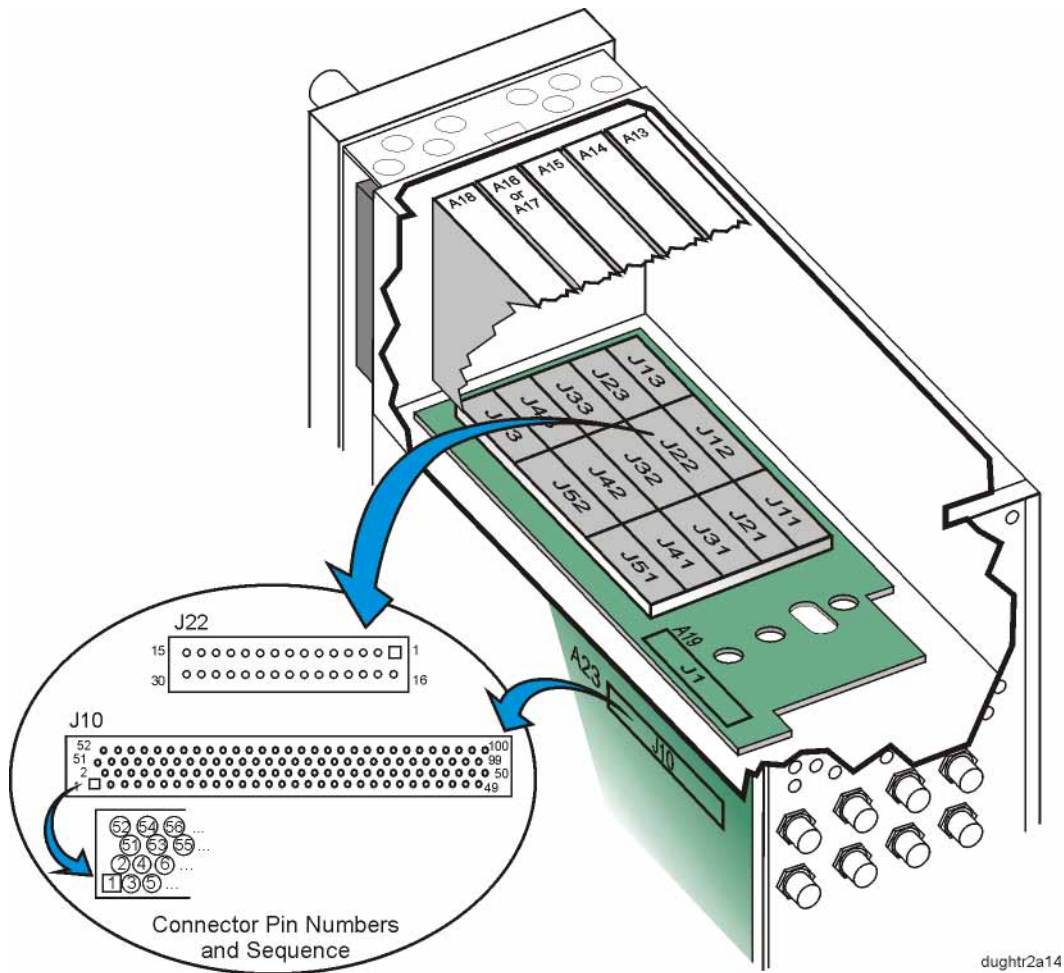

dughtr2a14

Table 1-29

Power Supply Voltage (Vdc)	Connector Pins on the		Minimum Value (Vdc)	Maximum Value (Vdc)	Origin
	A19 Daughterboard	A23 Motherboard			
+15	J22-6, 21	J10-32, 82	+14.1	+15.9	Main Supply
-15	J22-2, 17	J10-36, 86	-15.9	-14.1	Main Supply
+9	J22-5, 20	J10-34, 84	+8.73	+9.27	Main Supply
-6	J22-3, 18	J10-37, 87	-6.36	-5.64	Main Supply
-5.2	J22-4, 19	J10-35, 85	-5.356	-5.044	Main Supply
+5.2	J22-14, 29	J10-30, 31, 80, 81	+4.68	+5.72	Main Supply

2000 Ground and PTAT Test

- Using a DVM, measure the voltages on J10 (the PTAT voltage is derived from the ± 15 Vdc):
 - If the supply voltages are good on the J10 connector pins indicated:
 - a. Turn off the power to the signal generator.
 - b. Remove the A14 Extended Frequency Output.
 - c. Measure the resistance of the connection between the appropriate pins of J22 and J10.
 - If the connection is good, replace the A14 Extended Frequency Output. (Refer to “[A14 Extended Frequency Output](#)” on page 3-38.)
 - If the connection is bad, replace the A19 Daughterboard. (Refer to “[A19 Daughterboard](#)” on page 3-48.)
 - If the supply voltages are bad on any of the J10 connector pins indicated
 - a. Check the origin of the supply.
 - If the supply voltages are good at the origin, replace the A23 Motherboard. (Refer to “[A23 Motherboard](#)” on page 3-56.)
 - If the supply voltages are bad at the origin, troubleshoot the problem using that assembly's troubleshooting procedure.

2001 Prelevel Loop Test

CAUTION Do not install the A14 Extended Frequency Output with the signal generator powered up or serious damage to the signal generator may be caused.

- This test checks the Prelevel loop at three frequencies: 4.1 GHz, 5 GHz, and 6 GHz.
 - If the test fails:
 - a. Press the **View Test Info** softkey and use the RPG to highlight this test.
 - b. Press the **View Details** softkey to display the failed test frequency.
 - c. With the signal generator powered on, carefully remove the A14 Extended Frequency Output.
 - d. Set the signal generator to the failed test frequency (either 4.1 GHz, 5 GHz, or 6 GHz).
 - e. Connect a spectrum analyzer to J4 of the A14 Extended Frequency Output; this is the output signal of the A16 Frac-N.
 - f. The signal at J4 should be at the failed test frequency with an amplitude ≥ -5 dBm.
 - If the signal is not present or at the correct level, refer to troubleshooting for the A16 Frac-N.
 - If the signal is present, replace the A14 Extended Frequency Output. (Refer to “[A14 Extended Frequency Output](#)” on page 3-38.)

2002 Quadrature DAC Test

- Replace the A14 Extended Frequency Output.

2003 VBLO Test

- Replace the A14 Extended Frequency Output.

2004 Marble Test

- Measure the Q signal from the A10 I/Q Multiplexer.
 - a. Disconnect the cable at J9 of the A19 Daughterboard and connect it to a DVM.
 - b. Set the CW frequency to 6 GHz.
 - c. Press: **I/Q > I/Q On > I/Q Adjustments > I/Q Adjustments On > Q Offset**
 - d. Rotate the RPG and observe the DVM.

The voltage should vary from approximately +0.30 Vdc for an offset of 50% to approximately -0.20 Vdc for an offset of 50%.

- If the signal is bad, check the signal at J6 of the A10 I/Q Multiplexer.
 - If the signal is bad at J6, refer to troubleshooting the A10 I/Q Multiplexer.
 - If the signal is good at J6, change the cable.

- Measure the I signal from the A10 I/Q Multiplexer.
 - a. Disconnect the cable at J8 of the A19 Daughterboard and connect it to a DVM.
 - b. Set the CW frequency to 6 GHz.
 - c. Press: **I/Q > I/Q On > I/Q Adjustments > I/Q Adjustments On > I Offset**
 - d. Rotate the RPG and observe the DVM.

The voltage should vary from approximately +0.25 Vdc for an offset of 50% to approximately -0.25 Vdc for an offset of 50%.

- If the signal is bad, check the signal at J5 of the A10 I/Q Multiplexer.
 - If the signal is bad at J5, refer to troubleshooting the A10 I/Q Multiplexer.
 - If the signal is good at J5, change the cable.

- If both the I and Q signals are good, replace the A14 Extended Frequency Output. (Refer to [“A14 Extended Frequency Output” on page 3-38.](#))

2005 Gain Adjustment Test

- Replace the A14 Extended Frequency Output.

2006 ALC Reference Test

- Replace the A14 Extended Frequency Output.

2007 ALC Modulation Test

- Replace the A14 Extended Frequency Output.

2008 Burst Modulation Test

- Replace the A14 Extended Frequency Output.

2009 ALC Detector Test

- Replace the A14 Extended Frequency Output.

2010 Bulk R DAC Test

- Replace the A14 Extended Frequency Output.

2011 Log Offset Test

- Replace the A14 Extended Frequency Output.

Self-Tests 21xx for the A23 Motherboard

Figure 1-24

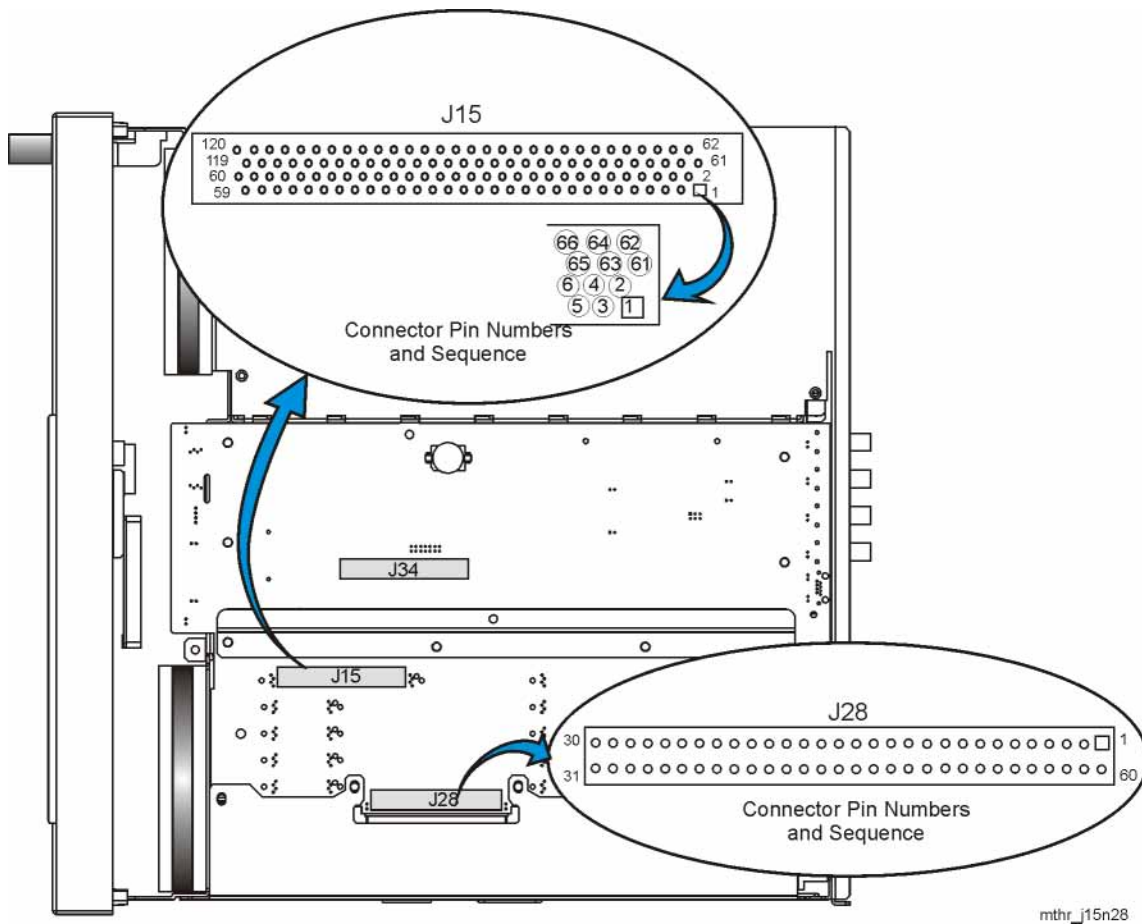

mthr_j15n28

Table 1-30

Power Supply Voltage (Vdc)	Connector Pins on the A23 Motherboard	Minimum Value (Vdc)	Maximum Value (Vdc)	Origin
+32	J28-27	+31.04	+32.96	Main Supply
+15	J28-25, 26	+14.55	+15.45	Main Supply

Table 1-30

-15	J28-23	-15.45	-14.55	Main Supply
+9	J28-19, 42	+8.73	+9.27	Main Supply
-6	J28-38	-6.18	-5.82	Main Supply
-5.2	J28-21, 40	-5.356	-5.044	Main Supply
+5.2 VD	J28-14, 15, 46, 47	+5.044	+5.356	Main Supply
+3.4 VD	J28-1, 2, 5, 6, 9, 10, 51, 52, 55, 56, 59, 60	+3.298	+3.502	Main Supply

2100 Power Supply

- If the supply voltages are good on the connector pins indicated, replace the A23 Motherboard. (Refer to [“A23 Motherboard” on page 3-56.](#))
- If the supply voltages are bad on the connector pins indicated:
 - a. Check the origin of the supply.
 - If the supply voltage is good at the origin, replace the A23 Motherboard. (Refer to [“A23 Motherboard” on page 3-56.](#))
 - If the supply voltage is bad at the origin, troubleshoot the problem using that assembly's troubleshooting procedure.

2101 Sweep Diag

- Replace the A23 Motherboard.

2102 LCD Bias

- Use a DVM to probe A23J15-35 for a signal of approximately 21 Vdc.
 - If the voltage is good, replace the A23 Motherboard. (Refer to [“A23 Motherboard” on page 3-56.](#))
 - If the voltage is bad, troubleshoot the A12 CPU.

Self-Tests 23xx for the A13 Output

Figure 1-25

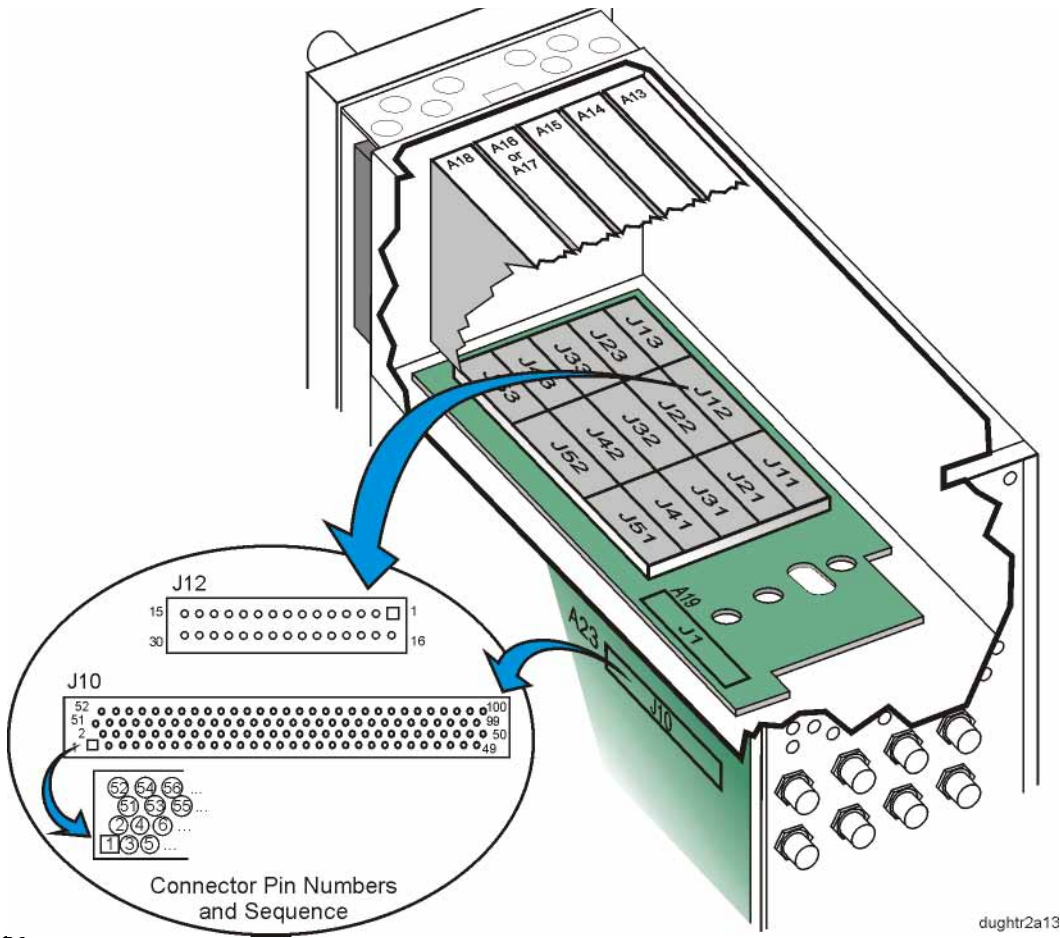

Table 1-31

Power Supply Voltage (Vdc)	Connector Pins on the		Minimum Value (Vdc)	Maximum Value (Vdc)	Origin
	A19 Daughterboard	A23 Motherboard			
+15	J12-6, 21	J10-32, 82	+14.1	+15.9	Main Supply
-15	J12-2, 17	J10-36, 86	-15.9	-14.1	Main Supply
+5.2	J12-14, 29	J10-30, 31, 80, 81	+4.68	+5.72	Main Supply
+9	J12-5, 20	J10-34, 84	+8.73	+9.27	Main Supply
-6	J12-3, 18	J10-37, 87	-6.36	-5.64	Main Supply
-5.2	J12-4, 19	J10-35, 85	-5.356	-5.044	Main Supply

2300 Ground and PTAT Test

- Using a DVM, measure the voltages on J10 (the PTAT voltage is derived from the ± 15 Vdc):
 - If the supply voltages are good on the J10 connector pins indicated:
 - a. Turn off the power and remove the A13 Output.
 - b. Measure the resistance of the connection between the appropriate pins of J12 and J10.
 - If the connection is good, replace the A13 Output. (Refer to “A13 Output” on page 3-36).
 - If the connection is bad, replace the A19 Daughterboard. (Refer to “A19 Daughterboard” on page 3-48).
 - If the supply voltages are bad on any of the J10 connector pins indicated:
 - a. Check the origin of the supply.
 - If the supply voltages are good at the origin, replace the A23 Motherboard. (Refer to “A23 Motherboard” on page 3-56.)
 - If the supply voltages are bad at the origin, troubleshoot the problem using that assembly's troubleshooting procedure.

2301 Prelevel Loop Test

- Replace the A13 Output.

2302 Quadrature Loop Test

- Replace the A13 Output.

2303 Detector Heater Test

- Replace the A13 Output.

2304 IQ Path Test

- Measure the Q signal from the A10 I/Q Multiplexer.
 - a. Disconnect the cable from J3 of the A19 Daughterboard and connect it to a DVM.
 - b. Set the CW frequency to 2 GHz.
 - c. Turn on the I/Q modulation and adjust the Q offset.
 - d. Press: **I/Q > I/Q On > I/Q Adjustments > I/Q Adjustments On > Q Offset**
 - e. Rotate the RPG and observe the DVM. The voltage should vary from approximately +0.25 Vdc for an offset of 50% to approximately -0.25 Vdc for an offset of -50%.
 - If the signal is bad, check it at J10 of the A10 I/Q Multiplexer.
 - If the signal is bad at J10, refer to A10 I/Q Multiplexer troubleshooting.
 - If the signal is good at J10, change the cable.
- Measure the I signal from the A10 I/Q Multiplexer.
 - a. Disconnect the cable from J2 of the A19 Daughterboard and connect it to a DVM.
 - b. Set the CW frequency to 2 GHz.

Troubleshooting Assembly Level Problems

- c. Turn on the I/Q modulation and adjust the I offset.
- d. Press: **I/Q > I/Q On > I/Q Adjustments > I/Q Adjustments On > I Offset**
- e. Rotate the RPG and observe the DVM. The voltage should vary from approximately +0.25 Vdc for an offset of 50% to approximately -0.25 Vdc for an offset of -50%.
 - If the signal is bad, check it at J9 of the A10 I/Q Multiplexer.
 - If the signal is bad at J9, refer to A10 I/Q Multiplexer troubleshooting ([page 1-28](#)).
 - If the signal is good at J9, change the cable.
- If the I and Q signals are good, replace the A13 Output. (Refer to [“A13 Output” on page 3-36](#).)

2305 Prelevel Bypass Test

- Replace the A13 Output.

2306 Switched Filters Test

- Replace the A13 Output.

2307 Gain Adjust Test

- Replace the A13 Output.

2308 ALC Modulation Test

- Replace the A13 Output.

2309 Burst Modulation Test

- Replace the A13 Output.

2310 ALC Detector Test

- Replace the A13 Output.

2311 ALC Closed Loop Test

- Replace the A13 Output.

2312 Detector Logger Test

- Replace the A13 Output.

2313 Het Band Test

- Measure the 1 GHz signal from the A18 Reference.
 - a. With the power off, remove the A13 Output and insert a ribbon cable extender into J11 of the A19 Daughterboard.
 - b. Power on the signal generator and tune to a CW frequency of 200 MHz.
 - c. Using a spectrum analyzer, probe pin 19 of the ribbon cable extender¹ for a 1 GHz signal with an amplitude > -20 dBm:
 - If the signal is present, replace the A13 Output. (Refer to [“A13 Output” on page 3-36](#).)

- If the signal is not present, power down the signal generator and remove the A18 Reference. (Refer to “[A18 Reference](#)” on page 3-46.)
- d. Using a DVM, measure the resistance between J11-19 and J51-19:
 - If the path is open, replace the A19 Daughterboard. (Refer to “[A19 Daughterboard](#)” on page 3-48.)
 - If the path is good (zero ohms), refer to the A18 Reference troubleshooting for the 1 GHz VCO.

-
1. The ribbon cable extender needs to be assembled by the user. It consists of two connector plugs (part number 1252-1010) and approximately eight inches of ribbon cable (part number 8120-2226). The ribbon cable contains 26 wires; six of these wires need to be stripped off before being connected to the plugs.

Troubleshooting Unlocks

The phase lock loop refers to that part of the frequency generating circuit used to maintain the phase relationship between the frequency generation loop and a reference frequency. By maintaining the phase relationship, the frequency accuracy of the signal generator is guaranteed.

To maintain accuracy, the phase lock loop compares the phase of a signal from the reference assembly to the phase of the frequency loop signal. If the two signals are slightly out of phase, the phase comparator circuit adjusts the frequency loop signal until the signals are in phase. If the phase comparator circuit cannot adjust the phase of the frequency loop signal to agree with the reference signal, the phase comparator rails and generates an unlocked message. The unlock message is immediately displayed on the front panel display.

Troubleshoot multiple Loop unlock messages in the following order:

1. [“514 Reference Oven Cold” on page 1-68](#)
2. [“515 10 MHz Signal Bad” on page 1-68](#)
3. [“512 Reference Unlocked” on page 1-69](#)
4. [“513 1 GHz Out of Lock” on page 1-69](#)
5. [“508 Frac-N Loop Unlock \(Option 501, 502, 503, 504\)” on page 1-69](#)
or [“508 Frac-N Loop Unlock \(Option UNJ and Option 506\)” on page 1-69](#)
6. [“520 Sampler Unlocked \(Option UNJ and Option 506\)” on page 1-69](#)
7. [“521 YO Loop Unlocked \(Option UNJ and Option 506\)” on page 1-71](#)
8. [“516 Baseband Generator Unlock \(E4438C Only\)” on page 1-71](#)
9. [“623 Demod Unlock \(E4438C Only\)” on page 1-72](#)

514 Reference Oven Cold

A 514 Reference Oven Cold message indicates that the reference has not been connected to electrical power for 5 minutes. This message appears when the signal generator is unplugged or the A18 Reference is removed. The message is controlled by a timer and should turn off after 5 minutes. This is not a failure unless the message does not go off after 5 minutes.

- o Check that the message goes away after 5 minutes.
 - If the message continues to be displayed after 5 minutes, replace the A18 Reference. (Refer to [“A18 Reference” on page 3-46.](#))

515 10 MHz Signal Bad

A 515 10 MHz Signal Bad message indicates a problem with the output of the 10 MHz reference oscillator on the A18 Reference.

- o Check the display for this unlock message.
 - If the message is present, replace the A18 Reference. (Refer to [“A18 Reference” on page 3-46.](#))

512 Reference Unlocked

A 512 Reference Unlocked message indicates a problem with the 10 MHz reference phase-lock loop on the A18 Reference.

- o Check for and disconnect any external reference signals that are connected to the instrument.
 - If the unlock message goes away when the external reference signal has been disconnected, check that the external reference signal meets the specifications for an external reference.
 - If the unlock message is present with the external reference disconnected, replace the A18 Reference. (Refer to [“A18 Reference”](#) on page 3-46.)

513 1 GHz Out of Lock

A 513 1GHz Out of Lock message indicates a problem with the 1 GHz phase-lock loop on the A18 Reference.

- o Check for and disconnect any external reference signals that are connected to the instrument.
 - If the unlock message goes away when the external reference signal has been disconnected, check that the external reference signal meets the specifications for an external reference.
 - If the unlock message is present with the external reference disconnected, replace the A18 Reference. (Refer to [“A18 Reference”](#) on page 3-46.)

508 Frac-N Loop Unlock (Option 501, 502, 503, 504)

A 508 Frac-N Loop Unlock message indicates a problem with the Voltage Control Oscillator's (VCO) phase-lock loop on the A17 Synthesizer.

- o Check the 10 MHz signal on the A23 Motherboard at J10 pin 99 using an oscilloscope.

The signal should have a period of 100 ns and an amplitude of greater than 1.2 V_{p-p}.

 - If the signal is good, replace the A17 Synthesizer. (Refer to [“A17 Synthesizer”](#) on page 3-44.)
 - If the signal is bad, troubleshoot the A18 Reference. (Refer to [“Self-Tests 8xx for the A18 Reference”](#) on page 1-48.)

508 Frac-N Loop Unlock (Option UNJ and Option 506)

A 508 Frac-N Loop Unlock message indicates a problem with the Voltage Control Oscillator's (VCO) phase-lock loop on the A16 Frac-N.

- o Check the 10 MHz signal on the A23 Motherboard at J10 pin 99 using an oscilloscope.

The signal should have a period of 100 ns and an amplitude of greater than 1.2 V_{p-p}.

 - If the signal is good, replace the A16 Frac-N. (Refer to [“A16 Frac-N”](#) on page 3-42.)
 - If the signal is bad, troubleshoot the A18 Reference. (Refer to [“Self-Tests 8xx for the A18 Reference”](#) on page 1-48.)

520 Sampler Unlocked (Option UNJ and Option 506)

A 520 Sampler Unlocked message indicates a problem with the Voltage Control Oscillator's (VCO) phase-lock loop on the A15 Sampler.

- o Run self-tests.

- If self-tests fail, troubleshoot the problem reported.
- If self-tests pass:
 1. Turn power on to the signal generator.
 2. Remove the A15 Sampler.
 3. Connect a signal analyzer to the A15 Sampler J1 input (W44 cable that comes from the A18 Reference).
 4. Check for the presence of a 1 GHz signal with a power level of 0 dBm or greater.
 - If the signal is good on W44 cable connector for J1, replace the A15 Sampler. (Refer to [“A15 Sampler” on page 3-40.](#))
 - If the signal is bad on the W44 cable connector for J1:
 - a. Turn power off to the signal generator.
 - b. Remove the A18 Reference. (Refer to [“A18 Reference” on page 3-46.](#))
 - c. Ohm the cable between the center pins (a short should be measured) and between the center pin and shielding (an open should be measured) at J3 of the A18 Reference and J1 of the A15 Sampler.
 - If the cable is good, troubleshoot the A18 Reference. (Refer to [“Self-Tests 8xx for the A18 Reference” on page 1-48.](#))
 - If an open is measured between the center pins or a short between the center pins and the shielding, replace the W44 cable.

521 YO Loop Unlocked (Option UNJ and Option 506)

A 521 YO Loop Unlocked message indicates a problem with the YO phase detector on the A15 Sampler.

1. Turn power on to the signal generator.
2. Remove the A15 Sampler.
3. Set the signal generator to 525 MHz.
4. Using a signal analyzer, check for the presence of signals as shown in [Table 1-32](#):
 - If all signals are good, replace the A15 Sampler. (Refer to “[A15 Sampler](#)” on page 3-40.)
 - If any signal is bad, troubleshoot one of the following two assemblies:
 - either the A21 YTO Driver (Refer to “[Self-Tests 6xx for the A21 YTO Driver](#)” on page 1-40.)
 - or the A16 Frac-N (Refer to “[Self-Tests 7xx for the A16 Frac-N](#)” on page 1-43.)

Table 1-32

Signal Generator Output (MHz)	Output of A21 YTO Driver Sampler End of W37	Output of A15 Sampler Sampler End of W11
Tune	A15J3 (> -20 dBm, ±10 MHz)	A15J6 (> +5 dBm, ±10 MHz)
525	4200	796.875
750	6000	644.53
500	8000	593.75

516 Baseband Generator Unlock (E4438C Only)

A 516 Baseband Generator Unlock message indicates a problem with the Voltage Control Oscillator's (VCO) phase-lock loop on the A7 Baseband Generator.

- o Check the 10 MHz signal on the A23 Motherboard at J1 pins 26 and 91 using an oscilloscope.

The signal period should be 100 ns with an amplitude of approximately 1.0 Vp-p or greater.

- If the 10MHz signal is good, replace the A7 Baseband Generator. (Refer to “[A7 Baseband Generator \(E4438C Only\)](#)” on page 3-26.)
- If the signal is not present, troubleshoot one of the following two assemblies:
 - either the A23 Motherboard (Refer to “[Self-Tests 21xx for the A23 Motherboard](#)” on page 1-62.)
 - or the A18 Reference (Refer to “[Self-Tests 8xx for the A18 Reference](#)” on page 1-48.)

623 Demod Unlock (E4438C Only)

A 623 Demod Unlock message indicates a problem with the Voltage Control Oscillator's (VCO) phase-lock loop on the A9 Digital Demodulator.

- o Check the 10 MHz signal on the A23 Motherboard at J2 pins 26 and 91 using an oscilloscope.

The signal period should be 100 ns with an amplitude of approximately 1.0 V_{p-p} or greater.

- If the signal is good, replace the A9 Digital Demodulator. (Refer to “[A9 Digital Demodulator \(E4438C Only\)](#)” on [page 3-28](#).)
- If the signal is bad, troubleshoot one of the following two assemblies:
 - either the A23 Motherboard (Refer to “[Self-Tests 21xx for the A23 Motherboard](#)” on [page 1-62](#).)
 - or the A18 Reference (Refer to “[Self-Tests 8xx for the A18 Reference](#)” on [page 1-48](#).)

Troubleshooting Unlevels and the RF Path

Depending on the signal generator’s frequency range and option selection, there are either one or two output boards used in the RF path:

- Signal generators with Option 501, 502, 503, 504, and Option UNJ contain either the:
 - A13 Output (Option 501, 502, 503, 504 or Option UNJ)
 - or the A13 Output (Option UNB)
- Signal generators with Option 506 contain both the:
 - A13 Output (Option UNB)
 - and the A14 Extended Frequency Output (Option 506)

On the output boards, a leveled output power is obtained by comparing a detected voltage with a reference voltage. The reference voltage is generated using DACs on the output boards. The detected voltage is generated by coupling off a portion of the RF output signal and converting it to dc using detector diodes. When the reference and detected levels are the same, the integrated output level remains constant. When the reference and detected levels are not the same, the integrator output ramps either up or down to increase or decrease the detected level. If the integrator can not achieve a match between the detected voltage and the reference voltage, an unlevelled annunciator is displayed.

Each output board has an Automatic Leveling Control (ALC) circuit which consists of a detector and two modulator diodes. The A13 Output controls the power level for frequencies 4 GHz and below and the A14 Extended Frequency Output (Option 506) controls the power level for frequencies above 4 GHz and ≤ 6 GHz.

The RF path must provide a minimum power level to the ALC loop in order for the ALC loop to work properly and this minimum required power is slightly higher than the maximum-leveled power.

Troubleshooting a Leveling Problem

NOTE Before proceeding to troubleshoot with this section, run a full self-test and correct any reported failures and unlock problems. (Refer to [“Self-Test Failures and Related Troubleshooting”](#) on page 1-17 and [“Troubleshooting Unlocks”](#) on page 1-68.)

- o Check the RF path power level against the values in [Table 1-33](#).

Table 1-33

Frequencies	Standard Power	Option UNB
250 kHz to 1 GHz	+13 dBm	+17 dBm
> 1 GHz to 3 GHz	+10 dBm	+16 dBm
> 3 GHz to 4 GHz	+7 dBm	+13 dBm
> 4 GHz to 6 GHz (Option 506)	N/A	+10 dBm

- If the instrument cannot achieve the maximum power levels listed in [Table 1-33](#), perform the ALC Calibration and the Power Level Accuracy, High Power Calibration.
 - If these adjustments fail or the instrument still cannot achieve the maximum power levels listed in [Table 1-33](#), proceed to [“Troubleshooting the RF Path”](#) on page 1-75.

Troubleshooting Unlevels and the RF Path

- o Check for an Unleveled Annunciator
 - If the Unleveled Annunciator is on:
 1. Check that the signal generator's amplitude is not set higher than the maximum level specified on the *Specifications* data sheet.
 - If the unleveled indication turns off after resetting the amplitude, the signal generator is operating correctly.
 2. Check that the signal generator's RF output is terminated into 50 ohms.
 - If the unleveled indication turns off after terminating the RF output into 50 ohms, the signal generator is operating correctly.
 - If the Unleveled Annunciator remains on:
 1. Use a spectrum analyzer to check the RF signal level at the RF Output connector.
 - *Signal Generator Setup*
 - a. Set **ALC On/Off** to Off
 - b. Set **Amplitude** to +25 dBm
 - c. Set **Modulation** to Off
 - d. Set **RF On/Off** to On
 - e. Set **Sweep** to Frequency
 - f. Set **Sweep Type** to Step
 - g. Set **Start Frequency** to 250 kHz
 - h. Set **Stop Frequency** to 1 GHz
 - i. Set **Number of Points** to 500
 - *Spectrum Analyzer Setup*
 - a. Set **Start Frequency** to 225 kHz
 - b. Set **Stop Frequency** to 1.25 GHz
 - c. Set **Reference Level** to +30 dBm
 - d. Set **Display** to Max Hold
 2. Connect the RF output of the signal generator to the spectrum analyzer.
 3. Measure and record the minimum power level.
 4. Set the signal generator and spectrum analyzer start/stop frequencies to the next start/stop frequencies in [Table 1-34](#).

Table 1-34

Signal Generator		Spectrum Analyzer	
Start	Stop	Start	Stop
1 GHz	3 GHz	999 MHz	3.1 GHz
3 GHz	4 GHz	2.99 GHz	4.1 GHz
4.000000001 GHz	6 GHz	4 GHz	6.1 GHz

5. Measure and record the minimum power level at each start/stop frequency.
 - If any of the frequency ranges do not produce power levels equal to the maximum leveled power shown in [Table 1-33](#), set the signal generator to the frequency with the lowest power level and measure the power with a power meter.
 - If the power level is low, troubleshoot the RF path before proceeding.
 - If the RF signal levels are good, turn ALC On and set the signal generator to maximum-leveled power.

Note the frequencies where the unlevelled condition occur. Later, when troubleshooting in ALC Off mode, the unlevelled indication is turned off.

For each of the unlevelled conditions listed, always start with the signal generator set to the following settings.

- a. Set **ALC Mode** to ALC Off
- b. Set **Amplitude** to +25 dBm
- c. Set **Attenuator Hold Mode** to On
- d. Set **RF On/Off** to On
- e. Set **Modulation** to Off

Troubleshooting the RF Path

Depending on the frequency range that an unlevel is occurring, refer to one of the following:

- Unlevelled or Low Power for Frequencies ≥ 250 kHz and < 250 MHz on [page 1-75](#).
- Unlevelled or Low Power for Frequencies ≥ 250 MHz and ≤ 4 GHz on [page 1-76](#).
- Unlevelled or Low Power for Frequencies > 4 GHz and ≤ 6 GHz (Option 506 Only) on [page 1-77](#).

Unlevelled or Low Power for Frequencies ≥ 250 kHz and < 250 MHz

NOTE Before proceeding to troubleshoot with this section, run a full self-test and correct any reported failures and unlock problems. (Refer to “[Self-Test Failures and Related Troubleshooting](#)” on [page 1-17](#) and “[Troubleshooting Unlocks](#)” on [page 1-68](#).)

1. Set the signal generator to the frequency where the signal generator is unlevelled.
2. With the signal generator powered on, carefully remove the A13 Output.
3. Use a semi-rigid cable extender and connect a spectrum analyzer to the A16 Frac-N or A17 Synthesizer RF output at J4 of the A13 Output and measure the power level.

The amplitude of the signal at J4 should be ≥ 5 dBm and the RF frequency at J4 is determined by the following equation:

$$J4 \text{ Frequency} = 1 \text{ GHz} - \text{Front Panel RF Frequency}$$

- If the J4 signal is good, replace the A13 Output.
- If the J4 signal is bad and the instrument is an:
 - Option 501, 502, 503, 504, replace the A17 Synthesizer.

- Option UNJ or Option 506, check the signal leaving the YIG oscillator.

The YIG frequency is determined by the equation:

$$YIG\ Frequency = (1\ GHz - Front\ Panel\ RF\ Frequency) * 8$$

- If the signal is good out of the YIG, replace the A16 Frac-N.
- If the signal is bad out of the YIG, replace the A21 YTO Driver.
- Option 506, check the signal at the input of the A22 Coupler.
 - If the signal is good, replace the A22 Coupler.
 - If the signal is bad, check the signal leaving the YIG oscillator.

The YIG frequency is determined by the equation:

$$YIG\ Frequency = (1\ GHz - Front\ Panel\ RF\ Frequency) * 8$$

- If the signal is good, replace the semi-rigid cable (W54) between the YIG Oscillator and the input of the A22 Coupler
- If the signal is bad, replace the A21 YTO Driver.

Unleveled or Low Power for Frequencies ≥ 250 MHz and ≤ 4 GHz

NOTE Before proceeding to troubleshoot with this section, run a full self-test and correct any reported failures and unlock problems. (Refer to [“Self-Test Failures and Related Troubleshooting”](#) on page 1-17 and [“Troubleshooting Unlocks”](#) on page 1-68.)

1. Set the signal generator to the unleveled frequency.
2. With the signal generator powered on, carefully remove the A13 Output.
3. Use a semi-rigid cable extender and connect a spectrum analyzer to the A16 Frac-N or A17 Synthesizer RF output at J4 of the A13 Output.

The signal at J4 should be the same frequency that the signal generator is set to and the amplitude at J4 should be ≥ 0 dBm.

- If the J4 signal is good, replace the A13 Output.
- If the J4 signal is bad and the instrument is an:
 - Option 501, 502, 503, 504, change the A17 Synthesizer.
 - Option UNJ, check the signal leaving the YIG Oscillator.

The YIG frequency will be higher than the front panel frequency. It is divided down with the divisor being dependent on the front panel frequency.

- If the signal is good, change the A16 Frac-N.
- If the signal is bad out of the YIG, change the A21 YTO Driver
- Option 506, check the signal at the input of the A22 Coupler.
 - If the signal is good, replace the A22 Coupler.
 - If the signal is bad, check the signal leaving the YIG Oscillator.

The YIG frequency will be higher than the front panel frequency. It is divided down with the divisor being dependent on the front panel frequency.

- If the signal is good, replace the semi-rigid cable (W54) between the YIG Oscillator and the input of the A22 Coupler. (Refer to [“Semi-Rigid Cables - Includes the A21 YTO Driver and the AT1 High-Power Mechanical Attenuator \(Option UNB\) with an A29 DC Blocking Capacitor”](#) on page 2-59.)
- If the signal is bad, change the A21 YTO Driver.

Unleveled or Low Power for Frequencies > 4 GHz and ≤ 6 GHz (Option 506 Only)

NOTE Before proceeding to troubleshoot with this section, run a full self-test and correct any reported failures and unlock problems. (Refer to [“Self-Test Failures and Related Troubleshooting”](#) on page 1-17 and [“Troubleshooting Unlocks”](#) on page 1-68.)

1. Set the signal generator to the unleveled frequency.
2. With the signal generator powered on, carefully remove the A14 Extended Frequency Output.
3. Use a semi-rigid cable extender and connect a spectrum analyzer to the A22 Coupler on the coupled output at J4 of the A14 Extended Frequency Output.

The signal at J4 should be the same frequency that the signal generator is set to and the amplitude at J4 should be ≥ -8 dBm.

- If the J4 signal is good, replace the A14 Extended Frequency Output.
- If the J4 signal is bad, measure the signal at the cable (W54) connected to the input of the A22 Coupler.
 - If the signal is good, change the A22 Coupler.
 - If the signal is bad, check the signal leaving the YIG Oscillator.

The YIG frequency will be the same as the front panel frequency.

- If the signal is good, replace the semi-rigid cable (W54) between the YIG Oscillator and the input of the A22 Coupler. (Refer to [“Semi-Rigid Cables - Includes the A21 YTO Driver and the AT1 High-Power Mechanical Attenuator \(Option UNB\) with an A29 DC Blocking Capacitor”](#) on page 2-59.)
- If the signal is bad, change the A21 YTO Driver.

Troubleshooting the AT1 Electronic Attenuator

The AT1 Electronic Attenuator has an attenuation range of 130 dB in 5 dB steps. This attenuator is used to coarse-tune the power level while the Automatic Leveling Control (ALC) loop is used to fine-tune the power level; the ALC fine-tunes the power level within each 5 dB step.

The attenuator is set to 0 dB attenuation for power levels from 0 dBm to +25 dBm. The first 5 dB step is switched in at approximately -0.5 dBm, the second step is switched in at approximately -5.5 dBm, the third step is switched in at approximately -10.5 dBm; this pattern repeats until the last 5 dB step is switched in at approximately -125.5 dBm. Attenuator control comes from the A23 Motherboard through A23J25.

Table 1-35

Power Supply Voltage (Vdc)	Connector Pins on the A23 Motherboard	Minimum Value (Vdc)	Maximum Value (Vdc)	Origin
+12	J25-14	+12.10	+12.90	A23 Motherboard
-12	J25-13	-12.90	-12.10	A23 Motherboard
+5	J25-15	+4.5	+5.356	Main Supply

- o Check the power supply voltage on A23J25.
 - If the power supply voltage on A23J25 is good:
 1. Set the amplitude to +0 dBm.
 2. Set the amplitude increment to 5 dB.
 3. Set the **RF On/Off** to RF On.
 4. Set the amplitude level using the Down arrow key.
 5. Use [Table 1-38](#) to isolate the problem.
 - If the attenuator control line voltages are correct for the given amplitude setting, check the attenuator ribbon cable (W57):
 - If the attenuator ribbon cable is good, replace the AT1 Electronic Attenuator.
 - If the attenuator ribbon cable is bad, replace W57.
 - If the attenuator control line voltages are wrong for the given amplitude setting, check the that the control voltages change within a 5 dB range (Refer to [Table 1-38](#)):
 - If the attenuator control line voltages change within 5 dB, return the unit back to Agilent Technologies for calibration.
 - If the attenuator control line voltages do not change within 5 dB, replace the A23 Motherboard. (Refer to [“Self-Tests 21xx for the A23 Motherboard”](#) on page 1-62.)
 - If the power supply voltage on A23J25 is bad, troubleshoot the A6 Power Supply. (Refer to [“Power Supplies”](#) on page 1-21.)

NOTE Table 1-36 shows the amplitude levels and the corresponding attenuator control line voltages. The amplitude levels are chosen so that they are approximately in the center of each 5 dB switch point. Due to calibration variations, the absolute range of each 5 dB attenuation step may have to be re-established. This can be accomplished by decreasing the power setting while monitoring A23J25 pin 9. Note the power setting when the control line goes TTL-high (+5 V) and continue decreasing the power and noting the power setting when the control line goes TTL low (0 V). The difference in the two settings is the new range. Once a new range is established, use the mid-point of each new range as the amplitude settings in place of the settings in Table 1-36.

Table 1-36 Attenuator Control Lines and Corresponding Amplitude Levels

A23J25 Pin Numbers and Voltages							
Amplitude Level (dBm)	Pin 4 5 dB Step	Pin 9 5 dB Step	Pin 6 10 dB Step	Pin 7 10 dB Step	Pin 3 20 dB Step	Pin 5 40 dB Step	Pin 10 40 dB Step
+0	0	0	0	0	0	0	0
-5	+5	0	0	0	0	0	0
-10	+5	+5	0	0	0	0	0
-15	+5	0	+5	0	0	0	0
-20	+5	+5	+5	0	0	0	0
-25	+5	0	+5	+5	0	0	0
-30	+5	+5	+5	+5	0	0	0
-35	+5	0	+5	0	+5	0	0
-40	+5	+5	+5	0	+5	0	0
-45	+5	0	+5	+5	+5	0	0
-50	+5	+5	+5	+5	+5	0	0
-55	+5	0	+5	0	0	+5	0
-60	+5	+5	+5	0	0	+5	0
-65	+5	0	+5	+5	0	+5	0
-70	+5	+5	+5	+5	0	+5	0
-75	+5	0	+5	0	+5	+5	0
-80	+5	+5	+5	0	+5	+5	0
-85	+5	0	+5	+5	+5	+5	0
-90	+5	+5	+5	+5	+5	+5	0
-95	+5	0	+5	0	0	+5	+5
-100	+5	+5	+5	0	0	+5	+5

Table 1-36 Attenuator Control Lines and Corresponding Amplitude Levels (Continued)

-105	+5	0	+5	+5	0	+5	+5
-110	+5	+5	+5	+5	0	+5	+5
-115	+5	0	+5	0	+5	+5	+5
-120	+5	+5	+5	0	+5	+5	+5
-125	+5	0	+5	+5	+5	+5	+5
-130	+5	+5	+5	+5	+5	+5	+5

Troubleshooting the AT1 High-Power Mechanical Attenuator

The AT1 High-Power Mechanical Attenuator has an attenuation range of 130 dB in 5 dB steps. This attenuator is used to coarse-tune the power level while the Automatic Leveling Control (ALC) loop is used to fine-tune the power level; the ALC fine-tunes the power level within each 5 dB step.

The attenuator is set to 0 dB attenuation for power levels from 0 dBm to +25 dBm. The first 5 dB step is switched in at approximately –0.5 dBm, the second step is switched in at approximately –5.5 dBm, the third step is switched in at approximately –10.5 dBm; this pattern repeats until the last 5 dB step is switched in at approximately –125.5 dBm. Attenuator control comes from the A23 Motherboard through A23J25.

Table 1-37

Power Supply Voltage (Vdc)	Connector Pins on A23 Motherboard	Minimum Value (Vdc)	Maximum Value (Vdc)	Origin
+15	J25-1	+14.1	+15.9	Main Supply

- o Check the power supply voltage on A23J25 pin 1.
 - If the power supply voltage on A23J25 pin 1 is good:
 1. Set the amplitude to +2 dBm.
 2. Set the amplitude increment to 5 dB.
 3. Set the **RF On/Off** to RF On.
 4. Set the amplitude level using the Down arrow key.
 5. Use [Table 1-38](#) to isolate the problem.
 - If the attenuator control line voltages are correct for the given amplitude setting, check the attenuator ribbon cable (W57):
 - If the attenuator ribbon cable is good, replace the AT1 High-Power Mechanical Attenuator.
 - If the attenuator ribbon cable is bad, replace W57.
 - If the attenuator control line voltages are wrong for the given amplitude setting, check the that the control voltages change within a 5 dB range (Refer to [Table 1-38](#)):
 - If the attenuator control line voltages change within 5 dB, return the unit back to Agilent Technologies for calibration.
 - If the attenuator control line voltages do not change within 5 dB, replace the A23 Motherboard. (Refer to [“Self-Tests 21xx for the A23 Motherboard”](#) on page 1-62.)
 - If the power supply voltage on A23J25 pin 1 is bad, troubleshoot the A6 Power Supply. (Refer to [“Power Supplies”](#) on page 1-21.)

NOTE Table 1-38 shows the amplitude levels and the corresponding attenuator control line voltages. The amplitude levels are chosen so that they are approximately in the center of each 5 dB switch point. Due to calibration variations, the absolute range of each 5 dB attenuation step may have to be re-established. This can be accomplished by decreasing the power setting while monitoring A23J25 pin 10. Note the power setting when the control line goes TTL-high (+5 V) and continue decreasing the power and noting the power setting when the control line goes TTL low (0 V). The difference in the two settings is the new range. Once a new range is established, use the mid-point of each new range as the amplitude settings in place of the settings in Table 1-38.

Table 1-38 Attenuator Control Lines and Corresponding Amplitude Levels

A23J25 Pin Numbers and Voltages					
Amplitude Level (dBm)	Pin 10 5 dB Step	Pin 9 10 dB Step	Pin 6 20 dB Step	Pin 7 40 dB Step	Pin 5 60 dB Step
+2	0	0	0	0	0
-3	+5	0	0	0	0
-8	0	+5	0	0	0
-13	+5	+5	0	0	0
-18	0	0	+5	0	0
-23	+5	0	+5	0	0
-28	0	+5	+5	0	0
-33	+5	+5	+5	0	0
-38	0	0	0	+5	0
-43	+5	0	0	+5	0
-48	0	+5	0	+5	0
-53	+5	+5	0	+5	0
-58	0	0	0	0	+5
-63	+5	0	0	0	+5
-68	0	+5	0	0	+5
-73	+5	+5	0	0	+5
-78	0	0	+5	0	+5
-83	+5	0	+5	0	+5
-88	0	+5	+5	0	+5
-93	+5	+5	+5	0	+5
-98	0	0	0	+5	+5
-103	+5	0	0	+5	+5
-108	0	+5	0	+5	+5

Table 1-38 Attenuator Control Lines and Corresponding Amplitude Levels

-113	+5	+5	0	+5	+5
-118	0	0	+5	+5	+5
-123	+5	0	+5	+5	+5
-128	0	+5	+5	+5	+5

Troubleshooting Adjustment Problems

When an adjustment does not work or fails to resolve a problem and all self-tests have passed, use the following table to locate the most likely failure.

NOTE Agilent Technologies recommends calibrating the E4428C/38C ESG-C Signal Generator every two years.

Table 1-39 Troubleshooting Adjustment Problems

The following adjustments are listed in the order that they should be performed for proper calibration.	
Adjustment that is failing...	Assemblies most likely causing failure...
Analog Bus ADC Calibration	<ul style="list-style-type: none"> A12 CPU Refer to “Troubleshooting Analog Bus ADC Calibration Failures” on page 1-87
Pretune Calibration (Option UNJ or Option 506 Only)	<ul style="list-style-type: none"> A21 YTO Driver A16 Frac-N
Internal Source Calibration	<ul style="list-style-type: none"> A23 Motherboard A18 Reference
VCO Bias Potentiometer Calibration	<ul style="list-style-type: none"> A17 Synthesizer A16 Frac-N
Lock Angle Potentiometer Calibration (Not Used with Option UNJ or Option 506)	<ul style="list-style-type: none"> A17 Synthesizer
KV versus Frequency Calibration	<ul style="list-style-type: none"> A17 Synthesizer A16 Frac-N
Timebase DAC Calibration	<ul style="list-style-type: none"> A18 Reference
FM Scale DAC Offset Calibration	<ul style="list-style-type: none"> A18 Reference
FM Path Offset Calibration	<ul style="list-style-type: none"> A18 Reference
FM In-Band DAC Offset Calibration	<ul style="list-style-type: none"> A16 Frac-N A17 Synthesizer
FM Inverting Amplifier Offset Calibration	<ul style="list-style-type: none"> A16 Frac-N A17 Synthesizer
FM 1/2 Path Ratio Gain Calibration	<ul style="list-style-type: none"> A18 Reference
Modulation Source Relative Gain Calibration	<ul style="list-style-type: none"> A18 Reference A23 Motherboard
FM Out-of-Band Calibration (Not Used with Option UNJ or Option 506)	<ul style="list-style-type: none"> A16 Frac-N A21 YTO Driver
FM/PM YO Frequency Compensation Calibration (Option UNJ or Option 506 Only)	<ul style="list-style-type: none"> A21 YTO Driver
DCFM Calibration	<ul style="list-style-type: none"> A16 Frac-N A17 Synthesizer
Low Frequency (LF) Output Calibration	<ul style="list-style-type: none"> A18 Reference A23 Motherboard
External Input Peak Detector Calibration	<ul style="list-style-type: none"> A18 Reference

Table 1-39 Troubleshooting Adjustment Problems (Continued)

The following adjustments are listed in the order that they should be performed for proper calibration.	
Adjustment that is failing...	Assemblies most likely causing failure...
Burst Modulator Calibration	<ul style="list-style-type: none"> • A13 Output • A14 Extended Frequency Output
Burst Audio Path Gain Calibration	<ul style="list-style-type: none"> • A13 Output • A14 Extended Frequency Output • A18 Reference
AM Audio Path Offset Calibration	<ul style="list-style-type: none"> • A18 Reference
Prelevel Calibration	<ul style="list-style-type: none"> • A13 Output • A14 Extended Frequency Output
VBLO Mixer Bias Calibration	<ul style="list-style-type: none"> • A13 Output • A14 Extended Frequency Output
Digital Gain Adjust Calibration (E4438C Only)	<ul style="list-style-type: none"> • A13 Output • A14 Extended Frequency Output
Bypass Gain Adjust Calibration	<ul style="list-style-type: none"> • A13 Output • A14 Extended Frequency Output
ALC Calibration	<ul style="list-style-type: none"> • A13 Output • A14 Extended Frequency Output
Power Level Accuracy, High Power Calibration	<ul style="list-style-type: none"> • AT1 High-Power Mechanical Attenuator • A28 Reverse Power Protection • A13 Output • A14 Extended Frequency Output • A29 DC Blocking Capacitor
ALC Modulation Driver Bias Calibration	<ul style="list-style-type: none"> • A13 Output • A14 Extended Frequency Output

Table 1-39 Troubleshooting Adjustment Problems (Continued)

The following adjustments are listed in the order that they should be performed for proper calibration.	
Adjustment that is failing...	Assemblies most likely causing failure...
Power Level Accuracy, Low Power Calibration	<ul style="list-style-type: none"> • AT1 High-Power Mechanical Attenuator • A28 Reverse Power Protection • Loose or leaky RF cables
Power Search Calibration	<ul style="list-style-type: none"> • A13 Output • A14 Extended Frequency Output
AM Gain Calibration	<ul style="list-style-type: none"> • A13 Output • A14 Extended Frequency Output
I/Q Gain/Offset/Quadrature Calibration (E4438C Only)	<ul style="list-style-type: none"> • A10 I/Q Multiplexer • A13 Output • A14 Extended Frequency Output • A7 Baseband Generator
I/Q Impairment Calibration (E4438C Only)	<ul style="list-style-type: none"> • A10 I/Q Multiplexer • A13 Output • A14 Extended Frequency Output

Troubleshooting Analog Bus ADC Calibration Failures

The Analog Bus ADC Calibration adjusts the ADC reference voltage to match the A12 CPU +10 Vdc reference.

There are three main reasons that this calibration could fail:

- problems with the +10 Vdc reference
- A12 CPU problems
- an analog multiplexer on another assembly is starting to fail

Depending on the option of your signal generator, perform one of the following:

- [Procedure for Signal Generators with Option 501, 502, 503, 504 on page 1-87](#)
- [Procedure for Signal Generators with Option UNJ on page 1-88](#)
- [Procedure for Signal Generators with Option 506 on page 1-89](#)

Procedure for Signal Generators with Option 501, 502, 503, 504

- Run Self-Test 1100.
 - If Self-Test 1100 passes:
 - a. Turn the power off to the signal generator and remove the A17 Synthesizer and A18 Reference.
 - b. Using service software, run the Analog Bus ADC Calibration.
 - If the calibration passes:
 - a. Turn the power off to the signal generator.
 - b. Re-install the A17 Synthesizer.
 - c. Re-run the Analog Bus ADC Calibration.
 - If the calibration passes, replace the A18 Reference.
 - If the calibration fails, replace the A17 Synthesizer.
 - If the calibration fails:
 - a. Turn the power off to the signal generator.
 - b. Re-install both the A17 Synthesizer and A18 Reference.
 - c. Remove the A13 Output.
 - d. Re-run the Analog Bus ADC Calibration.
 - If the calibration passes, replace the A13 Output.
 - If the calibration fails, replace the A12 CPU.
 - If Self-Test 1100 fails, refer to [“Self-Tests 11xx for the A12 CPU” on page 1-50](#).

Procedure for Signal Generators with Option UNJ

- Run Self-Test 1100.
 - If Self-Test 1100 passes:
 - a. Turn the power off to the signal generator and remove the A15 Sampler, A16 Frac-N, and A18 Reference.
 - b. Using service software, run the Analog Bus ADC Calibration.
 - If the calibration passes:
 - a. Turn the power off to the signal generator.
 - b. Re-install the A15 Sampler.
 - c. Re-run the Analog Bus ADC Calibration.
 - If the calibration passes:
 - a. Re-install the A16 Frac-N.
 - b. Re-run the calibration.
 - If the calibration passes, replace the A18 Reference.
 - If the calibration fails, replace the A16 Frac-N.
 - If the calibration fails, replace the A15 Sampler.
 - If the calibration fails:
 - a. Turn the power off to the signal generator.
 - b. Re-install the A15 Sampler, A16 Frac-N, and A18 Reference.
 - c. Remove the A13 Output.
 - d. Re-run the Analog Bus ADC Calibration.
 - If the calibration passes, replace the A13 Output.
 - If the calibration fails, replace the A12 CPU.
 - If Self-Test 1100 fails, refer to [“Self-Tests 11xx for the A12 CPU” on page 1-50](#).

Procedure for Signal Generators with Option 506

- Run Self-Test 1100.
 - If Self-Test 1100 passes:
 - a. Turn the power off to the signal generator and remove the A15 Sampler, A16 Frac-N, and A18 Reference.
 - b. Using service software, run the Analog Bus ADC Calibration.
 - If the calibration passes:
 - a. Turn the power off to the signal generator.
 - b. Re-install the A15 Sampler.
 - c. Re-run the Analog Bus ADC Calibration.
 - If the calibration passes:
 - a. Re-install the A16 Frac-N.
 - b. Re-run the calibration.
 - If the calibration passes, replace the A18 Reference. (Refer to [“A18 Reference” on page 3-46.](#))
 - If the calibration fails, replace the A16 Frac-N. (Refer to [“A16 Frac-N” on page 3-42.](#))
 - If the calibration fails, replace the A15 Sampler. (Refer to [“A15 Sampler” on page 3-40.](#))
 - If the calibration fails:
 - a. Turn the power off to the signal generator.
 - b. Re-install the A15 Sampler, A16 Frac-N, and A18 Reference.
 - c. Remove the A13 Output and A14 Extended Frequency Output.
 - d. Re-run the Analog Bus ADC Calibration.
 - If the calibration passes:
 - a. Re-install the A13 Output.
 - b. Re-run the calibration.
 - If the calibration passes, replace the A14 Extended Frequency Output. (Refer to [“A14 Extended Frequency Output” on page 3-38.](#))
 - If the calibration fails, replace the A13 Output. (Refer to [“A13 Output” on page 3-36.](#))
 - If the calibration fails, replace the A12 CPU. (Refer to [“A12 CPU” on page 3-34.](#))
 - If Self-Test 1100 fails, refer to [“Self-Tests 11xx for the A12 CPU” on page 1-50.](#)

Troubleshooting Performance Test Problems

Performance test that is failing...	Action to perform...
<p>Internal AM Accuracy</p> <p>This is part of the Internal AM Accuracy and Distortion performance test.</p> <p>Note</p> <p>When a performance test fails and all self-tests have passed, use this table to locate the most likely cause. These performance tests are listed in the order that they should be performed to minimize changes in test equipment configurations.</p>	<ul style="list-style-type: none"> • Perform: <ul style="list-style-type: none"> — Internal Source Calibration — All AM Adjustments • If still failing and: <ul style="list-style-type: none"> — problem is at carrier frequencies ≤ 4 GHz, troubleshoot the following assemblies: <ul style="list-style-type: none"> — A18 Reference — A13 Output — A23 Motherboard — problem is only at carrier frequencies > 4 GHz, troubleshoot the following assemblies: <ul style="list-style-type: none"> — A14 Extended Frequency Output
<p>Internal FM Accuracy</p> <p>This is part of the Internal FM Accuracy and Distortion performance test.</p>	<ul style="list-style-type: none"> • Perform: <ul style="list-style-type: none"> — Internal Source Calibration — KV versus Frequency Calibration — All FM adjustments • If still failing, troubleshoot the following assemblies: <ul style="list-style-type: none"> — A17 Synthesizer or A16 Frac-N — A18 Reference — A23 Motherboard
<p>Internal PM Accuracy</p> <p>This is part of the Phase Modulation Accuracy and Distortion performance test.</p>	<ul style="list-style-type: none"> • Perform: <ul style="list-style-type: none"> — Internal FM Accuracy and Distortion • If still failing, troubleshoot the following assemblies: <ul style="list-style-type: none"> — A17 Synthesizer or A16 Frac-N — A18 Reference

Performance test that is failing...	Action to perform...
<p>Internal AM Distortion</p> <p>This is part of the Internal AM Accuracy and Distortion performance test.</p>	<ul style="list-style-type: none"> • Perform: <ul style="list-style-type: none"> — Internal AM Accuracy (This is part of the Internal AM Accuracy and Distortion performance test.) — All AM Adjustments • If still failing and: <ul style="list-style-type: none"> — problem is at carrier frequencies ≤ 4 GHz, troubleshoot the following assemblies: <ul style="list-style-type: none"> — A18 Reference — A13 Output — A23 Motherboard — problem is only at carrier frequencies > 4 GHz, troubleshoot the following assemblies: <ul style="list-style-type: none"> — A14 Extended Frequency Output
<p>Internal FM Distortion</p> <p>This is part of the Internal FM Accuracy and Distortion performance test.</p>	<ul style="list-style-type: none"> • Perform: <ul style="list-style-type: none"> — Internal FM Accuracy (This is part of the Internal FM Accuracy and Distortion performance test.) • If still failing, troubleshoot the following assemblies: <ul style="list-style-type: none"> — A17 Synthesizer or A16 Frac-N — A18 Reference — A23 Motherboard
<p>Internal PM Distortion</p> <p>This is part of the Phase Modulation Accuracy and Distortion performance test.</p>	<ul style="list-style-type: none"> • Perform: <ul style="list-style-type: none"> — Internal PM Accuracy (This is part of the Phase Modulation Accuracy and Distortion performance test.) • If still failing, troubleshoot the following assemblies: <ul style="list-style-type: none"> — A17 Synthesizer or A16 Frac-N — A18 Reference

Troubleshooting Performance Test Problems

Performance test that is failing...	Action to perform...
AM Frequency Response	<ul style="list-style-type: none"> • Perform: <ul style="list-style-type: none"> — Internal AM Accuracy (This is part of the Internal AM Accuracy and Distortion performance test.) • If still failing and: <ul style="list-style-type: none"> — problem is at carrier frequencies ≤ 4 GHz, troubleshoot the following assemblies: <ul style="list-style-type: none"> — A13 Output — problem is only at carrier frequencies > 4 GHz, troubleshoot the following assemblies: <ul style="list-style-type: none"> — A14 Extended Frequency Output
FM Frequency Response	<ul style="list-style-type: none"> • Perform: <ul style="list-style-type: none"> — Internal FM Accuracy (This is part of the Internal FM Accuracy and Distortion performance test.) • If still failing, troubleshoot the following assemblies: <ul style="list-style-type: none"> — A17 Synthesizer or A16 Frac-N
Phase Modulation Frequency Response	<ul style="list-style-type: none"> • Perform: <ul style="list-style-type: none"> — Internal PM Accuracy (This is part of the Phase Modulation Accuracy and Distortion performance test.) • If still failing, troubleshoot the following assemblies: <ul style="list-style-type: none"> — A17 Synthesizer or A16 Frac-N
DCFM Frequency Offset Relative to CW	<ul style="list-style-type: none"> • Perform: <ul style="list-style-type: none"> — DCFM Calibration • If still failing, troubleshoot the following assemblies: <ul style="list-style-type: none"> — A18 Reference — A23 Motherboard
Residual FM (Not Used with Option UNJ or Option 506)	<ul style="list-style-type: none"> • Perform: <ul style="list-style-type: none"> — No adjustments. • If failing, troubleshoot the following assemblies: <ul style="list-style-type: none"> — A18 Reference — A17 Synthesizer

Performance test that is failing...	Action to perform...
Phase Noise and Residual FM (Manual Test - Option UNJ or Option 506 Only)	<ul style="list-style-type: none"> • Perform: <ul style="list-style-type: none"> — No adjustments. • If failing, refer to: <ul style="list-style-type: none"> — “Troubleshooting Phase Noise (Option UNJ and Option 506 Only)” on page 1-102
Harmonics Part of the Harmonic, Subharmonic, and Nonharmonic Spurious Signals performance test.	<ul style="list-style-type: none"> • Perform: <ul style="list-style-type: none"> — No adjustments. • If failing, refer to: <ul style="list-style-type: none"> — “Troubleshooting Harmonic Spurious” on page 1-97
Subharmonics Part of the Harmonic, Subharmonic, and Nonharmonic Spurious Signals performance test.	<ul style="list-style-type: none"> • Perform: <ul style="list-style-type: none"> — No adjustments. • If failing, troubleshoot the following assemblies: <ul style="list-style-type: none"> — A17 Synthesizer
Nonharmonics Part of the Harmonic, Subharmonic, and Nonharmonic Spurious Signals performance test.	<ul style="list-style-type: none"> • Perform: <ul style="list-style-type: none"> — No adjustments. • If failing, refer to: <ul style="list-style-type: none"> — “Troubleshooting Non-Harmonic Spurious” on page 1-100
Power Level Accuracy	<p>If the problem shows up at high power levels ≥ -55 dBm:</p> <ul style="list-style-type: none"> • Perform: <ul style="list-style-type: none"> — Digital Gain Adjust Calibration — Bypass Gain Adjust Calibration — ALC Modulation Driver Bias Calibration — ALC Calibration — Power Level Accuracy, High Power Calibration • If still failing, at high power levels ≥ -55 dBm, refer to: <ul style="list-style-type: none"> — “Troubleshooting Unlevels and the RF Path” on page 1-73 <p>If the problem shows up only at low power levels < -55 dBm:</p> <ul style="list-style-type: none"> • Perform: <ul style="list-style-type: none"> — Power Level Accuracy, Low Power Calibration — Check the AT1 step attenuator and all semi-rigid cabling in the RF path.

Troubleshooting Performance Test Problems

Performance test that is failing...	Action to perform...
Timebase Aging Rate (Manual Test - Option UNJ, Option 506, or Option 1E5 Only)	<ul style="list-style-type: none"> • Perform: <ul style="list-style-type: none"> — Timebase DAC Calibration • If failing, troubleshoot the following assemblies: <ul style="list-style-type: none"> — A18 Reference
Digital Modulation Level Accuracy (E4438C Only)	<ul style="list-style-type: none"> • Perform: <ul style="list-style-type: none"> — All I/Q calibrations • If failing, troubleshoot the following assemblies: <ul style="list-style-type: none"> — A13 Output (fails only ≤ 4 GHz) — A14 Extended Frequency Output (fails only > 4 GHz)
Internal Digital Modulation Quality (Option 402 Only — E4438C Only)	<ul style="list-style-type: none"> • Perform: <ul style="list-style-type: none"> — All I/Q calibrations — I/Q Modulation Quality (Option 402 Only) • If still failing, troubleshoot the failure. • If it passes, troubleshoot the following assemblies: <ul style="list-style-type: none"> — A10 I/Q Multiplexer — A13 Output (fails only ≤ 4 GHz) — A14 Extended Frequency Output (fails only > 4 GHz)
Custom I/Q RF Modulation Quality (Option 402 Only — E4438C Only)	<ul style="list-style-type: none"> • Perform: <ul style="list-style-type: none"> — All I/Q calibrations — I/Q Modulation Quality (Option 402 Only) • If still failing, troubleshoot the failure. • If it passes, troubleshoot the following assemblies: <ul style="list-style-type: none"> — A10 I/Q Multiplexer — A13 Output (fails only ≤ 4 GHz) — A14 Extended Frequency Output (fails only > 4 GHz)
I/Q Modulation Quality (Option 402 Only — E4438C Only)	<ul style="list-style-type: none"> • Perform: <ul style="list-style-type: none"> — All I/Q calibrations • If still failing, troubleshoot the following assemblies: <ul style="list-style-type: none"> — A7 Baseband Generator — A10 I/Q Multiplexer

Performance test that is failing...	Action to perform...
Pulse Modulation On/Off Ratio	<ul style="list-style-type: none"> • Perform: <ul style="list-style-type: none"> — No adjustments • If failing, troubleshoot the following assemblies: <ul style="list-style-type: none"> — A18 Reference (fails at all frequencies) — A13 Output (fails only \leq 4 GHz) — A14 Extended Frequency Output (fails only $>$ 4 GHz)
Burst Modulation On/Off Ratio	<ul style="list-style-type: none"> • Perform: <ul style="list-style-type: none"> — All Burst adjustments • If failing, troubleshoot the following assemblies: <ul style="list-style-type: none"> — A18 Reference (fails at all frequencies) — A13 Output (fails only \leq 4 GHz) — A14 Extended Frequency Output (fails only $>$ 4 GHz)
CDMA Adjacent Channel Power— E4438C Only (Not Used with Option UNB or Option 506) Used for Option 401 Only with CDMA 2000.	<ul style="list-style-type: none"> • Perform: <ul style="list-style-type: none"> — All I/Q adjustments • If failing, troubleshoot the following assemblies: <ul style="list-style-type: none"> — A7 Baseband Generator (fails at all frequencies) — A10 I/Q Multiplexer — A13 Output (fails only \leq 4 GHz) — A14 Extended Frequency Output (fails only $>$ 4 GHz)
WCDMA Adjacent Channel Power — E4438C Only (Not Used with Option UNB or Option 506) Used for Option 400 Only.	<ul style="list-style-type: none"> • Perform: <ul style="list-style-type: none"> — All I/Q adjustments • If failing, troubleshoot the following assemblies: <ul style="list-style-type: none"> — A7 Baseband Generator (fails at all frequencies) — A10 I/Q Multiplexer — A13 Output (fails only \leq 4 GHz) — A14 Extended Frequency Output (fails only $>$ 4 GHz)
Alternate Timeslot Power Settling Time (Not Used with Option UNB or Option 506)	<ul style="list-style-type: none"> • Perform: <ul style="list-style-type: none"> — No adjustments • If failing, troubleshoot the following assemblies: <ul style="list-style-type: none"> — AT1 Electronic Attenuator or AT1 High-Power Mechanical Attenuator — A13 Output

Troubleshooting Performance Test Problems

Performance test that is failing...	Action to perform...
<p>Dual Arbitrary Waveform Generator Check — E4438C Only</p> <p>Used for Option 001/601 or Option 002/602 Only.</p>	<ul style="list-style-type: none"> • Perform: <ul style="list-style-type: none"> — All I/Q adjustments • If failing, troubleshoot the following assemblies: <ul style="list-style-type: none"> — A7 Baseband Generator (fails at all frequencies) — A10 I/Q Multiplexer
<p>GSM Loopback BER Check (Option 300 Only — E4438C Only)</p>	<ul style="list-style-type: none"> • Perform: <ul style="list-style-type: none"> — All I/Q adjustments — Internal Digital Modulation Quality (Option 402 Only) • If the Internal Digital Modulation Quality (Option 402 Only) performance test passes, troubleshoot the following assemblies: <ul style="list-style-type: none"> — A9 Digital Demodulator — A11 Internal Bit Error Rate Analyzer — A20 Downconverter

Troubleshooting Harmonic Spurious

Harmonics are multiples of the fundamental output frequency produced by a signal generator. Specifically, the second harmonic is two times the output frequency and its amplitude is measured relative to the fundamental (carrier) output frequency's amplitude; the power level of a harmonic is expressed as $-xx$ dBc.

- If the frequency of a harmonic falls beyond the frequency range of a signal generator, that particular harmonic is not specified or measured.
- If the frequency of a harmonic falls within the frequency range of a signal generator, the harmonic's power level is obtained with the following procedure:
 1. The signal generator and spectrum analyzer are initially set to the same harmonic frequency.
 2. The signal generator is also set to a specific power level and its output peak power level is measured on the spectrum analyzer; this peak power level is the reference level used for the harmonic measurement.
 3. The signal generator is then set to the fundamental frequency and the power level of the fundamental frequency is measured by using **Peak Search** and **Marker Delta**.

This measurement obtains the power level of the harmonic and is expressed as a dBc value; it is the difference between the fundamental peak power level and the harmonic frequency power level.

Troubleshooting Harmonic Spurious by Fundamental Frequency

Because the RF Output frequency is derived from a mixer on the A13 Output and the A14 Extended Frequency Output, harmonic spurious problems are determined by the frequency range of their fundamental frequency.

Fundamental Frequencies \leq 250 MHz

Problems with the RF Output frequency \leq 250 MHz are most likely the A13 Output.

Fundamental Frequencies $>$ 250 MHz and \leq 3 GHz

Problems with frequencies $>$ 250 MHz and \leq 3 GHz are best determined by measuring the harmonic levels at both the RF Output and the Coherent Carrier outputs with the following procedures:

- [“To Verify Harmonic Performance at the RF Output” on page 1-98](#)
- [“To Verify Harmonic Performance at the Coherent Carrier Output” on page 1-98](#)

Fundamental Frequencies $>$ 3 GHz

The harmonic frequency is outside the upper frequency limit of the Agilent E4428C/38C ESG signal generator and is therefore not specified.

To Verify Harmonic Performance at the RF Output

1. Signal Generator Settings
 - a. Set the frequency of the *signal generator* to the harmonic frequency being measured. For example, when planning to measure the second harmonic of a 1 GHz signal, set the frequency of the *signal generator* to 2 GHz.
 - b. Set the power level of the *signal generator* to +4 dBm (+7.5 dBm for Option UNB).
2. Spectrum Analyzer Settings
 - a. Connect a *spectrum analyzer* to the RF Output connector of the signal generator.
 - b. Set the frequency of the spectrum analyzer to the harmonic frequency being measured. To continue with our example, set the frequency of the spectrum analyzer to 2 GHz.
 - c. On the *spectrum analyzer*, press the **Peak Search** and **Marker Delta** keys. The Marker should indicate approximately 0 dBm.
3. Signal Generator Settings
 - a. Set the *signal generator* to the fundamental frequency of the harmonic being measured. In this example, because the measured harmonic was at 2 GHz, the *signal generator* should be set to 1 GHz.
4. Spectrum Analyzer Settings
 - a. On the *spectrum analyzer*, read the power level (and record it for future reference in case further troubleshooting is necessary). The Marker should indicate a power level in dBc; this is the power level of the harmonic being measured.
 - b. Compare the power level of the Marker against the specified harmonic performance level for your signal generator.

To Verify Harmonic Performance at the Coherent Carrier Output

1. Signal Generator Settings
 - a. Set the frequency of the *signal generator* to the fundamental frequency being measured. For example, when planning to measure the second harmonic of a 1 GHz signal (which would be 2 GHz), set the frequency of the *signal generator* to 1 GHz.
 - b. Set the power level of the *signal generator* to +4 dBm (+7.5 dBm for Option UNB).
2. Spectrum Analyzer Settings
 - a. Connect a *spectrum analyzer* to the Coherent Carrier Output connector of the signal generator.
 - b. Set the frequency of the spectrum analyzer to the fundamental frequency being measured. To continue with our example, set the frequency of the spectrum analyzer to 1 GHz.
 - c. Press the **Peak Search** and **Marker Delta** keys. The Marker should indicate approximately 0 dBm.
 - d. Set the frequency of the spectrum analyzer to the harmonic frequency being measured. To continue with our example, set the frequency of the spectrum analyzer to 2 GHz.
 - e. Press the **Peak Search** key and read the power level (and record it for future reference in case further troubleshooting is necessary). The Marker should indicate the harmonic power level in dBc.
 - f. Compare the power level of the Marker against the specified harmonic performance level for your signal generator. Filtering on the A13 Output should improve the harmonic performance at the RF Output versus the Coherent Carrier output. However, the magnitude of this difference changes with frequency and actual harmonic content. Therefore, it is hard to define an absolute acceptable harmonic level at the Coherent Carrier output.

- If the harmonic level at the Coherent Carrier output is significantly higher than the harmonic level of the RF Output, the most likely causes are one of the following:
 - Signal Generators with Option 501, 502, 503, 504, replace the A17 Synthesizer followed by the A13 Output. (Refer to “A17 Synthesizer” on page 3-44 and “A13 Output” on page 3-36.)
 - Signal Generators with Option UNJ or Option 506, replace the A16 Frac-N followed by the A13 Output. (Refer to “A16 Frac-N” on page 3-42 and “A13 Output” on page 3-36.)

Troubleshooting Non-Harmonic Spurious

There are many different groupings a spur can fall into. The grouping determines what assembly is most likely generating the spur. Each data point in the service software test report indicates what type of spur is tested. The procedure for troubleshooting spurs is to identify the grouping based on failing a performance test, checking for loose or broken cables or castings, and replacing the assembly.

Table 1-40

Type of Spur	Options	Description
Mixing Spurs	All	<p>These spurs are generated by the mixing products of the RF and IF signals on the A13 Output. The instrument is tuned to a frequency in the Heterodyne-Band (≤ 250 MHz) to measure these spurs.</p> <p>The most likely cause is the A13 Output.</p>
Power Supply Spurs	All	<p>These spurs are generated by the power supply switching at a 75 kHz rate.</p> <p>The most likely cause is the A6 Power Supply.</p>
Offset Reference Spurs	All	<p>These spurs are generated by the 10 MHz frequency reference on the A18 Reference.</p> <p>The most likely cause is the A18 Reference.</p>
Frac-N Spurs	All	<p>These spurs are generated by the Frac-N phase-lock loop. They show up at a small offset from the carrier, so they are checked at a 3 kHz offset.</p> <p>The most likely cause is the A16 Frac-N or the A17 Synthesizer.</p>
Sampler Spurs	Option UNJ and Option 506	<p>These spurs are generated when the sampler IF frequency, divided by two, equals a harmonic of the sampling frequency.</p> <p>The most likely cause is the A15 Sampler.</p>
F/2 Spurs	All	<p>These spurs are exactly one half of the RF output frequency.</p> <p>If these spurs occur, perform the VCO Bias Potentiometer Calibration. If the spurs still occur, the most likely cause is the A17 Synthesizer or the A16 Frac-N.</p>
Comb Feedthrough	Option UNJ and Option 506	<p>These spurs are harmonics of the sampling frequency and are at an absolute frequency, not at an offset from the carrier.</p> <p>The most likely cause is the A15 Sampler.</p>

Table 1-40

WCDMA (E4438C Only)	Option 400	<p>These spurs are offset spurs that are generated when the WCDMA modulation format is running.</p> <p>The most likely cause is the A7 Baseband Generator.</p>
Baseband Generator Sideband Spurs (E4438C Only)	Option 001/601 or Option 002/602	<p>These spurs are mixing spurs that are generated by the baseband generator at offsets up to 2.5 MHz. A modulation format must be running to generate these spurs.</p> <p>The most likely cause is the A7 Baseband Generator.</p>
Baseband Generator Bit Clock Spurs (E4438C Only)	Option 001/601 or Option 002/602	<p>These spurs occur at the symbol rate of a digital modulation format. A modulation format must be running to generate these spurs.</p> <p>The most likely cause is the A7 Baseband Generator.</p>

Troubleshooting Phase Noise (Option UNJ and Option 506 Only)

Poor grounding or shielding problems in either the test environment or the measurement system can cause the phase noise measurement to fail. Physical vibration is another common cause of phase noise. Before performing a phase noise measurement, assure that all instrument covers are installed, the work surface is free of physical vibrations, and the phase noise system is working properly.

Phase noise failures at specific offsets are fairly predictable. After assuring that the phase noise measurement accurately reflects a failure, use [Table 1-41](#) to troubleshoot phase noise problems. The troubleshooting procedure consists of assembly substitution.

Table 1-41

Frequency Offset...	Most Likely Assembly Causing Phase Noise Failure...
0 to 10 kHz	A18 Reference
>10 kHz to 100 kHz	A15 Sampler
>100 kHz to 1 MHz	A21 YTO Driver
Frequencies \leq 4 GHz	A13 Output
Frequencies > 4 GHz	A14 Extended Frequency Output

Troubleshooting Pulse Modulation and LF Out

The pulse waveform originates on the A23 Motherboard, is routed through the A18 Reference, and then is routed out to the A13 Output and A14 Extended Frequency Output. When pulse modulation is switched on, the pulse waveform is used to turn on and off the burst modulator on the A13 Output and A14 Extended Frequency Output.

To configure the signal generator for pulse mode and check the pulse waveform on an oscilloscope from the front panel LF Out:

1. Press the **Pulse** hardkey and the **Pulse On** softkey.
2. Press the **LF Out** hardkey and the **LF Out On** softkey.
3. Press the **LF Out Amplitude** softkey and use the numeric keypad to enter **5 Vp**.

There should be a square wave on the oscilloscope with a period of 80 us and an amplitude of approximately 10 Vpp. The period and pulse width of the pulse waveform may be varied using softkeys under the **Pulse** menu.

- If the pulse waveform is good at the LF Out port, check it at the A19 Daughterboard with one of the following procedures:
 - [“To Verify the Pulse Waveform at the A19 Daughterboard \(All Options\)” on page 1-103](#)
 - [“To Verify the Pulse Waveform at the A19 Daughterboard \(Option 506 Only\)” on page 1-105](#)
- If there is no pulse waveform at the LF Out port, proceed to [“No Pulse Signal from LF Out” on page 1-106](#).

To Verify the Pulse Waveform at the A19 Daughterboard (All Options)

1. Turn power off to the signal generator.
2. Remove the A13 Output.
3. Install a ribbon cable extender¹ into J12 on the A19 Daughterboard.

J12 is a 30-pin connector and the ribbon cable extender has only 20 pins. Align the ribbon cable extender with the pins on the left side of J12. When the ribbon cable extender is properly installed, you will see two rows (5 pins each) on the right-side of the ribbon cable extender.

1. The ribbon cable extender needs to be assembled by the user. It consists of two connector plugs (part number 1252-1010) and approximately eight inches of ribbon cable (part number 8120-2226). The ribbon cable contains 26 wires; six of these wires need to be stripped off before being connected to the plugs.

Figure 1-26

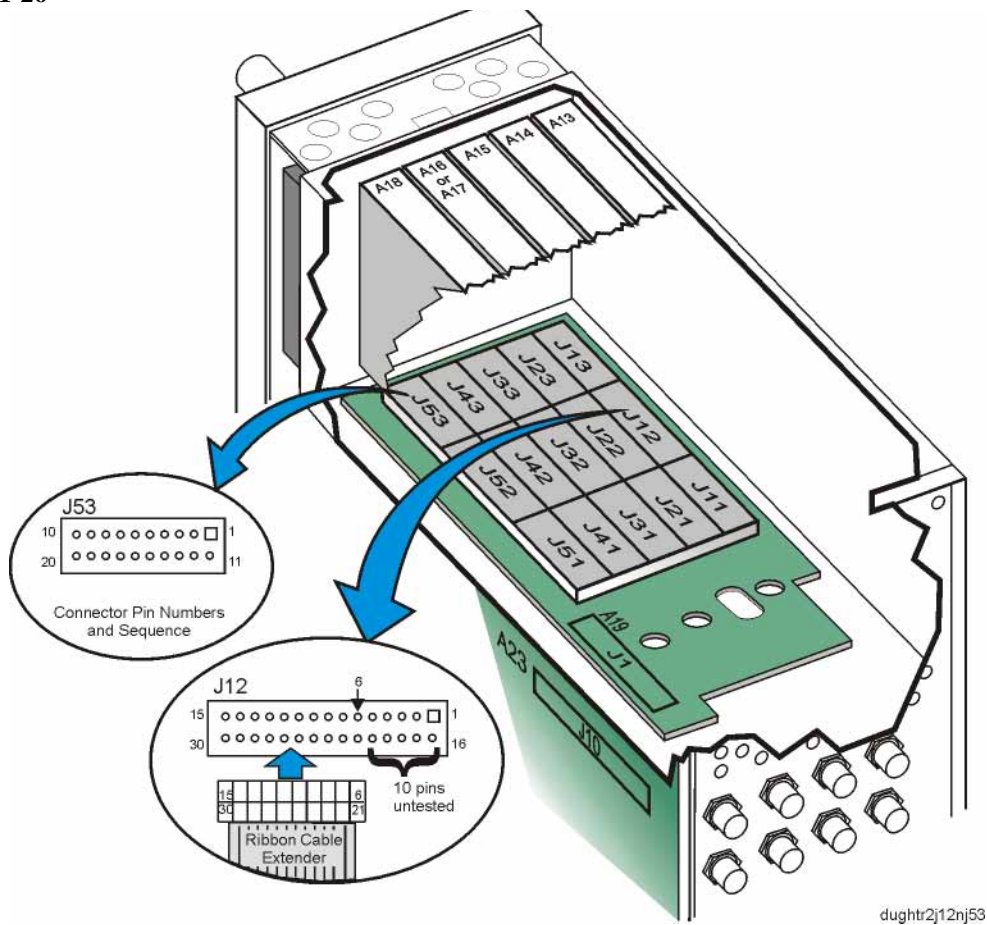

4. Turn power on to the signal generator and configure it for pulse mode.
 - a. Press the **Pulse** hardkey and the **Pulse On** softkey.
 - b. Press the **LF Out** hardkey and the **LF Out On** softkey.
 - c. Press the **LF Out Amplitude** softkey and use the numeric keypad to enter **5 Vp**.
5. Use an oscilloscope and probe J12-23.

There should be a square wave with a period of 80 us and an amplitude of approximately 5 Vpp. The period and pulse width of this signal may be varied using softkeys under the **Pulse** menu.

- If the signal is present, replace the A13 Output. (Refer to [“A13 Output”](#) on page 3-36.)
- If the signal is not present:
 - a. Turn power off to the signal generator.
 - b. Remove the A18 Reference. (Refer to [“A18 Reference”](#) on page 3-46.)
 - c. Insert a second ribbon cable extender into J53 on the A19 Daughterboard.
 - d. Measure the resistance between J12-23 and J53-7 on the A19 Daughterboard.
 - If the path is good, replace the A18 Reference. (Refer to [“A18 Reference”](#) on page 3-46.)
 - If the path is bad (open), replace the A19 Daughterboard. (Refer to [“A19 Daughterboard”](#) on page 3-48.)

To Verify the Pulse Waveform at the A19 Daughterboard (Option 506 Only)

1. Turn power off to the signal generator.
2. Remove the A14 Extended Frequency Output.
3. Install the ribbon cable extender¹ into J22 on the A19 Daughterboard.

J22 is a 30-pin connector and the ribbon cable extender has only 20 pins. Align the ribbon cable extender with the pins on the left side of J22. When the ribbon cable extender is properly installed, you will see two rows (5 pins each) on the right-side of the ribbon cable extender.

Figure 1-27

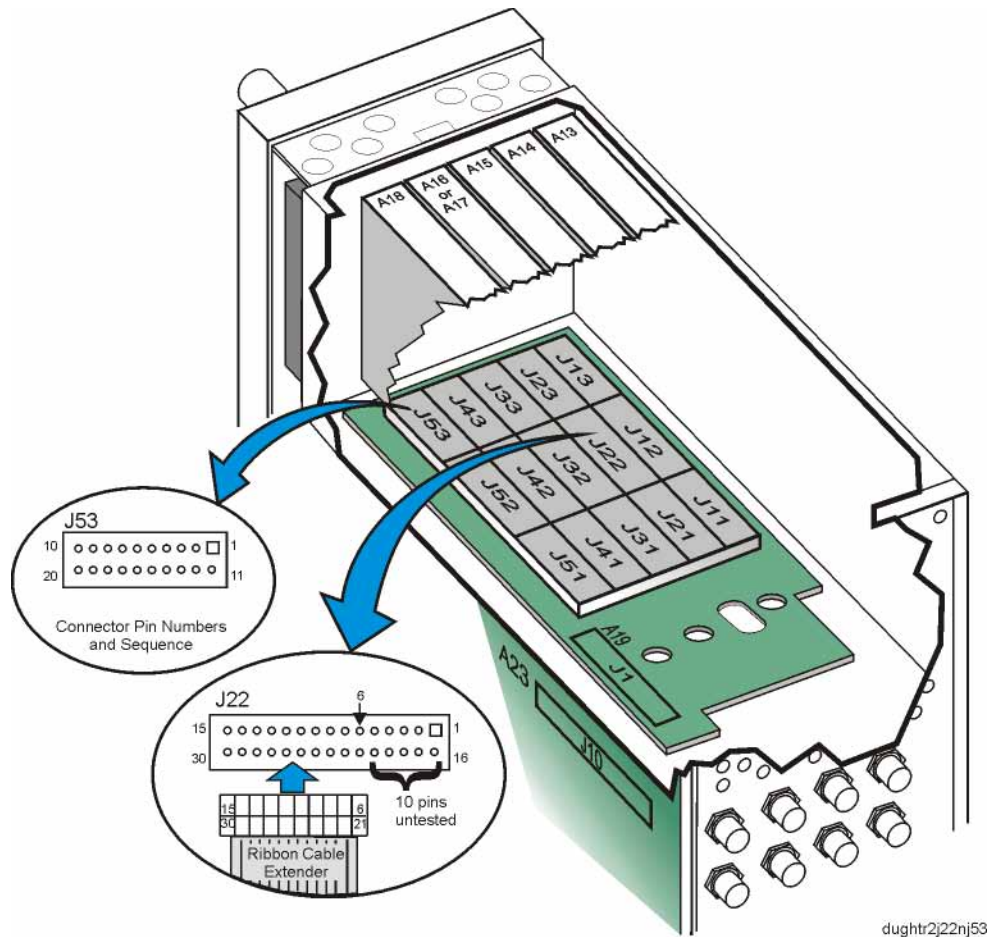

1. The ribbon cable extender needs to be assembled by the user. It consists of two connector plugs (part number 1252-1010) and approximately eight inches of ribbon cable (part number 8120-2226). The ribbon cable contains 26 wires; six of these wires need to be stripped off before being connected to the plugs.

Troubleshooting Pulse Modulation and LF Out

4. Turn power on to the signal generator and configure it for pulse mode.
 - a. Press the **Pulse** hardkey and the **Pulse On** softkey.
 - b. Press the **LF Out** hardkey and the **LF Out On** softkey.
 - c. Press the **LF Out Amplitude** softkey and use the numeric keypad to enter **5 Vp**.
5. Using an oscilloscope, probe J22-23.

There should be a square wave with a period of 80 us and an amplitude of approximately 5 Vpp. The period and pulse width of this signal may be varied using softkeys under the **Pulse** menu.

- If the signal is present, replace the A14 Extended Frequency Output. (Refer to [“A14 Extended Frequency Output” on page 3-38.](#))
- If the signal is not present:
 - a. Turn power off to the signal generator.
 - b. Remove the A18 Reference.
 - c. Insert a second ribbon cable extender into J53 on the A19 Daughterboard.
 - d. Ohm between J22-23 and J53-7 on the A19 Daughterboard.
 - If the path is good, replace the A18 Reference. (Refer to [“A18 Reference” on page 3-46.](#))
 - If the path is bad (open), replace the A19 Daughterboard

No Pulse Signal from LF Out

To function, the internal pulse generator on the A23 Motherboard requires a 10 MHz reference signal from the A18 Reference.

1. Assure that all self-tests have passed.
2. If an external 10 MHz reference is connected to the rear panel of the signal generator, remove the connection.
3. Use an oscilloscope and probe J10-99 of the A23 Motherboard.

There should be a 10 MHz sine wave with an amplitude > 1.2 Vpp.

- If the signal is good at J10-99, use the oscilloscope to probe J10-50.

There should be a square wave with a period of 80 us and an amplitude of approximately 5 Vpp. The period and pulse width of this signal may be varied using softkeys under the **Pulse** menu.

- If the signal is good at J10-50:
 - a. Turn power off to the signal generator.
 - b. Remove the A18 Reference.
 - c. Insert a ribbon cable extender¹ into J53.
 - d. Measure the resistance between J10-50 and J53-6.

1. The ribbon cable extender needs to be assembled by the user. It consists of two connector plugs (part number 1252-1010) and approximately eight inches of ribbon cable (part number 8120-2226). The ribbon cable contains 26 wires; six of these wires need to be stripped off before being connected to the plugs.

- If the path is good between J10-50 and J53-6, measure the resistance between the center conductor of the LF Out and J53-13.
 - If the path is good between the center conductor of the LF Out and J53-13, replace the A18 Reference. (Refer to [“A18 Reference” on page 3-46.](#))
 - If the path is bad (open) between the center conductor of the LF Out and J53-13, replace the A19 Daughterboard. (Refer to [“A19 Daughterboard” on page 3-48.](#))
 - If the path is bad (open) between J10-50 and J53-6, replace the A19 Daughterboard.
- If the signal is not present at J10-50, replace the A23 Motherboard. (Refer to [“A23 Motherboard” on page 3-56.](#))
- If the signal is not present at J10-99:
 - a. Turn power off to the signal generator.
 - b. Remove the A18 Reference.
 - c. Insert the ribbon cable extender into J51 on the A19 Daughterboard.
 - d. Measure the resistance between J10-99 and J51-7 on the A19 Daughterboard.
 - If the path is good, replace the A18 Reference. (Refer to [“A18 Reference” on page 3-46.](#))
 - If the path is bad (open), replace the A19 Daughterboard. (Refer to [“A19 Daughterboard” on page 3-48.](#))

Troubleshooting I/Q Calibration (E4438C Only)

There are various reasons for an I/Q calibration failure. When a failure does occur, it is typically caused by one of the following problems:

- low power
- offset voltage that cannot be nulled
- bad adjustment or a component defect on one of the following assemblies:
 - A10 I/Q Multiplexer
 - A13 Output
 - A14 Extended Frequency Output (Option 506)
 - A16 Frac-N (Option UNJ) or A17 Synthesizer

During the full I/Q calibration, the signal generator repeatedly tests and adjust many aspects of the signal generator I/Q signal path that includes:

- Full frequency range
- I and Q paths and offsets
- Output board and I/Q mux DACS
- I/Q modulator attenuators
- I/Q modulator filters
- I/Q modulator

Most of the paths route through multiple assemblies and are internal to the signal generator, which makes them difficult to check manually.

During the calibration, the signal generator does not use the baseband generator (BBG) and it disables the RF OUTPUT connector. To perform the calibration, the I/Q Multiplexer uses a voltage source on its board to generate a dc level signal that tests the I and Q paths, which includes the I/Q modulator on the output board. At the same time, the signal generator uses a swept signal to stress the A16, A17 and A22 assemblies, depending on the option mix, which also provides the final component to test the I/Q modulator. The signal generator outputs this swept signal through the COH CARRIER connector, which has a limited frequency range of 250.00001 MHz to 4 GHz.

Pre-Troubleshooting Checklist

If you perform a corrective action for an item in this checklist, rerun the full I/Q calibration. If this checklist does not apply or a corrective action as outlined in this checklist fails to correct the condition, then troubleshoot the I/Q calibration failure using the steps found in [I/Q Calibration Troubleshooting on page 1-109](#).

- o For any repairs just completed, ensure that all post-repair adjustments have been performed.
- o Ensure that all internal cables are undamaged and properly seated.
- o For a BBG board replacement:
 - Ensure that the firmware revision matches the baseband generator FPGA code version:
 1. Press **Utility > Instrument Info/Help Mode > Diagnostic Info**.
 2. On the display, obtain the installed firmware version from the line `Firmware Revision`.
 3. Match the firmware version number with the `DG.xx.xx` version found in the line `Baseband Generator 1`.
Example of a match: `Firmware Revision–C.04.86` `Baseband Generator 1–DG.04.86`
 4. If the they do not match, download the latest or required (per customer needs) signal generator firmware package,

which includes the BBG code, from Agilent’s website www.agilent.com/find/esg.

— For BBG Option 601 or 602, ensure that only one BBG option shows in the options list:

1. Press **Utility > Instrument Info/Help Mode > Diagnostic Info**.
2. On the display, view the current option numbers shown in the Options line.
3. If both BBG option numbers appear in the list, obtain the Options 601 and 602 upgrade kit installation note, part number E4400-90585, and perform the following steps:
 - a. Verify the material list to ensure that the correct board was installed for the signal generator serial number.
 - b. Initialize the BBG option.

— For E4438C signal generators with serial numbers equal to or greater than MY4426 or US4426, verify the installation of the license key; an earlier serial number does not require a license key.

1. Press **Utility > Instrument Adjustments > Instrument Options > Software Options**.
2. On the display, check for the installation of the BBG license key.
3. If there is no license key, install the license key.

I/Q Calibration Troubleshooting

Use this section after completing the [“Pre-Troubleshooting Checklist” on page 1-108](#).

1. For the output board, verify that the open and closed loop power levels pass.
 To check the power levels, perform the performance tests shown in [Table 4-3, on page 4-5](#).
2. Run the full I/Q Calibration, and in the status bar that appears on the front panel display, record the percentage value at the point of failure.
 The calibration status bar disappears when the test either stops due to a failure or upon successful completion of the I/Q Calibration routine.
3. Determine what assemblies may be involved in the failure. Because of the complexity of the internal tests and the numerous test repetitions, the following list along with the error codes shown in [Step b](#) provide only a hint as to where to begin troubleshooting:
 - a. Compare the percentage value obtained in [Step 2](#) with the table below to help determine what part of the test was being performed at the point of failure.

Percentage of Completion	Calibration Test Routine
1–7	initialization and rms cal
	mux path 1 and 2, and the I & Q attenuator cal
	ext out I & Q attenuator cal
7–10	low-band quadrature/offset RF cal
10–16	low-band through path offset RF cal
16–30	low-band 40 MHz filter offset RF cal
30–40	hi-band quadrature/offset RF cal
40–45	hi-band through path offset RF cal

Percentage of Completion	Calibration Test Routine
45–50	hi-band 40 MHz path offset RF cal
50–51	adjust system after quadrature/offset cals
51–66	mux offset cal
66–83	low-band gain main RF cal
83–100	hi-band gain main RF cal

b. View the error message that was generated with the failure:

Press **Utility > Error Info**.

- For firmware versions earlier than C.04.10, the error message shows two values, for example 26, 5. The first number is the error code and the second number is an iteration error. The iteration error states what happened with the DAC after the routine ran several iterations without being able to correct the error. While the iteration error is not needed for troubleshooting, it needs to be submitted with the failed assembly for root cause troubleshooting.

Error Code	Error Message
0	failed accessing I/Q cal constants cal array
1	failed accessing I/Q index cal array
2	I_ref_value is out of tolerance
3	Q_ref_value is out of tolerance
4	I_ref_value is out of tolerance
5	Q_ref_value is out of tolerance
6	I_ref_value is out of tolerance
6	Q_ref_value is out of tolerance
28	error occurred during the last part of hi-band gain cal
23	iteration failure on I/Q gain
99	iteration to address tolerance failure passed 30
26	error in minimize offset
27	failure in adjust measure
29	error trying to store cal arrays
30	error trying to store cal arrays
31	error trying to get a cal array
32	error trying to get a cal array

Iteration Code	Iteration Message
1	bounded
2	no solution
3	bound violation
4	DAC railed high
5	DAC railed low

NOTE If errors 29 through 32 occur, the probable cause is either the A23 Mother board or the A12 CPU board.

4. Further isolate the cause of the failure to a specific frequency band by running the I/Q Calibration over specific

user-defined frequency ranges:

- a. In the I/Q Calibration menu, press **Calibration Type DC User Full** to User.

The **Start Frequency** and **Stop Frequency** softkeys become active.

- b. Execute the calibration for each frequency range shown in the following table.

Table 1-42 Frequency Bands

Frequency Range ^a	A16 Frac-N Divide By ^b	A17 Synthesizer Divide/Multiply By
250 kHz–250 MHz	8	2
250 MHz –500 MHz	16	2
500 MHz–1 GHz	8	Main
1 GHz–2 GHz	4	x2
2 GHz–3 GHz	2	x4
3 GHz–4 GHz	2	x4
4.0001 GHz–6 GHz ^c	Main	N/A

a. Maximum frequency depends on the installed frequency option (501, 503, 504, or 506).

b. Option UNJ assembly.

c. Uses the main frequency band out of the YIG oscillator through a coupler to the extended frequency (high-band) output board.

- For the frequency bands from 250 kHz to 4 GHz:
 - If at least one band passes along with a failure in one or more of the other bands, the probable cause is the A16 Frac-N or A17 Synthesizer board depending on the option configuration. Use the procedure “[Validating an A16 Frac-N or A17 Synthesizer Failure](#)” on page 1-112 to verify the diagnosis.
 - If all bands fail, the probable cause could be any one of the following boards: A16 Frac-N or A17 Synthesizer, A13 Output board, or A10 I/Q Multiplexer. Perform the following steps to make the repair:
 1. Replace one of the boards.
 2. Perform any required post-repair adjustments.
 3. Run the I/Q Calibration.
 4. If the I/Q calibration failure persists, repeat Step 1 through Step 3 for each board.
- If the 4.0001 GHz to 6 GHz band fails, the probable cause is the A14 Extended Frequency Output board or the A21 YTO Driver assembly. Perform the following steps to make the repair:
 1. Replace the A14 Extended Frequency Output board.
 2. Perform any required post-repair adjustments.
 3. Run the I/Q Calibration.
 4. If the failure persists, perform Step 1 through Step 3 for the A21 YTO Driver assembly along with the A22 Coupler.

5. Check the rear-panel I and Q output paths:
 - a. Press **Mode** > **Custom** > **Real Time I/Q Baseband** > **Data** > **FIX4**.
 - b. Ensure that **FIX4** is set to all zeros.
 - c. Press **Return** > **Custom Off On** to On.
 - d. Connect the rear-panel I and Q signals to channel 1 and channel 2 of an oscilloscope.
 - e. Check the signals to ensure that they are in quadrature, have the same amplitude, and exhibit no dc offset.
 - If there is no output signal for either I or Q, or both, the cause is the A10 I/Q Multiplexer board.
 - If there are signals, but they do *not* appear as stated in [Step e](#), perform the following steps to correct the failure.
 1. Replace the A10 I/Q Multiplexer board.
 2. Perform the A10 board post-repair adjustments.
 3. Run a full I/Q calibration.
 4. If failure persists, perform the baseband troubleshooting, “[Self-Tests 16xx for the A7 Baseband Generator \(E4438C Only\)](#)” on [page 1-56](#) and finish the remaining steps in this procedure.
 5. Run a full I/Q calibration.
 6. If the test fails, contact Signal Sources Division by E-mail at PGU,Sources.

Validating an A16 Frac-N or A17 Synthesizer Failure

From [Step 4](#) of “[I/Q Calibration Troubleshooting](#)” on [page 1-109](#), if a failure occurs in the 250 kHz to 4 GHz range and at least one band in the range passes, use this procedure to verify that the A16 Frac-N (Option UNJ) or A17 Synthesizer assembly is the cause of the failure.

1. Connect a spectrum analyzer to the rear-panel COH CARRIER connector.
2. Set the spectrum analyzer to a 20 MHz span.
3. Using the **Frequency** hardkey, set the signal generator to a frequency within the first range shown in the following table.

Table 1-43 Frequency Bands for Board Failure Verification

Frequency Range ^a	A16 Frac-N Divide By ^b	A17 Synthesizer Divide/Multiply By
300–400 MHz	16	2
550–900 MHz	8	Main
1.2–2.0 GHz	4	x2
3.1–3.95 GHz	2	x4

a. Maximum frequency depends on the installed frequency option (501, 503, 504, or 506).
 b. Option UNJ assembly.

4. Set the spectrum analyzer’s center frequency to match the signal generator’s CW frequency.
5. View the signal for the proper signal attributes:
 - power level of approximately –6 dBm
 - CW signal frequency is the same as that set on the signal generator
 - no sidebands, spuriousness, or harmonics

If the coherent carrier output does not exhibit these attributes, the probable cause is the A16 Frac-N board or the A17 Synthesizer board.

6. Repeat [Step 3](#) through [Step 5](#) for each frequency range shown in [Table 1-43](#).

Contacting Agilent Technologies

If you should have a problem with your signal generator, contact your nearest sales and service offices. Please be prepared to provide the following information:

- a complete description of the failure
- is there a reported failure (Y or N) and what is the failure being reported
- was the failure dead on arrival (DOA) or did the instrument work before use
- the model number, all options, and serial number of the instrument
- the firmware revision date
- has self-test been run (Y or N)

Review the Warranty

If there is still a problem, refer to the warranty information that is shipped with your signal generator. If your signal generator is covered by a separate maintenance agreement, be familiar with its terms.

Agilent Technologies offers several maintenance plans to service your signal generator after warranty expiration. Call your Agilent Technologies sales and service office for full details.

Contacting Agilent Sales and Service Offices

Before contacting Agilent, read the warranty information that is shipped with your signal generator. If your signal generator is covered under a maintenance agreement, be familiar with its terms.

Assistance with test and measurements needs, and information on finding a local Agilent office is available on the Web at:
<http://www.agilent.com/find/assist>

If you do not have access to the internet, contact your local field engineer.

NOTE In any correspondence or telephone conversation, refer to the signal generator by its model number and full serial number. With this information, the Agilent representative can determine whether your unit is still within its warranty period.

Important Information Needed by an Agilent Service Representative

Be as specific as possible about the nature of the problem and include information such as:

- any error messages that appeared on the signal generator
- a complete performance test record from the calibration guide for your signal generator
- any other specific data on the performance of the signal generator

Returning a Signal Generator for Service

Use the information in this section if you need to return the signal generator to Agilent Technologies.

Packaging the Signal Generator

1. Use the original packaging materials or a strong shipping container that is made of double-walled, corrugated cardboard with 159 kg (350 lb.) bursting strength. The carton must be both large enough and strong enough to accommodate the signal generator and allow at least 3 to 4 inches on all sides of the signal generator for packing material.

CAUTION Signal generator damage can result from using packaging materials other than those specified. Never use styrene pellets, in any shape, as packaging materials. They do not adequately cushion the instrument or prevent it from shifting in the carton. Styrene pellets cause equipment damage by generating static electricity and by lodging in the signal generator fan.

2. Surround the instrument with at least 3 to 4 inches of packing material, or enough to prevent the instrument from moving in the carton. If packing foam is not available, the best alternative is SD-240 Air Cap™ from Sealed Air Corporation (Hayward, CA 94545). Air Cap looks like a pink plastic sheet covered with 1-1/4 inch air-filled bubbles. Use the Air Cap to reduce static electricity. Wrap the instrument several times in the material to both protect the instrument and prevent it from moving in the carton.
3. Seal the shipping container securely with strong, nylon adhesive tape.
4. Mark the shipping container “FRAGILE, HANDLE WITH CARE” to ensure careful handling.
5. Retain copies of all shipping papers.

Block Descriptions

This section contains block descriptions for all of the functional blocks in a signal generator:

- [“Overall Block Description for Option 501, 502, 503, 504” on page 1-116](#)
- [“Frequency Synthesis Block Description for Option 501, 502, 503, 504” on page 1-121](#)
- [“RF Path Block Description for Option 501, 502, 503, 504” on page 1-125](#)
- [“Overall Block Description for Option UNJ and Option 506” on page 1-129](#)
- [“Frequency Synthesis Block Description for Option UNJ and Option 506” on page 1-135](#)
- [“RF Path Block Description for Option UNJ or Option 506” on page 1-141](#)
- [“Analog Modulation Block Description for All Options” on page 1-149](#)
- [“Digital Modulation Block Description for All E4438C Options” on page 1-153](#)

Overall Block Description for Option 501, 502, 503, 504

Overview

The objective of this overall block description is to provide a functional overview of the Agilent E4428C/38C ESG Signal Generator with Option 501, 502, 503, and 504. Some of the functional blocks discussed are common to many types of instruments while others are more specific to signal generators.

- Common Functions:
 - Power Supply
 - CPU
 - Input/Output Interface
- Specific Signal Generator Functions:
 - Frequency Generation
 - Output Power Level Control
 - Modulation

A6 Power Supply

The main power supply converts line voltage (120 Vac or 240 Vac) to regulated dc voltages. Some of the required dc voltages are not directly provided by the main power supply and are generated by converting the main power supply voltages. Most of the conversions are performed on the A23 Motherboard, but a few are performed on individual assemblies.

A24 Line Module

The line voltage is connected to the power supply through the A24 Line Module. Line voltage selection isn't required because the A6 Power Supply automatically detects and adjusts to different line voltages. The power supply has an internal line fuse, but if the fuse opens, the power supply must be replaced; it is not field repairable.

A12 CPU

The A12 CPU controls all activities in the signal generator. It translates information entered from the front panel keys, LAN, GPIB, or Auxiliary Interface (RS-232) into machine level instructions and communicates these instructions on the internal buses. The A12 CPU also monitors critical circuits for unlevelled and unlocked conditions and reports these problems on the display.

Input/Output Interface

The Input/Output Interface is located on the front panel and includes the A1 Keyboard, the A2 Display, and the On/Off power switch. The user interface consists of the front panel keypad and the display softkeys. The current signal generator state is displayed on the A2 Display. Above the power switch, are amber and green Light Emitting Diodes (LED). When the amber LED is lit, it indicates that line voltage is present and that the signal generator is in standby mode. When the green LED is lit, it indicates that the signal generator is in the power-on mode.

Front Panel Hardkeys, Softkeys, and Keypad

Some front panel keys are referred to as hardkeys; these keys are dedicated to specific functions. Dedicated hardkeys are used to select the most commonly used features and control the display's contrast and intensity. Front panel keys along the display are referred to as softkeys and are used to select functions; these functions are displayed to the left of each softkey on the display. As softkeys are pressed, their displayed functionality is executed; some of these softkeys have lower-level menus which are displayed when pressed. The front panel has a keypad that uses a row and column configuration. Pressing a key on this keypad makes a connection between a row and column. The row and column information is routed to the A12 CPU where

it is interpreted and the appropriate action is taken.

A2 Display

A Liquid Crystal Display (LCD) provides information about the signal generator's settings and condition. The LCD requires a power supply, lighting, and data. The lighting, supplied from a light bulb on the A2DS1 Display Backlight is powered by the A4 Inverter. The A4 Inverter converts a dc voltage an ac voltage. Data is generated on the A12 CPU and routed to the LCD through the A3 Front Panel Auxilary Board.

A25 Rear Panel Board

The A24 Line Module, LAN, GPIB, and RS-232 connections are located on the A25 Rear Panel Board. On signal generators with Option 1EM, the A25 Rear Panel Board is replaced with the A26 Rear Panel LVDS Board (Option 1EM) and A27 Rear Panel SMB Board (Option 1EM).

RF Output Connector

The RF output connector is a female Type-N. Option 1EM routes the RF output to the signal generator's rear panel.

RF Path - Frequencies 250 kHz to 4 GHz

The output of a Voltage Controlled Oscillator (VCO) is routed to the A13 Output which contains ALC circuitry to maintain power leveling. AM and Pulse modulation are also implemented on the A13 Output. The signal is further conditioned and routed through the optional AT1 Attenuator and to the front panel RF output connector.

For frequencies below 250 MHz, the A13 Output down-converts the RF signal. To accomplish the down conversion, the A18 Reference provides a 1 GHz LO to a mixer on the A13 Output. The resultant IF out of the mixer is then routed to the AT1 Attenuator or to the front panel RF output connector.

Frequency Control

Frequency accuracy and stability are established with the A18 Reference, A17 Synthesizer, and the A12 CPU.

Frequency Generation

The A17 Synthesizer contains a VCO that generates frequencies from 500 MHz to 1 GHz. To maintain frequency accuracy, the VCO is phase locked to a 10 MHz reference from the A18 Reference. To change the output frequency, the VCO tuning voltage is changed. Depending on the output frequency, the VCO frequency is either divided by 2, multiplied by 2 or 4, or left unchanged.

Output Power Leveling/Automatic Leveling Control

Output power control circuitry consists of a detector, integrators, two ALC modulators, and other associated circuitry. This circuitry is commonly referred to as the Automatic Leveling Control (ALC) loop. A small portion of the RF signal is detected and converted to a dc voltage. In closed loop operation, a comparison is made between a reference voltage and the detected voltage. If the detected and reference voltage levels agree, the modulator drive current remains constant. If the detected and reference voltage levels do not agree, the modulator drive current changes causing the RF output power to increase or decrease until the reference and detected voltages agree. In open loop operation or ALC OFF mode, only the reference voltage is used to control the modulation drive current. The reference voltage is determined by the desired power setting and includes the stored calibration data used to compensate for any losses that occur after the detector. The reference voltage is generated on the A13 Output by a DAC and is controlled by the A12 CPU.

Analog Modulation

An *Internal Modulation Source Function Generator*, located on the A23 Motherboard, is used to provide AM, FM, PM, and Pulse modulation capabilities. To improve phase modulation control, this function generator is tied to the 10 MHz reference signal from the A18 Reference. The function generator's signal is routed to the A18 Reference, which contains a multiplexer. The multiplexer is controlled through the front panel and may be used to select the modulation source.

External modulation may be applied through the EXT 1 and EXT 2 front panel inputs. There is also a feature that allows internally generated signals to be routed to the LF Output on the front panel. AM and Pulse modulation signals are routed to the A13 Output while FM and PM modulations are routed to the A17 Synthesizer.

Digital Modulation (E4438C Only)

The A10 I/Q Multiplexer routes the front panel I/Q baseband signals to the A13 Output so that they can be used to modulate the RF signal. The A10 I/Q Multiplexer also routes the front panel I/Q signals to the rear panel. Along with the original I/Q signal, an inverted I/Q signal is available at the rear panel.

If the signal generator contains an A7 Baseband Generator, it may provide the baseband I/Q signals; it also has the capability of burst modulation. The A10 I/Q Multiplexer may select which baseband signal to use and route the signal in the same manner as the external front panel I/Q signals.

The I/Q signals are simultaneously routed by the A10 I/Q Multiplexer to the A18 Reference so they may be used to modulate AM, FM, and PM.

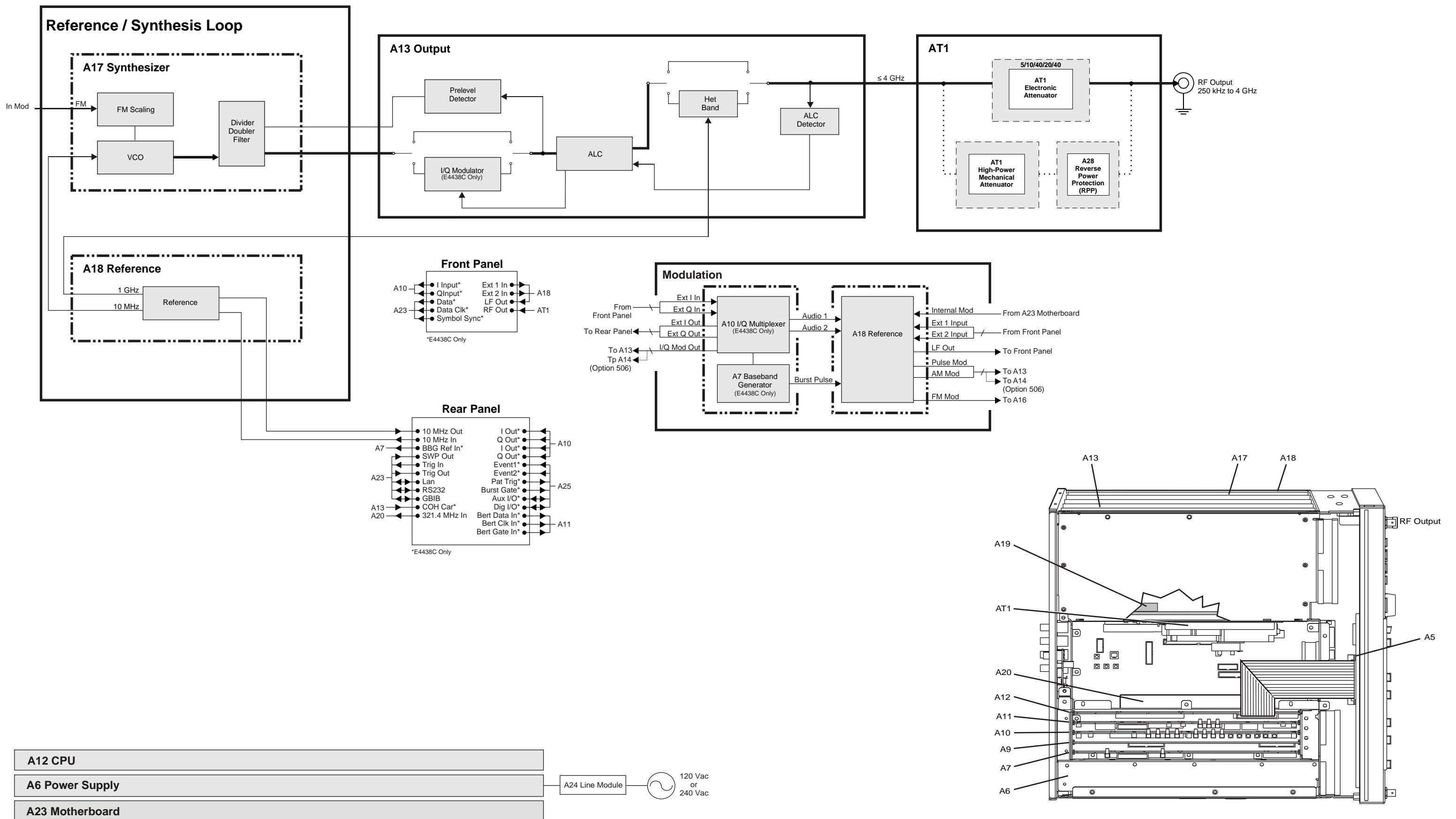

Overall Block Diagram for Option 501, 502, 503, 504

Frequency Synthesis Block Description for Option 501, 502, 503, 504

Overview

Frequency synthesis for Option 501, 502, 503, 504 signal generators is made from portions of the following:

- A18 Reference (Option 501, 502, 503, 504)
or A18 Reference (Option 501, 502, 503, 504 with Option 1E5)
- A17 Synthesizer
- A13 Output (Option 501, 502, 503, 504 or Option UNJ)
or A13 Output (Option UNB)
- A23 Motherboard

The *Frequency Synthesis Block* consists of the A18 Reference and the A17 Synthesizer. Frequency synthesis begins on the A18 Reference with a 10 MHz reference. The A18 Reference has a *Temperature Compensated Xtal Oscillator* (TCXO), while the high stability timebase, A18 Reference (Option 501, 502, 503, 504 with Option 1E5), has an *Oven Controlled Xtal Oscillator* (OCXO). Both references may be phase locked to an external reference or operate stand-alone. The 10 MHz reference phase locks a 1 GHz discrete oscillator on the A18 Reference. The frequency accuracy of the 10 MHz reference is translated to the final output frequency accuracy. The 10 MHz signal is distributed throughout the signal generator. In the following description, the main focus will concentrate on the 10 MHz going to the A17 Synthesizer, but the 10 MHz is also routed to the *Internal Modulation Source Function Generator* located on the A23 Motherboard and routed to the rear panel. The 1 GHz is routed to the heterodyne circuit located on the A13 Output.

The 10 MHz reference is part of a Phase Lock Loop (PLL) circuit located on the A17 Synthesizer. The PLL tunes a Voltage Controlled Oscillator (VCO), which is divided or multiplied to achieve the final RF output frequency.

A18 Reference

Essential to frequency accuracy and low phase noise are clean and stable reference signals. The reference signals on the A18 Reference are a 10 MHz TCXO or OCXO and a 1 GHz discrete oscillator. To minimize frequency drift, the 10 MHz TCXO is tuned by a DAC and the OCXO has an oven to maintain a constant crystal temperature.

If a signal generator with an A18 Reference (Option 501, 502, 503, 504 with Option 1E5) has been without electrical power, a "Reference Oven Cold" warning is displayed when the signal generator is powered on. The warning message is controlled by a timer and should go out after five minutes of being connected to ac power.

The 10 MHz reference may be phase locked to an external 2, 5, or 10 MHz reference. The 10 MHz reference is available at the signal generator's rear panel and may be used to phase lock other instruments in a system. The 10 MHz reference is routed to the A17 Synthesizer and is part of a PLL which is used to tune a VCO.

The 1 GHz discrete oscillator is split into two paths. One path is divided down to 10 MHz and is then phase compared to the 10 MHz signal from the A18 Reference; the difference of this comparison is used to drive an integrator which in turn is used to tune the 1 GHz oscillator and ensure both reference signals are phase locked together. The other path of the 1 GHz signal is routed to the A13 Output.

A17 Synthesizer

The A17 Synthesizer generates the final RF output frequency. Two proprietary application specific integrated circuits (ASIC), named Paren and Tesera, are used to tune a VCO on the A17 Synthesizer. The VCO is capable of being tuned from 500 MHz to 1000 MHz.

The tuning of the VCO begins with a 10 MHz signal from the A18 Reference. The 10 MHz reference is divided down to 5 MHz to reduce fractional spurs in the phase detector. The 5 MHz reference is then phase compared to a divided down VCO output. The primary division of the VCO is performed within the Tesera pre scaler ASIC; the pre scaler divisor is provided by the Paren ASIC. The output of the phase detector is integrated and then used to tune the VCO.

Block Descriptions

Depending on the desired output frequency, the VCO is either divided by two, multiplied by two or four, or left unchanged. The final signal is filtered and routed to the A13 Output.

The baseband FM and PM from the A18 Reference are added to the VCO on the A17 Synthesizer. Depending on the modulation rate, there are two different paths for the modulation to be added to the VCO. If the rate is outside the VCO PLL bandwidth, the baseband signal is scaled and applied to the VCO. If the baseband rate is within the VCO PLL bandwidth, the baseband signal is scaled and sent to the *Sigma-Delta Modulator* for digitizing. The digitized signal is used by Paren and Tesera to change the VCO tuning and implement FM.

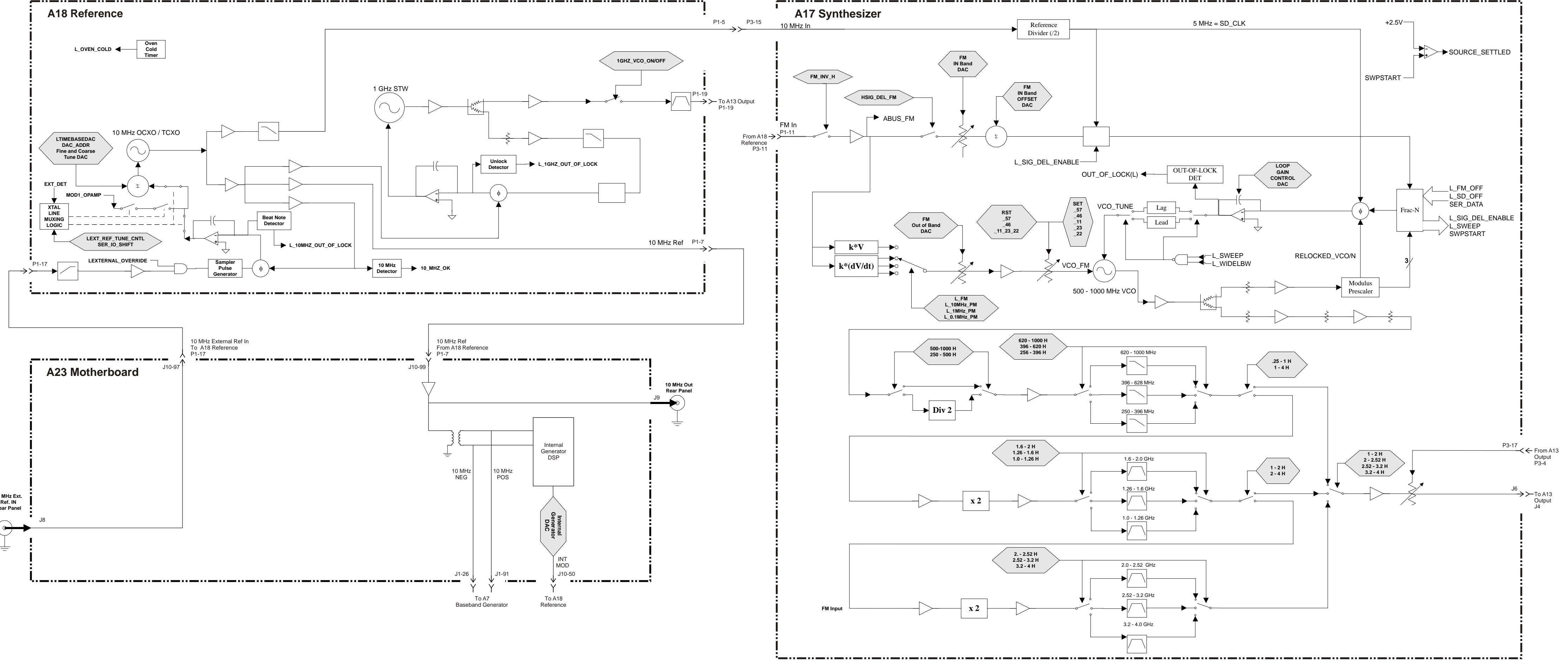

Frequency Synthesis Block Diagram for Option 501, 502, 503, and 504

RF Path Block Description for Option 501, 502, 503, 504

Overview

The RF Path for signal generators with Option 501, 502, 503, 504 is made from portions of the following:

- A18 Reference (Option 501, 502, 503, 504)
or A18 Reference (Option 501, 502, 503, 504 with Option 1E5)
- A17 Synthesizer
- A13 Output (Option 501, 502, 503, 504 or Option UNJ)
or A13 Output (Option UNB)
- AT1 Electronic Attenuator
or AT1 High Power Mechanical Attenuator with A28 Reverse Power Protection

Frequency generation is performed on the A17 Synthesizer with a Voltage Controlled Oscillator (VCO). The signal is routed to the A13 Output which contains the Automatic Level Control (ALC) loop for maintaining leveled power.

When producing RF frequencies below 250 MHz, a heterodyne mixer located on the A13 Output is switched into the RF path. The RF signal is mixed with a 1 GHz LO, provided by the A18 Reference, to produce the final 100 kHz to < 250 MHz output; specifications apply to frequencies \geq 250 kHz.

AM, Pulse, Burst, and I/Q baseband signals modulate the RF on the A13 Output. AM modulation originates on the A18 Reference, I/Q and Burst modulation originates on the A7 Baseband Generator, and Pulse modulation originates on the A23 Motherboard. AM modulation is routed directly to the A13 Output, I/Q modulation is routed through the A10 I/Q Multiplexer to the A13 Output, Pulse modulation and Burst modulation are routed through the A18 Reference to the A13 Output.

The RF signal leaving the A13 Output is then routed through an electronic attenuator. The attenuator includes a Reverse Power Protection (RPP) circuit to prevent damage to the synthesizer. Option UNB and Option 506 replace the electronic attenuator with a mechanical attenuator. Option 506 doesn't include an RPP circuit, but instead includes the A29 DC Blocking Capacitor which helps to protect the attenuator from dc power that may inadvertently be applied to the RF output connector.

Each signal generator's maximum frequency and power are dependent on the options that it contains.

A17 Synthesizer

The A17 Synthesizer is part of the *Frequency Synthesis Block*. It provides the A13 Output with its input signal. The RF is generated on the A17 Synthesizer by a VCO and this VCO is either divided or multiplied to achieve a final frequency which is amplified and filtered prior to it being routed to the A13 Output. A pre-level bias voltage generated by the A13 Output is fed back where it is used to bias a pin diode and control the amount of RF amplification.

A13 Output (Option 501, 502, 503, 504 or Option UNJ) or A13 Output (Option UNB)

The functions of the A13 Output include output power leveling, A17 Synthesizer pre-leveling, pulse/burst, I/Q and amplitude modulation (AM).

The filtered RF signal from the A17 Synthesizer is amplified and filtered by the A13 Output. After the first stage of amplification on the A13 Output, the RF signal is split with one path becoming the coherent carrier reference. The coherent carrier reference is free of any AM or Pulse/Burst modulation and is available at the COH Carrier output on the instrument's rear panel. The other path continues through the A13 Output. If I/Q modulation is enabled, the RF signal is routed through the I/Q modulator, otherwise it is bypassed. Depending on the output frequency, different bandpass filters are switched in to remove unwanted components from the RF signal. After filtering, the RF signal is split with a portion of the signal being detected and becoming the pre-level bias voltage used by the A17 Synthesizer.

Output power leveling is accomplished with an Automatic Leveling Control (ALC) loop. The ALC has two modes of operation: ALC open or ALC closed. For normal operation, the ALC loop is closed and the output power is leveled. For some modulation applications, the ALC is opened and an internal Power Search routine may be used to achieve amplitude accuracy.

When the ALC loop is closed, a portion of the RF output is detected and compared to the sum of the ALC reference voltage and the baseband AM. The difference is then applied to an integrator. The integrator output will ramp either positive or negative, based on the power of the input signal. If there is no difference between the detected voltage and the sum of both the ALC reference voltage and baseband AM, the integrator output will remain unchanged. The output voltage ramp is converted to a current and used to bias pin diodes in the ALC modulator. These pin diodes vary the amount of attenuation in the RF path and thus maintain leveled output power.

The A13 Output has two independent integrators to facilitate fast power switching. The feedback detector voltage is compared to one ALC reference voltage for one power level, while at the same time, a second independent ALC reference voltage is set up for the second power level. When the user changes from one power level to the other, the hardware switches between the two integrator circuits and their respective references. This function and its related parameters are available through the front panel **Alternate Amplitude** softkey and this softkey is only present when an electronic attenuator is installed.

Depending upon the application, the user may change the ALC bandwidth from normal to narrow. The defaults are normal if I/Q modulation is off and narrow if external I/Q modulation is on. The softkey is not available if internal I/Q modulation is selected.

When AM is enabled, the baseband signal originates on the A18 Reference. The signal enters the A13 Output as a Log AM signal. An Antilog circuit converts the Log AM back to Linear AM. As the baseband AM signal changes amplitude, it causes the ALC modulator bias to change proportionately. This is due to the AM signal being summed with the ALC Reference voltage prior to the integrator. Care must be taken to ensure that the ALC doesn't become unlevelled due to a combination of high carrier power and large modulation depth. The instrument's total output power equals the sum of the carrier power and the AM sidebands' power. If this sum is greater than the maximum output power rating, the ALC loop may become unlevelled.

The ALC loop also contains a pulse/burst modulator. The pulse signal originates on the A18 Reference and the burst signal originates on the A7 Baseband Generator. The pin diodes within the modulator are normally biased to provide minimum attenuation. When pulse/burst modulation is used, the pin diodes are biased off and on thus providing maximum or minimum attenuation. This causes the RF signal to pulse on and off. For narrow pulse widths, the ALC is opened. To maintain power level accuracy, a Power Search routine may be used through the front panel. The Power Search routine shuts down the modulation, momentarily closes the ALC loop, and levels. The ALC is then opened up and the modulation is turned back on.

The E4438C has an I/Q modulator located on the A13 Output and may be switched in or out of the RF path. Baseband modulation, for the I/Q modulator, is provided by the A10 I/Q Multiplexer. User-selectable lowpass filtering may be applied to the baseband I and Q signals. The user may also perform a front panel I/Q calibration. The calibration doesn't require any external stimulus and will minimize quadrature and gain errors. A portion of the I and Q signals are fed back to the A10 I/Q Multiplexer which minimize offset. When I/Q modulation is enabled, the pre-level bias for the A17 Synthesizer is provided by the I/Q modulator.

AT1 Electronic Attenuator or AT1 High-Power Mechanical Attenuator with A28 Reverse Power Protection

There are two different attenuator modules available. A standard instrument has a high-speed solid state 130 dB electronic attenuator. Option UNB and Option 506 have a 135 dB mechanical attenuator. The mechanical attenuator is standard hardware for Option 506. Both attenuators step in 5 dB increments. When the attenuator changes values, the new attenuation section is switched into the RF path prior to switching the unused attenuator section out. This prevents damage to sensitive devices under test due to high power being applied. Attenuation sections are switched into operation in a specific order to achieve the best input and output matching for each level of attenuation. The attenuator modules are field replaceable, but not field repairable.

The standard electronic attenuator has the RPP circuitry incorporated internally with the attenuator module circuitry. In contrast, the mechanical attenuator has the A28 Reverse Power Protection circuit as an external module that is attached to the attenuator. The RPP circuitry prevents instrument damage when power is mistakenly applied to the instrument's RF output. Operationally, the RPP circuitry opens an RF relay when 1 Watt of energy is sensed on the RF output. Repeated high levels of reverse power degrade the performance of the RPP or completely bypass the open RF relay. The RPP may be reset through front panel softkeys.

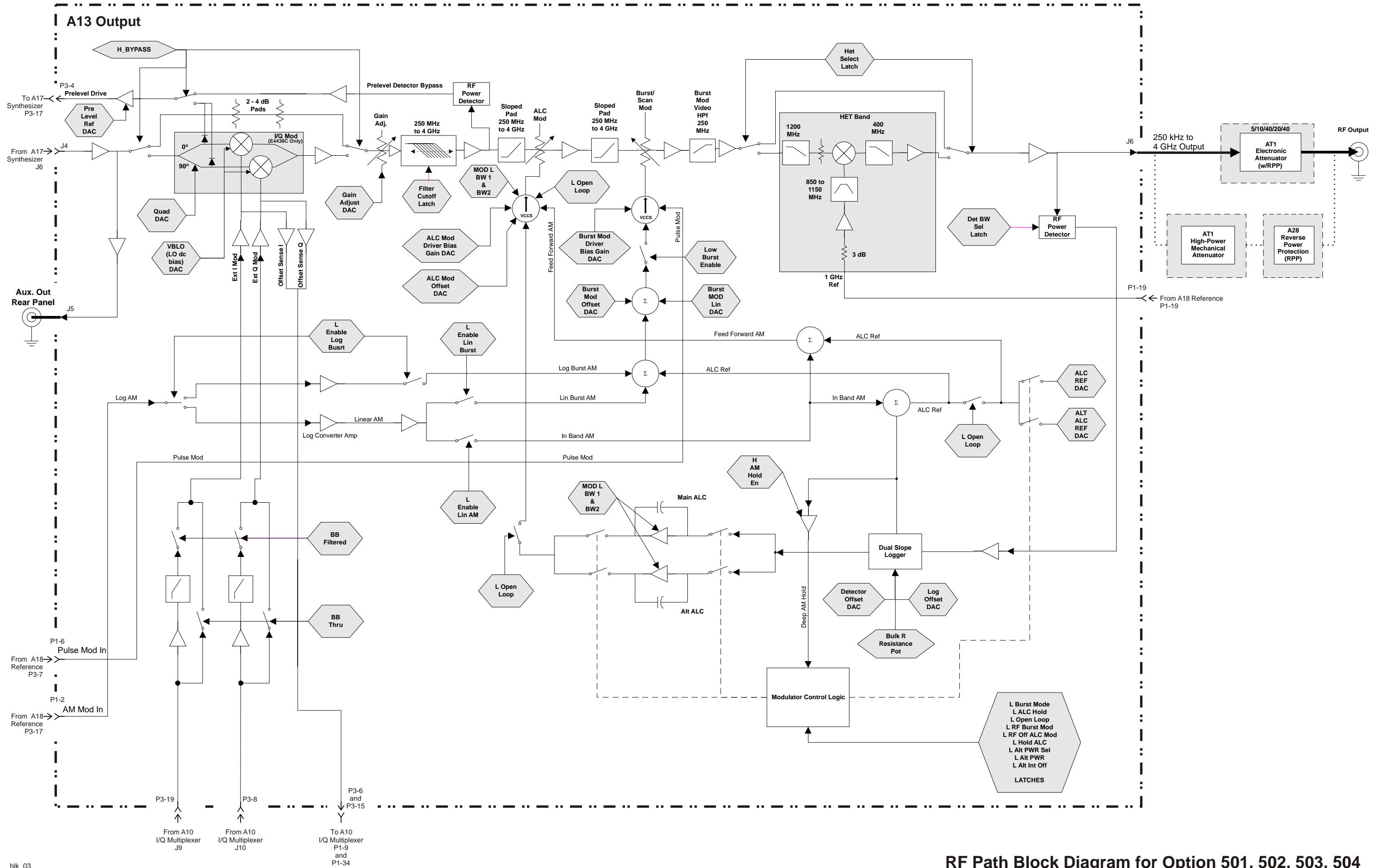

Overall Block Description for Option UNJ and Option 506

Overview

The objective of this overall block description is to provide a functional overview of the Agilent E4428C/38C ESG signal generator with Option UNJ and Option 506. Some of the functional blocks discussed are common to many types of instruments while others are more specific to signal generators.

- Common Functions:
 - Power Supply
 - CPU
 - Input/Output Interface
- Specific Signal Generator Functions:
 - Frequency Generation
 - Output Power Level Control
 - Modulation

A6 Power Supply

The main power supply converts line voltage (120 Vac or 240 Vac) to regulated dc voltages. Some of the required dc voltages are not directly provided by the main power supply and are generated by converting the main power supply voltages. Most of the conversions are performed on the A23 Motherboard, but a few are performed on individual assemblies.

A24 Line Module

The line voltage is connected to the power supply through the A24 Line Module. Line voltage selection isn't required because the A6 Power Supply automatically detects and adjusts to different line voltages. The power supply has an internal line fuse, but if the fuse opens, the power supply must be replaced; it is not field repairable.

A12 CPU

The A12 CPU controls all activities in the signal generator. It translates information entered from the front panel keys, LAN, GPIB, or Auxiliary Interface (RS-232) into machine level instructions and communicates these instructions on the internal buses. The A12 CPU also monitors critical circuits for unlevelled and unlocked conditions and reports these problems on the display.

Input/Output Interface

The Input/Output Interface is located on the front panel and includes the A1 Keyboard, the A2 Display, and the On/Off power switch. The user interface consists of the front panel keypad and the display softkeys. The current signal generator state is displayed on the A2 Display. Above the power switch, are amber and green Light Emitting Diodes (LED). When the amber LED is lit, it indicates that line voltage is present and that the signal generator is in standby mode. When the green LED is lit, it indicates that the signal generator is in the power-on mode.

Front Panel Hardkeys, Softkeys, and Keypad

Some front panel keys are referred to as hardkeys; these keys are dedicated to specific functions. Dedicated hardkeys are used to select the most commonly used features and control the display's contrast and intensity. Front panel keys along the display are referred to as softkeys and are used to select functions; these functions are displayed to the left of each softkey on the display. As softkeys are pressed, their displayed functionality is executed; some of these softkeys have lower-level menus

which are displayed when pressed. The front panel has a keypad that uses a row and column configuration. Pressing a key on this keypad makes a connection between a row and column. The row and column information is routed to the A12 CPU where it is interpreted and the appropriate action is taken.

A2 Display

A Liquid Crystal Display (LCD) provides information about the signal generator's settings and condition. The LCD requires a power supply, lighting, and data. The lighting, supplied from a light bulb on the A2DS1 Display Backlight is powered by the A4 Inverter. The A4 Inverter converts a dc voltage an ac voltage. Data is generated on the A12 CPU and routed to the LCD through the A3 Front Panel Auxilary Board.

A25 Rear Panel Board

The A24 Line Module, LAN, GPIB, and RS-232 connections are located on the A25 Rear Panel Board. On signal generators with Option 1EM, the A25 Rear Panel Board is replaced with the A26 Rear Panel LVDS Board (Option 1EM) and A27 Rear Panel SMB Board (Option 1EM).

RF Output Connector

The RF output connector is a female Type-N. Option 1EM routes the RF output to the signal generator's rear panel.

RF Path - Frequencies 250 kHz to 4 GHz (Option UNJ)

The output of a YIG oscillator is routed, through the A16 Frac-N, to the A13 Output which contains ALC circuitry to maintain power leveling. AM and Pulse modulation are also implemented on the A13 Output. The signal is further conditioned and routed through the optional AT1 Attenuator and to the front panel RF output connector.

For frequencies below 250 MHz, the A13 Output down converts the RF signal. To accomplish the down conversion, the A18 Reference provides a 1 GHz LO to a mixer on the A13 Output. The resultant IF out of the mixer is then routed to the AT1 Attenuator or to the front panel RF output connector.

RF Path - Frequencies > 4 GHz to ≤ 6 GHz (Option 506 Only)

The output of a YIG oscillator is routed to the A13 Output which contains ALC circuitry to maintain power leveling. AM and Pulse modulation are also implemented on the A13 Output. The signal is further conditioned and routed through the A14 Extended Frequency Output, to the optional AT1 Attenuator, and then to the front panel RF output connector.

For frequencies > 4 GHz and ≤ 6 GHz, the A22 Coupler couples off the YIG oscillator signal and routes it to the A14 Extended Frequency Output which contains similar circuitry to that of the A13 Output.

So, depending on the desired frequency, the RF path switches between the A13 Output and the A14 Extended Frequency Output before it is routed to the optional AT1 Attenuator, and then to the front panel RF output connector. The RF path is switched on the A14 Extended Frequency Output.

Frequency Control

Frequency accuracy and stability are established with the A18 Reference, A15 Sampler, A16 Frac-N, and the A12 CPU.

Frequency Generation

The YIG oscillator, on the A21 YTO Driver, generates frequencies from 4 GHz to 8 GHz. For frequencies from 250 MHz to 4 GHz, the YIG oscillator is tuned in the 4 to 8 GHz range and the output is divided by 2, 4, 8, or 16. If the desired frequency is below 250 MHz, an additional mixer is used. For frequencies > 4 GHz and ≤ 6 GHz (Option 506) the YIG frequency is not divided.

To change frequencies, the A12 CPU controls the A21 YTO Driver and coarse tunes the YIG with a voltage provided by the pre-tune DAC. The A15 Sampler compares the signal from the YIG to a reference signal and generates an error voltage proportional to the frequency error. This voltage is summed with the pre-tune DAC voltage and corrects (fine tunes) the YIG's

output frequency.

The reference signal is provided by the VCO on the A16 Frac-N that is phase-locked to a 10 MHz reference on the A18 Reference. The A15 Sampler down converts the YIG frequencies to make the comparison with the reference. The comparison is done by a phase detector, which generates an output voltage proportional to the difference in frequency/phase. This voltage tunes the YIG until there is no difference in frequency/phase.

Output Power Leveling/Automatic Leveling Control

Output power control circuitry consists of a detector, integrators, two ALC modulators, and other associated circuitry. This circuitry is commonly referred to as the Automatic Leveling Control (ALC) loop. A small portion of the RF signal is detected and converted to a dc voltage. In closed loop operation, a comparison is made between a reference voltage and the detected voltage. If the detected and reference voltage levels agree, the modulator drive current remains constant. If the detected and reference voltage levels do not agree, the modulator drive current changes causing the RF output power to increase or decrease until the reference and detected voltages agree. In open loop operation or ALC OFF mode, only the reference voltage is used to control the modulation drive current. The reference voltage is determined by the desired power setting and includes the stored calibration data used to compensate for any losses that occur after the detector. The reference voltage is generated on the A13 Output and A14 Extended Frequency Output by a DAC and is controlled by the A12 CPU.

Analog Modulation

An *Internal Modulation Source Function Generator*, located on the A23 Motherboard, is used to provide AM, FM, PM, and Pulse modulation capabilities. To improve phase modulation control, this function generator is tied to the 10 MHz reference signal from the A18 Reference. The function generator's signal is routed to the A18 Reference, which contains a multiplexer. The multiplexer is controlled through the front panel and may be used to select the modulation source. External modulation may be applied through the EXT 1 and EXT 2 front panel inputs. There is also a feature that allows internally generated signals to be routed to the LF Output on the front panel. AM and Pulse modulation signals are routed to the A13 Output and A14 Extended Frequency Output while FM and PM modulations are routed to the A16 Frac-N.

Digital Modulation (E4438C Only)

The A10 I/Q Multiplexer routes the front panel I/Q baseband signals to the A13 Output and A14 Extended Frequency Output so that they can be used to modulate the RF signal. The A10 I/Q Multiplexer also routes the front panel I/Q signals to the rear panel. Along with the original I/Q signal, an inverted I/Q signal is available at the rear panel.

If the signal generator contains an A7 Baseband Generator, it may provide the baseband I/Q signals; it also has the capability of burst modulation. The A10 I/Q Multiplexer may select which baseband signal to use and route the signal in the same manner as the external front panel I/Q signals.

The I/Q signals are simultaneously routed by the A10 I/Q Multiplexer to the A18 Reference so they may be used to modulate AM, FM, and PM.

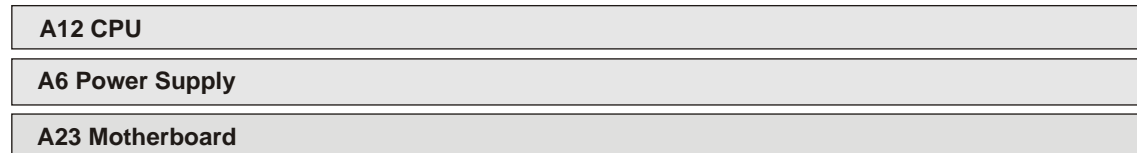
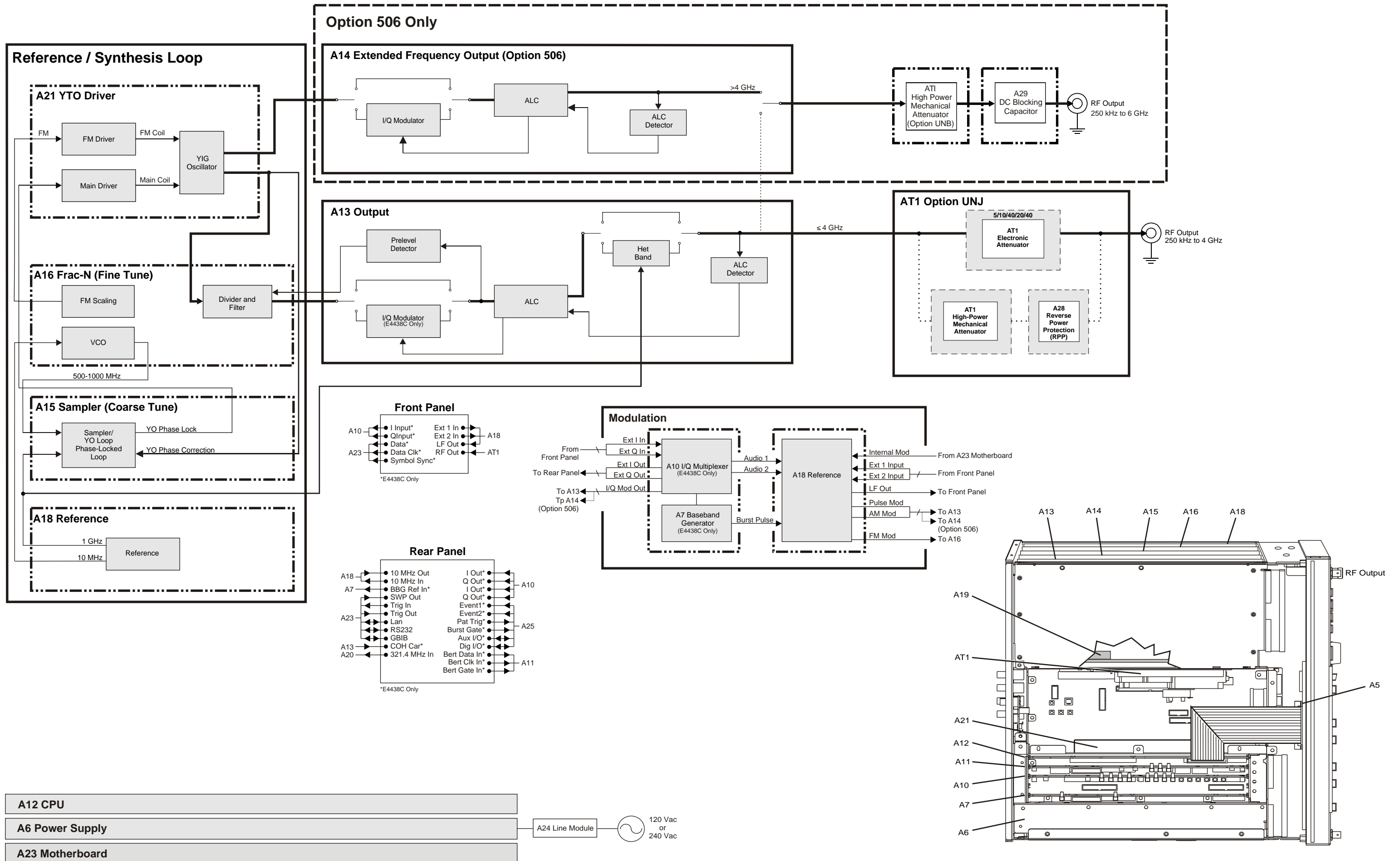

Overall Block Diagram for Option UNJ and Option 506

Frequency Synthesis Block Description for Option UNJ and Option 506

Overview

Frequency synthesis for Option UNJ and Option 506 signal generators is made from portions of the following:

- A18 Reference
- A15 Sampler
- A16 Frac-N
- A21 YTO Driver
- A13 Output (Option UNJ)
or A13 Output (Option UNB)
- A14 Extended Frequency Output
- A23 Motherboard

The Frequency Synthesis Block consists of the A18 Reference, A15 Sampler, A16 Frac-N, and the A21 YTO Driver. Frequency synthesis begins on the A18 Reference with a 10 MHz reference *Oven Controlled Xtal Oscillator* (OCXO). The OCXO may be phase-locked to an external reference or operate stand-alone. The 10 MHz OCXO phase locks a 1 GHz *Surface Transverse Wave* (STW) resonator on the A18 Reference. The frequency accuracy of the 10 MHz reference is translated to the final output frequency accuracy. The 10 MHz and 1 GHz signals are distributed throughout the signal generator. In this discussion, we will concentrate on the 10 MHz going to the A16 Frac-N and the 1 GHz going to the A15 Sampler. The 10 MHz is also routed to the *Internal Modulation Source Function Generator* located on the A23 Motherboard, and to the rear panel. The 1 GHz is also routed to the heterodyne circuit on the A13 Output.

Frequency generation is accomplished with a YIG Oscillator (YO) on the A21 YTO Driver. When the instrument's frequency is changed, a DAC on the A21 YTO Driver is used to coarse tune the YIG.

The 10 MHz reference is part of a Phase Lock Loop (PLL) on the A16 Frac-N. The PLL tunes a Voltage Controlled Oscillator (VCO), which is then routed to the A15 Sampler.

On the A15 Sampler, the 1 GHz from the A18 Reference is divided down and mixed to generate 750 MHz. It is then mixed with the VCO from the A16 Frac-N with the resulting IF being one input to a phase comparator. The other input to the phase comparator is derived from a portion of the YO signal being fed back to the A15 Sampler. The A15 Sampler down converts the YO signal to a Sampler IF. The Sampler IF is the other input to the phase comparator. The output of the phase comparator is integrated and routed to the A21 YTO Driver. The A21 YTO Driver sums the coarse tune DAC with the integrator signal from the A15 Sampler and uses the signal to fine tune the YO.

A18 Reference

Essential to frequency accuracy and low phase noise are clean and stable reference signals. The reference signals on the A18 Reference are a 10 MHz OCXO and a 1 GHz STW. To minimize frequency drift, the 10 MHz oscillator has an oven to maintain a constant crystal temperature. If the instrument has been without electrical power, a "Reference Oven Cold" warning is displayed when it is powered on. The warning message is controlled by a timer and should go out after five minutes of being connected to ac power. The 10 MHz OCXO may also be phase locked to an external 2, 5, or 10 MHz reference. The 10 MHz reference is also available at the signal generator's rear panel and may be used to phase lock other instruments in a system. The 10 MHz OCXO is routed to the A16 Frac-N and is part of a PLL to tune a VCO.

The 1 GHz STW is split with one leg being divided down to 10 MHz. This signal is then phase compared to the 10 MHz OCXO with the difference driving an integrator. The integrator tunes the 1 GHz STW ensuring both reference signals are phase locked together. The other leg of the 1 GHz signal is routed to the A15 Sampler and A13 Output.

A16 Frac-N

The A16 Frac-N is used to fine tune the YO on the A21 YTO Driver. Two proprietary application specific integrated circuits (ASIC), named Paren and Tesera, are used to tune a VCO on the A16 Frac-N. The VCO is capable of being tuned from 500 MHz to 1000 MHz. The VCO is routed to the A15 Sampler where it is down converted and compared to a sampled frequency of the YO.

The tuning of the VCO begins with a 10 MHz signal from the A18 Reference. The 10 MHz reference is divided down to 5 MHz to reduce fractional spurs in the phase detector. The 5 MHz reference is then phase compared to a divided down VCO output. The primary division of the VCO is performed within the Tesera pre scaler ASIC. The pre scaler divisor is provided by the Paren ASIC. The output of the phase detector is integrated and then used to tune the VCO.

The baseband FM and PM from the A18 Reference are added to the VCO on the A16 Frac-N. There are two different paths for the modulation to be added to the VCO which are dependent on the modulation rate. If the modulation rate is outside the VCO PLL bandwidth, the baseband signal is scaled and applied to the VCO. A portion of the baseband signal is also split off and routed to the A21 YTO Driver's FM coil. If the baseband rate is within the PLL bandwidth, the signal is scaled and sent to the Sigma-Delta Modulator for digitizing. The digitized signal is used by Paren and Tesera to change the VCO tuning and implements the FM.

A15 Sampler

A portion of the A21 YTO Driver's YO signal is split off and routed to the A15 Sampler. This signal is sampled and phase compared to a down converted VCO from the A16 Frac-N. The difference signal is integrated and sent back to the A21 YTO Driver's main coil to tune the YO.

The process begins with a 1 GHz signal from the A18 Reference. The signal is split with one leg being divided down to 250 MHz. This signal is used as an LO for a mixer. The RF to the mixer is the 1 GHz reference. The 750 MHz IF is split twice, which means that there are three 750 MHz reference signals being used on the A15 Sampler. For clarity, let us label these references as 750 MHz (A), 750 MHz (B), and 750 MHz (C). The 750 MHz (C) reference is multiplied by a variable fraction, which is less than one, to reduce the frequency. This signal is phase compared to a Mixer IF (14 to 150 MHz). The difference is integrated and used to tune a VCO (618 to 905 MHz) on the A15 Sampler.

The output of the VCO on the A15 Sampler is split with one leg being mixed with the 750 MHz (B) reference signal to produce the Mixer IF. The other leg of the VCO on the A15 Sampler is used as the LO for the sampler. The RF for the sampler is provided by the A21 YTO Driver's YO signal. The Sampler IF (30 to 70 MHz) is one input to a phase comparator. The other input to the phase comparator is the down converted VCO on the A16 Frac-N. Depending on the instrument mode of operation, the VCO on the A16 Frac-N has two independent paths for down conversion. Mode 1 optimizes phase noise for offsets < 10 kHz by dividing down the VCO on the A16 Frac-N. Mode 2 optimizes phase noise for offsets > 10 kHz, by mixing the VCO on the A16 Frac-N with the 750 MHz (A) reference. In either mode, the down converted signal is the other input to the phase converter. The output of the phase comparator is integrated and routed back to the A21 YTO Driver's main coil to tune the YO.

A21 YTO Driver

The operating frequency of the YO on the A21 YTO Driver is from 4 to 8 GHz. YO tuning is accomplished by varying the current through the main coil. This causes the coil's magnetic field to change, which tunes the YO resonant frequency. When the signal generator's frequency is changed, a coarse tune DAC voltage is converted to a current to bias the main coil. The YO output is split with a portion of the YO signal being fed back to the A15 Sampler. The other portion of the YO signal is routed through the A16 Frac-N to the A13 Output. For Option 506, the YO is coupled off of the A21 YTO Driver and routed to the A14 Extended Frequency Output. The A15 Sampler uses the YO signal to generate a fine tune voltage, which is routed back to the A21 YTO Driver. This voltage is summed with the coarse tune DAC voltage and converted to a current. The current is used to bias the main coil and fine tunes the YO. The YO is split on the A13 Output with a portion of it being routed to the rear panel as the coherent carrier (COH Carrier).

For high modulation rates, the baseband FM is routed from the A16 Frac-N to the A21 YTO Driver. The signal is scaled and then used to bias the FM coil and tune the YIG.

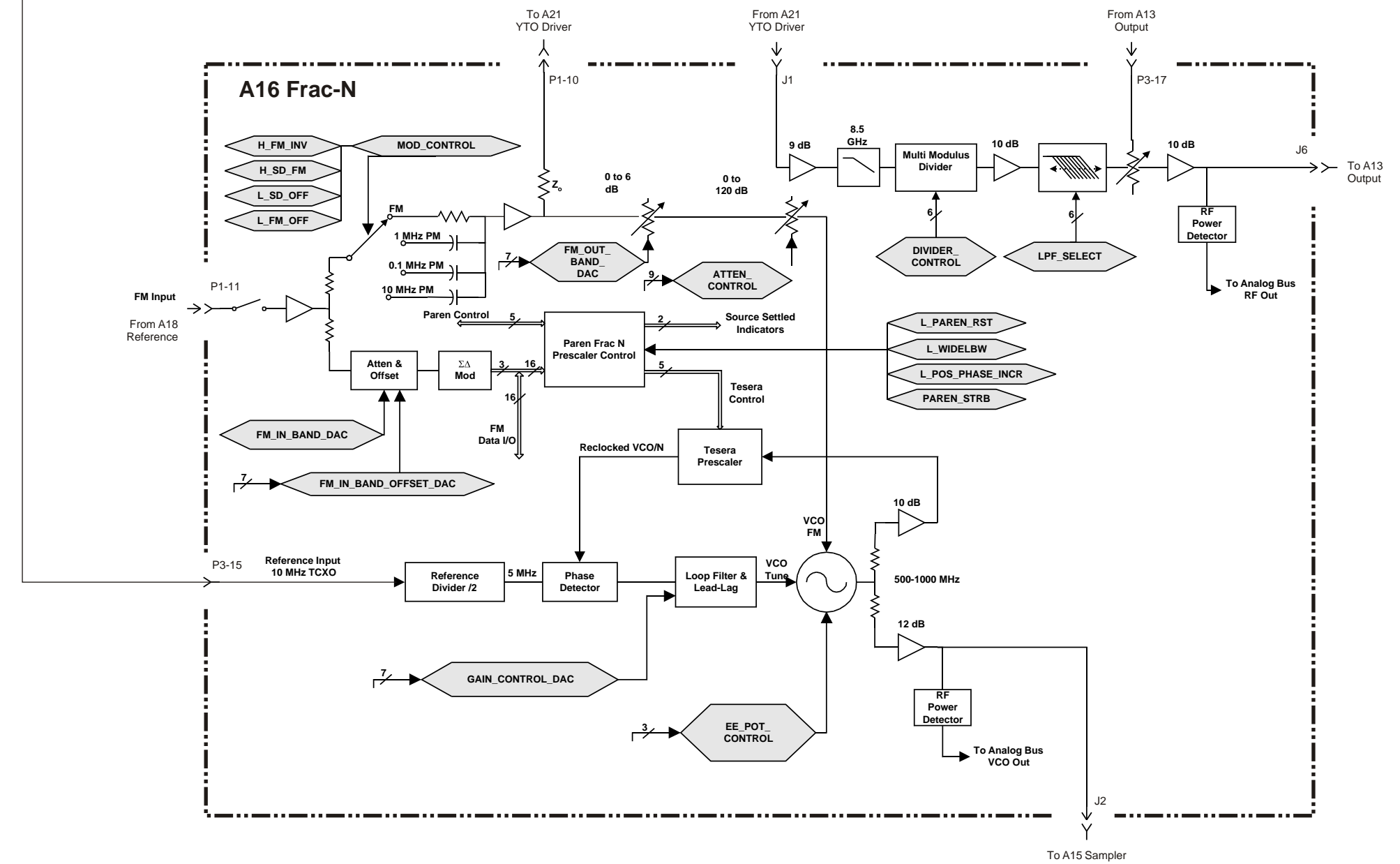
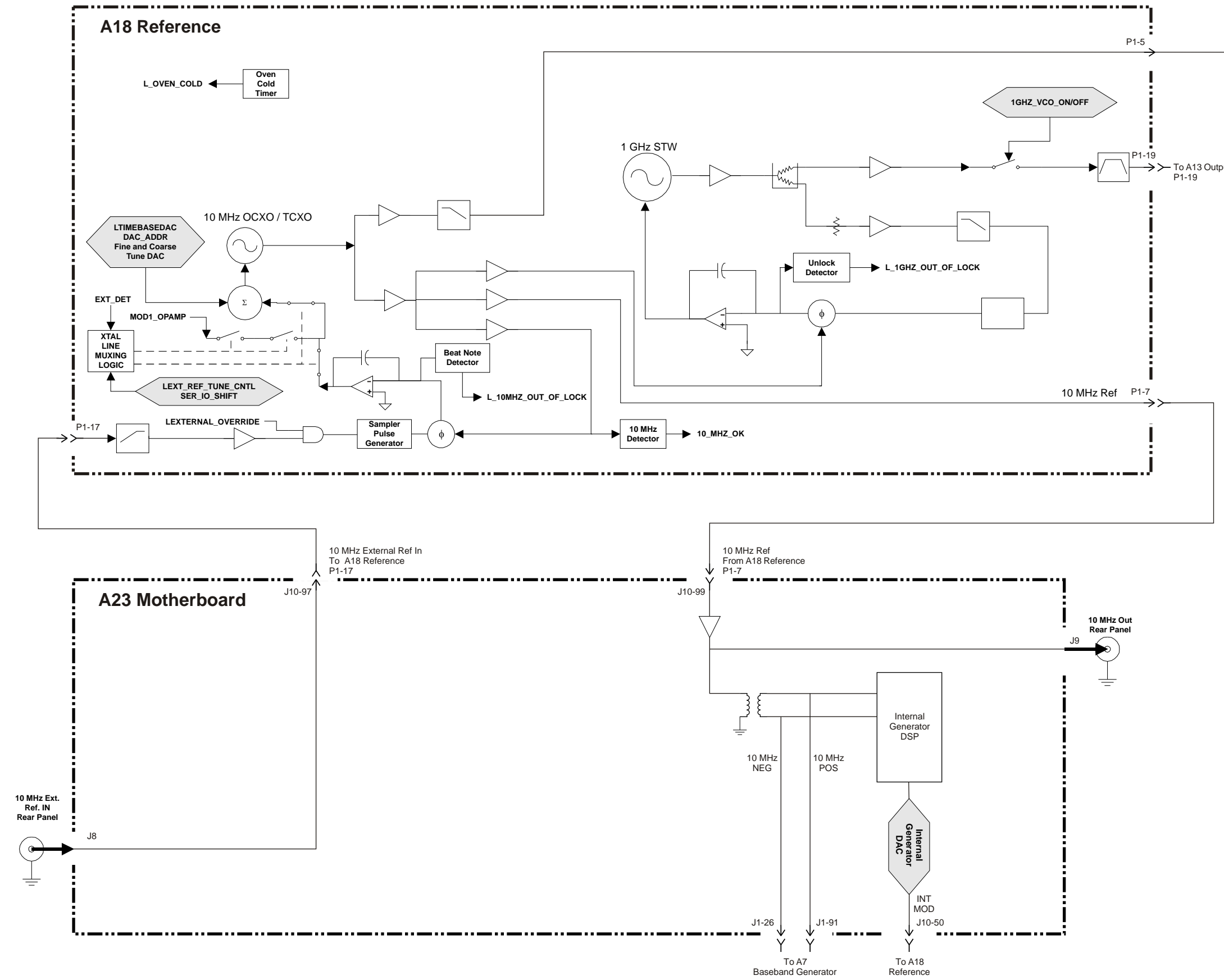

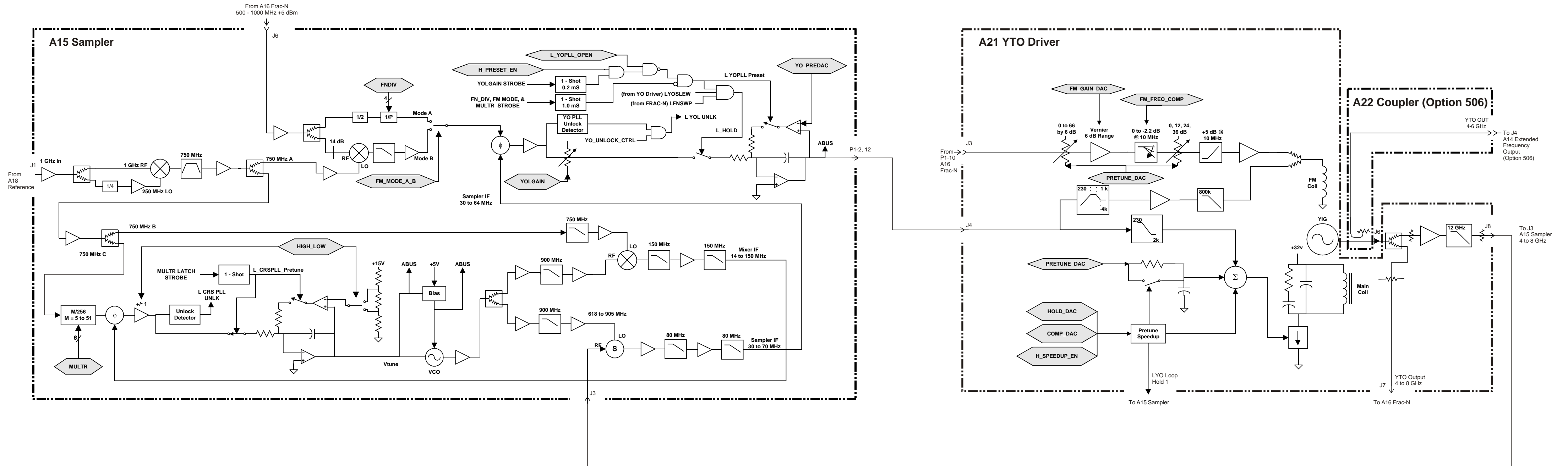

RF Path Block Description for Option UNJ or Option 506

Overview

The RF Path for signal generators with Option UNJ and Option 506 is made from portions of the following:

- A18 Reference
- A15 Sampler
- A16 Frac-N
- A21 YTO Driver
- A13 Output (Option UNJ)
or A13 Output (Option UNB)
- AT1 Electronic Attenuator with A28 Reverse Power Protection
or AT1 High-Power Mechanical Attenuator with A29 DC Blocking Capacitor

The RF Path consists of a portion of the A16 Frac-N, A21 YTO Driver, and the A13 Output. Frequency generation is accomplished with a YIG Oscillator (YO) on the A21 YTO Driver. The YO is tuned by the A16 Frac-N and the A15 Sampler. The YO signal is then routed through the A16 Frac-N to the A13 Output. The A13 Output contains the Automatic Level Control (ALC) loop for maintaining leveled power. For Option 506, an additional output board, A14 Extended Frequency Output, is added to control power for frequencies greater than 4 GHz to 6 GHz.

For RF frequencies below 250 MHz, a heterodyne mixer is switched into the RF path. The RF signal is mixed with a 1 GHz LO, provided by the A18 Reference, to produce the final 100 kHz to < 250 MHz output; specifications apply to frequencies \geq 250 kHz.

AM, Pulse/Burst, and I/Q baseband signals modulate the RF on the A13 Output. The AM and Pulse modulation originate on the A17 Reference board. While the I/Q and Burst modulation originate on the A7 Baseband Generator. The I/Q signal is routed via the A10 I/Q Multiplexer to the A13 Output. The Burst modulation signal is routed via the A18 Reference to the A13 Output.

The RF signal leaving the A13 Output is then routed through an electronic attenuator. The attenuator also includes a Reverse Power Protection (RPP) circuit to prevent damage to the signal generator. Option UNB replaces the electronic attenuator with a mechanical attenuator. Option 506 doesn't include an RPP circuit, but instead uses the A29 DC Blocking Capacitor.

The signal generator's maximum frequency and power are dependent on its options.

A21 YTO Driver

The operating frequency of the YO on the A21 YTO Driver is from 4 to 8 GHz. YO tuning is accomplished by varying the current through the main coil. This causes the coil's magnetic field to change, which tunes the YO resonant frequency. When FM is enabled, both the FM coil and main coil are used to tune the YO. The A15 Sampler and A16 Frac-N tune the main coil and FM coil respectively. For more details on the tuning of the YO, refer to [“Frequency Synthesis Block Description for Option UNJ and Option 506”](#) on page 1-135.

The YO output is then split and routed to the A16 Frac-N and the A15 Sampler. The A15 Sampler path is part of the Frequency Synthesis Block.

A16 Frac-N

The A16 Frac-N is part of the Frequency Synthesis Block and the RF path. Depending on the desired output frequency, the A16 Frac-N divides down the YO frequency. The A16 Frac-N also provides amplification and filtering for the YO signal prior to it being routed to the A13 Output.

A pre-level bias voltage generated by the A13 Output is fed back to the A16 Frac-N. The pre-level voltage is used to bias a pin

diode and control the amount of RF amplification on the A16 Frac-N.

A13 Output

The functions of the A13 Output include output power leveling, A16 Frac-N pre-leveling, pulse/burst, I/Q and amplitude modulation (AM).

The filtered RF signal from the A16 Frac-N is amplified and filtered by the A13 Output. After the first stage of amplification on the A13 Output, the RF signal is split with one path becoming the coherent carrier. The coherent carrier is free of any AM or Pulse/Burst modulation and is available to the user at the COH Carrier on the signal generator's rear panel. The other path continues through the A13 Output. If I/Q modulation is enabled, the RF signal is routed through the I/Q modulator, otherwise it is bypassed. Depending on the output frequency, different bandpass filters are switched in to remove unwanted components from the RF signal. After filtering, the RF signal is split with a portion of the signal being detected and becoming the pre-level bias voltage used by the A16 Frac-N.

Output power leveling is accomplished with an Automatic Leveling Control (ALC) loop. The ALC has two modes of operation: either ALC open or ALC closed. For normal operation, the ALC loop is closed and the output power is leveled. For some modulation applications, the ALC is opened and an internal Power Search routine may be used to achieve amplitude accuracy.

When the loop is closed, a portion of the RF output is detected and compared to the sum of the ALC reference voltage and baseband AM. The difference is then applied to an integrator. The integrator output will ramp either positive or negative, based on the power of the input signal. If there isn't any difference between the detected voltage and the sum of the ALC reference voltage and baseband AM, the integrator output will remain unchanged. The output voltage ramp is converted to a current and used to bias the pin diodes in the ALC modulator. The pin diodes vary the amount of attenuation in the RF path and thus maintain leveled output power.

The A13 Output has two independent integrators to facilitate fast power switching. The feedback detector voltage is compared to one ALC reference voltage for one power level. While at the same time, a second independent ALC reference voltage is set up for the second power level. When the user changes from one power level to the other, the hardware switches between the two integrator circuits and their respective references. This function and its related parameters are available through the front panel **Alternate Amplitude** softkey; this softkey is only present when an electronic attenuator is installed.

Depending upon the application, the user may change the ALC bandwidth from normal to narrow. The defaults are normal if I/Q modulation is off and narrow if external I/Q is on. The softkey is not available if internal I/Q is selected.

When AM is enabled, the baseband signal originates on the A18 Reference. The signal enters the A13 Output as a Log AM signal. An Antilog circuit converts the Log AM back to Linear AM. As the baseband AM signal changes amplitude, it causes the ALC modulator bias to change proportionately; this is due to the AM signal being summed with the ALC reference voltage prior to the integrator. Care must be taken to ensure the ALC doesn't become unlevelled due to a combination of high carrier power and large modulation depth. The signal generator's total output power equals the sum of the carrier power and the AM sideband power. If this sum is greater than the maximum output power rating, the ALC loop may become unlevelled.

The ALC loop also contains a pulse/burst modulator. The pulse signal originates on the A18 Reference and the burst signal originates on the A7 Baseband Generator. The pin diodes within the modulator are normally biased to provide minimum attenuation. When pulse/burst modulation is used, the pin diodes are biased off and on thus providing maximum or minimum attenuation. This causes the RF signal to pulse on and off. For narrow pulse widths, the ALC is opened. To maintain power level accuracy, a Power Search routine may be used through the front panel. The Power Search routine shuts down the modulation, momentarily closes the ALC loop, and levels. The ALC is then opened up and the modulation is turned back on.

The I/Q modulator is also located on the A13 Output and may be switched in or out of the RF path. Baseband modulation for the I/Q modulator is provided by the A10 I/Q Multiplexer. User selectable low pass filtering may be applied to the baseband I and Q signals. The user may also perform a front panel I/Q calibration. The calibration doesn't require any external stimulus and will minimize quadrature and gain errors. A portion of the I and Q signals are fed back to the A10 I/Q Multiplexer to minimize offset. When I/Q modulation is enabled, the pre-level bias for the A16 Frac-N is provided by the I/Q modulator.

A14 Extended Frequency Output

Option 506 extends the output frequency from 4 GHz to 6 GHz by adding a second output board. For CW and modulated signals 4 GHz and above, the A14 Extended Frequency Output is used. The board has the same modulation capability as the A13 Output and the baseband modulation signals are routed to both boards.

The A13 Output and A14 Extended Frequency Output are almost identical with the following differences:

- The YO signal on the A21 YTO Driver is coupled off and routed to the input of the A14 Extended Frequency Output.
- Having the YO bypass the A16 Frac-N, pre-leveling occurs on the A14 Extended Frequency Output.
- The pre-level circuit is prior to the I/Q modulator. (E4438C Only)
- Unlike the A13 Output, the I/Q modulator on the A14 Extended Frequency Output does not have a bypass path. The modulator is biased off for CW operation. (E4438C Only)
- The A14 Extended Frequency Output doesn't contain a heterodyne circuit; since this circuit is only used for frequencies below 250 MHz, the heterodyne circuit on the A13 Output is used.
- The A13 Output, 250 kHz to 4 GHz, is routed to the A14 Extended Frequency Output which contains a switch that routes either the A13 Output or the A14 Extended Frequency Output to the optional AT1 Attenuator and to the RF Output connector.

AT1 Electronic Attenuator with A28 Reverse Power Protection or AT1 High-Power Mechanical Attenuator with A29 DC Blocking Capacitor

There are two different attenuator modules available. A high-speed, solid state, 130 dB electronic attenuator is available for signal generators with Option 501, 502, 503, 504 and Option UNJ. Signal generators with Option UNB and Option 506 have a 135 dB mechanical attenuator. The mechanical attenuator is standard hardware for Option 506. Both attenuators step in 5 dB increments. When the attenuator changes values the new section is switched into the RF path prior to switching the unused attenuator section out. This prevents damage to sensitive devices under test due to high power being applied. Attenuation sections are switched into operation in a specific order to achieve the best input and output matching for each level of attenuation. The attenuator modules are field replaceable, but not field repairable.

The standard electronic attenuator has the RPP incorporated internally to the attenuator module circuitry. The mechanical attenuator has the RPP circuit as an external module with used with Option 501, 502, 503, 504 and Option UNJ signal generators; the RPP is externally attached to the mechanical attenuator. Signal generators with Option 506 do not use this same RPP because the frequency range of the RPP is limited to 4 GHz.

The RPP circuitry prevents instrument damage when power is mistakenly applied to the instrument's RF output. The RPP circuitry opens an RF relay when 1 Watt of energy is sensed on the RF output. Repeated high levels of reverse power degrade the performance of the RPP or completely bypass the open RF relay. The RPP may be reset through the front panel softkeys.

There is no RPP module available for Option 506, which covers the frequency range of 4 GHz to 6 GHz. Instead, an A29 DC Blocking Capacitor is used to block dc from damaging the AT1 High-Power Mechanical Attenuator.

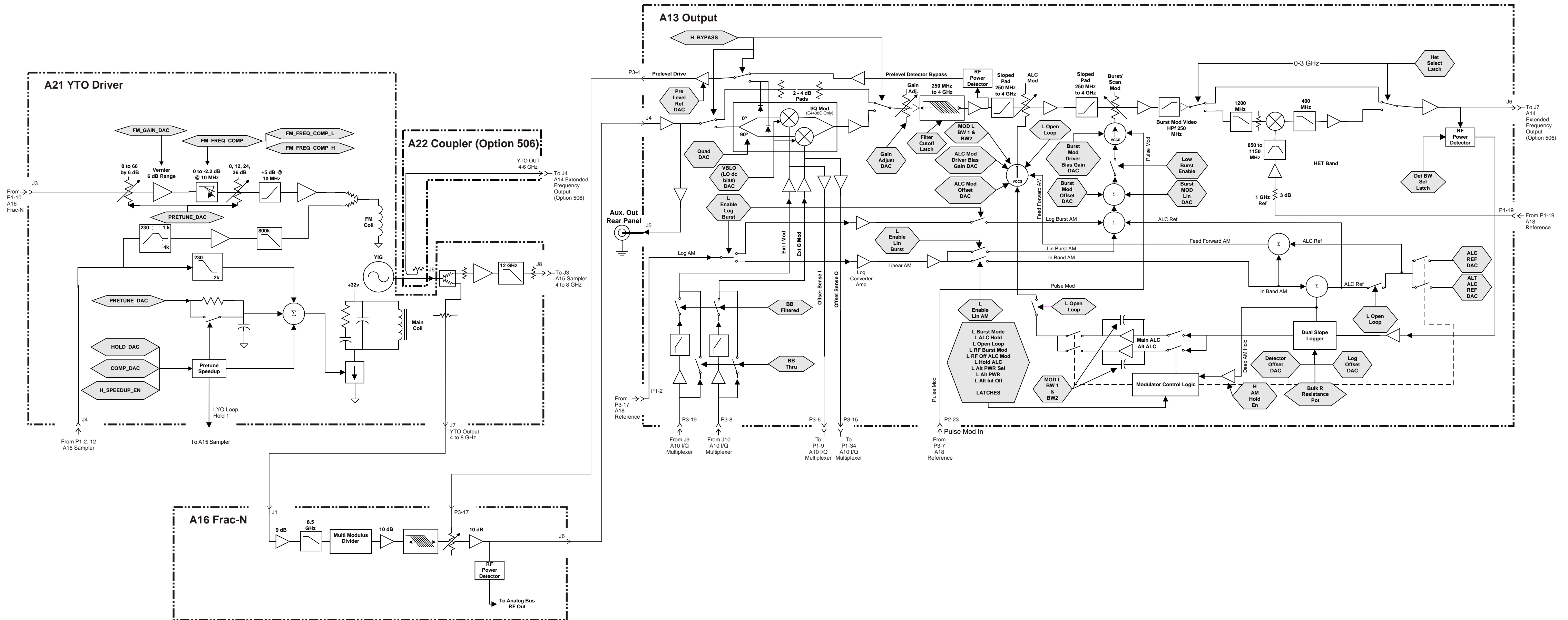

blk_09

A14 Extended Frequency Output (Option 506)

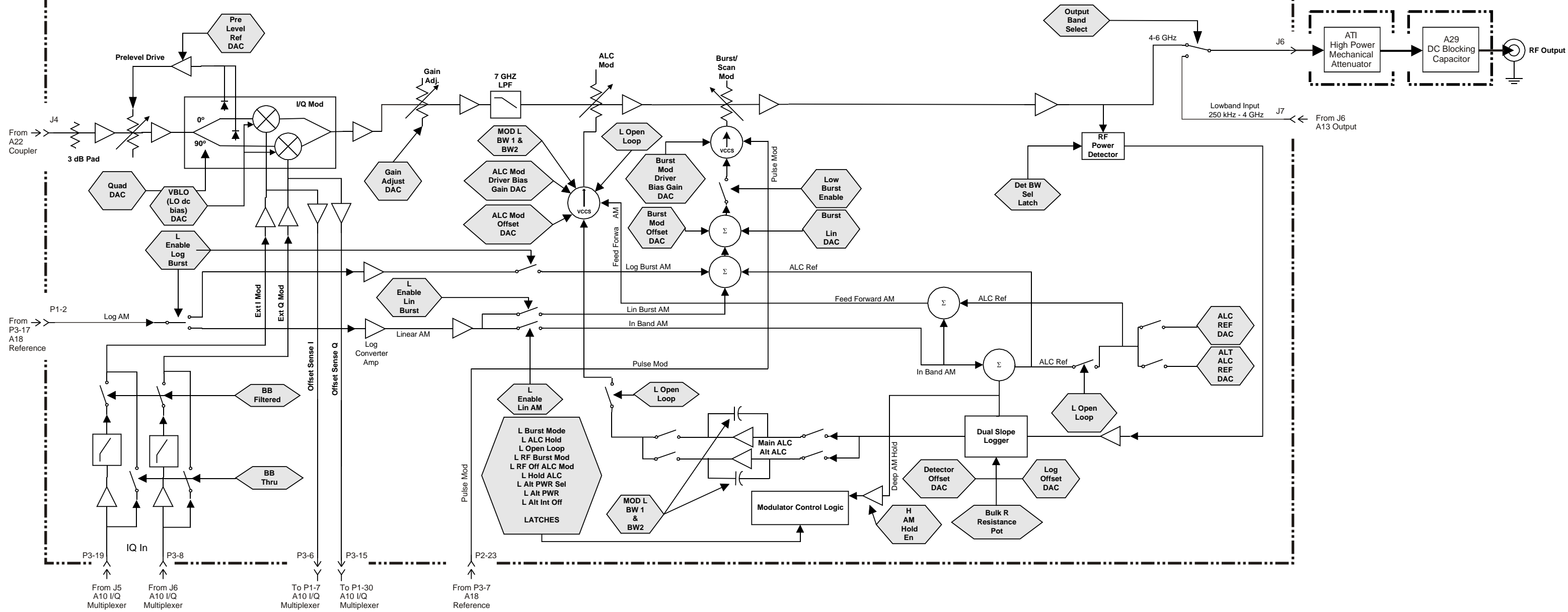

Analog Modulation Block Description for All Options

Overview

Analog modulation for all options of signal generators is made from portions of the following:

- A18 Reference
- A17 Synthesizer
- A10 I/Q Multiplexer (E4438C Only)
- A13 Output
- A7 Baseband Generator (E4438C Only)
- A23 Motherboard
- A15 Sampler
- A21 YTO Driver

The analog modulation block implements all analog modulations such as AM, FM, PM, and PULSE. The signal generator can be modulated using internal or external signals:

- Internal modulating signals are supplied by an *Internal Modulation Source Function Generator* located on the A23 Motherboard.
- External modulating signals can be ac or dc coupled through the EXT 1 and EXT 2 inputs.

The input impedance for the EXT 1 and EXT 2 inputs are 50 ohms nominal and are designed so that a +1 V_p or a -1 V_p produces the indicated deviation or depth. When ac modulating signals are used and ac coupled inputs are selected for FM/PM or AM, HI/LO annunciators will light if the peak input voltage differs by more than $\pm 3\%$ of 1 volt. This is accomplished using the over/under Mod detector.

I/Q and Burst signals from the *Digital Modulation* block can also be used as analog modulating signals. With the exception of Burst Pulse, all modulation signals can be utilized to drive external equipment using the LF OUTPUT port on the front panel.

Except for FM with PM, all modulation types can be simultaneously enabled. AM, FM, and PM can sum simultaneous inputs from any two sources (INT, EXT 1, EXT 2, AUDIO 1, AUDIO 2) allowing for composite modulating signals. Any given source (INT, EXT 1, EXT 2, AUDIO 1, AUDIO 2) can only be routed to one activated modulation type.

A10 I/Q Multiplexer (E4438C Only)

The A10 I/Q Multiplexer supplies the Audio 1 (I) and the Audio 2 (Q) signals to the A18 Reference. These signals are either from the A7 Baseband Generator or supplied externally through the EXT IQ-IN on the front panel. Once on the A18 Reference, these two signals can be switched to function as the AM, FM/PM, and PULSE modulating signals. In the wideband-AM mode, the user inputs the modulation signal through the "I" input on the front panel; this signal is routed through the A10 I/Q Multiplexer and then to the *I/Q Modulator* located on the A13 Output. Once there, the "I" input signal can directly modulate the main RF signal, thus avoiding the bandwidth limitation of the ALC. This method allows for faster AM rates of dc to 10 MHz (wideband-AM mode) compared to dc to 10 kHz (AM mode).

A7 Baseband Generator (E4438C Only)

The A7 Baseband Generator supplies the Burst Pulse signal to the A18 Reference. The Burst Pulse is used to drive the analog pulse modulation circuitry. This signal is not routed through the multiplexer circuit on the A18 Reference, but goes directly to the pulse drive output-summing node. Here, the Burst Pulse signal can be summed with the multiplexed pulse drive signals or be used alone to drive the pulse modulation circuitry located on the A13 Output.

A23 Motherboard

The Internal Modulation Source Function Generator is located on the A23 Motherboard. This circuit uses a Digital Signal Processor (DSP) chip to create waveforms digitally. This DSP chip uses the 10 MHz reference standard from the A18 Reference as its main clock. The digital output from the DSP chip is converted to analog by an output Digital-to-Analog Converter (DAC) and the analog waveform is then directed to the A18 Reference. The *Internal Modulation Source Function Generator* produces the following waveforms: Sine, Triangle, Square, Ramp, Noise, Dual Sine, Swept Sine, Pulse, and dc. The amplitude can be set from 0 volts up to +5 volts.

A18 Reference

The A18 Reference is the heart of the *Analog Modulation Block* and is responsible for routing all analog modulation drive input signals to the appropriate drive circuits. The *Internal Modulation Source Function Generator* (located on the A23 Motherboard), EXT 1 and EXT 2 (located on the front panel), as well as Audio 1 and Audio 2 (located on the A10 I/Q Multiplexer) input signals can all be individually switched to AM, FM, and Pulse modulation drive circuits.

The modulation drive outputs are:

- Frequency Modulation (FM)
 - On Option 501, 502, 503, 504 signal generators, this drive signal goes to the A17 Synthesizer and is used to modulate the VCO.
 - On Option UNJ and Option 506 signal generators, this drive signal goes to the A16 Frac-N and is used to modulate the Frac-N VCO.

It is also routed to the YO DRIVER and used to modulate the FM coil of the YIG; the YIG is located on the A21 YTO Driver.

- Phase Modulation (PM)

PM uses the same signal flow as FM, but is filtered differently.

- PULSE Modulation

This drive signal is directed to the A13 Output and is used to drive the Scan/Burst modulator, which in turn, pulse-modulates the main RF signal.

- Amplitude Modulation (AM)

This drive signal is directed to the A13 Output and is used to drive the Scan/Burst modulator and the ALC modulators, which in turn, amplitude modulate the main RF signal.

- LFO out drive signal

This drive signal is directed to the front panel and is used to modulate external equipment.

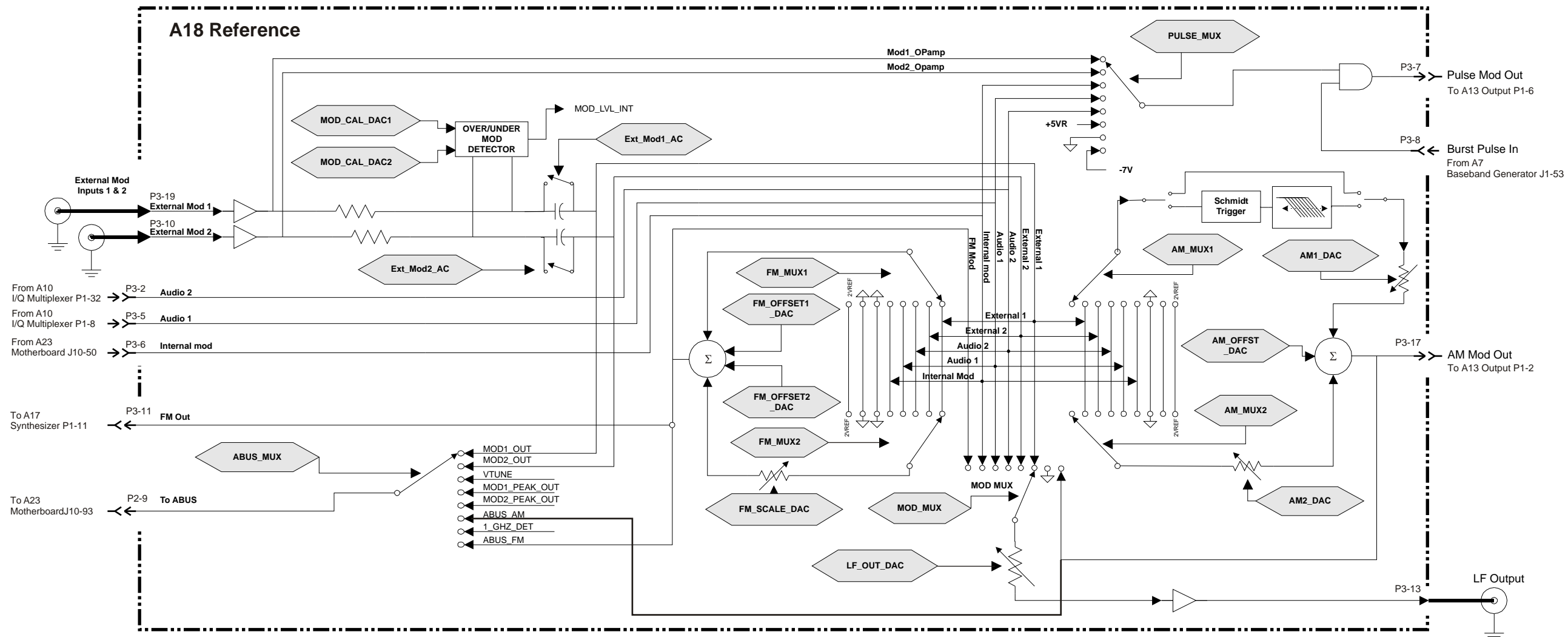
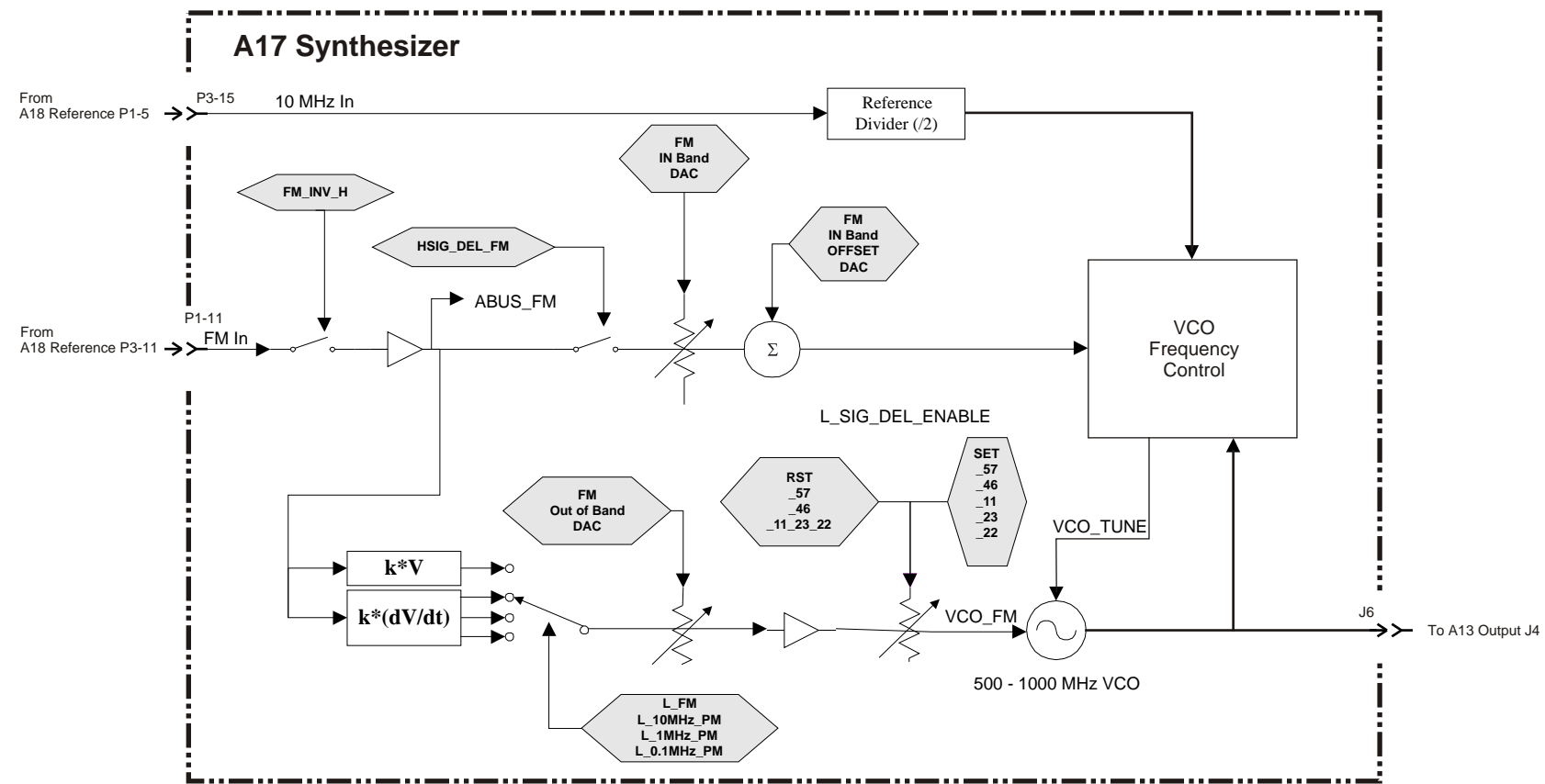

Digital Modulation Block Description for All E4438C Options

Overview

Digital modulation for all options of signal generators is made from portions of two major assemblies:

- A7 Baseband Generator
- A10 I/Q Multiplexer

Together, these assemblies are responsible for generating and routing the baseband signals to the I/Q modulator located on the A13 Output. The A7 Baseband Generator consists of data generation, burst control, and symbol building circuitry. The output section of the A7 Baseband Generator consists of two 16-bit DACs: one for the I signal and one for the Q signal. The data produced from these I/Q signals is converted to analog, amplified, and filtered before being routed to the A10 I/Q Multiplexer. The I/Q signals are routed from the A10 I/Q Multiplexer to the I/Q modulator located on the A13 Output. These I/Q signals are used to modulate the main RF signal that represents one of the many “Digital Modulation/Communications Standard” formats such as TDMA, CDMA, W-CDMA, GSM, NADC and others.

A7 Baseband Generator

The A7 Baseband Generator can be used as a *Dual Arbitrary Waveform Generator*, a *Real Time I/Q Baseband Generator*, or a *Noise Generator*. Waveform personalities can be purchased in order to generate standard formats. Customer supplied waveforms can also be downloaded into the waveform memory to generate customized formats.

The I/Q bandwidth is 80 MHz for internally generated I/Q signals and 160 MHz for externally generated I/Q signals. The A7 Baseband Generator can generate symbol rates of up to 6.25 Msymbol/sec.

- A7 Baseband Generator (Option 001/601) has 8 Msamples of waveform memory
- A7 Baseband Generator (Option 002) has 32 Msamples of waveform memory
- A7 Baseband Generator (Option 602) has 64 Msamples of waveform memory

Data is sequenced from waveform memory by the Field Programmable Gate Array block (A1-FPGA), passed on to the format builder block (A2-FPGA/Modulator/Filter), and finally to the output section. I and Q DACs at the output convert the digital waveform data to analog. The I and Q output DACs are driven by a sample clock generated by an on-board VCO. The VCO has a frequency range of 200 to 400 MHz. The 10 MHz reference signal from the A18 Reference is supplied and used to phase-lock the sample clock signal of the DACs to the A18 Reference; an external 10 MHz reference signal could also be used.

The Burst Pulse signal from the A7 Baseband Generator goes to the analog modulation block on the A18 Reference (which is part of the *Frequency Synthesis Block*) and is used to drive the pulse modulator located on the A13 Output. The Burst Pulse signal is used by the digital modulation formats to synchronize the main RF path and ensure maximum on/off level ratio.

The I and Q output signals are the main signals out of the A7 Baseband Generator. They are also the digital modulating signals that go to the A10 I/Q Multiplexer which are then routed to the I/Q modulator on the A13 Output.

A10 I/Q Multiplexer

The A10 I/Q Multiplexer receives I/Q input signals from the A7 Baseband Generator, external I/Q inputs signals from the front panel, and an I/Q sense feedback signal from the I/Q modulator on the A13 Output. The A10 I/Q Multiplexer inverts and routes the I and Q signals to the rear panel where these signals can then be used to modulate external equipment. Both inverted and non-inverted signals are available at the rear panel. The A10 I/Q Multiplexer routes the main internal I and Q modulating signal into the I/Q modulator on the A13 Output which is used to modulate the main RF output. These main internal I and Q modulating signals can be either from the A7 Baseband Generator or supplied through the external I/Q inputs.

The A10 I/Q Multiplexer has two identical paths in which to switch the incoming I/Q signals. Each path has individual gain control and can be switched to a summing node. The output of the summing node can be switched to the EXT outputs and in addition continues on through more gain control circuitry and finally out to the A13 Output. I/Q signals are supplied

simultaneously to the A13 Output and to both the inverted and non-inverted external jacks.

The I and Q inputs are 16-bit data generated in the A7 Baseband Generator either by a waveform personality or by downloading externally. This data is converted to analog, filtered by the I and Q DACs, filters on the A7 Baseband Generator, and then goes to the A10 I/Q Multiplexer.

The user, through the front panel, supplies the EXT IN I and EXT IN Q signals. These signals enter the A10 I/Q Multiplexer and can either be switched into a 50 or 600 ohm input impedance.

An internal calibration source supplies proper input levels in order to perform independent self tests. This allows the firmware to check the A10 I/Q Multiplexer board by setting known levels and reading the various nodes without actually needing an I/Q signal.

An Offset Sense signal comes in from the I/Q modulator on the A13 Output and is used to adjust for offsets between the I and Q signals. The Offset Sense signal is compared to the I/Q signal output and the result is used to control the amplitude; the feedback signal minimizes quadrature and gain errors.

The A10 I/Q Multiplexer also routes the Audio 1 and Audio 2 signals over to the *Analog Modulation Block*, located on the A18 Reference, which enables the I (Audio 1) and Q (Audio 2) signals to be used as analog modulation signals. These signals originate from either the I/Q signals supplied by the A7 Baseband Generator or from the External I/Q inputs as selected by the A10 I/Q Multiplexer.

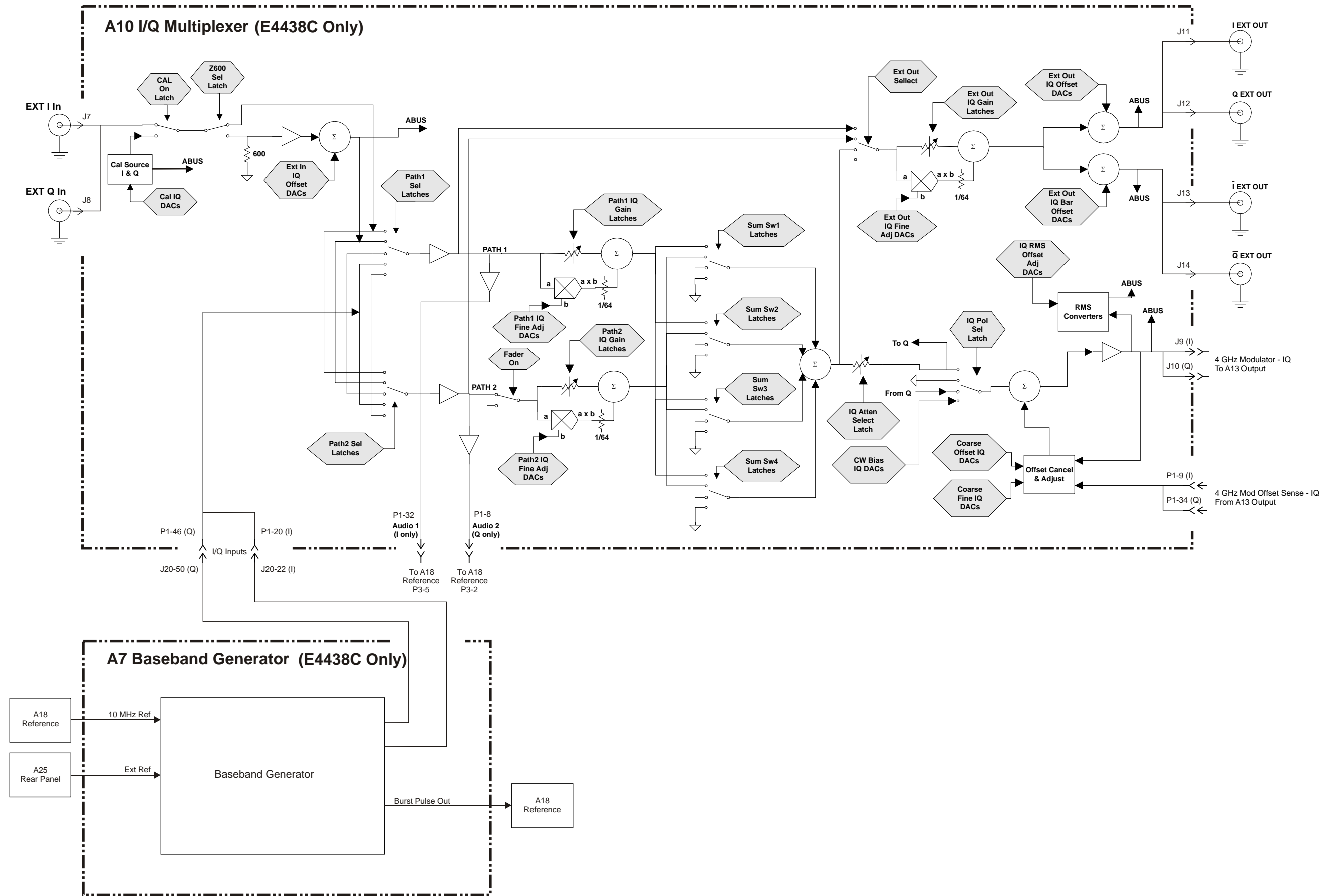

2 **Replaceable Parts**

Ordering Information

To order a part, do the following:

1. Determine the part number.
2. Determine the quantity required.
3. Mail this information to the nearest Agilent Technologies office or, in the U.S., call the hot-line number listed in the following section.

To order a part not listed in the replaceable parts lists, mail the following information to the nearest Agilent Technologies office or, in the United States, call the hot-line number listed in the following section.

- the instrument model number
- the serial number and options, if any (see rear panel)
- a description of the part
- a description of the part's function
- the quantity required

Order Parts Fast

When you have gathered the information required to place an order, go to the Agilent Technologies Technical Support website:
<http://www.agilent.com/find/techsupport>

Save Money with Rebuilt-Exchange Assemblies

Under the rebuilt-exchange assembly program, certain factory-repaired and tested assemblies are available on a trade-in basis. These assemblies cost less than a new assembly and meet all factory specifications required of a new assembly.

The defective assembly must be returned for credit under the terms of the rebuilt-exchange assembly program. The figure below illustrates the assembly exchange procedure in flowchart format.

Figure 2-1

Assembly Exchange Procedure

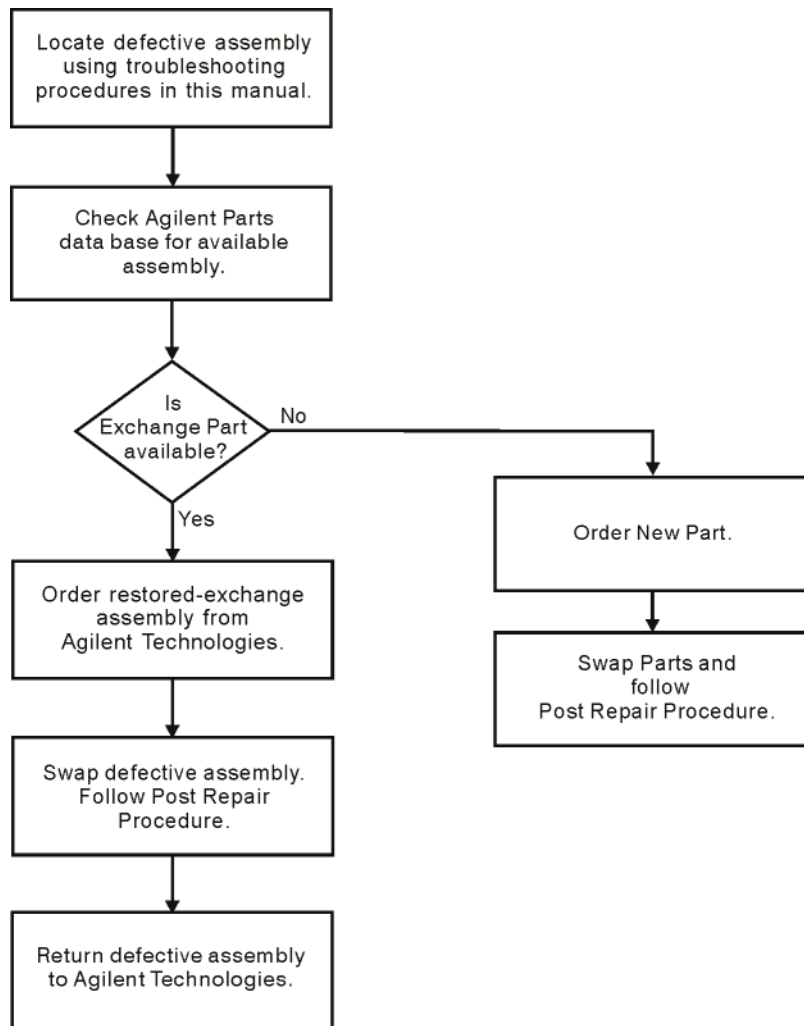

sk770a

Shipping a Defective Assembly Back to Agilent Technologies

1. When you receive the rebuilt assembly, be careful not to damage the box in which it was shipped. You will use that box to return the defective assembly. The box you receive should contain the following:
 - the rebuilt assembly
 - an exchange assembly failure report
 - a return address label
2. Complete the failure report.
3. Place the failure report and the defective assembly in the box. Be sure to remove the enclosed return address label.
4. Seal the box with tape.

If you are inside the United States, stick the pre-printed return address label over the label that is already on the box and return the box to Agilent Technologies. (Agilent Technologies pays postage on boxes mailed within the United States.)

If you are outside the United States, do not use the return address label; instead, address the box to the nearest Agilent Technologies sales and service office.

Frequency, Hardware, and Personality Options

This section lists the options available with the Agilent E4428C/38C ESG Signal Generators.

Frequency Options	
501	250 kHz to 1 GHz frequency range (E4438C Only)
502	250 kHz to 2 GHz frequency range (E4438C Only)
503	250 kHz to 3 GHz frequency range
504	250 kHz to 4 GHz frequency range (E4438C Only)
506	250 kHz to 6 GHz frequency range (Requires Option UNJ)

Hardware Options	
UNB	High output power with mechanical attenuator
UNJ	Enhanced phase noise performance (includes high stability timebase, Option 1E5)
UN7	Internal bit-error-rate analyzer
1E5	High stability timebase
1EM	Moves all front panel connectors to rear panel
001/601	Internal baseband generator with 8 Mega sample memory (E4438C Only)
002	Internal baseband generator with 32 Mega sample memory (E4438C Only)
003	Enables ESG digital output connectivity with N5102A (Option 601 or 602 required — E4438C Only)
005	10 GB hard drive (Option 001/601 or 002/602 required — E4438C Only)
300	GSM/EDGE basestation loopback BER test capability (Requires Options UN7, 001/601 or 002/602, and 402 — E4438C Only)
602	Internal baseband generator with 64 Mega sample memory (E4438C Only)

Signal Generator Personalities	
400	3GPP W-CDMA-FDD personalities (E4438C Only)
401	cdma2000 and IS95A personalities (E4438C Only)
402	TDMA personalities (includes GSM, EDGE, NADC, and others — E4438C Only)
403	Calibrated noise personalities (E4438C Only)
409	Real-Time GPS (Option 001/601 or 002/602 required — E4438C Only)
416	Enhanced observed time difference (E-OTD, Option 001/601/ or 002/602 and 402 required — E4438C Only)

Frequency, Hardware, and Personality Options

Software Personalities	
404	cdma2000-1xEV-DO Signal Studio personality (E4438C Only)
406	Bluetooth Signal Studio personality (E4438C Only)
417	Wireless LAN (802.11) Signal Studio personality

Assemblies and Hardware Options

Assembly	Option 501, 502, 503, 504 and Option 300	Option UNJ	Option 506
Front Panel Assembly	E4400-60522	E4400-60522	E4400-60522
A1 Keyboard page 2-19	E4400-60502	E4400-60502	E4400-60502
A2 Display page 2-19	2090-0375	2090-0375	2090-0375
A2DS1 Display Backlight page 2-19	1513-5204	1513-5204	1513-5204
A3 Front Panel Auxiliary Board page 2-19	E4400-60503	E4400-60503	E4400-60503
A4 Inverter page 2-19	0950-3757	0950-3757	0950-3757
A5 Hard Drive (E4438C Only) page 2-19	E4400-60253	E4400-60253	E4400-60253
A6 Power Supply page 2-10	0950-5037	0950-5037	0950-5037
Slot 1^a A7 Baseband Generator (Option 001 — E4438C Only) page 2-10 or A7 Baseband Generator (Option 002 — E4438C Only) page 2-10	E4400-60757	E4400-60757	E4400-60757
	E4400-60758	E4400-60758	E4400-60758
Slot 1^a (for instruments with serial prefixes <US4426/MY4426) A7 Baseband Generator (Option 601 - E4438C only) page 2-10 A7 Baseband Generator (Option 602 — E4438C Only) page 2-10	E4400-60759	E4400-60759	E4400-60759
	E4400-60760	E4400-60760	E4400-60760
Slot 1^a (for instruments with serial prefixes ≥US4426/MY4426) A7 Baseband Generator (Option 601/602 — E4438C Only) page 2-10	E4400-60761 ^b	E4400-60761 ^b	E4400-60761 ^b
Slot 2^a A9 Digital Demodulator (E4438C Only) page 2-10	E4400-60510	N/A	N/A
Slot 3^a A10 I/Q Multiplexer (E4438C Only) page 2-10	E8251-60063	E8251-60063	E8251-60063
Slot 4^a A11 Internal Bit Error Rate Analyzer (E4438C Only) ^c page 2-10	E4400-60519	E4400-60519	E4400-60519
Slot 5^a A12 CPU page 2-17	E4400-60500	E4400-60500	E4400-60500
Side-SLOT 1^d (for instruments with serial prefixes <US4528/MY4528) A13 Output (E4428C Only) page 2-17	E4400-60659	E4400-60659	E4400-60659 used with Side-SLOT 2

Assemblies and Hardware Options

Assembly	Option 501, 502, 503, 504 and Option 300	Option UNJ	Option 506
(for instruments with serial prefixes \geq US4528/MY4528) A13 Ouput (E4428C Only) page 2-17	E4400-60841	E4400-60841	E4400-60841 used with Side-SLOT 2
or A13 Output (E4438C Only)	E4400-60659	E4400-60659	E4400-60659 used with Side-SLOT 2
Side-SLOT 2 A14 Extended Frequency Output ^e page 2-17	N/A	N/A	E4400-60755
Side-SLOT 3 A15 Sampler page 2-17	N/A	E8251-60043	E8251-60043
Side-SLOT 4 A16 Frac-N page 2-17	N/A	E8251-60044	E8251-60044
or A17 Synthesizer page 2-17	E4400-60520	N/A	N/A
Side-SLOT 5 A18 Reference page 2-17	E4400-60512	E4423-60500	E4423-60500
or A18 Reference (Option 501, 502, 503, 504 with Option 1E5) page 2-17	E4400-60513	N/A	N/A
A19 Daughterboard page 2-17	E4400-60719	E4400-60719	E4400-60719
A20 Downconverter (E4438C Only) page 2-10	E4400-60544	N/A	N/A
A21 YTO Driver page 2-10	N/A	E4423-60510	E4423-60510
A22 Coupler page 2-10	N/A	N/A	0955-0098
A23 Motherboard page 2-10	E4400-60504	E4400-60504	E4400-60504
A23BT1 Battery page 2-23	1420-0356	1420-0356	1420-0356
(for instruments with serial prefixes <US4907/MY4907) A24 Line Module page 2-21	E4400-60537	E4400-60537	E4400-60537
(for instruments with serial prefixes \geq US4907/MY4907) A24 Line Module page 2-21	E4400-60766	E4400-60766	E4400-60766
A25 Rear Panel Board (E4438C Only) page 2-21	E4400-60655	E4400-60655	E4400-60655
or A26 Rear Panel LVDS Board (Option 1EM — E4438C Only) and A27 Rear Panel SMB Board (Option 1EM — E4438C Only) page 2-21	E4400-60524 E4400-60525	E4400-60524 E4400-60525	E4400-60524 E4400-60525
AT1 Electronic Attenuator page 2-10	E4400-60909	E4400-60909	N/A
AT1 High-Power Mechanical Attenuator ^f page 2-10	33322-60020 used with A28	33322-60020 used with A28	33322-60020 used with A29

Assembly	Option 501, 502, 503, 504 and Option 300	Option UNJ	Option 506
A28 Reverse Power Protection page 2-10	08648-60025	08648-60025	N/A
A29 DC Blocking Capacitor	N/A	N/A	0955-1131
B1 Power Supply Fan page 2-10	3160-4133	3160-4133	3160-4133
B2 Small Fan page 2-10	3160-4135	3160-4135	3160-4135
B3 Daughterboard/Card Cage Fan page 2-10	3160-4133	3160-4133	3160-4133
RF Output Connector page 2-19	E4400-60536	E4400-60536	E4400-60536

- a. Slot numbers one through five (where one is on the left) refer to the position of an assembly in the top card-cage of the signal generator when viewed from the top.
- b. Firmware C.04.54 or greater is required.
- c. A11 Internal Bit Error Rate Analyzer (Option UN7) is used with the A9 Digital Demodulator and A20 Downconverter for GSM/EDGE basestation loopback BER test capability (it also requires Option 001/601 or 002/602 and Option 402).
- d. Side-SLOT numbers one through five (where one is on top) refer to the position of an assembly in the right-hand side card-cage of the signal generator.
- e. Firmware C.04.60 or greater is required.
- f. AT1 High-Power Mechanical Attenuator (Option UNB) is used together with either an A28 Reverse Power Protection or with an A29 DC Blocking Capacitor.

Assemblies from a Top View

Refer to Figure 2-2 thru Figure 2-7.

Assembly	Option 501, 502, 503, 504 and Option 300	Option UNJ	Option 506
A6 Power Supply	0950-5037	0950-5037	0950-5037
Slot 1 A7 Baseband Generator (Option 001 — E4438C Only) or A7 Baseband Generator (Option 002 — E4438C Only)	E4400-60757 E4400-60758	E4400-60757 E4400-60758	E4400-60757 E4400-60758
Slot 1 (for instruments with serial prefixes <US4426/MY4426) A7 Baseband Generator (Option 601 — E4438C Only) or A7 Baseband Generator (Option 602 — E4438C Only)	E4400-60759 E4400-60760	E4400-60759 E4400-60760	E4400-60759 E4400-60760
Slot 1 (for instruments with serial prefixes ≥US4426/MY4426) A7 Baseband Generator (Option 601/602 — E4438C Only)	E4400-60761	E4400-60761	E4400-60761
Slot 2 A9 Digital Demodulator (E4438C Only)	E4400-60510	N/A	N/A
Slot 3 A10 I/Q Multiplexer (E4438C Only) or A10 I/Q Multiplexer (E4438C Only)	E4400-60191 N/A	E4400-60191 N/A	N/A E8251-60063
Slot 4 A11 Internal Bit Error Rate Analyzer (E4438C Only)	E4400-60519	E4400-60519	E4400-60519
Slot 5 A12 CPU	E4400-60500	E4400-60500	E4400-60500
A20 Downconverter (E4438C Only)	E4400-60544	N/A	N/A
A21 YTO Driver	N/A	E4423-60510	E4423-60510
A22 Coupler	N/A	N/A	0955-0098
A23 Motherboard	E4400-60504	E4400-60504	E4400-60504
AT1 Electronic Attenuator	E4400-60515	E4400-60515	N/A
AT1 High-Power Mechanical Attenuator ^a	33322-60020 used with A28	33322-60020 used with A28	33322-60020 used with A29
A28 Reverse Power Protection	08648-60025	08648-60025	N/A
A29 DC Blocking Capacitor	N/A	N/A	0955-1131

Assembly	Option 501, 502, 503, 504 and Option 300	Option UNJ	Option 506
B1 Power Supply Fan or B3 Daughterboard/Card Cage Fan	3160-4133	3160-4133	3160-4133
B2 Small Fan	3160-4135	3160-4135	3160-4135
B3 Daughterboard/Card Cage Fan	3160-4133	3160-4133	3160-4133

- a. AT1 High-Power Mechanical Attenuator (Option UNB) is used together with either an A28 Reverse Power Protection or with an A29 DC Blocking Capacitor.

Figure 2-2 E4428C Assemblies from a Top View (Option 501)

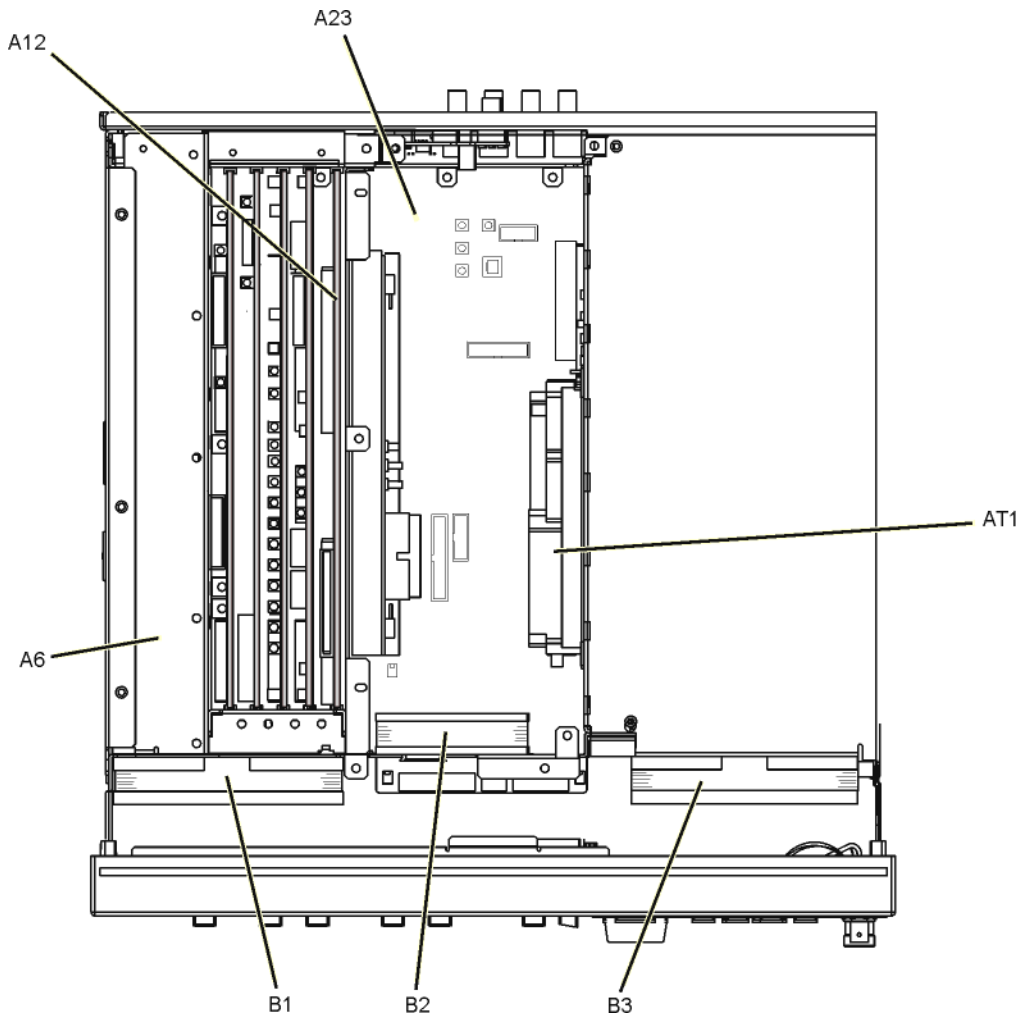
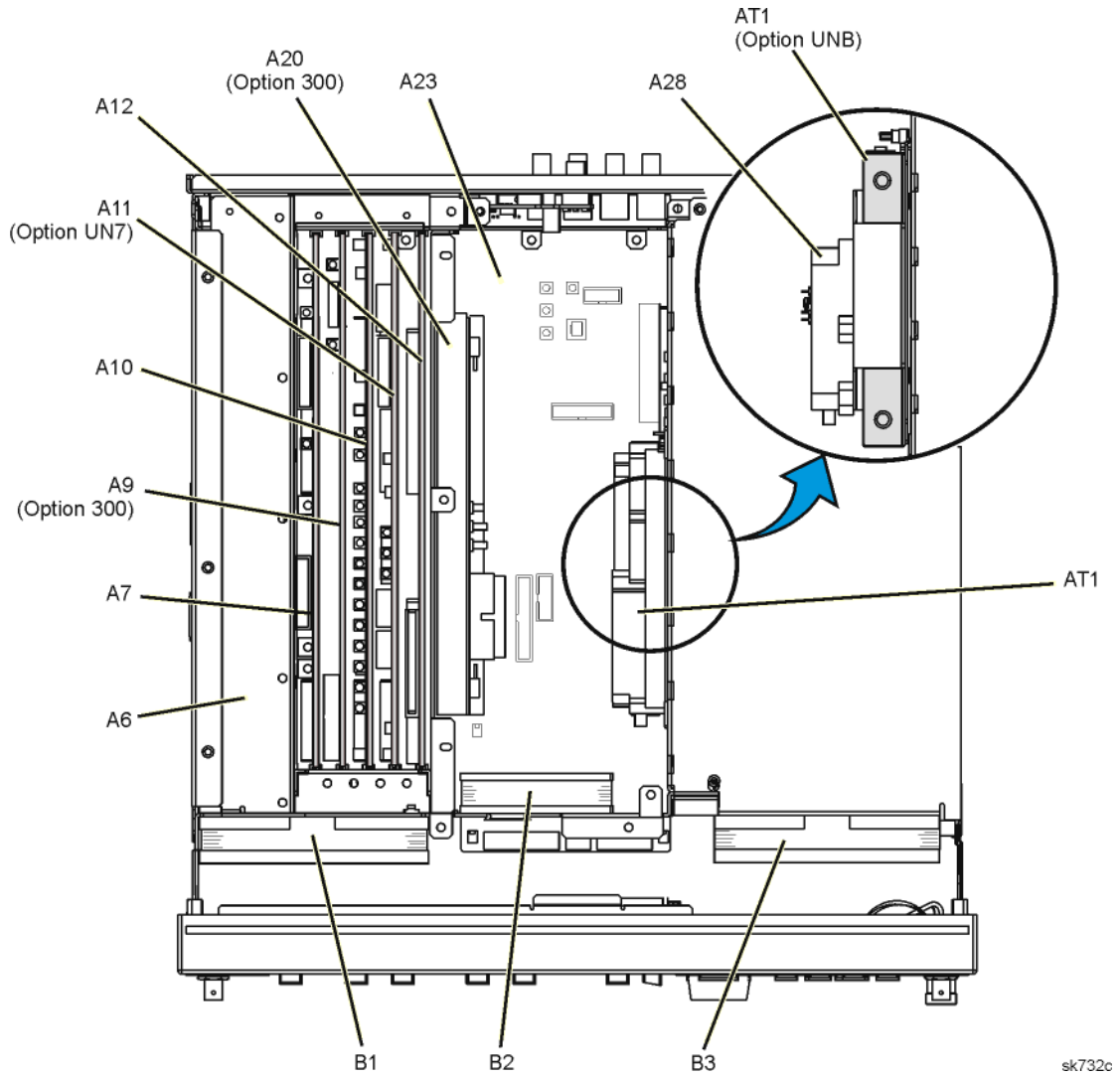

Figure 2-3 E4438C Assemblies from a Top View (Option 501, 502, 503, 504 or Option 300)



sk732c

Figure 2-4 E4428C Assemblies from a Top View (Option UNJ)

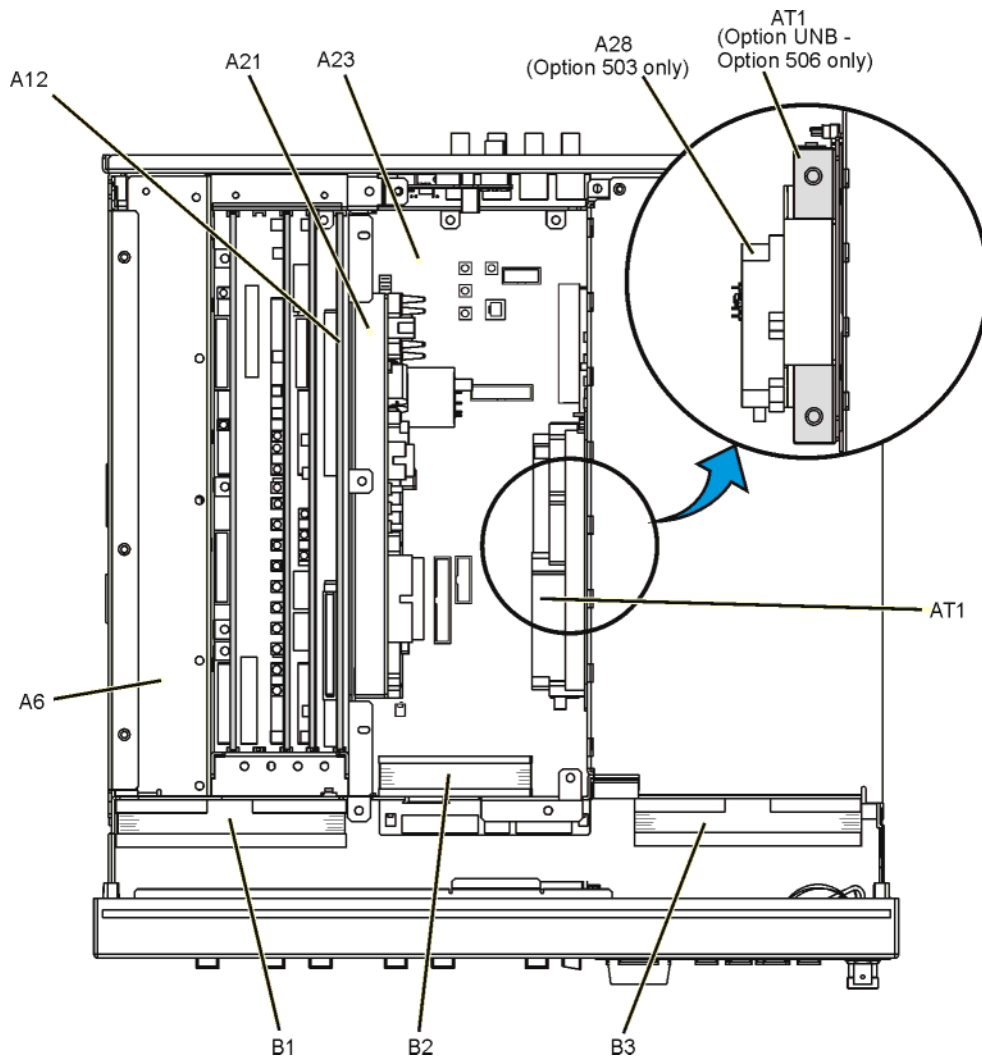
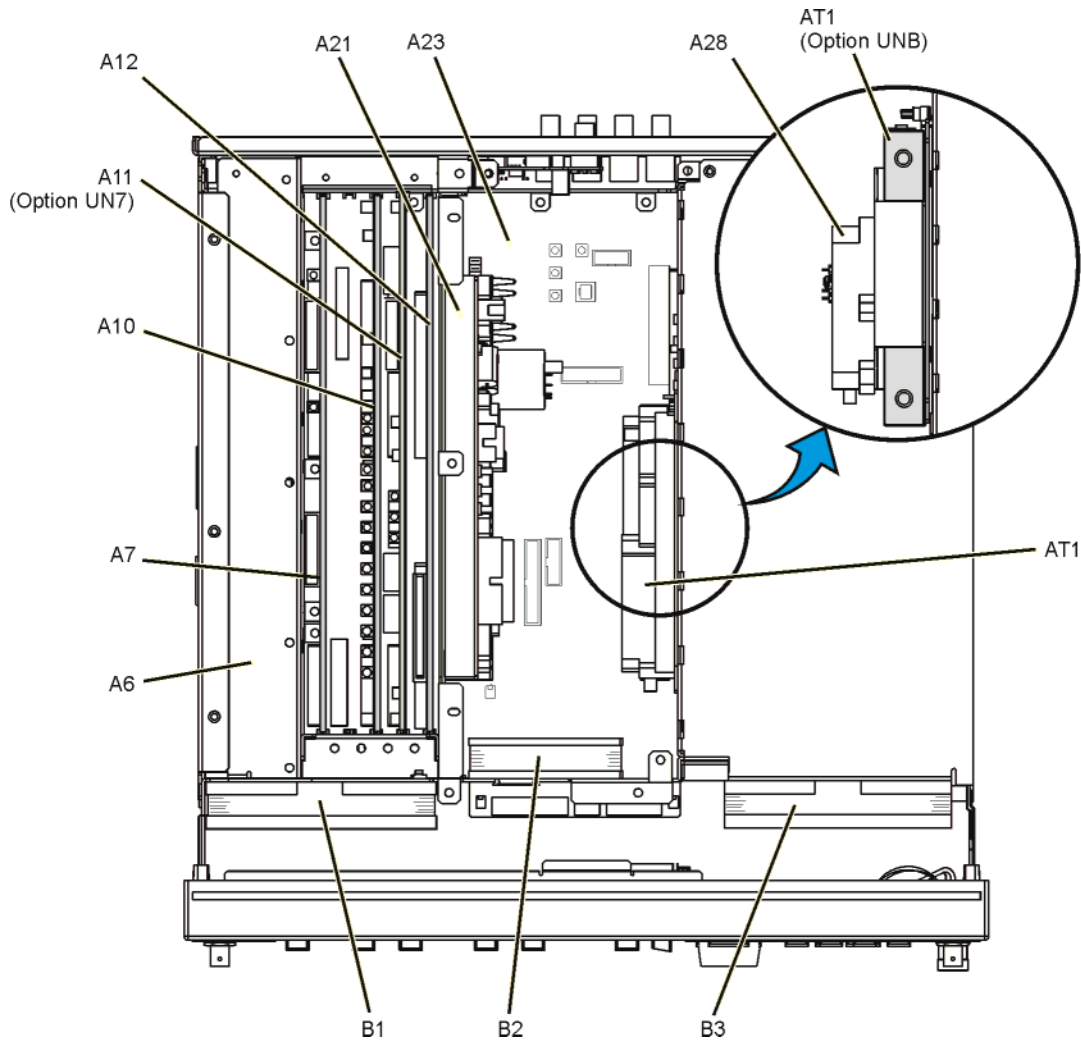

Figure 2-5 E4438C Assemblies from a Top View (Option UNJ)



sk733c

Figure 2-6 E4428C Assemblies from a Top View (Option 506)

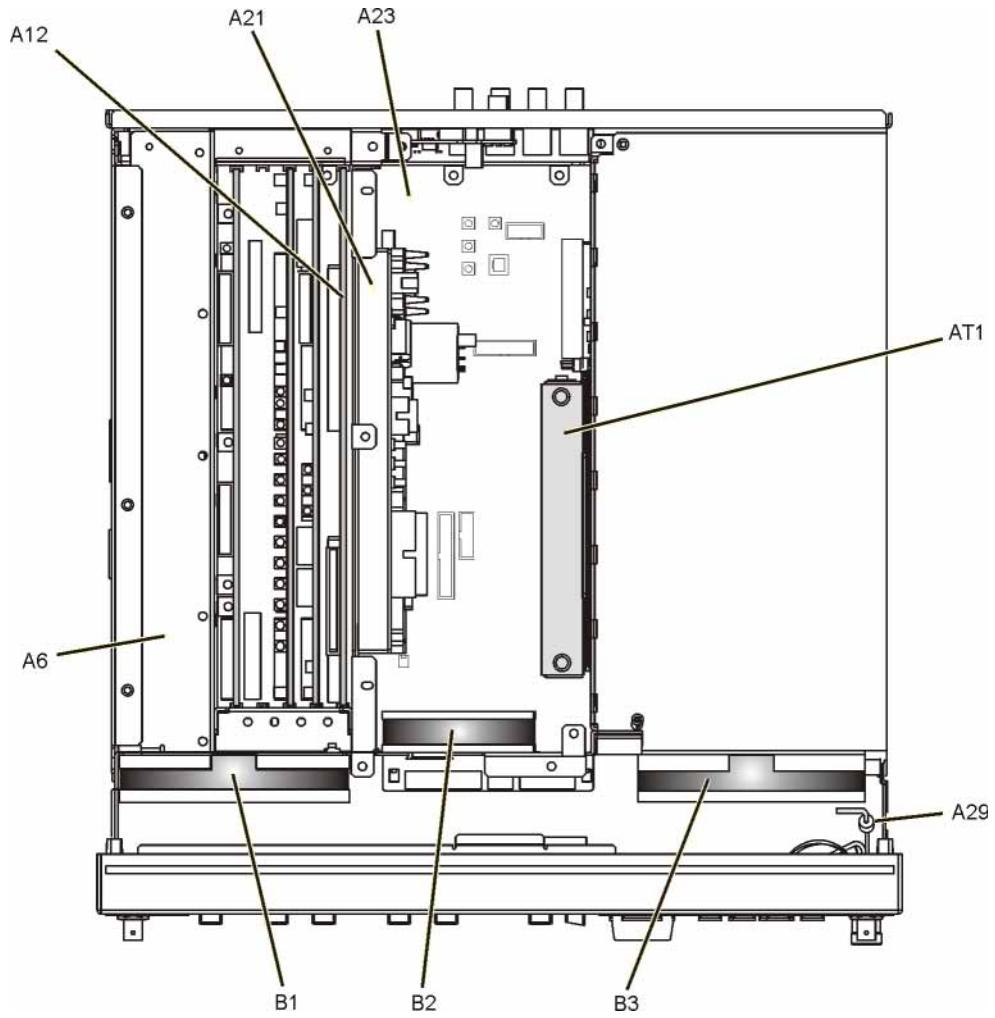
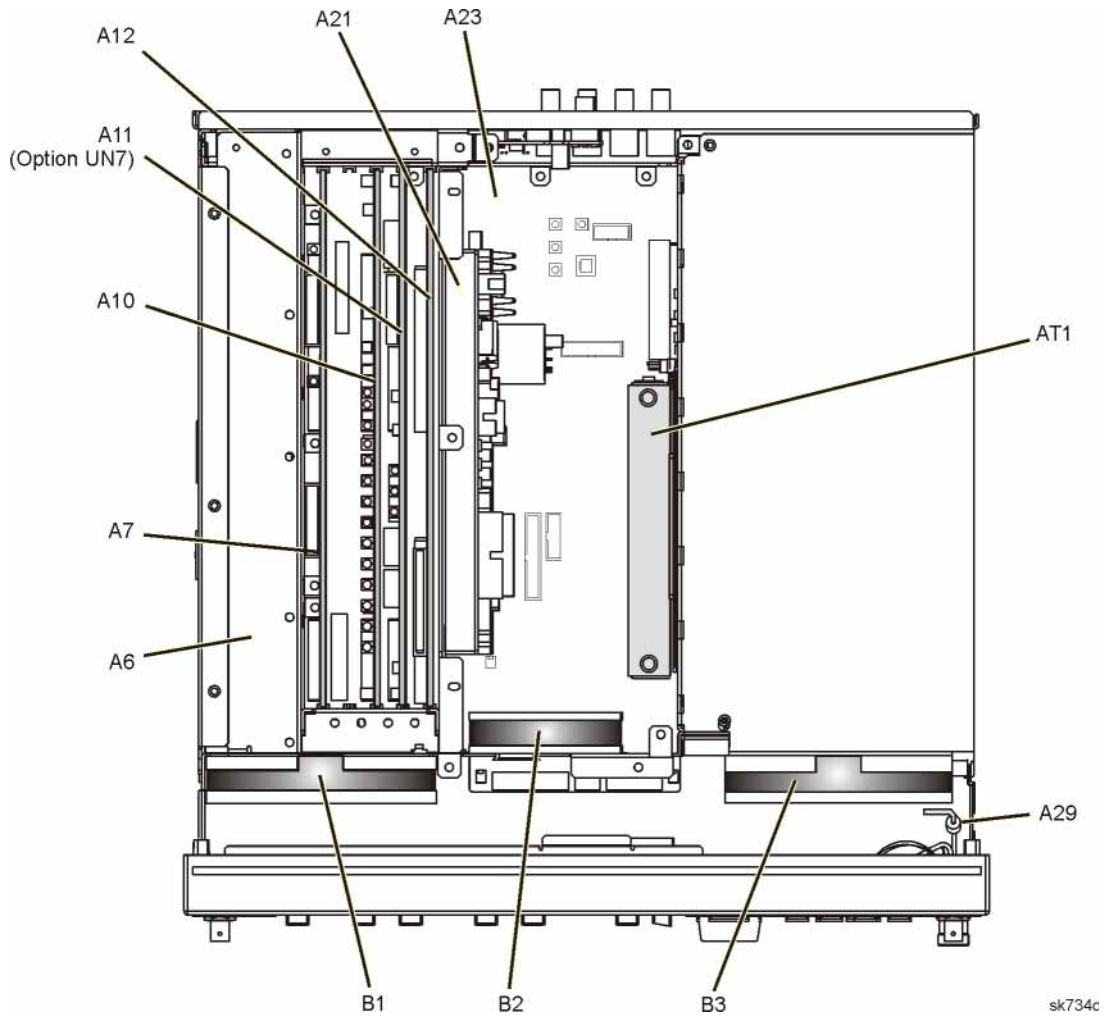

Figure 2-7 E4438C Assemblies from a Top View (Option 506)



Assemblies from a Right-Side View

Refer to [Figure 2-8](#).

Assembly	Option 501, 502, 503, 504 and Option 300	Option UNJ	Option 506
Side-SLOT 1^a A13 Output	E4400-60659	E4400-60659	E4400-60659 also requires Side-SLOT 2
Side-SLOT 2 A14 Extended Frequency Output	N/A	N/A	E4400-60755
Side-SLOT 3 A15 Sampler	N/A	E8251-60043	E8251-60043
Side-SLOT 4 A16 Frac-N or A17 Synthesizer	N/A	E8251-60044	E8251-60044
	E4400-60520	N/A	N/A
Side-SLOT 5 A18 Reference or A18 Reference (Option 501, 502, 503, 504 with Option 1E5)	E4400-60512	E4423-60000	E4423-60500
	E4400-60513	N/A	N/A
A19 Daughterboard	E4400-60719	E4400-60719	E4400-60719

- a. Side-SLOT numbers one through five (where one is on top) refer to the position of an assembly in the right-hand side card-cage of the signal generator.

Figure 2-8 Assemblies from a Right-Side View

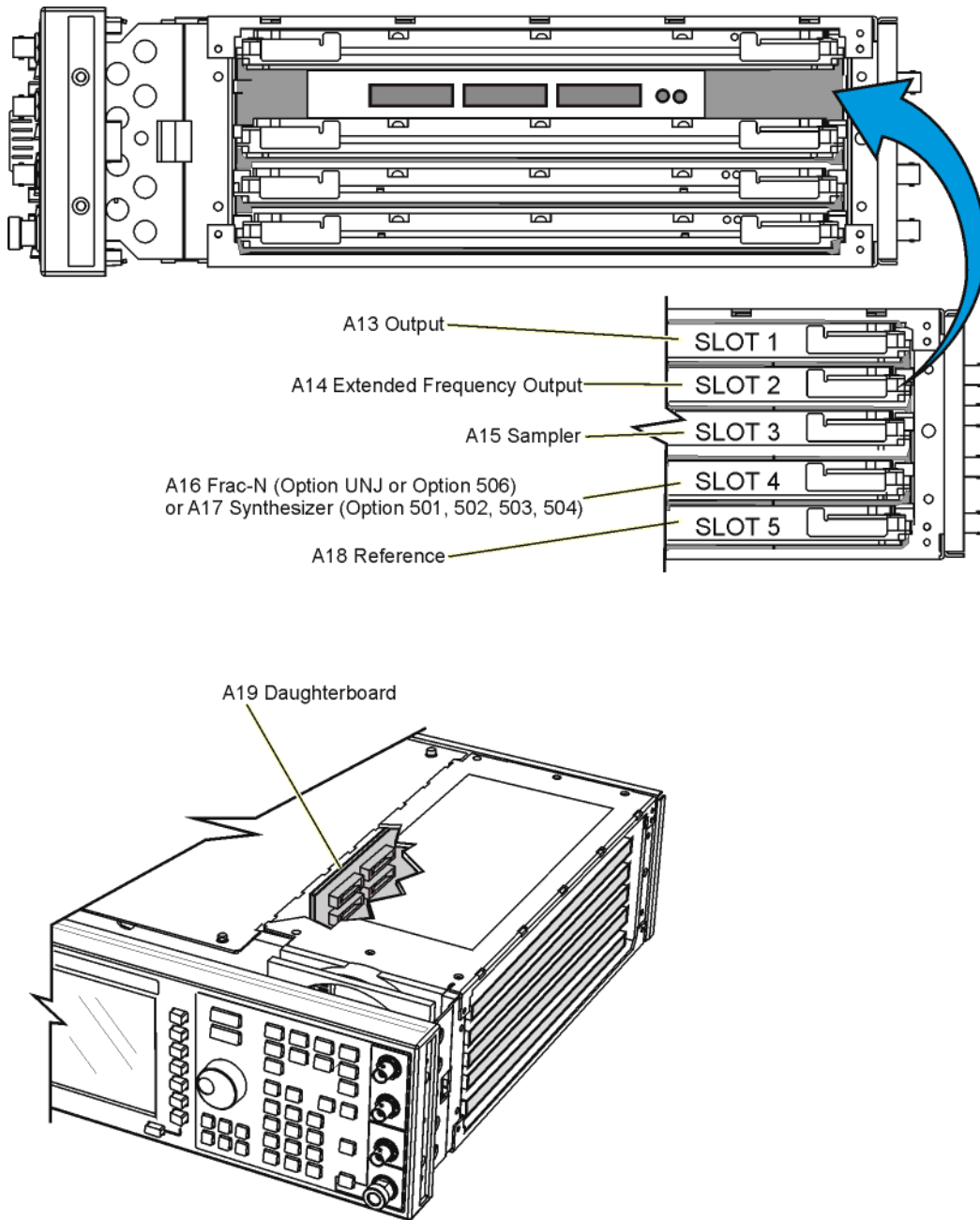

Assemblies of the Front Panel

Refer to [Figure 2-9](#) and [Figure 2-10](#).

Assembly	Option 501, 502, 503, 504 and Option 300	Option UNJ	Option 506
A1 Keyboard	E4400-60502	E4400-60502	E4400-60502
A2 Display	2090-0375	2090-0375	2090-0375
A2DS1 Display Backlight	1513-5204	1513-5204	1513-5204
A3 Front Panel Auxiliary Board	E4400-60503	E4400-60503	E4400-60503
A4 Inverter	0950-3757	0950-3757	0950-3757
A5 Hard Drive (E4438C Only)	E4400-60253	E4400-60253	E4400-60253

Figure 2-9 Assemblies of the Front Panel, for instruments with serial prefixes <US4426/MY4426

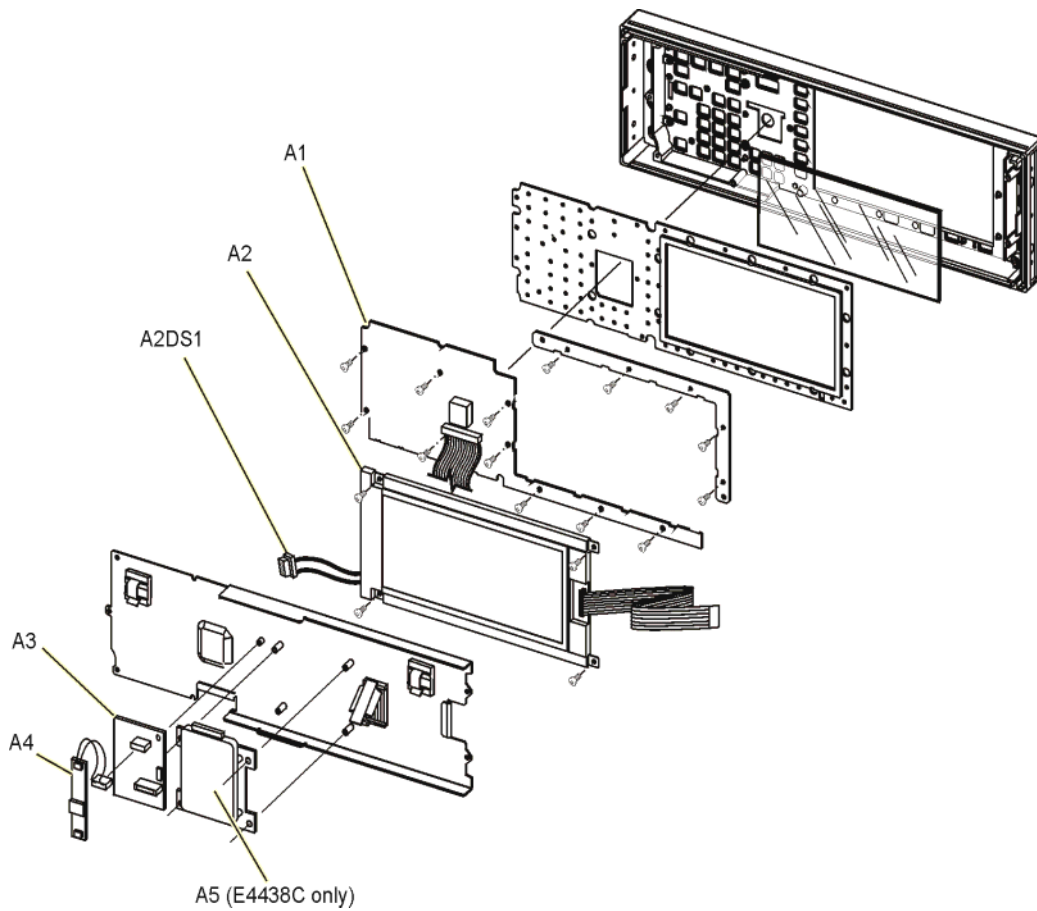

Replaceable Parts
Assemblies of the Front Panel

Figure 2-10 Assemblies of the Front Panel, for Instruments with Serial Prefix \geq US4426/MY4426 and Greater

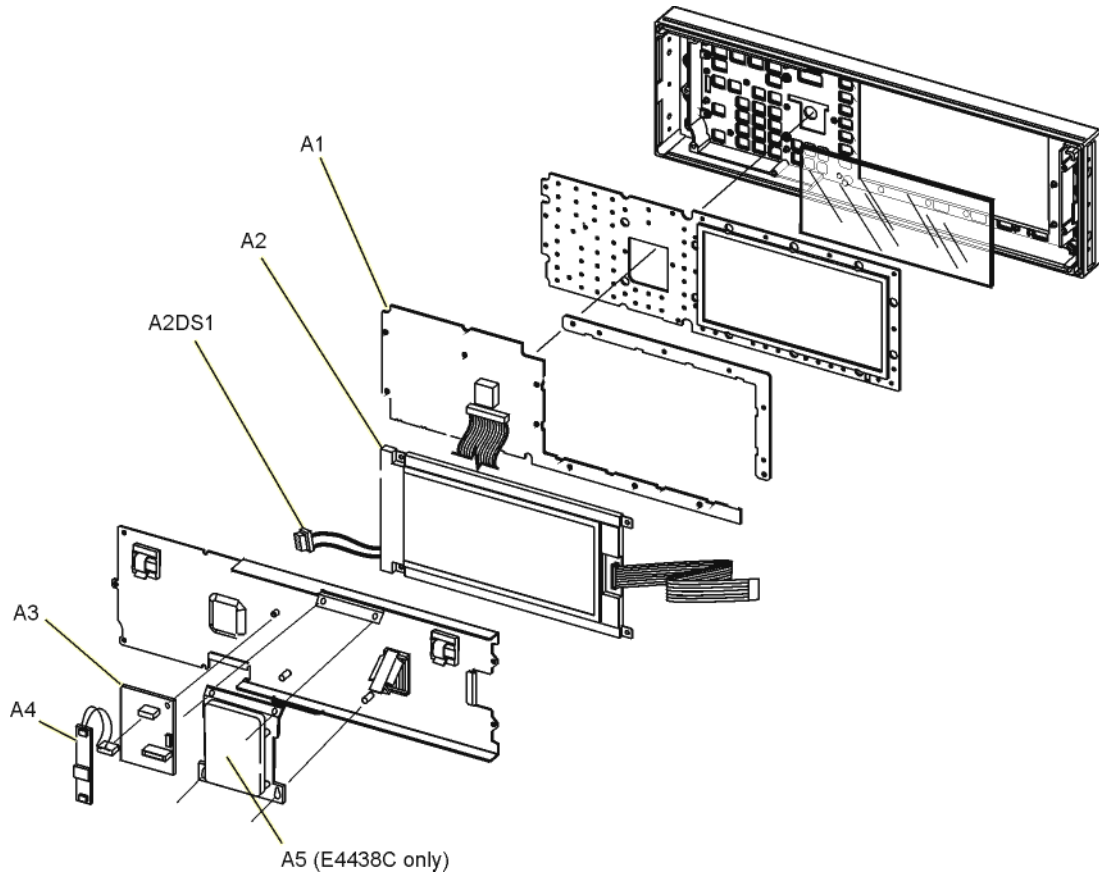

Assemblies of the Inside Rear Panel

Refer to [Figure 2-11](#).

Assembly	Option 501, 502, 503, 504 and Option 300	Option UNJ	Option 506
(for instruments with serial prefixes <US4907/MY4907) A24 Line Module page 2-21	E4400-60537	E4400-60537	E4400-60537
(for instruments with serial prefixes ≥US4907/MY4907) A24 Line Module page 2-21	E4400-60766	E4400-60766	E4400-60766
A25 Rear Panel Board	E4400-60655	E4400-60655	E4400-60655
or A26 Rear Panel LVDS Board (Option 1EM — E4438C Only)	E4400-60524	E4400-60524	E4400-60524
and A27 Rear Panel SMB Board (Option 1EM — E4438C Only)	E4400-60525	E4400-60525	E4400-60525

Figure 2-11 Assemblies of the Inside Rear Panel

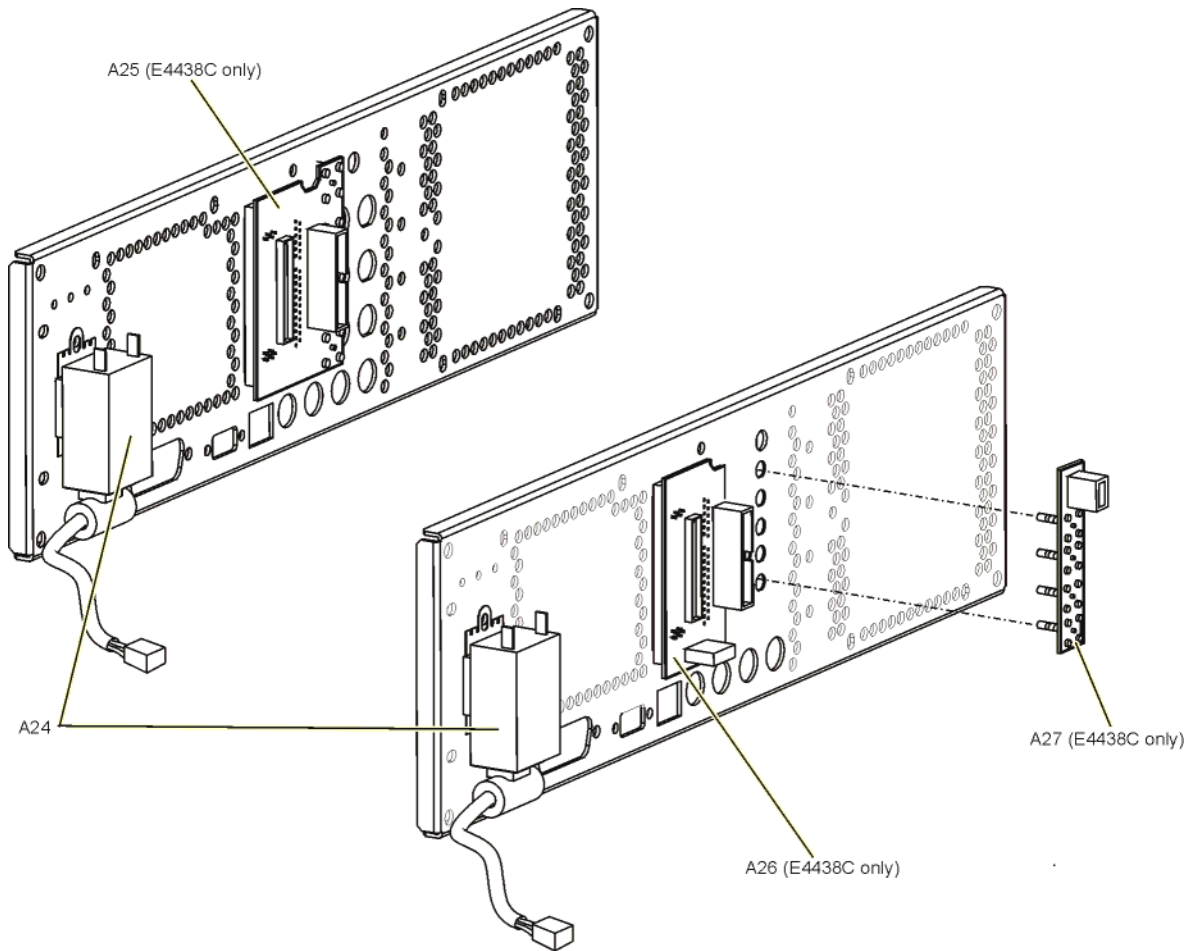

A23BT1 Battery

Refer to [Figure 2-12](#).

Assembly	Option 501, 502, 503, 504 and Option 300	Option UNJ	Option 506
A23BT1 Battery	1420-0356	1420-0356	1420-0356

Figure 2-12 A23BT1 Battery

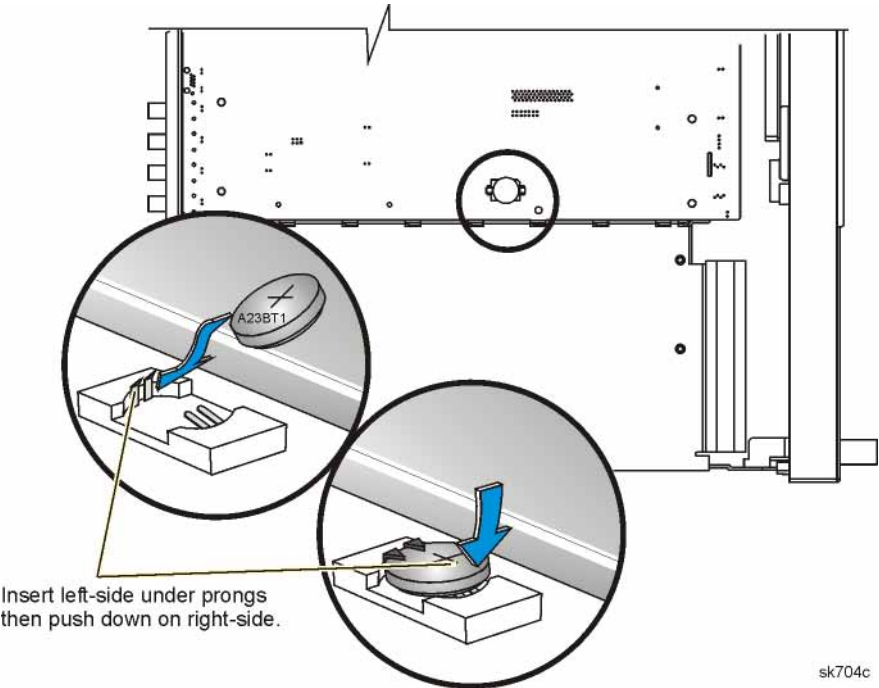

Cables

This section lists part numbers for the cables in your signal generator, in the order shown.

Inside Front Panel and Fan Cables

- “Cables for the Inside Front Panel and Fans” on page 2-26

Option 501, 502, 503, 504 Cables

- “Overall Cables - Includes Cables for Option UN7, 300, 005, and 001/601 or 002/602” on page 2-28
- “Front Panel Cables” on page 2-31
- “Standard Cables - Does Not Include Cables for the Front Panel, Option UN7, 300, or 005” on page 2-32
- “Only Option UN7, 300, 005, and 001/601 or 002/602 Cables” on page 2-33
- “Semi-Rigid Cables - Includes the AT1 Electronic Attenuator or the AT1 High-Power Mechanical Attenuator (Option UNB) with the A28 Reverse Power Protection” on page 2-34
- “Option 1EM Overall Cables - Includes Cables for Option UN7, 300, 005, and 001/601 or 002/602” on page 2-35
- “Option 1EM Semi-Rigid Cables - Includes the AT1 Electronic Attenuator or the AT1 High-Power Mechanical Attenuator (Option UNB) with the A28 Reverse Power Protection” on page 2-38

Option UNJ Cables

- “Overall Cables - Includes Cables for Option UN7, 005, and 001/601 or 002/602” on page 2-39
- “Front Panel Cables” on page 2-42
- “Standard Cables - Does Not Include Cables for the Front Panel, Option UN7, 300, or 005” on page 2-43
- “Only Option UN7, 300, 005, and 001/601 or 002/602 Cables” on page 2-44
- “Semi-Rigid Cables - Includes the A21 YTO Driver and the AT1 Electronic Attenuator or the AT1 High-Power Mechanical Attenuator (Option UNB) with A28 Reverse Power Protection” on page 2-45
- “Option 1EM Overall Cables - Includes Cables for Option UN7, 005, and 001/601 or 002/602” on page 2-47
- “Option 1EM Semi-Rigid Cables - Includes the A21 YTO Driver and the AT1 Electronic Attenuator or the AT1 High-Power Mechanical Attenuator (Option UNB) with A28 Reverse Power Protection” on page 2-50

Option 506 Cables

- “Overall Cables - Includes Cables for Option UN7, 005, and 001/601 or 002/602” on page 2-52
- “Front Panel Cables” on page 2-55
- “Standard Cables - Does Not Include Cables for the Front Panel, Option UN7, or Option 005” on page 2-56
- “Only Option UN7, 005, and 001/601 or 002/602 Cables” on page 2-58
- “Semi-Rigid Cables - Includes the A21 YTO Driver and the AT1 High-Power Mechanical Attenuator (Option UNB) with an A29 DC Blocking Capacitor” on page 2-59
- “Option 1EM Overall Cables - Includes Cables for Option UN7, 005, and 001/601 or 002/602” on page 2-61
- “Option 1EM Semi-Rigid Cables - Includes the A21 YTO Driver and the AT1 High-Power Mechanical Attenuator (Option UNB) with an A29 DC Blocking Capacitor” on page 2-64

Cables for the Inside Front Panel and Fans

Table 2-1

Reference Designator	Input	Output	Part Number
W1 (E4438C)	I INPUT of front panel	A10J7	8121-0642
W2 (E4438C)	Q INPUT of front panel	A10J8	8121-0642
W3 (E4438C)	DATA of front panel	A21J21	8121-0661
W4 (E4438C)	DATA CLOCK of front panel	A23J23	8121-0661
W5 (E4438C)	SYMBOL SYNC of front panel	A23J24	8121-0661
W6 ^a	EXT 1 INPUT of front panel	EXT1 on A19 Daughterboard - refer to the connector diagram located on the daughterboard cover	8121-0644
W7 ^a	EXT 2 INPUT of front panel	EXT2 on A19 Daughterboard - refer to the connector diagram located on the daughterboard cover	8121-0644
W8	LF OUTPUT of front panel	LF OUT A19 Daughterboard - refer to the connector diagram located on the daughterboard cover	8121-0657
W26 (E4438C)	Ribbon Cable, A5 10 GB Hard Drive	A12P3	8121-0685
W33	Ribbon Cable, A2 Display	A3J1	8121-0689
W34	Wire Cable, CN1 (top-side) of A4 Inverter	A3P2	8121-0687
W35	Ribbon Cable, A3 Front Panel Auxiliary Board	A23J3	8121-0686
W36 ^b	Ribbon Cable, A1 Keyboard	A28J32	part of A1
A2DS1W1 ^b	Wire Cable, A2DS1 Display Backlight	CN2 (bottom-side) of the A4 Inverter	part of A2
B1W1 ^b	Wire Cable, B1 Power Supply Fan	A23J33	part of B1
B2W1 ^b	Wire Cable, B2 Small Fan	A23J27	part of B2
B3W1 ^b	Wire Cable, B3 Daughterboard/Card Cage Fan	A23J29	part of B3

Cables for the Inside Front Panel and Fans

- a. When comparing cables W6 and W7 between a model with Option 506 and a model with either Option 501, 502, 503, 504, or UNJ, notice that cables W6 and W7 are connected to different (swapped) ports of the A19 Daughterboard.
- b. This cable is not replaceable by itself; it is part of an assembly.

Cables for Option 501, 502, 503, 504 Signal Generators

Overall Cables - Includes Cables for Option UN7, 300, 005, and 001/601 or 002/602)

Table 2-2

Reference Designator	Input	Output	Part Number
W1 (E4438C)	I INPUT of front panel	A10J7	8121-0642
W2 (E4438C)	Q INPUT of front panel	A10J8	8121-0642
W3 (E4438C)	DATA of front panel	A21J21	8121-0661
W4 (E4438C)	DATA CLOCK of front panel	A23J23	8121-0661
W5 (E4438C)	SYMBOL SYNC of front panel	A23J24	8121-0661
W6 ^a	EXT 1 INPUT of front panel	EXT1 on A19 Daughterboard - refer to the connector diagram located on the daughterboard cover	8121-0644
W7 ^a	EXT 2 INPUT of front panel	EXT2 on A19 Daughterboard - refer to the connector diagram located on the daughterboard cover	8121-0644
W8	LF OUTPUT of front panel	LF OUT A19 Daughterboard - refer to the connector diagram located on the daughterboard cover	8121-0657
W10 (Option 001/601 or 002/602 — E4438C)	Ribbon Cable, A7J13	A9J3 (Option 501, 502, 503, 504 with Option 300) or A11J3 (Option UN7) or A25P2	8121-0679
W12 (Option 001/601 or 002/602 — E4438C)	A7J800	BASEBAND GEN REF IN of the rear panel	8121-0643
W13 (Option 300 — E4438C)	A9J4	A20 Downconverter	8121-0651
W14 (Option 300 — E4438C)	A9J15	A20 Downconverter	8121-0651
W15 (E4438C)	A10J14	Q bar OUT of the rear panel	8121-0640

Table 2-2

Reference Designator	Input	Output	Part Number
W16 (E4438C)	A10J13	I bar OUT of the rear panel	8121-0640
W17 (E4438C)	A10J12	Q OUT of the rear panel	8121-0640
W18 (E4438C)	A10J11	I OUT of the rear panel	8121-0640
W19 (E4438C)	A10J10	Q INT LOW on A19 Daughterboard - refer to the connector diagram located on the daughterboard cover	8121-0641
W20 (E4438C)	A10J9	I INT on A19 Daughterboard - refer to the connector diagram located on the daughterboard cover	8121-0641
W23 (Option UN7 — E4438C)	A11J4	BER DATA IN of the rear panel	8121-0659
W24 (Option UN7 — E4438C)	A11J5	BER CLK IN of the rear panel	8121-0659
W25 (Option UN7 — E4438C)	A11J6	BER GATE IN of the rear panel	8121-0659
W26 (Option 005 — E4438C)	Ribbon Cable, A5 10 GB Hard Drive	A12P3	8121-0685
W31	A23J20	SWEEP OUT of the rear panel	8121-0658
W32	A23J36	A25P4	8121-0678
W40	Ribbon Cable, AT1 Electronic Attenuator	A23J25	8121-6837
W43	Semi-Rigid Cable, output of A13 Output	input of AT1 Electronic Attenuator - passes through the A19 Daughterboard	E4400-60625
W63 (Option 300 — E4438C)	Ribbon Cable, A20 Downconverter	A23J26	8121-0682
W64 (Option 300 — E4438C)	A20 Downconverter	321.4 IN of the rear panel	8121-0650

Cables for Option 501, 502, 503, 504 Signal Generators

Table 2-2

Reference Designator	Input	Output	Part Number
W92 (Option 001/601 or 002/602 — E4438C)	Ribbon Cable, A7J21	A25P1	8121-0690

- a. When comparing cables W6 and W7 between a model with Option 506 and a model with either Option 501, 502, 503, 504, or UNJ, notice that cables W6 and W7 are connected to different (swapped) ports of the A19 Daughterboard.

Front Panel Cables

Table 2-3

Reference Designator	Input	Output	Part Number
W1 (E4438C)	I INPUT of front panel	A10J7	8121-0642
W2 (E4438C)	Q INPUT of front panel	A10J8	8121-0642
W3 (E4438C)	DATA of front panel	A21J21	8121-0661
W4 (E4438C)	DATA CLOCK of front panel	A23J23	8121-0661
W5 (E4438C)	SYMBOL SYNC of front panel	A23J24	8121-0661
W6 ^a	EXT 1 INPUT of front panel	EXT1 on A19 Daughterboard - refer to the connector diagram located on the daughterboard cover	8121-0644
W7 ^a	EXT 2 INPUT of front panel	EXT2 on A19 Daughterboard - refer to the connector diagram located on the daughterboard cover	8121-0644
W8	LF OUTPUT of front panel	LF OUT A19 Daughterboard - refer to the connector diagram located on the daughterboard cover	8121-0657

- a. When comparing cables W6 and W7 between a model with Option 506 and a model with either Option 501, 502, 503, 504, or UNJ, notice that cables W6 and W7 are connected to different (swapped) ports of the A19 Daughterboard.

Standard Cables - Does Not Include Cables for the Front Panel, Option UN7, 300, or 005

Table 2-4

Reference Designator	Input	Output	Part Number
W10 (Option 001/601 or 002/602 — E4438C)	Ribbon Cable, A7J13	A9J3 (Option 501, 502, 503, 504 with Option 300) or A11J3 (Option UN7) or A25P2	8121-0679
W12 (Option 001/601 or 002/602 — E4438C)	A7J800	BASEBAND GEN REF IN of the rear panel	8121-0643
W15 (E4438C)	A10J14	Q bar OUT of the rear panel	8121-0640
W16 (E4438C)	A10J13	I bar OUT of the rear panel	8121-0640
W17 (E4438C)	A10J12	Q OUT of the rear panel	8121-0640
W18 (E4438C)	A10J11	I OUT of the rear panel	8121-0640
W19 (E4438C)	A10J10	Q INT LOW on A19 Daughterboard - refer to the connector diagram located on the daughterboard cover	8121-0641
W20 (E4438C)	A10J9	I INT on A19 Daughterboard - refer to the connector diagram located on the daughterboard cover	8121-0641
W31	A23J20	SWEEP OUT of the rear panel	8121-0658
W32	A23J36	A25P4	8121-0678
W40	Ribbon Cable, AT1 Electronic Attenuator	A23J25	8121-6837
W43	Semi-Rigid Cable, output of A13 Output	input of AT1 Electronic Attenuator - passes through the A19 Daughterboard	E4400-60625
W92 (Option 001/601 or 002/602 — E4438C)	Ribbon Cable, A7J21	A25P1	8121-0690

Only Option UN7, 300, 005, and 001/601 or 002/602 Cables

Table 2-5

Reference Designator	Input	Output	Part Number
W10 (Option 001/601 or 002/602 — E4438C)	Ribbon Cable, A7J13	A9J3 (Option 501, 502, 503, 504 with Option 300) or A11J3 (Option UN7) or A25P2	8121-0679
W12 (Option 001/601 or 002/602 — E4438C)	A7J800	BASEBAND GEN REF IN of the rear panel	8121-0643
W13 (Option 300 — E4438C)	A9J4	A20 Downconverter	8121-0651
W14 (Option 300 — E4438C)	A9J15	A20 Downconverter	8121-0651
W23 (Option UN7 — E4438C)	A11J4	BER DATA IN of the rear panel	8121-0659
W24 (Option UN7 — E4438C)	A11J5	BER CLK IN of the rear panel	8121-0659
W25 (Option UN7 — E4438C)	A11J6	BER GATE IN of the rear panel	8121-0659
W26 (Option 005 — E4438C)	Ribbon Cable, A5 10 GB Hard Drive	A12P3	8121-0685
W63 (Option 300 — E4438C)	Ribbon Cable, A20 Downconverter	A23J26	8121-0682
W64 (Option 300 — E4438C)	A20 Downconverter	321.4 IN of the rear panel	8121-0650
W92 (Option 001/601 or 002/602 — E4438C)	Ribbon Cable, A7J21	A25P1	8121-0690

Semi-Rigid Cables - Includes the AT1 Electronic Attenuator or the AT1 High-Power Mechanical Attenuator (Option UNB) with the A28 Reverse Power Protection

Table 2-6

Reference Designator	Input	Output	Part Number
W9	Semi-Rigid Cable, output of AT1 Electronic Attenuator	RF OUTPUT of the front panel	E4400-20554
W31	A23J20	SWEEP OUT of the rear panel	8121-0658
W32	A23J36	A25P4	8121-0678
W40	Ribbon Cable, AT1 Electronic Attenuator	A23J25	8121-6837
W41	Semi-Rigid Cable, output of A17 Synthesizer	A13 Output - passes through the A19 Daughterboard	E4400-60623
W42 (E4438C)	Semi-Rigid Cable, output of A13 Output	COH CARRIER of the rear panel - passes through A19 Daughterboard	E4400-60624
W43	Semi-Rigid Cable, output of A13 Output	input of AT1 Electronic Attenuator - passes through A19 Daughterboard	E4400-60625
When using the AT1 High-Power Mechanical Attenuator (Option UNB) with the A28 Reverse Power Protection the following cables will apply			
W47	Semi-Rigid Cable, output of A13 Output	input of AT1 High-Power Mechanical Attenuator - passes through A19 Daughterboard	E4400-60627
W48	Semi-Rigid Cable, AT1 High-Power Mechanical Attenuator	input of A28 Reverse Power Protection	E4400-20550
W49	Semi-Rigid Cable, A28 Reverse Power Protection	RF OUTPUT of the rear panel	E4400-20551
W53	Wire-Harness, control lines of the A28 Reverse Power Protection	A23J22	08647-61028
W57	Ribbon Cable, AT1 High-Power Mechanical Attenuator	A23J25	E4400-20132

Option 1EM Overall Cables - Includes Cables for Option UN7, 300, 005, and 001/601 or 002/602)

Table 2-7

Reference Designator	Input	Output	Part Number
W10 (Option 001/601 or 002/602 — E4438C)	Ribbon Cable, A7J13	A9J3 (Option 501, 502, 503, 504 with Option 300) or A11J3 (Option UN7) or A25P2	8121-0679
W13 (Option 300 — E4438C)	A9J4	A20 Downconverter	8121-0651
W14 (Option 300 — E4438C)	A9J15	A20 Downconverter	8121-0651
W19 (E4438C)	A10J10	Q INT LOW on A19 Daughterboard - refer to the connector diagram located on the daughterboard cover	8121-0641
W20 (E4438C)	A10J9	I INT on A19 Daughterboard - refer to the connector diagram located on the daughterboard cover	8121-0641
W23 (Option UN7 — E4438C)	A11J4	BER DATA IN of the rear panel	8121-0659
W24 (Option UN7 — E4438C)	A11J5	BER CLK IN of the rear panel	8121-0659
W25 (Option UN7 — E4438C)	A11J6	BER GATE IN of the rear panel	8121-0659
W26 (Option 005 — E4438C)	Ribbon Cable, A5 10 GB Hard Drive	A12P3	8121-0685
W32	A23J36	A25P4	8121-0678
W40	Ribbon Cable, AT1 Electronic Attenuator	A23J25	8121-6837
W43	Semi-Rigid Cable, output of A13 Output	input of AT1 Electronic Attenuator - passed through the A19 Daughterboard	E4400-60625
W63 (Option 300 — E4438C)	Ribbon Cable, A20 Downconverter	A23J26	8121-0682

Table 2-7

Reference Designator	Input	Output	Part Number
W64 (Option 300 — E4438C)	A20 Downconverter	321.4 IN of the rear panel	8121-0650
W70 ^a	EXT 1 of the rear panel	EXT 1 of A19 Daughterboard - refer to the connector diagram located on the daughterboard cover	8121-0654
W71 ^a	EXT 2 of the rear panel	EXT 2 of A19 Daughterboard - refer to the connector diagram located on the daughterboard cover	8121-0654
W72 (E4438C)	I IN of the rear panel	A10J7	8121-0652
W73 (E4438C)	Q IN of the rear panel	A10J8	8121-0652
W74 (E4438C)	A10J11	I OUT of the rear panel	8121-0653
W75 (E4438C)	A10J12	Q OUT of the rear panel	8121-0653
W76 (E4438C)	A10J13	I bar OUT of the rear panel	8121-0653
W77 (E4438C)	A10J14	Q bar OUT of the rear panel	8121-0653
W78 (Option 001/601 or 002/602 — E4438C)	A7J800	BASEBAND GEN REF IN of the rear panel	8121-0655
W79	A23J20	SWP OUT of the rear panel	8121-0660
W80 (E4438C)	DATA IN of the rear panel	A23J21	8121-0660
W81 (E4438C)	DATA CLK IN of the rear panel	A23J23	8121-0660
W82 (E4438C)	SYMBOL SYNC IN of the rear panel	A23J24	8121-0660
W83	A19 Daughterboard	LF OUT of the rear panel	8121-0656
W92 (Option 001/601 or 002/602 — E4438C)	Ribbon Cable, A7J21	A25P1	8121-0690

Cables for Option 501, 502, 503, 504 Signal Generators

- a. When comparing cables W70 and W71 between a model with Option 506 and a model with either Option 501, 502, 503, 504, or UNJ, notice that cables W70 and W71 are connected to different (swapped) ports of the A19 Daughterboard.

Option 1EM Semi-Rigid Cables - Includes the AT1 Electronic Attenuator or the AT1 High-Power Mechanical Attenuator (Option UNB) with the A28 Reverse Power Protection

Table 2-8

Reference Designator	Input	Output	Part Number
W32 (E4438C)	A23J36	A25P4	8121-0678
W40	Ribbon Cable, AT1 Electronic Attenuator	A23J25	8121-6837
W41	Semi-Rigid Cable, output of A17 Synthesizer	A13 Output - passes through the A19 Daughterboard	E4400-60623
W43	Semi-Rigid Cable, output of A13 Output	input of AT1 Electronic Attenuator - passes through the A19 Daughterboard	E4400-60625
W46	Semi-Rigid Cable, A28 Reverse Power Protection	RF OUTPUT of the rear panel	8121-6837
W84 (E4438C)	Semi-Rigid Cable, output of A13 Output	COH CARRIER of the rear panel - passes through A19 Daughterboard	E4400-60631
When using the AT1 High-Power Mechanical Attenuator (Option UNB) with the A28 Reverse Power Protection the following cables will apply.			
W47	Semi-Rigid Cable, output of A13 Output	input of AT1 High-Power Mechanical Attenuator - passes through A19 Daughterboard	E4400-60627
W48	Semi-Rigid Cable, AT1 High-Power Mechanical Attenuator	input of A28 Reverse Power Protection	E4400-20550
W53	wire-harness, control lines of the A28 Reverse Power Protection	A23J22	08647-61028
W57	Ribbon Cable, AT1 High-Power Mechanical Attenuator	A23J25	E4400-20132
W79	A23J20	SWP OUT of the rear panel	8121-0660
W84 (E4438C)	Semi-Rigid Cable, output of A13 Output	COH CARRIER of the rear panel - passes through A19 Daughterboard	E4400-60631
W85	Semi-Rigid Cable, output of AT1 Electronic Attenuator	RF OUTPUT of the rear panel	E4400-20555

Cables for Option UNJ Signal Generators

Overall Cables - Includes Cables for Option UN7, 005, and 001/601 or 002/602

Table 2-9

Reference Designator	Input	Output	Part Number
W1 (E4438C)	I INPUT of front panel	A10J7	8121-0642
W2 (E4438C)	Q INPUT of front panel	A10J8	8121-0642
W3 (E4438C)	DATA of front panel	A21J21	8121-0661
W4 (E4438C)	DATA CLOCK of front panel	A23J23	8121-0661
W5 (E4438C)	SYMBOL SYNC of front panel	A23J24	8121-0661
W6 ^a	EXT 1 INPUT of front panel	EXT1 on A19 Daughterboard - refer to the connector diagram located on the daughterboard cover	8121-0644
W7 ^a	EXT 2 INPUT of front panel	EXT2 on A19 Daughterboard - refer to the connector diagram located on the daughterboard cover	8121-0644
W8	LF OUTPUT of front panel	LF OUT A19 Daughterboard - refer to the connector diagram located on the daughterboard cover	8121-0657
W10 (Option 001/601 or 002/602 — E4438C)	Ribbon Cable, A7J13	A9J3 (Option 501, 502, 503, 504 with Option 300) or A11J3 (Option UN7) or A25P2	8121-0679
W11	Semi-Rigid Cable, output of A16 Frac-N	input of A15 Sampler - passes through A19 Daughterboard	E4400-60622
W12 (Option 001/601 or 002/602 — E4438C)	A7J800	BASEBAND GEN REF IN of the rear panel	8121-0643
W15 (E4438C)	A10J14	Q bar OUT of the rear panel	8121-0640
W16 (E4438C)	A10J13	I bar OUT of the rear panel	8121-0640

Table 2-9

Reference Designator	Input	Output	Part Number
W17 (E4438C)	A10J12	Q OUT of the rear panel	8121-0640
W18 (E4438C)	A10J11	I OUT of the rear panel	8121-0640
W19 (E4438C)	A10J10	Q INT LOW on A19 Daughterboard - refer to the connector diagram located on the daughterboard cover	8121-0641
W20 (E4438C)	A10J9	I INT on A19 Daughterboard - refer to the connector diagram located on the daughterboard cover	8121-0641
W23 (Option UN7 — E4438C)	A11J4	BER DATA IN of the rear panel	8121-0659
W24 (Option UN7 — E4438C)	A11J5	BER CLK IN of the rear panel	8121-0659
W25 (Option UN7 — E4438C)	A11J6	BER GATE IN of the rear panel	8121-0659
W26 (Option 005 — E4438C)	Ribbon Cable, A5 10 GB Hard Drive	A12P3	8121-0685
W27	A21J2	A23J34	8121-0684
W28	A21J3	YTO FM on A19 Daughterboard - refer to the connector diagram located on the daughterboard cover	8121-0645
W29	A21J4	PH LK on A19 Daughterboard - refer to the connector diagram located on the daughterboard cover	8121-0645
W30	A21J5	J1 of YTO Interface board	8121-0683
W31	A23J20	SWEEP OUT of rear panel	8121-0658
W32 (E4438C)	A23J36	A25P4	8121-0678
W40	Ribbon Cable, AT1 Electronic Attenuator	A23J25	8121-6837

Table 2-9

Reference Designator	Input	Output	Part Number
W43	Semi-Rigid Cable, output of A13 Output	input of AT1 Electronic Attenuator - passes through the A19 Daughterboard	E4400-60625
W92 (Option 001/601 or 002/602 — E4438C)	Ribbon Cable, A7J21	A25P1	8121-0690

- a. When comparing cables W6 and W7 between a model with Option 506 and a model with either Option 501, 502, 503, 504, or UNJ, notice that cables W6 and W7 are connected to different (swapped) ports of the A19 Daughterboard.

Front Panel Cables

Table 2-10

Reference Designator	Input	Output	Part Number
W1 (E4438C)	I INPUT of front panel	A10J7	8121-0642
W2 (E4438C)	Q INPUT of front panel	A10J8	8121-0642
W3 (E4438C)	DATA of front panel	A21J21	8121-0661
W4 (E4438C)	DATA CLOCK of front panel	A23J23	8121-0661
W5 (E4438C)	SYMBOL SYNC of front panel	A23J24	8121-0661
W6 ^a	EXT 1 INPUT of front panel	EXT1 on A19 Daughterboard - refer to the connector diagram located on the daughterboard cover	8121-0644
W7 ^a	EXT 2 INPUT of front panel	EXT2 on A19 Daughterboard - refer to the connector diagram located on the daughterboard cover	8121-0644
W8	LF OUTPUT of front panel	LF OUT A19 Daughterboard - refer to the connector diagram located on the daughterboard cover	8121-0657

- a. When comparing cables W6 and W7 between a model with Option 506 and a model with either Option 501, 502, 503, 504, or UNJ, notice that cables W6 and W7 are connected to different (swapped) ports of the A19 Daughterboard.

Standard Cables - Does Not Include Cables for the Front Panel, Option UN7, 300, or 005

Table 2-11

Reference Designator	Input	Output	Part Number
W10 (Option 001/601 or 002/602 — E4438C)	Ribbon Cable, A7J13	A9J3 (Option 501, 502, 503, 504 with Option 300) or A11J3 (Option UN7) or A25P2	8121-0679
W11	Semi-Rigid Cable, output of A16 Frac-N	input of A15 Sampler - passes through A19 Daughterboard	E4400-60622
W12 (Option 001/601 or 002/602 — E4438C)	A7J800	BASEBAND GEN REF IN of the rear panel	8121-0643
W15 (E4438C)	A10J14	Q bar OUT of the rear panel	8121-0640
W16 (E4438C)	A10J13	I bar OUT of the rear panel	8121-0640
W17 (E4438C)	A10J12	Q OUT of the rear panel	8121-0640
W18 (E4438C)	A10J11	I OUT of the rear panel	8121-0640
W19 (E4438C)	A10J10	Q INT LOW on A19 Daughterboard - refer to the connector diagram located on the daughterboard cover	8121-0641
W20 (E4438C)	A10J9	I INT on A19 Daughterboard - refer to the connector diagram located on the daughterboard cover	8121-0641
W31	A23J20	SWEEP OUT of the rear panel	8121-0658
W32	A23J36	A25P4	8121-0678
W40	Ribbon Cable, AT1 Electronic Attenuator	A23J25	8121-6837
W43	Semi-Rigid Cable, output of A13 Output	input of AT1 Electronic Attenuator - passes through the A19 Daughterboard	E4400-60625
W92 (Option 001/601 or 002/602 — E4438C)	Ribbon Cable, A7J21	A25P1	8121-0690

Only Option UN7, 300, 005, and 001/601 or 002/602 Cables

Table 2-12

Reference Designator	Input	Output	Part Number
W10 (Option 001/601 or 002/602 — E4438C)	Ribbon Cable, A7J13	A9J3 (Option 501, 502, 503, 504 with Option 300) or A11J3 (Option UN7) or A25P2	8121-0679
W12 (Option 001/601 or 002/602 — E4438C)	A7J800	BASEBAND GEN REF IN of the rear panel	8121-0643
W23 (Option UN7 — E4438C)	A11J4	BER DATA IN of the rear panel	8121-0659
W24 (Option UN7 — E4438C)	A11J5	BER CLK IN of the rear panel	8121-0659
W25 (Option UN7 — E4438C)	A11J6	BER GATE IN of the rear panel	8121-0659
W92 (Option 001/601 or 002/602 — E4438C)	Ribbon Cable, A7J21	A25P1	8121-0690

Semi-Rigid Cables - Includes the A21 YTO Driver and the AT1 Electronic Attenuator or the AT1 High-Power Mechanical Attenuator (Option UNB) with A28 Reverse Power Protection

Table 2-13

Reference Designator	Input	Output	Part Number
W9	Semi-Rigid Cable, output of AT1 Electronic Attenuator	RF OUPUT of the front panel	E4400-20554
W11	Semi-Rigid Cable, output of the A16 Frac-N	input of the A15 Sampler - passes through the A19 Daughterboard	E4400-60622
W31	A23J20I	SWEEP OUT of the rear panel	8121-0658
W32 (E4438C)	A23J36	A25P4	8121-0678
W37	Semi-Rigid Cable, A15 Sampler - passes through the A19 Daughterboard	top connector of A21 YTO Driver	E4423-20510
W38	Semi-Rigid Cable, A16 Frac-N - passes through the A19 Daughterboard	middle connector of A21 YTO Driver	E4423-20514
W39	Semi-Rigid Cable, output of YTO	bottom connector of A21 YTO Driver	E4423-20513
W40	Ribbon Cable, AT1 Electronic Attenuator	A23J25	8121-6837
W41	Semi-Rigid Cable, output of A16 Frac-N	A13 Output - passes through the A19 Daughterboard	E4400-60623
W42 (E4438C)	Semi-Rigid Cable, output of A13 Output	COH CARRIER of the rear panel - passes through the A19 Daughterboard	E4400-60624
W43	Semi-Rigid Cable, output of A13 Output	input of AT1 Electronic Attenuator - passes through the A19 Daughterboard	E4400-60625
W44	Semi-Rigid Cable, output of A18 Reference	A15 Sampler - passes through the A19 Daughterboard	E4400-60626
When using the AT1 High-Power Mechanical Attenuator (Option UNB) with the A28 Reverse Power Protection			
W47	Semi-Rigid Cable, output of A13 Output	input of AT1 High-Power Mechanical Attenuator - passes through A19 Daughterboard	E4400-60627
W48	Semi-Rigid Cable, AT1 High-Power Mechanical Attenuator	input of A28 Reverse Power Protection	E4400-20550

Cables for Option UNJ Signal Generators

Table 2-13

Reference Designator	Input	Output	Part Number
W49	Semi-Rigid Cable, A28 Reverse Power Protection	RF OUTPUT of the rear panel	E4400-20551
W53	wire-harness, control lines of the A28 Reverse Power Protection	A23J22	08647-61028
W57	Ribbon Cable, AT1 High-Power Mechanical Attenuator	A23J25	E4400-20132

Option 1EM Overall Cables - Includes Cables for Option UN7, 005, and 001/601 or 002/602)

Table 2-14

Reference Designator	Input	Output	Part Number
W10 (Option 001/601 or 002/602 — E4438C)	Ribbon Cable, A7J13	A9J3 (Option 501, 502, 503, 504 with Option 300) or A11J3 (Option UN7) or A25P2	8121-0679
W11	Semi-Rigid Cable, output of A16 Frac-N	input of A15 Sampler - passes through A19 Daughterboard	E4400-60622
W19 (E4438C)	A10J10	Q INT LOW on A19 Daughterboard - refer to the connector diagram located on the daughterboard cover	8121-0641
W20 (E4438C)	A10J9	I INT on A19 Daughterboard - refer to the connector diagram located on the daughterboard cover	8121-0641
W23 (Option UN7 — E4438C)	A11J4	BER DATA IN of the rear panel	8121-0659
W24 (Option UN7 — E4438C)	A11J5	BER CLK IN of the rear panel	8121-0659
W25 (Option UN7 — E4438C)	A11J6	BER GATE IN of the rear panel	8121-0659
W26 (Option 005 — E4438C)	Ribbon Cable, A5 10 GB Hard Drive	A12P3	8121-0685
W27	A21J2	A23J34	8121-0644
W28	A21J3	YTO FM on A19 Daughterboard - refer to the connector diagram located on the daughterboard cover	8121-0645
W29	A21J4	PH LK on A19 Daughterboard - refer to the connector diagram located on the daughterboard cover	8121-0645
W30	A21J5	J1 of YTO Interface board	8121-0683
W31	A23J20	SWEEP OUT of rear panel	8121-0658
W32 (E4438C)	A23J36	A25P4	8121-0678

Table 2-14

Reference Designator	Input	Output	Part Number
W40	Ribbon Cable, AT1 Electronic Attenuator	A23J25	8121-6837
W43	Semi-Rigid Cable, output of A13 Output	input of AT1 Electronic Attenuator - passes through the A19 Daughterboard	E4400-60625
W70 ^a	EXT 1 of the rear panel	EXT 1 of A19 Daughterboard - refer to the connector diagram located on the daughterboard cover	8121-0654
W71 ^a	EXT 2 of the rear panel	EXT 2 of A19 Daughterboard - refer to the connector diagram located on the daughterboard cover	8121-0654
W72 (E4438C)	I IN of the rear panel	A10J7	8121-0652
W73 (E4438C)	Q IN of the rear panel	A10J8	8121-0652
W74 (E4438C)	A10J11	I OUT of the rear panel	8121-0653
W75 (E4438C)	A10J12	Q OUT of the rear panel	8121-0653
W76 (E4438C)	A10J13	I bar OUT of the rear panel	8121-0653
W77 (E4438C)	A10J14	Q bar OUT of the rear panel	8121-0653
W78 (Option 001/601 or 002/602 — E4438C)	A7J800	BASEBAND GEN REF IN of the rear panel	8121-0655
W79	A23J20	SWP OUT of the rear panel	8121-0660
W80 (E4438C)	DATA IN of the rear panel	A23J21	8121-0660
W81 (E4438C)	DATA CLK IN of the rear panel	A23J23	8121-0660
W82 (E4438C)	SYMBOL SYNC IN of the rear panel	A23J24	8121-0660
W83	A19 Daughterboard	LF OUT of the rear panel	8121-0656

Table 2-14

Reference Designator	Input	Output	Part Number
W92 (Option 001/601 or 002/602 — E4438C)	Ribbon Cable, A7J21	A25P1	8121-0690

- a. When comparing cables W70 and W71 between a model with Option 506 and a model with either Option 501, 502, 503, 504, or UNJ, notice that cables W70 and W71 are connected to different (swapped) ports of the A19 Daughterboard.

Option 1EM Semi-Rigid Cables - Includes the A21 YTO Driver and the AT1 Electronic Attenuator or the AT1 High-Power Mechanical Attenuator (Option UNB) with A28 Reverse Power Protection

Table 2-15

Reference Designator	Input	Output	Part Number
W11	Semi-Rigid Cable, output of A16 Frac-N	input of A15 Sampler - passes through A19 Daughterboard	E4400-60622
W32 (E4438C)	A23J36	A25P4	8121-0678
W37	Semi-Rigid Cable, A15 Sampler - passes through the A19 Daughterboard	top connector of A21 YTO Driver	E4423-20510
W38	Semi-Rigid Cable, A16 Frac-N - passes through the A19 Daughterboard	middle connector of A21 YTO Driver	E4423-20514
W39	Semi-Rigid Cable, output of YTO	bottom connector of A21 YTO Driver	E4423-20513
W40	Ribbon Cable, AT1 Electronic Attenuator	A23J25	8121-6837
W41	Semi-Rigid Cable, output of A16 Frac-N	A13 Output - passes through the A19 Daughterboard	E4400-60623
W43	Semi-Rigid Cable, output of A13 Output	input of AT1 Electronic Attenuator - passes through the A19 Daughterboard	E4400-60625
W44	Semi-Rigid Cable, output of A18 Reference	A15 Sampler - passes through the A19 Daughterboard	E4400-60626
W47	Semi-Rigid Cable, output of A13 Output	input of AT1 High-Power Mechanical Attenuator - passes through the A19 Daughterboard	E4400-60627
W48	Semi-Rigid Cable, AT1 High-Power Mechanical Attenuator	input of A28 Reverse Power Protection	E4400-20550
W53	wire-harness, control lines of the A28 Reverse Power Protection	A23J22	08647-61028
W57	Ribbon Cable, AT1 High-Power Mechanical Attenuator	A23J25	E4400-20132
W79	A23J20	SWP OUT of the rear panel	8121-0660

Table 2-15

Reference Designator	Input	Output	Part Number
W84 (E4438C)	Semi-Rigid Cable, output of A13 Output	COH CARRIER of rear panel - passes through the A19 Daughterboard	E4400-60631
W85	Semi-Rigid Cable, output of AT1 Electronic Attenuator	RF OUTPUT of the rear panel	E4400-20555
W86	Semi-Rigid Cable, A28 Reverse Power Protection	RF OUTPUT of rear panel	E4400-20552

Cables for Option 506 Signal Generators

Overall Cables - Includes Cables for Option UN7, 005, and 001/601 or 002/602

Table 2-16

Reference Designator	Input	Output	Part Number
W1 (E4438C)	I INPUT of front panel	A10J7	8121-0642
W2 (E4438C)	Q INPUT of front panel	A10J8	8121-0642
W3 (E4438C)	DATA of front panel	A21J21	8121-0661
W4 (E4438C)	DATA CLOCK of front panel	A23J23	8121-0661
W5 (E4438C)	SYMBOL SYNC of front panel	A23J24	8121-0661
W6 ^a	EXT 1 INPUT of front panel	EXT1 on A19 Daughterboard - refer to the connector diagram located on the daughterboard cover	8121-0644
W7 ^a	EXT 2 INPUT of front panel	EXT2 on A19 Daughterboard - refer to the connector diagram located on the daughterboard cover	8121-0644
W8	LF OUTPUT of front panel	LF OUT A19 Daughterboard - refer to the connector diagram located on the daughterboard cover	8121-0657
W10 (Option 001/601 or 002/602 — E4438C)	Ribbon Cable, A7J13	A9J3 (Option 501, 502, 503, 504 with Option 300) or A11J3 (Option UN7) or A25P2	8121-0679
W11	Semi-Rigid Cable, output of A16 Frac-N	input of A15 Sampler - passes through A19 Daughterboard	E4400-60622
W12 (Option 001/601 or 002/602 — E4438C)	A7J800	BASEBAND GEN REF IN of the rear panel	8121-0643
W15 (E4438C)	A10J14	Q bar OUT of the rear panel	8121-0640
W16 (E4438C)	A10J13	I bar OUT of the rear panel	8121-0640

Table 2-16

Reference Designator	Input	Output	Part Number
W17 (E4438C)	A10J12	Q OUT of the rear panel	8121-0640
W18 (E4438C)	A10J11	I OUT of the rear panel	8121-0640
W19 (E4438C)	A10J10	Q INT LOW on A19 Daughterboard - refer to the connector diagram located on the daughterboard cover	8121-0641
W20 (E4438C)	A10J9	I INT on A19 Daughterboard - refer to the connector diagram located on the daughterboard cover	8121-0641
W21 (E4438C)	A10J6	Q INT HIGH on A19 Daughterboard - refer to the connector diagram located on the daughterboard cover	8121-0641
W22 (E4438C)	A10J5	I INT HIGH on A19 Daughterboard - refer to the connector diagram located on the daughterboard cover	8121-0641
W23 (Option UN7 — E4438C)	A11J4	BER DATA IN of the rear panel	8121-0659
W24 (Option UN7 — E4438C)	A11J5	BER CLK IN of the rear panel	8121-0659
W25 (Option UN7 — E4438C)	A11J6	BER GATE IN of the rear panel	8121-0659
W26 (Option 005 — E4438C)	Ribbon Cable, A5 10 GB Hard Drive	A12P3	8121-0685
W27	A21J2	A23J34	8121-0644
W28	A21J3	YTO FM on A19 Daughterboard - refer to the connector diagram located on the daughterboard cover	8121-0645
W29	A21J4	PH LK on A19 Daughterboard - refer to the connector diagram located on the daughterboard cover	8121-0645
W30	A21J5	J1 of YTO Interface board	8121-0683

Cables for Option 506 Signal Generators

Table 2-16

Reference Designator	Input	Output	Part Number
W31	A23J20	SWEEP OUT of rear panel	8121-0658
W32 (E4438C)	A23J36	A25P4	8121-0678
W50	Semi-Rigid Cable, output of A14 Extended Frequency Output	input of AT1 High-Power Mechanical Attenuator - passes through the A19 Daughterboard	E4400-60628
W57	Ribbon Cable, AT1 High-Power Mechanical Attenuator	A23J25	E4400-20132
W58	Semi-Rigid Cable, output of A13 Output	input of A14 Extended Frequency Output - passes through the A19 Daughterboard	E4400-60630
W92 (Option 001/601 or 002/602 — E4438C)	Ribbon Cable, A7J21	A25P1	8121-0690

- a. When comparing cables W6 and W7 between a model with Option 506 and a model with either Option 501, 502, 503, 504, or UNJ, notice that cables W6 and W7 are connected to different (swapped) ports of the A19 Daughterboard.

Front Panel Cables

Table 2-17

Reference Designator	Input	Output	Part Number
W1 (E4438C)	I INPUT of front panel	A10J7	8121-0642
W2 (E4438C)	Q INPUT of front panel	A10J8	8121-0642
W3 (E4438C)	DATA of front panel	A21J21	8121-0661
W4 (E4438C)	DATA CLOCK of front panel	A23J23	8121-0661
W5 (E4438C)	SYMBOL SYNC of front panel	A23J24	8121-0661
W6 ^a	EXT 1 INPUT of front panel	EXT1 on A19 Daughterboard - refer to the connector diagram located on the daughterboard cover	8121-0644
W7 ^a	EXT 2 INPUT of front panel	EXT2 on A19 Daughterboard - refer to the connector diagram located on the daughterboard cover	8121-0644
W8	LF OUTPUT of front panel	LF OUT A19 Daughterboard - refer to the connector diagram located on the daughterboard cover	8121-0657

- a. When comparing cables W6 and W7 between a model with Option 506 and a model with either Option 501, 502, 503, 504, or UNJ, notice that cables W6 and W7 are connected to different (swapped) ports of the A19 Daughterboard.

Standard Cables - Does Not Include Cables for the Front Panel, Option UN7, or Option 005

Table 2-18

Reference Designator	Input	Output	Part Number
W10 (Option 001/601 or 002/602 — E4438C)	Ribbon Cable, A7J13	A9J3 (Option 501, 502, 503, 504 with Option 300) or A11J3 (Option UN7) or A25P2	8121-0679
W11	Semi-Rigid Cable, output of A16 Frac-N	input of A15 Sampler - passes through A19 Daughterboard	E4400-60622
W12 (Option 001/601 or 002/602 — E4438C)	A7J800	BASEBAND GEN REF IN of the rear panel	8121-0643
W15 (E4438C)	A10J14	Q bar OUT of the rear panel	8121-0640
W16 (E4438C)	A10J13	I bar OUT of the rear panel	8121-0640
W17 (E4438C)	A10J12	Q OUT of the rear panel	8121-0640
W18 (E4438C)	A10J11	I OUT of the rear panel	8121-0640
W19 (E4438C)	A10J10	Q INT LOW on A19 Daughterboard - refer to the connector diagram located on the daughterboard cover	8121-0641
W20 (E4438C)	A10J9	I INT on A19 Daughterboard - refer to the connector diagram located on the daughterboard cover	8121-0641
W21 (E4438C)	A10J6	Q INT HIGH on A19 Daughterboard - refer to the connector diagram located on the daughterboard cover	8121-0641
W22 (E4438C)	A10J5	I INT HIGH on A19 Daughterboard - refer to the connector diagram located on the daughterboard cover	8121-0641
W27	A21J2	A23J34	8121-0644
W28	A21J3	YTO FM on A19 Daughterboard - refer to the connector diagram located on the daughterboard cover	8121-0645

Table 2-18

Reference Designator	Input	Output	Part Number
W29	A21J4	PH LK on A19 Daughterboard - refer to the connector diagram located on the daughterboard cover	8121-0645
W30	A21J5	J1 of YTO Interface board	8121-0683
W31	A23J20	SWEEP OUT of rear panel	8121-0658
W32 (E4438C)	A23J36	A25P4	8121-0678
W50	Semi-Rigid Cable, output of A14 Extended Frequency Output	input of AT1 High-Power Mechanical Attenuator - passes through the A19 Daughterboard	E4400-60628
W57	Ribbon Cable, AT1 High-Power Mechanical Attenuator	A23J25	E4400-20132
W58	Semi-Rigid Cable, output of A13 Output	input of A14 Extended Frequency Output - passes through the A19 Daughterboard	E4400-60630
W92 (Option 001/601 or 002/602 — E4438C)	Ribbon Cable, A7J21	A25P1	8121-0690

Only Option UN7, 005, and 001/601 or 002/602 Cables

Table 2-19

Reference Designator	Input	Output	Part Number
W10 (Option 001/601 or 002/602 — E4438C)	Ribbon Cable, A7J13	A9J3 (Option 501, 502, 503, 504 with Option 300) or A11J3 (Option UN7) or A25P2	8121-0679
W11	Semi-Rigid Cable, output of A16 Frac-N	input of A15 Sampler - passes through A19 Daughterboard	E4400-60622
W12 (Option 001/601 or 002/602 — E4438C)	A7J800	BASEBAND GEN REF IN of the rear panel	8121-0643
W23 (Option UN7 — E4438C)	A11J4	BER DATA IN of the rear panel	8121-0659
W24 (Option UN7 — E4438C)	A11J5	BER CLK IN of the rear panel	8121-0659
W25 (Option UN7 — E4438C)	A11J6	BER GATE IN of the rear panel	8121-0659
W26 (Option 005 — E4438C)	Ribbon Cable, A5 10 GB Hard Drive	A12P3	8121-0685
W92 (Option 001/601 or 002/602 — E4438C)	Ribbon Cable, A7J21	A25P1	8121-0690

Semi-Rigid Cables - Includes the A21 YTO Driver and the AT1 High-Power Mechanical Attenuator (Option UNB) with an A29 DC Blocking Capacitor

Table 2-20

Reference Designator	Input	Output	Part Number
W11	Semi-Rigid Cable, output of A16 Frac-N	input of A15 Sampler - passes through A19 Daughterboard	E4400-60622
W31	A23J20	SWEEP OUT of rear panel	8121-0658
W32 (E4438C)	A23J36	A25P4	8121-0678
W37	Semi-Rigid Cable, A15 Sampler - passes through the A19 Daughterboard	top connector of A21 YTO Driver	E4423-20510
W38	Semi-Rigid Cable, A16 Frac-N - passes through the A19 Daughterboard	middle connector of A21 YTO Driver	E4423-20514
W41	Semi-Rigid Cable, output of A16 Frac-N	A13 Output - passes through the A19 Daughterboard	E4400-60623
W42 (E4438C)	Semi-Rigid Cable, output of A13 Output	COH CARRIER of the rear panel - passes through the A19 Daughterboard	E4400-60624
W44	Semi-Rigid Cable, output of A18 Reference	A15 Sampler - passes through the A19 Daughterboard	E4400-60626
W50	Semi-Rigid Cable, output of A14 Extended Frequency Output	input of AT1 High-Power Mechanical Attenuator - passes through the A19 Daughterboard	E4400-60628
W54	Semi-Rigid Cable, output of YTO	A22 Coupler	E4400-20560
W55	Semi-Rigid Cable, output of A22 Coupler	bottom connector of A21 YTO Driver	E4400-20561
W56	Semi-Rigid Cable, coupled output of A22 Coupler	input of A14 Extended Frequency Output - passes through A19 Daughterboard	E4400-60629
W57	Ribbon Cable, AT1 High-Power Mechanical Attenuator	A23J25	E4400-20132
W58	Semi-Rigid Cable, output of A13 Output	input of A14 Extended Frequency Output - passes through the A19 Daughterboard	E4400-60630

Cables for Option 506 Signal Generators

Table 2-20

Reference Designator	Input	Output	Part Number
W59	Semi-Rigid Cable, output of AT1 High-Power Mechanical Attenuator	input of A29 DC Blocking Capacitor	E4400-20573
W60	connector, output of A29 DC Blocking Capacitor (Option 506)	input of RF OUPUT	1250-1249

Option 1EM Overall Cables - Includes Cables for Option UN7, 005, and 001/601 or 002/602

Table 2-21

Reference Designator	Input	Output	Part Number
W10 (Option 001/601 or 002/602 — E4438C)	Ribbon Cable, A7J13	A9J3 (Option 501, 502, 503, 504 with Option 300) or A11J3 (Option UN7) or A25P2	8121-0679
W11	Semi-Rigid Cable, output of A16 Frac-N	input of A15 Sampler - passes through A19 Daughterboard	E4400-60622
W19 (E4438C)	A10J10	Q INT LOW on A19 Daughterboard - refer to the connector diagram located on the daughterboard cover	8121-0641
W20 (E4438C)	A10J9	I INT on A19 Daughterboard - refer to the connector diagram located on the daughterboard cover	8121-0641
W21 (E4438C)	A10J6	Q INT HIGH on A19 Daughterboard - refer to the connector diagram located on the daughterboard cover	8121-0641
W22 (E4438C)	A10J5	I INT HIGH on A19 Daughterboard - refer to the connector diagram located on the daughterboard cover	8121-0641
W23 (Option UN7 — E4438C)	A11J4	BER DATA IN of the rear panel	8121-0659
W24 (Option UN7 — E4438C)	A11J5	BER CLK IN of the rear panel	8121-0659
W25 (Option UN7 — E4438C)	A11J6	BER GATE IN of the rear panel	8121-0659
W26 (Option 005 — E4438C)	Ribbon Cable, A5 10 GB Hard Drive	A12P3	8121-0685
W27	A21J2	A23J34	8121-0644
W28	A21J3	YTO FM on A19 Daughterboard - refer to the connector diagram located on the daughterboard cover	8121-0645

Table 2-21

Reference Designator	Input	Output	Part Number
W29	A21J4	PH LK on A19 Daughterboard - refer to the connector diagram located on the daughterboard cover	8121-0645
W30	A21J5	J1 of YTO Interface board	8121-0683
W31	A23J20	SWEEP OUT of rear panel	8121-0658
W32 (E4438C)	A23J36	A25P4	8121-0678
W50	Semi-Rigid Cable, output of A14 Extended Frequency Output	input of AT1 High-Power Mechanical Attenuator - passes through the A19 Daughterboard	E4400-60628
W57	Ribbon Cable, AT1 High-Power Mechanical Attenuator	A23J25	E4400-20132
W58	Semi-Rigid Cable, output of A13 Output	input of A14 Extended Frequency Output - passes through the A19 Daughterboard	E4400-60630
W70 ^a	EXT 1 of the rear panel	EXT 1 of A19 Daughterboard - refer to the connector diagram located on the daughterboard cover	8121-0654
W71 ^a	EXT 2 of the rear panel	EXT 2 of A19 Daughterboard - refer to the connector diagram located on the daughterboard cover	8121-0654
W72 (E4438C)	I IN of the rear panel	A10J7	8121-0652
W73 (E4438C)	Q IN of the rear panel	A10J8	8121-0652
W74 (E4438C)	A10J11	I OUT of the rear panel	8121-0653
W75 (E4438C)	A10J12	Q OUT of the rear panel	8121-0653
W76 (E4438C)	A10J13	I bar OUT of the rear panel	8121-0653
W77 (E4438C)	A10J14	Q bar OUT of the rear panel	8121-0653
W78 (Option 001/601 or 002/602 — E4438C)	A7J800	BASEBAND GEN REF IN of the rear panel	8121-0655

Table 2-21

Reference Designator	Input	Output	Part Number
W79	A23J20	SWP OUT of the rear panel	8121-0660
W80 (E4438C)	DATA IN of the rear panel	A23J21	8121-0660
W81 (E4438C)	DATA CLK IN of the rear panel	A23J23	8121-0660
W82 (E4438C)	SYMBOL SYNC IN of the rear panel	A23J24	8121-0660
W83	A19 Daughterboard	LF OUT of the rear panel	8121-0656
W92 (Option 001/601 or 002/602 — E4438C)	Ribbon Cable, A7J21	A25P1	8121-0690

- a. When comparing cables W70 and W71 between a model with Option 506 and a model with either Option 501, 502, 503, 504, or UNJ, notice that cables W70 and W71 are connected to different (swapped) ports of the A19 Daughterboard.

Option 1EM Semi-Rigid Cables - Includes the A21 YTO Driver and the AT1 High-Power Mechanical Attenuator (Option UNB) with an A29 DC Blocking Capacitor

Table 2-22

Reference Designator	Input	Output	Part Number
W11	Semi-Rigid Cable, output of A16 Frac-N	input of A15 Sampler - passes through the A19 Daughterboard	E4400-60622
W32 (E4438C)	A23J36	A25P4	8121-0678
W37	Semi-Rigid Cable, A15 Sampler - passes through the A19 Daughterboard	top connector of A21 YTO Driver	E4423-20510
W38	Semi-Rigid Cable, A16 Frac-N - passes through the A19 Daughterboard	middle connector of A21 YTO Driver	E4423-20514
W41	Semi-Rigid Cable, output of A16 Frac-N	A13 Output - passes through the A19 Daughterboard	E4400-60623
W44	Semi-Rigid Cable, output of A18 Reference	A15 Sampler - passes through the A19 Daughterboard	E4400-60626
W50	Semi-Rigid Cable, output of A14 Extended Frequency Output	input of AT1 High-Power Mechanical Attenuator - passes through the A19 Daughterboard	E4400-60628
W54	output of YTO	A22 Coupler	E4400-20560
W55	Semi-Rigid Cable, output of A22 Coupler	bottom connector of A21 YTO Driver	E4400-20561
W56	Semi-Rigid Cable, coupled output of A22 Coupler	input of A14 Extended Frequency Output - passes through the A19 Daughterboard	E4400-60629
W57	Ribbon Cable, AT1 High-Power Mechanical Attenuator	A23J25	E4400-20132
W58	Semi-Rigid Cable, output of A13 Output	input of A14 Extended Frequency Output - passes through the A19 Daughterboard	E4400-60630
W79	A23J20	SWP OUT of the rear panel	8121-0660
W84 (E4438C)	Semi-Rigid Cable, output of A13 Output	COH CARRIER of rear panel - passes through the A19 Daughterboard	E4400-60631

Table 2-22

Reference Designator	Input	Output	Part Number
W91	Semi-Rigid Cable, output of AT1 High-Power Mechanical Attenuator	input of A29 DC Blocking Capacitor	E4400-20574

Hardware and Other Instrument Parts

This section lists part numbers for hardware and other instrument parts in your signal generator.

- “Front Panel” on page 2-67
- “Disassembled Front Panel” on page 2-69
- “Rear-Panel Hardware” on page 2-72
- “Rear-Panel (Option 1EM)” on page 2-75
- “Disassembled AT1 Electronic Attenuator” on page 2-78
- “Disassembled AT1 High-Power Mechanical Attenuator (Option UNB) and A28 Reverse Power Protection (Option 501, 502, 503, 504 or Option UNJ)” on page 2-79
- “Disassembled AT1 High-Power Mechanical Attenuator (Option 506 Only)” on page 2-81
- “Disassembled A6 Power Supply Shield and Left-Side” on page 2-82
- “Disassembled A23 Motherboard and Bottom-Side” on page 2-83
- “Outside Instrument Covers and Associated Parts” on page 2-84
- “Inside Instrument Covers and Associated Parts” on page 2-86

Front Panel

Table 2-23

Item No.	Description	Qty	Part Number
1	menu overlay (E4428C — Option 503)	1	E4400-80511
	menu overlay (E4428C — Option 506)	1	E4400-80556
	menu overlay (E4438C)	1	E4400-80509
2	menu overlay (E4428C — Option 1EM)	1	E4400-80512
	menu overlay (E4438C — Option 1EM)	1	E4400-80510
3	small overlay-connectors (E4438C)	1	E4400-80006
4	small overlay-connectors (E4428C and Option 1EM)	1	E4400-80011
5	nameplate label 250 kHz to 1 GHz (E4438C — Option 501)	1	E4400-80504
	nameplate label 250 kHz to 2 GHz (E4438C — Option 502)	1	E4400-80505
	nameplate label 250 kHz to 3 GHz (E4428C — Option 503)	1	E4400-80554
	nameplate label 250 kHz to 3 GHz (E4438C — Option 503)	1	E4400-80506
	nameplate label 250 kHz to 4 GHz (E4438C — Option 504)	1	E4400-80507
	nameplate label 250 kHz to 6 GHz (E4428C — Option 506)	1	E4400-80555
	nameplate label 250 kHz to 6 GHz (E4438C — Option 506)	1	E4400-80500
6	knob-RPG	1	E4400-40003
7	hex-nut E4428C	3	2950-0035
	E4438C	8	
8	washer E4428C	3	3050-1919
	E4438C	8	

Figure 2-13 Front Panel

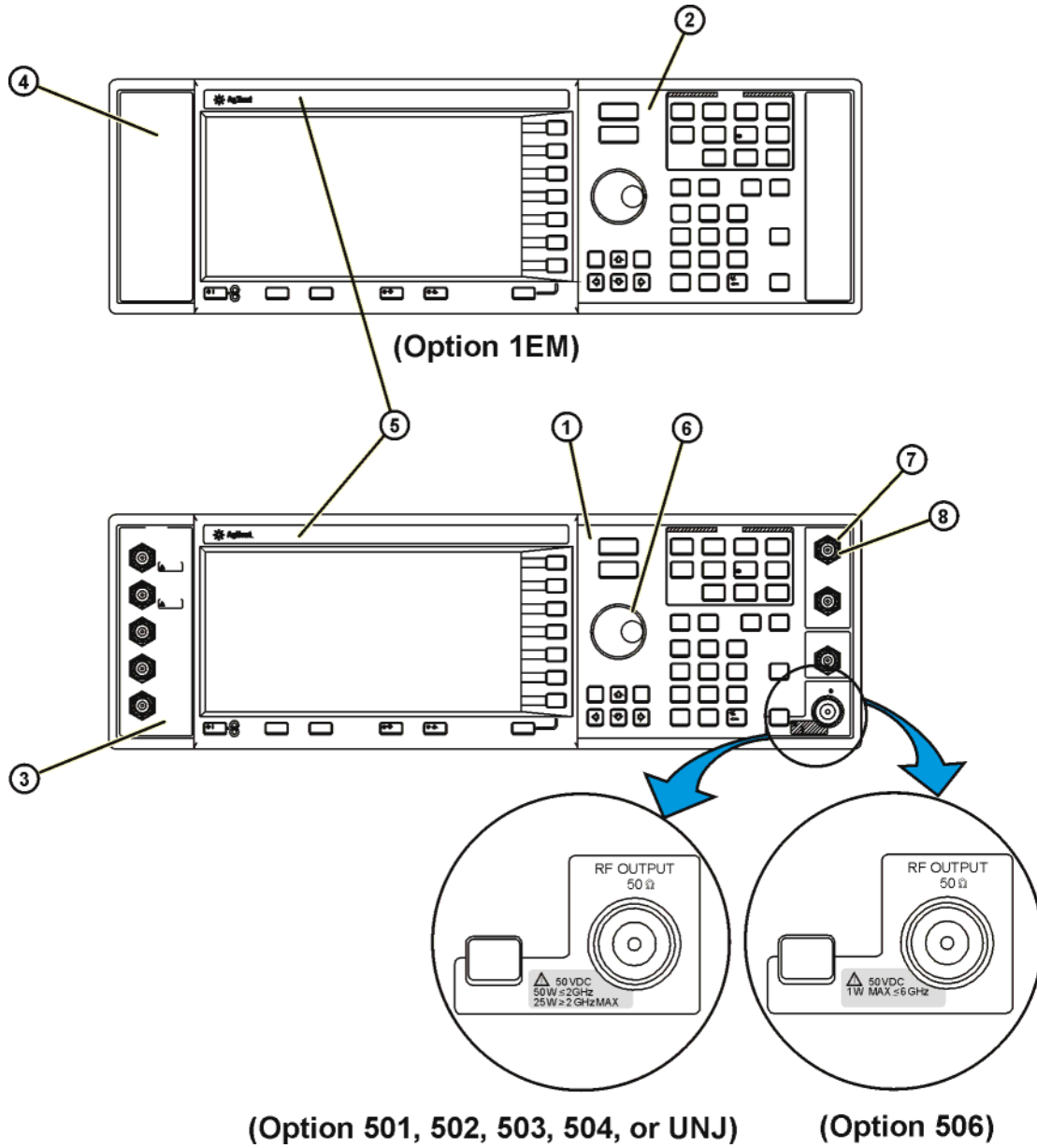

Disassembled Front Panel

Table 2-24

Item No.	Description	Qty	Part Number
1	front panel frame	1	E4400-20522
2	RF OUTPUT connector and bracket	1	E4400-60536
3	screw-machine (flathead screws for RF OUTPUT connector bracket to chassis)	2	0515-1227
4	mesh gasket (frame)	1	8160-7023
5	glass filter	1	4330-1711
6	rubber keypad E4428C (analog) E4438C (vector)	1	E4400-40503 E4400-40502
7	bracket filter	1	E4400-00009
8	screw-machine (flathead screws for filter bracket and front panel board)	14	0515-1227
9	RFI shield	1	E4400-00515
10	screw-machine (pan-head screw for RFI Shield and A2 Display)	12	0515-0372
11	spira gasket (window)	1	8160-0660
12	white-plastic clamp	2	1400-1594
13	plastic clamp	1	1400-2293
14	bracket for A5 Hard Drive (E4438C) <US4426/MY4426 bracket for A5 Hard Drive (E4438C) >= US4426/MY4426	1 1	E4400-00526 E4400-00547
15	bushing for A5 Hard Drive (E4438C)	8	0340-1525
16	screw-machine for A5 Hard Drive Torque to 2.5 in-lb. (E4438C)	4	0515-0681
17	screw-machine A5 Hard Drive to RFI shield, serial prefixes <US4426/MY4426 (E4438C)	4	0515-0664
17	screw-machine A5 Hard Drive to RFI shield, serial prefixes ≥US4426/MY4426 (E4438C)	2	0515-0372
18	screw-machine A3 Front Panel Auxilary Board to RFI shield	1	0515-0372

Figure 2-14 Disassembled Front Panel, for instruments with serial prefixes <US4426/MY4426

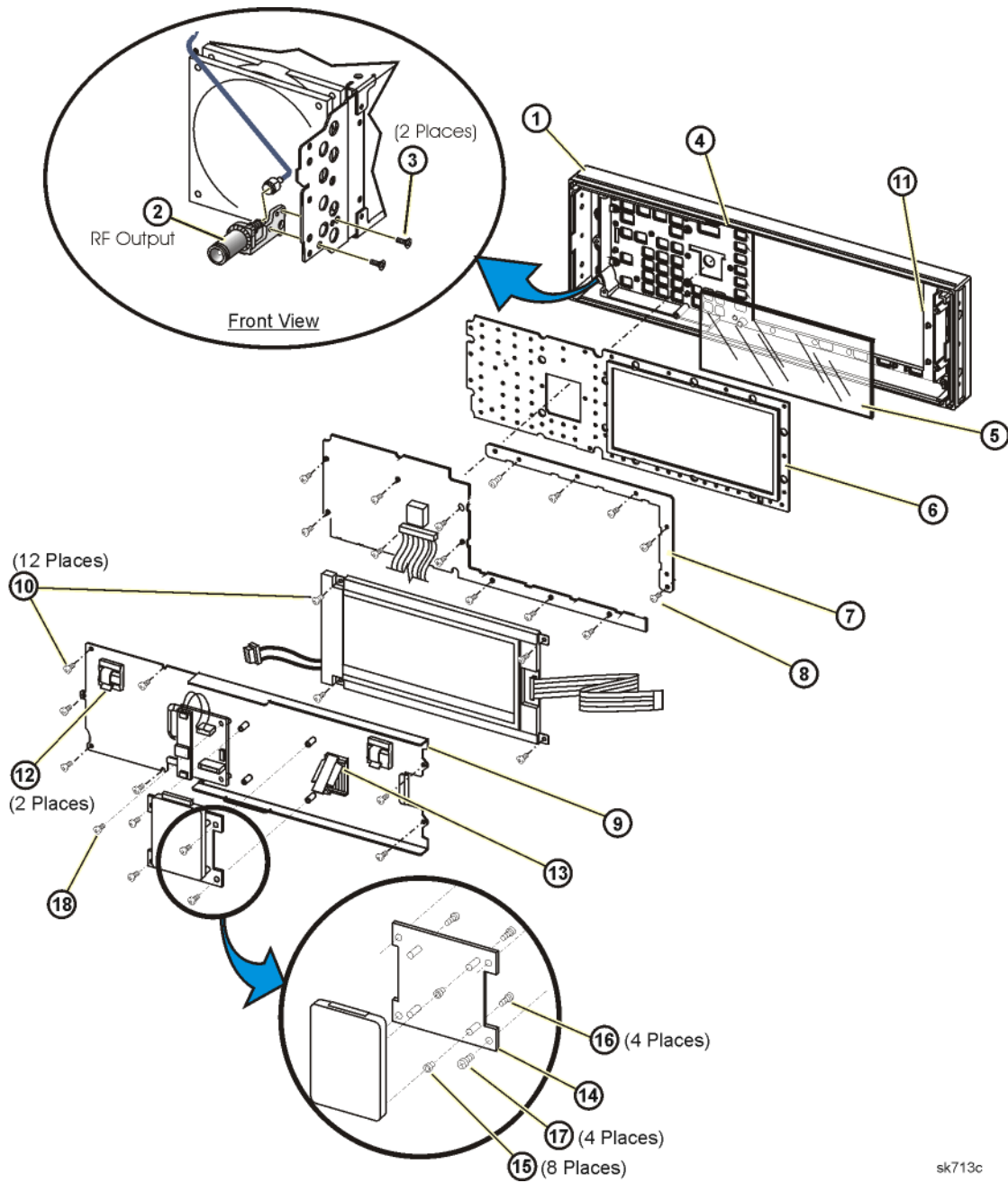
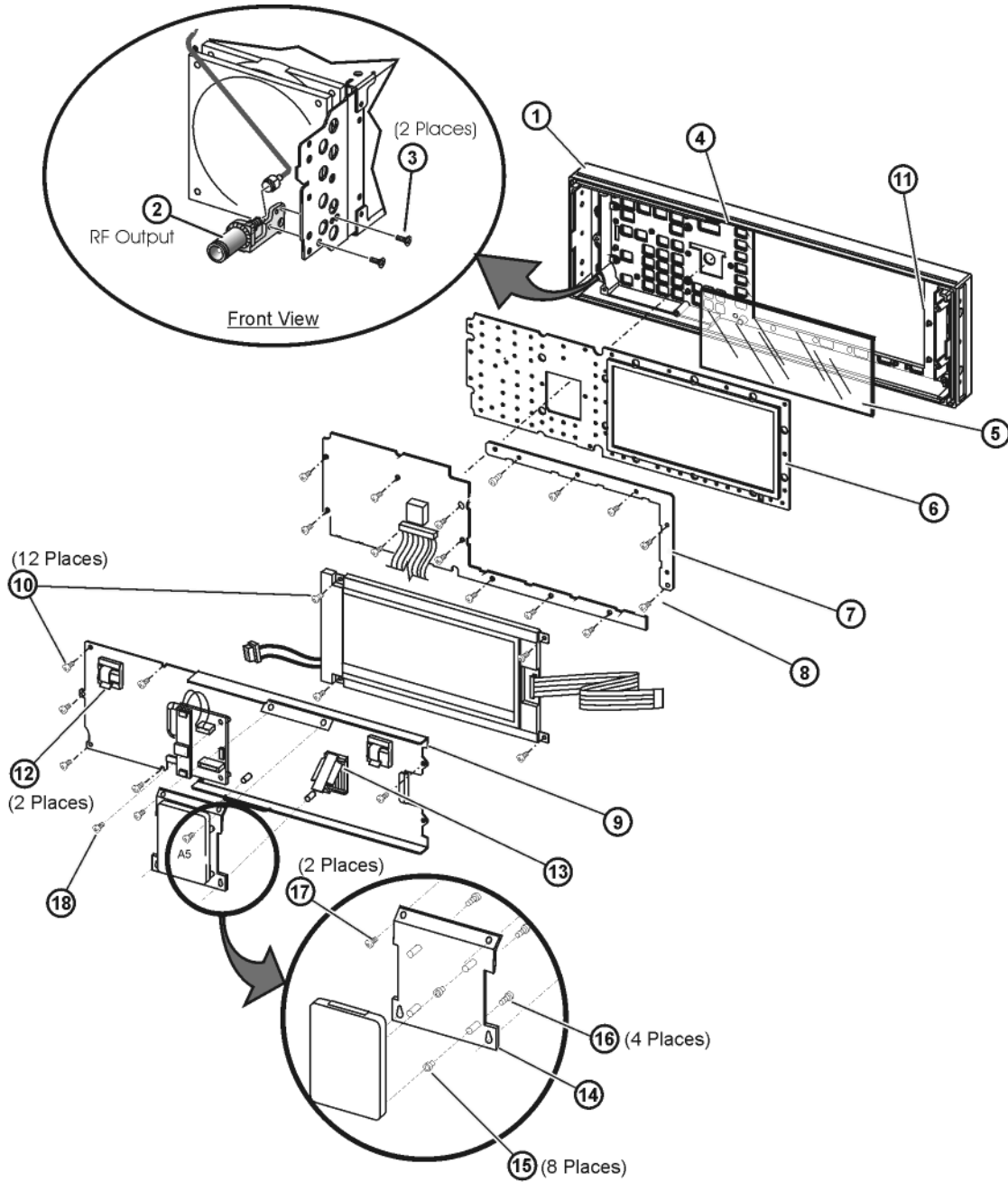

Figure 2-15 Disassembled Front Panel, for instruments with serial prefixes \geq US4426/MY4426



Rear-Panel Hardware**Table 2-25**

Item No.	Description	Qty	Part Number
1	rear panel (E4428C)	1	E4400-00552
	rear panel (E4438C)	1	E4400-00531
2	screw-machine (coherent carrier — E4438C)	1	0515-0372
3	connector (coherent carrier — E4438C)	1	1250-1753
4	dust cap (coherent carrier — E4438C)	1	1250-2759
5	washer (E4428C)	1	2190-0102
	washer (E4438C)	10	
6	hex nut (E4428C)	1	2950-0035
	hex nut (E4438C)	10	
7	washer (Aux I/O connector to rear panel — E4438C)	2	2190-0003
8	screw (Aux I/O connector to rear panel — E4438C)	2	0380-2079
9	screw-machine (DIG BUS connector to rear panel — E4438C)	2	0515-4439
10	washer (BNC connectors from A23 Motherboard)	4	2190-0068
11	hex nut (BNC connector from A23 Motherboard)	4	2950-0054
12	washer (GPIB)	2	2190-0577
13	standoff screw-hex (GPIB)	2	0380-0644
14	washer (RS 232)	2	2190-0003
15	screw (RS 232)	2	0380-2079
16	screw-machine (rear panel to chassis)	8	0515-0372
17	washer (BER DATA IN, BER CLK IN, BER GATE IN, 321.4 IN connectors — E4438C)	3	2190-0124
18	hex nut (BER DATA IN, BER CLK IN, BER GATE IN, 321.4 IN connectors — E4438C)	3	2950-0078

Figure 2-16 E4428C, Rear-Panel Hardware

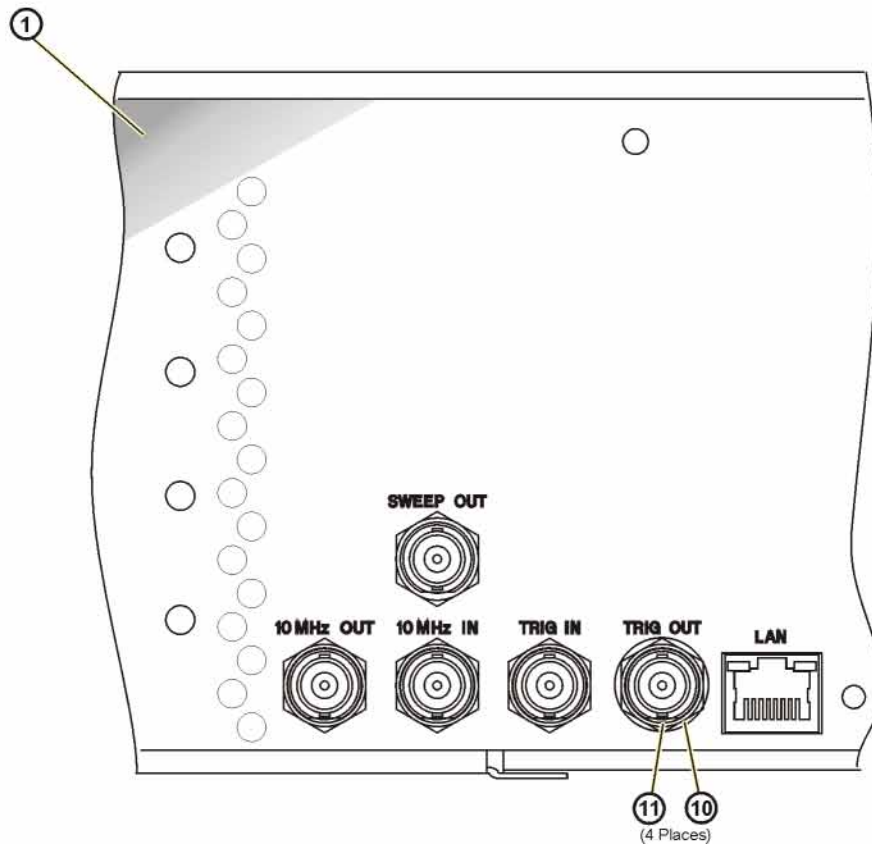
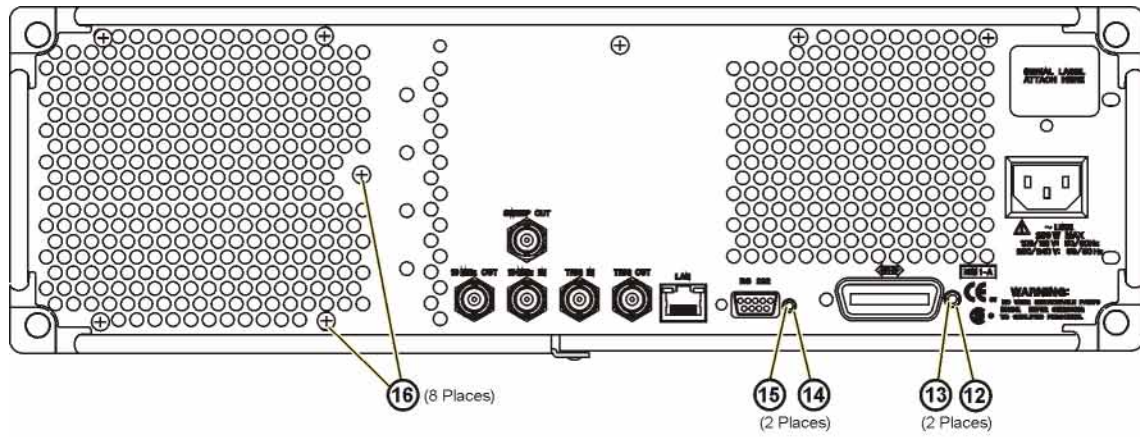
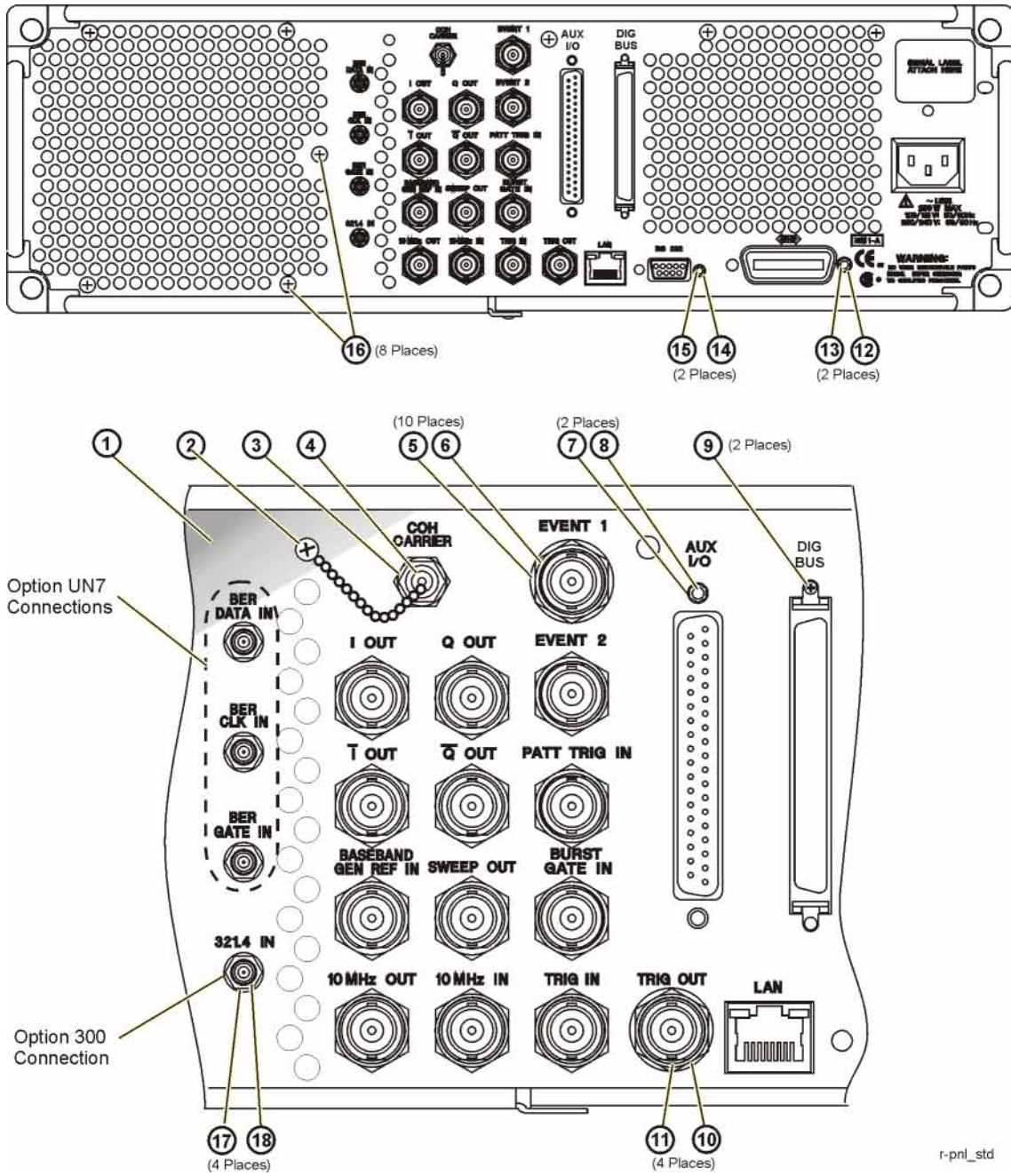

Figure 2-17 E4438C, Rear-Panel Hardware



Rear-Panel (Option 1EM)

Table 2-26

Item No.	Description	Qty	Part Number
1	rear panel (E4428C)	1	E4400-00530
	rear panel (E4438C)	1	E4400-00532
2	RF OUTPUT connector and bracket	1	E4400-60542
3	screw-machine (coherent carrier — E4438C)	1	0515-0372
4	connector (coherent carrier — E4438C)	1	1250-1753
5	dust cap (coherent carrier — E4438C)	1	1250-2759
6	washer (Aux I/O connector to rear panel— E4438C)	2	2190-0003
7	screw (Aux I/O connector to rear panel — E4438C)	2	0380-2079
8	screw-machine (DIG BUS connector to rear panel — E4438C)	2	0515-4439
9	washer (BNC connector) (E4428C)	8	2190-0068
	washer (BNC connector) (E4438C)	4	
10	hex nut (BNC connector) (E4428C)	8	2950-0054
	hex nut (BNC connector) (E4438C)	4	
11	washer (RS-232 connector)	2	2190-0003
12	screw-machine (RS-232 connector)	2	0380-2079
13	washer (GPIB connector)	2	2190-0577
14	standoff screw-hex (GPIB connector)	2	0380-0644
15	washer (BER DATA IN, BER CLK IN, BER GATE IN, 321.4 IN connectors — E4438C)	4	2190-0124
16	hex nut (BER DATA IN, BER CLK IN, BER GATE IN, 321.4 IN connectors — E4438C)	4	2950-0078
17	washer (E4438C)	18	2190-0102
18	hex nut (E4438C)	18	2950-0035
19	screw-machine (rear panel to chassis)	8	0515-0372

Figure 2-18 E4428C,Rear-Panel (Option 1EM)

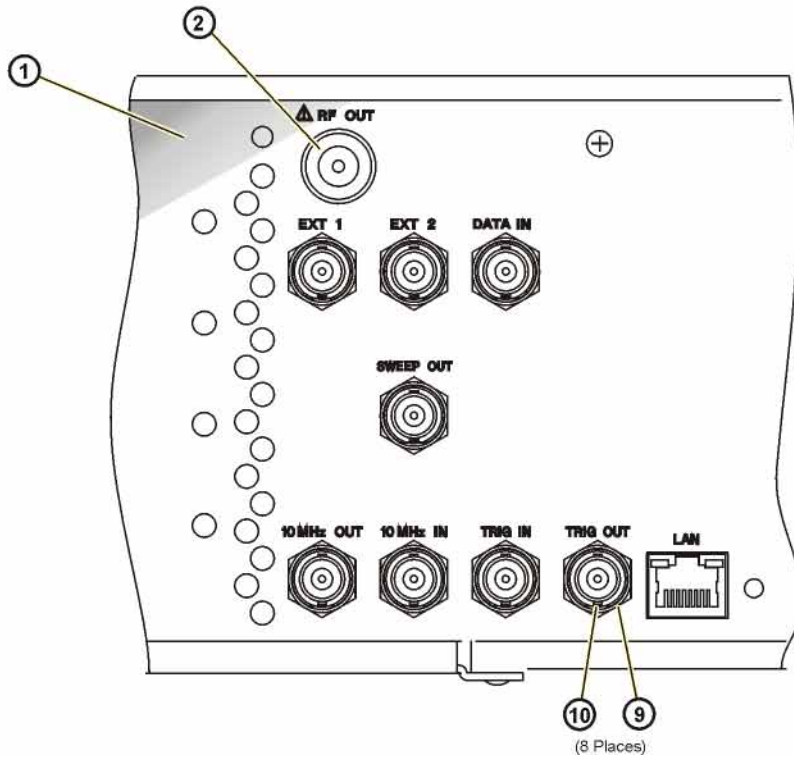
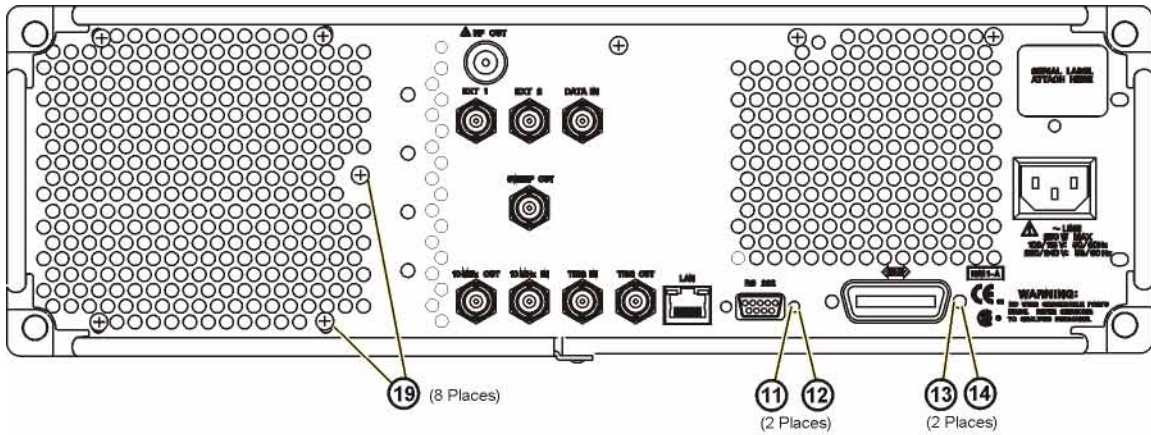
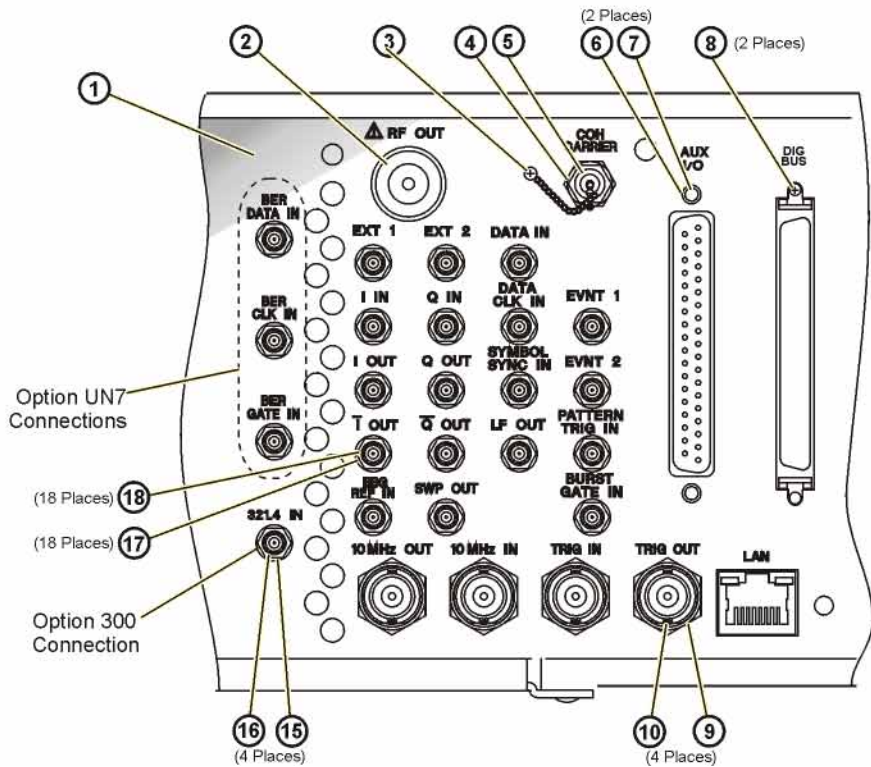
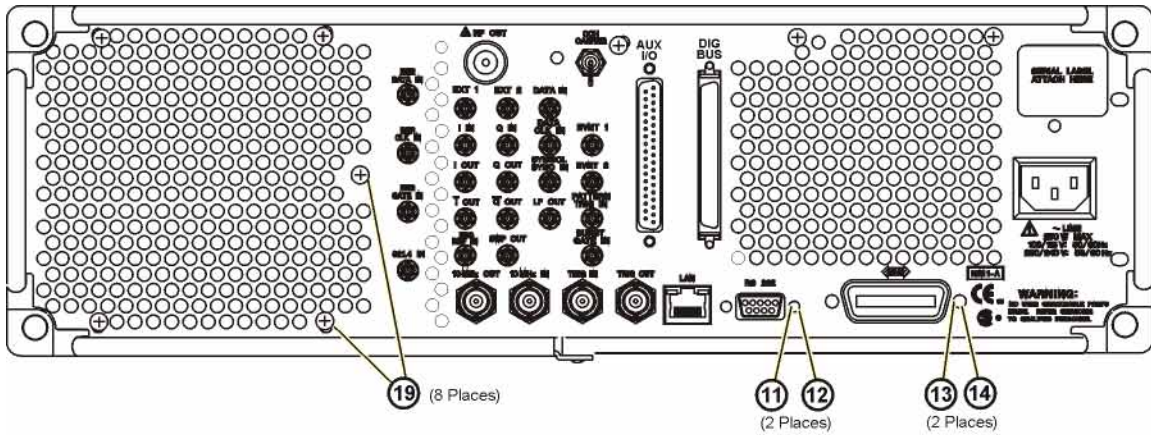

Figure 2-19 E4438C,Rear-Panel (Option 1EM)



r-pnl_1em

Disassembled AT1 Electronic Attenuator

Table 2-27

Item No.	Description	Qty	Part Number
1	bracket for AT1 Electronic Attenuator	1	E4400-00523
2	screw-machine (pan head screw used to attach the AT1 Electronic Attenuator bracket to the chassis)	2	0515-0433
3	screw-machine (flathead screw used to attach the AT1 Electronic Attenuator to the AT1 Electronic Attenuator bracket)	3	0515-0664

Figure 2-20 Disassembled AT1 Electronic Attenuator

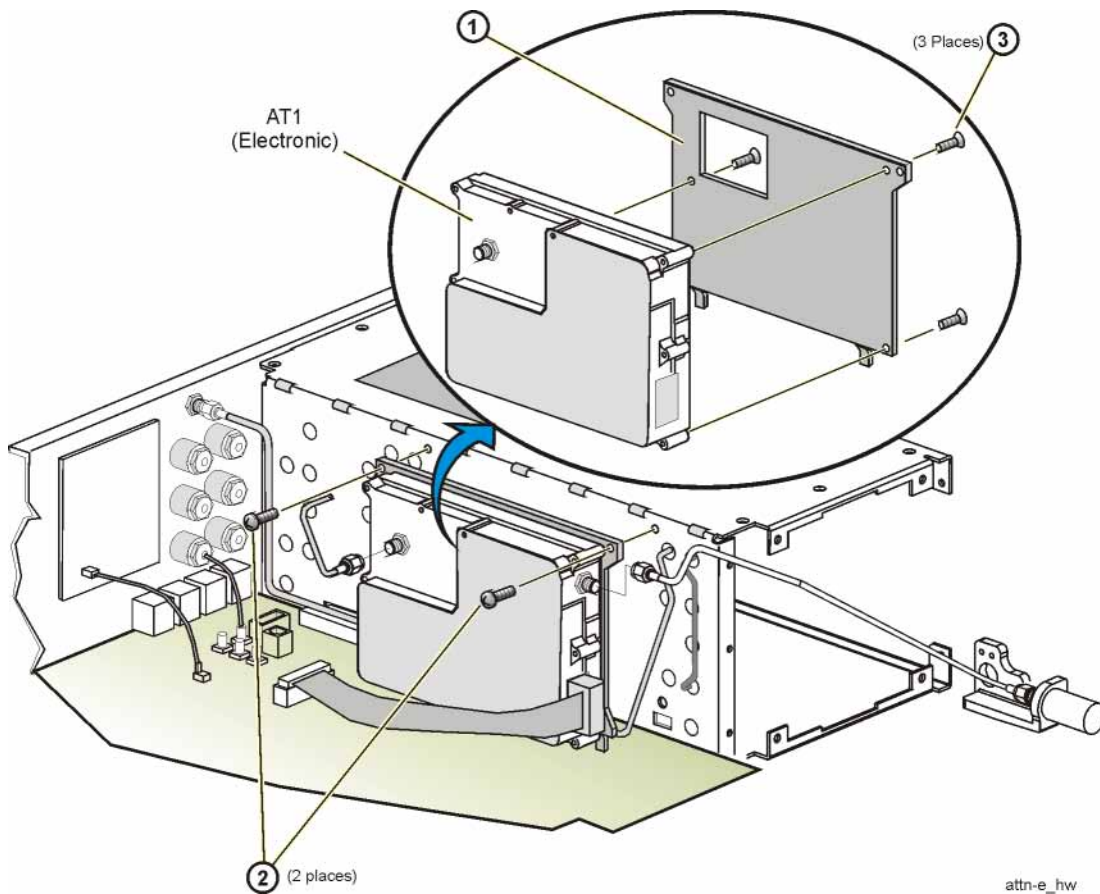

**Disassembled AT1 High-Power Mechanical Attenuator (Option UNB)
and A28 Reverse Power Protection (Option 501, 502, 503, 504 or Option UNJ)**

Table 2-28

Item No.	Description	Qty	Part Number
1	bracket for AT1 High-Power Mechanical Attenuator (Option UNB)	1	E4400-00523
2	bracket for A28 Reverse Power Protection (Option 501, 502, 503, 504 or Option UNJ)	1	E4400-00524
3	screw-machine (flathead screw used to attach the AT1 Mechanical Attenuator to AT1 Mechanical Attenuator bracket)	2	0515-1227
4	screw-machine (flathead screw used to attach the AT1 Mechanical Attenuator bracket to the A28 RPP bracket)	4	0515-0664
5	screw-machine (flathead screw used to attach the A28 RPP to the A28 RPP bracket)	4	0515-0664
6	screw-machine (pan head screw used to attach the AT1 Mechanical Attenuator and A28 RPP to the chassis)	2	0515-0430

Figure 2-21 Disassembled AT1 High-Power Mechanical Attenuator and A28 Reverse Power Protection

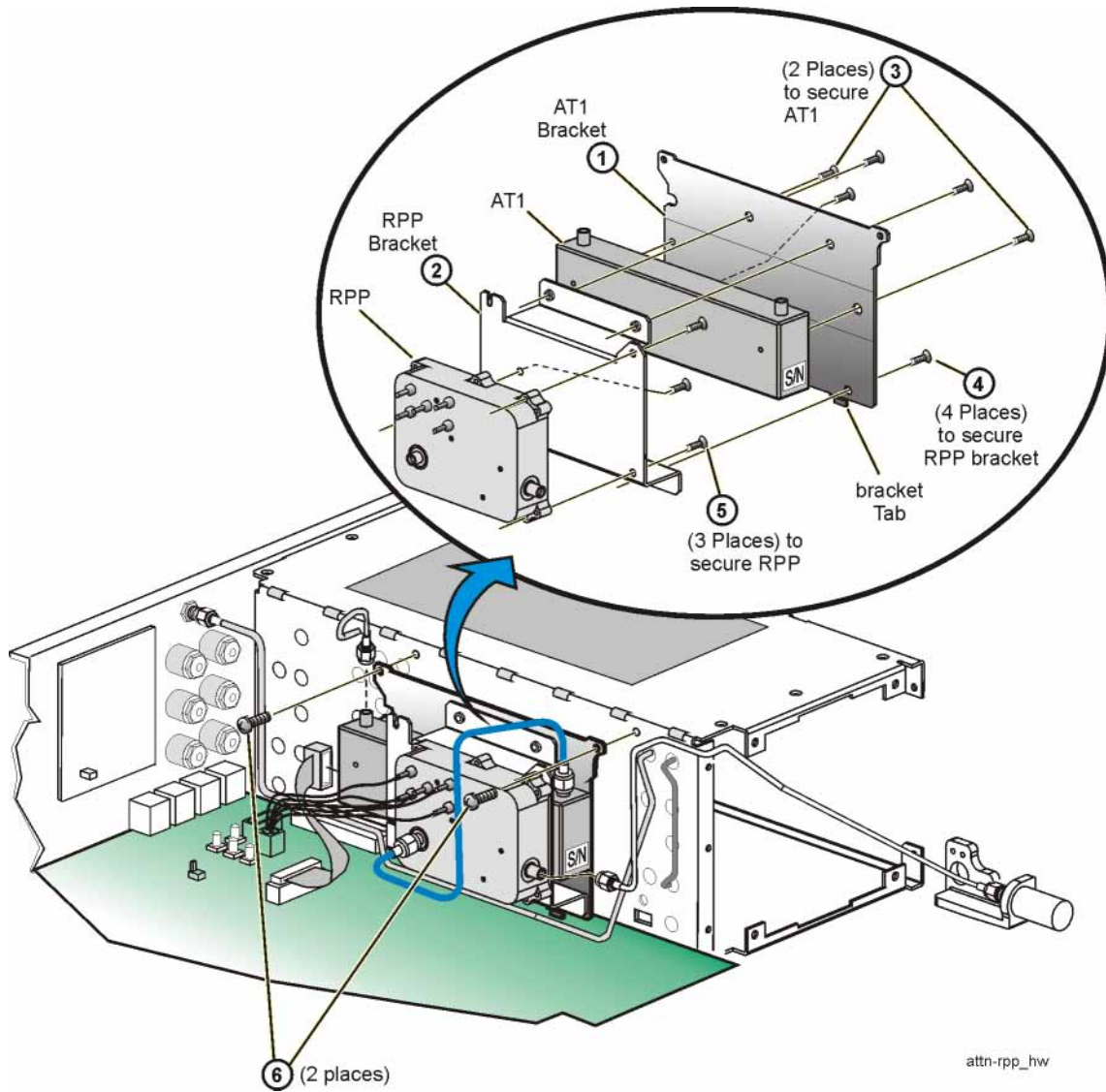

Disassembled AT1 High-Power Mechanical Attenuator (Option 506 Only)

Table 2-29

Item No.	Description	Qty	Part Number
1	bracket for AT1 High-Power Mechanical Attenuator (Option UNB)	1	E4400-00523
2	screw-machine (pan head screw used to attach the AT1 Mechanical Attenuator bracket to chassis)	2	0515-1227
3	screw-machine (flathead screw to hold the AT1 Mechanical Attenuator to the AT1 Mechanical Attenuator bracket)	2	0515-0664

Figure 2-22 Disassembled AT1 High-Power Mechanical Attenuator (Option 506 Only)

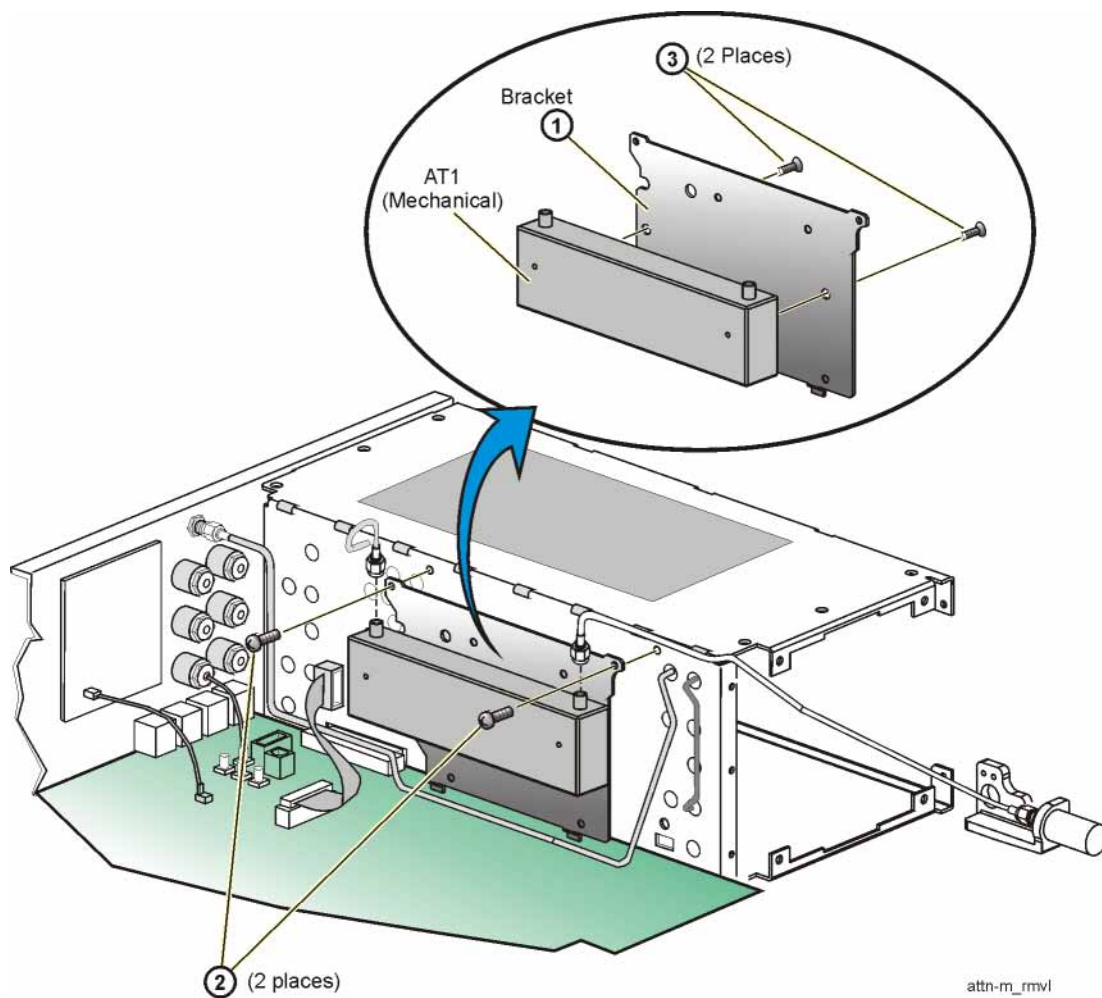

Disassembled A6 Power Supply Shield and Left-Side

Table 2-30

Item No.	Description	Qty	Part Number
1	screw-machine M4 x 10 FL-TX	3	0515-1269
2	screw-machine	10	0515-0372
3	shield for A6 Power Supply	1	E4400-00512

Figure 2-23 Disassembled A6 Power Supply Shield and Left-Side

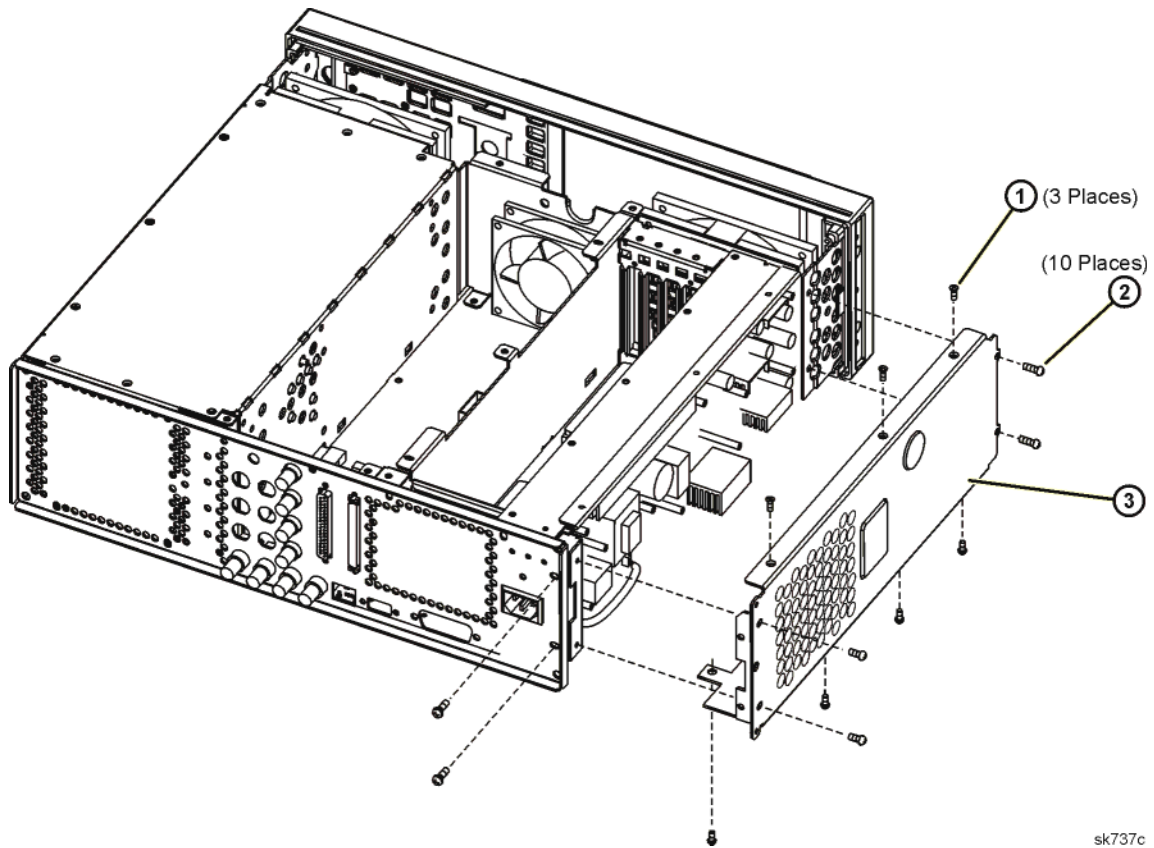

Disassembled A23 Motherboard and Bottom-Side

Table 2-31

Item No.	Description	Qty	Part Number
1	screw-machine M3 x 8 CW-PN-TX	9	0515-0372
2	bottom rib-bracket	1	E4400-00527

Figure 2-24 Disassembled A23 Motherboard and Bottom-Side

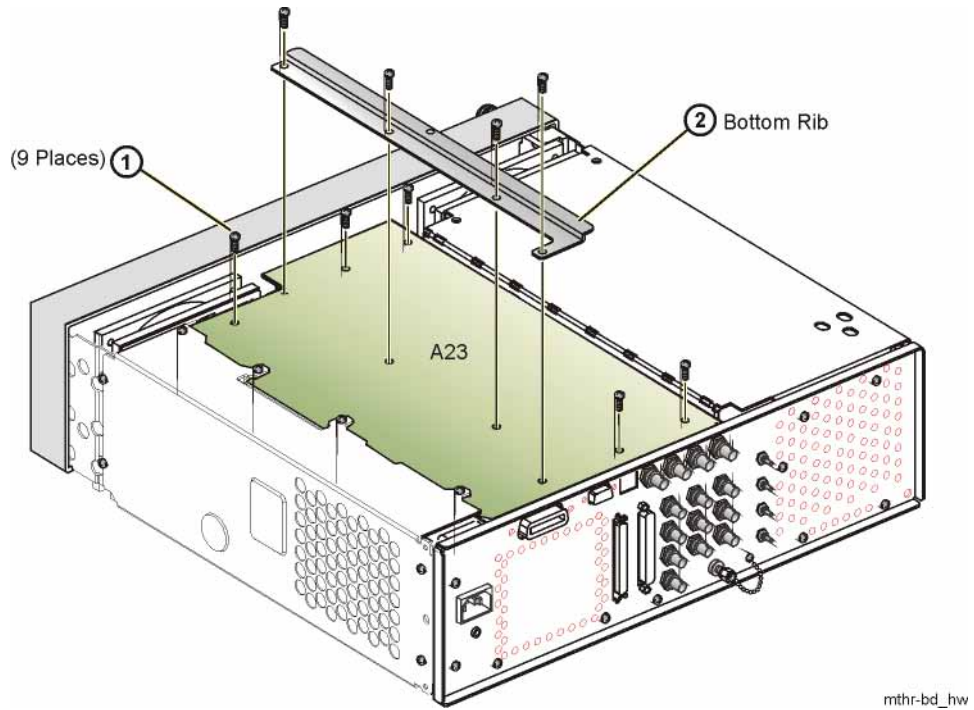

Outside Instrument Covers and Associated Parts**Table 2-32**

Item No.	Description	Qty	Part Number
1	Kit includes the following parts:	Kit	E4400-60026
	assembly-strap handle	2	
	strap assembly	2	
	ground spring	4	
	handle retainer	4	
	end cap	4	
	screw-machine M5 x 18 FL-TX	4	
2	feet-bottom	2	5041-9167
3	feet-bottom screws	4	0515-1619
4	outside instrument cover	1	E4400-00553
5	feet-rear	4	5041-9611
6	tilt stand	2	1460-1345
7	key lock (not shown in drawing)	4	5021-2840

Figure 2-25 Outside Instrument Covers and Associated Parts

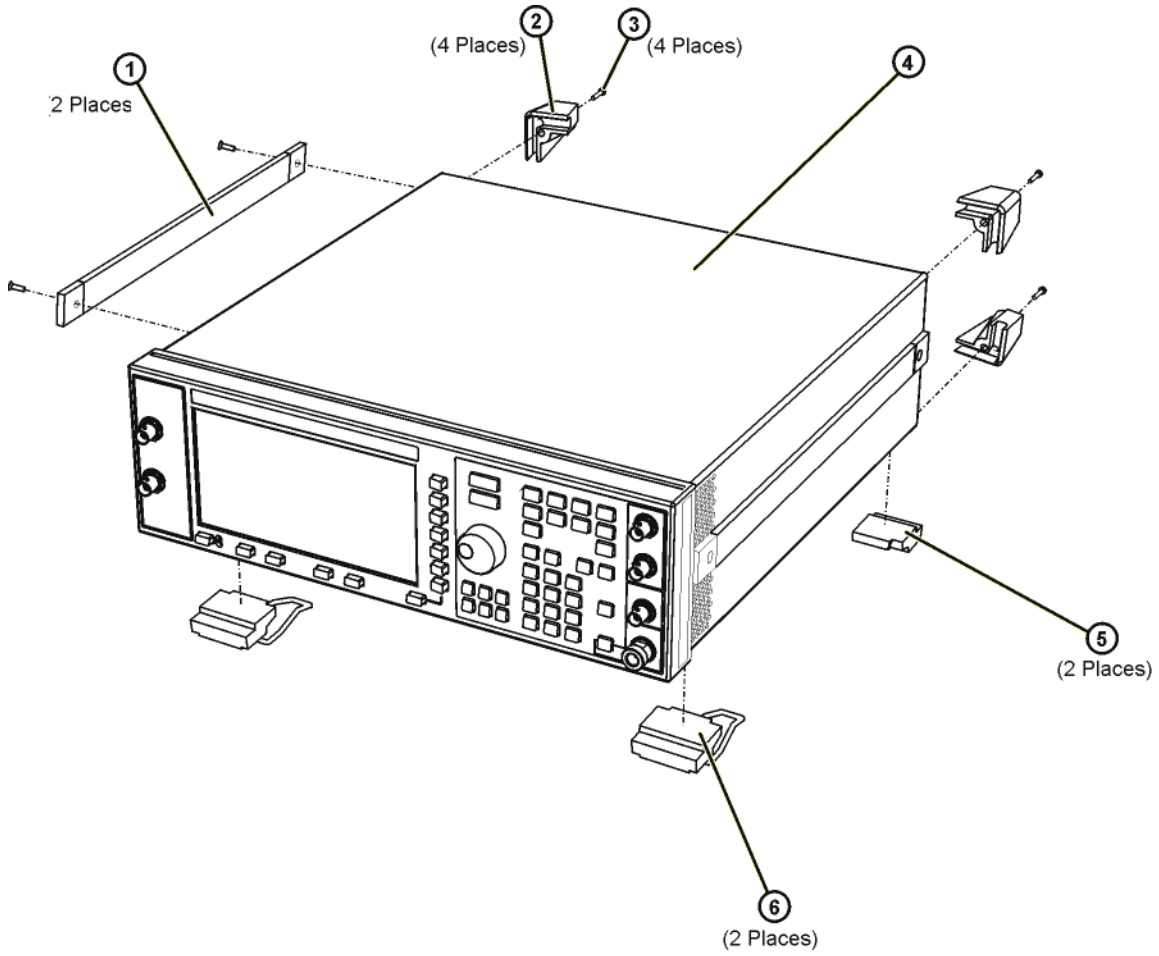

sk739c

Inside Instrument Covers and Associated Parts

Table 2-33

Item No.	Description	Qty	Part Number
1	label-connection diagram (Option 501, 502, 503, 504)	1	E4400-80513
	label-connection diagram (Option 300)	1	E4400-80514
	label-connection diagram (Option UNJ)	1	E4400-80501
2	chassis	1	E4400-60538
3	screw-machine (pan head screw used to attach inside-cover-side to chassis)	4	0515-0287
4	inside cover-side	1	E4400-00514
5	screw-machine (flathead screw used to attach inside cover-top to chassis)	10	0515-0430
6	inside cover-top	1	E4400-00513

Figure 2-26 Inside Instrument Covers and Associated Parts

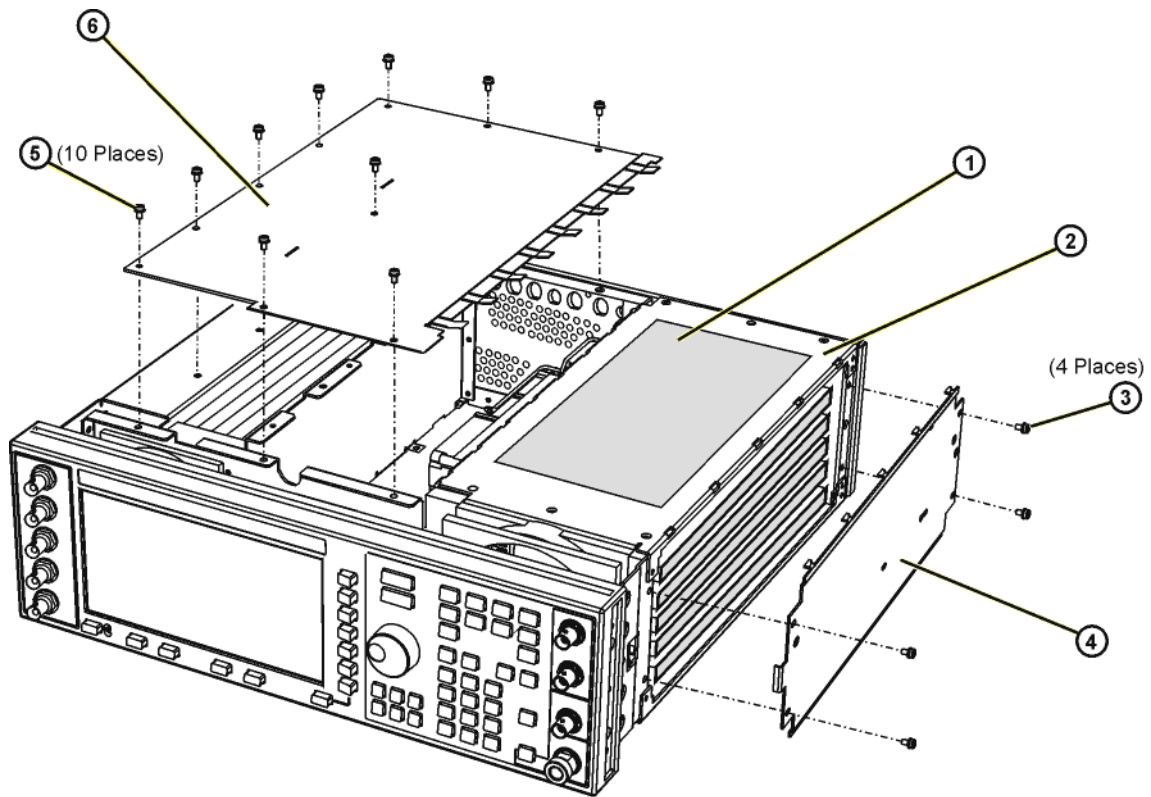

sk752c

Miscellaneous

This section lists part numbers for miscellaneous items that can be used with your signal generator.

Accessories

Table 2-34 **Accessories**

Description	Part Number
ESD Connector End Cap Front-Panel RF Output	1401-0247
ESD Connector End Cap-GPIB	1401-5007
ESD Connector End Cap Coherent Carrier Out	1252-4696
Transit Case	9211-1296
Retainer Cable	E4400-40002
Retainer REX	0510-1643

Documentation

Table 2-35 **Documentation**

Description	Part Number
CD-ROM Documentation	E4400-90501
Installation Guide	E4400-90502
User's Guide	E4400-90503
Key Reference - Volume 1 of 2	E4400-90504
Key Reference - Volume 2 of 2	E4400-90515
Programming Guide	E4400-90505
SCPI Command Reference - Volume 1 of 3	E4400-90506
SCPI Command Reference - Volume 2 of 3	E4400-90535
SCPI Command Reference - Volume 3 of 3	E4400-90594
Programming Compatibility	E4400-90543
Service Guide	E4400-90511
Specifications/Data Sheet (E4438C)	5988-4039EN
Specifications/Data Sheet (E4428C)	5989-1992EN

Abbreviations Used in Part Descriptions

This section defines the reference designators, abbreviations, and option numbers used in the part descriptions in this chapter.

Reference Designator	Definition
A	assembly
AT	attenuator
B	fan
DS	lamp
J	electrical connector; jack
W	cable; transmission path; wire

Abbreviation	Definition
BN	buttonhead (screws)
CPU	central processing unit
CW	conical washer (screws)
EXT	external
FL	flathead (screws)
Ft	feet
Hex	hexagonal
GPIB	general purpose interface bus
HX	hexagonal recess (screws)
I	in-phase
LF	low frequency
M	meters or metric hardware
PC	patch lock (screws) or printed circuit
PN	panhead (screws)
Q	quadrature
Qty	quantity
RF	radio frequency
RPP	reverse power protection
SMA	subminiature type-A
TX	TORX recess (screws)

3 Assembly Replacement

Before You Replace an Assembly

CAUTION Many of the assemblies in this instrument are very susceptible to damage from electrostatic discharge (ESD). Perform service procedures only at a static-safe workstation and wear a grounding strap.

Be sure to review the warning and caution statements described in [Chapter 5, “Safety and Regulatory,” on page 5-1](#) prior to replacing an assembly in your signal generator.

After Replacing or Repairing an Assembly

After you have replaced or repaired an assembly, certain performance tests and adjustments may have to be performed. Please refer to [Chapter 4, “Post-Repair Procedures,” on page 4-1](#), for the list of performance tests and adjustments required for each assembly.

Assemblies That You Can Replace

- “Outer and Inner Instrument Covers” on page 3-4
- “Front Panel” on page 3-6
- “A1 Keyboard” on page 3-8
- “A2 Display” on page 3-11
- “A2DS1 Display Backlight” on page 3-14
- “A3 Front Panel Auxiliary Board” on page 3-17
- “A4 Inverter” on page 3-19
- “A5 Hard Drive (E4438C Only)” on page 3-21
- “A6 Power Supply” on page 3-24
- “A7 Baseband Generator (E4438C Only)” on page 3-26
- “A9 Digital Demodulator (E4438C Only)” on page 3-28
- “A10 I/Q Multiplexer (E4438C Only)” on page 3-30
- “A11 Internal Bit Error Rate Analyzer (E4438C Only)” on page 3-32
- “A12 CPU” on page 3-34
- “A13 Output” on page 3-36
- “A14 Extended Frequency Output” on page 3-38
- “A15 Sampler” on page 3-40
- “A16 Frac-N” on page 3-42
- “A17 Synthesizer” on page 3-44
- “A18 Reference” on page 3-46
- “A19 Daughterboard” on page 3-48
- “A19 Daughterboard Cable Removal” on page 3-50
- “A20 Downconverter (E4438C Only)” on page 3-52
- “A21 YTO Driver and A22 Coupler” on page 3-54
- “A23 Motherboard” on page 3-56
- “A23BT1 Battery” on page 3-59
- “A24 Line Module” on page 3-60
- “Rear Panel” on page 3-62
- “A25 Rear Panel Board (E4438C Only)” on page 3-64
- “A26 Rear Panel LVDS Board (Option 1EM — E4438C Only) and A27 Rear Panel SMB Board (Option 1EM — E4438C Only)” on page 3-66
- “AT1 High-Power Mechanical Attenuator with A28 Reverse Power Protection” on page 3-68
- “AT1 High-Power Mechanical Attenuator” on page 3-70
- “AT1 Electronic Attenuator” on page 3-72
- “A29 DC Blocking Capacitor” on page 3-74
- “B1 Power Supply Fan” on page 3-76
- “B2 Small Fan” on page 3-78
- “B3 Daughterboard/Card Cage Fan” on page 3-80
- “RF Output Connector” on page 3-82

Outer and Inner Instrument Covers

Tools Required

- T-10 driver
- T-15 driver
- T-20 driver

Removal Procedures

Removing the Outer Cover

Refer to [Figure 3-1](#) for this procedure.

1. Disconnect the power cord.
2. Using a T-20 driver, remove the two strap handles (1) by loosening the screws.
3. Using a T-15 driver, remove the center screws (3) on the four rear-panel feet (2).
4. Remove the four bottom feet (5) and (6) from the cover by pushing and pulling the tab.
5. Slide the outer cover (4) off the frame.

Removing the Inner Covers

Refer to [Figure 3-1](#) for this procedure.

1. Using a T-10 driver, remove the ten screws (10) from the inner-top cover (7).
2. Remove the inner-top cover.
3. Using a T-10 driver, remove the four screws (8) from the inner-side cover (9).
4. Slide the inner side cover forward to unlock the sheet metal from the chassis.
5. Remove the inner-side cover.

Replacement Procedure

1. Reverse the order of the removal procedures.
2. Torque all T-10 screws to 9 in-lbs.
3. Torque all T-15 screws to 21 in-lbs.
4. Torque all T-20 screws to 21 in-lbs.

Figure 3-1 Outer and Inner Instrument Cover Removal

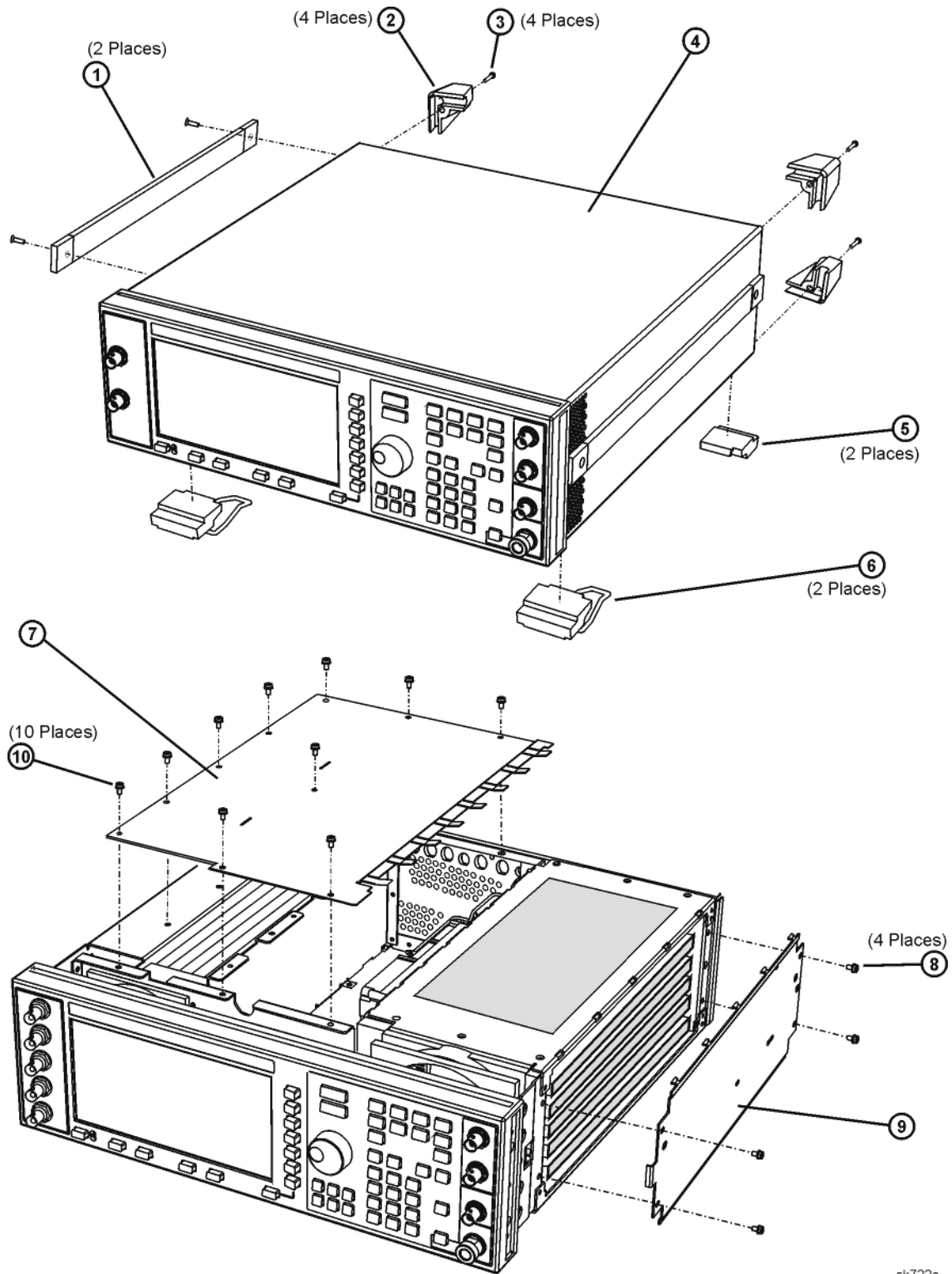

sk722c

Front Panel

Tools Required

- T-15 driver
- long-nose pliers

Removal Procedure

Refer to [Figure 3-2](#) and [Figure 3-3](#) for this procedure.

1. Disconnect the power cord.
2. Remove the covers from the signal generator. Refer to “[Outer and Inner Instrument Covers](#)” on page 3-4.
3. Remove the side trims that cover the four screws (2).
4. Using a T-15 driver, remove the four screws (1) from the sides of the frame.

CAUTION Before removing the front panel from the signal generator, lift and support the front of the signal generator’s frame.

5. Slide the front panel over the RF output connector.
6. If you have an A5 Hard Drive (Option 005), disconnect W26 from the A12 CPU.
7. Disconnect the W35 A3 Front Panel Auxiliary Board cable from J30 of the A23 Motherboard.
8. Disconnect the W36 A1 Keyboard cable from J32 of the A23 Motherboard.
9. Using needle-nose pliers, disconnect the following cables:
 - W1 (I INPUT) from J7 of the A10 I/Q Multiplexer (E4438C only)
 - W2 (Q INPUT) from J8 of the A10 I/Q Multiplexer (E4438C only)
 - W3 (DATA INPUT) from J24 of the A23 Motherboard (E4438C only)
 - W4 (DATA CLOCK) from J21 of the A23 Motherboard (E4438C only)
 - W5 (SYMBOL SYNC) from J23 of the A23 Motherboard (E4438C only)
 - W6 (EXT 1 INPUT) from the A19 Daughterboard (refer to the connector diagram located on the A19 Daughterboard cover)
 - W7 (EXT 2 INPUT) from the A19 Daughterboard (refer to the connector diagram located on the A19 Daughterboard cover)
 - W8 (LF OUTPUT) from the A19 Daughterboard (refer to the connector diagram located on the A19 Daughterboard cover)
10. Remove the front panel.

Replacement Procedure

1. Reverse the order of the removal procedure.
2. Perform the post-repair adjustments and performance tests that pertain to this removal procedure.
3. Torque all T-10 screws to 9 in-lbs.
4. Torque all T-15 screws to 21 in-lbs.
5. Torque all T-20 screws to 21 in-lbs.

Figure 3-2 Front Panel Cover Strips

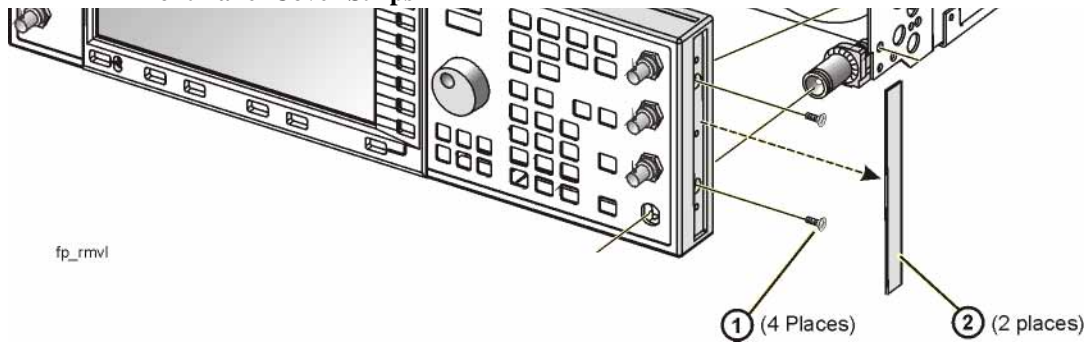
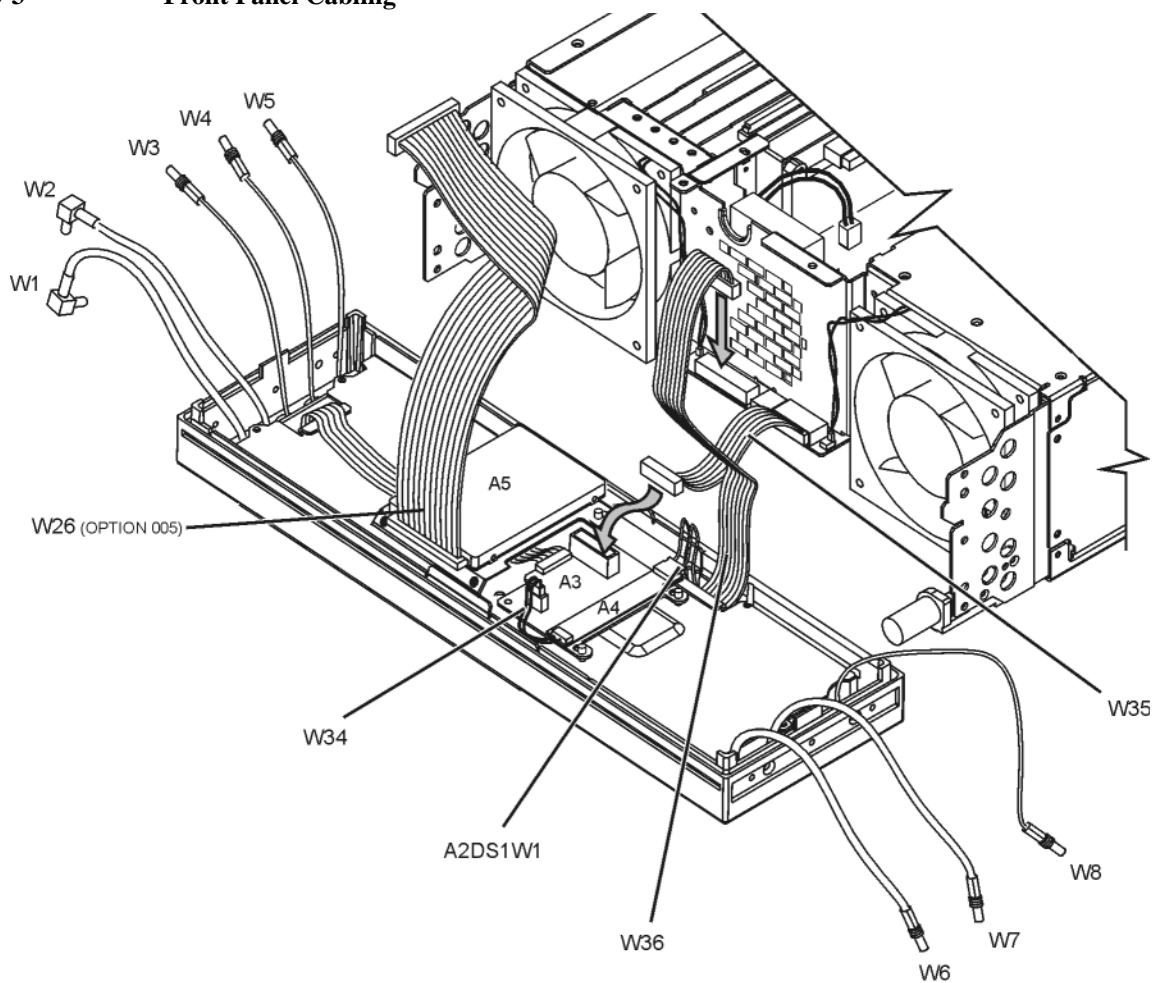

Figure 3-3 Front Panel Cabling



A1 Keyboard

Tools Required

- T-10 driver

Removal Procedure

For instruments with serial prefixes <US4426/MY4426, refer to [Figure 3-4](#) for this procedure.

For instruments with serial prefix ≥US4426/MY4426, refer to [Figure 3-5](#) for this procedure.

1. Disconnect the power cord.
2. Remove the front panel. Refer to [“Front Panel” on page 3-6](#).
3. Disconnect the W1 cable of the A2DS1 Display Backlight cable from the A4 Inverter.
4. If you have an A5 Hard Drive (Option 005), use the T-10 driver to remove the screws (5) and lift the hard drive from the display panel’s sheet metal. For instruments with serial prefixes <US4426/MY4426, there are four screws. For instrument with serial prefix ≥US4426/MY4426, there are two screws.
5. Disconnect the W33 ribbon cable from the A3 Front Panel Auxiliary Board by lifting the white tabs on the connector.
6. Using the T-10 driver, remove the seven screws (1) that secure the RFI shielding (2) to the front panel.
7. Remove the metal shielding.
8. Using the T-10 driver, remove the four screws (3) that secure the A2 Display to the front panel.
9. Remove the A2 Display.
10. Remove the RPG-knob by pulling it away from the front panel.
11. Using the T-10 driver, remove the nine screws (4) that secure the A1 Keyboard to the front panel.
12. Remove the A1 Keyboard.

Replacement Procedure

1. Reverse the order of the removal procedure.
2. Torque all T-10 screws to 9 in-lbs.
3. Perform the post-repair adjustments and performance tests that pertain to this removal procedure.

Figure 3-4 A1 Keyboard, for instruments with serial prefixes <US4426/MY4426

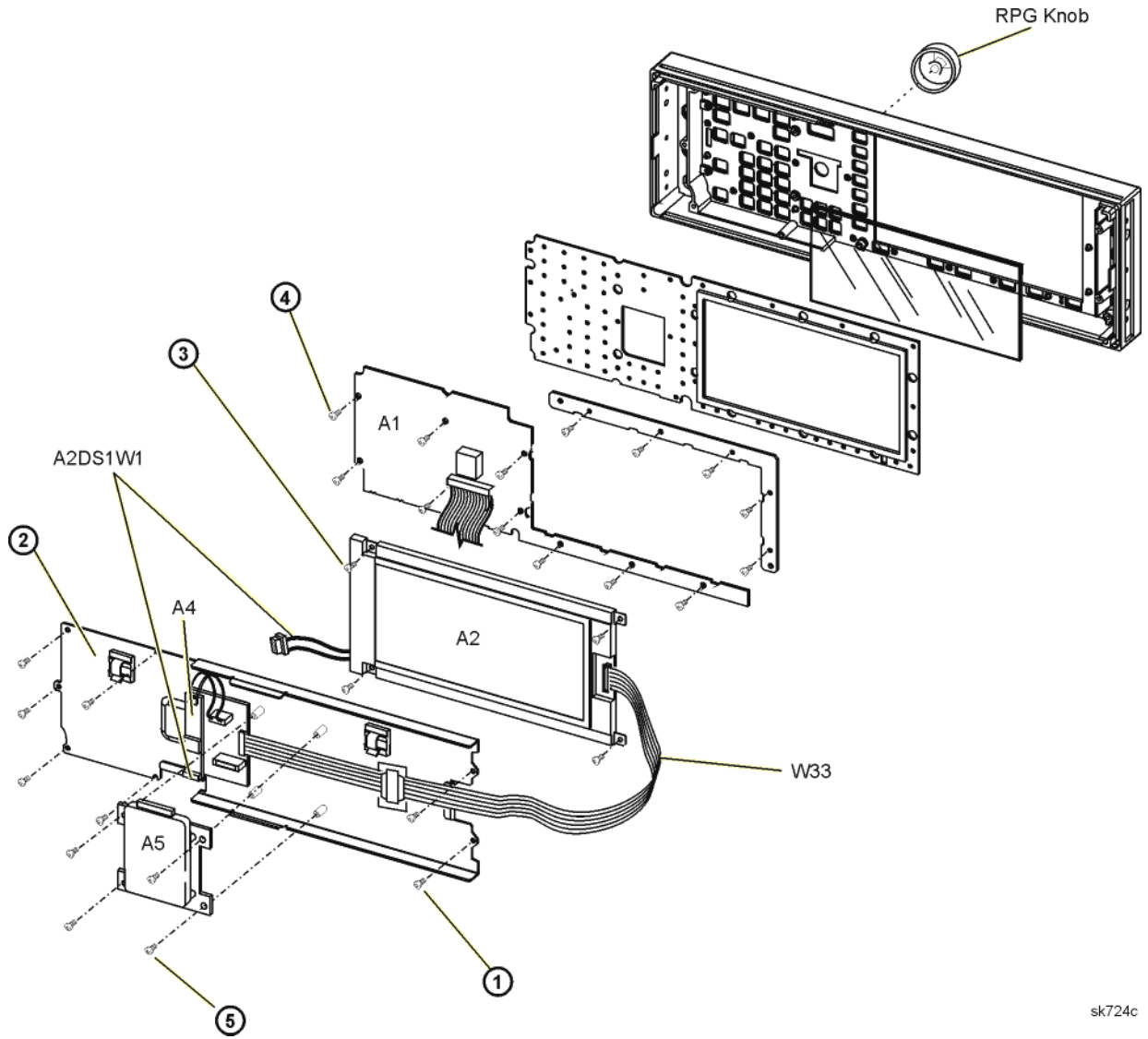

sk724c

Assembly Replacement
A1 Keyboard

Figure 3-5 A1 Keyboard, for instruments with serial prefix \geq US4426/MY4426

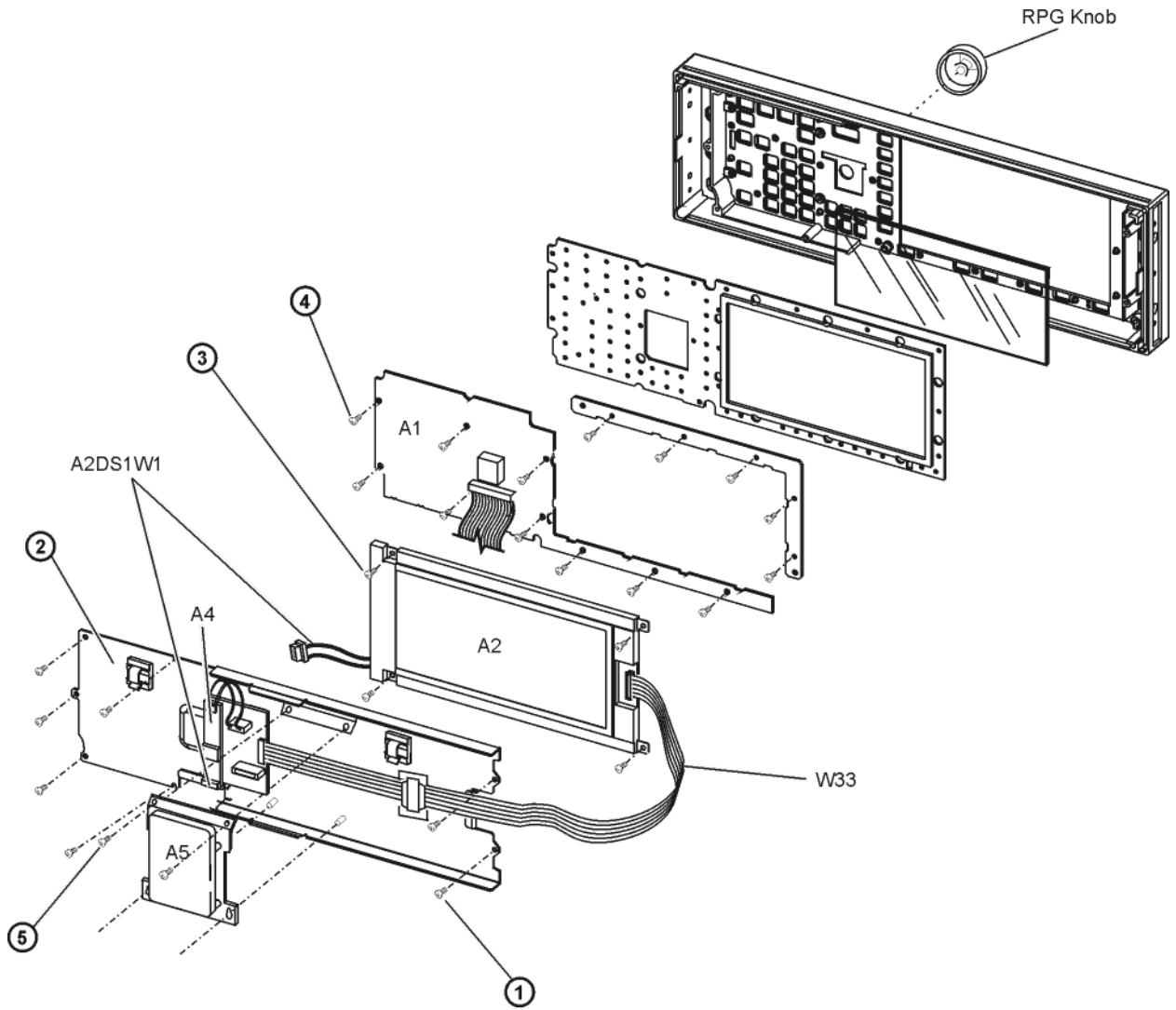

A2 Display

Tools Required

- T-10 driver

Removal Procedure

For instruments with serial prefixes <US4426/MY4426, refer to [Figure 3-6](#) for this procedure.

For instruments with serial prefixes ≥US4426/MY4426, refer to [Figure 3-7](#) for this procedure.

1. Disconnect the power cord.
2. Remove the front panel. Refer to [“Front Panel” on page 3-6](#).
3. Disconnect the W1 cable of the A2DS1 Display Backlight from the A4 Inverter.
4. If you have an A5 Hard Drive (Option 005), use the T-10 driver to remove the screws (4) and lift the hard drive from the display panel's sheet metal. For instruments with serial prefixes <US4426/MY4426, there are four screws. For instrument with serial prefix ≥US4426/MY4426, there are two screws.
5. Disconnect the W33 ribbon cable from the A3 Front Panel Auxiliary Board by lifting the white tabs on the connector.
6. Using the T-10 driver, remove the seven screws (1) that secure the RFI shielding (2) to the front panel.
7. Remove the metal shielding.
8. Using the T-10 driver, remove the four screws (3) that secure the A2 Display to the front panel.
9. Remove the A2 Display.

Replacement Procedure

1. Reverse the order of the removal procedure.
2. Torque all T-10 screws to 9 in-lbs.
3. Perform the post-repair adjustments and performance tests that pertain to this removal procedure.

Figure 3-6 A2 Display, for instruments with serial prefixes <US4426/MY4426

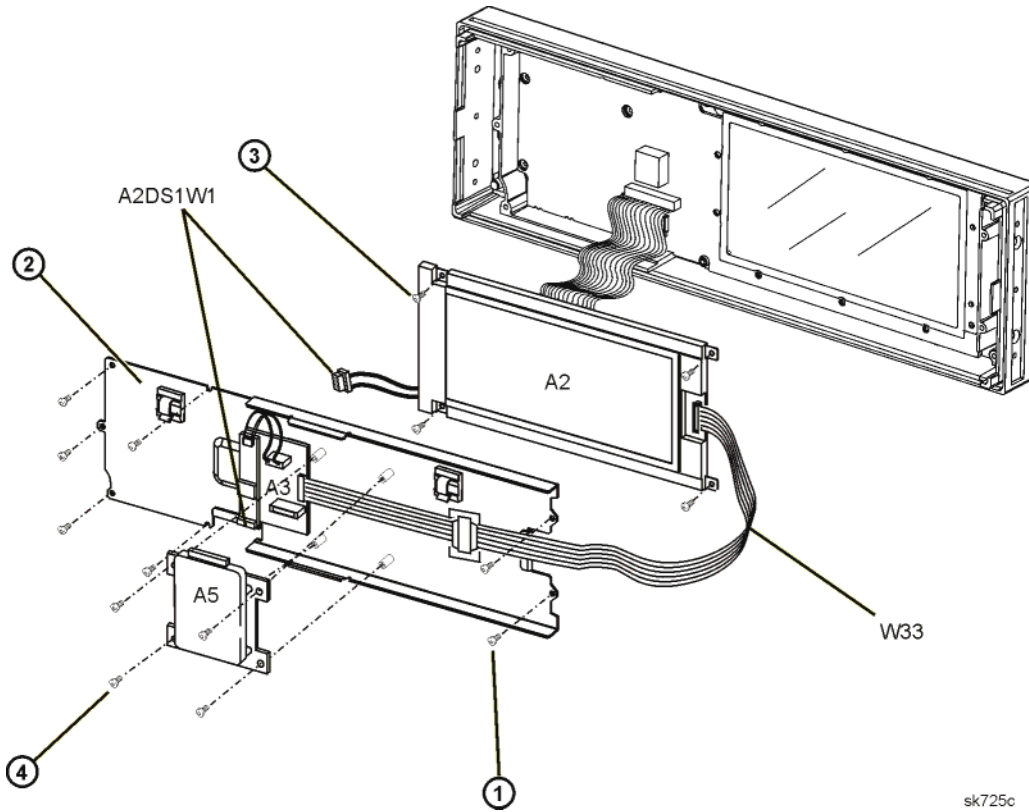

sk725c

Figure 3-7 A2 Display, for instruments with serial prefix \geq US4426/MY4426

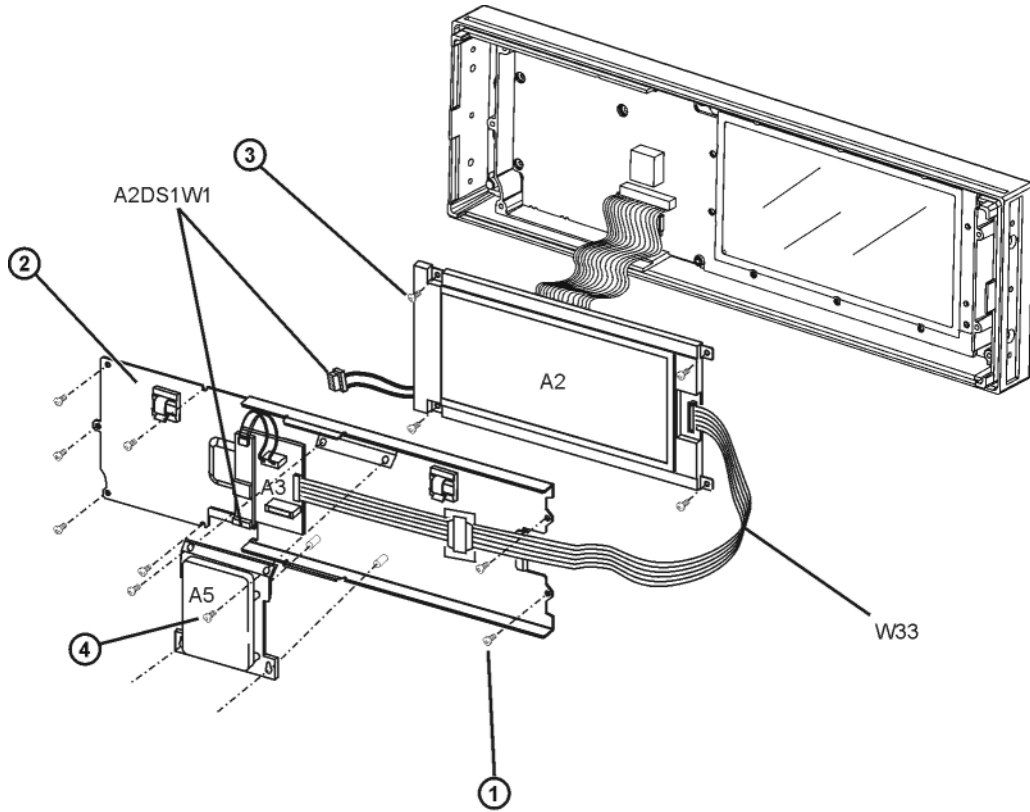

A2DS1 Display Backlight

Tools Required

- T-10 driver
- small phillips screw driver

Removal Procedure

For instruments with serial prefixes <US4426/MY4426, refer to [Figure 3-8](#) for this procedure.

For instruments with serial prefix ≥US4426/MY4426, refer to [Figure 3-9](#) for this procedure.

1. Disconnect the power cord.
2. Remove the front panel. Refer to “[Front Panel](#)” on page 3-6.
3. Disconnect the W1 cable of the A2DS1 Display Backlight from the A4 Inverter.
4. If you have an A5 Hard Drive (Option 005), use the T-10 driver to remove the screws (1) and lift the hard drive from the display panel’s sheet metal. For instruments with serial prefixes <US4426/MY4426, there are four screws. For instrument with serial prefix ≥US4426/MY4426, there are two screws.
5. Disconnect the W33 ribbon cable from the A3 Front Panel Auxiliary Board by lifting the white tabs on the connector.
6. Using the T-10 driver, remove the seven screws (2) that secure the RFI shielding (3) to the front panel.
7. Remove the metal shielding.
8. Using the T-10 driver, remove the four screws (4) that secure the A2 Display to the front panel.
9. Remove the A2 Display.
10. Using a small phillips screw driver, remove the screw (5) that secures the cover (6) over the backlight.
11. Remove the A2DS1 Display Backlight.

Replacement Procedure

NOTE When replacing the A2DS1 Display Backlight, make sure the reflective paper is behind the light.

1. Reverse the order of the removal procedure.
2. Torque all T-10 screws to 9 in-lbs.
3. Perform the post-repair adjustments and performance tests that pertain to this removal procedure.

Figure 3-8 A2DS1 Backlight, for instruments with serial prefixes <US4426/MY4426

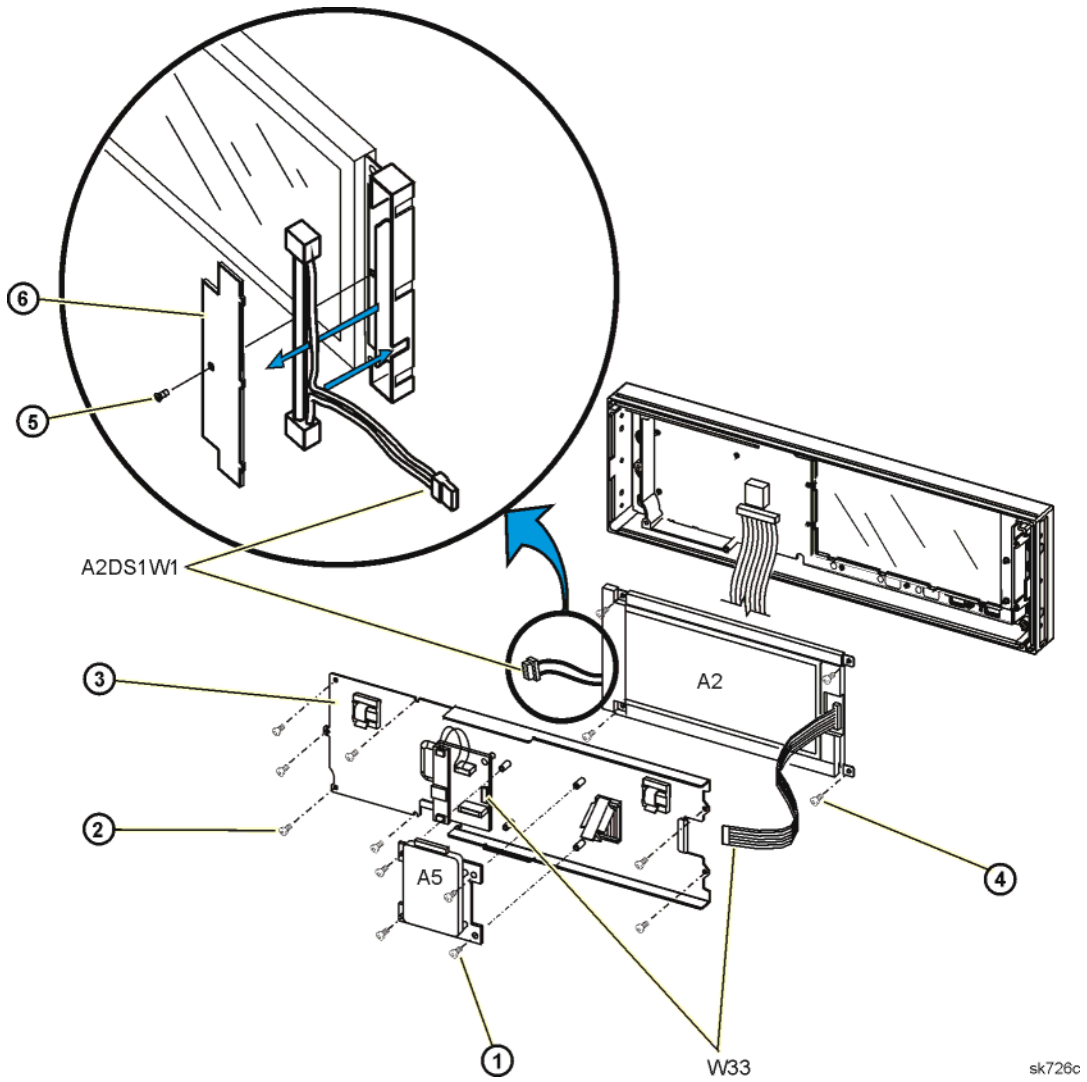
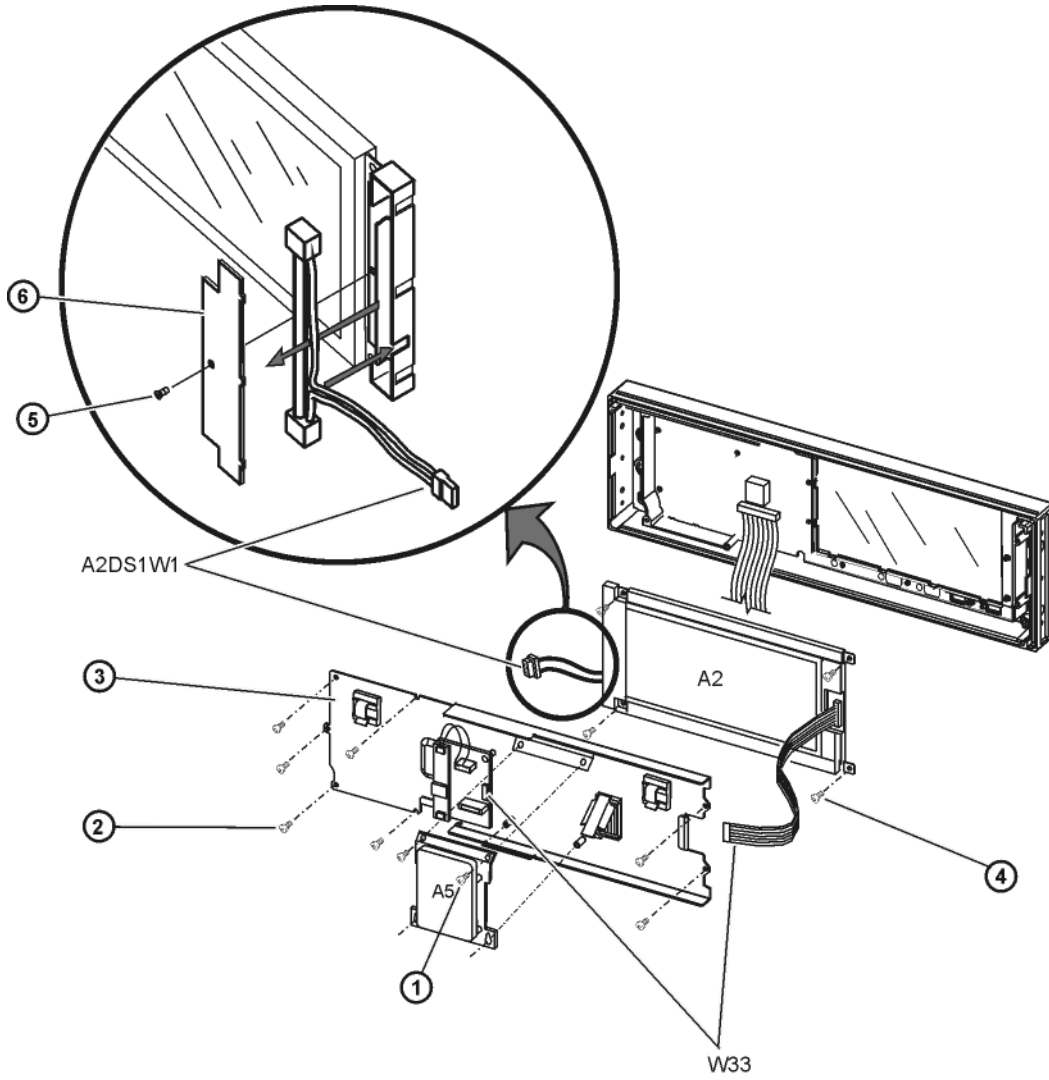

Figure 3-9 A2DS1 Backlight, for instruments with serial prefix \geq US4426/MY4426



A3 Front Panel Auxiliary Board

Tools Required

- T-10 driver

WARNING High voltage is present at the A4 Inverter output (CN2-1). Also, be careful of the fan blades on B1, B2, and B3. Keep hands and fingers away from the fan blades to avoid injury!

Removal Procedure

Refer to [Figure 3-10](#) for this procedure.

1. Disconnect the power cord.
2. Remove the front panel. Refer to [“Front Panel” on page 3-6](#).
3. If you have an A5 Hard Drive, it may be removed to aid the removal and replacement of W33. Refer to [“A5 Hard Drive \(E4438C Only\)” on page 3-21](#).
4. Disconnect the W1 cable of the A2DS1 Display Backlight (1) from the A4 Inverter.
5. Disconnect the W33 ribbon cable (2) from the A3 Front Panel Auxiliary Board by lifting the white tabs on the connector.
6. Using the T-10 driver, remove the two screws (3) from the A3 Front Panel Auxiliary Board (4) and slide the board to remove it from the key slots.
7. Remove the A3 Front Panel Auxiliary Board.

Replacement Procedure

1. Reverse the order of the removal procedure.
2. Torque all T-10 screws to 9 in-lbs.
3. Perform the post-repair adjustments and performance tests that pertain to this removal procedure.

Assembly Replacement
A3 Front Panel Auxiliary Board

Figure 3-10 A3 Front Panel Auxiliary Board

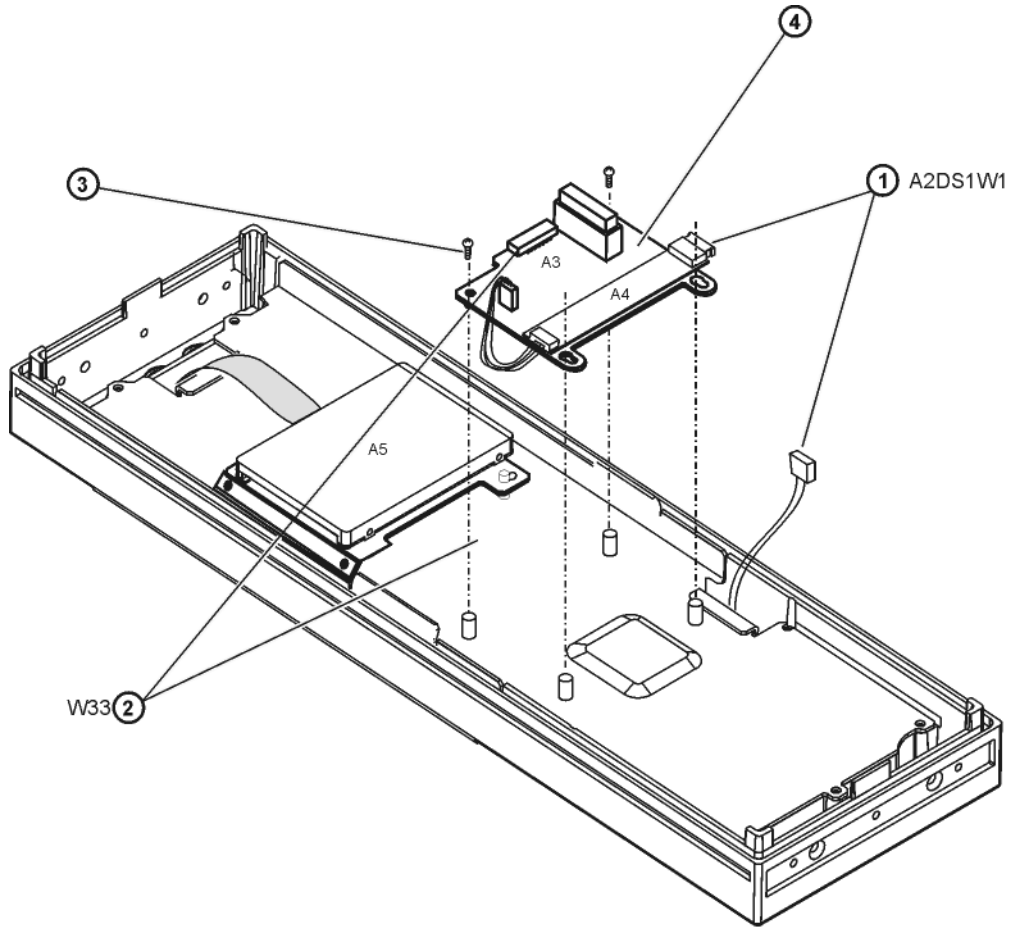

A4 Inverter

Tools Required

- T-10 driver

WARNING High voltage is present at the A4 Inverter output (CN2-1). Also, be careful of the fan blades on B1, B2, and B3. Keep hands and fingers away from the fan blades to avoid injury!

Removal Procedure

Refer to [Figure 3-11](#) for this procedure.

1. Disconnect the power cord.
2. Remove the front panel. Refer to [“Front Panel” on page 3-6](#).
3. Disconnect the W1 cable (2), of the A2DS1 Display Backlight, from the A4 Inverter.
4. Disconnect the W34 cable (1) from the A4 Inverter.

CAUTION The A4 Inverter is fragile and can be damaged when pulled away from the velcro attachment.

5. Remove the A4 Inverter from the A3 Front Panel Auxiliary Board by pulling it away from the printed circuit board. The A4 Inverter is attached with velcro; there are no additional hardware attachments.

Replacement Procedure

1. Reverse the order of the removal procedure.
2. Torque all T-10 screws to 9 in-lbs.
3. Perform the post-repair adjustments and performance tests that pertain to this removal procedure.

Figure 3-11 A4 Inverter

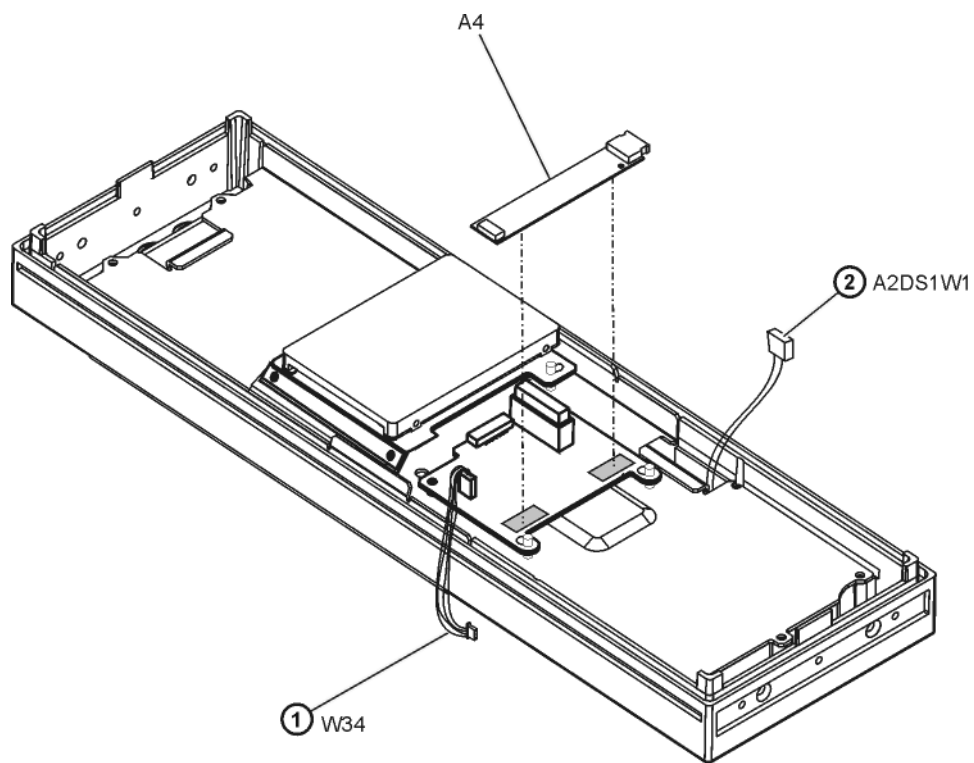

A5 Hard Drive (E4438C Only)

Tools Required

- T-10 driver

Removal Procedure

For instruments with serial prefixes <US4426/MY4426, refer to [Figure 3-12](#) for this procedure.

For instruments with serial prefix ≥US4426/MY4426, refer to [Figure 3-13](#) for this procedure.

1. Disconnect the power cord.
2. Remove the front panels. Refer to [“Front Panel” on page 3-6](#).
3. Using the T-10 driver, remove the screws (1). For instruments with serial prefixes <US4426/MY4426, there are four screws. For instrument with serial prefix ≥US4426/MY4426, there are two screws.
4. Lift and remove the A5 Hard Drive from the display panel’s sheet metal.

Replacement Procedure

1. Reverse the order of the removal procedure.
2. Torque all T-10 screws to 9 in-lbs.
3. Perform the post-repair adjustments and performance tests that pertain to this removal procedure.

Assembly Replacement
A5 Hard Drive (E4438C Only)

Figure 3-12 A5 Hard Drive, for instruments with serial prefixes <US4426/MY4426

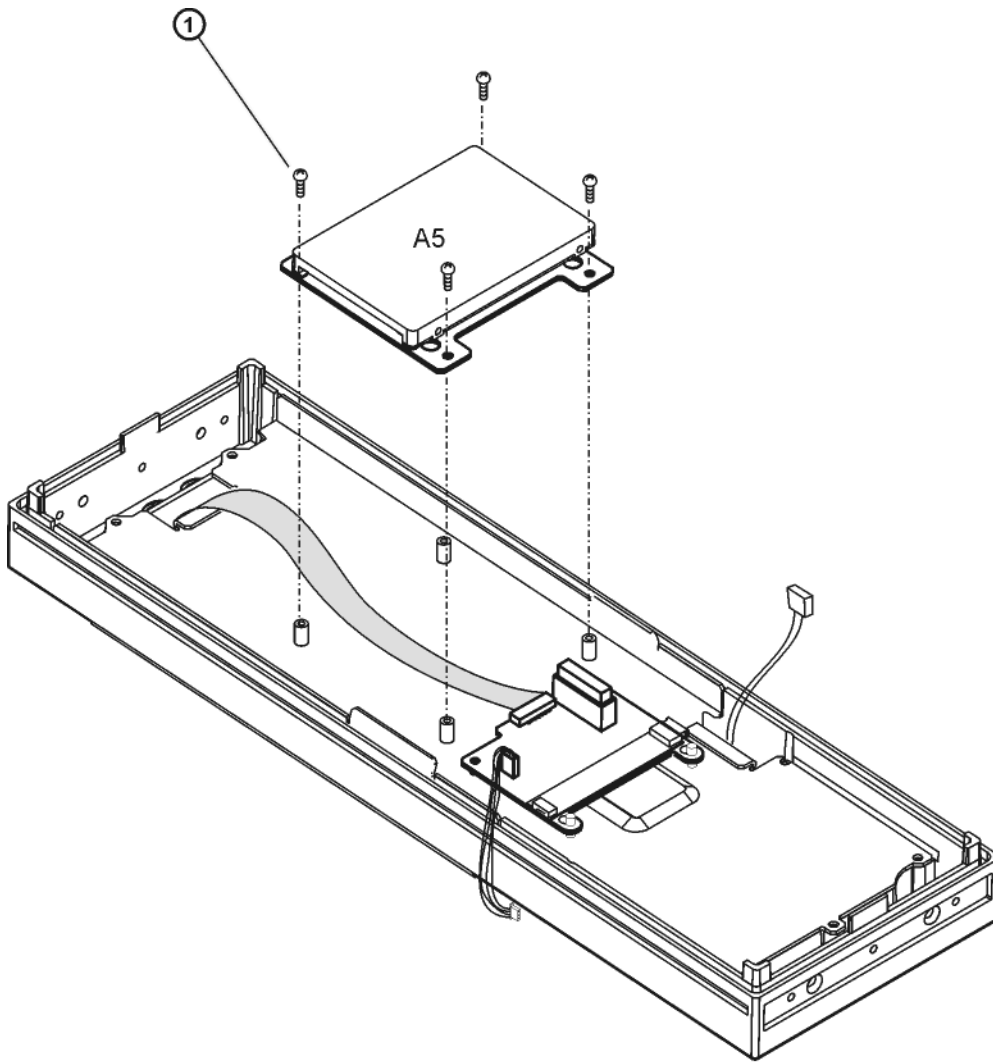
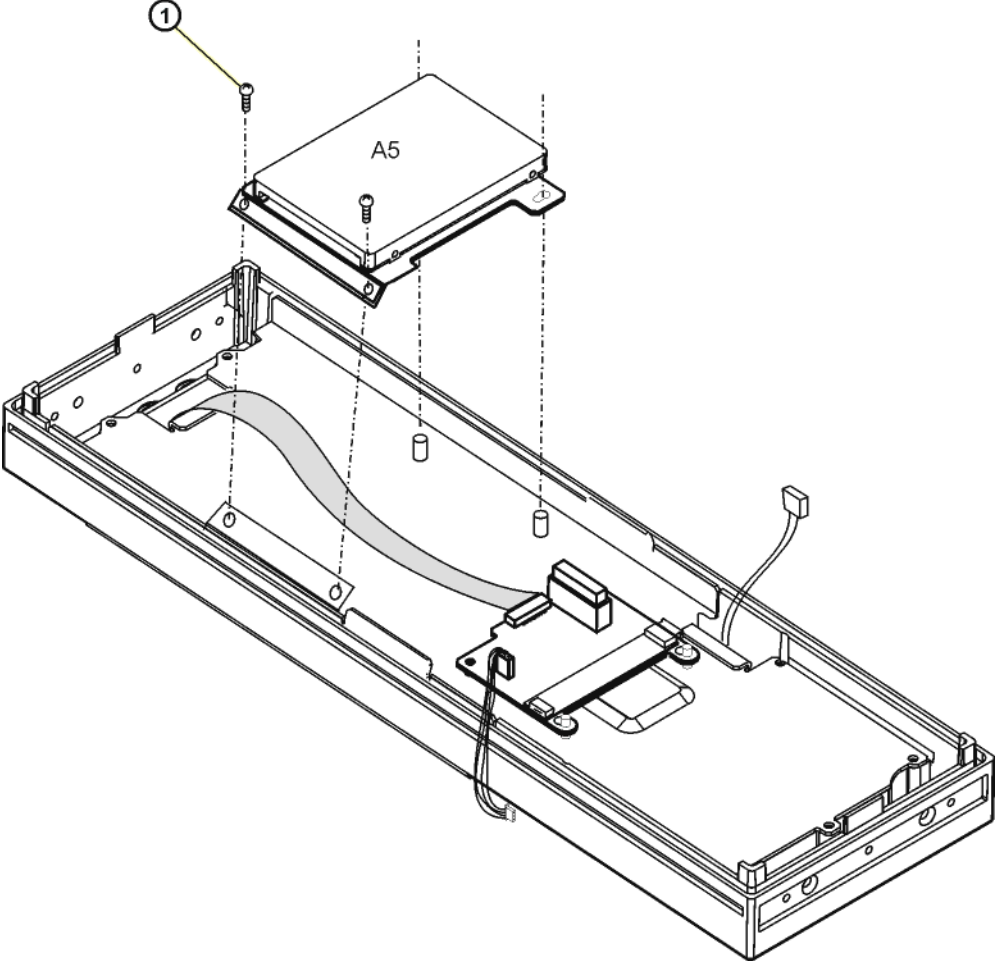

Figure 3-13

A5 Hard Drive, for instruments with serial prefix \geq US4426/MY4426



A6 Power Supply

Tools Required

- T-10 driver

Removal Procedure

Refer to [Figure 3-14](#) for this procedure.

1. Disconnect the power cord.
2. Remove the outer cover. Refer to “[Outer and Inner Instrument Covers](#)” on page 3-4.
3. Using the T-10 driver, remove the three flathead screws (1) and the ten pan-head screws (2) from the A6 Power Supply’s sheet metal cover (3).
4. Disconnect the A24 Line Module cable (A24W1) from the A6 Power Supply (5).
5. Using the T-10 driver, remove the ten screws (4) that hold the A6 Power Supply (5) in place.
6. Remove the A6 Power Supply.

Replacement Procedure

1. Reverse the order of the removal procedure.
2. Torque all T-10 screws to 9 in-lbs.
3. Perform the post-repair adjustments and performance tests that pertain to this removal procedure.

Figure 3-14 A6 Power Supply

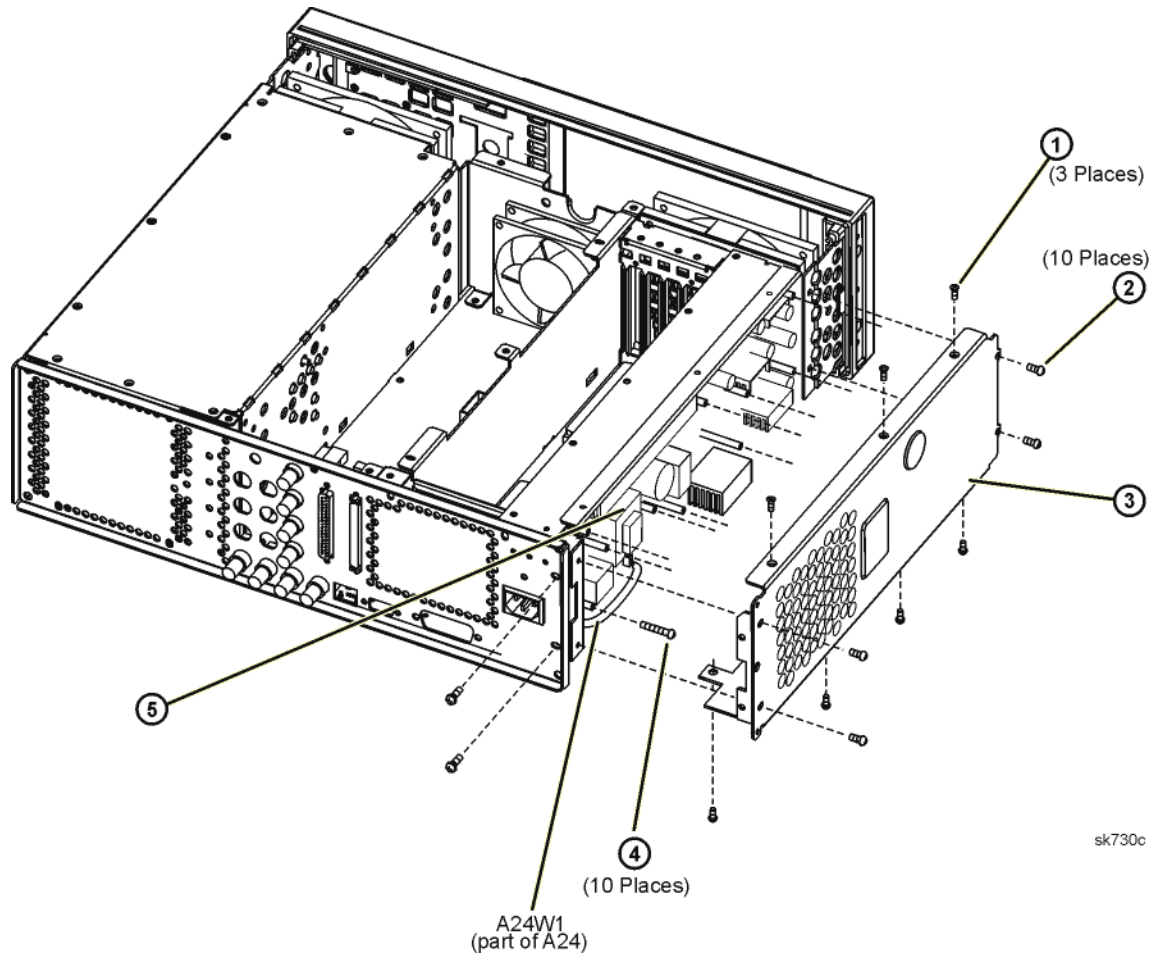

A7 Baseband Generator (E4438C Only)

Tools Required

- Needle-nose pliers

Removal Procedure

Refer to [Figure 3-15](#) for this procedure and to the connector/cable diagram located on the card cage.

1. Disconnect the power cord.
2. Remove the outer cover. Refer to “[Outer and Inner Instrument Covers](#)” on page 3-4.
3. Disconnect the W10 ribbon cable from A7J13.
4. Disconnect the W92 ribbon cable from A7J21 (Option 601/602 only).
5. Using needle-nose pliers, disconnect the W12 cable from A7J800. (This is W78 on an Option 1EM.)
6. Locate Slot 1, lift the retention levers, and disconnect the A7 Baseband Generator from the A23 Motherboard.
7. Lift out the A7 Baseband Generator.

Replacement Procedure

1. Reverse the order of the removal procedure.
2. Perform the post-repair adjustments and performance tests that pertain to this removal procedure.

Figure 3-15 A7 Baseband Generator

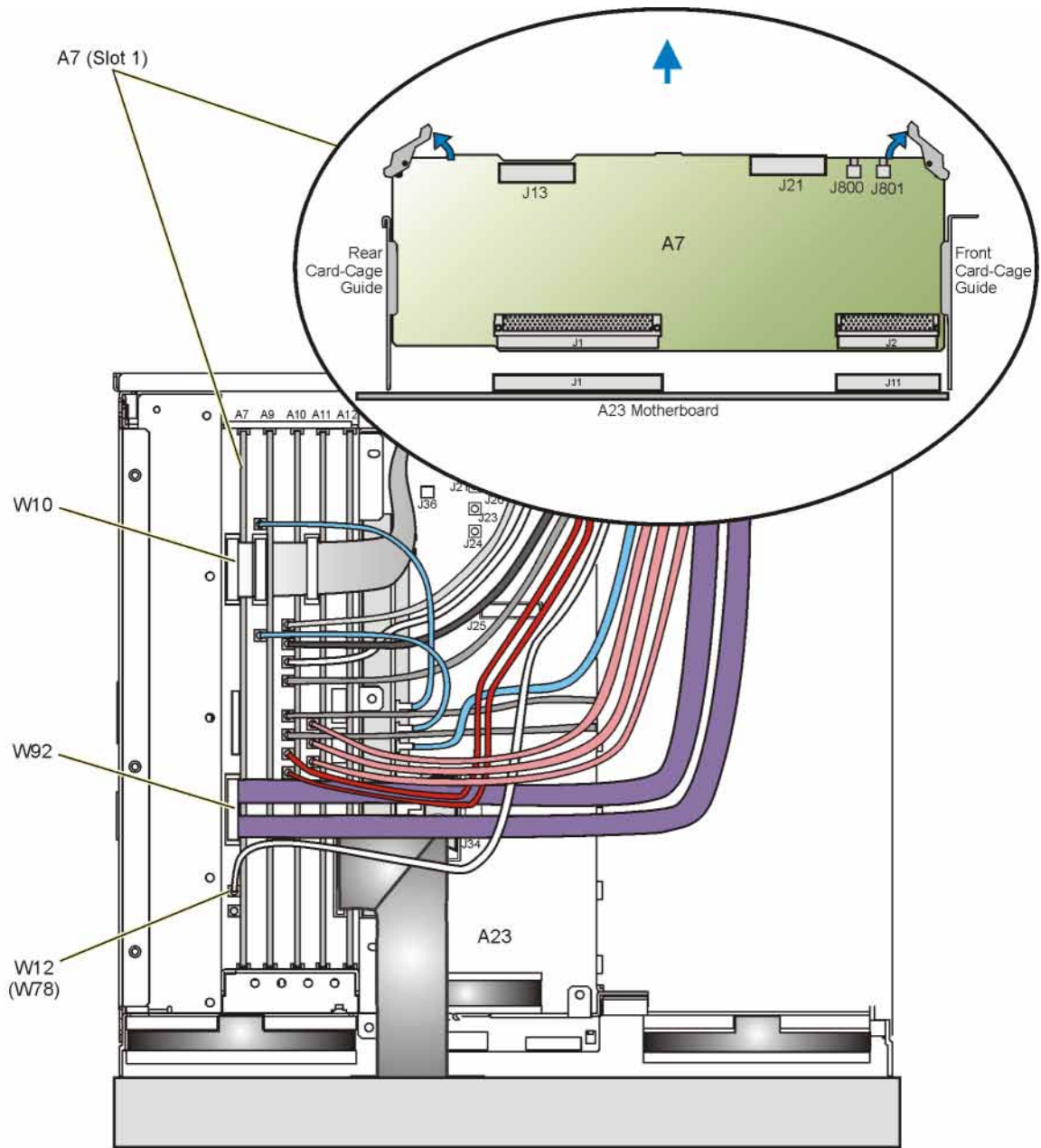

a7_firebld_rmv1

A9 Digital Demodulator (E4438C Only)

Tools Required

- needle-nose pliers

Removal Procedure

Refer to [Figure 3-16](#) for this procedure and to the connector/cable diagram located on the card cage.

1. Disconnect the power cord.
2. Remove the outer cover. Refer to “[Outer and Inner Instrument Covers](#)” on page 3-4.
3. Using needle-nose pliers, disconnect the following cables:
 - W13 cable from A9J4
 - W14 cable from A9J5
 - W12 cable from A7J800. (This is W78 on an Option 1EM.)
4. Disconnect W10 from A7J13 and A9J3.
5. Disconnect W92 from A7J21.
6. Locate Slot 2, lift the retention levers, and disconnect the A9 Digital Demodulator from the A23 Motherboard.
7. Lift out the A9 Digital Demodulator.

Replacement Procedure

1. Reverse the order of the removal procedure.
2. Perform the post-repair adjustments and performance tests that pertain to this removal procedure.

Figure 3-16 A9 Digital Demodulator

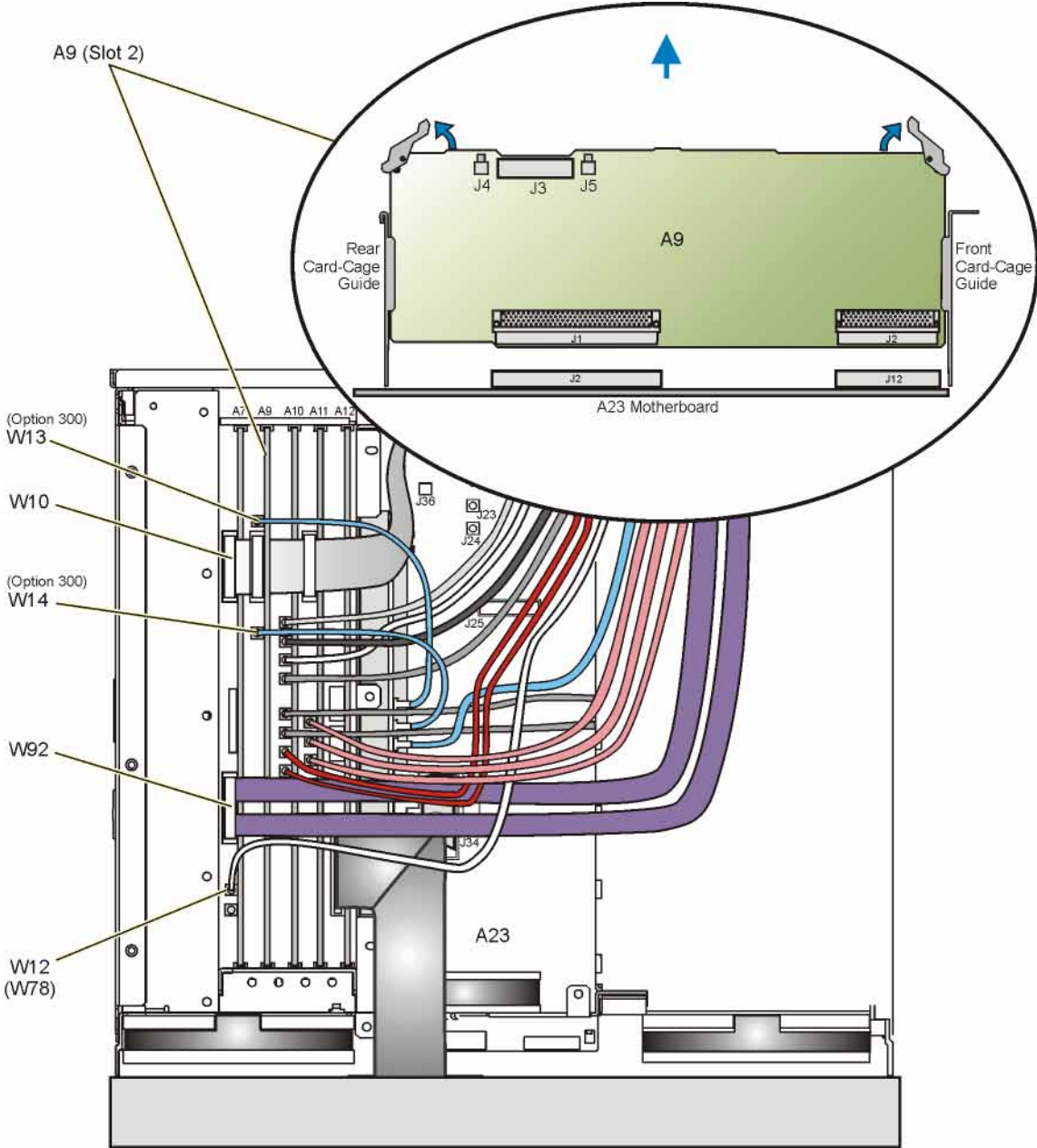

a9-demod_rmv1

A10 I/Q Multiplexer (E4438C Only)

NOTE This procedure applies to the A10 I/Q Multiplexer (Option 501, 502, 503, 504 or Option UNJ) and A10 I/Q Multiplexer (Option 506).

Tools Required

- needle-nose pliers

Removal Procedure

Refer to [Figure 3-17](#) for this procedure and to the connector/cable diagram located on the card cage.

1. Disconnect the power cord.
2. Remove the outer cover. Refer to [“Outer and Inner Instrument Covers” on page 3-4](#).
3. Using needle-nose pliers, disconnect the following cables:
 - W15 cable from A10J14 (This is W77 on an Option 1EM.)
 - W16 cable from A10J13 (This is W76 on an Option 1EM.)
 - W17 cable from A10J12 (This is W75 on an Option 1EM.)
 - W18 cable from A10J11 (This is W74 on an Option 1EM.)
 - W19 cable from A10J10
 - W20 cable from A10J9
 - W1 cable from A10J7 (This is W72 on an Option 1EM.)
 - W2 cable from A10J8 (This is W73 on an Option 1EM.)
 - W12 cable from A7J800. (This is W78 on an Option 1EM.)
4. If you have an instrument with Option 506, use needle-nose pliers and disconnect the following cables:
 - W21 cable from A10J6 (not shown)
 - W22 cable from A10J5 (not shown)
5. Disconnect W10 from A7J13 and A9J3.
6. Disconnect W92 from A7J21.
7. Locate Slot 3, lift the retention levers, and disconnect the A10 I/Q Multiplexer from the A23 Motherboard.
8. Lift out the A10 I/Q Multiplexer.

Replacement Procedure

1. Reverse the order of the removal procedure.
2. Perform the post-repair adjustments and performance tests that pertain to this removal procedure.

Figure 3-17 **A10 I/Q Multiplexer**

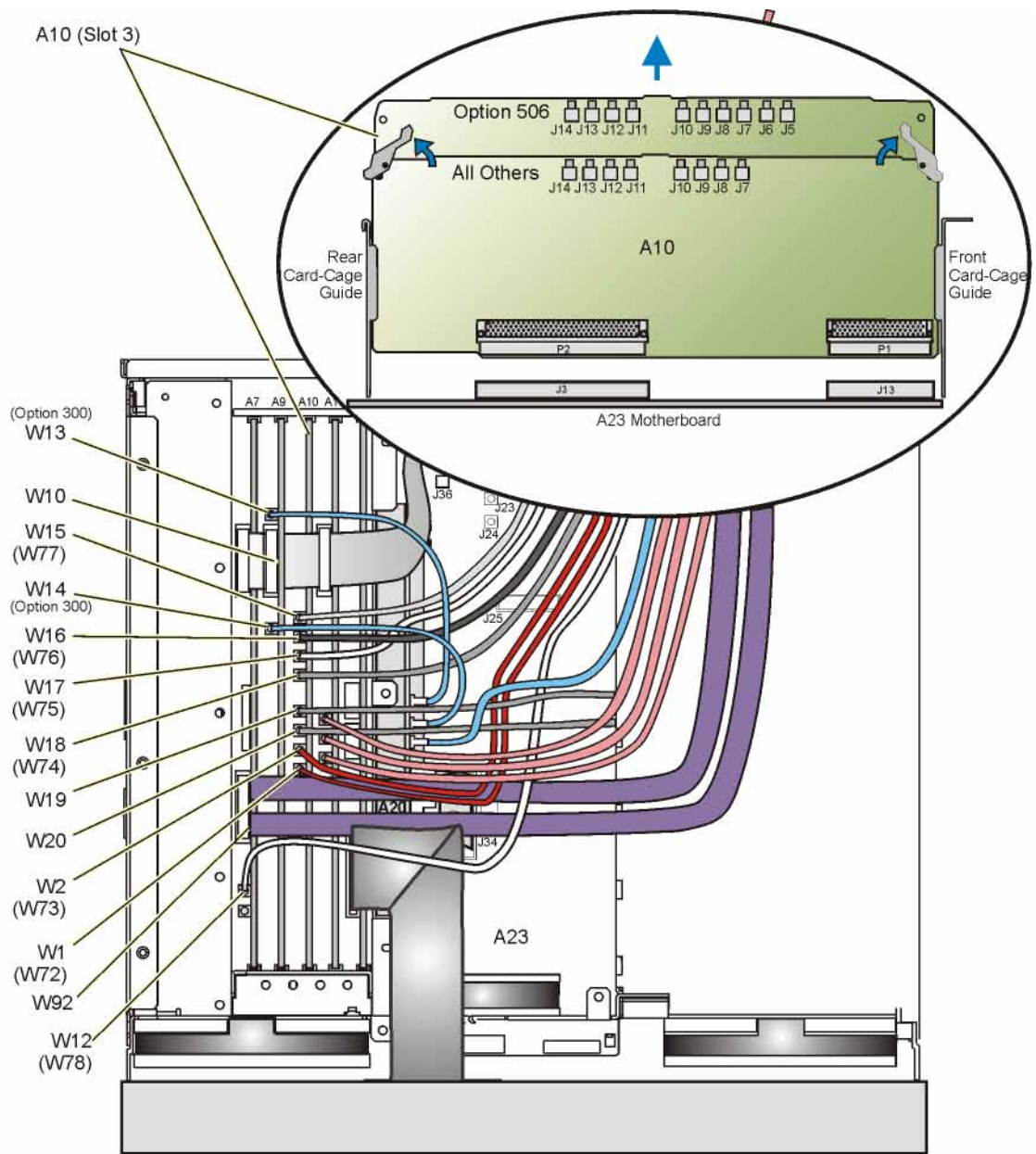

a10-iq-mux_rmv

A11 Internal Bit Error Rate Analyzer (E4438C Only)

Tools Required

- needle-nose pliers

Removal Procedure

Refer to [Figure 3-18](#) for this procedure and to the connector/cable diagram located on the card cage.

1. Disconnect the power cord.
2. Remove the outer cover. Refer to “[Outer and Inner Instrument Covers](#)” on page 3-4.
3. Using needle-nose pliers, disconnect the following cables:
 - W15 cable from A10J14 (This is W77 on an Option 1EM.)
 - W16 cable from A10J13 (This is W76 on an Option 1EM.)
 - W17 cable from A10J12 (This is W75 on an Option 1EM.)
 - W18 cable from A10J11 (This is W74 on an Option 1EM.)
 - W19 cable from A10J10
 - W20 cable from A10J9
 - W1 cable from A10J7 (This is W72 on an Option 1EM.)
 - W2 cable from A10J8 (This is W73 on an Option 1EM.)
 - W12 cable from A7J800 (This is W78 on an Option 1EM.)
4. If you have an instrument with Option 506, use needle-nose pliers and disconnect the following cables:
 - W21 cable from A10J6 (not shown)
 - W22 cable from A10J5 (not shown)
5. Using needle-nose pliers, disconnect the following Option UN7 cables:
 - W23 from A11J4
 - W24 from A11J5
 - W25 from A11J6
6. Disconnect W10 from A7J13, A9J3, and A11J3.
7. Disconnect W92 from A7J21.
8. Locate Slot 4, lift the retention levers, and disconnect the A11 Internal Bit Error Rate Analyzer from the A23 Motherboard.
9. Lift out the A11 Internal Bit Error Rate Analyzer.

Replacement Procedure

1. Reverse the order of the removal procedure.
2. Perform the post-repair adjustments and performance tests that pertain to this removal procedure.

Figure 3-18 A11 Internal Bit Error Rate Analyzer

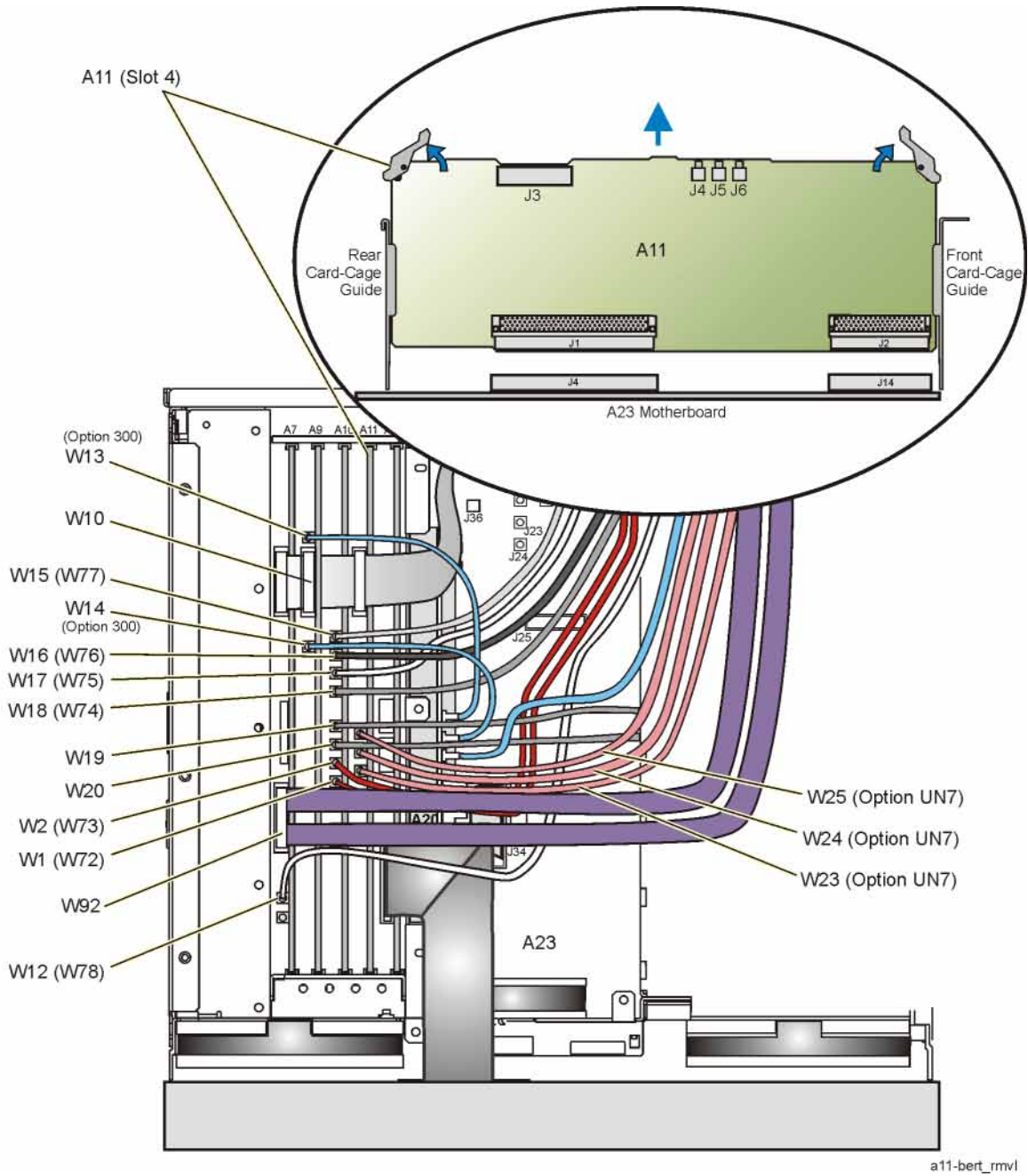

A12 CPU

Tools Required

- needle-nose pliers

Removal Procedure

Refer to [Figure 3-19](#) for this procedure and to the connector/cable diagram located on the card cage.

1. Turn the signal generator on.
2. Use the following SCPI command, “Diag:File:Back”, to backup your CAL data and option information to the MB FLASH.
3. Turn the signal generator off.
4. Disconnect the power cord.
5. Remove the outer cover. Refer to [“Outer and Inner Instrument Covers” on page 3-4](#).
6. If you have an E4438C, using needle-nose pliers, disconnect the following cables. If you have an E4428C, skip to [step 12](#).
 - W15 cable from A10J14 (This is W77 on an Option 1EM.)
 - W16 cable from A10J13 (This is W76 on an Option 1EM.)
 - W17 cable from A10J12 (This is W75 on an Option 1EM.)
 - W18 cable from A10J11 (This is W74 on an Option 1EM.)
 - W19 cable from A10J10
 - W20 cable from A10J9
 - W1 cable from A10J87 (This is W72 on an Option 1EM.)
 - W2 cable from A10J8 (This is W73 on an Option 1EM.)
 - W12 cable from A7J800 (This is W78 on an Option 1EM.)
7. If you have an instrument with Option 506, use needle-nose pliers and disconnect the following cables:
 - W21 cable from A10J6 (not shown)
 - W22 cable from A10J5 (not shown)
8. Using needle-nose pliers, disconnect the following Option UN7 cables:
 - W23 from A11J4
 - W24 from A11J5
 - W25 from A11J6
9. Disconnect W10 from A7J13, A9J3, and A11J3.
10. Disconnect W92 from A7J21.
11. If you have an instrument with Option 005, disconnect W26 cable from the A12P3.
12. Locate Slot 5, lift the retention levers, and disconnect the A12 CPU from the A23 Motherboard.
13. Lift out the A12 CPU.

Replacement Procedure

1. Reverse the order of the removal procedure.
2. Turn the signal generator on.
3. Use the SCPI command “Diag:File:Rest”, to copy the MB FLASH information to the new CPU board.
4. Perform the post-repair adjustments and performance tests that pertain to this removal procedure.

Figure 3-19 A12 CPU

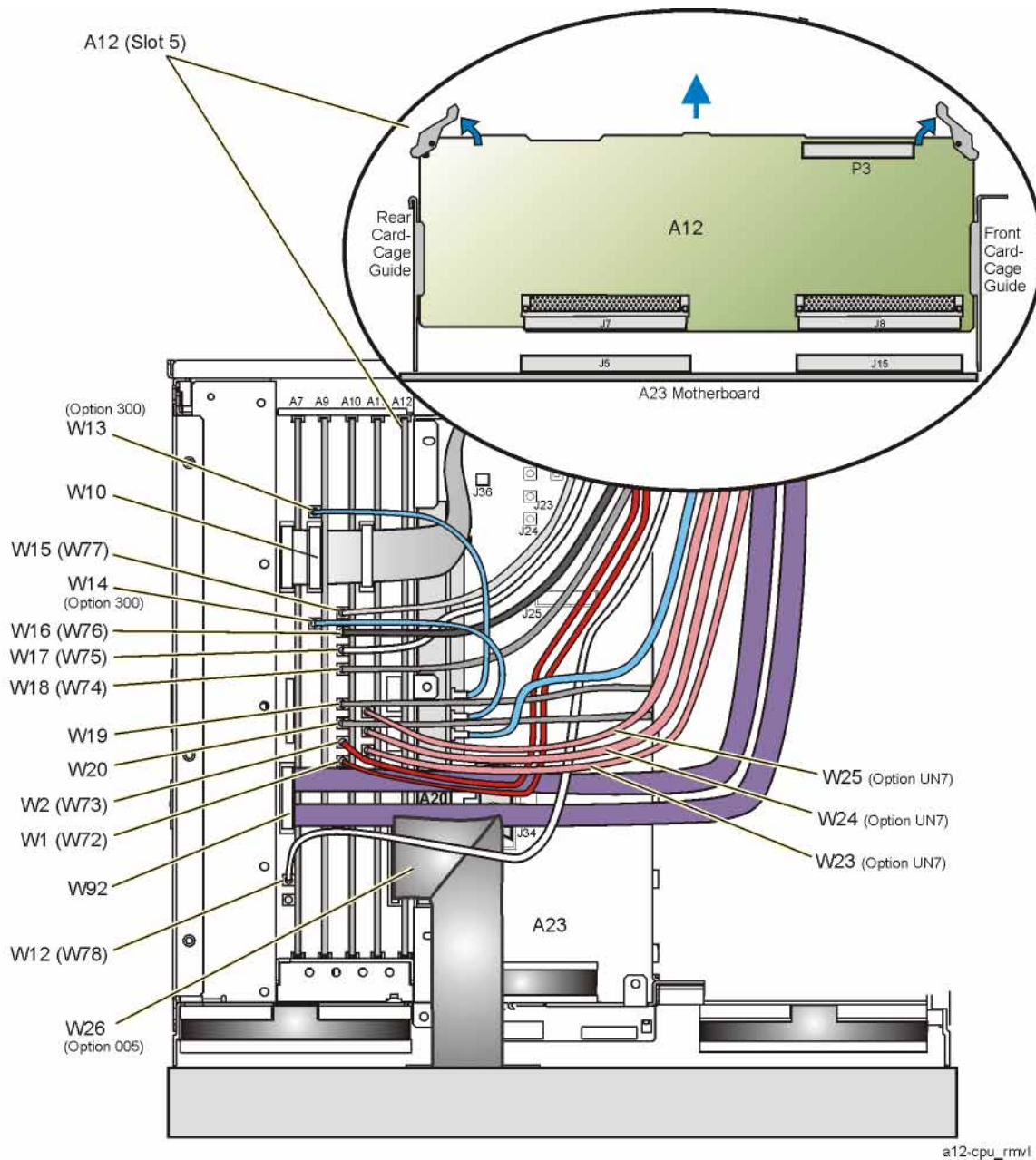

A13 Output

NOTE This procedure applies to both the A13 Output (Option 501, 502, 503, 504 or Option UNJ) and the A13 Output (Option UNB).

Tools Required

- none

Removal Procedure

Refer to [Figure 3-20](#) for this procedure and to the connector/cable diagram located on the card cage.

1. Disconnect the power cord.
2. Remove the outer and inner-side covers. Refer to “[Outer and Inner Instrument Covers](#)” on page 3-4.
3. Locate Side-SLOT 1, lift the retention levers, and disconnect the A13 Output from the A19 Daughterboard.
4. Slide out the A13 Output.

Replacement Procedure

1. Reverse the order of the removal procedure.
2. Perform the post-repair adjustments and performance tests that pertain to this removal procedure.

Figure 3-20 A13 Output

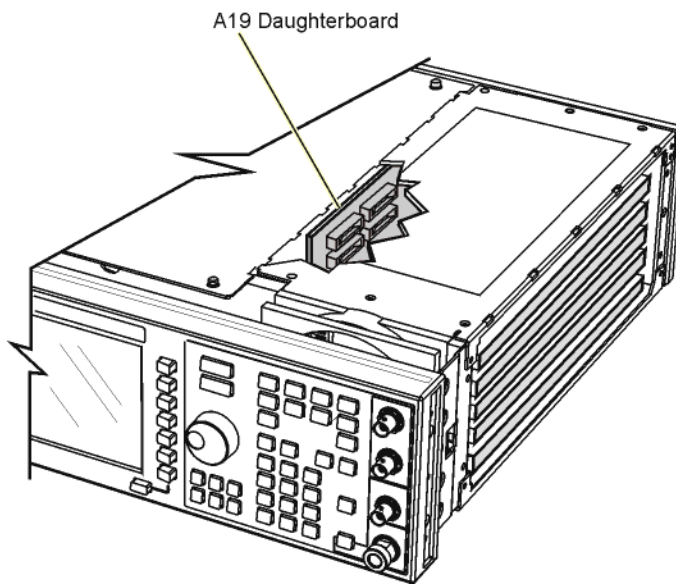
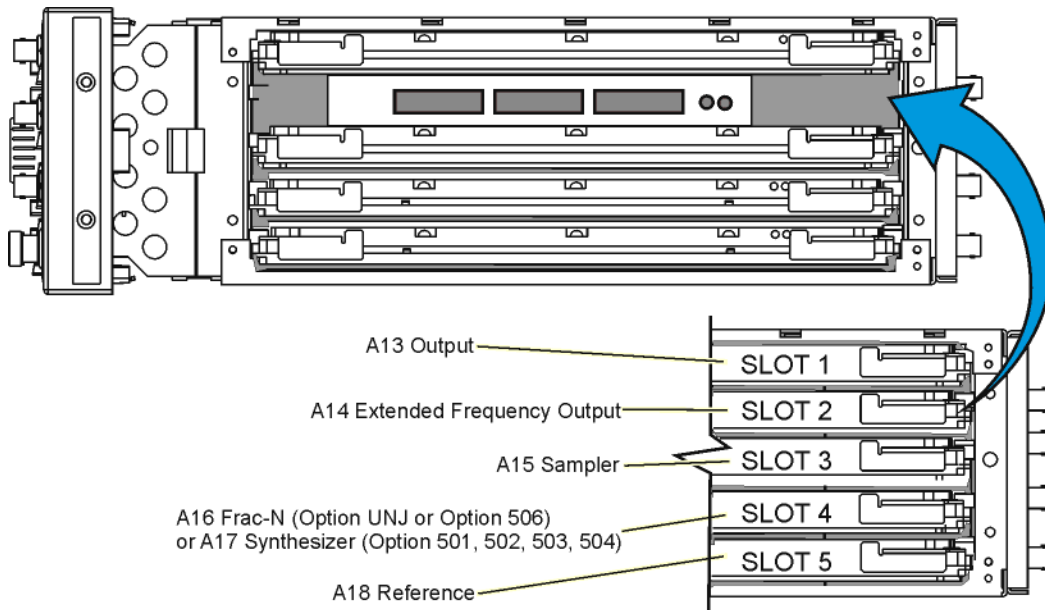

A14 Extended Frequency Output

Tools Required

- none

Removal Procedure

Refer to [Figure 3-21](#) for this procedure and to the connector/cable diagram located on the card cage.

1. Disconnect the power cord.
2. Remove the outer and inner-side covers. Refer to “[Outer and Inner Instrument Covers](#)” on page 3-4.
3. Locate Side-SLOT 2, lift the retention levers, and disconnect the A14 Extended Frequency Output from the A19 Daughterboard.
4. Slide out the A14 Extended Frequency Output.

Replacement Procedure

1. Reverse the order of the removal procedure.
2. Perform the post-repair adjustments and performance tests that pertain to this removal procedure.

Figure 3-21 A14 Extended Frequency Output

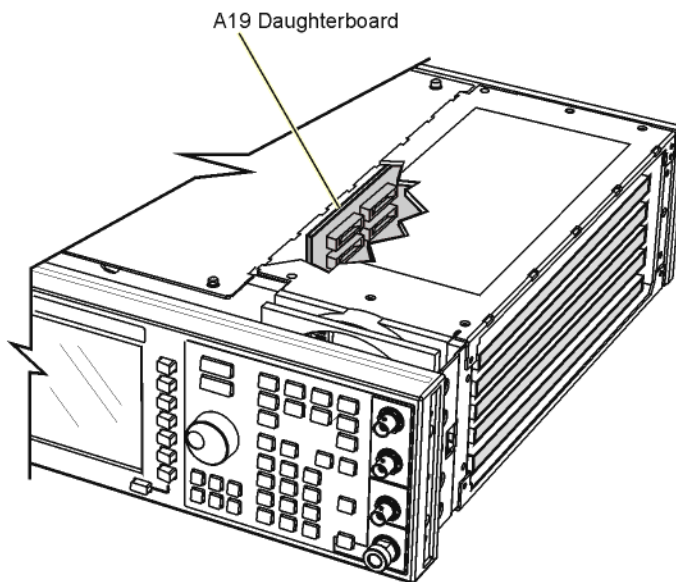
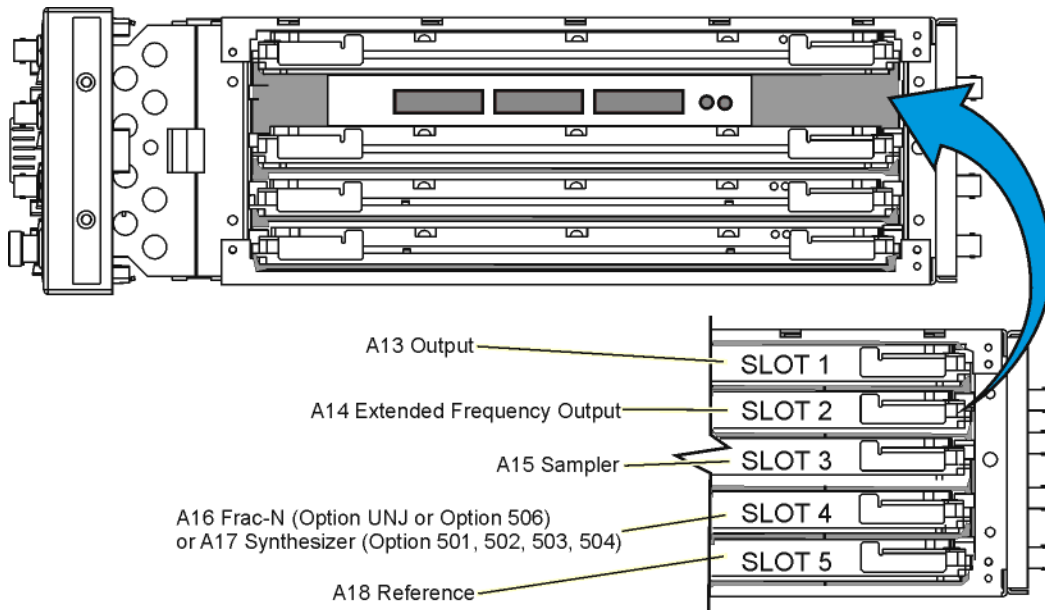

A15 Sampler

Tools Required

- none

Removal Procedure

Refer to [Figure 3-22](#) for this procedure and to the connector/cable diagram located on the card cage.

1. Disconnect the power cord.
2. Remove the outer and inner-side covers. Refer to “[Outer and Inner Instrument Covers](#)” on page 3-4.
3. Locate Side-SLOT 3, lift the retention levers, and disconnect the A15 Sampler from the A19 Daughterboard.
4. Slide out the A15 Sampler.

Replacement Procedure

1. Reverse the order of the removal procedure.
2. Perform the post-repair adjustments and performance tests that pertain to this removal procedure.

Figure 3-22 A15 Sampler

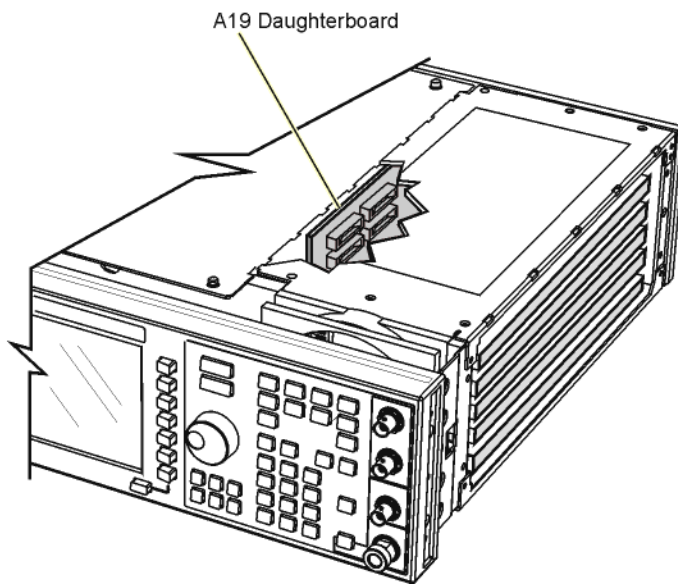
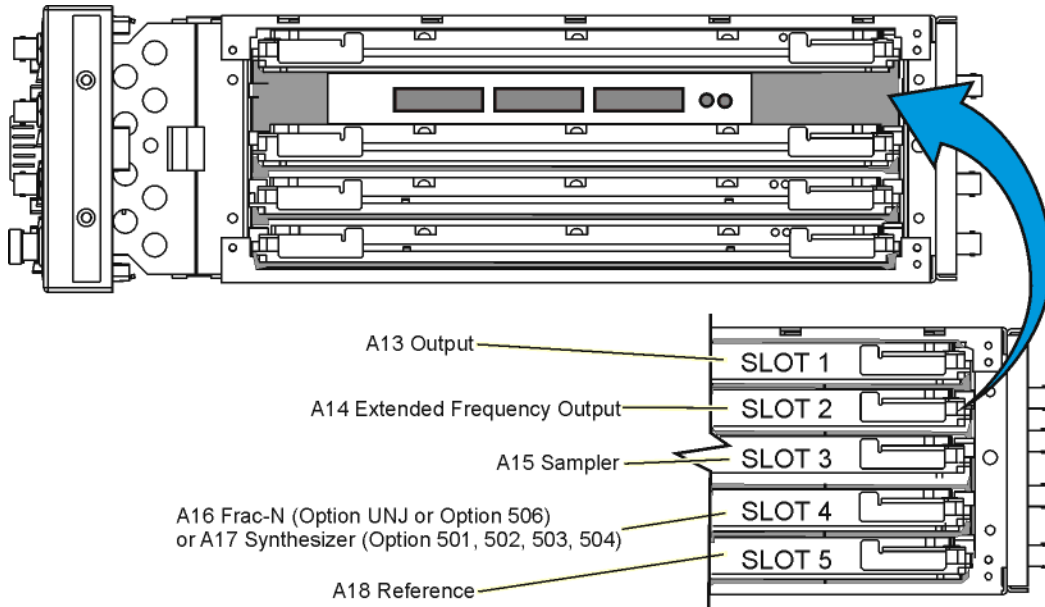

A16 Frac-N

Tools Required

- none

Removal Procedure

Refer to [Figure 3-23](#) for this procedure and to the connector/cable diagram located on the card cage.

1. Disconnect the power cord.
2. Remove the outer and inner-side covers. Refer to “[Outer and Inner Instrument Covers](#)” on page 3-4.
3. Locate Side-SLOT 4, lift the retention levers, and disconnect the A16 Frac-N from the A19 Daughterboard.
4. Slide out the A16 Frac-N.

Replacement Procedure

1. Reverse the order of the removal procedure.
2. Perform the post-repair adjustments and performance tests that pertain to this removal procedure.

Figure 3-23 A16 Frac-N

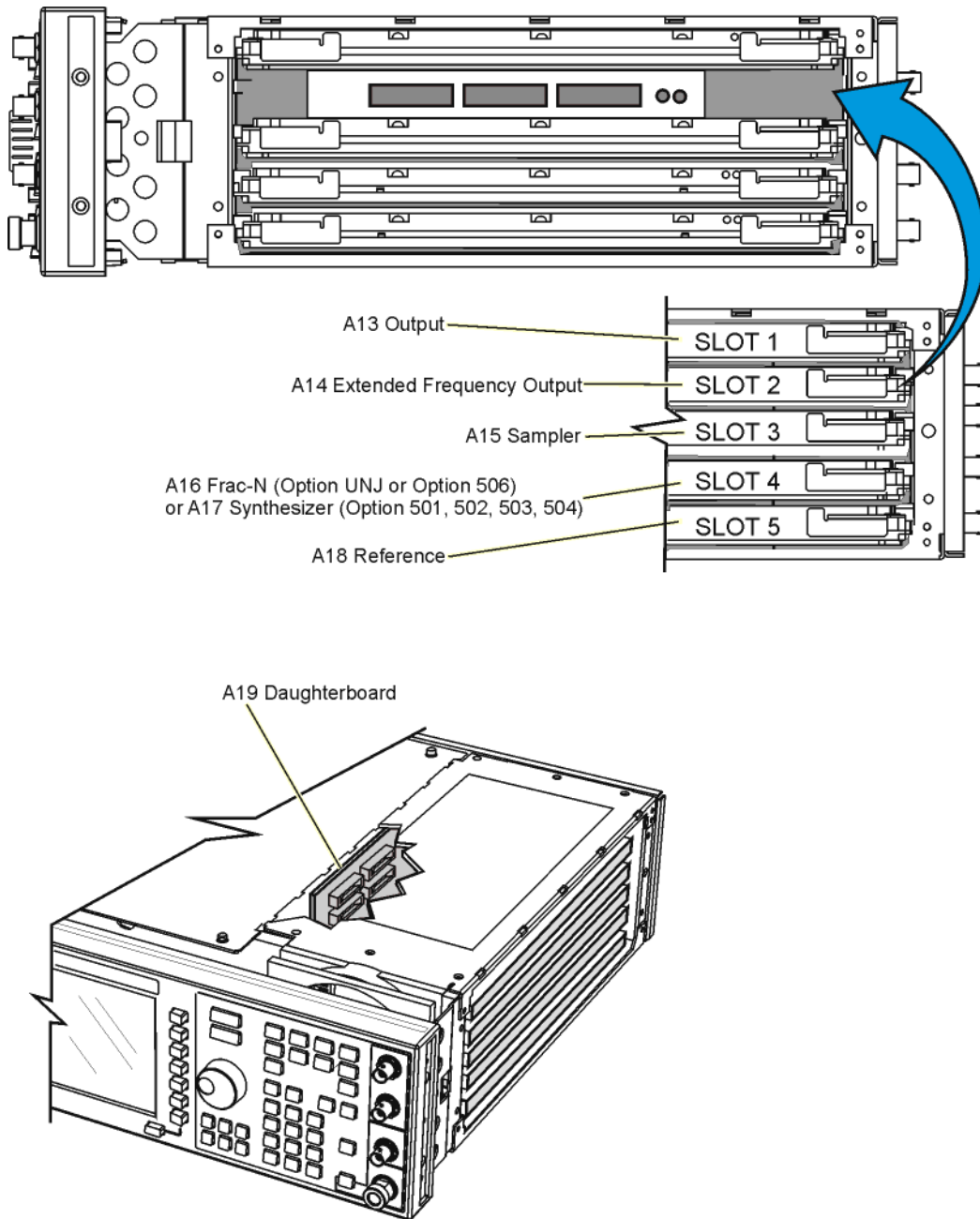

A17 Synthesizer

Tools Required

- none

Removal Procedure

Refer to [Figure 3-24](#) for this procedure and to the connector/cable diagram located on the card cage.

1. Disconnect the power cord.
2. Remove the outer and inner-side covers. Refer to “[Outer and Inner Instrument Covers](#)” on page 3-4.
3. Locate Side-SLOT 4, lift the retention levers, and disconnect the A17 Synthesizer from the A19 Daughterboard.
4. Slide out the A17 Synthesizer.

Replacement Procedure

1. Reverse the order of the removal procedure.
2. Perform the post-repair adjustments and performance tests that pertain to this removal procedure.

Figure 3-24 A17 Synthesizer

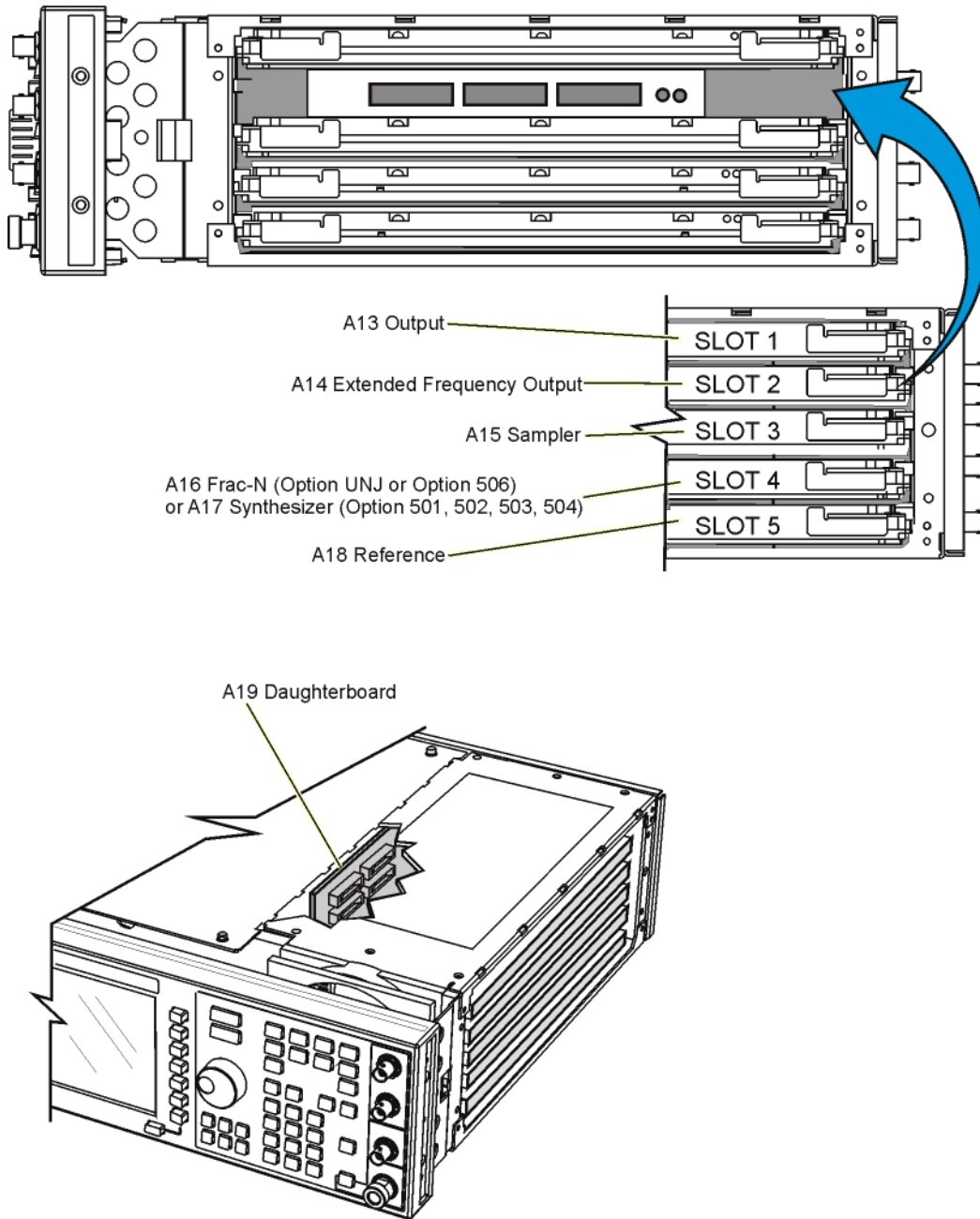

A18 Reference

NOTE This procedure applies to the A18 Reference (Option 501, 502, 503, 504), A18 Reference (Option 501, 502, 503, 504 with Option 1E5), and A18 Reference (Option UNJ or Option 506).

Tools Required

- none

Removal Procedure

Refer to [Figure 3-25](#) for this procedure and to the connector/cable diagram located on the card cage.

1. Disconnect the power cord.
2. Remove the outer and inner-side covers. Refer to [“Outer and Inner Instrument Covers” on page 3-4](#).
3. Locate Side-SLOT 5, lift the retention levers, and disconnect the A18 Reference from the A19 Daughterboard.
4. Slide out the A18 Reference.

Replacement Procedure

1. Reverse the order of the removal procedure.
2. Perform the post-repair adjustments and performance tests that pertain to this removal procedure.

Figure 3-25 A18 Reference

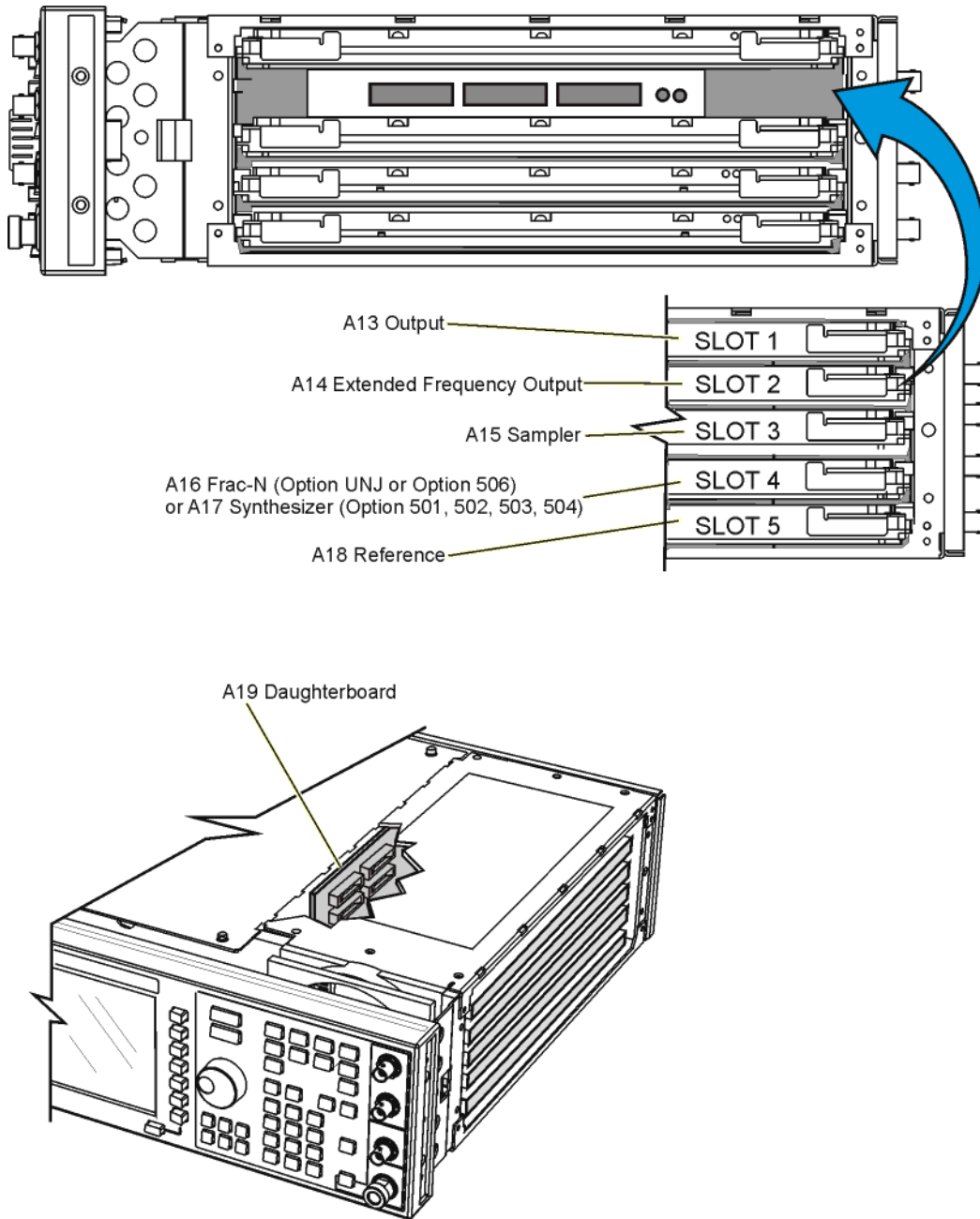

A19 Daughterboard

Tools Required

- T-10 driver

Removal Procedure

Refer to [Figure 3-26](#) for this procedure and to the connector/cable diagram located on the card cage.

1. Disconnect the power cord.
2. Remove the outer and inner-side covers. Refer to [“Outer and Inner Instrument Covers”](#) on page 3-4.

NOTE It is recommended to label the assembly boards before you remove them from the card cage for easy installation.

3. Remove all of the board assemblies from the side-card cage (located on the left side of the signal generator) by lifting the retention levers and disconnecting the assembly boards from the A19 Daughterboard.
4. Using the T-10 driver, remove the five screws that attach the A19 Daughterboard to the signal generator’s chassis.
5. Remove the A19 Daughterboard from the card cage.

Replacement Procedure

1. Reverse the order of the removal procedure.
2. Torque all T-10 screws to 9 in-lbs.
3. Perform the post-repair adjustments and performance tests that pertain to this removal procedure.

Figure 3-26 A19 Daughterboard

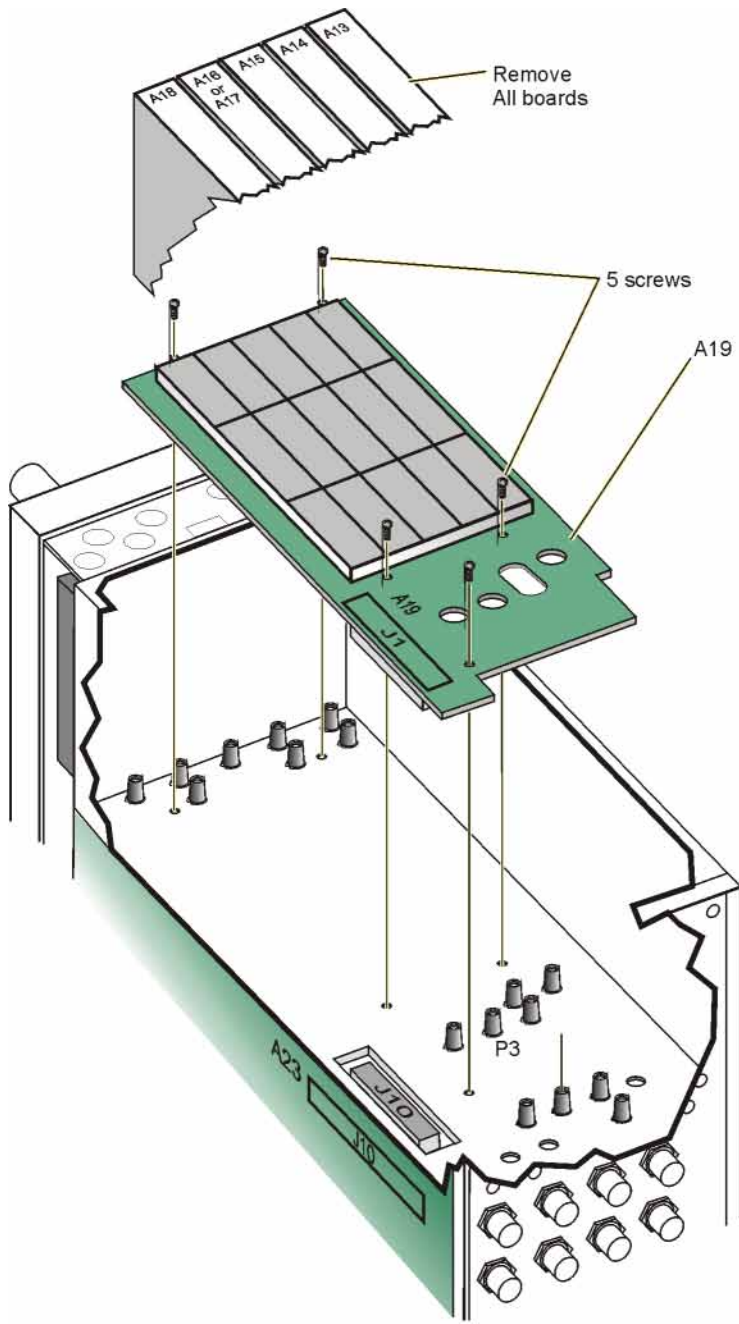

A19 Daughterboard Cable Removal

Tools Required

- external retaining ring pliers

Removal Procedure

Refer to [Figure 3-27](#) for this procedure.

1. Disconnect the power cord.
2. Remove the outer and inner-side covers. Refer to [“Outer and Inner Instrument Covers” on page 3-4](#).

NOTE Before removing assemblies from the card cage, it is recommended that the assembly be labelled. This will help during reassembly.

3. Remove all of the assembly boards from the card cage (located on the left side of the signal generator) by lifting the retention levers and disconnecting the assembly boards from the A19 Daughterboard.
4. Slide-out all of the assembly boards in the card cage.
5. Remove the A19 Daughterboard. Refer to [“A19 Daughterboard” on page 3-48](#).
6. Using the external retaining ring pliers (1), remove the metal retaining rings (2).
7. Remove the cable from the card cage.

Replacement Procedure

1. Reverse the order of the removal procedure.
2. Perform the post-repair adjustments and performance tests that pertain to this removal procedure.

Figure 3-27 A19 Daughterboard Cable Removal

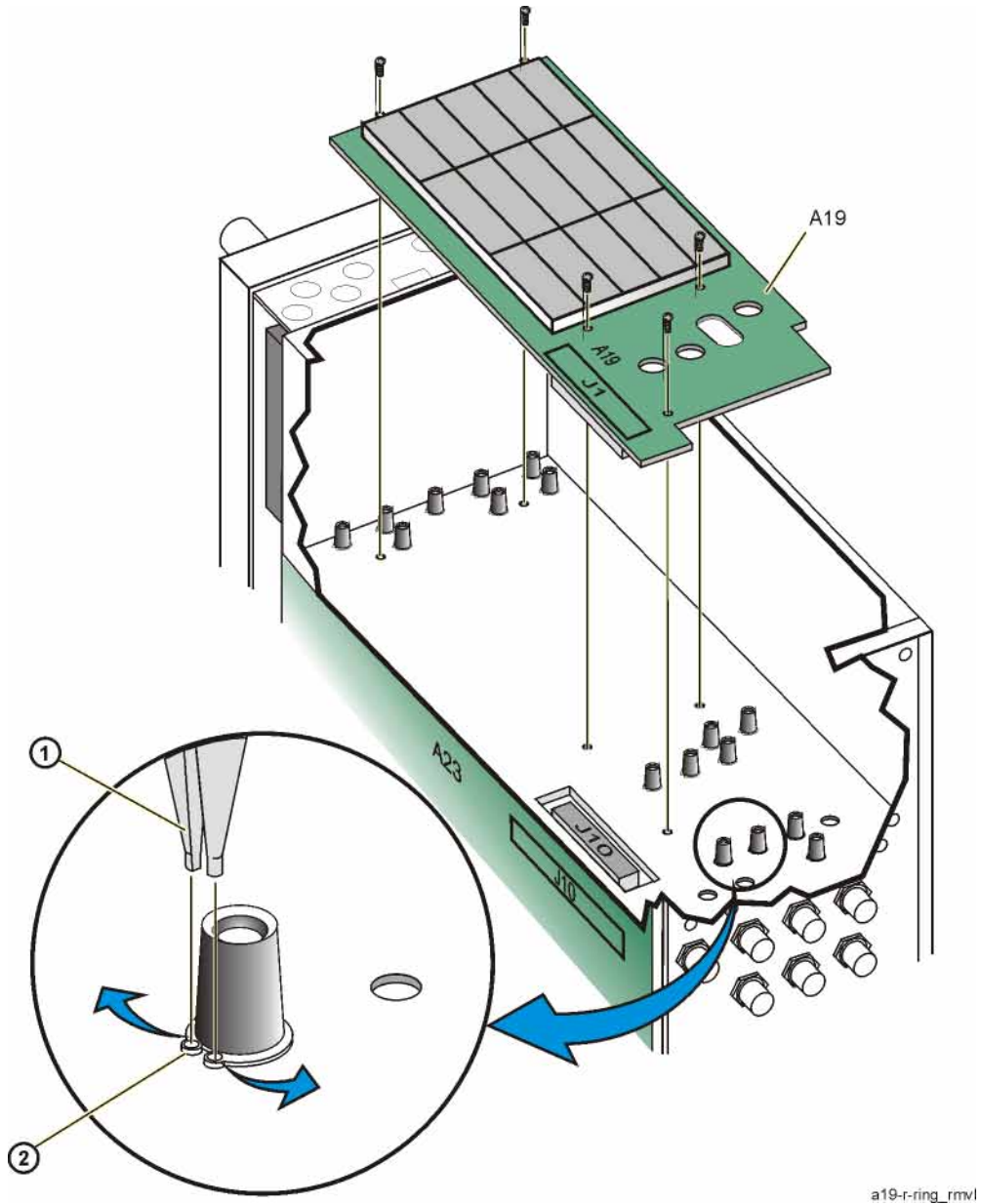

a19-r-ring_rmvl

A20 Downconverter (E4438C Only)

Tools Required

- T-10 driver
- needle-nose pliers

Removal Procedure

Refer to [Figure 3-28](#) for this procedure.

1. Disconnect the power cord.
2. Remove the outer and inner covers. Refer to “[Outer and Inner Instrument Covers](#)” on page 3-4.
3. Using needle-nose pliers, disconnect the following cables from the A20 Downconverter:
 - W64
 - W13
 - W14
4. Disconnect the W63 ribbon cable from A23J19.
5. Using the T-10 driver, remove the two screws (1) from the hook bracket that are holding the A20 Downconverter to the chassis.
6. Tilt the hook bracket away from the chassis and slide out the tabs from the slots. The hook bracket has two hinged tabs at the bottom that fit into slots in the signal generator’s chassis.
7. Using the T-10 driver, remove the four screws (2) that hold the hook bracket to the A20 Downconverter .
8. Remove the A20 Downconverter .

Replacement Procedure

1. Reverse the order of the removal procedure.
2. Torque all T-10 screws to 9 in-lbs.
3. Perform the post-repair adjustments and performance tests that pertain to this removal procedure.

Figure 3-28 A20 Downconverter

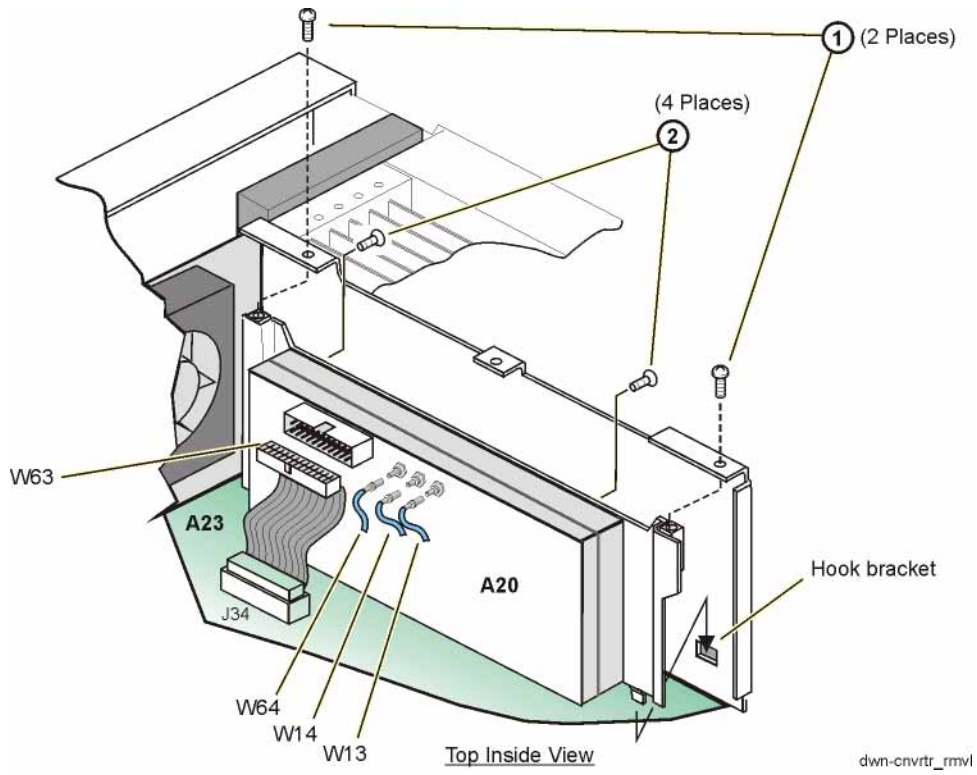

A21 YTO Driver and A22 Coupler

Tools Required

- T-10 driver
- 5/16" open ended wrench
- needle-nose pliers

Removal Procedure

Refer to [Figure 3-29](#) for this procedure.

1. Disconnect the power cord.
2. Remove the outer and inner covers. Refer to “[Outer and Inner Instrument Covers](#)” on page 3-4.
3. Disconnect the W27 ribbon cable from the A21 YTO Driver.
4. Using needle-nose pliers, disconnect the following cables:
 - W28 from A21J3
 - W29 from A21J4
5. Using the 5/16" open ended wrench, disconnect the following RF cables from the A21 YTO Driver:
 - W37
 - W38
 - On signal generators with Option 506:
 - disconnect W56
 - if removing the A22 Coupler:
 - disconnect W55
 - disconnect W54
 - remove the two screws (3) holding the A22 Coupler to the A21 YTO Driver
6. Using the T-10 driver, remove the two screws (1) from the hook bracket that are holding the A21 YTO Driver to the chassis.
7. Tilt the hook bracket away from the chassis and slide out the tabs from the slots. The hook bracket has two hinged tabs at the bottom that fit into slots in the signal generator's chassis.
8. Using the T-10 driver, remove the four screws (2) that hold the hook bracket to the A21 YTO Driver.

Replacement Procedure

NOTE Make sure that the tabs on the A21 YTO Driver hook bracket line up with the slots in the chassis.

1. Reverse the order of the removal procedure.
2. Torque all T-10 screws to 9 in-lbs.
3. Torque all RF connectors to 9 in-lbs.
4. Perform the post-repair adjustments and performance tests that pertain to this removal procedure.

Figure 3-29 A21 YTO Driver

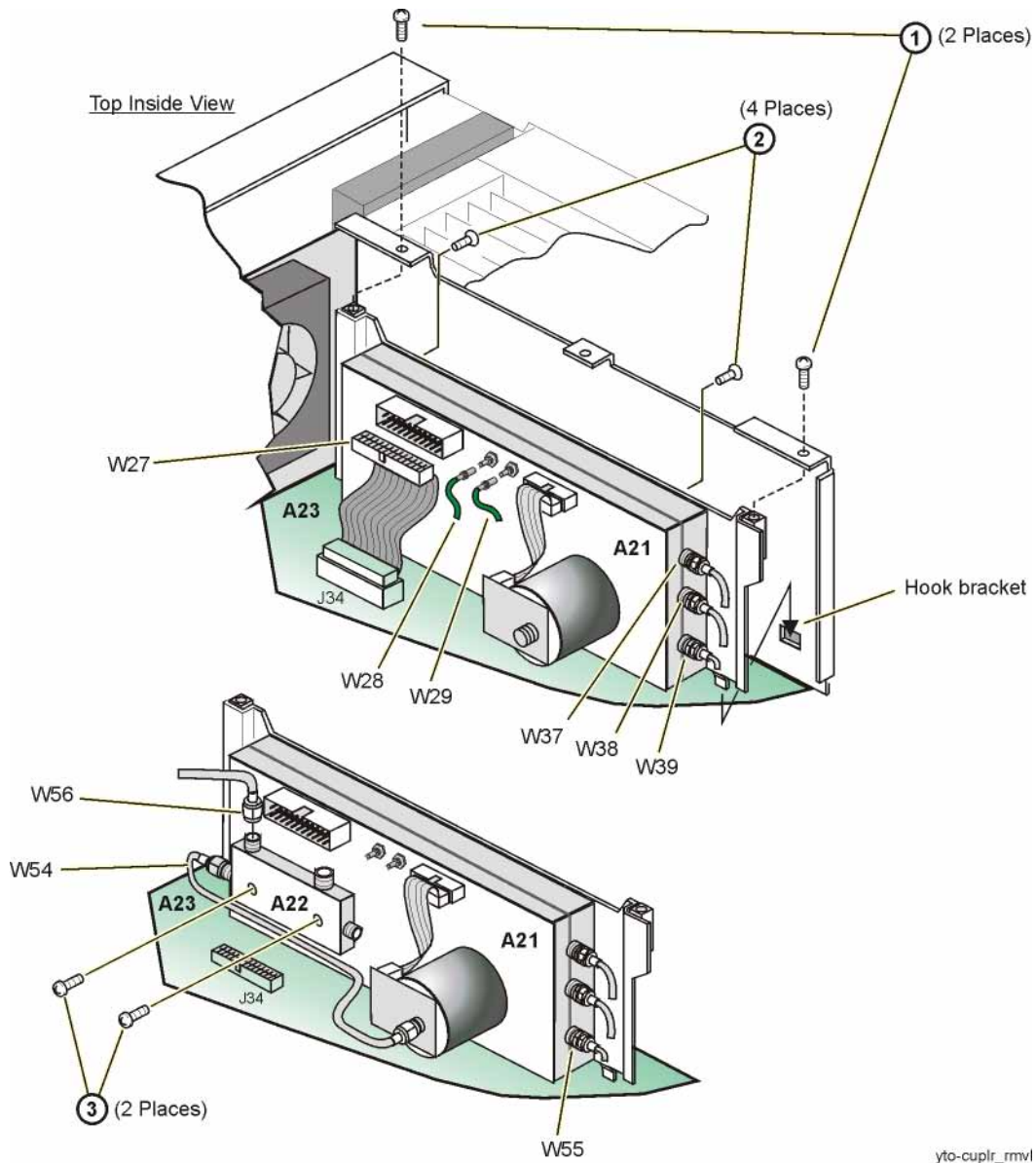

yto-cuplr_rmv1

A23 Motherboard

Tools Required

- T-10 driver
- 5/8" open-ended wrench
- 3/16" nut driver
- 9/32" nut driver
- needle-nose pliers

Removal Procedure

Refer to [Figure 3-30](#) for this procedure.

1. Disconnect the power cord.
2. Remove the outer and top inner covers. Refer to [“Outer and Inner Instrument Covers”](#) on page 3-4.
3. Remove the A6 Power Supply. Refer to [“A6 Power Supply”](#) on page 3-24.
4. Remove all of the assembly boards inserted into the A23 Motherboard. For cable removal, refer to [“A12 CPU”](#) on page 3-34.
5. Remove the following cables from the A23 Motherboard:
 - W27 ribbon cable from A23J34
 - W63 ribbon cable from A23J26 (E4438C only)
 - W40 ribbon cable from A23J25 (for instruments with an AT1 Electronic Attenuator)
W57 ribbon cable from A23J25 (for instruments with an AT1 High-Power Mechanical Attenuator — Option UNB)
 - W32 wire cable from A23J36 (E4438C only)
 - W31 from A23J20, using the needle-nose pliers
 - B1W1 fan cable from A23J33
 - B2W1 fan cable from A23J27
 - B3W1 fan cable from A23J29
6. Using the 3/16" nut driver, remove the shoulder nuts (2) and washers (1) on the RS-232 connector.
7. Using the 5/8" open-ended wrench, remove the nuts (3) and washers (4) from the 10 MHz OUT, 10 MHz IN, TRIG IN, and TRIG OUT.
8. Using the 9/32" nut driver, remove the shoulder nuts (5) and washers (6) on the GPIB connector.
9. Using the T-10 driver, remove the eight screws (7) on the Rear Panel (8).
10. Using the T-10 driver, remove the five screws (9) that hold the A23 Motherboard to the chassis.
11. Using the T-10 driver, remove the four screws (10) that hold the bottom rib (11) to the A23 Motherboard.
12. Gently pry out the Rear Panel, guide out the BNCs, and remove the A23 Motherboard from the chassis.

Replacement Procedure

1. Reverse the order of the removal procedure.
2. Torque all T-10 screws to 9 in-lbs.
3. Torque all RF connectors to 9 in-lbs.
4. Torque all 5/8" nuts to 9 in-lbs.
5. Torque all 5/16" nuts to 9 in-lbs.
6. Power-on the instrument.
7. Restore the system information from the CPU to the backup directory of the new motherboard:

Execute the SCPI command :DIAG:FILE:BACK.

Or

From the front panel, press **Utility > Instrument Adjustments > Service Adjustments > Backup System Files**.

8. Perform the post-repair adjustments and performance tests that pertain to this removal procedure.

Figure 3-30 **A23 Motherboard**

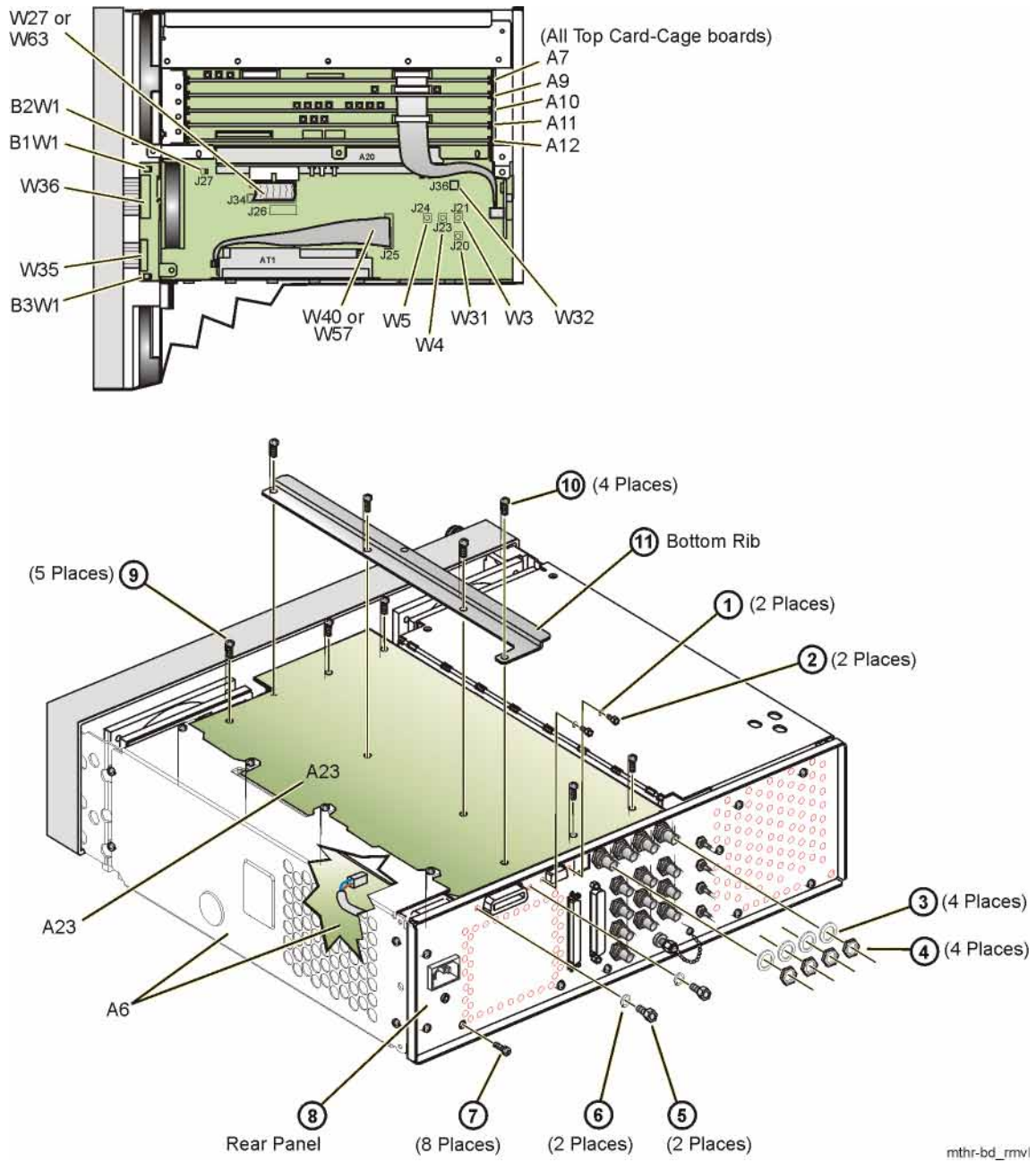

A23BT1 Battery

Tools Required

- none

Removal Procedure

Refer to [Figure 3-31](#) for this procedure.

1. Disconnect the power cord.
2. Remove the outer cover. Refer to “[Outer and Inner Instrument Covers](#)” on page 3-4.
3. Place the signal generator on its side so that the bottom of the signal generator is visible.
4. Remove the battery.

Replacement Procedure

1. Reverse the order of the removal procedure, but pay special attention when replacing the battery; angle the left-side of the battery so that it goes under the positive prongs before pushing it down.
2. Perform the post-repair adjustments and performance tests that pertain to this removal procedure.

Figure 3-31 **A23BT1 Battery**

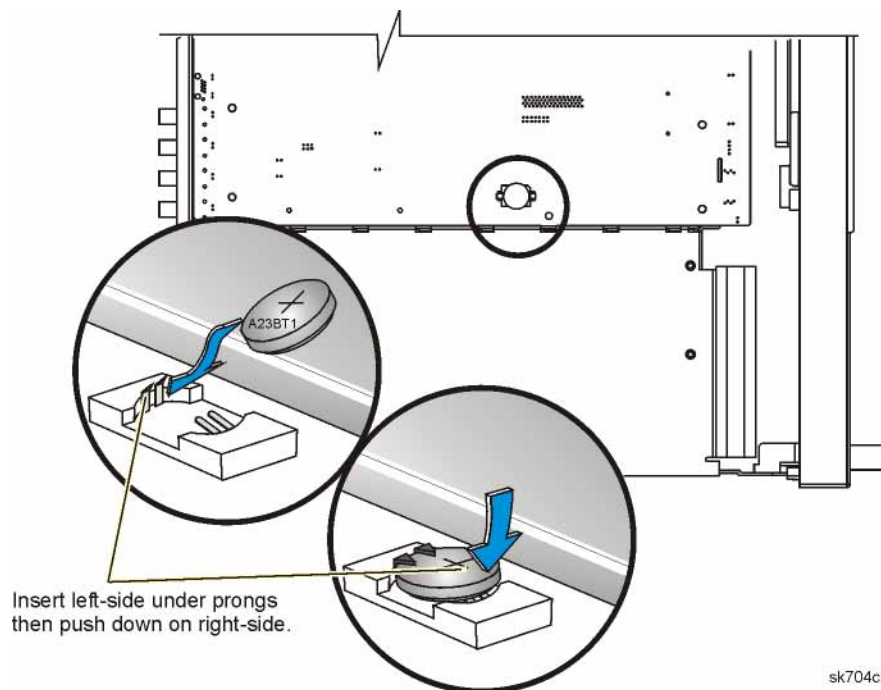

A24 Line Module

Tools Required

- T-10 driver

Removal Procedure

Refer to [Figure 3-32](#) for this procedure.

1. Disconnect the power cord.
2. Remove the outer cover. Refer to [“Outer and Inner Instrument Covers”](#) on page 3-4.
3. Remove the Rear Panel. Refer to [“Rear Panel”](#) on page 3-62.
4. Using a T-10 driver, remove the screw (2) that secures the A24 Line Module (1) to the Rear Panel.
5. Remove the A24 by pulling the metal tab at the top of the line module, and at the same time, pushing up at the bottom of the line module to release it from the rear panel.

Replacement Procedure

1. Reverse the order of the removal procedure.
2. Torque all T-10 screws to 9 in-lbs.
3. Perform the post-repair adjustments and performance tests that pertain to this removal procedure.

Figure 3-32 A24 Line Module

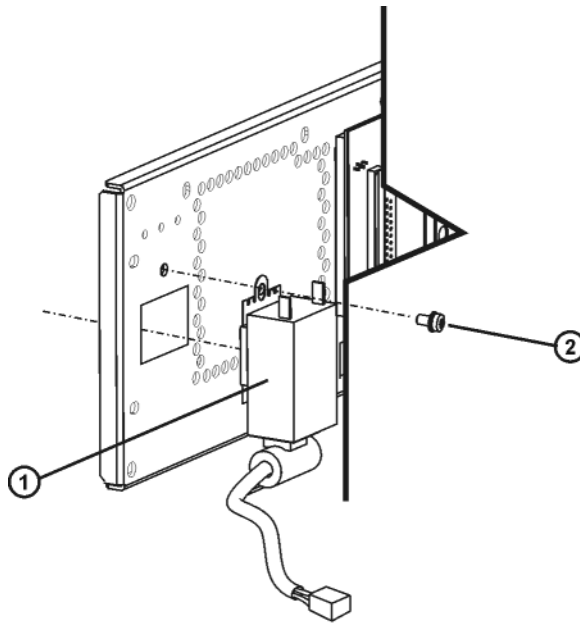

sk758c

Rear Panel

Tools Required

- T-10 driver
- 5/8" hex-nut driver
- 9/32" nut driver
- 3/16" nut driver
- needle-nose pliers

Removal Procedure

Refer to [Figure 3-33](#) and [Figure 3-34](#) for this procedure.

1. Disconnect the power cord.
2. Remove the outer cover. Refer to [“Outer and Inner Instrument Covers”](#) on page 3-4.
3. Disconnect all cables connected to the Rear Panel.
4. Using the 9/32" nut driver, remove the nuts on the GPIB connector (1).
5. Using the 3/16" nut driver, remove the nuts on the RS-232 connector (2).
6. Using the 5/8" hex-nut driver, remove the nuts and washers from the 10 MHz OUT, 10 MHz IN, TRIG IN, and TRIG OUT (3).

NOTE Do not remove the screw that secures the chain and cap for the COH CARRIER.

7. Using the T-10 driver, remove the eight screws (4) from the Rear Panel.
8. Using the T-10 driver, remove the 13 screws (5) from the A6 Power Supply's shielding.
9. Disconnect the A24W1 (6) from the A6 Power Supply.
10. Remove the Rear Panel from the chassis.

Replacement Procedure

1. Reverse the order of the removal procedure.
2. Torque the GPIB hex screw to 9 in-lb.
3. Torque the RS-232 hex screw to 6 in-lb.
4. Torque all T-10 screws to 9 in-lbs.
5. Torque all BNC nuts to 21 in-lbs.
6. Perform the post-repair adjustments and performance tests that pertain to this removal procedure.

Figure 3-33 Rear Panel (E4428C)

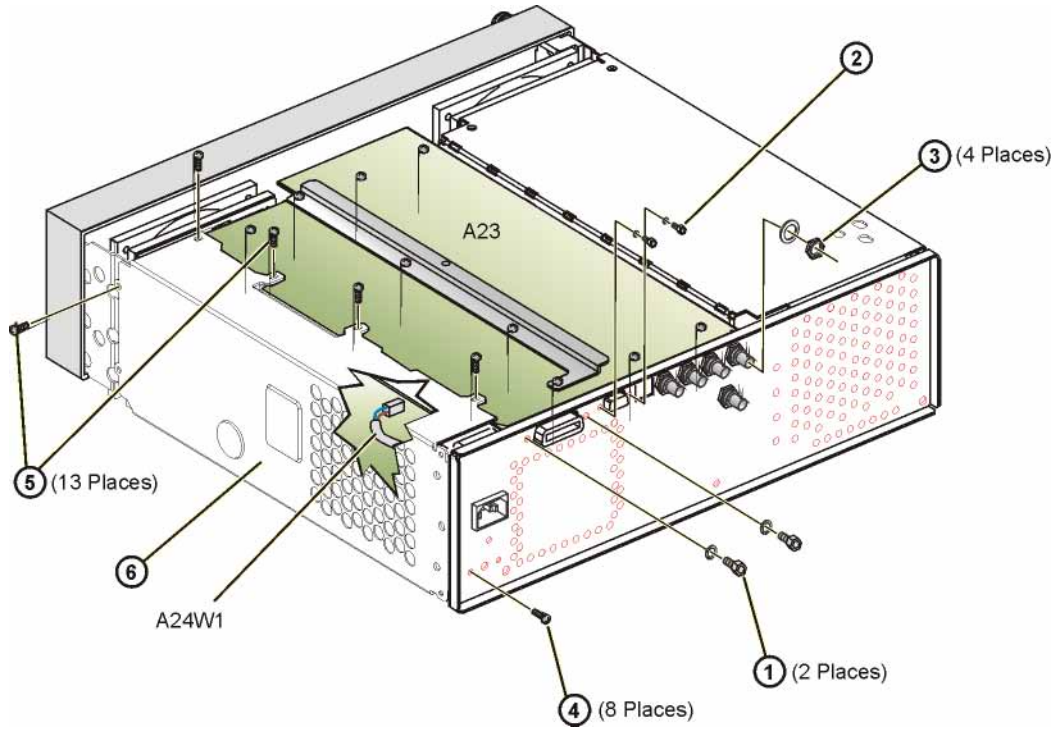
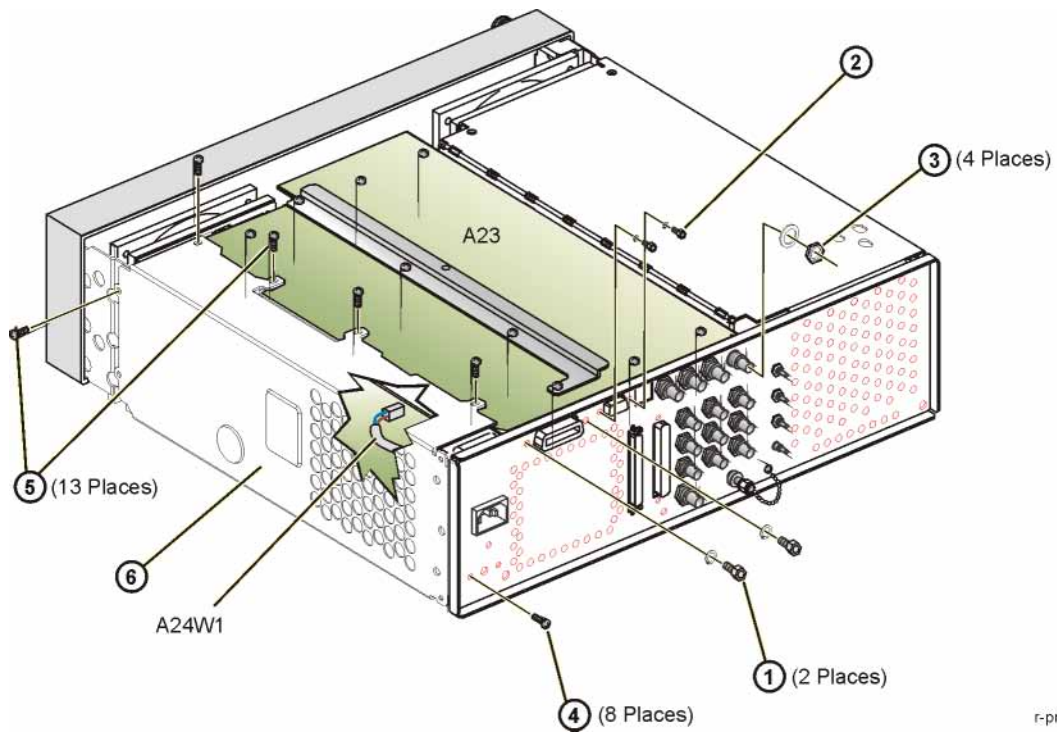

Figure 3-34 Rear Panel (E4438C)



r-pnl_rmw

A25 Rear Panel Board (E4438C Only)

Tools Required

- T-10 driver
- 3/16" hex-nut driver
- 9/16" open-ended wrench
- 5 mm nut driver
- small phillips screw driver

Removal Procedure

Refer to [Figure 3-35](#) for this procedure.

1. Disconnect the power cord.
2. Remove the outer cover. Refer to [“Outer and Inner Instrument Covers”](#) on page 3-4.
3. Disconnect W10 from the A25 Rear Panel Board.
4. Disconnect W32 from the A25 Rear Panel Board.
5. Using the T-10 driver, remove the two screws (1) from the Digital Bust Retainer.
6. Disconnect W92 from P1 on the A25 Rear Panel Board.
7. Using the 9/16" open-ended wrench, remove the nuts on the EVENT 1, EVENT 2, PATT TRIG IN, BURST GATE IN, connectors (2).
8. Using the 5 mm nut driver, remove the shoulder nuts and washers from the AUX I/O connector (3).
9. Using a small phillips screw driver, remove the two screws from the DIG I/Q I/O connector (4).
10. Remove the A25 Rear Panel Board from the chassis.

Replacement Procedure

1. Reverse the order of the removal procedure.
2. Torque all T-10 screws to 9 in-lbs.
3. Torque all BNC nuts to 21 in-lbs.
4. Perform the post-repair adjustments and performance tests that pertain to this removal procedure.

Figure 3-35

A25 Rear Panel Board

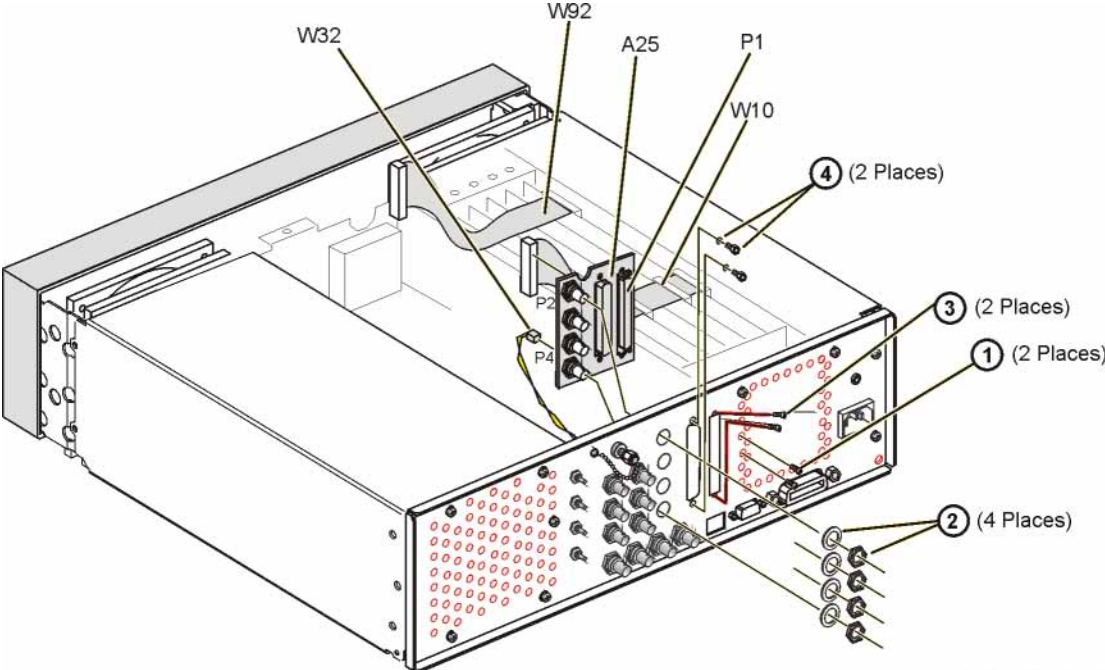

a25-opt601_2_rmv1

A26 Rear Panel LVDS Board (Option 1EM — E4438C Only) and A27 Rear Panel SMB Board (Option 1EM — E4438C Only)

Tools Required

- T-10 driver
- 5/8" hex-nut driver
- 3/16" hex-nut driver
- 9/16" open-ended wrench
- 5 mm nut driver
- needle-nose pliers

Removal Procedure

Refer to [Figure 3-36](#) for this procedure.

1. Disconnect the power cord.
2. Remove the outer cover. Refer to [“Outer and Inner Instrument Covers” on page 3-4](#).
3. Disconnect all cables connected to the A26 Rear Panel LVDS Board and A27 Rear Panel SMB Board.
4. Using the 9/16" open-ended wrench, remove the nuts (1) on the A27 Rear Panel SMB Board.
5. Using a small phillips screw driver, remove the two screws (2) from the A26 Rear Panel LVDS Board.
6. Using the 5 mm nut driver, remove the shoulder screws (3) from the A26 Rear Panel LVDS Board.
7. Remove the A26 Rear Panel LVDS Board and A27 Rear Panel SMB Board from the chassis.

Replacement Procedure

1. Reverse the order of the removal procedure.
2. Torque the GPIB hex screw to 9 in-lb.
3. Torque the RS-232 hex screw to 6 in-lb.
4. Torque all T-10 screws to 9 in-lbs.
5. Torque all BNC nuts to 21 in-lbs.
6. Perform the post-repair adjustments and performance tests that pertain to this removal procedure.

A26 Rear Panel LVDS Board (Option 1EM — E4438C Only) and A27 Rear Panel SMB Board (Option 1EM — E4438C Only)

Figure 3-36 **A26 Rear Panel LVDS Board
and A27 Rear Panel SMB Board**

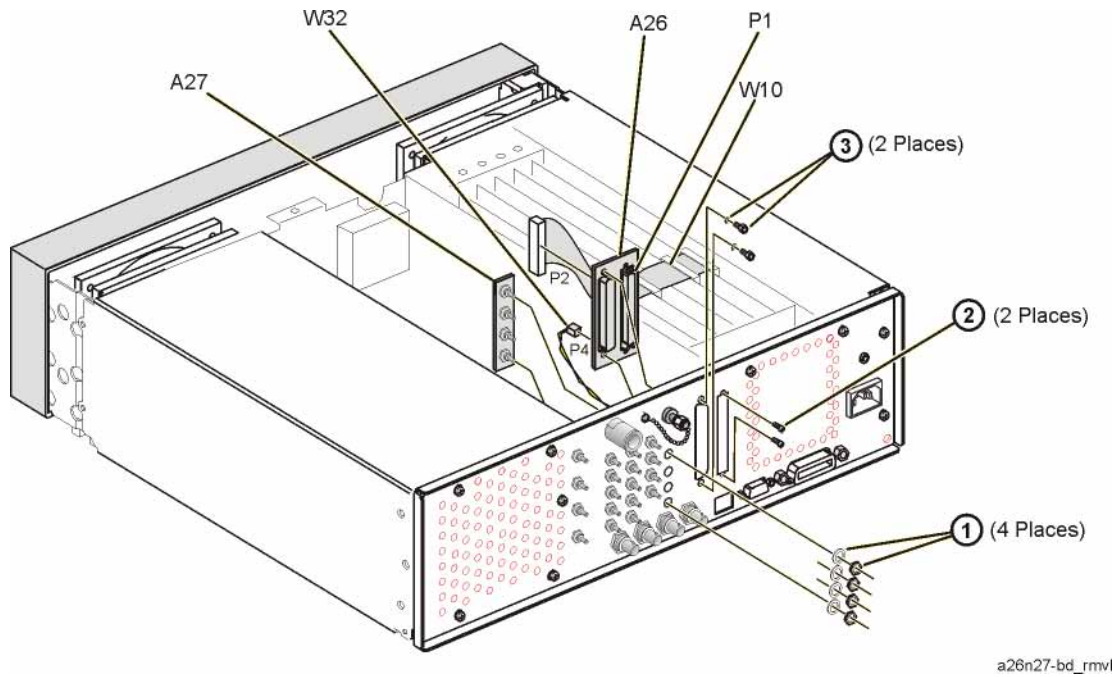

AT1 High-Power Mechanical Attenuator with A28 Reverse Power Protection

Tools Required

- T-10 driver
- 5/16" open ended wrench

Removal Procedure

Refer to [Figure 3-37](#) for this procedure.

1. Disconnect the power cord.
2. Remove the outer and top inner cover. Refer to [“Outer and Inner Instrument Covers” on page 3-4](#).
3. Using the 5/16" open ended wrench, disconnect the following cables:
 - W47
 - W48
 - W49
 - On signal generators with Option 1EM, disconnect W86. (Refer to [“Option 1EM Semi-Rigid Cables - Includes the AT1 Electronic Attenuator or the AT1 High-Power Mechanical Attenuator \(Option UNB\) with the A28 Reverse Power Protection” on page 2-38](#).)
4. Disconnect W57 from A23J25.
5. Disconnect W53 from A23J22.
6. Using the T-10 driver, remove the two screws (1) from the AT1 bracket that secures the AT1 High-Power Mechanical Attenuator and the A28 Reverse Power Protection to the chassis.
7. Tilt the AT1 bracket away from the chassis and slide out the tabs from the slots. There are two hinged tabs at the bottom of the AT1 bracket that fit into slots in the signal generator's chassis.
8. Using the T-10 driver remove the four screws (2) that attach the RPP bracket to the AT1 bracket.
9. Using the T-10 driver remove the four screws (3) that attach the AT1 High-Power Mechanical Attenuator to the AT1 bracket.
10. Using the T-10 driver remove the three screws (4) that attach the A28 Reverse Power Protection to the RPP bracket.
11. Remove the A28 Reverse Power Protection.

Replacement Procedure

1. Reverse the order of the removal procedure.
2. Torque all T-10 screws to 9 in-lbs.
3. Torque all RF cables to 9 in-lbs.
4. Perform the post-repair adjustments and performance tests that pertain to this removal procedure.

AT1 High-Power Mechanical Attenuator with A28 Reverse Power Protection

Figure 3-37

AT1 High-Power Mechanical Attenuator with A28 Reverse Power Protection

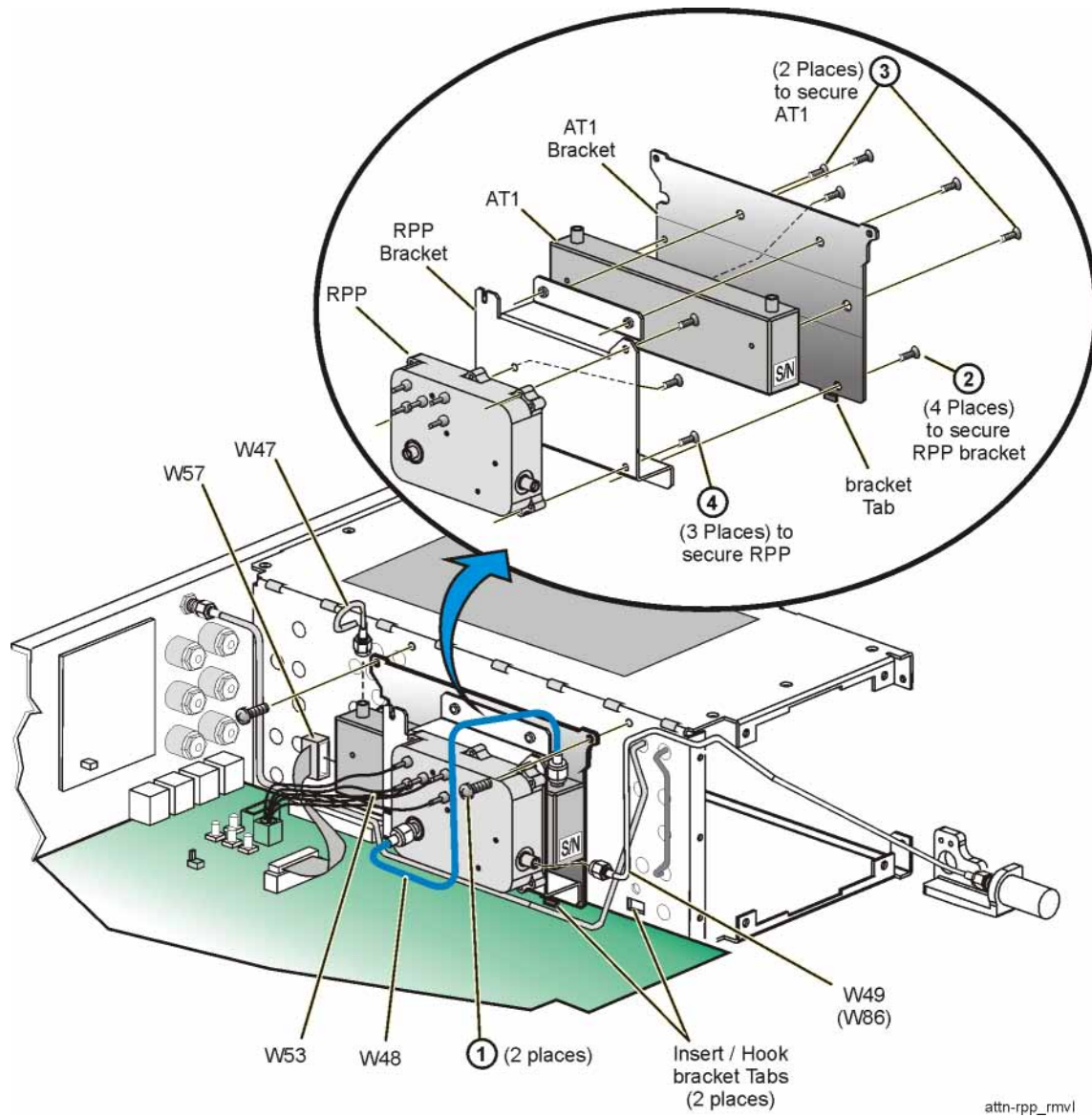

AT1 High-Power Mechanical Attenuator

NOTE On signal generators equipped with an RPP, refer to [“AT1 High-Power Mechanical Attenuator with A28 Reverse Power Protection” on page 3-68](#) for removal instructions. The following procedure is primarily for Option 506.

Tools Required

- T-10 driver
- 5/16” open ended wrench

Removal Procedure

Refer to [Figure 3-38](#) for this procedure.

1. Disconnect the power cord.
2. Remove the outer and inner covers. Refer to [“Outer and Inner Instrument Covers” on page 3-4](#).
3. On signal generators equipped with an RPP, refer to [“AT1 High-Power Mechanical Attenuator with A28 Reverse Power Protection” on page 3-68](#) for removal instructions.
4. Using the 5/16” open ended wrench:
 - disconnect W50
 - disconnect W59
 - On signal generators with Option 1EM, disconnect W91. (Refer to [“Option 1EM Semi-Rigid Cables - Includes the A21 YTO Driver and the AT1 High-Power Mechanical Attenuator \(Option UNB\) with an A29 DC Blocking Capacitor” on page 2-64](#).)
5. Disconnect W57 from A23J25.
6. Using the T-10 driver, remove the two screws (1) that attach the AT1 High-Power Mechanical Attenuator to the chassis.
7. Tilt the AT1 bracket away from the chassis and slide out the tabs from the slots. There are two hinged tabs at the bottom of the AT1 bracket that fit into slots in the signal generator’s chassis.
8. Using the T-10 driver, remove the two screws (2) that attach the AT1 bracket to the AT1 High-Power Mechanical Attenuator.
9. Remove the AT1 High-Power Mechanical Attenuator.

Replacement Procedure

1. Reverse the order of the removal procedure.
2. Torque all T-10 screws to 9 in-lbs.
3. Torque all RF connectors to 8 in-lbs.
4. Perform the post-repair adjustments and performance tests that pertain to this removal procedure.

Figure 3-38 AT1 High-Power Mechanical Attenuator

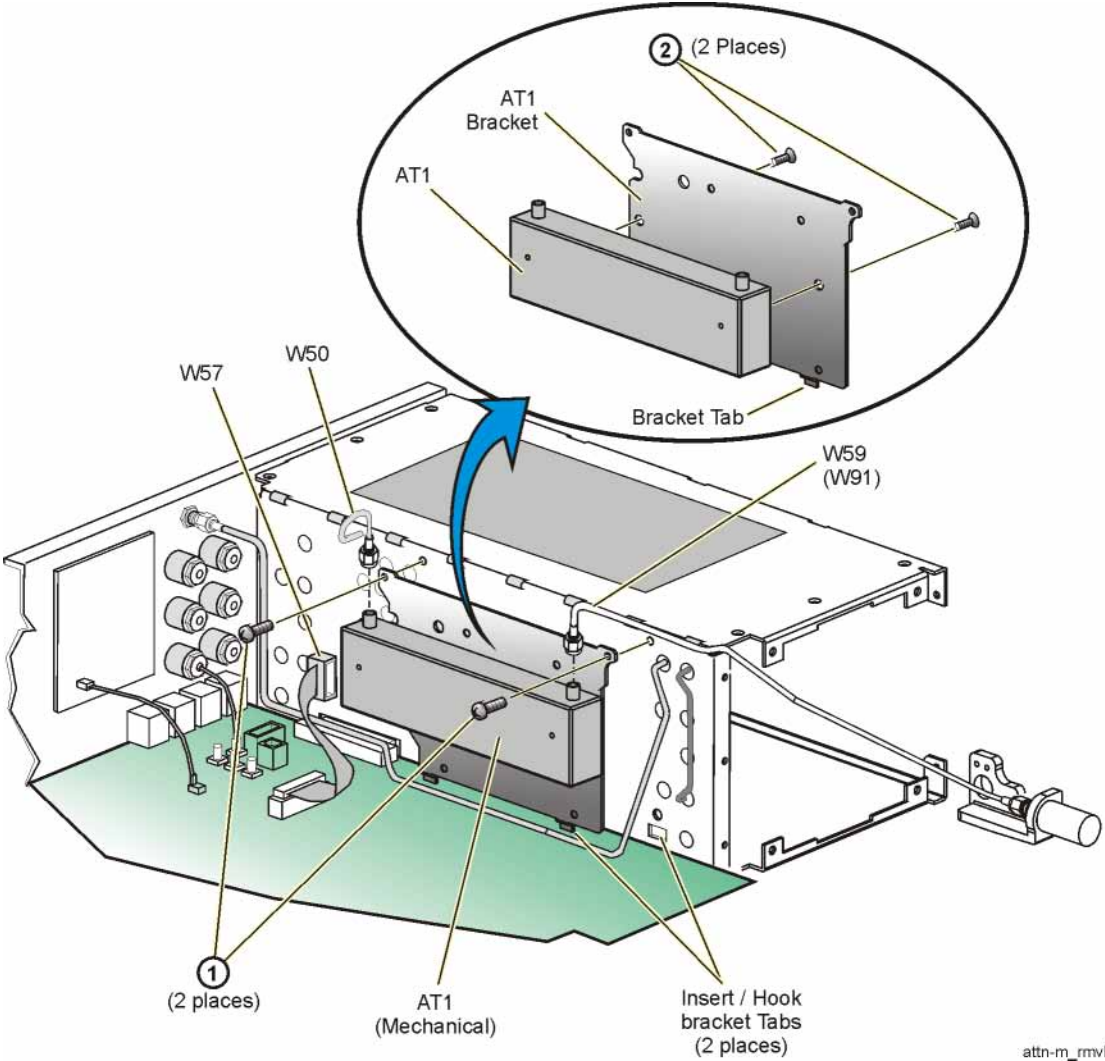

attn-m_rmv

AT1 Electronic Attenuator

Tools Required

- T-10 driver
- 5/16" open ended wrench

Removal Procedure

Refer to [Figure 3-39](#) for this procedure.

1. Disconnect the power cord.
2. Remove the outer and inner covers. Refer to [“Outer and Inner Instrument Covers” on page 3-4](#).
3. Using the 5/16" open ended wrench:
 - disconnect W43
 - disconnect W9

On signal generators with Option 1EM, disconnect W85. (Refer to [“Option 1EM Semi-Rigid Cables - Includes the AT1 Electronic Attenuator or the AT1 High-Power Mechanical Attenuator \(Option UNB\) with the A28 Reverse Power Protection” on page 2-38](#).)

4. Using the T-10 driver, remove the two screws (1) that attach the AT1 Electronic Attenuator to the chassis.
5. Disconnect W40 from A23J25.
6. Remove the AT1 Electronic Attenuator by leaning it forward and guiding out the hinged tabs located at the bottom of the bracket.
7. Using the T-10 driver, remove the three screws that attach the sheet metal to the AT1 Electronic Attenuator.

Replacement Procedure

1. Reverse the order of the removal procedure.
2. Torque all T-10 screws to 9 in-lbs.
3. Torque all RF connectors to 8 in-lbs.
4. Perform the post-repair adjustments and performance tests that pertain to this removal procedure.

Figure 3-39 AT1 Electronic Attenuator

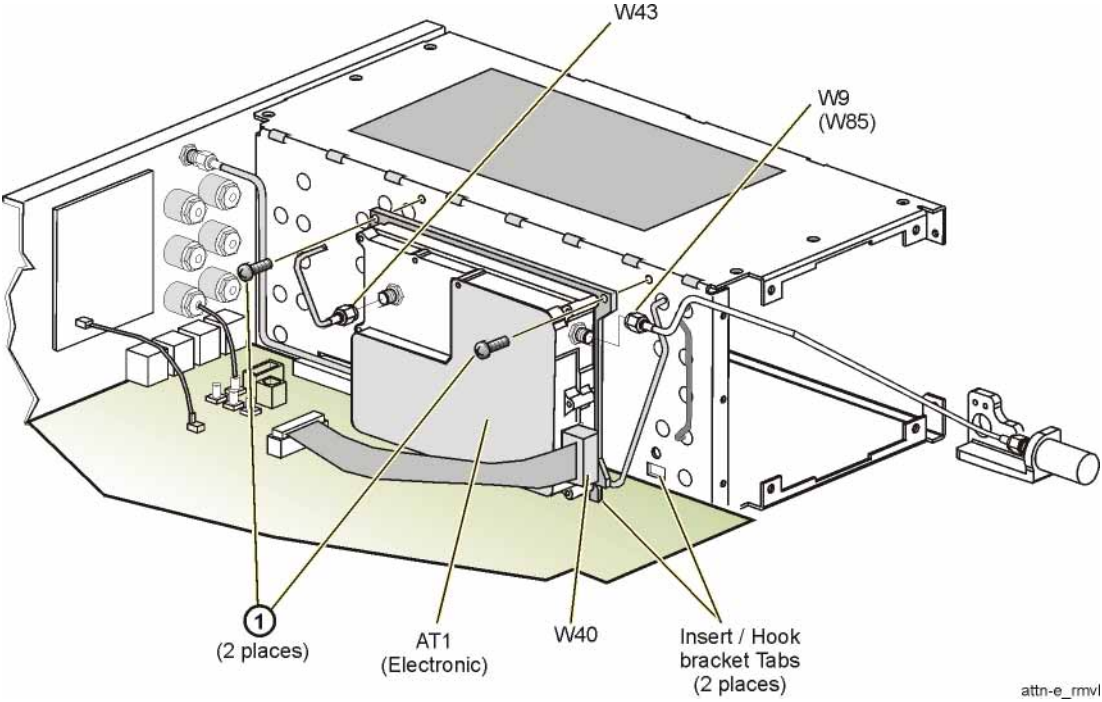

A29 DC Blocking Capacitor

Tools Required

- 5/16" open ended wrench

Removal Procedure

Refer to [Figure 3-40](#) for this procedure.

1. Disconnect the power cord.
2. Remove the outer and top inner cover. Refer to [“Outer and Inner Instrument Covers” on page 3-4](#).
3. Remove the front panel. Refer to [“Front Panel” on page 3-6](#).
4. Using the 5/16" open ended wrench, disconnect W59 from the A29 DC Blocking Capacitor.
5. Using the 5/16" open ended wrench, disconnect A29 DC Blocking Capacitor from W60.
6. Remove the A29 DC Blocking Capacitor.

Removal Procedure for Option 1EM

Refer to [Figure 3-41](#) for this procedure.

1. Disconnect the power cord.
2. Remove the outer and top inner cover. Refer to [“Outer and Inner Instrument Covers” on page 3-4](#).
3. Using the 5/16" open ended wrench, disconnect W91 from the A29 DC Blocking Capacitor.
4. Using the 5/16" open ended wrench, disconnect A29 DC Blocking Capacitor from the RF Output connector.
5. Remove the A29 DC Blocking Capacitor.

Replacement Procedure

1. Reverse the order of the removal procedure.
2. Torque all RF cables to 9 in-lbs.
3. Perform the post-repair adjustments and performance tests that pertain to this removal procedure.

Figure 3-40 A29 DC Blocking Capacitor

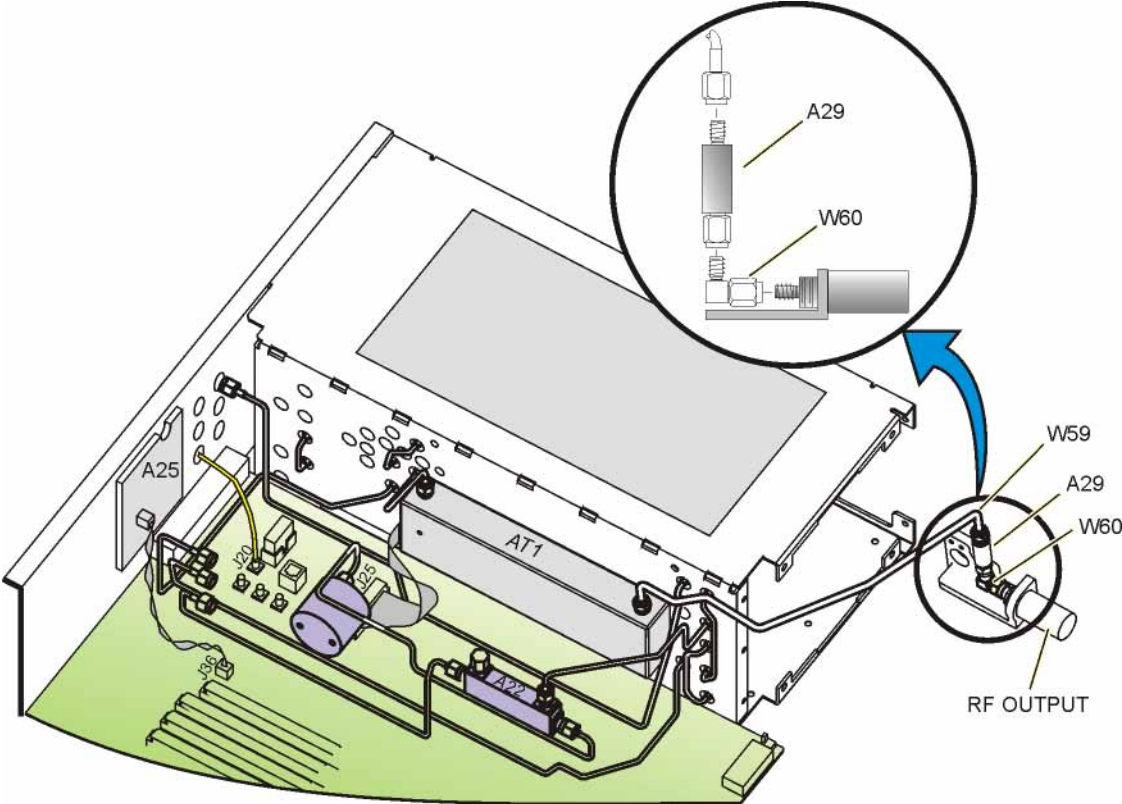

dc-blk-fp_rmv1

Figure 3-41 A29 DC Blocking Capacitor, for Option 1EM

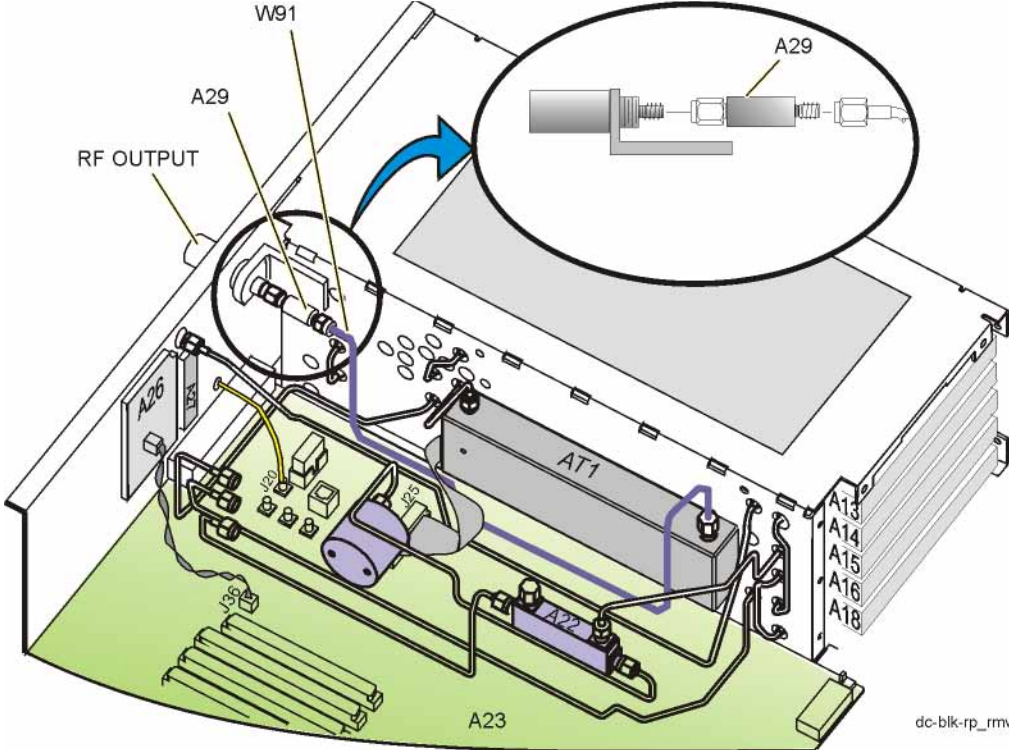

dc-blk-rp_rmv1

B1 Power Supply Fan

Tools Required

- T-10 driver

Removal Procedure

Refer to [Figure 3-42](#) for this procedure.

1. Disconnect the power cord.
2. Remove the outer cover. Refer to [“Outer and Inner Instrument Covers”](#) on page 3-4.
3. Remove the front panel. Refer to [“Front Panel”](#) on page 3-6.
4. Remove the four screws (1) that attach the B1 Power Supply Fan to the chassis using a T-10 driver.
5. Disconnect the B1W1 fan cable from the A23J33.
6. Remove the B1 Power Supply Fan.

Replacement Procedure

1. Reverse the order of the removal procedure.
2. Torque all T-10 screws to 9 in-lbs.
3. Perform the post-repair adjustments and performance tests that pertain to this removal procedure.

Figure 3-42 B1 Power Supply Fan

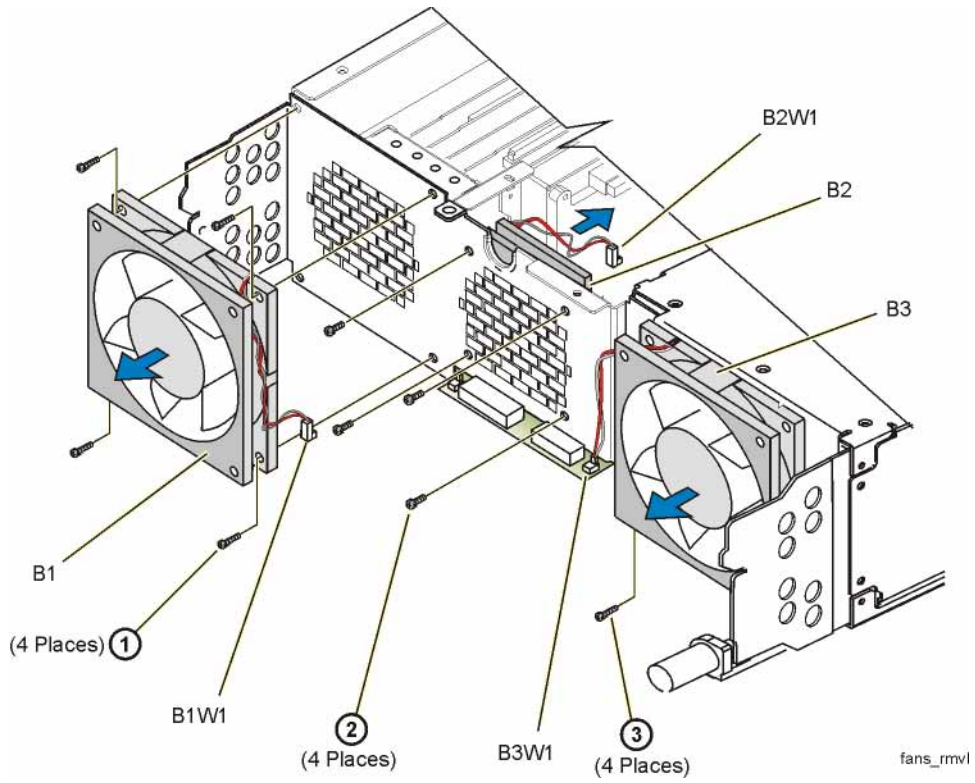

B2 Small Fan

Tools Required

- T-10 driver

Removal Procedure

Refer to [Figure 3-43](#) for this procedure.

1. Disconnect the power cord.
2. Remove the outer and inner covers. Refer to [“Outer and Inner Instrument Covers”](#) on page 3-4.
3. Remove the front panel. Refer to [“Front Panel”](#) on page 3-6.
4. Remove the four screws (2) that attach the B2 Small Fan to the chassis using a T-10 driver.
5. Disconnect the B2W1 fan cable from the A23J27.
6. Remove the B2 Small Fan.

Replacement Procedure

1. Reverse the order of the removal procedure.
2. Torque all T-10 screws to 9 in-lbs.
3. Perform the post-repair adjustments and performance tests that pertain to this removal procedure.

Figure 3-43

B2 Small Fan

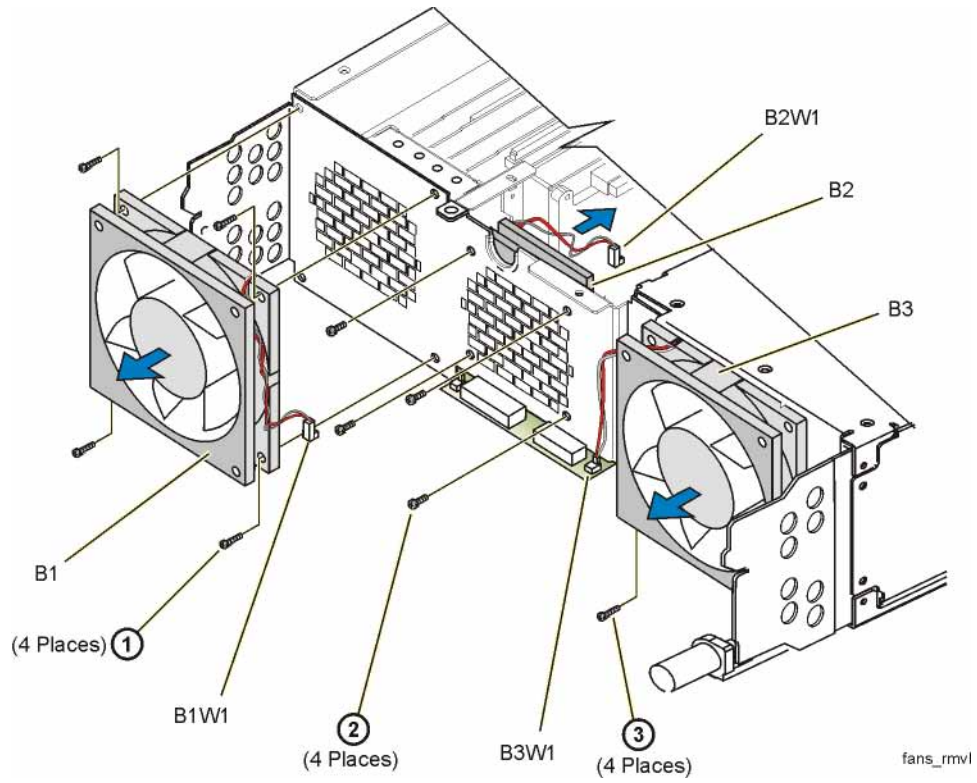

B3 Daughterboard/Card Cage Fan

Tools Required

- T-10 driver

Removal Procedure

Refer to [Figure 3-44](#) for this procedure.

1. Disconnect the power cord.
2. Remove the outer and inner covers. Refer to [“Outer and Inner Instrument Covers”](#) on page 3-4.
3. Remove the front panel. Refer to [“Front Panel”](#) on page 3-6.
4. Remove the four screws (3) that attached the B3 Daughterboard/Card Cage Fan to the chassis using a T-10 driver.
5. Disconnect the B3W1 fan cable from the A23J29.
6. Remove the B3 Daughterboard/Card Cage Fan.

Replacement Procedure

1. Reverse the order of the removal procedure.
2. Torque all T-10 screws to 9 in-lbs.
3. Perform the post-repair adjustments and performance tests that pertain to this removal procedure.

Figure 3-44 B3 Daughterboard/Card Cage Fan

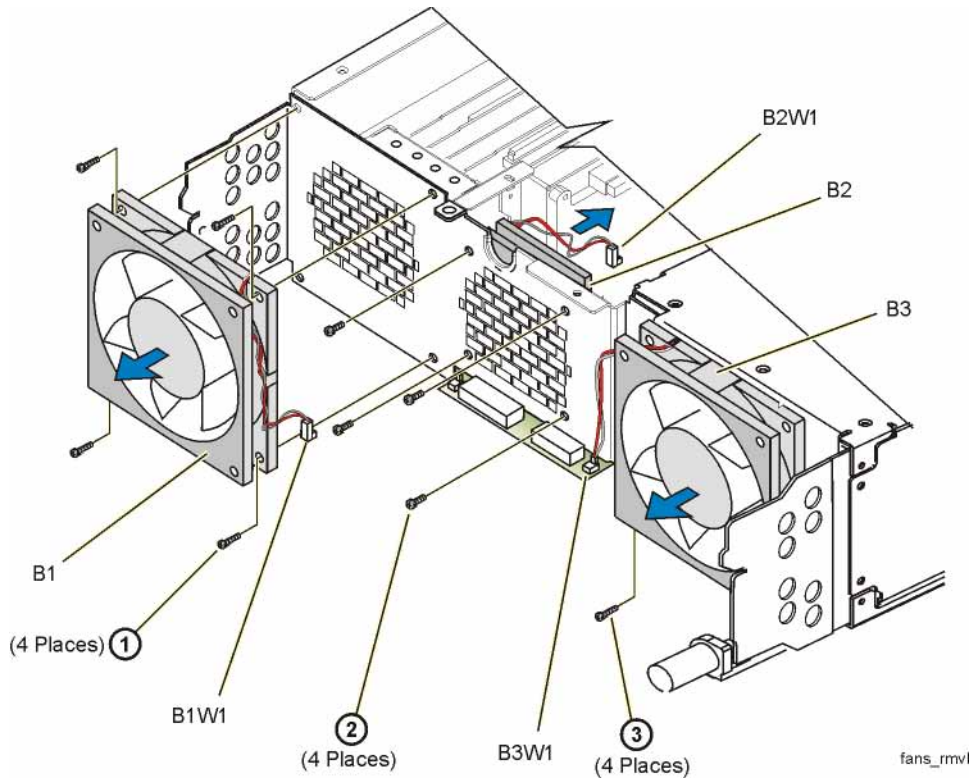

RF Output Connector

Tools Required

- 5/16" open ended wrench
- 9/16" open ended wrench
- T-10 driver

Removal Procedure

Refer to [Figure 3-45](#) for this procedure.

1. Disconnect the power cord.
2. Remove the outer and top inner cover. Refer to [“Outer and Inner Instrument Covers” on page 3-4](#).
3. Remove the front panel. Refer to [“Front Panel” on page 3-6](#).
4. On signal generators:
 - with Option 501, 502, 503, 504 or Option UNJ, using the 5/16" open ended wrench:
 - disconnect W9 from the RF Output Connector
 - with Option 506, using the 5/16" open ended wrench:
 - disconnect W59 from the A29 DC Blocking Capacitor
 - disconnect A29 DC Blocking Capacitor from W60
 - disconnect W60 from the RF Output Connector
5. Using the T-10 driver, remove the two screws (1) that hold the RF Output Connector and bracket (2) to the chassis; they are replaced as one assembly.

Removal Procedure for Option 1EM

Refer to [Figure 3-46](#) for this procedure.

1. Disconnect the power cord.
2. Remove the outer and top inner cover. Refer to [“Outer and Inner Instrument Covers” on page 3-4](#).
3. Remove the rear-panel chassis-support bracket. (From a top view, this covers the RF Output Connector.)
4. On signal generators:
 - with Option 501, 502, 503, 504 or Option UNJ, using the 5/16" open ended wrench:
 - disconnect W85 from the RF Output Connector
 - with Option 506, using the 5/16" open ended wrench:
 - disconnect W91 from the A29 DC Blocking Capacitor
 - disconnect A29 DC Blocking Capacitor from the RF Output Connector
5. Using the T-10 driver, remove the two screws (1) that hold the RF Output Connector and bracket to the chassis.

- Using the 9/16" open ended wrench, remove the nut and washer holding the RF Output Connector to the bracket (2); the bracket does not need to be replaced.

Replacement Procedure

- Reverse the order of the removal procedure.
- Torque all RF cables to 9 in-lbs.
- Perform the post-repair adjustments and performance tests that pertain to this removal procedure.

Figure 3-45 RF Output Connector

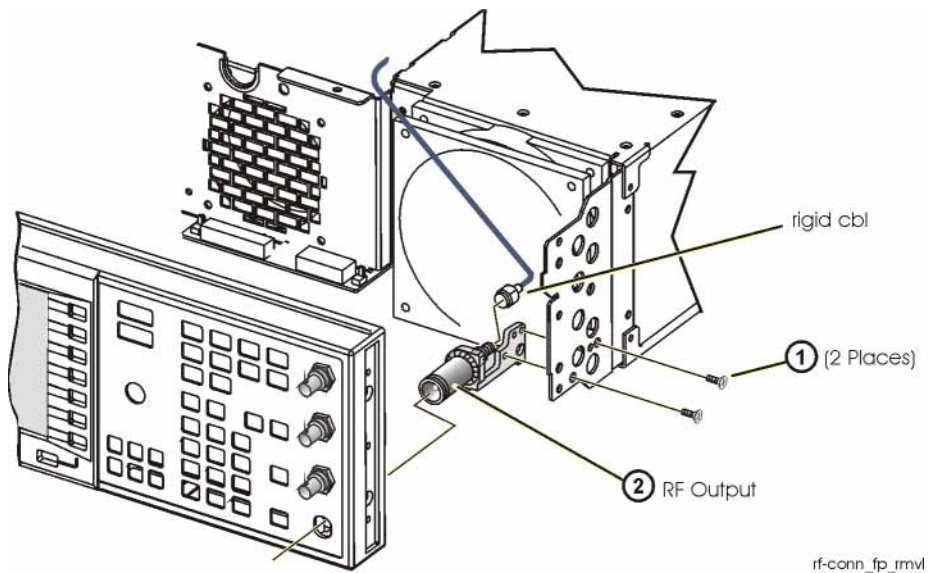
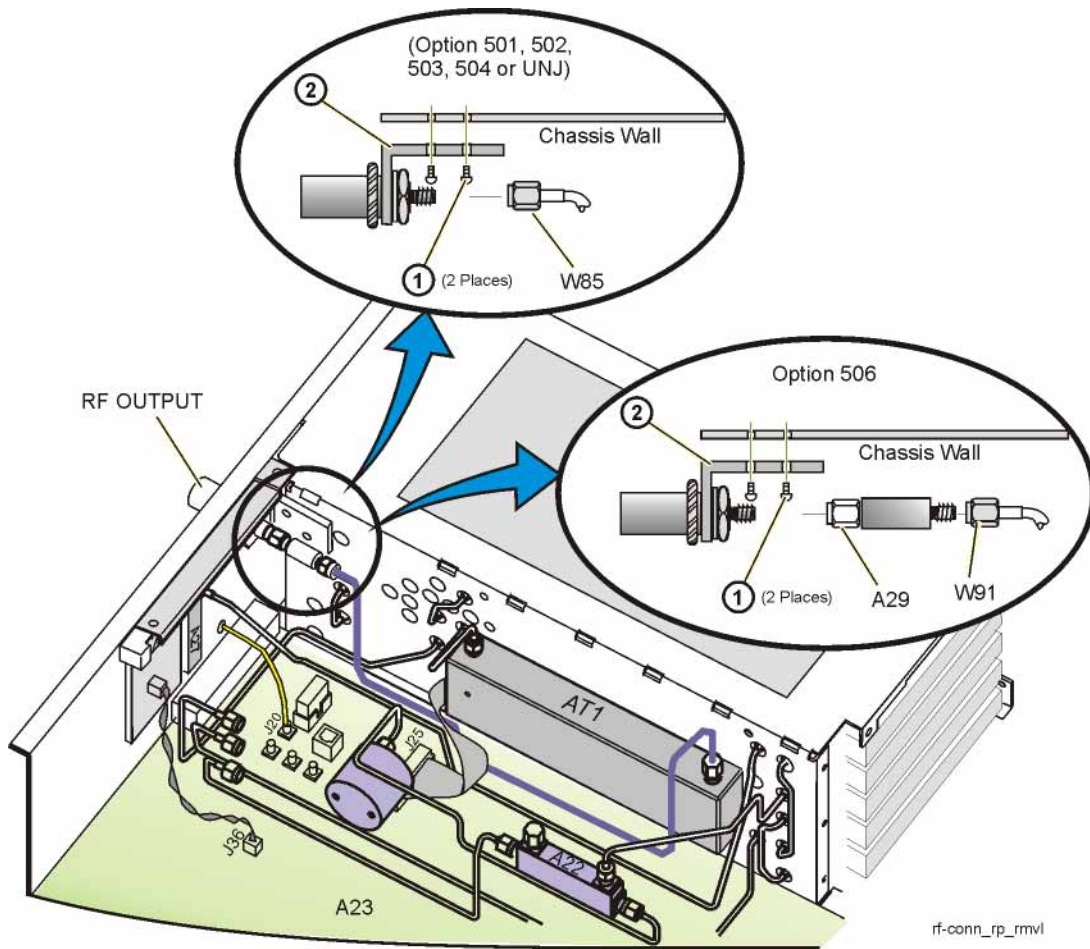

Figure 3-46 RF Output Connector for Option 1EM



4 Post-Repair Procedures

Performance Tests

The tables in this section list the performance tests that must be performed when a specific assembly is repaired or replaced. Refer to the list below for the tables that apply to your signal generator.

For E4428C signal generators, refer to [Table 4-1](#) and [Table 4-2](#).

For E4438C signal generators, refer to [Table 4-3](#) and [Table 4-4](#).

Table 4-1 E4428C — Performance Tests for Assemblies A1 through A16

Performance Tests The following performance tests are listed in the order that they should be performed to minimize changes in test equipment configurations. Self Test should be performed each time that any assembly is repaired or replaced.	Replaced Assembly										
	A1 Keyboard	A2 Display	A2DS1 Display Backlight	A3 Front Panel Auxiliary Board	A4 Inverter	A6 Power Supply	A12 CPU	A13 Output	A14 Extended Frequency Output	A15 Sampler	A16 Frac-N
Self Test	x	x	x	x	x	x	x	x	x	x	x
Internal FM Accuracy and Distortion											x
Internal AM Accuracy and Distortion								x	x		
Phase Modulation Accuracy and Distortion											x
FM Frequency Response											x
AM Frequency Response								x	x		
Phase Modulation Frequency Response											x
DCFM Frequency Offset Relative to CW											x
Harmonic, Subharmonic, and Nonharmonic Spurious Signals						x		x		x	x
Power Level Accuracy						x		x	x		x
Pulse Modulation On/Off Ratio								x	x		
Phase Noise and Residual FM (Manual Test - Option UNJ or Option 506 Only)						x		x	x	x	x

Table 4-2 E4428C — Performance Tests for Assemblies A18 through A29, B1, B2, B3, and the RF Output Connector

Performance Tests	Replaced Assembly												
	A18 Reference	A19 Daughterboard	A21 YTO Driver	A22 Coupler	A23 Motherboard	A23BT1 Battery	A24 Line Module	AT1 Electronic Attenuator or AT1 High-Power Mechanical Attenuator and A28 Reverse Power Protection	A29 DC Blocking Capacitor	B1 Power Supply Fan	B2 Small Fan	B3 Daughterboard/Card Cage Fan	RF Output Connector
The following performance tests are listed in the order that they should be performed to minimize changes in test equipment configurations.													
Self Test should be performed each time that any assembly is repaired or replaced.													
Self Test	X	X	X	X	X	X	X	X	X	X	X	X	X
Internal FM Accuracy and Distortion	X		X		X								
Internal AM Accuracy and Distortion	X				X								
Phase Modulation Accuracy and Distortion	X		X		X								
FM Frequency Response	X		X		X								
AM Frequency Response	X				X								
Phase Modulation Frequency Response	X		X		X								
DCFM Frequency Offset Relative to CW	X				X	X							
Harmonic, Subharmonic, and Nonharmonic Spurious Signals	X		X		X								
Power Level Accuracy		X	X	X	X		X	X	X				X
Timebase Aging Rate (Manual Test - Option UNJ, Option 506, or Option 1E5 Only)	X												
Pulse Modulation On/Off Ratio	X				X								
Phase Noise and Residual FM (Manual Test - Option UNJ or Option 506 Only)	X		X		X								

Table 4-3 E4438C — Performance Tests for Assemblies A1 through A16

Performance Tests The following performance tests are listed in the order that they should be performed to minimize changes in test equipment configurations. Self Test should be performed each time that any assembly is repaired or replaced.	Replaced Assembly															
	A1 Keyboard	A2 Display	A2DS1 Display Backlight	A3 Front Panel Auxiliary Board	A4 Inverter	A5 10 GB Hard Drive	A6 Power Supply	A7 Baseband Generator	A9 Digital Demodulator	A10 I/Q Multiplexer	A11 Internal Bit Error Rate Analyzer	A12 CPU	A13 Output	A14 Extended Frequency Output	A15 Sampler	A16 Frac-N
Self Test	X	X	X	X	X	X	X	X	X	X	X	X	X	X	X	X
Internal FM Accuracy and Distortion																X
Internal AM Accuracy and Distortion													X	X		
Phase Modulation Accuracy and Distortion																X
FM Frequency Response																X
AM Frequency Response													X	X		
Phase Modulation Frequency Response																X
DCFM Frequency Offset Relative to CW																X
Residual FM (not used with Option UNJ or Option 506)							X									
Harmonic, Subharmonic, and Nonharmonic Spurious Signals							X	X					X		X	X
Power Level Accuracy							X						X	X		X
Digital Modulation Level Accuracy									X				X	X		
Internal Digital Modulation Quality (Option 400, 401, or 402 Only)								X		X			X			
Custom I/Q ED Modulation Quality								X		X			X	X		
Pulse Modulation On/Off Ratio													X	X		
Burst Modulation On/Off Ratio													X	X		
CDMA Adjacent Channel Power (Not Used with Option UNB or Option 506)								X		X			X			
WCDMA Adjacent Channel Power (Option 400)								X		X			X			
Phase Noise and Residual FM (Manual Test - Option UNJ or Option 506 Only)							X						X	X	X	X
Dual Arbitrary Waveform Generator Check								X		X						
GSM Loopback BER Check (Option 300 Only)								X	X		X					

Performance Tests

Table 4-4 E4438C — Performance Tests for Assemblies A17 through A29, B1, B2, B3, and the RF Output Connector

Performance Tests	Replaced Assembly																
	A17 Synthesizer	A18 Reference	A19 Daughterboard	A20 Downconverter	A21 YTO Driver	A22 Coupler	A23 Motherboard	A23BT1 Battery	A24 Line Module	A25 Rear Panel Board	A26 Rear Panel LVDS Board (Option 1EM) and A27 Rear Panel SMB Board (Option 1EM)	AT1 Electronic Attenuator or AT1 High-Power Mechanical Attenuator and A28 Reverse Power Protection or AT1 High Power Mechanical Attenuator	A29 DC Blocking Capacitor	B1 Power Supply Fan	B2 Small Fan	B3 Daughterboard/Card Cage Fan	RF Output Connector
The following performance tests are listed in the order that they should be performed to minimize changes in test equipment configurations.																	
Self Test should be performed each time that any assembly is repaired or replaced.																	
Self Test	X	X	X	X	X	X	X	X	X	X	X	X	X	X	X	X	X
Internal FM Accuracy and Distortion	X	X			X		X										
Internal AM Accuracy and Distortion		X					X										
Phase Modulation Accuracy and Distortion	X	X			X		X										
FM Frequency Response	X	X			X		X										
AM Frequency Response		X					X										
Phase Modulation Frequency Response	X	X			X		X										
DCFM Frequency Offset Relative to CW	X	X					X	X									
Residual FM (Not Used with Option UNJ or Option 506)	X	X															
Harmonic, Subharmonic, and Nonharmonic Spurious Signals	X	X			X		X										
Power Level Accuracy	X		X		X	X	X		X	X	X	X	X				X
Timebase Aging Rate (Manual Test - Option UNJ, Option 506, or Option 1E5 Only)		X															
Internal Digital Modulation Quality (Option 400, 401, or 402 Only)							X					X					

Table 4-4 E4438C — Performance Tests for Assemblies A17 through A29, B1, B2, B3, and the RF Output Connector

Performance Tests	Replaced Assembly																
	A17 Synthesizer	A18 Reference	A19 Daughterboard	A20 Downconverter	A21 YTO Driver	A22 Coupler	A23 Motherboard	A23BT1 Battery	A24 Line Module	A25 Rear Panel Board	A26 Rear Panel LVDS Board (Option 1EM) and A27 Rear Panel SMB Board (Option 1EM)	AT1 Electronic Attenuator or AT1 High-Power Mechanical Attenuator and A28 Reverse Power Protection or AT1 High Power Mechanical Attenuator	A29 DC Blocking Capacitor	B1 Power Supply Fan	B2 Small Fan	B3 Daughterboard/Card Cage Fan	RF Output Connector
The following performance tests are listed in the order that they should be performed to minimize changes in test equipment configurations.																	
Self Test should be performed each time that any assembly is repaired or replaced.																	
Custom I/Q RF Modulation Quality							X										
Pulse Modulation On/Off Ratio		X					X										
Burst Modulation On/Off Ratio		X					X										
Phase Noise and Residual FM (Manual Test - Option UNJ or Option 506 Only)		X		X		X											
GSM Loopback BER Check (Option 300 Only)				X													

Adjustment Tests

The tables in this section list the adjustment tests that must be performed when a specific assembly is repaired or replaced. Refer to the list below for the tables that apply to your signal generator.

For E4428C signal generators, refer to [Table 4-5](#) and [Table 4-6](#).

For E4438C signal generators, refer to [Table 4-7](#) and [Table 4-8](#).

Table 4-5 E4428C — Adjustments for Assemblies A1 through A16

Adjustments The following adjustments are listed in the order that they should be performed for proper calibration. Self Test should be performed each time that any assembly is repaired or replaced.	Replaced Assembly										
	A1 Keyboard	A2 Display	A2DS1 Display Backlight	A3 Front Panel Auxiliary Board	A4 Inverter	A6 Power Supply	A12 CPU	A13 Output	A14 Extended Frequency Output	A15 Sampler	A16 Frac-N
Self Test	X	X	X	X	X	X	X	X	X	X	X
Analog Bus ADC Calibration						X	X	X	X	X	X
VCO Bias Potentiometer Calibration											X
KV versus Frequency Calibration											X
FM Scale DAC Offset Calibration											X
FM Path Offset Calibration											X
FM In-Band DAC Offset Calibration											X
FM Inverting Amplifier Offset Calibration											X
FM 1/2 Path Ratio Gain Calibration											X
Modulation Source Relative Gain Calibration											X
FM/PM Out-of-Band Calibration (Option UNJ or Option 506 Only)											X
FM/PM YO Frequency Compensation Calibration (Option UNJ or Option 506 Only)									X	X	
DCFM Calibration						X					X
AM Audio Path Offset Calibration							X	X			
Digital Gain Adjust Calibration								X			
Bypass Gain Adjust Calibration							X	X			
ALC Calibration							X	X			
Power Level Accuracy, High Power Calibration							X	X			X
ALC Modulation Driver Bias Calibration							X	X			
Power Level Accuracy, Low Power Calibration							X	X			
Power Search Calibration							X	X			
AM Gain Calibration							X	X			

Table 4-6 E4428C — Adjustments for Assemblies A17 through A29, B1, B2, B3, and the RF Output Connector

Adjustments	Replaced Assembly												
	A18 Reference	A19 Daughterboard	A21 YTO Driver	A22 Coupler	A23 Motherboard	A23BT1 Battery	A24 Line Module	AT1 Electronic Attenuator or AT1 High-Power Mechanical Attenuator and A28 Reverse Power Protection	A29 DC Blocking Capacitor	B1 Power Supply Fan	B2 Small Fan	B3 Daughterboard/Card Cage Fan	RF Output Connector
The following adjustments are listed in the order that they should be performed for proper calibration.													
Self Test should be performed each time that any assembly is repaired or replaced.													
Self Test	X	X	X	X	X	X	X	X	X	X	X	X	X
Internal Reference Oscillator Calibration	X												
Analog Bus ADC Calibration	X		X		X								
Pretune Calibration (Option UNJ or Option 506 Only)			X										
Internal Source Calibration	X				X								
Timebase DAC Calibration	X												
FM Scale DAC Offset Calibration	X		X		X								
FM Path Offset Calibration	X		X		X								
FM In-Band DAC Offset Calibration	X		X		X								
FM Inverting Amplifier Offset Calibration	X												
FM 1/2 Path Ratio Gain Calibration	X				X								
Modulation Source Relative Gain Calibration	X				X								
FM/PM Out-of-Band Calibration (Option UNJ or Option 506 Only)	X		X										
FM/PM YO Frequency Compensation Calibration (Option UNJ or Option 506 Only)	X		X										
DCFM Calibration	X					X							
External Input Peak Detector Calibration	X												
AM Audio Path Offset Calibration	X				X								

Table 4-6 E4428C — Adjustments for Assemblies A17 through A29, B1, B2, B3, and the RF Output Connector

Adjustments The following adjustments are listed in the order that they should be performed for proper calibration. Self Test should be performed each time that any assembly is repaired or replaced.	Replaced Assembly												
	A18 Reference	A19 Daughterboard	A21 YTO Driver	A22 Coupler	A23 Motherboard	A23BT1 Battery	A24 Line Module	AT1 Electronic Attenuator or AT1 High-Power Mechanical Attenuator and A28 Reverse Power Protection	A29 DC Blocking Capacitor	B1 Power Supply Fan	B2 Small Fan	B3 Daughterboard/Card Cage Fan	RF Output Connector
Bypass Gain Adjust Calibration								X					
ALC Calibration								X					
Power Level Accuracy, High Power Calibration				X				X	X				X
ALC Modulation Driver Bias Calibration								X					
Power Level Accuracy, Low Power Calibration								X					
Power Search Calibration								X					
AM Gain Calibration								X					

Table 4-7 E4438C — Adjustments for Assemblies A1 through A16

Adjustments The following adjustments are listed in the order that they should be performed for proper calibration. Self Test should be performed each time that any assembly is repaired or replaced.	Replaced Assembly															
	A1 Keyboard	A2 Display	A2DS1 Display Backlight	A3 Front Panel Auxiliary Board	A4 Inverter	A5 10 GB Hard Drive	A6 Power Supply	A7 Baseband Generator	A9 Digital Demodulator	A10 I/Q Multiplexer	A11 Internal Bit Error Rate Analyzer	A12 CPU	A13 Output	A14 Extended Frequency Output	A15 Sampler	A16 Frac-N
Self Test	X	X	X	X	X	X	X	X	X	X	X	X	X	X	X	X
Analog Bus ADC Calibration												X	X	X	X	X
VCO Bias Potentiometer Calibration																X
KV versus Frequency Calibration																X
FM Scale DAC Offset Calibration																X
FM Path Offset Calibration																X
FM In-Band DAC Offset Calibration																X
FM Inverting Amplifier Offset Calibration																X
FM 1/2 Path Ratio Gain Calibration																X
Modulation Source Relative Gain Calibration																X
FM/PM Out-of-Band Calibration (Option UNJ or Option 506 Only)																X
FM/PM YO Frequency Compensation Calibration (Option UNJ or Option 506 Only)															X	X
DCFM Calibration												X				X
AM Audio Path Offset Calibration													X	X		
Burst Modulator Calibration													X	X		
Prelevel Calibration													X	X		X
VBLO Mixer Bias Calibration													X	X		
Digital Gain Adjust Calibration													X	X		
Bypass Gain Adjust Calibration													X	X		
ALC Calibration													X	X		
Power Level Accuracy, High Power Calibration													X	X		X
ALC Modulation Driver Bias Calibration													X	X		
Power Level Accuracy, Low Power Calibration													X	X		
Power Search Calibration													X	X		
AM Gain Calibration													X	X		
I/Q Gain/Offset/Quadrature Calibration								X	X				X	X		
I/Q Impairment Calibration								X	X				X	X		
IQ Timeskew Calibration-Baseband								X								
IQ Timeskew Calibration-RF								X					X			

Table 4-8 E4438C — Adjustments for Assemblies A17 through A29, B1, B2, B3, and the RF Output Connector

Adjustments	Replaced Assembly																
	A17 Synthesizer	A18 Reference	A19 Daughterboard	A20 Downconverter	A21 YTO Driver	A22 Coupler	A23 Motherboard	A23BT1 Battery	A24 Line Module	A25 Rear Panel Board	A26 Rear Panel LVDS Board (Option IEM) and A27 Rear Panel SMB Board (Option IEM)	A21 Electronic Attenuator or AT1 High-Power Mechanical Attenuator and A28 Reverse Power Protection	A29 DC Blocking Capacitor	B1 Power Supply Fan	B2 Small Fan	B3 Daughterboard/Card Cage Fan	RF Output Connector
The following adjustments are listed in the order that they should be performed for proper calibration.																	
Self Test should be performed each time that any assembly is repaired or replaced.																	
Self Test	X	X	X	X	X	X	X	X	X	X	X	X	X	X	X	X	X
Internal Reference Oscillator Calibration		X															
Analog Bus ADC Calibration	X	X			X		X										
Pretune Calibration (Option UNJ or Option 506 Only)					X												
Internal Source Calibration		X					X										
VCO Bias Potentiometer Calibration	X																
Timebase DAC Calibration		X															
FM Scale DAC Offset Calibration	X	X			X		X										
FM Path Offset Calibration	X	X			X		X										
FM In-Band DAC Offset Calibration	X	X			X		X										
FM Inverting Amplifier Offset Calibration	X	X															
FM 1/2 Path Ratio Gain Calibration		X					X										
Modulation Source Relative Gain Calibration		X					X										
FM Out-of-Band Calibration (Not Used with Option UNJ or Option 506)	X	X															
FM/PM Out-of-Band Calibration (Option UNJ or Option 506 Only)		X			X												
FM/PM YO Frequency Compensation Calibration (Option UNJ or Option 506 Only)		X			X												
DCFM Calibration	X	X						X									

Table 4-8 E4438C — Adjustments for Assemblies A17 through A29, B1, B2, B3, and the RF Output Connector

Adjustments	Replaced Assembly																
	A17 Synthesizer	A18 Reference	A19 Daughterboard	A20 Downconverter	A21 YTO Driver	A22 Coupler	A23 Motherboard	A23BT1 Battery	A24 Line Module	A25 Rear Panel Board	A26 Rear Panel LVDS Board (Option IEM) and A27 Rear Panel SMB Board (Option IEM)	A28 Electronic Attenuator or AT1 High-Power Mechanical Attenuator and A28 Reverse Power Protection	A29 DC Blocking Capacitor	B1 Power Supply Fan	B2 Small Fan	B3 Daughterboard/Card Cage Fan	RF Output Connector
External Input Peak Detector Calibration		X															
AM Audio Path Offset Calibration		X					X										
Prelevel Calibration	X																
Bypass Gain Adjust Calibration												X					
ALC Calibration												X					
Power Level Accuracy, High Power Calibration	X					X					X	X	X				X
ALC Modulation Driver Bias Calibration												X					
Power Level Accuracy, Low Power Calibration												X					
Power Search Calibration												X					
AM Gain Calibration												X					

5 Safety and Regulatory

Safety Notes

The following safety notes are used throughout this manual. Familiarize yourself with each of the notes and its meaning before operating this instrument.

CAUTION Caution denotes a hazard. It calls attention to a procedure that, if not correctly performed or adhered to, would result in damage to or destruction of the product. Do not proceed beyond a caution sign until the indicated conditions are fully understood and met.

WARNING Warning denotes a hazard. It calls attention to a procedure which, if not correctly performed or adhered to, could result in injury or loss of life. Do not proceed beyond a warning note until the indicated conditions are fully understood and met.

General Safety Considerations

The following safety notes apply specifically to signal generators. These notes also appear in other chapters of this service guide as required.

WARNING These servicing instructions are for use by qualified personal only. To avoid electrical shock, do not perform any servicing unless you are qualified to do so.

WARNING The opening of covers or removal of parts is likely to expose dangerous voltages. Disconnect the product from all voltage sources before starting to open.

WARNING The detachable power cord is the instrument disconnecting device. It disconnects the mains circuits from the mains supply before other parts of the instrument. The front panel switch is only a standby switch and is not a LINE switch (disconnecting device).

WARNING The power cord is connected to internal capacitors that may remain live for 5 seconds after disconnecting the plug from its power supply.

WARNING This is a Safety Class 1 Product (provided with a protective earthing ground incorporated in the power cord). The mains plug shall only be inserted in a socket outlet provided with a protective earth contact. Any interruption of the protective conductor inside or outside of the product is likely to make the product dangerous. Intentional interruption is prohibited.

WARNING Danger of explosion if battery is incorrectly replaced. Replace only with the same or equivalent type recommended. Discard used batteries according to manufacturer's instructions.

CAUTION Many of the assemblies in this instrument are very susceptible to damage from ESD (electrostatic discharge). Perform service procedures only at a static-safe workstation and wear a grounding strap.

Lithium Battery Disposal

When the battery on the A14 CPU/Motherboard is exhausted and/or ready for disposal, dispose of it according to your country's requirements. You can return the battery to your nearest Agilent Technologies Sales and Service office for disposal, if required

Figure 5-1



Assistance

Product maintenance agreements and other customer assistance agreements are available for Agilent Technologies products. For any assistance, contact your nearest Agilent Technologies sales and service office.

Notice

The information contained in this document is subject to change without notice.

Agilent Technologies makes no warranty of any kind with regard to this material, including but not limited to, the implied warranties of merchantability and fitness for a particular purpose. Agilent Technologies shall not be liable for errors contained herein or for incidental or consequential damages in connection with the furnishing, performance, or use of this material.

Certification

Agilent Technologies Company certifies that this product met its published specifications at the time of shipment from the factory. Agilent Technologies further certifies that its calibration measurements are traceable to the United States National Institute of Standards and Technology, to the extent allowed by the Institute's calibration facility, and to the calibration facilities of other International Standards Organization members.

Numerics

10 GB hard drive, replacing, 3-21

A

A19 daughterboard

measuring aid, 1-3

accessories, part numbers, 2-87

adjustments, post-repair, 4-8

adjustments, troubleshooting, 1-84

Agilent Technologies, contacting, 1-113

Agilent Technologies, returning signal generator to, 1-114

aids, troubleshooting, 1-3

analog bus ADC calibration, troubleshooting, 1-87

assemblies, replaceable, 3-3

assembly level troubleshooting, 1-21

attenuator, replacing, 3-68–3-73

B

baseband generator self-tests, 1-56

baseband generator, replacing, 3-26

battery, replacing, 3-59

block descriptions, 1-115

C

cables

daughterboard, replacing, 3-50

extender, ribbon, 1-3

part numbers, 2-24–2-64

calibration, I/Q troubleshooting, 1-108

capacitor, DC blocking, replacing, 3-74

card cage, measuring aid, 1-3

connector, output, replacing, 3-82

coupler, replacing, 3-54

covers, replacing, 3-4

CPU

power-on, troubleshooting, 1-4

replacing, 3-34

self-tests, 1-50

D

daughterboard

cable, replacing, 3-50

card cage fan, replacing, 3-80

replacing, 3-48

daughterboard, measuring aid, 1-3

DC blocking capacitor, replacing, 3-74

descriptions, blocks, 1-115

digital demodulator self-tests, 1-54

digital demodulator, replacing, 3-28

display, troubleshooting, 1-8

documentation, 2-xiii

documentation, part numbers, 2-87

downconverter, replacing, 3-52

E

exchange assemblies, 2-7

extended frequency output self-tests, 1-59

extended frequency output, replacing, 3-38

F

fan, replacing, 3-78

frac-n, replacing, 3-42

front panel

cable part numbers, 2-24–2-64

display, troubleshooting, 1-8

replacing, 3-6

G

guides, 2-xiii

H

hard drive, replacing, 3-21

hardware, 2-66–2-86

high-power mechanical attenuator, replacing, 3-68

I

I/Q

calibration troubleshooting, 1-108

multiplexer self-tests, 1-28

multiplexer, replacing, 3-30

installation guide, 2-xiii

internal bit error rate analyzer self-tests, 1-52

internal bit error rate analyzer, replacing, 3-32

inverter, replacing, 3-19

K

keyboard, troubleshooting, 1-8

L

line module, replacing, 3-60

LVDS board, replacing, 3-66

M

major assemblies, 2-7

mechanical attenuator, replacing, 3-68

module, line, replacing, 3-60

motherboard self-tests, 1-62

motherboard, replacing, 3-56

O

options, hardware, [2-7](#)
output connector, replacing, [3-82](#)
output self-tests, [1-33](#), [1-64](#)
output, replacing, [3-36](#)

P

performance tests, post-repair, [4-2](#)
performance tests, troubleshooting, [1-90](#)
post-repair procedures, [4-2](#)
power supplies, troubleshooting, [1-21–1-27](#)
power supply, replacing, [3-24](#), [3-76](#)
power supply, troubleshooting, [1-4](#)
programming guide, [2-xiii](#)

R

rear panel
 board, replacing, [3-64](#)
 LVDS board, replacing, [3-66](#)
 replacing, [3-62](#)
 SMB board, replacing, [3-66](#)
reference self-tests, [1-48](#)
reference, replacing, [3-46](#)
references, [2-xiii](#)
replaceable parts, [2-1–2-88](#)
replacement assemblies, [3-1](#)
reverse power protection (A28), replacing, [3-68](#)
RF path, troubleshooting, [1-73](#)
ribbon cable extender, using, [1-3](#)

S

sampler self-tests, [1-30](#)
sampler, replacing, [3-40](#)
SCPI reference, [2-xiii](#)
self-tests, [1-17](#), [1-28–1-67](#)
semi-rigid cable-extender probe, using, [1-3](#)
service
 guide, [2-xiii](#)
signal generator, returning, [1-114](#)
SMB board, replacing, [3-66](#)
synthesizer self-tests, [1-37](#)
synthesizer, replacing, [3-44](#)

T

troubleshooting, [1-1](#)

U

unlevels, troubleshooting, [1-73](#)
unlocks, troubleshooting, [1-68](#)

user
 documentation, [2-xiii](#)

Y

YTO driver self-tests, [1-40](#)
YTO driver, replacing, [3-54](#)