

**Agilent Technologies**  
**89610A, 89611A, 89640A, and 89641A**  
**Performance Verification Tests**

January 2004

© Agilent Technologies, Inc. All rights reserved.  
1615 75th Street SW, Everett, Washington 98203-6261 U.S.A.

## **Notices**

The information contained in this document is subject to change without notice.

Agilent Technologies makes no warranty of any kind with regard to this document, including, but not limited to, the implied warranties of merchantability and fitness for a particular purpose. Agilent Technologies shall not be liable for errors contained herein or direct, indirect, special, incidental, or consequential damages in connection with the furnishing, performance, or use of the material.

Copyright © 2001-2004 Agilent Technologies, Inc.

---

# Contents

|   |           |
|---|-----------|
| <b>Before Running the Performance Tests</b> ..... | <b>5</b>  |
| <b>Installing the Test Software</b> .....         | <b>5</b>  |
| <b>Exec 3 Test Software</b> .....                 | <b>6</b>  |
| <b>Test Results</b> .....                         | <b>6</b>  |
| <b>Device Under Test Information</b> .....        | <b>7</b>  |
| <b>Test System Devices</b> .....                  | <b>8</b>  |
| <b>Test Procedures</b> .....                      | <b>9</b>  |
| <b>Calibrate Test Equipment</b> .....             | <b>10</b> |
| <b>Recommended Test Equipment</b> .....           | <b>12</b> |
| <b>Contact Information</b> .....                  | <b>17</b> |
| <b>89610A Tests</b> .....                         | <b>18</b> |
| <b>Running the Program</b> .....                  | <b>19</b> |
| <b>Test Duration</b> .....                        | <b>19</b> |
| <b>89610A Auto Calibrate</b> .....                | <b>20</b> |
| <b>89610 Residual Response</b> .....              | <b>21</b> |
| <b>89610A Noise</b> .....                         | <b>22</b> |
| <b>89610A Input VSWR</b> .....                    | <b>23</b> |
| <b>89610 Channel Match</b> .....                  | <b>24</b> |
| <b>89610 Intermodulation Distortion</b> .....     | <b>25</b> |
| <b>89610 Harmonic Distortion</b> .....            | <b>26</b> |
| <b>89610A Sideband Spurs</b> .....                | <b>27</b> |
| <b>89610A Phase Noise</b> .....                   | <b>28</b> |
| <b>89610 Amplitude Linearity</b> .....            | <b>29</b> |
| <b>89610 Frequency Accuracy</b> .....             | <b>30</b> |
| <b>89610 Amplitude Accuracy</b> .....             | <b>31</b> |
| <b>89640A Tests</b> .....                         | <b>33</b> |
| <b>Running the Program</b> .....                  | <b>34</b> |
| <b>Test Duration</b> .....                        | <b>34</b> |
| <b>89640A Auto Calibrate</b> .....                | <b>35</b> |
| <b>89640 Residual Response</b> .....              | <b>36</b> |
| <b>89640A Noise</b> .....                         | <b>37</b> |
| <b>89640A Input VSWR</b> .....                    | <b>38</b> |
| <b>89640 Channel Match</b> .....                  | <b>39</b> |
| <b>89640 Intermodulation Distortion</b> .....     | <b>40</b> |
| <b>89640 Harmonic Distortion</b> .....            | <b>41</b> |
| <b>89640A Sideband Spurs</b> .....                | <b>42</b> |
| <b>89640A Phase Noise</b> .....                   | <b>43</b> |
| <b>89640 Amplitude Linearity</b> .....            | <b>44</b> |
| <b>89640 Frequency Accuracy</b> .....             | <b>45</b> |
| <b>89640 Amplitude Accuracy</b> .....             | <b>46</b> |

**Contents**

**89611A Tests . . . . . 48**  
    **Running the Program . . . . . 49**  
    **Test Duration . . . . . 49**  
    **89611A Auto Calibrate. . . . . 50**  
    **89611 IF Residual Response . . . . . 51**  
    **89611A Input Noise . . . . . 52**  
    **89611A Input VSWR . . . . . 53**  
    **89611 Channel Match . . . . . 54**  
    **89611 Intermodulation Distortion . . . . . 55**  
    **89611 Harmonic Distortion . . . . . 56**  
    **89611A Sideband Spurs . . . . . 57**  
    **89611A Phase Noise . . . . . 58**  
    **89611 Amplitude Linearity. . . . . 59**  
    **89611 Frequency Accuracy. . . . . 60**  
    **89611 Amplitude Accuracy. . . . . 61**  
**89641A Tests . . . . . 63**  
    **Running the Program . . . . . 64**  
    **Test Duration . . . . . 64**  
    **89641A Auto Calibrate. . . . . 65**  
    **89641 Residual Response. . . . . 66**  
    **89641A Noise. . . . . 67**  
    **89641A Input VSWR . . . . . 68**  
    **89641 Channel Match . . . . . 69**  
    **89641A Intermodulation Distortion . . . . . 70**  
    **89641 Harmonic Distortion . . . . . 71**  
    **89641A Sideband Spurs . . . . . 72**  
    **89641A Phase Noise . . . . . 73**  
    **89641A Amplitude Linearity . . . . . 74**  
    **89641A Frequency Accuracy . . . . . 75**  
    **89641A Amplitude Accuracy . . . . . 76**  
**Error Messages. . . . . 78**

## Before Running the Performance Tests

Before you run the performance tests, you must do the following:

- Install the test software, page 5.
- Verify that you are running Internet Explorer version 4.0 or later.
- Verify that you have installed the Agilent 89600 VSA software version 5.00 or greater and the associate I/O libraries. If you have a previous version of the software installed, you will get an error message (see page 78) when you try to run the performance tests.
- Ensure that you have configured the VXI measurement hardware correctly in the 89600 VSA **Select Hardware** dialog box for both the Vector Signal Analyzer and the Spectrum Analyzer applications. This means that you have specified the correct modules for ADC 1, ADC 2, Tuner 1, Tuner 2, Input 1, and Input 2.
- Fill in the Device Under Test information, page 7.
- (Optional) Fill in the Exec Settings information. The information is provided for your convenience, but is not required for running the tests.
- Complete the Test System Device table, page 8.
- Calibrate test equipment as required. This may involve running one of three calibration procedures included under Test Procedures, page 10.

---

### Installing the Test Software

Run the program “89600PerformanceTestSetup.exe”. We recommend that you install the software in the default directory (C:\Program Files\Agilent\Exec).

## Before Running the Performance Tests

### Exec 3 Test Software

The Exec 3 menus are documented in a PDF file accessible from Help in the Exec 3 menu bar.

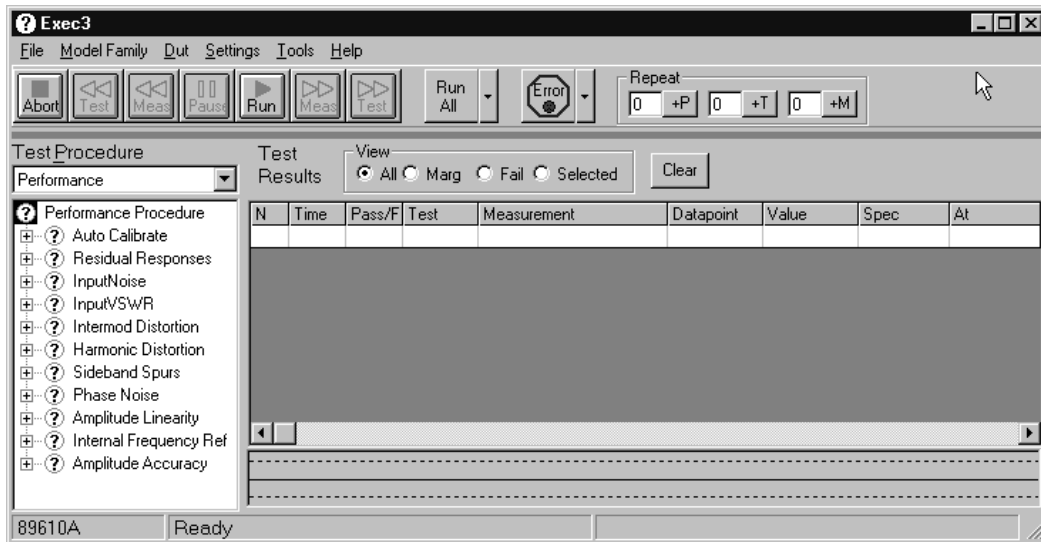

### Test Results

Test results are displayed in the right side of the window. You can recall previous tests results by clicking **File, Open Test Results** and browsing to the desired .CSV file.

The faces next to the procedure names in the left side of the window indicate pass/fail results. A green, smiling face indicates pass; a red, frowning face indicates fail.

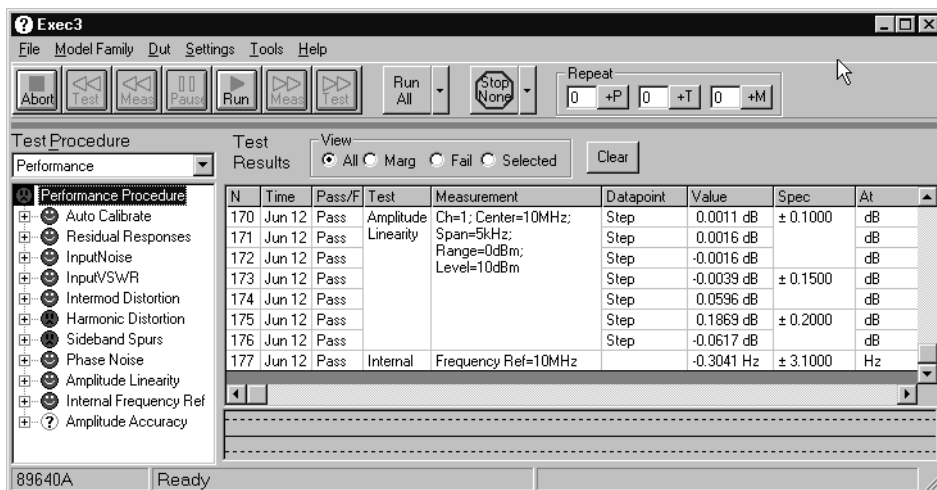

---

## Device Under Test Information

1. Click **Dut** in the menu bar and fill in the Device Under Test information.

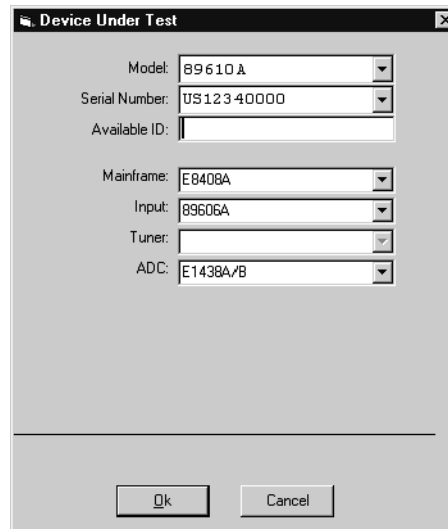

The screenshot shows a dialog box titled "Device Under Test" with the following fields and values:

| Field         | Value      |
|---------------|------------|
| Model         | 89610A     |
| Serial Number | US12340000 |
| Available ID  |            |
| Mainframe     | E8408A     |
| Input         | 89606A     |
| Tuner         |            |
| ADC           | E1438A/B   |

Buttons: Ok, Cancel

2. Select the model from a pull-down menu.
3. Enter either a serial number or Available ID to identify the specific analyzer you are testing. The Available ID can be any name or number you use to specify the analyzer.
4. Select the hardware configuration to be tested.

## Before Running the Performance Tests

### Test System Devices

For each device in your test system, specify **True** in the Present column and enter the GPIB address (if any) in the format shown in the window below. The window lists all the test equipment listed in the Recommended Test Equipment table for the model to be tested (page 12).

The screenshot shows a dialog box titled "Test System Devices". At the top, there are input fields for "Name:", "Id:", and "Cal Interval (days):". Below these is a table with the following data:

| Name     | Description          | Present | Address        | Maintenance | Manufacture  | Model  |
|----------|----------------------|---------|----------------|-------------|--------------|--------|
| HP8663A  | Signal Generator     | False   | GPIB0:19:INSTR |             | Agilent Tech | 8663A  |
| HP8753E  | Network Analyzer     | False   | GPIB0:16:INSTR |             | Agilent Tech | 8753E  |
| E4433B   | Signal Generator     | False   | GPIB0:12:INSTR |             | Agilent Tech | E4433B |
| HP11713A | Attenuator/Switch Dr | False   | GPIB0:03:INSTR |             | Agilent Tech | 11713A |
| HP5313A  | Universal Counter    | False   | GPIB0:11:INSTR |             | Agilent Tech | 5313A  |
| HPE 4419 | Power Meter          | False   | GPIB0:13:INSTR |             | Agilent Tech | E4419  |
| Sensor A | Power Sensor Ch A    | True    |                |             | Agilent Tech | 8482A  |
| Sensor B | Power Sensor Ch B    | True    |                |             | Agilent Tech | 8482A  |
| 85032B   | Calibration Kit      | True    |                |             | Agilent Tech | 85032B |
| 8494G    | 1dB Step Attenuator  | True    |                |             | Agilent Tech | 8494G  |
| 8496G    | 10dB Step Attenuator | True    |                |             | Agilent Tech | 8496G  |
| 8494H    | 1dB Step Attenuator  | False   |                |             | Agilent Tech | 8494H  |

At the bottom of the dialog box, there are two buttons: "Save" and "OK".

---

## Test Procedures

You specify which procedures to run by selecting from the Run menu.

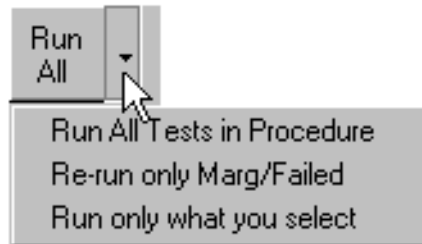

You can also specify under what circumstances the tests should stop.

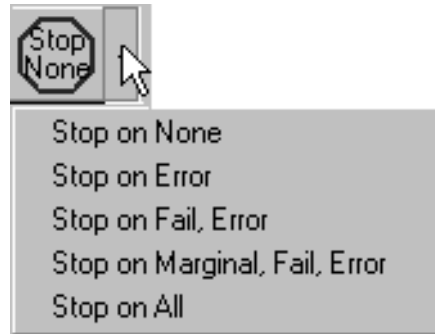

## Calibrate Test Equipment

Besides the Performance Verification tests, the software also includes two calibration procedures. To choose one of the calibration procedures, click the arrow below the Test Procedure heading and select from the menu.

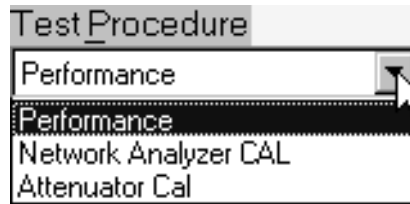

If you will be running a full set of performance verification tests, you should perform both of these calibration procedures before running the performance tests. If you will be running only individual tests, the instructions later in this chapter for each test will tell you if calibration is required before you run the test.

### Network Analyzer Cal

The following figure shows you how to setup for the network analyzer calibration. To run the test, select **Network Analyzer Cal** from the menu, then click **Run** and follow the instructions in the software.

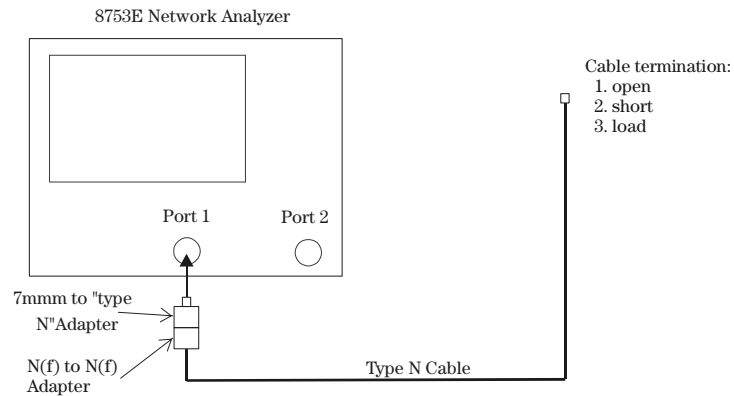

### Attenuator Cal

To run this test, select **Attenuator Cal** from the menu, then click **Run**. Follow the instructions, filling in the Attenuator Calibration Form shown below.

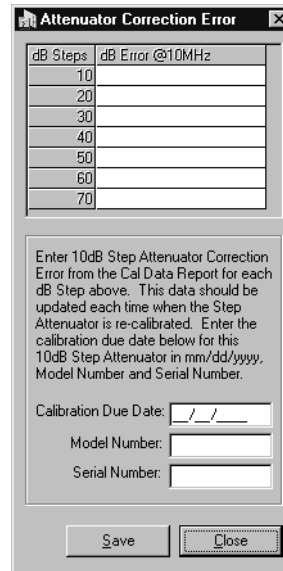

The dialog box titled "Attenuator Correction Error" contains a table with two columns: "dB Steps" and "dB Error @10MHz". The "dB Steps" column lists values from 10 to 70 in increments of 10. The "dB Error @10MHz" column contains empty input fields. Below the table is a text box with instructions: "Enter 10dB Step Attenuator Correction Error from the Cal Data Report for each dB Step above. This data should be updated each time when the Step Attenuator is re-calibrated. Enter the calibration due date below for this 10dB Step Attenuator in mm/dd/yyyy, Model Number and Serial Number." Below the text box are three input fields labeled "Calibration Due Date:", "Model Number:", and "Serial Number:". At the bottom of the dialog are "Save" and "Close" buttons.

| dB Steps | dB Error @10MHz |
|----------|-----------------|
| 10       |                 |
| 20       |                 |
| 30       |                 |
| 40       |                 |
| 50       |                 |
| 60       |                 |
| 70       |                 |

Enter 10dB Step Attenuator Correction Error from the Cal Data Report for each dB Step above. This data should be updated each time when the Step Attenuator is re-calibrated. Enter the calibration due date below for this 10dB Step Attenuator in mm/dd/yyyy, Model Number and Serial Number.

Calibration Due Date:

Model Number:

Serial Number:

## Recommended Test Equipment

| Instrument                   | Equipment Specifications<br>Input/Output Impedance: 50 $\Omega$  | Recommended Model  |
|------------------------------|--|--|
| <b>Signal Sources</b>        |  |  |
| 6 GHz Signal Generator       | Frequency: 10 MHz to 6 GHz<br>Amplitude range: -40 to +13 dBm<br>Amplitude resolution: .01 dB<br>Spurious: <-90 dBc, <40 MHz<br>Spurious: <-78 dBc, <6 GHz<br>SWR: <2.0  | 8665B  |
| Synthesized Signal Generator | Frequency: 500 kHz to 3 GHz<br>Amplitude range: -40 to +16 dBm<br>Amplitude resolution: 0.1 dB<br>Harmonic level: <-30 dBc<br>Spurious: <-90 dBc, <40 MHz<br>Spurious: <-78 dBc, <2.56 GHz<br>SWR: <1.5<br>Frequency Reference Out: 10 MHz<br>Amplitude: ~7 dBm<br>SSB Phase Noise:<br><-140 dBc/Hz at 100, 1 k, 10MHz offsets<br>RF: 1 GHz SSB Phase Noise:<br>≤-109 dBc/Hz at 20 kHz<br>≤-122 dBc/Hz at 100 kHz offset<br>External Reference Input | 8663A  |
| Digital Signal Generator     | Frequency: 500kHz to 3 GHz<br>Amplitude range: -31 dBm to +16 dBm<br>Amplitude resolution: 0.02 dB<br>Ability to generate 10 MHz Random Gaussian Noise from 500kHz to 40 MHz<br>Harmonics: ≤30 dBc, ≤7 dBm<br>Non-Harmonics: ≤-65 dBc, >1 MHz offset<br>SWR: <1.3 at 2GHz, <1.4 at 3 GHz<br>External Reference Input   | E4433B<br>Options UND, UNB<br><br>Alternates:<br>ESG-D or<br>ESG-DP series<br>(E443xB)<br>with Options UND,<br>UNB |

**Recommended Test Equipment**

|                       |   |  |
|-----------------------|---|--|
| <b>Analyzers</b>      |   |  |
| Network Analyzer      | Frequency Range: 250Hz to 6 GHz<br>Dynamic Range (varies): ≤105 dBc<br>Option 006: 6 GHz extension to the frequency range   | 8753ES<br>Option 002<br>Option 006<br><br>Alternates:<br>8753E/D<br>Option 002<br>Option 006 |
| 50 Ω Calibration Kit  | Type N for network Analyzer<br>Option 001: Deletes the four 7 mm to Type N adapters   | 85032B Option 001  |
| <b>Counters</b>       |   |  |
| Universal Counter     | Frequency: 10 MHz<br>Gate time: 10 seconds  | 53132A<br><br>Alternate:<br>53131A   |
| <b>Meters</b>         |   |  |
| Power Meter           | Dual Channel<br>Absolute Accuracy: ±0.5%<br>Power Reference Accuracy: ±0.9%   | E4419B<br><br>Alternate:<br>E4419A   |
| Power Sensor<br>(2)   | Frequency Range: 10 MHz to 6 GHz<br>Amplitude Range: -30 to +20 dBm<br>SWR (varies): ≤1.1 10 MHz to 2 GHz<br>≤1.15 2GHz to 6 GHz                                  | E9301A   |
| <b>Standards</b>      |   |  |
| Frequency Standard    | Frequency: 10 MHz<br>Accuracy: <±1x10 <sup>-10</sup><br>Including initial accuracy, drift, and environmental for 30 days.   | 5071A  |
| <b>Attenuators</b>    |   |  |
| 1 dB Step Attenuator  | Frequency Range: DC to 3 GHz<br>Range: 0 to 11 dB<br>Accuracy: Characterized by standards lab to ±0.01 dB<br>Calibrated at 10 MHz<br>SWR: ≤1.2                    | 8494G<br>Option 001<br><br>Alternate:<br>8494H   |
| 10 dB Step Attenuator | Frequency Range: DC to 4 GHz<br>Range 0 to 110 dB<br>Accuracy: Characterized by standards lab to: ±0.005 + 0.0052/10 dB step<br>Calibrated at 10 MHz<br>SWR: ≤1.2 | 8496G<br>Option 001<br><br>Alternates:<br>8496H<br>8495G/H                                   |
| Attenuator Driver     | Compatible with the 8496G/H and 8494G/H step attenuators  | 11713A   |

### Recommended Test Equipment

|                              |   |   |
|------------------------------|---|---|
| Attenuator Interconnect Kit  | Type N<br>For the 8496G and 8494G step attenuators  | 11716A  |
| Fixed Attenuators<br>Type N  | SWR: $\leq 1.2$ , $\leq 6$ GHz<br>Type N(m,f)<br>Option Attenuation<br>006 6 dB<br>020 20 dB  | 8491A<br>Options 006, 020   |
| <b>Terminations</b>          |   |   |
| 50 $\Omega$ Termination (2)  | Frequency: DC to 40 MHz<br>SWR: $\leq 1.04$ , $\leq 40$ MHz<br>BNC(m)   | Mini-Circuits <sup>a</sup><br>BTRM-50<br><br>Alternate:<br>11048C |
| 50 $\Omega$ Termination (2)  | Frequency: DC to 6 GHz<br>Type N(m)   | 909A Option 012   |
| <b>Miscellaneous Devices</b> |   |   |
| Power splitter               | Frequency: DC to 6 GHz<br>Insertion Loss: 6 to 7 dB, $\leq 3$ GHz<br>SWR: $\leq 1.1$ 10 MHz to 2 GHz<br>$\leq 1.3$ 2 GHz to 3 GHz   | 11667A  |
| Directional Bridge           | Frequency Range: 500 kHz to 6 GHz<br>Directivity: 30 dB, $\leq 5$ MHz<br>40 dB, 5 MHz to 2 GHz<br>VSWR: $\leq 1.15$ , $\leq 2$ GHz<br>Coupling: 16 dB, $< 2$ GHz (nominal)<br>Type N(f) | 86205A<br><br>Alternate:<br>86207A (to 3 GHz)                     |
| <b>Cables</b>                |   |   |
| Type N<br>(3)                | Precision Type N(m), 62 cm (24 in)  | 11500C  |
| BNC – 4ft                    | 50 $\Omega$ Coax BNC(m) Cable<br>122 cm (48 in)   | 8120-1840<br><br>Alternate:<br>10503A                             |
| BNC – 1ft<br>(2)             | 50 $\Omega$ Coax BNC(m) Cable<br>30 cm (12 in)  | 8120-1838   |

**Recommended Test Equipment**

| <b>Filters</b>             | Impedance 50 Ω   |  |
|----------------------------|--|--|
| 14 MHz LPF                 | Pass: 13.3 MHz<br>Rejection: >60 dB, > 23.8 MHz<br>SMA(f)            | TTE <sup>b</sup> # J77-14M-50-65A<br><br>Alternate:<br>Allen Avionics <sup>c</sup><br>#F2146   |
| 27.8 MHz LPF               | Pass: 16.9, 17.7, 19.9 MHz<br>Rejection: >50 dB, >33 MHz<br>SMA(f)   | 0955-1007<br><br>Alternates:<br>Allen Avionics <sup>c</sup><br>#F2146<br>RLC <sup>d</sup> # L-2583A<br>RLC <sup>d</sup> # L-2075A<br>TTE <sup>b</sup> # J77-20M-50-65A |
| 50 MHz LPF                 | Pass: 39.9 MHz<br>Rejection: >55 dB, >72 MHz<br><br>BNC(m) to BNC(f) | 0955-0306<br><br>Alternate:<br>Allen Avionics <sup>c</sup><br>#F3381   |
| 117 MHz LPF                | Pass: 67.9, 85.9 MHz<br>Rejection: >50 dB, >130 MHz                  | Allen Avionics <sup>c</sup><br>#F3713  |
| 1.0 GHz LPF                | Pass: 982.9 to 1018.2 MHz<br>Rejections: >50 dB, >1.8 GHz<br>SMA(f)  | 0955-0487<br><br>Alternates:<br>TTE <sup>b</sup> # LC9-1200M-50-2A<br>RLC <sup>d</sup> # F-10-1000   |
| <b>Adapters</b>            |  |  |
| N(m) to N(m)               |  | 1250-1475  |
| N(f) to N(f)               |  | 1250-1472  |
| Type N(m) to BNC(f)        |  | 1250-0082  |
| APC-7 to Type N(m)         | 7 mm to Type N   | 11525A   |
| Type N(m) to BNC(f)<br>(3) |  | 1250-1476  |
| Type N(f) to BNC(m)<br>(2) |  | 1250-1477  |

### Recommended Test Equipment

| <b>Controller</b>        |  |   |
|--------------------------|--|---|
| Computer                 | IBM compatible PC<br>300 MHz Pentium or AMD-K6 CPU<br>MS Windows NT 4.0 (Service Pack 5 or greater required), or Windows 2000<br>At least 192 MB RAM (256 MB recommended)<br>4 MB video RAM (8 MB recommended)<br>Hard Drive with 200 MB available space<br>CD-ROM drive<br>3.5 inch floppy disk<br>800x600 Minimum monitor resolution |   |
| <b>Accessories</b>       |  |   |
| IEEE 488 Interface Card  | High-performance GP-IB with:<br>Agilent-VISA 1.2 <sup>e</sup> or greater or<br>NI-VISA 1.2 <sup>f</sup> or greater   | 82341D<br><br>Alternate:<br>National P/N AT-<br>GPIB/TNT  |
| IEEE 1394 Interface Card | Compliant with IEEE 2394-1995, P1394a and<br>OHCI 1.0 standards  | SIIG 1394 FireWire,<br>Model # NN-<br>PCM012<br><br>VST Technologies<br>FireWire CardBus<br>Card, Model #<br>FWCBC<br><br>Evergreen<br>Technologies<br>fireLINE<br><br>CardBus/PCMCIA<br>Card |
| Software                 | Performance Verification for the 89610A,<br>89640A   |   |

- a. Mini-Circuits
- b. TTE Filters
- c. Allen Avionic, Inc.
- d. RLC Electronics
- e. Agilent-VISA
- f. National Instruments NI-VISA

---

**Contact Information**

| Item                                     | Contact   |
|--|---|
| <b>a</b> Mini-Circuits                   | Mini-Circuits, <a href="http://www.minicircuits.com">http://www.minicircuits.com</a><br>US Contact: P.O. Box 7128 Brauson, MO (800) 654-7949<br>FAX (417) 335-5945                    |
| <b>b</b> TTE Filters                     | TTE Inc., <a href="http://www.tte.com">http://www.tte.com</a><br>US Contact: 11652 W Olympic Blvd, Los Angeles, CA 90064-0142 U.S.A.<br>(310) 478-8224 FAX (310) 445-2791             |
| <b>c</b> Allen Avionics Filters          | Allen Avionic, Inc., <a href="http://www.allenavionics.com">http://www.allenavionics.com</a><br>US Contact: 224 East Second St. Mineola, N.Y. 11501 (516) 248-8080 FAX (516) 747-6724 |
| <b>d</b> RLC Electronics, Inc.           | RLC Electronics, Inc., <a href="http://www.rlcelectronics.com">http://www.rlcelectronics.com</a><br>83 Radio Circle, MT. Kisco, New York 10549 (914) 1334 FAX (914) 241-1753          |
| <b>e</b> Agilent-VISA                    | <a href="http://www.agilent.com">http://www.agilent.com</a>   |
| <b>f</b> National Instruments<br>NI-VISA | <a href="http://www.natinst.com/gpib/gpib_dl.htm">http://www.natinst.com/gpib/gpib_dl.htm</a>   |

---

## 89610A Tests

---

**Note**

The input module shown in all test setups is the 89606A. The 89606B shown here has an Ext Ref In connector (1) at the bottom of the module, and the three Ext Ref Out connectors (2) are moved up on the module front panel.

---

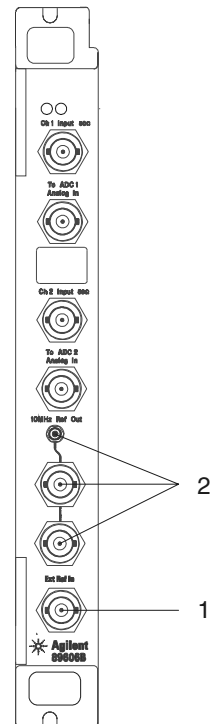

---

## Running the Program

Click **Start, Program Files, Agilent 89600 VSA, Performance Tests.**

Perform the activities under Before Running the Procedures (page 5).

Click the **Run** button.

Connect test equipment as instructed, referring to the figures on the following pages.

The 89610A performance test includes the following procedures:

- Auto Calibrate
- Residual Response
- Noise
- Input VSWR
- Channel Match (for 2-channel analyzers only)
- Intermodulation Distortion
- Harmonic Distortion
- Sideband Spurs
- Phase Noise
- Amplitude Linearity
- Frequency Accuracy
- Amplitude Accuracy

---

## Test Duration

The 89610A procedures require approximately 1.5 hours.

**89610A Auto Calibrate**

No test equipment is required for this procedure.

## 89610 Residual Response

This test verifies that the 89610A dynamic range specification for residual responses. A  $50\Omega$  load is connected to the each input channel and a full-span measurement is done with a narrow resolution bandwidth.

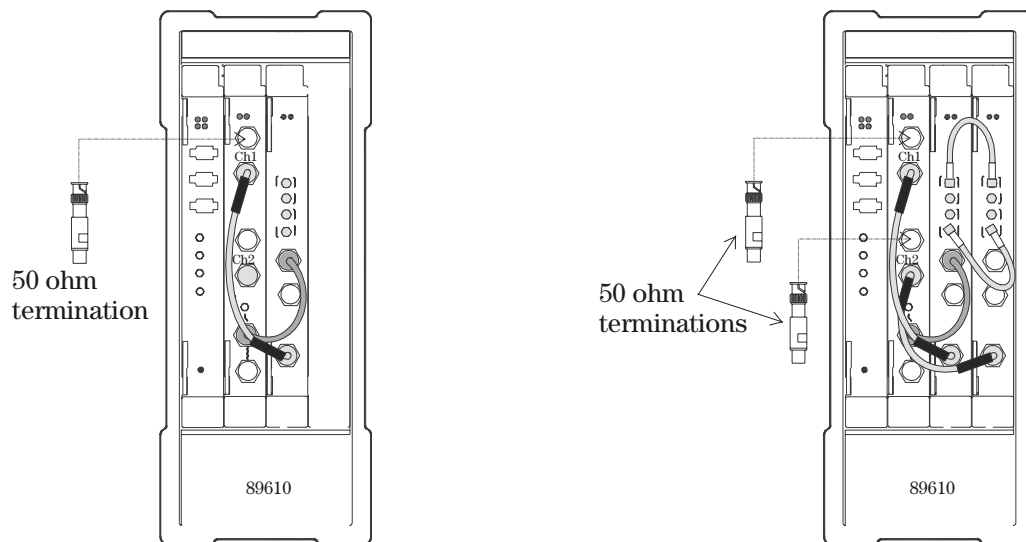

Figure 1

Test setup: 89610A Residual Response

## 89610A Noise

This test verifies that the 89610A meets the dynamic range specification for input noise density and sensitivity. Noise is measured in dBfs/Hz, or power relative to full scale per Hz of bandwidth. Noise is specified as sensitivity, dBm/Hz, on the most sensitive range.

The noise measurements are made using a wide span and power spectrum density trace. Measurements are made on several low range settings and frequency offsets. Three marker readings are taken and the middle value recorded as the noise level, to assure a noise measurement is being done instead of a spurious response measurement.

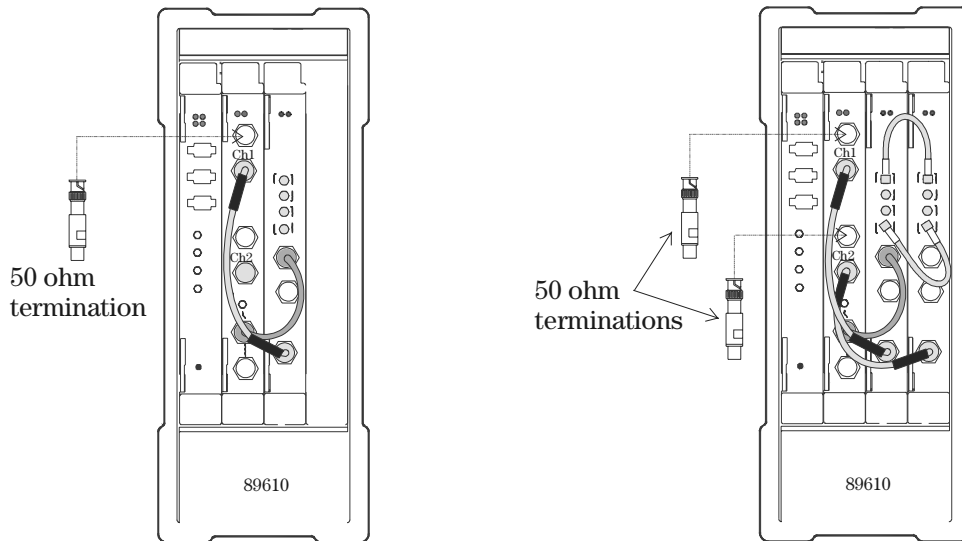

Figure 2

Test setup: 89610A Noise

## 89610A Input VSWR

This test measures the return loss of the 89610A on ranges -28 dBm and -31 dBm. A vector network analyzer is configured and calibrated to perform a one port S11 measurement.

Formula for computing VSWR from return loss:

$$\rho = 10^{\text{Return Loss}/-20}$$

$$\text{VSWR} = (1+\rho)/(1-\rho)$$

Before the input VSWR test is performed, the network analyzer must be calibrated using the Network Analyzer Cal procedure (page 10).

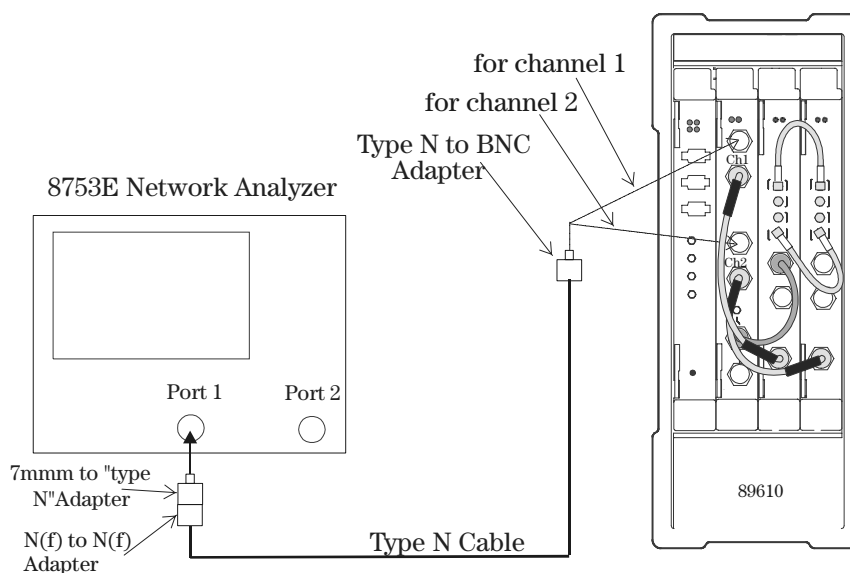

Figure 3

Test setup: 89610A Input VSWR

## 89610 Channel Match

This test measures the amplitude match between the channels of a 2-channel 89610A system. A Gaussian noise signal is applied to both channels through a power splitter. A frequency response measurement is made and saved. The splitter ports are swapped and the measurement repeated. A splitter calibration trace is calculated from these two measurements. A frequency response measurement is then made with the splitter calibration trace applied to the measurement.

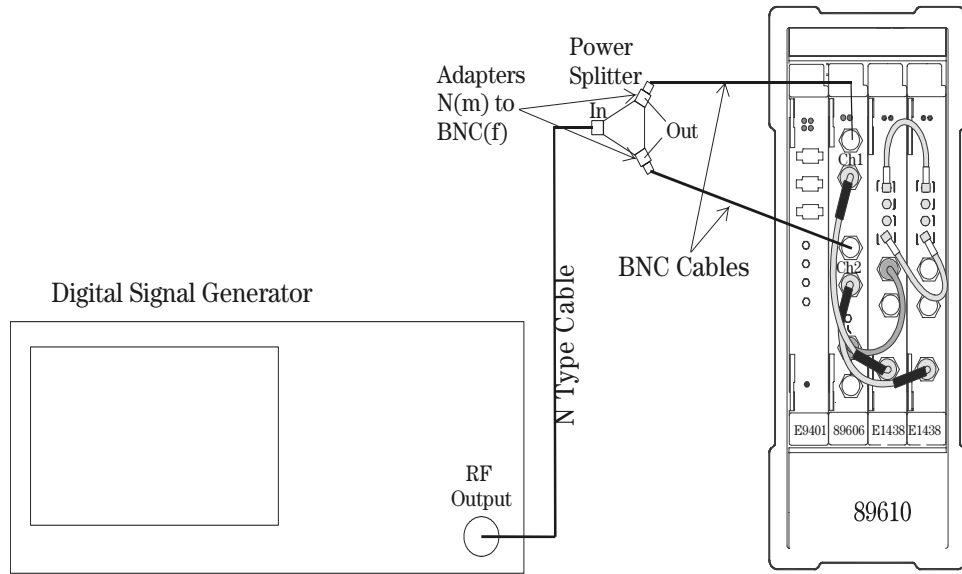

Figure 4

Test setup: 89610A Channel Match

## 89610 Intermodulation Distortion

This test measures the 2nd and 3rd order Intermodulation distortion of the analyzer with a 0.8 MHz tone separation. This separation is used so the products are in-band. A low range setting of -31 dBm is used to avoid requiring a high output from the sources.

Two signals are combined using a directional bridge and applied to the analyzer's input. A filter is used on one of the sources to reduce the 2nd order distortion product from Source 1. The sources are set for -6.5 dB full-scale on the analyzer. The analyzer then measures the amplitude of the distortion products relative to Source 1.

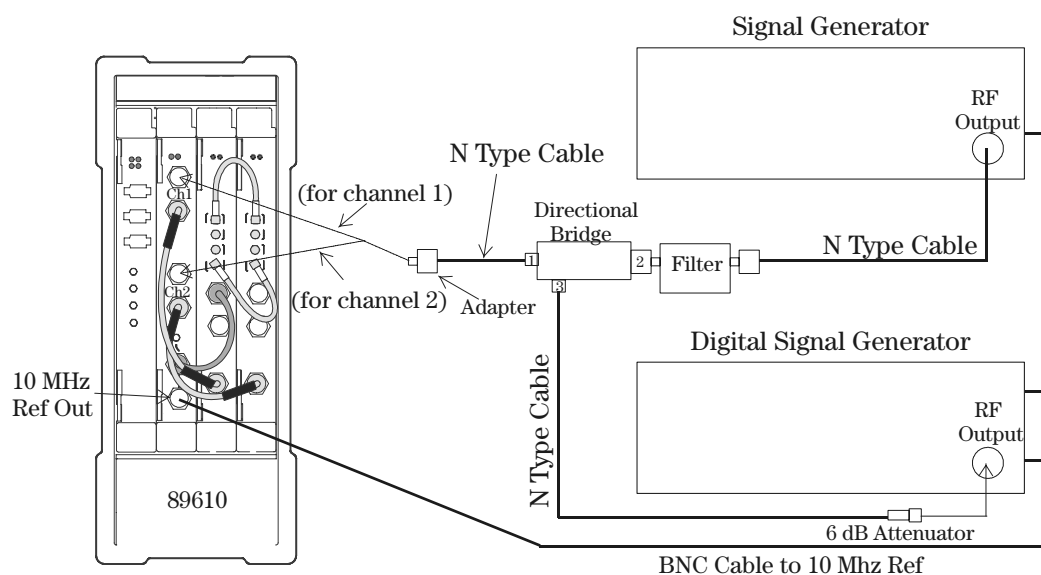

Figure 5

Test setup: 89610A Intermodulation Distortion

## 89610A Harmonic Distortion

This test verifies that the 89610A meets its dynamic range specification for harmonic distortion. In this test, a low pass filter attenuates the harmonics of the a signal from the synthesizer. The analyzer measures the source signal and adjusts the synthesizer level for -10 dBfs. The analyzer then measures the second and third harmonics. If the harmonics are out-of-band the alias of the harmonic is measured.

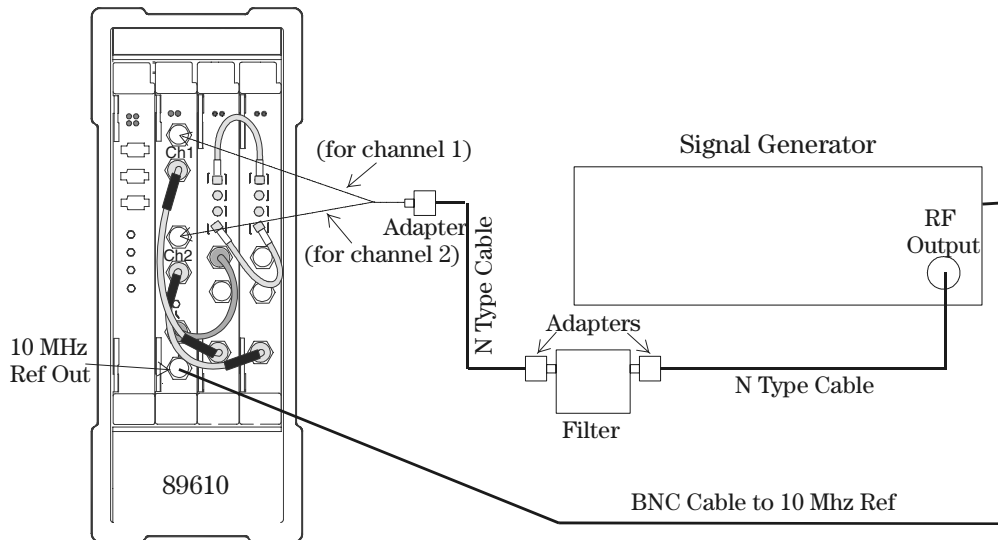

Figure 6

Test setup: 89610A Harmonic Distortion

## 89610A Sideband Spurs

This test verifies that the 89610A meets its dynamic range specification for sideband spurs (non-harmonic) signals. In this test, a signal generator supplies a clean signal to the analyzer. The analyzer measures the sideband spurs relative to the input signal.

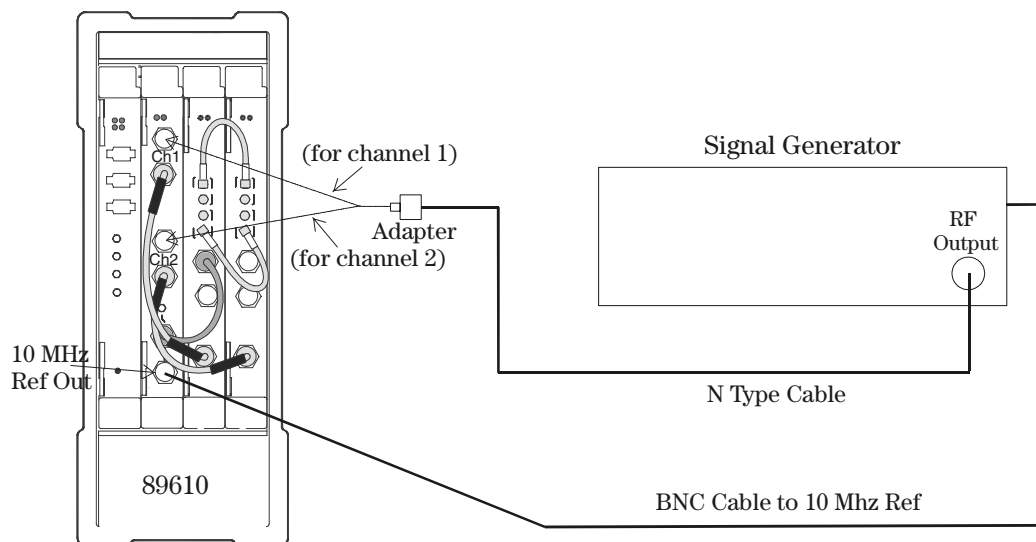

Figure 7

Test setup: 89610A Sideband Spurs

## 89610A Phase Noise

This test verifies the phase noise specifications of the 89610A. Phase noise is a measure of the frequency jitter or frequency instability of a narrow frequency measurement. Phase noise is measured in dB of power relative to carrier power, per Hz of bandwidth (dBc/Hz). A signal generator supplies a clean low phase noise signal to the analyzer.

The 89610A C/No band power marker is used to convert the dBm level to noise by calculating the noise bandwidth. The noise bandwidth is the frequency resolution, adjusted for the effects of the FFT window.

Before the Phase Noise test is performed, the step attenuator calibration factors must be entered using the Attenuator Cal procedure (page 11).

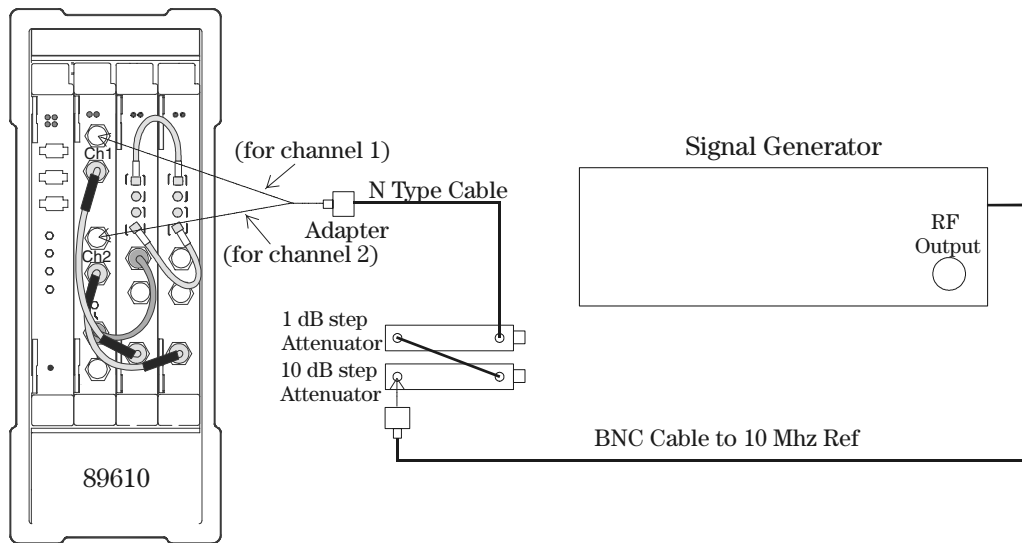

Figure 8

Test setup: 89610A Phase Noise

## 89610 Amplitude Linearity

This test verifies that the HP 89610A meets its amplitude accuracy specification for amplitude linearity. The test sets the 89610A's range to -1 dBm. A source is set for full scale input through the external attenuators. The signal is then measured. The value measured is recorded as the reference level. The attenuators are then stepped down and measurements made relative to the full-scale signal.

Averaging is used for all measurements to improve repeatability and reduce measurement uncertainty.

If the power sensor cal factors are not stored in the sensor then the operator must manually center the data into the power meter.

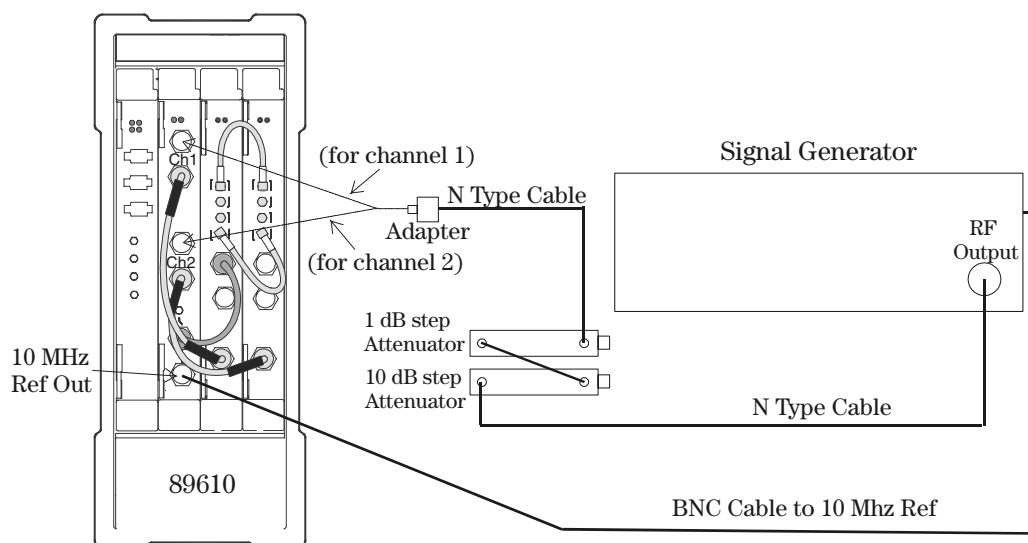

Figure 9

Test setup: 89610A Amplitude Linearity

## 89610 Frequency Accuracy

The purpose of this test is to determine in a reasonable amount of time, that the frequency reference is functional; to provide a measured frequency value, and to suggest that an adjustment be made if the yearly allowable frequency offset value is exceeded.

With the instrument set to internal reference mode, and following a minimum warm-up time of 24 hours, the frequency of the signal analyzer's frequency reference is measured using a counter locked to a frequency standard. The measured value is compared to the allowable offset guideline, and is also printed on the performance test print out.

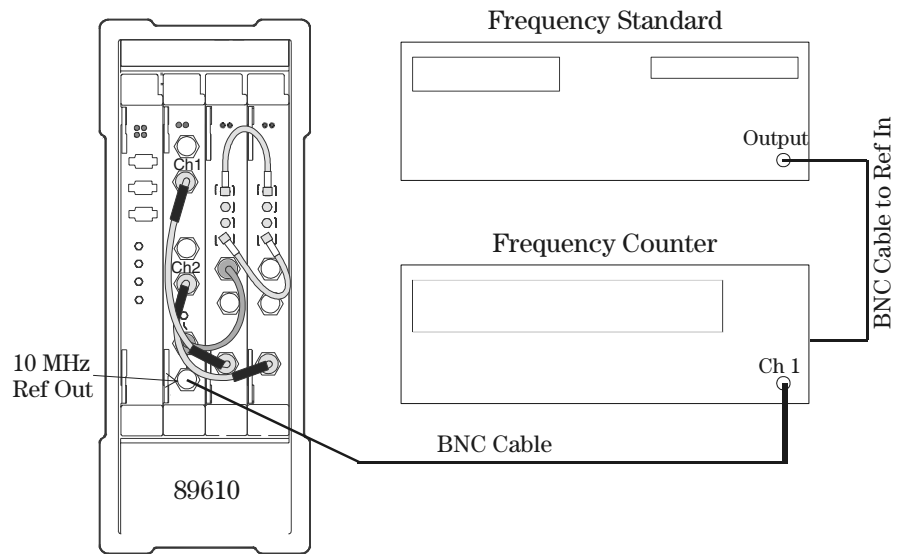

Figure 10

Test setup: 89610A Frequency Accuracy

## 89610A Amplitude Accuracy

This test verifies that the 89610A meets its amplitude accuracy specification for absolute full-scale accuracy. In this test, a signal generator outputs a signal to the power splitter. A power meter measures one output of the power splitter. The analyzer measures the other output. The two measurements are then compared. The analyzer is tested on several different ranges and frequency settings from 10 MHz to 40 MHz with the source signal at the center frequency.

To improved amplitude accuracy, the power splitter is characterized using a power sensor (the “reference” sensor) connected to one power splitter output port. The other power splitter output port connects to the “buried” sensor; it is not removed from the power splitter. Once the characterization is done, the reference sensor is removed and replaced by the analyzer.

If the power sensor cal factors are not stored in the sensor then the operator must manually center the data into the power meter.

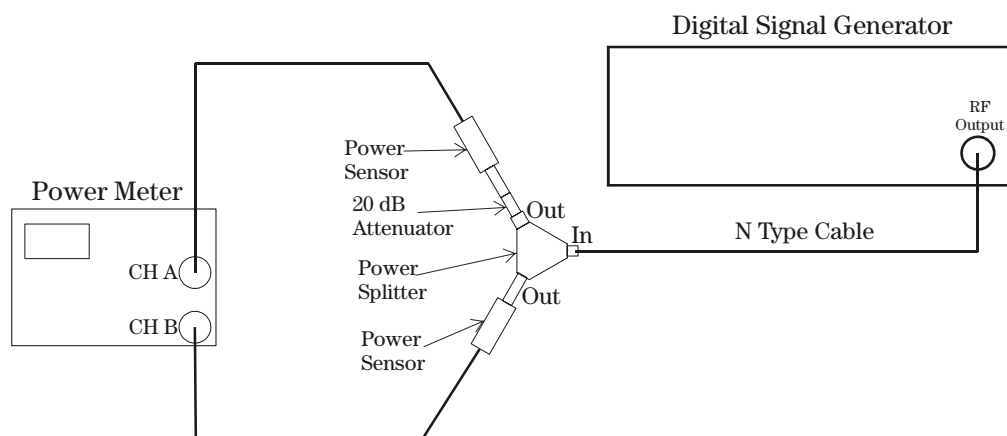

Note: For step 2, remove the 20 dB attenuator between the power splitter and the Power Meter CH A..

Figure 11

Test setup: Characterize the power splitter

## 89610A Tests

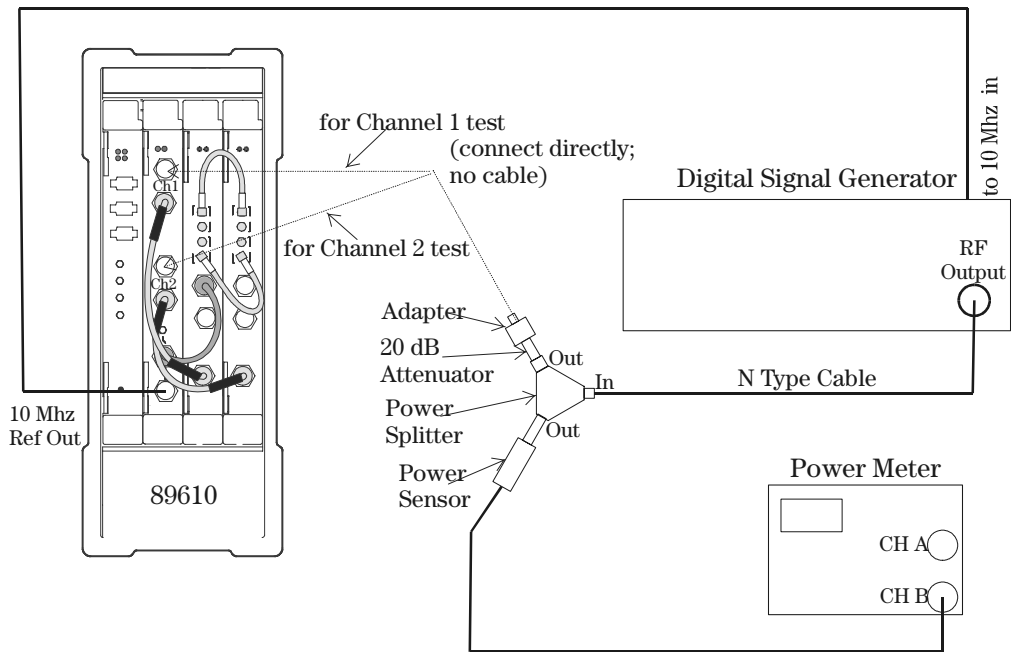

Note: For step 4, remove the 20 dB attenuator between the power splitter and the 89610 input channels.

Figure 12

Test setup: 89610A Amplitude Accuracy

---

## 89640A Tests

---

**Note**

The input module shown in all test setups is the 89605A. The 89605B shown here has an Ext Ref In connector (1) at the bottom of the module, and the three Ext Ref Out connectors (2) are moved up on the module front panel.

---

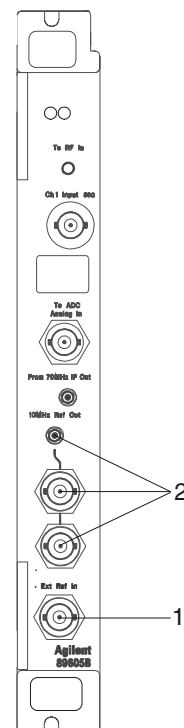

## Running the Program

Click **Start, Program Files, Agilent 89600 VSA, Performance Tests**.

Perform the activities under Before Running the Procedures (page 5).

Click the **Run** button.

Connect test equipment as instructed, referring to the figures on the following pages.

---

### Note

The figures for most of the tests show connections for a 2-channel analyzer. For a 1-channel analyzer, just connect the equipment as shown for channel 1 of the 2-channel analyzer.

The 89640A performance test includes the following procedures:

- Auto Calibrate
- Residual Response
- Noise
- Input VSWR
- Channel Match (for 2-channel analyzers only)
- Intermodulation Distortion
- Harmonic Distortion
- Sideband Spurs
- Phase Noise
- Amplitude Linearity
- Frequency Accuracy
- Amplitude Accuracy

---

## Test Duration

The 89640A procedures require approximately 2 hours.

---

## 89640A Auto Calibrate

No test equipment is required for this procedure.

---

## 89640 Residual Response

This test verifies the 89640A dynamic range specification for residual responses. A 50Ω load is connected to the each input channel and a full-span measurement is done with a narrow resolution bandwidth.

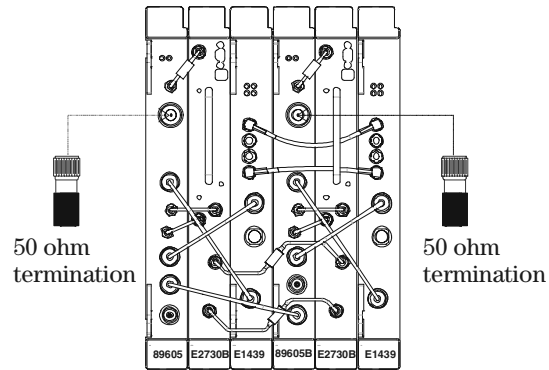

Figure 13

Test setup: 89640A 2-Channel Residual Response

## 89640A Noise

This test verifies that the 89640A meets the dynamic range specification for input noise density and sensitivity. Noise is measured in dBfs/Hz, or power relative to full scale per Hz of bandwidth. Noise is specified as sensitivity, dBm/Hz, on the most sensitive range.

The noise measurements are made using a wide span and power spectrum density trace. Measurements are made on several low range settings and frequency offsets. Three marker readings are taken and the middle value recorded as the noise level, to assure a noise measurement is being done instead of a spurious response measurement.

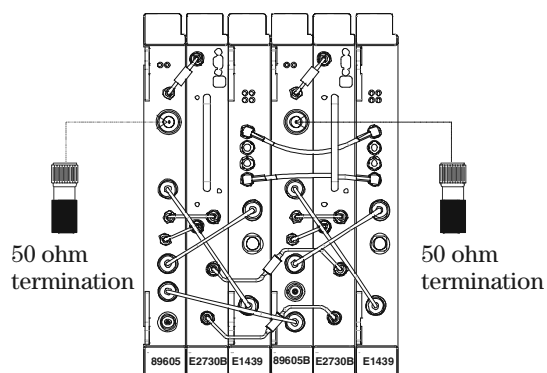

Figure 14

Test setup: 89640A 2-Channel Noise

## 89640A Input VSWR

This test measures the return loss of the 89640A on ranges -10, -20, and -30 dBm. A vector network analyzer is configured and calibrated to perform a one port S11 measurement.

Formula for computing VSWR from return loss:

$$\rho = 10^{\text{Return Loss}/-20}$$

$$\text{VSWR} = (1+\rho)/(1-\rho)$$

Before the input VSWR test is performed, the network analyzer must be calibrated using the Network Analyzer Cal procedure (page 10).

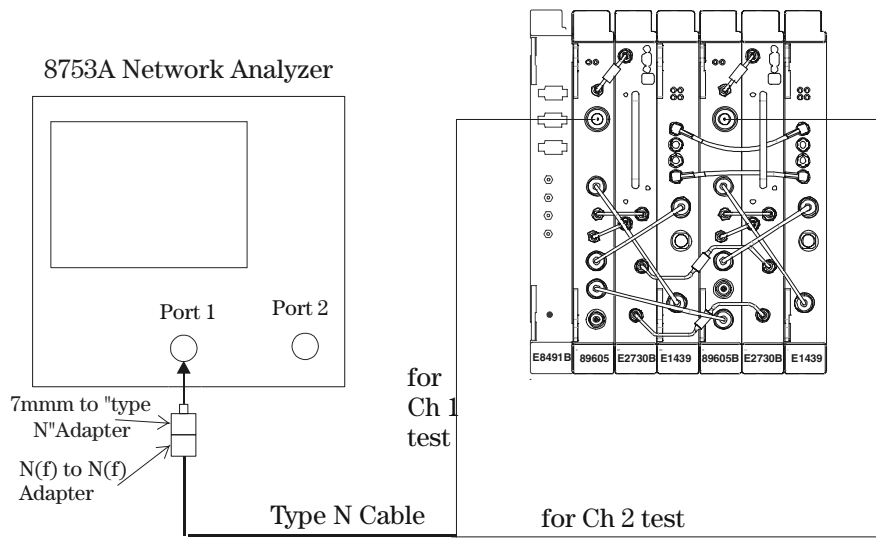

Figure 15

Figure 16

Test setup: 2-channel 89640A Input VSWR

## 89640 Channel Match

This test measures the amplitude match between the channels of a 2-channel 89610A system. A Gaussian noise signal is applied to both channels through a power splitter. A frequency response measurement is made and saved. The splitter ports are swapped and the measurement repeated. A splitter calibration trace is calculated from these two measurements. A frequency response measurement is then made with the splitter calibration trace applied to the measurement.

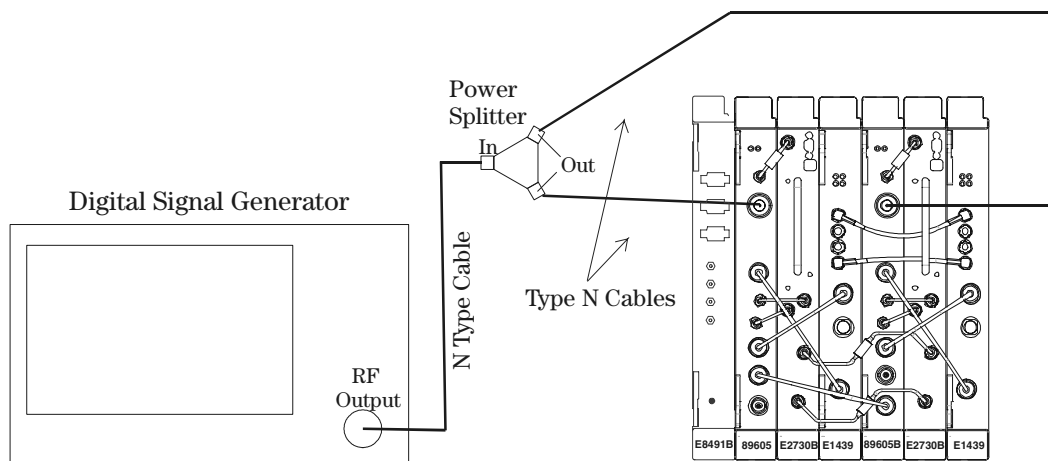

Figure 17

Test setup: 89610A Channel Match

## 89640 Intermodulation Distortion

This test measures the 2nd and 3rd order Intermodulation distortion of the analyzer with a 0.8 MHz tone separation for the base band measurements. This separation is used so the products of the input signals are in-band. A 1.1 MHz separation of the tones is used for the RF Band. A low range setting of -30 dBm is used to avoid requiring a high output from the sources.

Two signals are combined using a directional bridge and applied to the analyzer's input. A filter is used on one of the sources to reduce the 2nd order distortion product from Source 1. The sources are set for -6.5 dB full-scale on the analyzer. The analyzer then measures the amplitude of the distortion products relative to Source 1.

Figure 18

Test setup: 2-channel 89640A Intermodulation Distortion

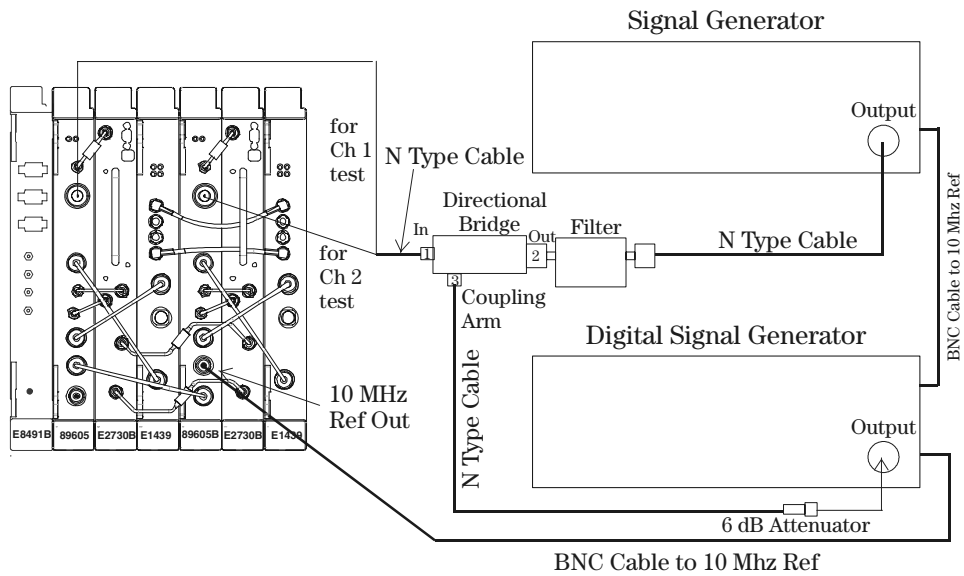

Figure 19

Test setup: 2-channel 89640A Intermodulation Distortion

## 89640 Harmonic Distortion

This test verifies that the 89640A meets its dynamic range specification for harmonic distortion. In this test, a low pass filter attenuates the harmonics of the signal from the synthesizer. The analyzer measures the source signal and adjusts the synthesizer level for -0.5 dBfs. The analyzer then measures the second and third harmonics. If the harmonics are out-of-band the alias of the harmonic is measured.

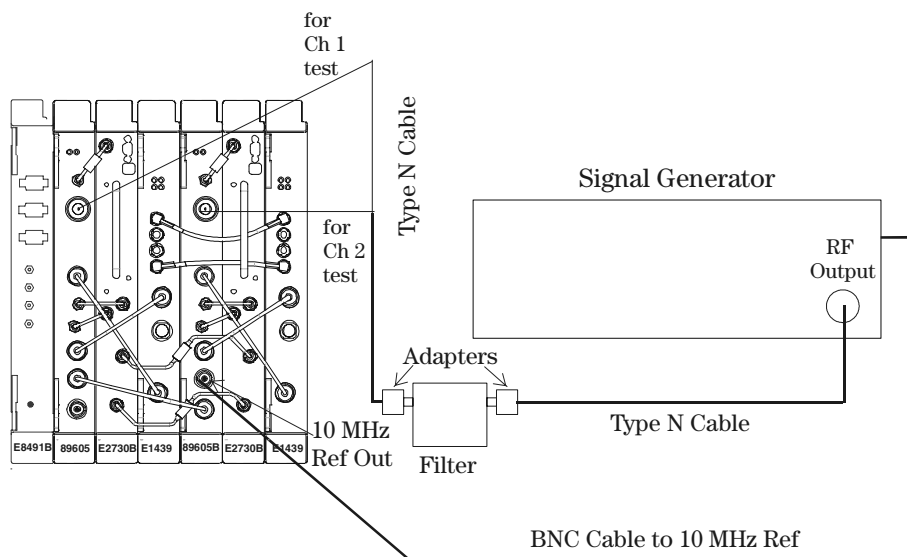

Figure 20

Test setup: 89640A Harmonic Distortion

### 89640A Sideband Spurs

This test verifies that the 89640A meets its dynamic range specification for sideband spurs (non-harmonic) signals. In this test, a signal generator supplies a clean signal to the analyzer. The analyzer measures the sideband spurs relative to the input signal.

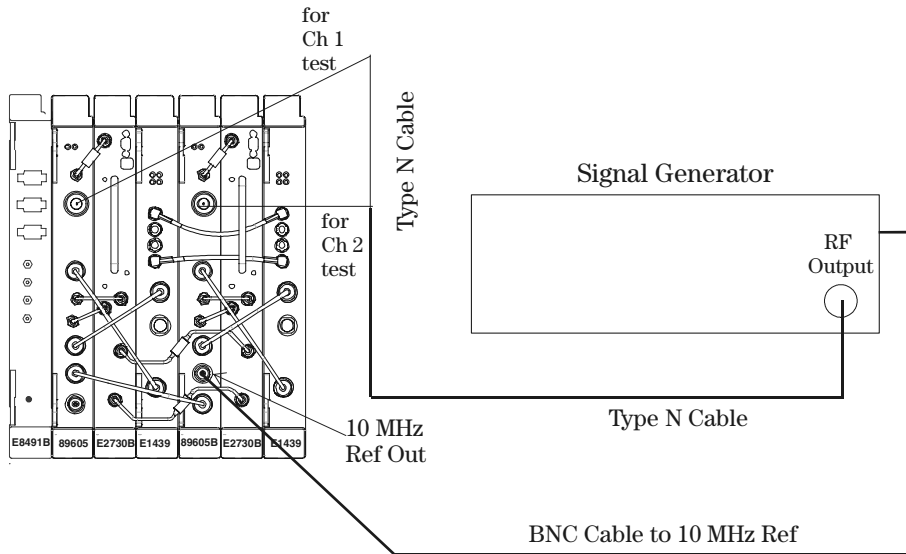

Figure 21

Test setup: 89640A Sideband Spurs

## 89640A Phase Noise

This test verifies the phase noise specifications of the 89640A. Phase noise is a measure of the frequency jitter or frequency instability of a narrow frequency measurement. Phase noise is measured in dB of power relative to carrier power, per Hz of bandwidth (dBc/Hz). A signal generator supplies a clean low phase noise signal to the analyzer.

The 89640A C/No band power marker is used to convert the dBm level to noise by calculating the noise bandwidth. The noise bandwidth is the frequency resolution, adjusted for the effects of the FFT window.

Before the Phase Noise test is performed, the step attenuator calibration factors must be entered using the Attenuator Cal procedure (page 11).

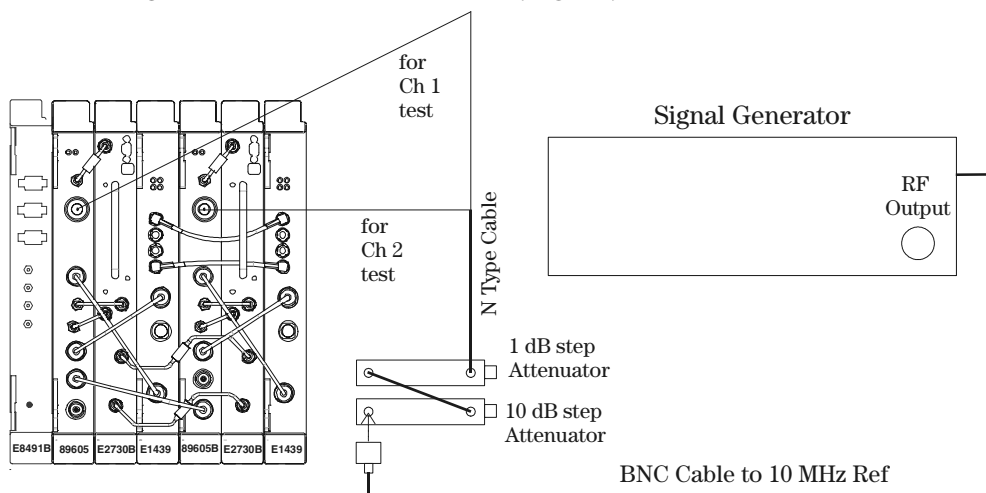

Figure 22

Test setup: 89640A Phase Noise

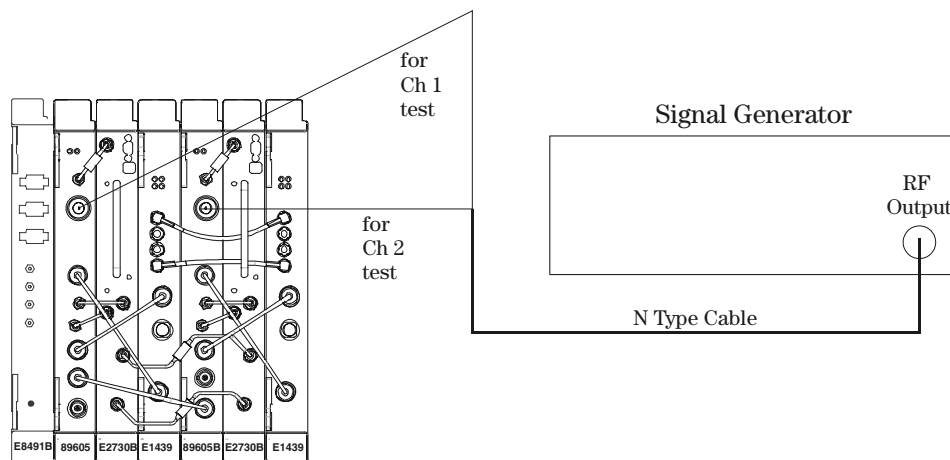

Figure 23

Test setup 2: 89640A Phase Noise

## 89640 Amplitude Linearity

This test verifies that the HP 89640A meets its amplitude accuracy specification for amplitude linearity. The test sets the 89640A's range to 0 dBm. A source is set for full scale input through the external attenuators. The signal is then measured. The value measured is recorded as the reference level. The attenuators are then stepped down and measurements made relative to the full-scale signal.

Averaging is used for all measurements to improve repeatability and reduce measurement uncertainty.

If the power sensor cal factors are not stored in the sensor then the operator must manually center the data into the power meter.

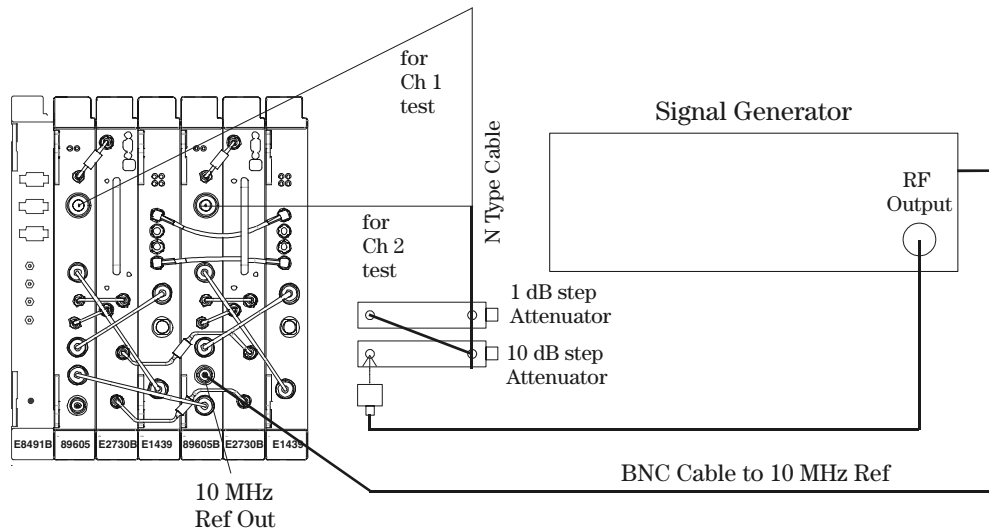

Figure 24

Test setup: 89640A Amplitude Linearity

## 89640 Frequency Accuracy

The purpose of this test is to determine in a reasonable amount of time, that the frequency reference is functional; to provide a measured frequency value, and to suggest that an adjustment be made if the yearly allowable frequency offset value is exceeded.

With the instrument set to internal reference mode, and following a minimum warm-up time of 24 hours, the frequency of the signal analyzer's frequency reference is measured using a counter locked to a frequency standard. The measured value is compared to the allowable offset guideline, and is also printed on the performance test print out.

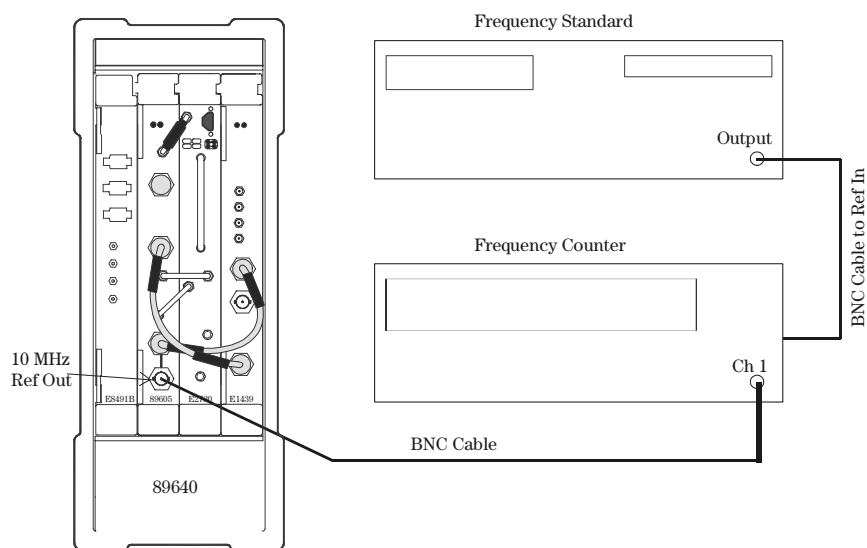

Figure 25

Test setup: 89640A Frequency Accuracy

## 89640 Amplitude Accuracy

This test verifies that the 89640A meets its amplitude accuracy specification for absolute full-scale accuracy. In this test, a signal generator outputs a signal to the power splitter. A power meter measures one output of the power splitter. The analyzer measures the other output. The two measurements are then compared. Band 2 is tested on several different ranges and frequency settings from 10 MHz to 36 MHz with the source signal at the center frequency. Band 1 is tested on several different ranges and frequency settings from 36 MHz to 2.7 GHz with the source signal at the center frequency and at offsets from the center frequency.

To improved amplitude accuracy, the power splitter is characterized using a power sensor (the “reference” sensor) connected to one power splitter output port. The other power splitter output port connects to the “buried” sensor; it is not removed from the power splitter. Once the characterization is done, the reference sensor is removed and replaced by the analyzer.

If the power sensor cal factors are not stored in the sensor then the operator must manually center the data into the power meter.

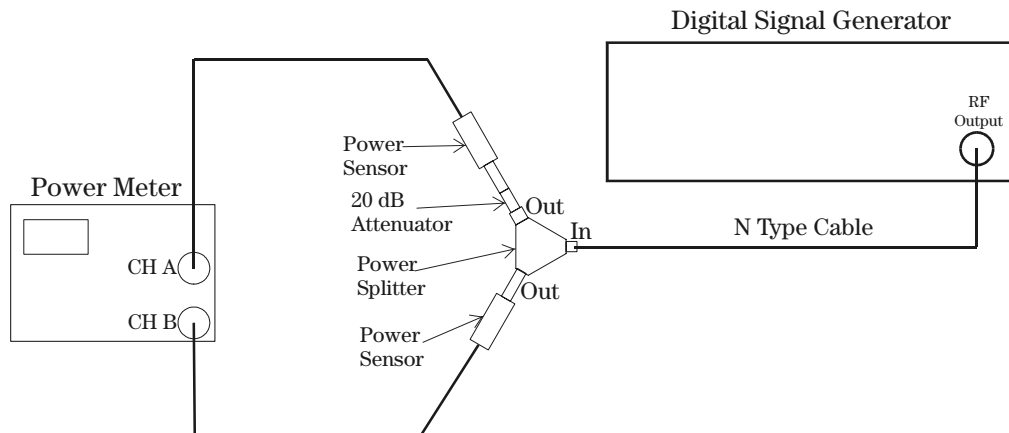

Figure 26

Test setup: Characterize the power splitter

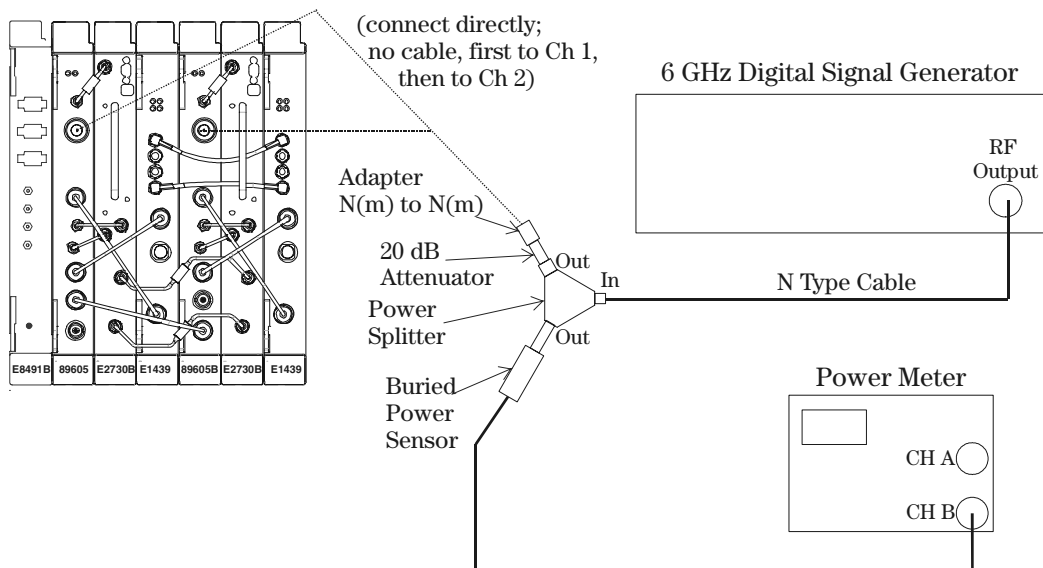

Figure 27

Test setup: 89640A Amplitude Accuracy

---

## 89611A Tests

---

**Note**

The input module shown in all test setups is the 89605B. The 89605A shown here has no Ext Ref In connector, and the three Ext Ref Out connectors (5) are moved down on the module front panel.

---

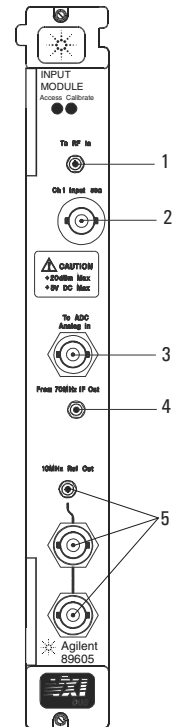

---

## Running the Program

Click **Start, Program Files, Agilent 89600 VSA, Performance Tests**.

Perform the activities under Before Running the Procedures (page 5).

Click the **Run** button.

Connect test equipment as instructed, referring to the figures on the following pages.

---

### Note

The figures for most of the tests show connections for a 2-channel analyzer. For a 1-channel analyzer, just connect the equipment as shown for channel 1 of the 2-channel analyzer.

The 89611A performance test includes the following procedures:

- Auto Calibrate
- IF Residual Response
- Input Noise
- Input VSWR
- Channel Match (for 2-channel analyzers only)
- Intermodulation Distortion
- Harmonic Distortion
- Sideband Spurs
- Phase Noise
- Amplitude Linearity
- Frequency Accuracy
- Amplitude Accuracy

---

## Test Duration

The 89611A procedures require approximately 2 hours.

**89611A Auto Calibrate**

No test equipment is required for this procedure.

## 89611 IF Residual Response

This test verifies the 89611A dynamic range specification for residual responses. A  $50\Omega$  load is connected to the each input channel and a full-span measurement is done with a narrow resolution bandwidth.

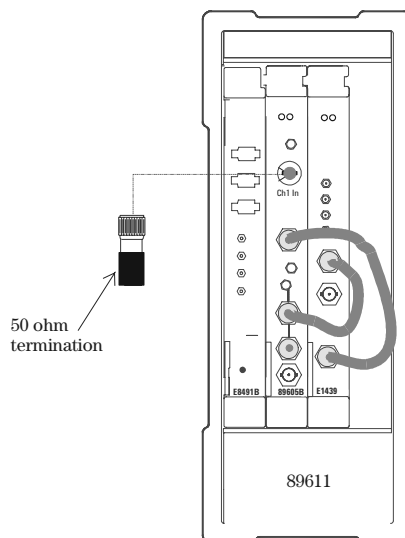

Figure 28

Test setup: 89611A Residual Response

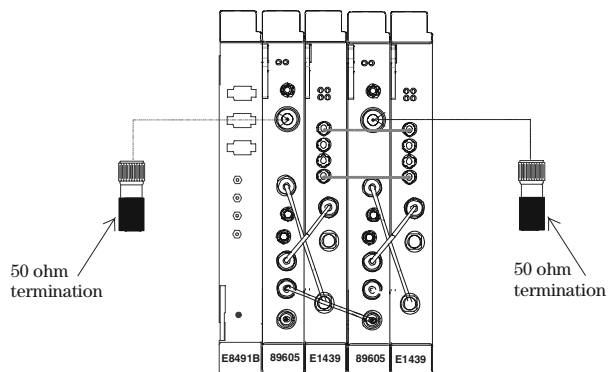

Figure 29

Test setup: 2-channel 89611A Residual Response

## 89611A Input Noise

This test verifies that the 89611A meets the dynamic range specification for input noise density and sensitivity. Noise is measured in dBfs/Hz, or power relative to full scale per Hz of bandwidth. Noise is specified as sensitivity, dBm/Hz, on the most sensitive range.

The noise measurements are made using a wide span and power spectrum density trace. Measurements are made on several low range settings and frequency offsets. Three marker readings are taken and the middle value recorded as the noise level, to assure a noise measurement is being done instead of a spurious response measurement.

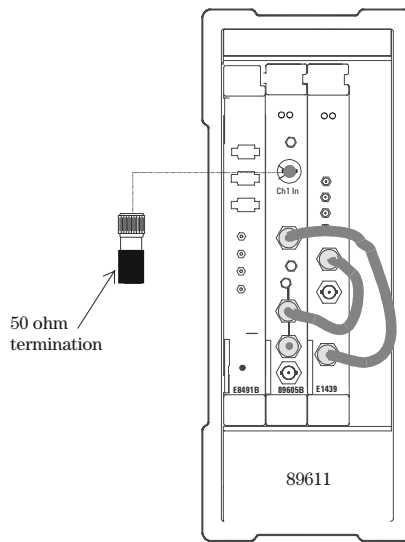

**Figure 30** Test setup: 89611A Noise

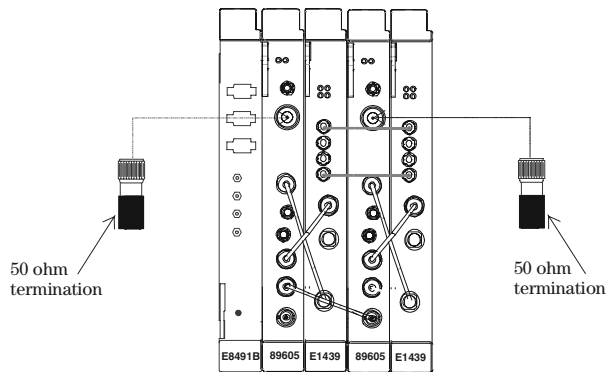

**Figure 31** Test setup: 2-channel 89611A Residual Response

## 89611A Input VSWR

This test measures the return loss of the 89611A on ranges -10, -20, and -30 dBm. A vector network analyzer is configured and calibrated to perform a one port S11 measurement.

Formula for computing VSWR from return loss:

$$\rho = 10^{\text{Return Loss}/-20}$$

$$\text{VSWR} = (1+\rho)/(1-\rho)$$

Before the input VSWR test is performed, the network analyzer must be calibrated using the Network Analyzer Cal procedure (page 10).

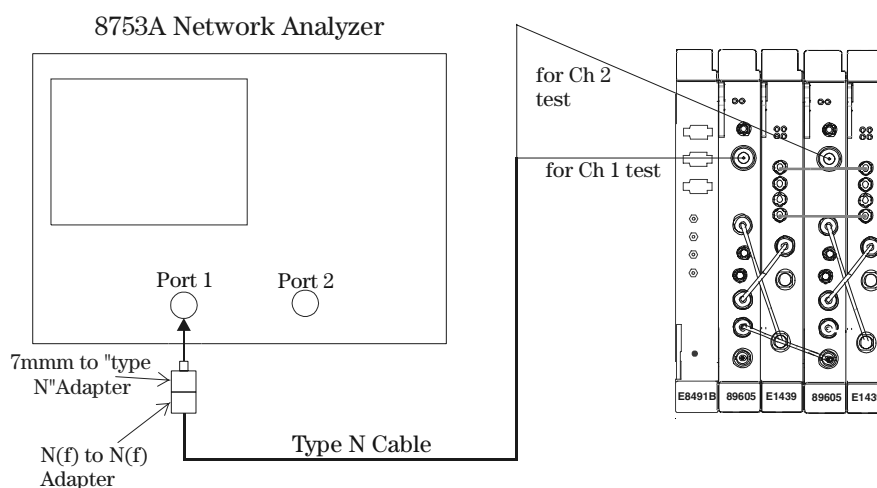

Figure 32

Test setup: 89611A Input VSWR

## 89611 Channel Match

This test measures the amplitude match between the channels of a 2-channel 89611A system. A Gaussian noise signal is applied to both channels through a power splitter. A frequency response measurement is made and saved. The splitter ports are swapped and the measurement repeated. A splitter calibration trace is calculated from these two measurements. A frequency response measurement is then made with the splitter calibration trace applied to the measurement.

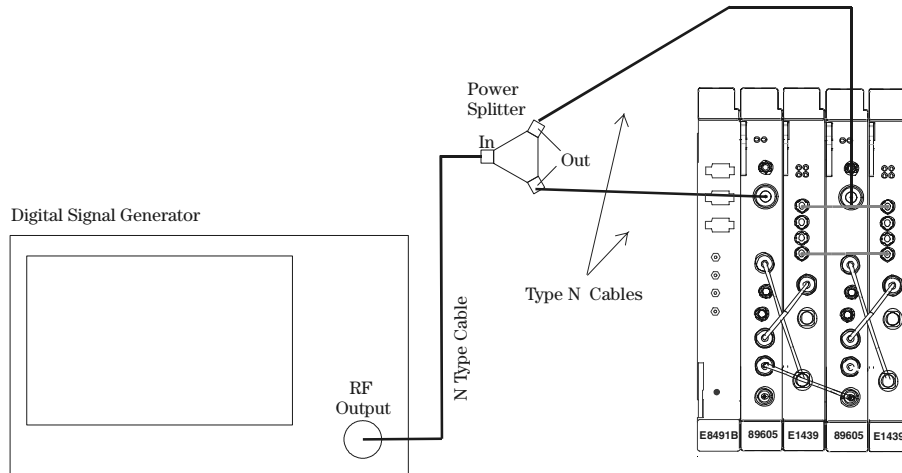

Figure 33

Test setup: 89611A Channel Match

## 89611 Intermodulation Distortion

This test measures the 2nd and 3rd order Intermodulation distortion of the analyzer with a 0.8 MHz tone separation for the base band measurements. This separation is used so the products of the input signals are in-band. A 1.1 MHz separation of the tones is used for the RF Band. A low range setting of -30 dBm is used to avoid requiring a high output from the sources.

Two signals are combined using a directional bridge and applied to the analyzer's input. A filter is used on one of the sources to reduce the 2nd order distortion product from Source 1. The sources are set for -6.5 dB full-scale on the analyzer. The analyzer then measures the amplitude of the distortion products relative to Source 1.

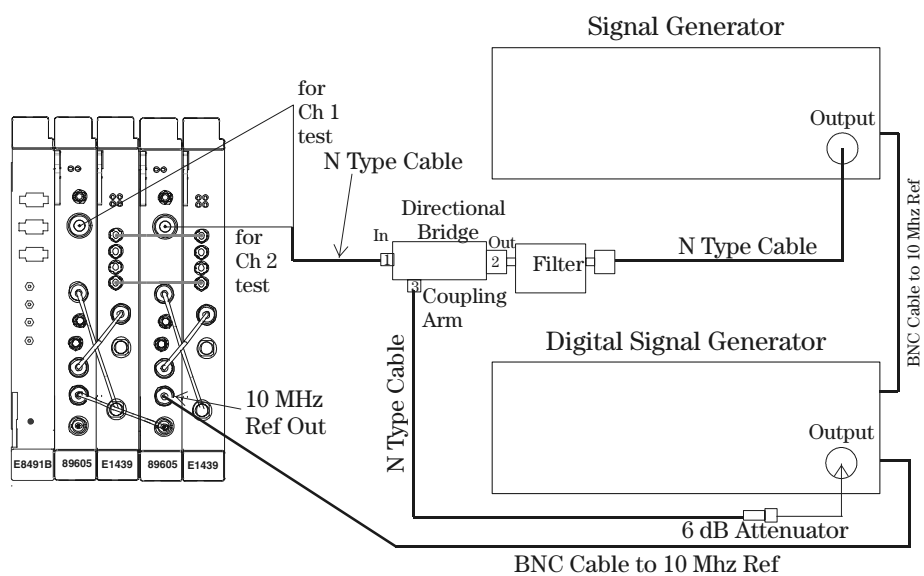

Figure 34

Test setup: 89611A Intermodulation Distortion

## 89611 Harmonic Distortion

This test verifies that the 89611A meets its dynamic range specification for harmonic distortion. In this test, a low pass filter attenuates the harmonics of the signal from the synthesizer. The analyzer measures the source signal and adjusts the synthesizer level for -0.5 dBfs. The analyzer then measures the second and third harmonics. If the harmonics are out-of-band the alias of the harmonic is measured.

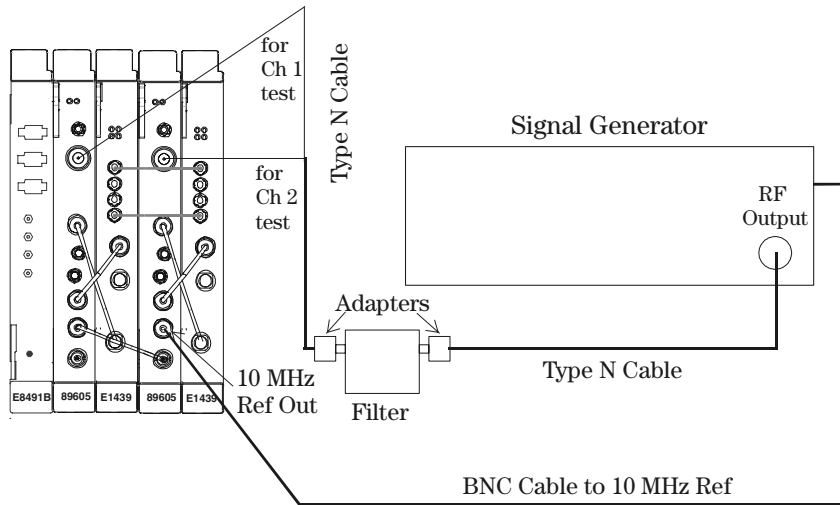

Figure 35

Test setup: 89611A Harmonic Distortion

## 89611A Sideband Spurs

This test verifies that the 89611A meets its dynamic range specification for sideband spurs (non-harmonic) signals. In this test, a signal generator supplies a clean signal to the analyzer. The analyzer measures the sideband spurs relative to the input signal.

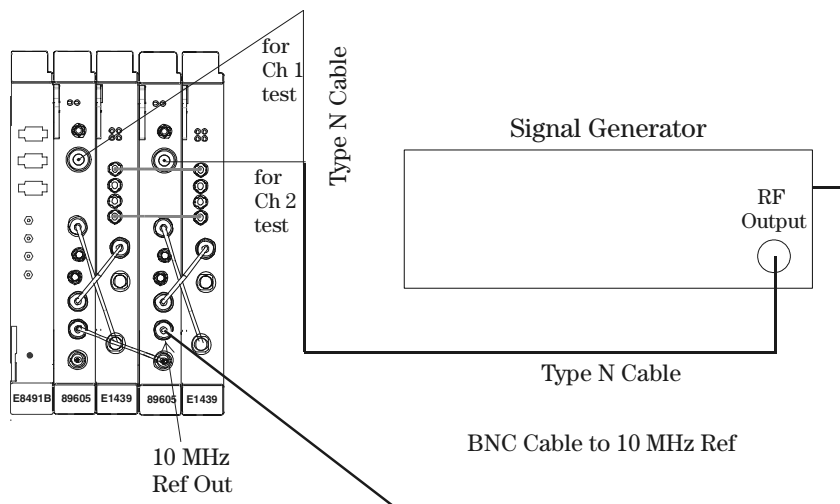

Figure 36

Test setup: 89611A Sideband Spurs

**89611A Phase Noise**

This test verifies the phase noise specifications of the 89611A. Phase noise is a measure of the frequency jitter or frequency instability of a narrow frequency measurement. Phase noise is measured in dB of power relative to carrier power, per Hz of bandwidth (dBc/Hz). A signal generator supplies a clean low phase noise signal to the analyzer.

The 89611A C/No band power marker is used to convert the dBm level to noise by calculating the noise bandwidth. The noise bandwidth is the frequency resolution, adjusted for the effects of the FFT window.

Before the Phase Noise test is performed, the step attenuator calibration factors must be entered using the Attenuator Cal procedure (page 11).

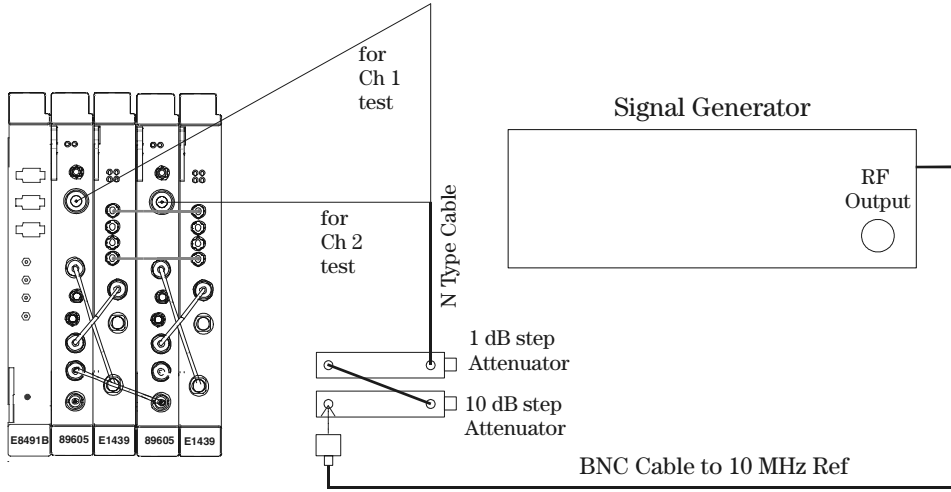

**Figure 37**

**Test setup: 89611A Phase Noise**

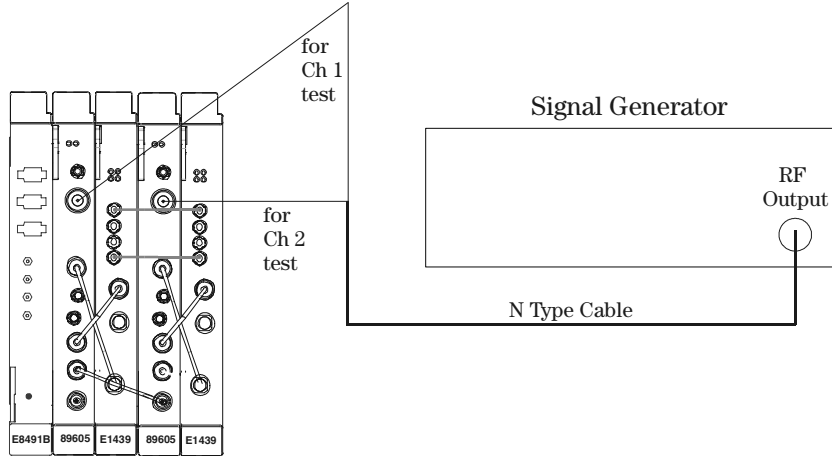

**Figure 38**

**Test setup 2: 89611A Phase Noise**

## 89611 Amplitude Linearity

This test verifies that the HP 89611A meets its amplitude accuracy specification for amplitude linearity. The test sets the 89611A's range to 0 dBm. A source is set for full scale input through the external attenuators. The signal is then measured. The value measured is recorded as the reference level. The attenuators are then stepped down and measurements made relative to the full-scale signal.

Averaging is used for all measurements to improve repeatability and reduce measurement uncertainty.

If the power sensor cal factors are not stored in the sensor then the operator must manually center the data into the power meter.

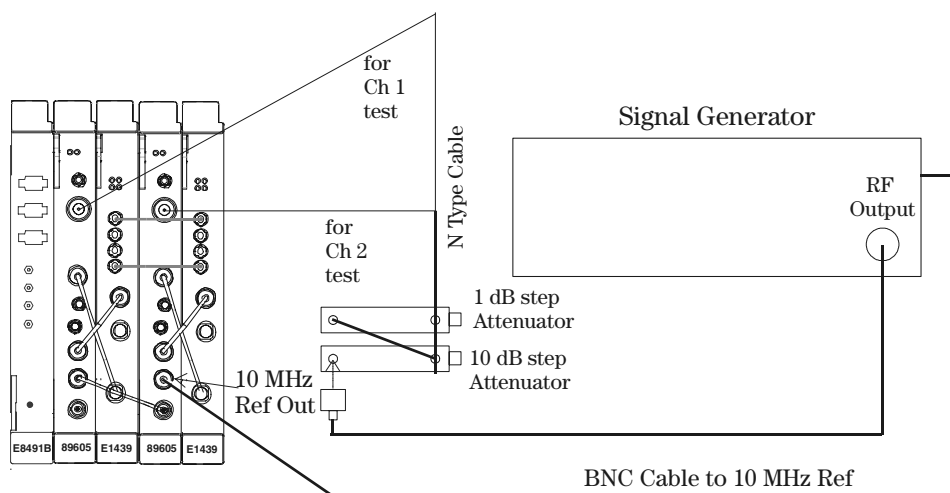

Figure 39

Test setup: 89611A Amplitude Linearity

## 89611 Frequency Accuracy

The purpose of this test is to determine in a reasonable amount of time, that the frequency reference is functional; to provide a measured frequency value, and to suggest that an adjustment be made if the yearly allowable frequency offset value is exceeded.

With the instrument set to internal reference mode, and following a minimum warm-up time of 24 hours, the frequency of the signal analyzer's frequency reference is measured using a counter locked to a frequency standard. The measured value is compared to the allowable offset guideline, and is also printed on the performance test print out.

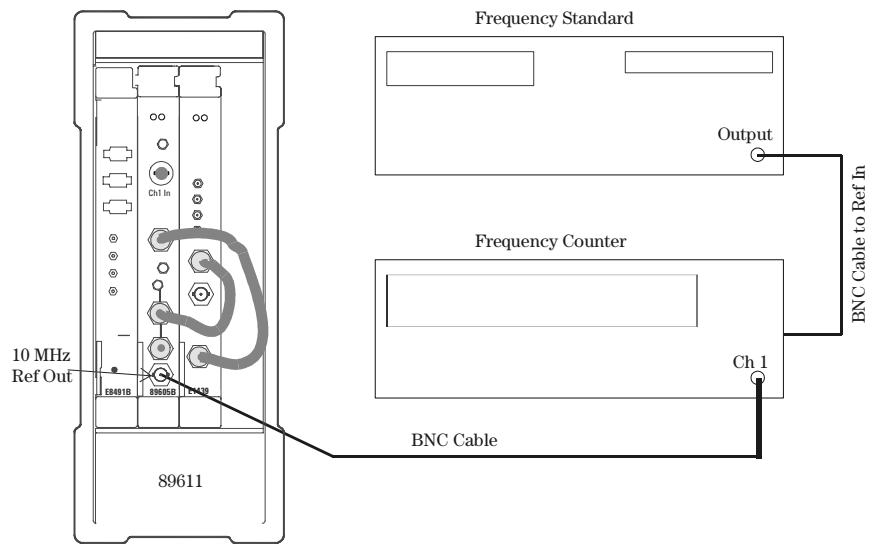

Figure 40

Test setup: 89611A Frequency Accuracy

## 89611 Amplitude Accuracy

This test verifies that the 89611A meets its amplitude accuracy specification for absolute full-scale accuracy. In this test, a signal generator outputs a signal to the power splitter. A power meter measures one output of the power splitter. The analyzer measures the other output. The two measurements are then compared. Band 2 is tested on several different ranges and frequency settings from 10 MHz to 36 MHz with the source signal at the center frequency. Band 1 is tested on several different ranges and frequency settings from 52.1 to 87.9 MHz.

To improved amplitude accuracy, the power splitter is characterized using a power sensor (the “reference” sensor) connected to one power splitter output port. The other power splitter output port connects to the “buried” sensor; it is not removed from the power splitter. Once the characterization is done, the reference sensor is removed and replaced by the analyzer.

If the power sensor cal factors are not stored in the sensor then the operator must manually center the data into the power meter.

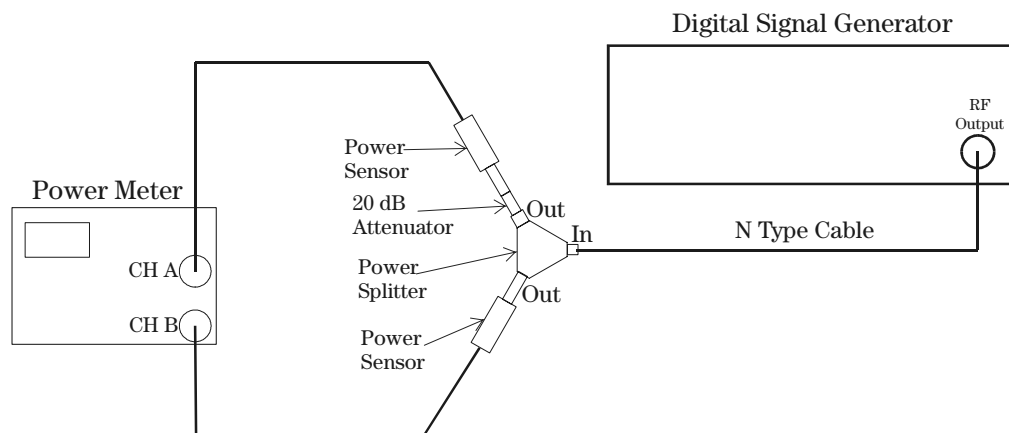

Figure 41

Test setup: Characterize the power splitter

## 89611A Tests

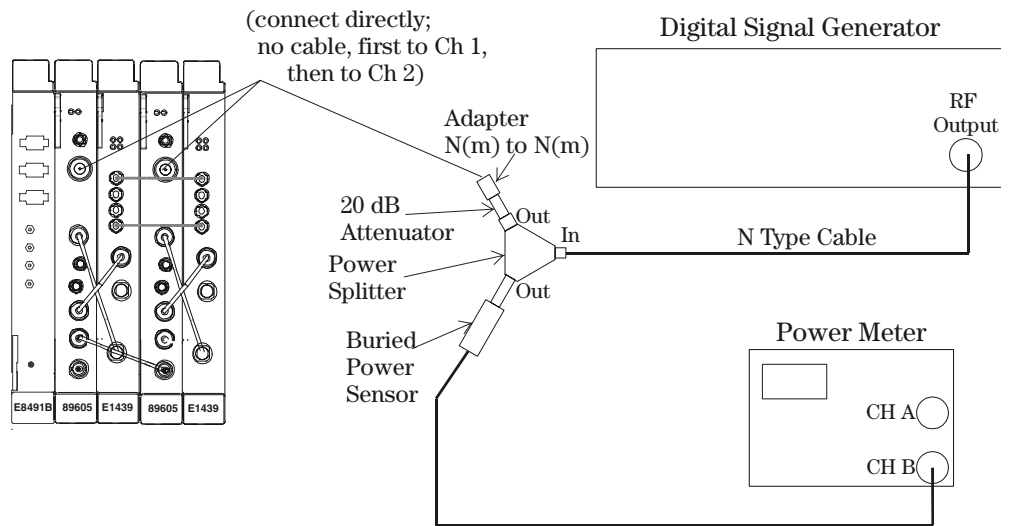

Figure 42

Test setup: 89611A Amplitude Accuracy

---

## 89641A Tests

---

### Note

The input module shown in all test setups is the 89605A. The 89605B shown here has an Ext Ref In connector (1) at the bottom of the module, and the three Ext Ref Out connectors (2) are moved up on the module front panel.

---

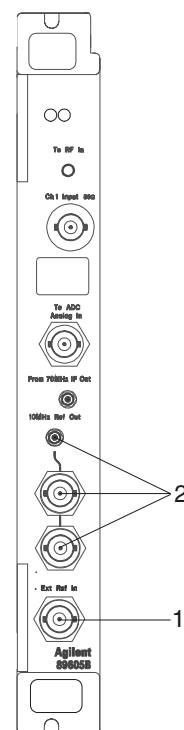

## Running the Program

Click **Start, Program Files, Agilent 89600 VSA, Performance Tests**.

Perform the activities under Before Running the Procedures (page 5).

Click the **Run** button.

Connect test equipment as instructed, referring to the figures on the following pages.

---

### Note

The figures for most of the tests show connections for a 2-channel analyzer. For a 1-channel analyzer, just connect the equipment as shown for channel 1 of the 2-channel analyzer.

The 89641A performance test includes the following procedures:

- Auto Calibrate
- Residual Response
- Noise
- Input VSWR
- Channel Match (for 2-channel analyzers only)
- Intermodulation Distortion
- Harmonic Distortion
- Sideband Spurs
- Phase Noise
- Amplitude Linearity
- Frequency Accuracy
- Amplitude Accuracy

---

## Test Duration

The 89641A procedures require approximately 2.5 hours.

---

## 89641A Auto Calibrate

No test equipment is required for this procedure.

---

## 89641 Residual Response

This test verifies the 89641A dynamic range specification for residual responses. A 50Ω load is connected to the each input channel and a full-span measurement is done with a narrow resolution bandwidth.

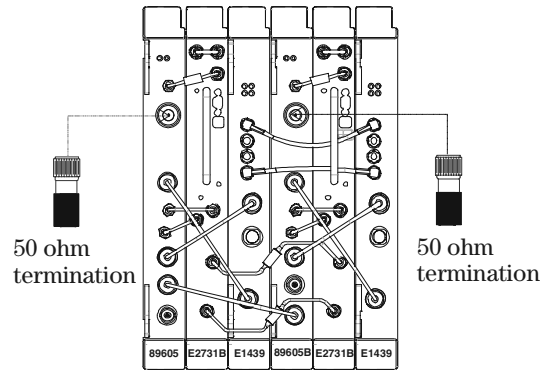

Figure 43

Test setup: 89641A Residual Response

## 89641A Noise

This test verifies that the 89641A meets the dynamic range specification for input noise density and sensitivity. Noise is measured in dBfs/Hz, or power relative to full scale per Hz of bandwidth. Noise is specified as sensitivity, dBm/Hz, on the most sensitive range.

The noise measurements are made using a wide span and power spectrum density trace. Measurements are made on several low range settings and frequency offsets. Three marker readings are taken and the middle value recorded as the noise level, to assure a noise measurement is being done instead of a spurious response measurement.

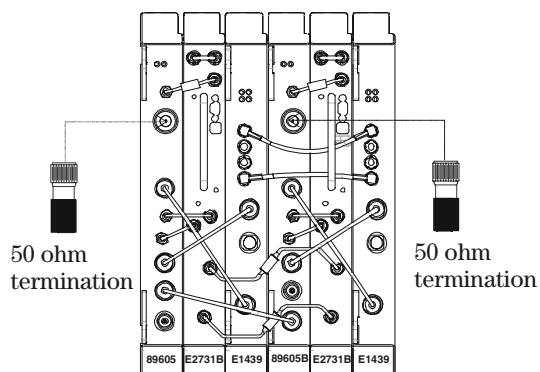

Figure 44

Test setup: 89641A Noise

## 89641A Input VSWR

This test measures the return loss of the 89641A on ranges -10, -20, and -30 dBm. A vector network analyzer is configured and calibrated to perform a one port S11 measurement.

Formula for computing VSWR from return loss:

$$\rho = 10^{\text{Return Loss}/-20}$$

$$\text{VSWR} = (1+\rho)/(1-\rho)$$

Before the input VSWR test is performed, the network analyzer must be calibrated using the Network Analyzer Cal procedure (page 10).

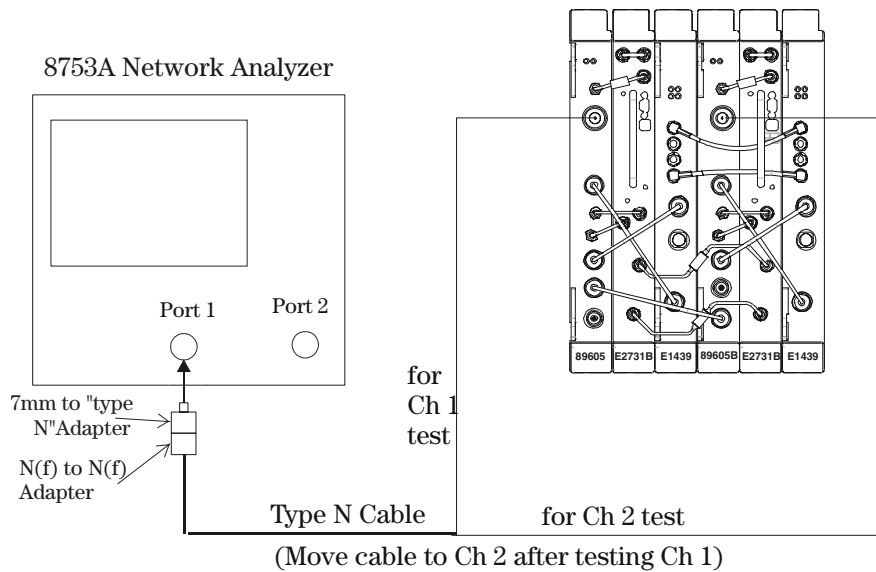

Figure 45

Test setup: 89641A Input VSWR

## 89641A Channel Match

This test measures the amplitude match between the channels of a 2-channel 89641A system. A Gaussian noise signal is applied to both channels through a power splitter. A frequency response measurement is made and saved. The splitter ports are swapped and the measurement repeated. A splitter calibration trace is calculated from these two measurements. A frequency response measurement is then made with the splitter calibration trace applied to the measurement.

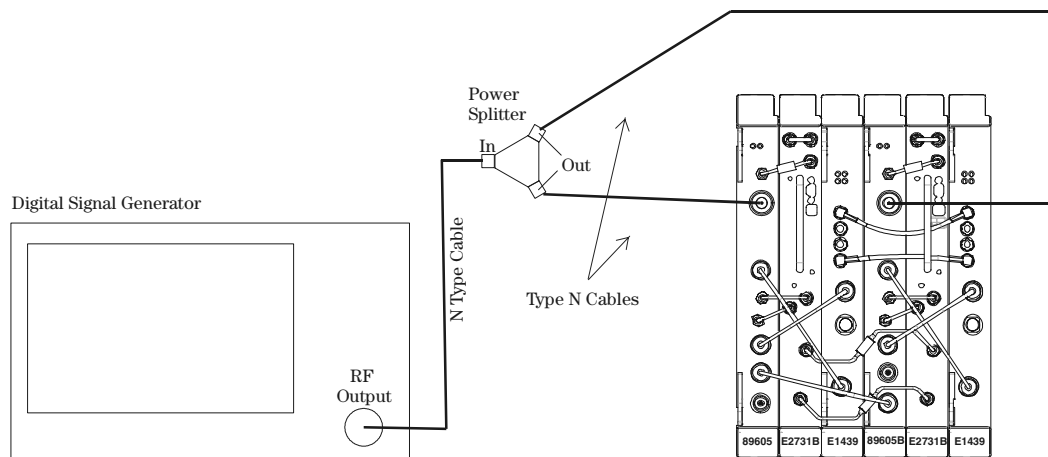

Figure 46

Test setup: 89641A Channel Match

## 89641A Intermodulation Distortion

This test measures the 2nd and 3rd order Intermodulation distortion of the analyzer with a 0.8 MHz tone separation for the base band measurements. This separation is used so the products of the input signals are in-band. A 1.1 MHz separation of the tones is used for the RF Band. A low range setting of -30 dBm is used to avoid requiring a high output from the sources.

Two signals are combined using a directional bridge and applied to the analyzer's input. A filter is used on one of the sources to reduce the 2nd order distortion product from Source 1. The sources are set for -6.5 dB full-scale on the analyzer. The analyzer then measures the amplitude of the distortion products relative to Source 1.

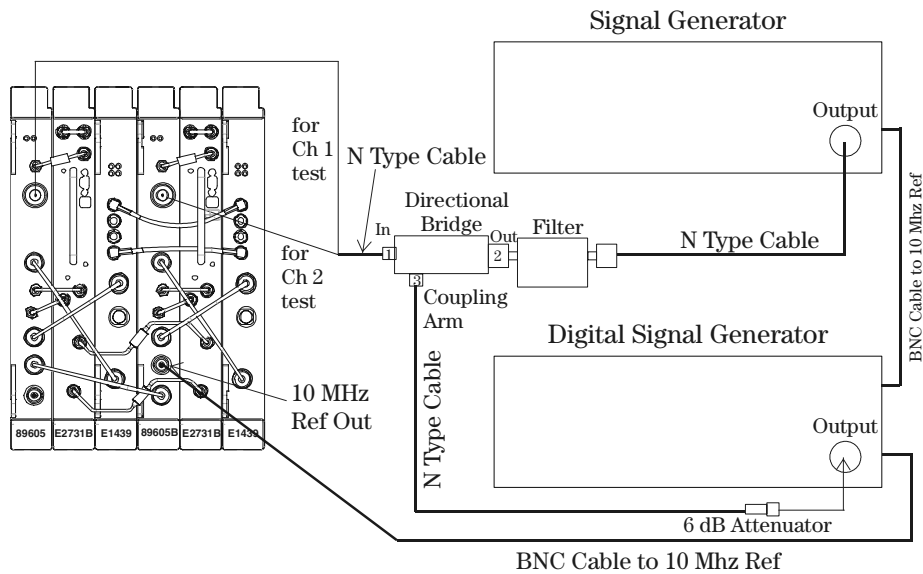

Figure 47

Test setup: 89641A Intermodulation Distortion

## 89641 Harmonic Distortion

This test verifies that the 89641A meets its dynamic range specification for harmonic distortion. In this test, a low pass filter attenuates the harmonics of the signal from the synthesizer. The analyzer measures the source signal and adjusts the synthesizer level for -0.5 dBfs. The analyzer then measures the second and third harmonics. If the harmonics are out-of-band the alias of the harmonic is measured.

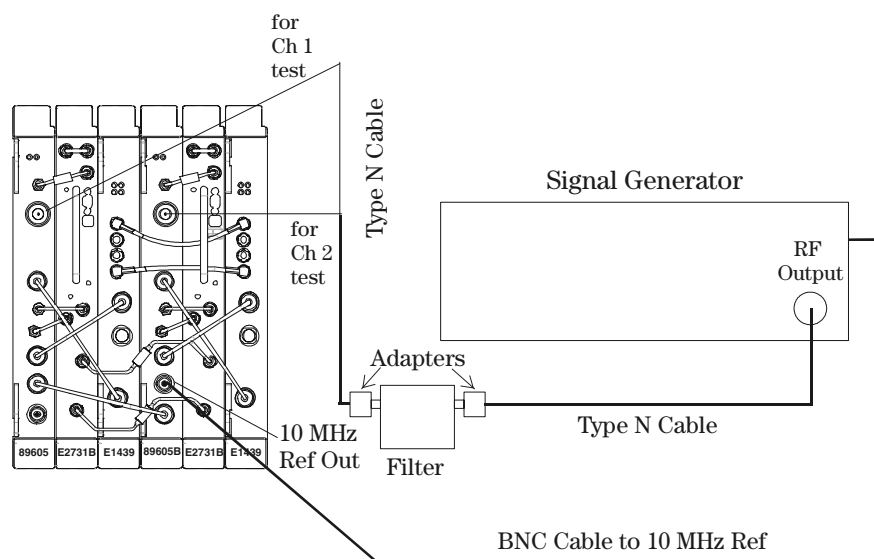

Figure 48

Test setup: 89641A Harmonic Distortion

### 89641A Sideband Spurs

This test verifies that the 89641A meets its dynamic range specification for sideband spurs (non-harmonic) signals. In this test, a signal generator supplies a clean signal to the analyzer. The analyzer measures the sideband spurs relative to the input signal.

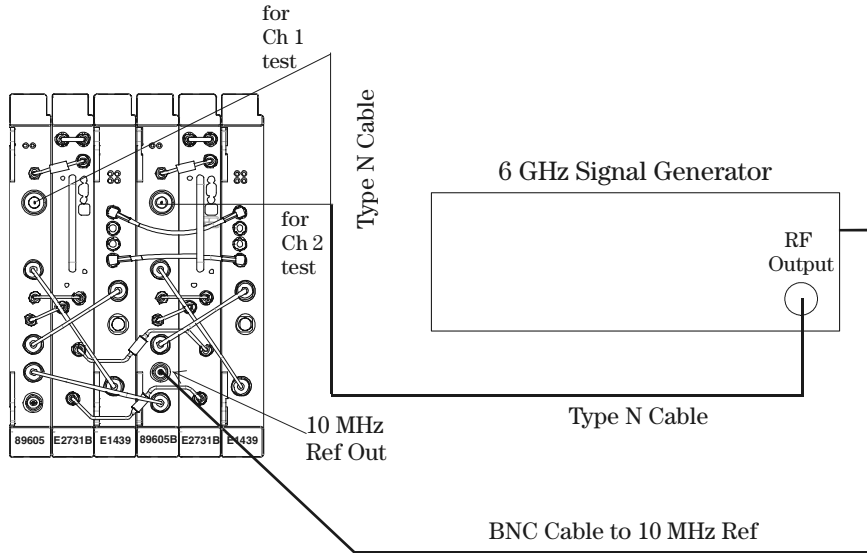

Figure 49

Test setup: 89641A Sideband Spurs

## 89641A Phase Noise

This test verifies the phase noise specifications of the 89641A. Phase noise is a measure of the frequency jitter or frequency instability of a narrow frequency measurement. Phase noise is measured in dB of power relative to carrier power, per Hz of bandwidth (dBc/Hz). A signal generator supplies a clean low phase noise signal to the analyzer.

The 89641A C/No band power marker is used to convert the dBm level to noise by calculating the noise bandwidth. The noise bandwidth is the frequency resolution, adjusted for the effects of the FFT window.

Before the Phase Noise test is performed, the step attenuator calibration factors must be entered using the Attenuator Cal procedure (page 11).

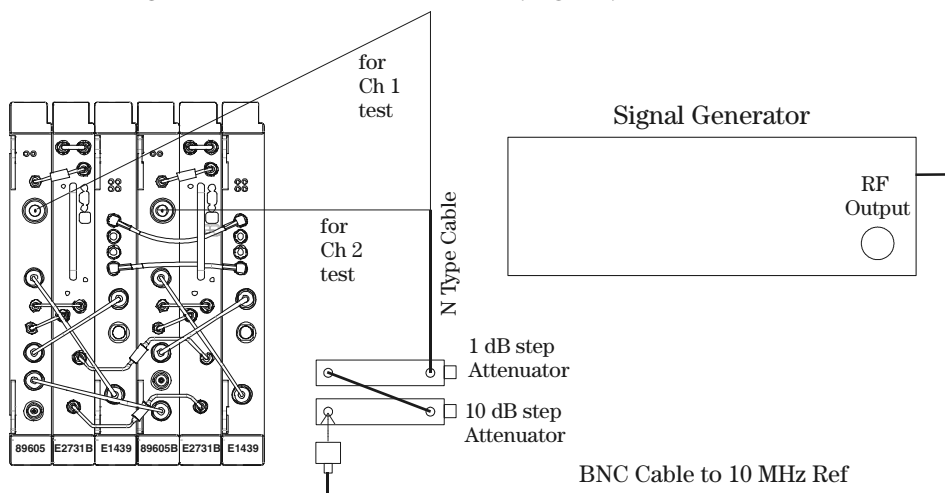

Figure 50

Test setup: 89641A Phase Noise

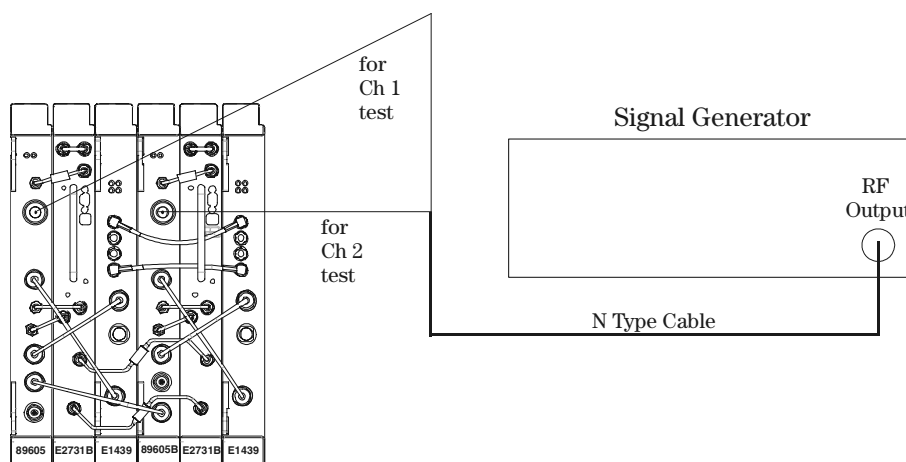

Figure 51

Test setup 2: 89641A Phase Noise

## 89641A Amplitude Linearity

This test verifies that the HP 89641A meets its amplitude accuracy specification for amplitude linearity. The test sets the 89641A's range to 0 dBm. A source is set for full scale input through the external attenuators. The signal is then measured. The value measured is recorded as the reference level. The attenuators are then stepped down and measurements made relative to the full-scale signal.

Averaging is used for all measurements to improve repeatability and reduce measurement uncertainty.

If the power sensor cal factors are not stored in the sensor then the operator must manually center the data into the power meter.

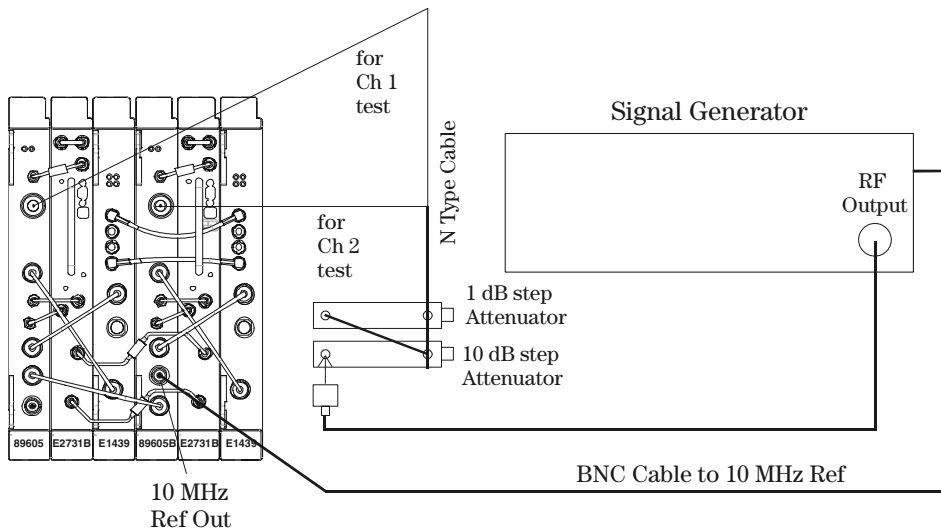

Figure 52

Test setup: 89641A Amplitude Linearity

## 89641A Frequency Accuracy

The purpose of this test is to determine in a reasonable amount of time, that the frequency reference is functional; to provide a measured frequency value, and to suggest that an adjustment be made if the yearly allowable frequency offset value is exceeded.

With the instrument set to internal reference mode, and following a minimum warm-up time of 24 hours, the frequency of the signal analyzer's frequency reference is measured using a counter locked to a frequency standard. The measured value is compared to the allowable offset guideline, and is also printed on the performance test print out.

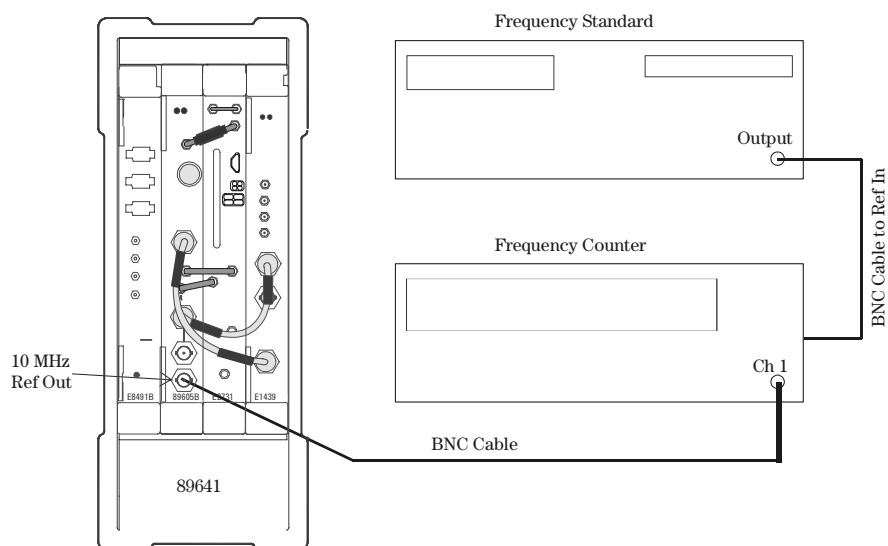

Figure 53

Test setup: 89641A Frequency Accuracy

## 89641A Amplitude Accuracy

This test verifies that the 89641A meets its amplitude accuracy specification for absolute full-scale accuracy. In this test, a signal generator outputs a signal to the power splitter. A power meter measures one output of the power splitter. The analyzer measures the other output. The two measurements are then compared. Band 2 is tested on several different ranges and frequency settings from 10 MHz to 36 MHz with the source signal at the center frequency. Band 1 is tested on several different ranges and frequency settings from 36 MHz to 6 GHz with the source signal at the center frequency and at offsets from the center frequency.

To improved amplitude accuracy, the power splitter is characterized using a power sensor (the “reference” sensor) connected to one power splitter output port. The other power splitter output port connects to the “buried” sensor; it is not removed from the power splitter. Once the characterization is done, the reference sensor is removed and replaced by the analyzer.

If the power sensor cal factors are not stored in the sensor then the operator must manually center the data into the power meter.

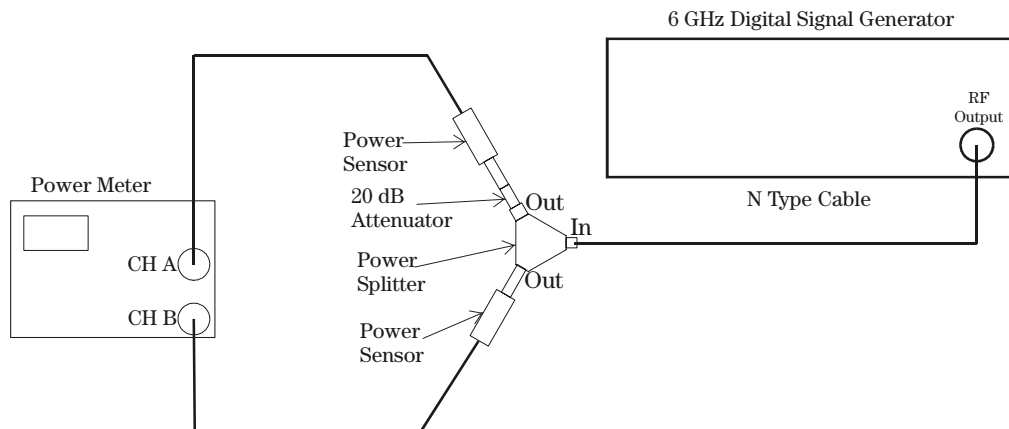

Figure 54

Test setup: Characterize the power splitter

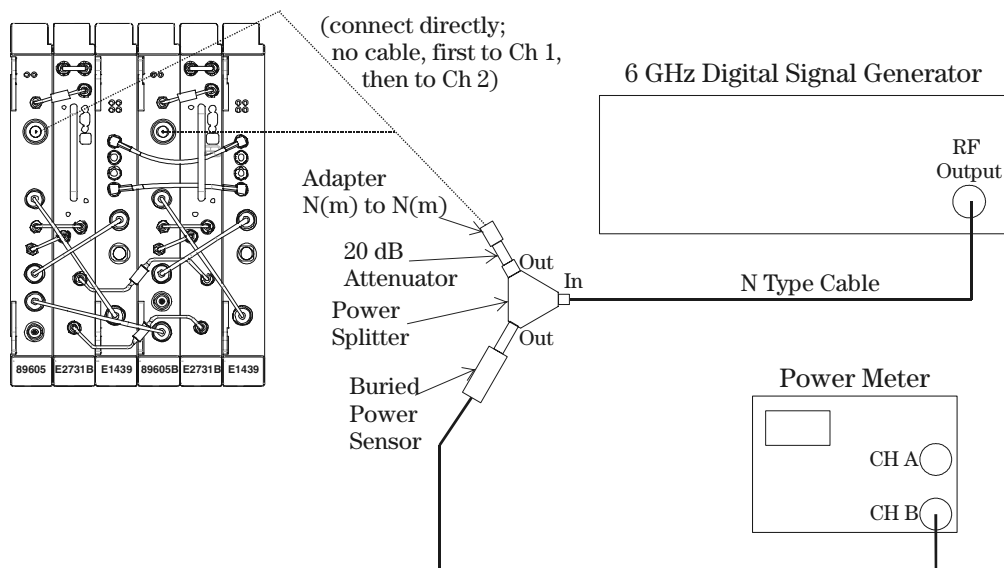

Figure 55

Test setup: 89641A Amplitude Accuracy

# Error Messages

If you encounter the error message shown here, you must upgrade your 89600 software to version 5.00 or later.

