

Keysight U8480 Series USB Thermocouple Power Sensor

Notices

Copyright Notice

© Keysight Technologies 2013 - 2020
No part of this manual may be reproduced in any form or by any means (including electronic storage and retrieval or translation into a foreign language) without prior agreement and written consent from Keysight Technologies as governed by United States and international copyright laws.

Manual Part Number

U8481-90004

Edition

Edition 8, March 19, 2020

Printed in:

Printed in Malaysia

Published by:

Keysight Technologies
Bayan Lepas Free Industrial Zone,
11900 Penang, Malaysia

Technology Licenses

The hardware and/or software described in this document are furnished under a license and may be used or copied only in accordance with the terms of such license.

Declaration of Conformity

Declarations of Conformity for this product and for other Keysight products may be downloaded from the Web. Go to <http://www.keysight.com/go/conformity>. You can then search by product number to find the latest Declaration of Conformity.

U.S. Government Rights

The Software is "commercial computer software," as defined by Federal Acquisition Regulation ("FAR") 2.101. Pursuant to FAR 12.212 and 27.405-3 and Department of Defense FAR Supplement ("DFARS") 227.7102, the U.S. government acquires commercial computer software under the same terms by which the software is customarily provided to the public. Accordingly, Keysight provides the Software to U.S. government customers under its standard commercial license, which is embodied in its End User License Agreement (EULA), a copy of which can be found at <http://www.keysight.com/find/sweula>. The license set forth in the EULA represents the exclusive authority by which the U.S. government may use, modify, distribute, or disclose the Software. The EULA and the license set forth therein, does not require or permit, among other things, that Keysight: (1) Furnish technical information related to commercial computer software or commercial computer software documentation that is not customarily provided to the public; or (2) Relinquish to, or otherwise provide, the government rights in excess of these rights customarily provided to the public to use, modify, reproduce, release, perform, display, or disclose commercial computer software or commercial computer software documentation. No additional government requirements beyond those set forth in the EULA shall apply, except to the extent that those terms, rights, or licenses are explicitly required from all providers of commercial computer software pursuant to the FAR and the DFARS and are set forth specifically in writing elsewhere in the EULA. Keysight shall be under no obligation to update, revise or otherwise modify the Software. With respect to any technical data as defined by FAR 2.101, pursuant to FAR 12.211 and 27.404.2 and DFARS 227.7102, the U.S. government acquires no greater than Limited Rights as defined in FAR 27.401 or DFAR 227.7103-5 (c), as applicable in any technical data.

Warranty

THE MATERIAL CONTAINED IN THIS DOCUMENT IS PROVIDED "AS IS," AND IS SUBJECT TO BEING CHANGED, WITHOUT NOTICE, IN FUTURE EDITIONS. FURTHER, TO THE MAXIMUM EXTENT PERMITTED BY APPLICABLE LAW, KEYSIGHT DISCLAIMS ALL WARRANTIES, EITHER EXPRESS OR IMPLIED, WITH REGARD TO THIS MANUAL AND ANY INFORMATION CONTAINED HEREIN, INCLUDING BUT NOT LIMITED TO THE IMPLIED WARRANTIES OF MERCHANTABILITY AND FITNESS FOR A PARTICULAR PURPOSE. KEYSIGHT SHALL NOT BE LIABLE FOR ERRORS OR FOR INCIDENTAL OR CONSEQUENTIAL DAMAGES IN CONNECTION WITH THE FURNISHING, USE, OR PERFORMANCE OF THIS DOCUMENT OR OF ANY INFORMATION CONTAINED HEREIN. SHOULD KEYSIGHT AND THE USER HAVE A SEPARATE WRITTEN AGREEMENT WITH WARRANTY TERMS COVERING THE MATERIAL IN THIS DOCUMENT THAT CONFLICT WITH THESE TERMS, THE WARRANTY TERMS IN THE SEPARATE AGREEMENT SHALL CONTROL.

Safety Information

CAUTION





A CAUTION notice denotes a hazard. It calls attention to an operating procedure, practice, or the like that, if not correctly performed or adhered to, could result in damage to the product or loss of important data. Do not proceed beyond a CAUTION notice until the indicated conditions are fully understood and met.

WARNING

A WARNING notice denotes a hazard. It calls attention to an operating procedure, practice, or the like that, if not correctly performed or adhered to, could result in personal injury or death. Do not proceed beyond a WARNING notice until the indicated conditions are fully understood and met.

Safety and Regulatory Symbols

The following symbols on the device and in the documentation indicate precautions that must be taken to maintain safe operation of the device.

 <p>The RCM mark is a registered trademark of the Australian Communications and Media Authority.</p>	 <p>This instrument complies with the WEEE Directive (2002/96/EC) marking requirement. This affixed product label indicates that you must not discard this electrical or electronic product in domestic household waste.</p>
 <p>This symbol indicates the time period during which no hazardous or toxic substance elements are expected to leak or deteriorate during normal use. Forty years is the expected useful life of the product.</p>	 <p>The CE mark is a registered trademark of the European Community. This CE mark shows that the product complies with all the relevant European Legal Directives.</p> <p>ICES/NMB-001 indicates that this ISM device complies with the Canadian ICES-001.</p> <p>Cet appareil ISM est conforme a la norme NMB-001 du Canada.</p> <p>ISM GRP.1 Class A indicates that this is an Industrial Scientific and Medical Group 1 Class A product.</p>

General Safety Information

The following general safety precautions must be observed during all phases of operation, service, and repair of this device. Failure to comply with these precautions or with specific warnings elsewhere in this manual violates safety standards of design, manufacture, and intended use of the device. Keysight Technologies assumes no liability for the customer's failure to comply with these requirements.

WARNING

Before connecting the sensor to other instruments, ensure that all instruments are connected to the protective (earth) ground. Any interruption of the protective earth grounding will cause a potential shock hazard that could result in personal injury.

CAUTION

Repair or service that is not covered in this manual should only be performed by qualified personnel.

Environmental Conditions

This device is designed for indoor use only. The following table shows the general environmental requirements for this device.

Operating environment

Environmental condition	Requirement
Temperature	0 °C to 55 °C
Humidity	Up to 95% RH at 40°C (non-condensing)
Altitude	Operating up to 4.6 km (15000 ft)

Storage condition

Environmental condition	Requirement
Temperature	-40 °C to 71 °C (non-operating)
Humidity	-40 °C to 71 °C (non-operating)
Altitude	Non-operating up to 4.6 km (15000 ft)

Regulatory information

The U8480 Series USB thermocouple power sensor complies with the following EMC requirements:

- IEC 61326-1/EN 61326-1
- Canada: ICES/NMB-001
- Australia/New Zealand: AS/NZS CISPR11

Waste Electrical and Electronic Equipment (WEEE) Directive 2002/96/EC

This instrument complies with the WEEE Directive (2002/96/EC) marking requirement. This affixed product label indicates that you must not discard this electrical or electronic product in domestic household waste.

Product category:

With reference to the equipment types in the WEEE directive Annex 1, this instrument is classified as a “Monitoring and Control Instrument” product.

The affixed product label is as shown below.



Do not dispose in domestic household waste.

To return this unwanted instrument, contact your nearest Keysight Service Center, or visit <http://about.keysight.com/en/companyinfo/environment/takeback.shtml> for more information.

Sales and Technical Support

To contact Keysight for sales and technical support, refer to the support links on the following Keysight websites:

- www.keysight.com/find/usbthermosensor
(product-specific information and support, software and documentation updates)
- www.keysight.com/find/assist
(worldwide contact information for repair and service)

THIS PAGE HAS BEEN INTENTIONALLY LEFT BLANK.

Table of Contents

Safety and Regulatory Symbols	3
General Safety Information	4
Environmental Conditions	5
Operating environment	5
Storage condition	5
Regulatory information	6
Waste Electrical and Electronic Equipment (WEEE) Directive	
2002/96/EC	7
Product category:	7
Sales and Technical Support	7
1 General Information	
Specifications and Characteristics	16
Cleaning	17
Connector care	17
2 Performance Verification and Adjustments	
Equipment List	20
Voltage Standing Wave Ratio (VSWR) Performance Verification	22
Power Linearity Performance Verification	24
Zero Set Performance Verification	27
Internal Calibration Performance Verification	29
Adjustments	31
3 Theory of Operation	
Theory of Operation	34
4 Repair Guide	
Replaceable Parts	38
Disassembly/Reassembly Procedure	41

Disassembly procedure	41
Reassembly procedure	42
5 Contacting Keysight	
Introduction	44
Instrument serial number	44
Recommended calibration interval	45
Returning the U8480 Series for Service	46
Packaging the U8480 Series for shipment	46

List of Figures

Figure 3-1	U8480 Series (AC-coupled) block diagram	34
Figure 4-1	Illustrated parts breakdown	39
Figure 5-1	Serial number	45

THIS PAGE HAS BEEN INTENTIONALLY LEFT BLANK.

List of Tables

Table 4-1	Replaceable parts list for the U8480 Series40
-----------	---	---------

THIS PAGE HAS BEEN INTENTIONALLY LEFT BLANK.

1 General Information

Specifications and Characteristics	16
Cleaning	17

This chapter provides the specifications and maintenance information of the U8480 Series USB Thermocouple Power Sensor.

Specifications and Characteristics

For the characteristics and specifications of the U8480 Series USB Thermocouple Power Sensor, refer to the datasheet at <http://literature.cdn.keysight.com/litweb/pdf/5991-1410EN.pdf>.

Cleaning

Use a clean, water-dampened cloth to clean the body of the U8480 Series.

Connector care

A solution of pure isopropyl or ethyl alcohol can be used to clean the connector but make sure to keep in mind its flammable nature.

CAUTION

- The RF connector beads deteriorate when contacted by hydrocarbon compounds such as acetone, trichloroethylene, carbon tetrachloride, and benzene.
 - Do not attempt to clean the connector with anything metallic such as pins or paper clips.
 - Clean the connector only at a static-free workstation. Electrostatic discharge to the center pin of the connector will render the U8480 Series inoperative.
-

Clean the connector face by first using a blast of compressed air. If the compressed air fails to remove contaminants, use a foam swab dipped in isopropyl or ethyl alcohol. If the swab is too big, use a round wooden toothpick wrapped in a lint-free cloth dipped in isopropyl or ethyl alcohol.

THIS PAGE HAS BEEN INTENTIONALLY LEFT BLANK.

2 Performance Verification and Adjustments

Equipment List	20
Voltage Standing Wave Ratio (VSWR) Performance Verification	22
Power Linearity Performance Verification	24
Zero Set Performance Verification	27
Internal Calibration Performance Verification	29
Adjustments	31

This chapter contains the performance verification procedures which verify that the U8480 Series is operating within its published specifications. This chapter also provides information on adjustments performed after a performance verification fails.

NOTE

For valid performance verification, the following conditions must be met:

- The U8480 Series and test equipment must be allowed a 1-hour warm up period for all specifications.
- The ambient temperature must be within $25\text{ °C} \pm 10\text{ °C}$.

Equipment List

The following equipment are required for performance verification:

Equipment	Critical specification	Recommended Keysight model number/part number
Signal generator	Power range: -50 dBm to +20 dBm at 1 GHz Output resistance: 50 Ω	N5182A/E8257D/E8267D
Network analyzer	Frequency range: - 10 MHz to 120 GHz (dependent on DUT ^[a]) - 9 kHz to 6 GHz (for the Option 200)	E8361A/E8361C/E8363B/E8363C/ E8364B/E5071C/N5227B
Calibration kit	Frequency range: DC to 120 GHz (dependent on DUT)	85052B/85052C/85054A/85054B/ 85054D/85056A/85056D/85058B/ 85058E/85059B
Power splitter	Two-resistor type power splitter - N-type (f) - 3.5 mm (f) - 2.4 mm (f) Frequency range: DC to 67 GHz (dependent on DUT)	11667A/11667B/11667C/ 11667CH65
Power meter	Average power meter, compatible with 8480 Series and N8480 Series power sensors Absolute accuracy: $\pm 0.8\%$	N1913A/N1914A/E4416A/E4417A
Power sensor	Frequency: 10 MHz or above Power range: -30 dBm to +20 dBm Standing wave ratio (SWR): ≤ 1.15 at 50 MHz	N8481A/N8485A/N8487A/N8488A
Sensor cable	Sensor cable for the average power measurement	11730A

Equipment	Critical specification	Recommended Keysight model number/part number
Amplifier	Maximum output power: ≥ 30 dBm	–
Attenuator/switch driver	–	11713B
Attenuator	8494H: 0 to 11 dB programmable step attenuator, 0 to 18 GHz 8496H: 0 to 110 dB programmable step attenuator, 0 to 18 GHz 8491B: 10 dB coaxial fixed attenuator, DC to 18 GHz (N-type) 8493C: 10 dB coaxial fixed attenuator, DC to 26.5 GHz (3.5 mm)	8494H, 8496H, 8491B, 8493C
Connector	N-type (m)-to-3.5 mm (f) connector N-type (m)-to-2.4 mm (f) connector Characteristic impedance: 50 Ω	08485-60005 08487-60001
Computer	Desktop PC: 1.3 GHz Pentium® IV or higher recommended Laptop PC: 900 MHz Pentium® M or higher recommended RAM: 1.0 GB or higher Operating system: Windows® XP Professional Service Pack 2 or above (32-bit) Software: Keysight BenchVue Power Meter/Power Sensor Control & Analysis App and Keysight IO Libraries Suite 16.0 or above	–

[a] DUT stands for Device-Under-Test.

Voltage Standing Wave Ratio (VSWR) Performance Verification

VSWR is a measure of how efficiently RF power is transmitted from an RF power source. In real systems, mismatched impedances between the RF source and load can cause some of the power to be reflected back towards the source and vary the VSWR.

Procedure (DC to 10 MHz)

This performance verification requires the following equipment:

- network analyzer (E5071C)
 - mechanical calibration kit (85054B/D)
- 1** Turn on the network analyzer and allow it to warm up for approximately an hour.
 - 2** Set the start frequency of the network analyzer to 9 kHz and the stop frequency to 10 MHz (for the Option 200).
 - 3** Calibrate the network analyzer using the appropriate calibration kit. Perform calibration for the open, short, and load circuits of the network analyzer.
 - 4** After calibration, connect the U8480 Series to the test port of the network analyzer. Turn on **Correction** on the network analyzer to perform the VSWR measurement.
 - 5** Compare the measured results to the specifications in the datasheet. If the verification fails, refer to “Adjustments” on page 31.

Procedure (10 MHz to 120 GHz)

This performance verification requires the following equipment:

- network analyzer (E8361A/3B/4B/N5227B)
 - calibration kit (85054B/D, 85056A/D, 85058B/E, 85059B)
- 1** Turn on the network analyzer and allow it to warm up for approximately an hour.
 - 2** Set the start frequency of the network analyzer to 10 MHz and the stop frequency to 18 GHz (for the U8481A), 33 GHz (for the U8485A), 50 GHz (for the U8487A), 67 GHz (for the U8488A), or 120 GHz (for the U8489A).
 - 3** Calibrate the network analyzer using the appropriate calibration kit (85054B/D for the U8481A, 85052B/C for the U8485A, 85056A/D for the U8487A,

85058B/E for the U8488A, and 85059B for the U8489A). Perform calibration for the open, short, and load circuits of the network analyzer.

- 4 After calibration, connect the U8480 Series to the test port of the network analyzer. Turn on **Correction** on the network analyzer to perform the VSWR measurement.
- 5 Compare the measured results to the specifications in the datasheet. If the verification fails, refer to “Adjustments” on page 31.

Power Linearity Performance Verification

The power linearity performance verification measures the relative linearity error of the U8480 Series. All measurements are performed at 50 MHz. The reference power level for the linearity measurement is 0 dBm for the U8481A, U8485A, U8487A, U8488A, and U8489A.

This performance verification requires the following equipment:

- signal generator (N5182A)
- thermocouple-based average power sensor, as a reference sensor (N8481/85/87/88A)
- power meter (N1914A)
- power splitter (11667A/B/C)
- amplifier
- step attenuators (8494H and 8496H)
- attenuator/switch driver (11713B)
- computer, with the Keysight BenchVue Power Meter/Power Sensor Control & Analysis App and the Keysight IO Libraries Suite installed

NOTE

The linearity specification is calculated with a root sum of the squares (RSS) of the U8480 Series linearity specification and the reference power sensor linearity specification.

For example, at ranges -1 to 15 dBm:

The U8481A/8485A linearity specification is 0.50%.

The N8481A/N8485A reference sensor linearity specification is 0.52%.

Therefore, the linearity specification is equal to $\sqrt{(0.50^2 + 0.52^2)} = 0.7214$

Refer to the datasheet for the linearity specification at different ranges.

Procedure

- 1 Turn on the signal generator and power meter (with the reference sensor connected). Connect the DUT (U8480 Series) to the computer. Allow them to warm up for approximately an hour.
- 2 Zero and calibrate the DUT using the BenchVue Power Meter/Power Sensor Control & Analysis App and the reference sensor with the power meter.
- 3 Connect the power splitter to the RF output of the signal generator. The equipment setup is as shown below.

NOTE

For U8489A to connect to the power splitter, a 1.0 mm adapter is needed.

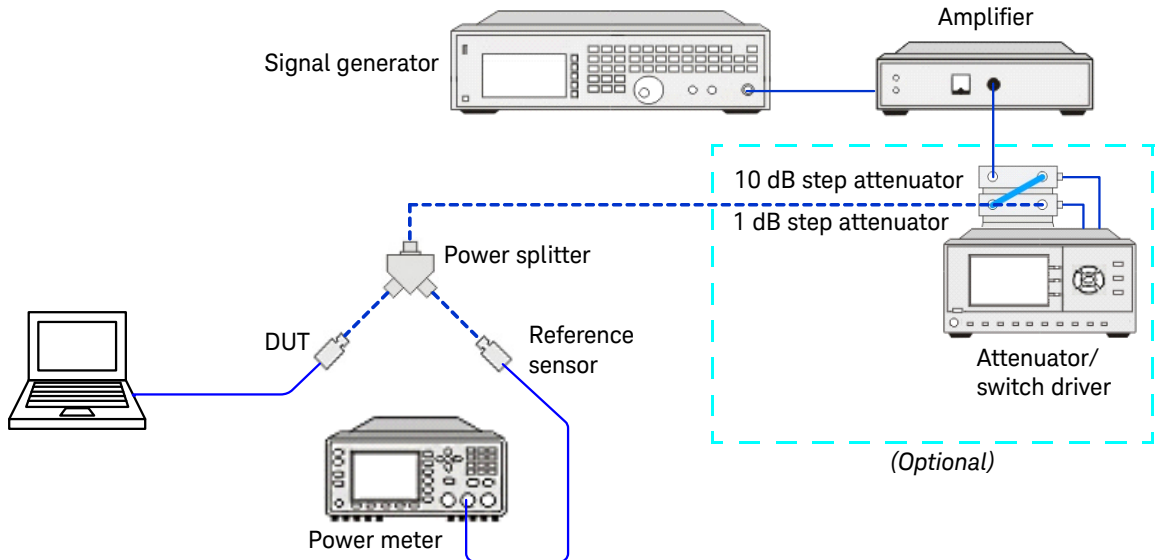

- 4 Set the continuous wave signal frequency of the signal generator, DUT, and reference sensor to 50 MHz.

- 5 Start tuning the signal generator and/or attenuator/switch driver (optional) until the DUT measures the power level as close as 0 dBm. Record the values as $P_{DUT \text{ at } 0 \text{ dBm}}$ and $P_{ref \text{ at } 0 \text{ dBm}}$.

CAUTION

Do not exceed the maximum input power (27 dBm) of the power splitter to avoid damage to the power splitter.

- 6 Record the power measured by the power meter as P_{ref} and the DUT power measured via the BenchVue Power Meter/Power Sensor Control & Analysis App as P_{DUT} .
- 7 Normalize both P_{ref} and P_{DUT} to the power measured at 0 dBm, based on the following equation:

Normalization

= Measured Power ($P_{DUT/ref}$) – Measured Power at 0 dBm ($P_{DUT/ref \text{ at } 0 \text{ dBm}}$)

- 8 Calculate the linearity error of the DUT for the power level using the following equation:

$$\text{Linearity error (dB)} = [P_{DUT}]_{\text{norm to } 0 \text{ dBm}} - [P_{ref}]_{\text{norm to } 0 \text{ dBm}}$$

$$\text{Linearity error (\%)} = \left[\text{Antilog} \left(\frac{[P_{DUT}]_{\text{norm to } 0 \text{ dBm}} - [P_{ref}]_{\text{norm to } 0 \text{ dBm}}}{10} \right) - 1 \right] \times 100$$

- 9 Compare the calculated linearity error to the root sum of the squares (RSS) of the U8480 series linearity specification and the reference power sensor linearity specification in the datasheet. If the verification fails, refer to “Adjustments” on page 31.
- 10 Repeat steps 6 to 9 by sweeping through the power levels from –1 dBm to 20 dBm with the same frequency of 50 MHz.
- 11 For the range of 16 to 20 dBm, add a 10 dB attenuator (8491B/8493C) before the reference sensor and repeat step 5 once. This is to ensure that the linearity specification of the reference sensor is within the range of –1 to <15 dBm instead of 15 to 20 dBm.

Zero Set Performance Verification

This performance verification is carried out to verify that a minimal amount of residual offset error is present after zeroing has been performed. The offset error is caused by contamination from several sources including the noise of the device-under-test (DUT) itself. Zero set is the difference between the power levels indicated by the DUT, after executing zeroing and the true zero power. Ideally, this difference should be zero.

This performance verification requires a computer with the Keysight IO Libraries Suite installed.

Procedure

- 1 Connect the DUT (U8480 Series) to the computer as shown in the following diagram. Then, launch the Keysight IO Libraries Suite on the computer.

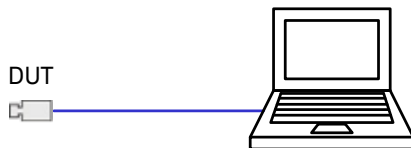

- 2 Warm up the DUT for approximately 1 hour to allow the temperature to settle.
- 3 Launch the Interactive IO on the Keysight IO Libraries Suite to send SCPI commands to the DUT.
- 4 Terminate the DUT with a load.^[1]
- 5 Perform zeroing for the DUT by sending “**CAL:ZERO:AUTO ONCE**”.
- 6 Perform internal calibration for the DUT by sending “**CAL:TYPE INT**” and “**CAL:AUTO ONCE**”.
- 7 Set the frequency of the DUT to 50 MHz by sending “**FREQ 50MHz**”.
- 8 Enable auto-averaging for the DUT by sending “**AVER:COUN:AUTO ON**”.

[1] Optional for all models except the U8488A.

2 Performance Verification and Adjustments

- 9** Change the power measurement unit of the DUT to watt by sending “**UNIT:POW W**”.
- 10** Set the DUT to the single trigger mode by sending “**INIT:CONT OFF**”.
- 11** Read the noise level of the DUT by sending “**READ?**” and then record the reading.
- 12** Repeat step **11** 10 times to record 10 values and find the mean value of the recorded 10 values.
- 13** Repeat steps **5** to **12** 10 times to find 10 mean values.
- 14** Calculate the final Zero Set value by finding the average mean value of the 10 mean values.
- 15** Compare the calculated final Zero Set value to the specification in the datasheet. If the verification fails, refer to “**Adjustments**” on page 31.

Internal Calibration Performance Verification

This performance verification is carried out to verify the accuracy of the U8480 Series internal calibration.

This performance verification requires the following equipment:

- power meter (N1914A)
- computer, with the BenchVue Power Meter/Power Sensor Control & Analysis App and the Keysight IO Libraries Suite installed

Procedure

- 1 Turn on the power meter, and connect the DUT (U8480 Series) to the computer.
- 2 Launch the Keysight IO Libraries Suite on the computer, and connect the DUT to the 1 mW reference calibration connector of the power meter. The equipment setup is as shown in the figure.

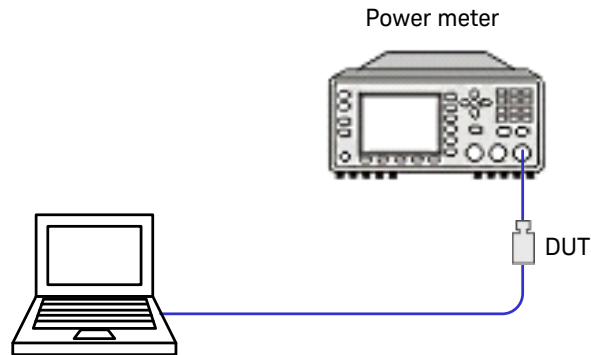

- 3 Perform internal calibration for the DUT by sending “**CAL : TYPE INT**” followed by “**CAL : ALL**”.
- 4 Change the power measurement unit of the DUT to watt by sending “**UNIT : POW W**”.
- 5 Turn on the 1 mW reference calibration source of the power meter, and then wait for 3 hours.
- 6 Set the DUT to the single trigger mode by sending “**INIT : CONT OFF**”.

2 Performance Verification and Adjustments

- 7** Read the power level of the DUT by sending “**READ?**”, and then record the reading.
- 8** Compare the reading to the specification in the datasheet. If the verification fails, repeat steps 3 to 7. If the verification fails for three times consecutively, refer to “**Adjustments**” on page 31.

Adjustments

Adjustments are usually required on a yearly basis. They are normally performed only after a performance verification has indicated that some parameters are out of specification. Performance verification must be completed after any repairs that may have altered the characteristics of the U8480 Series.

The U8480 Series is required to be returned to Keysight for adjustments. To arrange this, contact the Keysight Service Center. Refer to [“Sales and Technical Support”](#) on page 7.

THIS PAGE HAS BEEN INTENTIONALLY LEFT BLANK.

3 Theory of Operation

Theory of Operation 34

This chapter describes the operation and functions of the U8480 Series assembly.

Theory of Operation

The U8480 Series is an RF/ μ W power measurement device which is based on the thermocouple sensing element in order to provide a wider frequency range, and most importantly, higher accuracy and repeatability.

This new thermocouple-based USB power sensor is a combination of Keysight's traditional power meter and power sensor packaged in a smaller form factor. It offers the advantages of a USB power sensor in terms of connectivity, flexibility, form factor, and pricing along with the performance of a thermocouple power sensor.

As a thermocouple-based USB power sensor, the U8480 Series is able to perform a true average power measurement on both CW and modulated signals. It is a standalone power sensor which is capable of sensing, signal conditioning, acquiring, and processing the intended RF/ μ W signal for measurement.

The U8480 Series measurement functions and performance closely resemble Keysight's well-known N8480 Series power sensor connected to a power meter.

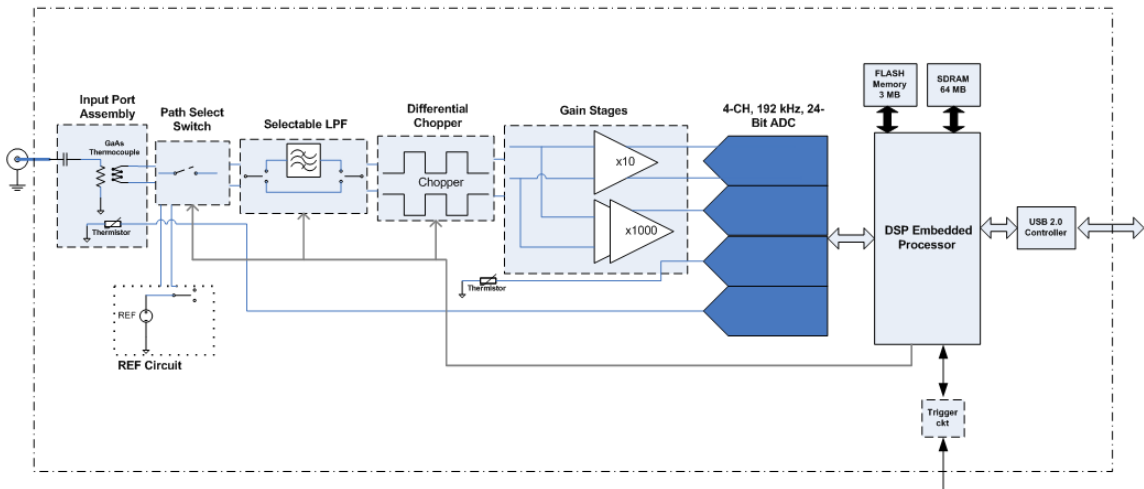

Figure 3-1 U8480 Series (AC-coupled) block diagram

Figure 3-1 illustrates the block diagram of the AC-coupled U8480 Series. The U8480 Series input consists of the bulkhead assembly which has a built-in GaAs thermocouple IC for optimum VSWR and isolation performance. The bulkhead assembly has embedded a thermistor for close temperature monitoring and a DC block for the standard model.

The heat generated by the RF/ μ W signal in the load termination of the thermocouple is converted to a differential signal by the thermopile which is then fed into a differential chopper, gain stages, and to a 4-channel 24-bit analog-to-digital converter (ADC) in the later processing stage.

The U8480 Series control and processing is provided by a DSP embedded processor which is supported by a 64 MB SDRAM. The available processing power enables the implementation of correction algorithm such as the linearity correction, calibration factor, and temperature compensation algorithm. The correction factors, firmware, and default settings for the U8480 Series are stored in the 3 MB non-volatile memory.

The U8480 Series is equipped with an internal calibration function which enables the U8480 Series to perform self-calibration without the need of the 1 mW 50 MHz reference calibrator. During the internal calibration process, the switch for path selection directs the analog circuitry to the on-board reference circuit. The reference circuitry provides a very accurate source that has negligible long term drift during the U8480 Series calibration cycle which is used to correct for analog circuitry drift and aging. The analog circuitry correction is combined with the linearity correction algorithm to achieve the internal calibration process. Internal calibration is allowable if there is RF input to the U8480 Series; it will not impact the U8480 Series performance.

The trigger input port which is based on TTL enables the U8480 Series to synchronize with events. Communications and remote control of the U8480 Series is via the Universal Serial Bus (USB) connectivity which is USB-TMC compliant.

THIS PAGE HAS BEEN INTENTIONALLY LEFT BLANK.

4 Repair Guide

Replaceable Parts 38

Disassembly/Reassembly Procedure 41

This chapter details the replaceable parts of the U8480 Series. It also explains how to assemble and disassemble the U8480 Series.

Replaceable Parts

NOTE

Replaceable parts are only available for the use of Keysight Service Center personnel and are not available for trade sales.

The following figure illustrates the parts breakdown of the U8480 Series which identifies all the replaceable parts. If you want to order a part, quote the Keysight

part number, specify the quantity required, and address the order to the nearest Keysight Sales and Service office.

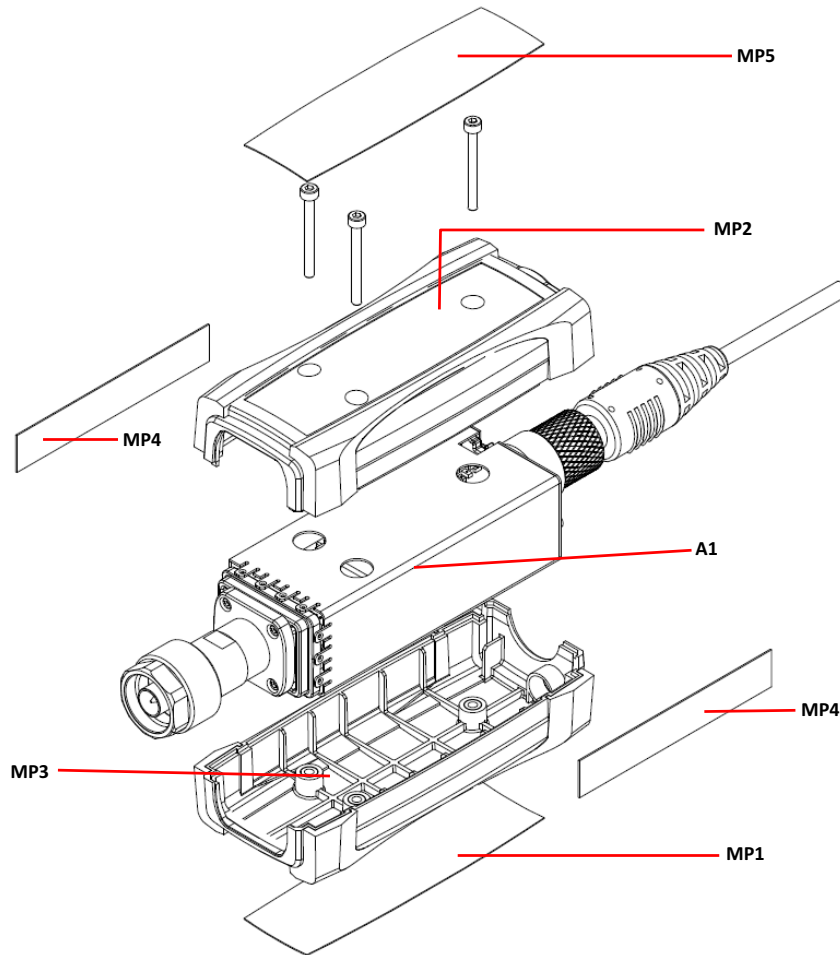

Figure 4-1 Illustrated parts breakdown

Table 4-1 Replaceable parts list for the U8480 Series

Reference designation	Option	Part number	Quantity	Description
A1				
U8481A	100	U8481-66001	1	U8481A replacement sensor module – AC-coupled
	200	U8481-66002	1	U8481A replacement sensor module – DC-coupled
U8485A	100	U8485-66001	1	U8485A replacement sensor module – AC-coupled
	200	U8485-66002	1	U8485A replacement sensor module – DC-coupled
U8487A	100	U8487-66001	1	U8487A replacement sensor module – AC-coupled
U8488A	100	U8488-66001	1	U8488A replacement sensor module – AC-coupled
Chassis part				
MP1	–	5190-0060	1	Bottom label
MP2	–	U2000-20001	1	Housing, top and overmold
MP3	–	U2000-20003	1	Housing, bottom and overmold
MP4	–	5190-0061	2	Middle label
MP5:				
U8481A	100	U8481-84302	1	Top label – AC-coupled
	200	U8481-84303	1	Top label – DC-coupled
U8485A	100	U8485-84301	1	Top label – AC-coupled
	200	U8485-84302	1	Top label – DC-coupled
U8487A	100	U8487-84301	1	Top label – AC-coupled
U8488A	100	U8488-84301	1	Top label – AC-coupled

Disassembly/Reassembly Procedure

CAUTION

Disassemble the U8480 Series only in a static-free workstation. Electrostatic discharge renders the U8480 Series inoperative.

Disassembly procedure

Use the following steps to disassemble the U8480 Series.

- 1 Remove the top label as shown below.



- 2 Loosen the three screws by using the M2 Torx screwdriver to remove the housing.



- 3 Replace the defective module with a new module.



Reassembly procedure

Tools required for reassembly

Tool	Purpose	Quantity	Torque value
M2 Torx screwdriver	To fit the housing	1	4.0 lbs. in.

Reassembly instructions

The reassembly procedure is simply the reversal of the disassembly procedure.

5 Contacting Keysight

Introduction	44
Returning the U8480 Series for Service	46

This chapter explains the appropriate actions to take if you have a problem with your U8480 Series.

Introduction

This section provides the information on what to do if you encounter problems with your U8480 Series.

If you wish to contact Keysight to enquire about the U8480 Series, from service problems to ordering information, refer to “[Sales and Technical Support](#)” on page 7.

If you wish to return the U8480 Series to Keysight, refer to “[Returning the U8480 Series for Service](#)” on page 46.

Instrument serial number

Keysight makes frequent improvements to its products to enhance their performance, usability, and reliability. Keysight service personnel have access to complete records of design changes for each instrument. The information is based on the serial number and option designation of each U8480 Series.

Whenever you contact Keysight about your U8480 Series, have a complete serial number available. This ensures you obtain the most complete and accurate service information. The serial number can be obtained from the serial number label.

The serial number label is attached to the side panel of the U8480 Series. This label has two instrument identification entries. The first provides the instrument serial number and the second provides the identification number for each option built into the instrument.

The serial number is divided into two parts: the prefix (two letters and the first four numbers), and the suffix (the last four numbers).

- The prefix letters indicate the country of manufacture. This code is based on the ISO international country code standard and is used to designate the specific country of manufacture for the individual product. The same product number could be manufactured in two different countries. In this case, the individual product serial numbers would reflect different country of manufacture codes. The prefix also consists of four numbers. This is a code identifying the date of the last major design change.

- The suffix indicates an alphanumeric code which is used to ensure unique identification of each product throughout Keysight.

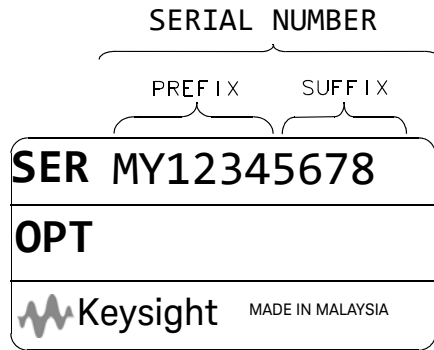

Figure 5-1 Serial number

Recommended calibration interval

Keysight recommends a one-year calibration cycle for the U8480 Series.

Returning the U8480 Series for Service

Use the information in this section if you need to return your U8480 Series to Keysight.

Packaging the U8480 Series for shipment

Use the following procedure to package the U8480 Series for shipment to Keysight for servicing:

- Be as specific as possible about the nature of the problem. Send a copy of any information on the performance of the U8480 Series.

CAUTION

Damage to the instrument can result from using packaging material other than those specified. Never use styrene pellets in any shape as packaging material. They do not adequately cushion the instrument nor prevent it from shifting in the carton. Styrene pellets cause instrument damage by generating static electricity and by getting lodged in the instrument panels.

- Use the original packaging material or a strong shipping container made of double-walled, corrugated cardboard with 91 kg (200 lb.) bursting strength. The carton must be large and strong enough to accommodate the U8480 Series and allow at least 3 to 4 inches on all sides of the U8480 Series for packing material.
- Surround the U8480 Series with at least 3 to 4 inches of packing material, or enough to prevent the U8480 Series from moving in the carton. If packing foam is not available, the best alternative is SD-240 Air Cap™ from Sealed Air Corporation (Commerce, CA 90001). Air Cap looks like a plastic sheet covered with 1-1/4 inch air-filled bubbles. Use the pink Air Cap to reduce static electricity. Wrap the U8480 Series several times in the material as protection and to prevent it from moving in the carton.
- Seal the shipping container securely with strong nylon adhesive tape.
- Mark the shipping container as “FRAGILE, HANDLE WITH CARE” to ensure careful handling.
- Retain copies of all shipping papers.



This information is subject to change without notice. Always refer to the Keysight website for the latest revision.

© Keysight Technologies 2013 - 2020
Edition 8, March 19, 2020

Printed in Malaysia



U8481-90004

www.keysight.com