

DL9040/DL9140/DL9240 Series Digital Oscilloscope

OPERATION GUIDE

Thank you for purchasing the DL9000 (DL9040/DL9040L/DL9140/DL9140L/DL9240/DL9240L) Digital Oscilloscope. This operation guide is designed to bring first-time users quickly up to speed with the basic operations of the DL9000. There are two other manuals for the DL9000 in addition to this operation guide: the DL9000 User's Manual (IM701310-01E) that explains all of the functions of the instrument, and the Communications Interface User's Manual (IM701310-17E, CD-ROM) that provides a more in-depth description of the instrument's communications functions. Please refer to all of these manuals when operating the instrument.

Note

- The contents of this manual are subject to change without prior notice as a result of improvements in the instrument's performance and functions. Display contents illustrated in this manual may differ slightly from what actually appears on the screen.
- Every effort has been made in the preparation of this manual to ensure the accuracy of its contents. However, should you have any questions or find any errors, please contact your nearest YOKOGAWA dealer.
- Copying or reproducing all or any part of the contents of this manual without the permission of Yokogawa Electric Corporation is strictly prohibited.

Trademarks

- Adobe, Acrobat, and PostScript are trademarks or registered trademarks of Adobe Systems Incorporated.
- The company and product names used in this manual are not accompanied by the trademark or registered trademark symbols (TM and ®).
- Other company and product names are trademarks or registered trademarks of their respective holders.

Revisions

1st Edition	June 2006
2nd Edition	June 2008
3rd Edition	April 2009

Contents

Flow of Operation	3
Names and Functions of Front Panel Controls	4
Parts of the Screen	7
Basic Key and Rotary Knob Operation	10
Introduction to Main Functions	12
Working with the DL9000	17
Preparing for an Observation.....	17
Displaying a Waveform on the Screen.....	19
Changing Waveform Display Conditions.....	20
Changing Trigger Settings	22
Measuring a Waveform	24
Zooming a Waveform.....	25
Printing and Saving a Waveform.....	26

Flow of Operation

The chart below is provided to give first-time users an easy-to-understand glimpse of the overall flow of the DL9000's operation. It is not intended to describe the flow of operations exactly as they are presented in this manual. For details about specific items introduced in the pages within, refer to the corresponding chapter or section in the user's manual as indicated by the arrows (▶).

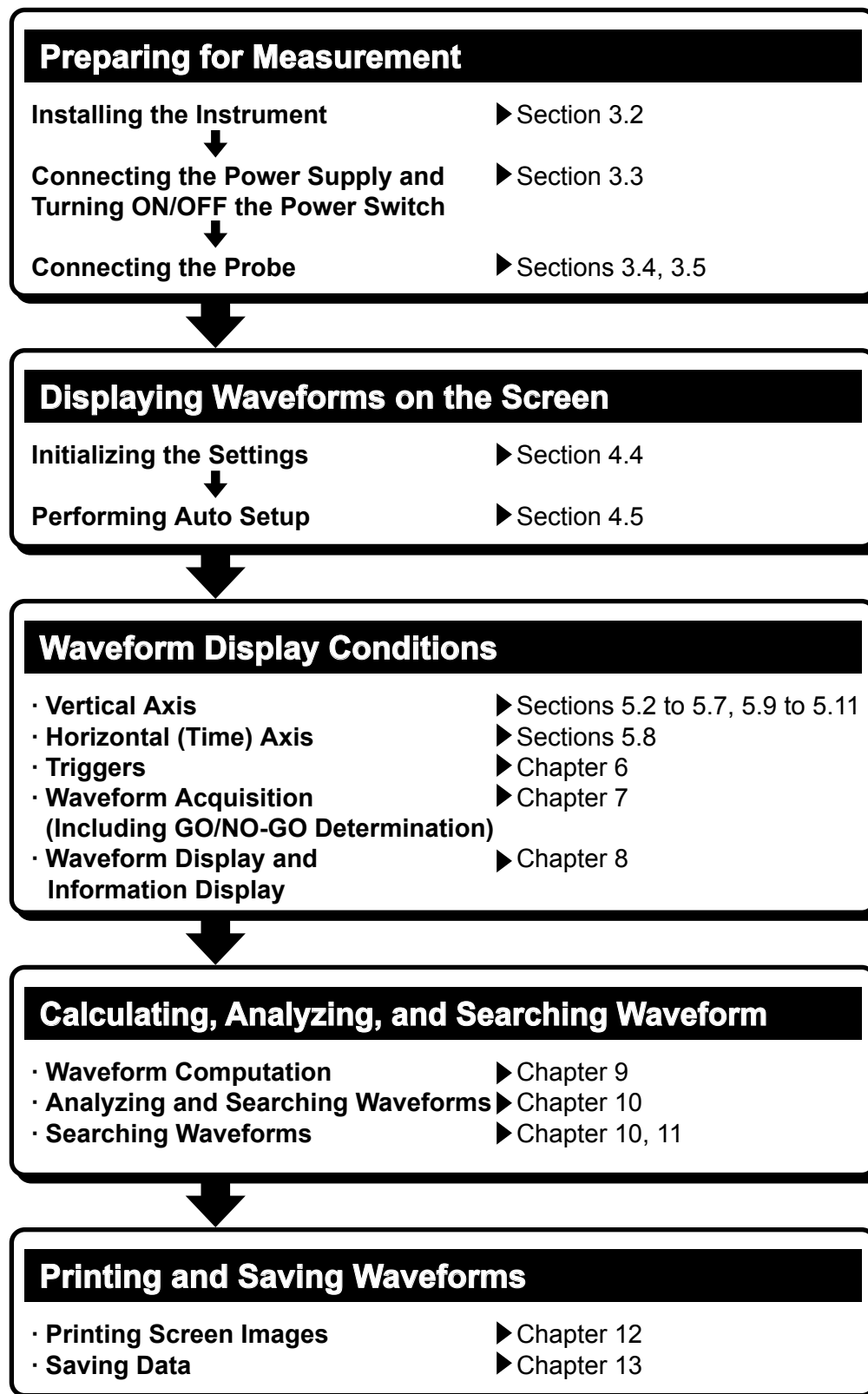

Names and Functions of Front Panel Controls

This section introduces the names of the various keys and knobs that appear on the front panel, and provides a brief explanation of what functions they control. For details about specific items introduced in the pages within, refer to the corresponding chapter or section in the user's manual as indicated by the arrows (▶).

Vertical Axis

CH1 to CH4 keys ▶ Chapter 5

These display menus for switching the display of each channel ON/OFF, coupling, probe type, offset voltage, bandwidth limit, expansion or reduction of the vertical axis, and waveform labels. Pressing one of these keys before using the V/DIV knob assigns the corresponding channel to the V/DIV knob operation. Each CH key lights when the corresponding channel is ON.

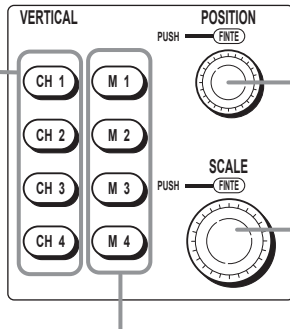

POSITION knob ▶ Section 5.3

When the voltage range is changed, you can change the center position. This knob includes a push switch, and can be pressed to change the resolution of the setting. Normal (Coarse) resolution is 1 div, and when pressed, lighting the Fine indicator, the resolution is 0.01 div.

SCALE knob ▶ Section 5.7

This sets the vertical axis sensitivity. Before turning this knob, press one of the CH1 to CH4, or M1 to M4 keys, to select the waveform adjusted. If you change this while waveform acquisition is stopped, the change takes effect when waveform acquisition is restarted. This knob includes a push switch, and can be pressed to change the resolution of the setting. When the knob is pressed, lighting the Fine indicator, the resolution is finer.

M1 to M4 keys ▶ Chapter 9, Chapter 14

These keys are used for waveform calculation settings, and settings relating to reference waveforms. Each key lights when the display is ON.

Horizontal Axis

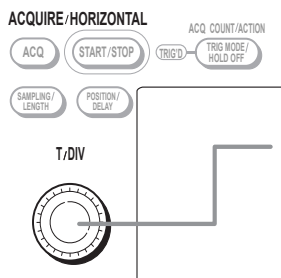

TIME/DIV knob ▶ Section 5.8

Sets the time axis scale. If you change this while waveform acquisition is stopped, the change takes effect when waveform acquisition is restarted.

Triggers

POSITION/DELAY key ▶ Sections 6.2, 6.3

Displays a menu for the trigger delay and trigger settings.

EDGE/STATE key ▶ Sections 6.6 to 6.9

Displays a menu for Edge/State trigger settings. Press one of four keys, including ENHANCED key, WIDTH key, and EVENT INTERVAL key, to select the trigger type. The pressed key lights, indicating that it is selected.

WIDTH key ▶ Sections 6.10 to 6.12

Sets the Width trigger.

SOURCE key ▶ Chapter 6

Displays a menu for setting trigger sources.

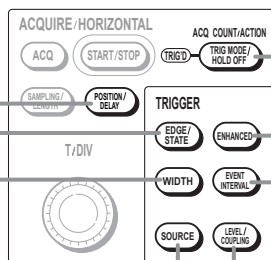

TRIG MODE/HOLD OFF ▶ Sections 6.1, 6.4, 7.1, 7.8

Displays a menu for selecting the trigger mode or hold off. Pressing the SHIFT key before pressing the MODE key displays the action on trigger menu.

ENHANCED key ▶ Sections 6.13 to 6.19

Displays a menu for TV trigger and serial trigger settings.

EVENT INTERVAL key ▶ Section 6.20

Displays a menu for event trigger settings.

LEVEL/COUPLING key ▶ Section 6.5

Displays a menu for trigger coupling, HF rejection, Window comparator, and other settings.

Acquisition

ACQ key ▶ Sections 7.1, 7.2

Displays a menu for setting the method of waveform acquisition.

SAMPLING/LENGTH key ▶ Sections 7.3 to 7.6

Displays a menu for setting record length, equivalent time sampling, interleave, and interpolation.

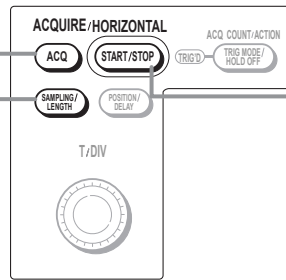

START/STOP key ▶ Section 4.7

Depending on the trigger mode, this starts/stops waveform acquisition. During waveform acquisition, the key lights.

Common Operations and Display, Analysis, and Searching

Arrow keys (▲ ▼ ◀ ▶ keys)

The left and right arrow keys move the digit cursor sideways when entering a numeric value. Use the up and down arrow keys to enter a numeric value.

SET key

Confirms a menu item selected with the rotary knob.

RESET key

Returns a numeric input value to its default.

Rotary knob

Used to change setup values and move the cursor

CURSOR key ▶ Section 10.1

Displays a menu for cursor measurement.

PARAM key ▶ Sections 10.2 to 10.3

Displays a menu for automatic waveform parameter measurement and statistics processing. Pressing the SHIFT key, followed by the PARAM key displays a menu for the telecom test.

WINDOW1 key and WINDOW2 key ▶ Sections 10.5 to 10.9

Display a menu for XY display, FPT analysis, waveform parameter histogram and list, and other settings. When the display is ON, the key lights.

FORM key ▶ Sections 8.2 to 8.5, 8.8

Displays a menu relating to screen display.

Numeric keypad

Use this for entering numeric values, file names, and so on.

SHIFT key

Pressing this once lights the indicator above the key, and enables the functions indicated on each key by a purple legend below the key. Pressing the key once more returns to the normal functions.

SETUP key ▶ Sections 4.4, 4.5

Displays a menu for the initialization function returning settings to their factory defaults, the auto setup function automatically setting values according to input signals, and for storing and recalling setting information.

HELP key

Turns the help window, which provides explanations of operations, ON and OFF.

(SHIFT+) HISTORY key ▶ Chapter 11

Displays a menu for displaying waveforms using the history memory function, and when searching. Pressing the SHIFT key, followed by the HISTORY key clears the displayed history waveform.

MAG knob ▶ Section 8.1

In a zoom display, turn this knob to change the zoom ratio on the applicable vertical/horizontal axis.

(SHIFT+) ZOOM1 and ZOOM2 keys ▶ Section 8.1

Display a menu for waveform zoom display and data search functions. Pressing the SHIFT key, followed by the ZOOM key displays a menu relating to zoom waveform positioning.

(SHIFT+) ACCUM key ▶ Section 7.7

Displays a menu for waveform overwriting display. Pressing the SHIFT key, followed by the ACCUM key clears the overwriting waveform.

Printing Screen Images and Saving/Loading Data



(SHIFT+) PRINT key ▶ Sections 12.2 to 12.4, 13.8

Prints the screen image data. Pressing the SHIFT key, followed by the PRINT key displays a menu when printing the screen image data to the internal printer or USB printer.



FILE key ▶ Sections 13.4 to 13.7, 13.9 to 13.12

Displays a menu for data saving and recall operations using a PC card or USB memory.



Calibration, Ethernet Communications, and Other Operations



SYSTEM key ▶ Sections 3.6, 4.8, 13.13, chapter 15, and 17
Displays a menu relating to calibration, network, computer interface settings, date and time, message language, click sound, self-test, and storage media formatting.
Displays system information (which options are installed, and firmware version).

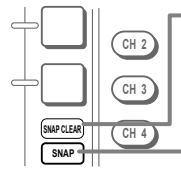

SNAP CLEAR key ▶ Section 8.7
Clears snap shot waveform.
SNAP key ▶ Section 8.7
Displays a non-updating copy of the currently displayed waveform on the screen in white.

Parts of the Screen

This section introduces the menus and symbols appearing on the DL9000 screen. For details about specific items introduced in the pages within, refer to the corresponding chapter or section in the user's manual as indicated by the arrows (▶ or ●●●▶ □).

Common Parts of the Screen

Waveform acquisition status
 Stopped : Stopped
 Running : Acquiring waveforms
 Pre... : Acquiring pre data
 Post... : Acquiring post data
 Waiting for Trigger : Waiting for Trigger

Waveform acquisition count

Date/time ▶ Section 3.6

Trigger position mark ▶ Section 6.2

Specified horizontal axis scale (time axis T/div) ▶ Section 5.8

Acquisition mode ▶ Section 7.1
 Normal : Normal mode
 Envelope : Envelope mode
 Average : Averaging mode

Displayed record length ▶ Appendix 1

Sample rate ▶ Appendix 1

Horizontal axis scale (time axis T/div) ▶ Section 5.8

Scale value ▶ Section 5.12

Label of the displayed waveform ▶ Section 8.6

Vertical position mark (-) ▶ Section 5.3

Ground level mark (≡) ▶ Section 2.3

Trigger level mark ▶ Section 2.4

Time from the trigger position to the left and right ends of the waveform area.

Setup menu

Trigger mode ▶ Sections 2.4, 6.2, 6.6 to 6.20

Trigger source, Polarity ▶ Section 2.4, chapter 6

Trigger level ▶ Section 2.4, chapter 6

Trigger coupling, HF rejection, Hysteresis ▶ Sections 2.4, 6.5

Input channel status
 Vertical axis settings of each channel

- Coupling ▶ Section 5.4
- Vertical axis Scale (Voltage sensitivity V/div) ▶ Section 5.7
- Probe attenuation ▶ Section 5.6

Computing/Reference waveform status

CH1 INPUT	CH2 INPUT	CH3 INPUT	CH4 INPUT	M1 MATH	M2 REF	M3 MATH	M4 MATH
DC Full	DC Full	DC Full	DC Full	Stuff Bit	Average	Through	Moving Avg
500mV/div	200mV/div	5.00 V/div	5.00 V/div	500m	200mV	5.00 V	5.00 V
10:1	1:1	1:1	1:1				

Screen When Displaying Zoomed Waveforms

●●●▶ User's manual section 8.1, "Zooming the Waveform"

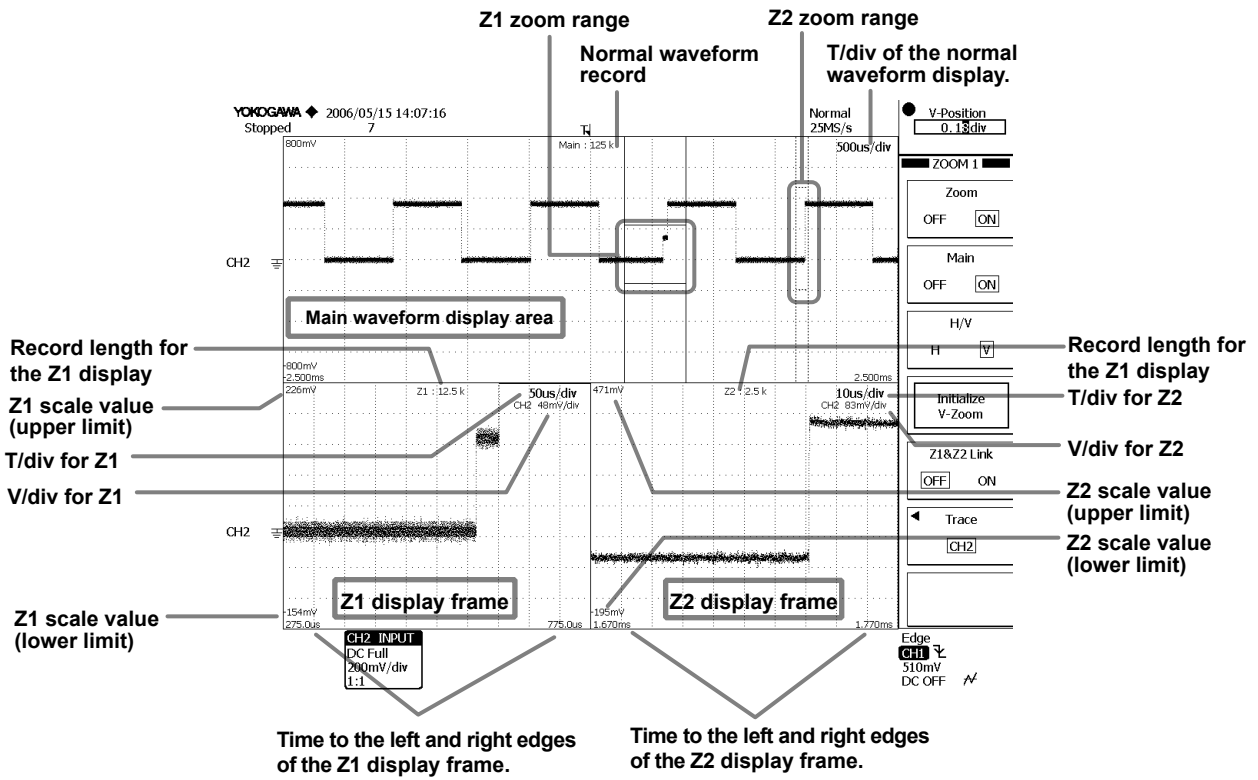

Screen When Displaying Logic Waveforms

- ● ● ▶ User's manual section 10.6, "Viewing the Phase between Measured Waveform on the XY Display"
- ● ● ▶ User's manual section 10.7, "Performing FFT Analysis"
- ● ● ▶ User's manual section 10.8, "Displaying a Histogram, Trend, or List of the Automatically Measured Waveform Parameters"
- ● ● ▶ User's manual section 10.9, "Displaying the Frequency Distribution of a Specified Area (Accum Histogram)"

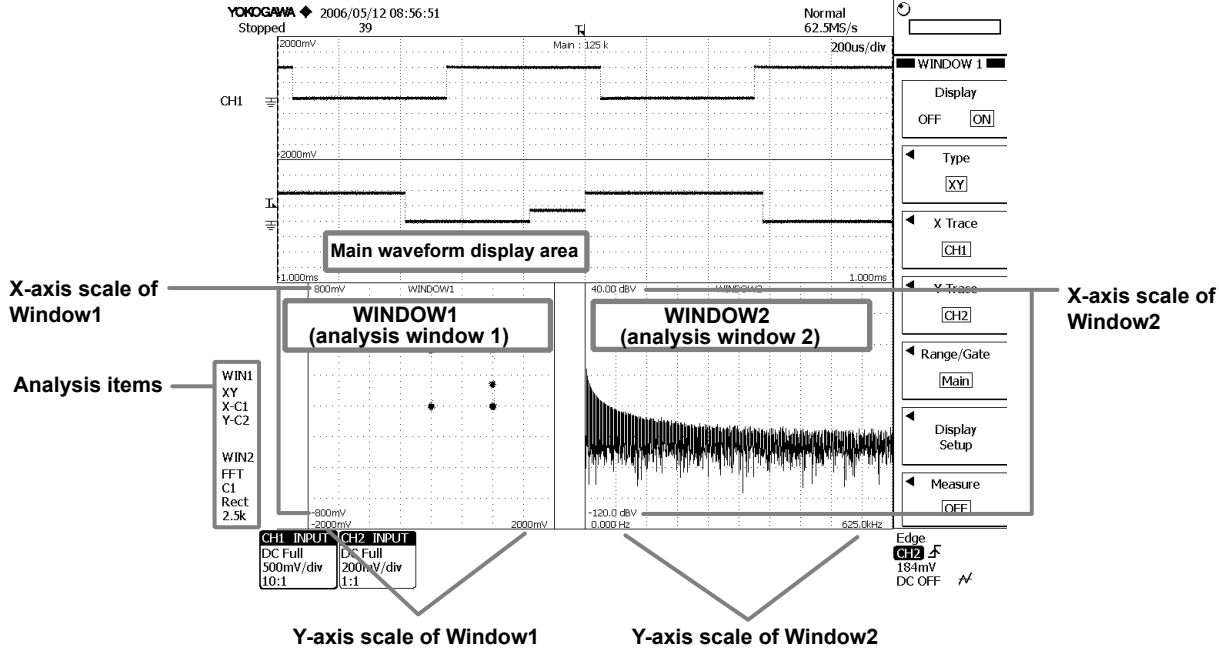

Basic Key and Rotary Knob Operation

This section describes key and rotary knob operations which are basic operations for setting the DL9000.

Basic Key Operations

Operations When a Setup Menu Is Displayed

ZOOM 1 Menu (Menu that appears when ZOOM 1 is pressed)

Setup menu

ESC key
Clears a setup menu or a setup dialog box.

Turn the rotary knob to change the setting.

A type of menu in which the item is selected from the displayed choices (ON or OFF in this case)
The selected item switches each time you press the soft key.
The selected item (ON in this example) is highlighted.

A type of menu in which a selection menu is opened for selecting items (with a ◀ mark)
Press the soft key to display the selection menu.
Press a soft key corresponding to the item you want to select.

A type of menu in which the item is selected using the rotary knob (with ● and ○ marks)
Press a soft key to select a menu you want to control using the rotary knob (● : selected, ○ : not selected).
Turn the rotary knob to change the setting.

Note
How to display the setup menu marked with purple characters on the front panel
Press the SHIFT key to illuminate the SHIFT key, and then press the key corresponding to the setup menu marked in purple.

Soft keys

Operations When a Setup Dialog Box Is Displayed

Waveform Parameter Setup Dialog Box

(When the Item soft key is pressed on the setup menu that appears when PARAM is pressed)

Setup dialog box

Use the rotary knob or arrow keys to select the item you want to set.

Press the SET key to select or deselect items.
A ✓ mark is displayed for the selected items.

(When these soft keys in the setup menu are pressed while the setup dialog box above is displayed: Area/Calc > Calc)

Press the SET key to open a box used to enter a value or characters.

Note

Press the ESC key to clear a setup menu or a setup dialog box from the screen.

Basic Rotary Knob Operation

Selecting an Item

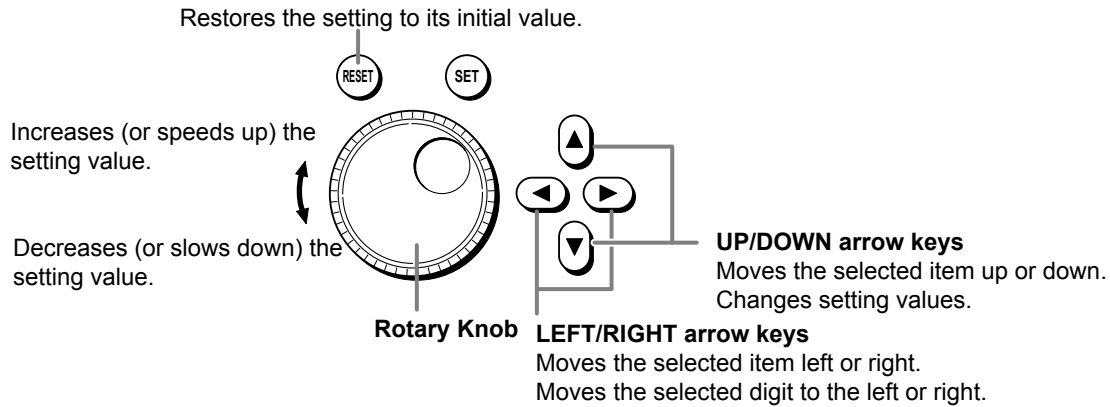

Tips

Using a USB Mouse

Introduction to main functions ●●●▶ □ User's manual section 4.3, "Using a USB Keyboard or USB"

If you connect a USB mouse to the USB PERIPHERAL connector on the front panel of the instrument, you can use the mouse to perform the same operations available with the front panel keys.

USB PERIPHERAL connector (front panel)

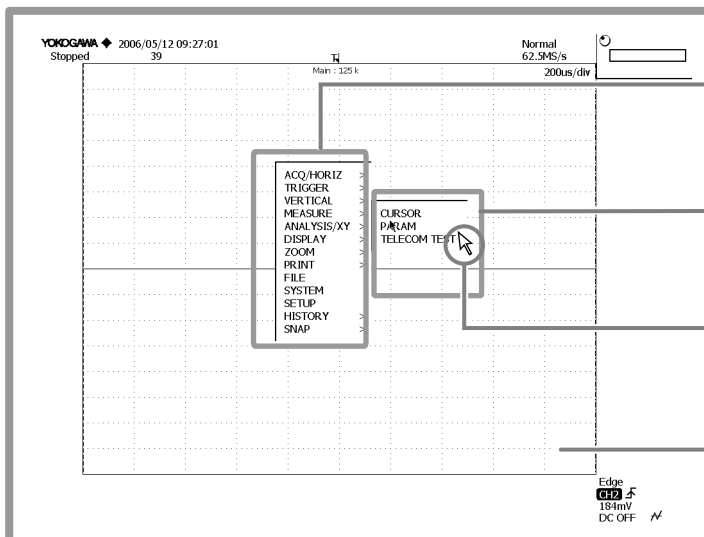
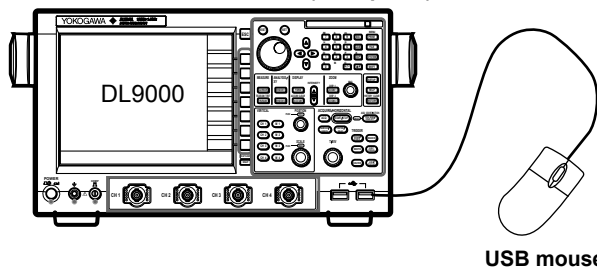

Top menu

Right click in the display (waveform display frame) to display the top menu containing all the names of the front panel keys.

Sub menu

A sub menu is displayed when clicking on a top menu item.

Pointer

Move the pointer to the desired item, click it, and the corresponding setup menu appears.

If you click outside of the menu, the previous setting menu is displayed.
If it is a top-level setting menu, the setting menu disappears.

Introduction to Main Functions

Trigger

● ● ● ►  User's manual chapter 6, "Triggers"

There are three main categories of triggers: Edge/State triggers, Width triggers and Enhanced triggers.

Edge/State Triggers

Edge Trigger

Trigger occurs on the edge (rising or falling) of a trigger source. You can select a trigger source* of measurement input signal, external trigger signal, or commercial power supplied from the instrument.

Edge(Qualified) Trigger

Trigger occurs on the edge of a single trigger source while each input signal's specified conditions are true.

Edge(OR) Trigger

Trigger occurs if the edge conditions of any one of the multiple trigger sources is true.

State Trigger

Trigger occurs when the logical (state) condition of the specified input signal is true, or stops being true. You can also have state conditions be judged on the edge of the specified input signal and triggers activated on the timing of the edge.

Width Triggers

Pulse Width Trigger

Trigger occurs depending on whether the conditions became true or not for a shorter or longer duration than a reference time specified in advance.

Pulse(Qualified) Trigger

Trigger occurs if the Pulse Width trigger conditions are true while the status of each input signal meets the specified conditions.

Pulse State Trigger

Trigger occurs when a relationship between the time in which the logical (state) condition of the specified input signal becomes true or not true, and a specified time, becomes true. You can also have state conditions be judged on the edge of the specified input signal and triggers activated on the timing of the edge.

Enhanced Triggers

TV Trigger

Trigger occurs on a video signal.

Serial Trigger**

Trigger occurs on the data pattern of a serial bus signal.

I²C Trigger**

Trigger occurs on the start condition of an I²C bus signal, address/data/pattern, Non-ACK, general call address, or start byte/high speed mode.

SPI Trigger**

Trigger occurs on a data or data pattern of an SPI bus signal.

CAN Trigger***

Trigger occurs on a pattern of the SOF, error frame, data frame/remote frame of a CAN bus signal.

LIN Trigger****

Trigger occurs on the data pattern of a LIN bus signal.

UART Trigger*****

Trigger occurs on the data pattern of a UART bus signal.

* A trigger source is a signal to which trigger activation conditions are applied.

** Supports software version 1.60 or later.

*** Supports software version 2.00 or later.

**** Supports software version 2.40 or later.

***** Supports software version 4.20 or later.

History Memory

● ● ● ►  User's manual Capture 11, "Displaying History Waveforms"

When measuring waveforms, numerical data is being loaded into the acquisition memory, and that data can be viewed on the DL9000 screen as a waveform. When taking continuous measurements, even if you stop measurement when you see an abnormal waveform, the waveform usually scrolls off the screen by the time measurement stops, preventing you from viewing it carefully. But with the history memory function, you can display past waveform data that has been loaded into the acquisition memory while measurement is stopped. Also, you can search for waveforms within the history waveforms that meet specified waveform conditions. The following 6 search conditions are available.

Conditions for searching for waveforms passing through (or not passing through) a specified search zone:

Waveform zone/rectangular zone/polygon waveform

Conditions for searching for waveforms that enter (or do not enter) a range of specified measured values.

Automatic measurement of waveform parameters/FFT-calculated values/XY waveform area

Searching the History Waveforms Using Rectangular Zone

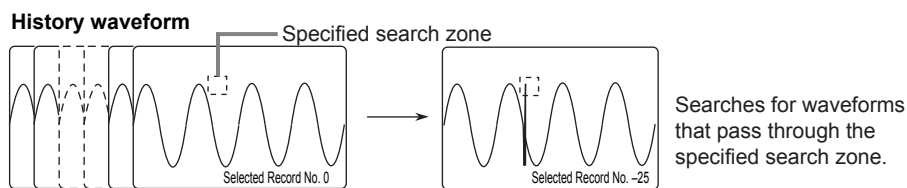

Zooming a Waveform

● ● ● ►  User's manual section 8.1, "Zooming the Waveform"

You can expand (zoom) a displayed waveform along the time axis or voltage axis. Two areas of a waveform can be zoomed at the same time. This function is useful when you want to observe one part of a waveform in detail that was acquired over a long period of time. You can specify the area to be zoomed or the zoom position (position of the zoom box).

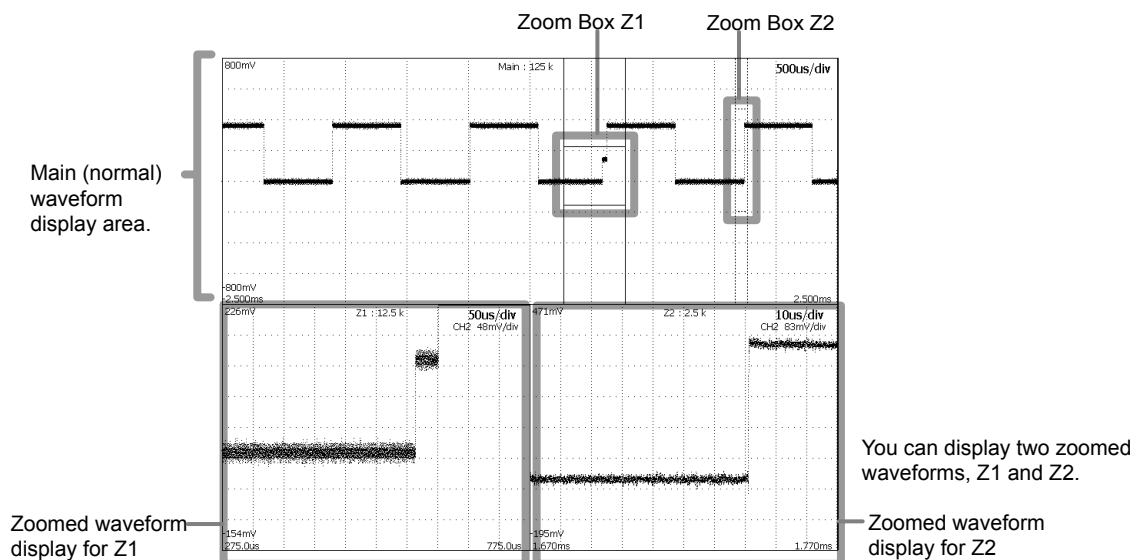

X-Y Waveform Display

● ● ● ►  User's manual section 10.6, "Viewing the Phase between Measured Waveform on the XY Display"

This function takes the signal level of the specified waveform assigned to the X-axis (horizontal axis), and the signal level of another waveform assigned to the Y-axis (waveform for which display is ON), and displays the relationship between the two. You can observe an X-Y waveform and the normal T-Y waveform (waveform based on the time axis and signal level) simultaneously. Up to two X-Y waveforms can be displayed on the screen.

Waveform Computation

● ● ● ►  User's manual chapter 9, "Computation"

The following operations are available: arithmetic (+, -, x), linear scaling, integration, phase shift, moving average(smoothing), IIR filter, edge count, and rotary count. A maximum of eight computed waveform can be displayed.

Reference Waveform

● ● ● ►  User's manual chapter 14, "Displaying Reference Waveforms"

Any of input waveforms, other computed waveforms, and previously stored input or computed waveforms can be selected for display.

You can also specify the reference waveform for waveform computation.

Displaying Accumulation

● ● ● ►  User's manual section 7.7, "Displaying Accumulation"

The display time of old waveforms can be set longer than the waveform update period, so that newer waveforms are superimposed (accumulated) on older waveforms. There are two modes, as follows:

Count

The specified number of waveforms are superimposed. A gradation is applied according to the data frequency.

Time

Waveforms for the specified time are superimposed. A gradation is applied from older data to new.

Cursor Measurements

● ● ● ►  User's manual section 10.1, "Making Cursor Measurements"

You can place cursors on a waveform to display the measured values at the points where the cursor intersects with the waveform. There are six types of cursor available: horizontal, vertical, H & V, VT, marker, and serial cursor.

Automatic Measurement of Waveform Parameters

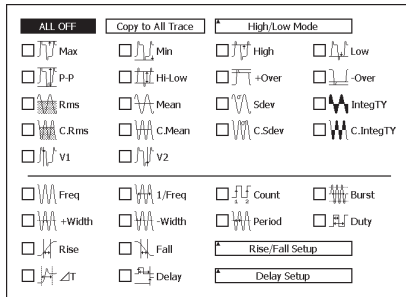

● ● ● ►  User's manual section 10.2, "Automated Measurement of Waveform Parameters"

This feature automatically measures parameters such as the maximum waveform level and frequency. It can measure 30 waveform parameters (including delay between channels) related to the voltage (vertical) axis, time (horizontal) axis, and waveform area.



- Up to 16 arbitrary parameters can be displayed.
- A total of up to 100000 data values can be stored for all waveforms.
- The measured values of waveform parameters can be used in computations.

Statistical Processing

● ● ● ►  User's manual section 10.3, "Performing Statistical Processing of the Measured Values of Waveform Parameters"
 ● ● ● ►  User's manual section 10.8, "Displaying a Histogram, Trend, or List of Automatically Measured Waveform Parameters"

The following five results of statistical processing are performed on the same two measured items from automatic measurement of waveform parameters.

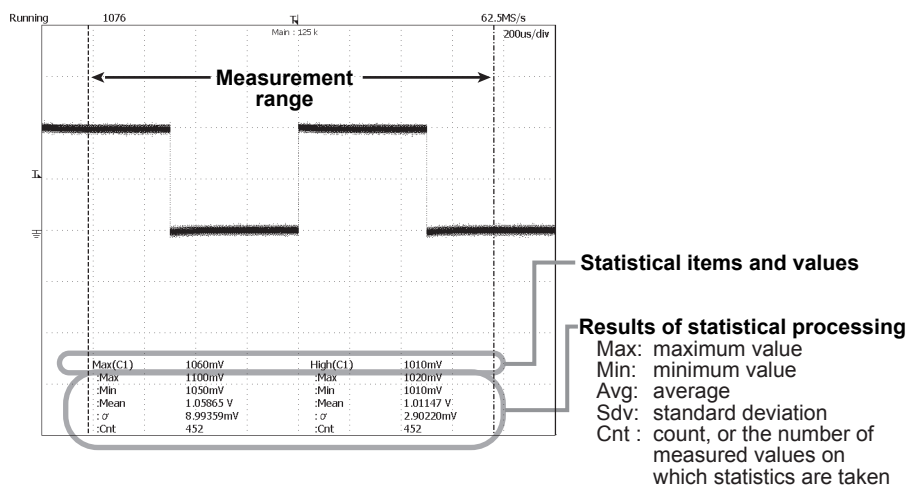

The following three types of statistical processing are available.

Normal measurement/statistical processing

During measurement, all waveform data acquired up to the current time are measured for the selected measurement item and statistics are calculated.

Measurement per cycle/statistical processing within the measurement range

Waveforms are delimited every cycle from the left side of the screen to the right (oldest to youngest), then each cycle is measured for the selected measurement item and statistics are calculated.

Measurement and statistical processing of history waveforms

History waveforms are measured for the selected measurement item, and statistics are calculated. Measurement and statistics are taken starting with the oldest waveforms.

You can also display the measured results in a list, trend, or histogram.

Snapshot

● ● ● ►  User's manual section 8.7, "Taking and Clearing Snapshots "

Using the Snapshot function, you can temporarily freeze a waveform on the screen that would ordinarily be lost when the screen is updated. Snapshot waveforms are displayed in white, allowing you to easily compare them with the updated waveforms. Furthermore, you can save snapshot waveforms to a memory medium, or print them out as screen images.

To delete a snapshot waveform, press the SNAP CLEAR key.

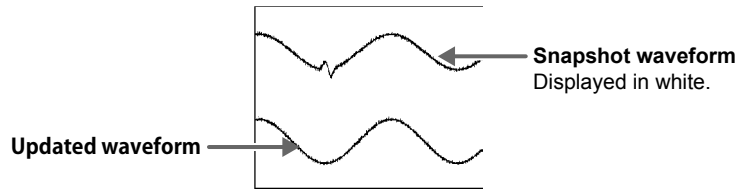

Telecom Test

● ● ● ►  User's manual section 10.4, "Telecom Testing "

There are two types: a mask test used for analyzing communication signals, and an eye pattern automatic measurement of waveform parameters test (the eye pattern automatic measurement of waveform parameters function applies to firmware version 1.60 or later).

When you turn ON telecom test, the accumulate display (Count mode) automatically appears.

With the mask test, mask patterns created using the free software available on the Yokogawa Web site are loaded onto the DL9000, and the waveforms that pass through the mask portion are counted.

Working with the DL9000

This section provides an example of how you can observe a probe compensation signal being output from the DL9000

Preparing for an Observation

Connecting the Power Supply

•••▶  User's manual section 3.3, "Connecting the Power"



Before connecting the power supply, you must read the warnings in the user's manual listed in section 3.3, "Connecting the Power."

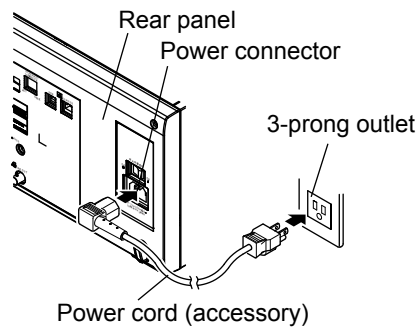

Rated supply voltage:	100 to 120 VAC/200 to 240 VAC
Permitted supply voltage range:	90 to 132 VAC/180 to 264 VAC
Rated power supply frequency:	50/60 Hz
Permitted power supply frequency range:	48 to 63Hz

Turning the Power Switch ON and OFF

•••▶  User's manual section 3.3, "Connecting the Power"



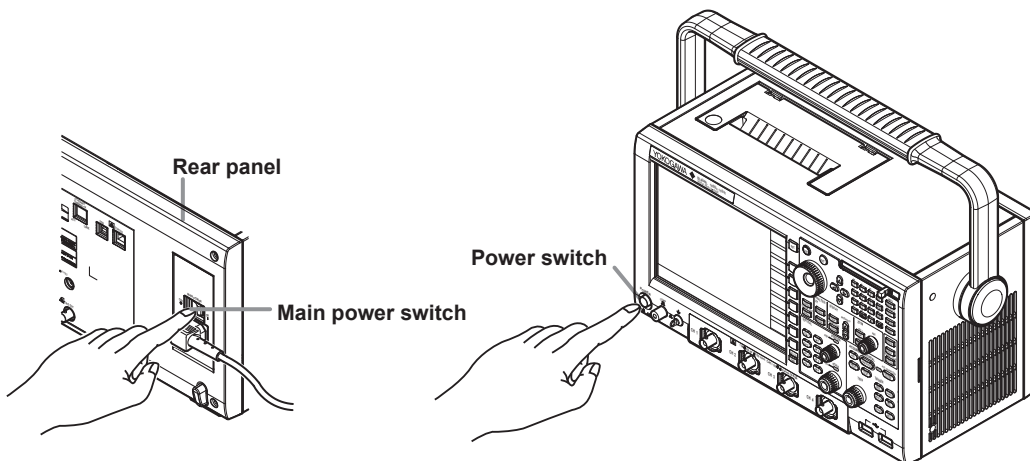

Before turning ON the main power switch, check that the power switch on the front panel is turned OFF.

First turn ON the main power switch on the rear panel, then turn ON the power switch on the front panel.



Connecting the Probe

- ● ● ▶  User's manual section 3.4, "Connecting the Probe"
- ● ● ▶  User's manual section 3.5, "Compensating the Probe (Phase Correction)"



Before connecting the probe, you must read the warnings in the user's manual listed in section 3.5, "Compensating the Probe (Phase Correction)."

Connect a probe to the DL9000's measurement input terminal (CH1).
Connect the tip of the probe to the probe compensation signal output terminal on the front panel of the DL9000.
Connect the probe's ground wire to the functional grounding terminal.

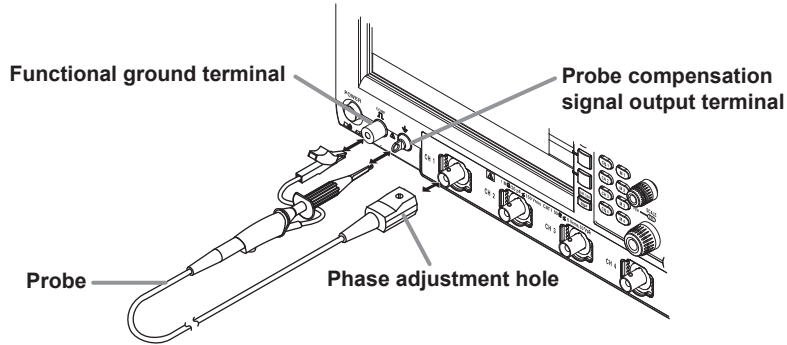

Note

- When actually making waveform observations using the probe, you must follow the procedures in the user's manual for probe phase correction (section 3.5), and calibration (section 4.8). Failure to use the probe correctly will result in incorrect waveforms.

Displaying a Waveform on the Screen

This section explains how to perform convenient, basic setting initialization and autsetup when you want to display common repeating waveforms such as sine waves and square waves.

Initializing Settings

●●●▶ User's manual section 4.4, "Initializing Settings"

The procedure below restores the settings that are controlled using the front panel keys to their factory default values. If this is your first time to use the instrument the procedure is not necessary, but performing the procedure now will help you remember it for future reference. This initialization procedure is also useful when reentering settings to match the input signal.

SETUP — 1 Press the SETUP key.

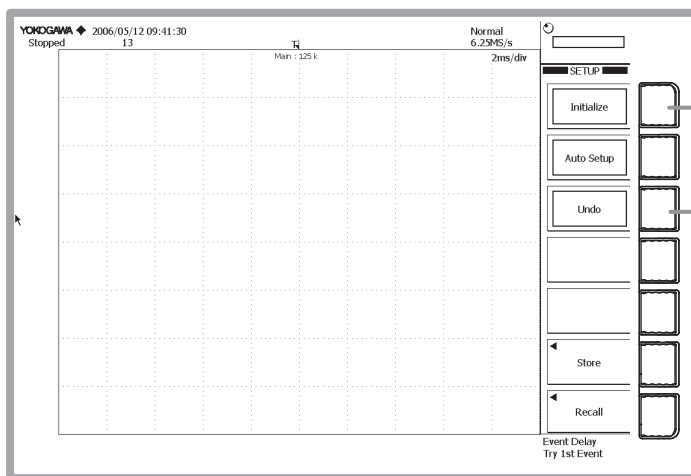

2 The initialization executes.

To restore the settings prior to initialization, press this button.

Note

- After initialization, display for all channels is turned ON, and the instrument enters START status.
- Items that cannot be initialized with the Initialize soft key are as follows:
Date/time setting, communication related settings, settings and waveform data stored in internal memory, and language settings.
To initialize all settings but the date/time setting and settings and waveform data stored in internal memory, perform the procedure below. Note that settings cannot be restored after this procedure.
Turn the power switch to the DL9000 ON while pressing the RESET key.

Auto Setup

●●●▶ User's manual section 4.5, "Performing Auto Setup"

You can automatically enter vertical axis, horizontal axis, and trigger settings according to the input signal. This function is useful when you just want to quickly display the signal in order to determine what kind of signal it is and what sort of settings might be required to measure it.

SETUP — 1 Press the SETUP key.

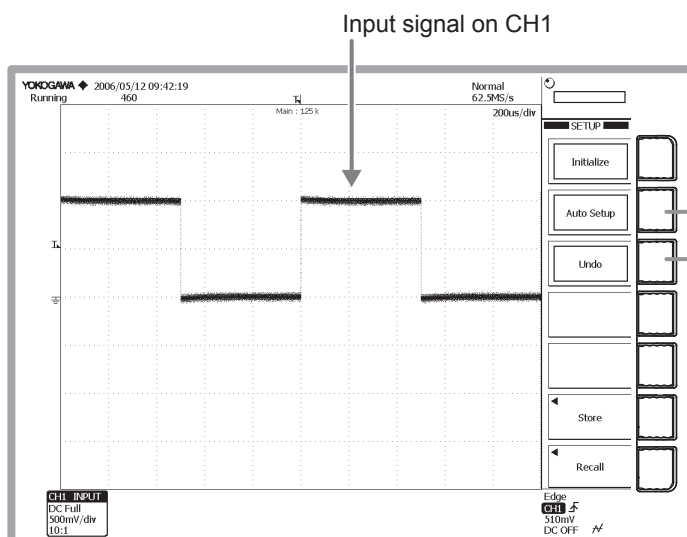

2 Auto setup executes.

To restore the settings prior to auto setup, press this soft key.

Note

- When you execute auto setup, only the display of the channel on which the signal is being input is ON.
- The waveforms on which auto setup can be performed must have the following properties:
Frequency: approximately 50 Hz or higher
Absolute value of input voltage: max. value of 20 mV (1:1) or more
Type: repeating wave (non-complex)

Changing Waveform Display Conditions

This section explains how to split the screen, and how to change settings such as the voltage or vertical axis sensitivity and vertical position, or the time or horizontal axis.

Changing the Voltage Axis Sensitivity Setting from 500 mV/div to 200 mV/div

●●●▶ User's manual section 5.7, "Setting the Scale"

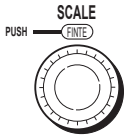

1 Turn the T/div knob clockwise to set the voltage axis sensitivity to 200mV/div.

One part of the waveform goes out of view due to the rise in the voltage axis sensitivity.

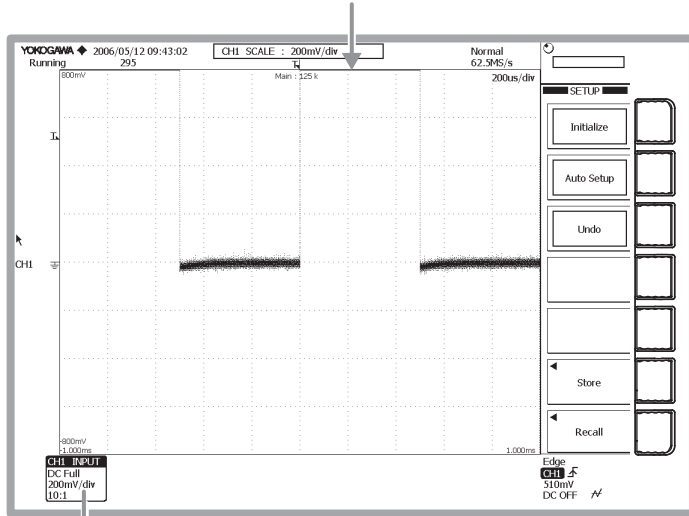

The voltage axis sensitivity setting for CH1

Note

When displaying multiple waveforms, press the key to target CH1 for the SCALE knob.

Bringing the Waveform's Entire Amplitude into View by Lowering the Vertical Position

●●●▶ User's manual section 5.3, "Setting the Vertical Position of the Waveform"

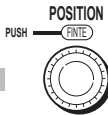

1 Turn the POSITION knob counterclockwise to set Position to -2.00 div.

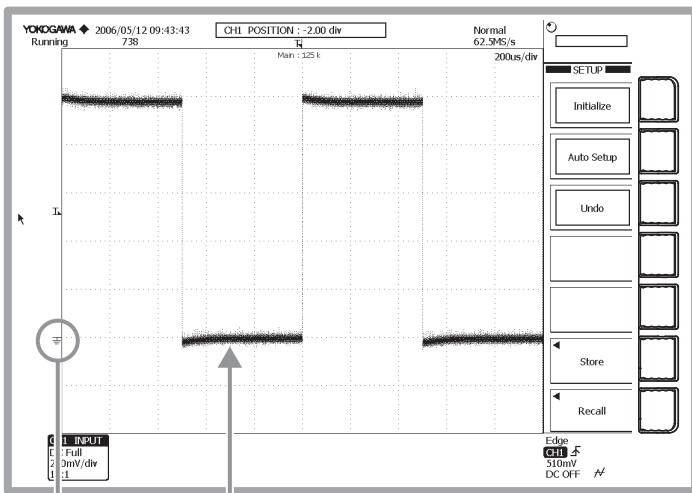

Lowering the vertical position allows the entire amplitude of the waveform to be displayed. The ground level mark is also moved.

Note

When displaying multiple waveforms, press the key to target CH1 for the POSITION knob.

Changing the Time Axis Setting from 200 μ s/div to 100 ms/div

● ● ● ► User's manual section 5.8, "Setting Time Axis (T/div)"

The time axis setting is the setting for the amount of time per grid division. If you lower the speed (increase the value) of the time axis setting when in Auto or Auto Level trigger mode, the display mode changes from Update Mode (in which the displayed waveform updates) to Roll Mode (in which the waveform scroll across the screen from right to left). Roll mode is useful when you want to observe signals with long periods or signals that change slowly.

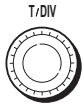

1 Turn the T/DIV knob counterclockwise to set the time axis setting to 100 ms/div

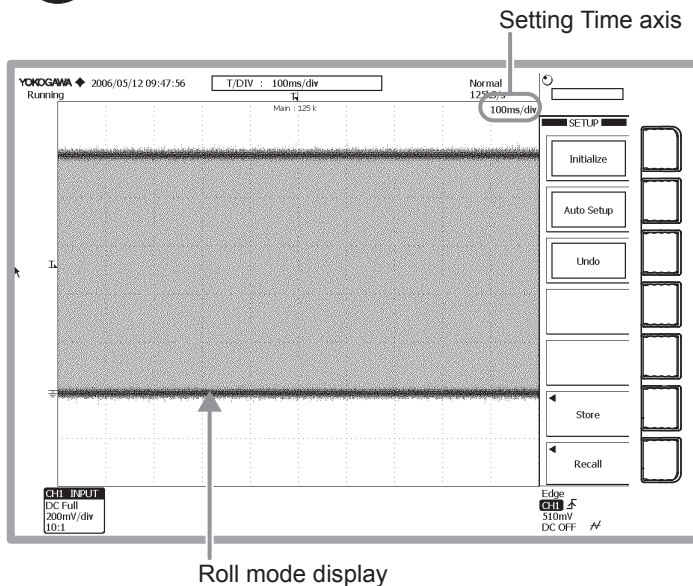

Changing the Time Axis Setting from 100 ms/div to 500 μ s/div

● ● ● ► User's manual section 5.8, "Setting Time Axis (T/div)"

The display reverts from roll mode back to update mode, and five periods worth of the waveform is displayed.

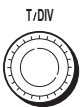

1 Turn the T/DIV knob clockwise to set the time axis setting to 500 μ s/div.

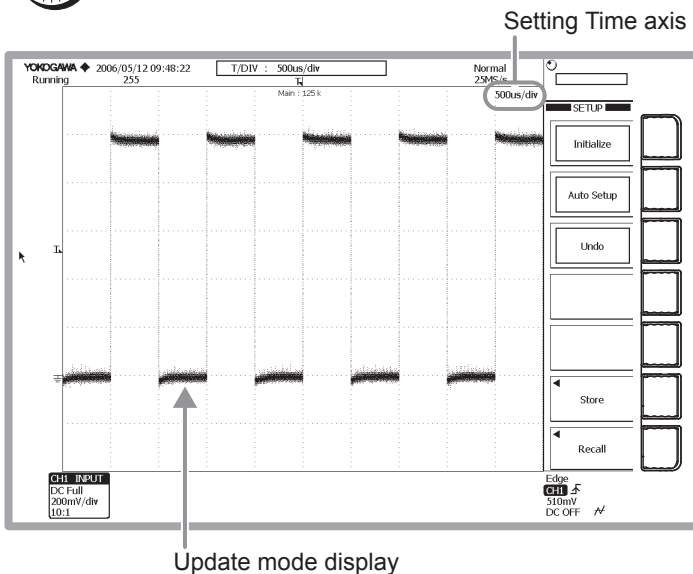

Changing Trigger Settings

Trigger settings determine which waveforms of the loaded measurement signals to display, and at which times. The following are the most commonly used trigger settings.

Trigger Types

The three main types of triggers are edge/state triggers, width triggers, and enhanced triggers. For details, see page 12 of this guide.

Trigger Source

A trigger source is a signal to which trigger activation conditions are applied.

Trigger Slope

The slope of a signal is its movement from a low level to a high level (rising), or from a high level to a low level (falling). When specifying the slope as one of the trigger conditions, it is called the trigger slope. The point at which the slope of the trigger source passes through the trigger level is called the edge.

Trigger Level

Trigger level refers to a given level at which a trigger is activated when the trigger source passes this level. With simple triggers such as the edge trigger (see page 12 in this operation guide), a trigger is activated when the trigger source level passes through a specified trigger level.

Trigger Mode

The trigger mode determines the conditions (such as timing and the number of times) at which the waveform display is updated. If you execute auto setup, the trigger mode is set to auto mode. Five trigger modes are available. For details, see section 6.1 of the user's manual, "Selecting the Trigger Mode."

Trigger Position

When waveform acquisition is started, triggers are activated according to the trigger conditions, and the waveforms loaded into acquisition memory are displayed. By moving the trigger position on the screen, you can change the ratio of data that is displayed before (pre data) and after (post data) the trigger was activated. The initial setting is 50.0% (center screen).

Window Comparator

Judges the condition based on whether the measured values of each channel are inside or outside of the specified area. For example, when the Window comparator for the trigger source is turned ON, you can activate a trigger based on whether the trigger source is inside or outside of a specified range.

If you initialize the settings or execute auto setup, the trigger type is set to edge/state (trigger source: CH1, edge trigger). Edge triggers activate based on the rising, falling, or both, of one input signal. In the procedure below, the trigger type is left as-is (edge trigger), and the method for changing the trigger slope, trigger mode, and trigger position settings is explained.

Changing the Trigger Slope from Rising to Falling

● ● ● ▶ User's manual section 6.7, "Activating an Edge Trigger (Edge/State)"

1 Press the SOURCE key.

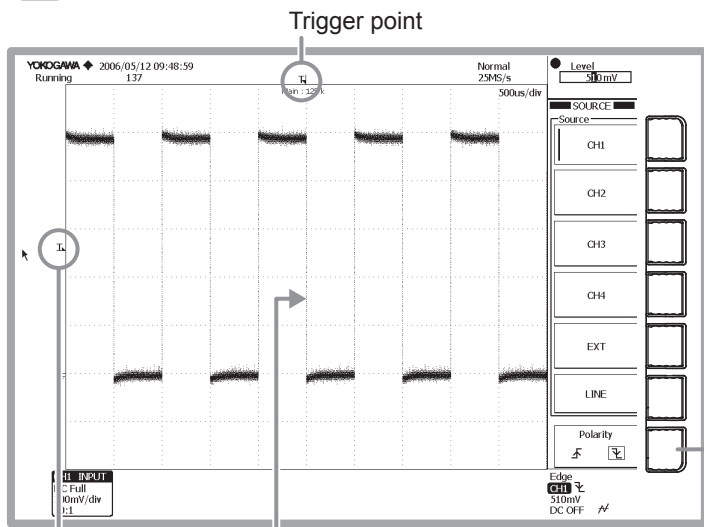

2 Press the soft key to select ∇ (Falling).

Note

- Confirm that the Edge/State key is lit.
- The menu that appears when pressing the SOURCE key differs depending on the trigger type.

Shifting the Trigger Position to the Left by Two Divisions

●●●▶ User's manual section 6.2, "Setting the Trigger Position"

By shifting the waveform to the left by just 2 div, the part of the waveform after the trigger (post trigger) becomes much easier to see.

1 Press the POSITION/DELAY key.

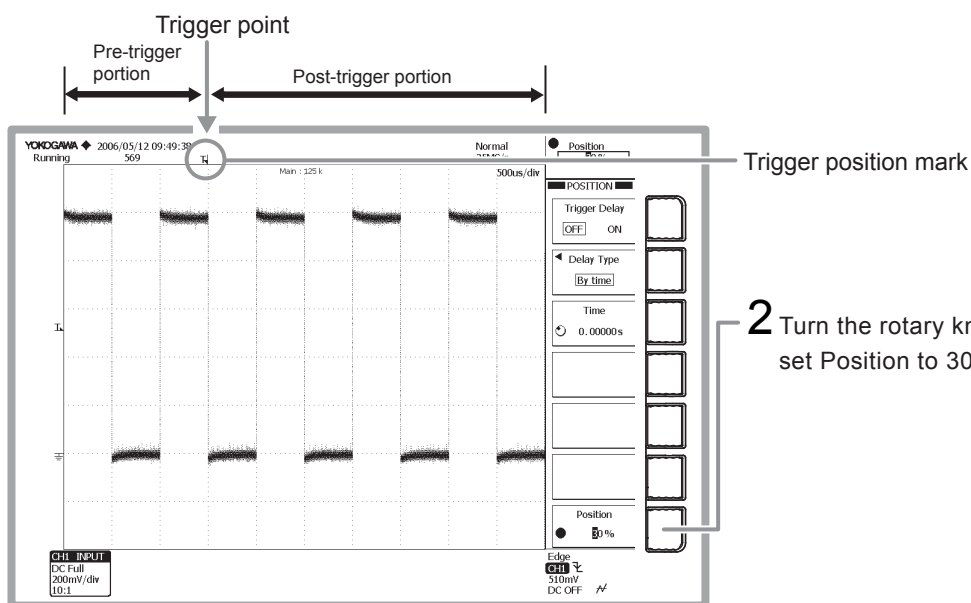

2 Turn the rotary knob counterclockwise to set Position to 30%.

Changing the Trigger Mode from Auto to Single

●●●▶ User's manual section 6.1, "Setting the Trigger Mode"

When a trigger activates in Single mode, the waveform display update stops once, and waveform acquisition stops. Single mode is useful for observing single-shot waveforms.

ACQ COUNT/ACTION

1 Press the TRIG MODE/HOLD OFF key.

When waveform acquisition stops, the status changes from "Running" to "Stopped."

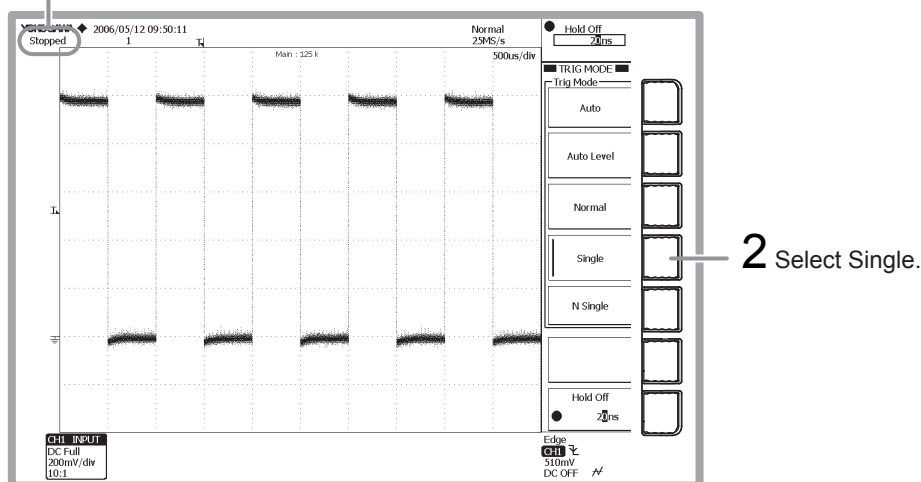

Measuring a Waveform

This section explains how to use the vertical cursors to measure the voltage and period of the displayed waveform. In addition to cursor measurement, the DL9000 also has functions such as automatic measurement of waveform parameters and computation functions that are useful for taking pulse waveform and other types of measurements.

Measuring Voltage with Vertical Cursors

●●●▶ User's manual section 10.1, "Making Cursor Measurements"

The voltage (Y-axis) and time (X-axis) at the position of the cursor is displayed in the lower part of the waveform display frame.

CURSOR — 1 Press the CURSOR key.

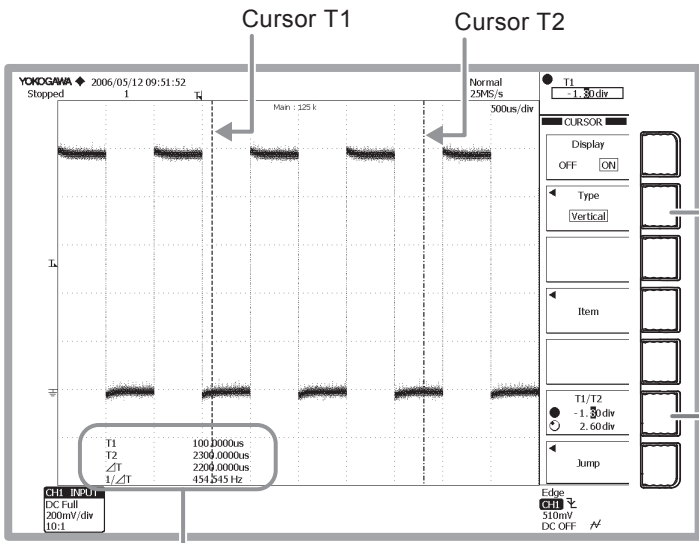

2 Open the selection menu, then choose Vertical.

3 Activate the rotary knob on Cursor T1.

4 Turn the rotary knob to move Cursor T1.

5 Move Cursor2 in the same manner.
If you activate the rotary knob on both Cursor T1 and Cursor T2, you can move both cursors at the same time.

- T1 : X-axis value of Cursor T1
- T2 : X-axis value of Cursor T2
- ΔT : difference in X-axis values of Cursor T1 and Cursor T2
- 1/ΔT : reciprocal of the difference in the X-axis values of Cursor T1 and Cursor T2

Note

Cursor Types

Horizontal cursor	Measures the Y-axis value at the cursor position.
Vertical cursor	Measures the X-axis values at the cursor position.
H & V cursor	Measures the X and Y-axis values at the cursor position.
Marker cursor	Measures the X and Y-axis values of the waveform. The marker cursor moves along the waveform. M1 to M4 (markers 1 through 4) can be set on separate waveforms.
VT cursor	Measures the time from the trigger position to the cursor position, and the Y-axis value at the cursor position of each waveform.
Serial cursor	Using a specified level as a reference, displays the Y-axis value at the cursor position as either 0 or 1. You can set the bit rate and the number of displayed bits.

Zooming a Waveform

This section describes how to zoom a portion of the displayed waveform. You can zoom along the vertical or horizontal axes.

Setting the Horizontal Axis Zoom Factor

●●●▶ User's manual section 8.1, "Zooming the Waveform"

You can display two zoomed waveform portions of the original (normal) waveform. The portion of the original waveform that is zoomed is shown by the "zoom box."

— 1 Press the ZOOM1 or ZOOM2 key.

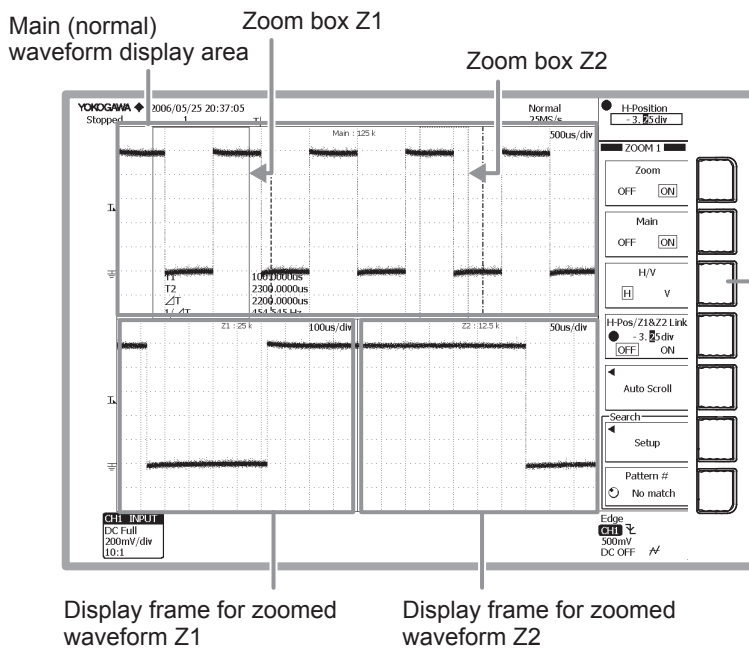

- 2 Select H for the zoom direction
- 3 Turn the MAG knob to set the zoom factor.

Moving the Zoom Position Horizontally

●●●▶ User's manual section 8.1, "Zooming the Waveform"

You can move the zoom position while watching the zoom box.

— 1 Press the ZOOM1 or ZOOM2 key.

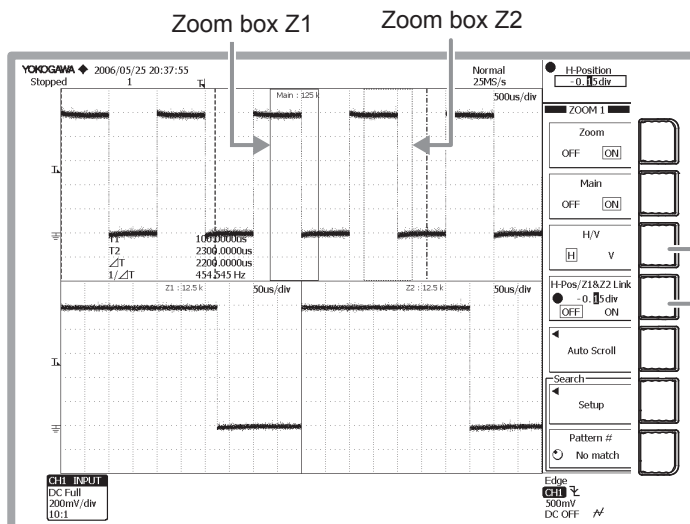

- 2 Select H for the zoom direction.
- 3 Turn OFF the Z1 and Z2 zoom box link.
- 4 Move the zoom box horizontally with the rotary knob.

Note

If you turn Z1&Z2 LINK ON, you can move zoom boxes Z1 and Z2 simultaneously.

Printing and Saving a Waveform

This section describes how to print out the displayed waveform on the built-in printer (when the /B5 option is installed) or save it to a storage medium. You can also print waveforms to a USB printer.

And you can also save to the flash ATA card (PC card TYPE II) or the compact flash (using the PC card TYPE II adapter) using the installed PC card interface. You can also save to the network drive (with the /C8 or /C10 option installed).

Printing Screen Images on the Built-In Printer

●●●▶ User's manual section 12.2, "Printing Using the Built-In Printer (Optional)"

You can print the waveform exactly as it appears on screen. Before printing, follow the procedure in section 12.1 of the user's manual to load roll paper into the built-in printer.

PRINT — 1 Press the PRINT key. Printing starts.

Example of a Printout

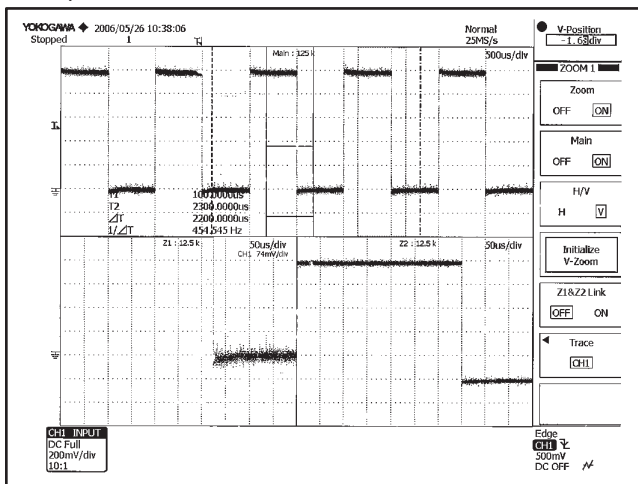

Note

If you press the PRINT key after the SHIFT key, the PRINT menu appears. Settings using this menu are not required by this operation guide, but it may be useful to know that you can specify the print destination (built-in printer, USB printer, or file) or others.

PRINT Menu

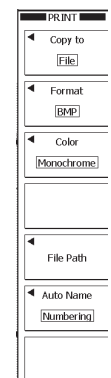

Saving Screen Image Data to a Storage Medium

●●●▶ User's manual section 13.8, "Saving Screen Image Data"

You can save the waveform displayed on screen to a storage medium as image data.

SHIFT + **PRINT** — 1 Press the SHIFT key (the SHIFT key lights), then press the PRINT key.

PRINT — 7 Press the PRINT key again. The image is saved.

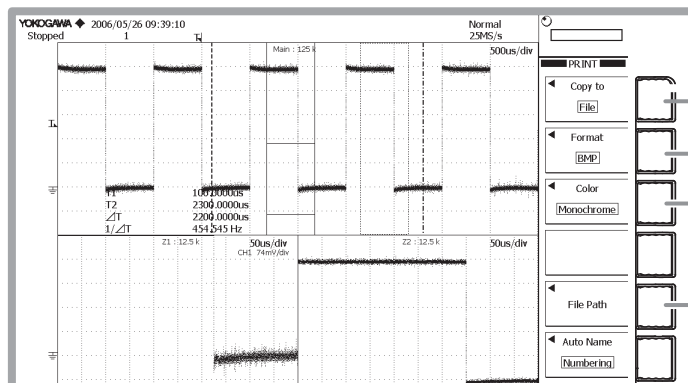

- 2 Select File
- 3 Select a data format
- 4 Select a color mode.
- 5 Select a save destination medium.

- [network] :Network drive (optional)
- [Flash Mem] :Internal memory
- [HD] :Internal hard disk (optional)
- [USB storage] :USB storage
- [Storage Card] :PC card

Media Name	Free Size	Total Size
Network		
Flash Mem	1.70MB	15.1MB
HD	27.9GB	27.9GB
USB Storage	496MB	497MB

Drive name

6 Press the Open soft key to display a file list of the selected media.

Saving Waveform Data to a Storage Medium

● ● ● ▶ User's manual section 13.5, "Saving/Loading the Measurement Data"

You can save the waveform data displayed on screen to a storage medium. When the waveform is saved, its vertical axis, horizontal axis, and trigger settings are also saved.

During a save, the media access icon is displayed at the lower left of the screen.

FILE — **1** Press the FILE key.

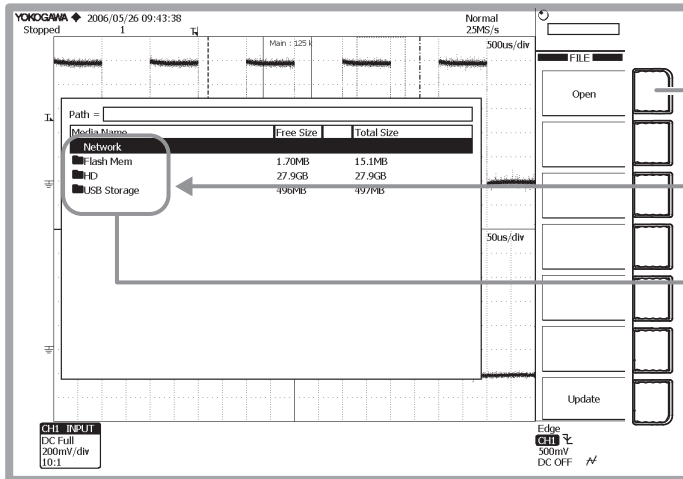

3 Display the File List.

2 Turn the rotary knob to select a save medium.

Drive name of the storage medium
See previous page.

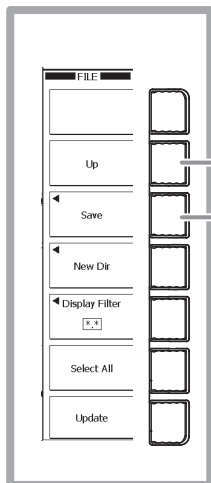

Moves one directory up

4 Display the Save menu.

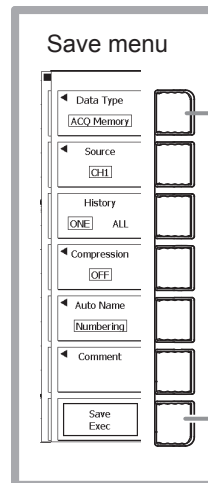

5 Set the type of data to be saved to ACQ Memory.

These settings not required by this operation guide, but you can enter them as needed.

6 Execute the save.

MEMO